

THE AMERICAN
GAS LIGHT JOURNAL.

(ILLUSTRATED.)

DEVOTED TO THE INTERESTS OF
ILLUMINATION, VENTILATION, WATER SUPPLY,

— AND —

GENERAL SCIENCE.

VOLUME XLVI.

(TWENTY-NINTH YEAR.)

FROM JANUARY 3d TO JUNE 16th, 1887.

A. M. CALLENDER & CO., Publishers.

OFFICE OF PUBLICATION, No. 42 PINE STREET, NEW YORK CITY

INDEX TO VOL. XLVI.

A.

Alho-Carbon Light Company Secures a Favorable Decision.	13
Amending the Constitution, American Association.	35
Armington, J. H., Some Suggestions on Paper Writing.	35
Annual Reviews.	74
Applications for and Election to Membership, New England Association.	131
Address of President Harrison, New England Association.	131
Associate Members, Proposition to Admit in New England Association.	173
Address of President McMillin, Ohio Association.	207
Address of President Fullagar, Western Association.	343

B.

Boardman, A. E., Suggestions upon Candle Power and Illumination.	7
Board of Trade Returns.	9
Big Bonfire.	10
Brookline Gas Company, Annual Meeting of the.	77
Busy Constructors.	130
Briefly Told.	170
Big Gas Bills Paid on Account of Household Consumption.	254
Bates, T. A., Condensation and the Elimination of Tar.	282
Butterworth, I., Regenerative Furnace Adapted to a Small Gas Works.	281

C.

Candle Power and Illumination, Suggestions upon, by A. E. Boardman.	7
Carpenter's Generator Furnaces.	10
Comparisons on Cost of Gas, Electric Light and Oil, by E. Stein.	35
Clark, Walton, An Experiment with Lined Coal.	34
Coke Stove, a Portable.	77
Curious Flames.	196
Curious Gas Flames, by T. Fletcher.	180
Combustion, Discussed by A. F. Upton.	181
Candle Power and Illumination, by C. F. Prichard.	139
Committee on President's Address, Report of, New England Association.	173
Coke; what Quantity is used to Carbonize 2,240 lbs. of coal?	174
Coal, a Substitute for.	185
Choked Stand-pipes: Is there a Remedy? by N. Klusman.	247
Converse, C. M., on Uniform vs. Special Rates for Gas.	247
Cast Iron Pipe, How to Select.	252
Condensation and Elimination of Tar, by T. A. Bates.	282
Coke, New Way of Utilizing.	286
Cast Iron Pipe, the Selection of, by J. H. Decker.	310
Coal and Water Gas, Relative Cost of, by G. H. Christian, Jr.	311
Christian, G. H., Jr., on Relative Cost of Coal and Water Gas	311
Coal Dust, Relation of to Mine Explosions.	316
*Coke Stove, the "Richelieu".	316
*Coglievina, D., on Influence of Length of Photometer Bar in Determining Results, etc.	317, 348
Central Falls, R. I., Light for.	350
Corporation, a Reckless.	350
Coal Tar, Applications for.	350
Committee on President's Address, Report of, Western Association.	376
Cincinnati (Ohio) Gas Light Company vs. Chas. J. Steinau.	381
Correspondence, Special English.	9, 73, 146, 217, 286, 349

CORRESPONDENCE—

"A. S." is not Convinced.	109
Cadiz, a Dissenting Opinion from.	220
Egner, F., in Reply to "A. S."	77
Egner, F., in Further Explanation of that "Chapter"	149
Letter from the President of the Port Hope (Ont.) Gas Company.	321
McMillin, E., Refers to F. Egner's "Chapter on Practical Gas Making"	13
Piping Rules in Force at Indianapolis, Ind.	257
Public Lighting in Brooklyn, N. Y.	289
Righteous Decision, a.	385
Wells, W. T., Gives Reasons for His Belief.	385

D.

"Daily News" Gives Advice to Gas Consumers.	10
Directors, Board of, Report to New England Association.	133
Decker, J. H., on How to Select Cast Iron Pipe.	310
Distillation of Coal, the, by J. Glimper.	376

E.

Electric Light, the, Gets Notorious.	10
Electric Light, Gas and Oil, Some Comparisons on Cost of, by E. Stein.	35
Electric Lighting, by C. F. Spaulding.	37
Earthquakes, T. Turner's Charleston Experience.	38
Egner, F., Supplement to the Chapter on Practical Gas Making 40; *An Improvement (not on paper only) in Apparatus for Making Gas 145; An American Gas Institute.	344
Election of Officers, New England Association.	138
Election of Officers, Ohio Association.	315
Election of New Members, Ohio Association.	207
Election of New Members, Western Association.	375
Experiments on Flame.	42
Electric Light and Gas Supply: Shall They be Combined? by Jos. R. Thomas.	67
Electric Lighting, Can a Gas Company Afford to Take it Up?	176
Executive Committee, Ohio Association, Report of.	207
Electric Piper Being Paid in Brooklyn, N. Y.	322
Electric Lighting in Worcester, Mass., Cost of.	322
*Electric Lighting, The Waterhouse System of.	380

EDITORIALS—

Astounding Proposition, an.	130
Brooklyn, N. Y., Varying Phases of the Lighting Question in.	97
Brother Littleton's Preliminary Appeals.	169
Concerning 1886, a Word or Two.	1
Chicago Gas Trust, the.	310
Discriminative Suit, the Baltimore, Md.	170
Editor Stone and the Gas Companies.	374
Feast Follows Famine.	93
Fish, H. H., Death of.	242
Fraternal Token from Across the Sea.	373
Commission, Is New York to Have one?	98
Gas Managers, Annual Meeting of the.	206
Ill's Capsule Memorandum.	309
Obituary.	278
Ohio's Commission, Annual Report of the.	98
Ohio's Commission, First Verdict Rendered.	342
of.	66
tion, Annual Meeting of the.	66
tion's Meeting, the.	130
Dayton Meeting of the.	206

EDITORIALS—Continued.

Programme of the Ohio Association.	170
Public Lighting in New York City.	242
Society of Gas Lighting, Annual Meeting of the.	33
Strecker, Mr. A., Surprised.	206
St. Louis Meeting, Almost Ready for the.	278
St. Louis Meeting, the.	309
Tihhals, H. H., Obituary Note.	2
Tin Wedding of the Western Association.	341
Water Gas Fuel, Should the Supply of be Permitted?.	65
Walker, Sr., Jas. H., Obituary.	241

F.

Flame, Experiments on.	42
Fire Kindling Device, an Ingenious Automatic.	73
*Fuel, Liquid, by L. T. Wright.	67
Foullis Gas Fire, the.	146
Flemming, D. D., Resignation of.	170
Fletcher, T., on Curious Gas Flames.	180
Fish, H. H., Death of.	242
Fullagar, J., Presidential Address.	343
Fuel Gas, in Regard to the Distribution of, in Troy, N. Y.	374

G.

*Gasholder Houses, New Departure in, by W. H. White.	4
Gas, Electric Light and Oil, Some Comparisons on Cost of, by E. Stein.	35
Gas Making, a Supplement to the Chapter on Practical, by F. Egner.	40
Gas Companies and the State.	42
Gas and Electric Lighting Supply: Shall They be Combined? by Jos. R. Thomas.	67
Gas as a Domestic Servant.	73
Gas Commission for the State of New York, Senator Worth's Bill to Establish.	103
Gas Machines, Rules and Regulations for the Use of.	104
*Gas Soldering Iron, the Economic.	105
Gas Business (England) During the Second Half of 1886.	147
Guild of Gas Managers Tenders Hospitality to New England Association.	131
Gas Mains Laid Across Stone Culverts, How Can They be Best Protected in Winter?.	174
Gas Burners, the Way in which to Introduce High Candle Power Sorts to Gas Consumers, by F. S. Richardson.	143
Gas Burner, the Velsbach Incandescent.	181
Gas Commissions, by M. A. Gemuender.	209
Gemuender, M. A., as above.	209
Gas and Electricity: Two Interests or One? by G. W. Graeff, Jr.	212
Graeff, G. W., Jr., as above.	212
Gas with Electricity, by Thos. Wood.	214
Gas Companies (English) Accounts for the Second Half of 1886.	217
Gas Supplied to Stoves, Engines, etc., Is it Good Policy for Companies to Sell such at a Reduced Rate? by W. W. Prichard.	248
Gas Works Damaged by Fire.	258
*Gas Burner Tips, Causes and Prevention of Stoppage in, by E. Printz.	280
Guide Framing for Gasholders, Is it Necessary that it Should be Lofty.	284
Gas Engineers, the Status of.	286
Gasholder Guide Framing, Novel Views about.	286
Gas Cooking Stoves, Pushing the Use of.	287
German Coal Trade, State of the.	322
Gas Institute, on a Proposed American, by F. Egner.	344
Gas for the People.	350
Gas Fittings, Rules for Testing.	374
Gimper, J., on the Distillation of Coal.	376
Gas from Lime Stone.	378

H.

Hints for Steam Users.	43
Humphrys, N. H., on the New Works of the South Metropolitan Gas Company, London, England.	102
Honorary Members Elected by New England Association.	133
Honorary Members Elected by Ohio Association.	207
Humphreys, C. J. R., Some Thoughts on Purification of Gas by Iron Oxide.	136
Harrison, J. P., Presidential Address.	131
High Candle Power Burners, the Introduction of, by F. S. Richardson.	143
*Hydrometer, Smale's Pneumatic.	146
Hefner-Alteneck Photometrical Standard.	146
High-Tension Circuits, Incandescent Lights on.	253
Hamlin, E. W., on Tar as an Enricher.	279

I.

Incandescent Lamp Causes the Destruction of a Phila., Pa., Theater.	70
Iron Oxide, Some Thoughts on Purification of Gas by, by C. J. R. Humphreys.	136
Illumination and Candle Power, by C. F. Prichard.	139
*Improvement in Apparatus for Making Gas, by F. Egner.	145
Incandescent Gas Burner, the Velsbach.	181
Incandescent Lights on High Tension Circuits.	253
Iron, New Process for the Protection of.	348
Items of Interest from Various Localities 10, 43, 74, 106, 147, 183, 218, 254, 257, 318, 351, 382	

K.

Klusman, N., on a Remedy for Choked Stand-pipes.	247
King, J. O., Obituary.	278

L.

Lined Coal, an Experiment with, by W. Clark.	34
Lecture on Natural Gas.	40
*Liquid Fuel, by L. T. Wright.	67
London Gas Companies, the.	147
Lined Coal for Gas Making, Dr. Knublauch's Experiments on.	217
Lightfoot Refrigerator and Otto Gas Engine.	252
Limestone, Gas from.	378

M.

Meter Connections, Proposing to Make Uniformity in.	40
Merrick, Wm., Death of.	66
Morton, H., President, on the Storage Battery.	98
Memorial Committee, New England Association, Report of.	179
Meters, Proving or Testing.	182
McMillin, E., Presidential Address.	207
Massachusetts Law for the Proposed Regulation of the Supply of Electric Light by Gas Companies.	251
Memorial Committee, Ohio Association, Report of.	315
McCurdy, O. C., Death of.	310
Memorial Committee, Western Association, Report of.	375
Market for Gas Securities, the.	14, 46, 78, 110, 150, 186, 221, 258, 290, 322, 354, 386

N.

Natural Gas, Lecture on.	40
Naphtha as an Enricher, by "A. S."	41
Norton, Hon. A. M., on Effects of Reduction in Price of Gas	133
Naphthalene, Treatment of, by E. G. Pratt.	138
Natural Gas in England.	350
Notes from the West, by Retort.	12, 106, 182

O.

Oil, Gas and Electric Light, Comparison on Cost of, by E. Stein.	35
Oxide of Iron, Some Thoughts on the Purification of Gas by, by C. J. R. Humphreys.	136
*Otto Gas Engine and Lightfoot Refrigerator.	252
Oil Gas in England.	286
Oil, the Action of on Metals.	382
OFFICIAL NOTICES, ETC.—	
New England Association.	1, 33, 65
Ohio Gas Light Association.	33, 97, 129
Western Gas Association.	129, 169, 205, 241, 277

OFFICIAL REPORTS—

American Gas Light Association, XIV. Annual Meeting of (concluded from Vol. XLV.).	2, 34
New England Association of Gas Engineers, XVII. Annual Meeting of.	131, 171
Ohio Gas Light Association, III. Annual Meeting of.	243, 279, 311
Western Gas Association, X. Annual Meeting of.	343, 375—Continued.

P.

Paper Writing, Some Suggestions on, by J. H. Armington.	35
Practical Gas Making, a Supplement to the Chapter on, by F. Egner.	40
Pittsburgh, Pa., as Seen by an Englishman.	71
*Pipe Wrench Converter Attachment.	105
Purification of Gas by Iron Oxide, Some Thoughts on, by C. J. R. Humphreys.	136
Pratt, E. G., on the Treatment of Naphthalene.	138
Photometry, Units of, by R. B. Taber.	140
Prichard, C. F., on Candle Power and Illumination.	139
*Pneumatic Hydrometer, Smale's.	146
Prichard, W. W., on the Policy for Selling Gas to Stoves and Engines at a Reduced Price.	248
Page, G. S., on Residual Products.	177
Personal, J. W. Bate.	258
*Printz, E., on Causes and Prevention of Stoppages in Burner Tips.	280
Pipe and Pipe Threads, Standard.	285
Pratt, E. G., Bidding Good-by to.	322
Paris Gas.	386
*Photometer Bar, Has the Length of any Influence in Determining the results of the Observations, by D. Coglievina, C.E.	317, 348
Process, a New, for the Protection of Iron.	348
Papers, How They are Hereafter to be Procured for Presentation to the Western Association.	379
Place for Next Annual Meeting, Naming, Ohio Association.	315

Q.

Question-box, American Association, 38; New England Association.	173
--	-----

R.

Rules and Regulations Relating to the Use of Gas Machines	104
Roll Call: New England Association, 131; Ohio Association, 207; Western Association.	343
Reduction in Price of Gas, the Effect of, by Hon. A. M. Norton.	133
Richardson, F. S., on the Introduction of High Candle Power Burners.	143
Removals.	278
Relation of Coal Dust to Mine Explosions.	316
*Richelieu Coke Stove, the.	316
Reorganized.	322
Rules for Testing Gas Fittings.	374

S.

Slater, A. B., on Three-Hour Charges.	2
Stein, E., on Comparisons on Cost of Gas, Electric Light and Oil.	35
Spaulding, C. F., on Electric Lighting.	37
State, the, and the Gas Companies.	42
Sulphate of Ammonia, How to Make an Analysis of.	72
Smokeless Fires.	73
Storage Battery, the, by Pres. H. Morton.	98
South Metropolitan Gas Company, New Works of, at East Greenwich, London, by N. H. Humphrys.	102
*Soldering Iron, the Economic Gas.	105
Secretary and Treasurer, Reports of—New England Association, 132; Ohio Association.	207
*Smale's Pneumatic Hydrometer.	146
Strecker, Mr. A. S., Surprised.	206
Sulphate of Ammonia as a Manure.	217
Special vs. Uniform Rates for Gas, by C. M. Converse.	247
Selling Gas for Stoves, Engines, etc., at a Reduced Price, on the Policy of, by W. W. Prichard.	248
Suit for Damages.	278
Sulphate of Ammonia, Manufacture of from Waste Furnace Gases.	288
*Stoppages in Burner Tips, Causes and Prevention of, by Eugene Printz.	280
Standard Pipe and Pipe Threads.	285
Stealing Street Lamps.	322
Steam Roller Case.	349
Sulphate, How to Sell it.	350
Siberian Exhibition.	350
Steinau, C. J., the Cincinnati Gas Light Company against.	381

T.

Tibbals, H. H., Obituary Note.	2
Three-Hour Charges, by A. B. Slater.	2
Tar, How Can the Demand for it be Increased?.	38
Turner, Thos., on His Charleston Earthquake Experience.	38
Thomas, J. R., on Gas and Electric Lighting Supply: Shall They be Combined?.	67
Taber, R. B., on Units of Photometry.	140
Temperature and Consumption of Gas.	146
Testing or Proving Meters.	182
Tar as an Enricher, by E. W. Hamlin.	279

U.

Useful Hints for Steam Users.	43
Units of Photometry, by R. B. Taber.	140
Upton, A. F., Discusses Combustion.	181

V.

Votes of Thanks, American Association, 46; New England Association, 178; Ohio Association.	315
Velsbach Incandescent Gas Burner.	181

W.

*White, W. H., on a New Departure in Gasholder Houses.	4
*Wright, L. T., on Liquid Fuel.	67
Worth's (Senator J.) Bill to Create a Gas Commission for the State of New York.	103
Wood, T., on Gas with Electricity.	214
Walker, J. H., Sr., Obituary.	241
Worcester, Mass., Cost of Public Electric Lighting in.	322
*Waterhouse System of Electric Lighting.	380

Y.

Young's Ammonia Purification Process.	74
---------------------------------------	----

THE AMERICAN
GAS LIGHT JOURNAL.

(ILLUSTRATED.)

DEVOTED TO THE INTERESTS OF
ILLUMINATION, VENTILATION, WATER SUPPLY,
— AND —
GENERAL SCIENCE.

VOLUME XLVII.

(TWENTY-NINTH YEAR.)

FROM JULY 2 TO DECEMBER 16, 1887.

A. M. CALLENDER & CO., Publishers.

OFFICE OF PUBLICATION, No. 42 PINE STREET, NEW YORK CITY

INDEX TO VOL. XLVII.

A.	E.—Continued.	I.—Continued.	P.—Continued.
American Gas Institute, Report of Special Committee, Western Association 6	Engines for Driving Dynamos, Regulating L.C. Speed of 141	Illuminating Power of Coal Gas, Effect of Carbonic Acid upon the, by J. T. Sheard 227	Printing the Papers in Advance, American Association 327
Amending the By-Laws, Western Association 39	English Gas Companies and Mineral Oil 199	Irish Bog Oxide of Iron, on the Determination of Hydrous and Anhydrous Peroxide of Iron in 332	Publishing the Proceedings, American Association 328
Ammoniacal Liquor as a Manure 73	Electric Lighting from Central Stations 231	Intensity of Light and Visual Perception, the Relation of, by Ed. C. Jones 275	Purification Puzzles, by Thos. Turner 321
Artesian and Gas Wells 74	Electricity, Gas into 257	Intensity of Light and Visual Perception, the Relation of, by Ed. C. Jones 275	Page, G. S., on the Market for Residual Products 383
Accident, a Remarkable 137	Executive Committee, Report of, American Association 264	*Illumination vs. Candle Power, by A. C. Humphreys 272	Petrolem Fields of India 333
Antiseptics, the Use of in Preserving Railroad Ties and Timber 166	Executive Committee, Supplementary Report from, American Association 327	Intensity of Light and Visual Perception, the Relation of, by Ed. C. Jones 275	Purification <i>in situ</i> 361
Alternating Currents, Distributing by 169	Electric Light Business, the Advantages to Gas Companies of Engaging in, by E. J. King 317	Illuminating Power of Gas, Comparative, when Purified with Lime or Oxide of Iron by C. W. Blodget 320	Plainfield (N. J.) Public Lighting 386
*Alvoine's Plan of Hydraulic Mains Used in the Dijon Gas Works 233	Energy, the Conservation of 357	Indian Petroleum Fields 333	Q.
Advice to Gas Consumers 229	EDITORIALS—	Items of Interest from Various Localities 10, 43, 74, 106, 138, 170, 202, 234, 250, 307, 362, 394	Question-Box, Western Association 2, 66
Association of Gas Managers, the North of Ireland 259	American Association, the Coming Meeting of the 162		R.
Amending Art. IV. of Constitution, American Association 265	American Gas Institute, in Regard to the Proposed 33	J.	*Rule of the Inverse Squares, by B. E. Chollar 7
Address of President Greenough, American Association 236	"Baby Process," a Sample of Gas Made by the 34	Jottings from Rome, Italy, by E. Schinrock 36	Rome, Italy, Jottings from, by E. Schinrock 36
B.	Books Received 306	Jones, C. E., on Gas Coke as a General Fuel 101	Regulating the Storage of Inflammable Substances, Dist. of Columbia 41
Breeze and Coke as Boiler Fuels 187	Chicago Gas Situation, perplexities in the 225	Jones, Ed. C., on the Relation of Intensity of Light and Visual Perception 275	Russia, Coke in 78
Blythe, T., Regenerative Retort Firing System for Small Gas Works 168	Corporate Luck, The American Gas Improvement Company 130	Kokomo (Ind.) Gas Well 46	refrigerating apparatus, Tests of 104
Bindings of Books, Effect of Gas on the 259	Correspondence, a Self-Explanatory 353	King, E. J., on the Advantages of Gas Companies Engaging in the Electric Light Business 317	*Richard Brothers' Standard Gas Gauges 106
Baltimore Gas War, End of the 284	Dayton Ohio City Council, Decision of the 129	Lungren Burner, the, by T. A. Cosgrove 63	Remarkable Accident 137
*Blodget, C. W., on the Comparative Illuminating Power of Gas Purified with Lime vs. Oxide of Iron 320	Tennison, W. H., Personal Mention of European Gas Association Meetings, the Exeter Theater Disaster 194	Leakage from Gas Mains, Detection of 73	Regulating the Speed of Engines for Driving Dynamos 141
Bredel, F., on the Advantages of Regenerative Furnaces for Large and Small Gas Works 324	Fuel Gas Question 385	Lighting Strokes, How to Protect Tall Chimneys from 78	Railroad Ties and Timber, the Preservation of by Antiseptics 166
British Columbia, the Gas Works of 386	Gas Institute, Progress in the Matter of the Proposed 98	Levey's Electric Light Primer 98	Regenerativ Retort Firing System for Small Gas Works, by T. Blythe 168
C.	Harrison, F. E.—Obituary 2	Lectures on Coal Gas, by Lewis T. Wright 137	Russian Petroleum 229
*Chollar, B. E., on the Rule of the Inverse Squares; Candle Power and Castigation 354	Levy's Electric Light Primer 98	Lunge, on "Coal Tar and Ammonia," a New Edition of 301	Roll call, American Association 263
Cement from Blast Furnace Slag 13	New York Meeting, the American Association's 257	Leavenworth, Gen. E. W., Death of 366	Residual Products, Utilization of, by C. H. Nettleton 279
Cosgrove, T. A., on the Lungren Burner 68	Nettleton and King Papers, the 305	Lighting Test at the Grand Central Railway Depot, Cincinnati, Ohio, Results of the 392	Regenerative Furnace, Development of the Half-Depth, and Some of the Results, by O. Weber 324
Committee on Place of Meeting, Western Association, Report of 38	Not Quite so Ghtering 285	M.	Regenerative Furnaces, the Advantages of for Large and Small Gas Works, by F. Bredel 324
Coal Tar, Uses for 66	Putnam, C. E.—Obituary Note 162	Men in the Retort House, Considering the Policy of Working Three Shifts of in 24 Hours 73	*Regenerator Tar Furnace, by J. Somerville 387
Committee of Arrangements, Western Association 73	Progress Scored in 1887 1	Mains, Gas, Detection of Leakage from 73	Railroad Cars, How Shall They be Heated? 391
Coke Market, the English 73	Springfield, Mass., the Outcome at 65	Manufacture of Coal Gas, an Abstract of Four Lectures, by Lewis T. Wright 195	Results of the Lighting Test at the Grand Central Railway Depot, Cincinnati, Ohio 392
Crosotied Brick for Street Pavements 74	Warning, the Final in Regard to the American Association Meeting 226	Mineral Oil and the English Gas Companies 199	S.
Chimneys, How to Protect Tall from Lightning Strokes 78	Welcome Home to Mr. E. Stein 194	Motive Power, Compressed Air as a 203	Spectroscopical Test of Tar Colors 8
Coke in Russia 78	F.	Marsault's Coal Washer 205	Slag, Cement from Blast Furnace 13
*Coke, a Paper by Chas. Gandon 99	Furnishing Gas without a Holder, by J. W. Dunbar 37	*Machine for Piercing Gas Pipes, a Handy 232	Spencer, R., Letter from to Western Association 39
*Coke as a General Fuel, by C. E. Jones 101	Forbes, G., on Electric Lighting from Central Stations 231	Mortou, H., President Takes Part in the Discussion on the Humphreys' and Jones' Papers, American Association 276	Schinrock, E., Jottings from Rome, Italy 38
Coke and Breeze as Boiler Fuels 137	Fuel Gas Plant in Pittsburgh, Pa. 110	Municipal Gas Works, Shall Chicago Have a? 306	*Screwing and Tube Cutting Machine 41
Coal Oil Lamps, Dr. Flock's Experiments on Coal Gas, the Manufacture of, an Abstract of Four Lectures by Lewis T. Wright 195	Flock's (Dr.) Experiments on Coal Oil Lamps Furnaces, Generator, for Small Gas Works 141	McMillin, E., on Fuel Gas 311	Suez Canal, the Electric Light at the 41
Coal Washers, the Marsault 205	Finance Committee, Report of, American Association 266	Meter Connections, Reports of Special Committees, American Association, on a Uniform Standard of 266, 317	Societe Technique de l'Industrie du Gaz en France 74
Carbonic Acid, Effect of upon the Illuminating Power of Coal Gas, by Jno. T. Sheard 227	Fuel Gas, by Emerson McMillin 311	Monks, R. J., on Disadvantages Occasioned by Fluctuations in Candle Power of Gas Supplied to Consumers 323	Sulphate of Ammonia, Production of in England 74
Carbonic Acid, Effect of on the Illuminating Power of Coal Gas, by C. W. Hinman 258	Furnace, Half-Depth Regenerative, Development of, by Oscar Weber 324	Mortar, the Effects of Freezing on Cement 390	*Standard Gas Gauges, Richard Brothers' 106
Coal Gas Basis, A 259	Furnaces, Regenerative, Advantages of for Large and Small Gas Works, by F. Bredel 325	Market for Gas Securities, the 14, 45, 78, 110, 142, 174, 206, 238, 285, 334, 366, 398	Short Belts for Driving Dynamos 109
Claus' Process of Purification 259	Fog, the Cost of a Day's to Londoners 386	N.	Speed of Engines for Driving Dynamos, Regulating the 141
Coke Scrubbers, New Filling for 259	G.	Natural Gas, How to Enrich 69	*Standard Ammeter, the Waterhouse 199
Constitution, Draft of a New, as Recommended by Executive Committee of American Association 274	Gas Institute, Meeting of the 9	Nettleton, C. H., on the Utilization of Residual Products 279	Sheard, J. T., on the Effect of Carbonic Acid, etc. 227
Clark, Walton, on Water Gas 269	Gas for Cooking and Heating 9	Noble, A., on the Effects of Freezing on Cement Mortar 390	Sutherland, J., on the Determination of Certain Ingredients of Irish Bog Oxide of Iron 232
Committee on President's Address, American Association, Report of 269	Gas Furnished without a Holder, by J. W. Dunbar 37	Notes from the West, by Ketort 10, 42, 110, 130, 365	Secretary and Treasurer, Annual Report, American Association 263
Complaints 285	Gasholders, What Causes the Formation of Small Holes in the Iron of 68	O.	Special Committees, Appointment of, American Association 269
Chicago (Ills.), Shall it Have a Municipal Gas Works? 306	Gas and Artesian Wells 74	Oil Gas, a Glance at Some Past Projects for the Manufacture of, by N. H. Humphreys 39	Stemm, the Use and Value of Coke for Generating, by J. L. Hallett 326
Committee of Arrangements, '88 Meeting of American Association 350	Gas Institute, British, Papers Read at the Recent Meeting of 97, 101, 131	Oxide of Iron, Purification of <i>in situ</i> 73	Spice, R. P., on the English Gas Business 327
Candle Power of Gas, Disadvantages of Fluctuations in that Supplied to Consumers, by R. J. Monks 323	*Gaudou, Chas., on Coke 99	Ohren, M., and the Sulphur Compounds 137	Saccharin 332
Coke, the Use and Value of for Generating Steam, by J. L. Hallett 326	*Gas Gauges, Richard Brothers' Standard 103	Oil Lamps, Dr. Flock's Experiments on 138	Soldering, Difficult 332
Committee of Investigation, Appointment of, American Association 327	*Gasholders, the Guide Framing of, by W. H. Y. Webber 131	Oil and Water Gas as Illuminants, by C. F. Prichard 226	*Shadowless Arc Light Pole, the Crompton 334
Combustion 353	Gas Light and Coke Company, the Accounts of the 138	Oxide of Iron vs. Lime, Comparative Illuminating Power of Gas Purified by, C. W. Blodget 320	*Structural Capacity and Cost of Gas Works, by V. Wyatt 355
*Crompton's Shadowless Arc Light Pole 334	Generator Furnaces for Small Gas Works 141	Oxide of Iron, Valuation of in the Purification of Gas 331	Somerville, J., on a Regenerator Tar Furnace 387
Candle Power and Castigation 354	Gas Managers, Hints to 174	OFFICIAL NOTICES, ETC.—	T.
Cheap Gas in England 361	Gas Companies (English) and Mineral Oil 199	American Gas Light Association 97, 161, 193, 225	Tar Colors, Spectroscopical Test of 8
Cement Mortar, the Effects of Freezing on, by A. Noble 290	Gas and the Stage 201	OFFICIAL REPORTS—	*Tube Cutting and Screwing Machine 41
Cincinnati (Ohio), Results of the Lighting Test at the Grand Central Railway Depot 392	*Gas Piping, a Handy Machine for Piercing Gas into Electricity 232	American Gas Light Association, XV. Annual Meeting of 263, 311	Timber and Railroad Ties, Preservation of by Antiseptics 166
Conservation of Energy 397	Gas, the Effect of on the Binding of Books Gas Companies and the Electric Light, Advantages to of Engaging in, by E. J. King 317	Western Gas Association, X. Annual Meeting of (Concluded from Vol. XLVI.) 2, 34, 66	Told Briefly—Proposed Extension to the Washington (D. C.) Company's Plant 205
Correspondence, Special English 9, 73, 137, 200, 259, 361	Gas, Candle Power of, the Disadvantages of Fluctuations in that Supplied to Consumers, by R. J. Monks 223	P.	Trenching and Pipe Laying 306
CORRESPONDENCE—	Generating Steam, the Use and Value of Coke for, by J. L. Hallett 326	Plants and the Electric Light 2	Turner, Thos., on Three Purification Puzzles 321
Flow from a Natural Gas Well, How Should it be Determined? 77	Gas Interest in England, Mr. R. P. Spice on the 327	Purification of Oxide of Iron <i>in situ</i> 73	Turning the Tables—the Results of an Expert Meter Tester's Work in Cincinnati, O. 360
Information on Leakage Percentages Allowable, Seeking for 77	*Gas Works, Structural Capacity and Cost of, by V. Wyatt 355	Papers Read at the Meeting of British Gas Institute 99, 101, 131	Tar Useless for Gas Making 362
Meters, State of, a Simple Plan for Showing to Consumers 305	Gas for the Million 362	Pyro-Magnetic Dynamo, Summary of a Paper, by T. A. Edison 136	*Tar Furnace, a Regenerator, by J. Somerville 387
Tar Pavements, How to Make 257	Gas Works of British Columbia 386	Pittsburgh, Pa., Fuel Gas Plant in 110	Tar from Gas, Utilization of 392
D.	*Gas Tar, Utilization of 392	Painting Ironwork 142	U.
Dunbar, J. W., on Furnishing Gas without a Holder 37	Grand Central Railway Depot (Cincinnati, Ohio) Results of the Lighting Test at 392	Patnam, Cbas. E., Obituary Note 162	*Utilization of Gas Tar 392
District of Columbia, Regulating the Storage of Inflammable Substances in 41	H.	Purification in Closed Vessels, by Wm. Young 163	V.
*Damper Frame for Furnaces, Humphreys' Patent 105	Humphreys, N. H., on Some Past Projects for the Manufacture of Oil Gas 29	Preservation of Railroad Ties and Timber by the Use of Antiseptics by J. P. Card 166	Votes of Thanks, Western Association, 73; American Association 330
Dynamos Driven with Short Belts 105	Honorary Members, Election of, Western Association 58	Peroxide of Iron in Irish Bog Ore, on the Determination of 232	Visual Perception, the Relation of Intensity of Light and, by Ed. C. Jones 275
Dynamo, the Pyro-Magnetic, Summary of a Paper, by T. A. Edison 136	*Humphreys' Patent Damper Frame for Furnaces 105	Place for Next Meeting, Western Association 38	Vote of Sympathy by American Association to J. R. Thomas 331
Dynamos, Regulating the Speed of Engines for Driving 141	*Hydraulic Main, the Alvoine Plan of as Used in the Dijon Gas Works 233	Place for Next Meeting, American Association 282	Valuation of Oxide of Iron for the Purification of Gas, by H. L. Greville 331
Distribute on by Alternating Currents 169	Hinman, C. W., on the Effect of Carbonic Acid on the Illuminating Power of Coal Gas 258	Power, Compressed Air as a Motive 200	W.
Ditdin, W. J., on Photometrical Standards 200	*Humphreys, A. C., on *Illumination vs. Candle Power 272	Photometrical Standards, W. J. Ditdin on 200	Watts, S., Resolution Offered in Regard to the Eguer Institute Proposition, Western Association 6
Dangers of Oil Lamps 232	Half-Depth Regenerative Furnace, etc., by O. Weber 324	Petroleum Scare, an English 201	Wells, Artesian and Gas 74
Difficult Soldering 332	Hallett, J. L., on the Use and Value of Coke for Generating Steam 326	Prichard, C. F., on Oil and Water Gas as Illuminants 226	*Webber, W. H. Y., on the Guide Framing of Gasholders 131
Distillation of Wood 333	I.	Prichard, C. F., on Oil and Water Gas as Illuminants 226	Western Affairs, by Diaphragm 173, 238
E.	*Inverse Squares, the Rule of the, by B. E. Chollar 7	Petroleum in Russia 229	Wright, Lewis T., Abstract of Four Lectures on the Manufacture of Coal Gas 195
Electric Light and Plants 2	Inflammable Substances, Regulating the Storage of in Washington, D. C. 41	*Piercing Gas Pipes, a Handy Machine for President's Address, Report of Committee on, American Association 283	*Waterhouse Standard Ammeter 199
Electric Light, What is the Best Way to Fight It? 2	Institute, the British Gas, Some of the Papers Read at Last Meeting of 99, 101, 142	Z.	Washer, Marsault's Coal 25
Electric Light and Plant Life 9	Ironwork, Painting 142	Zirconia, Valuable Deposits of 262	Water and Oil Gas as Illuminants, by C. F. Prichard 226
English Gas Exhibitions, at the 9	Illuminants, Oil and Water Gas as, by C. F. Prichard 226		Wheeling, West Va., How Gas Works Officials are Selected at 261
Election of Officers, Western Association 57			Water Gas, by Walton Clark 269
Election of Officers, American Association 284			Weber, O. B., on Development of the Half-Depth Regenerative Furnace, and Some of the Results 324
Election of Hourary Members, Western Association 39			Wood, Distillation of 333
Election of New Members, American Association 266			
the Suez Canal 41			
iation, Meetings of the 66			
ary of a Paper by, ou a 136			

64505
A M
v. 46-47

Chem

REMOTE STORAGE

THE AMERICAN

GAS LIGHT JOURNAL

REDMAN KEENE, N. Y.

PUBLISHING OFFICE NO. 42 PINE STREET

DEVOTED TO THE INTERESTS OF ILLUMINATION, VENTILATION, WATER SUPPLY AND DISTRIBUTION, & GENERAL SCIENCE.

VOLUME XLVI.—No. 1.
Whole No. 661.

NEW YORK, MONDAY, JANUARY 3, 1887.

{ \$3 PER ANNUM,
IN ADVANCE.

A. M. CALLENDER & CO., Proprietors. C. E. SANDERSON, Manager.
JOS. R. THOMAS, C.E., Editor. T. J. CUNNINGHAM, Asst. Editor.

ENTERED AT THE POST OFFICE AT NEW YORK, N. Y.
AS SECOND CLASS MATTER.

Published on the 2d and 16th of each month, at No. 42 Pine Street, N. Y.
Terms of Subscription, Including Postage.—For the United States and
Canada, \$3 per annum. European countries, \$3.50 (15 shillings—18 francs).
All payments to be made in advance. Single copies, 15 cents.

any member who has during the past year effected a saving in the produc-
tion or distribution of his gas will write out in detail what he has done, and
how he did it, and bring the statement with him to the meeting. Also, any
paper on any subject relative to gas or gas manufacture will be welcomed.
CHARLES H. NETTLETON, Sec'y.

CONTENTS.

An Asterisk (*) denotes an illustrated article.

OFFICIAL NOTICE—	
Annual Meeting of the New England Association.....	1
EDITORIALS—	
A Word or Two Concerning 1886.....	1
Obituary Note—Henry H. Tibbals.....	2
Fourteenth Annual Meeting of the American Gas Light Association	
—Official Report—Continued from Vol. XLV., page 363.....	2
Second Day, Afternoon Session—Three-Hour Charges, by A. B. Slater—Dis- cussion—*A New Departure in Gasholder Houses, by Capt. W. H. White— Discussion—Suggestions Upon Candle Power and Illumination, by A. E. Boardman—Discussion.	
Special English Correspondence.....	9
The Board of Trade Returns—The Daily News Gives Advice to Gas Consum- ers—The Electric Light Gets Notorious—Mr. C. C. Carpenter's Generator Fur- naces—A Big Bonfire.	
ITEMS OF INTEREST FROM VARIOUS LOCALITIES.....	
Colonel Fred. S. Benson to Take a Trip to Europe—One Day's Sendout from the Philadelphia Gas Works—Batavia (Ohio) Would Like a Gas Works— Named as Superintendent—A Word or Two from Geneva, N. Y.—A Sample of English Gas Rates—At Rest—Breckenridge Cannel Goes to Europe—To Pipe Natural Gas to St. Louis, Mo.—A Resolution with an "If"—A Letter from a Washington Territory Gas Man—Gas for Christmas Day—Gas Compe- tition at Findlay, Ohio—Gas for the Street Lamps of Kankakee, Ills.—The Cincinnati Gas Ordinance Passed—Public Lighting at Burlington, Iowa—The Edison Company, of Aurora, Ills.—A Gas Company's Water Bill—A Company that Proposes to Have Many Irons in the Fire—More Sport for Chicago, Ills.— Socorro, New Mexico, Wants a Gas Company—New Gas Coal Company— Election of Officers—Aurora (Ills.) Has an Electric Lighting Plant—A Sad Blow.	
Notes from the West, by Retort.....	12
In Favor of Plaintiff.....	13
CORRESPONDENCE—	
Mr. Emerson McMillin Refers to Mr. F. Egner's "Chapter on Practical Gas Making.".....	13
The Market for Gas Securities.....	14

A WORD OR TWO CONCERNING 1886.

The year 1886 having been properly and according to most modern usage
accredited to its niche in the collection of twelvemonths that preceded it, we
may be excused, while some of its more salient features come crowding fast
out of the mist that will so soon blot out the clear cut lines of even its most
radical happenings, for granting these relics of the past a brief moment of
resuscitation. If we do so it will be simply in hope that such rekindling
may enable us—even if ever so slight success attend the attempt—to peer
into the future, there to discover what 1887 contains for the gas men. In the
first place, the experience of '86 all goes to show and prove that the past
twelvemonth was one of almost unexampled expansion in the business of gas
supply. We have at least two score of letters recently received in reply to
as many queries made by us to men in different sections of the country, in
regard to how the sendout averages of last year compared with those of its
predecessor; and these responses, we are happy to say, are couched in one
tone. They show, in fact, surprising results; and while we are not at lib-
erty to furnish a key that would reveal individual situations, we may without
any violation of confidence, state that in 41 different places in the United
States—in none of them did the sendout exceed an annual total of 60 mil-
lions cubic feet, for we wished to estimate the rapidity or tone of the average
circulation by applying the test to the pulse of the lesser gas bodies—the
grand average percentage of increase shown figures out a trifle in excess of
26. There are many ways in which this gain may be accounted for; but
above all the other reasons stands this one—the fact that the policy of cheap-
ening sales rates has been steadily adhered to. Then, again, that policy has
been made doubly effectual by the business-like practice of keeping the man-
ufacturing and distributing plant in good working shape, which means that
"skimping" once thrown aside will never again be resorted to—skimping,
of course, being understood to mean the old-time idea that a superintendent
was expected to get along with two benches of fives when three benches of
sixes would hardly satisfy the requirements of the situation, or that he must
perforce be content with a gasholder the dimensions of which would hardly
be sufficient to recommend it to the favorable notice of a cook in case the
latter were in quest of a goodly-sized pot. We have at the moment in mind a
certain coal gas company whose proprietors, in 1884, were working along
under the skimping process; but, the spirit having seized them, during the
summer of the following year, they spent something less than \$20,000 in plant
betterment, etc. The leaven further worked to the extent that a liberal con-
cession in gas rates was next granted, and in 1886 the owners divided a
handsome cash dividend out of the earnings of the twelvemonth—the first
dividend that had been earned on gas shares in that locality for six years.

[OFFICIAL NOTICE.]

Annual Meeting of the New England Association.

To the Members of the New England Association of Gas Engineers:—The
Annual Meeting of this Association will be held in Boston, on February 16
and 17, 1887. The place where the meeting will be held will be announced,
together with the detailed arrangements, in the next issue of the JOURNAL.
It is hoped that a large number of the members will be present, and only
those will be absent who are detained by causes beyond their control.
There probably has never been a time when there was more necessity for
these meetings of gas managers than the present. The demand for cheaper
light, which is so universal, and the low prices at which many companies are
selling their gas, renders the utmost economy imperative; and these meet-
ings, with their papers and discussions, and the opportunities of interviews
between the members, furnish the easiest and best means of obtaining the
information necessary to produce this economy. The Secretary hopes that

One of the other notable features of the year has been the great decrease
in the matter of opposition gas ventures. Perhaps the rebuffs which
Equitable operators met with in Newark, N. J., and in Syracuse,
have made investors in this particular line more wary, and
of the ground floor owners in the Consumers Company
with the lack of substantial pecuniary recompense.

of the Chesapeake Company's Baltimore (Md.) scheme had the salutary effect of causing Mr. Speculator to keep a tighter hold on his money bags; but we still incline to the view that, after all, cheap gas and a plentiful supply of it are yet to have the lion's share of the credit. Certainly, those factors kept the would-be benefactors out of Brother Wood's Syracuse district, and a like state of affairs, aided by a well-drawn contract, accounts also for the Newark opposition fiasco. There can be no doubt any longer that the gas fraternity of the United States have about made up their minds to embark in the electric lighting business on joint account with gas supply, and there can be no possible ground for not believing that many of those who sanction the plan are eminently well qualified to pass a dispassionate, just, and logical verdict in the premises. Summed up in a few words, these base their opinion on the fact that electric lighting has come with us to stay, and, being with us as a permanency, the gas man can supply it more efficiently, and at the same time cheaper, than can be done by those who would seek to control it as an independent, or rather, distinct, branch of commercial and domestic service. This, then, can be set down as one of the revolutions effected in the sentiment of the artificial lighting business during 1886. It, however, is a revolution that carries no terror in its train, for the fortress is already in the hands of the gas men. In fact the new recruit, raw though he be, will no doubt prove a handy and valuable acquisition to the garrison. It might also be added that '86 witnessed the erection of many new gas plants to operate in districts hitherto outside the pale of the gas man's domain, and although the exact number of additions cannot be here given, certainly not less than a baker's dozen can be counted up. In the matter of technical advance no great victory was scored during the twelvemonth, although it can be said that the outlinings of the past year enable us to predict that the advocates of regenerative firing will witness great activity in that sort of construction in this country with the current year. Death had not made many gaps in the ranks of the fraternity in the twelvemonth just ended, the most shining marks perhaps being found in the persons of the late Messrs. Brewer, of Massachusetts; Taylor, of Ohio; Munzinger, of Pennsylvania; and Tibbals, of New York. Missed and mourned are those who have been taken from us; but in the wild rush of the active business man of our nineteenth century sentiment hardly finds strength to stay the pace. Our Associations have progressed and prospered, and bid fair to outstrip the promises of the most enthusiastic of their founders.

So, then, having hastily glanced backward, the retrospection bids us look onward hopefully and contentedly to the months of '87. In fact we may even predict, great as was the success of '86, that that of its successor will be even greater. With the heartiest of good wishes, and our sincere thanks, too, to those who honored us with their confidence in '86, we hope to make the JOURNAL still more acceptable to them in the future. Without an axe to grind on their own behalf, it is the aim of its owners to fairly reflect those sentiments connected with our common calling that are best calculated to place that calling on the firmest sort of footing.

OBITUARY NOTE.—HENRY H. TIBBALS.

No doubt many other members of the gas fraternity of the United States have obtained greater nominal prominence in the profession than did the one whose name heads this brief obituary note; but we may honestly assert that none other bore himself with greater manhood, nor with exceeding rectitude. Straightforward and steadfast in his somewhat uneventful career—so far as change of position and eccentricity of orbit are concerned—death has nevertheless created, through the taking off of Mr. Tibbals, a void in the hearts of those whom he served so faithfully and well that even years will not obliterate. Deceased had suffered with patience for many weary months, and welcomed at last the approach of the scythe-bearer, of whom it has been written, "He destroys but to save." Relief came on the morning of December 15, and the end of his journey may be likened to the even pace that marked his travel through life. Mr. Tibbals was born at Durham, Conn., on October 3, 1829, and the fall of 1853 found him in the service of Messrs. H. Esler & Co., proprietors of the Atlantic Dock Iron Works, whose shops were located near the Atlantic Basin, in South Brooklyn, N. Y. Deceased acted for the Messrs. Esler in a financial capacity, and was greatly esteemed by his employers. In 1862 Mr. Tibbals cast his fortunes with those of Mr. Thos. F. Rowland, Proprietor of the Continental Iron Works, at Greenpoint, N. Y., in whose service he remained to the end. We have used the word "Service," but the relations that ever existed between the deceased and Mr. Rowland make it but poorly expressive of those that were maintained between them. Deceased was a director in the Mechanics and Traders Bank, Greenpoint, and for years had served as vestryman of the Church of the Holy Trinity. His remains were removed, on date of December 18th, to New York for interment. Having lived an upright life, he leaves that sullied name—which, when recalled by the flash of the golden coin, grow brighter with the lapse of time.

[OFFICIAL REPORT.—Continued from Vol. XLV., page 363.]

Fourteenth Annual Meeting of the American Gas Light Association.

HELD AT THE ACADEMY OF MUSIC, PHILA., PA., OCT. 20, 21, AND 22, 1886.

SECOND DAY—THURSDAY, OCT. 21—AFTERNOON SESSION.

The final business session of the Association was called for 2 P.M. of October 22. At that hour the President introduced Mr. A. B. Slater, of Providence, R. I., who read the following paper on the subject of—

THREE-HOUR CHARGES.

There can, I think, be very little doubt in the mind of any member of this Association that whatever measure of success attends our meeting is largely due to the indefatigable efforts of our modest but energetic Secretary. In his zeal to work up and prepare subject-matter for consideration and discussion at our present annual gathering he forwarded to me a sort of mandatory order to write a paper upon "Three-Hour Charges." Knowing he was very well aware that in June, 1885, I read before the Society of Gas Lighting, at New Haven, Conn., a paper upon the same subject, and thus subjected myself to the subsequent criticism of such distinguished critics as the respective editors of the *London Journal of Gas Lighting* and the *Journal des Usines a Gaz*, I am rather at a loss to divine his motive. Whether he thinks there may be something worthy of thought and examination in such a departure from the old and long beaten track, or whether he wishes to set me up as a target to be shot at by the "old guard," I cannot decide; but, as our friend Pratt, of Jamaica Plain, Mass., said at the Pittsburgh meeting, "I am not thin skinned," and have endeavored to obey orders.

While I do not expect to say anything new upon the subject, the paper may perhaps open the way for discussion which will tend to convince some of the members that it is better for them to continue their system of four or five-hour charges, while it also may possibly lead others to investigation and experiment—where the necessary conditions can be reached—by keeping them in mind of the fact that if it is possible to run three-hour charges successfully and advantageously in one works it is certainly possible to do so in others.

I take it for granted that there are few, if any, of the members of this Association who have not outgrown the antique system of six-hour charges, notwithstanding the fact that after their long experience, coupled with their acknowledged ability, our English friends still adhere to the six-hour schedule in burning off a charge of coal. Without doubt they have their reasons for continuing that practice. It sometimes may be the case, in our zealous efforts to improve, that we in reality progress backward; still I believe it is true that Americans as a rule, whether engaged in the gas business or in any other commercial enterprise, have been steadily successful in their efforts for improvement; and if we investigate any line of business to-day we will find that few continue wholly in the use of ways and methods which were in vogue ten (or even five) years ago. One of our most conservative and valued instructors, when desiring to impress upon the minds of his pupils the fact that it is well not to go too fast, nor yet too slow, but to try and be able to distinguish between the visionary and the real, would quote the old adage, "Be not the first new things to try, nor yet the last to lay the old aside."

"The convenient duration of charges," said our London critic, "is one upon which every experienced manager has his mind fully made up." Were that remark applicable to the managers of this country, then the reading of this paper, and any discussion on the subject by the members of our Association, would be time wasted. But our experience leads us to hope that such will not be the case.

The first successful departure in this country from the old furnace—and which, as a generator furnace, produced conditions that made possible the carbonization of a fair quantity of coal in three hours—was effected in 1878 by Mr. Charles F. Dieterich, the accomplished Engineer of the then Peoples Gas Works of Baltimore, Md. His retorts were small—being 12 in. by 20 in. and 8 ft. in length—yet he carbonized 1,250 pounds of coal per bench every three hours as well as it is usual to see when the coal is allowed to remain in the retorts for four hours. It is a common notion that in order to properly work off a charge of coal in three hours an excessively high heat is necessary; but that is erroneous. Trouble is more likely to come when the heat is high and the small charges allowed to remain in the retort too long. In any system of furnaces, or combination of furnace, retorts, and settings, it is important that judgment be used in charging the proper quantity of coal according to the degree of heat maintained in the retorts.

Under the old method of working, when a charge of coal is introduced into a retort the heat is at once reduced, being absorbed by the vapor distilled from the coal, a large portion of which is not converted into gas, but carried on to the tar well. The conditions constantly change, according to the degree or quantity of heat which is generated, or until, after a short time, a sufficient temperature is developed to break up or convert more of

the vapors; and if one bench were running, and the retorts were all charged at once, we would find under ordinary circumstances that the larger portion of the gas came over during the middle portion of the time, even when a three-hour charge is run. If the charge is allowed to remain in the retort for five or six hours, during the latter portion of the time little or no gas would come over, and after the end of the third hour the heat of the retort would constantly increase, according to the conditions under which combustion is effected in the furnace, and the escape of heat from the bench by radiation and otherwise. In fact, were we able to get at the actual conditions in the retort during the time the coal is being distilled we would probably find that great changes were taking place; and in proportion to the degree or variation of these changes or conditions we fail to secure perfect work.

With a furnace capable of generating and keeping up, or constantly maintaining, the necessary quantity of heat, because of there being no necessity for drawing the fires for clinkering the furnace, and thus allowing draughts of cold air to cool off the retorts, we are able to secure a greater quantity of and a more constant heat in the retorts; and in drawing the charge at the end of three hours the more extreme conditions are avoided. Thus we have one explanation of the reason why we are able to carbonize more coal in a retort during the 24 hours than is possible to do with the old-style furnace, with which four or more hours for the proper carbonization of the coal is a necessity.

Formerly it was said that if over 4.50 or 4.75 cubic feet of gas per pound was extracted from the coal, trouble with naphthaline was sure to follow; but I have seen the flow of gas through the inlet and outlet pipes of a gasholder very greatly impeded by the deposit and accumulation of naphthaline, even when the yield of gas per pound was less than the minimum figure above given. Again, when the use of oil and naphtha was commenced, it was said that naphthaline would never be deposited; but it is no uncommon thing to hear it said that greater trouble takes place when oil is used. Within a few months samples of a mixture of hard soot or carbon, naphthaline and tar—the mass somewhat resembling soft coal—were shown me that were taken from the hydraulic main and tar tank, being the results of an accumulation following the use of oil as an enricher.

There is, no doubt, truth in the remark that blind prejudice and bigotry exercise too great an influence on our minds; and that is equally true whether these influential factors pertain to the manufacture of gas or to religious or other affairs. We are too apt to jump at conclusions, and too prone to decide without proper investigation into cause and effect. At one of our meetings, held some years ago, during a discussion on condensation and elimination of tar from the crude gas, a member was asked how he got the tar out of his gas. His prompt answer was, "I knock it out." While his answer excited a smile then, it embodies a recognized principle now. So it is to-day; if we should visit a retort house where three-hour charges are the rule, and should notice a stopped stand-pipe, the first remark would probably be, "I told you so." Again, if we should see a scrubber stopped up with an accumulation of naphthaline, we would be very likely to attribute the cause of the trouble to charging every three hours; or as if no such trouble happened where the retorts are charged but once during every four or five hours.

During the spring and summer of 1880, having visited the Peoples Works at Baltimore and examined the practical working and results obtained by Mr. Dieterich with his furnace—which at that time was the only one constructed upon principles almost entirely different from the furnace in common use—we made arrangements with him to introduce them into our Langley street Station at Providence. We first constructed a stack of eight benches, set back to back, and fired them up the latter part of the same year—that is, 1880. As we had other benches in operation at the same time, we could not determine the results obtained from this stack of benches save by the quantity of coal which they carbonized. We started and continued for a short time on four-hour charges; but finding we had no difficulty in securing almost any degree of heat desired, and acting under the advice of Mr. Dieterich, we changed from four to three-hour charges, and have continued them without interruption since that time.

We find that although we handle more coal, yet the cost of labor per thousand cubic feet of gas is less than when four-hour charges were the rule. Less labor is required to take care of the furnaces. Circumstances and conditions, as well as proper management, govern the cost of labor in the manufacture of gas. In small works the coal may be near at hand, so that the stokers can wheel it into the retort house. At other works the coal may have to be wheeled or carted a longer distance, thus necessitating increased cost of labor. Latterly mechanical appliances have been brought into use for handling the coal, which innovation has reduced the cost of labor.

On a subject of such importance much more might be said, but I have already taken up too much of the time of the Association. In December, 1878, Major G. W. Dresser visited Mr. Dieterich at the Peoples gas works of Baltimore, and made an examination of the operation of the Dieterich fur-

nace, in connection with three-hour charges, results obtained, etc.—the conditions in the main being similar to ours, with the exception that our arches are 7½ ft. by 9 ft., and formerly took the ordinary 14 in. by 26 in. by 9 ft. retort, but we now use the Davison retorts; and the investigator thus summed up his conclusions:

"1st. A more perfectly uniform heat throughout the bench than I have ever seen by any other method. The retorts appear to be uniformly heated up to the mouthpieces. The upper and lower retorts are heated alike. There is no flame to be seen in the bench by taking out any of the stoppers. There is no flame at the chimney top, or top of the bench, excepting at the moments of clinkering. No cold air can possibly get into the bench.

"2d. The charges are as thoroughly burned off in three hours as they would be in four hours by the old method.

"3d. The illuminating power of the gas is fully equal to that obtained by the old method, with the same coals, and a slightly smaller percentage of cannel.

"4th. The character of the labor required of the men is not nearly so trying as by the old system. The stokers have no fires to attend to or clinker, which all know is by far the most exhausting labor in the retort house; and, although they have to charge and draw oftener, the work is easier than when the fires have to be attended and the charges no less frequent.

"The skill required for keeping the fires going and keeping the heats up is reduced to a minimum, as one man can attend the fires for 14 benches with great ease, and, from the arrangement for clinkering, very little practice will enable anyone to manage the fires. In case of a strike this is an important item.

"5th. One-third of the coke made is more than enough to keep the furnaces supplied with fuel, although this would depend upon the character of the coal used and the nature of the coke obtained from it."

Discussion.

Mr. Harbison—I am not entirely familiar with the working at Providence, and I would like to inquire whether Mr. Slater adopted three-hour charges at both stations, and in making all the gas produced on the Providence works.

Mr. Slater—We have.

Mr. Cole—What is the difference in the weight of coal charged as between three and four-hour charges?

Mr. Slater—As said in the paper, our retorts are larger at the back end, and so take a little more coal, than the ordinary ones. We charge all the way from 260 and 275 pounds up to something over 300 pounds, every three hours.

Mr. Cole—Did you charge the same weight when you ran four-hour charges?

Mr. Slater—No; we would make a little difference in the rate when running four-hour charges. We would not carbonize the same quantity of coal in 24 hours that we do in running three-hour charges.

Mr. Harbison—For practical working, then, the facts are one can carbonize more coal and produce more gas per bench by running three-hour than when running four-hour charges.

Mr. Slater—Yes; provided you have the necessary heat.

Mr. Harbison—As I understand it, you have no trouble in getting the requisite amount of heat to carbonize three-hour charges; and that, as you can get the requisite amount of heat, you can get better results in quantity of gas made by working three-hour charges than when working four-hour charges. Not only so, but at the same time you reduce the cost for labor. The latter is the only point in which there is a reduction, except that you get a larger quantity of gas per bench—which, on repairs account, if the retorts will last as long, would be also a gain. I would like to ask Mr. Slater what his experience is in the matter of percentage of coke used in three-hour charges when compared with that burned with four-hour charges.

Mr. Slater—As a rule, I think we use, on the average, a little over 25 per cent. As stated in my paper, many think that because we run three-hour charges we are running under excessively high heats. Such is not the fact. We do run at a good, high heat, yet if we ran much higher than many of you gentlemen do we would melt everything down. It is simply a question of keeping the heat constant, and not allowing the retorts to be cooled by dropping the fires and clinkering, or by allowing cold draughts of air to go into the furnace and bench.

A Member—Do you think you would obtain the same results from the D-retorts?

Mr. Slater—I do not think we would carbonize quite as much coal. I think there would be a difference in favor of the retorts we are using. We have not tried the ordinary retorts with the Dieterich furnace, but from the time we commenced using that furnace we were able to carbonize a considerably greater quantity of coal with the Davison retorts. Although we have not tried the ordinary retorts with the Dieterich furnace in running

three-hour charges, I think that we would carbonize more coal with the Davison retort, for the latter has a larger floor surface.

Mr. Littlehales—How do you account for the saving in labor?

Mr. Slater—One man is able to take care of a greater number of furnaces, and that permits the stokers to attend solely to their duties of drawing and charging.

Mr. Littlehales—But, given a certain number of retorts for a given amount of work—say two benches of sixes—and that puts more labor on those men if they have to charge every three hours than if they charged every four hours. Is it because you are getting more out of the same men, or is there greater facility in some other way? Where can the labor be saved?

Mr. Slater—I think, as a rule, the men do handle a little more coal. I am not able to state from memory exactly what the cost of labor is now, but it is considerably less than it used to be.

Mr. Hyde—What percentage of coal carbonized can you get from three-hour charges over that obtained from four-hour charges? How much more coal can you carbonize?

Mr. Slater—I would have to figure that up before answering.

Mr. Stiness—The charges are a trifle lighter than they would be in four-hour charges, and you charge a little oftener.

Mr. Slater—They are a little lighter, but the fact of being able to get in two extra charges in the 24 hours more than compensates for that difference.

Mr. Hyde—Is the cost for fuel, in proportion to the coal carbonized, less in three-hour charges than it is in four-hour charges? Would it take more fuel to the ton of coal in carbonizing three-hour charges than in the case of four?

Mr. Slater—It takes less.

Mr. Stiness—What is your daily average yield per mouthpiece?

Mr. Slater—During last year I think the average was something like 11,400 feet.

Mr. Hyde—In 1878 I made an experiment with three-hour charges. I first ran a bench four hours, and ascertained the result in pounds of coal carbonized, and also the amount of fuel used. Then I tried, for the same length of time, the three-hour plan. The figures showed that we carbonized 13 per cent. more coal, at a cost of 6 per cent. more for fuel used per ton of coal. That is, it took more fuel to carbonize a ton with three-hour charges than it did with four.

Mr. Slater—Did you fire with hot coke?

Mr. Hyde—No; with cold.

Mr. Slater—We fire with hot coke.

Mr. Beale—How large are your retorts?

Mr. Slater—I have not got the number of square inches of floor surface in mind, but I have stated it several times. It is something larger than the ordinary retort.

Mr. Stiness—Is it really any more work to charge every three hours? Do the men notice the difference in labor?

Mr. Slater—I do not think they do. We never heard any objection to it.

Mr. Spaulding—Are the results obtained so satisfactory to yourself that you propose to continue three-hour charges?

Mr. Slater—We have been continuing them for five or six years, and we do not propose to change.

Mr. Lansden—Do you find that three-hour charges wear out your benches any quicker than four-hour charges?

Mr. Slater—I do not know that I see any special difference in that. We have had retorts last for three years; and we have used them up in one year. The last stack reset consisted of eight benches, and the average life of each retort, for the whole bench, was 532 days. The average quantity of gas produced by each retort during its lifetime was a fraction less than six million cubic feet.

Mr. Cole—Is there any difference between three and four-hour charges in respect of the accumulation of carbon?

Mr. Slater—We did not notice any difference in that regard.

Mr. Sherman—What yield do you get per pound?

Mr. Slater—Taking it for the whole year, we will not vary much from an average of 5 feet.

Mr. Sherman—How much more would you get if you had four-hour charges?

Mr. Slater—I do not think there would be any noticeable difference. I think we really get a better quality of gas by dropping off the last hour. You who run four hours know that the poorest quality of gas is obtained in the last hour of the charge. We get a better quality of gas in three-hour charges than we would in four.

Mr. Sherman—You get the same yield, and charge the same quantity of coal in three hours that you did in four?

Mr. Slater—We get the same yield per pound, but we have a better candle power.

Mr. Cabot—You spoke of getting 5 feet per pound of coal. Is there any enricher with that?

Mr. Slater—During the last year we used cannel as an enricher.

Mr. Cabot—In what proportion?

Mr. Slater—In the coldest winter weather we used about 10 per cent.

Mr. Taber—The President has put in some new benches, and I would like to ask him if he has used three-hour charges.

The President—We have never tried three-hour charges at Syracuse, but have occasionally compared results with Mr. Slater. We charge more heavily than he does. I remember that last July he had some very handsome results from 20 days' running in that month—perhaps a little above the average of the working results for the year. He thought the figures were good enough to send to me; and on receiving them I turned to our carbonization book, took off a statement for the corresponding days, and sent it on to him. I extended a column (he did not have it in his statement) in the item of "candle feet." In the production per mouthpiece Mr. Slater had beaten me a little, though not very much; but in the column showing candle feet merely I beat him quite handsomely. We have compared results from time to time, and there is not a great deal of difference in our working results as between the two systems of three and four-hour charges. He uses a somewhat lighter charge of coal. His work is all done with a regenerative furnace; ours only in part. With us about 66 per cent. of the gas was manufactured by the regenerative furnace, and the balance with a furnace of the common sort. Of course we had to excel him in the candle power of our gas in order to lead him in candle feet. We do not use as much cannel as he does; but that is all owing to the apparatus we have for manipulating the gas. With our apparatus we find it necessary to use not to exceed an average for the year of about 5 per cent. of West Virginia cannel.

Mr. Slater—Mr. Beale inquired the relative difference in floor surface. In the retort that we use the approximate number of square inches is 2,924; in the ordinary retort it is 2,600.

On motion of Mr. Cabot, a vote of thanks was tendered to Mr. Slater.

The President now called upon Captain W. Henry White, of New York city, to read his paper entitled—

A NEW DEPARTURE IN GASHOLDER HOUSES.

The author read as follows:

In no other portion of the work incident to the erection of a gas works is the serious attention of the engineer so challenged as in locating, designing and constructing the gasholder and its tank. Frequently this is the only part of the work calling for more than ordinary skill and judgment. The contiguity of valuable structures, the nature of the soil, and labor of excavating to great depths, the haps and mishaps of fitful weather, all combine to make this a work of the first importance, outside of any consideration of its heavy cost.

Granting these facts of cost and skill implied in holder construction, the engineer has but partially satisfied the requirements of his work, who will be content to leave, to the mercy of the storms of our northern latitudes, this important and costly structure without some earnest effort to secure proper covering buildings for its protection. To the engineer the necessity, advantages and economies of such protection are evident facts; but to the directors, who rule the financial affairs of the company, the other equally potent facts—increased cost of construction and additional interest charges—are too frequently permitted to outweigh the known benefits to be secured; and this possible, but to their minds somewhat intangible, benefit is lost sight of and sacrificed to present economy—into whose capacious maw many well designed improvements pass yearly. Experience comes to us through many channels; and pleasant, or the reverse, is no less costly to the gas engineer than to his fellow man.

Years ago the writer stood, in a heavy snow storm that made doubly dark the wild and threatening night, and with emotions as deeply stirred and tempestuous as the ever-shifting wind about him, looking at the wreck of what had been his largest, newest and best gasholder—a much-needed and reluctantly-granted increase of storage room in a works with a daily output that then trebled its holder capacity. As I contemplated that wreck, and considered whether a punishment could be invented adequate to the deserts of the faithless employee whose carelessness had aided the power of the storm, and recalled the pressing demand of the district in the then holiday season for gas, it may safely be asserted that no mourner at the memorable "Burial of Sir Johu Moore" could possibly so "bitterly thought of the morrow."

Out of the experiences of that wild night, and the recollection of the anxious days that followed it, came a firmly settled resolution to always house a gasholder whenever the decision upon the matter rested in my control.

Naturally the entire ground of discussion bearing upon the practical value of these covering structures has been well and thoroughly ploughed in the intervening years; and all the holders constructed under my charge during those years have not been "housed"—"old times and old manners" change slowly, and to those of us who, more impatient, would make things move

more rapidly, is committed the removal of such stumbling blocks as lie in the pathway of the special reform or change we personally desire. Admitting, as most managers of gas companies readily do, that a covered holder is in all senses a much better apparatus and more efficient than an exposed one, what is the reason that to-day so many costly structures are daring the elements throughout the stormy northern country? Experience answers that the costly character of the buildings necessary to protect these holders has prevented their erection. "Vanity of vanities" are all the arguments upon the subject of the many small savings, the added duty of the holder, and the security when Present Cost—with a large capital P—stands watchdog over the treasury. To secure, therefore, a covering structure, substantial and durable, amply protecting and guiding the gasholder, at a cost little, if any, in excess of the suspension frame used on exposed holders, became one of the objects of my engineering quest. This might be secured by a frame house, but so many good objections hold against such a structure that it was given only a brief consideration.

The whole gamut of brick and stone buildings, with various ideas of roofs, was run through at all sorts of times, in all sorts of places, in hope of finding some construction that would touch the happy medium between cost and substantiality; but gradually faded idea after idea, plan followed plan in dreary procession across the drawing table into the waste basket, and the search would languish. But the fatal poison was in the blood, and again and again that holder-house was in hand. It had been taken to church, to theater, to horse races, to bed with me; it became a veritable "Old Man of the Sea."

City life gives us many new ideas with its daily object lessons, its ever-shifting kaleidoscope of sights, and, without knowing just how, we frequently imbibe a valuable suggestion from the most unpromising source. When I say that my "long days of anguish and nights devoid of ease" found surcease from the suggestions from an exhibition of a novel fire escape ladder—at which I "assisted" the assembled boot-blacks and newsboys on lower Broadway one sunny day—the connection may not seem clear, and the relations between that iron ladder and my recent achievement in holder houses seem "rather far fetched," but that was the germ, the ovum out of which the present structure was hatched.

I will not further take up your time to give in detail the intervening steps by which my fire-escape ladder grew into a lattice girder and roof truss, and that into my covered suspension frame (for after all that is the story of the house in a sentence), suffice it that it grew in the odd hours of a busy life into definite form and feature, when, abandoning all other material, the construction of the house entirely of wrought iron was decided upon. The framing of a building, in Chicago, for the housing of a war cyclorama, by a daring architect, in much the same line of work, gave me the longed-for opportunity to study out several unsettled points in construction, and supplied valuable data as to strength of materials and strains; but, beyond all, positively settled the question of cost. The next step was taken this past summer in designing such a housing for the St. Paul (Minn.) Gas Light Company's holder, and the "new departure in gasholder houses" was made. I regret at this writing I cannot say that it is a completed work. Our friends, the Knights of Labor, contributed their share toward delaying the commencement of the work; the rolling mills added their quota; while sub-contractors on the work seemed, in many things, to study "how not to do it;" but for all practical purposes the building is sufficiently completed to show the correctness of the plan of the designer.

Description of the Building.—The size of the holder and its covering

building was forced upon the designer by the necessity of securing, upon a lot 100 ft. by 100 ft., the utmost storage capacity compatible with its dimensions, safety, and any pretense to preservation of architectural symmetry in the structure. Resultant from this problem is a tank of brick 91 ft. 6 in. inside diameter, and 26 ft. deep, with walls varying in thickness, from 4 ft. at bottom course to 2 ft. at top. The tank has 8 piers, 4 ft. deep by 3 ft. wide. The loose sandy soil in which the tank is built necessitated intermediate piers for sustaining the pressure of water in the tank, and the lot, being upon a sharp slope of nearly 11 ft. from its upper to its lower side, involved the introduction of a retaining buttress wall on the lower side. The gasholder is a triple lift having a trussed crown. Its several sections are of following dimensions:

- Lower section 89 ft. 6 in. by 25 ft.
- Middle section 88 ft. by 25 ft.
- Upper section 86 ft. 6 in. by 25 ft.

The building, which is to act as guide frame and covering, is constructed entirely of wrought iron; is octagonal in shape, 117 ft. in height, over all, 93 ft. 6 in. in inside diameter, and 78 ft. in height from curb to foot of roof.

Each of the eight sides of the building has three windows in its elevation—excepting the two sides which are fitted with doors. These contain but two windows each. Thus, with 22 windows and two double doorways, the need for light, ventilation and facility of access has been amply provided for. The roof is an octagonal pyramid, having a rise of 27 ft., and is surmounted by a lantern conforming to the shape of the main building, and of proportionate size. This lantern is fitted with eight small windows, and the single piece of cast iron in the body of the structure constitutes its finial cap. The entire structure is covered with No. 26 corrugated galvanized plate iron, riveted together, and securely fastened to the framing.

The frame is composed of eight wrought iron lattice girders, each constructed so as to form a continuous girder from pier-head to compression ring in the roof. These girders (or principals) are built of heavy angle iron, reinforced at the point where they curve from the vertical to horizontal incline (to form the roof trusses) with plates of boiler iron. They are 3 ft. in depth by 7 in. on the face at the pier-heads. A little below, and again be-

yond the point of divergence from the vertical line the lattice widens to 4 ft., but decreases from that to 2 ft. at the compression ring. The foot of the lattice is fastened to a cast iron sole-plate fitting the pier-head, to which this plate is secured by the usual holding-down bolts built in the piers. The upper end of the lattice is fastened to the compression ring by angle plates, and a ¼-inch boiler plate, canonical head, which extends down the truss 18 inches, and to which it is securely bolted. The uprights are spaced 38 ft. ½-in. from centers on outside chords. The compression ring is 10 ft. in diameter, and 2 ft. 3 in. deep, and is built of ½-in. boiler iron, strengthened by angle iron curbs. The eight girders and this ring form the principals, both of the building and of the roof, and are, at the same time, the suspension frame for the gasholder. The diagrams distributed to you possibly convey a clearer idea of the arrangement of these lattice girders and the frame generally than my description, and I invite your attention to them.

Fig. 1 illustrates the framing; fig. 2 the roof plan; and fig. 3 the footing of the girders upon the pier-heads. The girders are tied together at the foot of the roof by a 16-inch channel beam, tension member, and at two lower points by two 9-inch channel beams, all extending around the whole building, giving it great stiffness. The spaces between these beams are subdivided by six 2½-inch and nine 1½-inch angle bars, alternating, and also ex-

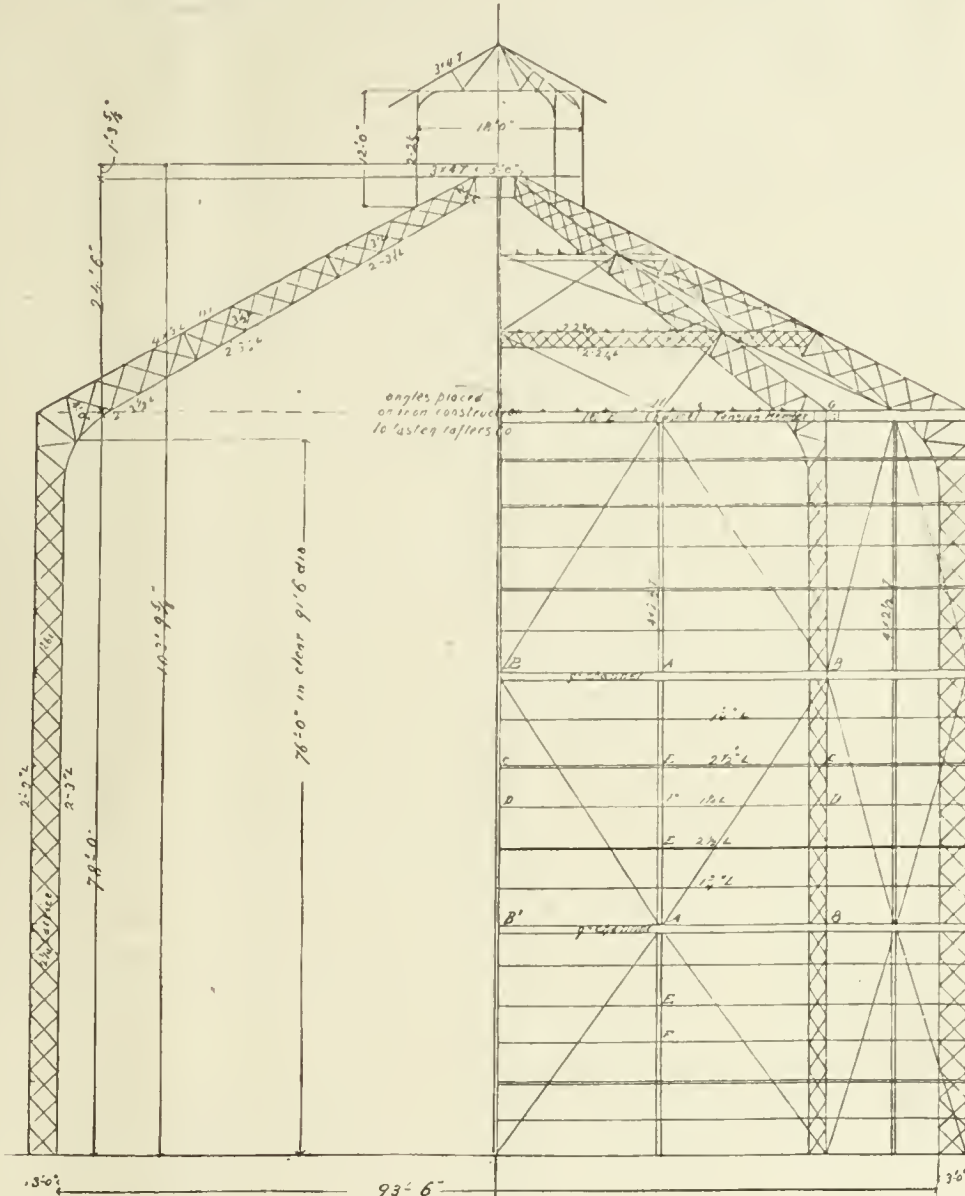

Fig. 1.

tending around the building, to which the corrugated iron plates are fastened.

A secondary framing is secured by dividing the vertical spaces between the principal trusses with a 5-in. by 4-in. T-iron upright, which extends from the bottom curb to tension member, and is securely riveted to each channel beam and angle iron at its intersection.

Diagonals of 5 in. by $\frac{3}{8}$ -in. bar iron, springing from the principals, are secured to this T-iron upright, and, uniting with the diagonal bracing of the roof, form a continuous brace from side to compression ring through the whole framing.

The roof trusses, formed by the lattice principals, are bonded together, at a point 15 ft. above the tension member, by a lattice work girder, 24 in. deep, constructed of 2 $\frac{1}{2}$ -in. by 2 $\frac{1}{2}$ -in. angle iron, and 2 $\frac{1}{2}$ -in. by $\frac{3}{8}$ -in. bars. At another point 30 ft. 6 in. above the tension beam a plate girder is bolted between the trusses. These circular struts also serve the purpose of supports to the secondary rafters of wood, 2 in. by 8 in., upon which the board sheathing of the roof covering is laid down. Diagonal braces of 4 in. by 2 $\frac{1}{2}$ in. T-iron are introduced between the tension beam and lattice work strut, and of 1 $\frac{1}{2}$ -in. round iron between the lattice and plate struts, to give additional strength to the roof.

The lantern is strongly framed of angle and T-iron, suitably braced, and is securely bolted to the main girders, and is covered with same plating as the main building.

The windows, numbering 22 large and 8 small ones, are all wooden-framed, double-sashed, and have twelve 8-in. by 12-in. lights of glass each. The two double doors are plain, panelled, wooden ones, 7 ft. 6 in. high by 2 ft. 6 in. wide, and have glazed segment heads.

The cost of this building completed was \$10,000, but the experience gained in erection will tend to diminish this cost in similar structures; for like all ventures into new fields—even though, as in this case, it is only the application of well-known material and principles of construction to new uses—better arrangements are suggested by the practical work of erection and use. While the writer now sees where changes might be of advantage, yet the structure as it stands is an ample demonstration of his theory that a substantial, fire and storm-proof holder house can be erected at an expense not exceeding, if even equal to, the cost of a properly-designed suspension frame. Nor does he feel that the use of such a construction must necessarily be confined to the larger holders, but would apply it to holders of sizes ordinarily found throughout the country.

Without claiming any of the laurels of an inventor, the writer modestly presents this idea of covering holders to the thoughtful consideration of his fellow members, confident that they are impressed with the need of some such economical answer to a problem we have all, in one manner or another, been forced to give attention to.

This paper would be both incomplete and unjust did it fail heartily to express the obligations of the writer to the Union Foundry Company, of Chicago, the contractors for the construction of the building, to whose engineer, Mr. Morava, and architect, Mr. F. W. Barker, he is largely indebted for practical help in completing and successfully carrying out many important details of the structure, and in its subsequent erection.

Discussion.

Capt. White—I omitted to state in my paper that the inner face of the upright girder carries an ordinary T-rail extending from the top to the bottom of the girder, forming a guide rail for the holder wheels.

Mr. Greenough—I suppose you cannot get around that rail and go between the different girders.

Capt. White—The diagram distributed to the members was made from the original plan, and does not show the subsequent alteration which provides for a passage around the holder, which passes through the girder. This cut in the girder is 5 feet high, and gives a clear way around the coping of tank. The house could not be made larger, for it now covers entire surface of the the lot.

Mr. Greenough—What is the size of the girder?

Capt. White—It is 3 feet wide at the base, and 7 inches wide on the face.

Mr. Harbison—I would like to ask if such an arrangement could be put over a holder now in use, and built with cylinder columns. If placed on the tank walls, how then could you get around it, in case of necessity, without going outside?

Capt. White—You would have to get between the holder and the column as it now exists. If there was not room to do that, then you would require doors between every other column.

Mr. Crafts—Have you seen the three brick gasholder houses in New Haven, Connecticut?

Capt. White—I have not.

Mr. Crafts—I was about to ask how the cost of yours compared with those. They are built of brick and covered with an iron roof. Everybody knows that a brick house is preferable to an iron one. At Connecticut they had to put in double sash in order to keep the cold out, and to keep the tanks from freezing. I do not see any advantage in the iron house at St. Paul over the brick houses in New Haven.

Capt. White—The only advantage, as between brick and iron, is the relative cost. This house can be erected cheaper than any house I have ever seen built.

Mr. Crafts—I think the New Haven houses are the most complete of their kind that I ever saw.

Capt. White—Your experience in that direction is, of

course, very much superior to my own. I have not yet found a holder house built as cheaply as I can build this. I simply present it to the members as something that I felt we were all looking for—a method of covering our holders at a cost which would not be a bar to the construction of such a building. In my own experience, and with such observations as I have been able to make, I have not yet found a holder house that was as cheaply constructed as this. Of course, I cannot refer to those at New Haven, for I am not familiar with them.

Mr. Greenough—I do not know anything to prevent the filling in of the interstices between those girders with brickwork, if it is cheaper to do so. Of course, it would give much greater protection against the cold if the walls were built of brick, rather than of corrugated iron. Being built of corrugated iron I do not suppose they would protect the tank from freezing, although they would protect it from wind and storms.

Capt. White—I had in mind the very low temperature of St. Paul, and I

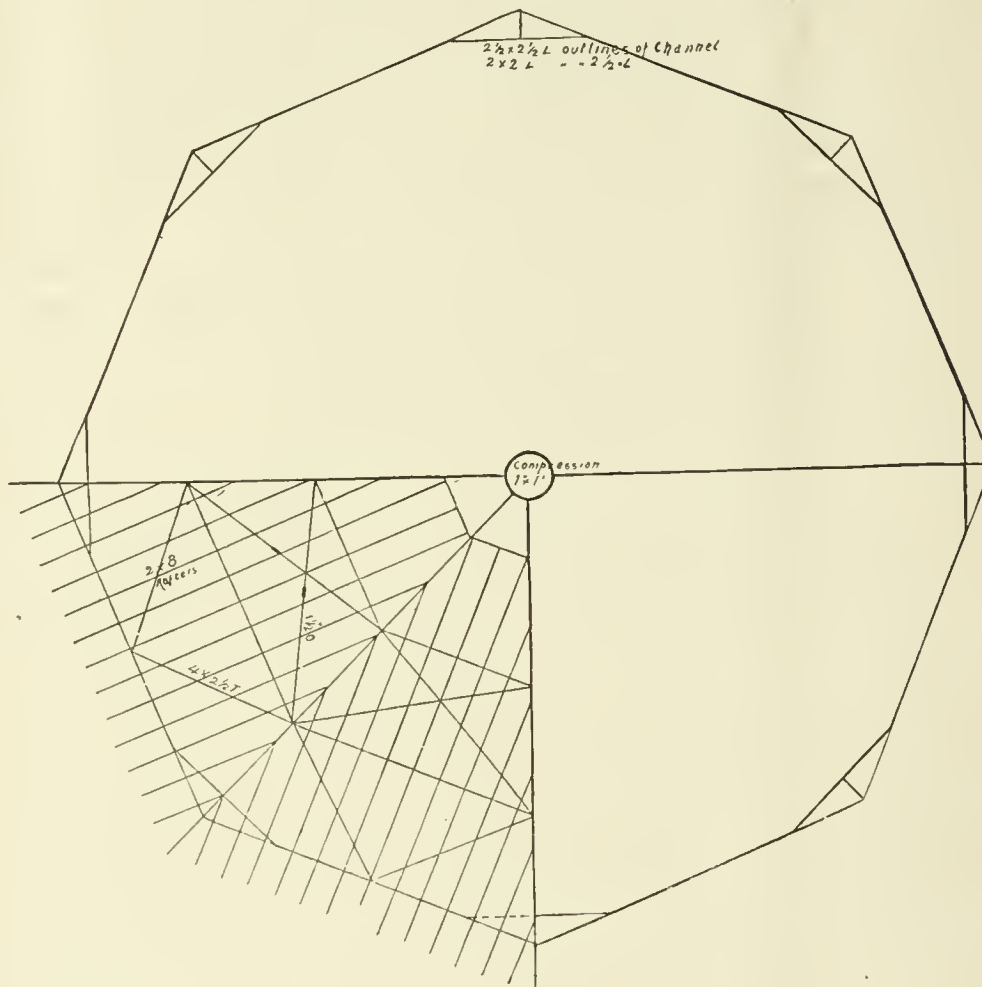

Fig. 2.

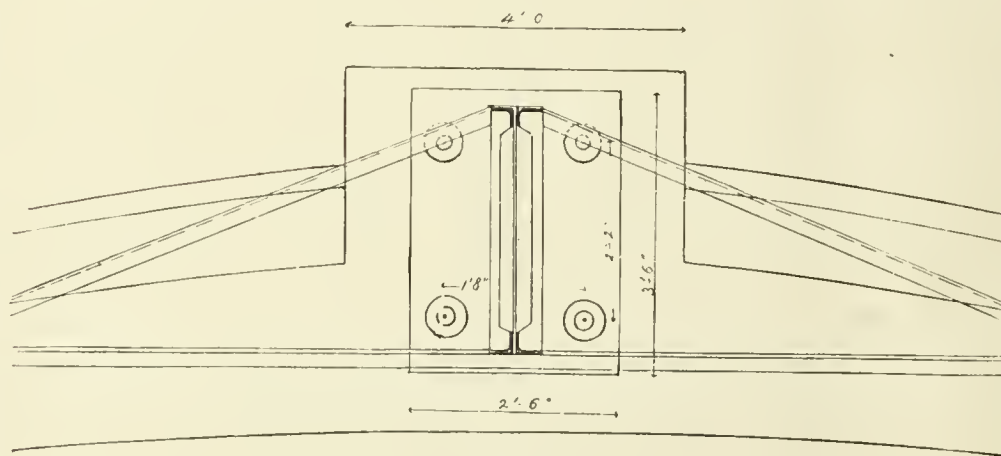

Fig. 3.

knew that I could heat the space between the holder and the outer covering without any difficulty, and so prevent the holder cups from freezing. But, of course, not having tried it, I cannot say what the result will be.

Mr. Greenough—It will be a matter of interest to the Association next year to know whether that can be done.

Capt. White—We know that a very little steam will keep a gasholder cup from freezing. If we simply succeed in protecting the holder from the wind and snow storms in that high latitude, we are willing to take the chance of keeping it from freezing. But my own judgment now is that it would be better to sheathe the whole holder house with wood under the iron, the same as arranged for the roof; and that plan has been adopted, and the iron plates put upon the wood sheathing. I think that makes a perfect house.

Mr. Greenough—I think that would add very much to the effectiveness of the house. The suggestion of ideas like this is exactly what this Association is intended for. It is desirable that we should have new matters of this kind presented to us, and then we can reflect upon them. It hardly gives a person time to make up his mind to the efficiency of a scheme like this, simply to have a drawing presented, and a paper read, and then have the matter passed over and something else taken up. The experience of everyone is of interest; and I may say that we have seven gasholders with buildings over them at Boston; but when we came to construct a holder 200 feet in diameter we made up our minds not to house it. A holder of that kind without a house, to be safe, must be near the gas works, so that the men can get readily at it; and it requires a great deal more care than when it is put under cover. I think that a scheme like this, which provides for economically covering a holder, is worthy our consideration. I have seen the drawings of a covered holder 200 feet in diameter in which the roof rests on a center pier; and then, instead of having guide frames all around the outside, the holder was worked on the pier which ran up in the center of it. The holder is then made very solid. I also think that the drawing which I saw showed a lining of felt on the inside of the building as a protection against cold. We made up our minds that that was too expensive, and that we would risk it without any covering. A scheme of this kind is of very marked value, and worthy the consideration of the Association.

Capt. White—The cost of housing the holders of the Chicago Consumers Gas Company was something frightful. I had gone into the housing of those holders without making close estimates, and I carried my directors along with me, upon general principles; but I was perfectly startled when I came to realize how much money was expended in the substantial structure erected. It is probable that it will be returned to them in the course of years, but that experience made me very much more anxious to find some simpler method of solving this problem.

Mr. Helme—I think that Capt. White, in his very clear and succinct statement, has omitted to give us an idea of just what the difference is in cost between constructing a holder of this kind under cover, and constructing a holder of similar kind, but covering it in the way that has been usual up to this time.

Capt. White—The difference in the case under consideration would have been over \$3,000—*i. e.*, between a brick house and that erected at St. Paul, figuring, of course, on the cost of brick at St. Paul. I, therefore, saved that sum on the St. Paul house.

Mr. Littlehales—I must say the cost of Captain White's house seems to be very reasonable indeed, in fact, cheap, for a house of that size. There is one point, however, on which I have grave doubts. In a cold climate like that of St. Paul, which is much like ours in Canada, I would be very much inclined to doubt the safety of that house. Over and over again in our northern latitudes I have known iron roofs to break because of the strains becoming so severe on some one point. For instance, when the temperature is down to 15° or 20° below zero, some of the outside frame will be subject to immense tensile strain; and if there are any steam pipes inside of the house there will be a very great difference. It has been a matter of surprise to many gas engineers to find wooden roofs over retort houses in Canada; and it often evokes smiles from some of our Southern friends when they come through Canada and see our retort houses covered with wood. Our experience teaches us the wisdom of using wooden roofs; and I should be inclined to doubt the stability of this structure of Captain White's. Nevertheless, it certainly has the merit of remarkable cheapness. We built one as nearly the same size as possible—90 feet in diameter—with a double lift 20 feet high; and that house cost us, apart from the tank, about \$15,000. Capt. White's house is a little heavier than ours; but I take it that, in consideration of the greater expense of doing the work at St. Paul, it is a far cheaper piece of work than we turned out.

On motion of Mr. Greenough (seconded by Mr. Harbison), a vote of thanks was tendered to Captain White.

Mr. Arthur E. Boardman, of Macon, Ga., now read the following paper, entitled—

SUGGESTIONS UPON CANDLE POWER AND ILLUMINATION.

Mr. President and Gentlemen:—It was my desire and intention to have made some experiments during the past year upon the difficulty in reconciling candle power and illumination, and to have presented the results to you at this meeting.

Unfortunately I was prevented by sickness, lack of necessary apparatus, and press of more active duties, so that I have come before you with only a few suggestions upon this subject, which are offered in the hope that they may direct your observations and discussions toward this discrepancy.

My attention was first called to the disparity between the record of the photometer and the actual results in illuminating by an experiment made when I first took charge of a gas works, and when very energetic in striving to realize fame and fortune at a single bound by some grand discovery. A description of it may serve to make my meaning of the difference between candle power and illumination more clear, so I will relate it. I had, of course, noticed the effect upon the flame of the oil student lamp, produced by the contraction of the chimney, and I determined to apply this principle to the gas Argand. After testing my gas with the ordinary Argand and chimney, and finding it about 16-candle power, I removed the gas chimney and substituted that of a student lamp, leaving everything else as it was. Imagine my astonishment and delight when, on making the observation, I found that the gas was 22-candle power. Had anyone been near I should have exclaimed, "Eureka!" but being alone, I merely thought it, or words to that effect. The rest of the day my mind was filled with the methods to be pursued in having my discovery improved, patented, and properly advertised, and my fortune realized. Anxious to share my elation with the partner of my joys, I hastened home that evening with one of the student lamp chimneys. After tea I explained my grand discovery to my wife, and called upon her to witness the startling increase of brilliancy by simply substituting one chimney for the other. The effect indeed was great. We could easily look at and admire the rich warm flame of the Argand with straight chimney, but when the other was put on our eyes could hardly bear the direct rays from the brilliant point of light produced. Satisfied with this, we drew our chair and lounge before the fire, and on either side of the dazzling light, and prepared respectively to enjoy the evening in reading and sewing. Getting into a comfortable position on the lounge I opened my book and began to read. The printed characters, from some cause, were not as legible as usual, and I turned quickly to my better half, who was vainly trying to thread her needle, and asked if she had turned down the gas. She has not that excessive respect for me that my position at the gas works should command, and is capable of a practical joke at my expense when occasion offers. However, this time she had not tampered with the light, and was as much in the dark as I regarding the cause of the trouble. We concluded that our eyes were dazzled by looking directly at the flame, so we turned down the gas until we should become accustomed to the gloom, then turned it up again without looking directly at it, and tried the reading and sewing anew. The result was the same. I gazed around the room and upon the objects there to see if they, too, shared the depressing effect of this dazzling newcomer. Alas! the clock on the mantel seemed to have drawn a veil over its face; the statuette of Venus in the corner might have dropped her robe without impropriety; and the polished brass scuttle seemed to have come into intimate relation with the contents of the mercury cup on the gas fixture, so white and pale it looked. Everything pointed to a dismal failure, and seemed to say, "Beware of contaminating your gas by contact with even the chimney of an oil lamp!"

The straight chimney was reinstated; the warm, mellow light diffused itself throughout the room, and brightened up the despondent furniture. The needle was threaded, the book resumed, and nothing remained but the disappointment. Thinking the trouble might possibly be in the burner I tested it, at the photometer, with the two chimneys; but with the same results. There was always an increase of candle power, but a decrease of illumination; and I may add, the experimenter was made a "sadder and a wiser man."

Since that memorable event many things have occurred which have strengthened my belief that the photometer is not entirely reliable as a light measurer, and more especially where the lights are of different kinds. It did very well so long as the light of flames having very nearly the same temperature were compared; but when it is used to compare the flame of a substance burning in the open air, with the light emitted from the voltaic, or even with that of the same substance under forced draught, I think the arc comparison unfair to the light of lower temperature. Light and heat are analogous, and one might as well expect a small rod of iron, heated to one thousand degrees, to warm a room equally with a large surface radiator heated to 212°, as expect a small speck of intense light to illumine a space equally with a large flame of much less intensity. The photometer seems to be more sensitive to intensity than to volume, and for this reason is not reliable as the arbiter of the character of light we should sell for the purposes to which it is generally put. The high-power burners, producing an intense light by

reason of the high temperature at which the gas is burned, and showing astonishing results as to candle-power per foot of gas consumed, are, in some degree, deceptive as to their power of illuminating space. Fortunately for them they also enlarge the dimensions of the light-giving flame while increasing its intensity, and, therefore, really increase the illuminating power, though not to the extent we are led to expect from the nominal increase in candle power. The arc light with its enormous—and if measured by the photometer it will much nearer approach the claimed two thousand than we wish to acknowledge—has not the illuminating power of the large Siemen burner claiming only five hundred-candle power. The incandescent light, showing actually sixteen-candle power by the photometer, has not the illuminating power of a ten-candle gas flame, and it is because of the extent or size of the exciting surface.

Examining the report of the Franklin Institute, as to the efficiency of the various incandescent lamps, I was struck with the fact that in those lamps having carbons with circular section the candle power was very nearly the same taken in every direction on a horizontal plane, thus indicating that the photometer took no cognizance of the light-giving surface exposed to it. That is, the candle power was the same when the plane of the loop was at right angles to the bar as when in the same plane. In the first instance the entire loop was exposed, but in the second one side of the loop must have been behind the other, and the illuminating power in that direction must have been less, though the candle power remained the same.

In a flat gas flame we know the illumination is less in the plane of the flame, although that is comparatively transparent. The photometer indicates this because the difference in surface exposed is many times greater, and the intensity of the two flames compared—the candle and gas—are more nearly equal; still the difference in candle power indicated is not commensurate with the actual difference in illuminating power.

It would be of great interest to us, and possibly of great value, to have at our command reliable data of photometric observations upon equal areas of the different flames and incandescent substances used for illuminating. Could a gas flame, for instance, be projected full size upon cross-section paper, with lines one-eighth of an inch apart, and each one-eighth of an inch area have its illuminating value determined with relation to the one-eighth of an inch of metal heated to a certain temperature, we would be able to arrive more nearly at its value as an illuminating agent by the sum of the values of each unit of surface. Other flames could, in like manner, be compared, as could also incandescent substances other than flames, and even the arc light itself. The future photometer may possibly be of this character, having, as the unit of light, that emitted by a certain area of metal heated to a certain temperature. As temperatures are difficult to maintain and ascertain, electricity may be called to our aid as a means of heating the standard metal, by passing a current of known and constant strength through a strip of the metal having a known and constant resistance.

The experiments of the British Lighthouse Board have, I think, demonstrated the fact that a light of great intensity and small area will not illuminate and penetrate a fog so well as one of less intensity and large area. As the atmosphere is always in a condition approximating more or less to fog, the small, intense lights will not illumine so large a space as the large ones of less intensity. The reason is obvious. Every particle of dust or vapor casts a shadow, and the smaller the surface of the light the longer that shadow, and the more likely it is to reach and overlap the shadow of the next particle; while the larger the light-giving surface the shorter these shadows, and the more easily does the light penetrate. Again, the large light illumines more of the surface of each particle, and is, therefore, better diffused by reflection from these surfaces, and the shadows are thereby made less intense.

The color of light used for illuminating space has much to do with its value, though the photometer may not indicate it. Yellow is called the most luminous of the rays of the spectrum, while the more of the blue we get the more dazzling the effect, but not the more luminous. The light which penetrates further through the atmosphere, and in greater quantity, is the red spectrum, the blue being arrested or reflected. The red of our sunsets shows the power of the red and yellow light in penetrating great depths of atmosphere, with dust and smoke in suspension, while the color of the sea indicates the portions arrested and reflected. This is doubtless due to the greater amplitude of the vibrations of the red and yellow light which causes them to overcome obstacles in their path that would be insurmountable to the quicker but less ponderous blue; for, though their rate of transmission is the same, their momentum, as it were, is greatly in favor of the red. Like the harmony of music pervading space, so is light; and as the shrill notes of the orchestra travel as fast as the deep boom of the bass viol, so blue light, due to higher temperature, travels as fast as the red; but the bass viol is heard far beyond the reach of the fife, and the red light penetrates where the blue has become exhausted.

Therefore would I suggest that we strive to increase the illuminating power of our gas light, rather than imitate the electric promoters in securing

high candle power. Increase the size of our burner flames as well as their intensity, and do not sacrifice our yellow rays to secure their blue. We know that the gas flame, protected by a clear glass globe, is brighter and of greater candle power than the same flame protected by an opaline globe; yet is the latter preferred by the public whom we serve, even though it compels greater expense for additional gas. The reason, I think, lies in the larger exciting surface, for the entire globe becomes, as it were, incandescent, though of greatly reduced intensity; and also from the transmitted light being of more yellow tone. A yellow or amber globe of transparent glass will not answer so well, because, though the color may be all that is desired, the waves of light are not broken up and thereby so well diffused.

I fear that the present demand for high candle power, or rather intense lights, stimulated as it has been by the advertising devices of the electricians, has, in a measure, warped our better judgment, and that we are catering to a vitiated taste when we endeavor to light our interiors with few centers of intense light. I think we should strive in our lighting effects so to distribute our burners as to enable every object in the space illumined to be equally visible on every side without any areas of intense light or intense shadows. We are so constituted that our different sensations are closely related, and we must not do violence to one expecting to gratify another; hence we should be very careful how we disappoint that agreeable sensation of warmth and comfort, which always accompanies light, by substituting the cold and glaring for the warm and mellow.

Discussion.

Mr. Clark—I would like to ask Mr. Boardman if it is not by the amount of illumination that he gets the candle power. If the candle power is not simply a measure of the amount of illumination, and must therefore be commensurate with it?

Mr. Boardman—I think not, altogether. It seems to me that the photometer measures only the direct rays falling upon it, without relation to the diffusion which occurs from a large lighting surface reflected from other surfaces. The candle power, as measured by the photometer, is only a measure of the intensity of the wave proceeding in one direction; and while it is a correct comparison between two lights, as to the intensity, I think it is not a correct comparison between the powers of those two lights to illuminate the space in which they are situated. I do not exactly get your meaning, unless I have answered your question.

Mr. Clark—My meaning is about this: Light, as we know, proceeds from its source in all directions with equal intensity. We may take a certain section of light wave proceeding from any source, and measure it by comparison with a certain section of light wave from another and standard source; and it seems to me that that is an actual measurement of the luminous qualities of one light as compared with another. I cannot see how you can make a distinction between illumination and candle power, for that reason. Candle power is our recognized standard of illumination; and although the candle is not an exact standard, still it is the standard. At your disc you have a positive comparison between the amount of illumination that a candle gives and the amount of illumination that the gas gives; and that is called candle power. The system, it seems to me, affords good means of determining or measuring the illumination.

Mr. Littlehales—I think the point which Mr. Boardman raises can be very simply illustrated by a diagram. I think he is perfectly correct in the position assumed as regards the diffusive qualities of the two lights. We may illustrate it by a diagram in this way: We will suppose that an arc light having an area of a certain size, and a series of gas flames that will nearly equal that box in size (pointing to a box about ten inches cube). We may imagine a line of light starting from every point on the whole area of each; and it is very certain that, at a given point, you will get a greater number of light lines from the larger one than you will from the smaller. If you will try it by drawing it down to lines you will see what I mean. If you have from each little point lines drawn at every possible angle, as you proceed away those lines will diverge, and you have no point between from which new ones emanate; consequently the larger area from which they emanate will give you a larger number lines at any given point.

Mr. A. C. Humphreys—I quite agree with Mr. Boardman in regard to the distinction which he makes between volume and intensity. Nevertheless, I think the point which Mr. Clark makes is entirely correct. The photometer is a measurer of illumination at a certain point. A disc is there for that purpose, and we illuminate both sides of that disc. We do not want to mix up cause and effect. We have the effect right there, and we measure the illumination of that particular disc. I think the point which Mr. Clark made is well taken. The photometer is a measurer of illumination, and it measures it by putting in that disc at that particular point. I would ask Mr. Boardman, with regard to difference in the color of light, what sort of measurement he made, and how he found out about the difference in color.

Mr. Boardman—I will state, as I said at the outset, that I had no opportunity to make any direct tests; but the eye, it seems to me, is sufficiently sensitive to notice the difference in the color of the two lights. The point

which Mr. Clark makes is very correct. The candle power, as shown on the photometer, is a correct measure of the light emitted from those two points; but it is not a correct measure of the ability of these two lights to illumine space. That is my point; not that a single object placed between the two lights will not be illumined in direct proportion to the intensity of those lights, but that the space in which they are placed will be better illumined with the larger light—that the dust in the atmosphere will not have the effect of diminishing the light of larger area so much as it will the light of smaller area. Taking the intensity of the two lights as being the same—as indicating the same on the photometer—and your gas flame of three square inches area, giving almost the same as a very bright candle flame under a forced draught would perhaps give, you get a point of light giving a shadow equally distant between them; but you would find, when you came to use the light, that the light of larger surface would give you better results. I think it is due to the obstruction which always exists in our atmosphere. Could we measure these lights in space outside of atmospheric influences, and where there would be no reflection and no interference by dust particles, then the candle power as shown by the photometer would be very accurate; but where these things do exist I contend that the light with the larger surface is the better light for the purposes to which we apply light.

Mr. Greenough—It is very rarely, I think, that one has an opportunity of standing up and saying that he agrees with both parties to a controversy. Mr. Clark is unquestionably right, I think, in suggesting that the photometer is a proper measurer of light. On the other hand, I think Mr. Boardman is unquestionably right in the position he has taken—that you cannot measure the illuminating power of two gases by their relative light on the photometer. That I think is true. I do not understand as yet why it is so. I am sorry to say that it is some time since I studied physics; and I know that this question was not at that time brought up. It may be owing to the color; it may be in the carrying power of the different rays of which light is composed; it may be that the yellow rays carry further than the white rays; but it is unquestionably true that there is more light in a 16-candle power gas flame than there is in a 16-candle electric light. And I should maintain that there is as much power in a 20-candle power coal gas flame as there is in one from water gas which showed much higher upon the photometer.

Capt. White—I think that I am so very happily situated at present as to be able to throw some little light upon the varying capacities of the incandescent electric burner and the coal gas burner, both reckoned at 16 candles in their light-giving capacities. I happen to be the unfortunate, or fortunate, owner of gas works making coal gas, and also of an electric light plant in the same town. We have there some of our stores lighted with incandescent electric lights which we call 16 candles. Upon our photometer, the day we set them up they were 16 candles; but the deterioration from 16 candles to 12 candles is very rapid—almost precipitate. They seemed to hang at 12 candles for about a week or ten days; then they gradually descend to 7 or 8 candles, and remain there for the life of the lamp—which is variously computed at from 600 to 800 hours. The lamps we use are the Edison, and are guaranteed for 600 hours; sometimes they do not last six hours, but I have some old fogies which have been in use for nearly 2,000 hours. Upon the question of the diffusiveness of light, I may say that I have a store in Little Falls lighted with incandescent lamps, in which the lamps are nicely distributed, the woodwork is painted white, and there is every facility for securing the utmost duty of the "light of the future." Immediately adjoining that store is one lighted with coal gas of 16-candle power, and the gas is not nearly so well distributed; yet that store is better lighted than is the store supplied with incandescent lamps. I am gathering money from both sources, and can therefore speak in an unbiased way about both or either. I don't care which light a man has so long as he pays his bill, but remain an interested observer of the diffusiveness, lighting value, and cost of these two lights. I am probably also in a position to be able to say something from actual experience about the diffusiveness of coal gas and water gas in the same district. It is probably well known that I was one of the first of the regular gas engineers in this country to have anything to do with manufacturing and distributing water gas. I distributed it as water gas *per se*, and also mixed with coal gas in varying proportions. I have found this to be an absolute fact: Time and time again a gas that would measure upon my photometer over 20 candles, being made of one-third water gas and two-thirds coal gas, would not begin to diffuse and distribute the light in a room equal to 16-candle coal gas. In other words, I found that while my water gas would realize high illuminating power upon the photometer, it would not diffuse as well in actual use as the lower grade coal gas. It was intense, local, but not a diffusive light like coal gas. (Applause.) I feel that this is an Association of men who are interested in the business of gas making, and all should be anxious for the dissemination of facts. I have no prejudice either way in the question, for I am just as ready to build a water gas works, if called on, as I am to build a coal gas works; but here we should desire to know the truth. It is not fitting for

this Association to tie itself to any one belief and say that a man must be a coal gas engineer in order to be a gas man. (Applause.) It is an absolute fact, and may be demonstrated as a fact every day under your own observation, that water gas does not possess, nor does the electric light possess, the diffusibility of a good, well-made coal gas. That is an absolute fact which you can fully demonstrate to your own satisfaction. I have tried the experiment with coal gas, and then have lit the same room with water gas, and with water gas and coal gas mixed; and I say it is absolutely the fact that the room was better lighted when it was illumined with the 16-candle coal gas than it was with 20-candle water and coal gas mixed.

Mr. Wood—I once had a trial with some chimneys that were made, supposing they were going to shew a great improvement in illuminating. The man who made them brought them to me and asked that I would make a test of them on the photometer. I did so, and we obtained on the photometer test a 33 per cent. increase of light. Then we put them on some lamps to try them, but with them we could not get the light that we did from a plain chimney, and subsequently discovered that the fluting on the new chimney had such an effect on the photometer that it would nearly double the nominal light.

On motion of Mr. Lansden a vote of thanks was tendered to Mr. Boardman.

(To be continued.)

SPECIAL ENGLISH CORRESPONDENCE.

COMMUNICATED BY NORTON H. HUMPHRYS.

SALISBURY, Dec. 10, 1886.

The Board of Trade Returns.—The "Daily News" Gives Advice to Gas Consumers.—The Electric Light Gets Notorious.—Mr. C. C. Carpenter's Generator Furnaces.—A Big Bonfire.

The returns prepared by order of Parliament relating to all authorized gas undertakings in the United Kingdom, whether belonging to joint stock companies, to individuals, or to local authorities, for the year 1885, have lately been issued. This is the fifth year of the issue of these returns as an annual publication, and they now begin to indicate some approach to completeness, although there are several things which prevent the records from showing an exact return for the year ended Dec. 31st, 1885. Most of the local authorities make up their accounts, not to the end of each year, but to each 25th day of March, and therefore the returns relating to gas undertakings worked by local authorities who have availed themselves of the protection offered by Parliament, are made up for the year ended March 25th, 1886. Then in some cases the capital has been raised for gas and water works combined, and it is not possible to allocate the exact amount that has been applied for gas purposes. So the returns can only be considered as a fair approximation to a correct indication of gas affairs for the year 1885. These remarks do not apply to the quantity of coal carbonized, and the quantity of gas made and sold, also to the number of consumers and public lamps. The quantity of gas made is shown by the station meter, which is usually kept in accurate working order, and, therefore, this return will be correct to a fraction. The gas sold includes not only the aggregate indications of the consumers' meters, but also various quantities sold by contract, without meters, for public lighting and other purposes. Gas engineers naturally like to show as small a leakage account as possible, and, therefore, are not likely to underestimate the bulk in the case of gas that is sold without measurement; and so the returns for gas sold may be regarded as certainly not under the mark.

It is not possible to deal in this letter with the whole of the varied information included under the 24 headings comprised in the returns. So I may remark in passing, that they are published at a low price—about half a dollar for the two, and are readily obtainable by those who may desire to examine this interesting subject in detail. The summary shows that there is in the United Kingdom about 260 million dollars actually invested in the gas industry, and that the plant represented by that sum turns out nearly 85 thousand millions cubic feet of gas per annum, requiring for its production alone 8½ millions tons of coal. And this quantity of gas is distributed, by means of 19,000 miles of mains, to 2,100,000 consumers, and more than 400,000 public lamps.

But the most interesting feature of the papers is the comparative tables, in which the totals for the last four years are given. Without exception all the items show an increase year by year. It is not a large one, but it is steady and well sustained. As an example, the quantity of gas made may be cited, which in the year 1882 amounted to just over 73 thousand million cubic feet, but which, as above remarked, now approaches to 85 thousand million. This is satisfactory as showing the steady increase in our business, which is due not so much to the increase of consumers as to the introduction of stoves and other appliances, which have had the effect of increasing the average consumption per consumer. The number of consumers in 1882 was about 1,970,000, and this compared with the figure above given for 1885 shows an increase of 6 to 7 per cent. But the increase in consumption of gas is more

than double, being 15 or 16 per cent. It may be well to remark before leaving this subject that although nearly all gas undertakings making more than, let us say, 5,000,000 cubic feet per annum, apply to Parliament for a special act, and so become authorized gas undertakings, there are a large number of smaller ones scattered abroad throughout the country whose income is not large enough to warrant the legal and other expenses connected with the obtaining of an act of Parliament. In Scotland, and especially in Ireland, there are several gas companies whose operations considerably exceed the above limit who have not thought it necessary to acquire Parliamentary protection. Where all the large gas consumers are shareholders in the undertaking, for instance, there is no fear of competition coming in; and if any attempt is made to force a high price upon small customers, the undertaking suffers by reason of the restricted demand. So there are often circumstances which bind together the interests of all parties concerned, and thus render legal enactments unnecessary. Therefore the actual quantity of gas manufactured in the United Kingdom is considerably more than that shown by the aggregate of the authorized returns as above mentioned.

Having more than once had occasion to remark upon the nonsense on the subject of gas supply and consumption that has appeared in our daily press, I have pleasure in calling attention to a really good common sense article on the subject of "Economical Gas Burning," that came out in a recent issue of one of our leading newspapers, the *Daily News*. It commences by remarking that now is the time, when the dark and cold weather is coming on, to think about economical gas consumption. But it usually happens that the gas bill for the quarter ending Sept. 30th is a very light one, and is paid without a thought; so that matters go on unheeded until the account for the quarter ended December 31st is presented, which will be some time in January. This, of course, as it covers the darkest days, is a heavy one, and the result is that the consumer begins to talk about economizing gas at a time when the heaviest consumption is over and gone. The writer goes on to remark that though unexplainably high gas bills are sometimes met with, such cases are rare, and that a little intelligent management will materially affect the cost of gas in almost any household; and when bills are abnormally high it will generally be found that the phenomena is due to a want of intelligent supervision, or of ignorance as to the best way of obtaining a maximum of light with a minimum of gas. The principles necessary for economical consumption of gas, such as the effect of pressure, the necessity for burners of suitable size and make, proper supply of air, etc., are set forth in plain language. And the consumer is recommended to select good burners, and see to the regulation of the pressure. He is also very pertinently reminded that "the economy secured by the best of appliances may easily be neutralized by an extravagant employment of gas lights in out-of-the-way and unfrequented corners of a house." It is remarked that consumers esteem a fall of 2½ or 5 per cent. in the price of gas a matter of great importance, and yet they often defraud themselves of 10 to 20 per cent. of the value of the gas by the use of unsuitable fittings and burners. The article is so cleverly and pithily written that an abstract fails to do it justice. It must be read in its entirety in order to appreciate all its good points.

The electric light is gaining a certain degree of notoriety, although the same may not take the direction desired by its promoters. The chairman of a suburban gas company remarked, at a meeting held some years ago, when the extravagant claims in behalf of the new light were in full bloom, that it had been asserted that the electric light was like the sun, and he would admit that such was the case. For the sun was frequently obscured by clouds, and it set and went out every night; and the electric light was also frequently obscured, and set and went out. The truth of the simile is still maintained. Only a few days since the occupants of the reading room at the British Museum had an unpleasant illustration. This is a large room with accommodation for a considerable number of readers, in connection with the well-known library, and as it is open free, it is usually well patronized. I have heard that a considerable number of *original* inventions first came to light in this room, but cannot say if such is the case. On the evening in question the librarian suddenly called for the prompt return of all books, as the electric light was going out, at the same time advising the readers to follow its example. As no gas or candles were at hand, and the reading desks and chairs offer some impediment to an easy exit in the dark, his advice was promptly acted upon. Evidently the electric light cannot be trusted to stand by itself yet. In another case, a well-known concert hall was lighted by gas and electricity together, and the latter suddenly went off duty in the middle of the evening. Fortunately the gas is always on hand to take the place of its erratic rival when necessary. An amusing case happened at a town in France recently. A large theater had been fitted up with electric lights, to the displacement of gas, which had formerly been used. As usual, the gas fittings had been left intact ready for any emergency, but the manager of the gas works, finding that the uncertainty of the demand would cause him some inconvenience, as he would never know whether the theater would be lighted by gas or not, sent down *sub rosa*, and introduced a short length of small pipe on the supply service. For some nights this was unsuspected, as

sufficient gas passed to keep up the supply all over the house when the lights were turned down low. But one evening, in the middle of the performance, the electric light failed *in toto*, and a rush was made to turn on the gas. This was duly done, but little more than a glimmer could be obtained, so a messenger was promptly despatched to the gas works to ask that more gas might be turned on. The discomfited proprietor of the theater received a message in reply to the effect that the gas works people had only sufficient gas for their regular customers; so there was nothing to do but to bring the entertainment to a premature close.

Mr. C. C. Carpenter, of the Vauxhall Gas Works, London, recently read a paper, at the meeting of the Southern District Association of Gas Managers, which affords some valuable information on the subject of gaseous fuel, and which has given rise to an animated discussion in the columns of the *Gas Journal*. Without going into theoretical questions, Mr. Carpenter has given plainly the practical results that he is able to obtain with different kinds of furnaces, and then proceeds to describe an arrangement which he has found to give results as good as any he has yet tried. This new arrangement possesses the important feature that one generator is made to supply gaseous fuel to four separate settings of retorts. The settings are placed on arches as usual in a stage retort house, and the furnace or producer occupies one of these arches, the remainder being left void. So many different views exist upon the subject of generators and regenerators that it requires no inconsiderable amount of courage to set forth any new views upon it, on account of the vast amount of criticism that is sure to be aroused thereby. Although Mr. Carpenter has brought out some hostile remarks, there is generally an agreement that he has made an important advance, not only as regards the heating of retorts, but also in respect to the general application of gaseous fuel.

There has been a big bonfire at one of the Birmingham Gas Works, where a heap of coke 100 yards long by 60 yards wide, and rising from 30 to 60 feet in height, got well alight by some means or other, probably in consequence of carelessness on the part of the stokers in throwing hot coke upon the heap. Immediately on discovery steps were taken to extinguish the fire by means of water and removing the coke, but the combustion continued for nearly a week, it being at last found necessary to call in the fire brigade, who set to work with half a dozen sets of hose at various points. The heat, sulphur and clouds of steam produced by the application of water naturally created great excitement in the neighborhood of the works.

ITEMS OF INTEREST FROM VARIOUS LOCALITIES.

COL. FRED. S. BENSON TO TAKE A TRIP TO EUROPE.—That clever gas man and gallant soldier—Colonel Fred. Benson—who presides with such success over the manufacturing department of the best managed gas company—the Nassau—in the City of Churches, will in a few days entrust his manly spirit and portly frame to the care of one of the ocean greyhounds that will bear him on to old England. Col. Fred. is commissioned by the Nassau folks to examine into the theoretical details and to inspect the practical working of the various forms of regenerative furnace and improved bench construction now in use in Great Britain and on the Continent. May old ocean remember the virtues of mildness during the hours that the voyager will tempt the briny deep, and may the terrors of *mal de mer* never beset him.

ONE DAY'S SENDOUT FROM THE PHILADELPHIA GAS WORKS.—For the 24 hours ended Monday, December 20th, the quantity of gas sent out from the Philadelphia works measured, in round numbers, 13,269,000 cubic feet. The heaviest consumption in 1885 occurred on December 14th, when the footings showed a delivery of 13,021,000 cubic feet. No wonder private enterprise casts longing eyes at the Trust's business.

BATAVIA (OHIO) WOULD LIKE A GAS WORKS.—Batavia seems in a fair way to have a gas works pretty soon, at least Mr. J. O. F. Tatman, a Batavia merchant, says so. He proposes to purchase the plot known as the Jamieson property, which is located on Main street, as a site for the plant. Batavia is the capital of Clermont county, is on the east fork of the Little Miami river, and is 98 miles southwest of Columbus. Population about 3,000.

NAMED AS SUPERINTENDENT.—Mr. H. Porter has been appointed to the Superintendency of the Hudson (N. Y.) Gas Company's plant. Mr. E. Gifford, Jr., formerly acted as Treasurer, Secretary, and Superintendent of the Company, and we expect, like the experience of many other gas companies, the details of the three departments proved too onerous at last for one man's care. Mr. Porter has been in the employ of the Hudson Company for some years, and it is greatly to the credit of the proprietors that his fidelity to them is now rewarded. Mugwumpism, if Mr. Dana of the *Sun* will pardon us for the seeming breach of copyright committed, of the Hudson type is to be commended; and, as a rule, proprietors of gas works are mugwumps in so far as the latter means the retention or promotion in

their service of one who has served them faithfully and well. Not that we mean to intimate that Mr. Dana does not follow a similar rule in the *Sun* establishment, within which everyone and everything—not even excepting the cat—is treated in accordance with the mandate, "*Fiat justitia, ruat coelum!*"

A WORD OR TWO FROM GENEVA, N. Y.—Geneva, N. Y., famed for years for its beauty, rests as placidly and contentedly as ever on the border of Seneca Lake; but the progress of time has brought other changes, or those which mark the development and growth of a busy mart, and its people are duly and properly thankful for the multiplicity of signs which betoken the conquering tread of commerce. Perhaps Geneva's gas men are about as thankful as any other class of business devotees who reside within that city's classic precincts, for increasing commerce demands more light in order that commercial wares may be properly displayed, etc. Now, it is not so many years ago when the plant of the Geneva Gas Light Company, which consisted of one bench of small threes, running at irregular intervals in the manufacture of a wood gas subsequently enriched with naphtha, was ample enough to satisfactorily supply the quantity and quality of illumination demanded by the gas consumers of the place. The "bed of threes" of ancient times, however, had to give place to two benches of three clay retorts each, and coal was called upon to supplant the wood and naphtha material of the ante bellum days. The new equipment answered passably (or less) well until the season of 1885, but finally the management was compelled to admit that Superintendent S. S. Graves' demand for increased facilities could be no longer staved off. As a consequence he was empowered to go ahead with his plans, and the completion of these in time to meet the winter output of 1886-7 cut short his summer vacation—a privation most willingly submitted. The result of the summer campaign may be thus summed up: Two benches of fours were installed; a new exhauster put in; purifying capacity enlarged; and those other minor items, whose aggregate goes so far toward "making things run easy," were attended to. Like a prudent commander, having arranged everything needful for future possible contingencies, Supt. Graves determined to make a bold attack on the enemy's front—enemy meaning those who were partial to kerosene oil—and, having convinced his directors of the "powerfulness" of that particular sort of ammunition, swooped down upon them—the enemy—with the battle-cry of lower "charges" for gas. The usual result followed, which is that capitulation after capitulation was announced, and the directors of the company wondered and chorused, "Why did we not charge less before?" In fact, we might add on our account that the present rate (\$2.50 per thousand cubic feet, former rate \$3) appears to be rather high, and will in the near future amply stand a further cut. However, and since we are told, "All things come to those who wait," perhaps Supt. Graves' retort house figures for the dark days of current winter season, when placed alongside of like calculations concealed by the ghost of the past, will unfold a tale tending to convince his employers that, in the gas business anyway, money comes soonest to those who act quickly in the matter of adjusting their rates to a schedule based on the principle of enunciating to their consumers that a tariff for fair revenue only is the object in view. Still, the Geneva gas men have made a start, which is the prime reason that leads us to think they will be in at the finish, ready to repeat a "run" certain to end profitably.

A SAMPLE OF ENGLISH GAS RATES.—Gas consumers in this country, particularly when those resident in the smaller towns "rise in their might" to confound the proprietors of the local gas undertaking, use as their first, middle, and final knock-down argument the assertion that gas prices in England are by far lower than those charged in similar places in the United States. This, like the rest of their "clinchers," is wide of the mark, in proof whereof we submit the following important concession lately promulgated by a Mr. Geo. Weller, who, we presume, from the tenor of the announcement, is owner of the St. Ives Gas Light Company. There is some doubt in this case whether St. Ives, of Cornwall, near Penzance, or the place of same name, on the Ouse river, near Huntingdon, is referred to. If the former, a population close on to 7,000 is supplied; but if the latter, the lighting needs of some 3,300 people is catered to. However, we incline to the view that the Cornwall district is the one in which Mr. Weller operates, and from the tables furnished in Hastings' directory of English gas companies, we find the capital stock of that Company is put at £10,000. The reader can draw his own deductions from the card published by Mr. Weller, which reads: "I beg to inform you that I have just made a cheap rate for gas used in this town for cooking and heating—viz., 5s. (\$1.25) per thousand cubic feet, for which a separate meter must be provided. Gas used for lighting is 6s. 8d. (\$1.66) per thousand cubic feet, which price has been charged for many years. You will, therefore, see that I have made a good reduction, and if I am supported in this by the consumers generally—so as to increase the consumption—I am prepared to make a further substantial reduction in price, but to do this I must have a larger consumption." We believe that meter rent is also charged; and if so we fail to note why many of the gas companies in the United States

similarly situated, in respect of facilities for receiving and purchasing supplies, cost of same, etc., to Mr. Weller's Cornwall gas undertaking, are not doing much better in the matter of their charges to consumers than is the case with him. Again, it may be well to understand that the illuminating power of the Cornwall product probably does not exceed 15 candles.

AT REST.—We chronicle, with sorrow, the demise of Mr. Theodore B. Stephens, who for years had been the business manager of the Tarrytown (N. Y.) Gas Light Company. The sad event occurred on Tuesday, December 21st, 1886, and interment of the remains was made from the Washington street Methodist Episcopal Church, Tarrytown, on the following Friday. Having known the deceased for many years, we can say from that knowledge that an upright man and faithful friend has been taken from us.

BRECKENRIDGE CANNEL GOES TO LIVERPOOL.—A despatch from Messrs. Perkins & Co., dated December 23d, 1886, informs us that the steamer Cairn Marth had just been chartered to carry 2,000 tons of Kentucky's famous cannell from New Orleans, La., to Liverpool, England. The agreed-upon terms of charter placed the freight consideration at 25 shillings per ton, and the cargo awaits the vessel at New Orleans. Our eyes! Think of sending American cannell to England—a sort of Christmas offering, as it were.

TO PIPE NATURAL GAS TO ST. LOUIS, MO.—A line from St. Louis informs us that a project is on foot to supply natural gas to the St. Louis mill owners and foundrymen, the scheme being to pipe the gas from Edwardsville, Ill., a point about 30 miles distant from St. Louis. It is said that the pressure at mouth of wells from which the supply is to be derived equals 300 pounds to the square inch, and that the volume is sufficient to ensure a plentiful supply. The expense of the pipe line has been raised by subscription, from various St. Louis manufacturers, in amounts ranging between \$50 and \$1,000. Some of the contributors are not very enthusiastic as to ultimate success, while others are confident about it. The upshot will be awaited with interest; but if the facts, in the matter of pressure and volume, have not been overstated the scheme ought to equal the expectations of the most sanguine of its projectors.

A RESOLUTION WITH AN "IF."—The Greenfield (Mass.) Town Council evidently wants electricity, but if the following is a fair transcript of the resolution passed by that progressive body on date of Dec. 20th, the Greenfielders are still a trifle doubtful about the cost. The resolution in substance is said to have been this: "*Resolved*, That a contract be entered into with a responsible company to light the city by electricity, until April 1st, 1890, whenever better lighting can be secured at no greater cost than that paid for the present gas service." Somewhat misty, we hear said, and truthfully. According to our information the present number of public lamps in Greenfield does not exceed 60.

A LETTER FROM A WASHINGTON TERRITORY GAS MAN.—Mr. Robert Bruce, Secretary of the Olympia Gas Company, under date of December 17, 1886, forwarded the following quaint letter: "Mr. Editor—The city of Olympia is located on the headwaters of Puget Sound, Wash. Ter., and is a really beautiful place, albeit it possesses a population of considerably under 3,000 souls. You may judge as to its climate when I say that at time of writing the grass is green and growing flowers are plentiful. We have a 'duck pond' close by, some hundreds of miles in circumference, which affords feeding quarters and a native element for unlimited numbers of wild fowl and edible fish of the choicest varieties; and the timber that lines its banks grows to such a height that one has to look twice ere he discovers the foliage at its top. As for fruits and vegetables, I refer you to some of the samples contributed from here to the late New Orleans Exhibition, amongst which was a specimen of a wild gooseberry bush—the inevitable bush so dear to the hearts of those who boast of the glories of California vegetation—that had reached a height of 22 feet! Despite all these crowning advantages, the great drawback to the material and rapid advance of Olympia's prosperity is her stretch of mud flats. One mile from her wharves the greatest ship that ever was built could ride at anchor in one of the finest harbors in the world; but that fatal mile does all the mischief. At high tide there is a depth of but 12 feet of water at the city's wharves; yet there is likelihood all this will be changed, for the city authorities have entered into a contract which calls for the excavation of a fairly wide channel connection to deep water. Some work has been done on this contract, and while the same was in progress an average distance of 110 feet per diem was made. Owing to one cause or another the prosecution of the task was deferred to the spring of '87. With a channel to deep water, if Eastern capitalists cannot perceive an opening for judicious and profitable investment of money, then they must be nothing short of blind. Anyone may easily post himself as to the natural resources of our Territory, and in the rush sure to come it might be well to remember that the first on hand will have the 'pick of the basket.' There is some talk about the U. P. Rail-

road making connection here; and they had better come while the field is open. Now as to the local Gas Company. We are barely paying expenses at present, for times are extremely dull just now. The Company's plant is in pretty good shape, and is valued at \$50,000. The list of officers comprises A. A. Phillips, President; Alex. Farquhar, Treasurer, the undersigned being Manager and Secretary. In order to encourage a more liberal use of gas we, on November 1, 1885, reduced selling rates from \$4 to \$3.50 per thousand cubic feet; again, a twelvemonth afterward, the price was reduced to \$3, and I can truthfully say that every effort was made to please our people. However, all the encouragement we have received thus far is a total of 70 private consumers, and a contract with the city for 13 public lamps. We are not discouraged, despite the lack of recompense so far obtained, and are far from disposed to give up the fight."

Let us hope that the channel will soon be an accomplished fact, and that the Olympia gas men will speedily receive the recognition due their pluck.

GAS FOR CHRISTMAS DAY.—The proprietors of the Sanford gas works expected to be able to supply gas on Christmas day. A nice sort of present.

GAS COMPETITION AT FINDLAY, OHIO.—The *Cleveland Leader* says that since the establishment of the city gas works at Findlay the old Findlay Gas Light Company has reduced the price of gas (natural) to 25 cents per month per stove, and will furnish gas to the churches free. Last winter, it is said, the price was \$1.50 per stove. The city first reduced to 50 cents per stove, and the old company followed with the present cut.

GAS FOR THE STREET LAMPS OF KANKAKEE, ILLS.—Two years ago the Sun Vapor Light Company, of Canton, Ohio, secured the contract for lighting the public lamps of Kankakee, Ills., and although it is said they performed the work in accordance with their agreement, the residents did not fancy the general results secured. Last December the contract expired, and hereafter the Kankakee Gas Company will do the work. The Sun Company received \$15 per post per annum for the superseded gasoline lamps, but the Kankakee gas folks have now agreed to supply gas light at an annual charge of \$14.50 per post, they to light and extinguish. A moon table is followed, of course. Something less than 60 gas lamps are located on the Company's mains, and recourse must still be had to the festive gasoline in situations not yet reached—to borrow a phrase from the language of that great amateur gas engineer, who strutted his brief but burning hour, aglow with youth, beauty and innocence, before the Senate Committee that investigated the gas supply, etc., of New York city, Mr. Bottsford—by the arteries (gas pipes they are sometimes called) of the gas men. The oil lamps number 70, and will cost \$12.50 per annum each.

THE CINCINNATI GAS ORDINANCE PASSED.—At a meeting of the Cincinnati (O.) City Council, held December 17th, the ordinance recommended by joint committee (noted in our last issue), by which the Cincinnati Gas Company is instructed not to charge over \$1.25 per thousand cubic feet for gas supplied to its customers, was endorsed by a vote of 33 for to 10 against. The ordinance is to remain in force for ten years.

PUBLIC LIGHTING AT BURLINGTON, IOWA.—The gas committee of the Burlington City Council advertises for bids for lighting that city's streets. The Burlington contract is made from year to year.

THE EDISON COMPANY, OF AURORA, ILLS.—At a meeting for organization of the Aurora Edison Light Company, Mr. F. O. White was chosen president; S. J. Ricker, vice-president; A. M. Brown, secretary and treasurer. The aforementioned, and Messrs. E. H. Louderback, F. S. Gorton, T. Phillips and J. N. Clark, comprise the directors. At the meeting subscription books were opened, and the public were invited to take chances on the future of the shares.

A GAS COMPANY'S WATER BILL.—The Chicago (Ills.) Gas Light and Coke Company had some trouble with the municipality in regard to the payment of the water tax bill, handed in by the latter, for the Company's water supply for the six months ended November 29th. According to the statement rendered it appears the Company used 2,520,481 gallons water in the six months, and the charge therefor was based on a tariff of eight cents per thousand gallons, or a total of \$204. The Company refused to settle on the proposed basis, and showed that last year water commissioner Cregeir had previously ruled that six cents was a sufficient charge. On proof of that statement the Company submitted its receipted water tax bill, for the six months ended April 1st, 1886, which showed that during the specified period 2,901,723 gallons of water were consumed, and but \$174 had been paid therefor. The Company's case was so clearly proved that the present water commissioner, Mr. Purdy, decided the city could only charge at the rate of six cents, as formerly. Of course, either rate cannot be looked upon as excessive, and the actual money difference involved was small, but right is right. Brother Watkins, anyhow, never did like to permit the Lake City authorities

to get the better of him; and, come to think of it, they haven't much to brag over in that respect in so far as the record goes.

A COMPANY THAT PROPOSES TO HAVE MANY IRONS IN THE FIRE.—Early last December Messrs. J. H. Howe, H. B. Hinsdale, and E. Simmons filed articles incorporating the American Water Supply Company, of Kenosha, Wis. The incorporators propose "to furnish gas, electric light, and power to the public." 'Tis a bad thing to bite off more than the molars, incisors, etc., can comfortably handle. The "men at the helm" have fixed the capital stock at \$90,000.

MORE SPORT FOR CHICAGO, ILLS.—Messrs. G. N. Ackley, B. F. Weber and G. H. Carver have placed themselves on record as the legal progenitors of the Cook County Mutual Gas Company, of Chicago, and the aforesaid declare their intention that such corporation is a necessary adjunct, or one without which the people of Cook County cannot successfully subsist. Subsistence in this case meaning a supply of illuminating gas for lighting, heating and power purposes. The incorporators seem to believe that a capitalization of \$100,000 will be sufficient for the end in view. Others who have prospected in that locality were more ambitious in their announcement of capital amounts; but an equality of fate seems to have been the portion of those who sought contest or conflict with a man who always had the courage of his convictions, and the hardihood to express them—we refer, if the figure was not already made plain, to Mr. Forstall.

SOCORRO (NEW MEXICO) WANTS A GAS COMPANY.—Henry Lockhart, Chairman of the Water and Gas Committee of Socorro, advertises that the "City Council will receive sealed proposals for the gas franchise of the city of Socorro. All bids must specify the length of time desired for the franchise to run, the charges for gas to private consumers, and the charges to the city for street lighting, as well as other necessary matters of detail. The party receiving the award will be required to give a good and sufficient bond, in the sum of \$5,000, to the city of Socorro for the completion of the works within one year. Bids will be received until Monday, January 10th, 1887." Socorro is the capital of a similarly-named county in New Mexico, and is on the west bank of the Rio Grande, at a point about 80 miles south of Albuquerque. From the latest data at hand the population of the place does not exceed 5,000 souls. Flouring mills and silver mines afford the principal industrial occupation of the people. It is a thriving place.

NEW GAS COAL COMPANY.—Pittsburgh capitalists have created a new company for the mining of gas coal. The new corporate enterprise bears the name of the Shaner Gas Coal Company, and is capitalized in \$250,000. Mining operations will be started on a vein about one-half mile distant from Guffey's station—the latter is on the old Pittsburgh & Connellsville Railroad, 24 miles southeast of Pittsburgh. Fifty double houses will be put up for the miners, and the Baltimore and Ohio people will put down a track to connect the mine with Guffey's station.

ELECTION OF OFFICERS.—At the annual election of the Columbia (Pa.) Gas Company, Messrs. H. M. North, J. H. Black, H. F. Bruner, C. E. Graybill, J. A. Myers and M. S. Shuman were selected as a board of managers. Mr. Shuman is the only new member, he having been chosen in place of the late Samuel Truscott. Mr. Samuel Shoch was re-elected President.

AURORA (ILLS.) HAS AN ELECTRIC LIGHTING PLANT.—It is reported that Aurora's (not the one who so mightily pleased the fancy of the artist) electric lighting plant costs the taxpayers about \$5,000 per annum, and in return therefor 72 arcs (low power) do duty as illuminants.

A SAD BLOW.—It gives us sorrow to chronicle the death of Mrs. Alice W. Slater, the late wife of Mr. A. B. Slater, Jr., and daughter-in-law of Mr. A. B. Slater, of the Providence Gas Light Company, who departed this life on December 22. Deceased, who was but in her 23d year, gave abundant promise of a glorious womanhood, yet it was not to be, after all. The fraternity will sympathize deeply with the stricken husband and his sorrowing relatives.

Notes from the West.

By RETORT.

DECEMBER 24th, 1886.

With the closing of the year one naturally turns a retrospective glance to sum up the present condition of his business in contrast with the condition of the same one year ago; and in all lines of business the beginning of a new year calls for a serious and impartial survey of the past, as well as a renewal of effort for the future. Undoubtedly no other year in the history of gas lighting has encircled so much of important history as that of 1886. The year stands without parallel in activity, and is unapproached in the matter of progress. In fact, as great progress has been made in some directions as

had been made in a decade before, and, taken all in all, it was without doubt a thoroughly remarkable year. No business that is freely advertised can remain dormant, and no business has been more thoroughly advertised in many ways during the year than that of ours.

The discovery and development of natural gas have been of such vast importance as to not only stimulate its immediate locality, but the influence has been felt all over our broad land. It is an educator, superior to all others, in the matter of teaching the use of gas for fuel and mechanical purposes, and will do continued good in that direction. The simple fact that all the people of the town or city of ——— perform their heating and cooking with gaseous fuel is a convincing argument that, the cost being satisfactory, the same can be as successfully done elsewhere; and gas companies now have ten inquiries regarding gas stoves where they had but one the season before. Of course, the reductions in price, so nearly universal, acted as the principal promoter of the sale of gas as a fuel; but unquestionably next in importance to that factor has been the intelligence disseminated through the press and otherwise in connection with the natural product, as to the fact of its economy and cleanliness, not to speak of its labor-saving features. When the public generally learns the true proportion of the calorific properties as thoroughly as it now knows the difference in cost per thousand feet between natural and artificial gas, gas stoves will be in still greater demand.

Another wonderful stimulus, and equally valuable advertiser of gas interests, is the electric light. This light has pushed its way into prominence with wonderful rapidity during the year, and has been the means of infusing new life and activity into many a gas company's management, and, in equal measure, promoted gas sales. The electric light, upon its introduction into a community, enjoys unusually favorable facilities for business in its role of a competitor to some so-called monopoly of long standing, and usually plays its cards with tact and skill; but while it picks up much of the valuable business of its competitor, yet it opens so much new business for its seeming rival (the gas company) that its long dreaded advent is apt to be considered with too little caution or wisdom. The important phase of the electric light question is not so much what it now is as what it is to be. It is proverbially difficult to introduce into our retort house improvements of a labor-saving character, and we wonder at the clannish, narrow views of our stokers; but are we not, as gas managers, prone to consider in much the same way the advent of the electric light as a competitor? The question whether it is best for gas companies to operate a combined plant of electric and gas lighting is an alarmingly unsettled one, and it weakens one's faith in those we regard as men of pronounced ability in gas matters to hear them at one time poo-pooing the value and stability of a light, and within a twelvemonth as strongly advocating its adoption. It is very true that, in large measure, these questions must arise and be duly considered under the surrounding circumstances; but in matters of such general importance, and embracing so much financially, it does not seem possible to make sudden and complete conversions. I have often thought that in favorable circumstances, if there is a demand for electric or any other form of artificial illumination, the local gas company is the one to supply it; yet so very much is comprehended in the local surroundings that it is manifestly impossible for any rule to fit any given number of cases.

However this may be, the electric light has knocked at the councilmanic doors of most of our Western cities, and, as a rule, been admitted. A prominent gas man of liberal views and large information is reported to have said recently, "I think the future of electricity is more in the line of motive power than in that of light." And immediately upon the heels of this we read of the displacing of a 17-horse power gas engine by a 6-horse power electric motor, which latter receives its power through an ordinary wire from a light station. The further information is given that a 50-horse power dynamo will operate twelve 6-horse power motors, each capable of displacing an 18-horse power gas engine. In other words, the initial power being 50-horse, when subdivided and distributed through "So and So's motor" it gives out not 50 but 216-horse power. Evidently the fixed laws of mechanics and electricity are severely strained in the transmission. Admitting that nothing else in the annals of mechanical invention is more wonderful than the electric motor, nevertheless the motor is not yet discovered that can "lift itself by its suspenders," so to speak. At the same time, the electric motor, if not now, will unquestionably at no very distant time be a success, and will then be pushed for its share of the mechanical business.

Our weakest point in the competition with electricity is our street lighting. While we can do the public lighting far better and for much less money with gas, yet, with a hue and cry about public enterprise, a street lighting contract is awarded the electric promoters, and thus for a given number of years they are in possession. As a plain business proposition, they seek to attract business from our consumers in order to make their own business more profitable. Hence their energy and activity. After the plant is put in and their light turned on, it is a very small matter whether or not the illumination is as satisfactory as that from gas. It is pleasant to know that our illuminator is preferred; but the fact remains that they are fur-

nishing the light and drawing the pay for the same. Now, it is obvious that if we desire to obtain and retain this business, and to put in a plant for the purpose, it should be done *before* the field is occupied.

A well-known gas man, who holds a controlling interest in several works, has adopted a policy of submitting three or more separate bids to his various constituencies, offering to light the city with gas alone, with electricity alone, or with gas and electricity combined; and his bids are laid before the authorities in ample time for him to erect his plant if the electric light is, in whole or in part, adopted. Why is not this, where it can be done, a wise idea?

IN FAVOR OF PLAINTIFF.—In the suit for preliminary injunction, brought by the Albo-Carbon Light Company, of Newark, N. J., in the United States Circuit Court for the Chicago (Ills.) district, to restrain Newman A. Ransom from infringing letters patent owned by plaintiff, Judge Gresham granted the prayer of the petitioner.

Correspondence

[The JOURNAL is not responsible for the opinions expressed by correspondents.]

Mr. Emerson McMillin Refers to Mr. Frederic Egner's "Chapter on Practical Gas Making."

COLUMBUS, OHIO, Dec. 21, 1886.

To the Editor AMERICAN GAS LIGHT JOURNAL:

I have read Frederic Egner's communication, contained in the last issue of the JOURNAL, with great interest; and if any gas engineer in this country may be properly styled an original investigator Mr. Egner is entitled to that distinction. His productions, as published from time to time in your JOURNAL, always contain something fresh, and afford wholesome food for thought.

While the table of results obtained, given by him to us in his last paper, are instructive as a whole, I am most impressed by the last paragraph of his communication. He tells us it is possible to get 6 cubic feet of 22-candle gas out of a pound of coal that, treated in the old way, yields but 4.25 cubic feet of 14-candle gas. Indeed, he claims to have obtained even better results than these. That is a bold statement; but let skeptics pause and think before saying, "Impossible." I do not know how Mr. Egner obtained those results, and he does not tell us whether, from a commercial standpoint, it would *pay* to get such results. The writer had a system presented to his notice, a few months ago, by which the yield could be run up to 6.5 or 7 cubic feet of 20-candle gas, but it was done at the sacrifice of all the tar and ammonia water, and with a largely increased consumption of coke. I believe the claims of the inventor could be verified in practice, but when the claims were analyzed and reduced to cold figures, it became evident that the gain by the use of the process would not equal the loss.

I cannot say, of my own knowledge, that the claims of Mr. Egner can be demonstrated; but I do say, however, that it is possible, with Youghiogeny or Kanawha gas coal, to obtain as large a yield per pound of material, as large quantity per retort, and as high candle power, without the use of an enricher, as Mr. Egner obtains when using 4.8 gallons of oil per ton of coal. Just what temperature of retorts will produce these results, and how to keep the heats at that point, I am not yet prepared to say. That it is possible sometimes to increase the yield, and at the same time increase the candle power, may be theoretically demonstrated in the following manner: C₂H₄ (one volume of ethylene) broken up, equals C₂H₂ (one volume of acetylene), plus H₂ (one volume of hydrogen). Here we have two volumes where but one existed, and the acetylene is said to have four times the lighting power of ethylene. Again, at extremely high heats the benzol of the tar will be decomposed, yielding hydrogen, and probably acetylene. This adds greatly to the quantity, and, of course, some to the quality; for had the benzol not been decomposed it would have been absorbed and removed from the gas by the tar.

Again, we may get acetylene with increased total volume from the decomposition of marsh gas, thus: 2C₂H₆ equals C₂H₂ plus 4H₂; or, beginning with two volumes we end with five. Ordinarily by increasing our heats we increase the volume, but decrease illuminating power by forming hydrocarbon compounds that will not remain gaseous. For instance, marsh gas may be broken up thus: 10C₂H₆ equals C₁₀H₂ plus 16H₂; but this gives us naphthaline, which had best not be produced. Of course, we cannot do more than surmise whether these combinations occur direct, or whether they pass through intermediate stages, forming complex compounds, probably of which we have no knowledge. All this, however, is mere theorizing; but the fact remains that 5.25 to 5.50 cubic feet of gas can be made, under proper conditions, out of Youghiogeny or Kanawha gas coal.

Trusting that Mr. Egner will not only continue his investigations, but that he will continue to give the fraternity the benefit of the knowledge thus gained, I am

Yours truly,

EMERSON McMILLIN,

The Market for Gas Securities.

There is nothing of interest to report in connection with the market for city gas shares. Fluctuations in Consolidated quotations have been confined to fractions either way, and it is noteworthy that while the general market for railway shares broke many points, during the semi-panic hours of a fortnight or so ago, Consolidated yielded but slightly. Equitable is steady, and its managers have declared a dividend of 2 per cent., payable Jan. 15. Mutual ought to be a purchase at the offering price of 102. The Brooklyn situation remains unchanged, but it may be asserted, and safely, come what will, that old Brooklyn gas is at bed rock. The Citizens Company paid a semi-annual dividend of 3 per cent. on Jan. 1st. Metropolitan Company an equal return on same date. The Fulton Municipal dividend of 3 per cent. is payable on Jan. 15. In out-of-town shares Laclede, of St. Louis, Mo., presents a sharp advance, 112 being freely bid, while holders ask 115. On Jan. 1st the Providence (R. I.) folks paid a dividend of \$1 per share, and the New Orleans (La.) Company, on Jan. 15th, disburses a dividend of \$3 per share—this latter being at the rate of 6 per cent. per annum.

Gas Stocks.

Quotations by Geo. W. Close, Broker and Dealer in Gas Stocks,

16 WALL ST., NEW YORK CITY.

JANUARY 3.

All communications will receive particular attention.

The following quotations are based on the par value of \$100 per share.

	Capital.	Par.	Bid	Asked
Consolidated.....	\$35,430,000	100	78	78½
Central.....	440,000	50	—	—
“ Scrip.....	220,000	—	47	57
Equitable.....	2,000,000	100	113	—
“ Bonds.....	1,000,000	—	113	115
Harlem, Bonds.....	170,000	—	—	—
Metropolitan, Bonds....	658,000	—	110	113
Mutual.....	3,500,000	100	100	102
“ Bonds.....	1,500,000	1000	100	—
Municipal, Bonds.....	750,000	—	—	—
Northern.....	125,000	50	36	—
“ Scrip.....	108,000	—	—	—
Yonkers.....	—	50	51	55
Richmond Co., S. I.	300,000	50	50	—
“ Bonds.....	40,000	—	—	—
Gas Co's of Brooklyn.				
Brooklyn.....	2,000,000	25	101	103
Citizens.....	1,200,000	20	56	58x
“ S. F. Bonds....	320,000	1000	—	105
Fulton Municipal.....	3,000,000	100	130	133
“ Bonds....	300,000	—	—	105
Peoples.....	1,000,000	10	48	51
“ Bonds.....	290,000	—	—	103
“ “.....	250,000	—	—	102
Metropolitan.....	1,000,000	100	72	75x
Nassau.....	1,000,000	25	—	100
“ Cfts.....	700,000	1000	—	101
Williamsburgh.....	1,000,000	50	118	120
“ Bonds... ..	1,000,000	—	—	111
Out of Town Gas Companies.				
Buffalo Mutual, N. Y... ..	750,000	100	90	95
“ Bonds... ..	200,000	1000	95	100
Citizens, Newark.....	918,000	50	130	138
“ “ Bonds.	124,000	—	105	110

FOR SALE,

One Station Meter, 5 ft. by 5 ft., in perfect order.
 One 12-in. Station Governor.
 Six Sections of Hydraulic Main, 19 in. by 22 in., for benches of sixes.
 Also, Mouthpieces and Stand, Bridge, and Dip Pipes for 6 benches of sixes.

All the above in good condition. Apply to

658-6t NEWPORT GAS LT. CO., Newport, R. I.

Superintendent's Position Desired

By a practical man of twenty-five years' experience in the manufacture and distribution of coal and water gas. Satisfactory references given. Address

646-tf "ENGINEER," care this Office.

ALBO-CARBON FIXTURES FOR SALE.

Three 12-Burner, Two 8-Burner, and Fourteen 6-Burner Clusters.

All in good order, having been used but six months. Will be sold cheap. For particulars communicate with

E. G. PRATT, Supt. N. Attleboro Gas Lt. Co., North Attleboro Mass 660-2t

FOR SALE,

Ten No. 2 Siemens Regenerative Gas Lamps, With Factory Fixtures and Reflectors complete and in order. Only used three or four months. Will be sold cheap. DANVILLE NAIL AND MFG. CO., Danville, Pa.

FOR SALE,

Gas Works

IN A GROWING WESTERN CITY.

Reason for selling, owner's inability to give his attention to the business. Address

655-8 P. O. Box 438, GREEN BAY, WIS.

WM. GARDNER,

Gas Engineer,

Lewis Block, Room 20, Pittsburgh, Pa.

Those who intend to make alterations in existing gas plants, or who contemplate the erection of new works, will find it to their interest to open correspondence with the above. Plans made and estimates furnished.

ENGLISH "Journal of Gas Lighting."

Issued weekly. New volume commences Jan. 1, 1887. Price, \$7 per annum. Subscriptions taken by

CHARLES NETTLETON, Agent for U. S., No. 115 BROADWAY, N. Y. CITY.

JARVIS ENGINEERING CO.,

61 Oliver St., Boston, Mass.

CONTRACTORS FOR ERECTING

COMPLETE STEAM OUTFITS FOR ELECTRIC LIGHTING STATIONS.

Steel Boilers set with Jarvis Pat. Boiler Setting,

To burn COKE SCREENINGS for Fuel.

ARMINGTON & SIMS CO. ENGINES,

Belting direct to Dynamos, without using Shafting.

SEND FOR CIRCULARS.

MITCHELL, VANCE & CO.,

MANUFACTURERS OF

Chandeliers

and every description of

GAS FIXTURES.

Also manufacturers of Fine Gilt Bronzes and Marble Clocks, warranted best time-keepers. Mantel Ornaments, etc.

Salesrooms, 836 Broadway, N. Y.

Special Designs furnished for Gas Fixtures for Churches, Public Halls, Lodges, etc.

Ferric Oxide for Gas Purification.

Ferric Oxide, as ground, screened, and prepared by me for purifying purposes, has now been in use for several years by many of the gas works throughout the country, including Detroit, Chicago, Milwaukee, East Saginaw, Burlington (Iowa), Ann Arbor, etc. It has proved, as I believe, the Most Effective and Economical Agent now in use. I am prepared to furnish the Oxide by the 100 lbs. or in car load lots, and will be pleased to give price f.o.b. cars at Ann Arbor or at place of destination. Address

S. H. DOUGLAS, Prest. Ann Arbor (Mich.) Gas Light Co.

GASHOLDER TANK CONSTRUCTION, ETC.

Gas Companies and others about to erect Gasholders will find it profitable to consult W. C. WHYTE, who for over thirty years has made a specialty of

Holder Tank Excavation and Mason Work.

Fifty tanks now in operation show the sort of work done. Address

W. C. WHYTE, No. 15 Cortlandt St., N. Y. City.

Gregory's Retort Incandescent Gas Lamps.

Manufactured under Patents granted and applied for. Over 20,000 sold in New York and Brooklyn. Over 100,000 sold in the U. S. in one year. It is the only lamp that can compete with Incandescent Electric Light. Gas Companies should see that it is on sale in their city or town. They can be attached to any bracket or fixture. A Complete Revolution in Gas Lighting. The invention of GEO. H. GREGORY, Gas Expert. A pure white light obtained from Gas, which is Superior to Electric Light. All lamps are finished in nickel plate. The construction of all lamps allows the gas to be superheated before passing through the tip, rendering the illuminating properties of the gas incandescent, which causes the Brightest Light ever obtained from Gas. Lamps made in all sizes. Gas Companies should assist in introducing this new lamp, which exceeds all other devices for gas lighting. This Cut represents Office and Bracket Lamp. Price, \$18 per dozen; discount 50 per cent. in half dozen lots or more. Send for Catalogue. Address

GEO. H. GREGORY, Mnfr., 337 Broadway, N. Y.

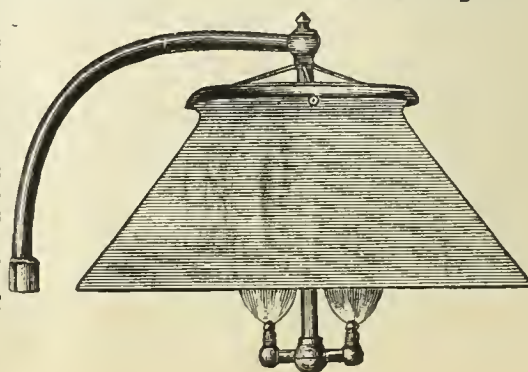

GIBBS PORTLAND CEMENT

Is guaranteed to be the finest English brand, and unsurpassed by any grade imported for making concrete and setting masonry.

Extract of Paper, with tests, read before the American Society of Civil Engineers, sent on application.

HOWARD FLEMING,
Sole Agent for U. S.,
23 Liberty St., New York.

GEROULD'S IMPROVED RETORT CEMENT.

A Cement for patching retorts, putting on mouthpieces, and making up all bench-work joints. This Cement is mixed ready for use. Economic and thorough in its work. Fully warranted to stick. For recommendations and price list address

C. L. GEROULD,
Manchester, N. H.

HOWARD FLEMING,
23 Liberty St., New York.

IMPORTER OF

"BRIDGEND" "DINAS"

Silica FIRE Bricks

FOR COKE OVENS AND GAS WORKS.
PORTLAND AND ROMAN CEMENTS.
Correspondence Invited. Lowest Prices.



STEPHEN A. MORSE, President.
GODFREY REBMANN, Vice-Pres.

M. B. DYOTT,
Superintendent.

EDWIN F. MORSE, Secretary.
CARLTON M. WILLIAMS, Treas.

STANDARD GAS LAMP CO.,

Office, 411 Cherry St. Factory, 1101, 1103 & 1105 Frankford Av.

Philadelphia, Pa.

It is to the interest of Gas Companies and Cities to use Dyott's Patent Champion Lamps, which give double the light with the same consumption of gas, and will save 50 per cent. over others in cost of keeping in repair. Gas Companies and others intending to erect Lamps of any description will do well to communicate with us. Special Drawings furnished and Estimates given on application upon Architects', Engineers' or our Draughtsmen's Plans.

Our Patent System of Instantaneously Lighting Gas (without electricity) for R. R. Depots is unequalled. Our High Candle Power Burner is superior to the Electric Light or any other High Candle Burner. We manufacture every description of Ornamental Lamps.

Illuminating Gas from Natural Gas,

AS MANUFACTURED UNDER THE

McKAY and CRITCHLOW PATENTS

BY THE

AMERICAN GAS IMPROVEMENT COMPANY, LIMITED.

PRINCIPAL OFFICE,
6234 Penn Avenue, Pittsburgh, Pa.

BRANCH OFFICES,
At Titusville and Beaver Falls, Pa.

W. H. DENNISTON, Chairman, Pittsburgh, Pa. }
W. B. ROBERTS, M.D., Titusville, Pa. } OFFICERS & MANAGERS. {
E. T. ROBERTS, Treasurer, Titusville, Pa. } { HUGH MCKAY, London, Ontario.
J. M. CRITCHLOW, Secretary, Beaver Falls, Pa.
JOHN MCKAY, Superintendent, Titusville, Pa.

Should the supply of Natural Gas fail, will sell a plant and right to make Water Gas. Practicable at any Gas Works now in operation, and changes made with trifling cost. New apparatus, complete, with capacity of 50,000 to 500,000 feet per day, \$3,000 to \$10,000.

Guaranteed in Agreement to make Good, Cheap, Fixed Gas, or No Pay. Correspondence solicited.

TRADE MARK.

THE CRYSTAL CARBON LIGHT!

The Latest and Most Improved Gas Light!

ADAPTED FOR PRIVATE RESIDENCES, CHURCHES, THEATERS, STORES, ETC.

These Burners are manufactured on the principle of enriching gas by means of Naphthaline (so-called Crystal Carbon or Albo-Carbon), the invention of the Rev. W. R. Bowditch, F.R.S., of Wakefield, England, who was the original inventor and patentee of this system of gas lighting.

SPECIAL NOTICE.

Many Gas Companies find the Crystal Carbon Light a valuable competitor against the Electric Light. It is ornamental, free from the defects common to all other enriching gas burners, and is as cheap as ordinary gas chandeliers. We sell direct to gas companies, giving them the benefit of agents' discounts.

CARBONCRYSTAL.

(Trade Mark.)

A new and superior preparation for enriching gas used in conjunction with Crystal Carbon or Albo-Carbon gas lights. The preparation is cleaner and better adapted for filling burner vessels than any hitherto produced.

Guaranteed to be chemically pure. Supplied in cans from 10 pounds up.

THIS IS THE CHEAPEST AND PUREST FORM OF ENRICHING MATERIAL.

CRYSTAL CARBON LIGHT CO.,

Main Office, No. 1018 Chestnut Street, Philadelphia, Pa.

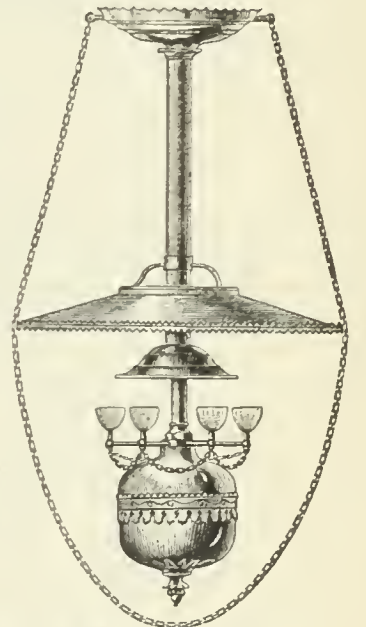

TO ALL WHOM IT MAY CONCERN.

Notice is hereby given that a suit is now pending in the U. S. Circuit Court for the Northern District of Illinois against the Chicago Gas Apparatus Manufacturing Company and Newman A. Ransom, for infringing our rights under Letters Patent of the United States No. 247,925, dated October 4th, 1881, and No. 333,862, dated January 5th, 1886; and that a similar suit for like infringement has been instituted against W. S. Horry (trading as the Crystal Carbon Light Company), Arthur Kitson (trading as Kitson & Co.), and others, in the U. S. Circuit Court for the Eastern District of Pennsylvania. All persons in anywise infringing upon our rights under said Letters Patent will be prosecuted by us upon our obtaining proof of such infringement.

WALTER J. KIDD, General Manager.

THE ALBO-CARBON LIGHT COMPANY, - - NEWARK, N. J.

SOLE MANUFACTURERS FOR THE UNITED STATES

F. J. DAVIS & J. R. FARNUM,

TRUSTEES AND AGENTS FOR THE

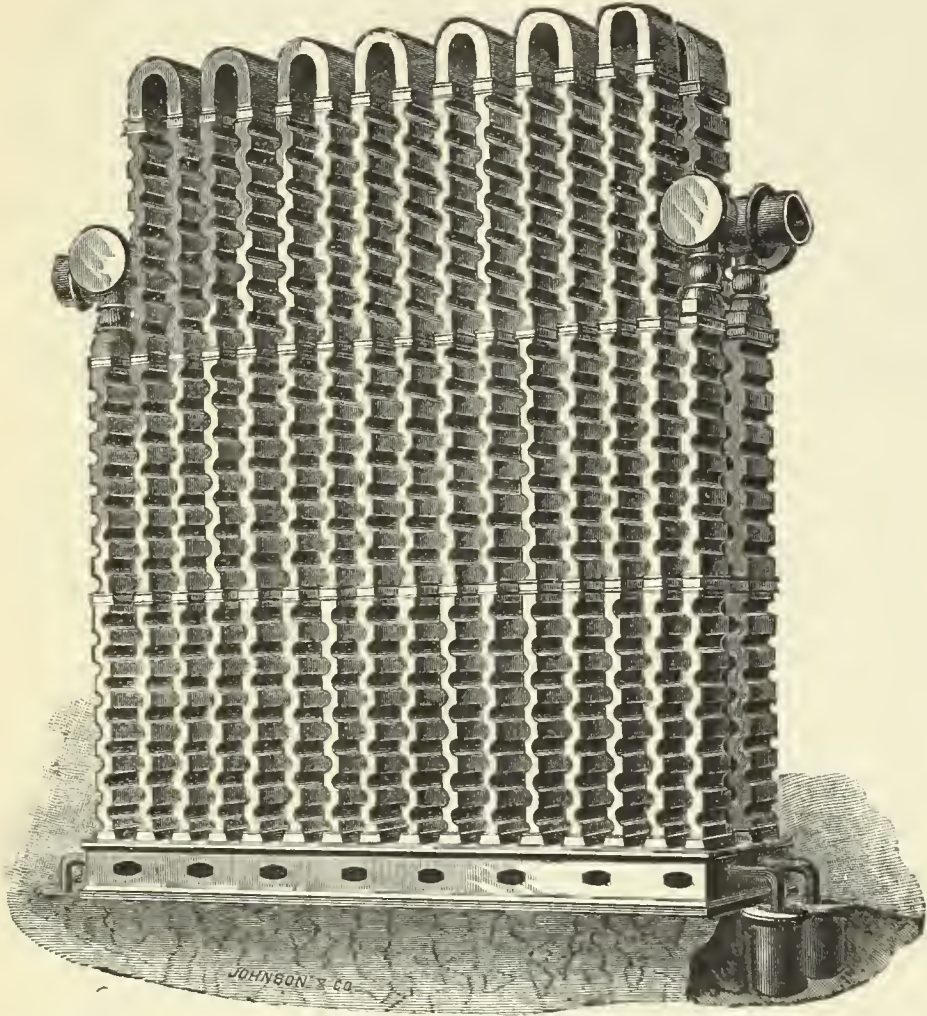
SINUOUS FRICTION CONDENSER.

We desire to draw the attention of the gas community to the merits of the **SINUOUS FRICTION CONDENSER**. Companies intending to introduce new condensers into their works will do well to confer with us and examine plans and estimates before contracting for any other pattern. The **FRICTION CONDENSER** is now in use at the gas works located in the following places:

Portland, Me.	Brookline, Mass.	Pawtucket, R. I.	Frederickton, N. B.
Newport, R. I.	Chelsea, Mass.	Jamaica Plain, Mass.	St. John, N. B.
Gloucester, Mass.	Woburn, Mass.	Attleboro, Mass.	Paterson, N. J.
Newton & Water- town, Mass.	Peoria, Ill.	Calais, Me.	Dover, N. H.
	Clinton, Mass.	Fall River, Mass.	Waltham, Mass.
		Nassau Works, Brooklyn, N. Y.	

DAVIS & FARNUM MFG. CO.

MANUFACTURERS OF

Gas and Water Pipes,

AND

GAS AND WATER MACHINERY

OF THE MOST APPROVED PATTERN.

Also, Gasholders and Iron Roofing.*Orders from Gas and Water Companies promptly attended to.***WALTHAM, MASS.**

Boston Office, Room 55, Mason Building, 70 Kilby Street.

DURING THE PAST YEAR, THE

NATIONAL GAS LIGHT AND FUEL CO.**218 LA SALLE ST., CHICAGO,**

Have Erected Twelve Sets of Water Gas Generating Apparatus under the *Springer Cupola* System. They are as follows:

Newton Illuminating Company, Newton, Kansas.— Daily capacity, 120,000 cu. ft.

Wellington Light & Heat Co., Wellington, Kansas.— Daily capacity, 120,000 cu. ft.

Chippewa Falls, Gas Light Co., Chippewa Falls, Wis.— Daily capacity, 120,000 cu. ft.

Elkhart Gas Light & Coke Co., Elkhart, Indiana.— Daily capacity, 120,000 cu. ft.

Madison City Gas Light Company, Madison, Wis.— Daily capacity, 120,000 cu. ft.

South Bend Gas Light Co., South Bend, Indiana.— Daily capacity, 250,000 cu. ft.

Sheboygan National Gas Comp'y, Sheboygan, Wis.— Daily capacity, 120,000 cu. ft.

Salina Gas Light Company, Salina, Kansas.— Daily capacity, 120,000 cu. ft.

Rathbun Company, Deseronto, Province Ontario.— Daily capacity, 80,000 cu. ft.

Jefferson City Gas Light Co., Jefferson City, Mo.— Daily capacity, 120,000 cu. ft.

Mankato Gas Light Company, Mankato, Minnesota.— Daily capacity, 80,000 cu. ft.

Minneapolis Gas Lt. & Coke Co., Minneapolis, Minn.— Daily capacity, 1,000,000 cu. ft.

1886**1886**

THE ALBO-CARBON LIGHT.

This most successful of all methods of enriching gas is based on the use of heated gas to vaporize a solid hydrocarbon, thus

COMBINING THE ADVANTAGES OF PREHEATING AND CARBURETTING.

The incoming gas passes over an extended heating surface (heated by means of the illuminating flames), and is raised to the temperature necessary to vaporize the carburetting material, which is a white, crystalline solid prepared from coal tar.

Two Seasons of Practical Use in all parts of the Country have amply demonstrated that the Albo-Carbon Light stands unrivaled for

ECONOMY, BRILLIANCY, EFFICIENCY.

Gas Companies are Finding this System Superior to All Others in enabling them to meet competition, as its adaptability to various requirements makes it equally as desirable to replace a KEROSENE LAMP, an INCANDESCENT LIGHT, or an ARC LIGHT.

Our Apparatus are made in all Sizes, from 1 to 48 Lights (25 to 1,500 C. P.)

To enable Gas Companies to still more successfully meet this competition and to offer to the public still cheaper forms of our lights, we have added

New and Attractive Designs at Low Prices.

Send for Illustrated Catalogue and New Price List.

NOTICE.

Suits are pending in the U. S. Circuit Courts in Illinois and Pennsylvania against various persons for infringement of our Letters Patent No. 247,925, dated Oct. 4, 1881, and No. 333,862, dated Jan. 5, 1886. All persons are cautioned against manufacturing, selling, or using any apparatus or material which infringes our Patents. We intend to commence suits against all parties infringing Patents owned by us.

The Albo-Carbon Light Co.,

NEWARK, N. J.,

Sole Manufacturers for the United States.

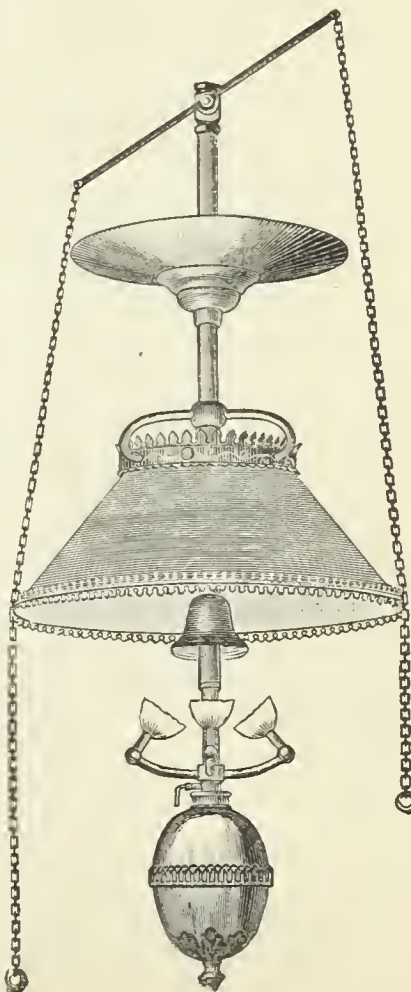
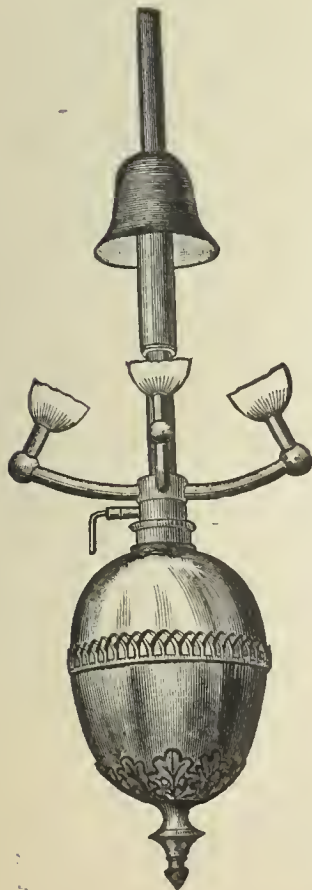
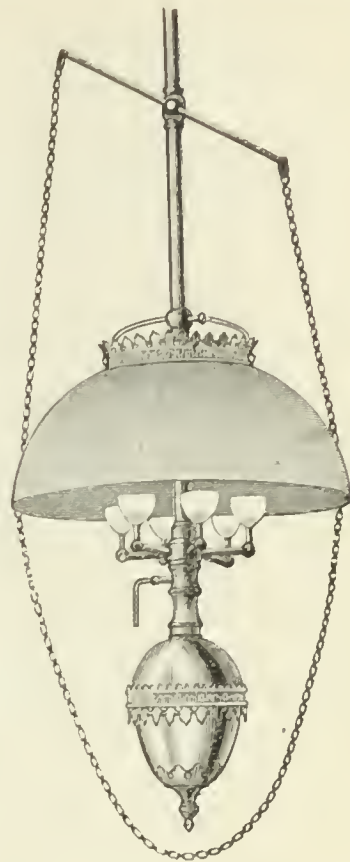

GAS ENGINES.

GAS ENGINES.

BOOKS.

THE CLERK GAS ENGINE CO.,

Main Office, 1012, 1014, 1016, 1018 Filbert St., Philadelphia, Pa.

WM. W. GOODWIN, Prest.

E. STEIN, Sec.

S. LEWIS JONES, Asst. Sec.

A. J. DOTY, Supt.

The utility and convenience of the Gas Engine being no longer an open question, it only remains now for intending purchasers to select the BEST. We claim for the CLERK GAS ENGINE that it is equal to any other manufactured as regards steadiness in running, simplicity, and ease of keeping in repair, and that it gives the greatest amount of power for the least money (both in first cost and expense of running) of any engine made. In support of this claim we refer to the test of the Gas Engines made under the direction of the American Institute of New York, in December, 1885, and heretofore published in these columns. These engines are especially adapted for continuous running under heavy loads, and we can refer to Engines which have run 22 hours a day for months at a time.

Made in Sizes of 5, 10, 15, 20, and 25 Horse Power. All Engines Guaranteed for One Year.

GAS

AS A SOURCE OF

LIGHT, HEAT, AND POWER.

By C. J. R. HUMPHREYS.

A Pamphlet of twenty-nine pages, treating of the use of Gas as a source of Light, Heat, and Power.

DESIGNED FOR DISTRIBUTION BY GAS COMPANIES AMONG THEIR CUSTOMERS AND OTHERS.

Price, 10 cents each, \$5 per 100, \$50 per 1,000.

Gas Companies can have their own imprint placed on cover without extra charge. All orders to be sent to

A. M. CALLENDER & CO.,

No. 42 Pine Street, N. Y. City.

GOODWIN'S DIRECTORY

OF THE

GAS LIGHT COMPANIES OF THE UNITED STATES & CANADA

Price, \$10.00.

Orders may be sent to

A. M. CALLENDER & CO., No. 42 Pine Street, N. Y. City.

CONNELLY'S AUTOMATIC GOVERNOR FOR STREET MAINS.

We invite the attention of all practical Gas Managers to the following letter and accompanying cut. The two lines show the pressure held by the Governor on Saturday and Sunday, and clearly illustrates the accuracy of the Governor in *increasing and reducing pressure in proportion to the volume of gas consumed.*

A Governor that puts the increased pressure on at "one fell swoop" and takes it off in like manner is *not* an "Automatic" Governor; and the circulation of pressure sheets showing such action by a so-called "Automatic" Governor is a rather amusing reflection on the intelligence of Gas Managers.

Strictly speaking, a "Balanced" Governor is an "Automatic" one, as it automatically varies the volume of gas sent out to *maintain a uniform pressure* at its outlet. But, as now applied, the term "Automatic Governor" is understood to mean a Governor that will *maintain pressure between any two desired extremes, in direct proportion to the volume of gas consumed.* Therefore pressure sheets showing *instantaneous changes* from maximum to minimum and *vice versa*, circulated broadcast as the record of an "Automatic (?) Governor," reveals inexcusable ignorance of the subject, amusing to many, yet liable to mislead the inexperienced novice.

We would suggest that all Gas Companies contemplating the placing of *Automatic* Governors would consult their own interests and avoid annoying experience by adopting a Governor *that has a record.*

CONNELLY & CO., LTD., 177 Broadway, N. Y.

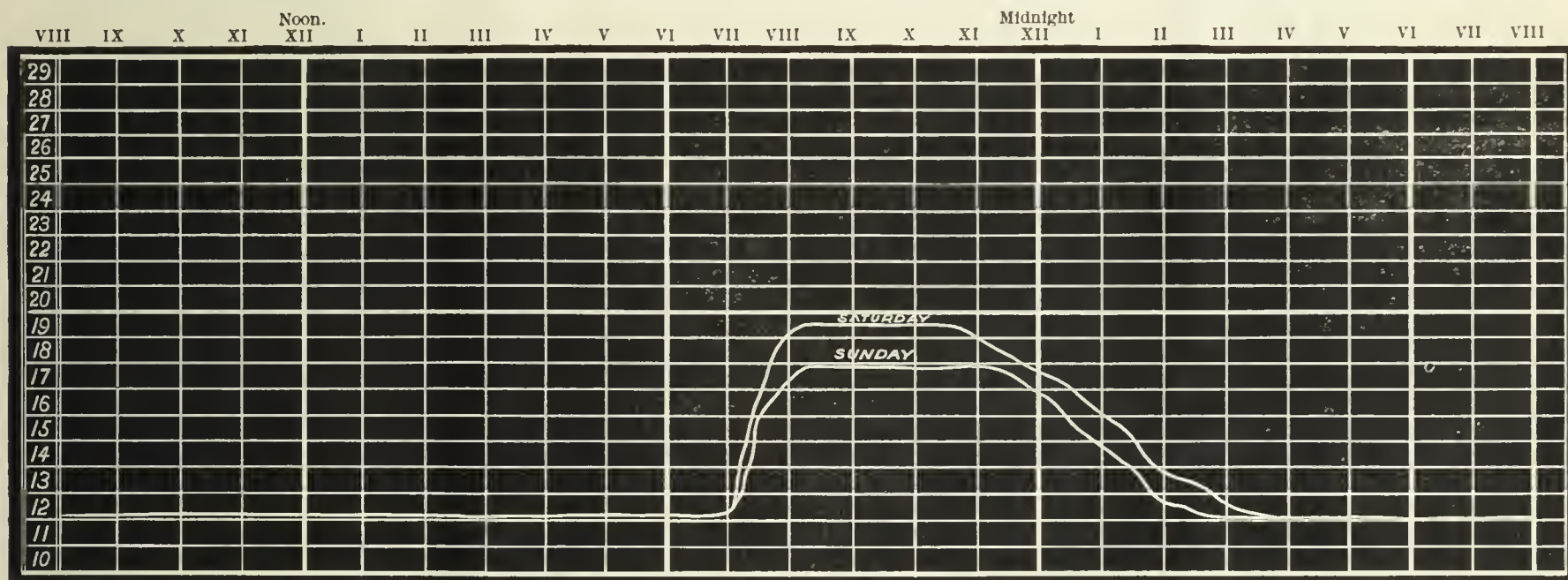

Card Showing Pressure at the Milwaukee Gas Works, Saturday, July 10, and Sunday, July 11 1886.

MILWAUKEE, Wis., August 3d, 1886.

MESSRS. CONNELLY & Co., LTD., 177 Broadway, New York:

Gentlemen—Replying to yours of 29th, I send you a little package of register sheets. When your Governor (20-inch) was set I adjusted it to give 13-tenths day pressure and 22-tenths night pressure. Saturday nights it would run up to 25-tenths. Whenever it would cloud up in the daytime it would go up at first indication of darkness to about 15-tenths. I hunted back in the sheets to find one when pressure was increased in the daytime, but it is so long since we have had a stormy day I could not find one. You can, however, see a *slight change* on sheets for June 1 and June 25. You will see, too, that lately the Governor only puts on *about 20-tenths maximum pressure.* This is because *less gas is burned than when it was adjusted.* We have no complaints of pressure, and everyone appears satisfied. In conclusion, can say the Governor has *never been touched* since it was first adjusted, and has at all times *done just the work we wished it to do.* Very truly yours, E. G. COWDERY, Engr. & Supt.

**T. C. HOPPER'S
AUTOMATIC DIFFERENTIAL GAS GOVERNOR**

Is now in Practical Operation, doing Perfect Automatic Service with Great Precision.

This Governor will do all and more than any other Governor on the Market.

BE SURE TO THOROUGHLY INVESTIGATE THE SUPERIOR MERITS OF THIS GOVERNOR BEFORE PURCHASING.

For Simplicity and Reliable Work it has no Equal. Correspondence Solicited.

T. C. HOPPER & CO., - - Manufactory, 2227 Wood Street, Phila, Pa.

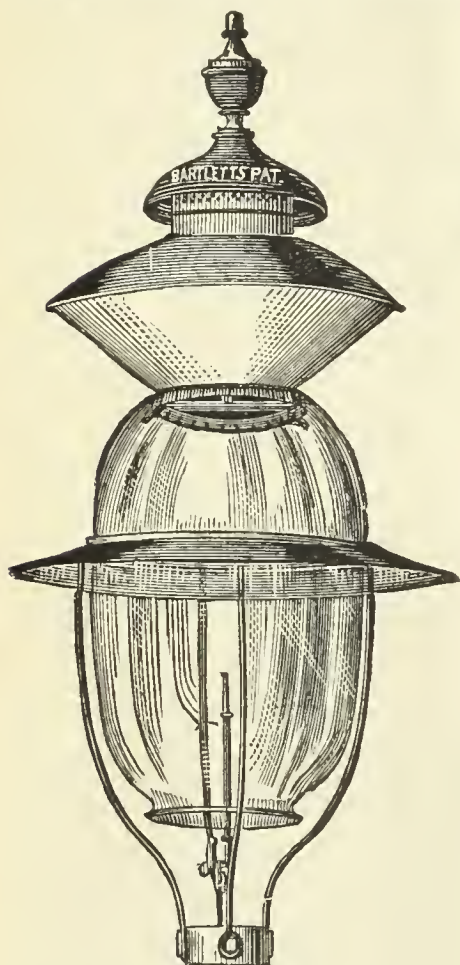

G. S. COOK, Pres. THOS. DAVENPORT (late Davenport Bros.), Sec. & Treas

**BARTLETT
Street Lamp Mfg. Co.**

MANUFACTURERS OF

Bartlett's Patent

GLOBE LAMPS.

FOR

Streets, Parks, Railroad Stations, Public Buildings, Etc.

LAMP POSTS A SPECIALTY.

Office and Salesroom

No. 35 Howard Street, N. Y. City.

Gas Companies and others intending to erect lamps and posts will do well to communicate with us.

F. M. ROOTS.

S. C. ROOTS

D. T. ROOTS.

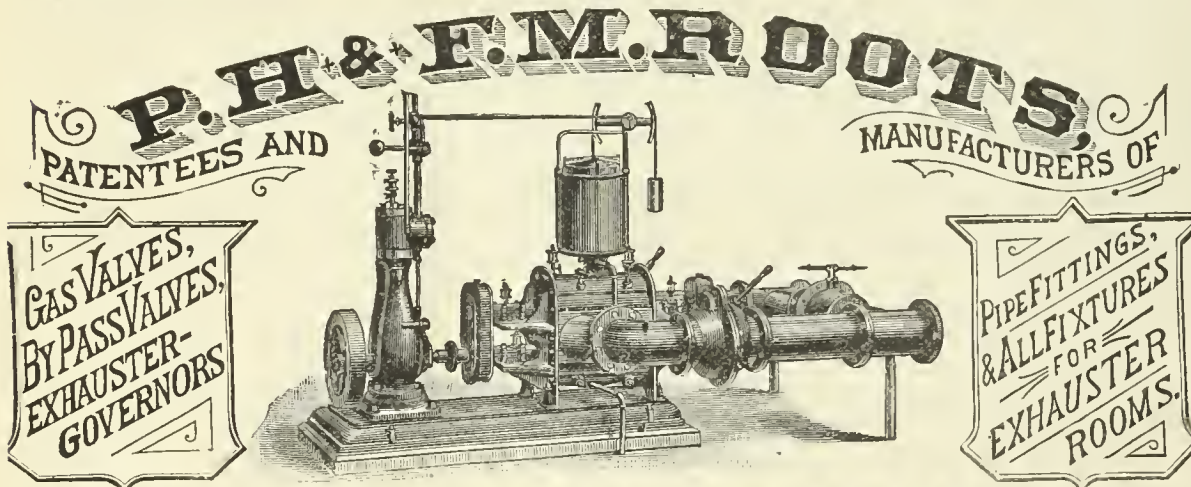

IMPROVED GAS EXHAUSTER,

WITH ENGINE ON SAME BED PLATE, OR WITHOUT.

BYE-PASSES, GAS VALVES, GOVERNORS, ELBOWS, PIPE-FITTINGS, Etc., FURNISHED TO ORDER,

P. H. & F. M. ROOTS, Patentees & Manufacturers, **CONNERSVILLE, IND.**

S. S. TOWNSEND, General Agent, 22 Cortland St.

COOKE & CO., Selling Agents, 22 Cortland St., N. Y.

✻ SEND FOR ILLUSTRATED CATALOGUE AND PRICE LIST. ✻

CONNELLY & CO., LTD.

MANUFACTURERS OF

Steam-Jet Exhausters

Requires one-half the floor space and one-third less steam than any other Exhauster in the market. More cheaply and easily connected, as outside by-pass valves are dispensed with. It is the only Exhauster manufactured having Compensator and Governor combined; the Compensator with all other Exhausters being a separate and distinct machine. It is simple in construction, easily adjusted, not liable to get out of order, and can be operated by ordinary workmen. Over 1,000 now in use.

No. 177 Broadway, New York.

LUDLOW VALVE MFG. CO.

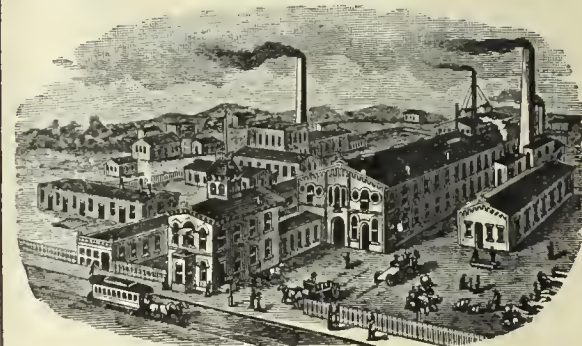

OFFICE AND WORKS,

93S to 954 River Street and 67 to 83 Vail Av. TROY, N. Y.

Hydraulic Main Dip Regulators, also Check Valves, Foot Valves, Yard wash and Fire Hydrants. Send for Circulars.

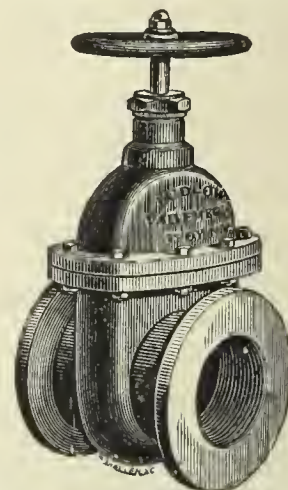

Valves.—Double and Single Gate, 1/2 in. to 48 in., outside and inside Screws. Indicator, etc., for Gas, Water, Steam, and Oil. Send for Circulars.

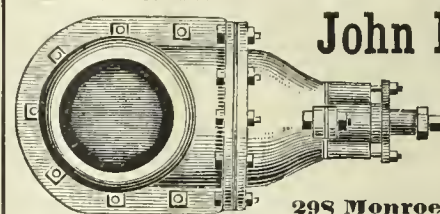

John McLean

Man'facturer of

GAS VALVES.

298 Monroe Street, N. Y.

GAS vs. ELECTRIC LIGHT.

We would invite attention to the able and exhaustive argument of General A. Hickenlooper, President of the Cincinnati Gas Light and Coke Company, contained in a handsome pamphlet of 96 pages, entitled

"EDISON'S INCANDESCENT ELECTRIC LIGHTS FOR STREET ILLUMINATION. REPORT OF AN ARGUMENT DELIVERED BY A. HICKENLOOPER BEFORE THE COMMITTEE ON LIGHT, MUNICIPAL COUNCIL, CITY OF CINCINNATI, JULY 22, 1886."

This is a subject of special interest to all Gas Light Companies.

Prices.

25 copies..... \$7.50 100 copies..... \$22.50
50 copies..... 12.50 250 copies..... 50.00

A sample copy will be sent by mail on receipt of 50 cts.

A. M. CALLENDER, & CO., 42 PINE ST., N. Y. CITY.

C. W. HUNT CO.,

No. 111 Broadway, N. Y. City.

MANUFACTURERS OF

Coal Handling Machinery,

AUTOMATIC RAILWAY, HOISTING ELEVATOR, CABLE RAILWAY, STEAM SHOVEL, HOISTING ENGINES, COAL TUBS, COAL & COKE CARS.

Plans and Specifications made for the

Erection of Coal Storage Buildings

Send for a Descriptive Pamphlet.

GAS STOVES.

GAS STOVES.

GAS STOVES.

THE AMERICAN METER CO.,

MANUFACTORIES,

508 to 514 West Twenty-second St., N. Y.

Arch and Twenty-second St., Phila.

Nos. 244 & 246 North Wells Street, Chicago, Ill.

AGENCIES,

No. 177 Elm Street, Cincinnati, Ohio.

Nos. 122 & 124 Sutter Street, San Francisco Cal.

No. 810 North Second Street, St. Louis, Mo.



Open Fire Place Heater No. 19.
Fitted with the new Incandescent Gas Fire.

NEW
INCANDESCENT
Gas Fires
AND
OPEN
Fire Place
Heaters.

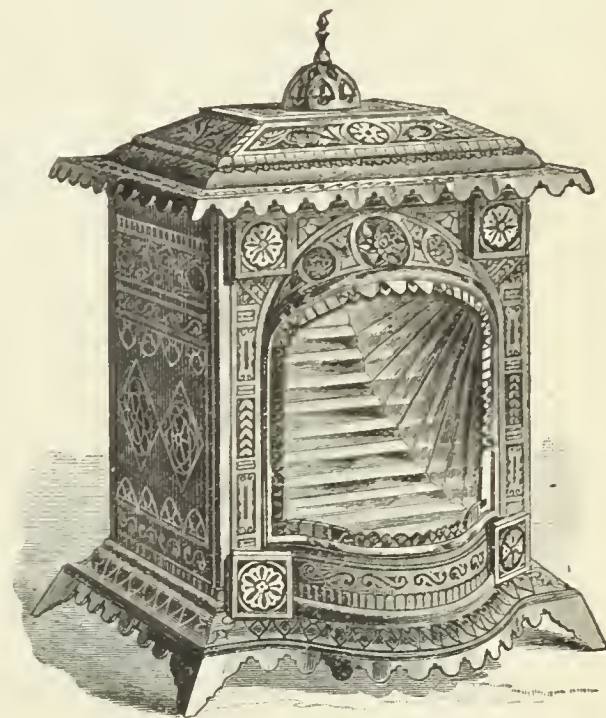

Open Fire Place Heater No. 17C.
Fitted with Illuminating Burners and Copper Reflectors.

We call attention to Special Apparatus Heated by Gas for Manufacturing Purposes.

GAS FURNACES FOR TINMEN'S USE; FURNACES FOR MELTING SOLDER AND TYPE METAL; APPARATUS FOR BENDING CARRIAGE PANELS, NOW IN SUCCESSFUL OPERATION IN CARRIAGE MANUFACTORIES; WATER HEATERS FOR KITCHEN BOILERS, BATHS, ETC., AND FOR ATTACHING TO HEATING COILS AND PIPES FOR CONSERVATORIES.

THE COMPANY MANUFACTURE

GAS STOVES FOR COOKING AND HEATING PURPOSES

In all Sizes, for Domestic, Restaurant, and Hotel Use.

These Stoves may be seen in operation at our Retail Store, No. 223 Sixth Avenue, N. Y. Call and examine.

SEND FOR CATALOGUE OF TWENTY DIFFERENT STYLES OF HEATING STOVES.

RETORTS AND FIRE BRICK.

J. H. GAUTIER & CO.,

CORNER OF

GREENE AND ESSEX STREETS,
JERSEY CITY, N. J.

MANUFACTURERS OF

**Clay Gas Retorts,
Gas House Tiles,
Fire Bricks, Etc. Etc.**Ground Clay, Fire Brick and
Fire Sand in Barrels,J. H. GAUTIER.
C. E. GREGORY.T. B. GAUTIER.
C. E. GAUTIER.**BROOKLYN**

Clay Retort & Fire Brick Works,

(EDWARD D. WHITE & CO.)

Manufacturers of Clay Retorts, Fire Brick,
Gas House and other Tile.VAN DYKE, ELIZABETH, RICHARDS & PARTITION STS.
Office, 88 Van Dyke St., Brooklyn, N. Y.

RETORTS AND FIRE BRICK.

LACLEDE FIRE BRICK MFG. CO.,

MANUFACTURERS OF

Fire Brick, Gas Retorts,

AND

ST. LOUIS STANDARD SEWER PIPE.Blast Furnace and Cupola Linings, every description of Fire
Clay Material, Fire Clay Flue Linings, Chimney Tops
Dry Milled and Crude Fire Clays, etc.

OFFICE AND DEPOT

901, 903, and 905 Pine Street,
ST. LOUIS, MO.

ESTABLISHED IN 1845.

B. KREISCHER & SONS,

OFFICE FOOT OF HOUSTON ST., E. R., N. Y.

Gas Retorts,**TILES, FIRE BRICK.**

AND EVERYTHING IN THE FIRE CLAY LINE.

RETORTS AND FIRE BRICK.

MANHATTAN

FIRE BRICK & ENAMELLED CLAY

RETORT WORKS.**ADAM WEBER.****CLAY GAS RETORTS**

AND RETORT SETTINGS

FIRE BRICKS, TILES, ETC.,

Office and Works, 15th Street and Avenue C., N. Y.

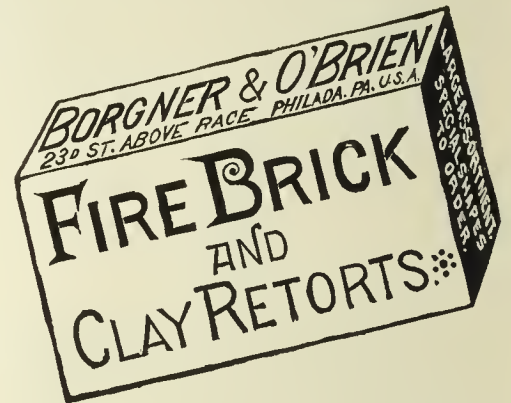
Works,
LOCKPORT STATION, PA.

—ESTABLISHED 1864.—

JAMES GARDNER, JR.,

Successor to WILLIAM GARDNER & SON.

Fire Clay Goods for Gas Works.

CHAS. H. SPRAGUE & SON, No. 70 KILBY STREET, BOSTON, MASS., Agents for the New England States.

Office, Rooms 19 & 20, Lewis Block,
PITTSBURGH, PA, P. O. Box 373.

OFFICE, 418 to 422 East 23d St., New York.

ESTABLISHED 1856.

WORKS, PERTH AMBOY, NEW JERSEY.

HENRY MAURER,**Excelsior Fire Brick & Clay Retort Works**

CLAY GAS RETORTS, BENCH SETTINGS, FIRE BRICK, TILES, ETC.

CHICAGO

Retort & Fire Brick Works,

OFFICE AND FACTORY,
Clark, Forty-Fifth, and La Salle Streets,
CHICAGO, ILL.

GEORGE C. HICKS, PRES. PAUL P. USTIN, SEC. & TREAS.

STANDARD

Clay Retorts and Settings.

BLOCKS & TILES

Of every Shape and Size to Order.

Standard Fire Bricks.**NEWBIGGING'S****Gas Manager's Handbook.***Price, \$4.80.*

EVERY GAS MAN SHOULD HAVE ONE.

Orders may be sent to this Office.

OAKHILL**GAS RETORT & FIRE BRICK**

Works.

Proprietors,

PARKER-RUSSELL MINING & MFG. CO.

City Office, 711 Pine Street,

ST. LOUIS, MO.

Our immense establishment is now employed almost entirely in
the manufacture of**MATERIALS FOR GAS COMPANIES.**We have studied and perfected three important points. Our re-
torts are made to stand changes of temperature, the strongest
heats of the furnace, and the abrasion of feeding and emptying.
Our customers are in almost every State of the Union, to all of
whom we refer.

THOS. SMITH, Prest. AUGUST LAMBLA, Vice-Prest. & Sup

BALTIMORE**RETORT & FIRE BRICK CO.**

MANUFACTORY AT

LOCUST POINT, BALTIMORE, MD.

Connection with the City by Telephone.

Clay Retorts, Blocks & Tiles,

FIRE BRICK, FIRE CLAY,

AND FIRE CEMENT.

Red and Buff Ornamental Tiles and Chim-
ney Tops. Drain and Sewer Pipe (from
2 to 30 inches). Baker Oven Tiles
12 x 12 x 2 and 10 x 10 x 2.

WALDO BROS., 88 WATER ST., BOSTON, MASS

Sole Agents the New England States

RETORTS AND FIRE BRICK.

REGENERATIVE FURNACES.

STEAM PUMPS.

EVENS & HOWARD,

916 Market St., St. Louis. Mo.

Works, Howard Station, Mo. Pacific R.R.

Fire Brick, Gas Retorts

AND

RETORT SETTINGS.

Sewer Pipe, 3 to 24 in. diameter.

Glass Pot Clay, Ground Fire Clay, in barrels and in bulk. All kinds of Fire Clay Goods.

Cincinnati Gas Retort & Fire Brick Works.

—ESTABLISHED 1872.—

CHAS. TAYLOR,

MANUFACTURER OF

Gas Retorts, Fire Brick, and Tile.

Blast Furnace Linings, Cupola Blocks, Boiler Tiles, Grate Settings, and Stove Linings. Fire Cement, Fire Clay, Fire Sand, and all other Fire Clay Goods.

Branch Works, New Cumberland, W. Va.

GENERAL OFFICE AND WORKS,

Burns St., Cincinnati, Ohio.

Stettiner

Chamotte Fabrik Actien Gesellschaft,

Formerly **DIDIER,**

(Patentees of the Dr. Schilling & Dr. Bunte Regenerative Furnace)

STETTIN, GERMANY.

The attention of all Gas Engineers is called to our Fire-Proof Material, viz.:

CLAY GAS RETORTS

(ENAMELED AND UNENAMELED),

Blocks, Tiles

AND

EXTRA FIRE BRICK,

Pronounced by the highest authorities as superior to and exceeding any other similar manufacture. The component of aluminum contained in our material (up to 45 per cent.) is larger than in any other material heretofore sold in the United States; whilst the uniformity of the goods is assured by the most scrupulous analysis of the clay used.

For any further information and prices please apply to

EMIL LENZ,

2 & 4 Stone St., Room 19, N.Y. City.

PATENTS.

FRANKLIN H. HOUGH,

Solicitor of American & Foreign Patents

925 F. ST., WASHINGTON, D. C.

(NEAR U. S. PATENT OFFICE.)

Personal attention given to the preparation and prosecution of applications for Letters Patent. All business before the U. S. Patent Office attended to for moderate fees. **No Agency in the United States possesses superior facilities for obtaining Patents,** or for ascertaining the patentability of inventions. Copies of patents furnished for 25 cents each. Correspondence solicited.

ADAM WEBER'S

New and Improved Regenerative Furnace.

ESPECIALLY ADAPTED FOR USE IN SMALL GAS WORKS.

A Saving of at Least Forty per Cent. over Old Methods.

Cheapness of construction and absence of elaboration are the chief characteristics of this Furnace. It is also applicable in cases where it is not convenient to excavate deeply below the line of the retort house.

Correspondence respectfully solicited. Descriptive Circulars on application.

Manhattan Fire Brick & Enameled Clay Retort Works.

OFFICE, 633 EAST FIFTEENTH STREET, N. Y. CITY.

MUNICH REGENERATIVE FURNACE

System Drs. Schilling and Bunte.

Greatest Durability! Minimum of Attention!

COMPLETE DISTILLATION IN 3½ HOURS.

Ten to Thirteen Pounds of Coke to Hundredweight of Coal.

NO CLINKER. NO CARBONIC OXIDE IN THE REGENERATIVE FLUES.

Almost Automatic in Action.

The Most Successful Regenerative Furnace in Use.

BARTLETT, HAYWARD & CO.

Agents for the United States.

THE A. S. Cameron Steam Pump,

THE STANDARD OF EXCELLENCE.

Upward of 30,000 in Use.

BEST GAS WORKS PUMP

Ever Introduced.

Adapted to Every Possible Duty.

A. S. Cameron Steam Pump Works.

Foot East 23d St., N. Y.

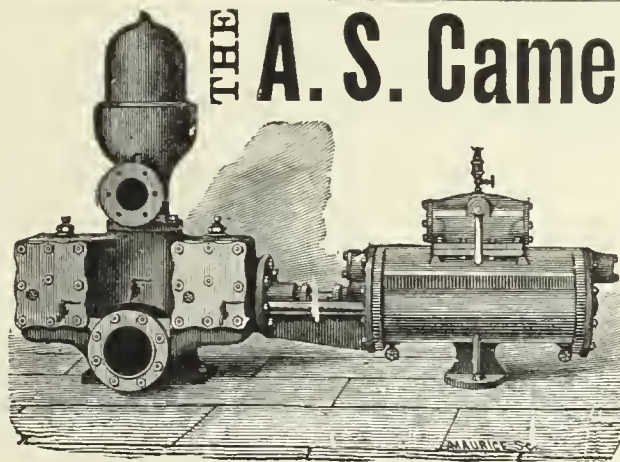

GEO. SHEPARD PAGE,

No. 69 Wall Street, N. Y. City.

REPRESENTING

THE BOWER GAS LAMP.

C. & W. Walker's Carbonic Acid & Tar Extracting Washer

B. DONKIN & CO.'S PAT. IMP. GAS VALVE.

Young & Beilby's Patents. Henry Aitkin's Patents.

R. P. SPICE, London, Eng. HENRY SIMON, Manchester, Eng.

GAS AND WATER PIPES.

GAS AND WATER PIPES.

ENGINEERS.

SAM'L R. SHIPLEY, Pres.
HENRY B. CHEW, Treas.

JAS. P. MICHELLON, Sec.
WM. SEXTON, Supt.

P. D. WANNER, Chairman. A. H. MELLERT, Sec. & Treas.

GLOUCESTER IRON WORKS,
GLOUCESTER CITY, N. J.



Cast Iron Gas & Water Pipes, Stop Valves, Fire Hydrants, Gasholders, &c.

Office No. 6 North Seventh Street, Philadelphia.

ESTABLISHED 1856.

WARREN FOUNDRY AND MACHINE CO.,

WORKS AT PHILLIPSBURGH, N. J.
NEW YORK OFFICE, 162 BROADWAY.

Cast Iron Water and Gas Pipe

FROM TWO TO FORTY-EIGHT INCHES DIAMETER.
ALSO ALL SIZES OF

FLANGE PIPE for Sugar House and Mine Work.

Branches, Bends, Retorts, Etc., Etc.

436-1

MATTHEW ADDY, President.

W. L. DAVIS, Selling Agent.

GEO. P. WILSHIRE, Sec. & Treas.

Cincinnati and Newport Iron and Pipe Company,

NEWPORT, KY.

Lamp Posts

AND

BENCH CASTINGS

A Specialty.

Manufacture Pipe from 2 to 48 inches. All work guaranteed first quality.

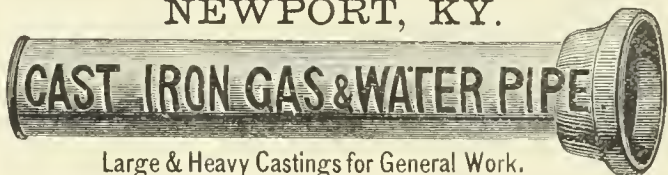

Branch

AND

SPECIAL CASTINGS

FOR GAS & WATER CO'S.

Pancoast & Rogers.

WROUGHT IRON PIPE,

VALVES AND GATES,

Cast Iron Gas & Water Pipe.

28 Platt and 15 Gold St., New York.

The Management of Small Gas Works.

By C. J. R. HUMPHREYS. Price, \$1.

A. M. CALLENDER & CO., 42 Pine St., N. Y.

MELLERT FOUNDRY & MACHINE CO., Ltd.
Reading, Pa.

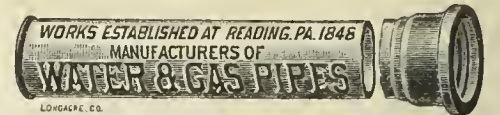

Specials—Flange Pipe, Valves and Hydrants,
Lamp Posts, Retorts, etc.

General Foundry and Machine Work.

JOHN FOX, Selling Agent. 160 Broadway, N. Y.

CAST IRON

Gas and Water Pipes,

From 2 to 48 inches in Diameter

JOHN FOX,

160 Broadway, N. Y. City.

THE OHIO PIPE COMPANY,

MANUFACTURERS OF

Cast Iron Gas & Water Pipe,

BRANCH AND SPECIAL CASTINGS.

Gas-House Bench Castings, Hydraulics, Lamp Posts, Flange Pipe
and Specials, Architectural Castings, Building Columns,
Joists, Cellar Grates, Sash Weights, etc.

GENERAL FOUNDERS AND MACHINISTS.

Columbus, Ohio.

M. J. DRUMMOND,



SPECIAL CASTINGS AND LAMP POSTS.

95 Liberty St., - New York.

JOS. R. THOMAS, C.E.,

May be Consulted on all Mat-
ters Relating to Gas Works
and Gas Manufacture.

ADDRESS THIS OFFICE.

WM. FARMER, ENGINEER,

32 Park Place, Room 36, New York.

THE CHEMIST'S ASSISTANT; OR, KINDERGAR-
TEN SYSTEM OF CHEMISTRY.

A system by which the elements and their valences are repre-
sented by illustrations and solid bodies.

BOX AND PAMPHLET COMPLETE, \$2.50.

WM. HENRY WHITE,

CONSULTING AND CONSTRUCTING

Gas Engineer & Contractor

Estimates, Plans, and Specifications furnished for new wo
extensions of existing works.

No. 32 Pine Street, New York City.

Correspondence solicited.

GAS LAMPS.

SCRUBBERS AND CONDENSERS.

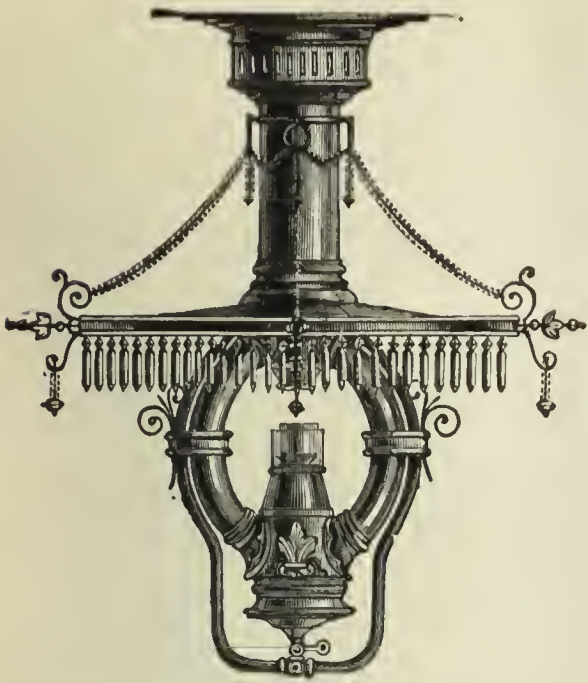

SIEMENS LAMP.

The Siemens and Lungren REGENERATIVE GAS LAMPS.

A System of Burning Gas whereby its Illuminating Power is Increased from 300 to 400 per ct. without the Expense, Trouble and Annoyance resulting from the use of Hydrocarbon Enriching Material.

The Siemens-Lungren Company received the only Silver Medal or Highest Award for Gas Burners at the "Novelties" Exhibition of the Franklin Institute, held at Phila., Oct., '85.

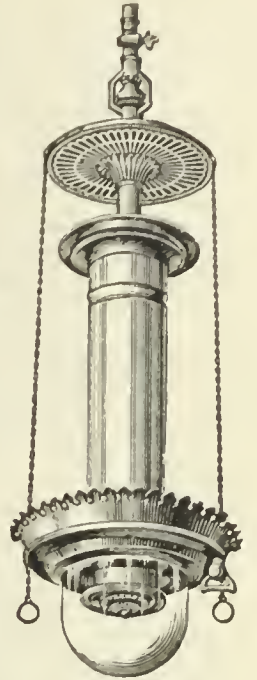

LUNGREN LAMP.

THIRTEEN CANDLE POWER PER CUBIC FOOT OF GAS!

This result is obtained

SIMPLY BY THE SCIENTIFIC APPLICATION OF THE REGENERATIVE PRINCIPLE.

Consequently this largely increased illumination is always maintained without further cost and frequent attention.

THE SIEMENS-LUNCREN COMPANY,

N. E. Cor. 21st. St. and Washington Av., Phila., Pa.

THE "STANDARD" WASHER-SCRUBBER.

The "Standard" Washer-Scrubber has been adopted very generally by Gas Companies in North and South America, Europe, Asia, Australia, and New Zealand.

NO OTHER APPARATUS REMOVES ALL THE AMMONIA FROM THE GAS.

Its dimensions admit of placing it under cover without the great expense incurred in a high building to protect Tower Scrubbers from changes of temperature; thus the "Standard" Washer-Scrubber costs much less than other systems.

J. B. Crockett, Esq., President and Engineer of the San Francisco Gas Light Company, writes, under date of May 22, 1886:

"The 'Standard' Scrubbers have been in constant operation for the past six months, and have given entire satisfaction. We have tried them under many different conditions, and find that, by the use of about two gallons of water per thousand feet of gas, it gives us Liquor of 15 oz. strength. Our coal is from British Columbia, and contains large quantities of Ammonia, and we found it impossible to remove all the Ammonia with one gallon of water; but with two gallons we get good, strong Liquor, and at the same time have no traces of Ammonia at the outlet."

Recent Orders for "Standard" Washer-Scrubbers have been received from

J. P. HARBISON, ESQ., Treas. Hartford City Gas Light Company, and Prest. New England Association of Gas Engineers.
L. N. VAN KEUREN, ESQ., Secretary Bridgeport Gas Light Company - - - - - Bridgeport, Conn.
W. H. PEARSON, ESQ., Secretary and General Manager Consumers Gas Light Company, - - - - - Toronto, Can.
E. M. BREESE, ESQ., Engineer and Superintendent Detroit Gas Light Company, - - - - - Detroit, Mich.

GEO. SHEPARD PAGE, No. 69 WALL STREET, NEW YORK,

SOLE AGENT FOR THE WESTERN HEMISPHERE.

GAS WORKS APPARATUS AND CONSTRUCTION.

GAS WORKS APPARATUS AND CONSTRUCTION.

WORKS: { MILLVILLE, N. J.
FLORENCE, " "
CAMDEN, " "

R. D. WOOD & CO.,

OFFICES: { 400 CHESTNUT ST.,
PHILADELPHIA.

CAST-IRON PIPE 1½ to 72 Inches in Diameter.

Water Machinery and Gas Apparatus.

HEAVY CASTINGS.

HOLDERS,

PURIFIERS,

FLOORS AND ROOFS,

LAMP POSTS,

CONDENSERS,

FLANGED PIPE,

VALVES,

BENCH WORK,

FIRE HYDRANTS,

METER CASES.

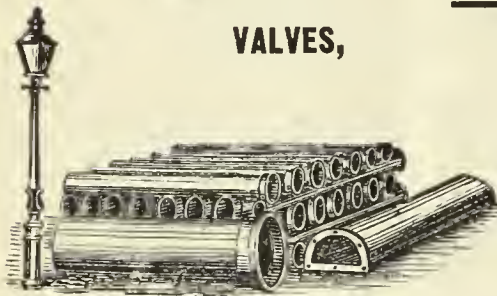

Estimates and Specifications for
NEW WORKS or **EXTENSIONS**
or **ALTERATIONS** of **OLD ONES.**

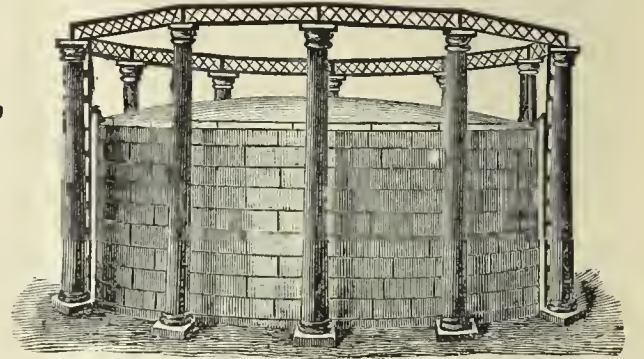

W. E. TANNER, Pres. W. R. TRIGG, Vice-Pres. A. DELANEY, Supt.

Tanner & Delaney Engine Co.,
RICHMOND VA.

GAS APPARATUS,

INCLUDING

Condensers of Various Styles

SCRUBBERS, PURIFIERS, HOLDERS,

Castings for Retort Houses, Etc.

ALSO STEAM ENGINES AND BOILERS.

Plans, Specifications, and Estimates Furnished.

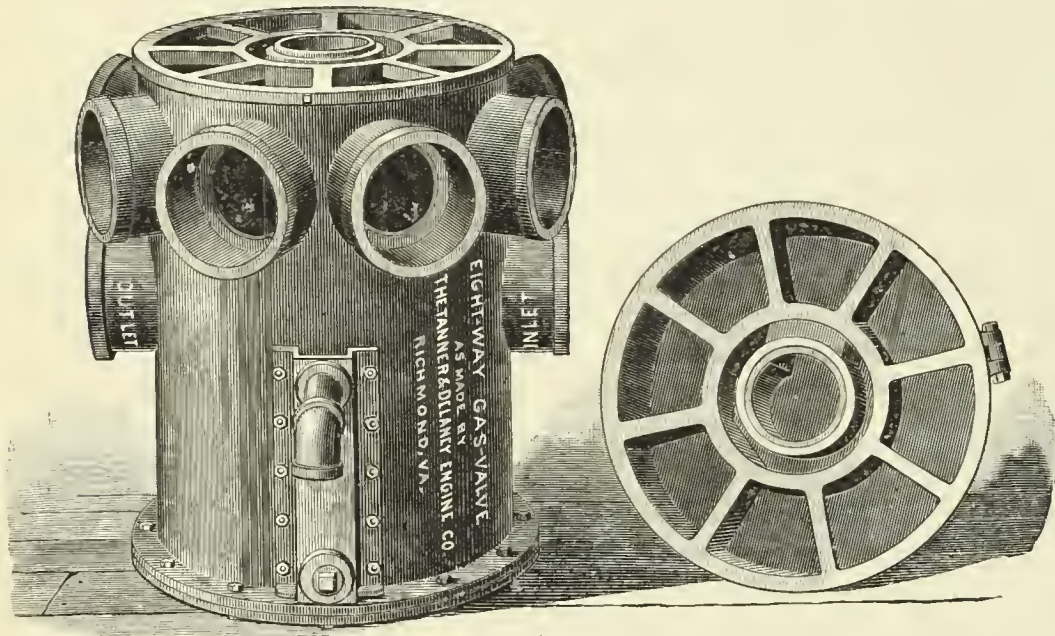

SMITH & SAYRE MFG. COMPANY,

G. G. PORTER, Prest.

245 Broadway, N. Y.

CHAS. W. ISBELL, Sec'y.

Machinery & Apparatus for Gas Works

Drawings, Plans, and Estimates Furnished for the Improvement, Extension, or Alteration of Gas Works, or for the Construction of New Works.

Mackenzie's Patent Rotary and Steam Jet Gas Exhausters, Governors, Compensators, Condensers, Washers, Scrubbers. Isbell's Patent Automatic Street Pressure Governor, Gas and Water Valves, Hydraulic Main Dip Regulator, Bench Castings, etc. Purifying Boxes and "Standard" Scrubbers. Isbell's Patent Self-Sealing Retort Doors.

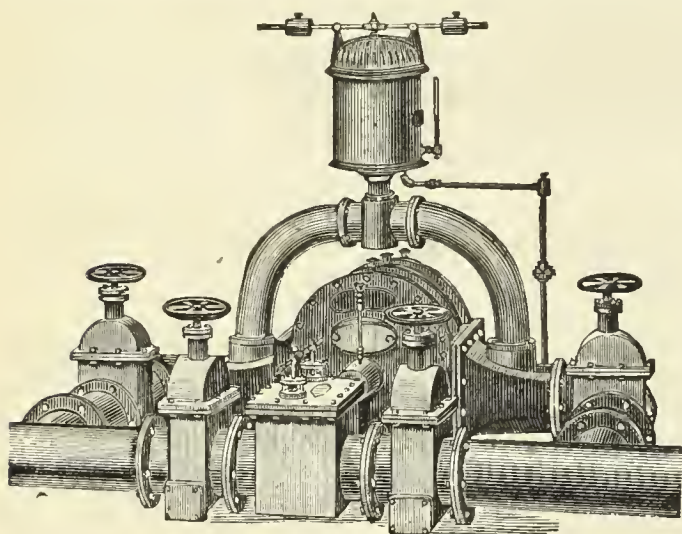

SOUTHWARK FOUNDRY AND MACHINE COMPANY,

Successors to MERRICK & SONS,

GAS APPARATUS,

Holders, Purifiers, Washers, Etc., Etc. Boiler and Tank Work. Steam Engines. Hydraulic Machinery. Bessemer Plants, Etc.

Washington Ave. and Fifth Street, Philadelphia, Pa.

MORRIS, TASKER & CO.,

Limited,

Builders of Gas Works,

PHILADELPHIA PA.

GAS WORKS APPARATUS AND CONSTRUCTION.

GAS WORKS APPARATUS AND CONSTRUCTION.

JAMES R. FLOYD,

(SUCCESSOR TO HERRING & FLOYD)

Oregon Iron Works,

531 to 543 West 20th St., N. Y.

Practical Builders of Gas Works,

MANUFACTURERS OF

ALL KINDS OF CASTINGS

AND

APPARATUS FOR GAS-WORKS.

BENCH CASTINGS

from benches of one to six Retorts each.

WASHERS: MULTITUBULAR AND AIR CONDENSERS; CONDENSERS; SCRUBBERS

wet and dry), and

EXHAUSTERS

for relieving Retorts from pressure.

BENDS and BRANCHES

all sizes and description.

FLOYD'S PATENT

MALLEABLE RETORT LID.

PATENT

SELF-SEALING RETORT LIDS.

FARMER'S

PATENT BYE-PASS DIP-PIPE.

SABBATON'S PATENT

FURNACE DOOR AND FRAME.

BUTLER'S

COKE SCREENING SHOVELS.

GAS GOVERNORS,

and everything connected with well regulated Gas Works at low price, and in complete order.

SELLER'S CEMENT

for stopping leaks in Retorts.

N. B.—STOP VALVES from three to thirty inches—

at very low prices.

Plans, Specifications, and Estimates furnished.

KERR MURRAY MFG. CO.,

MANUFACTURERS OF

Single Lift and Telescopic

GASHOLDERS.

Built, 1884:

Altoona, Pa	Capacity, 160,000 cubic feet.
Pittsburgh, Pa.....	" 250,000 "
" "	" 220,000 "
Bellaire, Ohio.....	" 50,000 "
Youngstown, Ohio.....	" 60,000 "
Canton, "	" 60,000 "
Akron, "	" 80,000 "
Xenia, "	" 10,000 "
Adrian, Mich.....	" 65,000 "
Ypsilanti, Mich.....	" 25,000 "
Muskegon, "	" 70,000 "
South Bend, Ind.....	" 70,000 "
Anderson, "	" 20,000 "
Plainfield, "	" 10,000 "
Springfield, Illinois.....	" 100,000 "
Evanston, "	" 50,000 "
Freeport, "	" 35,000 "
Elgin, "	" 60,000 "
Sheboygan Wis.....	" 20,000 "
Key West Fla.....	" 10,000 "

Plans and estimates furnished for the erection of new and the rebuilding of old works. Address

Kerr Murray Mfg. Co.,

FORT WAYNE, IND.

CONTINENTAL WORKS.

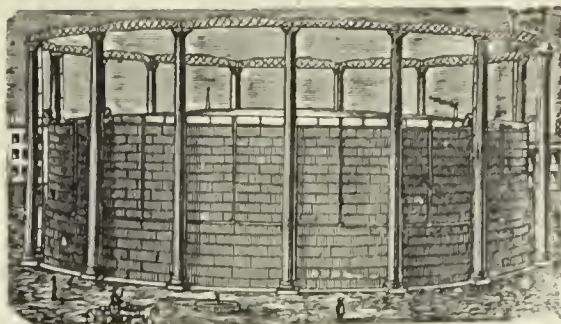

GASHOLDERS OF ANY MAGNITUDE.

T. F. ROWLAND, Proprietor,

GREENPOINT, BROOKLYN, N. Y.

ENGINEER AND MANUFACTURER OF

GAS-HOLDERS.

CONDENSERS, SCRUBBERS, VALVES,

PURIFIERS, RETORTS, and HY-

DR AULIC MAINS,

and all other articles connected with the Manufacture and Distribution of Gas. Plans and Specifications prepared and Proposals given for the necessary Plant for Lighting Cities, Towns, Mansions, and Manufactories.

H. RANSHAW, Prest. & Mangr.

WM. STACEY, Vice-Prest.

T. H. BIRCH, Asst. Mangr.

R. J. TARVIN, Sec. & Treas.

STACEY MFG. CO.,

MANUFACTURERS OF

Single and Telescopic Gasholders,

IRON ROOFS, BRIDGES, LAMP POSTS,

Water and Oil Tanks, Coal Elevator Cars,

COKE CRUSHERS, BENCH CASTINGS,

And all kinds of Wrought and Cast Iron Work used in the erection of Coal and Oil Gas Works. Rolling Mill Machinery and Heavy Castings a Specialty.

Foundry:

33, 35, 37 & 39 Mill Street.

Wrought Iron Works:

16, 18, 20, 22, 24 & 26 Ramsey Street.

Cincinnati, Ohio.

BARTLETT, HAYWARD & CO.,

Office, German & Calvert.

BALTIMORE, MD.

Works, Pratt & Scott.

PURIFIERS.

ROOFS.

Bench Castings.

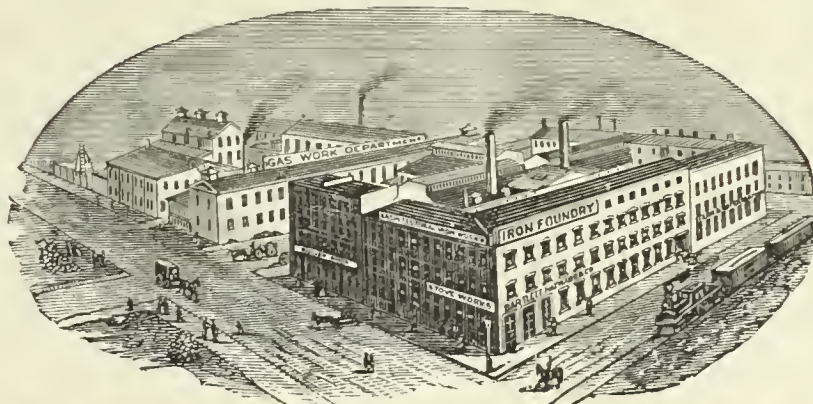

SCRUBBERS.

BOILERS.

CONDENSERS.

GASHOLDERS.

CONSTRUCTING ENGINEERS AND BUILDERS OF GAS WORKS.

1842. DEILY & FOWLER, 1886.

Laurel Iron Works.

Address, No. 39 Laurel Street, Philadelphia, Pa.

MANUFACTURERS OF

GASHOLDERS,

Single or Telescopic, with Cast or Wrought Iron Guide Frames.

HOLDERS BUILT SINCE 1881:

Scranton, Pa. (2d)
West Point, N. Y.
Fitchburg, Mass.
New London, Conn.
Derby, Conn.
Bridgeport, Conn.
Allegheny, Pa. (1st.)
St. Hyacinth, Can.
Norwalk, O.
Brattleboro, V.
Waltham, Mass. (2d.)
West Chester, Pa.
Baltimore, Md.

Holidaysburg, Pa.
Galveston, Texas (2d.)
Marlboro, Mass.
Denver, Col.
Chicago, Ill. (West Side).
Pittsburgh, Pa. (S. Side).
Pawtucket, R. I.
Brookline, Mass.
Sherbrooke, Can.
Burlington, N. J. (2d.)
Bridgeton, N. J.
Bay City, Mich.
Erie, Pa.

Jackson, Mich.
Kalamazoo, Mich. (3d.)
Glen Island, N. Y.
Warren, Ohio.
Bath, N. Y.
Lynn, Mass.
New Bedford, Mass.
Waterbury, CONE.
Deseronto, Can.
Hoosic Falls, N. Y. (2d.)
Bethlehem, Pa.
Atlanta, Ga. (1st.)
Savannah, Ga.

Montgomery, Ala.
Newport, R. I.
Portland, Oregon.
Allegheny, Pa. (2d.)
Atlanta, Ga. (2d.)
N.Y. City (Central Gas Co)
Lynchburg, Va. (2d.)
Saylesville, R. I.
Rondout, N. Y.
Atlantic City, N. J.
Augusta, Ga.
Waltham, Mass. (2d.)
Mahanoy City, Pa.

New Castle, Pa.
Long Island City, N. Y.
Macon, Ga.
York, Pa.
Chester, Pa.
Hazleton, Pa. 2d.)
Novelties Exhib., Phila.
Staten Island, N. Y.
Saugerties, N. Y.
Clinton, Mass. (Lan. M)
Chattanooga, Tenn.
Galveston, Texas. (3d.)
Omaha, Neb.

GAS COALS.

GAS ENRICHERS.

EXHAUSTERS.

JAMES D. PERKINS.

PERKINS & CO.,

F. SEAVERNS.

General Sales Agents for

The Youghioghenny River Coal Company's**OCEAN MINE YOUGHIOGHENY GAS COAL.**

The Coal from the Ocean Mine (recently operated by Messrs. W. L. Scott & Co., of Erie, Pa.,) is now used by all the leading Gas Companies in the United States from Maine to Texas, and is recognized as *the only reliable Youghioghenny Gas Coal.* (See Map on p. 87 of this Journal, Feb. 16, 1885.)

P. O. Box 3695,
New York.**PERKINS & CO., 228 and 229 N. Y. Produce Exchange.**BEAVER STREET
ENTRANCE.**BRECKENRIDGE CANNEL,
OF KENTUCKY.**

This colliery was re-opened in June of the present year, and the Cannel is now being delivered to thirty of the leading Gas Companies in this country. As an enricher ONE TON of this Cannel will do the work of two TONS of any other available Cannel. It can be delivered in parcels of one car load or more to any point in the United States or Canada. (See AMERICAN GAS LIGHT JOURNAL, June 16, '86, pp. 346-7.)

P. O. Box 3695,
New York.**PERKINS & CO., 228 and 229 N. Y. Produce Exchange**BEAVER STREET
ENTRANCE.**JAMES & WILLIAM WOOD,
Gas and Cannel Coal Contractors,**

No. 40 St. Enoch Sq., Glasgow. No. 2 Talbot Court, London.

Proprietors of the **BATHVILLE COLLIERIES** (which produce the celebrated **BOGHEAD CANNEL**), Shields, Shieldmuir, Drumpeller, and other Collieries. This Firm offer

STANDARD CANNELS,**Unequaled as Gas Enrichers.**

Analyses, prices, and all further information furnished on application to

Agency for U. S., Room 93, Nos. 2 & 4 Stone St., N. Y. City.O. J. BENHAM,
President.C. M. HIGGINS,
Secretary.L. H. SEVERANCE,
Treasurer.**The Forest City Naptha Co.,**

REFINERS OF

Red Crown Brand**NAPTHA AND GASOLINES.**

ALSO MANUFACTURERS OF

**A Special Grade of Naptha for
Gas Companies****FOR ENRICHING COAL GAS.**

Correspondence solicited.

No. 43 Euclid Avenue, Cleveland, Ohio.

To Gas Companies.We make to order **CAP BURNERS** to burn any amount under a stated pressure. Send for samples.Also, **SERVICE CLEANERS, DRIP PUMPS, and STREET MAIN PROVING APPARATUS.****C. A. GEFRORER,**

248 N. 8th Street, Phila., Pa.

The Wilbraham Gas Exhauster,**"BAKER SYSTEM,"**

WITH ENGINE ATTACHED, ON SAME BED PLATE OR WITHOUT.

Best, Cheapest and Most Durable Exhauster known.**WILBRAHAM BROS.,**

No. 2320 Frankford Avenue, Philadelphia, Pa.

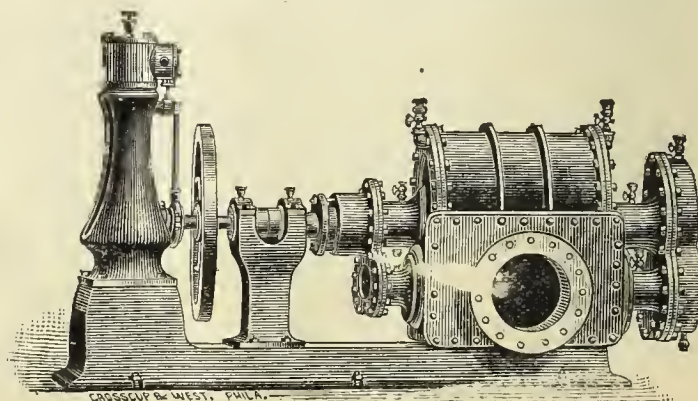

COKE CRUSHERS.

GAS COALS.

GAS COALS.

Newburgh Orrel Coal Co.,

MINERS AND SHIPPERS OF

Mountain Brook Steam and Smithing Coals,

AURORA, TYRCONNELL & PALATINE GAS COALS.

Foundry & Crushed Coke Shipped Direct from Ovens

Mines Situated at

Newburgh, Flemington & Fairmont, W.Va.

HOME OFFICE,

33 S. Gay St., Baltimore.

CHAS. MACKALL, Gen. Mangr.

CHAS. W. HAYS, Agent in New York,

Room 147, WASHINGTON BUILDING, No. 1 Broadway.

Shipping wharves at Locust Point, Baltimore.

THE DESPARD COAL COMPANY

OFFER THEIR SUPERIOR

DESPARD COAL

To Gas Light Companies and Manufacturers of Fire Clay Goods Throughout the Country.

ROUSSEL & HICKS, } AGENTS. { BANGS & HORTON, }
71 Broadway, N. Y. } 16 Kilby St., Boston.

Mines in Harrison Co., West Va. Wharves, Locust Point, Balt.

Company's Office, 15 German St., Baltimore, Md.

Among the consumers of Despard Coal we name: Manhattan Gas Light Co., N. Y.; Metropolitan Gas Light Co., N. Y.; Jersey City, (N. J.) Gas Light Co.; Washington (D. C.) Gas Light Co.; Portland (Maine) Gas Light Co. Reference to them is requested.

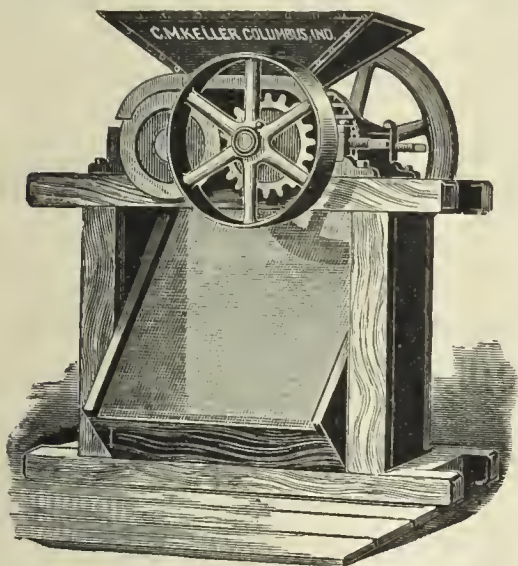

Keller's Adjustable Coke Crusher.

SIMPLE, STRONG, AND DURABLE.

C. M. Keller, Sec. & Supt. Gas Lt. & Coke Co. Columbus, Ind.

Correspondence Solicited.

GAS COMPANIES, ATTENTION!

Increase the demand for Coke by using the

Star Coke Breaker.

SIMPLE, CHEAP, DURABLE. EASILY SHARPENED BY ANY BLACKSMITH.

B. J. ALLEN, Newark Gas Co., Newark, N.J.

King's Treatise on Coal Gas.

The most complete work on Coal Gas ever published

Three Vols. Bound, \$30.

A. M. CALLENDER & CO., 42 Pine St., N. Y.

THE PENN GAS COAL CO.

OFFER THEIR

Coal, Carefully Screened & Prepared for Gas Purposes.

Their Property is located in the Youghiogheny Coal Basin, near Irwin and Penn Stations on the Pennsylvania Railroad, and on the Youghiogheny River.

Principal Office:

209 SOUTH THIRD STREET, PHILA., PA.

Points of Shipment:

Pennsylvania Railroad Piers; Greenwich Wharves, Delaware River; Pier No. 1 (Lower Side), South Amboy, N. J.

Chesapeake & Ohio Railway Coal Agency,

FOR THE SALE OF THE

Superior Kanawha Gas Coals, Cannelton Cannel, Also, SPLINT AND STEAM COALS,

From the Kanawha and New River Regions, on the line of the Chesapeake & Ohio R'way.

C. B. ORCUTT, Sales Agent. | OFFICE, 150 BROADWAY, N. Y.

FRANCIS H. JACKSON, Prest. EDMUND H. MCCULLOUGH, V.-Prest. CHAS. F. GODSHALL, Treas. H. C. ADAMS, Sec.

THE WESTMORELAND COAL CO.

Chartered 1854.

Mines situated on the Pennsylvania and the Baltimore and Ohio Railroads, in Westmoreland County, Penn.

POINTS OF SHIPMENT:

PHILADELPHIA, BALTIMORE, SOUTH AMBOY, N. J., WATKINS (SENECA LAKE), N. Y.

Since the commencement of operations by this Company its well-known Coal has been largely used by the Gas Companies of New England and the Middle States, and its character is established as having no superior in gas-giving qualities, and in freedom from sulphur and other impurities.

Principal Office, 224 South 3d St., Phila., Pa.

A. M. SCOTT, PRESIDENT. A. DEMPSTER, C.E., SECRETARY. W. K. GILLESPIE, TREASURER.

MONONGAHELA AND PETERS CREEK GAS COAL CO.,

PRODUCERS OF

Coal Bluff Gas Coal.

MINES LOCATED ON THE MONONGAHELA DIVISION OF THE PENNSYLVANIA RR., IN THE CENTRAL PORTION OF THE PITTSBURGH COAL FIELD.

Points of Shipment—Buffalo, Cleveland, Erie, Chicago, New Orleans.

Since the introduction of Coal Bluff Gas Coal it has taken rank among the few first-class Gas Coals, and acknowledges no superior in gas-giving qualities, ease of working, quality of coke, and freedom from impurities.

General Eastern Agents, ANDREW LANGDON & CO., Buffalo, N. Y.
General Western Agents, ANDREW LANGDON & CO., Chicago, Ill.
Milwaukee Agents, F. R. BUELL & CO., Milwaukee, Wis.

General Office, 43 Sixth Ave., Pittsburgh, Pa.

GAS METERS.

GAS METERS.

GAS METERS.



INTERNATIONAL--1876--EXHIBITION.

The U. S. Centennial Commission

HAVE DECREED AN AWARD TO

HARRIS, GRIFFIN & CO.,

Twelfth and Brown Streets, Philadelphia, Pa. No. 49 Dey Street, N. Y. City, and No. 75 North Clinton Street, Chicago, Ill.

FOR THE FOLLOWING REASONS:

The Exhibit consists of a Series of METERS from the Largest Size Station Meters for the use of the MANUFACTURE OF GAS, to those for the use of the ORDINARY CONSUMER. The Instruments are WELL MADE, RELIABLE as to INDICATION, and embody a number of sundry improvements which, with the general character of the Exhibit, entitle the whole to commendation.

Attest—J. L. CAMPBELL,
Secretary, pro-tem.

Signed—A. T. GOSHORN,
Director General

J. R. HAWLEY,
President

CHARLES E. DICKEY.

JAMES B. SMALLWOOD.

CHARLES H. DICKEY.

Maryland Meter and Manufacturing Co.,

DICKEY, TANSLEY & CO.,

Established 1866.

Nos. 22 and 24 Saratoga Street, Baltimore, Md.

No. 46 La Salle St., Chicago, Ill.

MANUFACTURERS OF

DRY GAS METERS, STATION METERS, GLAZED METERS, TEST METERS, METER PROVERS, PRESSURE AND VACUUM REGISTERS, GOVERNORS, INDICATORS, SERVICE AND METER COCKS, AND METER CONNECTIONS.

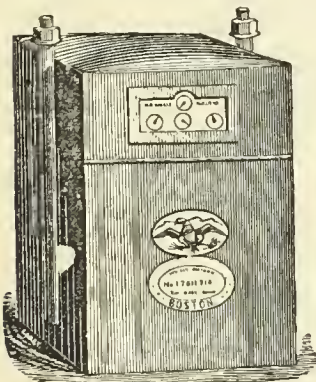

Dry Gas Meter.

With 39 years' experience and the best facilities for manufacturing, is enabled to furnish reliable work and answer orders promptly.

NATHANIEL TUFTS,

No. 153 Franklin Street, Boston, Mass.,

MANUFACTURER OF

DRY GAS METERS.

Station Meters of any Capacity.

Test and Experimental Meters, Pressure Registers, Pressure Gauges,
Pressure and Vacuum Gauges.

METER PROVERS, PHOTOMETERS, STREET LANTERNS, ETC., ETC.

Patent Cluster Lanterns for Street Illumination.

SCIENTIFIC BOOKS.

We are prepared to furnish to Gas Managers, and others interested in the topics treated of, the following books, at prices named:

KING'S TREATISE ON THE MANUFACTURE OF COAL GAS. Three vols.; \$10 per vol.
GAS MANUFACTURE, by WILLIAM RICHARDS. 4to., with numerous Engravings and Plates, in Cloth binding. \$12.
THE GAS ANALYST'S MANUAL, by F. W. HARTLEY. \$2.50.
TECHNICAL GAS ANALYSIS. \$2.80.
GAS MANAGER'S HANDBOOK, by THOS. NEWBIGGING. \$4.80.
GAS CONSUMER'S GUIDE. \$1.
A GUIDE TO GAS LIGHTING. 40 cents.
GAS MEASUREMENT AND GAS METER TESTING, by F. W. HARTLEY. \$1.60
GAS CONSUMER'S HANDBOOK, by WILLIAM RICHARDS, C.E.; 18mo., Sewed. 20 cents.

PURIFICATION OF COAL GAS, by R. P. SPICE. 8vo. \$3.
PRACTICAL TREATISE ON HEAT, by THOMAS BOX. Second edition. \$5.
GAS WORKS—THEIR ARRANGEMENT, CONSTRUCTION, PLANT, AND MACHINERY. \$8.
COAL; ITS HISTORY AND USE, by PROF. THORPE. \$3.50.
THE GAS WORKS OF LONDON, by COLBURN. 60 cents.
THE GAS FITTER'S GUIDE, Showing the Principles and Practice of Lighting with Coal Gas, by JOHN ELDRIDGE. 40 cents.
GAS WORKS, AND MANUFACTURING COAL GAS, HUGHES. \$2.20.
THE MANAGEMENT OF SMALL GAS WORKS, by C. J. R. HUMPHREYS. \$1.
MANUAL FOR GAS ENGINEERING STUDENTS, by D. LEE, 40 cents.

A PRACTICAL TREATISE ON GAS AND VENTILATION with Special Relation to Illuminating, Heating, and Cooking by Gas, by E. E. PERKINS. \$1.25.
HOW TO MANAGE GAS, by F. WILKINS. Paper. 20 cents.
THE GAS MANAGER IN THE LABORATORY, by a Practical Student. 8vo., Cloth. \$1.50.
THE DOMESTIC USES OF COAL GAS, AS APPLIED TO LIGHTING, by W. SUGG. \$1.40.
DISTILLATION OF COAL TAR AND AMMONIACAL LIQUOR, by GEO. LUNGE. \$8.50.
A TREATISE ON THE COMPARATIVE COMMERCIAL VALUES OF GAS COALS AND CANNELS, by D. A. GRAHAM 8vo., Cloth. \$3.
GAS AS A SOURCE OF LIGHT, HEAT, AND POWER, by C. J. R. HUMPHREYS. 10 cents.
GAS COMPANIES DIRECTORY. \$10.
GAS VERSUS ELECTRIC LIGHT. 50 cents.

The above will be forwarded by express, upon receipt of price. We take especial pains in securing and forwarding any other Works that may be desired, upon receipt of order. All remittances should be made by check draft, or post office money order.

A. M. CALLENDER & CO., No. 42 Pine Street, New York.

GAS METERS.

GAS METERS.

GAS METERS.

T. C. HOPPER, Pres.

G. J. MCGOURKEY, Vice-Pres. (New York).

WM. N. MILSTED, Gen. Supt. & Treas. (New York).

WM. H. DOWN Sec.

AMERICAN METER COMPANY,

WET AND DRY GAS METERS.

PRESSURE REGISTERS.

METER PROVERS.

STATION METERS.

PRESSURE & VACUUM REGISTERS.

PORTABLE TEST METERS.

EXHAUSTER GOVERNORS.

PRESSURE & VACUUM GAUGES.

EXPERIMENTAL METERS.

DRY CENTRE VALVES.

CRESSON GAS REGULATORS.

AMMONIA TEST METERS.

GOVERNORS FOR GAS WORKS.

MARSLAND WATER METERS.

BAR AND JET PHOTOMETERS.

Manufactories:

512 W. 22d St., N. Y.

Arch & 22d Sts., Phila.

GAS STOVES,

SUGG'S "STANDARD" ARGAND BURNERS,

SUGG'S ILLUMINATING POWER METER,

Wet Meters, with Lizar's "Invariable Measuring" Drum.

Agencies:

177 Elm Street, Cincinnati.

214 & 216 N. Wells Street, Chicago.

810 North Second Street, St. Louis.

122 & 124 Sutter St., San Francisco

HELME & McILHENNY,

(Successors to Harris & Brother. Established 1848.)

GAS METER MANUFACTURERS,

CONTINUE AS HERETOFORE AT THE OLD ESTABLISHMENT,

Nos. 1339 to 1349 Cherry Street, Philadelphia, Pa.,

To Manufacture Wet and Dry Gas Meters, Station Meters, Experimental Meters, Meter Provers, Center Seals, Pressure Registers,

GOVERNORS, INDICATORS, PHOTOMETERS, & ALL OTHER KINDS OF APPARATUS FOR USE IN GAS WORKS.

From our long practical experience of the business, and from our personal supervision of all work, we can guarantee all orders to be executed promptly, and in every respect satisfactorily.

WM. WALLACE GOODWIN, Prest. and Treas.

WM. H. MERRICK, V.-Prest.

S. L. JONES, Sec.

S. V. MERRICK, Supt.

THE GOODWIN GAS STOVE AND METER COMPANY,

Successors to W. W. GOODWIN & CO.

1012, 1014 and 1016 Filbert St., Phila., Pa.

142 Chambers St., New York.

76 Dearborn St., Chicago, Ill.

WALDO BROS., Agents, 88 Water St., Boston.

MANUFACTURERS OF THE "SUN DIAL" GAS STOVES, FOR COOKING AND HEATING PURPOSES.

Dry and Wet GAS METERS, Station Meters (Square, Cylindrical or in Staves) Glazed Meters, King's and Sugg's Experimental Meters, Lamp Post Meters, Etc., Etc., Meter Provers (sizes 2, 5 and 10 feet), Pressure Gauges of all kinds, Pressure Registers, Pressure and Vacuum Registers, Pressure Indicators (sizes 4 inch, 6 inch and 9 inch), King's Pressure and Vacuum Gauges, Dry and Wet Centre Seals, Dry and Wet Governors, Exhauster Governors, Photometers of all descriptions. Letheby's Sulphur and Ammonia Test Apparatus complete—also Testing and Chemical Apparatus of all kinds, and of the most perfect description, for all purposes relating to Gas.

GOODWIN'S IMPROVED LOWE'S JET PHOTOMETER.

Agents for Bray's Patent Gas Burners and Lanterns.

Special attention to repairs of Meters, and all apparatus connected with the business.

All work guaranteed first class in every particular, and orders filled promptly.

G. B. EDWARDS, Mang'r, New York.

E. H. B. TWINING, Mang'r, Chicago.

Represented by A. B. STANNARD.

D. McDONALD & CO.,

GAS METER MANUFACTURERS.

(Established 1854.)

51 Lancaster St., Albany, N. Y. 34 & 36 West Monroe St., Chicago, Ill.

STATION METERS, EXPERIMENTAL METERS, METER PROVERS, PRESSURE & VACUUM REGISTERS, PRESSURE GAUGES, ETC.

Also STAR GAS STOVES, RANGES, and HEATING STOVES.

We use only the very best materials, and employ the most skilled labor, and by our long experience (29 years) and personal supervision of every detail, we feel justified in assuring the public that our goods will give perfect satisfaction. Every Meter emanating from our establishment will bear the State Inspector's BADGE, and will be fully warranted by us. Our Annual and Calendar will be sent to Gas Companies upon application.

KINC'S TREATISE ON COAL GAS.

The most complete work on Coal Gas ever published. Three vols., bound \$30

A. M. CALLENDER & CO., No. 42 Pine Street, New York.

GAS STOVES.

GAS STOVES.

GAS STOVES.

THE GOODWIN GAS STOVE AND METER CO.,

1012-18 Filbert St., Phila., 142 Chambers St., N. Y., 76 Dearborn St., Chicago.

Agents, WALDO BROTHERS, 88 Water Street, Boston.

WM. W. GOODWIN, PRES. & TREAS.
W. H. MERRICK, VICE-PRES.
S. LEWIS JONES, SEC.
SAMUEL V. MERRICK, SUPT.

SOLE MANUFACTURERS OF THE

G. B. EDWARDS, Mang'r, N. Y.
E. H. B. TWINING, Mang'r, Chicago.
Represented by A. B. STANNARD.

"SUN DIAL" GAS STOVES

The Most Economical, Efficient, and Durable Gas Stove Made.

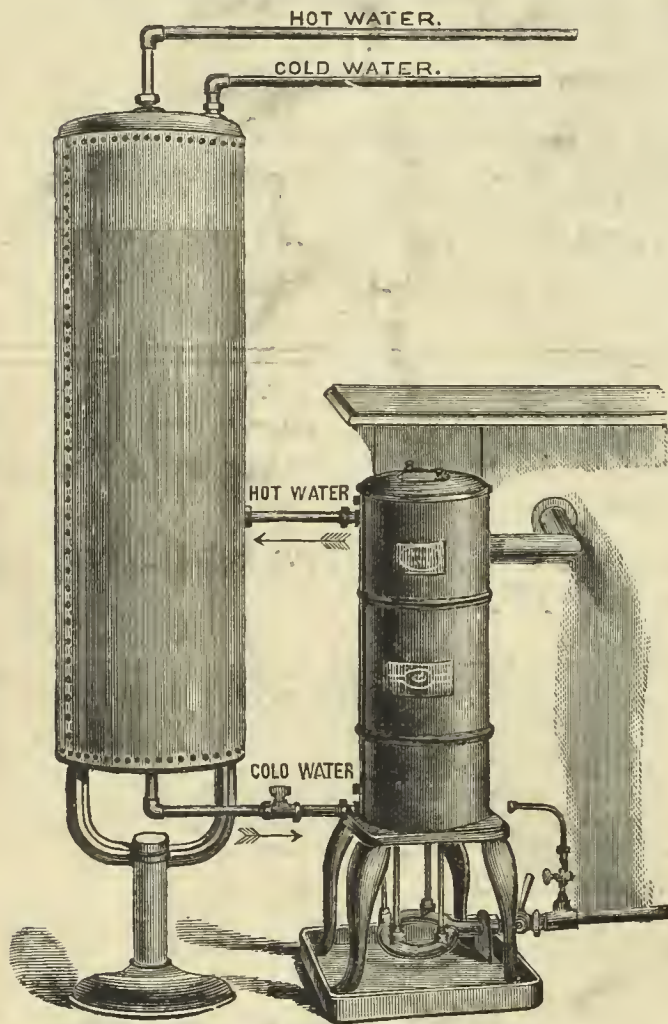

I.—Safety Hot Water Generator and Boiler.

Safety Hot Water Generator and Boiler.

Cut I. represents our Safety Gas Hot Water Generator and Boiler, arranged for home use. This most easy, quick, and economical way of preparing a warm bath, or for heating water for any domestic purpose, entirely supersedes any necessity for the use of ranges or stoves—a great comfort, particularly in hot weather. The boiler being self-filling, as the hot water is drawn off, can never become empty, thus preventing the possibility of any accident.

We beg to call attention to the cast iron pan which is now attached to the legs of the Generator (see illustration). This is to catch the drippings from the Coil, which many persons suppose come from a leak, when in fact they are produced by condensation. This condensation is caused by the hot flame coming in contact with the coil filled with cold water.

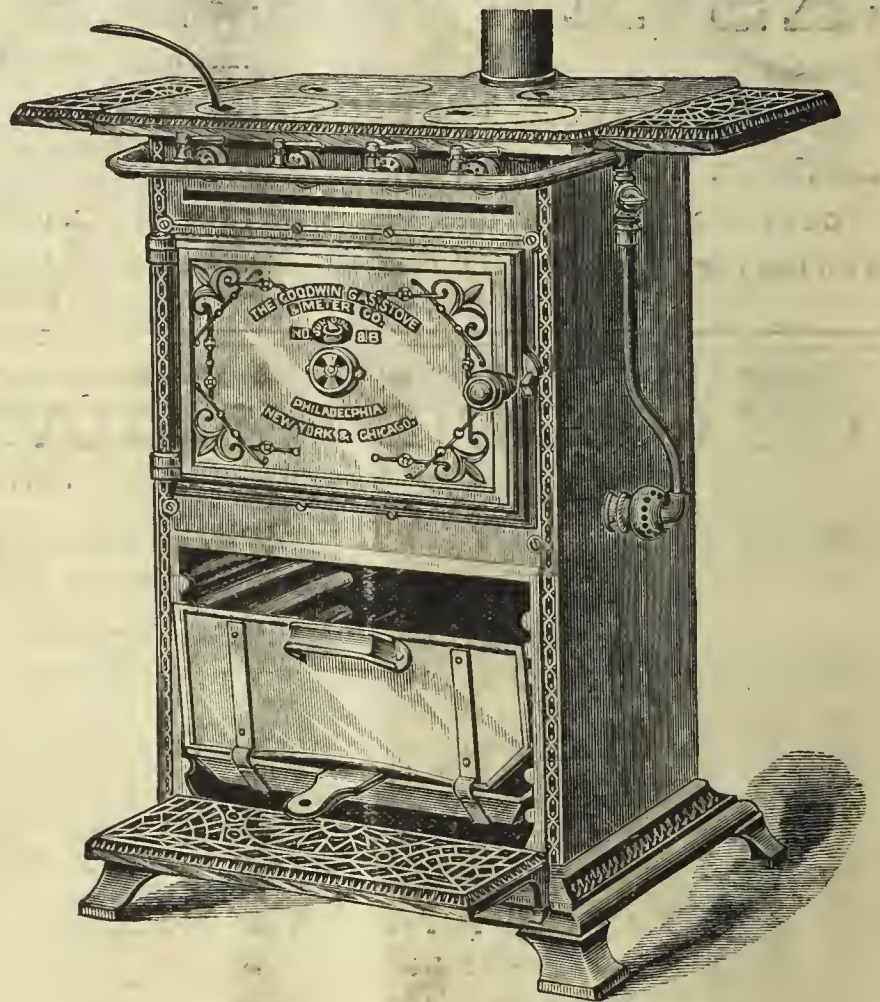

II.—Gas Cooking Stove No. 8 B.

New Style Gas Cooking Stove.

Cut II. represents our New Style Cooking Stove. As will be seen, it has an ornamented cast iron base and front, and extension shelves. The oven burner, which is atmospheric (unless otherwise ordered), is of an entirely new and improved pattern (patent applied for). The ovens are of greater capacity than those of the old style. The top, in conjunction with the outlet pipe, is designed to carry off all products of combustion; hence the outlet pipe must be connected with a flue, or the stove will not work properly.

This Stove has 4 boiling burners in top of hot plate. All fittings are nickel plated. We are making this style of Cooking Stove in the following sizes—viz., No. 7 B, No. 8 B, No. 9 B, and No. 10 B.

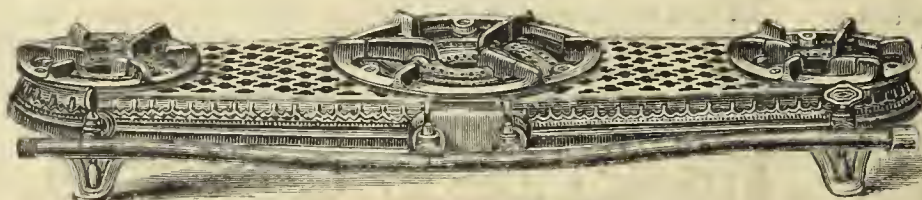

III.—Improved Hot Plate, No. 108.

New Style Hot Plates.

Cut III. represents our New Style of Hot Plates, of which we are making No. 106 (two small boiling burners), No. 107 (two medium sized boiling burners), and No. 108 (two medium and one large boiling burner). See new Catalogue and Price List for further particulars.

THE AMERICAN

GAS LIGHT JOURNAL

REDMAN & KENNY, N. Y.

PUBLISHING OFFICE NO. 42 PINE STREET

DEVOTED TO THE INTERESTS OF ILLUMINATION, VENTILATION, WATER SUPPLY AND DISTRIBUTION, & GENERAL SCIENCE.

VOLUME XLVI.—No. 2. }
Whole No. 662.

NEW YORK, MONDAY, JANUARY 17, 1887.

{ \$3 PER ANNUM,
IN ADVANCE.

A. M. CALLENDER & CO., Proprietors. C. E. SANDERSON, Manager.
JOS. R. THOMAS, C. E., Editor. T. J. CUNNINGHAM, Asst. Editor.

ENTERED AT THE POST OFFICE AT NEW YORK, N. Y.
AS SECOND CLASS MATTER.

CONTENTS.

An Asterisk (*) denotes an illustrated article.

OFFICIAL NOTICE—
Annual Meeting of the New England Association..... 33

OFFICIAL CIRCULAR—
Ohio Gas Light Association..... 33

EDITORIALS—
Annual Meeting Society of Gas Lighting..... 33
After a Famine We are Treated to a Feast..... 33
Fourteenth Annual Meeting of the American Gas Light Association
—Official Report—Concluded from page 9..... 34
An Experiment with Limed Coal, by Walton Clark—Discussion—Comparisons on Cost of Gas, Electric Light and Oil, by E. Stein—Amendment to the Constitution—Some Suggestions on Paper Writing, by J. H. Armington—Discussion—Electric Lighting, by C. F. Spaulding—Discussion—The Question-Box—“How can the demand for tar be increased?”—Mr. Turner, on Earthquakes—Uniformity of Meter Connections—Proposed Formation of an Association for Pennsylvania—Votes of Thanks.
A Supplement to the Chapter on Practical Gas Making, by Fred. Egner..... 40
Lecture on Natural Gas..... 40
Naphtha as an Enricher, by A. S..... 41
The Gas Companies and the State..... 42
Experiments on Flame..... 42
Useful Hints for Steam Users..... 43

ITEMS OF INTEREST FROM VARIOUS LOCALITIES..... 43
Personal—Gas Rates at Columbia, Pa.—Washington (Pa.) also in Line—The Finance Committee of Philadelphia City Council Says “No.”—Named as Chief Engineer—Brother Egner and His Varying Emotions—Cheaper Gas for Kingston, Canada—Judge Moran Hands Down a Decision—A Burner Company—An Item from Lincoln, Ills.—Something from Ironton, Ohio—Change in Firm Name—At Rest—One Day’s Sendout at Poughkeepsie, N. Y.—New Gas Company—Holder for the Long Branch (N. J.) Gas Company—Mr. Glenn, of Cincinnati, Ohio—Frisky Natural Gas—The Brooklyn (N. Y.) Electric Light Controllers—Going Ahead—Price of Gas at Brunswick, Ga.—Street Lighting at Bayonne, N. J.—To Abandon Water Gas—Gas Companies Bidding for What is Left—To Compel a Reduction—To Light Their Roadway—Proposal to Establish a Gas Works—Eaton’s Experience—Address Changed—American Society of Civil Engineers—What Collector Magone Thinks of the Electric Light—To Build the Lowell (Mass.) Holder—Named as General Manager—Secretary Butterworth’s List.
The Market for Gas Securities..... 46

[OFFICIAL CIRCULAR.]

Ohio Gas Light Association.

OFFICE OF SECRETARY, COLUMBUS, OHIO, Jan. 10, 1887.

To the Members of the Association:—Now that the busy holiday season is over, all members of this Association, and others who expect to become members or attend our sessions, will, it is hoped, have time to devote some thought to the forthcoming Third Annual Meeting, which will be held in Dayton, Ohio, commencing on the third Wednesday of March, 1887, and lasting two days.

Two requisites, which it is the object of this circular to help secure, are essential to a profitable meeting, viz: a good attendance, and a sufficient number of papers to be read and discussed. As a stimulus to a good attendance, and to add interest to the meeting, as well as to obtain the best views of the gas men of the State upon a vexed subject, the President of the Association offers a reward of \$25 for the best, and \$10 for the second best, paper upon the following subject, the only condition being that there shall be not less than three papers presented thereon: “How Shall We Get Rid of Naphthaline Crystals About the Works, and Still Maintain High Heats?”

Papers have already been promised upon the following subjects: “Gas and Electricity—Two Interests or One?” “Tar as an Enricher;” “Gas Commissions;” and “A Regenerative Furnace Adapted to a Small Works.” The following subjects have also been proposed, and members and others are *urgently requested to volunteer* papers thereon, notifying the Secretary at once. [The list will be found at close of page 45.]

Let every gas man in the State not only make his arrangements to attend our Dayton meeting, but also, if not willing to present a paper, at least be prepared to participate in the discussion of the subjects named.

IRVIN BUTTERWORTH, Sec’y.

ANNUAL MEETING SOCIETY OF GAS LIGHTING.

At the last annual meeting of the Society the time of the sessions was chiefly absorbed in the transaction of routine business. The address of the President was devoted to an oral *resume* of the progress of the past year, and in congratulating the Society upon its sturdy adherence to the principles that caused its formation. The ballot for officers resulted in the re-election of those who served in the past twelvemonth. The assignment for papers to be read at the assemblies of 1887 resulted in the following allotment: *Jan.*—M. S. Greenough and J. R. Thomas; *Feb.*—C. J. R. Humphreys and F. A. Sabbaton; *March*—C. H. Nettleton and C. H. Coggshall; *April*—D. D. Flemming and O. E. Cushing; *May*—W. Farmer and Wm. Coombs; *June*—W. A. Stedman and W. Mooney; *Sept.*—A. M. Smith and F. C. Sherman; *Oct.*—A. Strecker and E. Vanderpool; *Nov.*—A. B. Slater and J. H. Armington. The annual banquet was heartily enjoyed, and it goes without saying that the Society of Gas Lighting is in thorough good shape to grapple with the happenings of the ensuing twelvemonth.

AFTER A FAMINE WE ARE TREATED TO A FEAST.

Possibly we may be forgiven for having, in the exuberance of feeling that resulted from such an hitherto unheard or unseen state of affairs, sought to epitomize, in the above headline, our exact state of mind when it came to pass that a most wonderful “conjunction” had occurred. To express it in

[OFFICIAL NOTICE.]
Annual Meeting of the New England Association.
To the Members of the New England Association of Gas Engineers:—The Annual Meeting of this Association will be held at Young’s Hotel, in Boston, Mass., on February 16 and 17, 1887. The meeting will be called to order at 10 o’clock on Wednesday morning, and it is hoped that there will be a large attendance at that time. Papers have been promised by the following members: C. J. R. Humphreys—“Some Thoughts on Purification by Oxide.” A. M. Norton—“Effects of Reduction in the Price of Gas.” C. F. Prichard—“Candle Power and Illumination.” R. B. Taber—“Some Photometrical Experiments.” It is confidently expected that, in the next issue of the JOURNAL, other papers will be announced. The coming meeting will, from the above papers and their authors alone, certainly be very interesting. Any member having some question which he would like answered, or some subject he would like discussed, if he will notify the Secretary, before February first, of his wishes, a copy of the same will be mailed immediately to each member, so that all may come prepared to take part in the discussion.

CHARLES H. NETTLETON, Sec’y.

a slightly different way, and perhaps in a manner more easily understood, no wonder that surprise should be created when a leading technical paper—not devoted to the interests of the gas maker—comes out and editorially acknowledges, as the *Iron Age* folks acknowledged in a recent issue, that what was done and said at the late Philadelphia meeting, in respect of the paper on gas commissions there presented by Mr. Geo. G. Ramsdell, was in the nature of a revelation to its proprietors. The revelation, of course, being greatly to the credit of the gas men, in that the *Iron Age* apparently half confessedly admits that the previous history of gas companies in this country was anything but favorable to their proprietors. Leaving the *Iron Age* aside for the moment we come to the next and final (for the present at least) cause for surprise, which we find concealed or revealed in the message of that astute politician and remarkably successful leader of men, the Governor of the Empire State. Not that we find much that will positively commit Governor Hill to the support of a State Gas Commission in his allusions thereto in the document under consideration; but sufficient reason for wonder is afforded at the mere discovery that he should find it necessary to refer to the subject at all. Indeed the Governor may be fairly said to beg the question, but perhaps that is as far as a professional politician may safely go. Taking the Governor's gingerly way of handling the topic as evidence that he is inclined to pay some measure of attention to the abuses that the present capital amounts invested in gas undertakings in this State are subject to, we can assure him that our gas makers are not only inclined but ready to take him at his word. This is what he says: "It is suggested that the public demand for the correction of any abuses which may still exist, and which have not already been entirely remedied, may be met by the passage of a measure, not local in its character, but providing for the appointment of a State Commission, with power, under reasonable restrictions, to regulate and control the management of all gas companies throughout the State; to investigate all overcharges and other complaints; to report its investigations to the Legislature, and, in general, to possess over gas companies powers somewhat similar to those which the Railroad Commission of the State has over railroad companies; such commission to be maintained without cost to the State, but at the expense of the gas companies in a manner analogous to that in which the Insurance Department and the Railroad Commission are now supported." We accused the Governor of handling the subject gingerly, but the accusation could not have been urged did he employ the words, "I recommend," etc., instead of "It is suggested," etc. The "suggestions" are almost identical with those that have been urged by the gas makers of this and other States for at least twelve years back, and had they been acted upon in something like half-season, gas would now be selling in New York city at a less figure than that forced upon the companies by the legislation, unconstitutional and revengeful enough for the most reckless of its framers, of last spring. However, since the half of a loaf is better than no bread, perhaps the present session at Albany may witness a partial repair of the recklessness and savagery of the past. If Governor Hill is honest in what we may term his "present suggestions," and desires to help the gas consumers by protecting the gas manufacturers, we can assure him that the manufacturers will interpose no obstacle to the scheme "suggested." Assure them of the appointment of honest, incorruptible men to the commissionerships—and this can be best done by making their compensation sufficiently large—and the gas makers will be satisfied. Nevertheless, talk is cheap, and "suggestions" do not come at a high figure, either; furthermore, we cannot fail to remember that without the aid of Governor Hill the incongruous and punitory legislation before alluded to could never have attained true legal significance or import. And that legislation was incongruous, for instance, because it compelled the Central Company, which certainly does not supply over 2,000 consumers, to supply gas at a price equal to that paid to the Consolidated Company, by its thousands of customers; punitive, because the Companies of the metropolis would no longer submit to be blackmailed.

To come back to the *Iron Age* (the article therefrom appears in full elsewhere in our columns), we cannot, in the main, say much against the sentiments of its commentary. To the credit of its owners be it said, they have always shown a desire to be on the side of fairness and honesty in the agitation and discussion of questions that come within its province as the disseminator and upholder of knowledge at once truthful and exact. But we would remind our contemporary, having first thanked it for an outspoken opinion, that the consentient feeling on the subject of gas commissions on the part of the gas fraternity, displayed at the Philadelphia meeting of the American Gas Light Association, dates not from the occasion of that gathering. The feeling may have received sharp accentuation then, but it had been entertained and expressed many years ago, in proof whereof we submit in evidence the columns of this JOURNAL. Truly, though, between the *Iron Age's* comments and Governor Hill's message, we have cause for hope that those who were our enemies may yet become our allies. In the meantime it should be remembered that Massachusetts has a Gas Commission, while New York and her sister States are without such bodies.

[OFFICIAL REPORT.—Concluded from page 9.]

Fourteenth Annual Meeting of the American Gas Light Association.

HELD AT THE ACADEMY OF MUSIC, PHILA., PA., OCT. 20, 21, AND 22, 1886.

SECOND DAY—THURSDAY, OCT. 21—AFTERNOON SESSION.

The President introduced Mr. Walton Clark, of New Orleans, La., who read the following paper on

AN EXPERIMENT WITH LIMED COAL.

During the past season an opportunity for testing practically the effect of mixing lime with Pittsburgh coal before carbonization offered at the Jefferson City (La.) gas works. I availed myself of it, and for 25 days all the gas produced at the above works was from limed coal.

The experiment was expected to answer the following questions, relative to liming such coal as we use: What is the effect on the absolute amount of ammonia produced? On the sulphuretted hydrogen and carbonic acid in the crude gas? On the total sulphur in commercial gas? On purification, yield, and illuminating power?

The answers were apparently positive; and my desire is to present them with such details of the experiment as will enable each to judge of their value for himself.

One bench of retorts makes all the gas at our works in the summer months, and we have no plant for the manufacture of sulphate of ammonia. Purification is effected by means of Laming's mixture. The gas, leaving the hydraulic main, passes through 65 feet of 8-inch pipe to the exhauster, thence at once through a Pelouze & Audouin condenser and a vertical air condenser, of capacity sufficient to reduce the gas to atmospheric temperatures, and into the scrubber—a cylinder 20 ft. by 48 in., charged with coke. A set of four purifiers, having an area of 36 sq. ft. each, completes the producing and purifying plant. All the liquor and tar flow together to the tar tank. During the experiment a separator sent the tar to one tank and the liquor to another. As the liquor tank filled up the liquor was measured, sampled, and run to the drain.

Our first care was to so mix the coal and lime as to prevent loss in dust during charging. A few trials settled that point. The lime was slaked with its own weight of water and allowed to cool. Just before mixing with the coal 100 per cent. more water was added and the lime thrown over the coal, which was then turned once and loaded into the barrows. After 25 days' working there was no indication, away from the immediate vicinity of the lime box, that anything unusual had been going on. All the lime went into the retorts. Before charging, the limed coal was often thoroughly dried by the heat from the front of the bench. The coal was broken finer during the first ten days of the experiment than is usual with us. Afterward it was of the ordinary size. With coal broken very fine—almost slack—we obtained our best results in ammonia. I intended to use 3 per cent. of lime, but found at the end of the experiment that I had only used 2.7 per cent. This amount of pure calcic oxide is sufficient to fix as sulphide all the sulphur in the coal (1.13 per cent.), if the mixture were perfect and the conditions favorable.

With unlimed coal our total yield of ammonia per 2,240 lbs. was 5.3 lbs.—equal to 20.5 lbs. chemically pure sulphate, or 21.9 lbs. commercial (24 per cent.) salt.

With limed coal the yield was 7.4 lbs. ammonia, equal to 28.8 lbs. chemically pure sulphate—and increase of 8.3 lbs.

At the inlet of the scrubber the amount of sulphuretted hydrogen per 100 cu. ft. was—

With unlimed coal	384 grs.
With limed coal	247 grs.

At outlet of scrubber—

With unlimed coal	285 grs.
With limed coal	151 grs.

Carbonic acid at outlet of scrubbers per 100 cu. ft. of gas—

With unlimed coal	1,280 grs.
With limed coal	1,017 grs.

Total sulphur in commercial gas per 100 cu. ft.—

With unlimed coal	15.7 grs.
With limed coal	6.8 grs.

Carbonic oxide in commercial gas—

With unlimed coal	6.4 per cent.
With limed coal	5.0 per cent.

Two samples of pitch from stopped pipes contained no lime.

Limed coke shows numerous white specks from $\frac{1}{16}$ to $\frac{1}{4}$ in. in diameter, with an occasional white blotch an inch or more in diameter.

A purifier in use during the liming experiment purified 50 per cent. more gas per barrel of mixture than at any other time.

Three days after commencing the use of lime the firemen complained of the increase of clinker. This was more easily broken, and the labor of each clinkering operation somewhat reduced; but the increase in quantity was great, necessitating a shaking up of the fire each time the furnace was filled. The firemen were heartily glad when the use of lime ceased.

I was unable to discover any change in heats, yield, illuminating power, or amount of fuel used that could be charged to the lime. The ammonia determinations were made by means of the distillation test.

Discussion.

Mr. Helme—Did you use stone or shell lime?

Mr. Clark—I used a very fine quality of stone lime that comes from either Alabama or Tennessee. I never tried shell lime.

On motion of Mr. Stiness a vote of thanks was passed to Mr. Clark.

The next paper in order was that of Mr. E. Stein, of Philadelphia, Pa. The author being temporarily absent, President Wood instructed Secretary Humphreys to read the paper. In accordance with that instruction the Secretary read as follows:

COMPARISONS ON COST OF GAS, ELECTRIC LIGHT, AND OIL.

The great advances made during the past few years in the matter of devising and constructing appliances aimed to secure a more economical utilization of gas have surprised even those who were directly interested in procuring the desired result, and the general public, having viewed with gratification the measures put forward, is also disposed to admit that these measures have been successfully prosecuted. The inventors or workers in the direction of the improvement of gas burning appliances have the satisfaction, then, of knowing, aside from any practical pecuniary gain which may accrue to them, that the fruit of their industry is as acceptable and valuable to any one of the struggling millions as it is to the millionaire. Indeed, I do not think I am wrong in making the statement that the difference in the lighting result obtained from the gas consumed under the present advanced plan, in contrast with that gained under former ordinary conditions, is as great as that which existed between the tallow candle of past generations and the first gas flame with which it was compared.

Not only does the public appreciate the change effected by the advance, but is anxious to secure the practical results thereof, as is shown by the demand from it for a more profuse and higher power light than that which formerly satisfied its craving. The researches of the inventor, as shown by his results, have stimulated the people to seek a higher standard. Public taste, and also its necessities, actually demands a brilliant light to satisfy its present wants, and it is equally set in its provision that this increased illumination must be secured without any important addition to the cost of that granted under the old *regime*. That somewhat arbitrary demand means a higher candle power from a given quantity of gas consumed; and it has been the aim of the inventor to secure the seeming paradox.

It would be useless to assert that to the gas men alone should be given the credit of this revolution in public sentiment. The electrician has had a hand in it, and the kerosene oil burner adapter has also been an important agent for its development. In fact the advances made in the development and improvement in forms of kerosene oil burners must not be underrated. These have undoubtedly played a positive part in the premises, and have been instrumental in maintaining kerosene oil in the front rank of the gas manufacturers' lighting competitors. Gas, kerosene oil, and electricity are the three systems competing for the favor of the public in the matter of artificial illumination. Our gas works are established, and the majority of these are well equipped for the proper manufacture and distribution of an illuminating agent not attended with the difficulties or surrounded by the dangers which constantly accompany its rivals. Where gas can be obtained we have only to adopt and employ the best means available for its conversion into light, to at once show its superiority, both as to quality and cost, over other illuminants, and thus substantiate the claim that, while it is the light of the present, it is also to be the light of the future. Again, every forward step taken in the direction of a better utilization of gas has a double effect. It not only gives the consumer a better and cheaper light, and brings him into more cordial relations with the gas maker, but also insures to the latter a greater demand for his product.

Practical and scientific men have of late years devoted much research and study to the question of how best to secure a gain, or rather to develop the latent light-giving power of gas; and, step by step, the advance secured points to the fact that gas heads the list, in that it is the greatest light giver for all requirements in which the aid of artificial illumination must be called upon, and that prominence is achieved at a figure which makes its cost less than that of any of its rivals, all things considered. By the employment of improved gas burning appliances the brilliant effects of the most widely heralded incandescent electric systems are surpassed, and, at the same time, the brilliancy is obtained at an expense but equal to that which will be urged as an argument in favor of kerosene oil by the advocate of the latter. This being so, it is, therefore, largely to the interest of gas companies that their

managers should bring to the notice of the public all the latest and most noted improvements in the matter of proper consumption of gas, and to facilitate or urge the introduction of those devices whose superiority has been demonstrated.

Remarkable progress in the development of the latent lighting power of gas has been made this year, and the achievement of the Lungren lamp, at the Novelties Exhibition of the Franklin Institute, Philadelphia, last October, may be regarded as giving substantial encouragement to the gas fraternity, for it proved that gas is capable of affording results sure to maintain it in the front rank as an illuminator. "Thirteen candle power per cubic foot of gas consumed" was the verdict given by the Committee on Lighting Tests appointed by the Franklin Institute. Their results were ascertained by measurements taken at an angle of 45°, and we find that the committee, referring to this fact, reported as follows:

"In measuring the light of the lamp (Lungren) the committee found it necessary to construct a photometer for the angular measurements. Horizontal measurements were made on the bar photometer used in testing the Siemens lamp. The flame of this lamp being entirely below the lamp, the horizontal rays do not represent its efficiency in actual use."

With such a result established, and the ability to maintain the same without increase in expense or the bestowal of frequent attention also placed beyond doubt, I am enabled to positively assert that illuminating gas can successfully compete with electricity or kerosene oil. In substantiation of the assertion, let me present the following comparisons:

I will first refer to the Lungren gas lamp in comparison with the incandescent electric light. The rate usually charged for commercial incandescent electric lighting by the promoters of that system is \$1 per month for each 16-candle power lamp supplied, the light to burn from the setting in of dusk to ten o'clock P.M. Placing the average time of daily lighting at five hours, we have, for 312 business days, a total of 1,560 hours per annum. A specimen of the Lungren lamp, consuming 12 cubic feet of gas per hour, will develop 150 candle power, and that rate of burning, carried on during the 1,560 hours of lighting for the year, gives a total consumption of 18,720 cubic feet of gas per annum. At \$1.60 per thousand (the rate in Philadelphia), the total cost of gas supplied and consumed is shown to be \$29.95. The candle power developed from the Lungren lamp taking up 12 cubic feet of gas per hour is equal to that afforded by nine incandescent lights of 16-candle power each. Now, nine incandescent lights at \$1 each per month will cost \$108 per annum—or a difference in favor of gas of \$78.05.

A second comparison, taking the Lungren lamp and kerosene oil consumed by the aid of improved oil burners as factors in the calculation, reveals the following: A duplex (or round wick) oil burner will develop from 20 to 23 candle power, and will absorb one quart of oil in eight hours. As seven of these will be required to yield the candle power afforded by one Lungren lamp consuming 12 cubic feet per hour, it will be seen that the seven oil lamps will consume 341 gallons of oil in the 1,560 hours, and the charge for oil alone, at 12 cents per gallon, will equal \$40.95, the expense of gas being, as before, but \$29.95. Here we certainly have proof as to a large percentage of saving gained by the use of the Lungren lamp, taking cognizance of the candle power of the resultant illuminating duty afforded over that secured from the employment of kerosene oil burners of the most approved types.

On motion of Mr. Harbison a vote of thanks was tendered the author.

AMENDMENT TO THE CONSTITUTION.

Mr. Stiness—Agreeably to the notice given this morning I now offer the following amendment to the Constitution: "To amend section IV. of the Constitution by striking out the words 'or engaged in industries relating thereto.'"

The President—The amendment will be referred to the Executive Committee.

Mr. Stiness—In this connection I desire also to offer the following resolution: "Resolved, That the Executive Committee be requested to present any other amendments which, in their opinion, may be of benefit to the Association." Adopted.

In the absence of the author (Mr. J. H. Armington, of Brooklyn, N. Y.) the Secretary was instructed to read the paper, entitled—

SOME SUGGESTIONS ON PAPER WRITING.

For many years it was the custom and practice of those interested in the business of the manufacture of illuminating gas to keep the items pertaining to that manufacture, and also in respect to receipts and expenditures, within their own control; and, too, as other well-conducted companies still continue to do, to regard their business relations as matters in which only their shareholders are interested.

That a wide difference of opinion on this subject is now entertained in this country by the managers of the gas companies may be readily seen by reading the proceedings of the various Associations of gas managers, as published in the journals connected with interests of this kind. Whether these published statements have resulted to the injury or benefit of the public—the

consumers of gas—or to the gas companies, is a question to be looked at from various standpoints. By the public, from the standpoint of their investments in worthless bonds, issued and sold to their dupes by dishonest persons, who are supposed to be engaged in building gas works in various localities throughout the country; by the consumers of gas, in allowing these smooth-tongued schemers to impose upon their credulity by promises that are not, and were never intended to be, fulfilled; and by the owners of gas companies, in localities that are or have been infested by these swindling operators, in the partial, and, in some cases, the total destruction of their property.

Is there any doubt that the most ruinous raids have been made on the old organized gas companies of this country, in consequence of published statements of the business affairs of these companies by (in a good many instances) those who were officers of those companies, and who either desired notoriety, or thought that their business showed better results, as a consequence of their financial management, than that of some other gas company?

If any doubt upon this subject be entertained by any member of this Association, the perusal of the daily newspapers, the published reports of various Associations—our own among the number—the published reports of various State legislative committees, and committees of Congress, will furnish plenty of proof—if proof is necessary—to confirm this statement. Had the writers, who wished to show their business transactions to the world, in connection with the manufacture and sale of gas, gone somewhat further in their publications, and shown that the price of coal, which so largely enters into the cost of gas, is an article liable to the same fluctuations in price experienced by other marketable commodities, and that it would be necessary to fix the price of this article at a specified sum, and naming as that sum a price which would render little or no profit to the companies mining the coal, and had they also ventured to fix the price of labor—that other large factor entering into the cost of gas, and which at the present time is such a very uncertain quantity, both as regards price and the amount of service to be tendered—then, indeed, the public and the consumers of gas would have seen that other interests must be consulted, and materially affected, as well as the interests of those engaged in the manufacture and sale of illuminating gas. It was said, after the appearance of a published report of a committee of the U. S. Senate (issued in July, 1886) to the writer, by a distinguished member of our Association, and after he had read the Senate report referred to, “I think it was a mistake to have published —’s paper on the cost of gas; and I am almost sorry that it was done.”

Our friend who had read the paper furnished that information for those directly interested in the proper and economical management of their business, and with the sole object of making his former statements, and also the position he had originally taken in regard to the proper mode of making illuminating gas, sure and strong with those who were vitally interested in knowing what was to be the result of a new departure in the manufacture, and the further effect of that departure on the present and future of investments directed to the object of the manufacture and sale of illuminating gas. That that paper did furnish this information to those directly interested we know, as we also do that it was at once seized upon and used before a legislative committee by certain interested parties, thereby causing much trouble and unnecessary labor for the officers of the gas company that had been made the subject of an uncalled-for investigation.

That the publication of the business affairs of gas companies has already brought about ruinous legislative enactments is evident from the laws recently enacted by the legislature of the State of New York, and the proposed legislative action on the part of the U. S. Senate for regulating the price of gas furnished by the Washington, D. C., Gas Light Company.* What other legislative bodies may follow the example of the State of New York, in attempting to arbitrarily fix a price at which a manufactured article shall be sold, remains to be seen; but that other legislative bodies will follow this example there can be no doubt.

The writer wishes to be thoroughly understood as not referring in any way to the spreading of knowledge, concerning the most improved and best methods of making illuminating gas, among those engaged in its production, but simply to those who seek to spread before the world every item of cost connected with its production and distribution, and who, in the opinion of the writer, thereby injures instead of advances the interests of established companies. The ignorant and fanatic appeals that have from time to time been made through the newspapers by those who were and are totally unacquainted with the manufacture of illuminating gas, have been, in many cases, based upon statements and figures made by those who should not have published them.

These figures—readily understood, of course, by those acquainted with our business, but totally misunderstood and misplaced by those ignorant of their meaning—have been the means of much misinformation to the general pub-

lic, and have begotten much animosity towards the companies engaged in furnishing an article so necessary to the comfort of the people. It is, therefore, hoped that hereafter such statements will be either withheld from general publication, or so modified and plainly stated as to be easily and perfectly understood by all who read the daily publications. The everyday management of the business of a gas company involves quite enough of care to keep busy all those engaged in its service; but these cares are added to by complaints on the part of consumers of gas who read those statements which have just enough fact about them to convey a false impression to the minds of those who are ever ready to imagine that they are being cheated. Then the cares and vexations of a manager are increased tenfold, and he fails to be favorably impressed at the lack of good judgment on the part of the one who gave forth the partial fact from which the false statement was manufactured.

That it is our duty to try and make clear to our customers that we conduct our business in a plain, straightforward manner, to patiently hear all complaints they may choose to make, to rectify any mistakes that may have been made, and, if possible, point out the way in which the person having a supposed grievance can in future avoid the same, there can be no doubt. That we should take particular pains to listen to complaints and then explain the seeming trouble is shown in the fact that the large majority of those with whom we deal are inclined to assert gas companies are monopolies, and the charge is brought against them, as against many other companies doing business with the public, that the officers will not listen to complaints, and that redress for alleged abuses cannot be obtained.

Did we believe what is said of us by many newspapers, and also by those who delight to join in the popular cry that all persons, except the criers, are dishonest, we should soon conclude that our business is the only one that honest men have never been connected with, and that those of us who have engaged in this business have been unfortunate enough to have associated ourselves with those who have lived and prospered by defrauding the communities in which they resided.

That none of our own profession may hereafter furnish “aid and comfort” to those who seek to place us in a false light before the public, by publishing partial statements of their business, is the wish and hope of many others than the writer; and if, by having called the attention of the members of the Association to this subject, further injury to our business may be prevented much will have been accomplished towards correcting a great evil, and may prevent further attacks, from thoughtless and unprincipled persons, upon our reputations, and upon our business and property as well.

On motion of Mr. Stiness, a vote of thanks was passed to Mr. Armington for his paper.

Discussion.

Mr. Harbison—I am hardly willing that this paper should be allowed to go on our records as voicing the sentiments of the members of this Association. I hardly believe that the majority of the members agree with the spirit of that paper. I do not believe the interests or the business of gas companies suffer through letting the public know what we are doing. I am not afraid, as representing one company, to have the people whom I serve know what it is doing. I am not afraid to let them know what our gas costs us, or what money we are making. We are trying to do an honest and legitimate business, and the better the people know, and the more thoroughly they understand that the better it is for us. I am not aware that any information has been given to the public, through this Association, in regard to the cost of making gas, which resulted to the injury of any existing company that had been doing a fair and legitimate business. If some gas companies, by having charged exorbitant rates, invited restrictive legislation I think they are alone to blame for it. I fear that such is the case. I do not apprehend we need fear legislation restricting the price of gas in the different cities of the country where but a fair and legitimate price for gas is charged—a price that enables the companies to pay a legitimate dividend on capital actually invested. Speaking for myself, I am not willing that the sentiments of that paper should go forth as the sentiments of this Association without making a protest against it.

Mr. Littlehales—I thoroughly concur in the remarks made by Mr. Harbison, and was about to rise for the purpose of offering the same protest. We meet together to relate to each other the facts in our varying experiences, and we can only improve our practice by letting each other know the results of our experiments; and as the paper just read has no such object I hope the Association will not accept it. I offer a protest against the spirit of it.

Mr. Helme—Might it not be well, as that paper is in the nature of a lecture, neither to spread it on our minutes nor to publish it. For my part I question the policy of ever having papers read unless the writers be present. Several years ago this subject was thoroughly discussed by the Association, and in one case that I recollect a paper was allowed to go over unread for two years, although it finally was read in the absence of its author. In fact, he has not attended any of our meetings since.

Mr. Littlehales—I think that this paper ought to have been dealt with in

* See JOURNAL, Aug. 16, 1886, p. 108.

a similar way. I move that it be laid over to be taken up when the author is present to take part in the discussion.

The President—This paper has been read, and so the case differs from that spoken of by Mr. Helme.

Mr. Littlehales—Then let it not be published.

Mr. McMillin—I forget whether the motion for a vote of thanks was put or not.

The President—It was put and carried.

Mr. McMillin—Is the suggestion now made that it shall not be published?

The President—That is the suggestion of Mr. Littlehales.

Mr. McMillin—I think that would be a mistake. We have voted to thank the gentleman for his paper, and I think it better to have it published with the regular proceedings, although we may condemn the sentiments. There are two sides to all questions, and one view has been presented by Col. Armington, while there are members here ready to present the other side. In fact I think that the members are somewhat unanimous on the "other side" of that question. I do not believe the gas business was ever injured by facts brought out during the meetings of this Association. I think, as gas men, we have been helped in that way; and certainly the community has been helped. I am in favor of letting the world know what we are doing. I think we had better publish that paper along with the rest of our proceedings so that it may be seen how great a mistake a very good man may make. (Applause.)

Mr. Harbison—My motion to not publish the paper is withdrawn, because the publication of it will be followed by a report of what has been said by the members in connection with it. With that in mind, I think the paper ought to be published, and then the public will have an opportunity to judge whether it voices the opinion of one man or of the Association.

Capt. White—I think it would be a very grave mistake for this Association, gathered here as we are for the purpose of exchanging ideas, to receive a paper from Mr. Armington in which he expresses his views upon a topic of very vital interest to us all, and then seek to stultify ourselves by taking the position before the public that we dare not have one of our members express his convictions; and, further, that a paper prepared by him, upon invitation of the Secretary of this Association, and read here before us, should be suppressed. It is the most ridiculous thing I ever heard of. Has this Association got to be so old-fogyish that its members dare not express their opinions for fear of being sat down upon? If it has come to that I think it time that this Association should disband. I think it is due to Col. Armington that his views should be spread in full upon our record. I trust that the paper will be printed in full. Col. Armington is prepared to bear his part of the onus—if there be any to bear; and, as Mr. McMillin very ably said, we wish the public to understand what we are doing in these meetings, and to know that we are trying to make a better and a cheaper gas from year to year. That is what we are here for. We leave our homes and business and come here so that we may be able, by learning and profiting from the experiences of each other, to make better and cheaper gas. I question very much our right to refuse to publish this paper, and insist upon its being duly received and made a matter of record.

Mr. Littlehales—At the time I made the motion to not publish the paper I was under the impression, from the statement of the President, that no discussion was to be had on the paper because the writer was not here to defend it. If this discussion goes along with the paper I am satisfied that it should all be published, and in that understanding withdraw my motion; but I decline, as one member of the Association, to let those views go forth as the views of the Association without a protest.

The President—Mr. Littlehales misunderstood the Chair. It was intended by me to say that Col. Armington, not being present, could not answer questions, but that the paper was open for discussion.

Mr. Littlehales—Then I misunderstood you.

The motion being withdrawn, the regular order was proceeded with.

The President called for the reading of the last paper on the list. It had been contributed by Mr. Charles F. Spaulding, of Brookline, Mass., and as that gentleman was absent from the room when the reading was asked for, the President designated Mr. A. B. Slater to place Mr. Spaulding's remarks on

ELECTRIC LIGHTING

before the members. Mr. Slater read as follows:

Fellow-Members of the American Gas Light Association:—Again we meet in conference to discuss ways and means, to compare notes with each other, and to renew the pleasant friendships formed from year to year in the past. To say that I am pleased to be with you would be superfluous, for I feel that we are friends having kindred interests to consider; and although circumstances have placed me somewhat outside the fold, in that I have been thrown among our whilom rivals in charge of the destinies of electric lighting, still I return to you with enlarged ideas concerning the future possibilities of the gas companies of the country, and with a more liberal (and I believe a truer) idea of the possibilities of illumination by electricity.

We were, as you know, inclined to look upon the electric light as a temporary affair, or a "clothes-line" sort of arrangement which would soon die a natural death, and thus leave us a clear field. That we were mistaken needs no argument of mine to prove. The electric light came, was welcomed, and will remain with us. We ought to look upon its permanency as an acknowledged fact, and endeavor to frame methods by which we shall be able to prevent a ruinous competition. How shall this be done? By fighting the inevitable, or by making the electric light a co-servant of gas? Surely you will say the latter; and the result of my own experience in the electric lighting field during the past two years would endorse the wisdom of that decision.

Now, gentlemen, it is presumed that we meet here as partners in a common cause; we are interested in the gas business because of the profits to be derived therefrom, and not as philanthropists. If we are doing a satisfactory business, why not take such measures as will insure its continuing so? And if we are doing a losing business, why not embrace any chance that may offer to improve it? My advice to those in charge of any gas lighting company, whether prosperous or otherwise, would be to prepare to do both kinds of lighting—electric and gas—and thus best serve the public; for it is from the public we must look for support.

The common arguments against the business of electric lighting are its unprofitableness, and the instability of the methods of production. Both of these are groundless (the first-named notably so), as can be proven by the results attained in any well regulated electric lighting station that employs a good, practical system, and by any company not hampered by a fabulous capitalization.

The whole question of profit is a simple one—it emanates from the fuel, and culminates in the light produced and money earned therefrom. Still I have this to say—that much depends on the choice of a "system," for there are both worthy and unworthy on the market; but between them are some which might be considered as possessing a few of the characteristics of each.

Age and antecedents add nothing to the value of an electric lighting system, for the machines which satisfied the crude ideas and requirements of years ago have been superseded by newer and more improved apparatus. The period has not long since passed since the flickering and noisily-feeding electric lamps were considered good enough—when such a matter as the automatic regulation of a dynamo was a thing unheard of; but now, the public having become aware that a steady and noiseless electric light is a possibility, and companies knowing that a self-regulating dynamo can be obtained, these factors have relegated to disuse the older and more incomplete systems of the past. I speak thus particularly of automatic regulation for dynamos and the noiseless feeding of lamps because I consider them of paramount importance to any company desiring to operate an electric lighting plant and business with profit to itself and satisfaction to its customers. Added to these are the items of cost of maintenance and renewals, which, in some systems, are excessive and render them unprofitable to the operators thereof. Burned out armatures and lamps, the re-turning of commutator segments, renewals of brushes, etc., are items of considerable importance; and if it has been our misfortune to invest in a system with which it is impossible to do away with these, the profit side of our books will look somewhat slim.

So, my friends, whenever you feel it to be to the interest of your company to consider the matter of an investment in electric lighting apparatus, you cannot do better than to buy only after the closest personal examination and inquiry. Let not friendship or prejudice bias your judgment, and consider only the object of securing such a system as may be purchased at reasonable figures, and which may be afterward maintained at small cost.

My own experience in electric lighting has been on the practical side. I have been interested in ascertaining, from actual results obtained personally, just what the possibilities might be in this field. I have listened attentively to the many claims made by electricians and representatives of electrical interests, and then have acted just as I should advise all my friends to act—investigated personally and practically the basis of their claims. To say that I have been disappointed and surprised at the strange discrepancy between some of the claims and actual results obtained goes without saying; but, however, the satisfactory has far exceeded the unsatisfactory.

Now, gentlemen, allow me to suggest that an informal talk on this subject at the present time would be opportune, and I shall be pleased to answer such questions as may be put forward relative to the matter.

On motion of Mr. Harbison the thanks of the Association were tendered to Mr. Spaulding.

Discussion.

Mr. Findlay—I would like to ask those familiar with the matter if the supply of electric light can be made a profitable operation in a village of 4,000 inhabitants. We have gas works in a small village, and last year we sold two million cubic feet. The Thomson-Houston Company have located a plant in our district, and they propose to supply arc and incandescent lights. I have heard many different opinions with regard to the probable outcome,

and I must say I feel rather "shaky." If anyone can help me out I would like to hear from him.

Mr. Littlehales—I would also like to know whether it is possible, as some suppliers of electric light claim, to supply conveniently, from one and the same wire, both arc and incandescent lights. I have understood that that operation involved the maintenance of rather an expensive apparatus to convert the one system into the other. Is the plan practicable?

Mr. Diall—I can answer that question as far as we at Terre Haute (Ind.) were concerned. The Thomson-Houston folks attempted to supply both arc and incandescent lights from one wire, but made a failure of it.

THE QUESTION BOX.

The President—We will now take up the question box. The first question is—

"How can the demand for tar be increased, and larger profits be realized therefrom?"

I suppose Mr. Page has studied this thing so that he can answer the question concisely, and in a few minutes tell us all about it.

Mr. Page—A proper reply to that question cannot be made at this late hour; but those who follow the course of the residual market in this country and in Europe know that there never has been a time of greater depression in the matter of the sale of residuals; and that depression has largely grown from natural causes. First, I may state that the greatest consumption for coal tar abroad is for making artificial fuel, while with us it has been most largely used in making roads. Abroad, the low price of fuel has interfered with the consumption of pitch, and great quantities of it have accumulated. But little income has been derived from that source. On this side of the Atlantic the roads, instead of being made of asphalt from coal tar, as formerly, are being made from the imported natural article, a result largely brought about by the wealthy corporation that has the exclusive concession for mining asphalt at Trinidad. This company has branches in various cities, and the natural asphalt, being cheap, has taken the place of the coal tar article. Again, the use of creosote oil having in the past been carried on to so large an extent that the timbers in the great docks and the ties in the railroad beds have about all been treated—there is but little wear and tear on or decay in them—the natural outlet for creosote oil has been diminished, and its price has gone down from 3d. or 4d. to 1d. per gallon. In fact the consumption of creosote has decreased to such an extent that it has been impossible to sell it, and much of it has been burned under the retorts and boilers of the different gas works. The price of pitch has diminished from 35s. or 40s. per ton to 6s. and 8s. per ton. The great increase in the use of the benzoles for color making, and the great profits derived therefrom by the earlier manufacturers, caused tremendous competition; and now enough benzole is made in Germany in one year to supply the demand of England, France, and America for two years. In consequence anthracene has gone down from 6s. per unit to less than 1s. per unit. So each of these products could be mentioned in order; and therefore at the meetings of the directors of foreign gas companies, and at the Association meetings, we hear the question constantly asked, "What shall we do with our tar?" The final determination was, to make a value for the portion really required, to burn the excess; and that has been done. Tar is worth so much per gallon as fuel in place of coke; and in order, therefore, to secure a good price for the balance, a part of it must be consumed under your retorts. That is the most economical way.

Mr. Littlehales—During the last two years we had much experience in the using up of our tar. Tar is not easy to store; but I do not think it is desirable to burn it, provided a better plan be at hand. Five or six years ago the Company (Hamilton, Ont.) with which I am connected laid down one or two hundred square yards of asphalt pavement made out of tar and ashes. Having stood for some years it showed such excellent results that the City Engineer and Board of Public Works decided to try it on a larger scale. They were anxious to get as good work as we had secured in our experimental section, and so they asked us whether we would undertake it for them. Last year we laid about 7,000 square yards, and during the past summer we put down 9,000 square yards, at a cost of 55 cents per yard. That enabled us to get at the rate of \$2.75 per barrel for our tar, and a fair margin of profit on the work besides. I am perfectly satisfied our Company can make a grand market for its tar in that way. I believe it is advantageous to take charge of the pathmaking ourselves, because if left in the hands of contractors, whose only interest it is to make all they can out of the job, poor work will be done, and the system will be condemned. That was the reason why we took charge of it. We wanted to have sufficient work done of such a quality as would insure a standard. We would have laid last summer a greater number of yards of pathway if we could only have secured a greater supply of the sort of ashes necessary to make a good job.

Mr. Greenough—Has the business been so prosperous that you would like to buy 30 or 40 thousand barrels of tar?

Mr. Littlehales—If we could get two or three hundred carloads of ashes we could safely buy a few thousand barrels of tar.

Mr. Nettleton—I was about to suggest the same thing spoken of by Mr. Littlehales. In our part of Connecticut (Birmingham) the soil is sandy, and in consequence tar pavements have been laid to a very large extent. The gas companies in our neighborhood have no difficulty in getting rid of tar at good prices. The tar pavement comes cheaper than stone; it remains even and smooth for years, when well laid on sandy soil, and is very comfortable. Where a loamy soil is met the loam is dug out to the depth of 12 or 18 inches, then sand is shoveled in and the pavement laid thereon. It is not necessary, however, as Mr. Littlehales seems to think, to use all ashes. The bottom course with us is made of cobbles, two to three inches in diameter; the top coating is composed of sand and ashes, in the proportion of two-thirds sand to one-third ashes, mixed thoroughly with tar, and spread on with a roller. It makes a very serviceable pavement. In our neighborhood no tar is sold at less than \$2 per barrel, and sometimes it brings considerably more.

Mr. McMillin—Mr. Greenough privately suggested an answer to that question a few minutes ago, but he was too modest to give it to the Association. I think it is a very good one. He suggested that the Philadelphia Gas Trust convert the Quaker City works into a water gas plant, and then gas tar would at once be worth \$2 per barrel all over the country. Our remedy for low tar prices at Columbus, Ohio, was to get a complete set of drawings for a plant for the manufacture of tarred paper, benzole, or every other product that could be made from coal tar. We next let that fact be known generally to the coal tar manufacturers and chemical works, and the price for tar at our works went up right away from 2½ to 4 cents per gallon.

Mr. Lowe—I would like to ask Mr. McMillin if he did anything with that complete set of drawings?

Mr. McMillin—I loaned them to our friend Page. In fact I think I borrowed them from him in the first place.

Mr. Lowe—Such being the effect, I think every member of this Association had better procure a similar set of drawings at once.

MR. TURNER ON EARTHQUAKES.

The President—Someone wishes to know if Mr. Thomas Turner, of Charleston, S. C., will kindly relate some of his recent earthquake experiences. Another querist asks, "Will Mr. Turner, of Charleston, S. C., inform us whether the late earthquake in that city caused any breakages in gas mains or services, and what its effect was upon the gas supply?"

Mr. Turner—Mr. President and gentlemen, I do not know why I should be called upon specially to tell you (for I am pretty much like everybody else, I know little or nothing about them) about earthquakes. To be sure, we had a very severe earthquake in Charleston, and I can speak as to the effects of this one which damaged our works materially—so much so that, notwithstanding all our efforts during six weeks to find out and stop the leaks, our leakage was nearly 60 per cent. for the month of September, and at the commencement of that month must have been about 75 per cent. The mains, particularly at the crossings and intersections of streets, were very seriously disturbed. In a space the width of the street, and from 25 to 50 feet beyond, as many as seven or eight breaks would be found. The services of all calibers, from three-quarters of an inch up, were literally torn out of the mains, very often they carried a portion of the main with them. Our works are pretty badly wrecked. Nearly every building will have to come down. So far as we can ascertain, at present at least, our tanks were not injured. The main tank and holder is at our works, and smaller holders are distributed in different parts of the city. The holder tank at the works, which is 26 feet deep, 98 feet diameter, and built of brick, oscillated to such an extent that the earth or backing at the level of curb was pushed back 8 inches to the southeast, showing the wave was in that direction. The tank recovered its original position, leaving the earth as before. As far as I have been able to ascertain from scientists the effect of this earthquake was pretty much like that of dropping a pebble in a pool of water; from the center the waves diverge in different directions. We were to the south of this center. At Summerville, where I was residing at the time, the waves seemed to go in a northwesterly direction, and at other points they seemed to go in a northeasterly and southwesterly direction. Our manufacturing plant in Charleston was not materially injured. After some little delay we were able to continue furnishing gas. Around our works the joints of pipes and connections were dislocated in many instances. For example, the cover of a dry centervalve was jammed out of its place until every box was passing foul gas.

Mr. Lowe—To what extent were your street mains injured?

Mr. Turner—I am not able to tell that. I suppose I have repaired, up to this time, about 100 breaks. I know there are quite a number more, and I find, on the lines of upheaval or waves, the joints drawn and leaking badly. This I am afraid will be our principal difficulty. I suppose that our leakage at this time is fully 40 per cent., but I hope in a few more weeks we will be

able to get it within reasonable control; yet the task seems almost endless, and later shocks have again disturbed them.

Mr. Helme—Your benches were built on piling?

Mr. Turner—They were originally built on piles, but having changed that mode of construction some years ago, they are now built on a concrete bed, which is virtually floated, as it were, on bluff mud—a local term—and I believe to that fact the salvation of our benches is due. They were not disturbed, except that one or two tie-rods were broken, and the upright flues to one stack thrown down. That foundation of concrete is about three feet thick. The benches are built on inverted arches, of the same size as the arch of the oven. I was in hopes to have had here some photographs of our coal stores, showing their condition, but they have not yet arrived. I think the disaster to our coal house was principally due to the large amount of coal on hand, the coal, being piled against the walls, when the shock came overthrew them.

Mr. Helme—In case you rebuild do you not think that a strongly timbered coal house would be better?

Mr. Turner—That would affect our insurance.

Mr. Helme—But, putting the question of insurance aside, do you not think that if the house had been strongly timbered it would have stood the "racket" better?

Mr. Turner—I do not think so. I think the large amount of coal we had in store would have burst out the woodwork just as it did the brickwork. We store our coal about 15 feet deep, and the piers of our coal shed are 15 feet 6 inches apart. These piers are 2 feet 6 inches square, and a curtain wall 18 inches thick, on the closed side, battered from the outer edge of the pier at the bottom to the inner edge of the pier at the top, runs from pier to pier. The walls and piers are torn out a foot below the joists.

Mr. Helme—Did you find the iron frame of the retort house roof injured?

Mr. Turner—Only the purlins running into gable end, which came down on coal shed. I believe the safety of the retort house is due to the new iron roof, which I put on two years ago, and to the mode of construction. I believe it is the universal practice to simply lay the roof on the walls, but in this case I had bolts made to go three or four feet down into the walls, with a plate built in brickwork, and I think that the safety of our retort house is due to that fact. It is in pretty good condition excepting at the gables and corners to first rafter which will have to come down. The inlet and outlet pipes of the tank do not seem to be injured; and I think that fact is due to the peculiar nature of the ground in which our tank was built. The first section of brickwork was put in on the surface of the ground, the mud was then excavated, then another course put in, and so on down to the bottom. This mode of construction was due, I believe, to Mr. J. P. Kennedy.

Mr. Helme—How did you fare on your wharves?

Mr. Turner—The wharf is pretty good, but our railroad track, which is 800 feet long, was thrown bodily 13 inches to the east—that is, endwise. The wharf is built on piles. There is a shed near to us belonging to the South Carolina Railroad Company, which contained at the time 1,500 tons of guano. That shed was moved bodily eight feet and some inches. It was also built on piling. I can tell you, gentlemen, there is no uncertain thing about an earthquake, and I do not know what sort of structures you will have to provide if you are likely to be visited by one. A writer on one of our daily papers remarked that the causes of earthquakes are pretty much the same as they were 100 years ago. He compared it to the drying of an apple—the escape of the gases from the interior wrinkles the skin—and he suggests that Charleston has had its "wrinkle." Of course, everybody has a different theory as to cause of earthquakes, and it is hard to say who is right. One of our clergymen, a noted geologist, who thoroughly understands the nature of our soil, says that Charleston is situated on an alluvial deposit, whereas Summerville, where I was residing at the time of the disturbance, is built on a marl and phosphate deposit, with an underlying strata of limestone caverns, and he attributed the earthquake shock to the caving in of these limestone caverns. Whether he is right or not of course we do not know. Others seem to think that there has been a subterranean upheaval, which fissured the ground and forced the underlying water and sand to the surface. This latter seems to me very probable.

Mr. Helme—Did it affect your artesian wells?

Mr. Turner—Not at all. One, which is about 2,000 feet deep, was apparently not affected in the slightest degree. It affords fresh water of a mineral nature or tincture.

Mr. Helme—How was the section from whence the phosphates are taken affected?

Mr. Turner—The whole face of the country shows fissures and geysers. A hole appears in the ground, and water is thrown from it two or three feet, bringing up with it 12 to 14 different kinds of sand. I have at the hotel some specimens of this sand which were thrown out by the geysers.

Mr. Helme—Do they come from as low down as the phosphates?

Mr. Turner—They are from below the phosphates, I believe. The phosphates are generally near the surface.

Mr. Helme—I saw a newspaper statement to the effect that no case had been found of any disturbance below the phosphates. Does that seem to be correct?

Mr. Turner—I was informed that one fissure had been sounded with a twenty-foot rod, and no bottom found. I said I was living at the time at a place 22 miles from Charleston—Summerville by name—which seemed to be the center of the disturbance. I firmly believe if they had had in Charleston as severe a shock as we had in Summerville there would not have been a brick house left on its foundation. At the time of the shock I was thrown ten feet into the house, and almost instantaneously thrown out again. A member of my family was thrown from one room into the middle of the next one, and a neighbor, in the act of closing the shutters, was thrown through the window into the lot.

Mr. Helme—How did you fare at your office?

Mr. Turner—Our office was but slightly damaged. It is a most singular feature of the result of the earthquake that you may go along the streets in Charleston and out of three stores or houses close together two of them will be found completely wrecked, while the third was hardly injured at all.

Mr. Helme—Was the wall on the battery disturbed?

Mr. Turner—The walls were not disturbed, but the houses in that district were very badly injured. The greatest damage was at the lower end of the town, or where the greatest number of brick and stone buildings were to be found. The frame houses do not seem to have suffered much externally. Some assert that the shock came from the southeast, from the sea, and others say it came from the southwest; but I rather think everybody was so thoroughly demoralized that they did not know from which way it came.

The President—It was claimed, in some of the northern papers, that the material used in constructing the houses in Charleston was bad, and that that weakened them. How is that?

Mr. Turner—That may be so in some cases, but in very few. You who have visited Charleston know that on their building work they favored a great deal of ornamentation. Heavy cornices of brickwork are the style, which would tend very naturally to overload the walls and lead to injury from such a shock as this; but instances are quite numerous where the best kind of work, which would be difficult to take to pieces, is so badly shaken as to require to be taken down. Here in the North you use a great deal of galvanized iron for cornices; and I do not think our buildings would have suffered so much if they had had that sort of cornice. Still, it is hard to say, under a shock like that we experienced, what would have been the result, and I doubt if the brickwork in any city could have withstood it intact.

Mr. Helme—Charleston was a well built city at the time of its erection; and they can say what they like about the workmanship displayed, but I believe no other city of this country had more care taken in its construction than was the case in the original Charleston plan.

Mr. Turner—All of the older buildings were built of the best gray brick—as good a brick as can be found anywhere in America—carefully laid up in good shell lime. Only of late years has stone lime been used. No better mortar could have been used than that employed in the construction of our coal sheds. The walls as a mass were not disintegrated, but pieces of them were thrown out in solid chunks. I have seen instances where the bricks, though broken in small pieces, still held together by the mortar—showing the best material and construction possible.

Mr. Young—Have you had any gas explosions as a result of the earthquake?

Mr. Turner—None at all. I at once advertised in the daily newspapers cautioning people to have their gas fixtures examined. I found, in a number of instances where buildings had been shaken, that all their fittings were more or less distorted and dislocated, and some rather curious instances of increased bills resulted from that fact. There were no leaks perceptible in the buildings, but of course the gas would ascend and make its escape through chinks in the roofs.

Mr. Lowe—I should have thought, from the number of breaks, that in some cases the gas would have passed from the street mains into the houses, and so caused explosions.

Mr. Turner—One thing possibly acted as a safeguard against that. For the first three weeks or a month the majority of the people lived out of doors, and very little light was used in the houses.

Mr. Lowe—What is the character of the soil in which your pipes are laid?

Mr. Turner—It is a very porous soil—chiefly sand, with a substratum of yellow clay. Our pipes (or many of them) are laid in the made land rather than in the "virgin soil," as they term it.

Mr. Lowe—At what depths are they laid?

Mr. Turner—At depths varying from 10 inches to 2 feet.

Mr. Lowe—I move that the sympathy and well wishes of the Association be tendered to Mr. Turner and the Charleston Gas Company in this their hour of misfortune, and also that we thank him for his explanations.

The motion was unanimously carried.

UNIFORMITY IN METER CONNECTIONS.

Mr. Hyde—It is well known to all gas men that we have considerable trouble in making meter connections, because the manufacturers do not make uniform sizes. It seems to me to be desirable that there should be some action by this Convention calling on the different meter makers to agree upon and adopt a uniform standard size. I move that the President appoint a committee of three, who shall endeavor to establish a uniform size of connection for all meters, so that gas companies will not continue to be annoyed, as they now are, from the existing diversity.

Seconded by Mr. Harbison, and adopted. Messrs. F. C. Sherman, of New Haven, Conn., H. B. Leach, of Taunton, Mass., and C. F. Prichard, of Lynn, Mass., were named to compose the committee.

THE PROPOSED FORMATION OF AN ASSOCIATION FOR PENNSYLVANIA.

The Secretary stated he had been asked to announce to the members the formation of a new Association to be called the "Pennsylvania Gas Association."

VOTES OF THANKS.

Mr. Littlehales—I feel it to be due to our worthy President, before we disperse, to express our appreciation of the way in which he has presided over the meetings of this Association. I therefore move a vote of thanks to President Wood for the manner in which our business has been conducted by him. (Seconded by Mr. Harbison.)

The resolution was unanimously adopted, by rising vote.

The President—I thank you, gentlemen, for this kindly expression of your good will. I have, in this as in all other things, and on all occasions, endeavored only to do my duty. If I have accomplished that I can retire with satisfaction to myself. I believe that the Association will remain under my care until to-morrow evening, when we shall finally disperse; and I will try to lead you, under the direction of the Committee of Arrangements, through the byways and highways of our journey to-morrow.

Mr. Harbison—I desire, in behalf of the Association, to move a vote of thanks to our able Secretary for the very satisfactory manner in which he has conducted the duties of his office during the past year.

The President—The thanks of the Association are eminently due to our Secretary.

The resolution was unanimously adopted, by rising vote.

The Secretary—I am gratified, Mr. President and gentlemen, by your kind expression of approval.

The business sessions were thereupon declared adjourned.

A Supplement to the Chapter on Practical Gas Making.

By FREDERIC EGNER.

A number of inquiries have been received by the writer with regard to this or that point mentioned in the article which appeared in a recent issue of the JOURNAL.* It was therefore deemed desirable to explain more fully the subjects referred to in that "Chapter." The method employed to enrich coal gas by means of oil, the results of which were given in the issue of the JOURNAL mentioned, was designed by the late Mr. I. Herzog, formerly Engineer of the Metropolitan Gas Light Company of New York city—the writer acted as Mr. Herzog's assistant at a period of a dozen years ago, at which plant this manner of enriching coal gas was then in use. A small tank was placed on brackets fastened to the exterior of the retort house wall at a point high enough to give a head of from 4 to 6 feet to the stream running to the retort which it was intended should be used for oil. A $\frac{3}{4}$ -inch pipe was run from the bottom of the tank to the inside of the retort wall, and then furnished with a good valve. A nipple and tee-piece were screwed into the valve. One side of the tee received, through the aid of suitable nipples and ells, a long glass tube intended to show the height of the oil in the external storage tank. The other side of the tee was connected to a glass gauge, in all respects similar to the glass water gauges used on steam boilers. Though this gauge the oil had to pass, and so the size of the stream could be always seen or noted; and that, of course, is of great assistance to the operator. Being entirely closed, there was no possibility of the oil taking fire. From the bottom of the gauge the oil was led, through a $\frac{1}{2}$ -inch pipe, to the mouthpiece of the retort in which it was intended to be decomposed. A hole, sufficient in aperture to admit a $\frac{3}{8}$ -inch pipe, was drilled through the side of the mouthpiece, and the crevices around the pipe were made good by the application of a few handfuls of clay luting. Just outside the mouthpiece the feed pipe was fitted with a $\frac{1}{2}$ -inch service cock, a nipple, union, reducer (from $\frac{1}{2}$ -inch to $\frac{3}{8}$ -inch), and a short piece of $\frac{3}{8}$ -inch pipe, furnished with an ell and another nipple, about 4 inches long, completed the belongings of the oil feed pipe into the retort. The $\frac{3}{8}$ -inch pipe was passed through the mouthpiece from the inside, then the reducer and union were screwed on, and thus the connection was made. Leather or asbestos wash-

ers only should be used about the oil pipe, because rubber soon dissolves when in contact with naphtha or crude petroleum. The 4-inch nipple referred to just enters the open end of a piece of 3 or 4-inch cast iron pipe laid into the retort, and serves to conduct the oil into said larger pipe. The latter is laid so as to have a slight fall toward the back end of the retort, and should reach to within 8 or 10 inches of the back end. The point at which the $\frac{3}{8}$ -inch pipe enters is also securely closed up with clay luting. Bricks are laid around the large pipe in the retort in such a manner as to completely cover it (the pipe), or suitable tiles might be provided. All the foregoing being attended to, put on the retort lid, and you are ready to start in the making of oil gas.

It has been found, in practice, that one retort in a bench (the remaining retorts of which were charged with coal), kept at a good working heat, would carbonize at the rate of 10 gallons of gas naphtha, or 8 gallons of crude petroleum, per hour, for weeks at a time, and without any stoppage. If the oil retort is provided with any arrangement for bye-passing the seal in the hydraulic main, it will work all the better for it. It will be found that the "color" of the oil retort when in operation, and naphtha being used, will be of a dull red; with crude oil, a bright red—this, too, when the coal retorts may show a white heat. Should the oil retort color show brighter or darker, less or more oil should be fed in. As the writer has followed this system for years, he is able to speak positively in regard to it. Let it not be understood, however, that the method described is put forward as the best plan for making a pure and simple oil gas. Such claim would be grievously in error. But it is advanced as the safest, simplest, and probably the best way to use oil as an enricher of coal gas. The coal gas will carry nearly all of the oil vapors—that is, those which were not thoroughly gasified or decomposed in the retort—for a long time; and such oil as may be found in the drips will be seen to be of much heavier grade than that originally fed into the oil retort. Its color also differs; in fact, the drip deposit is little else than naphthaline dissolved in naphtha. Where the above-described process or method of enriching is carried on no stoppages from naphthaline will occur.

The preceding directions, it would seem, ought to make plain to anyone the manner of enriching coal gas with oil referred to by me in the previous "Chapter." It might be added that, to work with advantage, an exhaustor is necessary.

It is next in order to describe the process by which a product of over 6 cubic feet of 22-candle gas was obtained from a coal that ordinarily produced only 4.25 cubic feet of 14-candle gas. The coal alluded to was the Indiana caking variety, mined in Washington, Daviess County, Ind. The process of working being the invention of the writer, for that reason, and also because it had not yet been sufficiently tried to satisfy him, as a gas engineer, of its permanent benefits, so little was said about it. For good and sufficient reasons, which, however, are of no general interest, scarcely a week's steady work has been had with the new apparatus as a coal bench. The initial trials nevertheless were such as to encourage further attempts, the results of which will be made known to the readers of the JOURNAL in due time. Briefly, at present it may be described as consisting of an ordinary coal gas bench. The gas and vapors generated in the retorts do not pass directly to the hydraulic main, but travel from the mouthpieces of the primary retorts into the mouthpieces of narrower vessels, or fixing chambers. Having passed through these they are directed into the hydraulic main, as usual. That the vapor from the coal near the mouthpieces is not all converted into gas must be plain to every gas maker. This has been demonstrated by many—notably by Mr. Darius Davison, whose system is (or deserves to be, at any rate) well known. It is conceded that the tar vapors might, for the greater part, be converted into a very rich gas; but it is equally well known that, once the tarry vapors become *tar*, it does not pay, for many reasons, to attempt to gasify them. While in a vaporous state they might be acted upon, to some extent at least. European, notably English, engineers have acted on that theory to a great extent. The great danger in gasifying tar vapor is that the process might be carried too far, and hard deposits difficult of removal be lodged in mains and connections. The writer, however, believes that two or three thousand cubic feet more of a rich gas than is now obtained can be extracted from each ton of coal carbonized; and that would well recoup us for any losses chargeable to a decrease in receipts for sales of tar—at all events at the prices now prevailing for that residual. The other residuals—coke and ammonia—would not be interfered with at all, for these would remain as before, or as they are.

A Lecture on Natural Gas.

A lecture on the subject of natural gas was delivered at the Franklin Institute, on Saturday evening, December 18th, by Mr. Charles A. Ashburner, Geologist in Charge of the Pennsylvania Geological Survey. The lecturer stated that natural gas was by no means a recent discovery. Even its utilization for the purposes of the mechanic arts had been successfully attempted in

* See Vol. XLV., Dec. 16, 1886, p. 363.

China, where, by pipes of bamboo, it had been conveyed from natural wells to suitable furnaces, where, by means of terra cotta burners, it was consumed. In the confines of Persia, in the south of France, and in our own Western States, burning springs had long been known. When Lafayette visited this country in 1821 the inn in the town of Fredonia, N. Y., was illuminated in his honor by gas procured from a neighboring well. It is, however, only within recent years that natural gas has arisen to any importance in its bearing on the mechanic arts. At present the great iron and glass works of Pittsburgh and of other places are supplied with natural gas as their only fuel, and millions of cubic feet are yearly consumed in Pittsburgh and similarly situated cities.

Of the origin of natural gas there seems to be no reasonable doubt. It arises from the decomposition of forms of animal or vegetable life embedded in the rocks in suitable situations. The gas is not believed to be generated continuously, but merely to be stored in porous or cavernous rocks overlaid by impervious strata. When these collections are tapped the gas is set free, but a new supply is not being formed to take its place. The position at which the gas is found is very variable, depending upon the force of gravity, and upon the position of the porous layer in which the gas is confined. The lecturer entered into an accurate description of the localities in which the gas was found, and gave the reasons why it was hopeless, from geological grounds, to look for natural gas east of the Alleghenies. The regions in which the gas is found is practically embraced in that portion of Pennsylvania west of the Allegheny mountains, and extending a short distance into Ohio, New York, and West Virginia, and it is also stated to have been found in a very limited extent in Illinois and Kansas.

The most important economic locality is that in the immediate vicinity of Pittsburgh, which supplies that city with the fuel for the vast iron and glass works and for numerous private dwellings. There are six natural gas companies in that city, managing 107 wells, and supplying the gas through over 500 miles of pipe, of which 232 miles are situated in the city proper. The total area of pipe leading into Pittsburgh is given as 1,346,608 square inches, and the total capacity of the lines is estimated at over 250,000,000 cubic feet of gas per day. The largest company is the Philadelphia Natural Gas Company, which supplies over 400 manufactories and over 7,000 dwellings with the entire amount of fuel consumed. The composition of natural gas varies greatly, both in specimens from different wells and in those from the same well at different times. In general terms it can be described as a mixture of hydrogen, nitrogen and marsh gas, with occasionally higher carbon compounds. It burns with a nearly colorless flame, and gives off no odor or deleterious matter.

In speaking of the use of natural gas for domestic purposes, Mr. Ashburner pointed out the great advantages which a gaseous fuel has over a solid one like coal, and stated his belief that the greatest of the advantages of the discovery of natural gas was that it had proven the great economy and practical utility of such fuel. A thousand cubic feet of gas was calculated to equal in heating capacity 55 pounds of coal. He stated that the use of natural gas for domestic purposes would not have been possible without the inventions of Mr. Westinghouse, of Pittsburgh, two of whose inventions the lecturer illustrated. One of these inventions was intended to prevent leakage from gas pipes, and to locate leaks accurately when they occurred. The leaking gas is conveyed to the nearest lamp post and there consumed. Another invention was a most ingenious pressure regulator, which not only regulates the pressure at which the gas is supplied to the burners, regardless of the pressure in the mains, but in the event of the pressure in the mains dropping to zero automatically shuts off all gas from the house; nor is it possible to turn the gas on again without violence to the regulator until every source of escape of gas larger than a pin-hole leak has first been corrected. A model of the regulator was exhibited. The lecture was illustrated by drawings and maps, and by a small working model of a well-boring apparatus.

In answer to inquiries the lecturer stated that the source of natural gas was certainly capable of exhaustion, but that he did not think there was any imminent danger of such a calamity. The sources of supply would certainly last many years, and he believed that before they would give out a method of producing an artificial gas would be invented which would perfectly supplant the present natural gas. The cost of natural gas could not be compared with our coal gas, for the reason that the natural gas was not sold by meter. The consumer makes a yearly contract with the company to supply him with light or fuel, or both, at certain rates. A house containing twelve rooms costs, to heat and light, from \$70 to \$90 a year. The use of the gas is most satisfactory, for by means of an automatic regulator every room of a house may be kept at a temperature not varying two degrees, regardless of the condition of the outside temperature or the pressure on the mains. Defects and troubles were met with from lack of understanding how to properly regulate the supply or the combustion.

In reply to the question as to whether he thought it wise for the city of Philadelphia to lease the gas works for a term of years, Mr. Ashburner re-

plied that, as a business man, he would say that any scheme for supplying the ordinary form of coal gas was, at the present time, extremely uncertain as a business venture. He believed that a very short time would demonstrate that there was a method of generating a fuel gas which would totally supplant all present modes of heating, and that electricity had already solved the problem of illumination. We were in a transition stage with regard to both heating and light, and for these reasons, and from this standpoint, he would regard any movement as undesirable at this time.

Naphtha as an Enricher.

By A. S.

There seems to be wide difference of opinion among gas engineers as to the value of naphtha as a producer of gas. While some will treat it with scorn and contempt, and hold that it will not yield a true gas, but merely vapors which will, when used to enrich coal gas, condense, or cause the gas to smoke, or to stratify, etc., etc., others will attribute to the same naphtha mysterious powers, and expect it to do wonders even when used in quantities ever so small.

We have all read of the Ohio man who lately announced his invention for turning one barrel of oil (weighing, say, 300 lbs.) into 450,000 cubic feet of a brilliant gas, weighing some twenty odd thousand pounds.

In the issue of the AMERICAN GAS LIGHT JOURNAL,* of Dec. 16th, 1886, we further find results obtained from naphtha as an enricher of coal gas at the Laclede Gas Works, St. Louis, Mo., which, while falling far behind the Ohio man's achievements, still are rather astonishing.

It appears, from the statements published in the JOURNAL, that a ton of Yonghiogheny caking coal yielded 10,953 cubic feet of 17-candle gas, the density of which may be assumed to be 0.430. The oil used for enriching purposes is stated to be 62° Beaumé, a gallon of which would weigh about 6 pounds (commercial naphtha 68°-72° B., weighing 5½ pounds per gallon).

Taking up the results obtained in Sept., 1886, we find that a ton of mixture contained 4.8 gallons = 28.8 pounds of naphtha, and 2,240-28.8 = 2,211.2 pounds of coal, and yielded 12,163 cubic feet of 19.66-candle gas, the specific gravity of which not being given may be assumed to be 0.465, allowing a rise of 0.013 in density for an increase of one candle. The weight of the 12,163 cubic feet of gas is, then, 12,163 × 0.465 × 0.0766 = 433.23 lbs.

The gas obtained from the 2,211.2 pounds of coal amounts to 10,812 cubic feet, weighing 10,872 × 0.430 × 0.0766 = 356.12 lbs.

Then we have—

Weight of gas obtained from 1 ton of mixture.....	433.23 lbs.
Less " " " 2,211.2 lbs. of coal.....	356.12 "
—————	
Leaving weight of gas from 28.8 lbs. of oil.....	77.11 "

Even allowing that every particle of the oil had been converted into gas, there would remain 48.21 pounds of gas, the source of which cannot be discovered in the above-quoted statement.

Or, putting it in another way, we have the weight of the 12,163 cubic feet of the enriched gas equal to the weight of gas obtained from 2,211.2 pounds of coal (356.12 lbs.), plus weight of gas obtained from 28.8 pounds of oil, making 384.92 pounds. The specific gravity of this enriched gas would then be—

$$S = \frac{384.92}{12163 \times 0.0766} = 0.413,$$

from which it would appear that the gas decreased in density from 0.430 to 0.413, while its luminosity increased from 17 to 19.66 candles. This runs exactly counter to all heretofore accepted theories about the density of gases in relation to their illuminating power (water gas excepted).

If a gallon of commercial naphtha (5½ lbs. per gal.) could be entirely converted into a fixed gas, without any loss by tarry condensation, or by formation of carbon, or lampblack, it would yield 5½ lbs. of gas, equal to 88.3 cubic feet, the density of the gas being 0.850. As a matter of fact there is considerable loss during the distillation, fixing and cooling of the naphtha gas, no matter what process is used. A yield of 80 cubic feet of 70-candle gas is probably the best that can practically be obtained, and that only by careful working. The heavier oil used at the Laclede works will hardly give better results.

Applying this yield per gallon of naphtha to the example furnished in the statement quoted above, we have—

Gas from 2,211.2 lbs. of coal = 10,812 cu. ft. × 17 candles =	183,804 can. ft.
" 4.8 gallons of oil = 384 " × 70 " =	26,880 "
" 2,240 lbs. of mixture = 11,196 " × 18.82 " =	210,684 "

11,196 cubic feet of 18.82-candle gas would, then, seem to be all that could be expected from such a mixture.

* See page 363.

The Gas Companies and the State.

The leading editorial in the issue of *Iron Age*, dated December 23, 1886, was as follows:

The animated discussion in business circles and in the newspapers of the Reagan-Collum bill has again brought prominently before the public the delicate question of defining the limits of State interference in the relations between the public on the one side and corporations operating under charters on the other. As is usually the case, the extremes are now only heard, and the representatives of the railroads notably are prophesying destruction to great vested interests and ruin to important business interests. We are inclined to be skeptical on these points, and cannot help believing that before many years have passed there will be a revolution among railroad men similar to that which has been quietly going on among gas managers. Gas companies formerly had the distinction of being among the first upon which the dislike of the public descended. They have certainly themselves to blame for it principally, and many of them have keenly felt the result of it through the eagerness of town authorities to give privileges to the first one who promised them the blessing of competition. Too many of those who took advantage of the antagonism of the public were men whose aim was to force the older companies to buy them out. The majority of the latter have suffered from this kind of blackmail and have grown tired of it. From an attitude of defiance, alike dangerous to themselves and to consumers, they have reached quite a different point of view. The public, too, has learned by bitter experience that to welcome sham competitors is to pay for the excitement of a brief "gas war," and to saddle itself with the interest and profits of two plants instead of one. The gas companies have, therefore, slowly changed front, and, so far as can be judged from the discussion at the meetings of their associations, they have reached the conclusion that a guarantee of immunity from attacks is worth to them many concessions which formerly would have been denounced as the crazy claims of demagogues. The gas companies seek this protection through the agency of State Gas Commissions. An interesting discussion of the subject from their point of view followed the presentation of a paper by Mr. Geo. G. Ramsdell, before the last meeting of the American Gas Light Association. We may confess that the paper itself and the tone of the discussion following it, as printed in a number of recent issues of the AMERICAN GAS LIGHT JOURNAL, were a revelation to us. His views are almost radical, and yet speaker after speaker rose to support them or to emphasize some of the points deserving of consideration.

The situation is regarded by the greater number of progressive gas men as follows: We have in the past made serious blunders in neglecting to consider the fact that our investments are largely in the nature of permanent sinking of capital in plant which cannot be removed or be made available for any other purpose. While possessing a monopoly, abuse of the power thus given is likely to thus create opposition more or less reasonable. This finds expression in the form of encouragement to rivals, with whom often the most profitable part of the business must be shared, or the alternative be chosen of buying partly unnecessary plant, and paying profits to hostile promoters. So widespread has this source of loss become that gas companies not yet attacked formerly believed it sound policy to accumulate a fighting fund. To press the maximum dividends on copiously watered stocks seemed to be the sole ambition of the management. Now the progressive men in the business recognize the folly of what was once a general tendency. Practically they say: "We are willing to put the details of our business before a State Commission as the representative of the consumers, to convince them that we are ready now and in the future to deal fairly with the public. All we want is a fair profit on money actually invested, a moderate allowance for reserve and surplus, and a sliding-scale arrangement by which the gas company is given a share in the distributive profits in proportion to the advantages accruing to the consumer in cheaper rates." As an equivalent they ask that they be guaranteed against competition, or, in other words, that they be given a monopoly, though the latter term is carefully avoided, probably because to many it has an odious ring.

So far as the interests of the public are concerned the principles embodied in the new movement of the gas managers are sound. We have already alluded to the fact that sham competition and the sinking of excessive amounts of capital in gas plants prejudice the interests of the consumer in the long run. If sure that they are paying only a fair profit on honestly-invested funds, and that they are to share in the benefits which increased consumption and reduction in costs bring with them, the consumers will be content to abide by their part of the bargain. The leading principles being mutually acceptable, the main question becomes the elaboration of details. During the discussion of the subject at the meeting alluded to a glimpse of the difficulties which would be encountered in this work was obtained when a figure had been named which some considered a fair rate of profit to shareholders, based on capitalization and sales. It became at once evident that what would prove an inadequate return to a company in a small town would

yield enormous profits to concerns furnishing our large cities with illuminating gas. Some distrust was shown concerning the possible *personnel* of gas commissions, and doubts of the same character might arise, too, in the public mind. Massachusetts has had such a body for some time, and the unanimity and vigor with which representatives of that State spoke in favor of the institution nearly carried the Association to the point of passing a resolution favoring their establishment in different States. It is evident, therefore, that whatever difficulties may exist they are not insurmountable. It is, we believe, a very encouraging sign when many thoughtful men representing a great interest have reached the conclusion that their own welfare, as well as that of the public, is so nearly identical that they seek the protection and co-operation of the State from which they have derived their franchise. It is beginning to be recognized that State interference in private affairs is one thing, and that the regulation of the service of corporations created by the State and endowed by it with special privileges is quite another thing. We cannot but believe that the convictions of the managers of our railroad corporations will soon undergo a change in the direction in which the gas men have been progressing so rapidly of late.

Experiments on Flame.

The London *Journal* notes that in a recent number of *Nature* Mr. G. J. Burch published the results of some further experiments on flame, in continuation of those recorded in an earlier issue of that periodical. In his first article he showed that there are two classes of continuous spectra—viz., those due to an incandescent precipitate (in which case the flame has the power of reflecting and polarizing light), and, secondly, flames that do not possess any reflecting power, but give a soft continuous spectrum without maxima or minima. Of the second class is carbonic oxide, which gives at normal pressures a fairly bright spectrum, and at increased pressure—according to Dr. Frankland—a very bright continuous spectrum. Mr. Burch has recently observed its spectrum under reduced pressure, using for his purpose an apparatus similar to that described by Dr. Frankland in his "Experimental Researches." He had considerable difficulty at first in keeping the flame alight at anything like low pressures; and finally he adopted a glass jet, of a trumpet shape, increasing very gradually from 1 millimeter to 3 millimeters in diameter, the flame being further shielded from draughts by a wide disc of cork 10 mm. below the mouth of the jet.

Having carried out his experiment with carbonic oxide (which it is unnecessary to reproduce), he repeated Dr. Frankland's experiment of burning coal gas in air under reduced pressure. Dr. Frankland found that at 6 inches pressure the last trace of yellow disappears from the summit of the flame, leaving the latter an almost perfect globe of peculiar greenish-blue tint. But he used a jet contracted at the mouth to 1.5 mm. Mr. Burch, however, with his much wider trumpet-shaped jet, could, by turning on more gas, produce smoke at 160 mm., so as to blacken the glass chimney. At 120 millimeters the light was noticeably less vivid—the flame having a diluted appearance; but the spectrum showed the usual carbon lines much more sharply defined, the mantles being very much thicker than at normal pressure. With this exception there was no difference caused by the reduction of the pressure to 60 mm.; and even then on turning up the gas a little the ellipsoidal flame became pointed, and the yellow light, giving the incandescence spectrum, reappeared in the tip of it. Mr. Burch thinks it is evident that the trumpet-shaped jet allows carbon to be precipitated in the flame at much lower pressures than the contracted jet. One phenomenon observed by Dr. Frankland the writer was disappointed not to see. The Doctor says: "Just before the disappearance of the yellow portion of the flame there comes into view a splendid halo of pinkish light, forming a shell one-half inch thick around the blue-green nucleus. * * * The color of this luminous shell closely resembles that first noticed by Gassiot in the stratified electrical discharge passing through a nearly vacuous tube containing a minute trace of nitrogen." He does not speak of having used the spectroscope to determine the nature of this pink glow. Mr. Burch went considerably below the lowest pressure mentioned by Dr. Frankland—viz., 4.6 inches—but entirely failed to reproduce it. But he has noticed that very small flames from capillary tubes, observed under a power of 100 in the microscope, are sometimes tinged with rose color in the outer mantle, from a very faint trace of sodium orange light mingling with the blue of the soft outer mantle; and he thinks the jet used by the Doctor, or the glass chimney, may have been sufficiently heated to give a rosy tinge to the flame. Mr. Burch calls attention to one other point. The appearance of the gas flame at low pressures is, he says, precisely like that of a very small gas flame under the microscope. The inner mantle appears to be bordered with bright green light, due to the principal green band of the carbon spectrum extending slightly further than the others. Beyond this, again, comes a zone of violet light due to the band in the violet; and in most cases this extends nearly if not quite to the outer mantle. At ordinary pressures this can only be seen by means of a magnifying glass, except with a special burner;

but the *in vacuo* flame is, as it were, magnified as to its structure, which is thus visible to the naked eye. This fact, in Mr. Burch's opinion, suggests that flames may in a sense obey Boyle's law—*i. e.*, that the space required for complete combustion under given conditions varies inversely as the pressure. He is continuing his experiments, and therefore some further contributions to the general knowledge on this subject may be expected.

Useful Hints for Steam Users.

The *American Engineer* (and it is a pretty sound authority) says that the following figures were obtained from the notebook of an expert English engineer. That being so, users of steam would do well to keep them for handy reference, for investigation will prove that the results have been worked out with great accuracy and skill.

The facts will be found of use for ready reference in calculating the amount of fuel used, saved, or wasted by an engine or boiler in the usual working year of 300 days of ten hours each, and also in a working year of 300 days of twenty-four hours each, such as is the customary run of establishments working 144 hours per week. Each pound of coal per hour per horse power amounts in 300 ten-hour days to 1.33928 gross tons of 2,240 pounds each, and in 300 twenty-four-hour days to 3.21428 gross tons. Each half pound of coal per hour per horse power is 0.66964 gross ton per year of 300 twenty-four-hour days. Each quarter pound of coal per horse power is 0.23482 gross ton per year of 300 ten-hour days, or 0.80357 gross ton per 300 twenty-four-hour days. Each eighth pound of coal per hour per horse power is 0.16741 gross ton per year of 300 twenty-four-hour days. The gross ton of 2,240 pounds aveirdupois is given in these calculations.

To reduce gross tons of 2,240 pounds to net tons of 2,000 pounds, multiply by 1.12 or divide by 0.8928, whichever is more convenient, and conversely. To reduce net tons of 2,000 pounds to gross or legal tons of 2,240 pounds, divide by 1.12, or multiply by 0.8928, according to convenience. In the application of the foregoing figures, suppose a condensing steam engine to develop 175-horse power with 40 pounds initial pressure above atmosphere, with a coal consumption of 3½ pounds per hour per horse power, and that by increasing the initial pressure to 50 pounds by the gauge, the work was 185-horse power, with a coal consumption of 2½ pounds per hour per horse power, the saving per year of 300 ten-hour days is 0.66964 gross tons for each horse power, or 0.66964 = 126.2834 gross tons, and the saving per year of 300 twenty-four hour days is 160,714 by 185 = 297.32 gross tons.

ITEMS OF INTEREST FROM VARIOUS LOCALITIES.

PERSONAL.—On first of January Mr. Geo. H. Cole was appointed General Agent of the Union Foundry and Pullman Car Wheel Works, with headquarters at the Pullman Building, Chicago, Ills. The appointment is a good one.

GAS RATES AT COLUMBIA, PA.—Mr. Robt. Beacham, Superintendent of the Columbia Gas Light Company, writes us, under date of Jan. 6th, that the new schedule (it became operative on October 1st) gives great satisfaction. In accordance with its provisions the net rate to ordinary consumers was placed at \$2 per thousand cubic feet. The bills, as before, are made out at \$2.50, but prompt payment secures a rebate of 20 per cent. Prior to October, '85, ordinary consumers paid \$2.75; between Oct., '85, and Oct., '86, they paid \$2.25; now they are charged but \$2—which scaling proves that Mr. Beacham's directors are inclined to move with the procession.

WASHINGTON (PA.) ALSO IN LINE.—Mr. Jno. C. Hastings, Secretary of the Washington Gas Company, informs us that, at a meeting of the Board of Directors, held Monday, Jan. 3d, the following net schedule of rates was adopted:

A monthly consumption of 900 cu. ft.	\$1.50 per M.
“ “ between 1,000 and 5,000 cu. ft. 1.20 “	
“ “ upwards of 5,000 cu. ft.	1.00 “

This schedule took effect on all accounts rendered on first instant. The prices charged during '86 appear to have been as follows: \$1.50, \$1.30, \$1.20, and \$1. The face of the new scale does not, of itself, show the real importance of the concession just granted; but that it is considerable will be understood when one remembers that the greater number of the Company's patrons must be included in the section embraced by or between the highest and lowest consumption allotments. Further, people who, on a monthly consumption of 5,000 cubic feet of gas, receive their supply in consideration of the payment of \$1 per thousand, are getting it at a rate low enough in all conscience.

THE FINANCE COMMITTEE OF PHILADELPHIA CITY COUNCIL SAYS "NO."—The second offer made by millionaire Wannamaker (it was decidedly more

liberal than even was the first proposition made by him), added to the offer made by a Mr. Henry Bower, which also was exceedingly advantageous to the city, seem to have convinced the Councilmanic Finance Committee of the Quaker City that the gas plant was a pretty valuable thing for the Philadelphia taxpayers to retain control of, even if that control is in the nature of only a partial grasp. At any rate, the Committee, at a meeting held December 27th, decided to report back to Council that all the propositions submitted be rejected. This action may or may not be finally ratified, although the outlook seems to favor the "may" end of the proposition. At all events, Mr. Wannamaker is quite likely entitled to all the credit of having nipped in the bud the nicely-laid plans of the original conspirators, who evidently hoped to acquire, "on easy terms," a veritable bonanza whose content of riches would put to shame the gold and silver bearing lodes that not so many years ago caused the Cemstock ledge to be regarded with wonder all over the civilized world. Perhaps, now that the dawn of reason appears to have manifested itself in the Philadelphia City Councils, we may have ground for hope that the Trust will, by means of needed and judicious expenditure on the Philadelphia gas works, place that plant in proper condition to meet the tremendous strain which not only the future but the present demands of its consumers have put upon it. If Philadelphia will but awake to the possibilities of the occasion she could speedily claim the possession and ownership of the leading gas plant of America, and no mean thing would it be to have the right to so say.

NAMED AS CHIEF ENGINEER.—Mr. Wm. H. Bradley (to whose skill and fidelity, more than to those of any other single man, can the wonderful success of the former management of the Municipal Gas Company of this city be ascribed) was, on date of Jan. 1st, formally appointed Engineer-in-Chief of the Consolidated Gas Light Company. The word "formally" is used because it has long been an open secret that virtually Mr. Bradley was considered to be the Chief Engineer of the Company. To show what an enormous business is being done by the Consolidated Company we may mention that on more than one 24 hours this winter the aggregate sendout from two of its stations amounted to somewhat over 13 millions cubic feet. Mr. Bradley, it will therefore be seen, cannot be accused of having attained a sinecure's berth, and it goes without saying that, as in the past, his employers can count upon him for faithful, intelligent, and untiring effort.

BROTHER EGNER AND HIS VARYING EMOTIONS.—Mr. Frederic Egner, Supt. of the Laclede Gas Light Company, may be said to have recently experienced, and within unmistakably short compass, a remarkably thrilling series of emotions. The inciting cause or causes seem to have been something like the following: Last spring it will be remembered that the Laclede people, in common with many others of the fraternity, had a good deal of trouble at the hands of the strikers, and although Brother Egner speedily "knocked spots" out of his section of malcontents, the latter, while submitting then to the inevitable, warned the victors (meaning Egner more than anyone else) that they, the strikers, would have their revenge when the dark days of the winter season were at hand. December 31st was a pretty bad sort of day—for gas consumers—in St. Louis, and the Laclede's benches were all under fire. So, when the Superintendent saw a large body of his men drop their tools and start of to a particularly roomy section of the retort house, he naturally enough felt a cold chill run up underneath his ulster (the chill might, of course, be charged to the state of the thermometer, for at that time the mercury was busily engaged in an attempt to find a crack in the bottom of the bulb), and he at once, and in terror, recalled the threat of vengeance. One of the foremen was asked if the men were about to repeat the experiment of the spring season, and the foreman replied that he did not know. The Superintendent thought it best to at once hear the worst, and off he posted after the seeming strikers. Before catching up with them he was intercepted by a messenger from the office, who hurriedly said that Mr. Egner was wanted at once by the President of the Company, that gentlemen being anxiously waiting for him at headquarters. Now, indeed, the blow had fallen. There could no longer be any doubt, for as he turned to retrace his steps the malcontents followed suit. The Superintendent noted that many of the men had already assembled in the office, and the door had no sooner closed on him than it opened again to admit the delegation which had followed in his wake. Only one moment of suspense, and the cause of the assemblage was made plain. One of the clerks on the works stepped forward and in good, plain English informed Mr. Egner that the employes of the Laclede Company wished to show him what they thought of him; and after the speaker had painted that feeling through the medium of a few well-chosen words, he accentuated the painting by presenting Mr. Egner with a magnificent array of solid silverware, elegantly chased and appropriately inscribed. The set included a massive tray, on which reposed a complete breakfast and tea service. To say that the recipient was surprised is to put it in the mildest possible manner; but seemingly *sans peine* he accepted the altered conditions, and also accepted the gift in the spirit with which it was

offered. Now more than ever we may expect that Brother Egner, in common with the sage of earlier days, gives adherence to the prediction that no cloud, be it ever so dark, may be said not to carry within it a silver lining.

CHEAPER GAS FOR KINGSTON, CANADA.—We understand that on the 1st inst. the proprietors of the Kingston Gas Light Company authorized a reduction of 50 cents per thousand in the selling rates.

JUDGE MORAN HANDS DOWN A DECISION.—A special to the New York city *Times*, dated Chicago, Ill., Jan. 6, contains the following: "A decision was filed to-day in the Appellate Court, by Judge Moran, in the case of the Peoples Gas Company against the Chicago Gas Light and Coke Company. This was a bill to restrain the Chicago Company from laying mains in the west division of the city in violation of a contract made between the two companies years ago, whereby they were not to invade each others territory. The Court below held that the contract was in violation of public policy, as tending to establish a monopoly, and dismissed the bill for lack of equity. Concerning the question of the legality of the contract referred to, the Appellate Court says in effect that as under its charter the Chicago Company was not limited in its field of operations, and was free to exercise its franchise in the west division if it saw fit, it was equally free not to exercise its franchise in that part of the city, and to contract not to so exercise. On the question of public policy the Court says that 'an agreement in general restraint of trade is contrary to public policy, but an agreement in partial or particular restraint is good when the consideration is good and the restrictions reasonable.' The decision is considered a remarkable one." The future proceedings in this case will be looked forward to by gas men with great interest, for a decidedly vital principle is involved in the suit.

A BURNER COMPANY.—The Mead Regenerative Gas Burner Company, to have its principal place of business located in this city, was chartered on Jan. 5. The capital is fixed at \$250,000.

AN ITEM FROM LINCOLN, ILLS.—Mr. S. A. Foley, of the Lincoln Gas and Electric Light Company, writes that he has made a contract with the city under the terms of which the Company binds itself to charge \$20 per post per annum for street lights that are extinguished at 11:30 P.M.; \$30 per post to be paid for lamps that burn all night. The Company is to light and extinguish, and the city agrees to pay a certain fixed sum toward the making of necessary repairs. The contract is to run for five years, and to begin with 1st inst. Mr. Foley adds that the Company enjoyed a prosperous year; and we cannot see how it could well be otherwise, for President Foley gives close and intelligent attention to its management.

SOMETHING FROM IRONTON, OHIO.—Mr. W. W. Prichard, who controls the business management of the Ironton Gas Company's affairs, is meeting with that measure of success which comes to those who heed their opportunities. In a letter recently received by us from him Mr. Prichard says: "The sliding scale adopted here last March has given great satisfaction, both to the consumers and to the Company. The past year, against considerable prejudice, and in face of the fact that coal costs but six cents per bushel delivered, we decided to attempt to introduce gas cooking stoves. As an incentive we fixed the price of gas to those using gas cooking stoves at \$1.80 per thousand cubic feet, a discount of 5 per cent. being granted in consideration of prompt payment. The rate applied to all gas that passed through one meter, from May 1 to November 1, but did not become operative unless 1,000 cubic feet was consumed in each 30 days. The success which attended the initial attempt was such that the directors subsequently decided to reduce the price for gas used in heating and cooking stoves, gas engines, and for all mechanical purposes, to \$1.60 per thousand, with 5 per cent. off for prompt pay, the last rate going into effect on November 1. Comparing the monthly bills of consumers, from the time that they commenced to use the stoves, with the statement for the corresponding months of the previous year—most of the stoves were put in during July and August—the total gain for cooking stoves alone was shown to have been 51,900 cubic feet. Three gas engines and one tobacco sweater developed a gain of 18,200 cubic feet, or a total of 70,100 cubic feet for our first year's work. It took considerable effort on my part to induce our directors to permit me to try the gas stove business, and the President said if I could place 10 stoves he would be satisfied. A count shows that 22 cooking and 6 heating stoves, 2 gas engines, and one tobacco sweater had been installed up to December 16, 1886. The prospect seems good for 50 stoves, and additional gas engines, for next summer. Your readers may be interested to hear something further in the matter of our leakage account, as a supplement to the paper* read by me at the Springfield meeting of the Ohio Association. In first eleven months of

1886 we manufactured 46,920 cubic feet less than during the same period last year, but sold 417,028 cubic feet more. In connection with this our storekeepers, with the exception of the druggists, were seized with an early closing fit, and shut up their places of business at 7:30 P.M. Besides that the street or public lamp schedule was also decreased. Under such adverse circumstances we do not regret the reduction granted to consumers, and when everything is figured up there will be only a slight difference in net profit for the year. However, having everything about the plant in good working order naturally tends to lessen the cost of manufacture. We put in a bench of fours on the generator plan, with deep furnaces, in an old arch, and the result is that we can make more gas this winter in that bench of fours, assisted by a poor bench of fives (the latter will be abandoned in February), than we could last winter with the now poor bench of fives (it was new then), one bench of threes, and one bench of fours, both in fair order. We also have a greater quantity of coke to sell."

Mr. Prichard's practice could be imitated with profit by many others of the craft who are similarly situated. Ironton is not a particularly large town, and what was accomplished there can be done elsewhere. Of course, it may require the expenditure of some energy; but everyone who desires to succeed must expect to at least pay that price for success.

CHANGE IN FIRM NAME.—Mr. Henry Maurer, Proprietor of the Excelsior Fire Brick and Clay Retort Works, whose manufacturing plant is at Perth Amboy, N. J., and with sales headquarters at 420 East 23d street, this city, announces that his son has been admitted to a partnership in the firm. The title of the firm hereafter will be that of "Henry Maurer & Son."

AT REST.—We are called upon to chronicle the death of Mr. E. M. Van Kleeck, late President of the Poughkeepsie (N. Y.) Gas Light Company, whose demise occurred on Thursday, Jan. 6. Mr. Van Kleeck became President of the Poughkeepsie Company in 1878, and his administration of its affairs gave satisfaction to its owners. Deceased was in the 74th year of his age, and was a representative citizen of the city in which he dwelt. The funeral service was held on Sunday, Jan. 9.

ONE DAY'S SENDOUT AT POUGHKEEPSIE, N. Y.—For the 24 hours ended December 24th, 1886, the sendout of the Poughkeepsie Gas Light Company amounted to 106,000 cubic feet. That figure had not been exceeded since 1878.

NEW GAS COMPANY.—The Pittsburg Gas Light and Coke Company, of Pittsburg, Kansas, has been chartered. It is officered as follows: President, O. T. Boaz; Vice-President, Frank Playter; Treasurer, F. W. Lanyon; Secretary, W. D. Ford. The Board of Managers invite the various firms engaged in gas works construction to communicate at once with them.

HOLDER FOR THE LONG BRANCH (N. J.) GAS COMPANY.—Mr. T. F. Rowland, proprietor of the Continental Iron Works, Greenpoint, N. Y., is now engaged on the construction of a new gasholder for the Long Branch Gas Light Company. The holder is calculated to have storage capacity of 100,000 cubic feet, and will be suspended over or in a wrought iron tank. It will have six wrought iron columns, is calculated to give a maximum pressure of 3½ inches, and will be finished by April 1st.

MR. GLENN, OF CINCINNATI, OHIO.—We believe that Councilman Glenn, of Cincinnati, Ohio, ought to be "disciplined," for he certainly deserves "correction." Glenn was one of those who opposed the ordinance recently passed by the Cincinnati Council, in the nature of regulating rates to be charged by the Cincinnati Gas Light Company during the next ten years, and that opposition, of course, could not be objected to provided the objector adhered to the truth. Glenn originally urged that three gas companies in Chicago were charging only \$1 per thousand cubic feet for gas supplied by them, and that statement was at once contradicted by General Hickenlooper. Glenn then wrote to Mr. Forstall, of the old Chicago Company, asking the latter to post him in the matter of current gas rates at Chicago. Mr. Forstall made the following reply:

"The net prices charged by the various gas companies in Chicago are as follows: Chicago Gas Light and Coke Company, \$1; Consumers Company, \$1; Peoples Company, \$1.50; Hyde Park Company, \$1.75; Lake View, \$1.50; in South Chicago, \$1.75. It must be borne in mind that the dollar rate in Chicago is a 'fighting price,' which has in two years brought one of the contestants into bankruptcy." If Glenn had any decency at all about him one would suppose that he would recant his former statement; but Glenn is not that sort of an opponent, for, in a letter of his published in the *Commercial Gazette*, at the time when he had Mr. Forstall's reply in his possession, he said: "I reassert and am prepared to prove my former statement that there are three companies in Chicago selling gas at a dollar per thousand cubic feet." In other words, he was prepared to reassert that which

* See JOURNAL, May 17, 1886, page 283—"A Year's Experience in a Gas Works," by W. W. Prichard.

he knew to be utterly false. There seems to be no difference in the makeup of a certain percentage of our city fathers, no matter where these exercise their "parental guardianship." New York, Buffalo, Brooklyn, Cincinnati—the "certain percentage," sooner or later, may be trusted to float to the surface.

FRISKY NATURAL GAS.—The Natural Gas developments have undoubtedly contributed greatly to the wealth of the country, but we have plenty of evidence that such development has been attended with injury to person and destruction of property. Perhaps the Kokomo affair, of December 17th, and the Youngstown explosion, of Jan. 5th, will serve to show what we refer to. Here are but two cases, yet we find that 35 persons were, according to the despatches, more or less injured at Kokomo, and that \$100,000 will not cover the monetary loss sustained at Youngstown. Two lives lost must also be charged to the latter happening.

THE BROOKLYN (N. Y.) ELECTRIC LIGHT CONTROLLERS.—At a meeting of the stockholders of the Citizens Electric Light Company (held January 5th) Messrs. Chas. Cooper, Jno. Delmar, Anthony Barrett, Hugh McLaughlin, and T. F. Nevins were selected as a Board of Directors for the ensuing year. After looking over that list it is not hard to understand why the light of the future blazes out in solitary grandeur on the lone hilltops of the Park slope, over the odorous piggeries of the "Hook," and the classic precincts of the sections known by divers national appellations. Edison made a mistake (that is, if his remarks were intended to apply to Brooklyn along with the rest of the world) when he said that "electricity was the light of the rich," for the Brooklyn magnates, with an impartiality quite foreign to their practice in other respects, have decided that rich and poor must bask alike in the glare of the arc. In the meantime the ring receives \$182.50 per annum for each 1,000-candle power lamp maintained, and it may be added that rich and poor have an opportunity to pay the bills. Some of those who ought to know whereof they speak assert that a Grand Jury of the future will be called upon to investigate certain items connected with the electric lighting of the City of Churches. It won't do any good, however; for the metal out of which the ring is composed becomes heavier and stronger with the lapse of time. All Brooklyn's taxpayers seem to be able to do is to watch and wait, and the trouble seems to be that they will never understand the inutility of such a process. The ringsters thoroughly appreciate the situation, and how deftly they take advantage of it.

GOING AHEAD.—Last December the Concord (N. H.) Gas Light Company sold 2,724,000 cubic feet of gas, or 170,000 cubic feet in excess of the returns for December, 1885. The Concord folks are about to add an electric plant to the existing gas works.

PRICE OF GAS AT BRUNSWICK, GA.—Gas is now sold in Brunswick for \$2.50 per thousand. The Company will do better than that before long.

STREET LIGHTING AT BAYONNE, N. J.—At a meeting of the Bayonne Common Council (held Jan. 4th) a resolution was adopted to instruct the City Attorney to draft a contract with the United Gas Improvement Company—which now controls the Bayonne and Greenville Gas Light Company—of Philadelphia, Pa., to light 525 street lamps, at \$20 per annum each. This is said to be a reduction of \$5 per post from the rate formerly charged. The Improvement Company agrees to furnish a gas having 22-candle power.

TO ABANDON WATER GAS.—The Rochester *Post-Express* says that the manufacture of water gas at the works of the Clyde (N. Y.) Gas Company is to be abandoned.

GAS COMPANIES BIDDING FOR WHAT IS LEFT.—During the last week in December the City Works Commissioner, of Brooklyn, N. Y., opened the bids submitted by the local gas companies for lighting the streets in 1887—that is, for such portion of the lighting as will remain when the "ring" electricians are awarded their share:

Company.	Per post.
Citizens.....	\$22.00
Williamsburg.....	21.75
Peoples.....	22.00
Metropolitan.....	22.00
Nassau.....	22.00
Brooklyn.....	19.80

These figures are about (if not quite) the same as those handed in a twelve-month ago. If anything (except in case of the Brooklyn Company) the figures are too high for the duty exacted.

TO COMPEL A REDUCTION.—The legislators at Albany seem determined to ruin one or two of the Brooklyn gas companies, for that event is sure to take place—at least so we are told—if the bill already introduced, which seeks to

limit the price to be charged to \$1.50 per thousand cubic feet, be enacted into law. The nominal rate at present is \$2 per thousand.

TO LIGHT THEIR ROADWAY.—The ordinance granting the L. C. & D. Railroad the right to run through Hamilton, Ohio, contains a clause which obliges the road to erect lamp posts and light with gas that portion of the road within the city limits. Wherever possible every railroad corporation in the country ought to be made to do likewise.

PROPOSAL TO ESTABLISH A GAS WORKS.—Ohio parties (names at present unknown to us) made a proposition to the City Council of Lamar, Mo., on the evening of Jan. 3d, to erect and maintain a gas plant in that town provided the authorities would agree to maintain 40 lamp posts, and pay therefor the sum of \$30 each per annum; and further provided that the applicants be granted an exclusive privilege for 30 years. The matter will be decided this evening. Lamar is the capital seat of Barton County, Mo., on or near Spring river, and is about 38 miles southeast of Fort Scott, Kansas. It has a population something short of 4,000.

EATON'S EXPERIENCE.—Eaton, Ohio, attempted to illuminate her streets by means of two tower and four separate arc lights, suspended over the four principal crossings of the town. The current was turned on with dusk of Christmas eve., and one who witnessed the attempt said that the place, which is quite small, was better lighted when gasoline alone was used, and the latter plan cost \$400 a year less than the present system will.

ADDRESS CHANGED.—Prof. Henry Wurtz has removed his offices and laboratory from 333 Second avenue, to 2,142 Seventh avenue, this city. The new location is close by the 125th street station of the West side elevated system.

AMERICAN SOCIETY OF CIVIL ENGINEERS.—The annual meeting of this Society will be held, on January 19 and 20, at the Society's House, No. 127 East Twenty-third street. Among the other items on the programme for the second day we note that a visit is to be made to Mr. Thos. F. Rowland's Continental Iron Works.

WHAT COLLECTOR MAGONE THINKS OF THE ELECTRIC LIGHT.—The *Commercial Advertiser* has been making some pertinent inquiries concerning the worth and cost of practical electric lighting as witnessed in the metropolis. One of its reporters returns Collector Magone as saying of the incandescent electric light supplied to the Custom House by the United States Company: "The electric lights in my offices are worthless, and I have reported their worthlessness to the Treasury authorities at Washington. If it were not that we have gas fixtures as well we would be in darkness the greater part of the time when we need artificial light. My Secretary is obliged to use candles on his desk." The United States Company maintains 209 incandescent lamps in the Custom House buildings, and the Government pays therefor the sum of \$400 per month.

DECATUR, Alabama, it is said will shortly construct gas and water works.

THE Sheffield (Alabama) Land, Iron and Coal Company asks that builders of gas works communicate with it in reference to the erection of a gas plant at Sheffield.

TO BUILD THE LOWELL (MASS.) HOLDER.—In the competition for the new holder to be erected on the works of the Lowell Gas Light Company the plans and specifications submitted by Messrs. Bartlett, Hayward & Co., of Baltimore, Md., were accepted, and the contract subsequently awarded them. The holder is to have a diameter of 130 feet in outer section, two 30-foot lifts, and a 12-column (wrought iron) suspension frame, with an intermediate belt of latticed girders.

NAMED AS GENERAL MANAGER.—Mr. M. S. Greenough has been appointed General Manager of the American Gas Company, of Phila., Pa. We congratulate the Company on the selection made. Bright, skilful, and the soul of honor, Mr. Greenough will certainly prove a veritable tower of strength to the Company.

SECRETARY BUTTERWORTH'S LIST.—Secretary Butterworth proposes the following list as subjects likely to add interest to the March meeting of the Ohio Association: What are the Advantages of Anti-Seal Appliances for Dip-Pipes in Hydraulic Mains? Will Iron Purification Increase or Diminish Troubles Caused by Naphthaline? Temperature of Retorts; What Amount of Capital per Thousand Feet of Gas put into Holders is Invested in Ohio Gas Works? Photometric Tests of Candle Power; Choked Stand-Pipes—Is there a Remedy? Testing Consumers' Meters; Purification in Small Works; Relative Cost of Coal Gas and Water Gas; The Elimination of Tar Before Gas Reaches the Washer; What is the Proper Location for the Exhauster? Condensation; Cause and Prevention of Stoppage in Burner Tips; Uniform vs. Special Rates for Gas.



A. M. CALLENDER & CO.,

PROPRIETORS.

Editor—JOS. R. THOMAS, C.E.

Asst. Editor—T. J. CUNNINGHAM.

Manager—C. E. SANDERSON.

PUBLISHED ON THE 2ND AND 16TH OF EACH MONTH
At No. 42 Pine Street, New York.

This is a recognized official organ of—
LIGHT, HEAT, STEAM, WATER-SUPPLY,
VENTILATION, SANITARY IMPROVEMENT,
AND GENERAL SCIENCE.

TERMS

Subscription—Three Dollars per annum, in advance.

AGENTS

NEW YORK—AMERICAN NEWS Co. 39 and 41 Chambers St.
BOSTON—S. M. PETTENGILL & Co., 6 State Street.
PHILADELPHIA—PRATT & Co., Corner 9th and Arch Streets.
England—C. W. HASTINGS, 22 Buckingham St., London, W.C.
Germany—B. WESTERMANN & Co., of New York

MONDAY, JANUARY 17, 1887.

The Market for Gas Securities.

The market for city shares at present writing is decidedly uneven. Consolidated shows a sharp advance over last quotation given in these columns. Within the fortnight top price was reached at something short of 83, but subsequent reaction forced the shares down to 80, and from thence a rising tide restored quotations to between 81 and 81½. Equitable is lower, at 112 asked, which is one point below former bid price, although it should be remembered that these shares are now ex-dividend of 2 per cent., paid Saturday last. Mutual is weak, despite the payment of a 2 per cent. dividend on 10th inst. At auction, we note sale of 70 shares Mutual, at 100, and \$3,000 bonds, at 102½. On last Wednesday the Harlem station of the Consolidated was put once more in duty, and although it is claimed that the excessive demand for gas in that section necessitated the process of revival such statement must be taken with a grain or two of salt. The Company managed to get along without assistance from the Harlem branch during the period of heaviest winter output, and putting one thing with another, perhaps the scarcity and dearness of anthracite coal in this vicinity made possible by the lunacy of those grimy sons of toil—the “coal handlers” of New Jersey—about accounts for the present “color” in the Harlem benches. Whether excessive demand or dear anthracite may be chosen to account for the Harlem departure, investors may be certain that Consolidated gas shares are worth more than ruling figures. Brooklyn shares are looking up a bit, and 'tis likely that the scare over them is most ended. At the annual election of the old Brooklyn Company, held Jan. 11th, no change was made in the executive management. The *Globe-Democrat*, St. Louis, Mo. (issue of Jan. 10, 1887), contains a rabid bear article directed to local gas stocks. Eastern holders of Laclede shares, and there are many of them, need entertain no fear of the ultimate result, should a gas war break out in that locality. The Laclede Company will more than hold its own every time. To go back to Brooklyn, the feeling there seems to be now that Senator Griswold's Albany proposition to oblige the Brooklyn Companies to charge not to exceed \$1.50 per thousand cubic feet for gas is likely to fall short of becoming a law. Why this

sentiment prevails can hardly be explained on any better ground than that our legislators, having killed the Metropolitan golden gas goose, will be cautious how they put the knife into the punier Brooklyn waddler.

Gas Stocks.

Quotations by Geo. W. Close, Broker and Dealer in Gas Stocks.

16 WALL ST., NEW YORK CITY.

JANUARY 17.

All communications will receive particular attention.
The following quotations are based on the par value of \$100 per share.

	Capital.	Par.	Bid	Asked
Consolidated.....	\$35,430,000	100	81½	81¾
Central.....	440,000	50	—	—
“ Scrip.....	220,000	—	47	57
Equitable.....	2,000,000	100	110	112
“ Bonds.....	1,000,000	—	113	115
Harlem, Bonds.....	170,000	—	—	—
Metropolitan, Bonds...	658,000	—	110	113
Mutual.....	3,500,000	100	97x	—
“ Bonds.....	1,500,000	1000	101	—
Municipal, Bonds.....	750,000	—	—	—
Northern.....	125,000	50	36	—
“ Scrip.....	108,000	—	—	—
Yonkers.....	—	50	51	55
Richmond Co., S. I.	300,000	50	50	—
“ Bonds.....	40,000	—	—	—
Gas Co's of Brooklyn.				
Brooklyn.....	2,000,000	25	102	103
Citizens.....	1,200,000	20	—	57
“ S. F. Bonds....	320,000	1000	—	103
Fulton Municipal.....	3,000,000	100	—	130x
“ Bonds....	300,000	—	—	106
Peoples.....	1,000,000	10	57	—
“ Bonds.....	290,000	—	100	—
“ “.....	250,000	—	99	—
Metropolitan.....	1,000,000	100	—	75
Nassau.....	1,000,000	25	100	—
“ Cfts.....	700,000	1000	100	—
Williamsburgh.....	1,000,000	50	115	—
“ Bonds... ..	1,000,000	—	107	—
Out of Town Gas Companies.				
Buffalo Mutual, N. Y... ..	750,000	100	90	95
“ Bonds... ..	200,000	1000	95	100
Citizens, Newark.....	918,000	50	130	138
“ “ Bonds.	124,000	—	105	110
Chicago Gas Co., Ills... ..	5,000,000	25	142	145
Peoples G. L. & C. Co., Chicago, Ills.....	3,000,000	—	29	31
Cincinnati G. & C. Co.. ..	—	—	198	200
Consolidated, Balt.....	6,000,000	100	55	57
“ Bonds....	3,600,000	—	107	107½
Chesapeake, Balt.....	1,500,000	100	71	73
“	1,000,000	—	100	102
Central, S. F., Cal.....	—	—	82½	84
Capital, Sacramento, Cal.	—	—	54	56
Consumers, Toronto... ..	1,000,000	50	194½	196½
Hartford, Conn.....	750,000	25	140	142
Jersey City.....	750,000	20	155	—
Laclede, St. Louis, Mo. ..	1,600,000	100	110	112
Louisville, Ky.....	1,500,000	50	126	130
Little Falls, N. Y.....	50,000	100	95	100
“ Bonds.....	25,000	—	100	103
Montreal, Canada.....	2,000,000	100	209	215
New Haven, Conn.....	—	25	190	195
Oakland, Cal.....	—	—	35	36
Peoples, Jersey City... ..	—	—	25	30
“ “ Bonds.. ..	—	—	—	—
Paterson, N. J.....	—	25	90	—
Rochester, N. Y.....	—	50	75	80
St. Louis, Missouri.....	600,000	50	—	475
San Francisco Gas Co.				
San Francisco, Cal... ..	10,000,000	100	60¼	60½
Memphis (Tenn.) Gas... ..	750,000	100	80	82
“ Bonds.....	240,000	100	103	—
Washington, D. C.....	2,000,000	20	190	—
Wilmington, Del.....	—	50	205	215
Havana (Cuba) Gas Co. ..	3,000,000	100	18	20
“ Bonds.....	550,000	—	102	—

Advertisers Index.

	Page
GAS ENGINEERS.	
Jos. R. Thomas, New York City.....	56
Wm. Henry White, New York City.....	56
Wm. Farmer, New York City.....	56
William Gardner, Pittsburgh, Pa.....	56
GAS WORKS APPARATUS AND CONSTRUCTION.	
James R. Floyd, New York City.....	59
T. F. Rowland, Greenpoint, L. I.....	59
Deily & Fowler, Phila., Pa.....	59
Kerr Murray Mfg. Co., Fort Wayne, Ind.....	59
Stacey Mfg. Co., Cincinnati, Ohio.....	59
Bartlett, Hayward & Co., Baltimore, Md.....	59
Morris, Tasker & Co., Limited, Phila., Pa.....	58
Davis & Farnum Mfg. Co., Waltham, Mass.....	16
R. D. Wood & Co., Phila., Pa.....	58
Southwark Foundry and Machine Co., Philadelphia, Pa.....	58
PROCESSES.	
National Gas Light and Fuel Co., Chicago, Ills.....	48
American Gas Improvement Co., Pittsburgh, Pa.....	47
GAS AND WATER PIPES.	
Gloucester Iron Works, Phila., Pa.....	56
Warren Foundry and Machine Co., Phillipshurgh, N. J.....	56
Mellert Foundry and Machine Co., Reading, Pa.....	56
Cincinnati and Newport Iron and Pipe Co., Newport, Ky... ..	56
Ohio Pipe Co., Columbus, Ohio.....	56
Pancoast & Rogers, New York City.....	56
M. J. Drummond, New York City.....	56
GAS ENGINES.	
Schleicher, Schumm & Co., Phila., Pa.....	64
Clerk Gas Engine Co., Phila., Pa.....	50
RETORTS AND FIRE BRICK.	
J. H. Gautier & Co., Jersey City, N. J.....	54
B. Krëischer & Sons, New York City.....	54
Adam Weher, New York City.....	54
Laclede Fire Brick Works, St. Louis, Mo.....	54
Brooklyn Retort and Fire Brick Works, Brooklyn, N. Y.	54
Borgner & O'Brien, Phila., Pa.....	54
James Gardner, Jr., Pittsburgh, Pa.....	54
Henry Maurer & Son, New York city.....	54
Chicago Retort and Fire Brick Works, Chicago, Ills.....	54
Baltimore Retort and Fire Brick Co., Baltimore.....	54
Oakhill Gas Retort and Fire Brick Co., St. Louis, Mo.....	54
Evens & Howard, St. Louis, Mo.....	55
Cincinnati Gas Retort and Fire Brick Works, Cincinnati, O. ..	55
Emil Lenz, New York City.....	55
SCRUBBERS AND CONDENSERS.	
G. Shepard Page, New York City.....	57
REGENERATIVE FURNACES.	
Adam Wcher, New York City.....	55
Bartlett, Hayward & Co., Baltimore, Md.....	55
GAS GOVERNORS.	
Connelly & Co., New York City.....	51
T. C. Hopper, Phila., Pa.....	52
CEMENTS.	
C. L. Gezould, Manchester, N. H.....	47
Howard Fleming, New York City.....	48
GAS ENRICHERS.	
Forest City Naptha Co., Cleveland, Ohio.....	60
GAS METERS.	
Harris, Griffin & Co., Phila., Pa.....	62
American Meter Co., New York and Philadelphia.....	63
The Goodwin Gas Stove and Meter Co., Philadelphia, Pa... ..	63
Helme & McIlhenny, Phila., Pa.....	63
D. McDonald & Co. Albany, N. Y.....	63
Nathaniel Tufts, Boston, Mass.....	62
EXHAUSTERS.	
P. H. & F. M. Roots, Connersville, Ind.....	52
Smith & Sayre Manufacturing Co., New York City.....	58
Wilbraham Bros., Philadelphia, Pa.....	60
Connelly & Co., New York City.....	52
GAS COALS.	
Penn Gas Coal Co., Phila., Pa.....	61
Perkins & Co., New York City.....	60
Newhurgh Orrel Coal Co., Baltimore Md.....	61
Despard Coal Co., Baltimore, Md... ..	61
Chesapeake and Ohio R.R. Coal Agency, N. Y. City.....	61
Westmoreland Coal Company, Phila., Pa.....	61
Monongahela & Peters Creek Gas Coal Co., Pittsburgh, Pa..	61
CANNEL COALS.	
Perkins & Co., New York City.....	60
J. & W. Wood, New York City.....	60
VALVES.	
Ludlow Valve Manufacturing Co., Troy, N. Y.	52
John McLean, New York City.....	52
ENGINES AND BOILERS.	
Jarvis Engineering Co., Boston, Mass.....	47
PURIFYING MATERIAL.	
S. H. Douglas, Ann Arbor, Mich.....	47

GAS LAMPS.	
The Siemens-Lungren Co., Philadelphia, Pa.....	57
G. Shepard Page, New York City.....	23
Albo-Carbon Light Co., Newark, N. J.....	49
Crystal Carbon Light Co., Phila., Pa.....	50
Standard Gas Lamp Co., Phila., Pa.....	48
Geo. H. Gregory, New York City.....	48
PURIFIER SCREENS.	
John Cabot, New York City.....	47
GAS STOVES.	
American Meter Co., New York and Philadelphia.....	53
The Goodwin Gas Stove and Meter Co., Phila. Pa.....	32
STREET LAMPS.	
J. G. Miner, Morrisania, New York City.....	47
Bartlett Street Lamp M'g Co., New York City.....	52
BURNERS.	
G. Gefroerer, Phila., Pa.....	60
STEAM BLOWER FOR BURNING BREASE.	
H. E. Parson, New York City.....	55
GASHOLDER TANKS.	
W. C. Whyte, New York City.....	48
GAS FIXTURES.	
Mitchell, Vance & Co., New York City.....	48
STEAM PUMPS.	
A. S. Cameron Steam Pump Works, N. Y. City.....	55
COKE CRUSHER.	
C. M. Keller, Columbus, Ind.....	61
B. J. Allen, Newark, New Jersey.....	61
COAL HANDLING MACHINERY.	
C. W. Hunt Company, New York City.....	52

WANTED,
A Good Second-Hand
METER PROVER.

Address JOHN STAFFORD, Supt. Gas Co.,
 Meridian, Miss.

SITUATION WANTED

By a Practical Gas Engineer.

For 18 years in charge of very successful operations of a coal gas works. Best of references given. Address

"F. B.," care this Journal.

Superintendent's Position Desired

By a practical man of twenty-five years' experience in the manufacture and distribution of coal and water gas. Satisfactory references given. Address

646-1f "ENGINEER," care this Office.

FOR SALE,

One Station Meter, 5 ft. by 5 ft., in perfect order.
 One 12-in. Station Governor.
 Six Sections of Hydraulic Main, 19 in. by 22 in., for benches of sixes.

Also, Mouthpieces and Stand, Bridge, and Dip Pipes for 6 benches of sixes.

All the above in good condition. Apply to

1658-6t NEWPORT GAS LT. CO., Newport, R. I.

THE GLOBE STREET LAMP.

MINER'S PATENT STREET LAMPS.

Are adapted for use of Streets, Parks, Depots, Ferries, & Private Grounds.

WITH POSTS OR BRACKETS.

Jacob G. Miner,

No. 823 Eagle Ave., New York N. Y.

FOR SALE,
 Ten No. 2 Siemens Regenerative Gas Lamps,
 With Factory Fixtures and Reflectors complete and in order.
 Only used three or four months. Will be sold cheap.
 DANVILLE NAIL AND MFG. CO.,
 Danville, Pa.

FOR SALE,
Gas Works
 IN A GROWING WESTERN CITY.
 Reason for selling, owner's inability to give his attention to the business. Address
 655-8 P. O. Box 438, GREEN BAY, WIS.

GEROULD'S IMPROVED RETORT CEMENT.
 A Cement for patching retorts, putting on mouthpieces, and making up all bench-work joints. This Cement is mixed ready for use. Economical and thorough in its work. Fully warranted to stick. For recommendations and price list address
C. L. GEROULD,
 Manchester, N. H.

ENGLISH
"Journal of Gas Lighting."
 Issued weekly. New volume commences Jan. 1, 1887. Price, \$7 per annum. Subscriptions taken by
CHARLES NETTLETON, Agent for U. S.,
 No. 115 BROADWAY, N. Y. CITY.

JARVIS ENGINEERING CO.,
 61 Oliver St., Boston, Mass.
 CONTRACTORS FOR ERECTING
COMPLETE STEAM OUTFITS FOR ELECTRIC LIGHTING STATIONS.
 Steel Boilers set with Jarvis Pat. Boiler Setting,
 To burn **COKE SCREENINGS** for Fuel.
ARMINGTON & SIMS CO. ENGINES,
 Belting direct to Dynamos, without using Shafting.
SEND FOR CIRCULARS.

Illuminating Gas from Natural Gas,

AS MANUFACTURED UNDER THE

McKAY and CRITCHLOW PATENTS

BY THE

AMERICAN GAS IMPROVEMENT COMPANY, LIMITED.

PRINCIPAL OFFICE,
 6234 Penn Avenue, Pittsburgh, Pa.

BRANCH OFFICES,
 At Titusville and Beaver Falls, Pa.

W. H. DENNISTON, Chairman, Pittsburgh, Pa. }
 W. B. ROBERTS, M.D., Titusville, Pa. } **OFFICERS & MANAGERS.** {
 E. T. ROBERTS, Treasurer, Titusville, Pa. } HUGH MCKAY, London, Ontario.
 J. M. CRITCHLOW, Secretary, Beaver Falls, Pa.
 JOHN MCKAY, Superintendent, Titusville, Pa.

Should the supply of Natural Gas fail, will sell a plant and right to make Water Gas. Practicable at any Gas Works now in operation, and changes made with trifling cost. New apparatus, complete, with capacity of 50,000 to 500,000 feet per day, \$3,000 to \$10,000.

Guaranteed in Agreement to make Good. Cheap. Fixed Gas, or No Pay. Correspondence solicited.

Ferric Oxide for Gas Purification.

Ferric Oxide, as ground, screened, and prepared by me for purifying purposes, has now been in use for several years by many of the gas works throughout the country, including Detroit, Chicago, Milwaukee, East Saginaw, Burlington (Iowa), Ann Arbor, etc. It has proved, as I believe, the Most Effective and Economical Agent now in use. I am prepared to furnish the Oxide by the 100 lbs. or in car load lots, and will be pleased to give price f.o.b. cars at Ann Arbor or at place of destination. Address

S. H. DOUGLAS, Prest. Ann Arbor (Mich.) Gas Light Co.

CHURCH'S REVERSIBLE SCREEN FOR GAS PURIFIERS

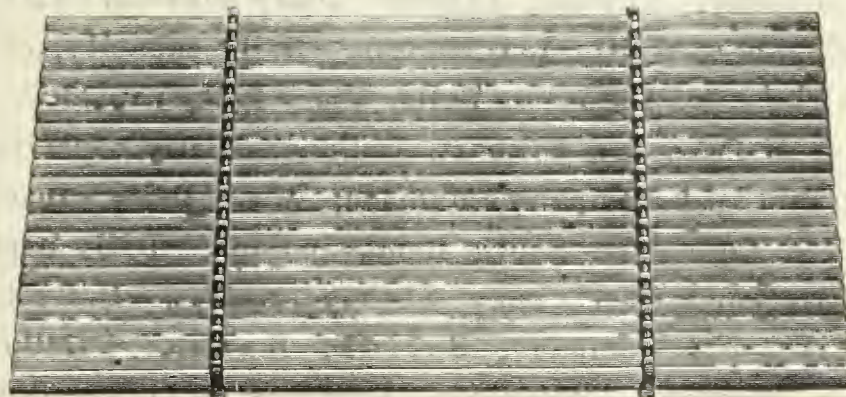

Very Durable
Easily Repaired.

Oval Slats, with
Malleable Iron
Cross Bars.

Apply to

JOHN CABOT,

306 to 310 11th Av., N. Y.

PATENTED JULY 9, 1878.

References in all parts of the country. Send for circular and list of companies who now have the Screen in use.



STEPHEN A. MORSE, President.
GODFREY REBMANN, Vice-Pres.

M. B. DYOTT,
Superintendent.

EDWIN F. MORSE, Secretary.
CARLTON M. WILLIAMS, Treas.

STANDARD GAS LAMP CO.,

Office, 411 Cherry St. Factory, 1101, 1103 & 1105 Frankford Av.

Philadelphia, Pa.

It is to the interest of Gas Companies and Cities to use Dyott's Patent Champion Lamps, which give double the light with the same consumption of gas, and will save 50 per cent. over others in cost of keeping in repair. Gas Companies and others intending to erect Lamps of any description will do well to communicate with us. Special Drawings furnished and Estimates given on application upon Architects', Engineers' or our Draughtsmen's Plans.

Our Patent System of Instantaneously Lighting Gas (without electricity) for R. R. Depots is unequalled. Our High Candle Power Burner is superior to the Electric Light or any other High Candle Burner. We manufacture every description of Ornamental Lamps.

Gregory's Retort Incandescent Gas Lamps.

Manufactured under Patents granted and applied for. Over 20,000 sold in New York and Brooklyn. Over 100,000 sold in the U. S. in one year. It is the only lamp that can compete with Incandescent Electric Light. Gas Companies should see that it is on sale in their city or town. They can be attached to any bracket or fixture. A Complete Revolution in Gas Lighting. The invention of GEO. H. GREGORY, Gas Expert. A pure white light obtained from Gas, which is Superior to Electric Light. All lamps are finished in nickel plate. The construction of all lamps allows the gas to be superheated before passing through the tip, rendering the illuminating properties of the gas incandescent, which causes the Brightest Light ever obtained from Gas. Lamps made in all sizes. Gas Companies should assist in introducing this new lamp, which exceeds all other devices for gas lighting. This Cut represents Office and Bracket Lamp. Price, \$18 per dozen; discount 50 per cent. in half dozen lots or more. Send for Catalogue. Address

GEO. H. GREGORY, Mnfr., 337 Broadway, N. Y.

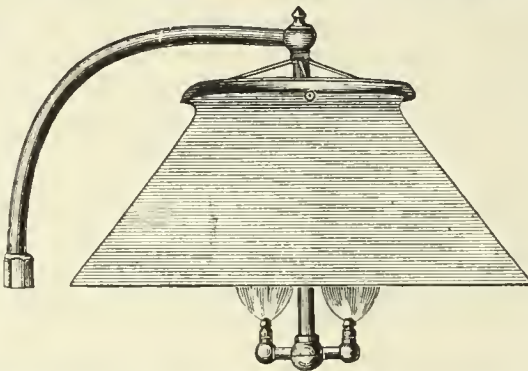

GASHOLDER TANK CONSTRUCTION, ETC.

Gas Companies and others about to erect Gasholders will find it profitable to consult W. C. WHYTE, who for over thirty years has made a specialty of

Holder Tank Excavation and Mason Work.

Fifty tanks now in operation show the sort of work done. Address

W. C. WHYTE, No. 15 Cortlandt St., N. Y. City.

GIBBS PORTLAND CEMENT

Is guaranteed to be the finest English brand, and unsurpassed by any grade imported for making concrete and setting masonry.

Extract of Paper, with tests, read before the American Society of Civil Engineers, sent on application.

HOWARD FLEMING,
Sole Agent for U. S.,
23 Liberty St., New York.

MITCHELL, VANCE & CO.,

MANUFACTURERS OF

Chandeliers

and every description of

GAS FIXTURES.

Also manufacturers of Fine Gilt Bronzes and Marble Clocks, warranted best time-keepers. Mantel Ornaments, etc.

Salesrooms, 836 Broadway, N. Y.

Special Designs furnished for Gas Fixtures for Churches, Public Halls, Lodges, etc.

HOWARD FLEMING,

23 Liberty St., New York.

IMPORTER OF

"BRIDGEND" "DINAS"

Silica FIRE Bricks

FOR COKE OVENS AND GAS WORKS.

PORTLAND AND ROMAN CEMENTS.
Correspondence Invited. Lowest Prices.

DURING THE PAST YEAR, THE

NATIONAL GAS LIGHT AND FUEL CO.

218 LA SALLE ST., CHICAGO,

Have Erected Twelve Sets of Water Gas Generating Apparatus under the Springer Cupola System. They are as follows:

Newton Illuminating Company, Newton, Kansas.—Daily capacity, 120,000 cu. ft.

Wellington Light & Heat Co., Wellington, Kansas.—Daily capacity, 120,000 cu. ft.

Chippewa Falls, Gas Light Co., Chippewa Falls, Wis.—Daily capacity, 120,000 cu. ft.

Elkhart Gas Light & Coke Co., Elkhart, Indiana.—Daily capacity, 120,000 cu. ft.

Madison City Gas Light Company, Madison, Wis.—Daily capacity, 120,000 cu. ft.

South Bend Gas Light Co., South Bend, Indiana.—Daily capacity, 250,000 cu. ft.

Sheboygan National Gas Comp'y, Sheboygan, Wis.—Daily capacity, 120,000 cu. ft.

Salina Gas Light Company, Salina, Kansas.—Daily capacity, 120,000 cu. ft.

Rathbun Company, Deseronto, Province Ontario.—Daily capacity, 80,000 cu. ft.

Jefferson City Gas Light Co., Jefferson City, Mo.—Daily capacity, 120,000 cu. ft.

Mankato Gas Light Company, Mankato, Minnesota.—Daily capacity, 80,000 cu. ft.

Minneapolis Gas Lt. & Coke Co., Minneapolis, Minn.—Daily capacity, 1,000,000 cu. ft.

1886

1886

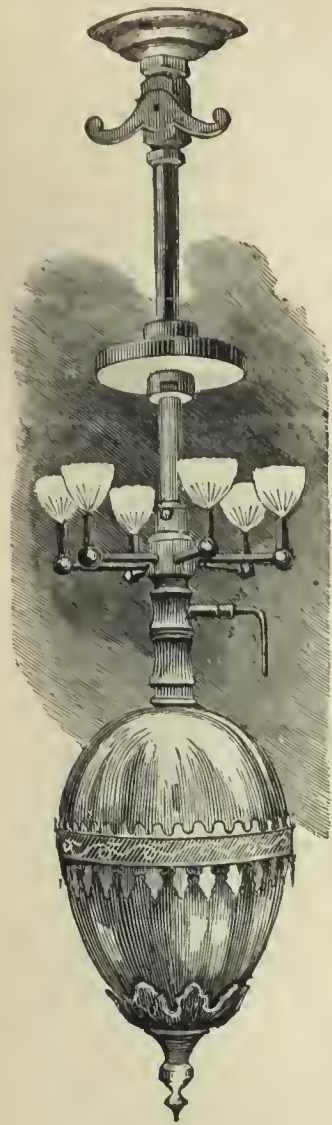

THE ALBO-CARBON LIGHT.

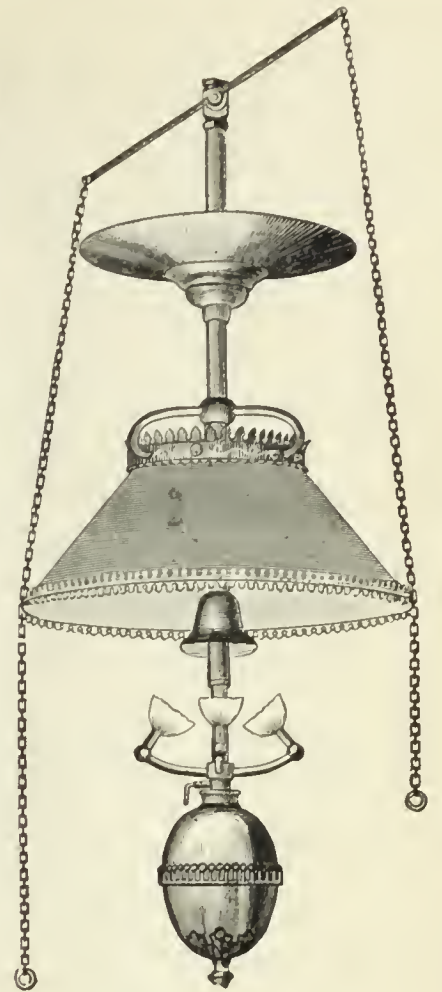

This most successful of all methods of enriching gas is based on the use of heated gas to vaporize a solid hydrocarbon, thus

COMBINING THE ADVANTAGES OF PREHEATING AND CARBURETTING.

The incoming gas passes over an extended heating surface (heated by means of the illuminating flames), and is raised to the temperature necessary to vaporize the carburetting material, which is a white, crystalline solid prepared from coal tar.

INJUNCTION GRANTED!

In the suit between this Company as complainant and Newman A. Ransom and the Chicago Gas Apparatus Manufacturing Company as defendants, pending in the Circuit Court of the United States for the Northern District of Illinois, on a late hearing of said cause before his Honor, Judge Gresham, Judge of said Court, an order was made and entered therein, a copy of which is hereto annexed, supporting our charge of infringement of our Letters Patent No. 247,925, dated Oct. 4, 1881, and of our Letters Patent No. 333,862, dated Jan. 5, 1886, and sustaining our rights under said several Letters Patent, to which especial attention is hereby directed, viz.:

UNITED STATES CIRCUIT COURT,
Northern District of Illinois.

WALTER J. KIDD

vs.

CHICAGO GAS APPARATUS MANUFACTURING
COMPANY AND NEWMAN A. RANSOM.

In Equity.

The Bill of Complaint and the affidavits filed by the respective parties having been read and the arguments of the counsel for the respective parties having been heard and duly considered by the Court—C. K. Offield, Esq., of Offield, Towle & Phelps, for the Complainant, and John H. Whipple, Esq., of Merriam & Whipple, for the defendants—and it appearing that Letters Patent of the United States were issued in due form of law to Joshua Kidd, No. 247,925, dated October 4, 1881, for an Improvement in Apparatus for Enriching Gas, also Letters Patent of the United States to said Joshua Kidd No. 333,862, dated January 5, 1886, for an Improvement in Carburetting Attachments for Gas Fixtures, and that the title to said Letters Patent vests by mesne assignments in the complainant herein; and it appearing by the answer of the defendant corporation, the Chicago Gas Apparatus Manufacturing Company, that they have never

manufactured, used, or sold, or had anything whatever to do with any so-called apparatus for enriching gas of any kind or description whatever, or any carburetting attachment for gas fixtures of any kind or description whatsoever; and it appearing that said defendant, Newman A. Ransom, has infringed the second claim of said Letters Patent No. 247,925, dated October 4, 1881, and the first and second claims of said Letters Patent No. 333,862, dated January 5, 1886, by manufacturing and selling carburetting attachments for gas fixtures manufactured according to said Letters Patent contrary to the form of the statute in such case made and provided;

Now, therefore, it is hereby ordered, adjudged, and decreed, this 30th day of December, A. D. 1886, that an injunction be issued pursuant to the prayer of the Bill herein, strictly commanding and enjoining the said defendant, Newman A. Ransom, his clerks, attorneys, agents, servants, and workmen that they forthwith, and until the further order, judgment, and decree of this Court, desist from the making, using, or selling of any carburetting attachments for gas fixtures substantially as described and claimed in said Letters Patent in said above identified claims thereof; and that the complainant enter into Bond to be approved by the Clerk of said Court in the penal sum of two thousand dollars (\$2,000), to said defendant, Newman A. Ransom, conditioned to pay the defendant or his legal representative all such costs and damages as shall be awarded against the complainant in case the said injunction shall be dissolved, said Bond to be filed on or before the 22d day of January, 1887.

and our suit against W. S. Horry (trading as the Crystal Carbon Light Co.), Arthur Kitson (trading as Kitson & Co.), and others, defendants, for infringement of our Letters Patent above mentioned and referred to, pending in the Circuit Court of the United States for the Eastern District of Pennsylvania, has not yet been reached for hearing.

THE ALBO-CARBON LIGHT COMPANY, - - - NEWARK, N. J.,
Sole Manufacturers for the United States.

GAS ENGINES.

GAS ENGINES.

BOOKS.

THE CLERK GAS ENGINE CO.,

Main Office, 1012, 1014, 1016, 1018 Filbert St., Philadelphia, Pa.

WM. W. GOODWIN, Prest.

E. STEIN, Sec.

S. LEWIS JONES, Asst. Sec.

A. J. DOTY, Supt.

The utility and convenience of the Gas Engine being no longer an open question, it only remains now for intending purchasers to select the BEST. We claim for the CLERK GAS ENGINE that it is equal to any other manufactured as regards steadiness in running, simplicity, and ease of keeping in repair, and that it gives the greatest amount of power for the least money (both in first cost and expense of running) of any engine made. In support of this claim we refer to the test of the Gas Engines made under the direction of the American Institute of New York, in December, 1885, and heretofore published in these columns. These engines are especially adapted for continuous running under heavy loads, and we can refer to Engines which have run 22 hours a day for months at a time.

Made in Sizes of 5, 10, 15, 20, and 25 Horse Power. All Engines Guaranteed for One Year.

THE CRYSTAL CARBON LIGHT!

The Latest and Most Improved Gas Light!

ADAPTED FOR PRIVATE RESIDENCES, CHURCHES, THEATERS, STORES, ETC.

These Burners are manufactured on the principle of enriching gas by means of Naphthaline (so-called Crystal Carbon or Albo-Carbon), the invention of the Rev. W. R. Bowditch, F.R.S., of Wakefield, England, who was the original inventor and patentee of this system of gas lighting.

SPECIAL NOTICE.

Many Gas Companies find the Crystal Carbon Light a valuable competitor against the Electric Light. It is ornamental, free from the defects common to all other enriching gas burners, and is as cheap as ordinary gas chandeliers. We sell direct to gas companies, giving them the benefit of agents' discounts.

CARBONCRYSTAL.

(Trade Mark.)

A new and superior preparation for enriching gas used in conjunction with Crystal Carbon or Albo-Carbon gas lights. The preparation is cleaner and better adapted for filling burner vessels than any hitherto produced. Guaranteed to be chemically pure. Supplied in cans from 10 pounds up.

THIS IS THE CHEAPEST AND PUREST FORM OF ENRICHING MATERIAL.

CRYSTAL CARBON LIGHT CO.,
Main Office, No. 1018 Chestnut Street, Philadelphia, Pa.

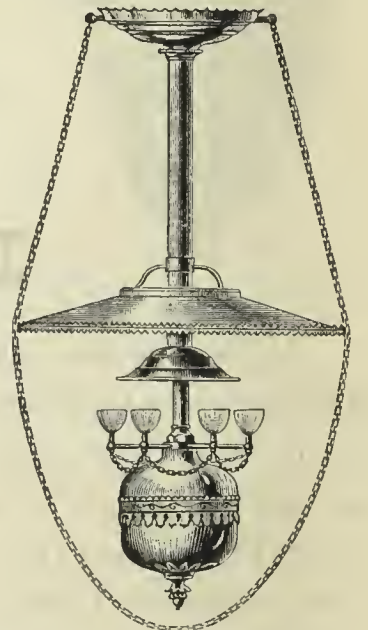

GAS

AS A SOURCE OF

LIGHT, HEAT, AND POWER.

By C. J. R. HUMPHREYS.

A Pamphlet of twenty-nine pages, treating of the use of Gas as a source of Light, Heat, and Power.

DESIGNED FOR DISTRIBUTION BY GAS COMPANIES AMONG THEIR CUSTOMERS AND OTHERS.

Price, 10 cents each, \$5 per 100, \$50 per 1,000.

Gas Companies can have their own imprint placed on cover without extra charge. All orders to be sent to

A. M. CALLENDER & CO.,

No. 42 Pine Street, N. Y. City.

CONNELLY'S AUTOMATIC GOVERNOR FOR STREET MAINS.

We invite the attention of all practical Gas Managers to the following letter and accompanying cut. The two lines show the pressure held by the Governor on Saturday and Sunday, and clearly illustrates the accuracy of the Governor in *increasing* and *reducing* pressure *in proportion to the volume of gas consumed*.

A Governor that puts the increased pressure on at "one fell swoop" and takes it off in like manner is *not* an "Automatic" Governor; and the circulation of pressure sheets showing such action by a so-called "Automatic" Governor is a rather amusing reflection on the intelligence of Gas Managers.

Strictly speaking, a "Balanced" Governor is an "Automatic" one, as it automatically varies the volume of gas sent out to *maintain a uniform pressure* at its outlet. But, as now applied, the term "Automatic Governor" is understood to mean a Governor that will *maintain pressure between any two desired extremes, in direct proportion to the volume of gas consumed*. Therefore pressure sheets showing *instantaneous changes* from maximum to minimum and *vice versa*, circulated broadcast as the record of an "Automatic (?) Governor," reveals inexcusable ignorance of the subject, amusing to many, yet liable to mislead the inexperienced novice.

We would suggest that all Gas Companies contemplating the placing of *Automatic* Governors would consult their own interests and avoid annoying experience by adopting a Governor *that has a record*.

CONNELLY & CO., LTD., 177 Broadway, N. Y.

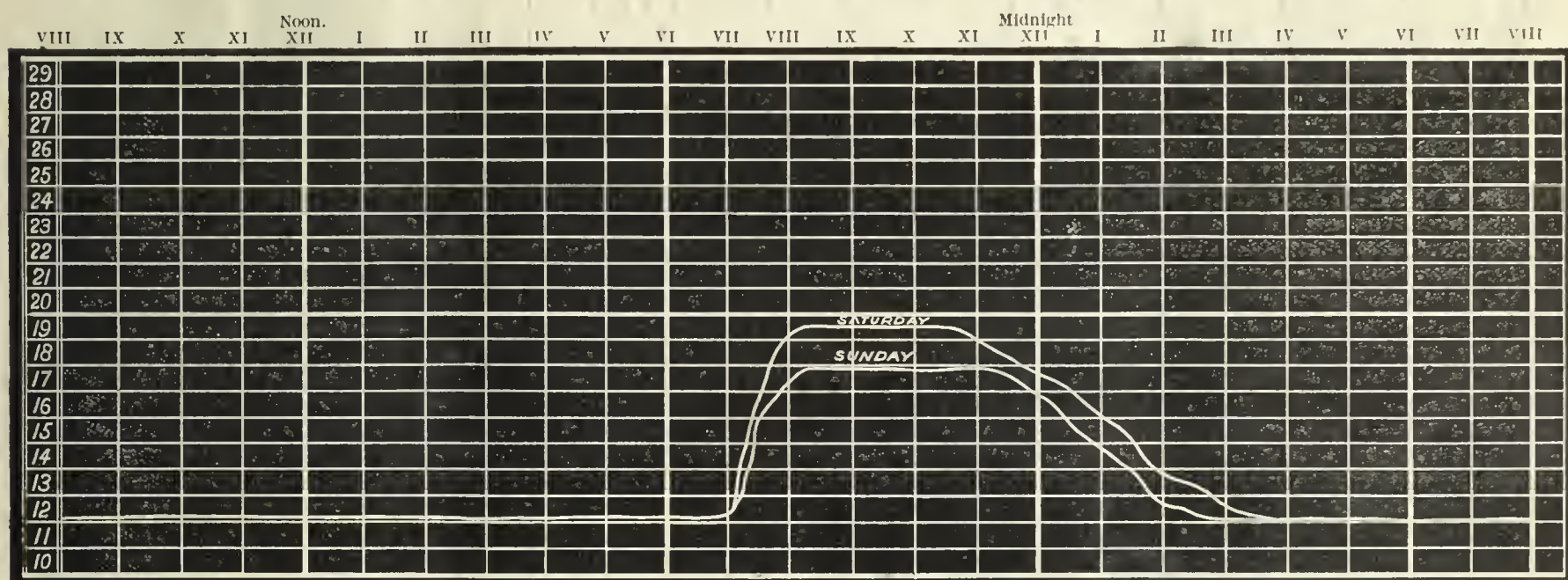

Card Showing Pressure at the Milwaukee Gas Works, Saturday, July 10, and Sunday, July 11 1886.

MILWAUKEE, Wis., August 3d, 1886.

MESSRS. CONNELLY & Co., LTD., 177 Broadway, New York:

Gentlemen—Replying to yours of 29th, I send you a little package of register sheets. When your Governor (20-inch) was set I adjusted it to give 13-tenths day pressure and 22-tenths night pressure. Saturday nights it would run up to 25-tenths. Whenever it would cloud up in the daytime it would go up at first indication of darkness to about 15-tenths. I hunted back in the sheets to find one when pressure was increased in the daytime, but it is so long since we have had a stormy day I could not find one. You can, however, see a *slight change* on sheets for June 1 and June 25. You will see, too, that lately the Governor only puts on *about 20-tenths maximum pressure*. This is because *less gas is burned than when it was adjusted*. We have no complaints of pressure, and everyone appears satisfied. In conclusion, can say the Governor has *never been touched* since it was first adjusted, and has at all times *done just the work we wished it to do*. Very truly yours, E. G COWDERY, Engr. & Supt.

T. C. HOPPER'S

AUTOMATIC DIFFERENTIAL GAS GOVERNOR

Is now in Practical Operation, doing Perfect Automatic Service with Great Precision.

This Governor will do all and more than any other Governor on the Market.

BE SURE TO THOROUGHLY INVESTIGATE THE SUPERIOR MERITS OF THIS GOVERNOR BEFORE PURCHASING.

For Simplicity and Reliable Work it has no Equal. Correspondence Solicited.

T. C. HOPPER & CO., - - Manufactory, 2227 Wood Street, Phila, Pa.

G. S. COOK, Pres. THOS. DAVENPORT (late Davenport Bros.), Sec. & Treas

BARTLETT Street Lamp Mfg. Co.

MANUFACTURERS OF

Bartlett's Patent

GLOBE LAMPS.

FOR

Streets, Parks, Railroad Stations, Public Buildings, Etc.

LAMP POSTS A SPECIALTY.

Office and Salesroom

No. 35 Howard Street, N. Y. City.

Gas Companies and others intending to erect lamps and posts will do well to communicate with us.

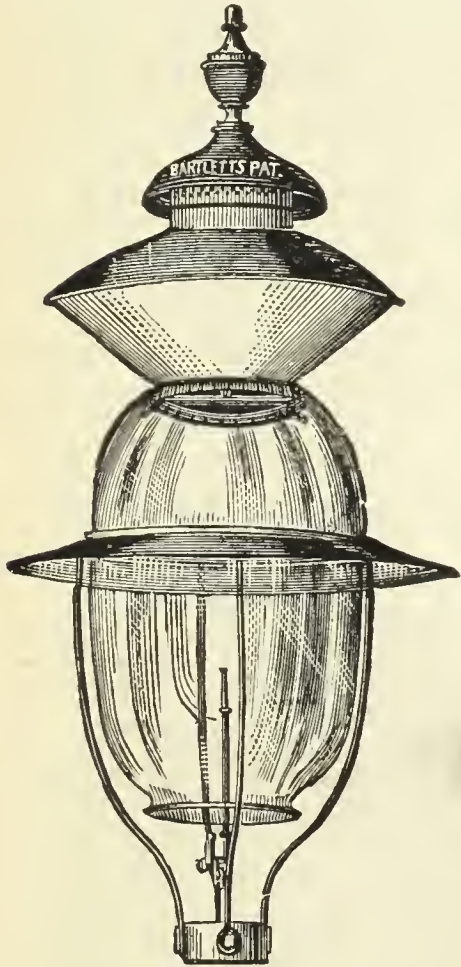

CONNELLY & CO., LTD.

MANUFACTURERS OF

Steam-Jet Exhausters

Requires one-half the floor space and one-third less steam than any other Exhauster in the market. More cheaply and easily connected, as outside by-pass valves are dispensed with. It is the only Exhauster manufactured having Compensator and Governor combined; the Compensator with all other Exhausters being a separate and distinct machine. It is simple in construction, easily adjusted, not liable to get out of order, and can be operated by ordinary workmen. Over 1,000 now in use.

No. 177 Broadway, New York.

LUDLOW VALVE MFG. CO.



OFFICE AND WORKS,

938 to 954 River Street and 67 to 83 Vail Av. TROY, N. Y.

Hydraulic Main Dip Regulators, also Check Valves, Foot Valves, Yard-wash and Fire Hydrants. Send for Circulars.

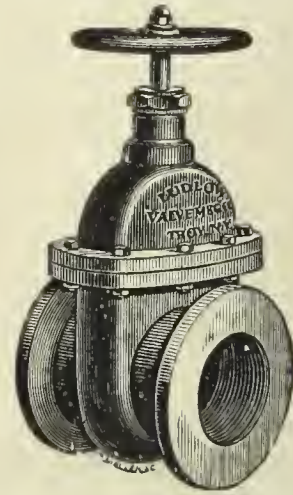

Valves.—Double and Single Gate, 1/2 in. to 48 in., outside and inside Screws. Indicator, etc., for Gas, Water, Steam, and Oil. Send for Circulars.

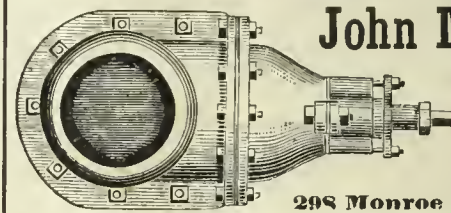

John McLean

Manufacturer of

GAS VALVES.

298 Monroe Street, N. Y.

F. M. ROOTS.

S. C. ROOTS

D. T. ROOTS.

P. H. & F. M. ROOTS PATENTEES AND MANUFACTURERS OF

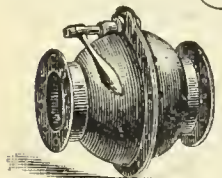

GAS VALVE.

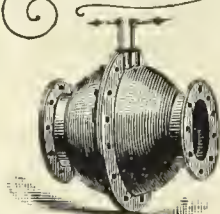
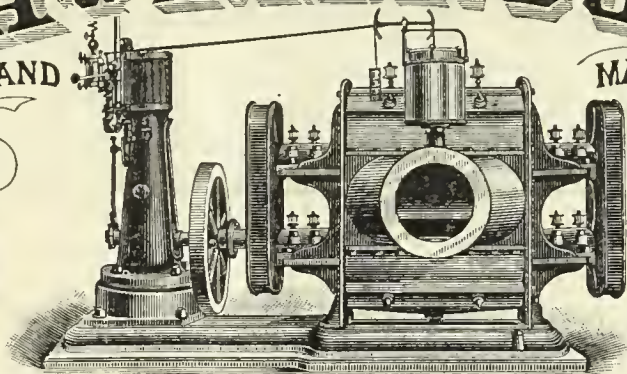

BYE-PASS.

IMPROVED GAS EXHAUSTER,

WITH ENGINE ON SAME BED PLATE, OR WITHOUT.

BYE-PASSES, GAS VALVES, GOVERNORS, ELBOWS, PIPE-FITTINGS, Etc., FURNISHED TO ORDER,

P. H. & F. M. ROOTS, Patentees & Manufacturers, CONNERSVILLE, IND.

S. S. TOWNSEND, General Agent, 22 Cortland St.

COOKE & CO., Selling Agents, 22 Cortland St., N. Y.

SEND FOR ILLUSTRATED CATALOGUE AND PRICE LIST.

GAS vs. ELECTRIC LIGHT.

We would invite attention to the able and exhaustive argument of General A. Hickenlooper, President of the Cincinnati Gas Light and Coke Company, contained in a handsome pamphlet of 96 pages, entitled

"EDISON'S INCANDESCENT ELECTRIC LIGHTS FOR STREET ILLUMINATION. REPORT OF AN ARGUMENT DELIVERED BY A. HICKENLOOPER BEFORE THE COMMITTEE ON LIGHT, MUNICIPAL COUNCIL, CITY OF CINCINNATI, JULY 22, 1886."

This is a subject of special interest to all Gas Light Companies.

Prices.

25 copies.....	\$7.50	100 copies.....	\$22.50
50 copies.....	12.50	250 copies.....	50.00

A sample copy will be sent by mail on receipt of 50 cts.

A. M. CALLENDER, & CO., 42 PINE ST., N. Y. CITY.

C. W. HUNT CO.,

No. 111 Broadway, N. Y. City.

MANUFACTURERS OF

Coal Handling Machinery,

AUTOMATIC RAILWAY, HOISTING ELEVATOR, CABLE RAILWAY, STEAM SHOVEL, HOISTING ENGINES, COAL TUBS, COAL & COKE CARS.

Plans and Specifications made for the

Erection of Coal Storage Buildings

Send for a Descriptive Pamphlet.

GAS STOVES.

GAS STOVES.

GAS STOVES.

THE AMERICAN METER CO.,

MANUFACTORIES,

508 to 514 West Twenty-second St., N. Y.

Arch and Twenty-second St., Phila.

Nos. 244 & 246 North Wells Street, Chicago, Ill.

AGENCIES,

No. 177 Elm Street, Cincinnati, Ohio.

Nos. 122 & 124 Sutter Street, San Francisco Cal.

No. 810 North Second Street, St. Louis, Mo.

NEW

INCANDESCENT

Gas Fires

AND

OPEN

Fire Place

Heaters.

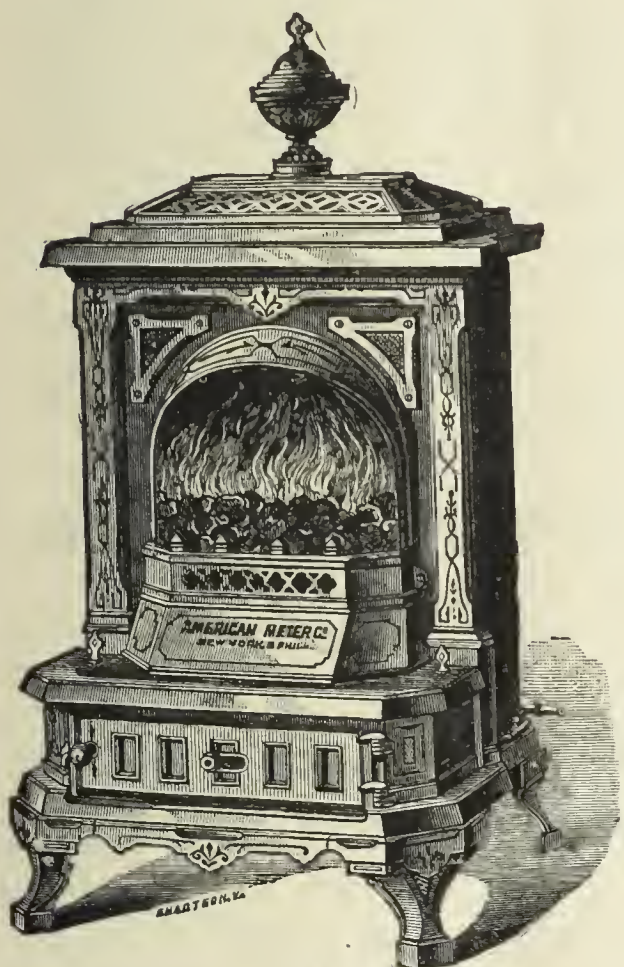

Open Fire Place Heater No. 19.
Fitted with the new Incandescent Gas Fire.

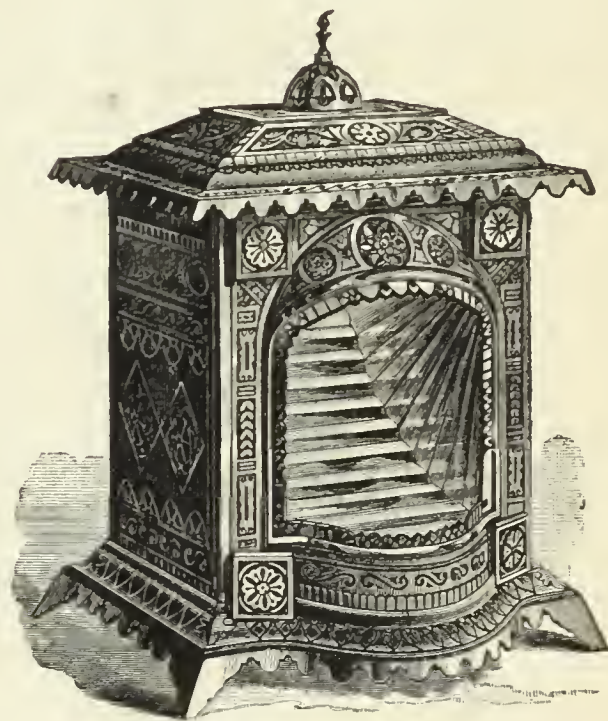

Open Fire Place Heater No. 17C.
Fitted with Illuminating Burners and Copper Reflectors.

We call attention to Special Apparatus Heated by Gas for Manufacturing Purposes.

GAS FURNACES FOR TINMEN'S USE; FURNACES FOR MELTING SOLDER AND TYPE METAL; APPARATUS FOR BENDING CARRIAGE PANELS, NOW IN SUCCESSFUL OPERATION IN CARRIAGE MANUFACTORIES; WATER HEATERS FOR KITCHEN BOILERS, BATHS, ETC., AND FOR ATTACHING TO HEATING COILS AND PIPES FOR CONSERVATORIES.

THE COMPANY MANUFACTURE

GAS STOVES FOR COOKING AND HEATING PURPOSES

In all Sizes, for Domestic, Restaurant, and Hotel Use.

These Stoves may be seen in operation at our Retail Store, No. 223 Sixth Avenue, N. Y. Call and examine.

SEND FOR CATALOGUE OF TWENTY DIFFERENT STYLES OF HEATING STOVES.

RETORTS AND FIRE BRICK.

J. H. CAUTIER & CO.,

CORNER OF

GREENE AND ESSEX STREETS,
JERSEY CITY, N. J.

MANUFACTURERS OF

Clay Gas Retorts,
Gas House Tiles,
Fire Bricks, Etc. Etc.Ground Clay, Fire Brick and
Fire Sand in Barrels,J. H. GAUTIER.
C. E. GREGORY.T. B. GAUTIER.
C. E. GAUTIER.**BROOKLYN**Clay Retort & Fire Brick Works,
(EDWARD D. WHITE & CO.)Manufacturers of Clay Retorts, Fire Brick,
Gas House and other Tile.VAN DYKE, ELIZABETH, RICHARDS & PARTITION STS.
Office, 88 Van Dyke St., Brooklyn, N. Y.

RETORTS AND FIRE BRICK.

LACLEDE FIRE BRICK MFG. CO.,

MANUFACTURERS OF

Fire Brick, Gas Retorts,

AND

ST. LOUIS STANDARD SEWER PIPE.

Blast Furnace and Cupola Linings, every description of Fire
Clay Material, Fire Clay Flue Linings, Chimney Tops
Dry Milled and Crude Fire Clays, etc.

OFFICE AND DEPOT

901, 903, and 905 Pine Street,
ST. LOUIS, MO.

ESTABLISHED IN 1845.

B. KREISCHER & SONS,

OFFICE FOOT OF HOUSTON ST., E.R., N. Y.

Gas Retorts,**TILES, FIRE BRICK.**

AND EVERYTHING IN THE FIRE CLAY LINE.

RETORTS AND FIRE BRICK.

MANHATTAN

FIRE BRICK & ENAMELLED CLAY

RETORT WORKS.**ADAM WEBER.**

CLAY GAS RETORTS

AND RETORT SETTINGS

FIRE BRICKS, TILES, ETC.,

Office and Works, 15th Street and Avenue C., N. Y.

Works,
LOCKPORT STATION, PA.

—ESTABLISHED 1864.—

JAMES GARDNER, JR.,

Successor to WILLIAM GARDNER & SON.

Fire Clay Goods for Gas Works.

CHAS. H. SPRAGUE & SON, No. 70 KILBY STREET, BOSTON, MASS., Agents for the New England States.

Office, Rooms 19 & 20, Lewis Block,
PITTSBURGH, PA, P. O. Box 373.

OFFICE, 418 to 422 East 23d St., New York.

ESTABLISHED 1856.

WORKS, PERTH AMBOY, NEW JERSEY.

HENRY MAURER & SON,
Excelsior Fire Brick & Clay Retort Works
CLAY GAS RETORTS, BENCH SETTINGS, FIRE BRICK, TILES, ETC.**CHICAGO**

Retort & Fire Brick Works,

OFFICE AND FACTORY,
Clark, Forty-Fifth, and La Salle Streets,
CHICAGO, ILL.

GEORGE C. HICKS, PRES. PAUL P. USTIN, SEC. & TREAS.

STANDARD

Clay Retorts and Settings.

BLOCKS & TILES

Of every Shape and Size to Order.

Standard Fire Bricks.

NEWBIGGING'S**Gas Manager's Handbook.**

Price, \$4.80.

EVERY GAS MAN SHOULD HAVE ONE.

Orders may be sent to this Office.

OAKHILL**GAS RETORT & FIRE BRICK**

Works.

Proprietors,

PARKER-RUSSELL MINING & MFG. CO.

City Office, 711 Pine Street,

ST. LOUIS, MO.

Our immense establishment is now employed almost entirely in
the manufacture of

MATERIALS FOR GAS COMPANIES.

We have studied and perfected three important points. Our re-
torts are made to stand changes of temperature, the strongest
heats of the furnace, and the abrasion of feeding and emptying.
Our customers are in almost every State of the Union, to all of
whom we refer.

THOS. SMITH, Prest.

AUGUST LAMBLA, Vice-Prest. & Sup

BALTIMORE**RETORT & FIRE BRICK CO.**

MANUFACTORY AT

LOCUST POINT, BALTIMORE, MD.

Connection with the City by Telephone.

Clay Retorts, Blocks & Tiles,
FIRE BRICK, FIRE CLAY,
AND FIRE CEMENT.Red and Buff Ornamental Tiles and Chim-
ney Tops. Drain and Sewer Pipe (from
2 to 30 inches). Baker Oven Tiles
12x12x2 and 10x10x2.

WALDO BROS., 88 WATER ST., BOSTON, MASS

Sole Agents the New England States

RETORTS AND FIRE BRICK.

REGENERATIVE FURNACES.

STEAM PUMPS.

EVENS & HOWARD,

916 Market St., St. Louis. Mo.
Works, Howard Station, Mo. Pacific R.R.

Fire Brick, Gas Retorts

AND

RETORT SETTINGS.

Sewer Pipe, 3 to 24 in. diameter.
Glass Pot Clay, Ground Fire Clay, in barrels and in bulk. All kinds of Fire Clay Goods.

Cincinnati Gas Retort & Fire Brick Works.

—ESTABLISHED 1872.—

CHAS. TAYLOR,

MANUFACTURER OF

Gas Retorts, Fire Brick, and Tile.

Blast Furnace Linings, Cupola Blocks, Boiler Tiles, Grate Settings, and Stove Linings. Fire Cement, Fire Clay, Fire Sand, and all other Fire Clay Goods.

Branch Works, New Cumberland, W. Va.

GENERAL OFFICE AND WORKS,

Burns St., Cincinnati, Ohio.

Stettiner

Chamotte Fabrik Actien Gesellschaft,

Formerly **DIDIER,**

(Patentees of the Dr. Schilling & Dr. Bunte Regenerative Furnace)

STETTIN, GERMANY.

The attention of all Gas Engineers is called to our Fire-Proof Material, viz.:

CLAY GAS RETORTS

(ENAMELED AND UNENAMELED),

Blocks, Tiles

AND

EXTRA FIRE BRICK,

Pronounced by the highest authorities as superior to and excelling any other similar manufacture. The component of aluminum contained in our material (up to 45 per cent.) is larger than in any other material heretofore sold in the United States; whilst the uniformity of the goods is assured by the most scrupulous analysis of the clay used.

For any further information and prices please apply to

EMIL LENZ,

2 & 4 Stone St., Room 19, N.Y. City.

PATENTS.

FRANKLIN H. HOUGH,

Solicitor of American & Foreign Patents

925 F. ST., WASHINGTON, D. C.

(NEAR U. S. PATENT OFFICE.)

Personal attention given to the preparation and prosecution of applications for Letters Patent. All business before the U. S. Patent Office attended to for moderate fees. **No Agency in the United States possesses superior facilities for obtaining Patents,** or for ascertaining the patentability of inventions. Copies of patents furnished for 25 cents each. Correspondence solicited.

ADAM WEBER'S

New and Improved Regenerative Furnace.

ESPECIALLY ADAPTED FOR USE IN SMALL GAS WORKS.

A Saving of at Least Forty per Cent. over Old Methods.

Cheapness of construction and absence of elaboration are the chief characteristics of this Furnace. It is also applicable in cases where it is not convenient to excavate deeply below the line of the retort house.

Correspondence respectfully solicited. Descriptive Circulars on application.

Manhattan Fire Brick & Enameled Clay Retort Works.

OFFICE, 633 EAST FIFTEENTH STREET, N. Y. CITY.

MUNICH REGENERATIVE FURNACE

System Drs. Schilling and Bunte.

Greatest Durability! Minimum of Attention!

COMPLETE DISTILLATION IN 3½ HOURS.

Ten to Thirteen Pounds of Coke to Hundredweight of Coal.

NO CLINKER. NO CARBONIC OXIDE IN THE REGENERATIVE FLUES.

Almost Automatic in Action.

The Most Successful Regenerative Furnace in Use.

BARTLETT, HAYWARD & CO.

Agents for the United States.

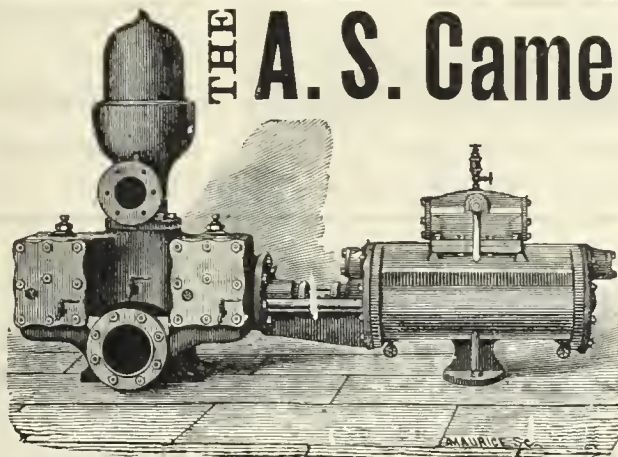

THE A. S. Cameron Steam Pump,

THE STANDARD OF EXCELLENCE.

Upward of 30,000 in Use.

BEST GAS WORKS PUMP

Ever Introduced.

Adapted to Every Possible Duty.

A. S. Cameron Steam Pump Works.

Foot East 23d St., N. Y.

Parson's Steam Blower,

FOR IMPROVING BAD DRAUGHT IN BOILERS, AND FOR BURNING BREEZE OR OTHER WASTE MATERIAL.

PARSON'S TAR BURNER,

FOR UTILIZING COAL TAR AS FUEL.

PARSON'S AIR JET TUBE CLEANER,

FOR CLEANING BOILER TUBES.

These devices are all first-class. They will be sent to any responsible party for trial. No sale unless satisfactory. Manufactured by the WATERTOWN STEAM BLOWER COMPANY.

H. E. PARSON, Supt., 42 PINE ST., N. Y.

GAS AND WATER PIPES.

GAS AND WATER PIPES.

ENGINEERS.

SAM'L R. SHIPLEY, Pres.
HENRY B. CHEW, Treas.JAS. P. MICHELLON, Sec.
WM. SEXTON, Supt.

GLOUCESTER IRON WORKS,

GLOUCESTER CITY, N. J.



Cast Iron Gas & Water Pipes, Stop Valves, Fire Hydrants, Gasholders, &c.

Office No. 6 North Seventh Street, Philadelphia.

ESTABLISHED 1856.

WARREN FOUNDRY AND MACHINE CO.,

WORKS AT PHILLIPSBURGH, N. J.
NEW YORK OFFICE, 162 BROADWAY.

Cast Iron Water and Gas Pipe

FROM TWO TO FORTY-EIGHT INCHES DIAMETER.
ALSO ALL SIZES OF

FLANGE PIPE for Sugar House and Mine Work.
Branches, Bends, Retorts, Etc., Etc.

436-1

MATHEW ADDY, President.

W. L. DAVIS, Selling Agent.

GEO. P. WILSHIRE, Sec. & Treas.

Cincinnati and Newport Iron and Pipe Company,

NEWPORT, KY.

Lamp Posts

AND

BENCH CASTINGS

A Specialty.

Large & Heavy Castings for General Work.
Manufacture Pipe from 2 to 48 inches. All work guaranteed first quality.

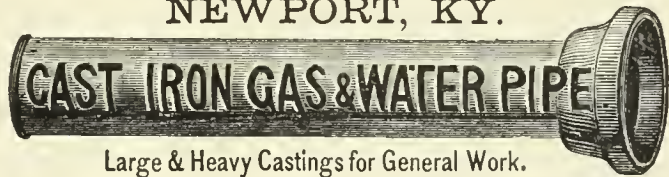

Branch

AND

SPECIAL CASTINGS

FOR GAS & WATER CO'S.

Pancoast & Rogers.

WROUGHT IRON PIPE,

VALVES AND GATES,

Cast Iron Gas & Water Pipe.

28 Platt and 15 Gold St., New York.

The Management of Small Gas Works.

By C. J. R. HUMPHREYS. Price, \$1.

A. M. CALLENDER & CO., 42 Pine St., N. Y.

P. D. WANNER, Chairman. A. H. MELLERT, Sec. & Treas.

MELLERT FOUNDRY & MACHINE CO., Ltd.

Reading, Pa.



Specials—Flange Pipe, Valves and Hydrants,
Lamp Posts, Retorts, etc.

General Foundry and Machine Work.

JOHN FOX, Selling Agent. 160 Broadway, N. Y.

THE OHIO PIPE COMPANY,

MANUFACTURERS OF

Cast Iron Gas & Water Pipe,

BRANCH AND SPECIAL CASTINGS.

Gas-House Bench Castings, Hydraulics, Lamp Posts, Flange Pipe
and Specials, Architectural Castings, Building Columns,
Joists, Cellar Grates, Sash Weights, etc.

GENERAL FOUNDERS AND MACHINISTS.

Columbus, Ohio.

M. J. DRUMMOND,



SPECIAL CASTINGS AND LAMP POSTS.

95 Liberty St., - New York.

JOS. R. THOMAS, C.E.,

May be Consulted on all Mat-
ters Relating to Gas Works
and Gas Manufacture.

ADDRESS THIS OFFICE.

WM. FARMER, ENGINEER,

32 Park Place, Room 36, New York.

THE CHEMIST'S ASSISTANT; OR, KINDERGAR-
TEN SYSTEM OF CHEMISTRY.

A system by which the elements and their valences are repre-
sented by illustrations and solid bodies.

BOX AND PAMPHLET COMPLETE, \$2.50.

WM. HENRY WHITE,

CONSULTING AND CONSTRUCTING

Gas Engineer & Contractor

Estimates, Plans, and Specifications furnished for new wo-
extensions of existing works.

No. 32 Pine Street, New York City.

Correspondence solicited.

WM. GARDNER,

Gas Engineer,

Lewis Block, Room 20, Pittsburgh, Pa.

Those who intend to make alterations in existing gas plants, or
who contemplate the erection of new works, will find it to their
interest to open correspondence with the above. Plans made
and estimates furnished.

GAS LAMPS.

SCRUBBERS AND CONDENSERS.

The Siemens and Lungren REGENERATIVE GAS LAMPS.

A System of Burning Gas whereby its Illuminating Power is Increased from 300 to 400 per ct. without the Expense, Trouble and Annoyance resulting from the use of Hydrocarbon Enriching Material.

The Siemens-Lungren Company received the only Silver Medal or Highest Award for Gas Burners at the "Novelties" Exhibition of the Franklin Institute, held at Phila., Oct., '85.

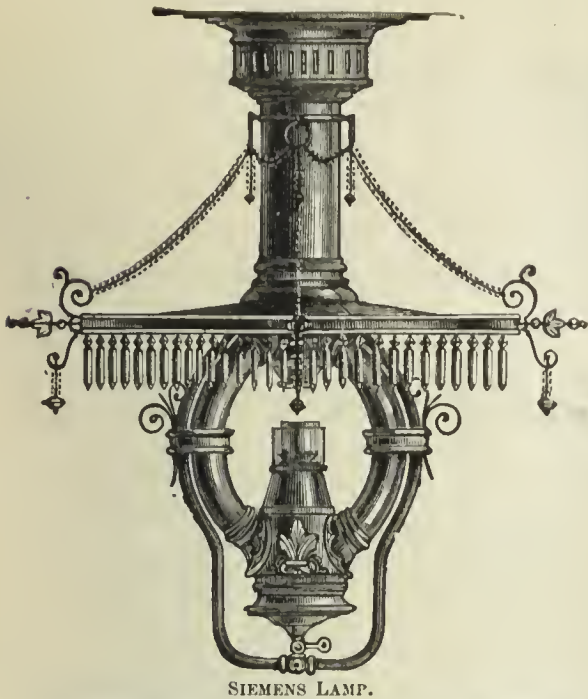

SIEMENS LAMP.

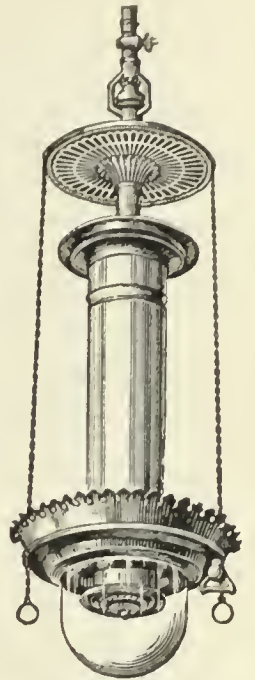

LUNGREN LAMP.

THIRTEEN CANDLE POWER PER CUBIC FOOT OF GAS!

This result is obtained

SIMPLY BY THE SCIENTIFIC APPLICATION OF THE REGENERATIVE PRINCIPLE.

Consequently this largely increased illumination is always maintained without further cost and frequent attention.

THE SIEMENS-LUNCREN COMPANY,

N. E. Cor. 21st. St. and Washington Av., Phila., Pa.

THE "STANDARD" WASHER-SCRUBBER.

The "Standard" Washer-Scrubber has been adopted very generally by Gas Companies in North and South America, Europe, Asia, Australia, and New Zealand.

NO OTHER APPARATUS REMOVES ALL THE AMMONIA FROM THE GAS.

Its dimensions admit of placing it under cover without the great expense incurred in a high building to protect Tower Scrubbers from changes of temperature; thus the "Standard" Washer-Scrubber costs much less than other systems.

J. B. Crockett, Esq., President and Engineer of the San Francisco Gas Light Company, writes, under date of May 22, 1886:

"The 'Standard' Scrubbers have been in constant operation for the past six months, and have given entire satisfaction. We have tried them under many different conditions, and find that, by the use of about two gallons of water per thousand feet of gas, it gives us Liquor of 15 oz. strength. Our coal is from British Columbia, and contains large quantities of Ammonia, and we found it impossible to remove all the Ammonia with one gallon of water; but with two gallons we get good, strong Liquor, and at the same time have no traces of Ammonia at the outlet."

Recent Orders for "Standard" Washer-Scrubbers have been received from

- J. P. HARBISON, ESQ., Treas. Hartford City Gas Light Company, and Prest. New England Association of Gas Engineers.
- L. N. VAN KEUREN, ESQ., Secretary Bridgeport Gas Light Company - - - - - Bridgeport, Conn.
- W. H. PEARSON, ESQ., Secretary and General Manager Consumers Gas Light Company, - - - - - Toronto, Can.
- E. M. BREESE, ESQ., Engineer and Superintendent Detroit Gas Light Company, - - - - - Detroit, Mich.

GEO. SHEPARD PAGE, No. 69 WALL STREET, NEW YORK,
SOLE AGENT FOR THE WESTERN HEMISPHERE.

GAS WORKS APPARATUS AND CONSTRUCTION.

GAS WORKS APPARATUS AND CONSTRUCTION.

WORKS: { MILLVILLE, N. J.
FLORENCE, "
CAMDEN, "

R. D. WOOD & CO.,

OFFICES: { 400 CHESTNUT ST.,
PHILADELPHIA.

CAST-IRON PIPE 1½ to 72 Inches in Diameter.

Water Machinery and Gas Apparatus.

HEAVY CASTINGS.

HOLDERS,

LAMP POSTS,

VALVES,

PURIFIERS,

CONDENSERS,

BENCH WORK,

METER CASES.

FLOORS AND ROOFS,

FLANGED PIPE,

FIRE HYDRANTS,

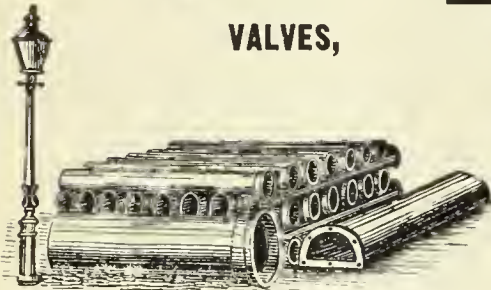

Estimates and Specifications for
NEW WORKS or **EXTENSIONS**
or **ALTERATIONS** of **OLD ONES.**

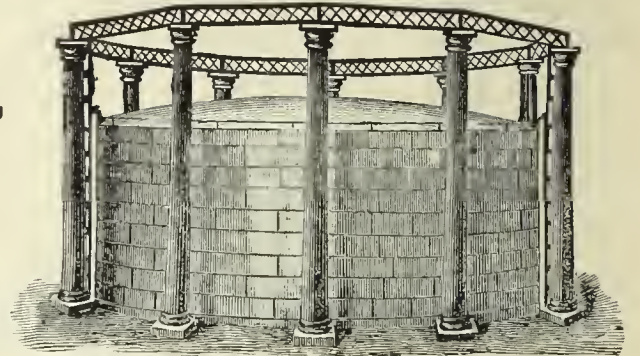

SMITH & SAYRE MFG. COMPANY,

G. G. PORTER, Prest.

245 Broadway, N. Y.

CHAS. W. ISBELL, Sec'y.

Machinery & Apparatus for Gas Works

Drawings, Plans, and Estimates Furnished for the Improvement, Extension, or Alteration of Gas Works, or for the Construction of New Works.

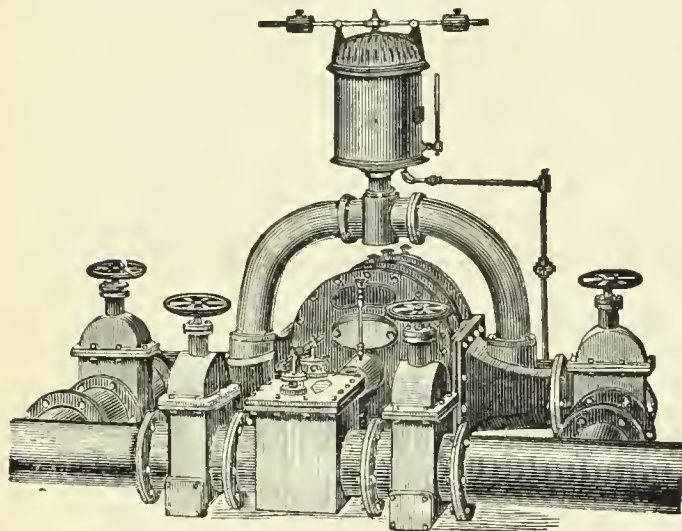

Mackenzie's Patent Rotary and Steam Jet Gas Exhausters, Governors, Compensators, Condensers, Washers, Scrubbers. Isbell's Patent Automatic Street Pressure Governor, Gas and Water Valves, Hydraulic Main Dip Regulator, Bench Castings, etc. Purifying Boxes and "Standard" Scrubbers. Isbell's Patent Self-Sealing Retort Doors.

SOUTHWARK FOUNDRY AND MACHINE COMPANY,

Successors to MERRICK & SONS,

GAS APPARATUS,

Holder, Purifiers, Washers, Etc., Etc. Boiler and Tank Work. Steam Engines. Hydraulic Machinery. Bessemer Plants, Etc.

Washington Ave. and Fifth Street, Philadelphia, Pa.

MORRIS, TASKER & CO.,

Limited,

Builders of Gas Works,

PHILADELPHIA PA.

GOODWIN'S DIRECTORY

OF THE

GAS LIGHT COMPANIES OF THE UNITED STATES & CANADA

Price, \$10.00.

Orders may be sent to

A. M. CALLENDER & CO., No. 42 Pine Street, N. Y. City.

GAS WORKS APPARATUS AND CONSTRUCTION.

GAS WORKS APPARATUS AND CONSTRUCTION.

JAMES R. FLOYD,

(SUCCESSOR TO HERRING & FLOYD)

Oregon Iron Works,

531 to 543 West 20th St., N. Y.

Practical Builders of Gas Works,

MANUFACTURERS OF

**ALL KINDS OF CASTINGS
AND
APPARATUS FOR GAS-WORKS.**

BENCH CASTINGS

from benches of one to six Retorts each.

**WASHERS: MULTITUBULAR AND
AIR CONDENSERS; CONDENSERS;
SCRUBBERS**

wet and dry), and

EXHAUSTERS

for relieving Retorts from pressure.

BENDS and BRANCHES

all sizes and description.

FLOYD'S PATENT

MALLEABLE RETORT LID.

PATENT

SELF-SEALING RETORT LIDS.

FARMER'S

PATENT BYE-PASS DIP-PIPE.

SABBATON'S PATENT

FURNACE DOOR AND FRAME.

BUTLER'S

COKE SCREENING SHOVELS.

GAS GOVERNORS,

and everything connected with well regulated Gas Works at low price, and in complete order.

SELLER'S CEMENT

for stopping leaks in Retorts.

N. B.—**STOP VALVES** from three to thirty inches—at very low prices.

Plans, Specifications, and Estimates furnished.

KERR MURRAY MFG. CO.,

MANUFACTURERS OF

Single Lift and Telescopic

GASHOLDERS.

Built, 1884:

Altoona, Pa.....	Capacity, 160,000 cubic feet.
Pittsburgh, Pa.....	250,000 "
" ".....	220,000 "
Bellaire, Ohio.....	50,000 "
Youngstown, Ohio.....	60,000 "
Canton, ".....	60,000 "
Akron, ".....	80,000 "
Xenia, ".....	10,000 "
Adrian, Mich.....	65,000 "
Ypsilanti, Mich... ..	25,000 "
Muskegon, ".....	70,000 "
South Bend, Ind.....	70,000 "
Anderson, ".....	20,000 "
Plainfield, ".....	10,000 "
Springfield, Illinois.....	100,000 "
Evanston, ".....	50,000 "
Freeport, ".....	35,000 "
Elgin, ".....	60,000 "
Sheboygan Wis.....	20,000 "
Key West Fla.....	10,000 "

Plans and estimates furnished for the erection of new and the rebuilding of old works. Address

**Kerr Murray Mfg. Co.,
FORT WAYNE, IND.**

CONTINENTAL WORKS.

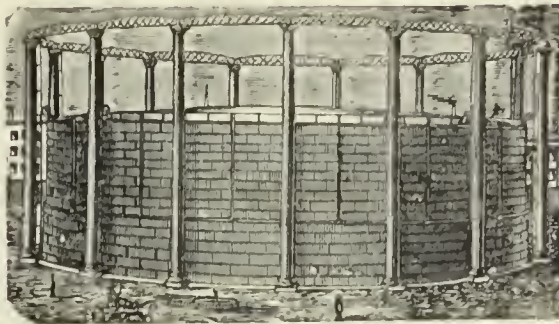

GASHOLDERS OF ANY MAGNITUDE.

T. F. ROWLAND, Proprietor,
GREENPOINT, BROOKLYN, N. Y.

ENGINEER AND MANUFACTURER OF

GAS-HOLDERS.

CONDENSERS, SCRUBBERS, VALVES,

PURIFIERS, RETORTS, and HY-

DRAULIC MAINS,

and all other articles connected with the Manufacture and Distribution of Gas. Plans and Specifications prepared and Proposals given for the necessary Plant for Lighting Cities, Towns, Mansions, and Manufactories.

H. RANSHAW, Prest. & Mangr.

WM. STACEY, Vice-Prest.

T. H. BIRCH, Asst. Mangr.

R. J. TARVIN, Sec. & Treas.

STACEY MFG. CO.,

MANUFACTURERS OF

Single and Telescopic Gasholders,

IRON ROOFS, BRIDGES, LAMP POSTS,

Water and Oil Tanks, Coal Elevator Cars,

COKE CRUSHERS, BENCH CASTINGS,

And all kinds of Wrought and Cast Iron Work used in the erection of Coal and Oil Gas Works. Rolling Mill Machinery and Heavy Castings a Specialty.

Foundry:

33, 35, 37 & 39 Mill Street.

Wrought Iron Works:

16, 18, 20, 22, 24 & 26 Ramsey Street:

Cincinnati, Ohio.

BARTLETT, HAYWARD & CO.,

Office, German & Calvert.

BALTIMORE, MD.

Works, Pratt & Scott.

PURIFIERS.
Roofs.
Bench Castings.

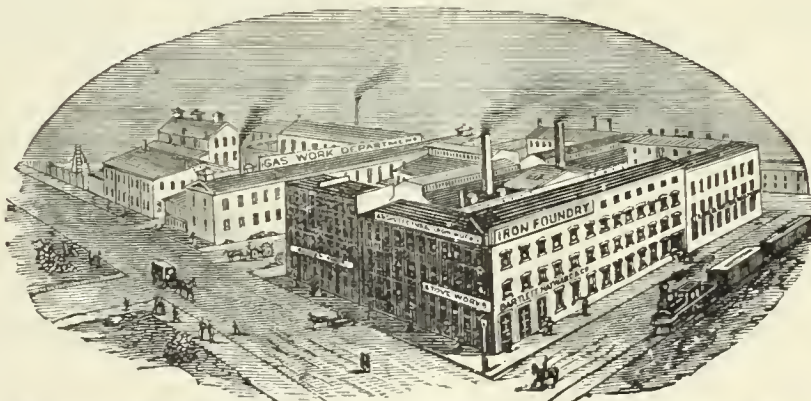

CONDENSERS
BOILERS.
SCRUBBERS.

GASHOLDERS.

CONSTRUCTING ENGINEERS AND BUILDERS OF GAS WORKS.

1842. DEILY & FOWLER, 1886.

Laurel Iron Works.

Address, No. 39 Laurel Street, Philadelphia, Pa.

MANUFACTURERS OF

GASHOLDERS,

Single or Telescopic, with Cast or Wrought Iron Guide Frames.

HOLDERS BUILT SINCE 1881:

Scranton, Pa. (2d)	Holidaysburg, Pa.	Jackson, Mich.	Montgomery, Ala.	New Castle, Pa.
West Point, N. Y.	Galveston, Texas (2d.)	Kalamazoo, Mich. (3d.)	Newport, R. I.	Long Island City, N. Y.
Fitchburgh, Mass.	Marlboro, Mass.	Glen Island, N. Y.	Portland, Oregon.	Macon, Ga.
New London, Conn.	Denver, Col.	Warren, Ohio.	Allegheny, Pa. (2d.)	York, Pa.
Derby, Conn.	Chicago, Ill. (West Side).	Bath, N. Y.	Atlanta, Ga. (2d.)	Chester, Pa.
Bridgeport, Conn.	Pittsburgh, Pa. (S. Side).	Lynn, Mass.	N.Y. City (Central Gas Co)	Hazleton, Pa. 2d.)
Allegheny, Pa. (1st.)	Pawtucket, R. I.	New Bedford, Mass.	Lynchburg, Va. (2d.)	Novelties Exhib., Phila
St. Hyacinth, Can.	Brookline, Mass.	Waterbury, Conn.	Saylesville, R. I.	Staten Island, N. Y.
Norwalk, O.	Sherbrooke, Can.	Deseronto, Can.	Rondout, N. Y.	Saugerties, N. Y.
Brattleboro, V	Burlington, N. J. (2d.)	Hoosic Falls, N. Y. (3d.)	Atlantic City, N. J.	Clinton, Mass. (Lan. MI
Waltham, Mass. (2d.)	Bridgeton, N. J.	Bethlehem, Pa.	Augusta, Ga.	Chattanooga, Tenn.
West Chester, Pa.	Bay City, Mich.	Atlanta, Ga. (1st.)	Waltham, Mass. (2d.)	Galveston, Texas. (3d.
Baltimore, Md.	Erie, Pa.	Savannah, Ga.	Mahanoy City, Pa.	Omaha, Neb.

GAS COALS.

GAS ENRICHERS.

EXHAUSTERS.

JAMES D. PERKINS.

PERKINS & CO.,

F. SEAVERNS.

General Sales Agents for

The Youghioghenny River Coal Company's**OCEAN MINE YOUGHIOGHENY GAS COAL.**

The Coal from the Ocean Mine (recently operated by Messrs. W. L. Scott & Co., of Erie, Pa.,) is now used by all the leading Gas Companies in the United States from Maine to Texas, and is recognized as *the only reliable Youghioghenny Gas Coal.* (See Map on p. 87 of this Journal, Feb. 16, 1885.)

P. O. Box 3695,
New York.**PERKINS & CO., 228 and 229 N. Y. Produce Exchange.**BEAVER STREET
ENTRANCE.**BRECKENRIDGE CANNEL,
OF KENTUCKY.**

This colliery was re-opened in June of the present year, and the Cannel is now being delivered to thirty of the leading Gas Companies in this country. As an enricher ONE TON of this Cannel will do the work of TWO TONS of any other available Cannel. It can be delivered in parcels of one car load or more to any point in the United States or Canada. (See AMERICAN GAS LIGHT JOURNAL, June 16, '86, pp. 346-7.)

P. O. Box 3695,
New York.**PERKINS & CO., 228 and 229 N. Y. Produce Exchange**BEAVER STREET
ENTRANCE.**JAMES & WILLIAM WOOD,
Gas and Cannel Coal Contractors,**

No. 40 St. Enoch Sq., Glasgow. No. 2 Talbot Court, London.

Proprietors of the **BATHVILLE COLLIERIES** (which produce the celebrated **BOGHEAD CANNEL**), Shields, Shieldmuir, Drumpeller, and other Collieries. This Firm offer

STANDARD CANNELS,**Unequaled as Gas Enrichers.**

Analyses, prices, and all further information furnished on application to

Agency for U. S., Room 93, Nos. 2 & 4 Stone St., N.Y. City.O. J. BENHAM,
President.C. M. HIGGINS,
Secretary.L. H. SEVERANCE,
Treasurer.**The Forest City Naptha Co.,**

REFINERS OF

Red Crown Brand**NAPTHA AND GASOLINES.**

ALSO MANUFACTURERS OF

**A Special Grade of Naptha for
Gas Companies****FOR ENRICHING COAL GAS.**

Correspondence solicited.

No. 43 Euclid Avenue, Cleveland, Ohio.

To Gas Companies.We make to order **CAP BURNERS** to burn any amount under a stated pressure. Send for samples.Also, **SERVICE CLEANERS, DRIP PUMPS, and STREET MAIN PROVING APPARATUS.****C. A. GEFROER,**

248 N. 5th Street, Phila., Pa.

The Wilbraham Gas Exhauster,**"BAKER SYSTEM,"**

WITH ENGINE ATTACHED, ON SAME BED PLATE OR WITHOUT.

Best, Cheapest and Most Durable Exhauster known.**WILBRAHAM BROS.,**

No. 2320 Frankford Avenue, Philadelphia, Pa.

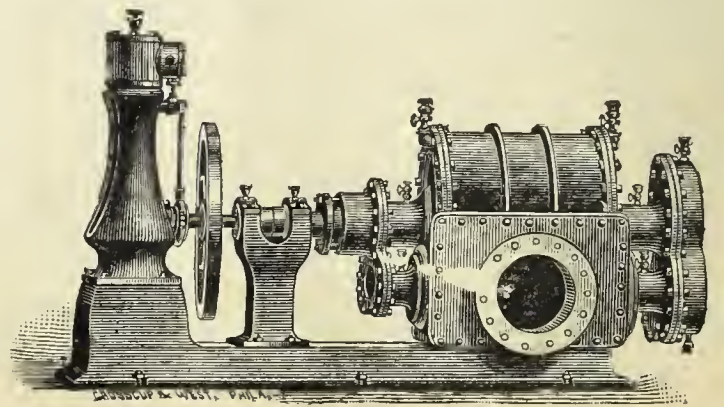

COKE CRUSHERS.

GAS COALS.

GAS COALS.

Newburgh Orrel Coal Co.,

MINERS AND SHIPPERS OF

Mountain Brook Steam and Smithing Coals,

AURORA, TYRCONNELL & PALATINE GAS COALS.

Foundry & Crushed Coke Shipped Direct from Ovens

Mines Situated at

Newburgh, Flemington & Fairmont, W.Va.

HOME OFFICE,

33 S. Gay St., Baltimore.

CHAS. MACKALL, Gen. Mangr.

CHAS. W. HAYS, Agent in New York,

Room 147, WASHINGTON BUILDING, No. 1 Broadway.

Shipping wharves at Locust Point, Baltimore.

THE DESPARD COAL COMPANY

OFFER THEIR SUPERIOR

DESPARD COAL

To Gas Light Companies and Manufacturers of Fire Clay Goods Throughout the Country.

ROUSSEL & HICKS, } AGENTS. { BANGS & HORTON, }
71 Broadway, N. Y. } 16 Kilby St., Boston.

Mines in Harrison Co., West Va. Wharves, Locust Point, Balt.

Company's Office, 15 German St., Baltimore, Md.

Among the consumers of Despard Coal we name: Manhattan Gas Light Co., N. Y.; Metropolitan Gas Light Co., N. Y.; Jersey City, (N. J.) Gas Light Co.; Washington (D. C.) Gas Light Co.; Portland (Maine) Gas Light Co. Reference to them is requested.

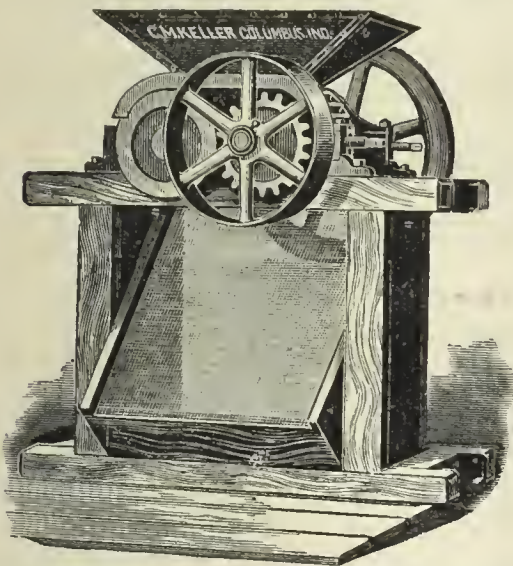

Keller's Adjustable Coke Crusher.

SIMPLE, STRONG, AND DURABLE.

C. M. Keller, Sec. & Supt. Gas Lt. & Coke Co. Columbus, Ind.

Correspondence Solicited.

GAS COMPANIES, ATTENTION!

Increase the demand for Coke by using the

Star Coke Breaker.

SIMPLE, CHEAP, DURABLE. EASILY SHARPENED BY ANY BLACKSMITH.

B. J. ALLEN, Newark Gas Co., Newark, N.J.

King's Treatise on Coal Gas.

The most complete work on Coal Gas ever published.

Three Vols. Bound, \$30.

A. M. CALLENDER & CO., 42 Pine St., N. Y.

THE PENN GAS COAL CO.

OFFER THEIR

Coal, Carefully Screened & Prepared for Gas Purposes.

Their Property is located in the Youghiogheny Coal Basin, near Irwin and Penn Stations on the Pennsylvania Railroad, and on the Youghiogheny River.

Principal Office:

209 SOUTH THIRD STREET, PHILA., PA.

Points of Shipment:

Pennsylvania Railroad Piers; Greenwich Wharves, Delaware River; Pier No. 1 (Lower Side), South Amboy, N. J.

Chesapeake & Ohio Railway Coal Agency,

FOR THE SALE OF THE

Superior Kanawha Gas Coals, Cannelton Cannel, Also, SPLINT AND STEAM COALS,

From the Kanawha and New River Regions, on the line of the Chesapeake & Ohio R'way.

C. B. ORCUTT, Sales Agent. | OFFICE, 150 BROADWAY, N. Y.

FRANCIS H. JACKSON, Prest. EDMUND H. MCCULLOUGH, V.-Prest. CHAS. F. GODSHALL, Treas. H. C. ADAMS, Sec.

THE WESTMORELAND COAL CO.

Chartered 1854.

Mines situated on the Pennsylvania and the Baltimore and Ohio Railroads, in Westmoreland County, Penn.

POINTS OF SHIPMENT:

PHILADELPHIA, BALTIMORE, SOUTH AMBOY, N. J., WATKINS (SENECA LAKE), N. Y.

Since the commencement of operations by this Company its well-known Coal has been largely used by the Gas Companies of New England and the Middle States, and its character is established as having no superior in gas giving qualities, and in freedom from sulphur and other impurities.

Principal Office, 224 South 3d St., Phila., Pa.

A. M. SCOTT, PRESIDENT. A. DEMPSTER, C.E., SECRETARY. W. K. GILLESPIE, TREASURER.

MONONGAHELA AND PETERS CREEK GAS COAL CO.,

PRODUCERS OF

Coal Bluff Gas Coal.

MINES LOCATED ON THE MONONGAHELA DIVISION OF THE PENNSYLVANIA RR., IN THE CENTRAL PORTION OF THE PITTSBURGH COAL FIELD.

Points of Shipment—Buffalo, Cleveland, Erie, Chicago, New Orleans.

Since the introduction of Coal Bluff Gas Coal it has taken rank among the few first-class Gas Coals, and acknowledges no superior in gas-giving qualities, ease of working, quality of coke, and freedom from impurities.

General Eastern Agents, ANDREW LANGDON & CO., Buffalo, N. Y.

General Western Agents, ANDREW LANGDON & CO., Chicago, Ill.

Milwaukee Agents, F. R. BUELL & CO., - - - Milwaukee, Wis.

General Office, 43 Sixth Ave., Pittsburgh, Pa.

GAS METERS.

GAS METERS.

GAS METERS.

INTERNATIONAL--1876--EXHIBITION.**The U. S. Centennial Commission**

HAVE DECREED AN AWARD TO

HARRIS, GRIFFIN & CO.,

Twelfth and Brown Streets, Philadelphia, Pa. No. 49 Dey Street, N. Y. City, and No. 75 North Clinton Street, Chicago, Ill.

FOR THE FOLLOWING REASONS :

The Exhibit consists of a Series of METERS from the Largest Size Station Meters for the use of the MANUFACTURE OF GAS, to those for the use of the ORDINARY CONSUMER. The Instruments are WELL MADE, RELIABLE as to INDICATION, and embody a number of sundry improvements which, with the general character of the Exhibit, entitle the whole to commendation.

Attest—J. L. CAMPBELL,
Secretary, pro-tem.

Signed—A. T. GOSHORN,
Director General

J. R. HAWLEY,
President

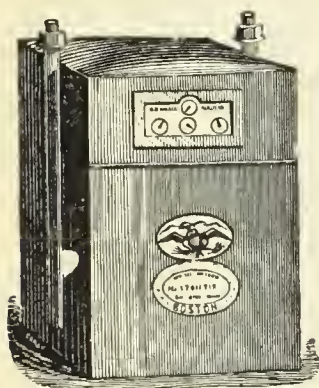

Dry Gas Meter.

NATHANIEL TUFTS,*No. 153 Franklin Street, Boston, Mass.,*

MANUFACTURER OF

DRY GAS METERS.

Station Meters of any Capacity.

Test and Experimental Meters, Pressure Registers, Pressure Gauges,
Pressure and Vacuum Gauges.**METER PROVERS, PHOTOMETERS, STREET LANTERNS, ETC., ETC.**

Patent Cluster Lanterns for Street Illumination.

With 39 years' experience and the best facilities for manufacturing, is enabled to furnish reliable work and answer orders promptly.

SCIENTIFIC BOOKS.

We are prepared to furnish to Gas Managers, and others interested in the topics treated of, the following books, at prices named :

KING'S TREATISE ON THE MANUFACTURE OF COAL GAS. Three vols.; \$10 per vol.	PRACTICAL TREATISE ON HEAT, by THOMAS BOX. Second edition. \$5.	THE GAS MANAGER IN THE LABORATORY, by a Practical Student. 8vo., Cloth. \$1.50.
GAS MANUFACTURE, by WILLIAM RICHARDS. 4to., with numerous Engravings and Plates, in Cloth binding. \$12.	GAS WORKS—THEIR ARRANGEMENT, CONSTRUCTION, PLANT, AND MACHINERY. \$8.	THE DOMESTIC USES OF COAL GAS, AS APPLIED TO LIGHTING, by W. SUGG. \$1.40.
THE GAS ANALYST'S MANUAL, by F. W. HARTLEY. \$2.50.	COAL; ITS HISTORY AND USE, by PROF. THORPE. \$3.50.	DISTILLATION OF COAL TAR AND AMMONIACAL LIQUOR by GEO. LUNGE. \$8.50.
TECHNICAL GAS ANALYSIS. \$2.80.	THE GAS WORKS OF LONDON, by COLBURN. 60 cents.	A TREATISE ON THE COMPARATIVE COMMERCIAL VALUES OF GAS COALS AND CANNELS, by D. A. GRAHAM 8vo., Cloth. \$3.
GAS MANAGER'S HANDBOOK, by THOS. NEWBIGGING. \$4.80.	THE GAS FITTER'S GUIDE, Showing the Principles and Practice of Lighting with Coal Gas, by JOHN ELDREDGE. 40 cents.	GAS AS A SOURCE OF LIGHT, HEAT, AND POWER, by C. J. R. HUMPHREYS. 10 cents.
GAS CONSUMER'S GUIDE. \$1.	GAS WORKS, AND MANUFACTURING COAL GAS, HUGHES. \$2.20.	GAS COMPANIES DIRECTORY. \$10.
A GUIDE TO GAS LIGHTING. 40 cents.	THE MANAGEMENT OF SMALL GAS WORKS, by C. J. R. HUMPHREYS. \$1.	GAS VERSUS ELECTRIC LIGHT. 50 cents.
GAS MEASUREMENT AND GAS METER TESTING, by F. W. HARTLEY. \$1.60	MANUAL FOR GAS ENGINEERING STUDENTS, by D. LEE, 40 cents.	PURIFICATION OF COAL GAS, by R. P. SPICE. 8vo. \$3.
GAS CONSUMER'S HANDBOOK, by WILLIAM RICHARDS, C.E.; 18mo., Sewed. 20 cents.	HOW TO MANAGE GAS, by F. WILKINS. Paper. 20 cents.	
A PRACTICAL TREATISE ON GAS AND VENTILATION with Special Relation to Illuminating, Heating, and Cooking by Gas, by E. E. PERKINS. \$1.25.		

The above will be forwarded by express, upon receipt of price. We take especial pains in securing and forwarding any other Works that may be desired, upon receipt of order. All remittances should be made by check draft, or post office money order.

A. M. CALLENDER & CO., No. 42 Pine Street, New York.**KING'S TREATISE ON COAL GAS.**

The most complete work on Coal Gas ever published. Three vols., bound \$30.

A. M. CALLENDER & CO., No. 42 Pine Street, New York.

GAS METERS.

GAS METERS.

GAS METERS.

T. C. HOPPER, Pres. G. J. McGOURKEY, Vice-Pres. (New York). WM. N. MILSTED, Gen. Supt. & Treas. (New York). WM. H. DOWN Sec.

AMERICAN METER COMPANY,

WET AND DRY GAS METERS.

PRESSURE REGISTERS.

METER PROVERS.

STATION METERS.

PRESSURE & VACUUM REGISTERS.

PORTABLE TEST METERS.

EXHAUSTER GOVERNORS.

PRESSURE & VACUUM GAUGES.

EXPERIMENTAL METERS.

DRY CENTRE VALVES.

CRESSON GAS REGULATORS.

AMMONIA TEST METERS.

GOVERNORS FOR GAS WORKS.

MARSLAND WATER METERS.

BAR AND JET PHOTOMETERS.

Manufactories:

512 W. 22d St., N. Y.
Arch & 22d Sts., Phila.

GAS STOVES,

SUGG'S "STANDARD" ARGAND BURNERS,
SUGG'S ILLUMINATING POWER METER,
Wet Meters, with Lizar's "Invariable Measuring" Drum.

Agencies:

177 Elm Street, Cincinnati.
214 & 216 N. Wells Street, Chicago.
810 North Second Street, St. Louis.
122 & 124 Sutter St., San Francisco

HELME & McILHENNY,

(Successors to Harris & Brother. Established 1848.)

GAS METER MANUFACTURERS,

CONTINUE AS HERETOFORE AT THE OLD ESTABLISHMENT,

Nos. 1339 to 1349 Cherry Street, Philadelphia, Pa.,

To Manufacture Wet and Dry Gas Meters, Station Meters, Experimental Meters, Meter Provers, Center Seals, Pressure Registers

GOVERNORS, INDICATORS, PHOTOMETERS, & ALL OTHER KINDS OF APPARATUS FOR USE IN GAS WORKS.

From our long practical experience of the business, and from our personal supervision of all work, we can guarantee all orders to be executed promptly and in every respect satisfactorily.

WM. WALLACE GOODWIN, Prest. and Treas.

WM. H. MERRICK, V.-Prest.

S. L. JONES, Sec.

S. V. MERRICK, Supt.

THE GOODWIN GAS STOVE AND METER COMPANY,

Successors to W. W. GOODWIN & CO.

1012, 1014 and 1016 Filbert St., Phila., Pa.

142 Chambers St., New York.

76 Dearborn St., Chicago, Ill.

WALDO BROS., Agents, 88 Water St., Boston.

MANUFACTURERS OF THE "SUN DIAL" GAS STOVES, FOR COOKING AND HEATING PURPOSES.

Dry and Wet GAS METERS, Station Meters (Square, Cylindrical or in Staves) Glazed Meters, King's and Sugg's Experimental Meters, Lamp Post Meters, Etc., Etc., Meter Provers (sizes 2, 5 and 10 feet), Pressure Gauges of all kinds, Pressure Registers, Pressure and Vacuum Registers, Pressure Indicators (sizes 4 inch, 6 inch and 9 inch), King's Pressure and Vacuum Gauges, Dry and Wet Centre Seals, Dry and Wet Governors, Exhauster Governors, Photometers of all descriptions. Letheby's Sulphur and Ammonia Test Apparatus complete—also Testing and Chemical Apparatus of all kinds, and of the most perfect description, for all purposes relating to Gas.

GOODWIN'S IMPROVED LOWE'S JET PHOTOMETER.

Agents for Bray's Patent Gas Burners and Lanterns.

Special attention to repairs of Meters, and all apparatus connected with the business.
All work guaranteed first class in every particular, and orders filled promptly.

G. B. EDWARDS, Mang'r, New York.
E. H. B. TWINING, Mang'r, Chicago.
Represented by A. B. STANNARD.

D. McDONALD & CO.,

GAS METER MANUFACTURERS.

(Established 1854.)

51 Lancaster St., Albany, N. Y. 34 & 36 West Monroe St., Chicago, Ill.

STATION METERS, EXPERIMENTAL METERS, METER PROVERS, PRESSURE & VACUUM REGISTERS, PRESSURE GAUGES, ETC.

Also STAR GAS STOVES, RANGES, and HEATING STOVES.

We use only the very best materials, and employ the most skilled labor, and by our long experience (29 years) and personal supervision of every detail, we feel justified in assuring the public that our goods will give perfect satisfaction. Every Meter emanating from our establishment will bear the State Inspector's BADGE, and will be fully warranted by us. Our Annual and Calendar will be sent to Gas Companies upon application.

GAS ENGINES.

GAS ENGINES.

GAS ENGINES.

THE "OTTO" GAS ENGINE.

Guaranteed to Consume 25 to 75 ANY OTHER GAS ENGINE
Per Cent. LESS GAS than PER BRAKE HORSE POWER.

TWIN ENGINES Impulse every revolution.
THE STEADIEST RUNNING GAS ENGINE YET MADE.

ENCINES AND PUMPS COMBINED,

For Hydraulic Elevators, Town Water Supply, or Railway Service.

Special Engines for Electric Light Work.

OVER 15,000
IN USE.

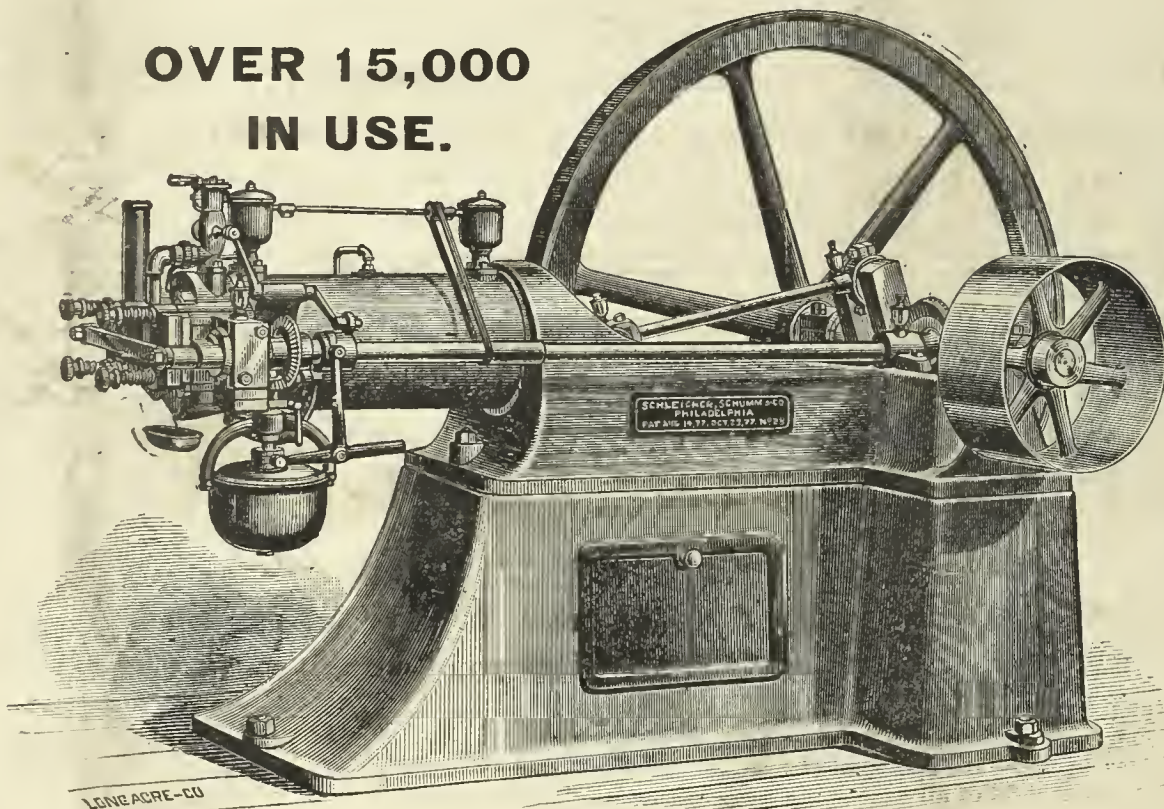

The Otto Gas Engine is now consuming, at a moderate computation, 2000 millions cubic feet of gas per year, nearly all of which is furnished during day time only.

**THE ONLY HIGHEST AWARD, ONLY GOLD MEDAL,
AT ELECTRICAL EXHIBITION, PARIS, 1881.**

MADE IN SIZES FROM 1 TO 25 HP. INDICATED.

FOR PARTICULARS, PRICES, ETC., APPLY TO

SCHLEICHER, SCHUMM & CO.,

Works:

Branch Office:

N. E. Cor. 33d & Walnut Sts., Phila., Pa.

130 Washington Street, Chicago, Ill.

THE AMERICAN

GAS LIGHT JOURNAL

PUBLISHING OFFICE No. 42 PINE STREET

DEVOTED TO THE INTERESTS OF ILLUMINATION, VENTILATION, WATER SUPPLY AND DISTRIBUTION, & GENERAL SCIENCE.

VOLUME XLVI.—No. 3.
Whole No. 663.

NEW YORK, WEDNESDAY, FEBRUARY 2, 1887.

{ \$3 PER ANNUM,
IN ADVANCE.

A. M. CALLENDER & CO., Proprietors. C. E. SANDERSON, Manager.
JOS. R. THOMAS, C.E., Editor. T. J. CUNNINGHAM, Asst. Editor.

ENTERED AT THE POST OFFICE AT NEW YORK, N. Y.
AS SECOND CLASS MATTER.

CONTENTS.

An Asterisk (*) denotes an illustrated article.

OFFICIAL NOTICE—

Annual Meeting of the New England Association..... 65

EDITORIALS—

Should the Supply of Water Gas Fuel be Permitted?..... 65

The Annual Meeting of the New England Association..... 66

Death of Mr. Wm. Merrick..... 66

Gas and Electric Lighting Supply: Shall They be Combined? by
Jos. R. Thomas..... 67

* Liquid Fuel, by Lewis T. Wright..... 67

The Destruction of a Philadelphia (Pa.) Theater Traced to an In-
candescent Lamp..... 70

Pittsburgh, Pa., as Seen by an Englishman..... 71

How to Make an Analysis of Sulphate of Ammonia..... 72

An Ingenious Automatic Fire Kindling Device..... 73

Special English Correspondence..... 73

Gas as a Domestic Servant—Smokeless Fires—Mr. Lewis T. Wright on
Liquid Fuel—Annual Reviews—Young's Ammonia Purification Process.

ITEMS OF INTEREST FROM VARIOUS LOCALITIES..... 74

Annual Election—Election of Trustees—A Waif from Wilmington, Del.—
Something from Tyrone, Pa.—A Line or Two from Bro. Stein—Altoona (Pa.)
Has the Electric Light—An Answer to Several Inquirers—Annual Election,
Danvers (Mass.) Gas Company—No Consolidation Intended—Named as West-
ern Agent—Chosen for the Presidency—To Extend a Charter—Annual Elec-
tions, at Frankfort, Ky., and Newport, R. I.—Brother Rollins Still at Work—
The Bouton Foundry Company—Partial Destruction of a Gas Works—To
Take Charge at Marlboro', Mass.—A Word from Dallas, Texas—Paying the
Piper—Personal—Beginning the "Aggressive Warfare"—Denied a Charter
—Annual Election—An Acknowledgment—The Yonkers (N. Y.) Gas War—
More Pay for other Pipers—Electric Lighting at Rahway, N. J.—Capital In-
creased—A Few Figures from the Report—Mr. Hinman's Annual Report—A
Proposed Tax on Gas Supply in Virginia City, Nev.—Mr. J. L. Hallett to Suc-
ceed the Late Mr. Merrick.

A Portable Coke Stove..... 77

Annual Meeting of the Brookline Gas Company..... 77

CORRESPONDENCE—

Mr. Egner, in Reply to "A. S."..... 77

The Market for Gas Securities..... 78

[OFFICIAL NOTICE.]

Annual Meeting of the New England Association.

The Seventeenth Annual Meeting of the New England Association of Gas Engineers will take place, at Young's hotel in Boston, on February 16 and 17, 1887. The meeting will be called to order by the President, Mr. John P. Harbison, on Wednesday, at 10 o'clock, A. M.

This meeting bids fair to equal any which have been held in past years. From the letters received by the Secretary, a great deal of interest is felt, and the attendance promises to be large.

Six papers have now been promised by the following gentlemen:

Mr. C. J. R. Humphreys, "Some Thoughts on Purification by Oxide;" Hon. A. M. Norton, "Effects of Reduction in Price of Gas;" Mr. E. G. Pratt, (subject not given); Mr. C. F. Prichard, "Candle Power and Illumination;" Mr. F. S. Richardson, "On Introducing High Candle Power Burners;" Mr. R. B. Taber, "Candle Power and Illumination."

From the well-known character of these gentlemen, it is safe to say, a very interesting set of papers will be presented.

It is proposed to send each member of the Association a short synopsis of

the papers, a few days before the meeting, so that all can come prepared to take an intelligent part in the discussion.

It is hoped and believed that the facts that will be brought out in the papers and the discussions, will add a material quantity to the present knowledge of the gas business.

CHARLES H. NETTLETON, Sec'y.

SHOULD THE SUPPLY OF WATER GAS FUEL BE PERMITTED.

Despatches from Troy, N. Y., bearing date of Jan. 17th, were well calculated to attract widespread attention, but the notoriety secured was gained at a most painful expense. Three persons were destroyed when seemingly engaged in ordinary conversation, while over a score of others were more or less severely prostrated, and the cause of all this suffering was instantly traced, once the wheels of investigation were put in motion, to an accidental inhalation of the fuel water gas distributed from the works of the Troy Fuel Gas Company. Briefly stated the leading facts appear to be the following:

About 7 P. M., on Sunday, January 16th, a young woman (Rose Stone) employed as a domestic in a restaurant owned by C. C. Howe—it is located in the Crowley building, on south side of River street, and quite close to the manufacturing plant of the fuel gas works—was seized with a seemingly inexplicable fit of illness. Bewildered and apparently unable to make known her condition to those close by, she rushed into the open air, gaining egress to the rear yard through an open doorway, and fell to the ground in a fainting condition. Jno. Talmage, a son-in-law of the restaurant keeper, startled by the strange conduct of the girl, Stone, followed closely in her wake, and at once instituted measures for her revival. A young daughter of Talmage was now taken sick, and the father, who speedily succeeded in his attempts at restoring the first victim to consciousness, while performing similar offices over his daughter, succumbed. The restaurant keeper (Howe) who was in another portion of the house, was found by Mrs. Talmage—she seems to have been the one who suffered least—in a dazed condition; and he exclaimed to her, "I guess I am going to die." To make an end of the preliminary statement, eleven persons in the Howe domicile were more or less prostrated, and all complained of similar symptoms—headache, nausea and drowsiness. A physician (Dr. Martin) was summoned, and he rather astonished the inmates of the plague-stricken spot—temperature of the outer air was extremely frigid—by at once throwing open all the windows and doors. Turning his attention to the sufferers, Dr. Martin explained to them that they had inhaled gas, which they stoutly denied. No gas was used on the premises, and none of the odors characteristic of gas had been perceived by them. However, the Doctor on previous occasions had been called upon to relieve similar cases, and he asserted that the street pipes of the fuel gas company must have been fractured. That being the case, the escaping gas—the top crust of the earth being frozen stiff—followed through the lower strata and entered the cellar of the restaurant, subsequently finding its way to the upper apartments of the building. The gas—it is a simple uncarburetted fuel gas, manufactured under the Lowe process—being odorless, performed its work unperceived by the sense of smell. The houses Nos. 395 397 River street were next examined. The first, a saloon, was found to be untenanted—Dr. Martin arrived on the scene at 9 P. M., and the outside investigation was commenced, say, at 10 P. M.—but a startling state of affairs was brought to light at No. 397. The front door was locked, but the investigators entered a side alley, ascended a narrow flight of steps that led to a

covered porch and landing and stood before a door opening into the second floor. This was locked, but, repeated knocks failing to elicit a response, the barrier was broken down and an entrance effected. In the kitchen was seen the form of an elderly woman, apparently asleep in an arm chair. A set of false teeth was clenched in one hand, but there were no evidences of a life and death struggle. However, the woman was dead. Hurrying on to the front apartment, the dead body of a second female, lying on the floor with a blanket wrapped around her, and a tin slop bucket placed near her head—she had evidently tried to vomit but could not—was discovered. In the same room, sitting upright on a lounge, with fingers locked and his hands resting on his knees, was found the dead body of a male person. The corpse was dressed in ordinary clothing, with the exception that the feet were shoeless. The victims were subsequently identified respectively as Mrs. Caroline Bennett; her daughter, Mrs. Wm. Gilfillan; and Charles Pratt, a visitor of the younger woman. At No. 397½ and several other houses on the line of River street the inmates had suffered more or less severely; but fortunately knowing to what cause to attribute their illness, these adopted proper measures for relief.

At the instance of Dr. Martin, shortly after his arrival at the Howe restaurant, word of the break in the mains was sent to Supt. Geer at the fuel company's works, and the current was at once shut off. One of the most peculiar features of the case is the varying manner in which different physical systems were affected. Mr. Barnes, an electrician, was reduced to such an extremity that he was only saved by the presence of mind of his wife, who, to use Mrs. Barnes' words, "put the battery on him;" but Mrs. Barnes herself, subjected to precisely the same influences that prostrated her husband, and hovering over his very person, was affected but slightly—that is, when compared to the state to which he was reduced. It might be explained that Mr. Barnes and his wife reside at 399 River street.

To recapitulate, it seems that not less than 20—in all probability 30 would be nearer the mark—persons were more or less affected by the gas, and that 3 victims answered with their lives. It is horrible to contemplate what the actual result would have been did it so happen that the gas failed to manifest itself, or rather to reach to the altitude gained by it at 7 o'clock, until, say, four hours later, or when those subjected to its insidious attack were wrapped in sleep. Troy would have been treated to a genuine holocaust, save that instead of the victims having been destroyed by fire fuel gas would have been the responding destroyer. There can be no quibbling over the Troy disaster. The proper source is made plain through the result of the coroner's preliminary investigations, and in the subsequent admissions of Mr. Geer, of the Fuel Gas Company, as well. In fact, perhaps the results developed at the autopsy ordered at the coroner's request have never before been paralleled in this or any other country. Drs. Bouticon and Morris, while in the act of opening the bodies, were nearly overcome by inhaling the gases that escaped from the vitals of the subjects, and in fact the first-named physician was so seriously affected that he had finally to retire from the operating room before the dissection was completed. It should be borne in mind that the occurrence of January 16th was not the initial warning that had been given to the people of the city in the matter of the noxiousness of the gas sent out from the offending establishment. Plenty of such warnings had been received, notably one that, if memory serves aright, occurred on January 5th. On that date—luckily the affair happened shortly before noon—some 15 persons were more or less affected from inhaling gas that had entered their stores and houses in a manner precisely similar to the way recounted above. Again, on a day in last fall, many of the workers in the laundries—the operators of these establishments are extensive users of the fuel gas—were stricken down from the effects of the gas. But these latter instances attracted no particular attention, simply because no fatal results ensued. The latest disaster, however, provoked prompt action, and at a special meeting of the Council, held on January 18th, the franchise granted the fuel company was suspended; but in justice to the managers of the company it should be explained that they voluntarily suspended active operations prior to the Council's action. Judging from the present temper of the Troy authorities it is quite likely that an exhaustive examination of this subject will be carried out to completion, and the final outcome will be awaited with interest.

While not desirous of influencing or anticipating the verdict which will ultimately be arrived at, we submit that the case as it stands looks bad for the fuel company. The Superintendent, Mr. Wm. Geer, is reported by the *Troy Daily Times*, in its issue for January 17th, to have said, in the course of other explanations volunteered by him in regard to the terrors of the previous day: "We used the old steam heating company's pipes"—the fuel company purchased the plant and franchises of the defunct Troy steam heating company—"in some places, and that caused the trouble. We have had no break in our cast iron pipes; they don't leak. All the trouble is with the wrought iron pipes. There is an odor to the gas, but it is so faint that it can scarcely be detected near a fixture where there is a leak. Our gas can be odorized by putting in naphtha or carbolic acid." If Mr. Geer is report-

ed correctly, and there is no reason to doubt it, his employers will be called upon to shoulder a grave responsibility. They permitted the use of mains, notoriously defective, for conveying in large quantities and at heavy pressures an odorless (or practically so) gas which certainly carries in it not less than 40 per cent.—we are convinced, from the mode of manufacture pursued at Troy, that 50 per cent. would be nearer the truth—of the virulent poison, carbonic oxide. Further, the promoters (through Mr. Geer, who ought to know about it, if anyone does) admit that a distinct odor could be imparted to the gas by treating it with either naphtha or carbolic acid; but as neither the one nor the other of these substances was employed, we can draw but one conclusion. That conclusion is, naturally, predicated on the fact that the cost of the impregnated article would be in excess of the "unadulterated" product, whose baneful potency will be vividly remembered in Troy for many a day. It is needless to say that cheap fuel gas is a desideratum; but we are not prepared to admit that its importance is of such pressing moment as to call for the vending of an article, even be the methods of its distribution approximately secure, that takes foremost rank in the list of poisons. In taking present leave of this disagreeable subject we would remind our readers that, despite the immense quantities of fuel gas used in the regions where natural gas is obtainable, we have yet to hear of a single death from gas asphyxiation in those localities; and is not that immunity fairly attributable to the fact that analysis reveals an extremely low content of carbonic oxide in the gaseous product evolved from nature's laboratories?

[Since the above was written the verdict of the coroner's jury has been received. It attributes the disaster to the negligence of the fuel gas company, and recommends that an exhaustive examination be made by the authorities.]

THE ANNUAL MEETING OF THE NEW ENGLAND ASSOCIATION.

The forthcoming annual meeting of the New England Association—the Seventeenth yearly gathering it will number on the roster—bids fair to be a more than ordinarily interesting session. In the first place, we can expect to hear something of importance and interest from the lines of President Harbison's inaugural address, and we can, from our understanding of that gentleman's skill and ability, added to his thorough knowledge of, and adroitness in, the matter of guiding large gatherings safely through the mazes and meshes of parliamentary law and rulings, predict that the gavel is to be wielded by a master hand. But even though the directing reins are sure not to sag listlessly over the footboard, the road would seem long were we not sure of a succession of changes by the wayside. These "changes" will no doubt be pleasantly supplied by the authors who have signified to Secretary Nettleton their intention of contributing papers. As this list, or a partial one at least, has appeared in the Secretary's official announcements, printed from time to time in our columns, we must leave our readers to decide whether or not the literary pabulum will be fit for the feast. We cannot forbear, however, in expressing our gratification at seeing Mayor Norton's name down for a paper, and he surely will throw some light on that vexed question, "Effects of Reduction in the Price of Gas." The members, of course, will see to it that Secretary Nettleton's hope, in regard to a large attendance, will become a certainty when President Harbison's gavel proclaims the opening of the sessions.

DEATH OF MR. WM. MERRICK.

Not quite a year ago we were called upon to chronicle the sudden decease of Mr. James Dwight Brewer,* who, a fortnight before, had refused to accept a re-election to the treasurership of the Springfield (Mass.) Gas Light Company. The office thus vacated was filled by Mr. Wm. Merrick, son of Solyman Merrick, the latter gentleman having been the first occupant of the Presidential chair of the Springfield Company. The now-deceased son maintained intact his father's interest in that enterprise, and, as said before, succeeded the late Mr. Brewer. The subject of this brief note was born in Springfield, Sept. 10th, 1849; took his preparatory course at Prof. Charlier's New York Academy, subsequently graduating from Harvard in the class of '70. He afterwards completed a course in architecture at the Boston Institute of Technology. We have no record that he ever married, but at any rate his next of kin is an aunt. Deceased lived an extremely simple, unostentatious life, and, therefore, in saying the above we have about exhausted his history in so far as it relates to that which the public has the right to hear. However, if his life was simple, it was also beautiful and peaceful—filled with harmony and void of passion. That he was generous is best illustrated by uncovering the secrets of his will, which instrument provides for the equitable distribution of a large estate. To show how his fellow workers held him we here reprint the closing paragraph of a set of resolutions passed by the Board of Directors of the Company he had served:

"Resolved, That in Mr. Merrick's death this Company loses a valued and efficient servant; its patrons a courteous and accommodating officer; this city a generous and exemplary citizen; and humanity a friend."

* Mr. Brewer died on Feb. 7, 1886; and Mr. Wm. Merrick's death occurred on Jan. 17, 1887.

[A Paper read before the Society of Gas Lighting.]

Gas and Electric Lighting Supply: Shall they be Combined?

By JOS. R. THOMAS.

A subject now being seriously considered by many of the most studious and prominent gas engineers of our country is the following: "Will it be for the best interests of the companies we represent to install an electric lighting plant as an adjunct to our apparatus for making gas, in order that we may be in position to furnish either or both descriptions of light wherever the same may be called for?"

A satisfactory solution of the foregoing problem can only be achieved by patient study and careful analysis, for the first step involves the traveler in the necessity of pointing his course over roads unmarked by the guide posts that hitherto led him on in security. The often flippant, and always boastful, claims of those who, for lack of better description, may be termed "commercial electricians," are one thing, and you will readily grant me cannot, therefore, be accepted as sufficient guides to convince us of the "straightness of the path." Hence we must yet grope our way, and be content even if our ratio of progress is but slow; for it should be borne in mind that the race is not always awarded to the swift.

Much may be said in favor of an affirmative answer to the afore-mentioned query, and possibly about as much may be urged in the negative; but a prime factor that must enter into the consideration and decision of the question, in every case, is the situation and surroundings in which the individual questioner finds himself placed. Local circumstances, therefore, must alone determine the nature of the step to be taken. That this is so is instantly apparent when we come to compare the views of gas managers who have thought about the matter. Some are unhesitatingly prompt and enthusiastically certain over the benefits to be derived from the working of a combined plant; and their prognostications as to the future of the artificial lighting business are leavened by the assertion that if success is to be maintained the dual system must be pursued. On the other hand we find that about as many are disposed to reject the rose-colored presentation of the subject, and the opponents shade their belief with more somber hues; but these, while indisposed to concede that the combined plan is necessary for the future preservation of their lighting supply supremacy, are willing to admit that the new departure may in some respects be accepted as holding forth valid reasons for its adoption. Again, we find a third division, whose supporters with blind persistence refuse to consider the question in any shape or form, and thus ignore the thing completely. It is not my province to say which of the three classes contains the orthodox set; but I may be permitted to enroll myself in the ranks of the middle division, and to frankly confess that my conversion from the "faith of the stubborn" is of comparatively recent date.

With such a variety of opinion existing, it would seem that a final settlement of the matter is well under way, for honest antagonisms, heterodoxical as that may sound at first, are but the struggles of those who seek the truth.

It is a plain matter of fact, and so well worthy of consideration as a cause for hastening decision, and its remembrance may help to that end, that the business of electric lighting has made rapid progress in our cities, towns, and even villages during the past two years. I do not propose to weary you with the ways and means by which this progress has been effected, or to retell the corrupt methods unfortunately so often pursued by the public authorities in connection with their government of even the smallest localities. But if that progress was, in some or any measure, fostered by corruption, it nevertheless was effected; and so we must accept it as an issue of the day and time. To explain here, the writer does not wish to be understood as asserting that, so far at least, the advance in electric lighting has been secured at a corresponding loss to the craft of the gas maker in the matter of the latter's sendout. On the contrary I think, and have reason to know, that the electric lighting furor has created a desire for a greater volume of light. The people, as a rule, would not be satisfied now with the amount of illumination that they formerly accepted as sufficient for their needs, and the revolution can be traced, in great part at least, to the brilliant if pale glare of the voltaic arc.

One important effect upon the gas industry in any city or town blessed by the possession of two or more competing electric lighting companies is that the local gas supplier is as liable to suffer from the effects of that struggle for business as if he were himself engaged in the strife. In fact, I believe the situation in which he is thus placed is nearly identical to what would be caused from the efforts of a competing or opposition gas company. Under such circumstances the owners of the gas company, in order to protect their interests, might see their way clear to taking a hand in the contest by adding an electric plant to their apparatus. One of the greatest inducements, however, to cause the operation of a combined plant—particularly in our larger cities—is that we find quite a number of consumers who are evidently earnest in their desire for electric light. These say they want it under any circumstances, and will have it at any price; and since it is quite useless to

seek to curb the ways of fashion, one may take advantage of its foibles in order to extract profit from ministering to its weaknesses.

It is of course certain that if electric lighting can be furnished so as to prove remunerative to distinct individuals or to incorporated assemblies, owners of gas companies can supply it still more advantageously, in that they can work more economically. A slight glance at the conditions existing proves the last proposition. There are very few gas companies in this country with whose ground plan I am familiar that are not possessed of sufficient space to admit of the installation of an electric lighting plant. Many of them own buildings well adapted, without the need of a single change, for the purpose, while others would require only a very slight expenditure to fit them exactly for their new duties. Some of the surplus fuel, which at times is a mere drug on their hands, could find a ready outlet in the new order of things, and thus a better and more stable market be maintained for the balance. The clerical work required to keep up the accounts of the new departure could be found nearly, if not quite, in the staff already maintained; and so it would be in almost every practical item connected with the added establishment. It would seem, therefore, that the extra expenses or charges to be incurred in the installation by gas companies of an electric plant would be: Capital and interest; cost of plant and wear and tear of same; labor required in production and distribution. These items would have to be charged against an independent electric company, whereas the latter would not have the compensating or decreasing offsets of cheap fuel, no salaried officers, no office or ground rent, etc., that would adhere to the proprietors of the combined gas and electric light undertaking.

In thus setting forth my views I wish to be distinctly understood that not a doubt exists in my mind on the subject that gas, for illuminating purposes, in respect of volume for volume of light, can be furnished much more cheaply than can electricity. The absurd statement made by one or two of the incandescent promoters, that their pet light can be made to successfully compete with gas sold at the rate of \$1 per thousand cubic feet, should be accorded the credence given to the recent claim of a "wild westerner" who is now ready to furnish any company with a gas making plant guaranteed to produce an illuminating vehicle, of extraordinary diffusibility and high candle power, that can be placed in the holder at a cost not to exceed six cents per thousand cubic feet. The only wonder is that these visionaries find seemingly sensible people who will waste time and money in the investigation of such patented fallacies.

That great improvement has been made in the matter of perfecting electric lighting apparatus we all must admit, and one pleasing effect of that advance has been the impulse given to inventors at work on the problem of developing the inert (for want of a better term) properties of gas. While the matter may be considered foreign to the subject of the present paper, and even at the risk of seeming to improperly advertise anyone's wares, I will venture to recall to your mind the exceedingly beautiful illumination of a portion of the Hotel Lafayette, Phila., Pa., during the progress of the last annual meeting of the American Gas Light Association. The Lungren burners employed on that occasion show what may be accomplished by an intelligent use of gas, and I regret to add, speaking for New York city, that a greater number of them are not to be found in operation there. Neglect or indifference on the part of gas men accounts somewhat for the hold obtained by the electric light, and no matter whether you decide sooner or later to embark in the business of conjoint gas and electric light supply, do not foster the latter at the expense of the former, for it is, after all, as gas makers that you must count for success. Granting that electricity, as officially stamped by one who made incandescent lighting a practical success—Mr. T. A. Edison—is the light of the rich, gas is now more than ever the light of the poor—a state of affairs which is not sought to be changed by those interested in its manufacture and supply.

Liquid Fuel.

By LEWIS T. WRIGHT, F.C.S.

[A paper read by the author—who is General Manager of the Nottingham Corporation Gas Department—before the Nottingham Section of the Society of Chemical Industry, on Monday, Dec. 13, 1886. For our report of same we are indebted to the *Journal of Gas Lighting*.]

In 1883 I had the honor of addressing the Manchester Section of this Society on the subject of "Gaseous Fuel"—a subject then of absorbing interest, and the theme for numerous papers. The attention of the technical world now seems likely to turn to "liquid fuel," since we are threatened with a deluge of petroleum, which would, no doubt, be an accomplished fact if it were possible for this material to be delivered at such a price as to enable it to compete with our cheap English coals. The excellent paper read before the London Section of this Society in 1885, on "The Russian Petroleum Industry," by Mr. Boverton Redwood, has given us an idea of the enormous quantities of petroleum seeking a market; but we have yet to learn the lowest price at which it can be delivered in this country, for on the price de-

pend, of course, whether or not it can successfully compete with coals. Mr. Redwood states that at Nobel's works 1 lb. of petroleum residue evaporated 14½ lbs. of water in a boiler provided with Nobel's trough burner, and 12 lbs. when injected into the furnace by steam; whereas coal was only equal to from 7 to 8 lbs. of water. It is probable that the coal employed was not of the finest quality. I do not know what the constitution of the petroleum residue may be; but the higher classes of petroleum are surely the most concentrated fuel, weight for weight, we can hope to find. Whilst the American petroleum oils are principally hydrocarbons of the paraffin series, the Russian appear to be mostly pseudo-olefines, naphthalines, and benzine oil hydrocarbons. You will remember that the hydrocarbons of the paraffin series up to heptane have positive heats of formation; and from the regular progression presented by these bodies, as far as they have been investigated, we may conclude that the higher members of the series also have positive heats of formation, and yield on combustion less heat than would be indicated by their elementary composition, or calculated according to Dulong's formula. Methane, the first member of the series, yields on combustion about 11 per cent. less heat than would be given by the same amount of carbon and hydrogen in the free state; hexane, about 6 per cent. less. The members of the olefine series at present studied have either negative heats of formation or very small positive ones. Of the acetylene series, the two first members—viz., acetylene and allylene—have negative, and diallyl (C₆H₁₀) a small positive heat of formation. Naphthaline, anthracene, and benzine appear to have negative heats of formation. I mention these matters as I think it probable that, carbon for carbon, and hydrogen for hydrogen, the Russian will be found to yield more heat than the American petroleum.

As engineers, we labor under the difficulty of being compelled to employ an empirical formula for the calculation of the combustion equivalents of our fuels; and this difficulty can only be removed when the chemists have had time to determine for us the true calorific values of the materials we employ as fuels. Until then we shall have to avail ourselves of Dulong's formula, with the mental reservation that it is likely to give results perhaps 8 per cent. from the truth. It is well known that most coals at present investigated yield in the calorimeter higher results than are obtained by calculation. However, there are exceptions. I find that 14 coals examined by MM. Scheurer-Kestner and Meunier in their calorimeter give an average result 9 per cent. in excess of the average calculated values. The coals examined by Herr Ferd. Fischer in his boiler trials also gave about 7 or 8 per cent. more in the calorimeter than was calculated from the elementary composition (Wagner's *Jahres-bericht*, 1883 5). I have not had any experience of petroleum as a fuel; but I venture to make a theoretical comparison between it and coals. The average composition of 15 petroleum from various parts analyzed by M. Sainte-Claire Deville was—

Carbon	84.7
Hydrogen	13.1
Oxygen ..	2.2
	100.0

This gives a theoretical evaporative power per pound of 19.63 lbs. of water from a temperature of 100° C. at atmospheric pressure, reckoning the water formed on combustion of the hydrogen to be in the gaseous condition, thus—

$$\frac{84.7 \times 8080 + \left(13.1 - \frac{2.2}{8}\right) 28,780}{536.5 \times 100}$$

(The theoretical evaporative power will always be expressed on this basis.) In a good boiler we may expect to get into the water 80 per cent. of the calculated heat of combustion of such a class of fuel. We should then have an actual evaporative power of 16.74 lbs. of water; but as about 5 per cent. of the water evaporated would be required to operate the injector, if the petroleum were worked on this system, we should have a net evaporative power of 15.70 lbs. of water. This estimate gives petroleum, weight for weight, 39 per cent. more evaporative power than coal of a practical evaporative power of 11.3 lbs.

Mr. D. Kinnear Clark, in his "Manual of Rules and Tables," falls into a singular error in his notes on "Liquid Fuels," and credits some petroleum oils with a theoretical evaporative power of 29.08 lbs. A glance at the formulæ and elementary composition of his petroleum oils will immediately cause the error to be disclosed. In his otherwise useful manual the custom of calculating the combustion values of the fuels on the basis of the water formed on combustion of the fuel being liquid is objectionable, as it operates unfairly against those fuels which contain but little hydrogen, and is a condition not to be arrived at in practice. No doubt some of the purer petroleum distillates might give one or two pounds more than this figure; but would they not be commensurately dearer? A crude petroleum of .87 specific gravity would measure 257½ gallons to the ton of 2,240 lbs.; and at 1d. per gallon would be equivalent to a coal of the above-mentioned quality at 15s. 6d. per ton, without reckoning anything on account of a saving in labor of firing, and other advantages which liquid fuel possesses—such as

getting more work out of the boiler, etc. It is impossible to assign any value to these, as everything would depend upon particular circumstances. Of course, if it were found that trough burners could be successfully employed, then the comparison would be much more favorable to the petroleum; but petroleum at 1d. per gallon is at present a thing only to be dreamt of. There are other liquid or semi-liquid fuels produced in this country at a very low price—such as tar oils and tar; and the attention of engineers and manufacturers who require intense and regular heats should be directed to these.

The results of the boiler trials I have made with tar and creosote, and which were casually mentioned in a paper I read before the London Society on Nov. 1 of this year [1886], I now propose to bring before your notice. The results in the paper referred to were given for actual working conditions—viz., feed water at 12° C. (53.6° F.), and 40 lbs. steam pressure. The boiler was a two-flued Galloway boiler, 28 feet long, 7 6 feet in diameter, and of the best modern construction:

Class of Fuel.	Number of Days' Trial.	Water Evaporated from 12° C. at 40 lbs. Steam Pressure.	Water from 100° C. at Atmospheric Pressure.
Nottinghamshire top hard cannel	Eleven.	7.40	8.78.
Silkstone gas coal.....	Seven.	8.42	10.01
Coke from top hard cannel.....	Six.	8.34	9.91
Silkstone gas coke.....	Six.	9.49	11.15
Tar, steam injected.....	Seven.	10.70	12.71
Creosote, steam injected.....	Nine.	11.24	13.35

I give coals and coke in this table for the purpose of comparison.

I will now give the elementary composition of the materials employed, and their calorific values calculated according to the usual formula—

$$\frac{C \times 8080 \times \left(H - \frac{O}{8}\right) 28,780 - (H_2O \times 600)}{536.5 \times 100}$$

The carbon, hydrogen, oxygen, and moisture, etc., being expressed in percentages, and the results being given in units by weight of water evaporated from 100° C., and atmospheric pressure per unit weight of fuel.

The Nottinghamshire top hard cannel employed has the following elementary composition:

Carbon	67.0
Hydrogen	5.6
Nitrogen.....	1.2
Sulphur.....	1.0
Water	7.6
Ash.....	6.6
Oxygen	11.0
	100.00

$$\frac{67 \times 8080 + 28,780 \left(5.6 - \frac{11.0}{8}\right) - (7.6 \times 600)}{536.5 \times 100} = 12.27.$$

and would therefore have a theoretical evaporative power of 12.27 lbs. of water per pound of fuel.

The composition of the Silkstone coal was as follows:

Carbon.....	79.0
Hydrogen	5.2
Nitrogen	1.5
Sulphur	1.5
Water	4.0
Ash	2.8
Oxygen	6.0
	100.0

$$\frac{79 \times 8080 + 28,780 \left(5.2 - \frac{6.0}{8}\right) - (4 \times 600)}{536.5 \times 100} = 14.24$$

with a theoretical evaporative power of 14.24 lbs. of water per pound of fuel.

The top hard cannel coke was composed of—

Carbon	80.1
Hydrogen.....	0.6
Nitrogen	1.3
Sulphur	0.4
Water	4.1
Ash	11.9
Oxygen.....	1.6
	100.0

$$\frac{80.1 \times 8080 + 28,780 \left(0.6 - \frac{1.6}{8}\right) - (4.1 \times 600)}{536.5 \times 100} = 12.23$$

with a theoretical evaporative power of 12.23 lbs. of water per pound of fuel.

The Silkstone gas coke consisted of—

Carbon.....	89.0
Hydrogen.....	1.0
Nitrogen.....	1.0
Sulphur.....	1.2
Water.....	1.2
Ash.....	5.2
Oxygen.....	1.4
	100.0

$$\frac{8080 \times 89 + \left(1.0 - \frac{1.4}{8}\right) 28,780 - (1.2 + 600)}{536.5 \times 100} = 13.82$$

with a theoretical evaporative power of 13.82 lbs. of water.

The following was the composition of the tar:

Carbon.....	80.2
Hydrogen.....	7.0
Nitrogen.....	0.8
Sulphur.....	0.5
Oxygen.....	11.5
	100.0

$$\frac{8080 \times 80.2 + \left(7 - \frac{11.5}{8}\right) 28,780}{535.5 \times 100} = 15.06$$

with a theoretical evaporative power of 15.06 lbs. of water.

The creosote was composed as follows:

Carbon.....	87.4
Hydrogen.....	7.3
Nitrogen.....	0.3
Sulphur.....	0.5
Oxygen.....	4.5
	100.0

$$\frac{8080 \times 87.4 + \left(7.3 - \frac{4.5}{8}\right) 28,780}{536.5 \times 100} = 16.78$$

with a theoretical evaporative power of 16.78 lbs. of water per pound of fuel.

The following table gives the percentage of theoretical evaporative power actually obtained:

	Actual.	Calculated.	Per Cent.
Nottinghamshire top hard cannel....	8.78	12.27	71.56
Yorkshire Silkstone coal.....	10.01	14.24	70.30
Top hard cannel coke.....	9.91	12.23	81.03
Silkstone gas coke.....	11.15	13.82	80.68
Tar, steam injected.....	12.71	15.06	84.40
Creosote, steam injected.....	13.35	16.78	79.56

It will be observed that the coals come out low; the coke and tar very well; while the creosote occupies an intermediate position. It is also important to bear in mind that the coals examined by Scheurer-Kestner and Fischer were really 7 to 9 per cent. better than by calculation; but I cannot say that this would also apply to the coals used. The creosote results agree fairly with some I have had the privilege of seeing, that were obtained in the London district, and also in the neighborhood of Nottingham; but as I have no information about the boilers employed, a close comparison is not possible. Creosote is an excellent fuel for boiler firing, and easy to manipulate. It requires to be warmed if it contains much "tar salts," to dissolve the naphthaline, etc. Tar is rather more difficult to manage with ordinary forms of injectors, as the peculiar orifices employed are extremely liable to obstruction with this viscous fluid; and there is a tendency to produce smoke if the flow is irregular.

For the purpose of injecting these liquid fuels into furnaces a great number of injectors have been invented. If they materially differed in principle the study of them would be perfectly bewildering; but as they are almost all alike, their study is really very simple. The one on the table before you is perhaps the simplest form. It is one that I have designed, and have called a "spray burner;" and it consists of one tube, carrying the steam, placed at right angles to another carrying the liquid fuel, in the fashion of those scent sprays that were, and perhaps are now, very popular for distributing scent in rooms. These injectors are said to require about 5 per cent. of the steam made to work them, and suffer from the obvious difficulty of not being able to raise the steam wherewith to start themselves. A supplementary boiler fired by other means would have to provide this in the first instance. There is no doubt that the oil could be burned without steam at all, after the manner of Nobel's trough burner. I have tried an arrangement similar to the one I shall shortly describe for retort furnaces; but it was not large enough to be able to consume sufficient oil to evaporate anything like the usual quantity of water. Up to this point, however, the combustion of

fuel was very perfect, and gave great promise for an extension of the system. The flame from these oils is very fierce, and it is no doubt advisable to place a ring of firebricks as a lining for the parts of the boiler which are in the immediate vicinity of the flame, and firebrick shields in front of the first tubes, if the boiler is of the Galloway type. The grate also needs covering with either a dense bed of ashes or fire-tile; and the lower half of the flue below the grate should be closed with a metal shield. I am inclined to think it would be preferable, if the use of oil were intended to be permanent, to employ a fire-box of firebrick outside the boiler, with a furnace of the type to be described hereafter, and lead the flue into the boiler flues.

The attention of gas engineers has been forcibly directed to the use of tar as a fuel for the firing of retorts, now that this once high-priced material is suffering like everything else (but perhaps to a more marked extent) by what is called "depression in trade." In fact, it has in many places reached so low a commercial value that it is profitable to burn it as a fuel. Happily this is not the case at Nottingham; and our interest in tar as a fuel is more experimental, in view of what may happen if a further fall in tar products sets in. I have abandoned the use of steam injection for our experimental tar fires, in favor of another system I am going to describe. The steam injectors produce excellent heats, but are rather intermittent in their action; and the steam they require is a serious item, and not always available.

Tar being a pseudo-liquid fuel, in arranging for its combustion one has to provide for the 20 to 25 per cent. of solid carbon which it contains, and which is deposited in the furnace as a kind of coke or breeze on the distillation of the volatile portions, which are much more easily consumed than the tar coke. The tar fire I have adopted is one that can readily be adapted to an ordinary coke furnace, and be as readily removed, leaving the furnace as before. The accompanying sketch shows the arrangement. An iron frame *D*, standing on legs on the floor just in front of the furnace door, carries three fire-tiles on iron bearers. The top one, *A*, is not moved, and serves to shield the upper face of the tile *B* from the fierce heat radiated from the furnace,

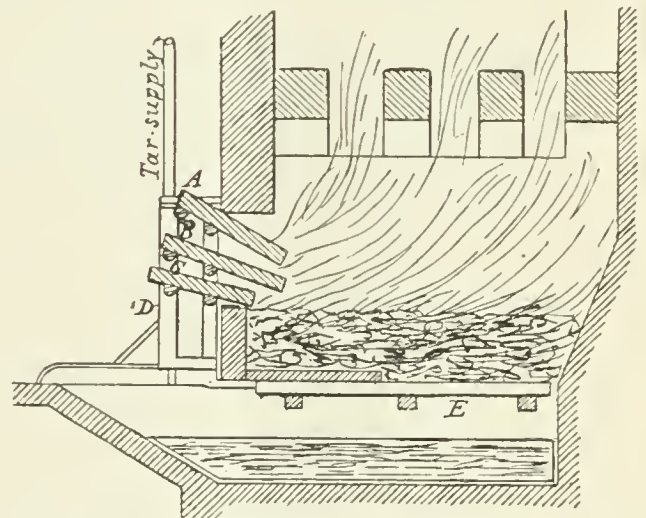

and also causes the air that rushes into the furnace between the tiles *A* and *B* to travel over the upper face of the tile *B*, on which the tar flows, thereby keeping it cool and preventing the tar from bursting into flame until it reaches the edge of the tile *B*, over the whole edge of which it is made to run fairly well by a distributing arrangement. A rapid combustion takes place here; but some unconsumed tar falls on to the bed below. About one-third of the grate area is filled up by a fire-tile, and on this the tar coke falls. The tile *C* is moved away from time to time, and the tar coke that accumulates in front of it is pushed back on to the fire-bars *E* at the back of the furnace, to be there consumed. Air is thus admitted, by three narrow slot-like openings, to the front of the furnace between the tiles *A*, *B*, and *C*, and under *C* and through the fire-bars *E*. The air openings below are about three times the area of the openings in the front of the furnace; but as the openings between the fire-bars and the tiles are always more or less covered by tar coke, it is impossible to say what the effective openings are. The disposition above described is found to work admirably, and requires but little attention. Three minutes per hour per fire seems to be the average; and the labor is of a very light kind, consisting of clearing the passages between the tiles, and occasionally pushing back the coke on to the fire-bars. These latter are not interfered with, and will not require cleaning unless any bricks in the furnace have been melted, when a bed of slag will be found on them.

The amount of draught required for these fires is very small, and less than with coke firing. I find that 0.08 inch vacuum is sufficient with tar fires, and 0.25 inch for coke fires. The fires would require less attention with more draught and larger tar supply, as the apertures do not so easily close with a sharp draught, and the tar is better carried into the furnace. A regular feed of tar is, of course, required; and considerable difficulty seems to have been experienced in obtaining this. So long as we employed ordinary forms of taps or valves, so long (even with filtration), did I experience diffi-

culties with the flow of viscous tar. But on the construction of valves specially designed for the regulation of its flow the difficulty immediately disappeared, and there is no longer the slightest trouble on this account. The labor connected with the feeding of furnaces with coke and cleaning fires from clinker is of a very arduous and heavy nature. Eight coke fires are normally considered to be work for one man; a lad could work sixteen of these tar fires.

Considerable attention has been paid to the composition of the furnace gases from the tar fires. The slightest deficiency in the air supply of course results in the immediate production of smoke; so that the damper must be set to provide always a sufficient air supply. Under these circumstances of damper, the following analyses have been obtained:

Analyses of Combustion Gases from Tar Fires.

No smoke.		
CO ₂ .	O.	CO.
11.7	5.0	Not determined.
13.3	3.7	"
10.8	5.4	"
14.8	2.5	"
13.5	3.0	"
12.4	5.6	"
12.4	4.6	"
13.1	5.9	"
15.3	1.0	"
10.8	4.0	"
14.0	2.8	"
<hr/>		
Average (11 analyses)..	12.9	3.9
<hr/>		
	11.5	Not determined.
	14.3	"
	14.6	"

Damper adjusted so that a slight smoke was observable in the combustion gases.

CO ₂ .	O.	CO.
17.30	None	Not determined.
16.60	None	"
16.50	0.1	"
15.80	0.1	"
16.20	1.8	0.7
<hr/>		
Average	16.48	0.4
		0.7

The Destruction of a Philadelphia (Pa.) Theater Traced to an Incandescent Lamp.

The *Exchange and Review* says that while theater fires were few in 1886, a notable instance of that sort accounts for a big blaze in Philadelphia, the last week of the year. At 11 A.M., Dec. 27th, while a moderate northwest breeze was blowing, fire broke out in the Temple Theater and Museum (the latter having wax-work figures, occupying four stories), fronting on Chestnut street, above Seventh, and in four hours totally destroyed the structure and content—building recently elegantly refitted—besides most of the stock of five large stores located on first floor, and causing much damage to roofs and upper stories of the adjoining Washington Hotel and buildings on Seventh street. Two firemen lost their lives by the falling of brickwork, and others were badly injured. Losses were sustained by thirteen different interests, aggregating \$208,000 of loss, in addition to the value of the building, a brown stone structure which had been erected as a Masonic hall.

Most of the losers were fully or fairly insured, except Mr. Singerly, owner of building and ground (purchase price \$400,000), and Mr. Brotherton, lessee of the theater and museum. The former considers that increased value of ground since purchase will diminish loss to about \$50,000 over his insurance. The latter had only \$8,000 insurance, and \$50,000 loss. Mr. Singerly's insurances aggregated \$97,375 in forty-nine companies, in amounts respectively from \$500 to \$10,000.

The fire commenced in the rear of the basement on Jayne street, among colored muslin drapery (as is supposed) of a booth in the Chamber of Horrors. It was quite slight at first, and was noticed in the drapery by a few persons, who made efforts to extinguish it, among other trials bringing a hose attached to a pump in the engine room, but the hose proved to be too short. For awhile it was believed that the fire was put out, and thus twelve minutes were lost, during which it crept to the wooden sheathing of an elevator well and ascended then quickly, finding in every story most combustible material in the numerous wax figures and their surroundings, reached the roof, and soon enveloped the whole interior. It is asserted by some that had the ignited drapery been pulled quickly down the incipient fire might have been extinguished. The prevalent opinion of those present at the ignition was

that the drapery took fire from an incandescent pendant electric lamp in the booth. The ignition might have happened from improper location of electric wires, or the occurrence of short circuit between two of such wires.

At the coroner's inquest (Jan. 11) testimony was taken as to the origin of this fire. Manager Brotherton thought an incandescent lamp fired the muslin curtain in front of a booth, but said the curtain was two feet from the lamp. The electrician who put in wires said they were not near the drapery. He was asked if he had not heard of a workman's coat having a hole burned in it through being hung on such a lamp, a year earlier, in the same building. He answered, he knew, but had forgotten it. One of the assistants said the flames at first covered a space of about 18 inches only of the drapery, but they got between the canvas top of the booth and the ceiling, and then spread rapidly.

A number of incandescent lamps and their wires had been introduced into the Coroner's office, and Inspector McDevitt, of the Insurance Patrol, illustrated how ignition could have happened if a fusible "safety" wire did not act when there was sudden excess of current. Attention was here called to the fact that the white smoke from burning insulating covering looked exactly like steam. The Inspector covered the glass globe of an incandescent lamp with several folds of a cotton handkerchief tied tightly around it, and in ten minutes after the current was turned on the handkerchief commenced to smoulder, and when blown upon by the breath broke into a blaze. As to the wiring, possible excess of current, and surroundings of the booth, Augustus Harmoning, an usher, who was explaining to visitors the figures in the Chamber of Horrors when the fire broke out, testified that a lady standing in front of the booth directed his attention to what she called smoke in the booth. He got into the booth, *saw no flame*, and a moment later one of the incandescent lamps burst. Immediately the canvas top and side caught fire. Witness had extinguished the gas in the basement ten minutes before. He thought he saw a sheet of flame run along the electric light wire inside the canvas after the globe exploded. He was not absolutely certain that the flame followed the wires, but it did move in a straight line.

Some of the wires in the building were found after the fire which had not been soldered at joints. Wm. T. Connor, an electrician employed in the establishment, stated that a steam pump used for hydraulic purposes was under the Chamber of Horrors, so contributing moisture to the atmosphere, and to deflections of the electric current. The testimony closed, but the jury had not agreed upon a verdict as we make this noting, and further testimony is promised.

For our* own satisfaction we made some trials respecting the normal heat of incandescent electric light bulbs, and the augmentation of such heat by impeding radiation. A Fahrenheit thermometer held with its bare bulb against the *side* of the glass enclosure of a 16-candle incandescent lamp where the carbon filament was three-quarters of an inch from the glass, rose to 161° in ten minutes. The thermometer bulb being then held to the *bottom* of the enclosing glass, where the filament was within one-quarter of an inch of the surface, the mercury marked 186° in ten minutes. A white cotton handkerchief, in four folds, was tied tightly around the glass enclosure of the same lamp, and in six minutes it smoked much, and blazed in eight minutes, as soon as blown upon. The moment the flame came the glass broke and the light went out. This, of course, does not represent the temperature of the glass enclosure as exposed to the air, nor does it evidence any possibility of ignition should any light, combustible material come in contact with such lamp.

[Since the above article appeared in print the coroner's jury engaged in investigating the origin of the fire made their presentment, on the afternoon of January 17th. They said:

"We, the coroner's jury on inquest, find that John Gibson, aged 31 years, residing at 2,026 Sansom street, and John Johnson, aged 38 years, residing at 616 South Ninth street, members of the Philadelphia Paid Fire Department, were killed by the falling on them of a wall at the Temple Theater, December 27, 1886, in the discharge of their duty at the fire which destroyed the Temple Theater and Musée on said date. We further find that there was no evidence of other cause of fire save electricity; that the fire was not due to incendiarism; that without proper workmanship, care and conditions, it is possible to cause fire by means of incandescent light circuits of low potential in many ways.

"The jury are under the greatest possible obligation to Inspector Wm. McDevitt, of the Insurance Patrol, for his skillful experiments, proving conclusively: 1st, That incandescent lamps will set fire to inflammable substances when the heat in them is confined and allowed to accumulate, and that the lamp need not break in order to do this.

"2d, That the breaking of an incandescent lamp will set fire to inflammable gases.

"3d, That the breaking of incandescent lamps does not ordinarily set fire to solids, even if quite inflammable.

* The proprietors of the *Exchange and Review*.

"4th, That water or moistened wood will 'short circuit' incandescent circuits, and cause fire in so doing.

"5th, That loose joints unsoldered are dangerous and liable to cause fires.

"6th, That the wearing away of insulation on twisted flexible leaders will cause fire, unless safety plugs are used.

"7th, That a careful system of safety plugs for all parts of a circuit, that thorough insulation of all parts of a circuit, that soldered joints and care not to place lamps so that heat can accumulate, are first requisites in a safe system of incandescent lighting.

"And we further find:

"The wiring, adjacent to inflammable canvas and curtains in the Temple Theater, was found to be so imperfectly done as to be dangerous.

"The origin of the fire in the Musée department of the Temple Theater was the incandescent light circuit.

"While we think it our duty to state the possible causes of fires by means of electric light circuits, we believe the risk of fire to be controllable and a minimum in the case of thorough workmanship by reliable companies."]

Pittsburgh, Pa., as Seen by an Englishman.

Engineering lately found space in its columns for the following interesting descriptive article concerning Pennsylvania's industrial hive:

The two great factors in the commercial prosperity of a district are the character of the inhabitants and the natural advantages of the locality. Given a skillful and enterprising race, living in a country well situated either for trading or manufacture, it is certain that they will accumulate wealth. Now, both these conditions are found in no ordinary degree at Pittsburgh. The inhabitants belong to the shrewdest and most pushing race on the globe, and have the advantage of the accumulated skill of several generations, and of the reputation which always attends success. They are located in the middle of a rich mineral region, which not only teems with coal and iron, but also spouts forth oil and gas and salt in a way which renders it one of the wonders of the world. It is covered with splendid forests, and is watered with majestic rivers, which provide it with power and means of transport. With such surroundings it needs no labored explanation to account for the rise of Pittsburgh, and no prophetic insight to foretell that a great future awaits it. It is the heir of wealth which will last for many generations, and the extent of which cannot be computed. Originally the coal and iron of the district seemed sufficient to provide for an enormous population; then the oil was discovered, and burst forth with a furious copiousness which unsettled the public mind, and gave rise to a tide of speculation which overran the entire country; finally, as if nature could put no bounds to her benevolence, it was found that the earth contained an immense store of combustible gas available as a universal source of light and heat, and ready to be employed for melting iron, heating forgings, generating steam, for warming, cooking, lighting, and all the purposes to which coal has hitherto been applied. What the future contains for Pittsburgh no one can tell, but for the sake of our descendants, for those on whom it will fall in years to come—when improved means of communication have practically reduced the dimensions of the globe, and the great Western States of America no longer offer a continually widening market—to maintain the commercial status of the British Empire, it is devoutly to be wished that the last surprise has been evolved from this Pandora's box, and that for the future Western Pennsylvania may be content with the advantages it already enjoys.

The resources of Pittsburgh and the vicinity are so numerous that it would take columns to describe them at length, and we must, therefore, content ourselves with a brief summary. We will commence with the geographical situation. The city is due west of Philadelphia, and almost west of New York, from both of which cities it is distant between 300 and 400 miles. But although comparatively so near to the Atlantic, it is yet in the Mississippi watershed, lying at the confluence of the Allegheny and Monongahela rivers, which fall into the Ohio. This latter connects with the Mississippi, and the two provide access to a million square miles of country, and through the Gulf of Mexico to the South American continent. Although 2,000 miles inland, measured along the waterway, Pittsburgh is a port, and at certain times in the year, when the rivers are full, can be reached by vessels drawing 20 feet of water. But although the mountains prevent direct water carriage between Western Pennsylvania and the Atlantic, the great lake system, which is but 150 miles distant, presents an outlet both eastwards and westwards. The railway facilities rival those offered by the rivers. The Pennsylvania Railroad, the Pittsburgh and Erie, the Pittsburgh Division of the Baltimore and Ohio, and Allegheny Valley, the Pittsburgh, Fort Wayne and Chicago, the Pittsburgh and Cleveland, and the Pittsburgh, Cincinnati and St. Louis Railways, besides others, all aid in carrying material and manufactures to and from Pittsburgh. The competition of these lines is a guarantee of moderate rates, while the number marks Pittsburgh as a distributing as well as a producing center.

The city is situated in the heart of the bituminous coal formation of the Appalachian field, an area of supply which is estimated at 15,000 square miles. It does a large coal trade with the States, to which access is had by the Ohio, the mode of transport being peculiar, and being technically known as "towing." The method employed is, however, far from what would be expected from the name. Ten to fourteen barges, coal boats and flats, and one to four boats filled with bunker coal for the trip, are securely lashed together and placed in front of the so-called tow-boat, with the exception of two, which are ranged alongside of it. This floating island, carrying 24,000 tons of coal, is propelled and guided by the tow-boat down the Ohio, and often as far south as New Orleans, going with the flood current, which runs from eight to ten miles an hour, sweeping round the bends, past the bridges, and through the narrow channels until it reaches its destination. In the season eight or ten of these cargoes will leave Pittsburgh in a day. The coal comes almost entirely from the collieries in the pools of the Monongahela river. There are about sixty-six firms at work getting coal on the river, their combined output being about 100,000,000 bushels per annum, or 4,000,000 tons. On the Pittsburgh, Cincinnati and St. Louis Railway, and Chartiers branch, there are sixteen collieries; on the Baltimore and Ohio Railroad, and on the Youghiogheny river, fourteen collieries; on the Pennsylvania Railroad, six collieries; on the Allegheny river, six; and in and around the city of Pittsburgh, eight collieries. Besides there are a number of mines not yet fully developed. Coke is made in the Connellsville field, which is near Pittsburgh, and measures 60 miles by 3 miles. Here is a bed of coal from which there is produced a coke famous all over the States, 4,000,000 tons of it being consumed annually. There are engaged in the manufacture 10,788 ovens.

But it is not so much with coal as iron that the name of Pittsburgh is associated. Throughout the counties embraced in the bituminous coal region there are to be found extensive beds of iron ore, and there are equally large deposits in the counties east of and lying along the bases of the Allegheny Mountains. The irons of the celebrated Juniata region are close to Pittsburgh, while to the west there are those of Eastern Ohio. The rich ores of Virginia will be accessible on the completion of the Pittsburgh, Virginia and Charlestown Railroad, while the ores and iron of Lake Superior and the Missouri can be brought by water carriage. A blast furnace was erected in Pittsburgh in 1792, but had a career of only two years. It was not until 1859 that the second furnace was built, but since that date eighteen others have been erected, varying in height from 62 feet to 87 feet. There are also five furnaces in the neighborhood, the aggregate annual output of the whole being 922,000 tons. Besides these there are thirty-five iron rolling mills, employing over 18,000 hands, and occupying 138 acres of land. They work up 670,000 tons of metal per annum into merchant bar, hoop, boiler plates, pipes, nails and rods. Steel is also made in large quantities, and has a high reputation. Exclusive of Bessemer plants, and rail mills, and steel casting works, there are twenty-three steel works, of which eight are strictly devoted to crucible tool steel. In the Bessemer trade there are three 10-ton converters, three 7-ton, three 5-ton, and two 2-ton converters, and these, it must be remembered, are much harder pushed in good times in America than in this country, owing to the system on which royalties are paid. In 1885 the output was over 300,000 tons.

But the crowning glory of Pittsburgh is its natural gas. Other lands have abundant coal and inexhaustible ore, but nowhere else are these associated with a vapor fuel which flows freely from the earth, and can be used without preparation, and apparently without stint. Its use has perfectly revolutionized the city, and has converted one of the grimmest places in the world into a comparatively clean town. The economies it realizes are difficult to learn, but in one steel plant it has been found that \$40,000 worth of gas did the work of \$96,000 worth of coal, with an attendant saving of \$12,000 in the transport of ashes, and of 25 per cent. in wear of the furnace. At a glass factory the gas has reduced the fuel expense by \$6,000 a year. At an iron works with nineteen heating furnaces, the saving is put down as \$6,500 in fuel, \$2,600 in transportation, and \$4,100 in repairs. The saving due to reduced oxidation is also great. The general opinion is that the saving in fuel cost is possibly 50 per cent., and the increased yield 15 to 25 per cent. There is also a distinct gain in quality of the metal, due to the absence of sulphur, and the terms "gas iron" and "coal iron" are beginning to appear in the market. The gas district appears to lie entirely within 30 to 40 miles of Pittsburgh, and the greater part of the wells are within 20 miles. The supply shows no signs of exhaustion. In the Murrysville district, which may be likened to a pepper bottle, so thick are the wells, a shaft sunk by the People's Company, in December, 1885—ten years after the first Murrysville well—exhibited the strongest flow ever seen in the district; and the original Murrysville well, although it has been blowing for ten years, is said to be as strong as ever. The gas was first used in Pittsburgh as manufacturing fuel in 1875-6, but its general adoption only dates from July, 1884, a fact which shows that great doubts were felt as to its permanence. At that time Mr. George Westinghouse, Jr., organized the Philadelphia Company

for the supply of gas fuel. At the present time 3,000 families, 34 iron and steel mills, 60 glass factories, and 300 smaller factories and hotels are using the gas. There are laid 336 miles of pipe, of which 66 miles lie within the city. Of this pipe 10 miles are 24 in. in diameter; 7 miles are 20 in.; 6 miles are 16 in.; 11 miles are 18 in.; and 14 miles are 8 in.

Of the minor features of Pittsburgh we cannot write, but those who are interested in them can find much information in "Pittsburg's Progress, Industries, and Resources," by Mr. Geo. H. Thurston, of that place, to whom we acknowledge our indebtedness for many of the facts mentioned above. We do not find, however, that he, or indeed any American author is quite frank in presenting the facts which tell against the credit of this favored city. He admits that it is grimy and black, and that it is exclusively a manufacturing place, devoid of beauty, but he does not tell us that its municipal and sanitary affairs are in a state which would raise a perfect storm of disapprobation in this country. The City Council is practically bankrupt, and all improvement is stopped for want of funds. Some years ago the authorities thought to do great things for the citizens without any additional taxation. They therefore bought land and waited for the rise, hoping to clear a handsome profit. But someone brought the matter before the courts, who decided that it was beyond the competence of the council to speculate in lands, and the lots had to be resold, at a bad time, with the result that now the city is saddled with a debt which consumes much of the rates. The limit of taxation allowed by law has been reached, and the consequence is that the place is without many of the needs of civilized life. There is no main drainage, and the use of cesspools is almost universal. Everyone gets rid of his sewage in the easiest way, and often this ends in the ground becoming thoroughly soaked and poisoned. The paving of the streets is execrable, and is made worse by being constantly broken up to lay the natural gas mains, when there is no effective control to oblige the companies to put it in good order again. We merely point out these facts to show that Pittsburgh is not perfect. We have no doubt that in a few years all these blots will be removed, and its domestic concerns will be put in a condition befitting its manufacturing position. It is no boast for a city to be wealthy, if it is not at the same time clean.

How to Make an Analysis of Sulphate of Ammonia.

Mr. N. H. Humphrys contributed the following interesting communication to the January issue of the *Gas Engineer*:

Having been requested to give an account of the simplest method for analyzing this substance, suitable for gas managers who are not experienced analysts, and have not the resources of a complete laboratory at command, I would first remark that there is no royal road to accurate laboratory work, and that the necessary manipulative skill for the efficient carrying out of even such a simple chemical experiment, as that about to be described, cannot be obtained without a reasonable amount of practice. The tyro who essays to follow these instructions will probably not obtain satisfactory results the first time, but with practice and perseverance he will soon succeed.

Sulphate of ammonia, when quite pure, consists of two equivalents of ammonia (NH_3) combined with one equivalent of sulphuric acid (H_2SO_4), and its formula is usually written thus: $2(\text{NH}_3)\text{SO}_4$. This description is given in popular language, which plainly sets forth the actual facts; but is not quite in accordance with the latest scientific theories. Since the molecular weight of ammonia is 17, and that of sulphuric acid 98, it follows that the pure salt consists of 34 parts by weight of the former, combined with 98 of the latter; or reducing these proportions to percentages, we have in every 100 parts of sulphate 25.76 parts of ammonia, and 74.24 of sulphuric acid.

The process about to be described is based on the fact that, if a solution of ammonia sulphate is boiled with a fixed alkali, the ammonia is displaced, passes off with the steam, and may be collected in a condenser, or absorbed by acid. The apparatus required will be a retort stand and Bunsen burner, a 16-oz. flask, fitted with a sound cork, having two tubes passing through it. One of these tubes, which is long enough to reach nearly to the bottom of the flask, consists of a safety thistle-head funnel. The other tube, which passes only a sufficient distance through the cork to reach just into the body of the flask, is bent at right angles, a few inches above the cork, so as to follow a horizontal direction. The other end of it is again bent at right angles, so as to show downwards, and is connected, by means of a short piece of india rubber tubing, to a perpendicular tube of similar size, passing through a cork fitted in one of the necks of a three-necked Woulfe's bottle, and extending nearly to the bottom of the same. It should be noticed that the piece of india rubber tubing must only serve the purpose of a connecting piece. The ends of the tubes respectively must be cut off smoothly and rubbed down, so that they may touch and fit close together. If the hot vapors actually came in contact with the rubber tube they would soon soften it. One of the necks is closed by a plain cork, and the third has a cork bored to take the stem of a chloride of calcium tube, which is filled with small pieces of broken glass. This apparatus will be supplied by any philosophical instrument maker, or

can be readily made up from the instructions given in chemical handbooks.

The solution of sulphate to be tested is put into the distilling flask together with an excess of soda, and boiled. Steam and vapor of ammonia pass over into the Woulfe's bottle, and bubble through a solution of acid, the bottle having been charged with the same to a height sufficient to cover the end of the tube connected with the eduction tube from the distilling flask. Here the ammonia is absorbed, but to make sure that no ammonia is lost, the glass in the chloride of calcium tube has been moistened with acid, and therefore acts as a miniature scrubber.

We shall also require a set of two burettes, graduated to show 100 septems in 500 divisions, mounted on proper stands, as supplied with the same, two one-pint beakers, two pipettes to deliver respectively 100 and 50 septems, and glass stirring rods. Also a set of balances and weights. The chemicals will be solutions of soda, and of sulphuric acid, accurately prepared so as to contain in 1,000 septems ($\frac{1}{10}$ gallon) five times the atomic weight in grains. These are known as 5° solutions, and had better be obtained from the philosophical instrument maker, ready made. They will respectively contain $5 \times \frac{98}{2} = 245$ grains of sulphuric acid, and $5 \times 23 = 115$ grains of soda, per deci-gallon, or 0.245 grain, and 0.115 grain per septem; and they will exactly neutralize equal volumes of each other. A 5.0 solution of ammonia may also be provided, and this will contain $4 \times 17 = 85$ grains pure ammonia per deci-gallon, or 0.085 grain per septem. And lastly some tincture of litmus, of the best quality, will be required.

We are now ready to commence operations. Take a fair sample from the sulphate heap, which will best be secured by carefully mixing portions taken from all parts with a shovel. It must be remembered that the outside and upper portions will be drier than the interior and the bottom of the heap. A portion of about one ounce in weight should be transferred to a stoppered bottle and taken to the testing room. Carefully weigh out 50 grains, and dissolve it in about 2 ounces of distilled water. With regard to the latter, care must be taken that it is pure. The importance of using perfectly pure water in all analytical operations is such, that if it is intended to carry on a series of experiments, the best plan is to purchase a small still and condensing worm, which can be heated by a gas boiling burner, and prepare the same in the testing room. One or two gallons can be made at a time and stored in stoppered bottles. Another 50 grains of the sulphate may be weighed out and placed in a drying oven, carefully maintained at a temperature of 212°, for a few hours. The loss of weight will show the moisture present.

The apparatus having been built up as above described, a sufficient quantity of water is poured into the Woulfe's bottle. A small portion is also put into the distilling flask and caused to boil. This precaution will enable any leakage or faulty places in the corks to be ascertained, and also, by moistening the cork in the distilling flask, cause it to swell and become quite sound and tight. An excess of the standard sulphuric acid is then poured into the Woulfe's bottle, through the chloride of calcium tube, so as to leave the glass in the latter moistened with the acid. The quantity of acid that constitutes an excess may be arrived at as follows: We have seen that each septem of the acid is capable of neutralizing one septem of ammonia solution of equal strength, and it is therefore equivalent to 0.085 grain, or say, $\frac{1}{12}$ grain of ammonia. The 50 grains of sulphate will contain not more than 13 grains ammonia, and the quantity of acid required to neutralize this would be 156 septems. But as a decided excess must be used it will be best to put 200 septems in the Woulfe's bottle. This having been done, the solution containing the 50 grains of sulphate can be poured down the thistle-head funnel into the distilling flask (the gas burner having first been either extinguished or removed to avoid risk of cracking the flask). A quantity of standard soda solution, equal to the standard acid—viz., 200 septems—is also poured down, and a little distilled water is finally added to wash out the funnel. The liquid is then caused to boil slowly until about 3 ounces of water has distilled over into the Woulfe's bottle, which will occupy about an hour.

The apparatus is then disconnected, and the contents of the flask, and of the Woulfe's bottle, respectively poured out into separate beakers, the vessels being thoroughly rinsed out with distilled water, so as to be sure that the whole of the liquid is transferred to the beakers, the rinsings being, of course, added to the previous contents. Care must be taken to wash out the chloride of calcium tube so as to remove every trace of acid from it, the washing being added to the other contents of the bottle.

Taking the solution from the Woulfe's bottle first, we have here 200 septems of acid, partly neutralized by the ammonia contained in the sulphate. We know that the original 200 septems would require a similar quantity of either the soda or the ammonia solutions to neutralize it. If we now add the quantity of either of these alkalies that is necessary to produce that effect, the difference between the quantity required and 200 will give the quantity of acid neutralized by the ammonia distilled over. Accordingly the solution from the Woulfe's bottle is colored a distinct but faint red by the addition of a few drops (as little as possible) of the litmus tincture. One of the burettes is then filled with an alkaline solution, the ammonia being preferable. By

cautiously opening the pinchcock at the bottom the liquid is allowed to run out into a waste vessel until the surface stands exactly at the 100 septem mark. After waiting a minute or two to allow any liquid adhering to the sides of the tube to run down, the beaker is put beneath the burette, and the alkaline solution dropped in very cautiously until a purple tint appears. If an excess of alkali is added the liquid becomes a decided blue. Great care must be exercised to secure the exact point of neutralization—*i. e.*, when the liquid is neither red nor blue, but half way between, and if too much alkali is added it can be "brought back" by the addition of acid from the alkali burette, the quantity of acid used being carefully noted, and added to that already known to be present in the liquid. Suppose that 55.8 septems of the alkali are found to be required to produce this exact shade of neutralization. Call this *a*.

We now turn to the contents of the distilling flask. This originally consisted of 50 grains of sulphate, and 200 septems soda solution; but the ammonia of the former has been displaced, and the soda has taken its place. A quantity of soda corresponding to the acid in the sulphate has been neutralized, and this can be estimated by charging the other burette with the standard acid, and proceeding as above described. The only difference will be that the liquid will be blue instead of red, when tinged with the tincture of litmus. If the experiment has been accurately conducted, and the sulphate operated upon is neutral, the quantity of acid required should be the same as required by *a*. Let us call this *b*.

Sometimes, when the strength of the acid solution used in the manufacture of the sulphate is too high, the salt will give a distinctly acid reaction. Therefore, if it is found that *b* is higher than *a*, the 50 grains weighed out for drying may be dissolved in distilled water, and tested with blue litmus, which will be turned red if an excess of acid is present. If there is a decided excess of acid the solution can be colored with tincture of litmus, and titrated with the ammonia solution, in a manner similar to the acid solution in *a*, when the excess of acid can easily be defined. If the sulphate is found to be neutral, then it is probable that one of the solutions is incorrect, probably the ammonia, which is apt to lose strength by keeping. It is needless to add that all the solutions should be as fresh as possible, although if stored in a cool place, and in stoppered bottles of the best quality, they will keep for several months without alteration. When they are used care should be taken to return the stopper to the bottle as soon as possible; they should not be left open for any length of time.

We have now to make the calculation, which is a very simple one. We have seen from *a* that the ammonia present in the 50 grains of the sulphate was sufficient to neutralize $200 - 55.8 = 144.2$ septems of 5.0 acid; and from *b* that the acid in the sulphate was equivalent to $200 - 55.8 = 144.2$ septems of 5.0 alkali. Also that a 5.0 solution of sulphuric acid contains 0.245 grains of the pure acid per septem, and an ammonia solution of similar strength contains 0.085 grains of pure ammonia. Therefore

$$\begin{aligned} 144.2 \times 0.085 &= 12.257 \text{ grs.}, \text{ or } 24.514 \text{ per cent. of ammonia.} \\ 144.2 \times 0.245 &= 35.329 \text{ grs.}, \text{ or } 70.658 \text{ per cent. of sulphuric acid.} \\ \hline &47.586 \qquad \qquad \qquad 96.172 \text{ per cent.} \end{aligned}$$

So there is a residue of 4.828 per cent., which will be found to consist chiefly of moisture, and will also include dirt, dust, and accidental impurities.

An Ingenious Automatic Fire Kindling Device.

On the afternoon of Monday, Jan. 10, Mr. T. W. Campbell, of Vicksburg, Miss., made a public test in the city of New Orleans, La., of what he terms "an automatic heater and fire lighter," which device is the invention of his brother, Mr. Lowden Campbell, of Alexandria, Va. The trial was made in the engine house of Volunteer Steam Fire Company No. 1, located on Hunter street, and the result answered in every way the claims of the exhibitor. Our report of the affair is rather incomplete, owing to our informant having neglected to furnish dimensions of pipe, quantity of gas consumed, etc.; but perhaps the following will furnish a measurably understandable description of the device and its operation.

The contrivance is so arranged that by means of a gas pipe inserted through the ordinary fire door of the engine a degree of heat sufficient to keep the standing water in the boilers at a fair warmth is maintained. A gas lamp or burner equipped with a stopcock, from which project two arms like two spokes of a wheel, is fastened to the floor. A small bar is screwed to the bottom of the boiler, and as the engine passes over the lamp the bar strikes one of the spokes and turns on the gas. A jet of flame about a foot in height spurts upward, and as the boiler of the engine passes over the flame the fuel in the fire-box, previously saturated with inflammable oil—in his test Mr. Campbell used coke saturated with kerosene—takes fire. A second bar on the rear part of the boiler strikes the second of the aforementioned spokes, which latter is raised by the depression of the first, and the gas supply is cut off. The gas pipe, previously spoken of as being inserted under the boiler to keep the water warm while the engine awaited the

signal of the firemen, drops out as the engine moves forward, and, by its weight, drops to the floor and cuts off the gas in the socket or elbow. Our informant, who was present at the trial test, says that the device is very ingenious and exceedingly simple. He is of the opinion that in its use much valuable time can be gained, as the steam fire engine so arranged in its house could raise sufficient steam, within $1\frac{1}{2}$ minutes from the time of starting to a fire from its resting place, to force water through the hose. The apparatus has other merits—cheapness and ease of application.

SPECIAL ENGLISH CORRESPONDENCE.

COMMUNICATED BY NORTON H. HUMPHREYS.

SALISBURY, Jan. 10, 1887.

Gas as a Domestic Servant.—Smokeless Fires.—Mr. Lewis T. Wright on "Liquid Fuel."—Annual Reviews.—Young's Ammonia Purification Process.

Some interesting information as to the uses of gas for heating and cooking has recently appeared in the pages of a Glasgow paper. Here is an eloquent description from the user of a gas fire for three years. "This morning is very cold; flakes of snow are flying; the roofs of the houses are white with hoar frost, and here am I, at 7 A.M., seated in my room, 12 feet by 13 feet, in a warm, comfortable atmosphere. I put a light to my fire when I got out of bed ten minutes ago, and the room is already in a habitable state. No breaking of sticks, no carrying of coal, no raking out of ashes, no raising of dust, no dirtying of the room—only the application of a match and all is serene. The fire burns for an hour, my specified time for writing in the morning, and the cost is about three-fourths of a cent. When 8 o'clock strikes I turn off the gas and go to breakfast. I leave my warm room in the state in which I found it—free from dust, free from a dying-out fire and its attendant ashes and cleaning up. When I turn off the gas the expense ceases, and without the gas my hour's work in the morning would be lost." This letter is an excellent testimonial as to the uses of a gas fire for business men, many of whom find it convenient to have a small sanetnm or study at home for letter writing, etc. The hour before breakfast in the morning is of great importance to many, and the convenience of the gas fire in the study is such as to far outweigh any consideration as to cost of gas. In my own library a gas fire is fitted up, also a Chubb's lock on the door. The gas fire dispenses with the almost daily visit for dusting, and that is almost indispensable when a coal fire is used, besides the lighting of the fire, bringing in coals, etc. I light the gas fire, when necessary, when coming in, and turn it out on leaving, take the key with me and go away, leaving desks, drawers, etc., open, papers and books laying about all ready for use, knowing that they are quite safe from the investigating fingers of my wi—of the servants and children, I mean.

Another correspondent gives the results of a year's working without coal, using gas for heating and cooking purposes. As a result he was able to economize in the item of domestic help, and he estimated the saving by using gas stoves at no less than \$100 per annum. The great disadvantage in the introduction of gas stoves into houses is that they usually have to be adapted to flues originally designed for coal fires, and, therefore, unsuitable for them. It would be interesting to know the results of using gas for all household purposes, by means of appliances fitted with flues designed specially for the stoves, so as to secure sufficient ventilation with the least possible loss of heat. One of the chief difficulties in the way of the introduction of gas stoves is the fact that the chimney is usually the only means of ventilation, and when this is practically blocked with a view of adjusting the draught to the requirements of the stove the lack of ventilation becomes apparent, and the stuffy atmosphere is said to be due to the gas.

The chimney sweep is by no means a desirable visitor in the domestic circle. The work of sweeping the chimney and removing the soot entails a vast amount of preparatory moving about and subsequent cleaning up. I have heard of one instance in which a sweep caused great consternation. A party of sporting gentlemen were sitting up late on a Sunday evening, playing cards, and continued their play until nearly daylight. The sweep had been told to call very early on Monday, and accordingly proceeded to the house. Seeing a bright light in the parlors, and a French window left open, his "sooty majesty" concluded that the servant had already prepared for him, and going up to the window called out, "Are you ready for me?" The sight of his black face was enough for the obfuscated gamblers, who fled in all directions. In any case, the periodical visits of the sweep cause so much dirt and trouble that most people would be glad, like Prof. Frankland, to go for five years without having a chimney swept in the house. The Professor has accomplished this by very simple means. No new grates or stoves have been put in, the ordinary grates fitted in when the house was built being still in use. The only alteration, or rather addition, was a movable blower, costing about 50 cents, for each grate; and gas coke was ordered to be used instead of coal. The use of the blower enables the fire to be lighted in the

ordinary way. Prof. Frankland frightens the London people now and then by telling them of the awful things, with long Latin names, that exist in the water they drink, and he has now rendered them a most important service by showing that a sure cure for the smoke nuisance, which has become so very prominent in London, is available to every householder, without trouble and without expense.

Mr. Lewis T. Wright, the General Manager of the Nottingham Corporation Gas Department, has contributed to the proceedings of the Society of Chemical Industry an important paper on "Liquid Fuel."* It comprises an account of some experiments on heating boilers with tar, coal, coke, and creosote respectively. While with coal only about 70 per cent. of the theoretical heating value was realized in practice, 80 per cent. was obtained from the coke, and 84½ per cent. from the tar. Mr. Wright gives the composition of his tar as 80 per cent. carbon, 7 per cent. hydrogen, and the remainder consists chiefly of oxygen. It must be remembered that the constitution of tar varies according to the manner in which it is prepared. I have often heard tar distillers say that the tar from small works is much the best for their purposes. The fact is, that as a rule the small works cannot run such high distilling temperatures and short charges as the large ones, and consequently the tar, being produced at a lower temperature, is much richer as regards the lighter oils, and these contribute principally the hydrogen that is present. The practical heating value of hydrogen is some three times greater than that of carbon, and consequently even a very small difference in the quantity of hydrogen present will have a considerable influence on the heating value of the tar. But the most interesting feature of Mr. Wright's paper (to gas engineers) is a new design for a retort house tar furnace which evidently produces excellent results, and is a great improvement on the methods of tar burning now in use. Both the tar and the air supply are distributed without the use of steam so effectively that the furnace works without producing smoke, even when the air supply is reduced to nearly the theoretical quantity, in this respect comparing favorably with the best gas furnaces. The arrangement can be readily adapted to any ordinary coke fire, and taken away again if desired. Indeed this could be done without letting down the heats. Mr. Wright's arrangement is one of the most important improvements which the modern reign of tar burning has had the effect of bringing out.

At this season of the year all the technical magazines have as an important feature a review of the year now closed, together with some anticipations as to that which has just dawned upon us. The general tone, with respect to the gas industry, is one of great satisfaction. Perhaps rather too much importance is attached to the decline in the price of tar and ammonia, which is not altogether an unmixed evil. It would be very pleasant to have a regular demand for tar at 45s. per ton, and sulphate at £20, but it is hopeless to expect such. Even if the market was firm at such prices for a time, it would soon be upset by large supplies from coke ovens, blast furnaces, and works specially erected for the utilization of colliery waste, etc. I would rather see the gas industry standing on its own bottom than bolstered up by large receipts for residuals. As regards the main points, such as the prices of materials, and the demand for gas, both have been satisfactory. Coal and iron have been obtainable at moderate prices, and if the consumption of gas has not increased to the extent that has been experienced in previous years, it certainly has not gone back. It is worth while to notice the significant fact that gas securities of all kinds have improved in value during the year. Notwithstanding the high prices at which they stood at the end of 1885, their value was still higher at the end of 1886.

Mr. William Young, of Clippens, has just patented a process for the complete purification of coal gas by means of ammonia obtained from the ammoniacal liquor. He proposes to bring the crude gas in contact with caustic ammonia solution, the said solution being obtained by submitting ordinary liquor to a temperature under 212°, by which the impurities are driven off, leaving the ammonia behind. The most important feature is the conducting of this dissociating process at a pressure of 50 lbs. per square inch or so. Mr. Young has discovered that these conditions of pressure do not interfere with the dissociation, nor do they materially increase the solubility of the acid gases; but the solvent power of the water on the ammonia is greatly enhanced. Consequently much stronger liquors can be treated by this process than could possibly be done by those previously known, which treat the liquor at atmospheric pressure. Hitherto the usual plan has been to cause the ammonia solution to travel in the opposite direction to the gas. He describes a simple arrangement for carrying out his invention, consisting essentially of a dissociating vessel, a concentrating still, an ammonia scrubber, and a water scrubber. The first two consist of cylindrical towers, and the scrubbers are narrow rectangular vessels containing a number of troughs superimposed one on the other. A boiler for generating steam, and a small engine for working two pumps are required, and the engine may be worked by the gases escaping under pressure from the dissociating tower, thus econo-

mizing steam. The office of the pumps is to raise ammoniacal liquor from a reservoir tank at the bottom of the ammonia scrubber to the top of the dissociating tower; and from the base of the still to the top of the ammonia scrubber. The cycle of operations is as follows: Crude ammoniacal liquor from the store well is supplied to the top of the dissociating tower, by means of a connection attached to the pump. After passing down through the specially devised scrubbing arrangement, it accumulates in a reservoir at the base, which is surrounded by a steam jacket. Here it is heated, and the dissociation takes place, the desired degree of pressure being obtained by means of a loaded escape valve. This vessel must, of course, be strong enough to withstand the pressure, and it is fitted to a safety valve. As soon as the liquor is sufficiently caustic it is passed on through an ingeniously devised trap, which prevents loss of steam, to the concentrating still, where it is heated by a current of steam. From this it is caused to pass through a water condenser on the top of the ammonia scrubber, and then into that vessel. As soon as this is properly charged the crude gas may be admitted, and passing repeatedly in contact with the liquor, parts with its carbonic acid and sulphuretted hydrogen. The process is continuous, caustic liquor being supplied to the top of the scrubber, and the spent liquor being drawn off to the dissociating tower, the rate of treatment of the liquor being regulated to keep pace with the quantity of gas to be purified. Several ingenious arrangements in detail enable the whole to be under control. The water scrubber serves to remove any excess of ammonia that may remain with the gas. It is supplied with clean water, and the liquor accumulating in it is either treated for the recovery of the ammonia it contains, or passed on to the dissociating tower. I hope to refer further to this ingenious and carefully worked out system of apparatus on a future occasion.

ITEMS OF INTEREST FROM VARIOUS LOCALITIES.

ANNUAL ELECTION.—At the annual meeting of the stockholders of the Whitehall (N. Y.) Gas Light Company Mr. F. A. Sabbaton, of Troy, N. Y., was elected President; W. F. Bascom, Treasurer; and H. A. Brooks, Secretary.

ELECTION OF TRUSTEES.—At a meeting of the stockholders of the Consolidated Gas Company, of this city, held Jan. 24, the following-named gentlemen were elected to serve as Trustees for the ensuing year: Gen. Charles Roome and Messrs. T. K. Lees, O. Zollikoffer, C. G. Francklyn, T. Rutter, H. E. Gawtreay, P. R. Pyne, S. Sloan, J. W. Smith, H. Day, J. P. Huggins, E. S. Higgins, and H. Clauson. From the foregoing it will be seen that no change was made in the Board, the list being identical with that reported after the election of Jan. 25, 1886.

A WAIF FROM WILMINGTON.—Mr. Thos. Curley, who for so many years has safely piloted the Wilmington (Del.) Gas Company on and over the tides of business, writes us that the new net rate, which became operative on first of year, gives great satisfaction to the gas consumers. Under the new schedule gas is supplied at \$1.35 per thousand, and nearly 500 gas stoves of all sorts are in use in the city. Despite the competition with the local electric lighting company, the gas output shows an increase over the quantities sent out prior to the advent of the electricians. The holders of Wilmington gas shares ought to be satisfied with the management of President Richardson and Superintendent Curley, for they receive an annual dividend of 12 per cent., and the stock is worth double the nominal par value. However, the Wilmington gas proprietors own much valuable property that was paid for out of the earnings of the Company, and therefore not represented in the nominal capital. Mr. Curley says (his letter bears date of Jan. 20) his Company is putting in "a small water gas plant (Flannery system) as an auxiliary to our coal gas apparatus." We are glad to be able to say that Mr. Curley has entirely recovered from the illness that beset him about a month ago.

SOMETHING FROM TYRONE, PA.—At the January meeting of the Tyrone Common Council Mr. C. H. Dieffenbach, acting for the Tyrone Gas and Water Company, handed in a proposition to light, extinguish, keep in repair, furnish all gas, gasoline, and oil needed to keep in duty 34 gas and 21 oil or gasoline lamps for the sum of \$900 per annum, payable in twelve installments. The lamps are to be lighted "until 12 o'clock of each night in the dark phases of the moon." The proposition was laid over to be discussed at the meeting of Council to be held on the 7th inst. Perhaps by that time the Tyrone gas folks will not be disposed to offer such favorable terms. In the meantime the local electrical promoters have started up their plant—the dynamos were put in motion on New Year's night—and the initial attempt was rather disheartening. Interruptions were frequent, and gloom was the result. Now, however, they have things in somewhat better shape, although it seems needless to add that eccentricities in the supply are far from being in line with "angels' visits." The electricians had counted upon \$8,000 as sufficient for their needs; but when all the items were footed up it seems that \$14,000 had been invested. On at least three-fifths of that sum they

**Ante*, p. 67.

are paying 6 per cent. per annum, and as the number of lamps now in circuit totals up to 800, and which are furnished at a monthly charge of 50 cents per lamp, it is hard to figure out where the Tyrone electricians can expect to make a dividend in the twelvemonth. There are, however, dividends of various sorts; for instance, that denominated as an "Irish dividend," so called because it requires those interested in an enterprise to draw a check, payable to the managers of the particular enterprise, the proceeds of which are intended to make good a deficit caused by inability of those in charge to make the receipts meet the expenses.

A LINE OR TWO FROM BRO. STEIN.—In a letter from Mr. Edward Stein, of the Siemens-Lungren Company, of Phila., Pa., written in Paris, France, and bearing date of Jan. 9, that astute gentleman says: "Paris very beautifully lighted, and entirely with gas. I am greatly surprised at the small number of arc lights in use in Great Britain and France; and in fact I believe there are a larger number of arc lights on Broadway, say between the Astor House and the Fifth Avenue Hotel, than can be found in all of Great Britain and France. Indeed, if you set out to find an arc electric light in either of these countries you would be obliged to do considerable searching. I have visited a number of manufacturers of gas appliances, and find them all more or less busy in their various lines. Gas companies here seem more active in the matter of introducing appliances than is the case in the States, and I note that great attention is devoted to the question of cooking by gas." Mr. Stein expected to start for home on the 22d of January, presumably by the steamship *Aurania*, which left Liverpool on that date.

ALTOONA (PA.) HAS THE ELECTRIC LIGHT.—And has it with a vengeance, too. The Edison incandescent system of supply was started up in that city sometime in the first week of January, and now another lot of promoters seek to have the Councilmen grant a charter for an opposition, or an independent, electric company. If these latter obtain the desired permission there ought to be lively times in the artificial lighting business of Altoona. If we mistake not the Altoona Gas Company charges a net rate of \$1.50 per thousand cubic feet.

AN ANSWER TO SEVERAL INQUIRERS.—Those who have written to us in regard to particulars concerning the position now held by Col. W. A. Stedman, are hereby informed that the Colonel is now acting as Secretary and Treasurer of the American Electric Manufacturing Company, and his office is at No. 146 Broadway, this city. He is connected with the Newport (R. I.) Gas Light Company in the capacity of consulting engineer, nominally; but we incline to the idea that he is still and will remain closely identified with the Company that owes so much to his talent and sagacity.

ANNUAL ELECTION, DANVERS (MASS.) GAS COMPANY.—At the annual meeting of the Danvers Gas Light Company, held Jan. 13th, Messrs. G. A. Tapley, M. L. Merriam, C. S. Purinton, L. A. Wyman, and W. E. Fette were chosen to compose the board of directors. Mr. Louis Malm was elected Clerk and Treasurer. The directors, at a subsequent meeting for organization, elected Mr. W. Eliot Fette to the dual position of President and Agent of the Company.

NO CONSOLIDATION INTENDED.—Some time since rumor asserted that the Boston Brush Electric Light and the Boston Gas Companies were to be combined under the Presidency of Mr. M. S. Greenough, with Mayor Hugh O'Brien as Treasurer, who now holds a similar position in the Boston branch of the Brush Company. The alliance was said to have been completed, but investigation proved that there was no truth in the assertion.

NAMED AS WESTERN AGENT.—Mr. C. L. Gerould, of the Nassau Gas Light Company, of Brooklyn, N. Y., informs us that Mr. H. T. Gerould, of Mendota, Ills., will hereafter act as Western agent for the sale of "Gerould's Improved Retort Cement."

CHOSEN FOR THE PRESIDENCY.—Mr. E. S. Atwater has been selected by the stockholders of the Poughkeepsie (N. Y.) Gas Light Company to assume the duties attached to the Presidency of that Company. It will be remembered that Mr. Atwater succeeds the late Mr. E. M. Van Kleeck, whose death was reported in our last issue.

TO EXTEND A CHARTER.—A bill to extend the charter of the Portland (Me.) Gas Light Company asks that that instrument be extended for a period covering 30 years beyond the period of limitation now fixed by the law. It is probable such consent will be granted.

ANNUAL ELECTION.—At the annual stockholders' meeting of the Capital Gas and Electric Light Company, of Frankfort, Ky., the following officers were elected: President, Gen. D. W. Lindsey; Secretary and Treasurer, E. L. Samuel; Superintendent, S. J. Shea; Directors: Gen. D. W. Lindsey, and Messrs. E. L. Samuel, J. W. Prewitt, P. McDonald, and W. O. Herndon.

ANNUAL ELECTION AT NEWPORT.—The board of officers elected for the ensuing year by the stockholders of the Newport (R. I.) Gas Light Company is as follows: President, H. Bull; Secretary, J. H. Cozzens; Treasurer, A. K. Quinn; Supt., W. B. Knight; Directors: H. Bull, J. H. Cozzens, J. A. C. Stacey, P. Rider, J. A. Peckham, Robt. Chace, and W. H. Fludder. As stated above, Col. W. A. Stedman will act in the capacity of consulting engineer for the Company. The directors were authorized to establish an electric lighting plant.

BROTHER ROLLINS STILL AT WORK.—The thoroughgoing Agent and Superintendent of the Worcester (Mass.) Gas Light Company intends to amuse himself this summer by following out a varied programme, arranged in something like the following: The Company's Lincoln Square holder (capacity 62,000 cubic feet) is to be rebuilt, and a new or additional holder (calculated for a capacity of 400,000 cubic feet) will be erected at the works. The latter holder will be enclosed by a brick house topped with a slate roof. A new 20-inch main is to be led off from the large holder for a distance of, say, 2,500 feet, and other proposed conduit enlargements and extensions embrace the placing of over two miles of pipe, with diameters ranging between 16 and 4 inches. New covers are to be placed on the purifying boxes (16 ft. by 32 ft.), and new cups are to be fitted in the 24-inch seal. Now, putting these things together, Brother Rollins won't have much leisure to devote to the consumption of "shore dinners," etc., when the season of such festivities comes to hand; but Rollins, being comfortably equipped in the matter of solid avoirdupois, will probably not find himself badly "reduced" even should he omit an occasional outing. Last year the Worcester Company manufactured 85,739,500 cubic feet of gas; the annual sendout was just 10,000 cubic feet less, and the ledgers show that 79,272,500 cubic feet were sold in the twelvemonth. The candle power, as shown by the tests made at the works, averaged 18.4 for the year. The Massachusetts State Gas Commissioners, early in January, notified the Worcester Gas Company that as complaint had been formally made against it by residents of the city, who asserted that the gas supplied them was of poor lighting value, impure in quality, and that an excessive rate was charged, the Company must appear before the Board to answer the accusations, and properly defend itself. The accused retained Messrs. R. M. Morse and Col. G. A. Bullock as counsel, and the hearing was set for January 26th. At present time of writing we have not heard how the case was decided; but we may here briefly cite how the complaint originated. Worcester was recently blessed with an addition to its newspaper guild, in the shape of a daily, called the *Telegram*. The editor, of course, attacked the local gas suppliers, and finally became so enthusiastic on the subject that he actually imagined he was a better gas meter than the one maintained on his premises by the Worcester gas folks. At any rate, the scribe asserted that one particular bill rendered was too high, that he would not pay it, but sent a check to the Company for what he thought was about right. Agent Rollins deposited the check, and promptly notified the "former of public opinion" that he still owed a balance on his account—the balance was about \$34—non-payment of which within a certain time would cause his gas to be shut off. The scribe "came down" under protest, and then indited an editorial asking for signers to a petition praying the Gas Commission to investigate the affair and the Worcester Gas Company. By hook or crook he managed to obtain the desired number of signatures, and so the authorities stepped in. Although the whole thing looks like a veritable teapot tempest, it nevertheless will be followed with interest as showing what sort of metal is in the Massachusetts Commissioners, and the kind of treatment gas men are likely to receive at the hands of such bodies. This, we believe, is the first case in which the judicial portion of the Massachusetts Commissioners' power has been invoked, and we expect to give a comprehensive report of the proceedings with our next issue.

THE BOUTON FOUNDRY COMPANY.—Mr. Carl D. Bradley, who is well known to the fraternity from his former connection with the Union Foundry, etc., of Chicago, Ills., has been made Secretary of the Bouton Foundry Company, located at Nos. 2600 to 2626 Archer avenue, Chicago, Ills. The other associates in the new enterprise are Messrs. N. S. Bouton, E. G. Shumway, and F. W. Barker. The Bouton Foundry proprietors are to make a specialty of iron work for gas plants, and can be depended upon as reliable and efficient. It might here be said that Mr. Bradley severed his connection with the Union Foundry on the first of the year.

PARTIAL DESTRUCTION OF A GAS WORKS.—The new plant at Spencer (Mass.) was to have been ready for gas making on Jan. 13th, and that expectation may have been realized for all we know; but it is beyond doubt that no gas is being made there now, for the works were partially destroyed by an explosion which occurred in them on the afternoon of January 20th. The loss is reported at \$6,000. Our details of the affair are far from complete, but as near as we can judge the buildings suffered most, although the machinery must have been pretty badly wrenched. The holder sustained no damage.

TO TAKE CHARGE AT MARLBORO', MASS.—Mr. Wm. A. Anderson, who has been in the service of the Chelsea (Mass.) Gas Light Company for the past 16 years, took charge of the Marlboro' works on the 1st inst. We don't exactly see how Brother Andrew can fail to miss the services of one who stood by him so faithfully, and we are at a loss to comprehend how Mr. Anderson will be content in his new quarters without an occasional bout with his old-time friend and director at Chelsea. All speculation laid aside, however, we congratulate the Marlboro' folks on their luck in securing such a Superintendent, and hope that Mr. Anderson, who has taken a forward stride, will soon be ready to mount higher.

A WORD FROM DALLAS, TEXAS.—We are in receipt of the following interesting letter from Mr. Wm. Enfield, Superintendent of the Dallas City Gas Light Company. It bears date of Jan. 15. "I am kept very busy, as you may guess when I state that the Company's business has increased fully 50 per cent. within the last year. Our people are not disposed to be loud in their methods of doing business, nor do they seek display. They prefer to move on quietly, but not the less effectively. The local electric lighting company, with which I had been in conflict last summer, has put on new life and energy in the shape of a new directorate and management. The owners of the gas company were given to understand through a middleman, shortly before the 'change of life' was experienced, that the electric light plant could be purchased, and that if not so purchased the plant would be placed under more aggressive management, and pushed with far greater vigor than was the case in the past. I told said middleman (who, by the way, hails from Chicago, and claims to be agent for a water gas system that beats the world, but whose virtues he neither could describe nor figure out) that the owners of the gas company understood my views as to the operation of electric lighting plants by gas companies, and subsequently introduced him to the 'powers that be,' from whom he seems to have departed to stir up the promised aggressive warfare. The electric lighting system here consists of both arc and incandescent, the lamps being a Chicago product, and can be guaranteed to light, or not to light, according to circumstances—but the circumstances cannot be guaranteed. We feel pretty well and lively, thank you; and, though not seeking the fight, feel in condition for a vigorous defence. Dallas, as you may have heard, is growing very rapidly, and is now the best city in the Lone Star State. In addition to attending to the details of a business of an almost abnormal growth, I have had my hands full this last season in enlarging the works. A line of 12-inch main pipe, and a line of 8-inch pipe branching from it, with many smaller mains in the outlying districts; a 12-inch Connelly automatic governor; a 78" x 78" station meter; new pipes and connections throughout, making the plant an 8-inch one; a new regenerative furnace and setting of fives in an old arch; and last, but not least, tearing out a stack of 3 benches of threes and replacing them with a new stack of three benches of sixes, fired with the regenerative furnaces, were the much-needed improvements which I perfected successfully and without accident, and now have working to our entire satisfaction. One of the chief drawbacks to my labor has been the almost utter impossibility to secure skilled labor worth anything at all; and to mend matters I had a strike for the 8-hour-and-same-pay movement to start in on, when every man (lamplighters included) except the foreman left the works. This spring we build a new holder—sadly needed, too—of 110,000 cu. ft. capacity, the Kerr Murray Manufacturing Company having been awarded the contract. Dallas has every indication of a continued boom—which reminds me that I have no more time to spare, even if you could afford to peruse the uninteresting matter I might write." Mr. Enfield "might" write uninteresting matter; but since one must judge of what is to come by looking over that which we see, only one verdict is permissible from the inspection so made, in this case at least—and we think our readers will concur in the decision—for we decide that "interesting" has it by a large majority.

PAYING THE PIPER.—When the project for lighting the streets of Troy (N. Y.) by electricity was first discussed it was estimated that 100 arcs would be sufficient for the purpose. At the present time about 250 arcs have been placed in position, and the end is not yet, notwithstanding the fact that the sum of \$60,000 is now annually paid for the street lighting service. When gas was used exclusively the taxpayers were called upon to contribute but \$24,000 per annum. Luxuries must be paid for, and the Trojans are paying a pretty penny for whatever luxury is extracted by them from between the carbon points.

PERSONAL.—Mr. K. M. Mitchell, who formerly occupied the position of Superintendent to the St. Joseph (Mo.) Gas and Manufacturing Company, was presented by the employees of the latter Company with an elegant office chair when he resigned the berth above noted. Mr. Mitchell, as we are informed, is now in the service of the St. Louis (Mo.) Gas Trust. Mr. John H. Fitzgerald, of Park City, Utah Terr., assumed charge at St. Joseph, and we might explain that he is very well and favorably known by the Western

fraternity, chiefly through his former business connections with the Kerr-Murray Manufacturing Company, of Fort Wayne, Ind.

BEGINNING THE "AGGRESSIVE WARFARE."—Since the receipt of Mr. Enfield's letter, which appears elsewhere in our item columns, we understand that the Dallas City (Texas) electricians have started the "aggressive warfare," threatened by them in case the owners of the Dallas City Gas Light Company did not buy out the electric plant, in the usual style—i. e., they have trained their guns on the Council Board, and appear to have struck the target. We think so, at least from the fact that Alderman Carter succeeded in securing the passage of a resolution which directs the Mayor to appoint a committee of three "whose duty it shall be to inquire into the feasibility of lighting the city with electric light, and to correspond with the different manufacturers of electric plant in regard to the cost, etc., of the same." Also to obtain any other information they can secure in reference to the subject, and to report the same to the Council at as early a date as possible. Messrs. Carter, Loeb and Brown were named on the committee.

DENIED A CHARTER.—Last Spring a combination of Pittsburgh and Philadelphia capitalists applied for a charter which would secure to the applicants an exclusive right to furnish fuel gas in the city of Philadelphia. It was proposed to operate under the name of the Hydrocarbon Gas Fuel Company, and the articles placed the initial capitalization at \$1,500. The scheme no doubt was intended as the entering wedge of a goodly-sized grab of one sort or another, and considerable opposition was aroused. This culminated in the employment of counsel by the protesters, who were instructed to make argument before the Attorney-General, at Harrisburg, against the proposed grant. Messrs. Leaming and Wintersteen presented the remonstrants' side of the case, and argued so effectively that the Attorney-General decided adversely to the petition of the applicants. It is understood that this was regarded as a test case, for many similar applications, for other districts of the State, were pending. We have not received the text of the decision, but understand that the unfavorable ruling largely depended upon the "exclusive rights" portion of the conditions sought to be attained.

ANNUAL ELECTION.—At the annual meeting of the Williamsport (Pa.) Gas Light Company the following officers were elected: President, Hon. J. M. Gazzam; Sec., Treas., and Supt., Mr. C. A. Byers; Directors: J. M. Gazzam, R. P. Allen, J. G. Reading, B. C. Bowman, J. B. Coryell, H. Mudge, and J. G. Reading, Jr.

AN ACKNOWLEDGMENT.—We are in receipt of copies of the American Meter Company's Pocket Almanac for 1887; also the Helme & McIlhenny Lighting Calendar for current year. These "annuals" are handsomely gotten up, and contain much of practical value for superintendents and engineers. We return thanks for the copies sent us. In passing, we may note that the annual issued by Sugg & Company, of England, resembles the American Meter Company's book closely enough in some respects to suggest the idea that Mr. Sugg's compiler had previously examined a copy of the "data sheets" so long a valuable feature of the American Meter Company's book. If we mistake not, Mr. Wm. H. Down originated the idea, and ought to get proper credit for it.

THE YONKERS (N. Y.) GAS WAR.—It is understood that the gas war which lasted for such a length of time in Yonkers has terminated. The details of the truce are unknown to us, but Mr. Cornell, of the old Yonkers Company, is not the sort of man to conclude an armistice without having had a great deal to do with the framing of its provisions.

MORE PAY FOR OTHER PIPERS.—According to the Hannibal (Mo.) *Evening Post*, the electric plant owned by the city has been in operation but little over six months, and yet the items chargeable to repair account alone in that period foot up to about \$2,000. Better get rid of the electrical annex to the city department, and so allow private enterprise to bear the brunt of the burden.

ELECTRIC LIGHTING AT RAHWAY, N. J.—Last year the Tesla Electric Light and Manufacturing Company was granted a contract for lighting the streets of Rahway, and the system has thus far proved a complete failure. In fact, so wretchedly poor has been the service that a resolution has been passed by the Council directing the Committee on Lamps to wait upon the Gas Company in order to see what arrangements could be made with the latter for lighting the city until June next. The reference, however, cannot be expected to accomplish much in the premises, or in respect of working an abrogation of the Tesla contract, for when the *JOURNAL* noted the award of the Tesla contract (see issue for July 2, 1886, page 12), we had occasion to write—in speaking of the impartiality (?) of the Rahway Lamp Committee—the following: "The Committee consists of three members, and of these two own the building which houses the Tesla plant, while the remaining 'impartial' is a member of the Tesla Company."

CAPITAL INCREASED.—The American Gas Company, of Philadelphia, Pa., has increased its capital stock to \$500,000.

A FEW FIGURES FROM THE REPORT.—The Second Annual Report of the Massachusetts Gas Commission has been presented to the Legislature. We have not yet received a copy of the document, but the following figures and facts taken from the *Boston Journal* are presumably authoritative: Sixty-three companies now do business in the State; of these 61 made returns in compliance with the request of the Commissioners; 2 companies were organized under the general law during the year. The capitalization runs from \$2,948 to \$25,000 a mile of main; from \$2.19 to \$24.78 a thousand feet of gas sold; and from \$22.56 to \$150 a ton of coal carbonized. The companies received during the year, from all sources, \$4,391,823.50, and of that \$3,590,669.42 was for 2,091,210,980 cu. ft. of gas sold by meter. For gas supplied to public lamps \$432,085.90 was received, and \$341,020.76 for residual products. The total expenses were \$2,896,745.92, leaving an apparent profit of \$1,495,077.58. Interest, rent, etc., brought the profit up to \$1,548,456.59. Dividends, interest, and other items paid amounted to \$1,024,768.81, leaving a surplus of \$523,687.78. Two of the companies failed to earn expenses, and seven others have not earned sufficient to warrant a dividend. The balance sheets from all but two companies show aggregate assets of \$14,660,958.90, and a surplus of \$1,801,967.09. The valuation of all the works assessed for local taxation was \$12,188,868. The total taxes paid were \$220,948.23—an average of 9.4 cents a thousand cubic feet of gas sold. There are now 40 electric light companies in active operation, with an aggregate capital of \$3,500,000, and a capacity of about 5,500 arc and 30,000 incandescent lights." When we shall have received copies of the report we will refer to the statistics again.

MR. HINMAN'S ANNUAL REPORT.—Mr. Chas. W. Hinman, Inspector of Gas and Gas Meters for the State of Massachusetts, has handed in his annual report. From it we learn that during the year 10,604 meters were inspected. Of these 10,480 were either new or had just been repaired, and consequently were correct. The remaining 124, which had been in use and whose correctness was doubted, were reinspected, with the following results: 38 were fast, averaging 4.55 per cent. from correct; 64 were within the legal limit of 2 per cent. either way; and 22 were slow, averaging 12.43 per cent. from correct. The Inspector states that the inspections of the last 15 years show that although the number of gas consumers has greatly increased, the number of meters complained of has decreased about one-half. The proportion of fast to correct meters is about the same, however long the meters have been in use; and of slow meters to correct ones nearly twice as great as the general average, when the meters have been in use a long time. The general results of his tests, says the inspector, prove that the meters are no faster than they ought to be. The report contains much statistical matter in regard to the illuminating power of the gas furnished by the different companies, etc.

A PROPOSED TAX ON GAS SUPPLY IN VIRGINIA CITY, NEV.—Those in authority in the premises propose the passage of the following ordinance: "Every person, firm, association, or corporation engaged in the business of delivering or supplying gas to customers through gas pipes laid through and under the streets within the limits of the city of Virginia, shall pay quarterly for a license to conduct such business according to his, their or its average monthly receipts or sales, as in the following schedule: *First Class*—Monthly receipts or sales \$4,000 or over, quarterly license, \$100. *Second Class*—Monthly receipts or sales under \$4,000 and over \$2,000, quarterly license, \$60. *Third Class*—Monthly receipts or sales under \$2,000, quarterly license, \$25."

MR. J. L. HALLETT TO SUCCEED THE LATE MR. MERRICK.—The annual meeting of the Springfield (Mass.) Gas Light Company was held on January 24th. Messrs. Chapin, Gunn, Rumrill, Lee, Porter, Hallett, and Hale were chosen directors. Mr. J. L. Hallett was made Treasurer, vice Mr. Wm. Merrick, deceased.

A Portable Coke Stove.

Messrs. E. Raffel & Co., of Copenhagen, have brought out an improved portable stove, and although the dimensions of same are comparatively small—the height of the stove being only three feet six inches, with a diameter of fourteen inches—it possesses a considerable heating capacity, coupled with great economy in fuel, the consumption being something less than two lbs. of coke per hour when in full operation. The stove completely consumes its own smoke, and will burn incessantly, night and day, for several months, the grate being so constructed that it can be easily cleaned and the stove refilled. The apparatus may be placed wherever an outlet can be obtained for the products of combustion, and, as the stove is fitted with wheels, it can be taken from one room to another, when required, and placed in front of the fireplace. The construction is very neat, and the external appearance does

not suffer by use, as the inner stove containing the fire is surrounded by a cylinder of plate iron, the atmospheric air passing between the two. A vaporizing pan is fixed on the top of the stove for moistening the atmosphere, and the temperature is controlled by a ventilator fitted in the door. This stove has in comparatively little time met with a large sale, and several thousand are already in use, especially in Denmark and Sweden.

Annual Meeting of the Brookline Gas Company.

The Brookline (Mass.) Gas Company held its annual meeting on January 19th. The report of the President alluded to the successful operation of the Suburban Light and Power Company, in Brighton and Allston, and of the future possibilities of the same as a source of income. The shares of this latter Company can be purchased at any time at par by the Brookline Gas Company. A petition is now before the Legislature to extend the charter of the Brookline Company to include electric lighting, and it is believed that there is no opposition to it. A dividend of six per cent. has been declared the past year, and the profit and loss account shows a credit of \$18,483. The Company has 50 miles of pipe now in the streets, and in a growing district. The price of gas was reduced in April to \$2.20, and another reduction is looked for soon. The following named officers were elected: Directors, Robt. Amory, Wm. H. Hill, Jr., Francis W. Lawrence, F. H. Odiorne, A. W. Black; Clerk and Treasurer, Francis W. Lawrence. It was unanimously voted, in accordance with the recommendation made in the report of the President, that the capital stock be increased to \$450,000 by the issue of one thousand shares of \$100 each. The President explained that the increase of capital stock was desired for the purpose of absorbing the Suburban Light and Power Company, and of taking up electric lighting, heating and power, if the charter should be so extended by the Legislature. At a subsequent meeting of the directors Mr. Robt. Amory was chosen President.

Correspondence

[The JOURNAL is not responsible for the opinions expressed by correspondents.]

Mr. Egner in Reply to "A. S."

ST. LOUIS, MO., Jan. 23, 1887.

TO THE EDITOR AMERICAN GAS LIGHT JOURNAL:

On page 41, current volume of the JOURNAL, appeared an article, contributed under the *nom de plume* of "A. S.," that calls in question statements made in my communication published in your issue of December 16, 1886, p. 363. Now, "A. S." is mistaken in several things: First.—In assuming me to mean—where it is stated that a pound of coal (with oil) yielded 5.43 cu. ft. of 19.66 candle gas—that 2,211.2 lbs. of coal and 28.8 lbs. of naphtha yielded 12,163 cu. ft. of the gas. Having given the number of gallons of oil used per ton of coal, the writer wished to convey the idea that each pound of coal of that ton, aided by that number of gallons of oil per ton, gave the results stated—not a part of a ton of coal, but all of it, with the oil added. That accounts for some of the unaccounted-for pounds of gas noted by "A. S." Second.—One gallon of the St. Louis oil weighed 6½ lbs., not 6 lbs., as estimated by "A. S.;" and here we have a further hint in the accounting. Third.—In assuming the writer asserted that a certain number of cubic feet of 16 ("A. S." quotes 17) candle gas was all that could be obtained from a ton of the coal named. It is well known that in every retort house, under ordinary circumstances, more or less gas is being lost on account of leaky joints, porosity of the clay retorts, etc. If the exhauster is run fast enough to prevent this loss, we cannot help drawing in a trifle of air, or perhaps furnace gases; but at any rate 4.90 cu. ft. of 16-candle gas was all that the writer could obtain per pound of Youghiogheny coal when the latter was carbonized alone. When using the oil as described on p. 363, Vol. XLV., and again on p. 40, Vol. XLVI., we could so run the exhauster that the loss mentioned above was entirely prevented; and this addition to the yield, although secured from the coal, could not have been saved without the assistance of the oil, hence it was credited to the latter. Perhaps that will explain where some more of the gas, "the source of which cannot be discovered," came from. How many candle feet of gas may be obtained from a gallon of the grade of oil used in the Laclede works is an open question, and cannot in any manner be settled by assumption. The figures given in the "Chapter on Practical Gas Making" were taken from our carbonizing book, and were arrived at in the customary manner. The meter that registered the gas made was manufactured by the American Meter Company, and is fitted with an overflow, etc. It was tested again quite recently, and its correctness proved to a dot. The figures given by "A. S." are interesting and instructive, even though based somewhat on probabilities and assumptions; but mine were founded on the recorded results. It is hoped the above may account for all that gas the source of which "A. S." could not discover. Let me assure him it really was made, and let me also express the hope that "A. S." will strike me from his list (if he has one) of visionaries, of whom he mentions that Ohio man as a sample. Yours, etc., FREDERIC EGNER.

The Market for Gas Securities.

The city gas share market has developed much strength. All classes of gas securities are higher. Consolidated, on large transactions, sold up as high as 86 and a fraction, then reacted somewhat, but is decidedly strong. At noon to-day (Jan. 31) sales were made at 85½. There is a well-defined impression that the Company, last year, earned pretty close to 6 per cent. on its capital. Equitable is active and strong, and Mutual is fairly well sustained. At auction, Jan. 26, 274 shares Consolidated, at 84½; 200 Equitable, at 115½; 101 Mutual, at 102; 25 Brush Electric, at 104. In out-of-town shares we note that Brooklyn classes are strong. Most observers say that in any event the Legislature will not make a compulsory rate for gas in Brooklyn at a figure below \$1.50 per thousand. Louisville (Ky.) shares are higher. On Jan. 11th this Company declared a semi-annual dividend of 3 per cent. Augusta (Ga.) declared a 4 per cent. dividend on Jan. 19. Chelsea (Mass.) 3 per cent. Sales of Boston (Mass.) gas shares were recently made at 870; Newtown and Watertown (Mass.), at 140½; Roxbury (Mass.), at 190½. In fact a veritable boom appears to be in full swing.

Gas Stocks.

Quotations by Geo. W. Close, Broker and Dealer in Gas Stocks.

16 WALL ST., NEW YORK CITY.

FEBRUARY 2.

All communications will receive particular attention.

The following quotations are based on the par value of \$100 per share.

	Capital.	Par.	Bid	Asked
Consolidated.....	\$35,430,000	100	84½	85
Central.....	440,000	50	30	—
“ Scrip.....	220,000	—	47	57
Equitable.....	2,000,000	100	115	117
“ Bonds.....	1,000,000	—	113	115
Harlem, Bonds.....	170,000	—	—	—
Metropolitan, Bonds....	658,000	—	110	113
Mutual.....	3,500,000	100	102	104
“ Bonds.....	1,500,000	1000	101	—
Municipal, Bonds.....	750,000	—	—	—
Northern.....	125,000	50	36	—
“ Scrip.....	108,000	—	—	—
Yonkers.....	—	50	51	55
Richmond Co., S. I.	300,000	50	50	—
“ Bonds.....	12,000	—	—	—
Gas Co's of Brooklyn.				
Brooklyn.....	2,000,000	25	103	—
Citizens.....	1,200,000	20	—	68
“ S. F. Bonds....	320,000	1000	—	103
Fulton Municipal.....	3,000,000	100	135	—
“ Bonds....	300,000	—	—	106
Peoples.....	1,000,000	10	55	—
“ Bonds.....	290,000	—	100	—
“ “.....	250,000	—	100	—
Metropolitan.....	1,000,000	100	80	—
Nassau.....	1,000,000	25	101	—
“ Cfts.....	700,000	1000	100	—
Williamsburgh.....	1,000,000	50	123	—
“ Bonds... ..	1,000,000	—	107	—
Out of Town Gas Companies.				
Boston (Mass.) Gas Co.	2,500,000	500	870	875
Buffalo Mutual, N. Y....	750,000	100	90	95
“ Bonds... ..	200,000	1000	95	100
Citizens, Newark.....	1,000,000	50	140	145
“ “ Bonds.	45,000	—	—	—
Chicago Gas Co., Ills... ..	5,000,000	25	142	145
Peoples G. L. & C. Co.,				
Chicago, Ills.....	3,000,000	29	31	—
Cincinnati G. & C. Co..			198	200
Consolidated, Balt.....	6,000,000	100	56	60
“ Bonds....	3,600,000	—	107	107½
Chesapeake, Balt.....	1,500,000	100	79	80
“	1,000,000	—	100	102
Central, S. F., Cal.....			82½	84
Capital, Sacramento, Cal.			55	58
Consumers, Toronto....	1,000,000	50	194½	196½
Hartford, Conn.....	750,000	25	140	142
Jersey City.....	750,000	20	155	—
Laclede, St. Louis, Mo.	1,600,000	100	110	112

Louisville, Ky.....	1,500,000	50	113½	115
Little Falls, N. Y.....	50,000	100	95	100
“ Bonds	25,000	—	100	103
Montreal, Canada.....	2,000,000	100	209	215
New Haven, Conn.....		25	190	195
Oakland, Cal.....			35	36
Peoples, Jersey City... ..			25	30
“ “ Bonds..			—	—
Paterson, N. J.....		25	90	—
Rochester, N. Y.....		50	75	80
St. Louis, Missouri.....	600,000	50	—	475
San Francisco Gas Co.				
San Francisco, Cal....	10,000,000	100	60½	60½
Memphis (Tenn.) Gas... ..	750,000	100	80	82
“ Bonds.	240,000	100	103	—

Advertisers Index.

	Page
GAS ENGINEERS.	
Jos. R. Thomas, New York City.....	88
Wm. Henry White, New York City... ..	88
Wm. Farmer, New York City.....	88
William Gardner, Pittsburgh, Pa.....	88
GAS WORKS APPARATUS AND CONSTRUCTION.	
James R. Floyd, New York City.....	91
T. F. Rowland, Greenpoint, L. I.....	91
Delly & Fowler, Phila., Pa.....	91
Kerr Murray Mfg. Co., Fort Wayne, Ind.....	91
Stacey Mfg. Co., Cincinnati, Ohio.....	91
Bartlett, Hayward & Co., Baltimore, Md.....	91
Morris, Tasker & Co., Limited, Phila., Pa.....	93
Davis & Farnum Mfg. Co., Waltham, Mass.....	80
R. D. Wood & Co., Phila., Pa.....	90
Southwark Foundry and Machine Co., Philadelphia, Pa.....	90
PROCESSES.	
National Gas Light and Fuel Co., Chicago, Ills.....	80
American Gas Improvement Co., Pittsburgh, Pa.....	79
GAS AND WATER PIPES.	
Gloucester Iron Works, Phila., Pa.....	88
Warren Foundry and Machine Co., Phillipsburgh, N. J.....	88
Mellert Foundry and Machine Co., Reading, Pa.....	88
Cincinnati and Newport Iron and Pipe Co., Newport, Ky.....	88
Ohio Pipe Co., Columbus, Ohio.....	88
Pancoast & Rogers, New York City.....	88
M. J. Drummond, New York City.....	88
GAS ENGINES.	
Schleicher, Schumm & Co., Phila., Pa.....	64
Clerk Gas Engine Co., Phila., Pa.....	82
RETORTS AND FIRE BRICK.	
J. H. Gautier & Co., Jersey City, N. J.....	86
B. Kreischer & Sons, New York City.....	86
Adam Weber, New York City.....	86
Laclede Fire Brick Works, St. Louis, Mo.....	86
Brooklyn Retort and Fire Brick Works, Brooklyn, N. Y.....	86
Borgner & O'Brien, Phila., Pa.....	86
James Gardner, jr., Pittsburgh, Pa.....	86
Henry Maurer & Son, New York City.....	86
Chicago Retort and Fire Brick Works, Chicago, Ills.....	86
Baltimore Retort and Fire Brick Co., Baltimore.....	86
Oakhill Gas Retort and Fire Brick Co., St. Louis, Mo.....	86
Evens & Howard, St. Louis, Mo.....	87
Cincinnati Gas Retort and Fire Brick Works, Cincinnati, O.....	87
Emil Lenz, New York City.....	87
SCRUBBERS AND CONDENSERS.	
G. Shepard Page, New York City.....	89
REGENERATIVE FURNACES.	
Adam Weber, New York City.....	87
Bartlett, Hayward & Co., Baltimore, Md.....	87
GAS GOVERNORS.	
Connelly & Co., New York City.....	83
T. C. Hopper, Phila., Pa.....	84
CEMENTS.	
C. L. Gezould, Manchester, N. H.....	79
Howard Fleming, New York City.....	79
GAS ENRICHERS.	
Forest City Naptha Co., Cleveland, Ohio.....	92
GAS METERS.	
Harris, Griffin & Co., Phila., Pa.....	94
American Meter Co., New York and Philadelphia.....	95
The Goodwin Gas Stove and Meter Co., Philadelphia, Pa.....	95
Helme & Mellhenny, Phila., Pa.....	95
D. McDonald & Co. Albany, N. Y.....	95
Nathaniel Tufts, Boston, Mass.....	94
EXHAUSTERS.	
P. H. & F. M. Roots, Connerville, Ind.....	84
Smith & Sayre Manufacturing Co., New York City.....	90
Wilbram Bros., Philadelphia, Pa.....	92
Connelly & Co., New York City.....	84

GAS COALS.

Penn Gas Coal Co., Phila., Pa.....	93
Perkins & Co., New York City.....	92
Newburgh Orrel Coal Co., Baltimore Md.....	93
Despard Coal Co., Baltimore, Md.....	93
Chesapeake and Ohio R.R. Coal Agency, N. Y. City.....	93
Westmoreland Coal Company, Phila., Pa.....	93
Monongahela & Peters Creek Gas Coal Co., Pittsburgh, Pa..	93

CANNEL COALS.

Perkins & Co., New York City.....	92
J. & W. Wood, New York City.....	92

VALVES.

Ludlow Valve Manufacturing Co., Troy, N. Y.....	84
John McLean, New York City.....	84

ENGINES AND BOILERS.

Jarvis Engineering Co., Boston, Mass.....	79
---	----

PURIFYING MATERIAL.

S. H. Douglas, Ann Arbor, Mich.....	79
-------------------------------------	----

GAS LAMPS.

The Siemens-Lungren Co., Philadelphia, Pa.....	89
G. Shepard Page, New York City.....	87
Alho-Carbon Light Co., Newark, N. J.....	81
Crystal Carbon Light Co., Phila., Pa.....	82
Standard Gas Lamp Co., Phila., Pa.....	79
Geo. H. Gregory, New York City.....	79

PURIFIER SCREENS.

John Cabot, New York City.....	47
--------------------------------	----

GAS STOVES.

American Meter Co., New York and Philadelphia.....	85
The Goodwin Gas Stove and Meter Co., Phila. Pa.....	96

STREET LAMPS.

J. G. Miner, Morrisania, New York City.....	47
Bartlett Street Lamp Mfg Co., New York City.....	84

BURNERS.

G. Gefroerer, Phila., Pa.....	92
-------------------------------	----

STEAM BLOWER FOR BURNING BREASE.

H. E. Parson, New York City.....	58
----------------------------------	----

GASHOLDER TANKS.

W. C. Whyte, New York City.....	79
---------------------------------	----

GAS FIXTURES.

Mitchell, Vance & Co., New York City.....	79
---	----

STEAM PUMPS.

A. S. Cameron Steam Pump Works, N. Y. City.....	87
---	----

COKE CRUSHER.

C. M. Keller, Columbus, Ind.....	93
B. J. Allen, Newark, New Jersey.....	93

COAL HANDLING MACHINERY.

C. W. Hunt Company, New York City.....	84
--	----

WANTED,

By a practical man of many years' experience.

A Position as Superintendent of a Small Gas Works in a Growing Town,

where experience will be of value. Salary not so much an object. Best of references. Address 663-1 "R. A.," care this Journal.

WANTED,

Position as Asst. Engineer and Chemist.

A young man, graduate of Stevens Institute, who has had considerable experience in practical gas chemistry, desires position as Assistant Engineer and Chemist in a gas works. Can give good references. Address "M. E.," care this Journal.

SITUATION WANTED

By a Practical Gas Engineer.

For 18 years in charge of very successful operations of a coal gas works. Best of references given. Address "F. B.," care this Journal.

FOR SALE,

One Station Meter, 5 ft. by 5 ft., in perfect order.
One 12-in. Stat on Governor.
Six Sections of Hydraulic Main, 19 in. by 22 in., for benches of sixes.
Also, Monthpieces and Stand, Bridge, and Dip Pipes for 6 benches of sixes.

All the above in good condition. Apply to 658-61 NEWPORT GAS LT. CO., Newport, R. I.

FOR SALE,

Ten No. 2 Siemens Regenerative Gas Lamps,

With Factory Fixtures and Reflectors complete and in order. Only used three or four months. Will be sold cheap.

DANVILLE NAIL AND MFG. CO.,

Danville, Pa.

Superintendent's Position Desired

By a practical man of twenty-five years' experience in the manufacture and distribution of coal and water gas. Satisfactory references given. Address 646-tf "ENGINEER," care this Office.

ENGLISH

"Journal of Gas Lighting."

Issued weekly. New volume commences Jan. 1, 1887. Price, \$7 per annum. Subscriptions taken by

CHARLES NETTLETON, Agent for U. S.,
No. 115 BROADWAY, N. Y. CITY.

JARVIS ENGINEERING CO.,

61 Oliver St., Boston, Mass.

CONTRACTORS FOR ERECTING

COMPLETE STEAM OUTFITS FOR ELECTRIC LIGHTING STATIONS.

Steel Boilers set with Jarvis Pat. Boiler Setting,

To burn **COKE SCREENINGS** for Fuel.

ARMINGTON & SIMS CO. ENGINES,

Belting direct to Dynamos, without using Shafting.

SEND FOR CIRCULARS.

MITCHELL, VANCE & CO.,

MANUFACTURERS OF

Chandeliers

and every description of

GAS FIXTURES.

Also manufacturers of Fine Gilt Brouzes and Marble Clocks, warranted best time-keepers. Mantel Ornaments, etc.

Salesrooms, 836 Broadway, N. Y.

Special Designs furnished for Gas Fixtures for Churches, Public Halls, Lodges, etc.

HOWARD FLEMING,

23 Liberty St., New York.

IMPORTER OF

"BRIDGEND" "DINAS"

Silica FIRE Bricks

FOR COKE OVENS AND GAS WORKS.

PORTLAND AND ROMAN CEMENTS.

Correspondence Invited. Lowest Prices.

GEROULD'S IMPROVED RETORT CEMENT.

A Cement for patching retorts, putting on mouthpieces, and making up all bench-work joints. This Cement is mixed ready for use. Economic and thorough in its work. Fully warranted to stick. For recommendations and price list address

C. L. GEROULD,

Manchester, N. H.

Western Agent, H. T. GEROULD, Mendota, Ill.

GIBBS

PORTLAND CEMENT

Is guaranteed to be the finest English brand, and unsurpassed by any grade imported for making concrete and setting masonry.

Extract of Paper, with tests, read before the American Society of Civil Engineers, sent on application.

HOWARD FLEMING,

Sole Agent for U. S.,

23 Liberty St., New York.



STEPHEN A. MORSE, President.
GODFREY REBMANN, Vice-Pres.

M. B. DYOTT,
Superintendent.

EDWIN F. MORSE, Secretary.
CARLTON M. WILLIAMS, Treas.

STANDARD GAS LAMP CO.,

Office, 411 Cherry St. Factory, 1101, 1103 & 1105 Frankford Av.

Philadelphia, Pa.

It is to the interest of Gas Companies and Cities to use Dyott's Patent Champion Lamps, which give double the light with the same consumption of gas, and will save 50 per cent. over others in cost of keeping in repair. Gas Companies and others intending to erect Lamps of any description will do well to communicate with us. Special Drawings furnished and Estimates given on application upon Architects', Engineers' or our Draughtsmen's Plans.

Our Patent System of Instantaneously Lighting Gas (without electricity) for R. R. Depots is unequalled. Our High Candle Power Burner is superior to the Electric Light or any other High Candle Burner. We manufacture every description of Ornamental Lamps.

Illuminating Gas from Natural Gas,

AS MANUFACTURED UNDER THE

McKAY and CRITCHLOW PATENTS

BY THE

AMERICAN GAS IMPROVEMENT COMPANY, LIMITED.

PRINCIPAL OFFICE,

6234 Penn Avenue, Pittsburgh, Pa.

BRANCH OFFICES,

At Titusville and Beaver Falls, Pa.

W. H. DENNISTON, Chairman, Pittsburg, Pa.
W. B. ROBERTS, M.D., Titusville, Pa.
E. T. ROBERTS, Treasurer, Titusville, Pa.

{ HUGH McKAY, London, Ontario.
J. M. CRITCHLOW, Secretary, Beaver Falls, Pa.
JOHN McKAY, Superintendent, Titusville, Pa.

Should the supply of Natural Gas fail, will sell a plant and right to make Water Gas. Practicable at any Gas Works now in operation, and changes made with trifling cost. New apparatus, complete, with capacity of 50,000 to 600,000 feet per day, \$3,000 to \$10,000.

Guaranteed in Agreement to make Good, Cheap, Fixed Gas, or No Pay. Correspondence solicited.

Ferric Oxide for Gas Purification.

Ferric Oxide, as ground, screened, and prepared by me for purifying purposes, has now been in use for several years by many of the gas works throughout the country, including Detroit, Chicago, Milwaukee, East Saginaw, Burlington (Iowa), Ann Arbor, etc. It has proved, as I believe, the Most Effective and Economical Agent now in use. I am prepared to furnish the Oxide by the 100 lbs. or in car load lots, and will be pleased to give price f.o.b. cars at Ann Arbor or at place of destination. Address

S. H. DOUGLAS, Prest. Ann Arbor (Mich.) Gas Light Co.

GASHOLDER TANK CONSTRUCTION, ETC.

Gas Companies and others about to erect Gasholders will find it profitable to consult W. C. WHYTE, who for over thirty years has made a specialty of

Holder Tank Excavation and Mason Work.

Fifty tanks now in operation show the sort of work done. Address

W. C. WHYTE, No. 15 Cortlandt St., N. Y. City.

Gregory's Retort Incandescent Gas Lamps.

Manufactured under Patents granted and applied for. Over 20,000 sold in New York and Brooklyn. Over 100,000 sold in the U. S. in one year. It is the only lamp that can compete with Incandescent Electric Light. Gas Companies should see that it is on sale in their city or town. They can be attached to any bracket or fixture. A Complete Revolution in Gas Lighting. The invention of GEO. H. GREGORY, Gas Expert. A pure white light obtained from Gas, which is Superior to Electric Light. All lamps are finished in nickel plate. The construction of all lamps allows the gas to be superheated before passing through the tip, rendering the illuminating properties of the gas incandescent, which causes the Brightest Light ever obtained from Gas. Lamps made in all sizes. Gas Companies should assist in introducing this new lamp, which exceeds all other devices for gas lighting. This Cut represents Office and Bracket Lamp. Price, \$18 per dozen; discount 50 per cent. in half dozen lots or more. Send for Catalogue. Address

GEO. H. GREGORY, Mnfr., 337 Broadway, N. Y.

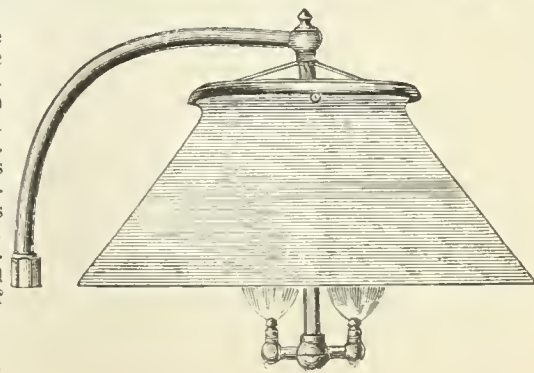

F. J. DAVIS & J. R. FARNUM,

TRUSTEES AND AGENTS FOR THE

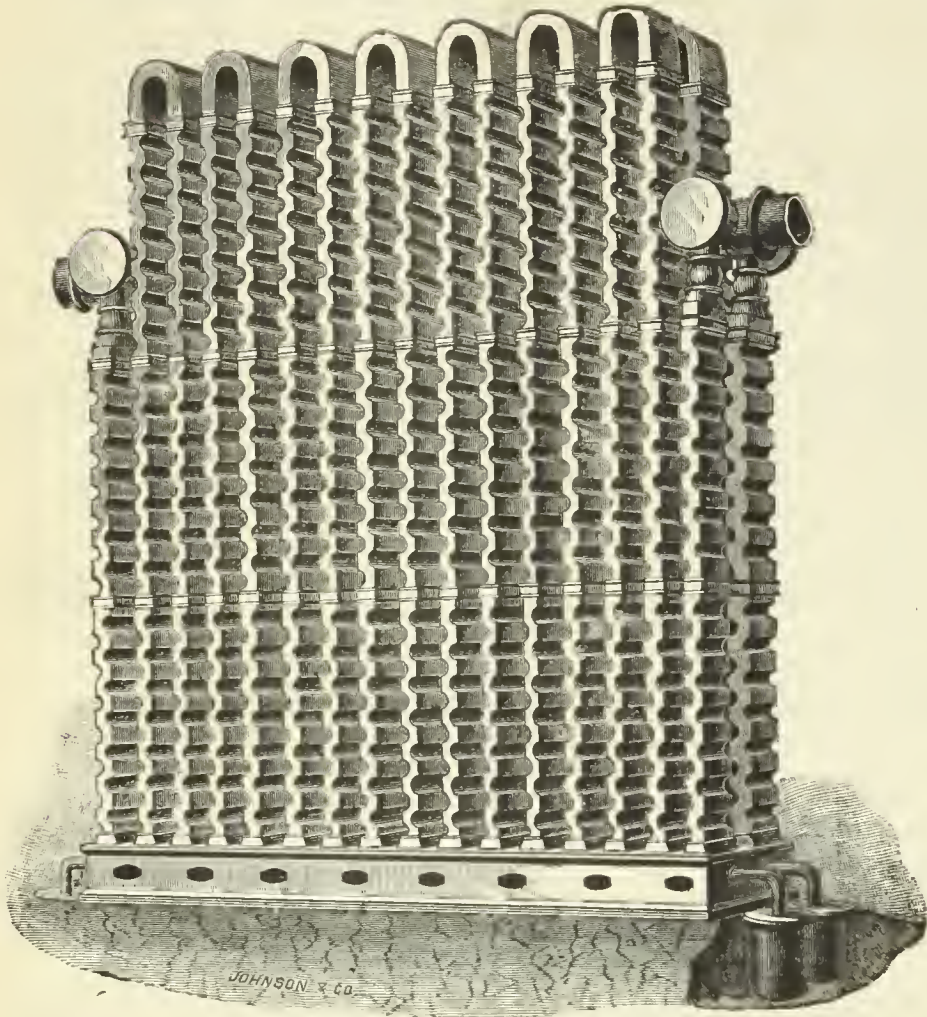
SINUOUS FRICTION CONDENSER.

We desire to draw the attention of the gas community to the merits of the SINUOUS FRICTION CONDENSER. Companies intending to introduce new condensers into their works will do well to confer with us and examine plans and estimates before contracting for any other pattern. The FRICTION CONDENSER is now in use at the gas works located in the following places:

Portland, Me.	Brookline, Mass.	Pawtucket, R. I.	Frederickton, N. B.
Newport, R. I.	Chelsea, Mass.	Jamaica Plain, Mass.	St. John, N. B.
Gloucester, Mass.	Woburn, Mass.	Attleboro, Mass.	Paterson, N. J.
Newton & Water- town, Mass.	Peoria, Ill.	Calais, Me.	Dover, N. H.
	Clinton, Mass.	Fall River, Mass.	Waltham, Mass.
		Nassau Works, Brooklyn, N. Y.	

DAVIS & FARNUM MFG. CO.

MANUFACTURERS OF

Gas and Water Pipes,

AND

GAS AND WATER MACHINERY

OF THE MOST APPROVED PATTERN.

Also. Gasholders and Iron Roofing.*Orders from Gas and Water Companies promptly attended to.***WALTHAM, MASS.**

Boston Office, Room 55, Mason Building, 70 Kilby Street.

DURING THE PAST YEAR, THE

NATIONAL GAS LIGHT AND FUEL CO.**218 LA SALLE ST., CHICAGO,**

Have Erected Twelve Sets of Water Gas Generating Apparatus under the *Springer Cupola* System. They are as follows:

Newton Illuminating Company, Newton, Kansas.— Daily capacity, 120,000 cu. ft.

Wellington Light & Heat Co., Wellington, Kansas.— Daily capacity, 120,000 cu. ft.

Chippewa Falls, Gas Light Co., Chippewa Falls, Wis.— Daily capacity, 120,000 cu. ft.

Elkhart Gas Light & Coke Co., Elkhart, Indiana.— Daily capacity, 120,000 cu. ft.

Madison City Gas Light Company, Madison, Wis.— Daily capacity, 120,000 cu. ft.

South Bend Gas Light Co., South Bend, Indiana.— Daily capacity, 250,000 cu. ft.

Sheboygan National Gas Comp'y, Sheboygan, Wis.— Daily capacity, 120,000 cu. ft.

Salina Gas Light Company, Salina, Kansas.— Daily capacity, 120,000 cu. ft.

Rathbun Company, Deseronto, Province Ontario.— Daily capacity, 80,000 cu. ft.

Jefferson City Gas Light Co., Jefferson City, Mo.— Daily capacity, 120,000 cu. ft.

Mankato Gas Light Company, Mankato, Minnesota.— Daily capacity, 80,000 cu. ft.

Minneapolis Gas Lt. & Coke Co., Minneapolis, Minn.— Daily capacity, 1,000,000 cu. ft.

1886**1886**

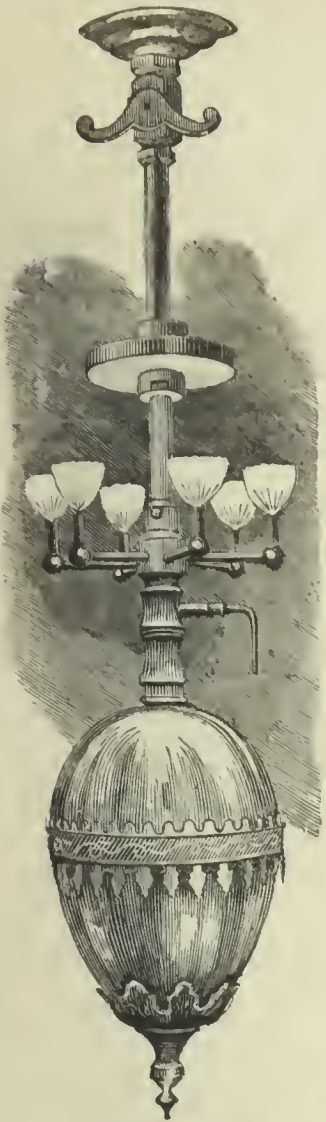

THE ALBO-CARBON LIGHT.

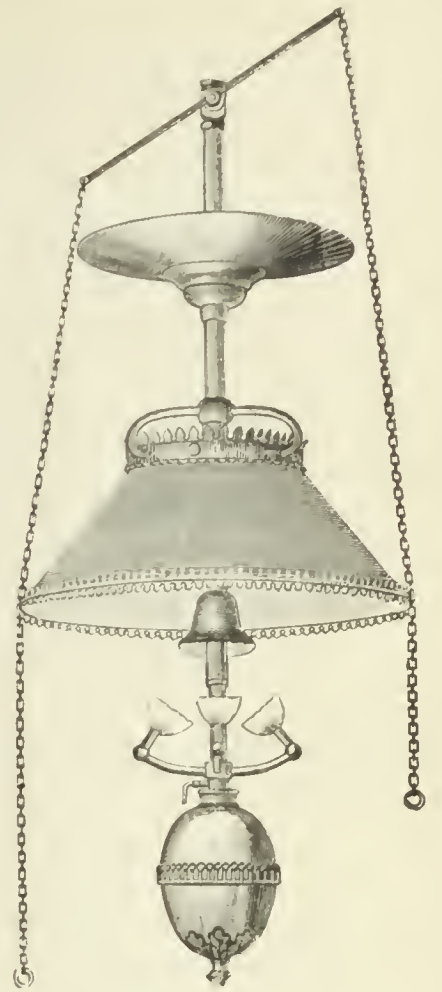

This most successful of all methods of enriching gas is based on the use of heated gas to vaporize a solid hydrocarbon, thus

COMBINING THE ADVANTAGES OF PREHEATING AND CARBURETTING.

The incoming gas passes over an extended heating surface (heated by means of the illuminating flames), and is raised to the temperature necessary to vaporize the carburetting material, which is a white, crystalline solid prepared from coal tar.

INJUNCTION CRANTED!

In the suit between this Company as complainant and Newman A. Ransom and the Chicago Gas Apparatus Manufacturing Company as defendants, pending in the Circuit Court of the United States for the Northern District of Illinois, on a late hearing of said cause before his Honor, Judge Gresham, Judge of said Court, an order was made and entered therein, a copy of which is hereto annexed, supporting our charge of infringement of our Letters Patent No. 247,925, dated Oct. 4, 1881, and of our Letters Patent No. 333,862, dated Jan. 5, 1886, and sustaining our rights under said several Letters Patent, to which especial attention is hereby directed, viz.:

UNITED STATES CIRCUIT COURT.

Northern District of Illinois.

WALTER J. KIDD

vs.

In Equity.

CHICAGO GAS APPARATUS MANUFACTURING COMPANY AND NEWMAN A. RANSOM.

The Bill of Complaint and the affidavits filed by the respective parties having been read and the arguments of the counsel for the respective parties having been heard and duly considered by the Court—C. K. Offield, Esq., of Offield, Towle & Phelps, for the Complainant, and John H. Whipple, Esq., of Merriam & Whipple, for the defendants—and it appearing that Letters Patent of the United States were issued in due form of law to Joshua Kidd, No. 247,925, dated October 4, 1881, for an Improvement in Apparatus for Enriching Gas, also Letters Patent of the United States to said Joshua Kidd No. 333,862, dated January 5, 1886, for an Improvement in Carburetting Attachments for Gas Fixtures, and that the title to said Letters Patent vests by mesne assignments in the complainant herein; and it appearing by the answer of the defendant corporation, the Chicago Gas Apparatus Manufacturing Company, that they have never

manufactured, used, or sold, or had anything whatever to do with any so-called apparatus for enriching gas of any kind or description whatever, or any carburetting attachment for gas fixtures of any kind or description whatsoever; and it appearing that said defendant, Newman A. Ransom, has infringed the second claim of said Letters Patent No. 247,925, dated October 4, 1881, and the first and second claims of said Letters Patent No. 333,862, dated January 5, 1886, by manufacturing and selling carburetting attachments for gas fixtures manufactured according to said Letters Patent contrary to the form of the statute in such case made and provided;

Now, therefore, it is hereby ordered, adjudged, and decreed, this 30th day of December, A. D. 1886, that an injunction be issued pursuant to the prayer of the Bill herein, strictly commanding and enjoining the said defendant, Newman A. Ransom, his clerks, attorneys, agents, servants, and workmen that they forthwith, and until the further order, judgment, and decree of this Court, desist from the making, using, or selling of any carburetting attachments for gas fixtures substantially as described and claimed in said Letters Patent in said above identified claims thereof; and that the complainant enter into Bond to be approved by the Clerk of said Court in the penal sum of two thousand dollars (\$2,000), to said defendant, Newman A. Ransom, conditioned to pay the defendant or his legal representative all such costs and damages as shall be awarded against the complainant in case the said injunction shall be dissolved, said Bond to be filed on or before the 22d day of January, 1887.

and our suit against W. S. Horry (trading as the Crystal Carbon Light Co.), Arthur Kitson (trading as Kitson & Co.), and others, defendants, for infringement of our Letters Patent above mentioned and referred to, pending in the Circuit Court of the United States for the Eastern District of Pennsylvania, has not yet been reached for hearing.

THE ALBO-CARBON LIGHT COMPANY, - - - NEWARK, N. J.,
Sole Manufacturers for the United States.

GAS ENGINES.

GAS ENGINES.

BOOKS.

THE CLERK GAS ENGINE CO.,

Main Office, 1012, 1014, 1016, 1018 Filbert St., Philadelphia, Pa.

WM. W. GOODWIN, Prest.

E. STEIN, Sec.

S. LEWIS JONES, Asst. Sec.

A. J. DOTY, Supt.

The utility and convenience of the Gas Engine being no longer an open question, it only remains now for intending purchasers to select the BEST. We claim for the CLERK GAS ENGINE that it is equal to any other manufactured as regards steadiness in running, simplicity, and ease of keeping in repair, and that it gives the greatest amount of power for the least money (both in first cost and expense of running) of any engine made. In support of this claim we refer to the test of the Gas Engines made under the direction of the American Institute of New York, in December, 1885, and heretofore published in these columns. These engines are especially adapted for continuous running under heavy loads, and we can refer to Engines which have run 22 hours a day for months at a time.

Made in Sizes of 5, 10, 15, 20, and 25 Horse Power. All Engines Guaranteed for One Year.

TRADE MARK.

THE CRYSTAL CARBON LIGHT!

The Latest and Most Improved Gas Light!

ADAPTED FOR PRIVATE RESIDENCES, CHURCHES, THEATERS, STORES, ETC.

These Burners are manufactured on the principle of enriching gas by means of Naphthaline (so-called Crystal Carbon or Albo-Carbon), the invention of the Rev. W. R. Bowditch, F.R.S., of Wakefield, England, who was the original inventor and patentee of this system of gas lighting.

SPECIAL NOTICE.

Many Gas Companies find the Crystal Carbon Light a valuable competitor against the Electric Light. It is ornamental, free from the defects common to all other enriching gas burners, and is as cheap as ordinary gas chandeliers. We sell direct to gas companies, giving them the benefit of agents' discounts.

CARBONCRYSTAL.

(Trade Mark.)

A new and superior preparation for enriching gas used in conjunction with Crystal Carbon or Albo-Carbon gas lights. The preparation is cleaner and better adapted for filling burner vessels than any hitherto produced. Guaranteed to be chemically pure. Supplied in cans from 10 pounds up.

THIS IS THE CHEAPEST AND PUREST FORM OF ENRICHING MATERIAL.

CRYSTAL CARBON LIGHT CO.,

Main Office, No. 1018 Chestnut Street, Philadelphia, Pa.

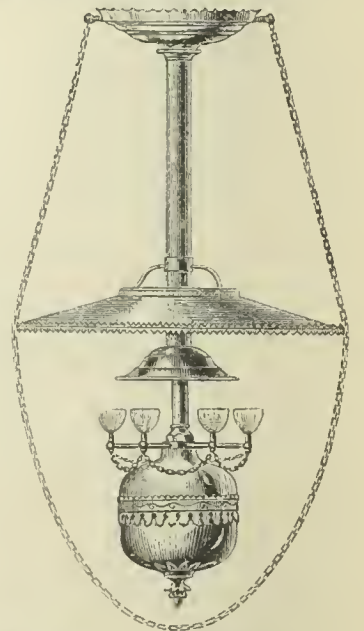

GAS

AS A SOURCE OF

LIGHT, HEAT, AND POWER.

By C. J. R. HUMPHREYS.

A Pamphlet of twenty-nine pages, treating of the use of Gas as a source of Light, Heat, and Power.

DESIGNED FOR DISTRIBUTION BY GAS COMPANIES AMONG THEIR CUSTOMERS AND OTHERS.

Price, 10 cents each, \$5 per 100, \$50 per 1,000.

Gas Companies can have their own imprint placed on cover without extra charge. All orders to be sent to

A. M. CALLENDER & CO.,

No. 42 Pine Street, N. Y. City.

CONNELLY'S AUTOMATIC GOVERNOR FOR STREET MAINS.

We invite the attention of all practical Gas Managers to the following letter and accompanying cut. The two lines show the pressure held by the Governor on Saturday and Sunday, and clearly illustrates the accuracy of the Governor in *increasing and reducing pressure in proportion to the volume of gas consumed.*

A Governor that puts the increased pressure on at "one fell swoop" and takes it off in like manner is *not* an "Automatic" Governor; and the circulation of pressure sheets showing such action by a so-called "Automatic" Governor is a rather amusing reflection on the intelligence of Gas Managers.

Strictly speaking, a "Balanced" Governor is an "Automatic" one, as it automatically varies the volume of gas sent out to *maintain a uniform pressure* at its outlet. But, as now applied, the term "Automatic Governor" is understood to mean a Governor that will *maintain pressure between any two desired extremes, in direct proportion to the volume of gas consumed.* Therefore pressure sheets showing *instantaneous changes* from maximum to minimum and *vice versa*, circulated broadcast as the record of an "Automatic (?) Governor," reveals inexcusable ignorance of the subject, amusing to many, yet liable to mislead the inexperienced novice.

We would suggest that all Gas Companies contemplating the placing of *Automatic* Governors would consult their own interests and avoid annoying experience by adopting a Governor *that has a record.*

CONNELLY & CO., LTD., 177 Broadway, N. Y.

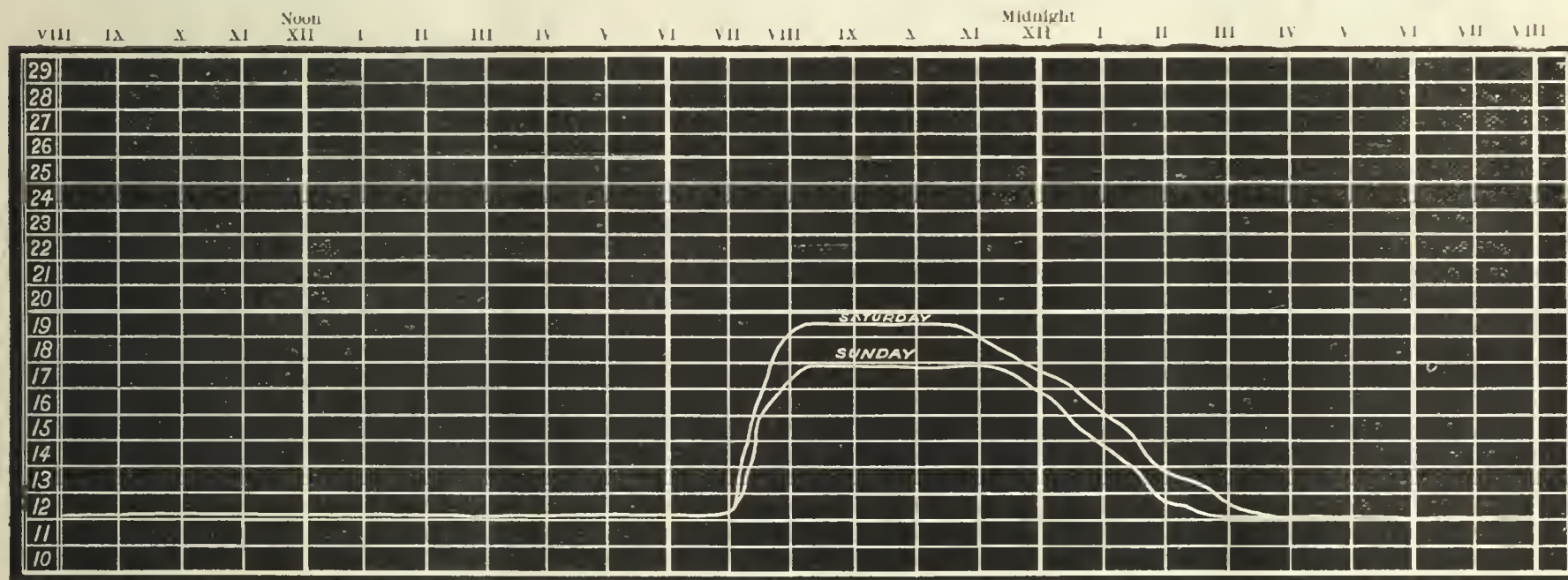

Card Showing Pressure at the Milwaukee Gas Works, Saturday, July 10, and Sunday, July 11 1886.

MILWAUKEE, Wis., August 3d, 1886.

MESSRS. CONNELLY & Co., LTD., 177 Broadway, New York:

Gentlemen—Replying to yours of 29th, I send you a little package of register sheets. When your Governor (20-inch) was set I adjusted it to give 13-tenths day pressure and 22-tenths night pressure. Saturday nights it would run up to 25-tenths. Whenever it would cloud up in the daytime it would go up at first indication of darkness to about 15-tenths. I hunted back in the sheets to find one when pressure was increased in the daytime, but it is so long since we have had a stormy day I could not find one. You can, however, see a *slight change* on sheets for June 1 and June 25. You will see, too, that lately the Governor only puts on *about 20-tenths maximum pressure.* This is because *less gas is burned than when it was adjusted.* We have no complaints of pressure, and everyone appears satisfied. In conclusion, can say the Governor has *never been touched* since it was first adjusted, and has at all times *done just the work we wished it to do.* Very truly yours, E. G. COWDERY, Engr. & Supt.

**T. C. HOPPER'S
AUTOMATIC DIFFERENTIAL GAS GOVERNOR**

Is now in Practical Operation, doing Perfect Automatic Service with Great Precision.

This Governor will do all and more than any other Governor on the Market.

BE SURE TO THOROUGHLY INVESTIGATE THE SUPERIOR MERITS OF THIS GOVERNOR BEFORE PURCHASING.

For Simplicity and Reliable Work it has no Equal. Correspondence Solicited.

T. C. HOPPER & CO., - - - - - Manufactory, 2227 Wood Street, Phila, Pa.

CONNELLY & CO., LTD.

MANUFACTURERS OF

Steam-Jet Exhausters

Requires one-half the floor space and one-third less steam than any other Exhauster in the market. More cheaply and easily connected, as outside by-pass valves are dispensed with. It is the only Exhauster manufactured having Compensator and Governor combined; the Compensator with all other Exhausters being a separate and distinct machine. It is simple in construction, easily adjusted, not liable to get out of order, and can be operated by ordinary workmen. Over 1,000 now in use.

No. 177 Broadway, New York.

LUDLOW VALVE MFG. CO.

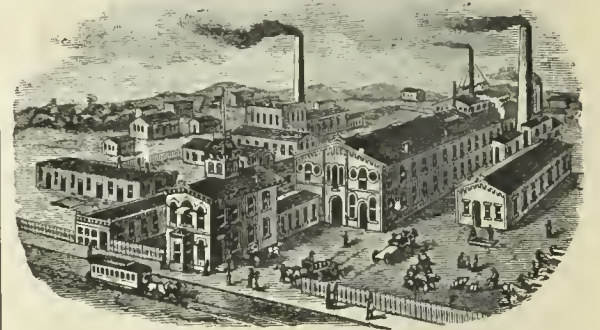

OFFICE AND WORKS,

935 to 954 River Street and 67 to 83 Vail Av. TROY, N. Y.

Hydraulic Main Dip Regulators, also Check Valves, Foot Valves, Yard-wash and Fire Hydrants. Send for Circulars.

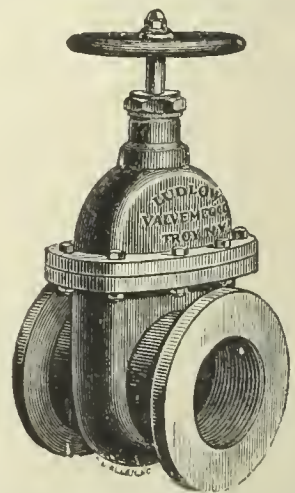

Valves.—Double and Single Gate, ½ in. to 48 in., outside and inside Screws. Indicator, etc., for Gas, Water, Steam, and Oil. Send for Circulars.

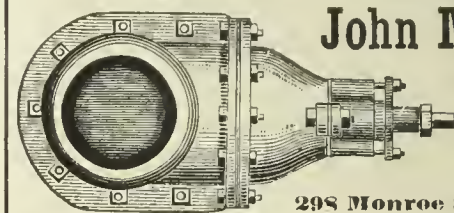

John McLean

Man'ufacturer of

GAS VALVES.

298 Monroe Street, N. Y.

GAS vs. ELECTRIC LIGHT.

We would invite attention to the able and exhaustive argument of General A. Hickenlooper, President of the Cincinnati Gas Light and Coke Company, contained in a handsome pamphlet of 96 pages, entitled

"EDISON'S INCANDESCENT ELECTRIC LIGHTS FOR STREET ILLUMINATION. REPORT OF AN ARGUMENT DELIVERED BY A. HICKENLOOPER BEFORE THE COMMITTEE ON LIGHT, MUNICIPAL COUNCIL, CITY OF CINCINNATI, JULY 22, 1886."

This is a subject of special interest to all Gas Light Companies.

Prices.

25 copies.....	\$7.50	100 copies.....	\$22.50
50 copies.....	12.50	250 copies.....	50.00

A sample copy will be sent by mail on receipt of 50 cts.

A. M. CALLENDER, & CO., 42 PINE ST., N. Y. CITY.

C. W. HUNT CO.,

No. 111 Broadway, N. Y. City.

MANUFACTURERS OF

Coal Handling Machinery,

AUTOMATIC RAILWAY, HOISTING ELEVATOR, CABLE RAILWAY, STEAM SHOVEL, HOISTING ENGINES, COAL TUBS, COAL & COKE CARS.

Plans and Specifications made for the

Erection of Coal Storage Buildings

Send for a Descriptive Pamphlet.

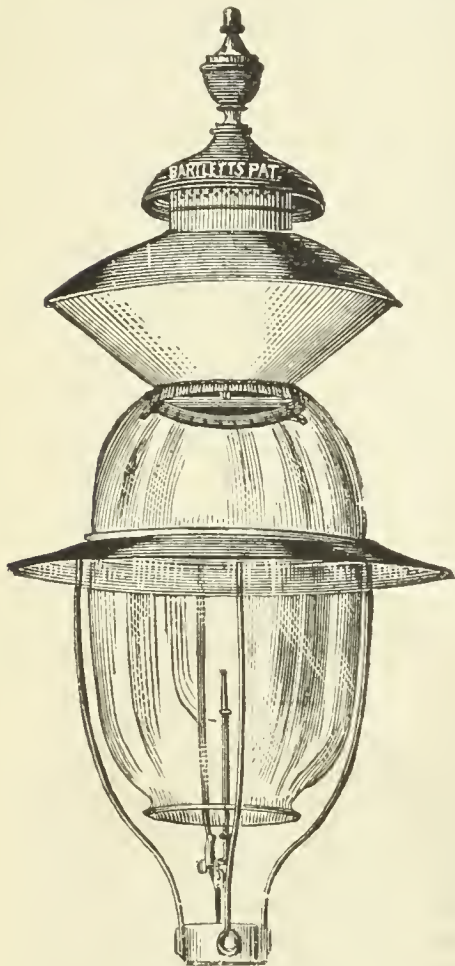

G. S. COOK, Pres. THOS. DAVENPORT (late Davenport Bros.), Sec. & Treas

**BARTLETT
Street Lamp Mfg. Co.**

MANUFACTURERS OF

Bartlett's Patent

GLOBE LAMPS.

FOR

Streets, Parks, Railroad Stations, Public Buildings, Etc.

LAMP POSTS A SPECIALTY.

Office and Salesroom

No. 35 Howard Street, N. Y. City.

Gas Companies and others intending to erect lamps and posts will do well to communicate with us.

F. M. ROOTS.

S. C. ROOTS

D. T. ROOTS.

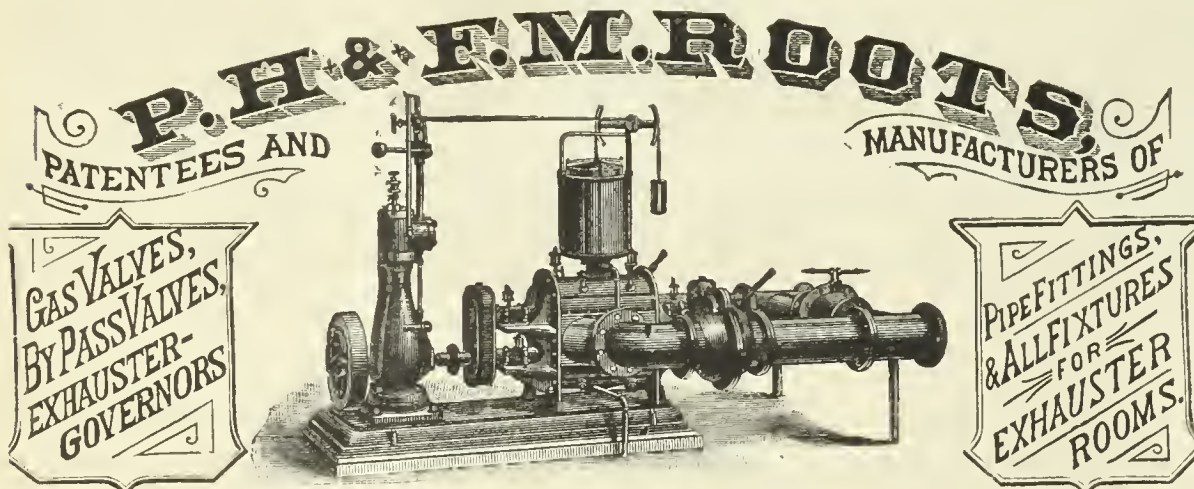

IMPROVED GAS EXHAUSTER,

WITH ENGINE ON SAME BED PLATE, OR WITHOUT.

BYE-PASSES, GAS VALVES, GOVERNORS, ELBOWS, PIPE-FITTINGS, Etc., FURNISHED TO ORDER,

P. H. & F. M. ROOTS, Patentees & Manufacturers, **CONNERSVILLE, IND.**

S. S. TOWNSEND, General Agent, 22 Cortland St.

COOKE & CO., Selling Agents, 22 Cortland St., N. Y.

✦ SEND FOR ILLUSTRATED CATALOGUE AND PRICE LIST. ✦

GAS STOVES.

GAS STOVES.

GAS STOVES.

THE AMERICAN METER CO.,

MANUFACTORIES,

508 to 514 West Twenty-second St., N. Y.

Arch and Twenty-second St., Phila.

Nos. 244 & 246 North Wells Street, Chicago, Ill.

AGENCIES,

No. 177 Elm Street, Cincinnati, Ohio.

Nos. 122 & 124 Sutter Street, San Francisco Cal.

No. 810 North Second Street, St. Louis, Mo.

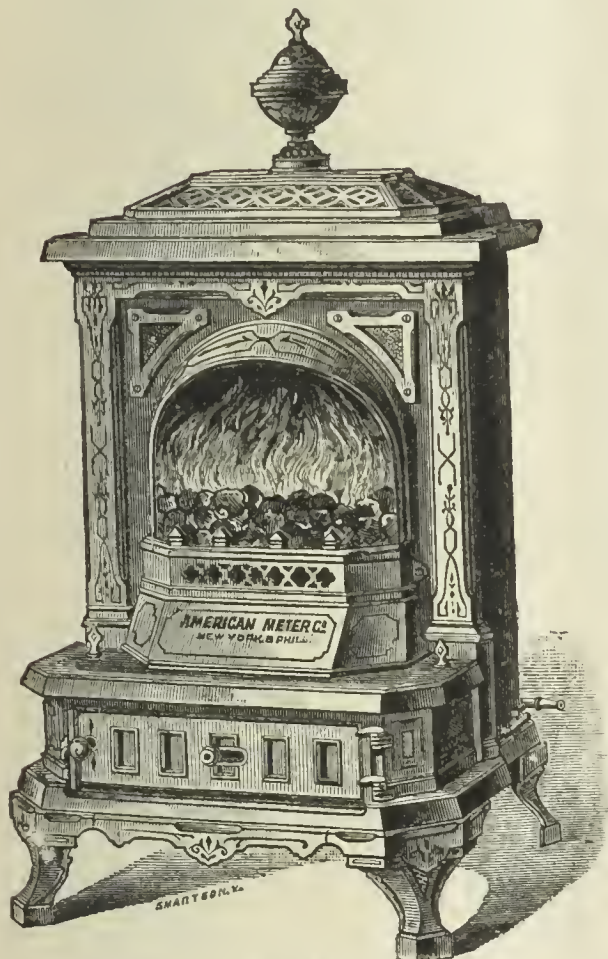

Open Fire Place Heater No. 19.
Fitted with the new Incandescent Gas Fire.

NEW INCANDESCENT

Gas Fires

AND

OPEN

Fire Place Heaters.

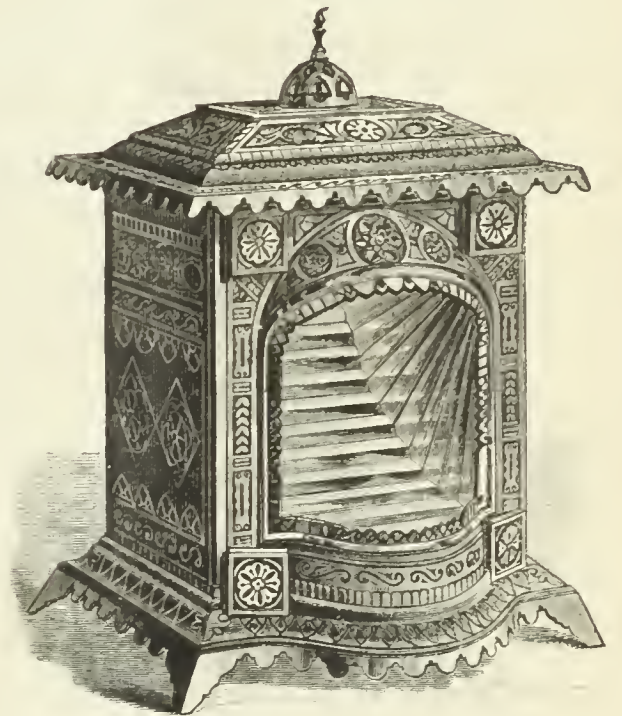

Open Fire Place Heater No. 17C.
Fitted with Illuminating Burners and Copper Reflectors.

We call attention to Special Apparatus Heated by Gas for Manufacturing Purposes.

GAS FURNACES FOR TINMEN'S USE; FURNACES FOR MELTING SOLDER AND TYPE METAL; APPARATUS FOR BENDING CARRIAGE PANELS, NOW IN SUCCESSFUL OPERATION IN CARRIAGE MANUFACTORIES; WATER HEATERS FOR KITCHEN BOILERS, BATHS, ETC., AND FOR ATTACHING TO HEATING COILS AND PIPES FOR CONSERVATORIES.

THE COMPANY MANUFACTURE

GAS STOVES FOR COOKING AND HEATING PURPOSES

In all Sizes, for Domestic, Restaurant, and Hotel Use.

These Stoves may be seen in operation at our Retail Store, No. 223 Sixth Avenue, N. Y. Call and examine.

SEND FOR CATALOGUE OF TWENTY DIFFERENT STYLES OF HEATING STOVES.

RETORTS AND FIRE BRICK.

J. H. CAUTIER & CO.,

CORNER OF
GREENE AND ESSEX STREETS,
JERSEY CITY, N. J.

MANUFACTURERS OF

**Clay Gas Retorts,
Gas House Tiles,
Fire Bricks, Etc. Etc.**

Ground Clay, Fire Brick and
Fire Sand in Barrels,

J. H. GAUTIER.
C. E. GREGORY.

T. B. GAUTIER.
C. E. GAUTIER.

BROOKLYN

Clay Retort & Fire Brick Works,

(EDWARD D. WHITE & CO.)

Manufacturers of Clay Retorts, Fire Brick,
Gas House and other Tile.

VAN DYKE, ELIZABETH, RICHARDS & PARTITION STS.
Office, 88 Van Dyke St., Brooklyn, N. Y.

RETORTS AND FIRE BRICK.

LACLEDE FIRE BRICK MFG. CO.,

MANUFACTURERS OF

Fire Brick, Gas Retorts,

AND

ST. LOUIS STANDARD SEWER PIPE.

Blast Furnace and Cupola Linings, every description of Fire
Clay Material, Fire Clay Flue Linings, Chimney Tops
Dry Milled and Crude Fire Clays, etc.

OFFICE AND DEPOT

901, 903, and 905 Pine Street,
ST. LOUIS, MO.

ESTABLISHED IN 1845.

B. KREISCHER & SONS,

OFFICE FOOT OF HOUSTON ST., E.R., N.Y.

Gas Retorts,

TILES, FIRE BRICK.

AND EVERYTHING IN THE FIRE CLAY LINE.

RETORTS AND FIRE BRICK.

MANHATTAN

FIRE BRICK & ENAMELLED CLAY

RETORT WORKS.

ADAM WEBER.

CLAY GAS RETORTS

AND RETORT SETTINGS

FIRE BRICKS, TILES, ETC.,

Office and Works, 15th Street and Avenue C., N. Y.



Works,
LOCKPORT STATION, PA.

—ESTABLISHED 1864.—

JAMES GARDNER, JR.,

Successor to WILLIAM GARDNER & SON.

Office, Rooms 19 & 20, Lewis Block,
PITTSBURGH, PA, P. O. Box 373.

Fire Clay Goods for Gas Works.

CHAS. H. SPRAGUE & SON, No. 70 KILBY STREET, BOSTON, MASS., Agents for the New England States.

OFFICE, 418 to 422 East 23d St., New York.

ESTABLISHED 1856.

WORKS, PERTH AMBOY, NEW JERSEY.

HENRY MAURER & SON,

Excelsior Fire Brick & Clay Retort Works

CLAY GAS RETORTS, BENCH SETTINGS, FIRE BRICK, TILES, ETC.

CHICAGO

Retort & Fire Brick Works,

OFFICE AND FACTORY,
Clark, Forty-Fifth, and La Salle Streets,
CHICAGO, ILL.

GEORGE C. HICKS, PRES. PAUL P. USTIN, SEC. & TREAS.

STANDARD

Clay Retorts and Settings.

BLOCKS & TILES

Of every Shape and Size to Order.

Standard Fire Bricks.

NEWBIGGING'S

Gas Manager's Handbook.

Price, \$4.80.

EVERY GAS MAN SHOULD HAVE ONE.

Orders may be sent to this Office.

OAKHILL

GAS RETORT & FIRE BRICK

Works.

Proprietors,

PARKER-RUSSELL MINING & MFG. CO.

City Office, 711 Pine Street,

ST. LOUIS, MO.

Our immense establishment is now employed almost entirely in
the manufacture of

MATERIALS FOR GAS COMPANIES.

We have studied and perfected three important points. Our retorts are made to stand changes of temperature, the strongest heats of the furnace, and the abrasion of feeding and emptying. Our customers are in almost every State of the Union, to all of whom we refer.

THOS. SMITH, Prest. AUGUST LAMBLA, Vice-Prest. & Sup

BALTIMORE

RETORT & FIRE BRICK CO.

MANUFACTORY AT

LOCUST POINT, BALTIMORE, MD.

Connection with the City by Telephone.

Clay Retorts, Blocks & Tiles,

FIRE BRICK, FIRE CLAY,

AND FIRE CEMENT.

Red and Buff Ornamental Tiles and Chimney
Tops. Drain and Sewer Pipe (from
2 to 30 inches). Baker Oven Tiles
12 x 12 x 2 and 10 x 10 x 2.

WALDO BROS., 88 WATER ST., BOSTON, MASS

Sole Agents the New England States

RETORTS AND FIRE BRICK.

EVENS & HOWARD,

916 Market St., St. Louis. Mo.
Works, Howard Station, Mo. Pacific R.R.

Fire Brick, Gas Retorts

AND

RETORT SETTINGS.

Sewer Pipe, 3 to 24 in. diameter.

Glass Pot Clay, Ground Fire Clay, in barrels and in bulk. All kinds of Fire Clay Goods.

Cincinnati Gas Retort & Fire Brick Works.

—ESTABLISHED 1872.—

CHAS. TAYLOR,

MANUFACTURER OF

Gas Retorts, Fire Brick, and Tile.

Blast Furnace Linings, Cupola Blocks, Boiler Tiles, Grate Settings, and Stove Linings. Fire Cement, Fire Clay, Fire Sand, and all other Fire Clay Goods.

Branch Works, New Cumberland, W. Va.

GENERAL OFFICE AND WORKS,

Burns St., Cincinnati, Ohio.

Stettiner

**Chamotte Fabrik Actien
Gesellschaft,**

Formerly DIDIER,

(Patentees of the Dr. Schilling & Dr. Bunte
Regenerative Furnace)

STETTIN, GERMANY.

The attention of all Gas Engineers is called to our Fire-Proof
Material, viz.:

CLAY GAS RETORTS

(ENAMELED AND UNENAMELED),

Blocks, Tiles

AND

EXTRA FIRE BRICK,

Pronounced by the highest authorities as superior to and excelling any other similar manufacture. The component of aluminum contained in our material (up to 45 per cent.) is larger than in any other material heretofore sold in the United States; whilst the uniformity of the goods is assured by the most scrupulous analysis of the clay used.

For any further information and prices please apply to

EMIL LENZ,

2 & 4 Stone St., Room 19, N.Y. City.

PATENTS.

FRANKLIN H. HOUGH,

Solicitor of American & Foreign Patents

925 F. ST., WASHINGTON, D. C.

(NEAR U. S. PATENT OFFICE.)

Personal attention given to the preparation and prosecution of applications for Letters Patent. All business before the U. S. Patent Office attended to for moderate fees. **No Agency in the United States possesses superior facilities for obtaining Patents,** or for ascertaining the patentability of inventions. Copies of patents furnished for 25 cents each. Correspondence solicited.

REGENERATIVE FURNACES.

STEAM PUMPS.

ADAM WEBER'S

New and Improved Regenerative Furnace.

ESPECIALLY ADAPTED FOR USE IN SMALL GAS WORKS.

**A Saving of at Least Forty per Cent. over
Old Methods.**

Cheapness of construction and absence of elaboration are the chief characteristics of this Furnace. It is also applicable in cases where it is not convenient to excavate deeply below the line of the retort house.

Correspondence respectfully solicited. Descriptive Circulars on application.

Manhattan Fire Brick & Enameled Clay Retort Works.

OFFICE, 633 EAST FIFTEENTH STREET, N. Y. CITY.

MUNICH REGENERATIVE FURNACE

System Drs. Schilling and Bunte.

Greatest Durability! Minimum of Attention!

COMPLETE DISTILLATION IN 3½ HOURS.

Ten to Thirteen Pounds of Coke to Hundredweight of Coal.

NO CLINKER. NO CARBONIC OXIDE IN THE REGENERATIVE FLUES.

Almost Automatic in Action.

The Most Successful Regenerative Furnace in Use.

BARTLETT, HAYWARD & CO.

Agents for the United States.



THE A. S. Cameron Steam Pump,

THE STANDARD OF EXCELLENCE.

Upward of 30,000 in Use.

BEST GAS WORKS PUMP
Ever Introduced.

Adapted to Every Possible Duty.

A. S. Cameron Steam Pump Works.

Foot East 23d St., N. Y.

GEO. SHEPARD PAGE,

No. 69 Wall Street, N. Y. City.

REPRESENTING

THE BOWER GAS LAMP.

C. & W. Walker's Carbonic Acid & Tar Extracting Washer

B. DONKIN & CO.'S PAT. IMP. GAS VALVE.

Young & Beilby's Patents. Henry Aitkin's Patents.

R. P. SPICE, London, Eng. HENRY SIMON, Manchester, Eng.

GAS AND WATER PIPES.

GAS AND WATER PIPES.

ENGINEERS.

SAM'L R. SHIPLEY, Pres.
HENRY B. CHEW, Treas.

JAS. P. MICHELLON, Sec.
WM. SEXTON, Supt.

GLOUCESTER IRON WORKS,
GLOUCESTER CITY, N. J.



Cast Iron Gas & Water Pipes, Stop Valves, Fire Hydrants, Gasholders. &c.

Office No. 6 North Seventh Street, Philadelphia.

ESTABLISHED 1856.

WARREN FOUNDRY AND MACHINE CO.,

WORKS AT PHILLIPSBURGH, N. J.
NEW YORK OFFICE, 162 BROADWAY.

Cast Iron Water and Gas Pipe

FROM TWO TO FORTY-EIGHT INCHES DIAMETER.
ALSO ALL SIZES OF

FLANGE PIPE for Sugar House and Mine Work.
Branches, Bends, Retorts, Etc., Etc.

436-1

MATHEW ADDY, President.

W. L. DAVIS, Selling Agent.

GEO. P. WILSHIRE, Sec. & Treas.

Cincinnati and Newport Iron and Pipe Company,
NEWPORT, KY.

Lamp Posts
AND
BENCH CASTINGS

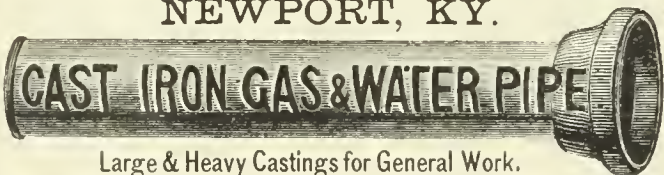

Branch
AND
SPECIAL CASTINGS

A Specialty.

Large & Heavy Castings for General Work.

FOR GAS & WATER CO'S.

Manufacture Pipe from 2 to 48 inches. All work guaranteed first quality.

Pancoast & Rogers.

WROUGHT IRON PIPE,

VALVES AND GATES,

Cast Iron Gas & Water Pipe.

28 Platt and 15 Gold St., New York.

The Management of Small Gas Works.

By C. J. R. HUMPHREYS. Price, \$1.

A. M. CALLENDER & CO., 42 Pine St., N. Y.

P. D. WANNER, Chairman. A. H. MELLERT, Sec. & Treas.

MELLERT FOUNDRY & MACHINE CO., Ltd.
Reading, Pa.



Specials—Flange Pipe, Valves and Hydrants,
Lamp Posts, Retorts, etc.

General Foundry and Machine Work.

JOHN FOX, Selling Agent. 160 Broadway, N. Y.

THE OHIO PIPE COMPANY,

MANUFACTURERS OF

Cast Iron Gas & Water Pipe,

BRANCH AND SPECIAL CASTINGS.

Gas-House Bench Castings, Hydraulics, Lamp Posts, Flange Pipe
and Specials, Architectural Castings, Building Columns,
Joists, Cellar Grates, Sash Weights, etc.

GENERAL FOUNDERS AND MACHINISTS.

Columbus, Ohio.

M. J. DRUMMOND,



SPECIAL CASTINGS AND LAMP POSTS.

95 Liberty St., - New York.

JOS. R. THOMAS, C.E.,

May be Consulted on all Mat-
ters Relating to Gas Works
and Gas Manufacture.

ADDRESS THIS OFFICE.

WM. FARMER, ENGINEER,
32 Park Place, Room 36, New York.

THE CHEMIST'S ASSISTANT; OR, KINDERGAR-
TEN SYSTEM OF CHEMISTRY.

A system by which the elements and their valences are repre-
sented by illustrations and solid bodies.

BOX AND PAMPHLET COMPLETE, \$2.50.

WM. HENRY WHITE,

CONSULTING AND CONSTRUCTING

Gas Engineer & Contractor

Estimates, Plans, and Specifications furnished for new wo
extensions of existing works.

No. 32 Pine Street, New York City.

Correspondence solicited.

WM. GARDNER,
Gas Engineer,

Lewis Block, Room 20, Pittsburgh, Pa.

Those who intend to make alterations in existing gas plants, or
who contemplate the erection of new works, will find it to their
interest to open correspondence with the above. Plans made
and estimates furnished.

GAS LAMPS.

SCRUBBERS AND CONDENSERS.

The Siemens and Lungren REGENERATIVE GAS LAMPS.

A System of Burning Gas whereby its Illuminating Power is Increased from 300 to 400 per ct. without the Expense, Trouble and Annoyance resulting from the use of Hydrocarbon Enriching Material.

The Siemens-Lungren Company received the only Silver Medal or Highest Award for Gas Burners at the "Novelties" Exhibition of the Franklin Institute, held at Phila., Oct., '85.

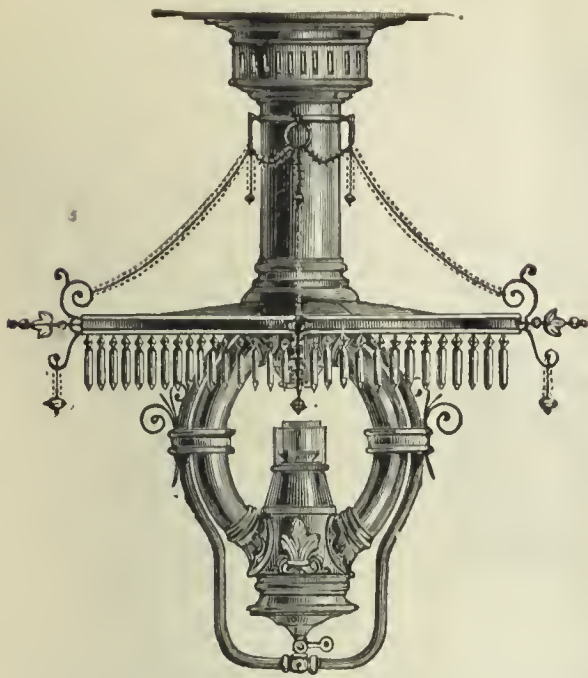

SIEMENS LAMP.

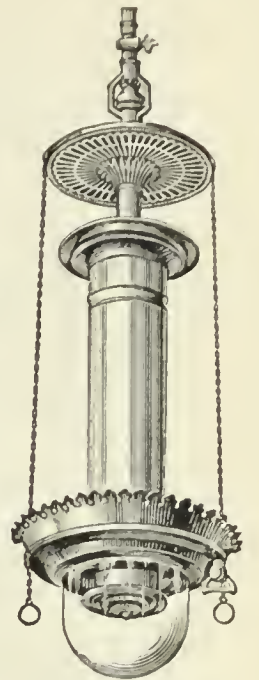

LUNGREN LAMP

THIRTEEN CANDLE POWER PER CUBIC FOOT OF GAS!

This result is obtained

SIMPLY BY THE SCIENTIFIC APPLICATION OF THE REGENERATIVE PRINCIPLE.

Consequently this largely increased illumination is always maintained without further cost and frequent attention.

THE SIEMENS-LUNCREN COMPANY,

N. E. Cor. 21st. St. and Washington Av., Phila., Pa.

THE PATENT "STANDARD" WASHER-SCRUBBER

Has been adopted by gas companies in all parts of the world. Between 300 and 400 companies, with the enormous daily output of over 300,000,000 cubic feet, are now using it. "Standard" Washer-Scrubbers have been erected for the following gas light companies since Jan. 1, 1886:

WALLASEY, ENGLAND.....	750,000 cubic feet.	RICHMOND, SURREY, ENGLAND.....	1,500,000 cubic feet.
NEWARK, ENGLAND.....	350,000 "	BRIDGEPORT, U. S.....	500,000 "
BUFFALO, U. S. (MUTUAL).....	500,000 "	TORONTO, CANADA.....	1,000,000 "
BERLIN, GERMANY.....	1,250,000 "	HARTFORD, U. S.....	1,000,000 "
SO. BRISBANE, AUSTRALIA.....	300,000 "	DETROIT, U. S.....	750,000 "
LEEDS, ENGLAND.....	2,600,000 "	SINGAPORE, CEYLON.....	300,000 "
FURTH, GERMANY.....	400,000 "	BRUNSWICK, GERMANY.....	300,000 "
FREIBURG, GERMANY.....	200,000 "	LILLE, FRANCE.....	750,000 "
NINE ELMS, LONDON.....	3,000,000 "	CADIZ, SPAIN.....	300,000 "
MELBOURNE, AUSTRALIA (2).....	3,000,000 "	READING, ENGLAND.....	2,000,000 "
GLUCKAUF COKE WORKS, GERMANY.	200,000 "	LINCOLN, U. S.....	250,000 "
BOURNEMOUTH, ENGLAND.....	1,000,000 "	ST. LOUIS, U. S. (LACLEDE).....	1,000,000 "
		BROOKLYN, U. S.....	2,000,000 "

That this apparatus is really the *standard* is indicated by the following names of important houses who represent this invention in the different countries of the world:

FRANCE & BELGIUM, Mons. J. A. Berly, 31 Rue Boinod, Paris. HOLLAND & DUTCH COLONIES, Mess. W. Hoven & Zoon, Rotterdam.

GERMANY and AUSTRO-HUNGARY, Berlin-Anhaltische-Actiengesellschaft, Berlin, Moabit, and Dessau.

RUSSIA, Mr. F. Bley, Galernaya, 44, St. Petersburg. SPAIN, Mess. Nicolas, Chamon, Foiret & Cie., 29 Rue Claude-Vellefaux, Paris.

ITALY & MALTA, Sig. E. Canziani, 26 & 28 Portici, Vittorio Emmanuele, Genoa. Sig. Fratelli Scheuer, Via Chiaja, 124, Naples.

NEW SOUTH WALES, Messrs. W. Coward & Sons, 143 Queen Victoria St., London.

NEW ZEALAND and VICTORIA, Messrs. G. D. Jennings & Co., 28 Gracechurch St., London.

Companies in the U. S. adopting this apparatus can now be assured of a market for the Ammoniacal Liquor at a remunerative price. Correspondence for purchase of "Standards" and Ammoniacal Liquor is solicited by the

SOLE AGENT AND MANUFACTURER FOR THE WESTERN HEMISPHERE,

GEO. SHEPARD PAGE, 6 WALL STREET, NEW YORK.

GAS WORKS APPARATUS AND CONSTRUCTION.

GAS WORKS APPARATUS AND CONSTRUCTION.

WORKS: { MILLVILLE, N. J.
FLORENCE, "
CAMDEN, "

R. D. WOOD & CO.,

OFFICES: { 400 CHESTNUT ST.,
PHILADELPHIA.

GAST-IRON PIPE 1½ to 72 Inches in Diameter.

Water Machinery and Gas Apparatus.

HEAVY CASTINGS.

HOLDERS,

LAMP POSTS,

VALVES,

PURIFIERS,

CONDENSERS,

BENCH WORK,

METER CASES.

FLOORS AND ROOFS,

FLANGED PIPE,

FIRE HYDRANTS,

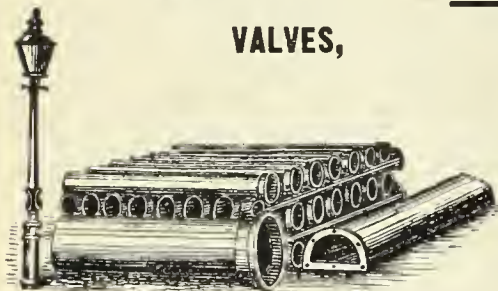

Estimates and Specifications for
NEW WORKS or **EXTENSIONS**
or **ALTERATIONS** of **OLD ONES.**

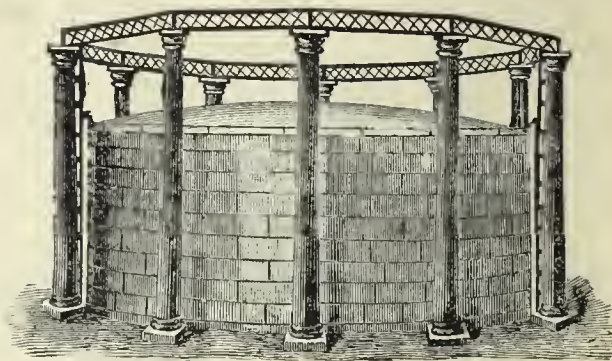

SMITH & SAYRE MFG. COMPANY,

G. G. PORTER, Prest.

245 Broadway, N. Y.

CHAS. W. ISBELL, Sec'y.

Machinery & Apparatus for Gas Works

Drawings, Plans, and Estimates Furnished for the Improvement, Extension, or Alteration of Gas Works, or for the Construction of New Works.

Mackenzie's Patent Rotary and Steam Jet Gas Exhausters, Governors, Compensators, Condensers, Washers, Scrubbers. Isbell's Patent Automatic Street Pressure Governor, Gas and Water Valves, Hydraulic Main Dip Regulator, Bench Castings, etc. Purifying Boxes and "Standard" Scrubbers. Isbell's Patent Self-Sealing Retort Doors.

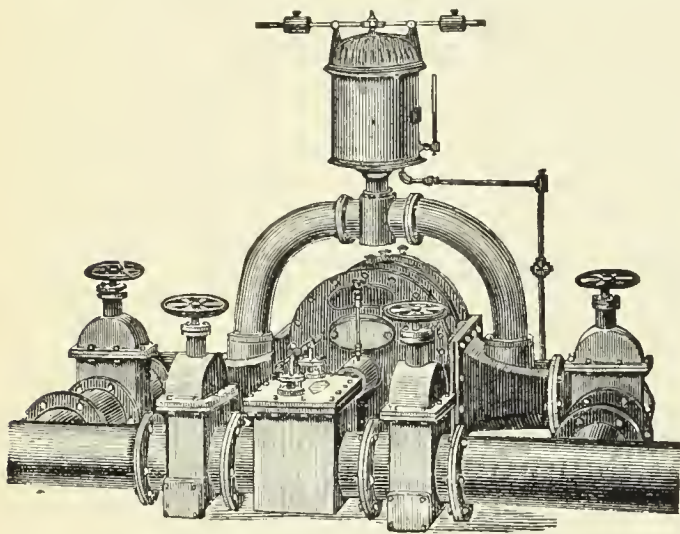

SOUTHWARK FOUNDRY AND MACHINE COMPANY,

Successors to MERRICK & SONS,

GAS APPARATUS,

Holders, Purifiers, Washers, Etc., Etc. Boiler and Tank Work. Steam Engines. Hydraulic Machinery. Bessemer Plants, Etc.

Washington Ave. and Fifth Street, Philadelphia, Pa.

MORRIS, TASKER & CO.,

Limited,

Builders of Gas Works,

PHILADELPHIA PA.

GOODWIN'S DIRECTORY

OF THE

GAS LIGHT COMPANIES OF THE UNITED STATES & CANADA

Price, \$10.00.

Orders may be sent to

A. M. CALLENDER & CO., No. 42 Pine Street, N. Y. City.

GAS WORKS APPARATUS AND CONSTRUCTION.

GAS WORKS APPARATUS AND CONSTRUCTION.

JAMES R. FLOYD,

(SUCCESSOR TO HERRING & FLOYD)

Oregon Iron Works,

531 to 543 West 20th St., N. Y.

Practical Builders of Gas Works,

MANUFACTURERS OF

ALL KINDS OF CASTINGS

AND

APPARATUS FOR GAS-WORKS.

BENCH CASTINGS

from benches of one to six Retorts each.

WASHERS: MULTITUBULAR AND AIR CONDENSERS; CONDENSERS; SCRUBBERS

wet and dry), and

EXHAUSTERS

for relieving Retorts from pressure.

BENDS and BRANCHES

all sizes and description.

FLOYD'S PATENT

MALLEABLE RETORT LID.

PATENT

SELF-SEALING RETORT LIDS.

FARMER'S

PATENT BYE-PASS DIP-PIPE.

SABBATON'S PATENT

FURNACE DOOR AND FRAME.

BUTLER'S

COKE SCREENING SHOVELS.

GAS GOVERNORS,

and everything connected with well regulated Gas Works at low price, and in complete order.

SELLER'S CEMENT

for stopping leaks in Retorts.

N. B.—STOP VALVES from three to thirty inches—at very low prices.

Plans, Specifications, and Estimates furnished.

KERR MURRAY MFG. CO.,

MANUFACTURERS OF

Single Lift and Telescopic

GASHOLDERS.

Built, 1884:

Altoona, Pa.....	Capacity, 160,000 cubic feet.
Pittsburgh, Pa.....	" 250,000 "
" ".....	" 220,000 "
Bellaire, Ohio.....	" 50,000 "
Youngstown, Ohio.....	" 60,000 "
Canton, ".....	" 60,000 "
Akron, ".....	" 80,000 "
Xenia, ".....	" 10,000 "
Adrian, Mich.....	" 65,000 "
Ypsilanti, Mich.....	" 25,000 "
Muskegon, ".....	" 70,000 "
South Bend, Ind.....	" 70,000 "
Anderson, ".....	" 20,000 "
Plainfield, ".....	" 10,000 "
Springfield, Illinois.....	" 100,000 "
Evanston, ".....	" 50,000 "
Freeport, ".....	" 35,000 "
Elgin, ".....	" 60,000 "
Sheboygan Wis.....	" 20,000 "
Key West Fla.....	" 10,000 "

Plans and estimates furnished for the erection of new and the rebuilding of old works. Address

Kerr Murray Mfg. Co.,

FORT WAYNE, IND.

CONTINENTAL WORKS.

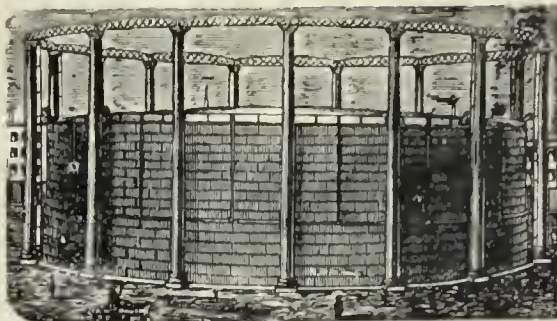

GASHOLDERS OF ANY MAGNITUDE.

T. F. ROWLAND, Proprietor,

GREENPOINT, BROOKLYN, N. Y.

ENGINEER AND MANUFACTURER OF

GAS-HOLDERS.

CONDENSERS, SCRUBBERS, VALVES,

PURIFIERS, RETORTS, and HY-

DRAULIC MAINS,

and all other articles connected with the Manufacture and Distribution of Gas. Plans and Specifications prepared and Proposals given for the necessary Plant for Lighting Cities, Towns, Mansions, and Manufactories.

H. RANSHAW, Prest. & Mangr. Wm. STACEY, Vice-Prest. T. H. BIRCH, Asst. Mangr. R. J. TARVIN, Sec. & Treas.

STACEY MFG. CO.,

MANUFACTURERS OF

Single and Telescopic Gasholders,

IRON ROOFS, BRIDGES, LAMP POSTS,

Water and Oil Tanks, Coal Elevator Cars,

COKE CRUSHERS, BENCH CASTINGS,

And all kinds of Wrought and Cast Iron Work used in the erection of Coal and Oil Gas Works. Rolling Mill Machinery and Heavy Castings a Specialty.

Foundry:

33, 35, 37 & 39 Mill Street.

Wrought Iron Works:

16, 18, 20, 22, 24 & 26 Ramsey Street:

Cincinnati, Ohio.

BARTLETT, HAYWARD & CO.,

Office, German & Calvert.

BALTIMORE, MD.

Works, Pratt & Scott.

PURIFIERS.

Roofs.

Bench Castings.

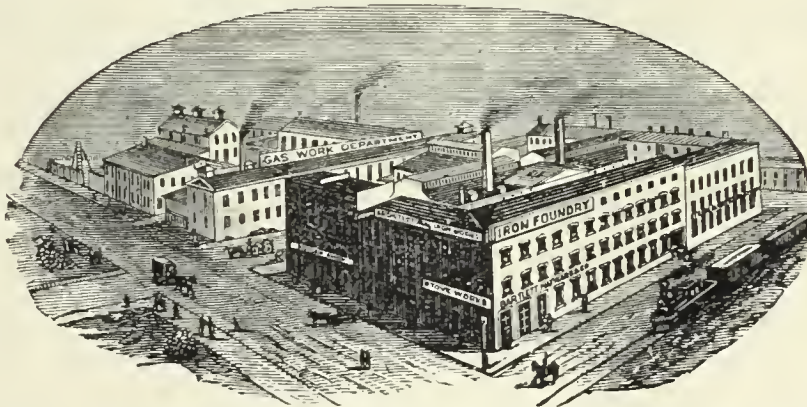

SCRUBBERS.

BOILERS.

CONDENSERS.

GASHOLDERS.

CONSTRUCTING ENGINEERS AND BUILDERS OF GAS WORKS.

1842. DEILY & FOWLER, 1886

Laurel Iron Works.

Address, No. 39 Laurel Street, Philadelphia, Pa.

MANUFACTURERS OF

GASHOLDERS,

Single or Telescopic, with Cast or Wrought Iron Guide Frames.

Holders Built Since 1881:

Scranton, Pa. (2d)	Hollidaysburg, Pa.	Jackson, Mich.	Montgomery, Ala.	New Castle, Pa.
West Point, N. Y.	Galveston, Texas (2d.)	Kalamazoo, Mich. (3d.)	Newport, R. I.	Long Island City, N. Y.
Fitchburgh, Mass.	Marlboro, Mass.	Glen Island, N. Y.	Portland, Oregon.	Macon, Ga.
New London, Conn.	Denver, Col.	Warren, Ohio.	Allegheny, Pa. (2d.)	York, Pa.
Derby, Conn.	Chicago, Ill. (West Side).	Bath, N. Y.	Atlanta, Ga. (2d.)	Chester, Pa.
Bridgeport, Conn.	Pittsburgh, Pa. (S. Side).	Lynn, Mass.	N.Y. City (Central Gas Co)	Hazleton, Pa. (2d.)
Allegheny, Pa. (1st.)	Pawtucket, R. I.	New Bedford, Mass.	Lynchburg, Va. (2d.)	Novelties Exhbn., Phila
St. Hyacinth, Can.	Brookline, Mass.	Waterbury, Conn.	Saylesville, R. I.	Staten Island, N. Y.
Norwalk, O.	Sherbrooke, Can.	Deseronto, Can.	Rondout, N. Y.	Saugerties, N. Y.
Brattleboro, V	Burlington, N. J. (2d.)	Hoosic Falls, N. Y. (2d.)	Atlantic City, N. J.	Clinton, Mass. (Lan. M)
Waltham, Mass. (2d.)	Bridgeton, N. J.	Bethlenem, Pa.	Augusta, Ga.	Chattanooga, Tenn.
West Chester, Pa.	Bay City, Mich.	Atlanta, Ga. (1st.)	Waltham, Mass. (2);	Galveston, Texas. (3d.
Baltimore, Md.	Erie, Pa.	Savannah, Ga.	Mahanoy City, Pa.	Omaha, Neb.

GAS COALS.

GAS ENRICHERS.

EXHAUSTERS.

JAMES D. PERKINS.

PERKINS & CO.,

F. SEAVERNS.

General Sales Agents for

The Youghioghenny River Coal Company's

OCEAN MINE YOUGHIOGHENY GAS COAL.

The Coal from the Ocean Mine (recently operated by Messrs. W. L. Scott & Co., of Erie, Pa.,) is now used by all the leading Gas Companies in the United States from Maine to Texas, and is recognized as *the only reliable Youghioghenny Gas Coal.* (See Map on p. 87 of this Journal, Feb. 16, 1885.)

P. O. Box 3695, **PERKINS & CO., 228 and 229 N. Y. Produce Exchange.** BEAVER STREET ENTRANCE. New York.

BRECKENRIDGE CANNEL,
OF KENTUCKY.

This colliery was re-opened in June of the present year, and the Cannel is now being delivered to thirty of the leading Gas Companies in this country. As an enricher ONE TON of this Cannel will do the work of two TONS of any other available Cannel. It can be delivered in parcels of one car load or more to any point in the United States or Canada. (See AMERICAN GAS LIGHT JOURNAL, June 16, '86, pp. 346-7.)

P. O. Box 3695, **PERKINS & CO., 228 and 229 N. Y. Produce Exchange** BEAVER STREET ENTRANCE. New York.

JAMES & WILLIAM WOOD,

Gas and Cannel Coal Contractors,

No. 40 St. Enoch Sq., Glasgow. No. 2 Talbot Court, London.

Proprietors of the **BATHVILLE COLLIERIES** (which produce the celebrated **BOGHEAD CANNEL**), Shields, Shieldmuir, Drumpeller, and other Collieries. This Firm offer

STANDARD CANNELS,

Unequaled as Gas Enrichers.

Analyses, prices, and all further information furnished on application to

Agency for U. S., Room 93, Nos. 2 & 4 Stone St., N.Y. City.

O. J. BENHAM, President. C. M. HIGGINS, Secretary. L. H. SEVERANCE, Treasurer.
The Forest City Naptha Co.,

REFINERS OF
Red Crown Brand
NAPTHA AND GASOLINES.

ALSO MANUFACTURERS OF
A Special Grade of Naptha for
Gas Companies

FOR ENRICHING COAL GAS.

Correspondence solicited.
No. 43 Euclid Avenue, Cleveland, Ohio.

To Gas Companies.

We make to order **CAP BURNERS** to burn any amount under a stated pressure. Send for samples.

Also, **SERVICE CLEANERS, DRIP PUMPS, and STREET MAIN PROVING APPARATUS.**

C. A. GEFROERER,
248 N. 8th Street, Phila., Pa.

The Wilbraham Gas Exhauster,

"BAKER SYSTEM,"

WITH ENGINE ATTACHED, ON SAME BED PLATE OR WITHOUT.

Best, Cheapest and Most Durable Exhauster known.

WILBRAHAM BROS.,

No. 2320 Frankford Avenue, Philadelphia, Pa.

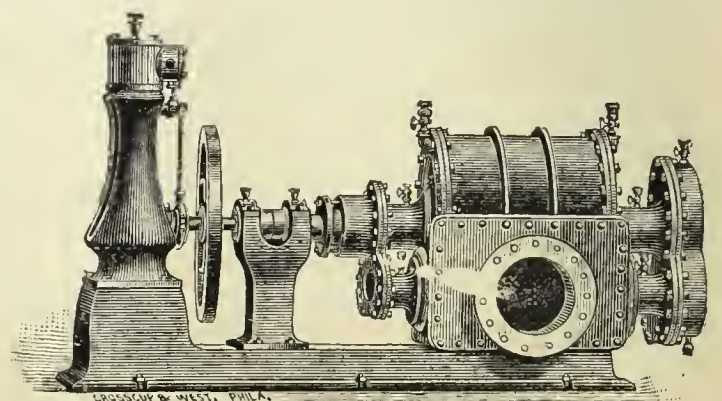

COKE CRUSHERS.

GAS COALS.

GAS COALS.

Newburgh Orrel Coal Co.,

MINERS AND SHIPPERS OF

Mountain Brook Steam and Smithing Coals,

AURORA, TYRCONNELL & PALATINE GAS COALS.

Foundry & Crushed Coke Shipped Direct from Ovens

Mines Situated at

Newburgh, Flemington & Fairmont, W.Va.

HOME OFFICE,

33 S. Gay St., Baltimore.

CHAS. MACKALL, Gen. Mangr.

CHAS. W. HAYS, Agent in New York,

Room 147, WASHINGTON BUILDING, No. 1 Broadway.

Shipping wharves at Locust Point, Baltimore.

THE DESPARD COAL COMPANY

OFFER THEIR SUPERIOR

DESPARD COAL

To Gas Light Companies and Manufacturers of Fire Clay Goods Throughout the Country.

ROUSSEL & HICKS, } AGENTS. { BANGS & HORTON, }
71 Broadway, N. Y. } { 16 Kilby St., Boston. }

Mines in Harrison Co., West Va. Wharves, Locust Point, Balt.

Company's Office, 15 German St., Baltimore, Md.

Among the consumers of Despard Coal we name: Manhattan Gas Light Co., N. Y.; Metropolitan Gas Light Co., N. Y.; Jersey City, (N. J.) Gas Light Co.; Washington (D. C.) Gas Light Co.; Portland (Maine) Gas Light Co. Reference to them is requested.

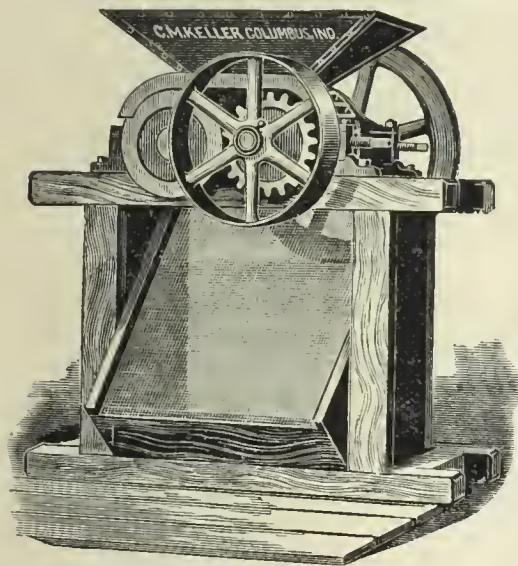

Keller's Adjustable Coke Crusher.

SIMPLE, STRONG, AND DURABLE.

C. M. Keller, Sec. & Supt. Gas Lt. & Coke Co. Columbus, Ind.

Correspondence Solicited.

GAS COMPANIES, ATTENTION!

Increase the demand for Coke by using the

Star Coke Breaker.

SIMPLE, CHEAP, DURABLE. EASILY SHARPENED BY ANY BLACKSMITH.

B. J. ALLEN, Newark Gas Co., Newark, N.J.

King's Treatise on Coal Gas.

The most complete work on Coal Gas ever published.

Three Vols. Bound, \$30.

A. M. CALLENDER & CO., 42 Pine St., N. Y.

THE PENN GAS COAL CO.

OFFER THEIR

Coal, Carefully Screened & Prepared for Gas Purposes.

Their Property is located in the Youghiogheny Coal Basin, near Irwin and Penn Stations on the Pennsylvania Railroad, and on the Youghiogheny River.

Principal Office:

209 SOUTH THIRD STREET, PHILA., PA.

Points of Shipment:

Pennsylvania Railroad Piers; Greenwich Wharves, Delaware River; Pier No. 1 (Lower Side), South Amboy, N. J.

Chesapeake & Ohio Railway Coal Agency,

FOR THE SALE OF THE

Superior Kanawha Gas Coals, Cannelton Cannel, Also, SPLINT AND STEAM COALS.

From the Kanawha and New River Regions, on the line of the Chesapeake & Ohio R'way.

C. B. ORCUTT, Sales Agent. | OFFICE, 150 BROADWAY, N. Y.

FRANCIS H. JACKSON, Prest. EDMUND H. MCCULLOUGH, V.-Prest. CHAS. F. GODSHALL, Treas. H. C. ADAMS, Sec.

THE WESTMORELAND COAL CO.

Chartered 1854.

Mines situated on the Pennsylvania and the Baltimore and Ohio Railroads, in Westmoreland County, Penn.

POINTS OF SHIPMENT:

PHILADELPHIA, BALTIMORE, SOUTH AMBOY, N. J., WATKINS (SENECA LAKE), N. Y.

Since the commencement of operations by this Company its well-known Coal has been largely used by the Gas Companies of New England and the Middle States, and its character is established as having no superior in gas giving qualities, and in freedom from sulphur and other impurities.

Principal Office, 224 South 3d St., Phila., Pa.

A. M. SCOTT, PRESIDENT. A. DEMPSTER, C.E., SECRETARY. W. K. GILLESPIE, TREASURER.

MONONGAHELA AND PETERS CREEK GAS COAL CO.,

PRODUCERS OF

Coal Bluff Gas Coal.

MINES LOCATED ON THE MONONGAHELA DIVISION OF THE PENNSYLVANIA RR., IN THE CENTRAL PORTION OF THE PITTSBURGH COAL FIELD.

Points of Shipment—Buffalo, Cleveland, Erie, Chicago, New Orleans.

Since the introduction of Coal Bluff Gas Coal it has taken rank among the few first-class Gas Coals, and acknowledges no superior in gas-giving qualities, ease of working, quality of coke, and freedom from impurities.

General Eastern Agents, ANDREW LANGDON & CO., Buffalo, N. Y.

General Western Agents, ANDREW LANGDON & CO., Chicago, Ill.

Milwaukee Agents, F. R. BUELL & CO., - - - Milwaukee, Wis.

General Office, 43 Sixth Ave., Pittsburgh, Pa.

GAS METERS.

GAS METERS.

GAS METERS.



INTERNATIONAL--1876--EXHIBITION.

The U. S. Centennial Commission

HAVE DECREED AN AWARD TO

HARRIS, GRIFFIN & CO.,

Twelfth and Brown Streets, Philadelphia, Pa. No. 49 Dey Street, N. Y. City, and No. 75 North Clinton Street, Chicago, Ill.

FOR THE FOLLOWING REASONS :

The Exhibit consists of a Series of METERS from the Largest Size Station Meters for the use of the MANUFACTURE OF GAS, to those for the use of the ORDINARY CONSUMER. The Instruments are WELL MADE, RELIABLE as to INDICATION, and embody a number of sundry improvements which, with the general character of the Exhibit, entitle the whole to commendation.

Attest—J. L. CAMPBELL,
Secretary, pro-tem.

Signed—A. T. GOSHORN,
Director General

J. R. HAWLEY,
President



Dry Gas Meter.

With 39 years' experience and the best facilities for manufacturing, is enabled to furnish reliable work and answer orders promptly.

NATHANIEL TUFTS,*No. 153 Franklin Street, Boston, Mass.,*

MANUFACTURER OF

DRY GAS METERS.

Station Meters of any Capacity.

Test and Experimental Meters, Pressure Registers, Pressure Gauges,
Pressure and Vacuum Gauges.**METER PROVERS, PHOTOMETERS, STREET LANTERNS, ETC., ETC.**

Patent Cluster Lanterns for Street Illumination.

SCIENTIFIC BOOKS.

We are prepared to furnish to Gas Managers, and others interested in the topics treated of, the following books, at prices named:

KING'S TREATISE ON THE MANUFACTURE OF COAL GAS. Three vols.; \$10 per vol.	PRACTICAL TREATISE ON HEAT, by THOMAS BOX. Second edition. \$5.	THE GAS MANAGER IN THE LABORATORY, by a Practical Student. 8vo., Cloth. \$1.50.
GAS MANUFACTURE, by WILLIAM RICHARDS. 4to., with numerous Engravings and Plates, in Cloth binding. \$12.	GAS WORKS—THEIR ARRANGEMENT, CONSTRUCTION, PLANT, AND MACHINERY. \$8.	THE DOMESTIC USES OF COAL GAS, AS APPLIED TO LIGHTING, by W. SUGG. \$1.40.
THE GAS ANALYST'S MANUAL, by F. W. HARTLEY. \$2.50.	COAL; ITS HISTORY AND USE, by PROF. THORPE. \$3.50.	DISTILLATION OF COAL TAR AND AMMONIACAL LIQUOR by GEO. LUNGE. \$8.50.
TECHNICAL GAS ANALYSIS. \$2.80.	THE GAS WORKS OF LONDON, by COLBURN. 60 cents.	A TREATISE ON THE COMPARATIVE COMMERCIAL VALUES OF GAS COALS AND CANNELS, by D. A. GRAHAM 8vo., Cloth. \$3.
GAS MANAGER'S HANDBOOK, by THOS. NEWBIGGING. \$4.80.	THE GAS FITTER'S GUIDE, Showing the Principles and Practice of Lighting with Coal Gas, by JOHN ELDREDGE. 40 cents.	GAS AS A SOURCE OF LIGHT, HEAT, AND POWER, by C. J. R. HUMPHREYS. 10 cents.
GAS CONSUMER'S GUIDE. \$1.	GAS WORKS, AND MANUFACTURING COAL GAS, HUGHES. \$2.20.	GAS COMPANIES DIRECTORY. \$10.
A GUIDE TO GAS LIGHTING. 40 cents.	THE MANAGEMENT OF SMALL GAS WORKS, by C. J. R. HUMPHREYS. \$1.	GAS VERSUS ELECTRIC LIGHT. 50 cents.
GAS MEASUREMENT AND GAS METER TESTING, by F. W. HARTLEY. \$1.60.	MANUAL FOR GAS ENGINEERING STUDENTS, by D. LEE, 40 cents.	PURIFICATION OF COAL GAS, by R. P. SPICE. 8vo. \$3.
GAS CONSUMER'S HANDBOOK, by WILLIAM RICHARDS, C.E.; 18mo., Sewed. 20 cents.	HOW TO MANAGE GAS, by F. WILKINS. Paper. 20 cents.	
A PRACTICAL TREATISE ON GAS AND VENTILATION with Special Relation to Illuminating, Heating, and Cooking by Gas, by E. E. PERKINS. \$1.25.		

The above will be forwarded by express, upon receipt of price. We take especial pains in securing and forwarding any other Works that may be desired, upon receipt of order. All remittances should be made by check, draft, or post office money order.

A. M. CALLENDER & CO., No. 42 Pine Street, New York.**KING'S TREATISE ON COAL GAS.**

The most complete work on Coal Gas ever published. Three vols., bound \$30

A. M. CALLENDER & CO., No. 42 Pine Street, New York.

GAS METERS.

GAS METERS.

GAS METERS.

T. C. HOPPER, Pres. G. J. McGOURKEY, Vice-Pres. (New York). WM. N. MILSTED, Gen. Supt. & Treas. (New York). WM. H. DOWN, Sec.

AMERICAN METER COMPANY,

WET AND DRY GAS METERS.

PRESSURE REGISTERS.

METER PROVERS.

STATION METERS.

PRESSURE & VACUUM REGISTERS.

PORTABLE TEST METERS.

EXHAUSTER GOVERNORS.

PRESSURE & VACUUM GAUGES.

EXPERIMENTAL METERS.

DRY CENTRE VALVES.

CRESSON GAS REGULATORS.

AMMONIA TEST METERS.

GOVERNORS FOR GAS WORKS.

MARSLAND WATER METERS.

BAR AND JET PHOTOMETERS.

Manufactories:

512 W. 22d St., N. Y.
Arch & 22d Sts., Phila.

GAS STOVES,

SUGG'S "STANDARD" ARGAND BURNERS,
SUGG'S ILLUMINATING POWER METER,
Wet Meters, with Lizar's "Invariable Measuring" Drum.

Agencies:

177 Elm Street, Cincinnati.
214 & 216 N. Wells Street, Chicago.
810 North Second Street, St. Louis.
122 & 124 Sutter St., San Francisco.

HELME & McILHENNY,

(Successors to Harris & Brother. Established 1848.)

GAS METER MANUFACTURERS,

CONTINUE AS HERETOFORE AT THE OLD ESTABLISHMENT.

Nos. 1339 to 1349 Cherry Street, Philadelphia, Pa.,

To Manufacture Wet and Dry Gas Meters, Station Meters, Experimental Meters, Meter Provers, Center Seals, Pressure Registers

GOVERNORS, INDICATORS, PHOTOMETERS, & ALL OTHER KINDS OF APPARATUS FOR USE IN GAS WORKS.

From our long practical experience of the business, and from our personal supervision of all work, we can guarantee all orders to be executed promptly and in every respect satisfactorily.

WM. WALLACE GOODWIN, Prest. and Treas.

WM. H. MERRICK, V.-Prest.

S. L. JONES, Sec.

S. V. MERRICK, Supt.

THE GOODWIN GAS STOVE AND METER COMPANY,

Successors to W. W. GOODWIN & CO.

1012, 1014 and 1016 Filbert St., Phila., Pa.

142 Chambers St., New York.

76 Dearborn St., Chicago, Ill.

WALDO BROS., Agents, 88 Water St., Boston.

MANUFACTURERS OF THE "SUN DIAL" GAS STOVES, FOR COOKING AND HEATING PURPOSES.

Dry and Wet GAS METERS, Station Meters (Square, Cylindrical or in Staves) Glazed Meters, King's and Sugg's Experimental Meters, Lamp Post Meters, Etc., Etc., Meter Provers (sizes 2, 5 and 10 feet), Pressure Gauges of all kinds, Pressure Registers, Pressure and Vacuum Registers, Pressure Indicators (sizes 4 inch, 6 inch and 9 inch), King's Pressure and Vacuum Gauges, Dry and Wet Centre Seals, Dry and Wet Governors, Exhauster Governors, Photometers of all descriptions. Letheby's Sulphur and Ammonia Test Apparatus complete—also Testing and Chemical Apparatus of all kinds, and of the most perfect description, for all purposes relating to Gas.

GOODWIN'S IMPROVED LOWE'S JET PHOTOMETER.

Agents for Bray's Patent Gas Burners and Lanterns.

Special attention to repairs of Meters, and all apparatus connected with the business.
All work guaranteed first class in every particular, and orders filled promptly.

G. B. EDWARDS, Mang'r, New York.
E. H. B. TWINING, Mang'r, Chicago.
Represented by A. B. STANNARD.

D. McDONALD & CO.,

GAS METER MANUFACTURERS.

(Established 1854.)

51 Lancaster St., Albany, N. Y. 34 & 36 West Monroe St., Chicago, Ill.

STATION METERS, EXPERIMENTAL METERS, METER PROVERS, PRESSURE & VACUUM REGISTERS, PRESSURE GAUGES, ETC.

Also STAR GAS STOVES, RANGES, and HEATING STOVES.

We use only the very best materials, and employ the most skilled labor, and by our long experience (29 years) and personal supervision of every detail, we feel justified in assuring the public that our goods will give perfect satisfaction. Every Meter emanating from our establishment will bear the State Inspector's BADGE, and will be fully warranted by us. Our Annual and Calendar will be sent to Gas Companies upon application.

GAS STOVES.

GAS STOVES.

GAS STOVES.

THE GOODWIN GAS STOVE AND METER CO.,

1012-18 Filbert St., Phila., 142 Chambers St., N. Y., 76 Dearborn St., Chicago.

Agents, WALDO BROTHERS, 88 Water Street, Boston.

WM. W. GOODWIN, PRES. & TREAS.
W. H. MERRICK, VICE-PRES.
LEWIS JONES, SEC.
SAMUEL V. MERRICK, SUPT.

SOLE MANUFACTURERS OF THE

G. B. EDWARDS, Mang'r, N. Y.
E. H. B. TWINING, Mang'r, Chicago.
Represented by A. B. STANNARD.

"SUN DIAL" GAS STOVES

The Most Economical, Efficient, and Durable Gas Stove Made.

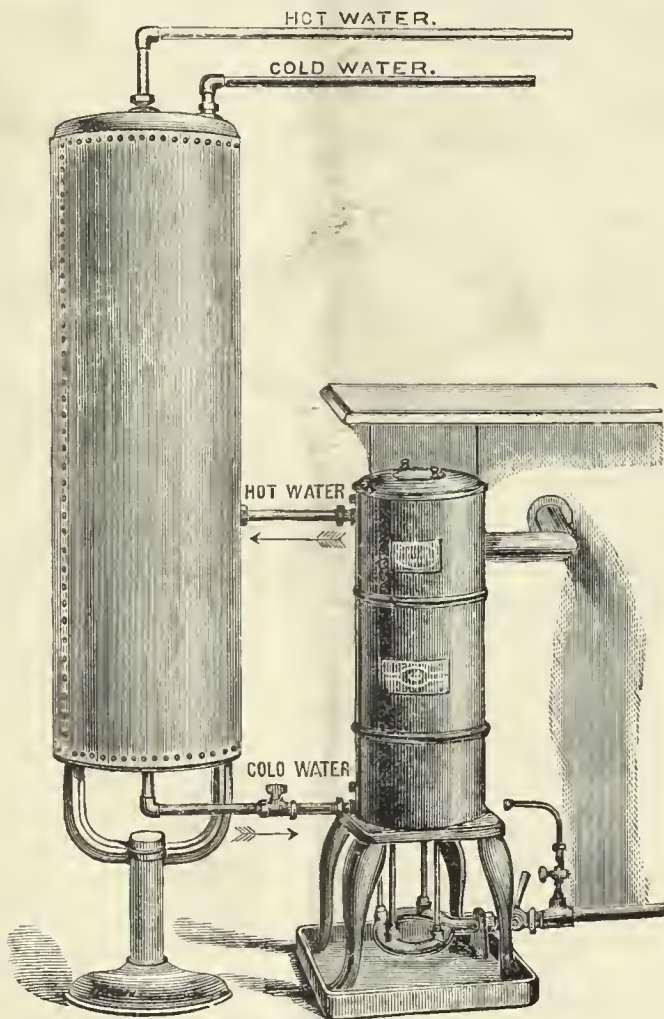

I.—Safety Hot Water Generator and Boiler.

Safety Hot Water Generator and Boiler.

Cut I. represents our Safety Gas Hot Water Generator and Boiler, arranged for home use. This most easy, quick, and economical way of preparing a warm bath, or for heating water for any domestic purpose, entirely supersedes any necessity for the use of ranges or stoves—a great comfort, particularly in hot weather. The boiler being self-filling, as the hot water is drawn off, can never become empty, thus preventing the possibility of any accident.

We beg to call attention to the cast iron pan which is now attached to the legs of the Generator (see illustration). This is to catch the drippings from the Coil, which many persons suppose come from a leak, when in fact they are produced by condensation. This condensation is caused by the hot flame coming in contact with the coil filled with cold water.

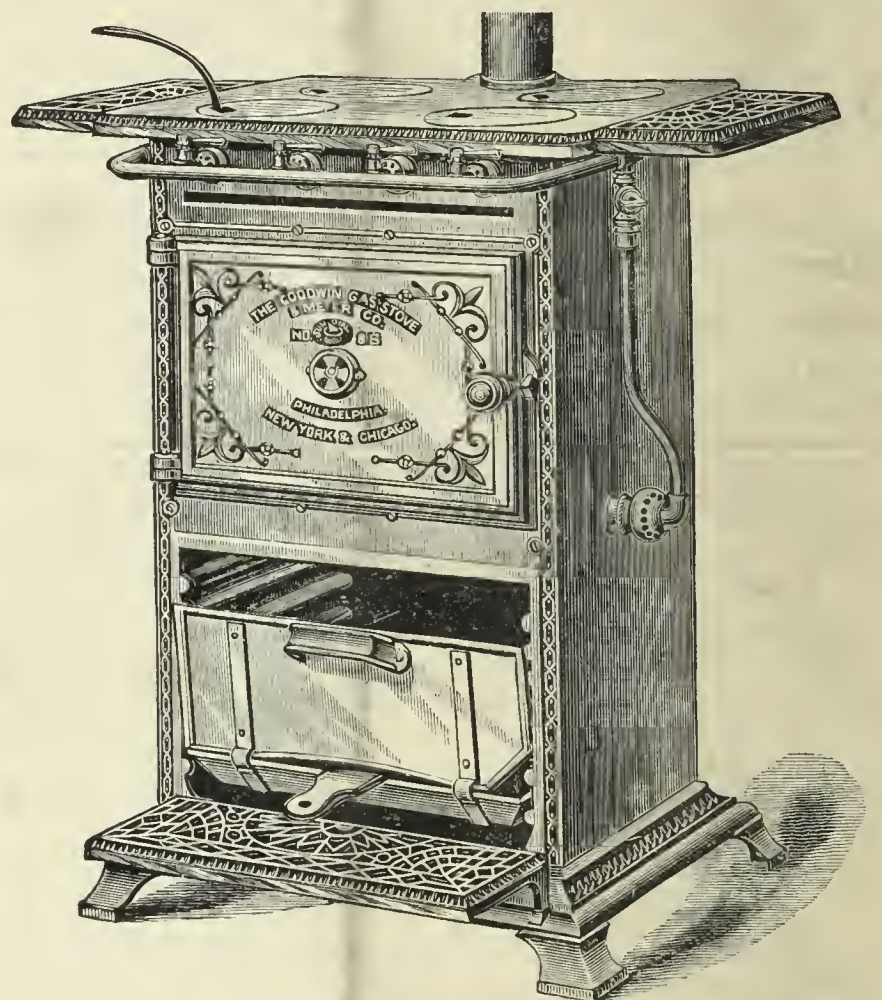

II.—Gas Cooking Stove No. 8 B.

New Style Gas Cooking Stove.

Cut II. represents our New Style Cooking Stove. As will be seen, it has an ornamented cast iron base and front, and extension shelves. The oven burner, which is atmospheric (unless otherwise ordered), is of an entirely new and improved pattern (patent applied for). The ovens are of greater capacity than those of the old style. The top, in conjunction with the outlet pipe, is designed to carry off all products of combustion; hence the outlet pipe must be connected with a flue, or the stove will not work properly.

This Stove has 4 boiling burners on top of hot plate. All fittings are nickel plated. We are making this style of Cooking Stove in the following sizes—viz., No. 7 B, No. 8 B, No. 9 B, and No. 10 B.

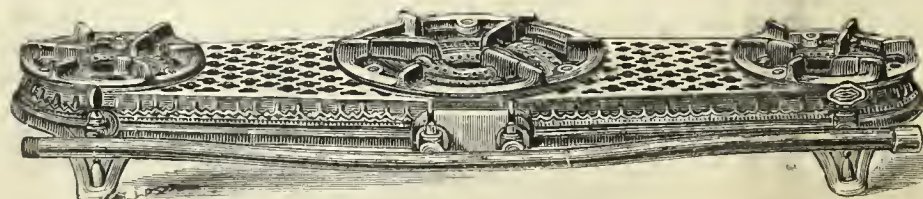

III.—Improved Hot Plate, No. 108.

New Style Hot Plates.

Cut III. represents our New Style of Hot Plates, of which we are making No. 106 (two small boiling burners), No. 107 (two medium sized boiling burners), and No. 108 (two medium and one large boiling burner). See new Catalogue and Price List for further particulars.

THE AMERICAN

GAS LIGHT JOURNAL

RODMAN & KENNY, N.Y.

PUBLISHING OFFICE No. 42 PINE STREET

DEVOTED TO THE INTERESTS OF ILLUMINATION, VENTILATION, WATER SUPPLY AND DISTRIBUTION, & GENERAL SCIENCE.

VOLUME XLVI.—No. 4. }
Whole No. 661.

NEW YORK, WEDNESDAY, FEBRUARY 16, 1887.

{ \$3 PER ANNUM,
IN ADVANCE.

A. M. CALLENDER & CO., Proprietors. C. E. SANDERSON, Manager.
JOS. R. THOMAS, C.E., Editor. T. J. CUNNINGHAM, Asst. Editor.

ENTERED AT THE POST OFFICE AT NEW YORK, N. Y.
AS SECOND CLASS MATTER.

Published on the 2d and 16th of each month, at No. 42 Pine Street, N. Y.

Terms of Subscription, Including Postage.—For the United States and Canada, \$3 per annum. European countries, \$3.50 (15 shillings—18 francs). All payments to be made in advance. Single copies, 15 cents.

Remittances should be made either by post-office order, registered letter, or bank draft on New York, payable to the order of A. M. Callender & Co.

Correspondence.—Wishing to make this JOURNAL a gazette of intelligent discussion to those of our readers who may wish to gain or give information on the subjects to which its columns are devoted, correspondence is solicited for publication from all who make the study of those subjects a pleasure or a profession.

The American News Company, Nos. 39 and 41 Chambers street, New York, are agents for this JOURNAL. Newsdealers will send orders to them.

Collections are invariably made directly from this office, for subscriptions, advertisements, etc. We have agents to solicit the same, but they are not authorized to receipt for money.

Books.—We will forward by express, at publisher's lowest rates, any book—scientific or otherwise—to any address in the United States or Canada. No books will be sent C. O. D.

CONTENTS.

An Asterisk (*) denotes an illustrated article.

OFFICIAL NOTICE—

Ohio Gas Light Association..... 97

EDITORIALS—

Varying Phases of the Lighting Question in Brooklyn, N. Y..... 97
Will New York Have a Gas Commission?..... 98
The Annual Report of the Massachusetts Commissioners..... 98
The Storage Battery, by Prest. Henry Morton..... 98
New Works of the South Metropolitan Gas Company, at East Greenwich, London, by Norton H. Humphrys..... 102
Senator Worth's Bill to Create a Board of Gas Commissioners for the State of New York..... 103
Rules and Regulations Relating to the Use of Gas Machines..... 104
*The Economic Gas Soldering Iron..... 105
*Pipe Wrench Converter Attachment..... 105
Notes from the West, by Retort..... 106

ITEMS OF INTEREST FROM VARIOUS LOCALITIES..... 106

In Charge at Winfield, Kas.—In Re the Philadelphia Gas Works—To Improve the Plant—Ordered to Stop the Leaks—Springfield (Mo.) Wheels into Line—Cheaper Gas for St. Paul, Minn.—Lost and Found—New Gas Company—To be Absorbed—Annual Election at Delaware, Ohio—Price Charged for "Carbon Points"—Death of Mr. Chris. Olsen—Change of Management—A Queer Explosion—Not Quite so Doleful—Annual Election—Something from Paducah, Ky.—Furbishing Up at Kansas City, Mo.—Re-elected—The "Exclusive Franchise" was Sustained—New Holder for the Pittsburgh (Pa.) Works—Charter Extended—Ordinances, and no Mistake—Bro. Prichard in Trouble—Annual Elections—Cut Down—Almost Ready for Business—Verdict for the Plaintiff—The Cowboy Section Could not Ask for More—Electric Light in Theaters—The Old Pittsfield (Mass.) Gas Company—What Bro. Hunt is Doing at Morristown, N. J.—Annual Meeting of the San Francisco (Cal.) Gas Company—Wants an Electric Light Plant—New Gas Company—Number of Public Lamps at Norristown, Pa.—Repairing the Breaks—Deprived of their Gas—No One Doubts it in this Establishment.

CORRESPONDENCE—

"A. S." is not Convinced..... 109
The Market for Gas Securities..... 110

[OFFICIAL NOTICE.]

Ohio Gas Light Association.

OFFICE OF SECRETARY, COLUMBUS, OHIO, Feb. 10, 1887.

To the Members of the Association:—The Third Annual Meeting of the Ohio Gas Light Association will be held in Dayton, Ohio, on the 16th and 17th of March, next.

As a stimulus to a good attendance, and to add interest to the meeting, as well as to obtain the best views of the gas men of the State upon a vexed subject, the President of the Association offers a reward of \$25 for the best, and \$10 for the next best paper upon the following subject—the only condition being that there shall be not less than three papers presented thereon—
"How Shall We Get Rid of Naphthaline Crystals about the Works, and Still Maintain High Heats?"

Let every gas man in the State not only make his arrangements to attend our Dayton meeting, and also at least come prepared to participate in the discussion of the subjects named in circular list, published in the JOURNAL, issue of January 17th.

IRVIN BUTTERWORTH, Secy.

VARYING PHASES OF THE LIGHTING QUESTION IN BROOKLYN, N. Y.

The city of Brooklyn, at least in the matter of those things which pertain to certain of her artificial light supply industries, has occupied a prominent place of late in the "eyes of the State," the visual organs this time being located at Albany, or the region which now holds possession of the Empire State's lawmakers. Not such a great while ago our item columns contained allusion to the profuse manner in which Brooklyn was being served with "half arcs" for public lighting; and in fact we do not think that a more extravagant supply of this particular sort of illumination (not even excepting Buffalo) was or ever will be witnessed in any city on the face of the globe. The quagmires of Gowanus, the purlieus of Red Hook Point, the bleak hills of the eastern slope—sometimes called "Crow Hill"—and the odoriferous region that approximates to the boundaries of Long Island City, all bask beneath the effulgence of the sparkle from betwixt the carbon points. Of course, the other sections of the City of Churches, or those wherein the business man displays his wares, or where the "upper circles" dwell within their ostentatious habitations, were not slighted in the generous allotment of the carbon points. No; on rich and poor alike the light of the arc descends! And that uninvincible action proves the democracy of those who furnish the current—and collect their pay therefor from the common treasury. Indeed, in our former reference to this peculiarity in the Brooklyn situation, we ventured the prediction that the law might some day or another cause trouble to the controllers and abettors of our sister city's electric lighting, and that interference came sooner than we thought. The January Grand Jury attempted to probe the matter, and while they did not present a formal indictment against any of the individuals who comprise the electrical coterie, they did in general terms arraign those worthies severely, the arraignment taking the form of an open letter, so to speak. Perhaps a set presentment would have been effected were it not for the "legal advice" given by the present District Attorney, who, it may be explained, is in thorough accord with the political party now in power; and it may be further said that some of the leaders of that political party are owners of the electric lighting com-

panies. At any rate, the Grand Jury's arraignment appears to have had weight enough with the Albany Solons to cause the latter to appoint a select committee, with power to send for persons, papers, etc., that has been instructed to investigate about every municipal department in the City of Churches. Of course, we are not blind to the fact that political partisanship is at the bottom of the Albany action; for one set of politicians who are "in" at Albany, but who are "out" at Brooklyn, seek to add the latter city to their list of possessions. Speaking frankly, we do not think the "investigators" will find that much corruption exists in the present management of Brooklyn's civic affairs, save in the single instance of the doings of those in charge of the public lighting. In any event, admitting that every arc light now in action was honestly contracted for, if corruption or collusion is not shown to exist or to have existed in the public lighting department, it is notoriously patent that extravagance and prodigality, of the most extensive nature, have ruled in connection with the electric lighting contracts. Lavishness may not be held to be criminal; but those officials who are prodigal in their disposal of the taxpayers' contributions ought to receive a stern reminder that incompetence can dissipate the funds about as thoroughly as the act of a speculator or defaulter.

Brooklyn's gas companies are also in a state of mind over what the future has in store for them. We would like to be able to say a good word for them; but the best that might be urged in their favor would at least constitute a lame defence. The greed of the past, added to the inanity of their course in regard to the early efforts of the Standard Oil Company's gas ring, now comes home with double force. Indeed, when an able man like ex-Senator E. B. Thomas, is obliged to resort to the specious style of argument employed by him, on the occasion of an appeal before the Committee of the Senate—Mr. Thomas represented the case of the Brooklyn gas companies—who were considering the Griswold bill to lower the Brooklyn gas rate to \$1.50 per thousand cubic feet, we must condole with his employers. However, the Senate seems disposed to deal with the Brooklyn gas suppliers in a gentle mood, for the Committee have reported favorably a measure which, if finally passed, will place the rate for gas in Brooklyn at \$1.60 per thousand, and every gas maker in the country will concede that figure ought to be satisfactory. Of course, we do not concede the right of the Legislature to interfere in the matter at all. We have all along contended that the courts would upset such interference, and we hold to that view now. Nevertheless, the Legislature has interfered, and so the Brooklyn companies must bow to that which is, and be satisfied with a slice when they cannot hope for the loaf. If common sense had guided them in the past the loaf would still be theirs.

WILL NEW YORK HAVE A GAS COMMISSION?

During the discussion that followed the presentation of Mr. Ramsdell's paper on "Gas Commissions," read at the Philadelphia meeting last fall, Messrs. McDougall, of Hornellsville, and McDonald, of Albany, predicted that legislation to provide for the establishment of a gas commission in the State of New York would undoubtedly take place next winter. "Next winter" having in the natural order of things become "this winter," we also note that the predictions made in Philadelphia are now verified. Elsewhere in our columns will be found the text of the Worth commission bill, which strikes us as being decidedly loose in its provisions, although, in the main, it may prove acceptable to the gas men of the State. But Senator Worth is not alone in the field, since one or two other Solons have presented similar bills. Perhaps the most important of these latter is the measure proposed in the Assembly by Mr. Erwin. The Erwin bill places the commissioners' compensation at \$4,000 each per annum; provides for three commissioners; places their term of office at four years; and restricts the maximum annual total expense to \$50,000. The Erwin proposal, it is said, meets with the approval of Governor Hill. However, all these propositions are inchoate; and, no doubt, many changes will be made in them ere their fate is finally determined.

THE ANNUAL REPORT OF THE MASSACHUSETTS COMMISSIONERS.

The Second Annual Report of the Massachusetts Gas Commissioners has been printed, and it may be said to form a complete compendium of the gas business of that State. He who, having studied its pages, cannot obtain therefrom a thorough knowledge of the gas business of the Bay State, must be dull indeed.

Some time ago we believe it was said the principal trouble connected with the official duties of the commissioners was that these gentlemen had really so little to do; but we opine that the clerk to the Board, Mr. Walter S. Allen, does not share in such belief. The gas companies may also be placed in line with Clerk Allen's opinions in regard to the item of labor, for the queries which had to be answered were numerous and perplexing. We expect, from time to time, to furnish our readers with copious extracts from the report. Many surprising, instructive and entertaining matters are outlined in its pages.

[An address made to the Society of Gas Lighting (at a session held in the Stevens Institute of Technology, Hoboken, N. J. Thursday evening, Feb. 3d) by the President of the Institute. Especially reported for the JOURNAL, and revised for publication by the author.]

The Storage Battery.

By PRESIDENT HENRY MORTON.

I think some of the members of this Society may remember that about nine years ago I had the pleasure of addressing them, in connection with others, on the subject of electric lighting,* then beginning a somewhat sprightly infancy. The developments made by Mr. Edison were exciting attention, and he had been promising many remarkable things. At that time, among the points made, as illustrating that the progress in electric lighting would not be so extremely rapid as Mr. Edison or his friends indicated when they proposed to light New York within six weeks, I stated that what would probably restrain this very rapid progress was that in electricity there was then known no method of storage, by reason of which work could be done in preparing the electric energy at one time, and the prepared electricity be used at a subsequent period.

Now, this evening, I propose chiefly to draw your attention to what has been done in that particular direction since then, and will begin by alluding, in a few words, to something that was done at an earlier time. In the first place, it is manifest that some sort of storage of electricity is of very great importance. You all know how inconvenient it would be if a gas works had to be run, in which you made the gas hour by hour as it was required; how necessary it would be to have an extremely large plant, and to have its workings unusually precise and certain; in fact, it would be almost beyond possibility to make the output at specific times, and yet comply with more or less irregular demands. The same thing, of course, holds true with electricity; and one of the drawbacks and causes of increased expense in running electric apparatus has come, and will come for a long time yet, from the impossibility of storing satisfactorily this energy. As the result of this a plant has to be put up which will be able at one time to supply the maximum number of burners, and such a plant will, as things generally run, be used to its maximum capacity only for a very few hours out of the twenty-four. I think that statistics showed a year or two ago that the Edison plant was used to its full capacity on an average only about four hours out of the twenty-four, and therefore it was wasting itself, as it were, by not being used during the very much greater part of the time.

Another reason why a storage is desirable is the difficulty that exists, more or less, in keeping a perfectly regular supply of electricity—that is, that there should be no fluctuations. Great improvements have been made in machinery for that purpose, and great perfection has been already attained; but still this great precision is only attainable by extreme care and accuracy in the machinery and the running of it, all of which, of course, is a source of expense.

Now, in the case of electricity, up to the present time no *direct* method of storage can be suggested or has been approached. Of course, as you all know, electricity can be, to a certain degree, stored in a Leyden jar, and we can put a little bit into a condenser; but when we compare the quantities that can be so stored with the quantity used in an electric light we see how inadequate they are. If we had Leyden jars sufficient to fill this entire room they would not hold electricity enough to run one of these lamps for five minutes, and the cost of a condenser which would be capable of generating sufficient electricity to run one of these lights for an evening would be perhaps half a million of dollars. Therefore any such thing is out of the question.

So we are left to the method of storage of an indirect kind—that is, a storage of electricity by a transformation or conversion of energy. In that regard the storage of electricity which has been so far secured is precisely parallel with the storage of sunlight which nature has provided in the development of vegetable life. For example, the sun's rays fall upon a tree; the tree grows; wood substance is developed, and that wood afterward can be burned, and we can get from it energy in the form of light and heat, which is equivalent to and is in a sense the very same energy which fell upon it as sunlight. It has not been sunlight and sunheat during the intermediate time. It is turned from solar or light energy into chemical or potential energy in the plant, and then back again. The same thing is true of the energy by which we live and move—namely, the energy derived from our food. The energy that has come from the sun and has gone into the growing plant which the animal feeds upon has become chemical energy. If a plant is eaten by an animal this energy suffers another chemical change, but the carbon, hydrogen, etc., in the plant is that portion of the animal's food which maintains a warm temperature in its body and enables the animal to move and perform work requiring the expenditure of energy.

Now, in all these cases the chemical action, roughly described, is of this

* A Lecture delivered by President Henry Morton, before the American Gas Light Association, at the Stevens Institute, Hoboken, N. J., on Oct., 17, 1878. For report of same see JOURNAL, Vol. XXX., issue of Jan 2-16, and Feb. 2-16, 1878.

nature. There exists in the air a great quantity of carbonic acid, consisting of atoms of carbon and oxygen which are close together. The particles are as near to each other as they can get, and therefore they have lost all power of developing energy or doing work. As the sunlight falls upon the plant and makes it grow, that growth consists chiefly in a separation of the carbon and oxygen constituting the carbonic acid of the air. Of course there is a separation of the elements of water; but I may leave that out for the present for simplicity of expression. The carbon and oxygen are separated. The carbon is packed away in wood tissue, and the oxygen is preserved in the atmosphere. The supply of oxygen in the atmosphere is kept up, to a certain extent, by the growth of the plants.

The growing plant, then, gets from the sun the power of decomposing carbonic acid and pulling apart these two things—carbon and oxygen—which existed in it. Then those two things, when they come together again in the burning of the log, develop vibration of light and heat, and we get energy again, which may be used to run a steam engine or to give us light and heat. Also, when the carbon and its compounds are introduced into the system by digestion, and come to exist in the blood, they unite with the oxygen inhaled through the lungs; and again under these circumstances we get energy from this union of these elements, and we are kept warm and given the power of exerting our muscles and our brains.

Thus you see what sort of an action takes place when the sunlight, acting upon the growing plant, decomposes carbonic acid, and so stores up energy by separating things which were before combined, and which, when they reunite, will develop any form of energy that may be required, according to the conditions under which the reunion takes place. This is the general doctrine and theory of energy now universally accepted in relation to these things.

Now, the method which exists in what we call the storage battery for the preservation of electrical energy is of a precisely parallel character. (At this point Prest. Morton exhibited a small battery.) In this battery, whose structure I will describe more fully by and by, we have, to begin with, plates of lead with an acid solution between them. We pass an electric current through this (indicating), and the acid solution is decomposed. Taking the principal and neglecting the less important parts of the action, so as not to complicate the statement, we have a separation of oxygen from hydrogen, which exist combined together in the solution. The electric current in the battery, like the sunlight on the tree, causes the plates of the battery to separate these two elements. The oxygen draws to and combines with one plate; the hydrogen goes to the other plate and either remains there as such, absorbed in the plate, or remains there in effect by securing a decomposition of an oxide previously existing in the plate, and depositing the metal, lead, as a representative of what we may call the metal, hydrogen.

Here, again, we have a dead compound—the acid solution—whose particles are all so close together that they cannot move toward each other and obey the chemical attraction which draws them toward each other, and are therefore, without any power or energy. But when now, the electric current passing through the apparatus, it separates this compound and puts the oxygen on one side and the hydrogen, in effect, on the other. That having been done, we can at any future time take that arrangement of plates with the oxygen on one side and the hydrogen on the other, and, by making a metallic connection between the ends, cause the oxygen and hydrogen to reunite under conditions favorable for developing electric energy. When substances unite chemically they may develop any kind of energy according to the structure in which their reunion takes place. A chemical reunion in the body of a man will develop muscular energy causing motion, and heat energy, and brain energy. That same combination, taking place in a furnace, will develop heat energy and light energy. That same combination being, in fact, a union of the same substances, taking place in the arrangement which we call a galvanic battery will develop electric energy. Chemical combination, in other words, is capable of developing any sort of energy, the kind depending upon the mechanism in which the reunion takes place.

Here, then, is the principle involved in the storage of electricity. The term in one sense, of course, is a very inappropriate one. If it leads us to think that electricity, as such, is packed away like hay in a bale, it would be entirely misleading; but not so if we look upon it as the preservation of energy in the broader sense, which is now the accepted one all over the world—viz., that energy is one thing, though it may exist in a vast variety of forms, and that we preserve it, or we store it up, as long as we keep it in any form, provided it is so kept that we can ourselves use it afterwards.

Energy, though not stored, is not lost when it escapes us. It will continue to exist somewhere in the universe; but of course we do not consider it stored when it is not under our control, any more than we would consider grain stored if it were scattered on the river, although the grain might still be preserved somewhere.

The history of this invention of the storage battery is worthy of a few words, because it shows us how true all the way through is that remark made by Franklin, with which you are, of course, familiar, as illustrating

the utility of scientific things, even though they at first promise little. Franklin, as you know, was one of the earliest discoverers of electric phenomena, and someone noticing his experiments (all of which were of an apparently useless character excepting that relating to the lightning rod), said to him, "What is the use of it?" And Franklin's reply was, as you remember, "What is the use of a baby?" In other words, the baby was of no use until it grew; but when it did grow it was time to look for usefulness.

It is a little interesting to see how eminently the science of electricity—in its inception a mere matter of amusement, a toy—has realized this idea. How wonderfully it has developed since it began to grow! When it was almost a baby—and most of us can remember that time, for the telegraph is perhaps hardly beyond the early recollection of most of us—it was only amusing and useless; but within the last few years it has developed marvelously, and now we have the telephone, electric lights, electric motors, and all sorts of things of the kind.

The subject of storing electricity began to be developed very far back, or in the first year of this century. In the year 1801 a French investigator, M. Gautherot, noticed that if terminals or electrodes of a galvanic battery were immersed in water, and were of platinum or silver, after the battery had been removed these terminals possessed the property of giving off from themselves a feeble current of short duration—if connection was made to an appropriate instrument for indicating feeble currents. (The lecturer here exhibited an apparatus for the decomposition of water, and illustrated Gautherot's discovery.)

This observation was repeated by Ritter, of Jena, in 1803; but he carried it a little further. He found that by piling a series of coins one on another, separated by bits of paper wetted with salt water, and connecting them with the poles of a battery, he could pass a current through the pile of coins; then on disconnecting the battery, and connecting the ends of the pile of coins with an instrument that would show an electric current (the instrument used in that case being the hind legs of a frog), there would ensue a convulsive movement of the frog's legs, which showed the existence of an electric current whose direction proved to be opposite to that of the charging battery. He then noticed that a guinea, which was a gold coin not chemically acted upon, could be charged so that—having taken a guinea piece and placed a piece of wet paper on each side of it, and passed a current through it, and then removed it from the battery—he could get an excitement of the frog's legs by connecting them with the two surfaces of the coin. It was, as compared with all the usual electrical experiments, a very surprising one at that time. Here was the beginning of the principle of the storage battery.

This same experiment was followed by others. Sir Humphrey Davy, De la Rive, and Faraday at last got hold of the true theory of this action, although they did not make any application in the direction of a battery. Finally, Grove, who distinguished himself both as a lawyer and as a physicist, in 1839 developed what is known as a gas battery, which is unquestionably the founder of the distinguished family of the storage battery. The gas battery of Grove can be exactly illustrated by this little apparatus which I have here (illustrating). He made something substantially like this, with mere trifling mechanical differences. There were two glass tubes properly supported in a vessel of acidulated water, and inside each of them rested a wire or a strip of the metal, platinum. He passed a current of electricity through these (indicating). Entering one tube, it passed down through the water and through and out by the wire in the other tube. As I have said, oxygen gas collected in one tube and hydrogen in the other. He allowed the current to pass through until both the tubes were nearly filled with the gas. He then stopped, and connected these two wires with a galvanometer, when he not only found that he had obtained a temporary electrical disturbance, but had secured a continuous one; that it went on day after day. However, as the electric current went on flowing he noticed that the oxygen disappeared from one tube and the hydrogen from the other—in other words, that the oxygen and hydrogen were combining, and producing an electric current (when they were left to do that), having previously been torn asunder by the forcible passage of an electric current in an opposite direction through the apparatus. Here was realized the fundamental idea of the storage battery. There was a way of storing electricity, in the sense of converting it into a chemical change; or, in other words, developing potential chemical energy in the apparatus, so that electric energy could be reproduced in the same apparatus.

Things rested here for a good while (indeed until about 1855) when a distinguished Frenchman, M. Gaston Planté, made another great step in advance. He recognized the fact that peroxide of lead was a peculiarly fit substance for use as one of the plates in an electric battery; that if he used this peroxide of lead as one plate he got fully two units of electromotive force, as we call it, whereas, with most other materials, the maximum effect that could be obtained was either one, or somewhat in excess of one. He, therefore, made a battery, using lead as the base, and discovered another thing. He found if a galvanic current were passed between two plates of lead im-

mersed in sulphuric acid solution, that one plate, after a time and after reversing the action several times, came to be covered with peroxide of lead, more or less thickly, on the surface, while the other plate came to be covered with a spongy layer of metallic lead. In other words, lead accumulated in a spongy, porous state on the surface of one plate, and the peroxide of lead accumulated thickly on the surface of the other plate. Now, on stopping the galvanic or charging current—in other words, the current that was producing this change—and allowing the plates to act as an ordinary battery to produce an electric current, he found that the peroxide of lead was reduced to a lower oxide—that is, it had parted with some of its oxygen—and that the metallic lead acquired some oxygen, taking it from the water in its neighborhood, and therefore giving off hydrogen, and that the hydrogen given up from one side, and the oxygen given up by the other side, combined to form water again. This action of combination was a source of energy which was developed as galvanic energy; in other words, produced an electric or galvanic current.

He also observed that the materials of this battery did not travel about; that the peroxide of lead became reduced to something of the nature of protoxide, and that the metallic lead became a protoxide, but yet both stayed just where they were at the start. This was another advantage in constructing an apparatus for the storage of electricity. If during the operation of the system the peroxide of lead had traveled about, and thus visited some other part of the battery, you can easily see that the apparatus, as a whole, would have gone to pieces; but staying as it did where you originally put it, it was manifest that you could again pass a current through it, peroxidizing the plate on one side, and reducing the plate on the other. That then you could use the effect thus developed, the chemical energy thus rendered available once more, the peroxide being again reduced to protoxide, and the lead being oxidized to protoxide. And by passing a current through once more you would again peroxidize one side and reduce the other, and be just where you were before, ready to start a fresh current.

Now, assuming those things just as I have described them, this seems to be the perfection of a battery for the storage of electricity—something which had a great power for a given amount of material, and everything remaining just where it was. But in reference to Planté's form of a battery, these statements needed to be qualified. In other words it was found that the oxides, etc., would not remain absolutely unmoved, that the peroxide would scale off—flakes of it would fall; also that the action, which was intentionally stimulated at first, of oxidizing the one lead plate and reducing the other to a spongy state—that this action, which was very desirable until you got the battery made, was undesirable afterwards, but nevertheless would continue to go on, or until the plate, which was intended to be a lead plate with a surface of protoxide, by-and-by got to be protoxide all the way through and fell to pieces. There were various little side actions, which I will not weary you by attempting to describe, and which are merely technical matters, that interfered very seriously. In short, then, though it took a long time to get the battery into good working shape, it was no sooner in first rate condition than it began to deteriorate.

This battery, in that shape, however, was known for a great many years. I remember when it was first talked about and experiments were made with it. One gentleman whom I knew quite well, Dr. Percival, of Philadelphia, worked at it a good deal. Years and years ago he took out several patents in relation to the matter. It was, however, about the year 1880 that the first radical step in advance of Planté was made by M. Faure, a French inventor, who suggested that, instead of the long and tedious process which had been gone through with by Planté, to prepare his lead plates. They should be painted with a paste made of red oxide of lead, covering them with felt to keep the paste in place, and then in that condition should be put in the acidulated water, just as Planté did. Then a current being passed through the oxide (which was a powder) would be reduced to metallic lead on one plate, and oxidized to protoxide on the other. He found that that proceeding gave metallic surfaces covered with thick layers of metallic lead, or peroxide, as desired, and thus the storage capacity of the battery—or in other words, the amount of work which could be done by the current stored in it—was greatly increased. You can, of course, see that the more of these substances you have to react the more action you can get out of the battery, and the more current you can pass through in charging it. This made a marked improvement, and at first was hailed all over the world as a prodigious thing; but investigation and experiment proved there was still a very great lack in this apparatus. The trouble was that the oxide of lead, in this case also, after a certain amount of use, scaled off from the metallic plate behind, and so the battery became practically useless. As soon as this was noticed various inventors went to work, and probably the most successful of these in his solution of the difficulty was Swan, of England, who suggested the idea of taking a metal plate, punching it full of holes, causing or making the holes to flange outwards on both sides like the apertures for double dovetails, and then filling the holes with the oxides that were to be used. By this means he obtained something in which each little particle of the ac-

tive agent, the oxide powder or base that was put in, was held in the framing of the plate, being in effect riveted on both sides.

(At this point the lecturer illustrated with a model.) You see that each piece of material, being pressed in, had a head on each side so that it was not liable to drop out. In the second place, you had the metallic connections running around all through this active substance, and you had a great deal of porous active substance. Here, for instance, is one of the plates that have been used (illustrating). When this gets plastered full of the oxide of lead the oxide so gotten into it will hold well; and besides, there seems to be, from the relative positions of the bars in the plates which are opposite each other, much less tendency for the formation of sulphate of lead between the active surfaces and the metallic frame or plate than there was in the flat plates of Faure.

This was a very great step in advance. It still left, however, the difficulty that the lead grating was a little acted upon, so that after considerable use a tendency to break up or disintegrate was apparent. These filled-in plates with the battery charged would last for a year or more, but after that time there was a tendency to break away. Now, quite recently it would appear that improvements had been made, and though I cannot say, from my own personal knowledge, yet it seems on pretty good authority that by alloying certain other metals, such as antimony and mercury, with the lead, a material can be made which is relatively unattackable, so that the acid does not have any effect whatever upon the plate or grating, and thus we may secure a very long life for these plates. The plates, when prepared, are very different from each other; that is to say, the plate which is reduced to a spongy metallic lead has a light grey color. The outside one here is of that nature (indicating). Between those there is another set of plates, and the latter when looked at are of a dark slate color. These are the ones charged with protoxide (indicating), and are now manufactured at Newark, N. J., by the "Electrical Accumulator Company," who represent in this country a similar concern in England, the only difference being that the one in England is known as the "Electric Power Storage Company." They are manufacturing these now in great quantities, and they have already been put in use in a few places. Such a size as the one I have here has a capacity of 300 ampère hours—that is to say, it will give a current of one ampère, one unit, for 300 hours. In other words, it would transmit the current required by one incandescent lamp for 300 hours. It is also called a horse-power cell, meaning that the amount of energy contained by it is equal to one horse power for an hour. If there was any way of taking this charge out and converting it all into power it would be equivalent to a horse power for an hour; not that even theoretically it could do the work of a horse, because a horse in his ordinary day's work frequently works at a rate of much more than a horse power. A "horse's power," so called, is really the average work of a horse working steadily for ten hours a day without any special exertion.

[At this point a digression in the shape of a dialogue-discussion ensued.]

Mr. Vanderpool—What is the weight of that cell?

Prest. Morton—I think the weight of this is about 80 pounds. This particular cell is a new manufacture, and has only very recently come here.

Mr. Vanderpool—How many of those would be required in order to light your house?

Prest. Morton—That would depend upon the number of lights. If I wanted to run about 30 lamps, each of 16-candle power, I should require 20, or perhaps 25 of these; and they should be charged every day.

Mr. Greenough—Then it would take about a ton weight of those cells?

Prest. Morton—Yes; a little over a ton. I can tell you a little about that—that is, about the use which has so far been made of these things—giving you, so far as I can, what I know myself personally. Of course, there is much said about such things that is not very reliable. Now, in regard to my personal knowledge in this connection: On January 26, 1883, I used for the first time an installation of 25 batteries, substantially identical with this one, in my house. I had 25 of them put in, and connected with a dozen burners, which I hope to show you later on this evening. Those are used in this way: I had the battery charged, on the average, once every two weeks, and then it gave all the light I needed in two rooms (dining room and parlor) for two weeks, burning 12 lights. This would mean that occasionally all the lamps would be burning for the entire evening, when I had a dinner party, or something of that kind; but at other times I would only have one or two lights burning—just as we used gas. Of course, using only 12 lights with a battery of that size, I could use them for a long time without recharging; from one charge of the battery I could, in fact, run 10 lamps for 30 hours, or 30 lamps for 10 hours, or one lamp for 300 hours. These batteries ran very nicely for about six months, at the end of which time we began to have trouble, which trouble we did not understand at first, but found the cause of afterward. When these batteries were first sent out it was the opinion of everybody that for their proper management one must be very careful not to overcharge them; to stop the current the moment the lead was fully reduced on one side and fully oxidized on the other. At the end of about six months

we began to have trouble from some of the plates getting bent around so that they would completely mash out the thick bands of india rubber (placed between) and come in contact. Quite a number of them had to be taken out and replaced on this account. After a time, however, it was discovered that the method we had followed was all a mistake; that we must do just the other thing. We might overcharge the batteries as much as we pleased without ill effect; but we must not let them run down, for that formed a coating of sulphate of lead, and thereby created a tendency to bend and break up. By the time this was found out we had injured the battery to some extent, but we replaced a number of the plates, and then it ran with entire satisfaction for two years more, or until last summer, at which time I wanted it for use here in the Institute and moved it over from my house. When the battery was moved we wanted to arrange the cells in a different way, and that led to the taking out of the plates. I found that a good many of them seemed to be as good as when they were put in. My impression from this experience is that these plates, as they were then made, are perfectly safe for two years. With proper care in running, and being careful to always charge them fully and to never let them run down too low, I believe they are perfectly safe for that length of time. That is the history of one installation. About six months or so after those were put in my house another set was put in a building at No. 80 Broadway, New York city, where they had a dynamo machine and also a battery. The dynamo ran during business hours; but at 6 o'clock, when the engineer and the fireman went away, the dynamo was stopped and the battery ran the lights all night—many lights from 6 to 9 p.m., and a few lights during the night—until the next morning when the dynamo was started again. The result has been very satisfactory. The owners of the building told me that they were satisfied with the running of the apparatus. The battery was, however, placed in a bad position. It was down quite near the engine and boilers, and the cells were liable to get very hot, and that made a little irregularity; but a few months ago they were replaced by new batteries made in this country—those that were used at first were imported from England—and since then the batteries have been running with entire success.

There is also an outfit which has lately been placed in the building No. 44 Broadway, New York, where the company that manufactures this battery has its office. They are just beginning to run them there, and I would advise any of you to step in and see them, either there or at No. 80 Broadway, if you are in that vicinity. Those are the only plants running in this vicinity that I know of at the present time. The reason they have not started more is that, though the company came to this country in 1883, there have been all sorts of legal complications affecting the ownership of the Faure, Swan, and other patents under which they operate. It has taken about three years for the company to straighten out matters by a series of civil suits, so that they might know whether they or somebody else owned the patents on which they proposed to work.

I have made no mention so far, in speaking about the history of the battery, of Mr. Brush's developments in that connection; but I do not know whether they particularly interest us now, because it is a mere question of patents. The form of battery made by Mr. Brush has not been a success. He put in several plants in New York in 1883. They were kept up for a few months, when they broke down entirely and had to be taken out. At Cheyenne, Wyoming Ter., they have, by force of persistent efforts, kept a plant going under the charge of one of our graduates; but the prospect even there is not encouraging. The only approach to success is on the Pennsylvania Railroad, where they have for a little over a year been lighting a number of cars which are run between New York and Philadelphia; and there it has been very expensive in the way of replacement of plates. Dr. Dudley, who has charge of affairs of that sort for the Pennsylvania Railroad, told me they were satisfied to continue their use because it was a nice thing to have in the cars, and they proposed to keep it up. They are trying to improve and cheapen this form of battery, and I imagine their efforts will meet with greater or less success in the near future. In 1884, I met Mr. Preece, the Superintendent of English Telegraphs, who told me he had for eighteen months been using in his house a set of cells of this general character with great satisfaction. He ran it in this wise: His gardener every day attended to starting up the engine—I believe it was a gas engine—which ran a small dynamo that charged the battery. When he had run it for so many hours he turned it out, and the rest of the apparatus took care of itself automatically. That is to say, when he shut off the engine the dynamo was cut off by an automatic switch from the battery. I have noticed in English electrical publications some letters showing that several private houses in England are lighted in that same way; and I have also seen a good many certificates, published by this English company, showing that Mr. So-and-so put in a battery in 1883, and says that it is still working successfully, and he is much pleased with it.

So, then, apparently something is being done. Dr. Dudley, who has just returned from a long tour in Europe, tells me that he saw a number of plants in England of that nature. It has worked better on a small scale

where it did not come in competition with general electrical lighting or with gas lighting. Naturally, a new thing of this sort is expensive. It is not cheap by any means, nor do I anticipate that it is likely to become so; but in the way of luxury it is a nice thing. Of course, the absolute steadiness of the light, and its freedom from heat and from any vitiating effect upon the air, commend it to those who want the nicest and prettiest light that can be got regardless of expense.

Mr. Greenough—What proportion of electrical energy can you get out of that battery?

President Morton—I made a number of experiments in 1883, and found that we got out about 82 per cent. of the electrical energy put in—that is, measuring the quantity of current and the electromotive force in charging, and then taking the quantity and the electromotive force it had when it came out, I found that the latter was about 82 per cent. of the former. If it stood for about 16 days it lost about 7 per cent. more.

Mr. Greenough—How would it be after you ran it for a year or so?

President Morton—I was not able to make a test of that nature which I could regard as satisfactory and fair. I did make a test after the battery had run about a year; but the battery had then been somewhat maltreated, as I have before described, and, therefore, I do not think the test was fair to the battery. We found that the efficiency was then not much more than 50 per cent.—that is, we got out only 50 per cent. of what we put in.

Mr. Greenough—Can the lamps be connected with the battery and dynamo at the same time; or can you charge the battery and run the lamps both together?

President Morton—Certainly; and with the best effect. By such an arrangement the battery becomes a perfect regulator of the current for the lamps. This I once showed here in a striking manner as follows: Some time in 1883 the Electrical Society of New York asked me if I would lecture to them upon something. Agreeing to the invitation I addressed them on the subject of the storage battery, and on that occasion I illustrated this point, here, in this wise: I had a number of electric lights, and I had a switch so arranged in connection with the dynamo machine that I could fluctuate the current that was developed by the dynamo in an extreme degree—bring it up to full brightness, and then reduce it to comparative darkness, by moving the switch backwards and forwards. I then connected the storage battery as a shunt, so that the current from the dynamo flowed into the storage battery and to the lamp by two parallel paths, and then back again into the machine from the other pole of the battery and from the lamps, so that if the current from the machine was cut down then the battery would take care of the lamp; or if the machine was giving current in excess it would overflow into the battery. Now, the moment the battery was thrown in as a shunt in that way you could not tell when the switch, which had before produced the violent fluctuations, was turned one way or the other, the lamps being absolutely steady. Of course, that depends upon proper arrangement. I cannot do that now with the battery here and the lights over at my house, the connection being only an ordinary telegraph wire.

Mr. Vanderpool—Do the lights keep up the same intensity after running awhile?

Prest. Morton—They do in a remarkable manner; until you get to a certain point, when the battery is nearly exhausted, there is substantially no change in the current. You start the current on from the battery, and from the first instant, if the battery has just been charged, for a minute or so it will drop off a little. After that the current would be represented by almost a perfectly level line for a great number of hours. For instance, if it would run for thirty hours, for the first fifteen minutes there would be a little drop. After that it would be sensibly steady, the drop not being more than one or two per cent. of the entire force in the course of 25 hours. Then there would be a slow drop until within about an hour of the time when the battery was nearly exhausted, and then the current would come down very fast—you could almost see the lights fall; this is a point to which you should never let the battery get, if you want to take care of it. By having a small hydrometer floated in the acid liquid of the battery, and observing it from time to time, you can tell whether your battery is well charged or not.

Mr. Greenough—Does it take long to charge those batteries?

Prest. Morton—Yes; because we cannot charge them even as fast as we can discharge them. For example, it will not do to discharge one of these ordinary batteries at a faster rate than 30 amperes, and at that rate we can discharge them in 10 hours. One of these batteries should contain about 300 ampere hours; but in charging them you must not use a current higher than 20 amperes, consequently you must spend 15 hours in charging them at this rate.

Mr. Vanderpool—What determines the rate of discharge of the battery? How is that regulated? Suppose it was 30 amperes, and you put on more light?

Prest. Morton—You must not put on more lights. The battery can be discharged in a minute—not that you will very perfectly discharge it then. It is found if you make a close circuit you will get a tremendous discharge,

and the charge will be apparently gone; but if you let the battery stand awhile you can get another discharge out of it. The explanation of this is, in the sudden action, it is only the particles on the surface that act. Such treatment, however, injures the battery.

Mr. Greenough—If you use a small number of amperes could you use an arc current?

Prest. Morton—Oh, yes; there is no objection to using an arc current. In fact, you have to use a pretty intense current, because it is usual to charge these batteries in series. Then the resistance is sufficient to make it desirable to use an arc current. Of course, the question of the electromotive force of the current and its quantity is one that is controlled by the battery. If you use too great an electromotive force you will put too much through your battery; so that the capacity of the battery limits the electromotive force you can use upon it. For example, suppose you had a current directly from the Brush machine with nothing else in the circuit. Now, you put one of these batteries in such a circuit and it will burn the plates. To save the battery, in order that it may not be injured by the current, you must have it arranged to receive only a limited current; for example, it may take the place of an arc light. One of these batteries may take the place of one or two arc lights in a series, and then it will only take its share out of the whole electromotive force of the circuit. That has been frequently done.

Mr. Vanderpool—Suppose you had half a dozen different houses with batteries in, and attempted to charge them on an arc wire?

Prest. Morton—Then you would charge them in series, and each battery would take the place of one or two arc lamps.

Mr. Vanderpool—Suppose one battery was exhausted and the other was full?

Prest. Morton—They would take the same amount of current. In the one that was full the hydrogen and oxygen would escape. When a battery is run down and you begin to charge it there is hardly any escape of gas. When fully charged, then all the gases developed by a charging current escape. To continue charging would be throwing away your current, because you would be causing it to decompose water into the gases which escaped. You would be storing, in the sense of turning electric into chemical energy; but you would be throwing this chemical energy off into the atmosphere.

There is one other point connected with the general subject I will mention which will interest you, and that is with regard to the durability of electric lamps. You know a great many tests have been made, and it has been shown that good electric lamps will last 1,000 hours, on an average; but it is not so well known generally that that does not mean 1,000 hours of 16-candle power. On the contrary, after a lamp has been in use for a certain number of hours—and sometimes for only one or two hours—with exactly the same current, it will not give anything like the same candle power. The tests made at Philadelphia in 1884 showed that even for the Edison lamp, which gave the best results of all the varieties tested, 1,000 hours was a very much longer time than a lamp would burn at its full original 16-candle power. It showed that most of them, after burning 1,000 hours, would give only half their original candle power with the full current, and at 500 hours the average was about 60 per cent. of their original candle power. I have frequently noticed, in offices and stores, electric lights burning which were not more than 8 or 10-candle power, and I have not the least doubt but that they were 16-candle power when put in. When such a lamp has fallen to 10 or 12-candle power it is still taking just the same amount of electric current to run it as at first. The change is due to a molecular change in the carbon filament, by reason of which the current is unable to produce a corresponding amount of light.

Mr. Greenough—Do you think that the battery manufactured in Newark will be a success?

Prest. Morton—I really think it is. It will be an expensive thing for a long time, if not always; but aside from that it is, I believe, a success, and will have a large use.

Mr. Greenough—You say that if you turn a current of Brush light on a battery it would burn it up?

Prest. Morton—Yes, if there were no other lamps in the circuit, and if the current was not controlled.

Mr. Greenough—I thought that in the Brush series each lamp required an electromotive force of about 50 volts; and if they had on 40 lamps, then there would be 2,000 volts.

Prest. Morton—If a machine is automatically adjusted it will not give any excessive current, even if only a few lamps are in circuit. In other words, the ordinary Brush machines are arranged to give a current of about 10 amperes. If anything happens so that any more current than that would tend to be produced, an automatic arrangement checks it. Therefore, under those circumstances, you could not hurt the battery, because you could not get an excessive current. When I spoke of a current burning a battery I was supposing that you had a full Brush current on the battery with no automatic check.

Mr. Greenough—You said you could put that in a circuit just as you would a lamp?

Prest. Morton—Yes. You see, a battery arranged as we would use it would correspond to an electromotive force for each cell of 2 volts; 25 cells would therefore equal 50 volts. Therefore that would be just equivalent to one lamp. If, however, we desired to use the Edison lamps requiring 100 volts, we would need a battery of 50 cells, which would replace two Brush lamps. These 100-volt lamps would require only half as much current in amperes to run them as the 50-volt lamps, to produce equal light; so that with 50 cells and these lamps you could have 60 lamps in place of 30.

Mr. Greenough—The current of all the other arc lamps on that circuit would then go through it?

Prest. Morton—Yes; just as the same current goes through all the lamps on an arc circuit.

Mr. Greenough—Will that hurt it any?

Prest. Morton—No; because the quantity of the current is the same at each point. It is as though you had a pipe with a pump forcing water into it; at one point it had to force water up ten feet, at another place ten feet, and ten feet at still another place. Now, take any one of those places and the force that is exerted in raising the water in that place is only ten feet, but the pump may be exerting a force of 100 feet if there are ten of these places, and the amount of water flowing is identical at each point.

Mr. Vanderpool—Suppose that you should cut out three of them?

Prest. Morton—Then the water would flow faster, and more would go through. Suppose each of these pipes was of just such a strength as to stand the first flow, if some of these rising parts or steps were taken away, so that the current would be more violent, it would break the pipes.

There are dozens of batteries which I have not mentioned, but the only important ones are: First, one of M. Julien, who has come to this country in the last few months with a battery and a car. The battery is substantially like the one before us, and its only claim is that it has a non-attackable metal. Second, another inventor in England, named Parker, claims to have a non-attackable metal. This feature of securing a non-attackable metal or alloy for the base of the plates is, of course, a very important one, for on it largely depends the cost of maintenance of the system.

I have detained you longer, gentlemen, than I intended to, and so I will stop here.

[At the conclusion of the lecture President Morton received the members of the Society at his residence, where a most entertaining social seance was held. In passing, it may be remarked that the Director of the Stevens Institute is as clever in the parlor as he is in the lecture room.]

[Prepared for the JOURNAL.]

New Works of the South Metropolitan Gas Company, at East Greenwich, London, England.

By NORTON H. HUMPHREYS.

By the courtesy of Mr. George Livesey, Chairman, and Mr. Frank Livesey, the Chief Engineer of the South Metropolitan Gas Company, the writer recently had an opportunity of walking round the new works now in progress at East Greenwich, and as the design of the same is unique in several respects, especially with regard to extent of productive power, a brief description may be interesting.

This Company, as its name implies, distributes gas to that part of London situated on the south of the Thames. Its district is of an irregular shape, extending, with one or two trifling exceptions, along the south bank of the river from one end of the city to the other—a distance of perhaps 14 or 15 miles; and the width (which varies considerably at different points) averages something less than half this distance. There is a crowded and busy population in the area within a distance of about two miles of the river, but further out the district is of a suburban character, comprising villa residences, etc., gradually thinning out until the open country is reached; and this neighborhood has undergone a rapid increase in the course of the last few years—new roads and rows of villas springing up in all directions. This, together with the wise policy and prudent management which the affairs of this undertaking have always received from the first, causes a rapid increase in the demand for gas, which of course necessitates an energetic extension in the way of productive power.

The wants of the consumers have hitherto been supplied from four or five stations situated on the banks of the river (so commanding water carriage for coal), and at the headquarters at Old Kent Road, which stand nearly in the center of the district; but the necessity for additional plant, demanding more space than that available at either of these stations, which are all closely surrounded by buildings, led to the purchase of a site close to the river at the eastern end of their district, comprising some 96 acres of land, and adjoining the tar works belonging to Mr. F. C. Hills, a gentleman well known in connection with gas purification. It is about five miles below London Bridge, and four from the Old Kent Road station, with which it has been connected by means of a 48-inch main. The ground is not much bet-

ter than a marsh, having probably at one time formed part of the bed of the river, and consequently it is necessary to go down some 20 feet or so for a fair foundation. A considerable portion of preshore has been reclaimed from the river by the erection of a wall, built of concrete blocks resting on sheet piling, along the whole length of frontage. A good approach walk, with footways, etc., leading up to the offices, is also in progress.

At about the center of the river frontage a jetty is constructed, built of iron, and supported by very massive cast iron pillars. In shape it resembles the letter T, and will take three coal vessels along the front and one in each bay. There are 24 cranes, worked by hydraulic power, having cradles or skips capable of holding one ton of coal each; and there are three lines of railway, ordinary gauge, on which run trucks capable of holding about five tons each. The deck of the jetty is about 35 feet above high water, and as the rise of the tide is 20 feet, the maximum extent of lift is some 60 feet. Each crane is capable of lifting 65 loads per hour, including the transference of the same to a truck, representing a total unloading capacity of 1,500 or 1,600 tons of coal per hour. The steam engines, boilers, and hydraulic machinery are contained in a covered under-deck, and a little glazed cabin is provided for the driver of each crane. From the jetty a viaduct extends in a straight line nearly the whole breadth of the land, and inclined ways are provided so that a low-level service for the transit of coke, purifying materials, etc., can be laid down. On the left are the retort houses, 12 in number, placed broadside to broadside, have a coal store between each two, also one at each end, and a covered branch runs off from the viaduct into each store, so that the coal is conveyed direct into the retort houses. Immediately on the right of the viaduct are rows of buildings for the boilers, exhausters, and pumps; and some distance behind are rows of washers and scrubbers. A vacant space is designedly left between the exhausters and washers, so that in the event of the experiments now being conducted on purification by liquids being successful the same could be adopted without alteration of connecting pipes. Then come the purifiers, comprising 12 sets of 8 vessels each, arranged in double rows with space between for lime or oxide sheds. These rows are laid parallel to the river, and extend nearly to the outskirts, plenty of room being left for the meters. Returning to the left hand, at the back of the retort houses is a large space available for a coke ground, and beyond this is the gasholder ground, having accommodation for five gasholders, each to contain 8½ million cubic feet of gas.

The whole of this scheme is not to be carried out at once, but the object is to be able to erect section by section as it is required. At present one limb of the jetty and a portion of the viaduct is actually constructed, and the river wall is in a forward state. One retort house is complete and ready for use, also the foul main and condenser. The boiler house and exhauster house (which will serve for four sections) is nearly completed, having the pumps, exhausters, etc., fixed, and one set, comprising three washers, two scrubbers, and six purifiers; so that if necessary gas could be manufactured at once. Sufficient progress has been made to give some idea of the appearance and working of the whole plan, which provides for 12 separate sections, each capable of producing 5 million cubic feet per day, or 60 million in all. It resembles the Beckton works so far as the dividing into separate sections is concerned, but is totally different in every other respect. The Beckton works are laid out with imposing effect, covering a vast area of ground, and having some regard to appearance both in a general and also in an architectural sense; but here, whilst everything is markedly strong and substantial, there is no direct attempt to gratify the eye. Consequently, whilst retaining ample working space where it is wanted, these works will only cover about one-half the area of the Beckton works, although their productive power will be fully 50 per cent. greater. There is a striking absence of the usual ornamentations, such as polished capitals and tie-plates, scrollwork in the spandrels, etc., with regard to the ironwork; and the whole of the brickwork is of plain yellow brick. I do not think there is even a plain string course or beading throughout the works, unless it also serves some useful purpose. But they are by no means ugly. The whole is nicely balanced and well proportioned, and conveys a pleasing effect of neatness and appropriateness, which is not lessened in the eyes of practical men by the consideration that the "cost of capital per 1,000 cubic feet of gas made" will certainly be low.

The retort house already completed, is 485 feet long, by 120 feet wide, including a coal store on each side. It contains a row of double retorts, comprising three blocks of 15 beds in each, having ten retorts in a bed, or a total of 450 through retorts. The settings are of considerable height, and the retorts are arranged in five tiers, one above the other. This narrow and high form of setting has been found, by experience at another works, to give very successful results. West's system of drawing and charging by machinery is used, and self-sealing lids on the retorts. The coal is taken in at the ground floor, passed through a breaker, and carried up into an overhead hopper, from which it is delivered to the charging machine as required. The breaking and elevating machinery is worked by a 9-horse power gas engine. The hydraulics are of wrought iron, in separate sections to each bed, and fitted

with Livesey and Tanner's arrangement for drawing off the tar, and keeping the pipes sealed in liquor, and which is the only device I have yet seen which really accomplishes this end. The whole of the tar deposited in the hydraulic is run off by separate pipes and conveyed to a tank at a slightly lower elevation, situated outside of the retort house at one end, and from this it can be distributed to barges or to the retort house fires by gravitation. There is a chimney at each end, and also between each section, not rising higher than the ridge of the roof, and each chimney is fitted with an arrangement on the top, devised by Mr. Tysoe, the resident Superintendent, by which it can be partially or wholly closed. This is to be used when the retorts are standing off on Sundays. The retort house is roomy and well ventilated, the coke hole in particular showing a great improvement in this respect. The gas, on being collected from the hydraulic, passes through a long length of 30-inch pipe, carried round the retort house and coal store. The condensers are novel in character, and consist of a massive convolution of 36-inch pipes, which serves as a support for a water condenser, in which the gas passes through a series of narrow V-shaped chambers, between which a current of water is made to flow. By this means the temperature of the gas can be nicely regulated. A pair of exhausters, driven by a direct acting horizontal engine, are provided for each retort house. Each exhauster house will contain six sets, four for regular work, and two to act as duplicates when necessary. The washers are of the Livesey type, the construction of which is well known. A series of tanks situated below the viaduct, afford ample storage for liquor. It was found necessary to excavate to a great depth to get a good foundation for this structure. By simply connecting the brick piers with party walls, excavating out the earth, forming a sound bottom, and rendering the whole with cement ample storage room was provided at a cheap cost. After the washers the gas passes through two scrubbers in succession, and here it is treated with a larger quantity of clean water than is the usual practice. Mr. Frank Livesey sometimes uses as much as 30 gallons per ton of coal carbonized, and finds that this plan greatly improves his working results. The purifiers consist of a row of eight vessels, each 30 by 67 feet, constructed on a basis of 400 square feet horizontal area for each million cubic feet of gas. They are not enclosed by buildings, but a traveling roof, large enough to cover one box, is provided, so that the men can work under cover in wet weather. The station meters are sunk in the ground, a rendered brick tank forming the case, and this is covered by an arched iron roof rising above the surface; so there is no expense for meter houses.

One of the gasholders is now in process of erection. It will be the largest gasholder in the world, having a cubical content of 8½ millions cubic feet of gas. The diameter is 250 feet, the height is 175 feet, and it comprises four lifts. The curbs and outer sheets are constructed of steel plate, and the roof, which is untrussed, rises 20 feet in the center. The curve of the dome is flat in the middle and more rounded at the outside. The guide frame comprises a large number of wrought iron columns and diagonal framing, and the whole is a development of the principles followed by Mr. George Livesey in the designing of his celebrated gasholder at old Kent road. The tank is 254 feet in diameter and 45 feet deep, the top edge standing 15 feet above ground level. It is built of concrete, and there is an inner wall 156 feet in diameter, springing from about half way up the side of the dumpling, also built of concrete. So the tank is really annular, a considerable space being left dry in the center, whilst the inner wall acts as a support to the timber framing which is necessary for the support of the roof. It will be observed that the storage capacity is small as compared with the producing power, and the reason of this is that the old Kent road station, which is centrally situated for distribution, is to be used more as a storage station.

The contractors for the ground and building works, including tank, are the well-known firm of Messrs. Docwra & Co., of London, and Messrs. Ashmore, Benson, Pease & Co., of Stockton-on-Tees, have the holder in hand. Messrs. Cutler, of Millwall, have erected the purifiers, and the exhausters and engines are made by Messrs. B. Donkin & Co., of Bermondsey. The design of the whole is the joint production of Messrs. George and Frank Livesey, and they are being carried out under the superintendence of the gentleman last named. These eminent gas engineers are to be congratulated upon the progress already made in this their latest achievement. Every visitor to this new works will be struck with the appropriateness of each part for its intended purpose, and with the evident fact that in each appliance a maximum of reliability and efficiency has been secured at a minimum cost.

Senator Worth's Bill to Create a Board of Gas Commissioners for the State of New York.

Senator Jacob Worth, who represents one of the Kings county districts in the present legislative assembly of this State, is the putative sponsor of a bill to place the gas companies of New York under the control of a State Board of Gas Commissioners. The following is a report of the text of the measure:

SECTION 1.—Within ten days after the passage of this act the Governor, by

and with the advice and consent of the Senate, shall appoint three citizens of this State, who shall constitute a Board of Gas Commissioners, who shall have control of all corporations engaged in the manufacture of and sale of gas used for the purpose of illumination, and he shall also designate the chairman thereof. Said Board shall appoint a secretary, who shall keep a full and faithful record of its proceedings, and shall serve such notices and perform such other duties as the Commissioners may require, and who shall, before entering upon the discharge of his duties, be sworn to faithfully perform the same.

SEC. 2.—One of said Commissioners shall be appointed for one year, one for two years, and one for three years, and annually thereafter the Governor in the same manner shall appoint as herein provided one Commissioner to serve for three years from the date of his appointment, and until his successor is appointed and has qualified. If a vacancy occurs by resignation or otherwise, the Governor shall in a like manner appoint a Commissioner for the residue of the term, as hereinbefore provided. Any two of said Commissioners shall constitute a quorum for the transaction of business, and may hold meetings at any time or place within the State.

SEC. 3.—Said Commissioners shall be sworn to the faithful performance of the duties of their respective offices before entering upon the discharge of the same; any person in the employment of, or who owns any stock in a gas corporation, as aforesaid, or who is in any way directly or indirectly interested pecuniarily in the manufacture or sale of any material used by such corporations, shall not be eligible for appointment to nor to hold the office of Commissioner.

SEC. 4.—The annual salary of such Commissioner shall be five thousand dollars, to be paid quarterly from the treasury of the State. The annual salary of the secretary shall be twenty-five hundred dollars, payable quarterly from the treasury of the State. Said Board shall also have power to employ such additional clerical force, not exceeding in number three persons, however, at salaries not to exceed in the aggregate the sum of three thousand dollars per annum, as it may find necessary for the purpose of preparing the reports required by this act, and such other clerical duties as may be required of them by said Board. Said Board shall also have power to employ experts temporarily whose services it may deem to be important in any investigation herein provided. In the discharge of the duties of their office transportation shall be furnished them, and they shall have procured for them, by the State, the necessary books, stationery, and statistics incidentally necessary for the discharge of the duties of their office, and they shall have reimbursed to them quarterly the expenses and disbursements they may have necessarily incurred in traveling, and the necessary travel expenses and disbursements of their clerks and experts, and a statement of such expenditure in detail shall accompany the annual report. The salaries and expenses authorized by this act shall be audited and allowed by the Controller, and paid in the first place by the State Treasurer upon the order of Controller out of any appropriated funds from time to time remaining in the treasury. The sum of thirty thousand dollars, or so much thereof as may be necessary, is hereby appropriated to carry out the provisions of this act. The Commissioners shall be provided with an office in the Capitol, at the city of Albany, in which their records shall be kept.

SEC. 5.—The annual total expense of said Board of Gas Commissioners, including salaries for commissioners, clerks and experts and additional clerical force, printing of reports, and all other expenses incident to said Board excepting only rent of offices, shall not exceed the sum of \$30,000.

SEC. 6.—The annual expenses of the Commissioners and secretary, including salaries, shall be borne by the several corporations affected by this act in proportion to their paid up capital, and shall be assessed and recovered in the manner provided for the assessment and recovery of the expenses of the Railroad Commissioners.

SEC. 7.—Every such company shall annually make a return to said Board in a form and at a time prescribed by said Board, setting forth the amount of its authorized capital, its indebtedness and financial condition on the first day of January preceding, and a statement of its income and expense during the preceding year, together with the account of its dividends, paid or declared, which shall not exceed the rate of 10 per cent. in any one year. Every such company shall also at all times, on request, furnish any information required by the Board concerning the condition, management and operation of the company, and shall comply with all lawful orders of said Board.

SEC. 8.—All net earnings derived from the business of any such company, over and above the cost of conducting the same and the payment of dividends above provided for, shall be applied to the reduction of the price of gas sold to consumers for the succeeding year.

SEC. 9.—Said Board shall have the general supervision of all corporations engaged in furnishing illuminating gas, and shall make all necessary examinations and inquiries and keep themselves informed as to the compliance of the several corporations with the provisions of the law.

SEC. 10.—Upon the complaint, in writing, of any consumer of gas furn-

ished by such company, of the quality and material sold and delivered by such company, the Board shall notify such company of such complaint by leaving at their office a copy thereof, and shall thereupon, after notice, give a hearing to such petitioner and such company, and after said hearing they shall make such orders and take such action as may be necessary thereto, and a report of the proceedings and the result thereof shall be included in their annual report to the Legislature.

SEC. 11.—The Commissioners shall, from time to time, examine and test the gas furnished by the companies for illumination, and if after said examination any change as to quality of said gas is in their opinion necessary they shall notify the proper company, and shall thereafter give said company a hearing and proceed as in the last foregoing section specified.

SEC. 12.—The Board, whenever any such company violates or neglects in any respect to comply with the provisions of any law, or refuses or neglects to comply with any lawful order of the Board, shall give notice thereof in writing to such corporation. Any person or corporation thereafter refusing to obey the legal order of the said Commissioners shall be liable to a penalty of \$100 for each refusal. The Board may also present the facts to the Attorney-General, who shall take such proceedings thereon as may be necessary for the protection of the public interests.

SEC. 13.—The Board shall make an annual report of its doings to the Legislature in January, with such suggestions as to the condition of affairs or conduct of the companies as may be deemed appropriate.

SEC. 14.—No such company shall hereafter issue any bonds at less than par value, nor increase its capital except for construction, unless approved by said Commissioners, etc. The proceeds of all funds or stocks hereafter issued shall be applied to the payment of obligations incurred for the enlargement and extension of the works, and the purchase of real estate for the use of the company, or for the payment of liabilities existing at the time of the passage of this act.

SEC. 15.—All acts or parts of acts inconsistent herewith are hereby repealed.

SEC. 16.—This act shall take effect immediately.

Rules and Regulations Relating to the Use of Gas Machines.

In response to several inquiries we herewith republish the rules and regulations, adopted by the New York Board of Underwriters, to be observed by insurance companies of this State in their dealings with those who employ gas machines. Mr. D. A. Heald, of the Home Insurance Company, assisted by Messrs. Coit, Ogden, Adee, Nestell, and Oakley, drew up the rules, and the following is a copy of their report:

Your committee, having carefully examined the subject submitted to them, beg to present for your adoption the following rules and regulations in regard to subject under consideration, and to suggest that this Board decline to give its approval to any gasoline gas machine by name; but if upon submission to said Board, or its experts, such machine is found to conform strictly to requirements hereinafter mentioned, a certificate to that effect will be issued by said Board upon the manufacturer signing an agreement stipulating that each machine erected or placed by him or through his agency shall, in every way, conform to the rules and regulations of this Board as to construction, location, and arrangement.

1st. That the vault or gas house shall be placed at least 30 feet from any insurable property.

2d. The machine and all the apparatus shall be made of good material (copper being recommended as the best and safest), and in a substantial and workmanlike manner.

3d. That the generator or any apparatus containing gasoline or other inflammable fluid, or any gasholder, shall be placed in a vault outside the building or premises to be insured, and not less than 30 feet distant from any insured property.

4th. Stopcocks must be placed on both the gas and air pipes near the generator in the vault, and also on the gas pipe where it enters the building and on the air pipe near the air pump, when the pump is in the cellar or building.

5th. The vent and filling pipes shall be so arranged that one cannot be opened without opening both.

6th. In case the air pump of a machine is placed in the cellar of the building an automatic check-valve shall be inserted in the air pipe to prevent the backward flow and escape of gas or gasoline through the pump into the building; and the pump shall be so constructed and set that the air supplying it is drawn through a pipe leading from without the building, and rising at least one foot above the ground; provided, that where machines of not over 50 lights capacity are used without the aid of artificial heat of any kind, and are provided with an automatic check-valve, as above called for, the air inlet-pipe from outside of the building to the pump or blower may be dispensed with.

7th. In all cases where the air pump or blower of any machine is located within a building such pump shall be provided with an outgoing pipe for carrying air to the generator, and a returning pipe for conveying gas from such generator to the premises to be lighted.

8th. Whenever hereafter it is necessary to apply artificial heat to the "generator" or tank containing gasoline or other inflammable material, such heat shall not be applied directly to the generator or its contents by steam pipes, or any method other than by heating the air as it passes from the pump or blower to the generator by the introduction of a steam pipe within the air pipe, such steam pipe to be carried through the air pipe to a steam trap inside of the vault surrounding the generator, or to a point distant at least 5 feet from the generator, and from thence be brought to the surface of the ground.

In case an apparatus already in use, arranged to utilize artificial heat in any manner other than as above provided, cannot conveniently be made to conform to the above requirements, the generator of such apparatus must then be provided with a safety valve weighted to open at a pressure of not over one-half pound to the square inch; or in lieu of this the whole apparatus, including the pump or blower, must be placed outside of the building, and not within 50 feet of any insurable property.

9th. Where machines or apparatus are used in which the gasoline or other inflammable material is vaporized by artificial heat after leaving the reser-

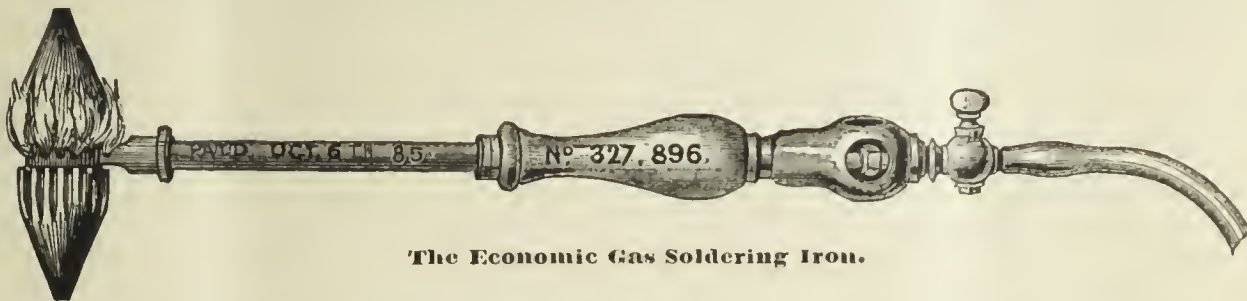

The Economic Gas Soldering Iron.

voir or tank, the whole apparatus must be placed at least 50 feet from any insurable property, and be connected with the building to be lighted by gas pipes only.

No "mixer," "equalizer," or other apparatus, attachment, or appliance in which gas is held for dilution or enrichment shall be located within the building to be lighted.

10th. Retorting gas machines or apparatus, in which gas is produced by fire-heat, must be located outside of the building to be lighted, and not within 50 feet of any insurable property.

11th. All the main gas pipes leading to the premises lighted must have an inclination toward the gas machine, so as to return all condensation that may take place in the pipes.

12th. The premises to be lighted must be securely piped, the pipes thoroughly tested by competent persons before the gas is let on, and the pipes to be so put up as to avoid, as much as possible, an accumulation of any condensation that may occur inside the building lighted.

13th. Particular inquiries are to be made as to the competency of the persons who are to have charge of filling the machine, and to ascertain if they are informed as to the importance of having the vent open and the air pump shut off whilst the machine is being filled with fluid; and of the great danger of using a light in or near the gas house or vault.

14th. No barrels containing gasoline or other like fluid, or from which gasoline has recently been emptied, shall be allowed to be kept in any cellar, barn, shed, or outbuilding where other property is kept, or where there is a liability to use a fire or light.

These rules and regulations are based upon the experience gained from many years of careful study and investigation, and are promulgated by this Board as constituting a perfect apparatus, without reference to any particular system or class of machines now in the market. A strict compliance with these requirements being essential to the production of an absolutely safe gasoline gas machine, this Board will not hereafter pass its approval on any apparatus which does not conform to the standard herein laid down; and as most of the machines now in use can be changed to meet these requirements at small expense and without dispensing with the apparatus already in place, it is earnestly recommended that all users of gasoline gas machines at once secure such changes as may be necessary to bring such apparatus up to this standard of safety.

Inspectors must be careful to observe that the requirements above noted are fully and literally complied with in all cases, before approving or giving consent to the use of any gasoline gas apparatus, as any machine not conforming strictly to the above rules and regulations will stand condemned and its use be prohibited by this Board. All former rules and regulations in regard to gasoline gas machines, which have been promulgated by this Board, are merged in and shall conform to these rules.

The Economic Gas Soldering Iron.

The Colwell Lead Company, of No. 63 Center street, this city, acting as agent for the "A. Giles Manufacturing Company," offers to the trade the "Economic Soldering Iron," a fair understanding of the general features of which will be obtained from an inspection of the illustration herewith presented. The chief advantages claimed for this tool are convenience with economy and evenness of temperature. A gas pipe, provided with an ordinary cock for turning on or shutting off the gas supply, runs through the wooden handle. The wooden handle and the bits are connected by a large gas pipe, open at the end, for admitting air to mingle with the gas that issues from the smaller pipe, and in consequence it will be seen that the gas is burned under somewhat similar conditions to those maintained in the Bunsen burner. Between the two fluted bits, as shown in the cut, is placed a ring of brass, having a number of perforations in its circumference, through which the gas passes out to be consumed. When the iron is in duty a rubber tube connects it to a gas jet, and the gas feed is regulated or controlled by the cock next to the handle. As revealed by the cut the flame envelops the upper bit, and when the latter is brought to the proper temperature it is ready for the soldering process, while, by the act of reversal, what was previously the under bit becomes the upper section, and the latter is being brought to the necessary temperature during the time that the first is cooling

off in the work to which it is devoted. In effect, therefore, a simple reversion of the instrument at the proper moment shows that the iron may be used continuously.

This particular sort of tool is also made with a single bit, which is heated by a gas flame in the same general way. When desired hatchet bits are provided, either singly or in pairs, attached similarly to the fluted bits described. By the use of these irons no furnace is needed; all that is necessary being a gas jet within reasonable distance of where the work is done. It will be seen that one of these double irons serves the same purpose as two ordinary irons, for one bit is always being heated while the other is in use. It is stated that the consumption of gas by these soldering irons is only one cubic foot per hour, and that a cold bit can be heated ready for use in three minutes. The simplest way of holding the iron when in use and for first heating is to rest it in a block of wood about 4 inches square, with a V-groove in it large enough to hold the pipe. The Economic Soldering Iron has been used for some time in Europe, and a number of testimonials to its merits are given by English stained glass workers and others.

Pipe Wrench Converter Attachment.

The pipe wrench attachment herewith illustrated is being put on the market, as a novelty, by the Armstrong Manufacturing Company, of Bridge-

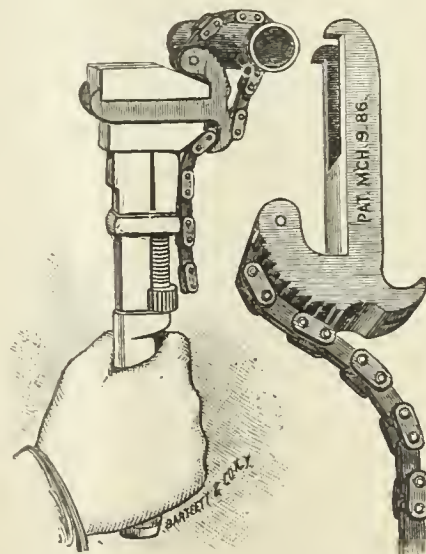

Pipe Wrench Attachment.

port, Conn. It constitutes a pipe wrench attachment for monkey wrenches, and, being made of forged steel, is not only light, but strong and durable. It changes a monkey wrench into a device for round surfaces in the shortest

possible time. The present size manufactured by the Company is calculated for 10-inch wrenches, and pipe capacity ranges from $\frac{1}{4}$ to $1\frac{1}{2}$ inches. The operating principle is similar to that of the chain-tongs. Samples, sent by registered mail, will be forwarded to any address by the Company on receipt of \$1.20.

Notes from the West.

By RETORT.

"The electric light has come to stay!"

Certainly; so has \$ gas.

The recent issues of the various gas journals contained matter that must have proven exceedingly palatable reading to the benevolent manufacturers of electric apparatus. One would suppose that a universal scramble for electric plants was in progress, and that the time was now here when consumers could obtain quotations from the "Light Office" for arc or incandescent electric, or plain, but far superior, gas illumination; and that gas engineers who did not "hustle" to get into the combination scheme were in danger of being "left." Is there not a suspicion that there lurks behind this whole matter a shrewd little boom for the benefit of the manufacturers of electric light apparatus, and that the real interpretation is, "The (boom of the) electric light (manufacturers) has come to stay?"

Apparently the electric boom is superseding the water gas boom. A quarrel seems imminent between some of the supposed gas journals as to which discovered the combination scheme! It reminds one of the next issues of local papers after a reduction in gas rates; each claims the honor of doing it, while withering editorials denounce the contemporary for his mercenary shielding of the octopus gas monopoly. The gas engineer could probably tell you that a reduction would have been made long before were it not for the anatomical display of the editors.

Now, our gas journals coolly inform us we must hustle on the fence, so as to cover both sides of the question, and dispense both kinds of light. In other words, we must "eat crow," and that as speedily as practicable. It is small wonder that the pioneer GAS LIGHT JOURNAL was slow to "come over," as a rival journal so gleefully puts it. The chasm was a terrific one to cross. All the teachings of recent years, by the brightest lights of the profession, must thereby be ignored; and above all, to "come over" means that the prime leaders of gas intelligence—the editors of all the journals—themselves must thereby stand self-confessed as cruelly mistaken, or, worse still, blinded by a loyalty to the industry of gas lighting. The gas man is bewildered by the rapidity of the evolution. What has brought it about? It is no argument to say, "The electric light has come to stay." Of course it has; and so has water gas; but we are not running over each other in our desire to secure a water gas plant. We are familiar with the singular anomaly of water gas people operating coal gas plants. This proves the *staying* qualities not of paramount importance.

The question is not, "Has the electric light come to stay?" but "Has it come to *supersede* gas?" Convince the gas men of the country of the latter, and the manufacturers turning out electric apparatus could run night and day for years and still have unfilled orders. The rush for plants would be tremendous. Now, we may be mistaken, but we do not remember to have seen any arguments used in the gas journals regarding this matter except that "the tendency of the times seems to point toward combination," and that "the electric light has come to stay." Surely these are very meager arguments to advise so important a change upon.

How about the profit upon the investment? We are told the gas companies can operate an electric plant, in connection with their gas plant, for much less money than an independent electric light company. Undoubtedly this is true; yet we have been told, by several shrewd gas engineers who are now operating gas and electric plants combined, that *there is no money in the electric light*, but that it pays because it saves annoyance.

Investigation proves that, taking a period of two or three years' business, very few electric companies are making money—certainly nothing like the profit reaped in our own business. When you find an electric light company making and declaring fair and regular dividends, investigation will disclose some unusually favorable circumstance which accounts for the showing.

For instance, we know of a company furnishing arc lights at \$60 per year for street lighting, while only a few hours' ride brings us to another company that furnishes the same light at \$200 per year. Is it any marvel that the latter company makes money? Yet the engineer in charge of the former (both plants use gas and electricity combined) says it saves his company annoyance, and hence pays.

If the present boom is resting upon future improvements in electric apparatus we shall want to go slow. Nor is it enough to know that one or two prominent gas engineers have embraced the new faith, for dozens, equally wise, cling to their old creed until the new is proven to be a better.

ITEMS OF INTEREST FROM VARIOUS LOCALITIES.

IN CHARGE AT WINFIELD, KANSAS.—Mr. Geo. B. Burns, former lessee of the Princeton (Ills.) gas works, is now located at Winfield, where he acts as Engineer and Superintendent of the local gas enterprise. The gentleman is ardent in advocating Winfield's claims to future business advance and prosperity. In fact, he writes: "We have a live, thriving, booming city out here, and I am more than in love with it." Mr. Burns is shrewd and energetic; and we are pleased to know that he is so eligibly situated. Kansas coal is carbonized in the Winfield benches, and a yield of 4 feet per pound is obtained from it, no exhauster being used. The latter state of affairs ought to be remedied in short order, and we opine that Supt. Burns would not have great trouble in persuading Prest. Fuller of the economy attendant upon such a purchase.

IN RE THE PHILADELPHIA GAS WORKS.—On Feb. 3 final action was taken in the matter of the report presented some time since by the Finance Committee of the Philadelphia City Council. The Committee had asked to be discharged from further consideration of the proposal to lease the city gas works, but the Council failed to act decisively in the premises; and, in fact, it was charged that such delay arose from the desire of certain parties to keep the matter in abeyance until after the Philadelphia municipal election (that event occurred yesterday) had taken place, when the leasing project would be revived. However, on the date mentioned the Finance Committee's request "for discharge from further consideration," etc., was agreed to in both branches of Councils. Mr. Wannamaker ought to have credit for defeating the scheme, although it is pretty well understood that the schemers are not dead, but hibernating, so to speak.

TO IMPROVE THE PLANT.—We understand that the directors of the Pittsfield (Mass.) Gas Light Company will make extensive improvements on their plant during the coming season. It is also said that a project looking to the erection of an auxiliary water gas plant is under consideration; indeed, it would appear that the latter has been almost decided upon, because the discussion has approached the stage where the probable allotment of money for the purpose has been stated. We understand that \$10,000 will about cover the cost. If they do decide to try the hybrid principle it will be interesting to watch its effect on the succeeding number of State Inspector Hinman's annual report of average candle power. In 1886 the Inspector averaged the illuminating power of the Pittsfield Company's product at 19.4 candles; and we venture to assert that a similarly good showing will not be made if the "auxiliary plan" goes into effect.

ORDERED TO STOP THE LEAKS.—At a meeting of the Poughkeepsie (N. Y.) Health Board, held Feb. 4, Dr. Otis presented a resolution—it was subsequently adopted—ordering the Citizens Gas Company of that city "to repair a leak in its holder tank within ten days, under a penalty of \$100 fine, and an additional \$10 per day for each day beyond said time," etc. We suppose that the managers of gas companies in this State are already posted in regard to the following clause of the Penal Code; but we will, however, venture to repeat it. Section 390 of the Code says: "A person who throws or deposits gas tar, or the refuse of a gas house or gas factory, or any offal refuse, or any other noxious, offensive, or poisonous substance into any public waters, or into any sewer or stream running or entering into such public waters, is guilty of a misdemeanor."

SPRINGFIELD, MO., WHEELS INTO LINE.—Last December witnessed the completion of the improvements made on the manufacturing plant of the Springfield Gas Light Company. Instead of having said improvements the term "new plant" might better express the situation, for the Springfield folks now possess a complete 8-inch works. A Wilbraham 8-inch exhauster, a set of 10 by 12 purifying boxes, with hydraulic lift for same, and new connections throughout, make a very complete affair of the Company's possessions. On the 1st inst. a new scale of rates was decided upon. The figures are as follows: Gross price, \$2.50 per thousand; but payment within six days from time account is rendered secures the following rebate: A consumption per month running from 400 to 4,300 cubic feet, 5 per cent. off; 4,400 and 20,000 cubic feet per month, 10 per cent. off; 20,000 cubic feet and upward per month, 15 per cent. off. From the above it will be seen that no discount is allowed unless the monthly consumption figures up to at least 400 cubic feet. The prior gross charge was \$3 per thousand. The officers of the Springfield Company are: President, L. H. Murray; Vice-President, G. A. C. Woolley; Sec., Treas., and Supt., J. S. Ambrose. Mr. Ambrose ought to be a tolerably busy man.

CHEAPER GAS FOR ST. PAUL, MINN.—Mr. Ed. I. Frost, the wideawake Treasurer of the St. Paul Gas Light Company—he who last fall renounced the tenebrose ranks of the bachelors by joining the aureate roll of benedicts—has given proof that that corporation desires to keep pace with

the procession. We arrived at such conclusion upon reading the following circular, which bears an imprint of Mr. Frost's signature. The circular is dated Feb. 1, 1887. "On and after April 1, 1887, the price of gas delivered by the St. Paul Gas Light Company will be \$2 per thousand cubic feet, with the following discounts on all monthly bills paid at the office of the Company on or before the 10th day:

Monthly Consumption.	Discount.	Net Rate.
5,000 cu. ft.....	5 per ct.	\$1.90
5,100 to 15,000 cu. ft.....	10 "	1.80
15,100 to 40,000 cu. ft.....	12 "	1.76
40,100 to 80,000 cu. ft.....	20 "	1.60
Over 80,000 cu. ft.....	25 "	1.50

Gas supplied to move gas engines will be charged for at the lowest net rate.

LOST AND FOUND.—Mr. and Mrs. Emerson McMillin, of Columbus, Ohio, have lost their charming daughter, Miss Mary Adelaide; but the friends of the "stricken parents" need not give way to woe over the matter, for the loss is merely a question of name instead of in fact. What proved loss to the McMillin household, however, turns out to be gain to the erstwhile monotonous domicile of the Secretary of the Ohio Gas Light Association—Mr. Irvin Butterworth, also of Columbus, Ohio. The marriage was celebrated at Columbus on date of 1st inst. Still another case of Hymen's magic, in that that roguish rover can convert loss into gain, is afforded in the example furnished by certain marriage ceremonies performed at Indianapolis, Ind., on January 28th last, whereby Miss Minnie Dildine became the wife of Mr. J. W. Cowdery. The groom, it will be remembered, is Superintendent of the Jackson (Miss.) Gas Light Company.

Congratulation in either case is unnecessary; but let us hope that prosperity in its fullest measure will be the portion of the contracting parties.

NEW GAS COMPANY.—Messrs. Wm. Budge and Alexander Griggs contemplate the erection of gas works in Grand Forks, Dakota Ter. Grand Forks is the capital of county similarly named; is located on the Red River of the North, at a point about 25 miles west of Crookston, Minn.; and has a population of between four and five thousand inhabitants.

TO BE ABSORBED.—Arrangements have been perfected whereby the American Gas Company, of Phila., Pa., will assume control of the Elgin (Ills.) and Canton (Ohio) gas works. The Elgin plant will be absorbed in March, Canton following suit in April. The Canton purchase ought to be an extremely valuable one, for it is peopled by those who are thoroughly abreast of the times.

ANNUAL ELECTION AT DELAWARE, OHIO.—At the annual meeting of the stockholders of the Delaware Gas Light Company the following directors were chosen: Messrs. T. C. Jones, C. Hills, V. T. Hills, U. Little, and J. M. Kirby. At the subsequent meeting of the Board organization was thus effected: President, T. C. Jones; Vice-President, C. Hills; Secy. and Supt., C. M. Converse; Treasurer, The Delaware County National Bank.

PRICE CHARGED FOR "CARBON POINTS."—The *Electrician* says there are nine large companies engaged in the manufacture of carbons in the United States. Seven of these have recently entered into a mutual agreement respecting the price of their wares, and have issued a joint circular to their customers. The prices agreed upon are quoted, per thousand feet, as follows: $\frac{7}{16} \times 12$ -inch, at \$12; $\frac{1}{2} \times 12$ -inch, at \$15; and $\frac{5}{8} \times 12$ -inch, at \$25; shorter lengths and odd sizes in proportion, plus a stated percentage.

DEATH OF MR. CHRIS. OLSEN.—Gas men in the South and West will hear with regret of the death of Chris. Olsen. Deceased followed the apparently prosaic occupation of a master mason, his specialty being the setting of benches; but, prosaic or not, his work was a guarantee of his honesty and skill; and his career through life was that of a Christian gentleman. Deceased came to his end, on first inst., in Indianapolis, Ind., after a month of racking illness.

CHANGE OF MANAGEMENT.—Mr. Carroll Collins has succeeded Mr. James G. Miller as Manager, Secretary and Treasurer of the Green Bay (Wis.) Gas Light Company. Mr. Collins, however, retains his connection with the Murfreesboro (Tenn.) works. Mr. Collins has purchased a controlling interest in the Green Bay Company from the former proprietor, Mr. Samuel D. Hastings, Jr.

A QUEER EXPLOSION.—On the evening of February 8th the steamboat Jno. P. Thorn was lying to at the wharf at the foot of Third street, Pittsburgh, Pa., and everything seemed to be serene; but the serenity was short lived, for, without warning of any sort, a violent explosion occurred, and the steamer was enveloped in a sheet of flame. It seems that one of the large conduits employed in conveying natural gas across the bed of the Allegheny river is located close by the Third street wharf, and it has since

been assumed that a fracture in the pipe permitted an escape of gas which finally found its way to the furnaces of the steamer. Hence the rumpus. The captain and engineer (brothers respectively named Henry and Tillman New) were severely burned, and the vessel sustained damage amounting to \$500.

NOT QUITE SO DOLEFUL.—In our issue for January 3d, current year, appeared a letter from Mr. Robt. Bruco, Secretary of the Olympia (Wash. Ter.) Gas Company, that was rather doleful in tone; but the following "notes," sent to us by "B," of the Walla Walla (Washington Territory) Gas Company, are in somewhat livelier strain. "B" thus discusses the situation: "Washington Territory having made its debut in your columns, perhaps some of your readers may be sufficiently interested in the premises to afford it another hearing. This time it shall be about the 'Inland Empire,' instead of 'down by the sounding sea;' and the change of venue may be classified under the title of 'Wheat vs. Clams.' Spokane Falls is a thriving young city, containing about 4,000 population, situate on the Northern Pacific Railroad, 374 miles eastward from Portland, Oregon—the metropolis of the Northwest. An unlimited water power is the boast and principal basis of prosperity of this inland city. This power is at present partly utilized by flour and lumber mills, and furniture manufacturers; and, last but not least, by an electric light company, which supplies the 'half are' and 'whole' incandescence lamps. With all these, however, the people were not happy; and because they could not claim full metropolitan attainment without a gas works. So the city fathers have not hesitated to grant a gas franchise to the first aspirant for same. One precocious youth seemed about to gratify their longings. Having obtained possession of a 'lot,' he purchased brick, etc., and proceeded to erect the required buildings, the walls whereof now stand at an altitude of ten feet. He caused a forty-foot hole to be sunk, and then, as some of the 'friends' wanted a little coin to meet current expenses, he incontinently skipped out (of the town, not the hole), and about \$3,000 worth of creditors 'mourned man's folly.' Meanwhile Spokane continued to expand, and the 'long-felt want' remained unsatisfied. A Walla Walla man, possessed of some gaseous ideas, asked the privilege of competing with the electric light promoters. At the same time an ex-railroad man, and some other capitalists resident in Spokane, concluded that the gas business might pay; and, thinking thus, asked why should an outsider be allowed to get a good thing while they were about? The authorities wrestled with this problem for some two moons, and finally settled it by granting to both applicants the privileges sought for. In the bargain the minimum charge for gas was fixed at \$4 per thousand cubic feet. And now came along Messrs. McDonald & Co., of Cincinnati, Ohio, who proposed to erect a gas works, and offered to supply private consumers with a 16-candle power gas at a rate not to exceed \$3 per thousand, also agreeing not to charge large customers more than \$2.50 per thousand. Street lamps were to be supplied with gas in consideration of the payment of \$2.50 per lamp per month. Their proposition took the fort by storm, for at the next meeting of the Council the previously adopted ordinances were repealed, and McDonald & Co. carried off the prize. So, another gas light will soon shine in the far West.

"Query for information. Do electric lighting companies—those engaged in *selling light only*—ever pay legitimately-earned dividends? We know that manufacturers and promoters must make money; but do local investors?"

ANNUAL ELECTION.—At the annual election of the Evansville (Ind.) Gas and Electric Company Messrs. F. J. Reitz, D. K. Dunkerson, S. Bayard, T. Garrin, W. Heilman, J. Eichel and Jno. Gilbert were elected a Board of Directors. At the organization meeting the officers who served last year were reappointed.

SOMETHING FROM PADUCAH, KY.—Since the purchase of the old Paducah (Ky.) Gas Company's plant, made by Evansville, Ind., capitalists, the business increased to such an extent that the present owners were compelled to build a new eight-inch coal gas works. The plant was constructed under the supervision of Mr. Isaac C. Baxter, Engineer of the Evansville (Ind.) Company, through whose courtesy we are enabled to place the following particulars before our readers. The new Paducah retort house contains one bench of sixes, the retorts of which are 16" \times 30" \times 10 feet, and equal to a carbonizing duty of 2,000 pounds of coal each 24 hours. There is a supplementary bench of threes, the construction of which permits its subsequent alteration to a bench of sixes, equal to burning off 1,000 pounds of coal in 24 hours. The retorts, etc., were supplied and erected by the Parker-Russell Company, of St. Louis, Mo. Other plant items comprise a set of annular condensers and scrubbers; an 8-inch Smith & Sayre exhauster with Greenfield engine; and a set of four 9-foot square purifiers. The station meter, gauges, and Foulis governor were furnished by Helme & McIlhenny, of Philadelphia, Pa. A contract for the erection of a new 70,000 cubic foot capacity holder has been awarded to Messrs. Deily & Fowler, of Phila., Pa., and it will be ready for use by next May. The works are quite ornate in external appearance, and the grounds enclosing them are tastefully laid out.

In fact the establishment is now one of the features of the city. At the last annual election the stockholders designated Messrs. Jno. Gilbert, R. K. Dunkerson, F. J. Reitz, J. Cobb, C. Reid, Isaac C. Baxter and L. Lowenthal a Board of Directors, Mr. Gilbert having subsequently been chosen President. The Superintendent's berth is filled by Mr. H. H. Meyers, who for years had been in the employ of the Louisville (Ky.) Company. Before the Paducah Company changed hands it was in pretty bad odor with the people of that city, but the business-like course of those now in control of its fortunes dissipated speedily the prejudice of former days. To prove this we have only to mention that the city recently entered into a contract with the Company, the latter agreeing to light 245 public lamps, for four years, at the stated price of \$22.50 per lamp per annum. Prior to the making of that contract Paducah had been without gas in her street lamps for several years. Further, the number of consumers now on the ledgers of the Company is twice as large when compared with the showing made by the final account books of the former owners. Virtue, we are told, carries its own reward, but the best reward of the business man is gained by a strict adherence to business principles.

FURBISHING UP AT KANSAS CITY, Mo.—The Kerr-Murray Manufacturing Company, of Fort Wayne, Ind., is under contract to furnish wrought iron roof, beams, cast iron floor and elevator for the new retort house—the dimensions of the latter being 67 by 100 feet—now in process of construction by the management of the Kansas City Gas Light and Coke Company. The same contractors will also furnish that Company with all the wrought and cast iron work necessary to equip a stack of 18 benches of sixes, to be fired on the regenerative principle; also one set of four cast iron purifying boxes, 16 feet square, with 16-inch connections.

RE-ELECTED.—Mr. Thos. F. Rowland, at the annual meeting of the Society of Civil Engineers, was re-elected to the Vice-Presidency of that body. The Membership of the Society has reached the imposing total of 1,019.

THE "EXCLUSIVE FRANCHISE" WAS SUSTAINED—We learn that the case of the Springfield (Mo.) Gas Light Company against the Springfield Electric Light Company was decided (on Jan. 26th, by Judge Hubbard, of the Circuit Court) in favor of the plaintiff. In 1874 plaintiff was granted an exclusive franchise for furnishing lights for street illumination for a period of 20 years. About a year ago the City Council contracted with the defendant to furnish 40 electric lights, to be properly distributed throughout the city, for the purpose of illuminating the public thoroughfares. The contract was to last for three years, and the contractor was to receive an annual payment of \$4,137. The Gas Company immediately took steps to enjoin the city from paying any moneys on account of the bargain. An injunction was issued in restraint, and Judge Hubbard now decides that the injunction must be made permanent. The electricians have supplied the lights for over a year, but have not received a payment. They will take an appeal.

NEW HOLDER FOR THE PITTSBURGH (PA.) GAS WORKS.—The Pittsburgh Gas Light Company has determined to put up a new telescopic gasholder. It will have a diameter of 100 feet, and two lifts, each of 28 feet. The Kerr-Murray Manufacturing Company will build it.

CHARTER EXTENDED.—After some delay and quibbling the Delaware State Legislature finally agreed to extend the charter of the Wilmington Gas Light Company, in accordance with the terms proposed in the prayer of the petitioner.

ORDINANCES, AND NO MISTAKE.—The following is a literal reproduction of an "official copy" of an ordinance proposed by the City Council of Eureka Springs, Ark.: "Sub. 52 Gas Light Companies.—For each gas light company engaging is the business of furnishing gas light to the city or its inhabitants, \$50 per annum, for business not to exceed \$10,000 and \$5 for each additional \$1,000 over \$10,000."

BROTHER PRICHARD IN TROUBLE.—On the evening of February 4th two employees of the Lynn (Mass.) Gas Light Company detected a leak in the meter room of the works, and, not satisfied to trust to their noses, one of the detectors struck a match to determine the thing certainly. His attempt was instantly successful and decidedly pronounced; for the news reports say one end of the house was shattered to fragments. Supt. Prichard ordered the gas supply to the town to be temporarily shut off; and as the accident happened at 8 P.M., much inconvenience was occasioned the consumers. The total damage to the Company is estimated at \$1,500. The chances are that Supt. Prichard will not have a berth for the "match striker," when the latter is discharged from the hospital where he now nurses his wounds.

ANNUAL ELECTIONS.—The Cambridge (Mass.) Gas Company has selected the following Board of Directors: Messrs. D. S. Tyler, Q. A. Vinal, C. C. Allen, W. A. Bullard, H. C. Rand, D. M. Chamberlin and F. M. Stimson.

The South Boston (Mass.) Company reports the following list: Messrs. B. Dean, S. Peirce, O. D. Dana, R. J. Monks, S. A. Stackpole and W. Eliot Fette. A dividend of 3½ per cent. was declared. At Manchester (N. H.) the directorate returned at the annual meeting is composed of Messrs. M. Currier, N. Parker, D. Clark, C. F. Warren and G. B. Chandler. In connection with the Manchester list it may be remarked that Mr. C. F. Warren is the only one of those named not entitled to the prefix of "Hon."

CUT DOWN.—The capital stock of the Ashtabula (Ohio) Gas Light Company has been reduced 50 per cent. It now stands at \$25,000.

ALMOST READY FOR BUSINESS.—The new plant at Marshall (Texas) is about ready to start on gas manufacturing. Consumers' meters have about all been located, and those interested in the enterprise have reason to be satisfied at the outlook for a fair return on the capital invested.

VERDICT FOR THE PLAINTIFF.—In the case of J. H. Skinner vs. the Boston Gas Light Company, the same having been an action brought to recover \$5,000 damages for injuries received by plaintiff in consequence of an explosion of gas at No. 17 Kilby street, where plaintiff was employed, the jury awarded plaintiff the sum of \$134.45.

THE COWBOY SECTION COULD NOT ASK FOR MORE.—It is reported that Sheriff Hugh Grant (whose chief claims to greatness consist in the possession of a more or less celebrated trotting horse, and the fact that he voted, as an Alderman, against the Broadway horse railroad steal), in company with Wm. Bourke Cockran (whose fame is securely grounded on the basis of having had his name affixed to the steeplechaser owned by his chum, Nolan, the Albany Solon), visited Albany the other day. The significance of the visit may be thus explained. They had in their possession a "little bill," which has since been introduced for passage at the hands of the present Legislature, the "strong points" of same being intended to compel "all corporations, joint stock companies and associations operating railroads in this State, or engaged in laying telegraph, telephone and electric light wires, or owning *gas pipes* or *other mains*, to hand over to the State, annually all profits which exceed 10 per cent. of their net earnings." The corporations are to report to the Comptroller annually the gross receipts, net receipts and the cash actually invested in the business. When a corporation reports that its income "is less than ten per cent., the officers of the company are to make a sworn statement to the Comptroller, and he is to investigate the books" of the concern, if he has reason to believe that the officers have presented a false report. An additional ten per cent. is to be added if the officers—well, we might just as well put it down so—are caught lying. The computations are to be based on cash investments. If a company refuses for three years to make a "proper report" its charter is to be forfeited, and its franchises are to revert to the State. A delegation from the wilds of cowboydom could hardly ask for anything neater than that proposed by the above-named strikers at monopoly. Indeed, were it not for the "singular personal and political purity"—a halo, so to speak—that surrounds, nay, permeates the character of the man who refused to give countenance or comfort to the famous Aldermanic "combine" of 1884, we might be forgiven for suspecting that the Sheriff was inclined to put himself in the market—possibly on joint account with Nolan's chum.

ELECTRIC LIGHT IN THEATERS.—Mr. F. Ross, in a paper read before the Vienna Society of Electricians, said that 30 theaters in Austria and Germany are lighted by electricity throughout. The light in the three theaters of Brünn, Prague, and Carlsbad had been established sufficiently long to form an estimate of its cost from actual practice, and it has been found that one electrical horse power per hour in these three instances is obtained with 8 lbs. of coal, 12½ lbs. of coal, and 37 cu. ft. of gas respectively. The working expenses for 1,000 ampere-hours, at 100 volts pressure, are, in Prague, \$6.50; in Brünn, \$4.50; and in Carlsbad, \$13.50. Sufficiently vague to be thoroughly indefinite!

THE OLD PITTSFIELD (MASS.) GAS COMPANY.—It has been rumored that an attempt would be made to secure the privilege of establishing an opposition company at Pittsfield, Mass. The reason therefor ought to be somewhat of a mystery, for, taken as a whole, the present management has done very well for the consumers. Inspector Hinman returns the average lighting value of the Pittsfield gas for 1886 at 19.20 candles, or the best gas sent out by any coal gas company in the State. The net rate charged is \$2 per thousand, and last year the total quantity manufactured was 14,276,000 cu. ft.; so the selling rate seems fair enough. The Company was organized in 1854, is capitalized at \$62,500, and shrewd valuers say that the present plant could not be duplicated for \$80,000. Looking over these facts we fail to see where there is need for a new company, and we also fail to perceive how an opposition combination could see its way clear to reaping either glory or shekels in attacking the present occupiers of the Pittsfield gas field.

WHAT BROTHER HUNT IS DOING AT MORRISTOWN, N. J.—Supt. H. M. Hunt is “booming” gas matters in the handsomest of New Jersey cities. About the first of the year his directors promulgated a rather novel schedule of rates—we are not certain, either, that the plan is a good one—the leading features of same being the following: Gas supplied to private dwellings is fixed at \$2.50 per thousand, but where the monthly consumption exceeds 5,000 cu. ft. a discount of 10 per cent. is allowed. To churches, public buildings, hotels, and stores the ordinary rate is fixed at \$2 per thousand, 5 per cent. discount being granted when the monthly consumption exceeds 10,000 cu. ft. Later on it was decided to make special rates for storekeepers who would agree to take gas at a contract price for the year. The storekeepers’ schedule was thus made out: A consumption not to exceed 50,000 cu. ft. per annum, total contract charge, \$90; 60,000 cu. ft., \$108; 70,000 cu. ft., \$125; 80,000 cu. ft., \$144; 90,000 cu. ft., \$162; 100,000 cu. ft., \$180. This plan was adopted in order to prevent a see-sawing move in the direction of electric light. Mr. Hunt having completed the conduit substitution on which he was engaged last fall, is much pleased with its operation; and so are his consumers. In November of 1886 the electric light folks commenced supplying a lighting current, and the following figures from the books of the gas company will show the effect exerted by the former on the business of the latter:

Date.	Gas Sentout.	Date.	Gas Sentout.	Increase.
Nov. '85..	903,000 cu. ft.	Nov. '86..	1,162,700 cu. ft.	259,700 cu. ft.
Dec. '85..	959,000 “	Dec. '86..	1,251,400 “	292,400 “
Totals..	1,862,000 “		2,414,100 “	552,100 “

We submit that the figures ought to satisfy Morristown’s shareholders. The Morristown Company will make extensive plant alterations in the coming season.

ANNUAL MEETING OF THE SAN FRANCISCO (CAL.) GAS COMPANY.—The annual meeting of the stockholders of this company was held on January 18th. The old Board of Directors, with the exception of T. Menzies, who was replaced by J. B. Randol, was re-elected. Mr. J. B. Crockett was re-elected President, and W. G. Barrett, Secretary. From the reports submitted we glean the following: The Company commenced the year without debt, and a good supply of coal. Regular monthly dividends (30 cents per share) were paid, and \$62,000 was invested in permanent improvements. The Equitable water gas patents were purchased at a cost of \$126,000, and \$81,000 has been paid on account of same, the balance (\$45,000) to come due in March next. The purchase includes all “improvements and reissues of patents.” Works, calculated to produce a daily output of 200,000 cubic feet of the Equitable sort of gas, have been erected at the “Protrero.” It is said that California petroleum can and will be utilized in the manufacture. The contract for supplying the public buildings of the city with gas for two years, was renewed last May, at \$1.75, as against \$1.25 for the two previous years. Contracts for lighting the public lamps for two years were renewed last August on satisfactory terms. The total number of street lamps lighted is 5,100, or the same as a year ago. The price of coal (a most important factor in San Francisco) last year was the lowest ever known, and the Company reaped the benefit thereof. Recently a satisfactory test was yielded by a trial of South Prairie coal, and the Company, in consequence, contracted for a supply of from two to three thousands tons per month of that variety at the figure of \$5 per ton; also for two thousand tons per month of Nanaimo coal, at \$6 per ton. The Company has now on hand 20,000 tons of coking coal, equal to four months’ supply, and a good stock of cannel is in store. Gas sales for the past year show a five per cent. increase over the figures for 1885; but the receipts on account of ammonia, coke and tar show a decrease. New meters to the number of 4,877 were placed during the year, and 3,749 were returned—a net gain of 1,128. The payments made by the city foot up at \$218,157, an increase of \$2,238. Salaries and wages during year absorbed \$368,692, a decrease of \$4,398. The Company is now in good financial condition.

WANTS AN ELECTRIC LIGHT PLANT.—Mr. Z. R. Brockway, General Superintendent of the State Reformatory, at Elmira, N. Y., acting on behalf of the Board of Managers of that institution, informs electric lighting plant contractors that sealed proposals will be received, until midday of March 15, at his office, for a complete electric lighting plant, the same to be erected in accordance with the specifications, to be furnished on application, and plans on file at the Reformatory. Bids must be accompanied by a certified check covering 25 per cent. of the face value of the proposition. The number of lights to be furnished is placed at 1,728 incandescent and 30 arcs.

NEW GAS COMPANY.—The Castleton (S. I.) Gas Light Company has just been organized. Among those interested are Messrs. Robt. Moore, George Bechtel, E. P. Doyle, E. Wygant, Mon. Eckstein, S. F. Rawson, E. C. Blackford, Daniel Pelton, C. E. Griffith, and H. D. Leslie. A pretty solid lot. The capital stock of the Company is placed at \$50,000. Castleton is

on the north shore of Staten Island, and embraces the villagos of Tompkinsville, New Brighton, Castleton Corners, etc. Sailors’ Snug Harbor is located there.

NUMBER OF PUBLIC LAMPS AT NORRISTOWN, PA.—Norristown, Pa., now maintains 126 gas and 88 oil lamps on her streets. During January 40 oil lamps were changed to the gas system.

REPAIRING THE BREAKS.—The earthquake experience of the Charleston (S. C.) Gas Light Company has so far caused to it a loss of about \$25,000. The repair gangs have detected and repaired over 500 leaks, and about 100 of these were caused by actual fracture of the conduits. It is estimated that the leakage at the present time is about 20 per cent. of the make.

DEPRIVED OF THEIR GAS.—The City Attorney of Muncie (Ind.), acting under orders from the Common Council, yesterday commenced proceedings to enjoin the Muncie Gas Company from running natural gas through its mains. The Council claims the company has no right under its franchise to furnish anything but coal gas, and that by furnishing natural gas it has forfeited its franchise.

NO ONE DOUBTS IT IN THIS ESTABLISHMENT.—Our Western correspondent, “Retort,” in his current batch of “Notes from the West,” affirms that “\$ gas has come to stay.” To which assertion we reply, “Of course.” And we will submit the further explanation that no one connected with 42 Pine street ever thought otherwise.

Correspondence

[The JOURNAL is not responsible for the opinions expressed by correspondents.]

“A. S.” is Not Convinced.

NEW YORK, Feb. 8, 1887.

To the Editor AMERICAN GAS LIGHT JOURNAL:

Allow me to say a few words concerning Mr. Egner’s reply to my notes on naphtha gas as an enricher.

I accept Mr. E.’s explanation as to obtaining 12,163 cu. ft. of gas from 2,240 lbs. of coal and 4.8 galls. of oil, instead of from 2,211.2 lbs. of coal and same quantity of oil, as I had understood it. I further note that his oil actually weighs 6½ lbs. per gall. instead of 6 lbs., as I had estimated. These corrections will, however, change my figures but slightly.

Under heading “Third” Mr. E. seems to charge me with misquoting his statement on the illuminating power of gas obtained from Youghiogheny coal alone in making it 17 candles. My quotation was, however, correct, as Mr. E. says, near foot of second column, page 363, issue of December 16, 1886: “The coal was again tested by itself and shown to produce 4.89 cu. ft. of 17-candle gas per pound.”

Allowing the above corrections, and assuming that every particle of the oil had been converted into a fixed gas (although this cannot be done), we have—

Gas from 2,240 lbs. of coal and 4.8 × 6½ = 30 lbs.	
of oil.....	12,163 cu. ft.
2,240 lbs. of coal Mr. E. reports to yield..	10,953 cu. ft.
The 30 lbs. of oil, converted into gas of	
0.850 density, will yield.....	460 “
	11,413 “

Gas unaccounted for..... 750 cu. ft.

The 750 cu. ft., Mr. E. explains, consists of gas saved and of air and furnace gases drawn in by over-exhaust. That there is no gain in the long run by over-exhausting and unsealing of dip-pipes has been demonstrated time and again. In a well ordered retort house, such as Mr. E. is probably possessed of, the amount of gas lost through leaky joints, the pores of retorts, etc., should be but trifling, and by far the largest portion of the above 750 cu. ft. would, then, appear to be air pure and simple. If this was not the fact what would prevent Mr. E. from using the same gas-saving over-exhaust when making coal gas alone, if not the fear of seeing the illuminating power go out of sight altogether?

The “enriching” process as practiced at the Laclede works seems to be the adding to the coal gas of a certain quantity of oil gas and a still larger quantity of air; but even if the volume of the latter was only equal to that of the former, or 50 per cent. of the “enriching” mixture, the illuminating power of this mixture would be, according to Mr. Farmer’s rule (the oil gas being 70 candles)—

$$\frac{50 \times 70 - 50 \times 50}{100} = 10 \text{ candles.}$$

The effect of enriching 17-candle coal gas with this 10-candle oil gas and air mixture must necessarily be in the retrograde direction.

Verify, if Mr. E.’s station meter is correct, then his photometer must need overhauling badly.

A. S.

The Market for Gas Securities.

Consolidated shares were strong and active at commencement of last fortnight, having sold up as high as 86½, but subsequent reaction caused a recession to 84½. To-day (Feb. 14) the market opened at 85, and the tone is steady. Equitable has been listed on the Exchange, and apparent sales were made as high as 117. The stock is steady to strong. Mutual has also developed some strength, and it would appear that these shares, at ruling quotations (103 to 105) ought to be a purchase. Brooklyn securities do not show any change of moment, but that is easily accounted for on the ground of the Albany doings. As before hinted in our market report, the Legislature does not seem inclined to make a lower compulsory rate for gas in the City of Churches than \$1.50 per thousand. In fact the Senate Committee that considered the Griswold bill reported back the measure with an amendment fixing the price at \$1.60. Nothing of interest from out-of-town. We would ask Secretaries of Companies which appear in our list to kindly furnish us occasional reports of late actual sales, in order that the given quotations may be authentic.

Gas Stocks.

Quotations by Geo. W. Close, Broker and Dealer in Gas Stocks.

16 WALL ST., NEW YORK CITY.

FEBRUARY 16.

All communications will receive particular attention.

The following quotations are based on the par value of \$100 per share.

	Capital.	Par.	Bid	Asked
Consolidated.....	\$35,430,000	100	84½	85
Central.....	440,000	50	30	—
“ Scrip.....	220,000	—	47	57
Equitable.....	2,000,000	100	115	117
“ Bonds.....	1,000,000	—	113	115
Harlem, Bonds.....	170,000	—	—	—
Metropolitan, Bonds...	658,000	—	110	113
Mutual.....	3,500,000	100	103	105
“ Bonds.....	1,500,000	1000	101	—
Municipal, Bonds.....	750,000	—	—	—
Northern.....	125,000	50	36	—
“ Scrip.....	108,000	—	—	—
Yonkers.....	—	50	51	55
Richmond Co., S. I.	300,000	50	50	—
“ Bonds.....	12,000	—	—	—
Gas Co's of Brooklyn.				
Brooklyn.....	2,000,000	25	104	—
Citizens.....	1,200,000	20	—	68
“ S. F. Bonds....	320,000	1000	—	103
Fulton Municipal.....	3,000,000	100	135	—
“ Bonds....	300,000	—	—	106
Peoples.....	1,000,000	10	54	56
“ Bonds.....	290,000	—	100	—
“ “.....	250,000	—	100	—
Metropolitan.....	1,000,000	100	78	80
Nassau.....	1,000,000	25	102	104
“ Ctfs.....	700,000	1000	100	—
Williamsburgh.....	1,000,000	50	125	—
“ Bonds...	1,000,000	—	107	—
Out of Town Gas Companies.				
Boston (Mass.) Gas Co.	2,500,000	500	870	875
Buffalo Mutual, N. Y...	750,000	100	90	95
“ Bonds...	200,000	1000	95	100
Citizens, Newark.....	1,000,000	50	140	145
“ “ Bonds.	45,000	—	—	—
Chicago Gas Co., Ills...	5,000,000	25	142	145
Peoples G. L. & C. Co.,				
Chicago, Ills.....	3,000,000	—	29	31
Cincinnati G. & C. Co..	6,000,000	100	183	185
Consolidated, Balt.....	6,000,000	100	60½	—
“ Bonds....	3,600,000	—	107	107½
Chesapeake, Balt.....	1,500,000	100	79	80
“	1,000,000	—	100	102
Consumers Toronto....	1,000,000	50	194½	196½

Central, S. F., Cal.....		82½	84
Capital, Sacramento, Cal.		55	58
Hartford, Conn.....	750,000	25	140 142
Jersey City.....	750,000	20	155 —
Laclede, St. Louis, Mo.	1,600,000	100	110 112
Louisville, Ky.....	1,500,000	50	113½ 115

WANTED,

By the Chesapeake Gas Company, of Baltimore City. AS GENERAL FOREMAN OF ITS GAS WORKS, a first-class man, engineer, and mechanic; one who has had experience, and thoroughly understands steam, and who is absolutely temperate and sober. Address, with references, A. B. PROAL, Sec. Chesapeake Gas Co., Baltimore, Md.

Superintendent's Position Desired

By a practical man of twenty-five years' experience in the manufacture and distribution of coal and water gas. Satisfactory references given. Address 646-4f “ENGINEER,” care this Office.

THE GLOBE STREET LAMP.



MINER'S PATENT STREET LAMPS.

Are adapted for use of Streets, Parks, Depots, Ferries, & Private Grounds.

WITH POSTS OR BRACKETS.

Jacob G. Miner,

No. 823 Eagle Ave., New York N. Y.

FOR SALE, Ten No. 2 Siemens Regenerative Gas Lamps, With Factory Fixtures and Reflectors complete and in order. Only used three or four months. Will be sold cheap. DANVILLE NAIL AND MFG. CO., Danville, Pa.

ENGLISH “Journal of Gas Lighting.”

Issued weekly. New volume commences Jan. 1, 1887. Price, \$7 per annum. Subscriptions taken by

CHARLES NETTLETON, Agent for U. S., No. 115 BROADWAY, N. Y. CITY.

JARVIS ENGINEERING CO.,

61 Oliver St., Boston, Mass.

CONTRACTORS FOR ERECTING

COMPLETE STEAM OUTFITS FOR ELECTRIC LIGHTING STATIONS.

Steel Boilers set with Jarvis Pat. Boiler Setting,

To burn COKE SCREENINGS for Fuel.

ARMINGTON & SIMS CO. ENGINES,

Belting direct to Dynamos, without using Shafting.

SEND FOR CIRCULARS.

GEROULD'S IMPROVED RETORT CEMENT.

A Cement for patching retorts, putting on mouthpieces, and making up all bench-work joints. This Cement is mixed ready for use. Economic and thorough in its work. Fully warranted to stick. For recommendations and price list address

C. L. GEROULD, Manchester, N. H.

Western Agent, H. T. GEROULD, Mendota, Ill.

Ferric Oxide for Gas Purification.

Ferric Oxide, as ground, screened, and prepared by me for purifying purposes, has now been in use for several years by many of the gas works throughout the country, including Detroit, Chicago, Milwaukee, East Saginaw, Burlington (Iowa), Ann Arbor, etc. It has proved, as I believe, the Most Effective and Economical Agent now in use. I am prepared to furnish the Oxide by the 100 lbs. or in car load lots, and will be pleased to give price f.o.b. cars at Ann Arbor or at place of destination. Address

S. H. DOUGLAS, Prest. Ann Arbor (Mich.) Gas Light Co.

CHURCH'S REVERSIBLE SCREEN FOR GAS PURIFIERS

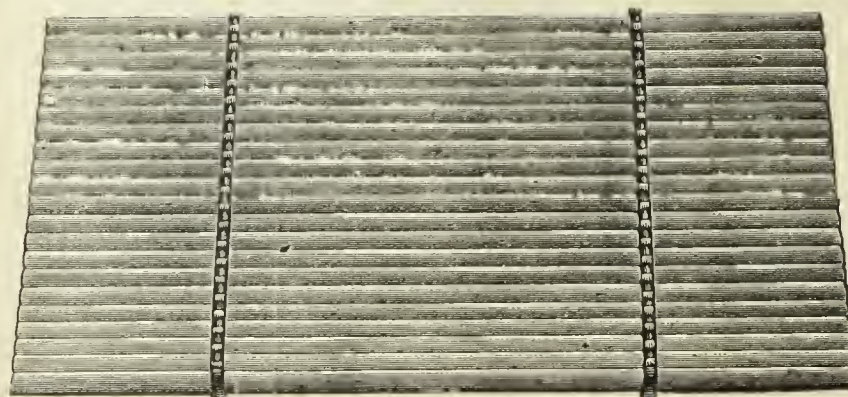

Very Durable Easily Repaired.

Oval Slats, with Malleable Iron Cross Bars.

Apply to

JOHN CABOT,

306 to 310 11th Av., N. Y.

PATENTED JULY 9, 1878.

References in all parts of the country. Send for circular and list of companies who now have the Screen in use.

Kloenne & Bredel Improved REGENERATIVE FURNACES

Self-Sealing Mouthpieces and Bridge Pipes,
RETORT HOUSES, WASHER-SCRUBBERS,
GASHOLDERS, AND GAS WORKS COMPLETE.

Our system of heating retorts by regenerative furnaces is the simplest, most economical, most durable, and cheapest of any in use. It is the only regenerative furnace used to any extent in Great Britain, where several thousand retorts are working at the present time. In Birmingham alone 952 retorts were erected, and they are giving the best satisfaction ever obtained from any regenerative furnaces. The great advantages our benches have over all others are the following:

The generator and regenerator are independent of each other, so that any contraction or expansion of one will not interfere with the other.

The superheating surface is greater than in any other furnace yet constructed. The regenerator is absolutely self-tightening, and cannot get out of order.

The thickness of material between the waste gases, secondary and primary air is only 1½ inches, which increases the regenerative power from 100 to 500 per cent.

The generator is working absolutely cold, and therefore is not liable to any perceptible wear and tear.

The grate, having an enormous surface, allows the use of an inferior fuel, such as breeze, fine coke, or slack coal.

Clunkers are never formed. By an ingenious arrangement of mixing air and the steam produced by the cooling water all incombustible materials in the fuel are formed into soft ashes.

The waste gases go up through flues at 400° to

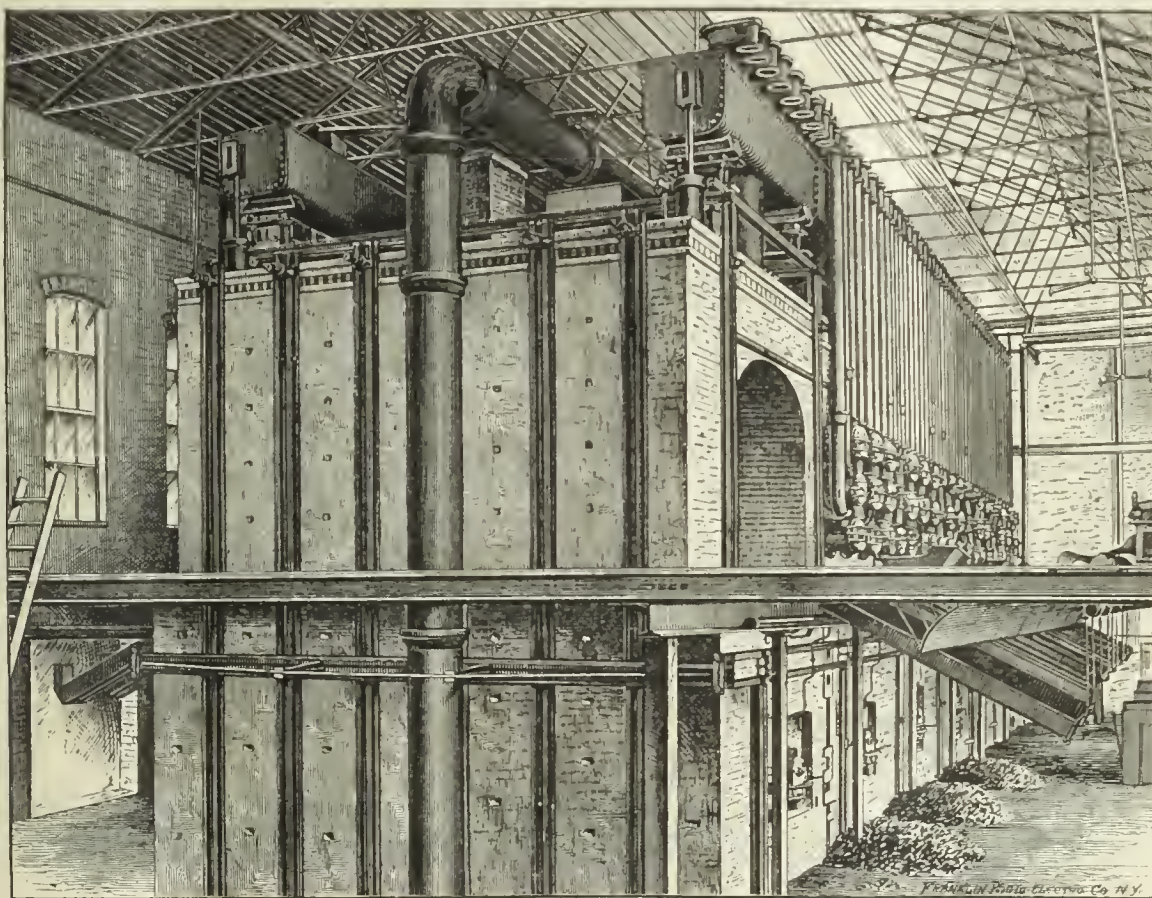

500° F. No large chimneys are required.

No cold air can enter; consequently no cracking of retorts.

The generator is inside of bench, thereby preventing any loss of heat; and stokers do not have to stand on a hot floor, as is the case where the generator projects outside of the bench.

In the past two years more than 500 retorts, with a capacity of five million cubic feet of gas per diem, have been erected in this country, and these are giving the best satisfaction, as the following testimonials will show.

We also construct half-regenerative benches, which will give the best results, and can be built in existing skeleton arches.

OFFICE OF THE NEWARK GAS LIGHT COMPANY, NEWARK, N. J., January 28, 1887.

MR. FREDERICK BREDEL, General Agent Kloenne Regenerative Furnace:

Dear Sir—The Kloenne Furnaces erected by you have been in continuous use for more than a year, and continue to give us satisfactory results. We are carbonizing 1,800 pounds coal per retort in 24 hours, and the average fuel consumption for this much has been 16.8 pounds by volume of the coke produced, or 100 pounds coal have been carbonized by 11.25 pounds hot coke. We have not lost a retort yet, and I think that those in use will give us six months' more service.

Very truly,

[Signed] EUGENE VANDERPOOL.

ENGINEER'S OFFICE, MILWAUKEE GAS LIGHT COMPANY, MILWAUKEE, WIS., January 26, 1887.

FRED. BREDEL, C.E.: Dear Sir—Upon your request for a testimonial for publication, I am pleased to send you the following, as I consider it deserved for the way in which your contract was carried out with us. I would say to any in the profession that among all the plans of benches presented to me from which to select I chose the "Kloenne" for several reasons. I considered it perfect in principle, that at all times it would be under absolute control, and also that each block in the regeneration could be easily seen and repaired if necessary. Your work upon our benches was done as good as it possibly could have been by anyone, and such has been the opinion of the several visitors during the progress of the work and since its completion, without exception. We have been running the furnaces since Oct. 6, and as yet have observed no cracked or sagged retorts. Every part of the work appears as perfect as when set. Although the first month was used up in experimenting and learning how to run the furnaces, and since that time we have experienced very cold weather, yet we are selling 26 bushels of coke (40 lbs. per bushel) per net ton of coal used. The consumption of coke in the furnaces does not exceed 20 per cent. at the present season, and for the year I am sure will be materially less.

Yours truly,

[Signed] E. G. COWDERY.

OFFICE OF THE CHICAGO GAS LIGHT AND COKE COMPANY, CHICAGO, ILL., January 27, 1887.

FRED. BREDEL, Esq.: Dear Sir—We have had eight benches of nines with the Kloenne furnaces running continuously for 13 months. The results have averaged 9,000 cubic feet per mouthpiece in 24 hours, with a fuel consumption of 13 pounds coke per 100 pounds coal carbonized.

Yours truly,

[Signed] THEOB'D FORSTALL, V.-P.

For further information apply to

FRED. BREDEL,
332 East 17th Street, N. Y. City. } OR { **G. F. KREISCHER,**
132 Mangin Street, N. Y. City.

GIBBS PORTLAND CEMENT

Is guaranteed to be the finest English brand, and unsurpassed by any grade imported for making concrete and setting masonry. Extract of Paper, with tests, read before the American Society of Civil Engineers, sent on application.

HOWARD FLEMING,
Sole Agent for U. S.,
23 Liberty St., New York.

MITCHELL, VANCE & CO.,
MANUFACTURERS OF

Chandeliers

and every description of

GAS FIXTURES.

Also manufacturers of Fine Gilt Bronzes and Marble Clocks, warranted best time-keepers. Mantel Ornaments, etc.

Salesrooms, 836 Broadway, N. Y.

Special Designs furnished for Gas Fixtures for Churches, Public Halls, Lodges, etc.

HOWARD FLEMING,
23 Liberty St., New York.

IMPORTER OF

"BRIDGEND" "DINAS"

Silica FIRE Bricks

FOR COKE OVENS AND GAS WORKS.
PORTLAND AND ROMAN CEMENTS.
Correspondence Invited. Lowest Prices.



STEPHEN A. MORSE, President.
GODFREY REBMANN, Vice-Pres.

M. B. DYOTT,
Superintendent.

EDWIN F. MORSE, Secretary.
CARLTON M. WILLIAMS, Treas.

STANDARD GAS LAMP CO.,

Office, 411 Cherry St. Factory, 1101, 1103 & 1105 Frankford Av.

Philadelphia, Pa.

It is to the interest of Gas Companies and Cities to use Dyott's Patent Champion Lamps, which give double the light with the same consumption of gas, and will save 50 per cent. over others in cost of keeping in repair. Gas Companies and others intending to erect Lamps of any description will do well to communicate with us. Special Drawings furnished and Estimates given on application upon Architects', Engineers' or our Draughtsmen's Plans.

Our Patent System of Instantaneously Lighting Gas (without electricity) for R. R. Depots is unequalled. Our High Candle Power Burner is superior to the Electric Light or any other High Candle Burner. We manufacture every description of Ornamental Lamps.

Gregory's Retort Incandescent Gas Lamps.

Manufactured under Patents granted and applied for. Over 20,000 sold in New York and Brooklyn. Over 100,000 sold in the U. S. in one year. It is the only lamp that can compete with Incandescent Electric Light. Gas Companies should see that it is on sale in their city or town. They can be attached to any bracket or fixture. A Complete Revolution in Gas Lighting. The invention of GEO. H. GREGORY, Gas Expert. A pure white light obtained from Gas, which is Superior to Electric Light. All lamps are finished in nickel plate. The construction of all lamps allows the gas to be superheated before passing through the tip, rendering the illuminating properties of the gas incandescent, which causes the Brightest Light ever obtained from Gas. Lamps made in all sizes. Gas Companies should assist in introducing this new lamp, which exceeds all other devices for gas lighting. This Cut represents Office and Bracket Lamp. Price, \$18 per dozen; discount 50 per cent. in half dozen lots or more. Send for Catalogue. Address

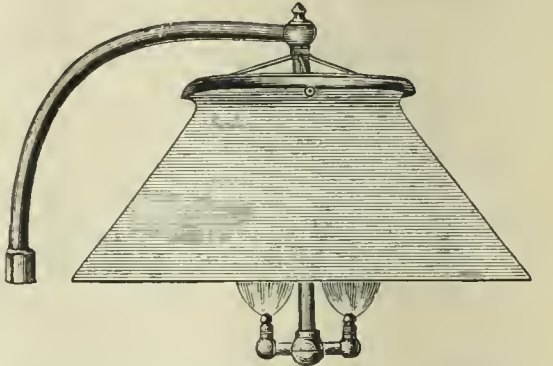

GEO. H. GREGORY, Mnfr., 337 Broadway, N. Y.

GASHOLDER TANK CONSTRUCTION, ETC.

Gas Companies and others about to erect Gasholders will find it profitable to consult W. C. WHYTE, who for over thirty years has made a speciality of

Holder Tank Excavation and Mason Work.

Fifty tanks now in operation show the sort of work done. Address

W. C. WHYTE, No. 15 Cortlandt St., N. Y. City.

DURING THE PAST YEAR, THE

NATIONAL GAS LIGHT AND FUEL CO.

218 LA SALLE ST., CHICAGO,

Have Erected Twelve Sets of Water Gas Generating Apparatus under the Springer Cupola System. They are as follows:

- Newton Illuminating Company, Newton, Kansas.— Daily capacity, 120,000 cu. ft.
- Wellington Light & Heat Co., Wellington, Kansas.— Daily capacity, 120,000 cu. ft.
- Chippewa Falls, Gas Light Co., Chippewa Falls, Wis.— Daily capacity, 120,000 cu. ft.
- Elkhart Gas Light & Coke Co., Elkhart, Indiana.— Daily capacity, 120,000 cu. ft.
- Madison City Gas Light Company, Madison, Wis.— Daily capacity, 120,000 cu. ft.
- South Bend Gas Light Co., South Bend, Indiana.— Daily capacity, 250,000 cu. ft.
- Sheboygan National Gas Comp'y, Sheboygan, Wis.— Daily capacity, 120,000 cu. ft.
- Salina Gas Light Company, Salina, Kansas.— Daily capacity, 120,000 cu. ft.
- Rathbun Company, Deseronto, Province Ontario.— Daily capacity, 80,000 cu. ft.
- Jefferson City Gas Light Co., Jefferson City, Mo.— Daily capacity, 120,000 cu. ft.
- Mankato Gas Light Company, Mankato, Minnesota.— Daily capacity, 80,000 cu. ft.
- Minneapolis Gas Lt. & Coke Co., Minneapolis, Minn.— Daily capacity, 1,000,000 cu. ft.

1886

1886

THE ALBO-CARBON LIGHT.

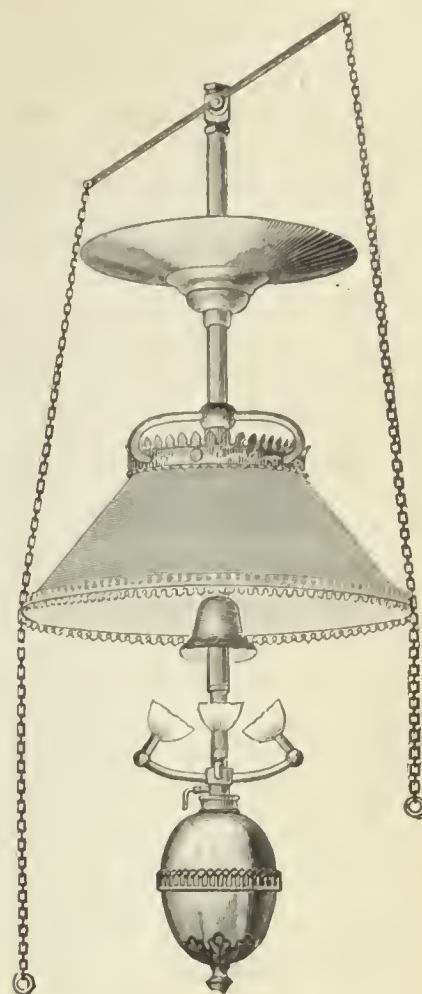
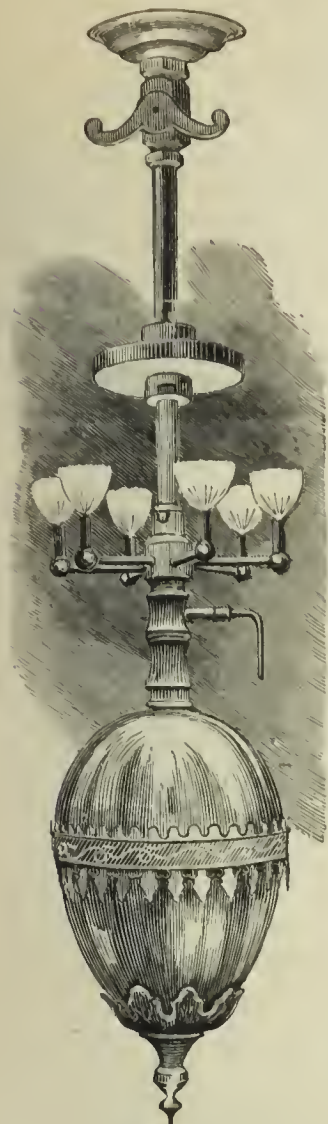

This most successful of all methods of enriching gas is based on the use of heated gas to vaporize a solid hydrocarbon, thus

COMBINING THE ADVANTAGES OF PREHEATING AND CARBURETTING.

The incoming gas passes over an extended heating surface (heated by means of the illuminating flames), and is raised to the temperature necessary to vaporize the carburetting material, which is a white, crystalline solid prepared from coal tar.

INJUNCTION CRANTED!

In the suit between this Company as complainant and Newman A. Ransom and the Chicago Gas Apparatus Manufacturing Company as defendants, pending in the Circuit Court of the United States for the Northern District of Illinois, on a late hearing of said cause before his Honor, Judge Gresham, Judge of said Court, an order was made and entered therein, a copy of which is hereto annexed, supporting our charge of infringement of our Letters Patent No. 247,925, dated Oct. 4, 1881, and of our Letters Patent No. 333,862, dated Jan. 5, 1886, and sustaining our rights under said several Letters Patent, to which especial attention is hereby directed, viz.:

UNITED STATES CIRCUIT COURT,
Northern District of Illinois.

WALTER J. KIDD

vs.

CHICAGO GAS APPARATUS MANUFACTURING
COMPANY AND NEWMAN A. RANSOM.

In Equity.

The Bill of Complaint and the affidavits filed by the respective parties having been read and the arguments of the counsel for the respective parties having been heard and duly considered by the Court—C. K. Offield, Esq., of Offield, Towle & Phelps, for the Complainant, and John H. Whipple, Esq., of Merriam & Whipple, for the defendants—and it appearing that Letters Patent of the United States were issued in due form of law to Joshua Kidd, No. 247,925, dated October 4, 1881, for an Improvement in Apparatus for Enriching Gas, also Letters Patent of the United States to said Joshua Kidd No. 333,862, dated January 5, 1886, for an Improvement in Carburetting Attachments for Gas Fixtures, and that the title to said Letters Patent vests by mesne assignments in the complainant herein; and it appearing by the answer of the defendant corporation, the Chicago Gas Apparatus Manufacturing Company, that they have never

manufactured, used, or sold, or had anything whatever to do with any so-called apparatus for enriching gas of any kind or description whatever, or any carburetting attachment for gas fixtures of any kind or description whatsoever; and it appearing that said defendant, Newman A. Ransom, has infringed the second claim of said Letters Patent No. 247,925, dated October 4, 1881, and the first and second claims of said Letters Patent No. 333,862, dated January 5, 1886, by manufacturing and selling carburetting attachments for gas fixtures manufactured according to said Letters Patent contrary to the form of the statute in such case made and provided;

Now, therefore, it is hereby ordered, adjudged, and decreed, this 30th day of December, A. D. 1886, that an injunction be issued pursuant to the prayer of the Bill herein, strictly commanding and enjoining the said defendant, Newman A. Ransom, his clerks, attorneys, agents, servants, and workmen that they forthwith, and until the further order, judgment, and decree of this Court, desist from the making, using, or selling of any carburetting attachments for gas fixtures substantially as described and claimed in said Letters Patent in said above identified claims thereof; and that the complainant enter into Bond to be approved by the Clerk of said Court in the penal sum of two thousand dollars (\$2,000), to said defendant, Newman A. Ransom, conditioned to pay the defendant or his legal representative all such costs and damages as shall be awarded against the complainant in case the said injunction shall be dissolved, said Bond to be filed on or before the 22d day of January, 1887.

and our suit against W. S. Horry (trading as the Crystal Carbon Light Co.), Arthur Kitson (trading as Kitson & Co.), and others, defendants, for infringement of our Letters Patent above mentioned and referred to, pending in the Circuit Court of the United States for the Eastern District of Pennsylvania, has not yet been reached for hearing.

THE ALBO-CARBON LIGHT COMPANY, - - - NEWARK, N. J.,
Sole Manufacturers for the United States.

GAS ENGINES.

GAS LAMPS.

BOOKS.

THE CLERK GAS ENGINE CO.,

Main Office, 1012, 1014, 1016, 1018 Filbert St., Philadelphia, Pa.

WM. W. GOODWIN, Prest.

E. STEIN, Sec.

S. LEWIS JONES, Asst. Sec.

A. J. DOTY, Supt.

The utility and convenience of the Gas Engine being no longer an open question, it only remains now for intending purchasers to select the BEST. We claim for the CLERK GAS ENGINE that it is equal to any other manufactured as regards steadiness in running, simplicity, and ease of keeping in repair, and that it gives the greatest amount of power for the least money (both in first cost and expense of running) of any engine made. In support of this claim we refer to the test of the Gas Engines made under the direction of the American Institute of New York, in December, 1885, and heretofore published in these columns. These engines are especially adapted for continuous running under heavy loads, and we can refer to Engines which have run 22 hours a day for months at a time.

Made in Sizes of 5, 10, 15, 20, and 25 Horse Power. All Engines Guaranteed for One Year.

TRADE MARK.

THE CRYSTAL CARBON LIGHT!

The Latest and Most Improved Gas Light!

ADAPTED FOR PRIVATE RESIDENCES, CHURCHES, THEATERS, STORES, ETC.

These Burners are manufactured on the principle of enriching gas by means of Naphthaline (so-called Crystal Carbon or Albo-Carbon), the invention of the Rev. W. R. Bowditch, F.R.S., of Wakefield, England, who was the original inventor and patentee of this system of gas lighting.

SPECIAL NOTICE.

Many Gas Companies find the Crystal Carbon Light a valuable competitor against the Electric Light. It is ornamental, free from the defects common to all other enriching gas burners, and is as cheap as ordinary gas chandeliers. We sell direct to gas companies, giving them the benefit of agents' discounts.

CARBONCRYSTAL.

(Trade Mark.)

A new and superior preparation for enriching gas used in conjunction with Crystal Carbon or Albo-Carbon gas lights. The preparation is cleaner and better adapted for filling burner vessels than any hitherto produced. Guaranteed to be chemically pure. Supplied in cans from 10 pounds up.

THIS IS THE CHEAPEST AND PUREST FORM OF ENRICHING MATERIAL.

CRYSTAL CARBON LIGHT CO.,
Main Office, No. 1018 Chestnut Street, Philadelphia, Pa.

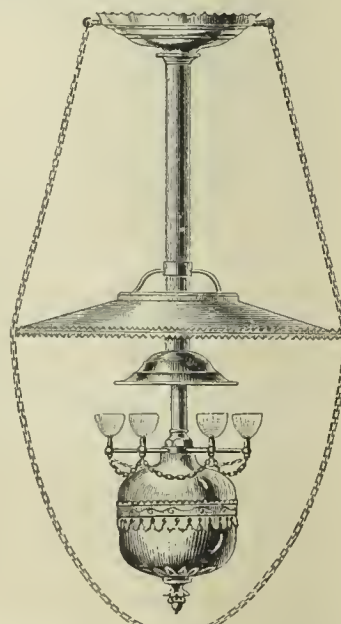

GAS

AS A SOURCE OF

LIGHT, HEAT, AND POWER.

By C. J. R. HUMPHREYS.

A Pamphlet of twenty-nine pages, treating of the use of Gas as a source of Light, Heat, and Power.

DESIGNED FOR DISTRIBUTION BY GAS COMPANIES AMONG THEIR CUSTOMERS AND OTHERS.

Price, 10 cents each, \$5 per 100, \$50 per 1,000.

Gas Companies can have their own imprint placed on cover without extra charge. All orders to be sent to

A. M. CALLENDER & CO.,

No. 42 Pine Street, N. Y. City.

CONNELLY'S AUTOMATIC GOVERNOR FOR STREET MAINS.

We invite the attention of all practical Gas Managers to the following letter and accompanying cut. The two lines show the pressure held by the Governor on Saturday and Sunday, and clearly illustrates the accuracy of the Governor in *increasing and reducing pressure in proportion to the volume of gas consumed.*

A Governor that puts the increased pressure on at "one fell swoop" and takes it off in like manner is *not* an "Automatic" Governor; and the circulation of pressure sheets showing such action by a so-called "Automatic" Governor is a rather amusing reflection on the intelligence of Gas Managers.

Strictly speaking, a "Balanced" Governor is an "Automatic" one, as it automatically varies the volume of gas sent out to *maintain a uniform pressure* at its outlet. But, as now applied, the term "Automatic Governor" is understood to mean a Governor that will *maintain pressure between any two desired extremes, in direct proportion to the volume of gas consumed.* Therefore pressure sheets showing *instantaneous changes* from maximum to minimum and *vice versa*, circulated broadcast as the record of an "Automatic (?) Governor," reveals inexcusable ignorance of the subject, amusing to many, yet liable to mislead the inexperienced novice.

We would suggest that all Gas Companies contemplating the placing of *Automatic* Governors would consult their own interests and avoid annoying experience by adopting a Governor *that has a record.*

CONNELLY & CO., LTD., 177 Broadway, N. Y.

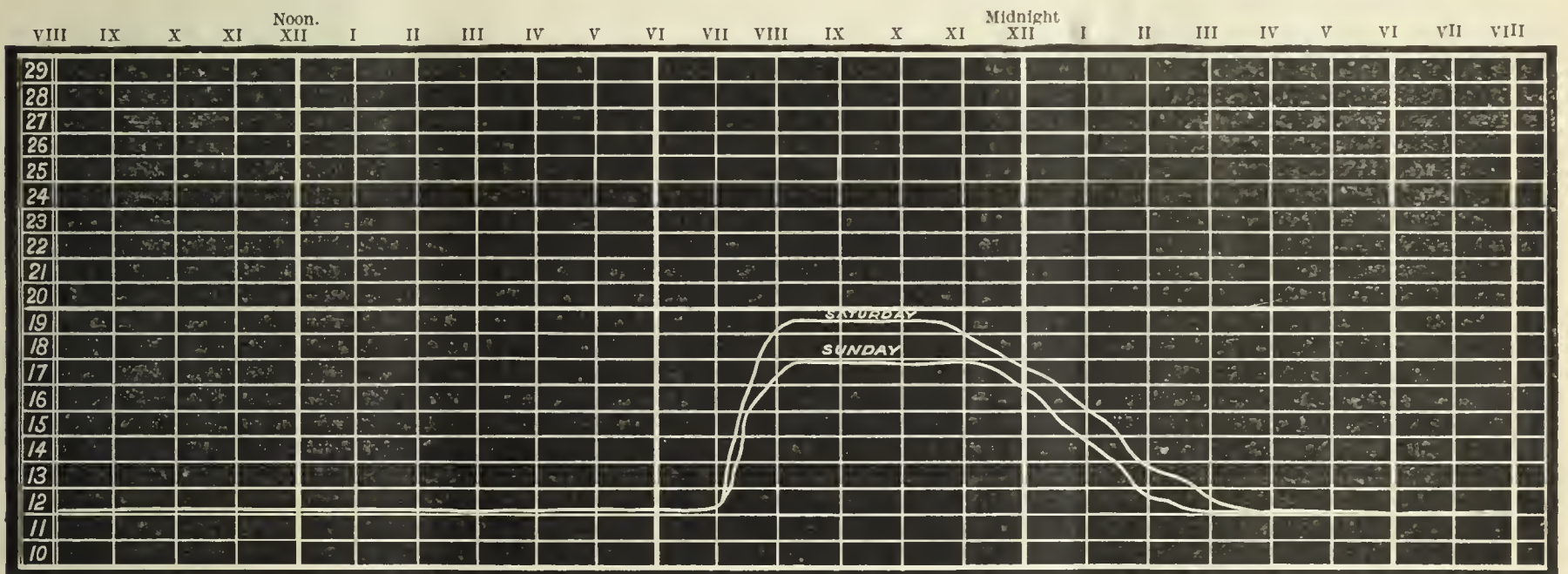

Card Showing Pressure at the Milwaukee Gas Works, Saturday, July 10, and Sunday, July 11 1886.

MILWAUKEE, Wis., August 3d, 1886.

MESSRS. CONNELLY & Co., LTD., 177 Broadway, New York:

Gentlemen—Replying to yours of 29th, I send you a little package of register sheets. When your Governor (20-inch) was set I adjusted it to give 13-tenths day pressure and 22-tenths night pressure. Saturday nights it would run up to 25-tenths. Whenever it would cloud up in the daytime it would go up at first indication of darkness to about 15-tenths. I hunted back in the sheets to find one when pressure was increased in the daytime, but it is so long since we have had a stormy day I could not find one. You can, however, see a *slight change* on sheets for June 1 and June 25. You will see, too, that lately the Governor only puts on *about 20-tenths maximum pressure.* This is because *less gas is burned than when it was adjusted.* We have no complaints of pressure, and everyone appears satisfied. In conclusion, can say the Governor has *never been touched* since it was first adjusted, and has at all times *done just the work we wished it to do.* Very truly yours, E. G. COWDERY, Engr. & Supt.

T. C. HOPPER'S
AUTOMATIC DIFFERENTIAL GAS GOVERNOR

Is now in Practical Operation, doing Perfect Automatic Service with Great Precision.

This Governor will do all and more than any other Governor on the Market.

BE SURE TO THOROUGHLY INVESTIGATE THE SUPERIOR MERITS OF THIS GOVERNOR BEFORE PURCHASING.

For Simplicity and Reliable Work it has no Equal. Correspondence Solicited.
T. C. HOPPER & CO., - - - - - Manufactory, 2227 Wood Street, Phila, Pa.

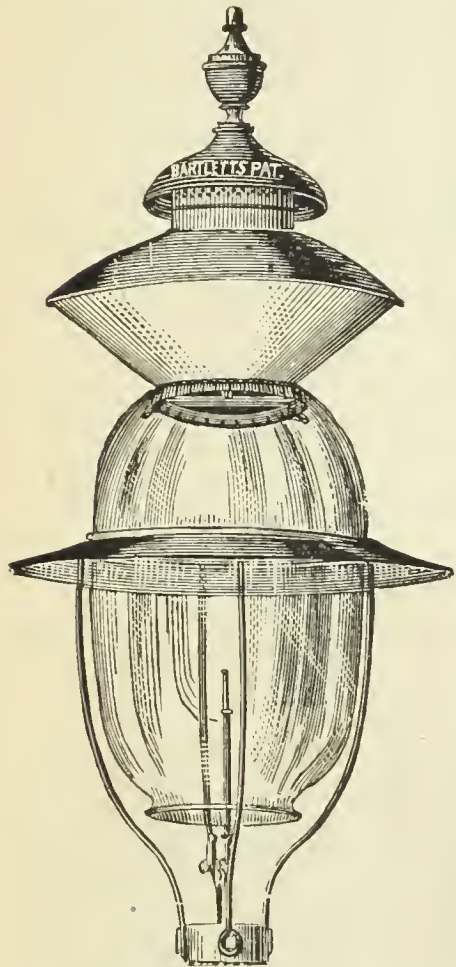

G. S. COOK, Pres. THOS. DAVENPORT (late Davenport Bros.), Sec. & Treas

BARTLETT
Street Lamp Mfg. Co.

MANUFACTURERS OF

Bartlett's Patent

GLOBE LAMPS,

FOR

Streets, Parks, Railroad Stations, Public Buildings, Etc.

LAMP POSTS A SPECIALTY.

Office and Salesroom

No. 35 Howard Street, N. Y. City.

Gas Companies and others intending to erect lamps and posts will do well to communicate with us.

F. M. ROOTS.

S. C. ROOTS

D. T. ROOTS.

P. H. & F. M. ROOTS,
 PATENTEES AND MANUFACTURERS OF

GAS VALVES, BYPASS VALVES, EXHAUSTER-GOVERNORS

PIPE FITTINGS, & ALL FIXTURES FOR EXHAUSTER ROOMS.

IMPROVED GAS EXHAUSTER,

WITH ENGINE ON SAME BED PLATE, OR WITHOUT.

BYE-PASSES, GAS VALVES, GOVERNORS, ELBOWS, PIPE-FITTINGS, Etc., FURNISHED TO ORDER,

P. H. & F. M. ROOTS, Patentees & Manufacturers, **CONNERSVILLE, IND.**

S. S. TOWNSEND, General Agent, 22 Cortland St.

COOKE & CO., Selling Agents, 22 Cortland St., N. Y.

❖ SEND FOR ILLUSTRATED CATALOGUE AND PRICE LIST. ❖

CONNELLY & CO., LTD.

MANUFACTURERS OF

Steam-Jet Exhausters

Requires one-half the floor space and one-third less steam than any other Exhauster in the market. More cheaply and easily connected, as outside by-pass valves are dispensed with. It is the only Exhauster manufactured having Compensator and Governor combined; the Compensator with all other Exhausters being a separate and distinct machine. It is simple in construction, easily adjusted, not liable to get out of order, and can be operated by ordinary workmen. Over 1,000 now in use.

No. 177 Broadway, New York.

LUDLOW VALVE MFG. CO.

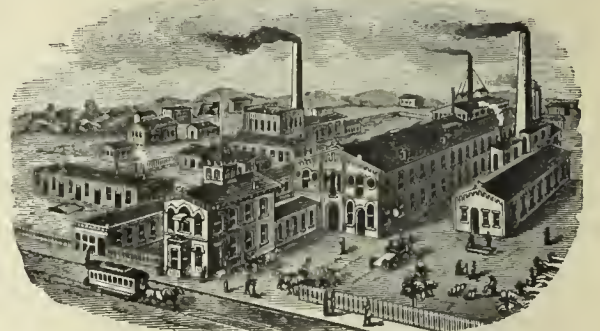

OFFICE AND WORKS,

938 to 954 River Street and 67 to 83 Vail Av. TROY, N. Y.

Hydraulic Main Dip Regulators, also Check Valves, Foot Valves, Yard wash and Fire Hydrants. Send for Circulars.

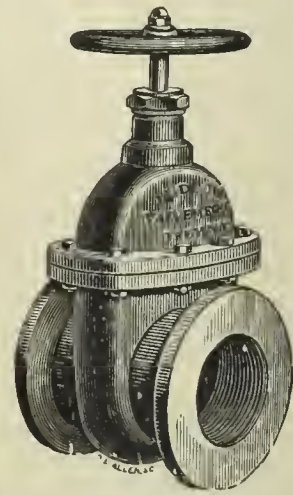

Valves.—Double and Single Gate, 1/2 in. to 48 in., outside and inside Screws. Indicator, etc., for Gas, Water, Steam, and Oil. Send for Circulars.

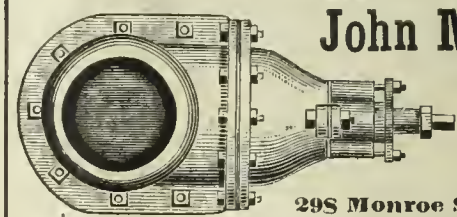

John McLean

Man'furer of

GAS VALVES.

298 Monroe Street, N. Y.

GAS vs. ELECTRIC LIGHT.

We would invite attention to the able and exhaustive argument of General A. Hicklenooper, President of the Cincinnati Gas Light and Coke Company, contained in a handsome pamphlet of 96 pages, entitled

"EDISON'S INCANDESCENT ELECTRIC LIGHTS FOR STREET ILLUMINATION. REPORT OF AN ARGUMENT DELIVERED BY A. HICKENLOOPER BEFORE THE COMMITTEE ON LIGHT, MUNICIPAL COUNCIL, CITY OF CINCINNATI, JULY 22, 1886."

This is a subject of special interest to all Gas Light Companies.

Prices.

25 copies..... \$7.50 100 copies..... \$22.50
 50 copies..... 12.50 250 copies..... 50.00

A sample copy will be sent by mail on receipt of 50 cts.
A. M. CALLENDER, & CO., 42 PINE ST., N. Y. CITY.

C. W. HUNT CO.,

No. 111 Broadway, N. Y. City.

MANUFACTURERS OF

Coal Handling Machinery,

AUTOMATIC RAILWAY, HOISTING ELEVATOR, CABLE RAILWAY, STEAM SHOVEL, HOISTING ENGINES, COAL TUBS, COAL & COKE CARS.

Plans and Specifications made for the

Erection of Coal Storage Buildings
 Send for a Descriptive Pamphlet.

GAS STOVES.

GAS STOVES.

GAS STOVES.

THE AMERICAN METER CO.,

MANUFACTORIES,

508 to 514 West Twenty-second St., N. Y.

Arch and Twenty-second St., Phila.

Nos. 244 & 246 North Wells Street, Chicago, Ill.

AGENCIES,

No. 177 Elm Street, Cincinnati, Ohio.

Nos. 122 & 124 Sutter Street, San Francisco Cal.

No. 810 North Second Street, St. Louis, Mo.

NEW

INCANDESCENT

Gas Fires

AND

OPEN

Fire Place

Heaters.

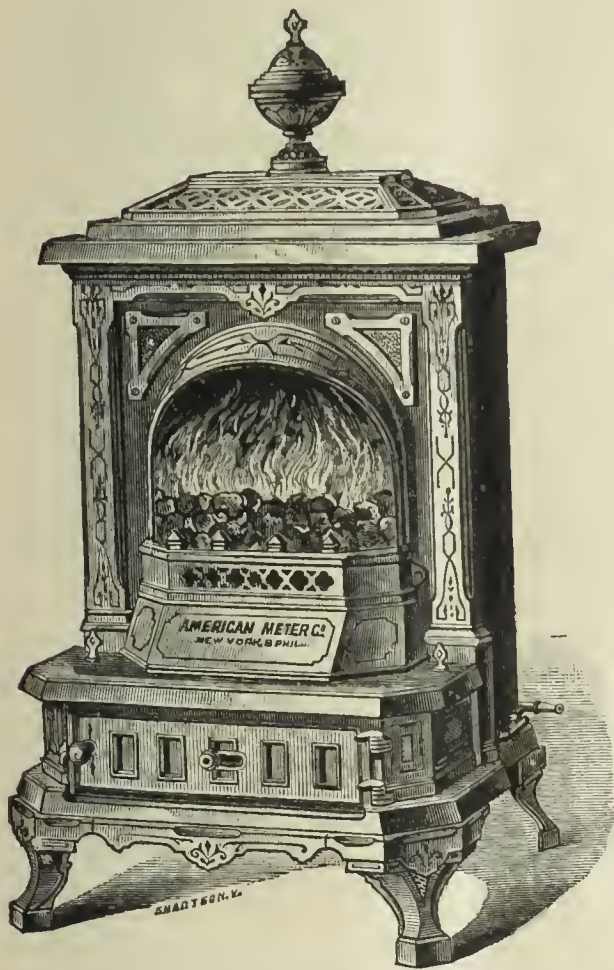

Open Fire Place Heater No. 19.
Fitted with the new Incandescent Gas Fire.

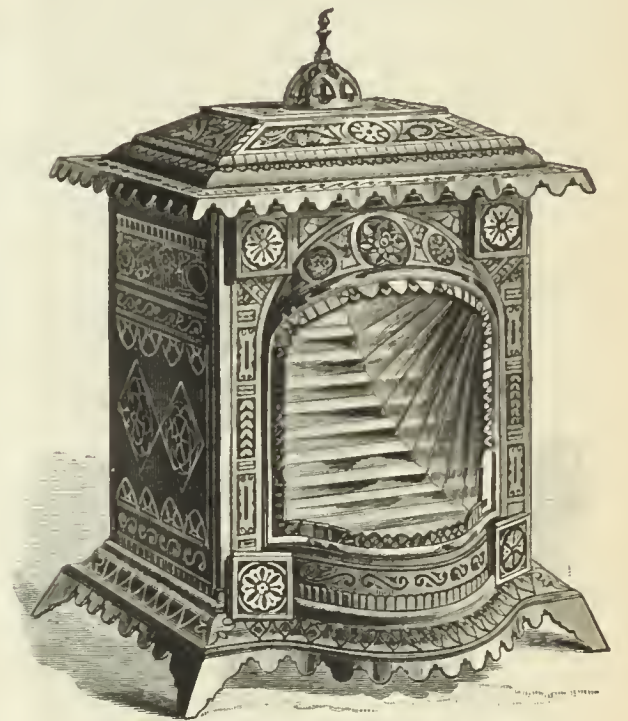

Open Fire Place Heater No. 17C.
Fitted with Illuminating Burners and Copper Reflectors.

We call attention to Special Apparatus Heated by Gas for Manufacturing Purposes.

GAS FURNACES FOR TINMEN'S USE; FURNACES FOR MELTING SOLDER AND TYPE METAL; APPARATUS FOR BENDING CARRIAGE PANELS, NOW IN SUCCESSFUL OPERATION IN CARRIAGE MANUFACTORIES; WATER HEATERS FOR KITCHEN BOILERS, BATHS, ETC., AND FOR ATTACHING TO HEATING COILS AND PIPES FOR CONSERVATORIES.

THE COMPANY MANUFACTURE

GAS STOVES FOR COOKING AND HEATING PURPOSES

In all Sizes, for Domestic, Restaurant, and Hotel Use.

These Stoves may be seen in operation at our Retail Store, No. 223 Sixth Avenue, N. Y. Call and examine.

SEND FOR CATALOGUE OF TWENTY DIFFERENT STYLES OF HEATING STOVES.

RETORTS AND FIRE BRICK.

J. H. GAUTIER & CO.,
CORNER OF
GREENE AND ESSEX STREETS,
JERSEY CITY, N. J.

MANUFACTURERS OF

**Clay Gas Retorts,
Gas House Tiles,
Fire Bricks, Etc. Etc.**

Ground Clay, Fire Brick and
Fire Sand in Barrels,

J. H. GAUTIER.
C. E. GREGORY.

T. B. GAUTIER.
C. E. GAUTIER.

BROOKLYN

Clay Retort & Fire Brick Works,
(EDWARD D. WHITE & CO.)

Manufacturers of Clay Retorts, Fire Brick,
Gas House and other Tile.

VAN DYKE, ELIZABETH, RICHARDS & PARTITION STS.
Office, 88 Van Dyke St., Brooklyn, N. Y.

RETORTS AND FIRE BRICK.

LACLEDE FIRE BRICK MFG. CO.,

MANUFACTURERS OF

Fire Brick, Gas Retorts,

AND

ST. LOUIS STANDARD SEWER PIPE.

Blast Furnace and Cupola Linings, every description of Fire
Clay Material, Fire Clay Flue Linings, Chimney Tops
Dry Milled and Crude Fire Clays, etc.

OFFICE AND DEPOT

901, 903, and 905 Pine Street,
ST. LOUIS, MO.

ESTABLISHED IN 1845.

B. KREISCHER & SONS,

OFFICE FOOT OF HOUSTON ST., E.R., N. Y.

Gas Retorts,

TILES, FIRE BRICK.

AND EVERYTHING IN THE FIRE CLAY LINE.

RETORTS AND FIRE BRICK.

MANHATTAN

FIRE BRICK & ENAMELLED CLAY

RETORT WORKS.

ADAM WEBER.

**CLAY GAS RETORTS
AND RETORT SETTINGS
FIRE BRICKS, TILES, ETC.,**

Office and Works, 15th Street and Avenue C., N. Y.



Works,
LOCKPORT STATION, PA.

—ESTABLISHED 1864.—

JAMES GARDNER, JR.,

Successor to WILLIAM GARDNER & SON.

Office, Rooms 19 & 20, Lewis Block,
PITTSBURGH, PA. P. O. Box 373.

Fire Clay Goods for Gas Works.

CHAS. H. SPRAGUE & SON, No. 70 KILBY STREET, BOSTON, MASS., Agents for the New England States.

OFFICE, 418 to 422 East 23d St., New York.

ESTABLISHED 1856.

WORKS, PERTH AMBOY, NEW JERSEY.

HENRY MAURER & SON,

Excelsior Fire Brick & Clay Retort Works

CLAY GAS RETORTS, BENCH SETTINGS, FIRE BRICK, TILES, ETC.

CHICAGO

Retort & Fire Brick Works,

OFFICE AND FACTORY,
Clark, Forty-Fifth, and La Salle Streets,
CHICAGO, ILL.

GEORGE C. HICKS, PRES. PAUL P. USTIN, SEC. & TREAS.

STANDARD

Clay Retorts and Settings.

BLOCKS & TILES

Of every Shape and Size to Order.

Standard Fire Bricks.

NEWBIGGING'S

Gas Manager's Handbook.

Price, \$4.80.

EVERY GAS MAN SHOULD HAVE ONE.

Orders may be sent to this Office.

OAKHILL

GAS RETORT & FIRE BRICK

Works.

Proprietors,

PARKER-RUSSELL MINING & MFG. CO.

City Office, 711 Pine Street,

ST. LOUIS, MO.

Our immense establishment is now employed almost entirely in
the manufacture of

MATERIALS FOR GAS COMPANIES.

We have studied and perfected three important points. Our retorts are made to stand changes of temperature, the strongest heats of the furnace, and the abrasion of feeding and emptying. Our customers are in almost every State of the Union, to all of whom we refer.

THOS. SMITH, Prest. AUGUST LAMBLA, Vice-Prest. & Sup

BALTIMORE

RETORT & FIRE BRICK CO.

MANUFACTORY AT

LOCUST POINT, BALTIMORE, MD.

Connection with the City by Telephone.

Clay Retorts, Blocks & Tiles,

FIRE BRICK, FIRE CLAY,

AND FIRE CEMENT.

Red and Buff Ornamental Tiles and Chimney
Tops. Drain and Sewer Pipe (from
2 to 30 inches). Baker Oven Tiles
12 x 12 x 2 and 10 x 10 x 2.

WALDO BROS., 88 WATER ST., BOSTON, MASS

Sole Agents the New England States

RETORTS AND FIRE BRICK.

REGENERATIVE FURNACES.

STEAM PUMPS.

EVENS & HOWARD,

916 Market St., St. Louis. Mo.

Works, Howard Station, Mo. Pacific R.R.

Fire Brick, Gas Retorts

AND

RETORT SETTINGS.

Sewer Pipe, 3 to 24 in. diameter.

Glass Pot Clay, Ground Fire Clay, in barrels and in bulk. All kinds of Fire Clay Goods.

Cincinnati Gas Retort & Fire Brick Works.

—ESTABLISHED 1872.—

CHAS. TAYLOR,

MANUFACTURER OF

Gas Retorts, Fire Brick, and Tile.

Blast Furnace Linings, Cupola Blocks, Boiler Tiles, Grate Settings, and Stove Linings. Fire Cement, Fire Clay, Fire Sand, and all other Fire Clay Goods.

Branch Works, New Cumberland, W. Va.

GENERAL OFFICE AND WORKS,

Burns St., Cincinnati, Ohio.

Stettiner

Chamotte Fabrik Actien Gesellschaft,

Formerly DIDIER,

(Patentees of the Dr. Schilling & Dr. Bunte Regenerative Furnace)

STETTIN, GERMANY.

The attention of all Gas Engineers is called to our Fire-Proof Material, viz.:

CLAY GAS RETORTS

(ENAMELED AND UNENAMELED),

Blocks, Tiles

AND

EXTRA FIRE BRICK,

Pronounced by the highest authorities as superior to and excelling any other similar manufacture. The component of aluminum contained in our material (up to 45 per cent.) is larger than in any other material heretofore sold in the United States; whilst the uniformity of the goods is assured by the most scrupulous analysis of the clay used.

For any further information and prices please apply to

EMIL LENZ,

2 & 4 Stone St., Room 19, N.Y. City.

PATENTS.

FRANKLIN H. HOUGH,

Solicitor of American & Foreign Patents

925 F. ST., WASHINGTON, D. C.

(NEAR U. S. PATENT OFFICE.)

Personal attention given to the preparation and prosecution of applications for Letters Patent. All business before the U.S. Patent Office attended to for moderate fees. **No Agency in the United States possesses superior facilities for obtaining Patents,** or for ascertaining the patentability of inventions. Copies of patents furnished for 25 cents each. Correspondence solicited.

ADAM WEBER'S

New and Improved Regenerative Furnace.

ESPECIALLY ADAPTED FOR USE IN SMALL GAS WORKS.

A Saving of at Least Forty per Cent. over Old Methods.

Cheapness of construction and absence of elaboration are the chief characteristics of this Furnace. It is also applicable in cases where it is not convenient to excavate deeply below the line of the retort house.

Correspondence respectfully solicited. Descriptive Circulars on application.

Manhattan Fire Brick & Enameled Clay Retort Works.

OFFICE, 633 EAST FIFTEENTH STREET, N. Y. CITY.

MUNICH REGENERATIVE FURNACE

System Drs. Schilling and Bunte.

Greatest Durability! Minimum of Attention!

COMPLETE DISTILLATION IN 3½ HOURS.

Ten to Thirteen Pounds of Coke to Hundredweight of Coal.

NO CLINKER. NO CARBONIC OXIDE IN THE REGENERATIVE FLUES.

Almost Automatic in Action.

The Most Successful Regenerative Furnace in Use.

BARTLETT, HAYWARD & CO.

Agents for the United States.

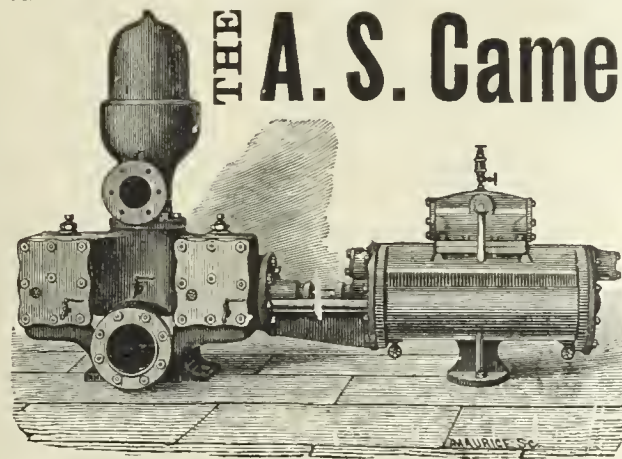

THE A. S. Cameron Steam Pump,

THE STANDARD OF EXCELLENCE.

Upward of 30,000 in Use.

BEST GAS WORKS PUMP

Ever Introduced.

Adapted to Every Possible Duty.

A. S. Cameron Steam Pump Works.

Foot East 23d St., N. Y.

Parson's Steam Blower,

FOR IMPROVING BAD DRAUGHT IN BOILERS, AND FOR BURNING BREEZE OR OTHER WASTE MATERIAL.

PARSON'S TAR BURNER,

FOR UTILIZING COAL TAR AS FUEL.

PARSON'S AIR JET TUBE CLEANER,

FOR CLEANING BOILER TUBES.

These devices are all first-class. They will be sent to any responsible party for trial. No sale unless satisfactory. Manufactured by the WATERTOWN STEAM BLOWER COMPANY.

H. E. PARSON, Supt., 42 PINE ST., N. Y.

GAS AND WATER PIPES.

GAS AND WATER PIPES.

ENGINEERS.

SAM'L R. SHIPLEY, Pres.
HENRY B. CHEW, Treas.

JAS. P. MICHELLON, Sec.
WM. SEXTON, Supt.

P. D. WANNER, Chairman. A. H. MELLERT, Sec. & Treas.

GLOUCESTER IRON WORKS,
GLOUCESTER CITY, N. J.



Cast Iron Gas & Water Pipes, Stop Valves, Fire Hydrants, Gasholders. &c.

Office No. 6 North Seventh Street, Philadelphia.

ESTABLISHED 1856.

WARREN FOUNDRY AND MACHINE CO.,

WORKS AT PHILLIPSBURGH, N. J.
NEW YORK OFFICE, 162 BROADWAY.

Cast Iron Water and Gas Pipe

FROM TWO TO FORTY-EIGHT INCHES DIAMETER.
ALSO ALL SIZES OF

FLANGE PIPE for Sugar House and Mine Work.
Branches, Bends, Retorts, Etc., Etc.

436-1

MATHEW ADDY, President.

W. L. DAVIS, Selling Agent.

GEO. P. WILSHIRE, Sec. & Treas.

Cincinnati and Newport Iron and Pipe Company,

NEWPORT, KY.

Lamp Posts

AND

BENCH CASTINGS

A Specialty.

Large & Heavy Castings for General Work.
Manufacture Pipe from 2 to 48 inches. All work guaranteed first quality.

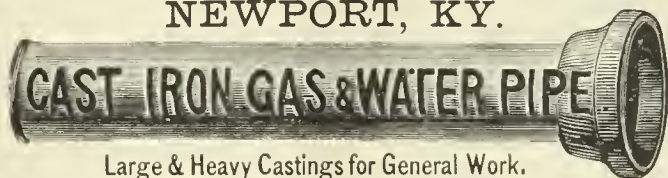

Branch

AND

SPECIAL CASTINGS

FOR GAS & WATER CO'S.

Pancoast & Rogers.

WROUGHT IRON PIPE,

VALVES AND GATES,

Cast Iron Gas & Water Pipe.

28 Platt and 15 Gold St., New York.

The Management of Small Gas Works.

By C. J. R. HUMPHREYS. Price, \$1.

A. M. CALLENDER & CO., 42 Pine St., N. Y.

MELLERT FOUNDRY & MACHINE CO., Ltd.
Reading, Pa.



Specials—Flange Pipe, Valves and Hydrants,
Lamp Posts, Retorts, etc.

General Foundry and Machine Work.

JOHN FOX, Selling Agent. 160 Broadway, N. Y.

THE OHIO PIPE COMPANY,

MANUFACTURERS OF

Cast Iron Gas & Water Pipe,

BRANCH AND SPECIAL CASTINGS.

Gas-House Bench Castings, Hydraulics, Lamp Posts, Flange Pipe
and Specials, Architectural Castings, Building Columns,
Joists, Cellar Grates, Sash Weights, etc.

GENERAL FOUNDERS AND MACHINISTS.

Columbus, Ohio.

M. J. DRUMMOND,



SPECIAL CASTINGS AND LAMP POSTS.

95 Liberty St., - New York.

JOS. R. THOMAS, C.E.,

May be Consulted on all Mat-
ters Relating to Gas Works
and Gas Manufacture.

ADDRESS THIS OFFICE.

WM. FARMER, ENGINEER,

32 Park Place, Room 36, New York.

THE CHEMIST'S ASSISTANT; OR, KINDERGAR-
TEN SYSTEM OF CHEMISTRY.

A system by which the elements and their valences are repre-
sented by illustrations and solid bodies.

BOX AND PAMPHLET COMPLETE, \$2.50.

WM. HENRY WHITE,

CONSULTING AND CONSTRUCTING

Gas Engineer & Contractor

Estimates, Plans, and Specifications furnished for new wo
extensions of existing works.

No. 32 Pine Street, New York City.

Correspondence solicited.

WM. GARDNER,

Gas Engineer,

Lewis Block, Room 20, Pittsburgh, Pa.

Those who intend to make alterations in existing gas plants, or
who contemplate the erection of new works, will find it to their
interest to open correspondence with the above. Plans made
and estimates furnished.

GAS LAMPS.

SCRUBBERS AND CONDENSERS.

The Siemens and Lungren REGENERATIVE GAS LAMPS.

A System of Burning Gas whereby its Illuminating Power is Increased from 300 to 400 per ct. without the Expense, Trouble and Annoyance resulting from the use of Hydrocarbon Enriching Material.

The Siemens-Lungren Company received the only Silver Medal or Highest Award for Gas Burners at the "Novelties" Exhibition of the Franklin Institute, held at Phila., Oct., '85.

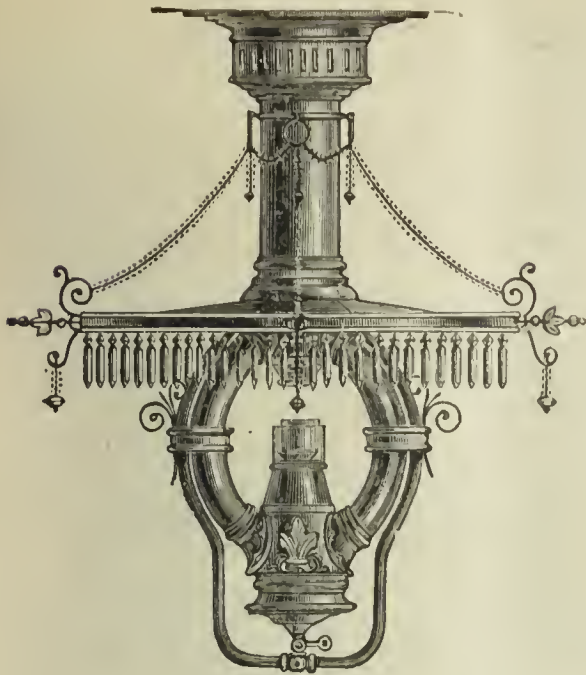

SIEMENS LAMP.

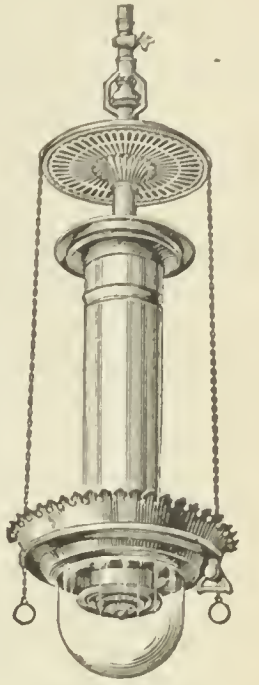

LUNGREN LAMP

THIRTEEN CANDLE POWER PER CUBIC FOOT OF GAS!

This result is obtained

SIMPLY BY THE SCIENTIFIC APPLICATION OF THE REGENERATIVE PRINCIPLE.

Consequently this largely increased illumination is always maintained without further cost and frequent attention.

THE SIEMENS-LUNCREN COMPANY,

N. E. Cor. 21st. St. and Washington Av., Phila., Pa.

THE PATENT "STANDARD" WASHER-SCRUBBER

Has been adopted by gas companies in all parts of the world. Between 300 and 400 companies, with the enormous daily output of over 300,000,000 cubic feet. are now using it. "Standard" Washer-Scrubbers have been erected for the following gas light companies since Jan. 1, 1886:

WALLASEY, ENGLAND.....	750,000 cubic feet.	RICHMOND, SURREY, ENGLAND.....	1,500,000 cubic feet.
NEWARK, ENGLAND.....	350,000 "	BRIDGEPORT, U. S.....	500,000 "
BUFFALO, U. S. (MUTUAL).....	500,000 "	TORONTO, CANADA.....	1,000,000 "
BERLIN, GERMANY.....	1,250,000 "	HARTFORD, U. S.....	1,000,000 "
SO. BRISBANE, AUSTRALIA.....	300,000 "	DETROIT, U. S.....	750,000 "
LEEDS, ENGLAND.....	2,600,000 "	SINGAPORE, CEYLON.....	300,000 "
FURTH, GERMANY.....	400,000 "	BRUNSWICK, GERMANY.....	300,000 "
FREIBURG, GERMANY.....	200,000 "	LILLE, FRANCE.....	750,000 "
NINE ELMS, LONDON.....	3,000,000 "	CADIZ, SPAIN.....	300,000 "
MELBOURNE, AUSTRALIA (2).....	3,000,000 "	READING, ENGLAND.....	2,000,000 "
GLUCKAUF COKE WORKS, GERMANY.	200,000 "	LINCOLN, U. S.....	250,000 "
BOURNEMOUTH, ENGLAND.....	1,000,000 "	ST. LOUIS, U. S. (LACLEDE).....	1,000,000 "
		BROOKLYN, U. S.....	2,000,000 "

That this apparatus is really the *standard* is indicated by the following names of important houses who represent this invention in the different countries of the world:

FRANCE & BELGIUM, Mons. J. A. Berly, 31 Rue Boinod, Paris. HOLLAND & DUTCH COLONIES, Mess. W. Hoven & Zoon, Rotterdam.

GERMANY and AUSTRO-HUNGARY, Berlin-Anhaltische-Actiengesellschaft, Berlin, Moabit, and Dessau.

RUSSIA, Mr. F. Bley, Galernaya, 44, St. Petersburg. SPAIN, Mess. Nicolas, Chamon, Foiret & Cie., 29 Rue Claude-Vellefaux, Paris.

ITALY & MALTA, Sig. E. Canziani, 26 & 28 Portici, Vittorio Emmanuele, Genoa. Sig. Fratelli Scheuer, Via Chiaja, 124, Naples.

NEW SOUTH WALES, Messrs. W. Coward & Sons, 143 Queen Victoria St., London.

NEW ZEALAND and VICTORIA, Messrs. G. D. Jennings & Co., 28 Gracechurch St., London.

Companies in the U. S. adopting this apparatus can now be assured of a market for the Ammoniacal Liquor at a remunerative price. Correspondence for purchase of "Standards" and Ammoniacal Liquor is solicited by the

SOLE AGENT AND MANUFACTURER FOR THE WESTERN HEMISPHERE,

GEO. SHEPARD PAGE, 69 WALL STREET, NEW YORK.

GAS WORKS APPARATUS AND CONSTRUCTION.

GAS WORKS APPARATUS AND CONSTRUCTION.

WORKS: { MILLVILLE, N. J.
FLORENCE, "
CAMDEN, "

R. D. WOOD & CO.,

OFFICES: { 400 CHESTNUT ST.,
PHILADELPHIA.

CAST-IRON PIPE 1½ to 72 Inches in Diameter.

Water Machinery and Gas Apparatus.

HEAVY CASTINGS.

HOLDERS,

PURIFIERS,

FLOORS AND ROOFS,

LAMP POSTS,

CONDENSERS,

FLANGED PIPE,

VALVES,

BENCH WORK,

FIRE HYDRANTS,

METER CASES.

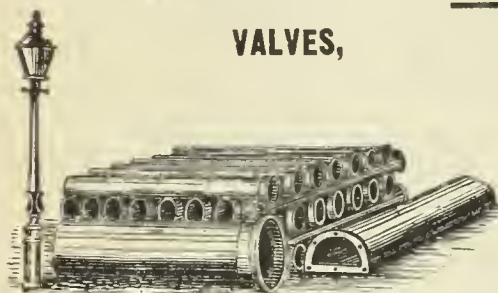

Estimates and Specifications for
NEW WORKS or **EXTENSIONS**
or **ALTERATIONS** of **OLD ONES.**

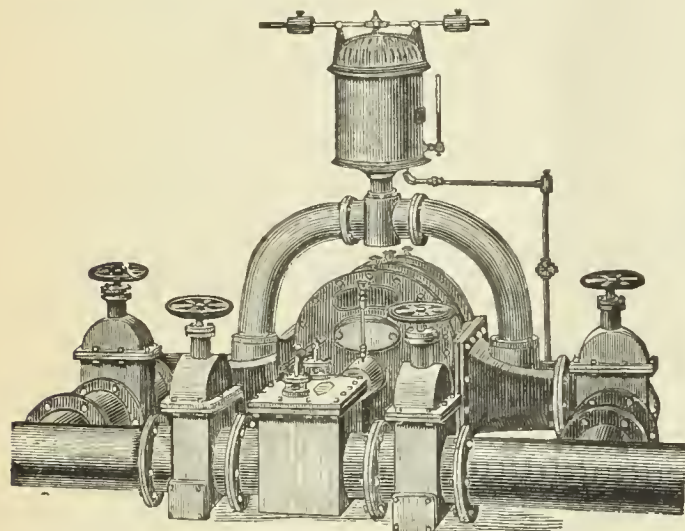

SMITH & SAYRE MFG. COMPANY,

G. G. PORTER, Prest.

245 Broadway, N. Y.

CHAS. W. ISBELL, Sec'y.

Machinery & Apparatus for Gas Works

Drawings, Plans, and Estimates Furnished for the Improvement, Extension, or Alteration of Gas Works, or for the Construction of New Works.

Mackenzie's Patent Rotary and Steam Jet Gas Exhausters, Governors, Compensators, Condensers, Washers, Scrubbers. Isbell's Patent Automatic Street Pressure Governor, Gas and Water Valves, Hydraulic Main Dip Regulator, Bench Castings, etc. Purifying Boxes and "Standard" Scrubbers. Isbell's Patent Self-Sealing Retort Doors.

SOUTHWARK FOUNDRY AND MACHINE COMPANY,

Successors to MERRICK & SONS,

GAS APPARATUS,

Holder, Purifiers, Washers, Etc., Etc. Boiler and Tank Work. Steam Engines. Hydraulic Machinery. Bessemer Plants, Etc.

Washington Ave. and Fifth Street, Philadelphia, Pa.

MORRIS, TASKER & CO.,

Limited,

Builders of Gas Works,

PHILADELPHIA PA.

GOODWIN'S DIRECTORY

OF THE

GAS LIGHT COMPANIES OF THE UNITED STATES & CANADA

Price, \$10.00.

Orders may be sent to

A. M. CALLENDER & CO., No. 42 Pine Street, N. Y. City.

GAS WORKS APPARATUS AND CONSTRUCTION.

GAS WORKS APPARATUS AND CONSTRUCTION.

JAMES R. FLOYD,

(SUCCESSOR TO HERRING & FLOYD)

Oregon Iron Works,

531 to 543 West 20th St., N. Y.

Practical Builders of Gas Works,

MANUFACTURERS OF

ALL KINDS OF CASTINGS
AND

APPARATUS FOR GAS-WORKS.

BENCH CASTINGS

from benches of one to six Retorts each.

**WASHERS: MULTITUBULAR AND
AIR CONDENSERS; CONDENSERS;
SCRUBBERS**

wet and dry), and

EXHAUSTERS

for relieving Retorts from pressure.

BENDS and BRANCHES

all sizes and description.

FLOYD'S PATENT

MALLEABLE RETORT LID.

PATENT

SELF-SEALING RETORT LIDS.

FARMER'S

PATENT BYE-PASS DIP-PIPE.

SABBATON'S PATENT

FURNACE DOOR AND FRAME.

BUTLER'S

COKE SCREENING SHOVELS.

GAS GOVERNORS,

and everything connected with well regulated Gas Works at low price, and in complete order.

SELLER'S CEMENT

for stopping leaks in Retorts.

N. B.—**STOP VALVES** from three to thirty inches—at very low prices.

Plans, Specifications, and Estimates furnished.

KERR MURRAY MFG. CO.,

MANUFACTURERS OF

Single Lift and Telescopic

GASHOLDERS.

Built, 1884:

Altoona, Pa.....	Capacity, 160,000 cubic feet.
Pittsburg, Pa.....	250,000 "
".....	220,000 "
Bellaire, Oblo.....	50,000 "
Youngstown, Ohio.....	60,000 "
Canton, ".....	60,000 "
Akron, ".....	80,000 "
Xenia, ".....	10,000 "
Adrian, Mich.....	65,000 "
Ypsilanti, Mich.....	25,000 "
Muskegon, ".....	70,000 "
South Bend, Ind.....	70,000 "
Anderson, ".....	20,000 "
Plainfield, ".....	10,000 "
Springfield, Illinois.....	100,000 "
Evanston, ".....	50,000 "
Freeport, ".....	35,000 "
Elgin, ".....	60,000 "
Sheboygan Wis.....	20,000 "
Key West Fla.....	10,000 "

Plans and estimates furnished for the erection of new and the rebuilding of old works. Address

Kerr Murray Mfg. Co.,
FORT WAYNE, IND.

CONTINENTAL WORKS.



GASHOLDERS OF ANY MAGNITUDE.

T. F. ROWLAND, Proprietor,

GREENPOINT, BROOKLYN, N. Y.

ENGINEER AND MANUFACTURER OF

GAS-HOLDERS,

CONDENSERS, SCRUBBERS, VALVES,

PURIFIERS, RETORTS, and HY-

DRAULIC MAINS,

and all other articles connected with the Manufacture and Distribution of Gas. Plans and Specifications prepared and Proposals given for the necessary Plant for Lighting Cities, Towns, Mansions, and Manufactories.

H. RANSHAW, Pres. & Mangr. WM. STACEY, Vice-Prest. T. H. BIRCH, Asst. Mangr. R. J. TARVIN, Sec. & Treas.

STACEY MFG. CO.,

MANUFACTURERS OF

Single and Telescopic Gasholders,

IRON ROOFS, BRIDGES, LAMP POSTS,

Water and Oil Tanks, Coal Elevator Cars,

COKE CRUSHERS, BENCH CASTINGS,

And all kinds of Wrought and Cast Iron Work used in the erection of Coal and Oil Gas Works. Rolling Mill Machinery and Heavy Castings a Specialty.

Foundry:

33, 35, 37 & 39 Mill Street.

Wrought Iron Works:

16, 18, 20, 22, 24 & 26 Ramsey Street.

Cincinnati, Ohio.

BARTLETT, HAYWARD & CO.,

Office, German & Calvert.

BALTIMORE, MD.

Works, Pratt & Scott.

PURIFIERS.

Roofs.
Bench Castings.



SCRUBBERS.

CONDENSERS.

GASHOLDERS.

CONSTRUCTING ENGINEERS AND BUILDERS OF GAS WORKS.

1842. DEILY & FOWLER, 1886.

Laurel Iron Works.

Address, No. 39 Laurel Street, Philadelphia, Pa.

MANUFACTURERS OF

GASHOLDERS,

Single or Telescopic, with Cast or Wrought Iron Guide Frames.

HOLDERS BUILT SINCE 1881:

Scranton, Pa. (2d)	Hollidaysburg, Pa.	Jackson, Mich.	Montgomery, Ala.	New Castle, Pa.
West Point, N. Y.	Galveston, Texas (2d.)	Kalamazoo, Mich. (3d.)	Newport, R. I.	Long Island City, N. Y.
Fitchburg, Mass.	Marlboro, Mass.	Glen Island, N. Y.	Portland, Oregon.	Macon, Ga.
New London, Conn.	Denver, Col.	Warren, Ohio.	Allegheny, Pa. (2d.)	York, Pa.
Derby, Conn.	Chicago, Ill. (West Side).	Bath, N. Y.	Atlanta, Ga. (2d.)	Chester, Pa.
Bridgeport, Conn.	Pittsburgh, Pa. (S. Side).	Lynn, Mass.	N.Y. City (Central Gas Co)	Hazleton, Pa. 2d.
Allegheny, Pa. (1st.)	Pawtucket, R. I.	New Bedford, Mass.	Lynchburg, Va. (2d.)	Novelties Exhib., Phila
St. Hyacinth, Can.	Brookline, Mass.	Waterbury, Conn.	Saylesville, R. I.	Staten Island, N. Y.
Norwalk, O.	Sherbrooke, Can.	Deseronto, Can.	Rondout, N. Y.	Saugerties, N. Y.
Brattleboro, V	Burlington, N. J. (2d.)	Hoosic Falls, N. Y. (2d.)	Atlantic City, N. J.	Clinton, Mass. (Lan. M)
Waltham, Mass. (2d.)	Bridgeton, N. J.	Bethlenem, Pa.	Augusta, Ga.	Chattanooga, Tenn.
West Chester, Pa.	Bay City, Mich.	Atlanta, Ga. (1st.)	Waltham, Mass. (2);	Galveston, Texas. (3d.)
Baltimore, Md.	Er'e, Pa.	Savannah, Ga.	Mahanoy City, Pa.	Omaha, Neb.

GAS COALS.

GAS ENRICHERS.

EXHAUSTERS.

JAMES D. PERKINS.

PERKINS & CO.,

F. SEAVERNS.

General Sales Agents for

The Youghioghenny River Coal Company's**OCEAN MINE YOUGHIOGHENY GAS COAL.**

The Coal from the Ocean Mine (recently operated by Messrs. W. L. Scott & Co., of Erie, Pa.,) is now used by all the leading Gas Companies in the United States from Maine to Texas, and is recognized as *the only reliable Youghioghenny Gas Coal.* (See Map on p. 87 of this Journal, Feb. 16, 1885.)

P. O. Box 3695,
New York.**PERKINS & CO., 228 and 229 N. Y. Produce Exchange.****BEAVER STREET
ENTRANCE.****BRECKENRIDGE CANNEL,
OF KENTUCKY.**

This colliery was re-opened in June of the present year, and the Cannel is now being delivered to thirty of the leading Gas Companies in this country. As an enricher ONE TON of this Cannel will do the work of TWO TONS of any other available Cannel. It can be delivered in parcels of one car load or more to any point in the United States or Canada. (See AMERICAN GAS LIGHT JOURNAL, June 16, '86, pp. 346-7.)

P. O. Box 3695,
New York.**PERKINS & CO., 228 and 229 N. Y. Produce Exchange****BEAVER STREET
ENTRANCE.****JAMES & WILLIAM WOOD,
Gas and Cannel Coal Contractors,**

No. 40 St. Enoch Sq., Glasgow. No. 2 Talbot Court, London.

Proprietors of the **BATHVILLE COLLIERIES** (which produce the celebrated **BOGHEAD CANNEL**), Shields, Shieldmuir, Drumpeller, and other Collieries. This Firm offer

STANDARD CANNELS,**Unequaled as Gas Enrichers.**

Analyses, prices, and all further information furnished on application to

Agency for U. S., Room 93, Nos. 2 & 4 Stone St., N.Y. City.O. J. BENHAM,
President.C. M. HIGGINS,
Secretary.L. H. SEVERANCE,
Treasurer.**The Forest City Naptha Co.,**

REFINERS OF

**Red Crown Brand
NAPTHA AND GASOLINES.**

ALSO MANUFACTURERS OF

**A Special Grade of Naptha for
Gas Companies****FOR ENRICHING COAL GAS.**

Correspondence solicited.

No. 43 Euclid Avenue, Cleveland, Ohio.

To Gas Companies.We make to order **CAP BURNERS** to burn any amount under a stated pressure. Send for samples.Also, **SERVICE CLEANERS, DRIP PUMPS, and STREET MAIN PROVING APPARATUS.****C. A. GEFRORER,**

248 N. 8th Street, Phila., Pa.

The Wilbraham Gas Exhauster,**"BAKER SYSTEM,"**

WITH ENGINE ATTACHED, ON SAME BED PLATE OR WITHOUT.

Best, Cheapest and Most Durable Exhauster known.**WILBRAHAM BROS.,**

No. 2320 Frankford Avenue, Philadelphia, Pa.

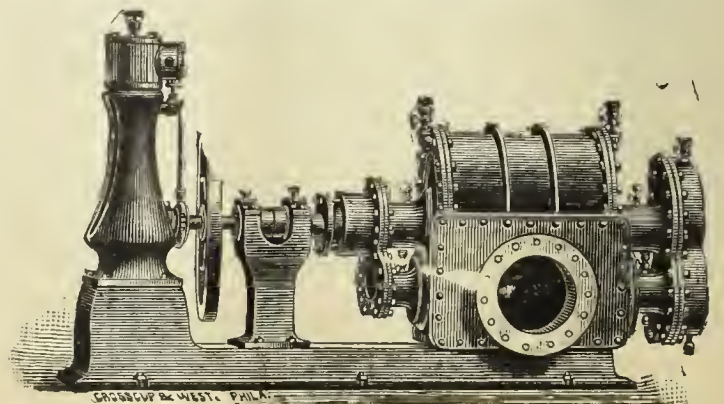

COKE CRUSHERS.

GAS COALS.

GAS COALS.

Newburgh Orrel Coal Co.,

MINERS AND SHIPPERS OF

Mountain Brook Steam and Smithing Coals,

AURORA, TYRCONNELL & PALATINE GAS COALS.

Foundry & Crushed Coke Shipped Direct from Ovens

Mines Situated at

Newburgh, Flemington & Fairmont, W. Va.

HOME OFFICE,

33 S. Gay St., Baltimore.

CHAS. MACKALL, Gen. Mangr.

CHAS. W. HAYS, Agent in New York,

Room 147, WASHINGTON BUILDING, No. 1 Broadway.

Shipping wharves at Locust Point, Baltimore.

THE DESPARD COAL COMPANY

OFFER THEIR SUPERIOR

DESPARD COAL

To Gas Light Companies and Manufacturers of Fire Clay Goods Throughout the Country.

ROUSSEL & HICKS, } AGENTS. { BANGS & HORTON, }
71 Broadway, N. Y. } 16 Kilby St., Boston. }

Mines in Harrison Co., West Va. Wharves, Locust Point, Balt.

Company's Office, 15 German St., Baltimore, Md.

Among the consumers of Despard Coal we name: Manhattan Gas Light Co., N. Y.; Metropolitan Gas Light Co., N. Y.; Jersey City, (N. J.) Gas Light Co.; Washington (D. C.) Gas Light Co.; Portland (Maine) Gas Light Co. Reference to them is requested.

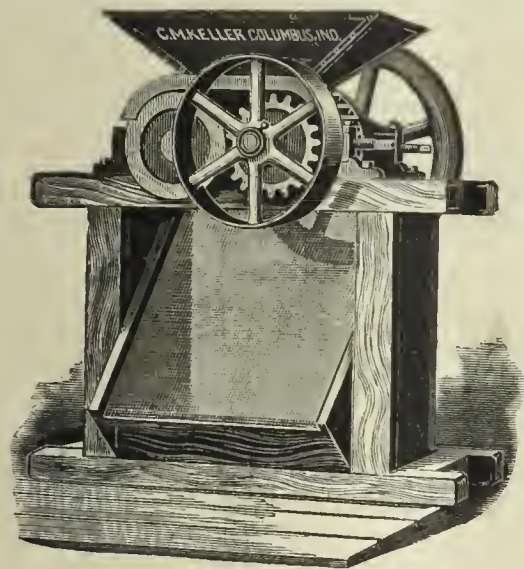

Keller's Adjustable Coke Crusher.

SIMPLE, STRONG, AND DURABLE.

C. M. Keller, Sec. & Supt. Gas Lt. & Coke Co. Columbus, Ind.

Correspondence Solicited.

GAS COMPANIES, ATTENTION!

Increase the demand for Coke by using the

Star Coke Breaker.

SIMPLE, CHEAP, DURABLE. EASILY SHARPENED BY ANY BLACKSMITH.

B. J. ALLEN, Newark Gas Co., Newark, N. J.

King's Treatise on Coal Gas.

The most complete work on Coal Gas ever published.

Three Vols. Bound, \$30.

A. M. CALLENDER & CO., 42 Pine St., N. Y.

THE PENN GAS COAL CO.

OFFER THEIR

Coal, Carefully Screened & Prepared for Gas Purposes.

Their Property is located in the Youghiogheny Coal Basin, near Irwin and Penn Stations on the Pennsylvania Railroad, and on the Youghiogheny River.

Principal Office:

209 SOUTH THIRD STREET, PHILA., PA.

Points of Shipment:

Pennsylvania Railroad Piers; Greenwich Wharves, Delaware River; Pier No. 1 (Lower Side), South Amboy, N. J.

Chesapeake & Ohio Railway Coal Agency,

FOR THE SALE OF THE

Superior Kanawha Gas Coals, Cannelton Cannel, Also, SPLINT AND STEAM COALS,

From the Kanawha and New River Regions, on the line of the Chesapeake & Ohio R'way.

C. B. ORCUTT, Sales Agent. | OFFICE, 150 BROADWAY, N. Y.

FRANCIS H. JACKSON, Presl. EDMUND H. MCCULLOUGH, V.-Presl. CHAS. F. GODSHALL, Treas. H. C. ADAMS, Sec.

THE WESTMORELAND COAL CO.

Chartered 1854.

Mines situated on the Pennsylvania and the Baltimore and Ohio Railroads, in Westmoreland County, Penn.

POINTS OF SHIPMENT:

PHILADELPHIA, BALTIMORE, SOUTH AMBOY, N. J., WATKINS (SENECA LAKE), N. Y.

Since the commencement of operations by this Company its well-known Coal has been largely used by the Gas Companies of New England and the Middle States, and its character is established as having no superior in gas giving qualities, and in freedom from sulphur and other impurities.

Principal Office, 224 South 3d St., Phila., Pa.

A. M. SCOTT, PRESIDENT. A. DEMPSTER, C.E., SECRETARY. W. K. GILLESPIE, TREASURER.

MONONGAHELA AND PETERS CREEK GAS COAL CO.,

PRODUCERS OF

Coal Bluff Gas Coal.

MINES LOCATED ON THE MONONGAHELA DIVISION OF THE PENNSYLVANIA RR., IN THE CENTRAL PORTION OF THE PITTSBURGH COAL FIELD.

Points of Shipment—Buffalo, Cleveland, Erie, Chicago, New Orleans.

Since the introduction of Coal Bluff Gas Coal it has taken rank among the few first-class Gas Coals, and acknowledges no superior in gas-giving qualities, ease of working, quality of coke, and freedom from impurities.

General Eastern Agents, ANDREW LANGDON & CO., Buffalo, N. Y.

General Western Agents, ANDREW LANGDON & CO., Chicago, Ill.

Milwaukee Agents, F. R. BUELL & CO., - - - Milwaukee, Wis.

General Office, 43 Sixth Ave., Pittsburgh, Pa.

GAS METERS.

GAS METERS.

GAS METERS.

INTERNATIONAL--1876--EXHIBITION.

The U. S. Centennial Commission

HAVE DECREED AN AWARD TO

HARRIS, GRIFFIN & CO.,

Twelfth and Brown Streets, Philadelphia, Pa. No. 49 Dey Street, N. Y. City, and No. 75 North Clinton Street, Chicago, Ill.

FOR THE FOLLOWING REASONS:

The Exhibit consists of a Series of METERS from the Largest Size Station Meters for the use of the MANUFACTURE OF GAS, to those for the use of the ORDINARY CONSUMER. The Instruments are WELL MADE, RELIABLE as to INDICATION, and embody a number of sundry improvements which, with the general character of the Exhibit, entitle the whole to commendation.

Attest—J. L. CAMPBELL,
Secretary, pro-tem.

Signed—A. T. GOSHORN,
Director General

J. R. HAWLEY,
President

NATHANIEL TUFTS,

No. 153 Franklin Street, Boston, Mass.,

MANUFACTURER OF

DRY GAS METERS.

Station Meters of any Capacity.

Test and Experimental Meters, Pressure Registers, Pressure Gauges,
Pressure and Vacuum Gauges.

METER PROVERS, PHOTOMETERS, STREET LANTERNS, ETC., ETC.

Patent Cluster Lanterns for Street Illumination.

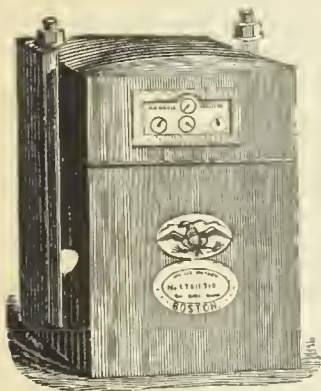

Dry Gas Meter.

With 39 years' experience and the best facilities for manufacturing, is enabled to furnish reliable work and answer orders promptly.

SCIENTIFIC BOOKS.

We are prepared to furnish to Gas Managers, and others interested in the topics treated of, the following books, at prices named:

KING'S TREATISE ON THE MANUFACTURE OF COAL GAS. Three vols.; \$10 per vol.	PRACTICAL TREATISE ON HEAT, by THOMAS BOX. Second edition. \$5.	THE GAS MANAGER IN THE LABORATORY, by a Practical Student. 8vo., Cloth. \$1.50.
GAS MANUFACTURE, by WILLIAM RICHARDS. 4to., with numerous Engravings and Plates, in Cloth binding. \$12.	GAS WORKS—THEIR ARRANGEMENT, CONSTRUCTION, PLANT, AND MACHINERY. \$8.	THE DOMESTIC USES OF COAL GAS, AS APPLIED TO LIGHTING, by W. SUGG. \$1.40.
THE GAS ANALYST'S MANUAL, by F. W. HARTLEY. \$2.50.	COAL; ITS HISTORY AND USE, by PROF. THORPE. \$3.50.	DISTILLATION OF COAL TAR AND AMMONIACAL LIQUOR by GEO. LUNGE. \$8.50.
TECHNICAL GAS ANALYSIS. \$2.80.	THE GAS WORKS OF LONDON, by COLBURN. 60 cents.	A TREATISE ON THE COMPARATIVE COMMERCIAL VALUES OF GAS COALS AND CANNELS, by D. A. GRAHAM 8vo., Cloth. \$3.
GAS MANAGER'S HANDBOOK, by THOS. NEWBIGGING. \$4.80.	THE GAS FITTER'S GUIDE, Showing the Principles and Practice of Lighting with Coal Gas, by JOHN ELDREDGE. 40 cents.	GAS AS A SOURCE OF LIGHT, HEAT, AND POWER, by C. J. R. HUMPHREYS. 10 cents.
GAS CONSUMER'S GUIDE. \$1.	GAS WORKS, AND MANUFACTURING COAL GAS, HUGHES. \$2.20.	GAS COMPANIES DIRECTORY. \$10.
A GUIDE TO GAS LIGHTING. 40 cents.	THE MANAGEMENT OF SMALL GAS WORKS, by C. J. R. HUMPHREYS. \$1.	GAS VERSUS ELECTRIC LIGHT. 50 cents.
GAS MEASUREMENT AND GAS METER TESTING, by F. W. HARTLEY. \$1.60	MANUAL FOR GAS ENGINEERING STUDENTS, by D. LEE, 40 cents.	PURIFICATION OF COAL GAS, by R. P. SPICE. 8vo. \$3.
GAS CONSUMER'S HANDBOOK, by WILLIAM RICHARDS, C.E.; 18mo., Sewed. 20 cents.	HOW TO MANAGE GAS, by F. WILKINS. Paper. 20 cents.	
A PRACTICAL TREATISE ON GAS AND VENTILATION with Special Relation to Illuminating, Heating, and Cooking by Gas, by E. E. PERKINS. \$1.25.		

The above will be forwarded by express, upon receipt of price. We take especial pains in securing and forwarding any other Works that may be desired, upon receipt of order. All remittances should be made by check, draft, or post office money order.

A. M. CALLENDER & CO., No. 42 Pine Street, New York.

KING'S TREATISE ON COAL GAS.

The most complete work on Coal Gas ever published. Three vols., bound \$30

A. M. CALLENDER & CO., No. 42 Pine Street, New York.

GAS METERS.

GAS METERS.

GAS METERS.

T. O. HOPPER, Pres. G. J. MoGOURKEY, Vice-Pres. (New York). WM. N. MILSTED, Gen. Supt. & Treas. (New York). WM. H. DOWN Sec.

AMERICAN METER COMPANY,

WET AND DRY GAS METERS.

PRESSURE REGISTERS.

METER PROVERS.

STATION METERS.

PRESSURE & VACUUM REGISTERS.

PORTABLE TEST METERS.

EXHAUSTER GOVERNORS.

PRESSURE & VACUUM GAUGES.

EXPERIMENTAL METERS.

DRY CENTRE VALVES.

CRESSON GAS REGULATORS.

AMMONIA TEST METERS.

GOVERNORS FOR GAS WORKS.

MARSLAND WATER METERS.

BAR AND JET PHOTOMETERS.

Manufactories:

512 W. 22d St., N. Y.
Arch & 22d Sts., Phila.

GAS STOVES,

SUGG'S "STANDARD" ARGAND BURNERS,
SUGG'S ILLUMINATING POWER METER,
Wet Meters, with Lizar's "Invariable Measuring" Drum.

Agencies:

177 Elm Street, Cincinnati.
214 & 216 N. Wells Street, Chicago.
810 North Second Street, St. Louis.
122 & 124 Sutter St., San Francisco

HELME & McILHENNY,

(Successors to Harris & Brother. Established 1848.)

GAS METER MANUFACTURERS,

CONTINUE AS HERETOFORE AT THE OLD ESTABLISHMENT,

Nos. 1339 to 1349 Cherry Street, Philadelphia, Pa.,

To Manufacture Wet and Dry Gas Meters, Station Meters, Experimental Meters, Meter Provers, Center Seals, Pressure Registers
GOVERNORS, INDICATORS, PHOTOMETERS, & ALL OTHER KINDS OF APPARATUS FOR USE IN GAS WORKS.

From our long practical experience of the business, and from our personal supervision of all work, we can guarantee all orders to be executed promptly and in every respect satisfactorily.

WM. WALLACE GOODWIN, Pres. and Treas.

WM. H. MERRICK, V.-Pres.

S. L. JONES, Sec.

S. V. MERRICK, Supt.

THE GOODWIN GAS STOVE AND METER COMPANY,

Successors to W. W. GOODWIN & CO.

1012, 1014 and 1016 Filbert St., Phila., Pa. 142 Chambers St., New York.
76 Dearborn St., Chicago, Ill.

WALDO BROS., Agents, 88 Water St., Boston.

MANUFACTURERS OF THE "SUN DIAL" GAS STOVES, FOR COOKING AND HEATING PURPOSES.

Dry and Wet GAS METERS, Station Meters (Square, Cylindrical or in Staves) Glazed Meters, King's and Sugg's Experimental Meters, Lamp Post Meters, Etc., Etc., Meter Provers (sizes 2, 5 and 10 feet), Pressure Gauges of all kinds, Pressure Registers, Pressure and Vacuum Registers, Pressure Indicators (sizes 4 inch, 6 inch and 9 inch), King's Pressure and Vacuum Gauges, Dry and Wet Centre Seals, Dry and Wet Governors, Exhauster Governors, Photometers of all descriptions. Letheby's Sulphur and Ammonia Test Apparatus complete—also Testing and Chemical Apparatus of all kinds, and of the most perfect description, for all purposes relating to Gas.

GOODWIN'S IMPROVED LOWE'S JET PHOTOMETER.

Agents for Bray's Patent Gas Burners and Lanterns.

Special attention to repairs of Meters, and all apparatus connected with the business.
All work guaranteed first class in every particular, and orders filled promptly.

G. B. EDWARDS, Mang'r, New York.
E. H. B. TWINING, Mang'r, Chicago.
Represented by A. B. STANNARD.

D. McDONALD & CO.,

GAS METER MANUFACTURERS.

(Established 1854.)

51 Lancaster St., Albany, N. Y. 34 & 36 West Monroe St., Chicago, Ill.

STATION METERS, EXPERIMENTAL METERS, METER PROVERS, PRESSURE & VACUUM REGISTERS, PRESSURE GAUGES, ETC.

Also STAR GAS STOVES, RANGES, and HEATING STOVES.

We use only the very best materials, and employ the most skilled labor, and by our long experience (29 years) and personal supervision of every detail, we feel justified in assuring the public that our goods will give perfect satisfaction. Every Meter emanating from our establishment will bear the State Inspector's Badge, and will be fully warranted by us. Our Annual and Calendar will be sent to Gas Companies upon application.

GAS ENGINES.

GAS ENGINES.

GAS ENGINES.

THE "OTTO" GAS ENGINE.

Guaranteed to Consume 25 to 75
Per Cent. LESS GAS than ANY OTHER GAS ENGINE
DOING THE SAME WORK.

TWIN ENGINES Impulse every revolution.
THE STEADIEST RUNNING GAS ENGINE YET MADE.

ENCINES AND PUMPS COMBINED,

For Hydraulic Elevators, Town Water Supply, or Railway Service.

Special Engines for Electric Light Work.

OVER 15,000
IN USE.

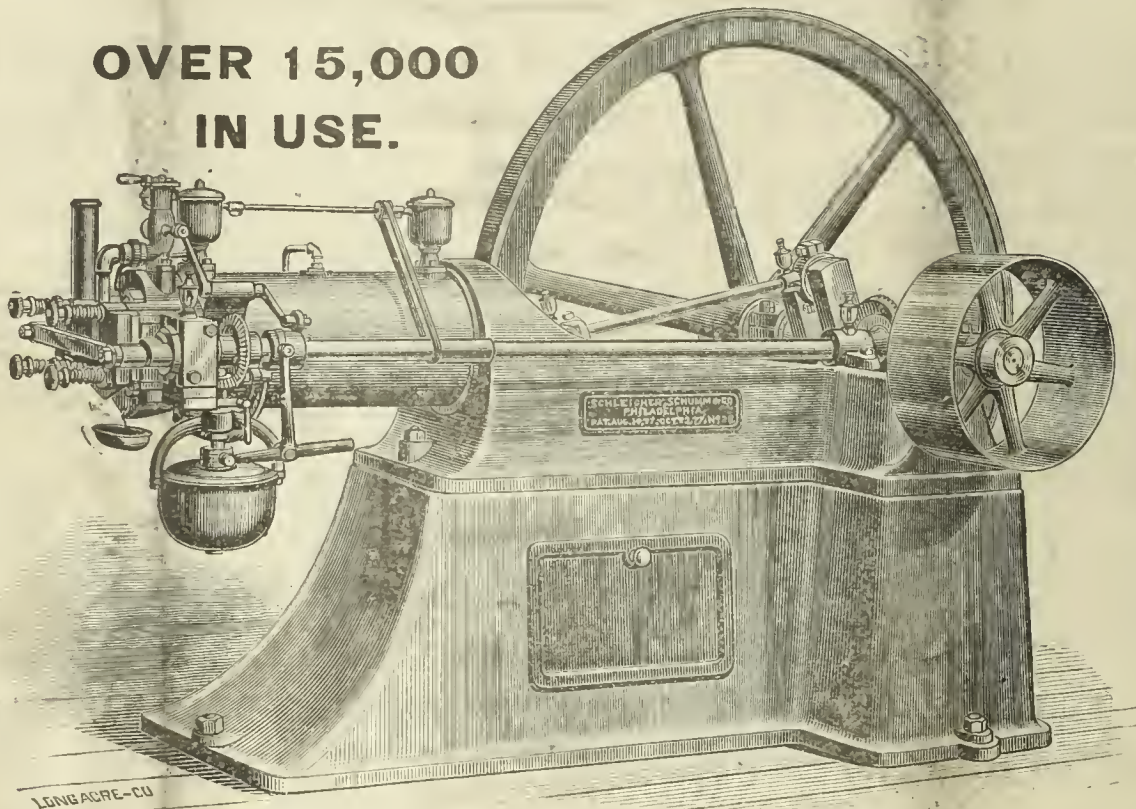

The Otto Gas Engine is now consuming, at a moderate computation, 2000 millions cubic feet of gas per year, nearly all of which is furnished during day time only.

**THE ONLY HIGHEST AWARD, ONLY GOLD MEDAL,
AT ELECTRICAL EXHIBITION, PARIS, 1881.**

MADE IN SIZES FROM 1 TO 25 HP. INDICATED.

FOR PARTICULARS, PRICES, ETC., APPLY TO

SCHLEICHER, SCHUMM & CO.,

Works:

Branch Office:

N. E. Cor. 33d & Walnut Sts., Phila., Pa.

130 Washington Street, Chicago, Ill.

THE AMERICAN

GAS LIGHT JOURNAL

REDMAN & KENNY, N. Y.

PUBLISHING OFFICE No. 42 PINE STREET

DEVOTED TO THE INTERESTS OF ILLUMINATION, VENTILATION, WATER SUPPLY AND DISTRIBUTION, & GENERAL SCIENCE.

VOLUME XLVI.—No. 5. }
Whole No. 665.

NEW YORK, WEDNESDAY, MARCH 2, 1887.

{ \$3 PER ANNUM,
IN ADVANCE.

A. M. CALLENDER & CO., Proprietors. C. E. SANDERSON, Manager.
JOS. R. THOMAS, C.E., Editor. T. J. CUNNINGHAM, Asst. Editor.

ENTERED AT THE POST OFFICE AT NEW YORK, N. Y.
AS SECOND CLASS MATTER.

Published on the 2d and 16th of each month, at No. 42 Pine Street, N. Y.

Terms of Subscription, Including Postage.—For the United States and Canada, \$3 per annum. European countries, \$3.50 (15 shillings—18 francs). All payments to be made in advance. Single copies, 15 cents.

Remittances should be made either by post-office order, registered letter, or bank draft on New York, payable to the order of A. M. Callender & Co.

Correspondence.—Wishing to make this JOURNAL a gazette of intelligent discussion to those of our readers who may wish to gain or give information on the subjects to which its columns are devoted, correspondence is solicited for publication from all who make the study of those subjects a pleasure or a profession.

The American News Company, Nos. 39 and 41 Chambers street, New York, are agents for this JOURNAL. Newsdealers will send orders to them.

CONTENTS.

An Asterisk (*) denotes an illustrated article.

OFFICIAL NOTICES—

Western Gas Association.....	129
Ohio Gas Light Association.....	129

EDITORIALS—

The New England Association's Meeting.....	130
An Astounding Proposition.....	130
Busy Constructors.....	130
Seventeenth Annual Meeting of the New England Association of Gas Engineers—Official Report.....	131

First Day, Morning Session—Roll Call—Applications for and Election to Membership—Invited to Witness the Proceedings—The Guild Tenders Hospitality—Responses and Regrets—President's Address—Committee on President's Address—Treasurer's Report—Committee on Nominations—Report of Board of Directors—Reading the Papers—The Effect of Reduction in Price of Gas, by the Hon. A. M. Norton—Discussion—Some Thoughts on Purification of Gas by Iron Oxide, by C. J. R. Humphreys—Discussion—Afternoon Session—Report of Nominating Committee—Election of Officers—The Treatment of Naphthalene, by E. G. Pratt—Discussion—Candle Power and Illumination, by C. F. Prichard—Units of Photometry, by R. B. Taber—Joint Discussion—Second Day, Morning Session—The Introduction of High Candle Power Burners, by F. S. Richardson.

* An Improvement (but on Paper only) in Apparatus for Making Gas, by Frederic Egner.....	145
* Smale's Pneumatic Hydrometer.....	146
Special English Correspondence.....	146

Temperature and Consumption of Gas—Curious Flames—The Foulis Gas Fire—The Hefner-Alteneck Photometrical Standard—Gas Business During the Second Half of 1886—The London Gas Companies.

ITEMS OF INTEREST FROM VARIOUS LOCALITIES..... 147

They Voted for Electricity—Gas Works for Dodge City, Kas.—President Morton on Measurement of Arc Lights—Capital Stock Increased—Preparin for the Near Future—Huron wants a Gas Works—Sorely Bereaved—The Test was Illegally Made—To Last for Twenty Years—Gas Legislation in California—Killed by the Current—A Big Electric Lighting Company—Another Golden State Company—Settling the Lighting Question at Xenia, Ohio—Annual Meeting at Nantucket, Mass.—Will They Succeed?—And yet Another—An Interim Dividend of Four Per Cent.—Flatbush (L. I.) Street Lighting Contract—The Worcester Hearing—Gas Engines in Fashion at St. Paul, Minn.—The American Electric Manufacturing Company—To Push the Exhauster Branch of Their Business—Annual Election, Augusta, Ga.—Annual Election, Consumers Gas Company, Chicago, Ill.—Bids for Public Lighting, Scranton, Pa.—To Provide Greater Security—The Maiden Company's Record—The Frackelton Portable Gas Kiln—It Might have been Worse—Fix up the Pipes—Tyrone, Pa., to be Lighted by Electricity—Brother Alexander's Invention—New Holder for the Springfield Gas Light Company.

CORRESPONDENCE—

Mr. Egner in Further Explanation of that "Chapter".....	149
The Market for Gas Securities.....	150

[OFFICIAL NOTICE.]

Western Gas Association.

SECRETARY'S OFFICE, QUINCY, ILL., Feb. 25, 1887.

The Tenth Annual Meeting of the Western Gas Association will be held at St. Louis, Mo., on the 11th, 12th, and 13th days of May. The Southern Hotel has been selected by the Committee of Arrangements for our abiding place, and the choice cannot fail to meet with the hearty approval of our members. With regard to a hall for our business sessions, it has been thought best to inaugurate a departure from our old-time custom of accepting (simply because it was "handy") any vacant room in the hotel building which might be placed at our disposal. Those who remember our unfortunate experience in St. Louis, three years ago, will, I am confident, give the new experiment an unqualified indorsement. A hall admirably suited to our requirements, on the corner of Sixth and Walnut streets, just one block from the Southern, has been secured by our diligent Committee, and when the hour for assembling arrives our members will applaud the selection as a most happy one. That the acoustic properties are admirable has been repeatedly demonstrated, while the size, location, and facilities of all kinds are faultless.

Your Secretary will, within a few days, send circular letters to our members generally making his regular yearly request for the preparation of essays for presentation at our Tenth Annual. Let no one feel slighted in case his name be overlooked, but get his paper ready just the same, feeling assured that it will be listened to with that rapt attention which a gas man's contribution always commands.

An effort will be made to secure reduced railway fares for those in attendance, but with what success, or lack of success, I am not now prepared to state. An announcement with respect to this matter, as well as to other topics of interest to the Association, will be made later on in these columns.

A. W. LITTLETON, Secretary.

[OFFICIAL NOTICE.]

Ohio Gas Light Association.

OFFICE OF SECRETARY, COLUMBUS, OHIO, Feb. 23, 1887.

To the Members of the Ohio Gas Light Association:—But a short time elapses before the 16th of March, the date of the Third Annual Meeting of this Association. Preparations for this meeting are under full headway, and the prospects of its success are very flattering. As stated in a former circular, there are two essentials to a good meeting—viz., a sufficient number of papers to be read and discussed, and a good attendance. The first of these requisites has been secured. All that remains is for the members of the Association, and all gas men in the State, to recognize and take advantage of the opportunity afforded by this meeting to help each other, by being present to listen to the reading of the papers, participate in their discussion, and enjoy the benefits of an interchange of ideas in private conversation.

There has probably never been a time in the history of gas lighting when questions of more importance demanded the attention of gas men than the present, and these questions are to be thoroughly discussed at the forthcoming meeting. No gas man can afford not to avail himself of this privilege of hearing discussed, in the light of recent experience and advanced thought, such subjects as "Gas Commissions," "Gas and Electricity," "Coal and

Water Gas," etc. Other subjects relating to the practical operation of gas works will be found in the following list of papers, which are promised for the meeting:

President's Address, Emerson McMillin, Columbus, O.; "Gas and Electricity—Two Interests or One?" Geo. W. Graeff, Jr., Philadelphia, Pa.; "Uniform vs. Special Rates for Gas," C. M. Converse, Delaware, O.; "Relative Cost of Coal and Water Gas," Geo. H. Christian, Jr., Norwalk, O.; "Hydraulic Lifts for Purifier Covers," Jos. Light, Dayton, O.; "Will Iron Purification Increase or Diminish Troubles Caused by Naphthaline?" John Fullager, Cincinnati, O.; "Gas Commissions," M. A. Gemuender Columbus, O.; "Is it a Good Policy for Gas Companies to Sell Gas for Stoves, Engines, etc., at a Reduced Price?" W. W. Prichard, Ironton, O.; "Choked Stand-Pipes; Is there a Remedy?" N. Kinsman, Springfield, O.; "Tar as an Enricher," E. W. Hamlin, Wilmington, O.; "Cause and Prevention of Stoppage in Burner Tips," Eugene Printz, Zanesville, O.; "Economy in the Management of a Gas Works," Moses Coombs, Jr., Youngstown, O.; "Condensation and the Elimination of Tar," T. A. Bates, Circleville, O.; "A Regenerative Furnace Adapted to a Small Works," Irvin Butterworth, Columbus, O.; "Gas with Electricity," Thos. Wood, Sandusky, O.

In addition to the foregoing, it is hoped that the President's offer of \$25 for the best and \$10 for the second best paper on the subject, "How shall we get rid of Naphthaline Crystals about the Works and still maintain High Heats?" will call forth volunteer papers.

The headquarters of the Association, and the place of its meeting, will be the Beckel House, corner of Third and Jefferson streets, Dayton, Ohio, where a rate of \$2.50 per day, for members and their families, has been secured.

The meeting will convene at 10 A.M., Wednesday, March 16, 1887, and continue two days.

IRVIN BUTTERWORTH, Secretary.

THE NEW ENGLAND ASSOCIATION'S MEETING.

That this year Dame Nature had been in a gentler mood than was the case a twelvemonth ago was made apparent to the traveler who had occasion to journey eastward at about mid-February of the past two years. The rivers seemed content with the beds allotted them, and so the bridges kept their perpendicular, with the pleasant result that the railway passenger, having discounted the "ordinary risks" of travel, could count on reaching his destination on time. With such an amelioration of the conditions upon which travel is dependent, Young's Hotel, on the evening of February 15th, contained quite a delegation of the gas men, and insured the fact that when President Harbison should on the morrow call the 17th Annual Meeting of the New England Association of Gas Engineers to order, he would be greeted by an imposing array of faces and forms "on duty bent." Perhaps it would be well to mention that early comers had handed them an *open sesame* to a certain suite of rooms in "Youngs," where a jolly set of hosts, in the persons of the Messrs. Davis, Sprague, Langford, and Waldo, stood ready to receive and welcome them. The later comers also received the same attention, and it may be said that the courtesies were heartily appreciated.

The original anticipation of an excellent attendance, representative in every respect, was more than verified when President Harbison announced the formal opening of the sessions, and those who were in attendance at the first annual meeting of the Association, held in the rooms of the Board of Trade Building, Boston, many years ago, when Mr. W. W. Greenough occupied the Presidential office, now had ample reason to be proud over the proof visible that the Parent Association had been true to the precepts of its founders. Secretary Nettleton's preliminary warnings had been heeded, and it seemed to us as if almost every New England gas man found time to be on hand. Many visitors responded to the invitations, and their names will be found in our report of the proceedings on other pages of the JOURNAL. It will be remembered perhaps that we predicted some time since what sort of presiding officer Brother Harbison would prove to be; but we hardly made the case strong enough then, for he wielded the gavel with the art of a master. We had hoped that the President's address would contain some decided personal opinion in regard to the operation of electric lighting plants by gas suppliers; but while not handling the subject in detail, perhaps his summary of the present situation could not have been more concisely or pithily put. In fact his remark concerning that matter, "The proper solution, I apprehend, must be arrived at by each individual gas company, from its own standpoint and existing circumstances and surroundings," places the point in a truthful, exact and proper light. In regard to the technical matters presented through the medium of the papers read, too much in favor of the authors' contributions cannot be said. This only shows how subjects that have been so often handled, or until one would almost claim them to have become thoroughly threadbare, can be made of extreme interest. Certainly, no other list of papers ever presented at the sessions of the New England Association gave rise to more animated and valuable discussions than those debated at the 17th annual gathering. In passing, we cannot forbear to express our

gratification at the instructions given by the Association to Messrs. Prichard and Taber to continue their researches in the perplexing field of photometry. These gentlemen are well qualified to thread their way, safely and surely, through the mazy paths of the rather obscure region which duty has mapped out for them; and we look forward to '88 for an interesting *resume* of their surveys. Mr. Humphreys, as usual, was scholarly and precise; Mr. Pratt we welcome to the field of authorship with the understanding that his fellow members are anxious to hear from him again. And, in fact, we must also place in the same category Messrs. Norton and Richardson. Indeed, we cannot blink the fact that Mr. Richardson's treatment of his subject, aside from the well displayed way in which he portrayed the principal portion of his theme, brought directly before the Association an available opportunity—one eagerly seized upon—for ventilating the merits and probable disposal of the problem involved in the joint supply of gas and electricity. This discussion, which was voluminous and searching, evidently shows that the Eastern gas men are practically unanimous on the matter; and that it is but a question of time when the fraternity of that section will have practically embarked on the seas of joint supply. Hardly less interesting was the dialogue which followed the reading of the paper presented by Nashua's Honorable gas man. Mr. Norton's figures set argument at naught, for they were simple records of what had been accomplished by the "reduction process." It goes without saying that President Harbison had "strong" opinions on this subject (he has had them for some time back), and we expect they will remain strongly within him until the dollar mark is reached—not that we mean to say that he is alone in this respect. No; he has plenty of company, and the ranks are being constantly added to. The Association may well congratulate itself on the list of papers for '87.

A particularly graceful act was the election to Honorary Membership of the distinguished gentlemen—Gen. Andrew Hickenlooper, of Cincinnati, Ohio, Mr. Emerson McMillin, of Columbus, Ohio, and Mr. Geo. A. McIlhenny, of Washington, D. C.—proposed for that honor by the Board of Directors. All of them have been tried, and nobly have they answered the tests.

To say that the banquet was a success is explained when it is mentioned that Young's *chef* was intrusted with the details; and we can only further note that President Harbison carried out the *role* of entertainer to the letter and the law. Flanked as he was by ex-Governor Littlefield, of Rhode Island, and Mr. Barker, of the Massachusetts State Gas Commission, the modest Connecticut gas man did not lose an inch of his stature. Viewed in any and every light the 17th annual was a complete success, and the record of its sessions is proof that the admonitions given to the members by ex-President Greenough, in his forceful address, delivered to many of them 17 years ago, have borne good fruit.

AN ASTOUNDING PROPOSITION.

A circular sent out to the stockholders of the Chicago (Ills.) Gas Light and Coke Company, by President E. T. Watkins, who acts on behalf of the Board of Directors, has aroused much speculation in the fraternity. The circular states that a "proposal to purchase the majority or the whole of the capital stock has been submitted to the Board of Directors, by responsible parties, at the rate of \$37.50 cash for each \$25, a premium of 50 per cent. on the par value." The circular makes no mention of the "responsible parties" by name; but does strongly recommend the owners of shares to accept the proposal. Four reasons are set forth in favor of the acceptance; but it strikes us that the "reasons" present the best possible argument against the proposed transfer. For instance, reason No. 2 starts out with the assertion, "The great increase and development in the demand for gas, created by the low price, have been insufficiently met by the capacity of our works and mains, and a large outlay will be required this year for necessary extensions." And in what more remunerative direction could money be placed than in attempting to satisfy the demand? The Company is certainly earning 8 per cent. or over on its present capital, and the "new business" assuredly ought to maintain that rate of profit on any reasonable capital extension necessary. The proposal has elicited a notice from Brown Brothers, that they are willing to take all stock that may be offered to them on a basis of \$42.50 per share of \$25. If the stock of the Chicago Company is worth so much to outsiders, why would it not be worth still more to those who now have it in their possession? Perhaps the present managers are tired of the gas business; if so, why ought they not make room for others of the present owners who are more energetically inclined?

BUSY CONSTRUCTORS.—Mr. Emil Lenz is under contract to erect seven benches of eights, on the Munich plan, in the works of the Boston (Mass.) Gas Light Company. He will also put in one bench at the works of the Derby Gas Light Company, Birmingham, Conn. This latter plant, it will be remembered, is under the management of the Secretary of the New England Association of Gas Engineers. Mr. James R. Floyd, of this city, is now engaged in putting on 70 of his patent self-sealing retort lids in the Boston Company's plant.

[OFFICIAL REPORT.]

Seventeenth Annual Meeting of the New England Association of Gas Engineers.

HELD AT YOUNG'S HOTEL, BOSTON, MASS., FEB. 16 AND 17, 1887.

FIRST DAY—MORNING SESSION—FEB. 16.

The New England Association of Gas Engineers convened in 17th annual session at Young's Hotel, Boston, Mass., at 10 A.M. on Feb. 16. The President, Mr. John P. Harbison, of Hartford, Conn., occupied the chair; and the Secretary, Mr. C. H. Nettleton, of Birmingham, Conn., recorded.

ROLL CALL.

The following members answered to their names during the progress of the roll call:

Honorary Member.

Jos. R. Thomas, Editor AM. GAS LIGHT JOURNAL, N. Y. City.

Active Members.

- | | |
|-------------------------------------|------------------------------------|
| C. T. Frost, Rockland Me. | D. Moore, Salem, Mass. |
| A. F. Cooper, Exeter, N. H. | R. J. Monks, Boston, Mass. |
| L. P. Gerould, Manchester, N. H. | G. B. Neal, Boston, Mass. |
| J. M. Hill, Concord, N. H. | J. Porter, Greenfield, Mass. |
| A. M. Norton, Nashua, N. H. | C. F. Prichard, Lynn, Mass. |
| H. A. Norton, Nashua, N. H. | E. G. Pratt, N. Attleboro', Mass. |
| John Andrew, Chelsea, Mass. | A. D. Perry, Quincy, Mass. |
| H. A. Allyn, Cambridge, Mass. | J. F. Rogers, Boston, Mass. |
| H. A. Atwood, Plymouth, Mass. | F. S. Richardson, N. Adams, Mass. |
| D. Brayton, Brockton, Mass. | J. H. Rollins, Worcester, Mass. |
| J. H. Burnham, Boston, Mass. | C. S. Spaulding, Brookline, Mass. |
| G. D. Bill, Malden, Mass. | J. Q. A. Spear, Boston, Mass. |
| D. Boynton, Chicopee, Mass. | W. H. Snow, Holyoke, Mass. |
| G. D. Cabot, Lawrence, Mass. | C. F. Spaulding, Brookline, Mass. |
| O. E. Cushing, Lowell, Mass. | W. Tarbell, Waltham, Mass. |
| H. F. Coggshall, Fitchburg, Mass. | A. W. Tarbell, Waltham, Mass. |
| D. W. Crafts, Northampton, Mass. | D. D. Tilton, Newburyport, Mass. |
| P. Coyle, Boston, Mass. | J. R. Todd, Natick, Mass. |
| J. A. Coffin, Gloucester, Mass. | R. B. Taber, New Bedford, Mass. |
| A. M. Copp, Boston, Mass. | G. Wood, New Bedford, Mass. |
| F. R. Davis, Athol, Mass. | L. W. Wells, Roxbury, Mass. |
| S. Fowler, Westfield, Mass. | W. A. Wood, Boston, Mass. |
| M. S. Greenough, Boston, Mass. | Z. M. Jenks, Woonsocket, R. I. |
| J. L. Hallett, Springfield, Mass. | S. G. Stiness, Pawtucket, R. I. |
| C. J. R. Humphreys, Lawrence, Mass. | W. A. Stedman, Newport, R. I. |
| E. Jones, Boston, Mass. | A. B. Slater, Providence, R. I. |
| M. Jewett, Clinton, Mass. | O. Gilmor, Norwich, Conn. |
| E. C. Jones, Boston, Mass. | J. P. Harbison, Hartford, Conn. |
| H. B. Leach, Taunton, Mass. | E. C. Learned, New Britain, Conn. |
| C. D. Lamson, Boston, Mass. | C. H. Nettleton, Birmingham, Conn. |
| W. A. Learned, Newton, Mass. | F. C. Sherman, New Haven, Conn. |
| G. L. Manchester, E. Hampton, Mass. | |

On motion, the minutes of the last annual meeting were approved of as published in the AM. GAS LIGHT JOURNAL.

APPLICATIONS FOR AND ELECTION TO MEMBERSHIP.

The Secretary reported that the Directors had received applications for membership from Messrs. Edward. Hassett, Supt. Beverly (Mass.) Gas Light Co.; Robt. J. Long, Asst. Supt. Salem (Mass.) Gas Light Co.; C. M. Jewett, Asst. Supt. Clinton (Mass.) Gas Light Co.; Wm. Anderson, Supt. Marlborough (Mass.) Gas Light Co.; and Wm. Badger, Supt. Concord (N. H.) Gas Light Co.; and that the Directors recommended that the above-named gentlemen be voted for by the Association.

On motion, the Secretary was instructed to cast the ballot of the Association in favor of the election of the applicants. The tellers (Messrs. Stedman and Sherman) subsequently reported that the ballot had been cast in favor of the gentlemen, and they were thereupon declared by the President duly elected members of the Association.

INVITED TO WITNESS THE PROCEEDINGS.

Mr. Stiness—We have with us to-day in Boston a number of our friends who are directly interested in what we may term our kindred industries, and I move that they be invited to take seats in our convention. The motion was agreed to, Messrs. Stiness and Leach being named as a committee to inform the visitors of the action taken.

In response to that action of the Association the following gentlemen were escorted by the committee to seats in the Convention:

Messrs. Starkes Whiton, E. T. Rowell, and F. E. Barker, who compose the Massachusetts State Gas Commission;

Also, Messrs.

- | | | | |
|-----------------|--------------------|---------------------|------------------|
| Bush, J. S. | Floyd, J. R. | McDonald, W. | Sanderson, C. E. |
| Corbett, C. H. | Graeff, G. W., Jr. | Page, G. S. | Wood, A. C. |
| Down, W. H. | Hayward, T. J. | Rowland, T. F., Jr. | White, W. H. |
| Davis, F. J. | Kreischer, G. F. | Stanley, I. N. | Weber, O. B. |
| Edwards, G. B. | Langford, J. T. | Sprague, C. H. | Waldo, C. H. |
| Flemming, D. D. | Lenz, E. | Sprague, P. W. | Waldo, J. A. |

THE GUILD TENDERS HOSPITALITIES.

The Secretary read a communication from Mr. E. G. Pratt, Secretary of the Guild of Gas Managers, tendering the members of the New England Association, during their stay in Boston, the hospitalities of the Guild's rooms.

On motion, the invitation was accepted, and the thanks of the Association tendered therefor.

RESPONSES AND REGRETS.

The Secretary announced that, by direction of the President and Directors, many invitations to attend the present meeting had been extended to prominent gas men throughout the country. Many responses to these invitations had been received. The Secretary then read letters which had been forwarded to him by Messrs. Emerson McMillin, Columbus, Ohio; J. B. Howard, Dubuque, Iowa; A. M. Smith and A. Strecker, New York city; Wm. Helme, Phila., Pa.; A. E. Boardman, Macon, Ga.; H. N. Babcock, Syracuse, N. Y.; G. G. Ramsdell, Vincennes, Ind.; and R. Spncer, Burlington, Iowa.

PRESIDENT'S ADDRESS.

The President then delivered the following inaugural address:

Gentlemen of the New England Association:—Another year has passed, and we meet here to note its events; to relate to each other and the Association our experiences, our pleasures, and our trials; to compare results, and gain new strength and encouragement for the year to come.

I find that we have on our list of membership to-day the names of two honorary and ninety active members. The report of your Treasurer, which will be laid before you, will show that there has been received during the year the sum of \$342.46. The payments during the same period have been \$284.41, leaving a balance on hand of \$909.80. Of this amount the sum of \$700 is on deposit in the Derby Savings Bank, of Derby, Conn., bearing interest at the rate of 5 per cent. per annum.

At a meeting of the Directors, held on the 1st day of January, 1887, it was voted "That the Treasurer be authorized to make such changes in the investment of the funds of the Association as he may think proper, under the direction of the President." In accordance with the above authority, and under the advice of the President, the Treasurer has transferred the funds of the Association to the Derby Savings Bank, as already stated.

At the last annual meeting of the Association it was voted "That the matter of holding a semi-annual meeting of the Association be referred to the Board of Directors." In accordance with that vote, at a meeting of the Directors subsequently held, letters were read from the members of the Board not present, and all the members present and absent (with one exception) voted orally or by writing in favor of omitting the semi-annual meeting for that year.

There has not during the year, so far as my knowledge extends, been any radical change or progress made in the manufacture or distribution of gas; but rather a steady and healthful growth. From all directions come reports of decrease in cost of production and distribution, occasioned in part by the introduction of new and improved furnaces and machinery for the manufacture and preparation of the gas for the consumers; and an increase of consumption, largely resulting from lessened selling price. In this connection it is well to note that, in a very large majority of cases, the gas companies, not only of New England but almost of the entire country, are to-day selling gas, of a greatly increased illuminating power, at about one-half the price charged ten or twelve years ago, and yet are paying a fair rate of dividend to their shareholders. All of which, I think, is greatly to the credit of the efficient managers of gas works.

During the last few years a large demand has arisen for gas for domestic purposes—that is, for heating and cooking. This being in large measure a "day" business, requiring no additional storage room, mains or service pipes to convey it, meters to measure it, or clerical force to make out, deliver, or collect the bills, is an exceedingly profitable part of the business, and enables gas companies to reduce the selling price for all their output and yet earn a fair percentage on their capital. This part of the business—which, with some companies, now amounts to from 15 to 20 per cent. of their entire output—deserves close and constant attention and encouragement.

Quite a step forward has been made during the year in the mode of consuming gas by the use of regenerative burners (notably the Lungren, and others of that general type) for illuminating large spaces, or where a strong and steady light is required. They are very much in advance of any burner heretofore introduced; and their rapid and general introduction, for the

benefit not only of the gas companies but largely so of the consumer, should be earnestly encouraged. Your special and earnest attention will be called to this important subject by a paper prepared and to be read to the Association by one of its members—one who is fully qualified to treat the subject in the exhaustive manner it deserves.

Other papers have been prepared on different subjects by various members, and they will be found to be of much practical value. I trust all of them will receive, as they deserve, your close and earnest attention, and full and complete consideration in the discussion which will take place on their merits.

Considerable attention has been given during the year, by various members of the Association, to the important subject of the utilization of residuals, in order to increase the income from the sale and disposition of coke, tar, and ammoniacal liquor; and, I learn, in some cases with marked success. I am decidedly of the opinion that much more may be accomplished in that direction; and that we may largely reduce the percentage of fuel used under the retorts, obtain a higher price for the coke and tar sold, and also receive a good return for the ammoniacal liquor—which latter has largely, heretofore, been allowed to run to waste.

Our thorough and earnest attention to this subject will, in my opinion, greatly assist us in solving the problem, which has for some time been agitating the minds of many of the members of this and other associations, of how to sell gas at *one dollar* per thousand cubic feet, and yet earn a satisfactory dividend for our shareholders. While on this subject permit me to add that the members of the New England Association must continue to occupy the "front rank" in regard to low prices. As the "parent" Association of Gas Engineers in this country, the eyes of gas men of the whole continent (as well as of the fraternity across the water) are upon us—noting our every action and advancement. They also are earnestly laboring towards the solution of the "dollar" problem. Let us not permit them to outdo us in their efforts, but continue to hold the advanced position we have so successfully obtained and maintained up to this time. A word for our encouragement on this point.

Many of the members present will remember a gathering of New England gas men, held in the city of Springfield, Mass., on the cordial invitation of our beloved (but now lamented) friend, George Dwight. Upon the entrance into the room (where all the others of the party were already seated around the hospitable board of our friend Dwight) of the last comer, he was greeted and toasted as the *Two dollar man*. In modestly returning thanks for the cordial greeting, and responding to the toast, he prophesied that within five years from that day there was scarcely a gentleman present who would be willing to admit that he was charging as much as two dollars per thousand cubic feet for his gas. How literally has that prophecy been verified! Nearly eight years has passed, and note how many gas companies in New England are to-day charging three-fourths of even the then toasted two dollar rate.

At the same ratio of reduction in price a very few years from this time will show a large proportion of at least the larger gas companies of New England, and all over the country as well, selling gas at the uniform price of *one dollar* per thousand cubic feet. Let us all do our part to hasten the arrival of that hoped-for day. Then, surely, will the gas manager's lot be a happy one—the grateful consumer alike with the happy shareholder calling down blessings upon his head. May we all live to share and enjoy the deserved happiness and blessings of such a delightful state of things.

The question of what action gas companies shall take in regard to the furnishing of electric light as a part of their business, is one that just now attracts a good share of attention. The proper solution, I apprehend, must be arrived at by each individual gas company, from its own standpoint and existing circumstances and surroundings. In regard to actual cost of maintenance and furnishing the light, I am of the opinion that very little information has been gained by outsiders during the year. If any of the members can give us additional light or information on this subject, I trust they will do so during the sessions of the Association.

A few of the members have made a new departure during the year by the introduction of a small water gas plant in their works, as an auxiliary or addition to their former facilities for making gas. I trust we shall be favored with the results, advantageous or otherwise, which they have obtained from the experiment. It has been thought by some of the members that the constitution of this Association ought to be amended so as to provide for the admission of associate members. It is well known to all that there are gentlemen intimately connected or acquainted with the business interests of gas companies, in the matter of furnishing apparatus and supplies, and who are well posted from observation in regard to the proper mode of building works and the management thereof, yet who are not practically skilled or engaged in the business. Such gentlemen, in my opinion, might well be permitted to become associate members, with the privilege and right to pay the usual initiation and yearly fee, and enjoy all the rights of active members, except those of voting and holding office. If an amendment to the constitution, pro-

viding for such membership, is presented for your consideration I heartily recommend its adoption.

Information has been received by our Secretary of the death of two of our members—Mr. Estes Howe, of Cambridge, Mass., and Mr. William C. Taber, of New Bedford, Mass. A committee to prepare a fitting and proper minute in relation thereto should be appointed.

I take much pleasure in bearing testimony to the thorough and efficient manner in which our worthy Secretary and Treasurer has performed the duties of the respective offices during the year.

Let us all, by our earnest and honest endeavors to promote, elevate, and perfect the business in which we are engaged, strive to deserve the good opinion of our friends of the profession at home and abroad; benefit the consumers of gas; continue to do justice to the shareholders in our respective companies, not forgetting that those in our employ have strong claims on us which must not be overlooked.

In conclusion, permit me to convey to you my grateful acknowledgements for the high honor conferred on me in being called by you to preside over your deliberations; and, asking your cordial assistance in the performance of my duties, let me express the hope that this the Seventeenth Annual Meeting of the New England Association may be looked back and referred to with pleasure and profit by every member.

COMMITTEE ON PRESIDENT'S ADDRESS.

On motion of Mr. Stedman a committee of three (Messrs. W. A. Stedman, F. C. Sherman, and D. W. Crafts) was appointed to consider the President's address, and to report back to the Association, during the present session, their conclusions upon the particular points contained therein that ought to be acted upon by the Association.

TREASURER'S REPORT.

The Treasurer presented and read the following annual report, which was, on motion, "received, recorded, and placed on file."

Charles H. Nettleton, Treasurer, in account with the New England Association of Gas Engineers.

	Dr.
1886.	
Feb 15. Balance.....	\$151 75
Received dues, 1886.....	\$120 00
" " 1887.....	150 00
" admission fees, meeting '86.....	10 00
	280 00
Interest from Charlestown Savings Bank.....	\$29 50
" " Warren Inst. of Savings.....	32 96
	62 46
Charlestown Savings Bank.....	\$300 00
Warren Institution of Savings.....	400 00
	700 00
	\$1,194 21
Feb. 18. L. H. Humphreys, Prop. Narragansett House.	\$341 00
Less dinner tickets.....	\$147 00
Subscription.....	65 00
	212 00
	\$129 00
Feb. 19. J. A. & R. A. Reid, dinner tickets.....	4 50
" 24. Elmwood Paper Box Co., badges.....	13 00
March 1. The Shelton Printing Co.....	16 25
" 1. The Derby Printing Co.....	9 50
April 22. A. M. Callender & Co.....	45 00
June 23. Postage, telegrams, etc., pd. C. H. Nettleton.....	8 93
1887.	
Feb. 9. Charles H. Nettleton, salary.....	50 00
" 9. The Derby Savings Bank deposit.....	700 00
" 10. Postage and telegram.....	8 23
" 12. Balance.....	209 80
	968 03
	\$1,194 21

Balance, \$209.80. Permanent fund deposited in the Derby Savings Bank, of Birmingham, Conn., \$700.

Birmingham, Conn., Feb. 12, 1887.

CHARLES H. NETTLETON, Treasurer.

We hereby certify that we have examined the Treasurer's accounts and find the same correct.

H. A. ALLYN, } Auditing
ROBT. B. TABER, } Committee.

COMMITTEE ON NOMINATIONS.

On motion of Mr. Slater, the President designated Messrs. A. B. Slater, J. L. Hallett, E. G. Pratt, Ogden Gilmor, and W. H. Snow a committee to nominate a board of officers for the ensuing year.

REPORT OF BOARD OF DIRECTORS.

The Secretary read the following report from the Board of Directors:

The Directors report that the following papers have been presented to be read before the Association:

"The Effects of Reduction in Price of Gas," by A. M. Norton; "Some Thoughts on Purifying Gas by Oxide of Iron," by C. J. R. Humphreys; "Photometric Units," by R. B. Taber; "Candle Power and Illumination," by C. F. Prichard; "Naphthaline and its Cure," by E. G. Pratt; "Introduction of High Candle Power Burners," by F. S. Richardson.

They also report the following gentlemen for election to honorary membership in the Association:

Gen. A. Hickenlooper, Cincinnati, Ohio; Mr. George A. McIlhenny, Washington, D. C.; and Mr. Emerson McMillin, Columbus, Ohio.

The President remarked that probably the first action to be taken on the report should be in regard to the recommendations for honorary membership. He thought it fitting and proper that the New England Association, as the parent body, should from time to time add to its rolls by electing to honorary membership gentlemen who had distinguished themselves in the gas profession. He believed that those whom the Directors thus sought to honor well deserved such recognition, and trusted that the recommendation would meet with unanimous approval. He thought the Association would do credit to itself by complimenting the gentlemen proposed in the manner suggested, and then asked the pleasure of the Association in the matter of the recommendation. [The Constitution provides for the election of honorary members in terms identical with those applicable to the election of active members.]

On motion of Mr. M. S. Greenough, the Secretary was directed to cast the ballot of the Association in favor of the election to honorary membership of the gentlemen named in the Director's report. The Secretary subsequently reported the result of the ballot. The nominees were declared elected, and the Secretary was instructed to inform the gentlemen of their election. [Later on in the sessions despatches were received from the nominees acknowledging the honor conferred.]

READING THE PAPERS.

The President introduced the Hon. A. M. Norton, of Nashua, N. H., who read the following paper, entitled

THE EFFECT OF REDUCTION IN PRICE OF GAS.

What the management of the Nashua (N. H.) Gas Light Company has demonstrated with reference to the results of a reduction in price should be considered with certain local features. You might be inclined to attribute a large share of the results to changes in population and business, but there has not been any extensive addition of stores or manufactories to the city—that is, bearing any proper proportion to the change in the amount of gas consumed.

The population embraces a very large percentage of operatives, but their average income and condition do not especially favor gas lighting; and the corporation buildings occupied by these operatives accommodate no unusual proportion of the whole number. In fact we think the proportion must be rather less than the average of manufacturing cities. We have a very large percentage of foreign population, occupying small tenements too cheap for gas fixtures; and it is to be noted that our increase in population has been largely of this element.

Starting out with these facts we ought to be able to establish the connection between results and their causes. January 1st, 1880, the price of gas was \$2.80 per thousand cubic feet, and the annual sendout was 11,644,950 cubic feet. On Jan. 1st, 1881, the price of gas was \$2.50 per thousand cubic feet. The sendout for that year was 13,417,410 cubic feet, or an increase, over 1880, of 15.22 per cent.

Jan. 1st, 1882, the price of gas was \$2.30 per thousand cubic feet. The sendout for 1882 was 15,092,090 cubic feet, or an increase over 1881 of 12.48 per cent.

Jan. 1st, 1883, our price was \$2.10 per thousand cubic feet. The sendout for the year 1883 was 17,058,500 cubic feet, or an increase of 12.36 per cent. over 1882.

Jan. 1st, 1884, our price was \$2 per thousand cubic feet. The sendout for 1884 was 19,172,240 cubic feet, or an increase over the year 1883 of 11.80 per cent.

Jan. 1st, 1885, our price was \$1.80 per thousand cubic feet. The sendout for 1885 was 20,717,400 cubic feet, or an increase over 1884 of 8.05 per cent.

Jan. 1st, 1886, the price of gas was \$1.60 per thousand cubic feet. The sendout for the year 1886 was 24,800,560 cubic feet, or an increase over the year 1885 of 19.70 per cent. Thus it appears that in seven years we have increased the sendout from 11,644,950 cubic feet, in 1880, to 24,800,560 cubic feet in 1886.

The increase in meters has been from 550 to 800, or about seven per cent. each year. This shows that the increased consumption is not due merely to an increase in population nor in the number of consumers.

We are satisfied that our patrons appreciate the change; and the following extract, from the *Nashua Daily Telegraph*, published soon after our last reduction, and written without solicitation or personal interest of the writer, shows the public feeling towards us:

"In the superior business advantages which this city holds out to manufacturers our gas company is one of the most public spirited. It is about the only monopoly on the earth whose record shows repeated reductions in the interests of the consumers of its product. Its example is exceptional, signal, and altogether sensible."

It will be noted that our greatest increase in consumption occurred last year, during a part of which time our customers were being switched off by electric lighting. The increased consumption by those who wanted more light in order to compare favorably with those putting in electric lamps, and who consumed more gas solely on that account, would not probably equal the loss arising from changes to electric lighting, so that we find no adequate cause for the increased consumption save in the reduced price.

We are satisfied that the only way we can maintain the popularity of gas lighting against the improved lamps for burning oil, and the use of electricity, and yearly increase the consumption, is by putting the price low. Any other policy in our city, in our judgment, would be beating against the bars of fate, and would end in waste rather than growth.

Discussion.

The President—Mr. Norton has given us a very interesting statement of the results which attended the reductions in price of gas at Nashua. I trust that others present will give their experience in this connection for the encouragement of those who have not yet made such rapid downward progress in their selling rates. No doubt Mr. Norton will be ready to answer any questions that may be asked him.

Mr. Slater—I think, Mr. President, you have had as much experience in that respect as any other member of this Association, and we would all be glad to hear from you.

The President—Our Hartford experience has been quite similar to that of Mr. Norton. In 1874 or 1875, when our price had got down to \$2.75 per thousand, we thought we were doing pretty well by the people. Our experience, much like that of gas men generally throughout the country, had been that we were earning a very good dividend for our stockholders, were trying to furnish a pretty fair light, and the people, as a rule, were pretty well satisfied; but about the time mentioned kerosene oil came to the front, and was being furnished at what we thought to be an abominably low price. The people seemed to be well satisfied with the price of oil, and enterprising dealers, taking advantage of the prevailing sentiment, introduced lamps that were well fitted to burn kerosene and obtain therefrom a very good light. As you all know, about the same time a very serious depression in the business interests of the country occurred, and people found great necessity for economizing. Finding that they could get along, by huddling around the table closely, with one kerosene lamp in rooms where they formerly had used a number of gas burners, they adopted the single lamp and cut off the gas. The result in our case was that a very large number of meters were sent from the houses and stores of our consumers back to the gas works. The meters actually came to us in wagon loads. Perhaps we tried to comfort ourselves by saying, they came in for repairs, or for repainting; but in the succeeding years we found abundance of time in which to overhaul them. Considerably over a thousand out of the five thousand then in use were returned. It finally seemed necessary, if we proposed to continue in the business of making and selling gas, that we should take a new departure; and we took it. Three months after we made up our minds to that effect we reduced our prices—first to \$2.50, then to \$2 per thousand cubic feet. The effect was that our meters, instead of coming back to the gas works, were being once more sent out from it. In three or four years our net output had decreased to about one-third of its former maximum volume; but when we reduced (1880) to \$2 per thousand cubic feet, the tide began to turn, and from 60 odd million cubic feet yearly sales (the lowest point reached at \$2 per thousand), our sendout has gone up regularly, year by year, as the price came down, from \$2 to \$1.90, then to \$1.80, to \$1.60, and \$1.40, our present selling price. The gas sold private consumers in 1886 was about seven millions cubic feet in excess of any previous year in the history of our Company. That is practically the result of our reductions in the price of gas. The policy has led to the introduction of much better means for consuming gas, in the shape of improved burners and globes; and largely in the use of gas stoves for cooking and heating. We have now something over 1,000 gas stoves in use in our city. We find that these reductions in price have worked well for us; and I think you will all have the same experience. If you will introduce, or help to introduce, gas stoves, in connection with lower prices for gas, you will find a very large increase in the amount of consumption, and as the consumption increases, you will find that the cost correspondingly decreases—not so much in the item of manufacture as in the distribution, which latter is a very important item in the cost

of gas. The increased output requires no additional holder room, nor additional meters, nor increase of clerical force. We do not find that the people generally pay us less money than they did when the price of gas was at \$2.50 or over per thousand; but they do use a greater quantity of gas, thus obtaining more light than formerly, and are much better satisfied than they were in the dark days of '75. The result summed up is that we can still earn a dividend with which our stockholders are satisfied, and that our consumers are also satisfied.

Mr. Stiness—I would like to ask Mr. Norton if his increase seemed to be derived from gas consumed for illuminating purposes; or did he have an increased quantity chargeable to the use of gas in stoves, or for manufacturing purposes?

Mr. Norton—We introduced, during the last year, a good many heating stoves, which may have had much to do with the increase shown. We did not introduce many cooking stoves until this year, but have been very successful with them. The use of gas for mechanical purposes has not increased in proportion to the gain made in the use for heating and cooking.

Mr. Taber—I believe Mr. Norton made reference in his paper to the effect that he found an obstacle to the increased use of gas in that a certain class of tenants would not pay for the gas fixtures. I would like to ask Mr. Norton if there really is such a difficulty; and if so, is it not our own fault that we cannot supply gas to that class of people? The New Bedford Company last year gave more attention to fixtures and lighting than it had ever done before; and our experience goes to show that, in the general opinion of the people, the cost of fixtures is quite a bugbear. We find it possible to put in grades of fixtures that are as cheap as any oil lamps obtainable. I noticed, when in Europe a few years ago, that almost all of the tenement buildings in England were piped for gas. The question occurred to me if it were not our own fault that we had allowed ourselves to think that gas was only for the richer classes; whether in this respect we have not made an error, and consequently have been compelled to keep up the price of gas. To my mind a great deal of money can be gained by the gas company undertaking to furnish the fixtures. Especially in view of the competition with electricity which is all about us, and with the electric lighting companies supplying their own fixtures, it seems to me advisable that gas companies should take the same stand, and supply not only the stoves (which we have been trying to introduce at New Bedford for several years), but also be ready to furnish the fixtures and to put them in—to make the contract, if necessary, to supply everything from the main to the burner. In very many cases this would save money to the consumer; and would give us the advantage of treating with the customer in a way that is sure to be very satisfactory to him. In regard to reducing the price, in New Bedford we attempted another scheme, which was to reduce the price for a given consumption. It has resulted very satisfactorily, although it developed a rather anomalous feature. We supply gas to the ordinary consumer at \$2, with 10 per cent. off, or \$1.80 net. We say to the consumer, "If you will use 4,000 feet we will sell it to you for \$1.50 per thousand. You can readily calculate that, if you burn only 3,200 feet at the long price, you will have to pay very nearly the same as the one who burns 4,000 feet." This has caused some annoyance, but, in the main, has been satisfactory, and one of the results has been that they have commenced to use gas stoves.

The President—We would like to hear what experience Mr. Greenough has had here in Boston.

Mr. Greenough—One point occurred to me, after hearing that paper, which is this: I noticed that Mr. Norton's consumption increased regularly about 10 or 11 per cent., about as fast as he brought down the price of gas, until he got to the point where the gas was *cheap*; but when he got to a point where gas was obviously cheaper than other lights the consumption took a jump. I do not think, in reducing from \$1.60 to \$1.40, one could get the same proportional increase that would occur when reducing it from \$1.80 to \$1.60. To illustrate: If a man were selling at \$3 and reduced the price to \$2.50, I question very much whether he would get a material increase in consumption. Gas would still be a luxury, for people could light more cheaply with oil. If the reduction were from \$2.50 to \$2, it would still be a question whether he would secure a material increase. But if he reduced it from \$2 to \$1.50, or so that gas was obviously a cheaper light than oil, then he would find a very decided increase in consumption. I do not think, for instance, that we would sell materially more gas in Boston if we were selling it somewhat cheaper than we are doing to-day; but if we could sell gas at \$1 instead of \$1.50, we would at once bring it very largely into uses for which other fuels are now supplied. In that case I have no doubt our consumption would very largely increase; but I do not think that a reduction from \$1.50 to \$1.35 would materially increase the gas consumption over what it is at the present time. The point I wish to emphasize is this: After gas has dropped in price, or from being a luxury to an economy, the consumption will increase enormously, as is shown by Mr. Norton's paper; but with a moderate reduction, or one still leaving the price of gas where it is

a luxury, there will not be any very marked effect upon the consumption. Such is the inference I should draw from Mr. Norton's paper.

Mr. Tarbell—We feel satisfied with the increase made in Waltham during the past 10 years, and we think it is largely due to the lessening of selling rates. Ten years ago gas was \$3.70, and the amount used by private consumers aggregated about 3½ million cubic feet; but last year we sold nearly 10 million feet, to the same class of customers, at \$2 per thousand. During that time we have increased the number of our meters from 400 to 700. My statement does not include gas sold to manufacturers, etc., for our entire yearly output is 20 millions.

The President—We would like to know what Mr. Hallett's Springfield experience has been, for he has been persistent, like some of his neighbors, in cutting rates.

Mr. Hallett—Last year we lowered our rate from \$2.30 to \$2, and our increase during that time was 7 per cent. From January 1st to 14th of February the increase was 12 per cent.; but I do not think the entire increase should be charged to the reduction, for we made quite an extensive increase in length of mains, and added a large number of meters. It is a fact, however, that—while our city has been growing, and we have year after year sent out more gas on that account—as we have increased the output we have felt it to be the best policy to reduce the price. No doubt a part of the increase came from the reduction in price, but not wholly. We are now selling gas at \$2 per thousand, with 5 per cent. off to all consumers, and 10 per cent. discount where the annual bills amount to over \$600.

Mr. Leach—Our experience at Taunton does not bear out the idea conveyed by Mr. Greenough regarding the effect of a slight reduction in gas prices. Last October we reduced from \$1.50 and \$1.75 to \$1.45 and \$1.65, and since then the increase has been over 16 per cent. It was somewhat marvelous to me, and I could not understand it for a while; but upon examining the books I ascertained that almost the entire increase came from the domestic consumption, varying with individuals from 10 to 50 per cent., which showed that the slight decrease was accountable for the net result. I presume many of you have had a similar experience. We had, during the past year, at least half a dozen letters from people who burned gas very largely, begging us not to reduce the price of gas again. [Laughter.] They said the reduction did not lessen the size of their bills; but that is because the lower the price of gas the more of it they will burn. When gas is cheap the consumers are not so economical in its use as when the charge is high.

Mr. Tarbell—In Waltham our ordinary gain was about one million cubic feet per year after each reduction; but the last reduction (when we decreased from \$2.50 to \$2 per thousand) was followed by a gain of 1,600,000. That result seems adverse to the argument (used at the time) of those who were opposed to making a reduction of 50 cents per thousand. They thought it better to reduce from \$2.50 to \$2.25, and follow with a second reduction of 25 cents. The price, however, was cut to \$2.00, and I think the gain was greatly increased thereby.

Mr. Slater—I see friend Wood, of Syracuse, N. Y., in the room. He is selling gas at a very low figure, and we would like to know what has been his experience.

Mr. Wood—I was and am here as a listener; but since I have been called upon let me state that our experience has been similar to that related by the other gentlemen. A reduction in price always resulted in a large increase in gas consumption. In 1880 we did sell some gas at \$2.50 per thousand, but in that year we lowered to \$2, and since then have gradually reduced until now we supply ordinary consumers at \$1.50, and the city at \$1.40 per thousand cubic feet. During the six years our increase in consumption has exceeded 100 per cent. Our prime object in reducing was to compete satisfactorily with kerosene oil, and at \$2 per thousand gas can do so. The latter then becomes the cheaper light. Our day consumption for mechanical and domestic purposes, has largely increased. We are now sending out, between 7 A.M. and 5 P.M., from 25 to 28 per cent. of our total daily output. Previous to 1880 the sendout during like hours did not exceed 12 per cent. of the daily output. Since the advent of the electric light our consumption has also increased. A low selling rate for gas, so far as my experience with the electric light goes, causes the latter to act as an incentive to the increased use of gas—an educator of the gas consumer that impels him to have more light. We have consumers now using burners which take up 10 and 12 feet of gas per hour, who used to swear at the gas bills when they were using four and five feet burners. I think the electric light has largely aided in the increased consumption of gas, at least that is our Syracuse experience. In Cortlandt and Homer (little New York villages, where kerosene enters largely as an element in furnishing light) the increase in gas output that attends a reduction in gas rates has not been quite so marked. We sell gas there (one company supplies both villages) at \$2, but the consumption does not increase in the same ratio that it did in Syracuse. Mr. Greenough doubts whether a slight decrease from the present selling price of gas in Boston would tend to increase the consumption. If I am correctly informed, in New

York city the reduction compelled by the Legislature to \$1.25 per thousand has resulted in an enormous increase of output. In fact I believe the Consolidated Company has had hard work to supply the increased demand. I think the effect in Boston would be similar. If he should reach Brother Harbison's figures I think he would find a large increase as the result, and perhaps there would not be so many electric lights in Boston as is now the case. I think you will find that in small villages the percentage of increase will not be as great as that which has been observed in large cities.

Mr. Greenough—I should be very sorry to have the impression go out that I am not in favor of a reduction in the price of gas at Boston, because I think it is a duty which every company owes to the community it serves to sell gas as cheaply as it can, irrespective of the effect that any reduction may have in the way of increased consumption. The question of the reduction of price of gas in Boston has often been considered by the directors of the Boston Gas Light Company (in fact it is under consideration by them at the present time), and it is only the extremely involved condition of affairs in this city at the present time that prevents their taking action. What Mr. Wood says about the village of Cortlandt seems to bear out what I said—that when you have brought the price of gas down to the point where it is cheaper than any other light, its consumption will largely increase. If he could sell his gas in Cortlandt (which I do not suppose he can) at \$1.50, his consumption would increase enormously; but in reducing it to \$2 he has not yet arrived at the point where it is cheaper than any other light. In a prosperous community gas at \$1.50 is at a price at which everybody who prefers gas can afford to burn it. I do not think he would sell much more gas at \$1.25 than he would at \$1.50. It is possible we might take away some business from the incandescent electric light people if we were selling gas 10 per cent. cheaper than we are to-day; but I do not think the increase would amount to very much, simply because the people who use the incandescent light do not use it from motives of economy. They will use it no matter what it costs, and therefore I do not think many of them would discontinue its use because the price of gas was reduced 10 per cent. Nevertheless, if we could put it so low that it could be used as a cheap fuel, then we would see an enormous increase in its consumption. Mr. Wood instances the New York companies. He must remember they had their gas at \$1.75, and that a reduction of 50 cents per thousand feet makes quite a difference. I think that \$1.75 for gas is high in a city of the size of New York.

Mr. Copp—I have had some experience, in a small way, in the matter of increasing consumption of gas by reducing its price. My first experience was secured in Plymouth, where a reduction from \$5 to \$4 per thousand was followed by a large increase. Since then, by gradual steps, the price has been brought to \$2.50 (which is a low figure for that place, where the annual output is something like 4 million cubic feet), yet the increase in consumption has been very small; in fact no increase in output followed the last reduction. Still, such happening does not count against the principle of cheap gas, for the lack of increase may be charged to the electric lighting competition in that town. The electric light company supplies about 21 of our former gas consumers, and their 7 street lights supersede 19 gas lamps. In spite of all we have been able to about hold our own, and therefore we believe an increase has followed the reduction, although the same does not show on our books. On the other hand, at Exeter, N. H. (it is a small place), a phenomenal increase followed an apparent but not an actual reduction. There the price of gas a year ago was \$3.75 gross, with 75 cents off for prompt payment, and when we determined to make the bills out at \$3, flat, the consumers seemed to think that we lowered our rates, for we have had nearly 25 per cent. increase in consumption. Perhaps, though, the increase may be also partly accounted for from the fact that last year we had a sort of contest with electricity. During the progress of the row a hearing was had before the Selectmen, at which some hundreds of our citizens appeared. I blew the "gas horn" as best I could, and the matter terminated in our favor. Somehow or other the people feel as if the gas company had helped them out, and they in turn feel like helping the gas company. We told the people that if they would increase their consumption we would reduce the price, and they seem to have taken us at our word. Whether the consumption will continue to increase when we reach the \$2.50 mark another year will show. At Rockland, Me., we have had a similar experience. We there reduced the price at one time from \$4.50 to \$3, and had a very rapid increase. Since then the increase has been small, although we have reduced the price to \$2.75. We have had little or no increase of late; but that is on account of the stagnation in business there. When business is good they will burn gas; when it is poor they discontinue the gas and burn oil.

Mr. Cushing—I have only bare facts to present. Our price is now about as low as that of any company around us, and we are probably doing as well as any of our neighbors. I cannot say exactly what increase we have had during the present year; but we have been creeping up in spite of—perhaps I might better say by the help of—the electric light. We have largely increased our consumption by the introduction of heating and cooking stoves.

This last year we made about 170 million cubic feet, and hope to make more as we go along.

Mr. Allyn—I had not the pleasure of listening to Mr. Norton's paper; but I can say that our Cambridge experience has been very similar to that reported by the other gentlemen. We are now enjoying the luxury of an electric light plant, established about three months ago. It has relieved us, so far, of the care and trouble of about 150 of our street lamps; but, notwithstanding that fact, we at present show an increase of about one million cubic feet per month, which, in our case, represents an increase of about 10 per cent. When we made our last reduction we had a President who never wanted to make a move without having figured out in dollars and cents just what the result would be. A reduction of 25 cents represented a falling off in receipts of about \$25,000 per annum, and, making a pretty liberal allowance for an increase in consumption, the best figuring he could make seemed to prove that our receipts would be about \$12,000 less than those of the previous year. In reality, however, the receipts for the twelvemonth following that reduction were but \$1,100 less than those of the former year, which proved that the people did appreciate cheap gas. We are now selling at \$1.75 to private consumers, and at \$1.50 to the city.

The President—I think Mr. Norton has reason to feel that he has done the Association good service in bringing this matter to our attention. I think the statements of the gentlemen, in relating their experience about the results gained by reducing prices, must be very encouraging to every member present. Although I heartily agree with much that has been said on the subject, yet there are some things that I dissent from. It was very gratifying to hear Mr. Wood say he had a day consumption of from 25 to 28 per cent. of his make. I wish each member would bear that statement in mind, and carry that percentage home with him and compare it with his own figures—if he has a record of similar statistics. If he does not possess such a record, then let him at once begin to make a record of the gas sent out through the year between the hours of 7 A.M. to 5 P.M. I imagine some will be surprised at the showing, and at the way in which it will increase throughout the year. I had the pleasure of showing my consumption book to some gentlemen who visited me a month ago, and I then proved to them that during December, 1886, our day business equalled 21.56 per cent. of the entire output for that month, while in January it was a little over 19 per cent. I do not agree with my friend Greenough in the statement that, after we get gas down to \$1.50, a further reduction to \$1 would not largely add to the consumption. I think it would. There is still in every city a large population unaccommodated with gas—or, rather, one that is not served with gas. In my opinion this is because, even at \$1.40 per thousand, gas will cost them more for illumination than the quantity of kerosene oil which they burn. In so speaking I do not mean that they obtain anything like as much light from the kerosene lamp as they would from gas; but in point of fact it costs them less to light their houses with kerosene oil than with gas at \$1.40, simply because they do not have as much light. If they have gas burning they do not extinguish it whenever they pass into an adjoining room; but if they are burning kerosene they carry the lamp with them. They are more extravagant in the use of gas than they are with oil. I think that class of people ought to be reached, and can be reached more and more as we lower the price of gas. I also think we have a class of population that ought to be encouraged in using gas for domestic purposes. At \$1.40 or \$1.50 per thousand, gas will, in most cases, compete with coal for cooking, at \$5 per ton. One of the great troubles encountered in this respect arises from the fact that there is not in the market a gas stove which can be bought at a price that average people feel able to pay, and I wish to emphasize that point. Some members of the gas fraternity have talked about making an effort to get out, on their own account, a stove that will meet the public want; and every manufacturing company engaged in the manufacture of these wares ought to fully appreciate the importance of this matter. I know their business, like the business of selling gas, can be largely increased; that they can make as much money by reducing the price of their stoves as we can by reducing the price of our gas. They go together hand-in-hand and cannot be separated. I believe in large sales and small profits. I hope the gas stove manufacturers will feel the importance of this suggestion, for I believe this is one of the most important subjects before us to-day as gas engineers. I believe, in Hartford, for instance, that if we should reduce the price of gas to \$1.25 (which has been talked about) we would increase our output the first year thereafter from 130 millions (it was that last year) to 150 millions. In fact I have no doubt of it. This gain would not accrue wholly from securing new consumers, but would in large measure be traceable to an increased use of gas by those who have and do now employ it for illumination but not for domestic purposes, and who would then use it for the last-named purpose. I do not quite understand Mr. Taber's idea as to gas fixtures. Does he think that gas fixtures ought to be put in at the Company's expense, or merely that the Company should do the work instead of allowing the same to be done by the plumbers?

Mr. Taber—The cost should be made as low as possible to the gas consumer.

The President—That the fixtures should be put in at cost?

Mr. Taber—For instance; a gentleman said to me the other day that it would cost him \$50 to pipe his house, and \$75 more to put in the fixtures. I offered to do the work for \$75, and secured him as a consumer. That illustrates the drift of the sentiment of the people on that subject.

The President—It is a matter well worthy the consideration of gas engineers. Up to 10 or 12 years ago a general impression prevailed among gas men that all they had to do was to make and distribute an abundant supply of good gas, and then monthly or quarterly, as the case might be, to be at their desks ready to receive the money payment of their service; but competition has taught us all a pretty good lesson, for we find it is necessary to carry on the gas business after the manner of an ordinary merchant. We must look at every detail, not only of manufacture and distribution, but must also oversee its use and encourage its employment. I think we will all find that our day business, if properly supervised, will secure to us a large increase of income, and that our additional earnings in this division will benefit us greatly in our ordinary business as light purveyors.

Mr. Taber—Apropos of the President's remarks, I am to-day somewhat in doubt whether or not to consider that I have "a leak in my main." Recently I advertised that, at the present price of coal, gas was cheaper than that material for cooking purposes; and last Friday and Saturday (Feb. 11 and 12) our day sales increased about 15,000 cubic feet. Is that increase due to a broken main, or is it to be accredited to the gas stoves?

On motion of Mr. Stiness, a vote of thanks was passed to Mr. Norton.

Mr. C. J. R. Humphreys, of Lawrence, Mass., now read his paper entitled—

SOME THOUGHTS ON PURIFICATION OF GAS BY IRON OXIDE.

I am fully aware that I am asking your attention to one of those subjects which, by common consent, has been voted threadbare; and, therefore, what I may say must lack that interest which accrues particularly to new and novel things. However, I do not offer an apology for bringing the matter before you, because I feel that these old and threadbare subjects, so called, must be taken up and considered from time to time, otherwise we may pass and repass some obscure kernel of truth, the possession of which would be of great service to us in our everyday duties as gas managers.

There are two divisions of the subject to which I would direct your attention. First, the relation of iron purification to the removal of carbonic acid from the gas; and, secondly, its bearing on the extraction of the sulphur compounds.

Some two years ago I had the honor to read before the Boston Guild of Gas Managers a paper* on "The Effect of Carbonic Acid on the Illuminating Power of Coal Gas," and it may be well to reproduce here some of the figures then given. Particularly as some of the thoughts then presented were discussed on theoretical grounds, whereas now, in one important instance at least, it will be possible to consider the matter in the light of results obtained in our everyday work.

The experiments then undertaken showed that the gas, as manufactured at our works at Lawrence, Mass., contained, after it passed the iron purifiers, 1.32 per cent. of carbonic acid. A small purifier was rigged in the photometer room, and the gas tested by the photometer to ascertain the difference in illuminating power before and after passing through the small lime purifier. The following is an analysis of the gas prior to its passage through the lime:

Analysis of Lawrence Gas made March 28, '85.

	Per Cent.
Illuminants.....	5.42
Marsh gas.....	37.24
Hydrogen.....	48.68
Carbonic oxide.....	6.04
Nitrogen.....	1.30
Carbonic acid.....	1.32

An analysis of the gas after passing through the small lime purifier showed it to be free from carbonic acid. The tests may be briefly summarized as follows. When the gas was tested by the Argand burner the presence of this 1.32 per cent. of carbonic acid knocked down the illuminating power by 0.8 of a candle; and when the flat flame burner was used the loss was 1.03 of a candle. The calculations that were then made are based on the assumption that one bushel of lime would remove this 1.32 per cent. of carbonic acid from 18,000 cubic feet of gas. This was merely a theoretical assumption; it was, however, one of vital importance, because it formed the basis of the calculation, which showed a saving of a cent in favor of using lime instead of an enricher. During the last two years we have been able to test, by our daily work, the value of this assumed figure.

At the Lawrence gas works the gas, after passing through three boxes of

iron, goes through two boxes of lime, and carbonic acid is tested for at the exit of these latter boxes with the same regularity that sulphuretted hydrogen is looked for at the outlet of the iron boxes. The gas is delivered to the lime purifiers free from sulphuretted hydrogen, so that this substance is left to deal alone with the carbonic acid; hence we have had an excellent opportunity to ascertain exactly what lime will do when it has to take care only of the carbonic acid. Strangely enough the figure which I assumed in my calculations two years ago has been found, by our two years' working, to be correct; for I find we have been using just one bushel of lime to 18,000 cubic feet of gas.

We come now to the second division of our subject, namely, the effect of iron purification on the removal from the gas of the sulphur compounds. You will remember that, theoretically, iron has no effect on the sulphur; but practically it does reduce the amount of this impurity very perceptibly. We who run gas works in the State of Massachusetts, and are forbidden to have more than 20 grains of sulphur in 100 cubic feet of gas, have been able to use iron with a considerable degree of safety; still at times, particularly in the winter season, we come unpleasantly near the statute limit. When occasionally the sulphur in our gas runs unpleasantly high I have felt annoyed that we did not understand the why and the wherefore of the matter, and were therefore unable to apply a remedy. It was in the hope that I might obtain some light on the subject that I recently turned my attention in this direction. Of course, where lime is used alone the rationale of the elimination of the sulphur is pretty well understood, and we can state the chemical changes involved by formula, for we know that the sulphuretted hydrogen combining with the lime forms the sulphate of calcium, which will, in turn, take up the bisulphide of calcium, making sulphocarbonate of lime; but with iron the case is not so satisfactory, for theoretically it has no action on the bisulphide of carbon. While I do not feel that I have as yet obtained much light on the subject, yet I lay before you the results as far as I have gone in the hope that someone else who has more time at his disposal than I have may take up the story and complete it. It was suggested to me that at my works the sulphur was not being removed in the iron boxes at all, but that it was being taken out by the lime. This seemed to me unreasonable, because the content of the lime boxes was—according to the time the material had been in use—either lime or a carbonate of lime, and those have no affinity for the bisulphide of carbon. However, to make sure of the matter, I had made simultaneously a sulphur test of the gas before and after the lime purifiers with the following result:

	Grains in 100 cu. ft.
After iron, before lime.....	15.51
After lime.....	16.94

These figures would indicate that the gas after it passed the lime contained more sulphur than before, but the difference is so small that I would attribute it to the variation which is so apt to arise in tests of this kind, and feel safe in assuming that the contained sulphur before and after the lime boxes was the same.

My next step was to have an analysis of the oxide of iron made, hoping to be able to determine what form the sulphur had taken therein. The result was as follows:

Analysis of Oxide of Iron from Lawrence Gas Works, made by Mr. C. D. Jenkins.

	Per Cent.
Sulpho cyanide of ammonium.....	9.70
Sulphate of ammonium.....	7.33
Free ammonia.....	0.13
Protosulphide of iron.....	14.70
Free sulphur.....	48.83
Insoluble residue, sand, etc.....	3.53
Water and organic matter, hydrocarbons, etc..	15.78

The iron had been used for about two years. The sample which was tested was taken with great care, so as to insure a fair average. As soon as the purifier cover was removed a shovelful of the iron was taken from a dozen different parts of the top layer; these were thoroughly mixed, and a fruit jar filled with the mixture and hermetically sealed. Another jar was filled in like manner from the material on the lower layer. When the analysis was made the contents of the two jars were thoroughly mixed and the sample taken therefrom.

The large amount of sulpho-cyanide of ammonium is surprising, and would seem to raise the conjecture whether the ammonia is the agency by which the sulphur is removed. It is fairly open to argument that such reactions might occur here, while they would not take place—or perhaps not to the same extent—in a washer or scrubber; for the ammonia is in a more concentrated form, and is presented to the gas in a more thorough manner than would be the case in the best of scrubbers. The subject is an interesting one, and worthy of further investigation.

The combination of lime and iron purification offers many advantages, because when the two are thus combined we have much less refuse lime to

*See JOURNAL, XLII., June 2, '85, p. 285.

handle, and we get rid of the nuisance occasioned by the smell from the lime, for when this material is used alone for the extraction of carbonic acid, it comes from the box in the form of an odorless carbonate of lime. The two forms of purification blend happily together; it would therefore be well if we could make ourselves thoroughly acquainted with the chemical reactions involved, so that we can act intelligently. I trust these few remarks may act as an incentive to some one to investigate the question with that completeness its importance merits.

Discussion.

Mr. Greenough—If I understood Mr. Humphreys, the result of his calculations was that it cost him more to use his lime purification than it did to put in the amount of enricher necessary to bring the gas up to the requisite candle power.

Mr. Humphreys—My calculations showed it would cost one cent less to use the lime to take out the carbonic acid than it would to make up that candle power by the use of an enricher. Of course, the expense depends upon what it costs to put the candle into the gas. I calculate on one candle, although the tests on the argand burner show only a loss of eight-tenths of a candle, while the flat-flame variety shows something more than a candle, yet I felt that the flat-flame indicated the guide to be taken, as that burner is the one used by the community. We make gas to light people's houses, and not to experiment with in the photometer room. If some one else can enrich his gas cheaper than I can, why of course that is another matter.

Mr. Allyn—Did I understand Mr. Humphreys to say that he passed his gas through two lime purifiers? Or, did he use them alternately, one at a time?

Mr. Humphreys—I have six purifiers in all; four of them worked on one centre seal are for the iron, three of them being constantly in use. From that centre seal the gas passes to two purifiers in which lime is used exclusively. At the outlet of the last iron box we test regularly, of course, for sulphuretted hydrogen, and do not let it pass through. At the outlet of the lime box we test regularly for carbonic acid, and we do not let any pass that point into the holders, at least none that will show in the regular lime test.

Mr. Allyn—How do you operate when you want to change the lime in one of these purifiers?

Mr. Humphreys—Then we run for a day on one box.

The President—If any member has had experience in the use of iron and lime together, or separately, we would like to hear from him.

Mr. Greenough—I think this paper affords an admirable example of the advantage which would come to the Association if we could get beforehand some synopsis of the papers which are to be read at our meetings. I had no idea what Mr. Humphrey's paper was to be. Had I known, I could have produced some figures which would either have sustained or disagreed with his; because, in one of our works, we are taking out the sulphuretted hydrogen first, and the carbonic acid afterwards, while in the other works we are running a set of oxide of iron purifiers singly. Now we find that in the case where we purify by oxide of iron alone, we must use very nearly half a gallon more of oil per thousand feet of gas to keep the gas at the same grade as the gas in the works where we take out the carbonic acid by means of lime. As to some of the results given in Mr. Humphrey's paper, or as to what he found could be actually done in taking out the carbonic acid, I do not know but that I could produce some figures of my own that would show quite differently. I should have been happy to have done so, had I known to what we were to listen. I think the paper is a very interesting one, but there ought to be some additional figures given here to-day on the subject. I have no doubt there are gentlemen present who can substantiate his figures.

Mr. Allyn—Like Mr. Greenough, I labored under a misconception as to what Mr. Humphrey's paper was to be. I thought he would give us the result of his use of oxide of iron for purification; that he would tell us how much he purified per bushel; how long the oxide lasted, etc. In that understanding I brought along some figures regarding the results obtained at our Cambridge works, so that I might compare them with his, but now I fear my figures may seem foreign to the subject.

The President—We shall be glad to hear them read.

Mr. Allyn—I commenced the use of oxide of iron one year ago last April, and have continued its use up to the present time. Our boxes are 20 feet square. We started by placing 500 bushels in each purifier, and I confess we had considerable misgiving about it at the outset. Located as we are, at the home of Harvard College, we have a good many professors and students who are continually experimenting on the gas, and so I did not know but that I should be brought up before the authorities to give an account of myself, yet so far I have escaped. I confess my experience as to the loss of candle power does not correspond with that of Mr. Humphrey's. I used almost precisely the same amount of oil, for an enricher, in the first year that I had used when using lime for purifying the previous year. The record of the State Inspector showed there had been a slight increase in candle power. Whether it was on account of employing the oxide or not I am unable to say. The results obtained were these: In the first month, 2,478 cubic feet per bushel were purified; in the second month, 6,738 cubic feet; in the third month, 4,959 cubic feet. The average for the first quarter was 4,725 cubic feet; for the second, 17,150 cubic feet; for the third, 11,243 cubic

feet; and for the fourth, 11,861 cubic feet. In the following year the average for the first quarter was 10,936 cubic feet; for the second, 8,112 cubic feet; for the third, 5,480 cubic feet; and thus far the present quarter has averaged 3,320 cubic feet. My idea is that our first lot of oxide has perhaps seen its best days, and my intention is to use it about two months longer, and then get a new supply. The actual expense for purification, including cost of the sponge, and of the labor expended on it for the time it has been used, averaged a trifle under one cent per thousand cubic feet. The expense for the lime purification used previously (we had to cart the lime over a long distance to and from the purifying house) averaged about two cents per thousand cubic feet.

Mr. Humphreys—Does that one cent include material?

Mr. Allyn—Yes; it covers all expenses.

The President—Does Mr. Allyn remember what his lime cost per bushel?

Mr. Allyn—We made it ourselves from shells, and it cost us about six cents per bushel.

Mr. Prichard—I think the question whether we should use iron or lime in purification is largely one of comparative cost. At our works I find that by using iron alone I can save 1½, possibly 2 cents in purifying each 1,000 cubic feet of gas. I am badly situated to obtain cheap lime, while the reverse is the case in regard to iron. Mr. Humphreys seems to be situated just the other way. We thought in the past that it was cheaper for us to allow the carbonic acid to remain and enrich the gas by using 1½ gals. of oil to 1,000 cubic feet of gas; but within the past year I have become somewhat converted to the other theory. I find that by the exclusive use of iron the amount of sulphur contained in the gas is quite plainly increased. In the State Inspector's report for the present year you will find, by examining the list of companies named, you can easily ascertain those that use iron and those that employ lime in purification. It is there very plainly marked indeed; and further, you can also ascertain the ones that make use of a mixture. In the last year I used about four inches of lime in each box, and find that, although all the carbonic acid is not extracted, it is nevertheless brought to a very low point, or to where the quantity present does not affect the candle power at all. As illustrating the efficacy or completeness of purification by the two methods, I have here analyses of gases respectively purified by iron and by lime alone. The analyses were made within a few weeks, and the quality of the gas was the same. In the lime instance the sulphur present is shown to be 6.2 grains; the iron sample shows a sulphur content of 15.4 grains. The ammonia content, in the first case, is 9.8 grains, in the other it was 3.7 grains. If we desire to improve the quality of our gas, it seems to me we must use lime entirely, or else a "happy mixture" of lime and iron.

Mr. Humphreys—I agree with Mr. Prichard, that taking out the carbonic acid or remedying it by the use of an enricher is entirely a local matter. One method may be good policy in one place, while a different course must be pursued in another situation. There are but two points in connection with my paper that seem worthy of attention. One is with regard to amount of work, practically, that a bushel of lime will do when left to deal alone with the carbonic acid. In a great many works lime is used on the trays with the iron, and there you do not have a chance to see just how much work that lime is doing; but in Lawrence using those two boxes for the carbonic acid alone we were able to see exactly how much gas a bushel of lime will purify, which, from two years' practical running, we find to be about 18,000 cubic feet. That is not a theoretical figure, but the theoretical figure assumed by me two years ago happened to agree with it. The second point of importance is the analysis of the iron. We have very few analyses of spent oxide on record, because in looking for such I only encountered one, made in 1850, I think; I believe, therefore, the analysis given in my paper is worthy of a place on the record. Showing, as it does, a large amount of sulphocyanide of ammonium, it raises the interesting question whether or not the ammonia, acting as a sort of go-between, has taken the sulphur out. I hoped by bringing the matter before you that some one who has more time than myself to investigate the question may take the story up, and show whether or not there is anything of value in the theory. I certainly intend, if possible, to investigate the matter further. I think we ought to know what we are doing, for if we are to use iron purification, and expect to take out the sulphur by it, we should make ourselves perfectly familiar with the theory of the practice.

Mr. Stiness—I would like to understand just what Mr. Humphreys means by the term "iron purification." What sort of sponge material does he use?

Mr. Humphreys—I do not apprehend there is very much difference between the different brands. What we use at Lawrence is really a mixture. We had on hand at one time considerable quantities of American iron sponge and English oxide, but in the course of working with them for years they became pretty well mixed up. In fact, we may now say the material consists of a mixture of English oxide and common sponge.

Mr. Prichard—It may be interesting to know that in the Lynn works, after removing the carbonic acid, so that only 1.95 per cent. was left, a bushel of lime purified 42,000 cubic feet and reduced the carbonic acid to a half of one per cent.

The President—Did you use your lime in the same box with the iron?

Mr. Prichard—We used it in the lower tier.

The President—That was using the lime before the iron, instead of after, as Mr. Humphreys did.

Mr. Neal—Will Mr. Humphreys state the relative size of his boxes?

Mr. Humphreys—We have four purifiers at work on iron. Two of these are 20 feet square, the other two being 10 feet by 16 feet. The two boxes used for lime are 10 feet by 16 feet.

Mr. Jones—A small item in reference to purification at the South Boston works may be interesting to the fraternity. We had much trouble during the last two or three winters with our lime purification. The lime eaked in the boxes and we were unable to account for it. So far as we could judge, the lime was neither too wet nor too dry; but at the outside we were unable to purify over 3,000 cubic feet of gas per bushel of lime. We have opened boxes when the lime was almost the same as when put in fresh. Recently we mixed in about ten per cent. of green sawdust with the lime, preparing the material on the floor of our lime house. To be more precise, we used $12\frac{1}{2}$ bushels of loose sawdust to every 130 bushels of lime; our boxes being 14 feet by 18 feet. Since that time we had no trouble from back pressure, and have been able to purify our usual amount of gas per bushel of lime. The gas in our holders has also contained considerably less ammonia than it did before we used the sawdust. I cannot account for it except upon the theory that the sawdust may be slightly acid.

Mr. Pratt—I would ask Mr. Jones if he does not attribute the caking of the lime to the manner in which he sprayed naphtha into the purifiers. I had the same trouble when I used it in that way.

Mr. Jones—Since we used this comparatively small amount of sawdust mixed with the lime we have continued to spray naphtha into the purifiers. We thoroughly believe in that practice. We have had no trouble from naphthaline since we commenced that practice.

Mr. Neal—Will Mr. Jones explain his method of spraying the naphtha?

Mr. Jones—I read a paper* on the subject two years ago, and hardly think it necessary to go over it again; but to answer the question let me say I simply put the naphtha in a can (using about 20 gallons to 130 bushels of lime in a box 14 by 18) and spray it through the plug holes under the covers of the purifiers by the aid of a common Johnson pump and a fine spray-nozzle, so as to divide the naphtha into as small particles as possible. I do this just before changing the purifiers. I then put the cap on the box, and change without blowing out any air. The naphtha carbonates the air in the box. We have no trouble from reduced candle power, and, in addition, have no trouble whatever from naphthaline.

On motion of Mr. Taber, a vote of thanks was tendered to Mr. Humphreys for his paper. The Association here ordered a recess, to terminate at 3 P.M.

FIRST DAY.—AFTERNOON SESSION.

REPORT OF NOMINATING COMMITTEE.

Mr. Slater, from the Committee appointed to present a list of officers for the ensuing year, reported the following list of nominees, and recommended their election:

President—John P. Harbison.

First Vice-President—Hon. A. M. Norton.

Second Vice-President—R. B. Taber.

Directors—Geo. B. Neal, W. A. Stedman, C. F. Prichard, H. A. Allyn, and F. S. Richardson.

Secretary and Treasurer—Charles H. Nettleton.

ELECTION OF OFFICERS.

On motion of Mr. Stiness, the report of the Committee was accepted, and the Secretary was instructed to cast the ballot of the Association for the election of the nominees. With Messrs. Stiness and Wood acting as tellers, the Secretary cast the ballot for the Association as directed, and the tellers subsequently reported a unanimous vote for the gentlemen named by the Nominating Committee.

The President—In accordance with the report of your tellers, I declare these gentlemen duly elected to serve as officers of the Association during the ensuing year. In behalf of myself, whom you have again honored by selecting me as your President, I desire to return my sincere thanks.

The President here introduced Mr. E. G. Pratt, of North Attleboro', Mass., who read the following paper on

THE TREATMENT OF NAPHTHALINE.

Having been called upon by the Secretary of our Association to contribute something to the success of our present meeting, I should feel that I had neglected a duty did I not comply with his request. And yet, in looking over the field, there seems to be no subject upon which one can give expression that has not already been discussed to such an extent, that the mere mention of the theme causes the listener to wonder what more can be said upon that question from which he can derive any information.

Many of the papers furnished at our meetings would be of little value in themselves were it not that there were points brought out in the discussion following the reading thereof from which we derived considerable benefit. Although, in this I do not expect to ad-

vance any new ideas, I shall endeavor to give you the results obtained in practice of what, to many, may still remain a theory.

Naphthaline ($C^{10}H^8$), the study of which has given rise to the most numerous and varied researches, from the double point of view of the causes of its production and the means of avoiding it.

It was for the purpose of finding out, with some degree of intelligence, whether or not my own ideas and experience would be borne out by that of others, that I mailed to some 35 managers of works a list of questions, to be answered and returned in season to tabulate. Some were what I wanted, others very incomplete, while about one-third neglected to return answers at all: so that with the press of business on my own part I have not been able to get them into shape.

The questions asked, however, were as follows:

1.—Have you been troubled with naphthaline during the past year; and to what do you attribute the cause?

2.—What distance does gas at your works have to traverse from hydraulic main to station meter?

3.—Temperature (F.) at inlet of condenser?

4.—“ (F.) “ outlet of “

5.—“ (F.) “ “ washer or scrubber?

6.—“ (F.) “ “ station meter?

7.—If you have been troubled with naphthaline, where has it shown itself first—at the works, or in the street mains and services?

My object in doing this was to find out, if possible, if at works where there was trouble from the deposition of naphthaline the conditions were not relatively the same; that is to say, that the condensing apparatus was inadequate, or the distance traversed by the gas on its passage from the hydraulic main to the station meter too short to allow of a gradual cooling from, say, 190° to 60° . I must admit that I was considerably surprised to find out, from returns received, that it was an exception where the manager reported he had been troubled with naphthaline during the year.

The conditions, as to distances, condensing surfaces, etc., hardly appear to be the same in any two localities; but still there is very little complaint from naphthaline.

The use of gas-oil or naphtha, either as an enricher, or sprayed into the purifiers, seems to be the panacea for this so-called evil. And this leads me to say, that from my own experience, while gas-oil or naphtha may serve as a solvent in the one case and a drier in the other, I do not believe their use for the purpose of getting rid of the disastrous effects of naphthaline will be found so satisfactory as that of which I am about to speak.

At the works under my charge there has been more or less trouble from naphthaline, until within the past year; and during the period of four years, through the Fall and Winter months, we have used either gas-oil or naphtha as an enricher. Our coal is not distilled at as high a temperature, probably, as at those works having regenerative furnaces, but at as high a heat, perhaps, as it is possible to attain in an ordinary setting. In the distillation of coal at high temperatures there is effected, at least, a partial distillation of the tars, the first cause of the production of naphthaline, for it is well known that, in the manufacture of naphthaline for commercial purposes, it is prepared from the distillation of tar. If, therefore, in the distillation of coal at high temperatures, naphthaline is produced from a partial distillation of the tar, it is certain that, in order to avoid any injurious effects therefrom, the separating of the gas and tar after leaving the retort must be obviated by causing the cooling process to be as slow as possible. In other words, to secure perfect condensation, the gas should be left for the longest possible time in contact with the tar.

With this in view, though I had what was considered ample condensing apparatus for a works the size of ours, I changed the arrangement of things in such a way that the gas, instead of going directly from the hydraulic main into a multitubular condenser, as formerly, now makes a complete circuit of the retort house by means of an 8-inch pipe strapped to the inner wall of building. In this way I secured an additional distance from hydraulic main to condenser of 186 feet, thus making the total distance to be traversed by the gas before reaching the station meter equal to 796 feet.

It is unnecessary for me to say that with this change my trouble from naphthaline entirely disappeared, though its effects became apparent in another way, and that in an increase of yield and illuminating power. Formerly the unsteadiness of the yields from day to day was noticeable, but now both yields and illuminating power are remarkably uniform.

The temperature of the gas in this 8-inch pipe (Feb. 14, 1887), taken directly after charging three retorts in a bench of 6's, and the

only bench being charged on this date, commencing at hydraulic main, and read at intervals of fifty feet, was as follows :

At hydraulic main.....	146	F.
50 feet distant.....	112	"
100 " ".....	101	"
150 " ".....	93	"
Inlet of condenser.....	85	"
Outlet of condenser.....	68	"
Outlet of washer.....	60	"
Outlet of station meter.....	55	"

Thus it will be noticed that there is no sudden reduction in the temperature of gas as there was when the condensing apparatus was more closely connected, and located in another room. It might be well here also to mention the fact that, before this change was made, every time a purifier was emptied there was found a quantity of tar and heavy oil in the bottom of the box that had to be removed ; but now the bottoms of boxes are perfectly dry, except occasionally, when in a box that has been filled with iron (we use part lime and part iron sponge), a deposit of heavy oil will be found, which oil is probably a portion of that injected into the retorts as an enricher.

It will, no doubt, be argued by those members who have become wedded to the use of gas-oil or naphtha as an enricher, that, if by their use a double object is secured, and they not only raise the illuminating power of their gas, but trouble from the deposition of naphthaline is avoided, what is the need of giving such particular attention to condensation, as long as the same results are secured ? If this were the case, and we had no other incentive, I am afraid the real importance of naphthaline would soon be lost sight of ; for instead of being an evil, as we have been wont to term it, properly handled, I believe it to be one of the greatest benefits to the gas maker.

To me this question is of great interest, for I believe that with our improved methods of carbonizing coal at high temperatures, the matter of cooling the gas properly is an important factor. There is no doubt, probably, in the minds of many of us, that the time is not very far distant when, from a pound of our best coals, six feet of 20 candle gas can be produced, and that without any other enricher than what may be found in the proper understanding of naphthaline and its allies.

Discussion.

Mr. Stiness—I am so fortunate as not to have had fall to my lot many of the ills common to gas men. For a number of years I have not been troubled to any extent with naphthaline. The policy marked out by Mr. Pratt is one I have acted upon for such a length of time, that I can most fully agree with the sentiments of his paper. I have never fully believed that the deposition of naphthaline was entirely due to the use of naphtha or gas-oil, and I do believe it is by reason of this method of slowly passing the gas along to the condensing apparatus, and having the latter apparatus ample, that we not only receive a benefit from what nature has placed in the black diamond, but also experience a benefit in the non-formation of naphthaline. In our Pawtucket works I have always carried the pipe on the side of the retort house as far as possible before it reached the condensing apparatus. Although it is true that every gas works must be "a law unto itself," and that what operates well in one may not do so in another, yet my experience leads me to believe that those who are afflicted with naphthaline will receive great benefit by adopting the plan mentioned. I was one of those who received a circular from friend Pratt in regard to that matter, and was compelled to reply that I could not give him any information with regard to the solution of the problem, because of the fact that I was not troubled with naphthaline. I believe an examination of my works will demonstrate that I run at about as high heats as those of the majority of gas works in New England, and so I do not think the presence of naphthaline can be attributed to high heats ; but, on the contrary, I apprehend if I were to suddenly cool my gas down from 120° to about 60°, I should be very much troubled with naphthaline.

Mr. Nettleton—During the last Fall, for the first time in several years, the works with which I am connected had some trouble from naphthaline. It came at the time when the hot scrubber, that we used for several years, was thrown out. As soon as the hot scrubber was connected the trouble disappeared at once. Singularly enough, a large works near New York was troubled in the same way, and under the same conditions ; because with the reconnection of the hot scrubber the trouble disappeared at once. That is a mere incident, but tends to corroborate the statement of Mr. Pratt—that you need a hot scrubbing surface to avoid the deposition of naphthaline.

The President—I would like Mr. Jones to state how much hot scrubbing surface he had in his retort house before the gas got to the condenser, and whether that has been changed since he began to spray with naphtha ?

Mr. Jones—Our works at South Boston are very favorably arranged. We have a long retort house, and the gas passes along the

whole length and across one end of it—say a total distance of 150 feet ; from thence down and into the exhauster room, through the exhauster ; next through the condenser and scrubbing apparatus—whose surface is ample—and thence to the purifiers. It is fully as favorable as the modern works Mr. Pratt described. There is plenty of hot scrubbing surface before the gas reaches the exhauster.

The President—And yet previous to spraying with naphtha you had trouble with naphthaline ?

Mr. Jones—Yes. The cooling of our gas between the hydraulic main and the centre of the purifiers was very gradual. It is at 125° F. when it enters the exhauster, at 80° when it leaves the condenser, and at about 75° when it leaves the first scrubber, and reaches the centre of the purifiers at a temperature of 55 to 60° F. Thus you see the gas is not subjected to any sudden shock in passing through the various pieces of apparatus.

Mr. Brayton—One time, or right after we introduced a steam jet exhauster in the works at Brockton, I discovered what naphthaline was, and could make any quantity of it. I had always supposed the exhauster should go next to the hydraulic main, and consequently placed this steam-jet as near to that point as possible. The immediate result was that my condensers became clogged from end to end, and it was only by continual and constant vigilance that I was able to keep my works in operation. Very much to my surprise, the naphthaline was all deposited within the apparatus, none reaching the inlets of the holder—not a particle ever being found outside the works while the steam-jet was in use. When the jet became too small for the capacity of the works, a rotary exhauster was introduced, and in consequence the length of pipe that the gas passed through was very much increased. After that I was not troubled with naphthaline either inside or outside of the works. I think the increase in the length of pipe is a step in the right direction. How far it is necessary to be carried of course I am unable to say.

On motion of Mr. Jones, the thanks of the Association were voted to Mr. Pratt for his paper.

Mr. C. F. Prichard, of Lynn, Mass., read the following paper, entitled

CANDLE POWER AND ILLUMINATION.

About a week ago matter which I had gathered together for this paper was suddenly destroyed by accident, and no time has since been found to repeat the tests, or to re-write many notes ; therefore, this must appear incomplete, and is not what I hoped or intended to present.

That a great discrepancy exists between candle power and illumination there seems to be no doubt. You will find men beside you who will assert confidently that a 16 candle coal-gas flame will illuminate a given room better than an 18 candle water-gas flame. You can find plenty of people, some of whom are engaged in the manufacture of both kinds of lights, who will state that a 16 candle gas flame is much better in illuminating effect than a 16 candle incandescent light. Few will deny that a 1,000 candle power gas light produces a much more satisfactory light than a nominal 2,000 candle power arc light, and it is not uncommon to hear expert electricians declare that they do not believe a person can honestly tell, from the illumination produced, whether the arc light is one of 2,000 or one of 1,200 to 1,500 candle power. Yet the photometric tests show these differences, and so many tests have been made that we cannot question the reliability of the statements.

If, however, we admit that there is any truth in the statements of discrepancy between candle power and illumination, we become forced to take the ground that at best the photometer is not a measurer of illumination. The saying that where there is smoke there is apt to be fire is true, and the prevailing opinion of the discrepancy of candle power and illumination must have some foundation in fact.

Some years ago I remember assisting in preparing a church to be lighted by means of standards among the pews carrying six gas-jets each. By my advice, the opal globes coming with the fixtures were not used, for we wished to be economical in the lighting, and I had all the text-books on gas and gas making at my back in saying that 60 per cent. of the light was lost by using an opal shade. Contrary to my expectations, the illumination was poor, and, one of the members having suggested a trial of the effect of the globes, when the soft diffusive light filled the church, my confidence in some experimenters, as well as in the photometer, received a severe shock.

Inquiry shows that in this case, as in many others, the discrepancy existing is not so much in the photometer as in our method of using it. In use the horizontal rays emitted by a flame are compared with the horizontal rays emitted by a candle, and we call this candle power, not considering the fact that rays are also emitted at every conceivable angle—above, below, and around.

One of the laws of light is that rays emitted obliquely from a surface are less intense in proportion as they are more inclined to the surface which emits them. Therefore, by this law, the rays of light from a flame, as they leave the horizontal and approach the vertical, leave the maximum measured candle power and approach the minimum of zero; also, in flat flames there is a difference of about 10 per cent. between the candle power measured from the flat side of the flame and the candle power measured from the edge. Again, in the case of the opal globes cited before F. W. Hartley found and published the fact that the light thrown downward from flat flames in opal globes was actually increased some 20 odd per cent. when measured inside of a cone whose apex was the flame and whose angle was about 40°, depending upon the size of opening of the globe, while with argand burners the light was decreased. From these examples it is seen that when we speak of a light of a certain candle power, we have not measured the total amount of light emitted from the flame, nor a quantity proportionate to the total light emitted, nor have we in the case of different lights measured even the same fraction of the light emitted. Therefore, we see that this measured candle power has almost no bearing on the illuminating value, and it is quite possible for two lights to have exactly the same candle power, measured horizontally, but to be really emitting an entirely different amount of light, and consequently have a different illuminating value.

To obtain an approximation to the illuminating value of a light, it would be necessary to measure the light emitted in a number of directions, above, below, and around, and from these calculate an average candle power. This, when done, has been aptly termed the spherical candle power, and comes much nearer being a measure of the illuminating value of a light. Besides this error in the use of the instrument—an error almost impossible to avoid in its present form—there are at least two other considerations which cause a variation.

Size and Color.—If the compared candle and gas flames were of the same size the observed candle power would be correct, so far as size is concerned; but as the size of a flame is increased so is the number of rays which are emitted obliquely increased, and these rays do not assert their true value upon the disc, but become more and more in error as this flame grows larger, and the large flame, of the same measured candle power of the smaller one, will be found, practically, decidedly the better illuminator.

A comparison on a photometer, using an opal globe for the larger light, will convince anyone that this is quite a sensible error.

Still, another advantage of size, and one well recognized by manufacturers of incandescent lights, as shown in their variously coiled filaments, is that size adds greatly to the diffusibility. The smaller the light and the more it approaches a point, or even a line, the sharper become the shadows and the darker do they appear by contrast—producing that effect so well shown in the arc light, and so foreign to true illumination.

The differences in the color of light, although not recognized to any extent by the photometer, nevertheless affect the illumination produced considerably. The natural daylight, composed of certain fixed proportions of red, orange, yellow, green, blue, indigo and violet, is the standard upon which we must base our ideas of color. Unless the light thrown upon an object has about this proportion of colored rays, it appears unnatural, and is not illuminated in the true sense of the word. For instance, we cannot illuminate a blue object by throwing upon it a red light; its outlines and form can be distinguished, but its color appears black. And so with any other color, or any combination of colors, we produce results in illumination varying greatly.

Commencing with the particles in a flame heated to a low temperature, light is produced composed mostly of red rays; as it becomes heated higher, orange is added; and, finally, the other colors of the spectrum—the proportion of red to blue or the other colors always varying—and the eye's comparative estimate of a series of colors must always depend upon the light which illuminates it.

The heavy flame of the checked burner has much more red than that of the unchecked one; the unchecked burner has more red in proportion than the argand; and the argand more than the regenerative burners, or the albo-carbon light, because the temperature per unit of light-giving surface is less, and the colored rays emitted are of the lower colors.

Similarly, a 16 candle power gas, being less rich than an 18 or 20 candle power one, may exceed it in temperature per unit of flame

area, and so produce a white light by having less red in proportion to its total light.

In the past, while in charge of a small plant near Boston, I have often been complimented upon the quality of our light, which, I was assured, was much better than Boston's. No doubt others here have had the same experience. One I knew to be 16 candle power, the other 20; but so long as we supplied a sufficient volume of light through larger burners and at higher pressure, the difference in quality appeared quite prominently, and the illumination produced was in reality better.

The effect of more pressure on a burner is very noticeable. The flame whitens at once, and the light is unquestionably better, although obtained at an expense of quantity.

The two seem to be convertible to a certain extent. A burner near the smoking point will afford more light than one with an excess of pressure; but the latter will afford a much whiter light, and one which is more pleasing to the eye. Certain burners now upon the market owe not a little of their popularity to this cause. Beside this, I am not sure but what the blue portion of the flame, previously considered of no value, is of great importance in affecting the quality of the light.

Discussion.

The President—As we have another paper (by Mr. R. B. Taber, of New Bedford, Mass.) on a kindred subject, we will now listen to it and then discuss them jointly.

Mr. Taber—Mr. Prichard and I were endeavoring to find out what Mr. Boardman meant by his experiments, as stated in his paper* read before the American Association. We each broke two chimneys over it, and neither found any satisfactory results. My only purpose in presenting this paper is in the hope that, as Mr. Prichard and myself agreed, in searching after a particular thing, the Association will go a little further in the premises, by correcting me at his expense, or him at my expense, or both of us by your superior wisdom. What I have to say reminds me very much of the story told of a fond parent, who, shouting to her friend across the street, desired to know if her little boy, who had been sent out in the mud half an hour previously, had yet got across; and the reply was that she had not seen him yet. I have floundered about in this subject very much as that boy did in the mud, and have not yet found solid ground, for the whole atmosphere of photometry, as far as I can scan it, seems shrouded in darkness.

Mr. Taber then read his paper on

UNITS OF PHOTOMETRY.

The entire atmosphere of photometry seems clouded in the vagueness of ancient barter. The Western definition (quoted with such approbation) seems to be, "Granted that the weight of the pig equals the weight of the stones; well, guess the weight of the stones!" In this day of keen competition, when intensity and luminosity have values, and are bought and sold as such, there should be, one would think, some convergence of opinion on this fundamental topic amongst gas engineers; but any examination, even the least, satisfies one of the empirical nature of the law, and the inaccuracies and errors creeping in in the examination of such a delicate subject. The very purpose of the act is largely indefinite and uncertain. A small luminous object of uncertain composition, with a consumption and height of flame dependent on the untwisting motion, absolutely uncontrolled, of a twisted thread, is made a unit of measurement of other bodies, luminous under other conditions, and often of vastly superior proportions. The very term candle power stands for the likeness of nothing existent; in fact hardly capable of imagination, since no one supposes that the light of 18 candles would behave like that of one Sugg's argand, or 2,000 like that of the electric arc.

And, to create still further distrust, the French Committee, in June last, gave M. Le Roux 800 francs as a reward for a "useful" essay on the inaccuracy of the formula (now 150 years old) of the "inverted squares of the distance," etc.; and although Dr. Krüss, of Hamburg, comes to its rescue, in the *Journal fuer Gasbeleuchtung*,† the very Doctor himself admits that with quite different degrees of brightness an open flame much distended cannot be accurately measured, without taking into account the factor dependent upon the relation of the cosines of the angle of incidence. The same Dr. Krüss has gone yet further, and demonstrated the necessity of some hitherto unexplained allowance for increase of length on the bar as the objects are more luminous; thus giving to a photometer of 20 candles 106.8 inches—an increase of 30 per cent. over the photometer of 12 candles.

*See JOURNAL, Jan 3, 1887, p. 7.
†See No. 35, 1886.

Mr. Sheard, in the English gas journal issues of last summer, adds further confusion. By his published tables the same stored gas, tested by bar and differential photometers, gave a constant rate on the differential, and rates varying 20 per cent. in the bar photometer results. And yet no one who has ever used them will call a differential photometer anything other than a relative test; in no wise can it be called a measure of light.

Again, if I continue in my iconoclasm, I have never seen any mathematical formula for applying the corrections of either the gas or candle consumption. The increment in the candle power between three and six feet consumption is so great that a manifest error is committed if any large deviation is made from the required consumption; and hence the tradition of our faith makes necessary a new test under such circumstances; but (and this is to me a source of regret) while the gas may not vary two points in 500 a candle may vary two grains in 20, and this error be multiplied largely into the result. And, again, in the matter of the discs; on which side of the dead spot will you place the true reading? Is it a success of photometry to read the figures, and then guess half a candle? The proposed search for a photometer unit, it seems to me, must be into an accurate measure, which no ordinary observers, or one observer at different times, can necessarily use for exact results expressed in terms of a unit of light.

Now, if Mr. Dibdin, in his subterranean cave in London, with a quadriform photometer, gas being at the centre, and pentane, Methven slit, candle and Keats' oil lamp, respectively, at the four extremities, can be supported by four bright-minded, intelligent men, there is reason to think one unit, at least, can be permissibly obtained. Obviously, Violle's standard, in its inconstant melting point of platinum, will never obtain in common use. Herr Alteneck's acetate of amyl is another; and one can but believe the candle and carcel are used because they can be used, almost as a matter of necessity, with no value except as a relative unit without claim to exactitude.

Again, photometry, as it is now practiced, takes little record of colors; indeed, all the laws relating to their effect on the disc are new. Besides the observation, the effect of the differing refrangibility of the diffuse rays, photometry has little or no heed to this cause of disturbance, although this must sooner or later be a subject of keen competition, since upon it depends the subject of luminosity and intensity, hitherto concealed in the similarity of the colors of candle and gas. The subject broadens out into the relationship of these two factors, divergent in their effect, but confounded in the minds of many—a relationship amounting to the entire nullification of the one in the creation of the other, as when a gas flame is lost in the luminosity of a translucent shade. It is therefore a desideratum to be sought—some photometric unit of value of both these properties of light—as illustrated in the South Foreland Lighthouse experiments, where gas and oil were found penetrating a mist at 1,400 yards, while the much larger electric light could only penetrate 100 yards further.

This whole subject comes within the province of the physicist, and not of the gas engineer, I will allow; but I find consolation in hoping that there are among us those capable of grasping the question, and carrying it to a solution. And to still further define our subject, the need of a photometer is the need of an apparatus to be an accurate measure, giving constant results, expressed in terms of a light of a certain color. We may all see the difficulty in controlling these conditions; yet it is none the less true, as I said before, we sell our goods by this measure, for practically, to a gas engineer, the subject of photometric units is valuable to solve the question of the best manufacture of his gas. The question often recurs, "Can the photometric value be expressed in the terms of any or all the different elements entering into the composition of his gas?" Every gas engineer's day-dream is for that day to arrive when, by the addition of this or the breaking up of that hydrocarbon, he may increase the little known effects of purifiers and scrubbers. It will then be a question of an algebraic formula, where a mixture of (a) illuminants, plus (b) marsh gas, plus (x) hydrogen, plus (y) nitrogen, and a little (oh! so little) naphthaline, equals the required candle power. For a help to the determinations of a, b, x, y, etc., I have had transcribed a copy of the analysis of the gas in our city, taken twice a week (over a period of six months) by our chemist, Mr. Gifford, and I have added thereto the candle power obtained and the specific gravity of the mixture.

ANALYSIS OF NEW BEDFORD GAS.

Date.	Bromine Illuminants.	CH ₄ .	H.	CO.	CANDLE POWER.		Specific Gravity
					Bar.	Jet.	
Dec. 28, 1885.	3.78	25.5	51.2	9.	19.	18.5	.111
Jan. 1, 1886.	3.58	26.2	51.9	8.6	18.6	18.8	.112
" 7, "	3.87	30.7	44.9	9.	18.2	18.5	.110
" 11, "	3.52	28.8	42.7	9.4	18.3	18.2	.108
" 18, "	3.57	30.87	43.67	8.4	17.7	18.2	.121
" 25, "	3.59	23.31	48.12	8.11	17.9	18.	.100
" 28, "	3.98	21.71	61.41	8.9	18.9	18.	.105
Feb. 1, "	3.79	26.33	53.83	8.4	18.5	17.5	.120
" 4, "	3.98	21.	55.99	10.4	17.15	17.5	.109
" 8, "	4.	23.04	54.04	9.3	17.16	17.5	.106
" 11, "	3.59	24.69	54.49	9.6	17.28	17.	.105
" 15, "	3.29	26.02	52.62	9.	17.58	17.	.138
" 18, "	3.48	25.62	50.66	9.1	16.82	16.5	.118
" 25, "	3.38	25.22	53.92	9.5	15.18	16.5	.112
Mar. 1, "	3.5	28.34	50.09	9.	17.77	16.5	.115
" 4, "	3.61	26.23	52.25	8.58	18.	16.8	.1395
" 8, "	3.58	25.13	54.13	7.8	17.7	17.	.104
" 11, "	3.68	30.16	48.59	9.1	17.49	16.5	.125
" 18, "	4.59	25.59	51.18	8.8	16.3	17.	.121
" 22, "	4.40	25.49	51.59	8.79	16.7	16.5	.119
Apr. 1, "	4.48	16.87	60.14	9.4	18.71	17.	.106
" 5, "	1.68	26.77	48.13	8.6	19.4	17.3	.118
" 12, "	3.57	21.16	59.56	8.64	18.5	17.5	.120
" 15, "	5.19	28.54	45.36	9.1	19.	17.8	.115
" 19, "	4.09	29.52	50.62	8.02	18.56	18.	.115
" 22, "	3.96	27.28	51.25	9.41	16.88	17.	.105
" 26, "	3.90	26.27	49.71	9.53	17.39	17.	.108
" 29, "	5.08	28.43	50.91	9.5	18.06	17.	.120
May 3, "	4.39	26.36	53.28	9.3	18.23	17.5	.120
" 10, "	1.69	27.79	48.28	9.31	18.6	17.5	.115
" 13, "	4.39	26.41	49.97	9.6	18.7	17.	.122
" 20, "	4.28	27.11	60.96	8.9	18.4	17.5	.130
" 21, "	4.98	28.05	48.73	9.2	18.46	17.5	.105
June 7, "	4.29	27.37	50.27	8.8	17.	17.5	.127
" 17, "	4.28	29.99	48.33	9.8	17.9	17.	.130
" 24, "	4.19	24.46	54.90	9.7	16.79	17.	.129
" 28, "	3.98	26.85	49.83	9.8	15.6	16.5	.120
July 8, "	3.79	29.61	50.72	8.6	17.63	16.5	.100
" 12, "	4.18	25.63	54.57	8.8	17.91	16.5	.105

I make no further apology for the tables other than they are true, as comparative results for the period covered, and, as such, can be maintained. It is, of course, easy to make a few cursory deductions; but I think no one cares to express his judgment at once, or off-hand. A notable feature, certainly, is the relation of illuminants, determined by bromine condensation, to the reading of the bar—quite as noticeable as the simultaneous indifference of the specific gravity. For instance:

	Candle Power.	Spec Gravity.
A low bromine condensation (3.38) gives . . .	15.8	.112
A high " (5.19) " . . .	19	.115
An intervening " (4.40) " . . .	16.7	.119
A constant bromine gave equal results with two mixtures:		
(1) 30.9 CH ₄ + 43.7 H + 8.4 CO=spec. gravity		.121
(2) 25.1 CH ₄ + 54.1 H + 7.8 CO= " "		.104

One might almost fancy in this case that the increment of CH₄ was balanced by the loss resulting from CO.

I am, however, at present entirely unable to account for some of the resultants in this essay of an epistle. It is difficult, without much thought, to grasp the subject. Why, for instance, when bromine and marsh gas are constant, should the photometer fall one-half of a candle, with an increase of hydrogen and a decrease of CO? But an increase of CH₄ was apparently able to overcome a loss of illuminants, if supported by a similar falling off in CO.

The effect of CO is plainly for evil. In one instance an increase, from 8.8 per cent. to 9.7 per cent., in a gas equally rich in illuminants, marsh gas and hydrogen, made a loss of 1.1 candles; and this is supported in another less striking instance.

Constant candle powers, to come back to our subject, are made the play of large and small quantities of marsh gas and hydrogen, and are apparently more or less dependent upon the quantities of illuminants and CO.

In any case, then, there is no such thing known to scientists as a photometric unit. The attempt to standardize a gas by its candle

power—the same problem seen from our special point of view—is complex and intensely interesting; but, to say the least, difficult. As, however, it may be probable that a gas may be synthetically produced for a certain end, that end should be clearly defined; and perhaps I may hope a discussion may be provoked which shall result in the appointment of a committee, to be a committee on Photometric Standards of our Association, endowed with sufficient funds to verify the present advances in photometric research; and to report to this body from time to time as accurate standards may seem to have been obtained.

Discussion.

The President called on Mr. Humphreys to open the discussion.

Mr. Humphreys—I think the papers are very interesting, but the subject is one that we can hardly discuss off-hand—at least, speaking for myself, I must admit I do not feel like so discussing it. No doubt there is a difference between illumination and candle power. The point was raised in October last, at the meeting of American Association, that if candle power does not mean illumination, then the whole law with regard to the diffusion of light is erroneous—I think either Mr. Prichard or Mr. Taber touched on that subject, but I would like to hear from them further with regard to it—that is to say, if candle power does not mean just what we have always thought it meant, is not our notion with regard to the diffusion of light altogether wrong? I would like to hear from these gentlemen further on this point.

Mr. Prichard—My idea is that mere candle power has nothing at all to do with the amount of illumination produced. As stated in my paper, it is quite possible for one light to emit double the amount of total rays from different portions of its surface, and yet not emit the same amount horizontally. We may say that a bull's-eye lantern will emit, in a certain direction, 16 candle power, but in another direction it will not emit anything at all, yet a gas flame placed by the side of it will emit 16 candle power in the same direction that the lantern does, but the gas flame will also send out rays in every other direction as well. Of course, we know that the gas jet gives much the best illumination, and my illustration, of course, was in an extreme case. The rays that issue from a flame vary in illuminating capacity, but they do not all vary in the same way, consequently the total illumination in a flame is entirely different from its candle power.

Mr. Taber—I would like to ask Mr. Humphreys what he understands by "candle power?" I do not understand anything at all by it. As said in my paper, you may put 18 candles upon a table, and they will have, as compared with a gas flame, neither the same diffusive power, nor anything like the same luminosity. The term "candle power" has grown up out of our indifference to the subject, rather than from anything else. If we knew what we meant by candle power we might define it. It seems to me that the introduction of arc and incandescent electric-lighting will teach us what it is. As Mr. Prichard says, a 16 candle power incandescent light is not the same as a 16 candle gas flame; nor has it the same properties.

The President—I wish Mr. Lamson would give us the benefit of his investigations on this subject.

Mr. Lamson—I have tested a good many gases, but hardly think I am competent, on the moment, to state whether we should entirely give up the use of candle power as a measure of light. I do not know any better way to measure light than to measure it horizontally; and I think it would be difficult, at the present time, for anyone of us to suggest a better way. There is no question that the amount of light delivered from any gas or electric-light flame is entirely different (when taken horizontally) from what it would be if taken by spherical measurement in a dozen different directions. I remember, when we first had arc lights in Boston, they claimed 2,000 candle power for them. Some few experiments were made by the State Inspector with regard to the illuminating power of the light, but the results of his experiments did not tally with the figures given by the electric light people. Although we know that there are a great many inaccuracies in such a method as the measurement of the horizontal rays of a candle burning a certain amount per hour, yet I think we shall have to stick to the candle power measurement for the present.

Mr. Taber—Are there any members present who use any of the other standards—as the Methven, the pentane, or the acetate of amyl?

Mr. Greenough—The Methven—yes. I will say, that, so far as the Methven standard is concerned, we have used it, and nothing else, for several years. We find it to be a more satisfactory test than the candle, more easily regulated, less liable to change of any kind, and practically agreeing exactly in color with the flame with which it is compared. Mr. Prichard made one suggestion, among others, that particularly attracted my attention, when he said that when he knew he was making 16 candle gas, the quality of that gas was compared at the expense of gases which he knew were richer. That may be true, but I do not think it agrees with my own experience in the matter. That is to say, if, for any cause, the candle power of our own gas deteriorates below the 19 candles at which we try to keep it, I notice at once the smaller amount of light-giving power possessed by it; and the public notice it also. So that, as I would infer from his statement, we should give more satisfaction if we made a 16 candle gas than we should if we made a 19 candle gas.

Mr. Prichard—Perhaps you do not apprehend what I intended to convey.

Mr. Greenough—I understood you to say there was an advantage in giving a white light over giving a yellow one, and there is no doubt that a whiter light is given by the poorer grade gases than is ordinarily given by the richer sorts. If you burn the richer gas properly, of course you can get a white light out of it. I suppose it is easier to burn a poor gas satisfactorily, than it is a good gas. The inference to be drawn would be that you get more satisfaction by giving a 12 candle gas (as in Paris) than by giving a high grade gas (as in London), and I think that some people prefer the former.

There is another thing to which my attention has been drawn, and that is this matter of the analysis of gas, presented by Mr. Taber.

It is a very curious and interesting set of figures that Mr. Taber has presented to us, where I do not see any inference that can be legitimately drawn from those figures, except, possibly, as he suggests that the presence of carbonic oxide, beyond a certain quantity, is a detriment to illuminating power; and that has been already practically determined by Mr. Hinman, the State Inspector.

I think it beyond question, that over and above the presence of a small quantity, carbonic oxide in gas serves to deteriorate its value instead of helping it. I notice that when these analyses figures of Mr. Taber are added up they do not aggregate 100 per cent.

Mr. Taber—The nitrogen is omitted.

Mr. Prichard—I do not see any carbonic acid here.

Mr. Taber—There is practically no carbonic acid in our gas after purification.

Mr. Greenough—Would there be eight or nine per cent. of nitrogen?

Mr. Taber—Yes.

Mr. Greenough—I thought there might be some other hydrocarbons besides those which are given.

Mr. Taber—No; those are all absorbed by the bromine, except the marsh gas.

Mr. Greenough—I should have said, from the experiments made daily by me for many years (although they have been abandoned for the last few years) with condensation by bromine, the candle power would follow that more closely than it seems to have done in the New Bedford instance; but, of course, these are the results of actual experiments, and as such are entitled to more weight than my recollection of what my own experiments showed. We have not yet learned from either of these gentlemen how they fared in their efforts to parallel the results obtained by Mr. Boardman, further than that they had some broken chimneys. I trust that they will give a more extended account than that, because I think it only needs something in that direction to make these two papers the most interesting ones we ever listened to in this Association.

Mr. Taber—The first time I tried the experiment with a student chimney the gas gave a candle power of 19.44. With an ordinary argand chimney it gave 16 candles. In the second experiment the results were very nearly the same, consequently I did not feel like pursuing it any further.

Mr. Prichard—In my experiments I could find no difference whatever—the results were practically identical as between the two burners, burning the same flame. I made a number of tests, and had others make them, but could see no difference in the results.

Mr. Greenough—There is another question I would like to ask Mr. Prichard. What is his judgment with regard to the comparative illuminating power of 16 candle water-gas and 16 candle coal-gas?

Mr. Prichard—I think the coal-gas flame would have a slightly larger area of flame; and, therefore, would be a slightly better illuminant.

Mr. Allyn—To follow out the point that Mr. Greenough touched upon, I think it would be interesting if he would state whether he has noticed any difference in gas where Albertite was used as an enricher, as against gas enriched with naphtha or oil.

Mr. Greenough—This whole question of the color of gas has come up within the last year or two; and in view of the new studies in photometry, and the new things to compare our light with, I have simply to trust to my recollection in the matter. We used Albertite coal during five or six years, in fact, until the mine gave out. Then for a time we used cannel, but in the last 18 months and a half we have used, practically, naphtha almost altogether. I do not think there has been any very great amount of variation in the color of the gas. For a time last Fall we gave up the naphtha, and used up some cannel that we had on hand, and I do not think there was any perceptible difference in the color of the gas. Certainly, no notice was taken by anybody as to a difference in color. Possibly Mr. Wood can give you a better answer about this than I can.

Mr. Wood—I do not think there was any material difference in color when we dropped the use of naphtha and substituted cannel for it, on account of complaints that burners were stopping up, and it was thought that the change might remedy the difficulty. We have used no Albertite during the past year.

Mr. Greenough—We dropped cannel a year ago and used naphtha, but this last Fall we ran on cannel for about a month. There was a good deal of complaint at one time (as Mr. Wood has said) in one part of the city, that the burners kept stopping up; and as it was the first year that we had employed naphtha in any large quantity, we thought it might possibly come from its use. So we abandoned it for a fortnight, and went back to cannel, to see if it had any effect. The substitution did not seem to have any effect on the burner difficulties, and the latter trouble afterwards disappeared—for the same unexplained reason that a great many other things happen.

The President—How much naphtha do you use?

Mr. Greenough—In our North End works (where we purify with lime) we used about one-half gallon of naphtha to each 1,000 cubic feet of gas; but at Commercial Point, for the reasons given this

morning, we find, in order to get the same grade of gas, we have to use nearly half a gallon more per thousand; thus we use from three-quarters to a gallon of naphtha for every thousand feet of gas we make.

Mr. Sherman—As our honorary member, Mr. Thomas, has some very decided opinions with regard to the comparative illuminating powers of coal- and water-gas, I would like to ask him for his views thereon.

The President—We shall be pleased to hear from Mr. Thomas.

Mr. Thomas—I have had for some time back very decided opinions in regard to candle power and illumination. A series of experiments made by me many years ago, in order to determine what volume of light could be obtained from one of the best descriptions of kerosene lamps, caused me to become satisfied over the question. A careful test on the photometer of the oil lamp employed showed its light to possess an illuminating value of 12 candles; but in testing the same oil lamp in comparison with a gas burner consuming five cubic feet per hour, working on 18 candle power gas, it was conclusively shown that the gas burner evolved an illuminating duty far in excess of that developed by two of the oil lamps. This, I submit, proved that candle power and illumination were widely differing things. A good practical method of determining the volume of light being emitted by either a gas or an electric light, is to turn your back to the light source, and then, while gently receding from it, note how far you can go and yet be able to read ordinary print without difficulty. Prof. Morton, in some of his experiments, found that so-called 2,000 candle power arc lights in reality gave a light which varied between 500 and 1,100 candles. I think if the intensity of this light had been measured by a photometer, it would have largely exceeded the maximum figure given. In an experiment made at one time a rated 1,000 candle power arc light, measured as accurately as was possible by the photometer, was put in a retort house, between a double stack of benches. Between other benches, similarly situated, a triple ring Sugg's argand burner was placed; the latter gave, by the photometer, a light equal to 196 candles. It was there shown satisfactorily that the gas flame gave the greater amount of illumination; that objects were more readily seen by its aid than was the case in the area illuminated by the electric light. In the city of New York, where so-called high and low (according to the photometrical tests) gas—running from 36 to 19 candles—is used, I do not believe that an observer, on seeing the gas as ordinarily burned in the stores and houses, could determine whether he was looking at the 36 or the 19 candle power article. My individual impression is that the 19 candle gas will afford the better illumination, although the photometer might try to prove the contrary.

Mr. Taber—On listening to the remarks of Mr. Thomas, it occurred to me whether it may not be with light as it is with heat. Take an ordinary small heater, and the heat becomes intense in proportion to the volume of gas consumed; but take a number of those same heaters, and you cannot develop an amount of heat proportionate to the number that you use. Can it be possible that there is a difference of intensity as distinguished from volume? Do I make myself plain? For instance, you cannot heat a steam boiler with gas. Why? Because, while you can easily boil a quart of water over a small gas burner, and convert that into steam, it seems almost impossible to develop heat enough to heat a steam boiler sufficiently to convert that larger quantity of water into steam. Is it not the same way with light?

Mr. Thomas—I think the difficulty in heating water with gas is because of the lack of proper appliances. In the natural gas district they do heat their boilers with gas, and they do it with comparatively a very small quantity. In that district I saw recently some large boilers, moving engines of 100-horse power, heated by the aid of but four gas jets. Each jet proceeded from a quarter-inch pipe. They used what might be called a crude Bunsen burner. Into a piece of pipe eight or ten inches long, a quarter-inch pipe was inserted at about one-fourth the length, and the flames coming out from the larger pipe circulated around the boiler. They were not the kind of boilers best adapted for making steam, being of the ordinary flue type. Speaking of cheap gas reminds me that this afternoon, on my way down to your assembly rooms, I met a gentleman who said that they expected very soon to introduce this fuel gas into Boston. This cheap gas, they claim, can be made at from two to six cents per thousand cubic feet. In using this gas as a fuel for heating boilers its employment was found to be cheaper than if coal had been used. On my visit to the natural gas district, I saw a boiler with a capacity of about 40 gallons heated by a single quarter-inch jet, adjusted as before mentioned, and steam was raised in 45 minutes. At Beaver Falls I saw them testing the natural gas in comparison with the manufactured product, and what seemed to me to be most singular was that the cheap, or said-to-be "two-cents-a-thousand" article, required a greater supply of air for its proper combustion than the natural gas did. As near as could be determined, it required 50 per cent. more. While in conversation with the gentleman above mentioned, he told me he had demonstrated the fact that it was not only a heating gas, but also an illuminating gas. Said he, "We have tested it here, and if you will come down we will satisfy you that it is far superior to any illuminating gas that is being sent out to-day."

The President—Is its price to be only two cents per thousand cubic feet?

Mr. Thomas—The cost of its manufacture, they claim, will run from two to six cents per thousand cubic feet. They claim they can manufacture all the way from two to six hundred thousand cubic feet of

gas from a barrel of oil; so you see there is quite a margin to be expected in its cost.

Mr. Taber—I would not like to be reported as saying it is impossible to heat a boiler with gas, for I know better; but my point is, that taking a simple, ordinary burner, and placing it under a quart of water, you can boil that quart of water. Nevertheless, place it under three gallons of water, and, practically, the water will not boil. Perhaps the light is in the same ratio, and that from a small light you can get proportionately a greater degree of illumination.

Mr. Coggsball—I would like to ask Mr. Thomas if it, the natural gas, was thus used at Beaver Falls, or was it this newly manufactured gas?

Mr. Thomas—It was the natural gas. I will also state that one or two of the large users of natural gas have purchased the right to manufacture this cheap gas; and they said that they were going to substitute it for the other. Whether they have done so or not, I cannot say.

Mr. Coggsball—An apparatus was put up in a Philadelphia saw works, but the scheme proved to be a failure.

Mr. Thomas—They have never tried this gas there to my knowledge. A syndicate, which included mill operators, purchased the right for six States, including Pennsylvania, and they proposed to introduce it into their factories. As the natural gas is brought to Beaver Falls from a point eight or ten miles distant, they concluded it would be cheaper to manufacture the gas near at hand than to pay for the transported natural gas.

Mr. Coggsball—You have not seen any of this manufactured gas in use, have you?

Mr. Thomas—No; only in the experiments.

Mr. Greenough—If Mr. Thomas will guarantee the manufacture of 600,000 cubic feet of gas out of a barrel of oil, I would be glad to be put in communication with the owners of the process.

Mr. Thomas—I have no doubt of it, Mr. Greenough.

Mr. Nettleton—I move the thanks of the Association to Mr. Prichard and Mr. Taber for their very valuable papers. The motion was carried.

The President—In connection with that motion, I would suggest that the recommendation of Mr. Taber, with reference to the appointment of a committee to yet further investigate this important subject, be carried out. I advise that those two gentlemen be specially requested by the Association to continue their investigations and experiments during the coming year, so that a year from this time they may be able to favor us with still more light on the subject.

Mr. Thomas—I move that Mr. Prichard and Mr. Taber be appointed a committee for that purpose. (Mr. Greenough suggested that the committee, if appointed, be authorized to draw upon the Treasurer in the sum of \$50, to cover expenses connected with the investigation. The suggestion was acquiesced in.)

The President—It has been moved and seconded that Messrs. Prichard and Taber be requested to continue their experiments during the ensuing year, and that they be authorized to draw upon the Treasurer for \$50 in payment of necessary expenses. There being no objection made it is so ordered.

Mr. Jones—I notice that Mr. Taber has made some use of the jet photometer in his experiments, and as there is some discrepancy between the bar and the jet, I would like to present to the Association, or to that committee, two nicely-adjusted jet photometers for use in their investigations hereafter. [Applause.]

The President—I can say in behalf of the committee, and in behalf of the Association as well, that the generous offer of Mr. Jones is accepted, with thanks.

On motion, the Association adjourned, to reconvene Thursday, February 17th, at 10 A.M.

SECOND DAY—THURSDAY, FEB. 17—MORNING SESSION.

Pursuant to adjournment, the second day's sessions were commenced at 10 A.M., February 17th.

The President now introduced Mr. F. S. Richardson, of North Adams, Mass., who read the following paper on the subject of

THE INTRODUCTION OF HIGH CANDLE POWER BURNERS.

Presuming the retort house is economically run, and the quality of gas always kept at or above 18 candles, the next vital point, at least to the manager of small works, is to know his consumers. I believe this more firmly than ever since the introduction of the "High Candle Power Burner;" and the few practical points concerning our adoption, use and sale of the Lungren Lamp, convince me it is a mistake to lose sight of that fact.

At present a serious problem for many is to discover the best course to be pursued in fortifying the basis of their business; a perplexing question to determine what aggressive line to adopt in the effort to increase the sales of gas. I believe if one becomes convinced, after some research into details of the merits of any new appliance or system for illumination, he will not be successful in winning his customers if he does not hold to that, and that alone; for it will not do to *finesse* with the public in selling gas. So many dif-

ferent burners, lamps and attachments, are now offered to gas companies, by circulars and through solicitation, that a choice seems to buy all, or none; still you need something of the kind, and finding one that combines merit and durability, to a point where you can believe in it yourself, that part of the problem is solved. It was in this manner, and through these premises, I became a convert to or a disciple of the high candle power regenerative burner, so well known to you as the Siemens-Lungren Lamp, the first one of which, with us at North Adams, was purchased last Spring, and sold to light a carpet store (24 ft. x 12 ft.) in our city. This it did perfectly, with a consumption just short of 12 cubic feet per hour; although with a little suspicion as to that quantity on the part of the purchaser. Before the month had passed we hung two more, displacing 11 oil lamps, in a grocery store, but with the same feeling of uncertainty on the part of the purchaser about the expense. Since then the lamps have sold on their merits, helped—I'll confess—by no little amount of personal solicitation, until now we have 50 of them burning. They have been placed in every class of stores and offices—dry-goods and grocery stores; millinery shops and bar-rooms; hotel offices and drug stores; with cigar and barber shops included. Every condition, save house use, we have furnished, and without a single complaint. No one that has used the lamp has given it up.

I know our experience has not been as wide as that of others in this field—for there are companies whose consumers are using a greater number of these burners; but I have, save in three instances, sold the goods, the exceptions being now on rental. If a company has a large surplus, 20 per cent. can be earned upon the investment by renting the lamp for \$1 per quarter; but there is a chance—a possibility—of the users turning to other modes of illumination, upon slighter provocation than would be the case if they owned the lamp. Yet the lamp is worth the money, for it is a fixture, burner and globe complete, and is an ornament to any room. I urge their sale because of their worth, and because their price can be saved, in the amount of gas bills, in less than a year. The parts are thoroughly made; the governor is perfect in its working, and seldom requires cleaning. Every part is duplicated, easily adjusted, and, save the asbestos flame-plate, practically indestructible. A few of our lamps have run six months without requiring any attention, whilst others need looking after occasionally. This we do not consider, as I sell the lamp, hang it, and agree to give it all necessary care for the cost at the factory. This slight concession has done more to sell the lamps than anything else, save, of course, the strength, economy, and beauty of its light. The one paramount virtue of burning gas in this regenerative burner is its cheapness; and when to that we add its cleanliness, its perfectly white and steady light, it commends itself to the most skeptical. I have urged its economy to everyone as to itself alone, except when asked to show comparison with the electric light. This ground, however, I have tried to tread delicately upon, although we have displaced three arc lights in three different places by two Lungrens in each instance. There is now a field that gas cannot fill, for everyone will not use the same light—in reality, the salvation of both systems. We all know that electricity is getting to be a paying commodity; that it has come to stay, and that for the matter of cheapening its cost to the user, the efficiency of the circuit maintained, and, in fact, the best general good to all parties concerned, it should be operated by the gas companies. We have every needed facility, and are possessed, I maintain, of the spirit of fairness and courtesy in a greater degree than is the case with the representatives of any other kind of business, in that we deal so closely with what is termed the public; but, above all, a gas company is in the lighting business. The two should be one, for the public good; and the Legislature of Massachusetts could do no better winter's work than by passing a general law sanctioning such combination, upon vote of the respective stockholders, and place both under the control of the present, and very able, Gas Commission. At this time there is absolutely no legislation regarding electric lighting. Gas companies are both protected and restricted, and I hold the same, in nature, should be given both. Asking your indulgence for this digression, I will return to my theme.

A very few facts, bearing upon general results, may, with judgment, be mentioned; but what is given is neither the result of experiments nor of close mathematical calculation. A universal adoption of these burners, in place of the ordinary lava tip, would largely reduce our sales; but the new meters set in displacement of

kerosene oil—our strongest competitor—would make up this loss, and you are placed upon a firmer and broader basis for business, whilst the amiability between the gas company and its patrons is enhanced a hundred fold. It is worth a great deal—in fact it is worth many hard dollars—to satisfy those paying large gas bills, by increasing and improving their service at reduced cost.

The strength of the light from a Lungren lamp was never better tested, with us, than by the use in the company's own office of a 16-foot burner, in place of a 6-light chandelier fitted with 6-foot tips. By the substitution we obtained more than twice the light with less than one-half the former consumption. It would seem trite to mention many of the happy results obtained by the North Adams Company in this line; but for the benefit of even the one who has not tried the lamp I may be pardoned. The store mentioned as the second user burned the two 12-foot lamps at an expense of \$2.48 per month, for the months of May, June, July and August; and since their adoption last April, up to February first of this year, with gas at \$2.25 per thousand, they have cost \$31.76. No single month shows in excess of \$4.50, and with an average of \$3.17 for the 10 months. The proprietor truthfully claims, taking into account every consideration, they cost him less than did the 11 oil lamps. A second experience is that of 19 oil lamps, hung in single file, in the length of the store, which were replaced by two Lungrens, with a result of an improved illumination, no extra expense, and entire satisfaction. One of our national banks shows beautifully the advantages of the lamp, whilst three in a corner drug store light the entire place for 15 per cent. less than was the case when lava-tip burners were used, the original illumination having been aided by kerosene. One, nestled in the corner of a very large hotel office, holds its own against its big brother, an arc light, in the centre of the room, and excites the curiosity of many and the admiration of all. Perhaps the best illustration of the difference in expense between the small burners and the use of the Lungren lamp, is shown by the bills of two drug stores—other than the one before mentioned—of exactly the same size, and doing business side by side. The former showed, for 8 months, bills amounting to \$85.29, an average of \$10.66 per month; the latter, \$41.19, an average of \$5.15—a total difference of \$44.10 or \$5.45 per month, in favor of the Lungren, besides the advantage of superior light. Here is splendidly demonstrated the saving of 50 per cent. by the use of this method of illuminating.

I find upon careful calculation, and almost 11 months' experience, that two 12-foot Lungren lamps light the same internal area equally as well as would be done by a full arc light, with the positive advantage of two points of distribution, a light that is white, perfectly steady, and under one's own control. They cannot pass and consume more gas than claimed, so the expense may be calculated to a nicety. A comparison, with a charge of, say, 40 cents per night for an arc light, and gas at or about \$2 per thousand, shows that two Lungrens will burn one year for one-half the expense of the arc, and light the same space. The heat generated is urged against their use; yet, in this climate, eight months of the year their heat is a benefit, during two more it is not noticed, and the remaining ones (say July and August), every door and window is open, and the time for burning is so short, that, unless the ceilings happen to be very low, the heat is imperceptible. Excellent results have been obtained by their use out-of-doors, *i. e.*, under porches and awnings, during summer time.

The lamp is so very cleverly constructed that it is simple, and still every vital point is nicely covered. It seems, at present, to be the very perfection of gas burning, with but one objection—which certainly is an objection—the first cost of the lamp. Most assuredly I say nothing to reflect upon the business tact and ability of Brothers Stein and Brognard, for I feel sure they quote them as low as possible; but why the easy, graceful and ornamental little concern should cost \$20 and upwards, net, is a mystery. This fact alone hinders a veritable landslide toward their adoption; and could increased facilities in their manufacture cheapen their production, 24 hours each day would be too short a time in which to fill the orders. They would sell on sight, as one mention will show. Besides a single order for 60, for use in a gingham mill, I have lost an equal number from the cost. Yet, even at the present price, they are the most inexpensive method of illumination for the purposes designed; and, if the worthy President of the Company shows but his past energy, I predict the faternity will soon receive notice of a "cut in rates" from Philadelphia, followed by our wishes for "many happy returns of the day".

[To be continued.]

An Improvement (but on Paper Only) in Apparatus for Making Gas.

By FREDERIC EGNER.

Some years ago, when the author acted as engineer-in-charge of the plant of a small Southern gas company, he was fortunate to serve under a gentleman who, as President of that company, was not only not a mere figurehead, but, on the contrary, being well versed in the practical details of the business, took pleasure in discussing the same frequently with the writer. It was after one of these pleasant exchanges of views, on matters connected with the manufacture of gas, that the apparatus herewith illustrated was conceived. It is true the machine was never built, but remained "an improvement in apparatus for the manufacture of illuminating gas" on paper only—like so many more pretentious inventions of to-day are, in fact, but to which our attention is called frequently by the positive assertions of their progenitors in respect of what the apparatus could accomplish were the same once put into practical operation.

It is sometimes interesting and instructive to read about the attempts—even if they were but failures after all—of others; and, thus viewing the case, a description of that all-but-forgotten invention of the writer's may, perhaps, be looked over with interest by the professional readers of this JOURNAL.

The illustration represents a cross-sectional view of a side elevation of the apparatus, and the reference letters may be thus explained. *H* is a hopper or coal receiver, closed air-tight at the top by the removable door *O*. Several of these doors are placed in desirable positions on the apparatus. *VV* are valves, to use as occasion might require. It had been intended to employ water-cooled valves, somewhat similar to those invented since that time by Leadly. *R* is a cast iron retort, cylindrical in form, divided internally into a number of compartments by means of annular lips or flanges and longitudinal ribs or partition pieces. The retort rests, at both ends, on half-pillow blocks composed of small rollers—but not clearly shown in the cut. It is closed at the extremities, and still further supported and kept in place, by one stationary and one movable mouthpiece. The movable mouthpiece *A* at upper end rests on the inclined slide *P*, which, being in the same plane as the axis of the retort, allows for expansion or contraction of the same. Between the hopper *H* and the movable mouthpiece *A* the joint is effected by the tar, water, or sand lute *L*; *P* and *H* being supported independently by beam *B* and suitable pillars. *G* is a water gas generator, or the coke chamber, provided with doors *DD*, also a blast pipe and steam connections at *I*. *CC* are hot air chambers or flues for the passage of the combustion gases. *S* is the superheater or fixer for the gas. *Z* is a pipe for leading off the generated illuminating gases to the purifying apparatus.

The process of gas making in this apparatus was to be as follows: The hopper being filled with coal, the air-tight cover closed, and the retort brought to a dull-red heat—say about 980°, at which temperature it was to be maintained throughout the operation—the retort is caused to slowly revolve by means of a cog-wheel keyed upon its lower end, the latter being engaged by a pinion upon a shaft (not shown in the cut) which imparts motion to the whole. As the retort turns slowly over the fire on the grate *F* the coal drops from the upper chamber into the next one below, and so on until the coal, deprived of the richest and largest of its gaseous content, drops into the coke chamber. As the upper chamber of the retort is emptied, the measuring drum *M* delivers a fresh charge of coal from the hopper into the carbonizing vessel.

At the working temperature mentioned the result from a ton of coal carbonized would be about 6,000 cubic feet of a rich gas, a large quantity of tar and other vapors, and some very indifferent coke. In the ordinary process the tar vapors are, almost immediately upon their emergence from the retort, condensed in the hydraulic main; but in the process under description the tar—still in the shape of vapor, to which condition it cannot easily be restored, having been once condensed—is brought into the superheater *S* (or

a retort heated externally and loosely filled with brick laid in the well-known checker form), where it is converted into a rich gas. In this way alone it was believed that the product of gas per ton of coal would exceed any results previously obtained under the old and well-known methods of gas making; but the resultant coke, while yet in a red-hot state, was to be treated to a current of superheated steam, with the object not only of considerably augmenting the volume of gas made, but the latter volume, being non-luminous, would furnish a proper diluent of the otherwise too rich gas obtained from the tarry vapors. The quenched coke might be removed; but were it not desired to save it the usual and well-known method of "blasting," subsequently adding a trifle of oil to the gas thus made, could be followed. Provision for that purpose was plainly made, as reference to the drawing will prove.

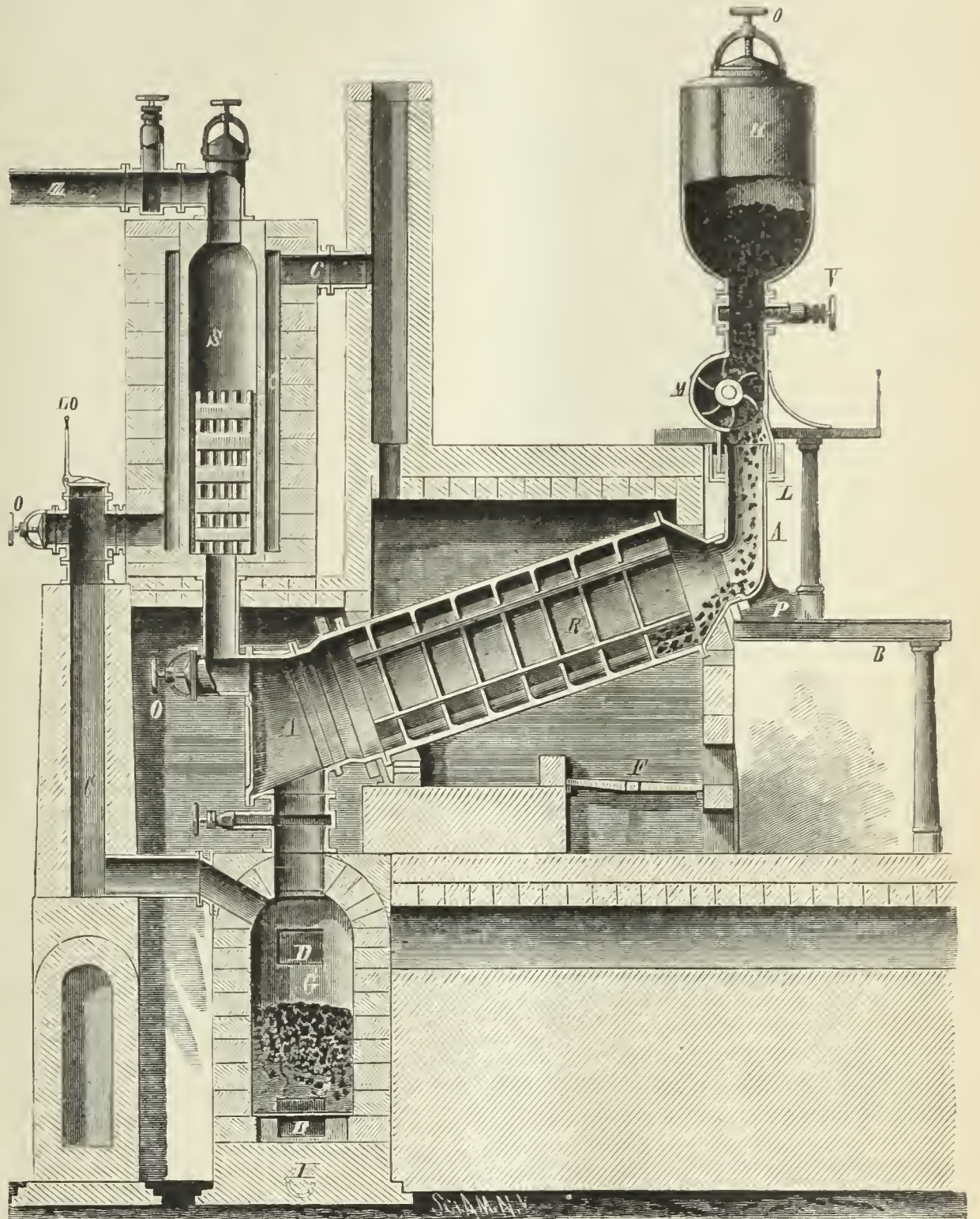

In practice it was found that iron retorts, when not subjected to a heat in excess of the one above described, had, after 15 months duty, preserved their integrity. Practically they were as good as new.

Several parties offered to furnish the means to build an apparatus, like the one described, on a large working scale; but, while the inventor would have risked his own money—if he had had any to risk—in a trial of the machine, he was not willing that others should, perhaps, sustain a loss. And so the project was laid aside—"maybe forever."

A portion of the machine would seem quite suitable for the purpose of making animal charcoal, or bone black, since certain objections to be met with in the manufacture of gas from coal are not met with when bones constitute the material to be used.

The indulgent reader may be disposed to admit that—on paper—the apparatus above described does not look altogether bad; but if the machine were built the verdict might not be so favorable. However, it may be safely said to be probably as good as most of these paper-patent processes—those which have never been tried save in the imaginations of their "discoverers."

Smale's Pneumatic Hydrometer.

Smale's pneumatic hydrometer, according to *Engineering*, is a handy instrument for measuring the depths of fluids. It is capable of being applied in many different situations. For instance, it may be used in a ship to ascertain the depth of water in the different compartments, and for this purpose it is placed in the chart room or in the engineer's cabin, and enables the officer to sound each part of the vessel in succession without leaving his post. In a brewery it will indicate to the manager the amount of water in the well, and in the various tuns throughout the building. In the latter case the dial may be marked in gallons if it be preferred. Many other situations will suggest themselves to the reader (the gas engineer will note at a glance how useful the instrument may be to him) in which an instrument

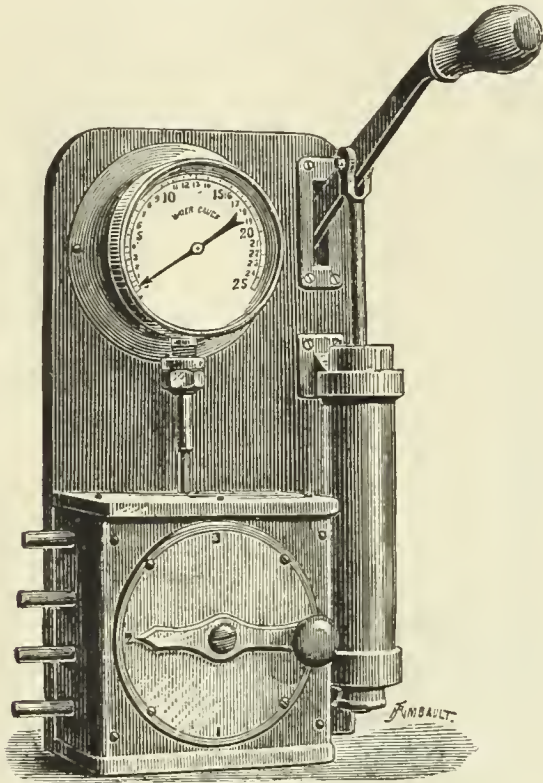

Pneumatic Hydrometer.

that will measure the depth of liquids at a distance, without involving the trouble of a visit to the spot, would be most convenient and economical of labor.

The principle on which the hydrometer acts is exceedingly simple. A pipe, open at the lower end, is placed in each tank or compartment to be measured. The other end of this pipe is led to an air compressing pump provided with a pressure gauge. The pump is worked and air forced into the pipe until the whole of the liquid is ejected from it, and the air escapes at the lower end. A reference to the gauge shows the pressure required to effect this, and this amount may be readily converted from pounds per square inch into the equivalent head of water. Or better still, the gauge may be marked in feet of the liquid which is to be measured.

The above illustration shows the instrument as constructed for sounding four vessels or compartments. The four pipes lead to a four-way cock, by which any one may be placed in connection with the pump and the pressure gauge. The manufacturers are Messrs. W. Reid & Co., 45 Fenchurch street, London, England.

SPECIAL ENGLISH CORRESPONDENCE.

COMMUNICATED BY NORTON H. HUMPHRYS.

SALISBURY, Feb. 10, 1887.

Temperature and Consumption of Gas.—Curious Flames.—The Foulis Gas Fire.—The Hefner-Alteneck Photometrical Standard.—Gas Business During the Second Half of 1886.—The London Gas Companies.

A recent issue of the *Journal of Gas Lighting* contains two diagrams, prepared by Mr. Frank Livesey, Chief Engineer to the South Metropolitan Gas Company, illustrative of the effect of atmospheric temperature on the gas consumption in his district for the years 1884 and 1885 respectively. The variations in the rate of consumption, after allowing for influences such as the rate of permanent increase, the effect of holiday times, etc., show a marked sympathy with the variations of the thermometer. As the thermometer falls the consumption rises, and *vice versa*; and the conclusion arrived at is "that the temperature is the principal agent in the production of variations in the gas consumption, as compared with that at the corresponding period of previous years." There are no special features about the South Metropolitan district which prevent the diagrams from being a fair representation of the results obtaining generally in our large towns. As there is

no reason to suppose that the atmospheric temperature has any direct effect upon the period of daylight, the principal conclusion to be drawn from Mr. Livesey's interesting diagrams is that gas is used to a considerable extent for warming purposes.

Mr. Thos. Fletcher, of Warrington, has lately been lecturing upon "Curious Flames," illustrating his remarks with experiments partaking of a popular science character. He first shows his reasons for believing that, contrary to general opinion, a large flame is really an evidence of waste. A boiler with the flues filled with flame does not give nearly such good practical results as when only a very small flame, barely visible over the bridge of the furnace, is obtaining. The gist of his interesting experiments is that a large flame means either an insufficient or an improperly arranged air supply; the result of which, in the case of a boiler is that large quantities of heat are wasted by dilution with an excess of air, which passes uselessly up the chimney, taking large quantities of heat away with it, and, therefore, leaving a less quantity for practical utilization. Or in the case of a vessel being heated over a gas burner, large volumes of air are heated by the large flame, and considerable quantities of heat are thus wastefully diverted from the object which it is sought to effect. If suitable arrangements are made for mixing the combustible gas with something like the proper equivalent of air, which is shown by theory to be necessary for combustion, a much smaller, but very much more intense, flame is the result; and under these conditions much better results are obtained in practice than in the former case. With a combustion of two cubic feet of gas per minute Mr. Fletcher produces a great flame, 8 inches in diameter by 18 inches high, and he proves, by experiment, that it is a mere shell or envelope, the interior of which is perfectly cold, and that it is almost useless for practical purposes. He then shows that by a rearrangement of the air supply, which in effect consists of mixing the gas before combustion with its proper equivalent of air, the flame is rendered "solid," whereby it is much reduced in bulk, but is much more manageable, and yields a much greater practical duty. And, finally, he proves that by careful adjustment of the air supply, and by placing a suitable solid body, heated to a sufficient temperature, in the path of the mixture, perfect combustion can be secured without any visible flame at all; and that these conditions secure the greatest possible amount of heat from the combustion of a given quantity of gas. His experiments are extremely interesting to all concerned in the practical application of heat for any purpose.

Mr. Wm. Foulis, Engineer to the Glasgow Corporation, and President of the Gas Institute, has lately introduced a new gas fire, applicable either to asbestos lumps or fiber. Instead of placing the burner immediately below the material that is to be rendered incandescent, so that the flame plays upon, and the act of combustion goes in actual contact with the same, he fixes it several inches below, and a curved channel, formed by blocks of fireclay, leads up to the material. By this means the flame is not only protected from draught, but combustion takes place without any cooling influences, thus securing the development of the highest possible initial temperature. The burner arrangement comprises a number of finger Bunsen burners, each fitted with a separate tap, so that any number between one and the whole may be in use according to the quantity of heat desired. The products of combustion descend at the back of the slab and pass off to the flue or chimney near the floor line; and there is an arrangement by which air, brought in from outside if preferred, is made to pass through the body of the stove, taking up heat as it travels, and escapes in a warm condition at the top.

Several members of the German Association of Gas and Water Engineers have been making practical tests with the Hefner-Alteneck amyl-acetate lamp as a substitute for the time-honored "candle" in photometrical experiments, and the results are in the main favorable to the appliance. This lamp certainly possesses the advantage of simplicity, as it merely consists of a reservoir for containing the fluid, a German silver tube of a given thickness and diameter to contain the wick, and two horizontal wires or pointers attached to a light frame for adjusting the height of the flame. No special care is necessary as to the wick, the principle of the apparatus consisting in the assumption that when the flame is adjusted at the proper height the light is constant. It is claimed that a flame about 40 mm. in height will give a light equal to the English standard sperm candle. This arrangement is so portable, simple and cheap that it is to be hoped that the successful results already recorded will be substantiated by further experience. It appears, however, that some skill is necessary in the manipulation of the lamp; for while some observers have experienced uniform success with it, others make various complaints. They say that the flame is very easily affected by draughts, that it is liable to yield a disagreeable odor, and in one case the fluid seems to have been impure. Of course, the main point is the possibility of relying upon the amyl-acetate as being always of constant quality and homogeneous in composition, so as not to vary after several hours' use in the lamp. It is claimed that the method by which it is produced is such as to enable this to be guaranteed. At the last meeting of the Association the experimenters compared notes, and their results are sufficiently encouraging to

warrant the expectation that the Hefner-Alteneck lamp will prove a useful appliance for gas engineers, even if it is not raised to the dignity of a standard. It requires no elaborate preparation, being ready for use in a minute or two at any time, and it is said that when the flame is once properly established, an unvarying light may be maintained for many hours. One advantage of the lamp is that it can readily be attached to one end of a scale beam, as is usual with the candles, and the rate of consumption accurately ascertained.

With the opening of February comes the usual half-yearly budget of reports from various gas undertakings, as to the working during the six months ended Dec. 31, 1886. The weather during that period was milder than usual, and this has had some influence on the gas consumption, an effect that would have been much more marked but for the spurt of genuine winter weather that set in just before Christmas. As it is, however, the general experience is that the usual rate of increase in the consumption of gas has not been maintained. The low state of the residuals market was another adverse circumstance, intensified by the fact that the long run of mild weather diminished the demand for coke. On the other side, coals and iron have been cheap, so that in most cases a fairly satisfactory balance sheet has been realized, and the usual dividends can be paid without increasing the price of gas. But some companies have to dip pretty deeply into the accumulated funds in order to maintain this state of things. The Corporation of Birmingham and a few other undertakings have been obliged to resort to an increase of price, a step which, it is needless to say, is almost equivalent to disturbing a hornet's nest. Hopeful opinions are generally expressed as to the future. There are signs that the depression in trade, which has now existed for some time, is moving, and it is to be hoped that it will give way to a prosperous state of affairs, in which gas undertakings would participate in common with other industries.

The report made by the directors of the Gas Light and Coke Company of London sets forth that there is a balance available for dividend of £383,927; but this includes an amount of £119,462 carried on from the last account, so the actual earnings during the six months in question are £264,465. It is proposed to pay a dividend on the ordinary stock after the rate of 12 per cent. per annum, which will absorb £328,076, or £63,611 more than has been earned. The effect of this step will be to reduce the balance of undivided profit to £55,851, or more than half. Owing to the causes above named the receipts for gas remain about the same as in the corresponding period of last year, but the residuals have fallen from £282,493 to £244,840, a drop of £37,653. It will be observed that the loss on the head of residuals is not sufficient to account for the reduction in profits, which is actually nearly £80,000 less than during the corresponding period of 1885. The report of Mr. Harris, the distribution engineer, certifies that the gas mains belonging to the Company are about 1,800 miles in length, that the number of meters in use by the consumers is about 201,000, and that 5,688 gas stoves are out on hire. The directors speak hopefully of the increased day consumption. Unless things improve with them a rise in the price of gas appears imminent.

The South Metropolitan Gas Company has been more fortunate. They only require to draw upon their balance of undivided profit to the unimportant extent of £2,686, in order to pay their usual dividend of 13 per cent. A small increase in the consumption of gas, 4½ per cent., has been experienced, and it should be observed that while this is small as compared with the usual rate of increase experienced by this Company, it would be considered extremely satisfactory by many boards of directors. They have, like their neighbors on the other side of the Thames, experienced a loss on residuals; 27 per cent. of the total production of tar has been used as fuel, and as such is worth 1½ d. per gallon, whereas it realizes only ½ d. at present selling prices. But for the reduced value of residuals there would have been a surplus on the half year's working, notwithstanding the reduction in the price of gas which was made at the beginning of the year.

ITEMS OF INTEREST FROM VARIOUS LOCALITIES.

THEY VOTED FOR ELECTRICITY.—At a public meeting of the electors of the town of Hillsdale, Ohio, recently held in the local Court House, the voters balloted upon the question as to whether gas or electricity should be used for public lighting during the coming year. A count of the votes showed that 288 favored electricity, while 35 adhered to gas. The matter of a choice of electric systems was left to the decision of the Town Council.

GAS WORKS FOR DODGE CITY, KANSAS.—Several prominent men of Dodge City have subscribed \$50,000 for the erection of a gas plant in that locality. Work on the same is to be commenced forthwith. Dodge City is the capital seat of Ford county; is on the Arkansas river, and the main line of the Atchison, Topeka and Santa Fe Railroad, at a point 302 miles west-south-west of Topeka. Population about 5,000.

PRESIDENT MORTON ON MEASUREMENT OF ARC LIGHTS.—President Henry Morton, of the Stevens Institute of Technology, Hoboken, N. J.—and probably a more expert and painstaking scientist does not live to-day—recently visited Bridgeport, Conn., at the invitation of a committee of the Aldermanic Board of that city, for the purpose of testing the actual candle power of the arc lights there maintained at public expense. In his official report to the Board the experimenter said: "The average candle power of the 15 lights, when measured, was about 1,100 candles, or in exact figures, 1,111 candles. As compared with the electric lights used for lighting the streets of our cities generally this is a very good showing. I had occasion some time since to measure the light of a number of the lamps used in the streets of New York city, and found that the best of them only reached 800 candles. It has been customary ever since the first introduction of electric lighting for the electric companies to call their ordinary street lights '2,000-candle power lights,' though they have not possessed any such actual efficiency. If, therefore, you were to hold your electric light company to the wording of their contract, they might reasonably claim that the term '2,000-candle power' had become a technical expression, meaning only a light of the usual efficiency from 500 to 1,000 actual candle power by direct measurement." No wonder the experimenter had reason for congratulating the Bridgeport City Fathers on the efficacy of their arc illumination; but we think a different order of affairs would be disclosed were the President invited to test the half-ares supplied in Brooklyn. In connection with this matter of the actual candle power of arc lights we think it timely to reproduce the figures furnished by the Committee of the Franklin Institute in regard to their examination of the arc lights displayed at the Institute's Electrical Exhibition, held in the fall of 1884. The Committee thus reported:

Name of Lamp.	Candle Power.		Horse Power, per lamp.
	Horizontal.	Angle, 45°.	
Arago.....	273	583	.824
Ball.....	223	485	.432
Brush (1,200).....	180	613	.466
Brush (2,000).....	389	1,373	.785
Diehl.....	323	830	.754
Richter.....	313	894	.812
Van de Poele.....	333	1,162	.817
Western.....	263	266	.617

The lamps of the Thomson-Houston and United States Companies were not exhibited. Ten observations of each lamp were made (the above represents an average) at each of the several altitudes measured, and the variation in the intensity of each lamp during the test, at any altitude, was found to be very great. A more extended mention of this subject will be found in the issue of JOURNAL for July 2d, 1885, Vol. 43, p. 2.

CAPITAL STOCK INCREASED.—In our last we announced the formation of a Company to build gas works at Castleton, Staten Island. The capital stock was originally fixed at \$50,000, but that amount has since been doubled.

PREPARING FOR THE NEAR FUTURE.—The proprietors of the St. Paul (Minn.) Gas Light Company have purchased 4½ acres of land, in the tract known as "Hewitt's Addition," at a cost of \$10,000, with a view to securing an eligible basis for locating a future works. The purchase was a wise one, for at the figure named, even if a gas plant will never be put on it, the site cannot fail of being a profitable investment in a speculative point of view. We understand that the St. Paul Company will shortly make provision for the supply of the suburban districts bounded by Hamline, Merriam Park, and Macalester.

HURON WANTS A GAS WORKS.—A petition was presented to the City Council of Huron (Dakota Territory), on Feb. 7th, by parties who asked a perpetual charter for a gas company for that place. The petitioners sought the Council to agree to maintain 50 public lights, and to pay therefor at the rate of \$35 each per annum. The matter was to have been settled either one way or another on Feb. 21st, but we have not been apprised of the result.

SORELY BEREAVED.—We deeply regret to be called upon to announce the death of Elizabeth Lord Chase, late the wife of Mr. John M. Hill, so well known to the Eastern fraternity in his capacity of Agent and Treasurer of the Concord (N. H.) Gas Light Company. The sad event occurred on Feb. 5, and the funeral services were celebrated on the following Monday. Deceased was born in Boston, Mass., on July 3, 1825, and became the wife of Mr. Hill on Nov. 15, 1843. A bright woman, loving wife, and noble mother, deceased bequeathes to her bereaved ones an example of perseverance to the end.

THE TEST WAS ILLEGALLY MADE.—Some time since an official inspection of the gas supplied in West Washington (D. C.) was made at an hour different from that prescribed by the law, and the result of the examination disclosed the fact that the gas was deficient in illuminating power. Thereupon

the authorities attempted to collect the fine imposed for such delinquency by the statute, but the Company demurred by asserting that the test was illegal, since the law directed the inspector to make his tests between the hours of 5 and 11 P.M. On the trial of the case it was proved that the inspection was made at 10 A.M., and Justice Cox thereupon dismissed the proceedings.

TO LAST FOR TWENTY YEARS.—The agreement betwixt the United Gas Improvement Company and the old Yonkers (N. Y.) Gas Light Company is to last for 20 years from 1st of Jan., 1887.

GAS LEGISLATION IN CALIFORNIA.—A bill for the regulation of gas companies in the Golden State was recently introduced in the California Assembly by Representative Lewis. It provides that no company shall collect any moneys for gas supplied unless the meter through which it was measured shall have been proved by the State Inspector of Gas Meters. Whenever any company, incorporated under the laws of the State, combines with any other company to raise or fix the price of gas, or leases its works or property to another gas company, whether to the trustees or otherwise, it shall lose all rights gained by incorporation, and its property of every kind shall escheat to the State. The company so leasing the works or plant of any other gas company for the purpose of controlling the price or the quality of gas manufactured shall suffer in like manner. All meetings of directors and stockholders of any gas corporation incorporated in the State (also all books, etc.) shall be open to the inspection of the Attorney-General, or of his deputy appointed for that purpose. Somewhat in the nature of a steel-clad proposition!

KILLED BY THE CURRENT.—Early last month a youth named John Brandt attended a performance at the Peoples Theater, Cleveland, Ohio. The lad, who was in the gallery, coveted a seat reserved for ladies, and in attempting to secure it attracted the attention of one of the ushers. Brandt, hoping to allay the latter's suspicions, crouched close to the wall, uttered a groan, and dropped to the floor. The unfortunate youth had come in contact with the wires leading to an arc light in the dome of the theater, and these having been improperly insulated, was killed. Coroner West and a jury certify to the cause of Brandt's murder—for it was nothing else.

A BIG ELECTRIC LIGHTING COMPANY.—The California Electric, Gas Light, and Fuel Company was incorporated in San Francisco on Feb. 11. W. D. Cluff, J. D. Boyer, and J. Dewing, of Alameda, H. McGovern, of Chicago, Ill., and B. B. Duncan, of San Francisco, are named as the incorporators. The Company is capitalized in \$3,000,000, and it is said that it will supply electric light in Oakland, Sacramento, Los Angeles, San Jose, Stockton, and San Francisco. Perhaps the "Gas Light and Fuel" portion of the title is intended as a saving clause in case electricity will not be eagerly seized upon by the residents of the localities named in the prospectus. At any rate, the stock of the original San Francisco Electric Company can be bought quite cheap at the present time.

ANOTHER GOLDEN STATE COMPANY.—The California Gas Fixture Company has been incorporated. Object, to manufacture and sell gas fixtures, lamps, and oils. Capital, \$100,000. Directors, J. Simonson, F. W. Farrar, R. P. Merrillion, G. F. Duffey, and E. J. Duffey.

SETTLING THE LIGHTING QUESTION AT XENIA, OHIO.—The Xenia City Council has accepted the proposition made by the local gas company. Under the new arrangement the gas company agrees to supply gas to the city and to the citizens at the uniform rate of \$2 per thousand cubic feet provided payments are made on or before the tenth day after presentation of bills. All new street gas lamps erected are to be supplied with gas at the rate of \$26 per post per annum.

ANNUAL MEETING AT NANTUCKET, MASS.—The annual meeting of the Nantucket Gas Light Company resulted in the choice of the following Board of Directors: Messrs. D. C. Baxter, E. H. Allen, W. F. Codd, A. T. Mowry, and C. Parker. At the meeting for organization Mr. A. T. Mowry was elected President, and Mr. A. M. Myrick Secretary and Treasurer. The financial showing made by the Company in the past year was quite satisfactory to the shareholders. The Company was organized in 1854; is capitalized in \$36,000; average price received for gas, \$2.82 per thousand; works are calculated for a maximum per diem production of 28,000 cubic feet; total main mileage, 4½ miles; total number of consumers' meters in use, 197; public lamps maintained, 71; average candle power of gas supplied to consumers in past year, 18.30; dividend payments, 6 per cent.

WILL THEY SUCCEED?—We understand that State Senator McWhorter, of Delaware, recently introduced a bill in the Delaware Legislature which seeks to incorporate the Delaware Light, Fuel and Power Company. The parties named comprise Messrs. W. L. Elkins, Jr., of Phila., Pa., and Messrs. J. M. Dunn, J. P. Postles, G. W. Bright, E. Moore, Jr., and Jno. Peoples, of

Wilmington, Del. The capital stock is placed at \$100,000; but power is sought to subsequently increase the amount to \$1,000,000. They propose to furnish "heat, light and power from gas, steam, electricity and other substances"—scientists will be glad to know that the applicants have thus settled the doubt in regard to what electricity really is; for "substances" are all so easily grasped. In order that the "substances" may be made available the petitioners ask for "full power and authority to enter upon streets, roads, bridges, tenements, etc., all over the State." This sweeping demand reminds us of the answer returned by the Delaware Legislature to a somewhat similar request made upon it by agents of the Standard Oil Company in 1881. The reply in effect was, "You may want the earth; but you can't get Delaware." If history repeats itself a like rejoinder would seem to be now in order.

AND YET ANOTHER.—Representative Ware has introduced a bill whose sponsors seek the right to charter the Citizens Gas and Fuel Company to operate in Wilmington, Delaware. The interested ones are Messrs. A. D. Warner, J. Bailey, P. Lea, T. B. Smith, W. G. Pennypacker, G. G. Lobdell, C. N. Trump, A. G. Wilson, J. H. Hoffecker, S. N. Trump, and L. Smith. These gentlemen are more modest than the others, for they simply wish to probe Brother Curley's territory. It is unlikely, however, that either set of speculators will obtain the desired grant.

AN INTERIM DIVIDEND OF FOUR PER CENT.—The Quebec (Can.) Gas Light Company has declared a dividend of 4 per cent., payable from and after first instant, out of the earnings of the past six months, ended Feb. 1st.

FLATBUSH (L. I.) STREET LIGHTING CONTRACT.—At a recent meeting of the Flatbush town authorities a contract to run for one year from Feb. 14th last for maintaining 330 public gas lamps was entered into by the Flatbush Gas Company and the borough. The price agreed upon was \$31 per post per annum, a decrease of \$2 from the rate charged in 1886.

THE WORCESTER HEARING.—The newspaper warfare against the Worcester, Mass., Gas Light Company having been transferred to the province of the Massachusetts Gas Commission, and with the usual amount of "indignant consumer" testimony being poured into the ears of the Commission, we must say that the latter are deserving of sincere commiseration. However, it does not seem that the Worcester *Telegram* agitators have scored much of a victory as yet, if we except the fact that the Worcester Company's main system seems hardly adequate to the proper supply of the district. As previously noted in the *JOURNAL*, the Company, in any event, intended to remedy that defect with the coming season. In fact its plans in that direction were prepared some time ago.

GAS ENGINES IN FASHION AT ST. PAUL, MINN.—Quite a number (at least 30) of gas engines are in use in St. Paul, and when the \$1.50 gas rate (it goes into effect on 1st prox.) becomes operative the employment of these motors will be greatly extended. We give a few examples of the actual expense that attended the operation of gas motors in St. Paul during the last year, when, it should be borne in mind, \$2 per thousand was charged:

Operators.	Horse Power.	Business.	Cost for Gas.	Repairs, oil, etc.
R. L. Hardenhigh.....	7	Running elevator.	\$171.20	\$25
Volks Zeitung Co.....	10	Publishers.....	392.80	32
H. Schnell & Co.....	2	Grinders.....	103.20	None.
I. L. Herotz.....	4	Cigar boxes.....	151.60	"

THE AMERICAN ELECTRIC MANUFACTURING COMPANY.—Gas men throughout the country must often wonder how it is that the American Electric Manufacturing Company manages to secure such a large number of "reading notices" in the various newspapers. Whoever has charge of that particular branch of Mr. Edwards H. Goff's business is an adept, and we surmise that Mr. Shanks, formerly of the New York *Daily Tribune*, could let us into the secret. The latter gentleman compiles what is now known as a "syndicate letter," which purports to give to those newspapers forming the "syndicate" the current gossip of the metropolis. Say, for instance, 20 newspapers, in as many different cities and towns, club together and agree to contribute \$5 apiece each week in return for which they receive a letter from Mr. Shanks, who purports to place before them, in readable, gossipy style, the current week's news of New York city. Of course, the arrangement is a fair one, and results, no doubt, in benefit to Mr. Shanks and to the syndicate; but somehow or another the syndicate letters rarely fail to contain some direct reference to the American Electric Manufacturing Company, and to the "life's work" of Edwards H. Goff, its President. Our Eastern and Middle States' readers must also have noticed that Edwards H. Goff receives a good deal of notice in the pages of the New York *Daily Tribune*, and it may be considered certain that the *Tribune* folks are in the habit of exacting and receiving pay for the performance of advertising work, no matter whether the same be rendered in the shape of "reading notices" or not. Even at the

risk of devoting too much space (which cannot be purchased by anybody) to the American Electric, etc., advertising bureau, we feel that we ought to reproduce the following despatch, dated Boston, Feb. 17th, as it appeared in the columns of the New York *Daily Star*: "It is not generally known that the managers of the New England gas companies have been quietly holding a convention here for the purpose of considering the proposition of the American Electric Manufacturing Company of combining the gas and electric light interests. The result is that every New England manager who appeared in the convention indorsed the system of the American Electric Manufacturing Company, of New York, of which Edwards H. Goff is president, and will hereafter work in connection with that system of electric lighting." Now, this will be news to those who attended the 17th annual meeting of the New England Association of Gas Engineers, with the sole and simple object of comparing notes as to the progress gained by them in the gas making business during the last year. All things considered, it might be well for the American Electric, etc., if its advertising bureau were "reformed" to a slight extent.

TO PUSH THE EXHAUSTER BRANCH OF THEIR BUSINESS—The Messrs. Connelly have determined to bring their steam-jet exhauster specialty prominently to the attention of the fraternity. Their card on the subject will be found in the advertising pages of our present issue.

ANNUAL ELECTION, AUGUSTA, GA.—At the stockholders' meeting (Augusta Gas Light Company) the following officers were elected: President, G. T. Barnes; Secretary, H. B. Adam; Supt., G. S. Hookey; Directors: Messrs. G. T. Barnes, E. R. Schneider, T. G. Barrett, P. Walsh and P. H. Langdon. The annual reports afford a most satisfactory showing.

ANNUAL ELECTION, CONSUMERS GAS COMPANY, CHICAGO, ILLS.—This corporation has chosen the following officers: Directors, Messrs. C. E. Judson, W. H. Ryder, C. R. Cummings, S. A. Kent, W. S. Reyburn, J. E. Addickes, E. Washburn, C. T. Yerkes, and J. B. Cohrs. President, C. E. Judson; Vice-President, W. H. Reyburn; Sec. and Treas., F. P. Addickes.

BIDS FOR PUBLIC LIGHTING, SCRANTON, PA.—The Scranton and Hyde Park Gas and Water Companies offer to light the public lamps at the rate of \$1.50 per post per month. One electric company offered to light with 2,000-candle power arcs on the basis of 30 cents per light per night, while another company would not undertake the task for less than 40 cents. The Sun Vapor Light Company (gasoline) wanted \$19.50 per post per annum, while the Pennsylvania Globe (naphtha) Company would be content with \$18.50.

TO PROVIDE GREATER SECURITY.—It is understood that Secretary Balch, of the New York State Board of Health, has drafted a bill, for the consideration of the present legislative convocation, which is intended to provide greater security to gas consumers. It was suggested by the late fatal Troy experience. It makes stringent regulations in the matter of piping, and requires that all gas intended for public use shall possess an odor sufficiently pungent to make its presence manifest.

THE MALDEN COMPANY'S RECORD.—During the year ended December 31, the Malden and Melrose (Mass.) Gas Light Company manufactured 25,716,700 cubic feet of gas, of which 19,085,700 cubic feet were sold by meter, and 2,964,900 cubic feet were consumed in the public lamps, leaving the unaccounted-for portion at something like 3½ millions. The works have a capacity of 200,000 cubic feet per day. During the year 2,218 tons of coal were carbonized, and 6,840 gallons of naphtha were absorbed.

THE FRACKELTON PORTABLE GAS KILN.—Those managers of gas works, especially in the larger cities, who have not seen this kiln ought to make inquiry regarding it. The craze for "decorative art work," in the shape of amateur attempts at painting china ware, rages rather fiercely within the frame of the girl of the period, and gas men ought to take advantage of the whim. It will help their day consumption, for the aforesaid girl, once she knows where to secure the Frackelton article, or one equally as good as it, will not be satisfied with any other apparatus for "fixing" the creations of her art. Mr. Frackelton's address is 119 Wisconsin street, Milwaukee, Wis., and we cheerfully give him this notice, although the gentleman never thought it worth while to ask for it.

IT MIGHT HAVE BEEN WORSE.—Some excitement was caused in Hollidaysburg Pa., on the afternoon on February 15, when it was thought the local gas works were about to be consumed by fire. They still stand, and the damage was not in excess of \$50.

FIX UP THE PIPES.—Judging from recent reports the gas piping in the Capitol Building at Albany, N. Y., must be sadly out of order, for we are told that several departments were closed in the structure, on date of Feb-

ruary 18, because of the prevalent odor of gas in the State's several-million-dollar building! Perhaps the cause was slightly exaggerated by those interested in the electric lighting business; for these promoters now light a portion of the premises, and possibly would like to secure the balance.

TYRONE, PA., TO BE LIGHTED BY ELECTRICITY.—The Tyrone Council has decreed that Tyrone's streets are to be electrically illuminated at night. The Home Electric Light Company's proposition, to furnish 80 twenty-five candle-power incandescent lights, to burn all night and every night in the year, at the rate of \$16.66 each per annum, has been accepted; but the Home promoters also agree to furnish 18 sixteen-candle power lamps (to be divided between the city fire engine house and the Council meeting room) to the municipality free of charge. It would seem that another contract of the kind would be apt to hurry the Home's property to the care of the Sheriff.

BROTHER ALEXANDER'S INVENTION.—Most gas makers in this country are no doubt duly impressed of the fact that Miss Margaret Mather is an accomplished actress; but we incline to the belief that the fraternity will not concede her brother's transcendent abilities as a gas engineer. The family cognomen is Finlayson, and Miss Mather, of course, assumes her proper appellation when not engaged in displaying her talents on the stage; but, at any rate, in order to show why we are doubtful about her brother Alexander's claim to gaseous distinction, we submit the following concerning an "invention" recently brought to light, at Detroit, Mich, by the aforesaid gentleman. Over an ordinary stove, after the fashion of placing a pot, he sets an upright retort of "convenient size," said retort, having been charged with wood, is securely sealed prior to its location over the "kitchen fire." As the gas is distilled it passes "over the back of the stove" to a washer handily situated, thence to a purifier box, "fitted with three trays of lime"—it should be explained that the purifier is superimposed on the "washer," the latter being connected with the former by a "small hole"—then through another hole into a holder, from whence it passes into the house pipes, on to the jets, and "there is light." Perhaps, if Sister Margaret seeks to have some realistic stage effects—such as thunder, sulphurous smell, and debris—she had better introduce Brother Alexander's invention to the notice of her stage manager.

NEW HOLDER FOR THE SPRINGFIELD GAS LIGHT COMPANY.—During the present season The Springfield (Mass.) Company will construct a large holder. Negotiations for the purchase of the ground whereon to locate it are now in progress.

Correspondence

[The JOURNAL is not responsible for the opinions expressed by correspondents.]

Mr. Egner in Further Explanation of that "Chapter."

St. Louis, Mo., Feb. 21, 1887.

To the Editor AMERICAN GAS LIGHT JOURNAL:

With your permission permit me to say to "A. S.," whose latest comment appears on page 109 of current volume, that the station meter, photometer, and even the operator who recorded the meter statements and made the photometrical observations, which results were reported in the tables whose veracity is questioned by "A. S.," are the identical ones bequeathed to the Laclede works by Mr. Farmer. In most instances the very workmen about the plant can be traced to Mr. Farmer, although now "A. S." quotes Mr. Farmer's rule as authority for proving that I have erred. In fact the greatest difference perceivable in these works now as compared with the period of Mr. Farmer's rule is that the system of carbonizing has changed. For instance, in the last year in which the gentleman whose "rule" is quoted (probably to confound the writer) had charge of the works of the Laclede Company the average make per mouthpiece per diem equaled 6,201 cubic feet—average for the entire year is referred to—of 16.15-candle power gas; whilst in the year after the writer took charge of the plant the average daily make per mouthpiece was 9,066 cubic feet of 19.74-candle gas. This latter result, let me repeat, was secured by the use of same meter and photometer, by the same observer, the retorts being worked by almost the same men—the benches being similar except in the matter of slight alterations made by the writer—as those used and employed by that deservedly eminent gas engineer whose "rule" "A. S." quotes against my statements. My working system differed from Mr. Farmer's, and the foregoing is merely mentioned by the writer to show that the "world has not stood still" since "A. S." learned the principles of Farmer's theorem. The writer is not an "old gas man," but perhaps even "A. S." does not know it all. Evidently (to me at least) the latter could learn something by coming here. If he can pay me a visit it might serve him well to thus study up how my results were obtained. It would give me pleasure to show him on the premises how I secured them.

Yours truly,

FREDERIC EGNER,

The Market for Gas Securities.

Nothing of importance can be mentioned in connection with either the local or Brooklyn gas share market. Values have been fairly well maintained, but real transactions were few and far between. The sensation in out-of-town circles is furnished in the circular sent out by the managers of the old Chicago Gas Light Company, and reference there-to will be found in our editorial pages. They ought not to experience much trouble in securing purchasers willing to pay a higher price than that which it is urged should be accepted as an equivalent for the value of the property. The works advertised for sale in present issue ought also to be quickly snapped up, for it is a good property. We understand that a one-third interest in the Rock (Ills.) Gas Company can be purchased. Baltimore stocks are stronger, and possibly the Baltimore gas war will soon be ended. It is about time that Baltimore gas shareholders were allowed to enjoy their terrapin in peace.

SUPERINTENDENT'S POSITION DESIRED.

By a practical gasfitter and competent bookkeeper, who has had entire management of coal and water gas plants. Satisfactory references furnished. Address
665-3 "B.," care this Office.

ENGAGEMENT DESIRED

As Superintendent or Foreman of Coal or Water Gas Works.

Has had years of experience in manufacture or distribution of gas and construction of works. Address
665-1 "E.," care this Journal.

SUPERINTENDENT'S POSITION WANTED

By a practical manager of coal and oil gas works, of 22 years graduation in all the departments—viz., distribution, manufacture, and secretary's duties. Also has a partial knowledge of electric lighting. Satisfactory references given. Address
665-1f R. HORTON, care this Office.

Superintendent's Position Desired

By a practical man of twenty-five years' experience in the manufacture and distribution of coal and water gas. Satisfactory references given. Address
646-1f "ENGINEER," care this Office.

SITUATION WANTED

By a Practical Gas Engineer.

For 18 years in charge of very successful operations of a coal gas works. Best of references given. Address
"F. B.," care this Journal.

**GAS WORKS FOR SALE.
A RARE CHANCE.**

The owner will dispose of the controlling interest in a gas works in a growing Western city, on account of declining health and inability to attend to the business. For particulars address
665-6 P. O. Box 825, Appleton, Wis.

**FOR SALE,
Two Sinuous Friction Condensers,**

Each 1 ft. 3 in. wide by 11 ft. 3 in. long, and 18 ft. high, of sufficient capacity for 225,000 cu. ft. per day. Apply to
665-12 PETER COFFEY, Supt. Gas Co., Peoria, Ill.

FOR SALE,

Ten No. 2 Siemens Regenerative Gas Lamps,

With Factory Fixtures and Reflectors complete and in order. Only used three or four months. Will be sold cheap.
DANVILLE NAIL AND MFG. CO.,
Danville, Pa.

ENGLISH

"Journal of Gas Lighting."

Issued weekly. New volume commences Jan. 1, 1887. Price, \$7 per annum. Subscriptions taken by
CHARLES NETTLETON, Agent for U. S.,
NO. 115 BROADWAY, N. Y. CITY.

Ferric Oxide for Gas Purification.

Ferric Oxide, as ground, screened, and prepared by me for purifying purposes, has now been in use for several years by many of the gas works throughout the country, including Detroit, Chicago, Milwaukee, East Saginaw, Burlington (Iowa), Ann Arbor, etc. It has proved, as I believe, the **Most Effective and Economical Agent** now in use. I am prepared to furnish the Oxide by the 100 lbs. or in car load lots, and will be pleased to give price f.o.b. cars at Ann Arbor or at place of destination. Address

S. H. DOUGLAS, Prest. Ann Arbor (Mich.) Gas Light Co.

F. J. DAVIS & J. R. FARNUM,

TRUSTEES AND AGENTS FOR THE

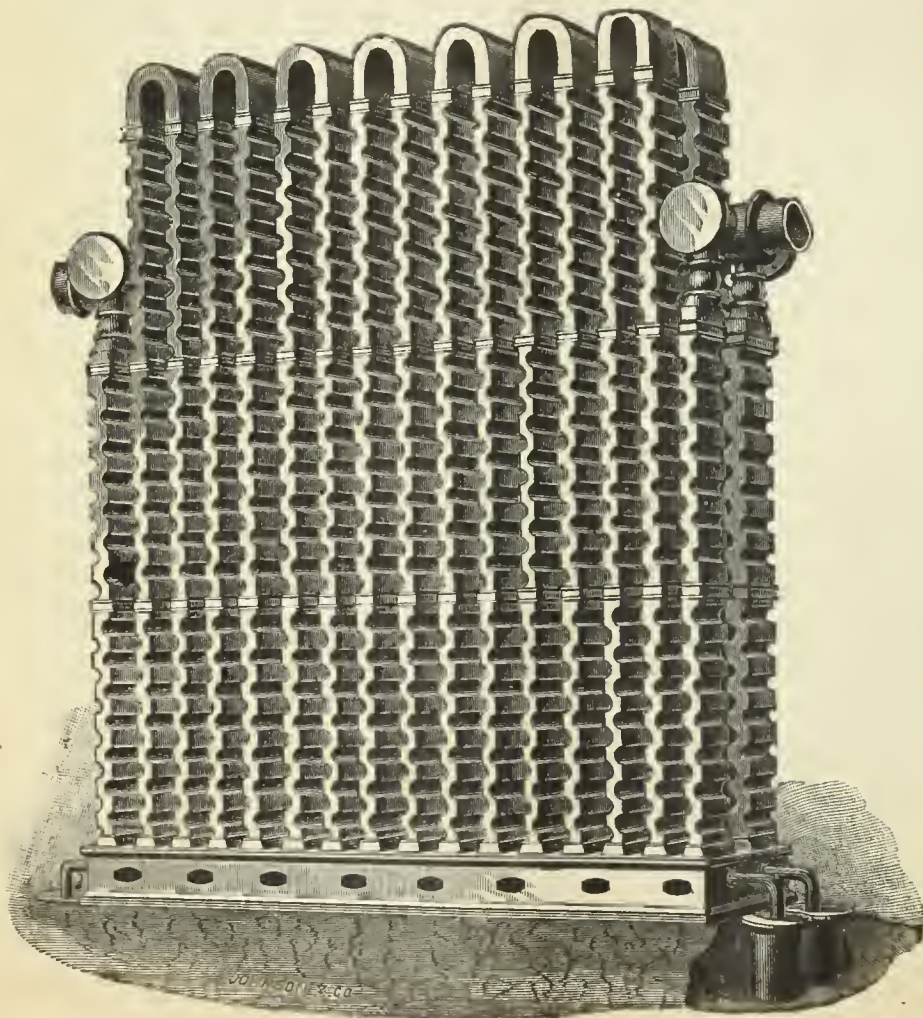
SINUOUS FRICTION CONDENSER.

We desire to draw the attention of the gas community to the merits of the **SINUOUS FRICTION CONDENSER**. Companies intending to introduce new condensers into their works will do well to confer with us and examine plans and estimates before contracting for any other pattern. The **FRICTION CONDENSER** is now in use at the gas works located in the following places:

Portland, Me.	Brookline, Mass.	Pawtucket, R. I.	Frederickton, N. B.
Newport, R. I.	Chelsea, Mass.	Jamaica Plain, Mass.	St. John, N. B.
Gloucester, Mass.	Woburn, Mass.	Attleboro, Mass.	Paterson, N. J.
Newton & Water- town, Mass.	Peoria, Ill.	Calais, Me.	Dover, N. H.
	Clinton, Mass.	Fall River, Mass.	Waltham, Mass., Nassau Works, Brooklyn, N. Y.

DAVIS & FARNUM MFG. CO.

MANUFACTURERS OF

Gas and Water Pipes,

AND

GAS AND WATER MACHINERY

OF THE MOST APPROVED PATTERN.

Also, Gasholders and Iron Roofing.

Orders from Gas and Water Companies promptly attended to.

WALTHAM, MASS.

Boston Office, Room 55, Mason Building, 70-Kilby Street.

Kloenne & Bredel Improved REGENERATIVE FURNACES

Self-Sealing Mouthpieces and Bridge Pipes,
RETORT HOUSES, WASHER-SCRUBBERS,
GASHOLDERS, AND GAS WORKS COMPLETE.

Our system of heating retorts by regenerative furnaces is the simplest, most economical, most durable, and cheapest of any in use. It is the only regenerative furnace used to any extent in Great Britain, where several thousand retorts are working at the present time. In Birmingham alone 952 retorts were erected, and they are giving the best satisfaction ever obtained from any regenerative furnaces. The great advantages our benches have over all others are the following:

The generator and regenerator are independent of each other, so that any contraction or expansion of one will not interfere with the other.

The superheating surface is greater than in any other furnace yet constructed. The regenerator is absolutely self-tightening, and cannot get out of order.

The thickness of material between the wastegases, secondary and primary air is only $1\frac{1}{4}$ inches, which increases the regenerative power from 100 to 500 per cent.

The generator is working absolutely cold, and therefore is not liable to any perceptible wear and tear.

The grate, having an enormous surface, allows the use of an inferior fuel, such as breeze, fine coke, or slack coal.

Clinkers are never formed. By an ingenious arrangement of mixing air and the steam produced by the cooling water all incombustible materials in the fuel are formed into soft ashes.

The waste gases go up through flues at 400° to

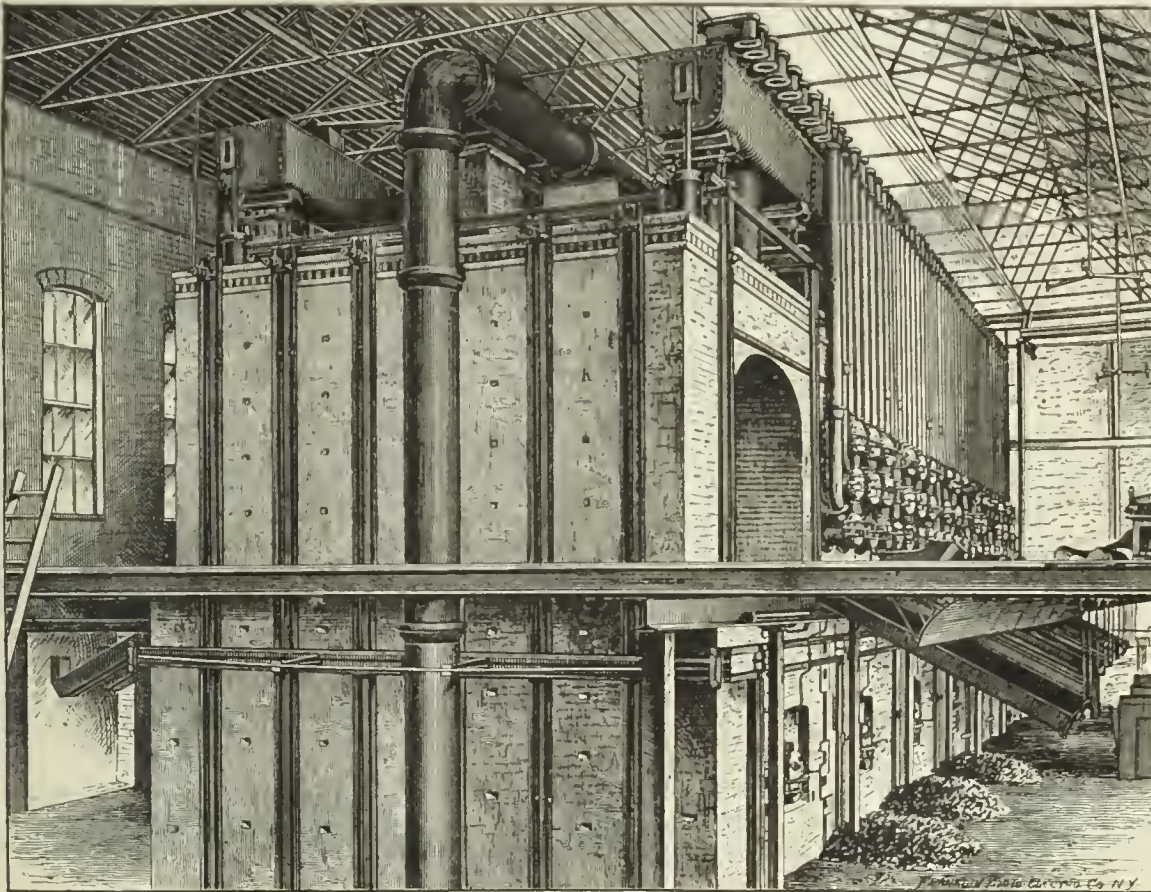

500° F. No large chimneys are required.

No cold air can enter; consequently no cracking of retorts.

The generator is inside of bench, thereby preventing any loss of heat; and stokers do not have to stand on a hot floor, as is the case where the generator projects outside of the bench.

In the past two years more than 500 retorts, with a capacity of five million cubic feet of gas per diem, have been erected in this country, and these are giving the best satisfaction, as the following testimonials will show.

We also construct half-regenerative benches, which will give the best results, and can be built in existing skeleton arches.

OFFICE OF THE NEWARK GAS LIGHT COMPANY, NEWARK, N. J., January 28, 1887.

MR. FREDERICK BREDEL, General Agent Kloenne Regenerative Furnace:

Dear Sir—The Kloenne Furnaces erected by you have been in continuous use for more than a year, and continue to give us satisfactory results. We are carbonizing 1,800 pounds coal per retort in 24 hours, and the average fuel consumption for this much has been 16.8 pounds by volume of the coke produced, or 100 pounds coal have been carbonized by 11.25 pounds hot coke. We have not lost a retort yet, and I think that those in use will give us six months' more service.

Very truly,

[Signed] EUGENE VANDERPOOL.

ENGINEER'S OFFICE, MILWAUKEE GAS LIGHT COMPANY, MILWAUKEE, WIS., January 26, 1887.

FRED. BREDEL, C.E.: Dear Sir—Upon your request for a testimonial for publication, I am pleased to send you the following, as I consider it deserved for the way in which your contract was carried out with us. I would say to any in the profession that among all the plans of benches presented to me from which to select I chose the "Kloenne" for several reasons. I considered it perfect in principle, that at all times it would be under absolute control, and also that each block in the regeneration could be easily seen and repaired if necessary. Your work upon our benches was done as good as it possibly could have been by anyone, and such has been the opinion of the several visitors during the progress of the work and since its completion, without exception. We have been running the furnaces since Oct. 6, and as yet have observed no cracked or sagged retorts. Every part of the work appears as perfect as when set. Although the first month was used up in experimenting and learning how to run the furnaces, and since that time we have experienced very cold weather, yet we are selling 26 bushels of coke (40 lbs. per bushel) per net ton of coal used. The consumption of coke in the furnaces does not exceed 20 per cent. at the present season, and for the year I am sure will be materially less.

Yours truly,

[Signed] E. G. COWDERY.

OFFICE OF THE CHICAGO GAS LIGHT AND COKE COMPANY, CHICAGO, ILL., January 27, 1887.

FRED. BREDEL, Esq.: Dear Sir—We have had eight benches of nines with the Kloenne furnaces running continuously for 13 months. The results have averaged 9,000 cubic feet per mouthpiece in 24 hours, with a fuel consumption of 13 pounds coke per 100 pounds coal carbonized.

Yours truly,

[Signed] THEOB'D FORSTALL, V.-P.

For further information apply to

FRED. BREDEL,

332 East 17th Street, N. Y. City.

OR

G. F. KREISCHER,

132 Mangin Street, N. Y. City.

GIBBS PORTLAND CEMENT

Is guaranteed to be the finest English brand, and unsurpassed by any grade imported for making concrete and setting masonry

Extract of Paper, with tests, read before the American Society of Civil Engineers, sent on application.

HOWARD FLEMING,
Sole Agent for U. S.,
23 Liberty St., New York.

MITCHELL, VANCE & CO.,

MANUFACTURERS OF

Chandeliers

and every description of

GAS FIXTURES.

Also manufacturers of Fine Gilt Bronzes and Marble Clocks, warranted best time-keepers. Mantel Ornaments, etc.

Salesrooms, 836 Broadway, N. Y.

Special Designs furnished for Gas Fixtures for Churches, Public Halls, Lodges, etc.

HOWARD FLEMING,
23 Liberty St., New York.

IMPORTER OF

"BRIDGEND" "DINAS"

Silica FIRE Bricks

FOR COKE OVENS AND GAS WORKS.

PORTLAND AND ROMAN CEMENTS.

Correspondence Invited. Lowest Prices.



STEPHEN A. MORSE, President.
GODFREY REBMANN, Vice-Pres.

M. B. DYOTT,
Superintendent.

EDWIN F. MORSE, Secretary.
CARLTON M. WILLIAMS, Treas.

STANDARD GAS LAMP CO.,

Office, 411 Cherry St. Factory, 1101, 1103 & 1105 Frankford Av.

Philadelphia, Pa.

It is to the interest of Gas Companies and Cities to use Dyott's Patent Champion Lamps, which give double the light with the same consumption of gas, and will save 50 per cent. over others in cost of keeping in repair. Gas Companies and others intending to erect Lamps of any description will do well to communicate with us. Special Drawings furnished and Estimates given on application upon Architects', Engineers' or our Draughtsmen's Plans.

Our Patent System of Instantaneously Lighting Gas (without electricity) for R. R. Depots is unequalled. Our High Candle Power Burner is superior to the Electric Light or any other High Candle Burner. We manufacture every description of Ornamental Lamps.

Gregory's Retort Incandescent Gas Lamps.

Manufactured under Patents granted and applied for. Over 20,000 sold in New York and Brooklyn. Over 100,000 sold in the U. S. in one year. It is the only lamp that can compete with Incandescent Electric Light. Gas Companies should see that it is on sale in their city or town. They can be attached to any bracket or fixture. A Complete Revolution in Gas Lighting. The invention of GEO. H. GREGORY, Gas Expert. A pure white light obtained from Gas, which is Superior to Electric Light. All lamps are finished in nickel plate. The construction of all lamps allows the gas to be superheated before passing through the tip, rendering the illuminating properties of the gas incandescent, which causes the Brightest Light ever obtained from Gas. Lamps made in all sizes. Gas Companies should assist in introducing this new lamp, which exceeds all other devices for gas lighting. This Cut represents Office and Bracket Lamp. Price, \$18 per dozen; discount 50 per cent. in half dozen lots or more. Send for Catalogue. Address

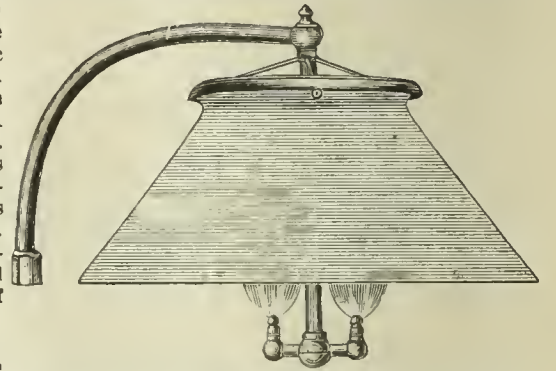

GEO. H. GREGORY, Mnfr., 337 Broadway, N. Y.

GASHOLDER TANK CONSTRUCTION, ETC.

Gas Companies and others about to erect Gasholders will find it profitable to consult W. C. WHYTE, who for over thirty years has made a specialty of

Holder Tank Excavation and Mason Work.

Fifty tanks now in operation show the sort of work done. Address

W. C. WHYTE, No. 15 Cortlandt St., N. Y. City.

DURING THE PAST YEAR, THE

NATIONAL GAS LIGHT AND FUEL CO.

218 LA SALLE ST., CHICAGO,

Have Erected Twelve Sets of Water Gas Generating Apparatus under the *Springer Cupola* System. They are as follows:

Newton Illuminating Company, Newton, Kansas.— Daily capacity, 120,000 cu. ft.

Wellington Light & Heat Co., Wellington, Kansas.— Daily capacity, 120,000 cu. ft.

Chippewa Falls, Gas Light Co., Chippewa Falls, Wis.— Daily capacity, 120,000 cu. ft.

Elkhart Gas Light & Coke Co., Elkhart, Indiana.— Daily capacity, 120,000 cu. ft.

Madison City Gas Light Company, Madison, Wis.— Daily capacity, 120,000 cu. ft.

South Bend Gas Light Co., South Bend, Indiana.— Daily capacity, 250,000 cu. ft.

Sheboygan National Gas Comp'y, Sheboygan, Wis.— Daily capacity, 120,000 cu. ft.

Salina Gas Light Company, Salina, Kansas.— Daily capacity, 120,000 cu. ft.

Rathbun Company, Deseronto, Province Ontario.— Daily capacity, 80,000 cu. ft.

Jefferson City Gas Light Co., Jefferson City, Mo.— Daily capacity, 120,000 cu. ft.

Mankato Gas Light Company, Mankato, Minnesota.— Daily capacity, 80,000 cu. ft.

Minneapolis Gas Lt. & Coke Co., Minneapolis, Minn.— Daily capacity, 1,000,000 cu. ft.

1886

1886

THE ALBO-CARBON LIGHT.

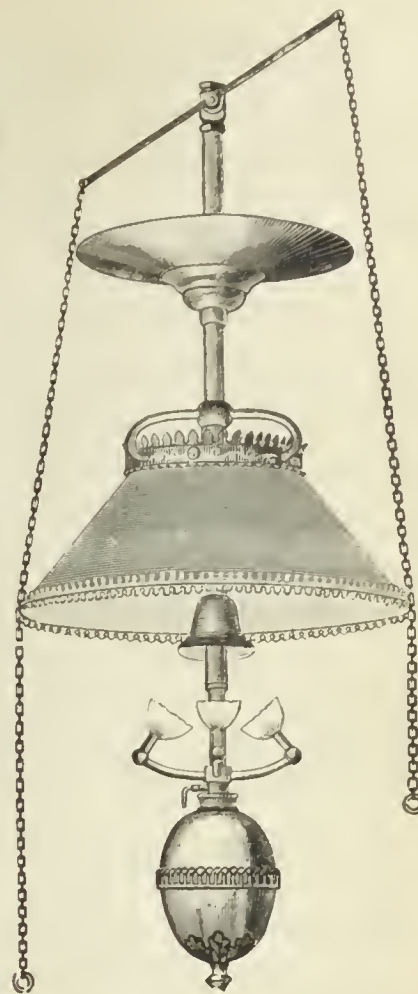
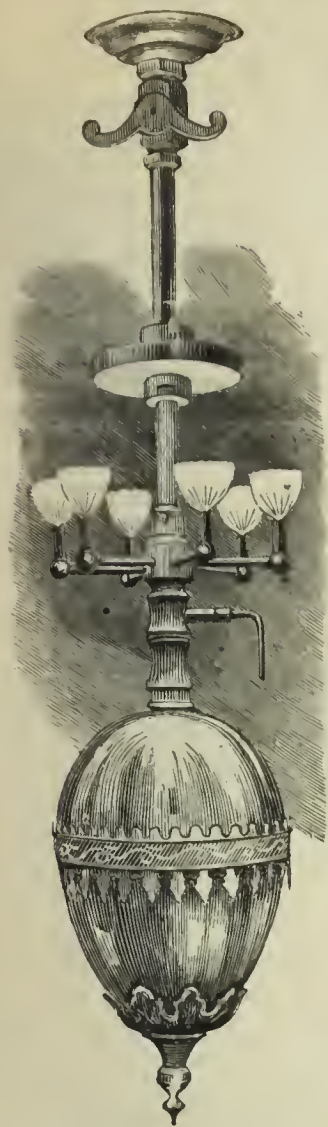

This most successful of all methods of enriching gas is based on the use of heated gas to vaporize a solid hydrocarbon, thus

COMBINING THE ADVANTAGES OF PREHEATING AND CARBURETTING.

The incoming gas passes over an extended heating surface (heated by means of the illuminating flames), and is raised to the temperature necessary to vaporize the carburetting material, which is a white, crystalline solid prepared from coal tar.

WRIT OF INJUNCTION.

In the suit between this Company, as complainant, and Newman A. Ransom *et al.*, defendants, pending in the Circuit Court of the United States for the Northern District of Illinois, on a late hearing of said cause before his Honor, Judge Gresham, Judge of said Court, an order was made and entered therein, supporting our charge of infringement of our Letters Patent No. 247,925, dated October 4, 1881, and No. 333,862, dated January 5, 1886, and sustaining our rights under said several Letters Patent, and an injunction was issued thereon, a copy of which is hereto annexed, and to which especial attention is hereby directed, viz.:

INJUNCTION WRIT.

Circuit Court of the United States of America, } ss.
Northern District of Illinois,

THE UNITED STATES OF AMERICA,

To Newman A. Ransom, and to your Counselors, Attorneys, Solicitors, Trustees, Clerks, Servants, and Agents, and to each and every of them,
Greeting:

WHEREAS, it hath been represented to the Judges of our Circuit Court of the United States for the Northern District of Illinois, in Chancery sitting, on the part of Walter J. Kidd, Complainant in his certain bill of complaint, exhibited in our said Circuit Court, on the Chancery side thereof, before the Judges of said Court, against you, the said Newman A. Ransom, to be relieved touching the matters complained of. In which said bill it is stated, among other things, that you are combining and confederating with others to injure the Complainant touching the matters set forth in the said bill, and that your actings and doings in the premises are contrary to equity and good conscience. And it being ordered that a writ of injunction issue out of said Court, upon said bill, enjoining and restraining you, and each of you, as prayed for in said bill. We, therefore, in consideration thereof, and of the particular matters in said bill set forth, do strictly command you, the said Newman A. Ransom, your Counselors, Attorneys, Solicitors, Trustees, Clerks, Servants, Agents, and each and every of you, that you DO ABSOLUTELY DESIST AND REFRAIN FROM the making, using, or sell-

ing of any Carburetting Attachments for gas fixtures substantially as described and claimed in Letters Patent numbers 247,925 and 333,862, to wit: the second claim of said Letters Patent number 247,925 and the first and second claims of said Letters Patent number 333,862, until this Honorable Court, in Chancery sitting, shall make other order to the contrary. Hereof fail not, under the penalty of what the law directs.

To the Marshal of the Northern District of Illinois, to execute and return in due form of law.

[SEAL.]

WITNESS, the HON. MORRISON R. WAITE, Chief Justice of the Supreme Court of the United States of America, at Chicago, in said District, this 19th day of January, in the year of our Lord one thousand eight hundred and eighty-seven, and of our Independence the one hundred and eleventh year.

WM. H. BRADLEY, Clerk.

Marshal's Return.

United States of America, } ss.
Northern District of Illinois,

I have served the within writ on the within defendant, Newman A. Ransom, by reading the same to and within his presence, and by delivering to him a true copy of the within, this 19th day of January, A. D., 1887.

F. H. MARSH, Marshal,
By IRA BARCHARD, Deputy.

Our suit against W. S. Horry (formerly trading as the Crystal Carbon Light Co.), Arthur Kitson (now trading as the Crystal Carbon Light Co.), and others, defendants, for infringement of our Letters Patent above mentioned and referred to, pending in the Circuit Court of the United States for the Eastern District of Pennsylvania, has not yet been reached for hearing.

THE ALBO-CARBON LIGHT COMPANY, - - - NEWARK, N. J.,
Sole Manufacturers for the United States.

GAS ENGINES.

GAS LAMPS.

BOOKS.

THE CLERK GAS ENGINE CO.,

Main Office, 1012, 1014, 1016, 1018 Filbert St., Philadelphia, Pa.

WM. W. GOODWIN, Prest.

E. STEIN, Sec.

S. LEWIS JONES, Asst. Sec.

A. J. DOTY, Supt.

The utility and convenience of the Gas Engine being no longer an open question, it only remains now for intending purchasers to select the BEST. We claim for the CLERK GAS ENGINE that it is equal to any other manufactured as regards steadiness in running, simplicity, and ease of keeping in repair, and that it gives the greatest amount of power for the least money (both in first cost and expense of running) of any engine made. In support of this claim we refer to the test of the Gas Engines made under the direction of the American Institute of New York, in December, 1885, and heretofore published in these columns. These engines are especially adapted for continuous running under heavy loads, and we can refer to Engines which have run 22 hours a day for months at a time.

Made in Sizes of 5, 10, 15, 20, and 25 Horse Power. All Engines Guaranteed for One Year.

TRADE MARK.

THE CRYSTAL CARBON LIGHT!

The Latest and Most Improved Gas Light!

ADAPTED FOR PRIVATE RESIDENCES, CHURCHES, THEATERS, STORES, ETC.

These Burners are manufactured on the principle of enriching gas by means of Naphthaline (so-called Crystal Carbon or Albo-Carbon), the invention of the Rev. W. R. Bowditch, F.R.S., of Wakefield, England, who was the original inventor and patentee of this system of gas lighting.

SPECIAL NOTICE.

Many Gas Companies find the Crystal Carbon Light a valuable competitor against the Electric Light. It is ornamental, free from the defects common to all other enriching gas burners, and is as cheap as ordinary gas chandeliers. We sell direct to gas companies, giving them the benefit of agents' discounts.

CARBONCRYSTAL.

(Trade Mark.)

A new and superior preparation for enriching gas used in conjunction with Crystal Carbon or Albo-Carbon gas lights.

The preparation is cleaner and better adapted for filling burner vessels than any hitherto produced.

Guaranteed to be chemically pure. Supplied in cans from 10 pounds up.

THIS IS THE CHEAPEST AND PUREST FORM OF ENRICHING MATERIAL.

CRYSTAL CARBON LIGHT CO.,

Main Office, No. 1018 Chestnut Street, Philadelphia, Pa.

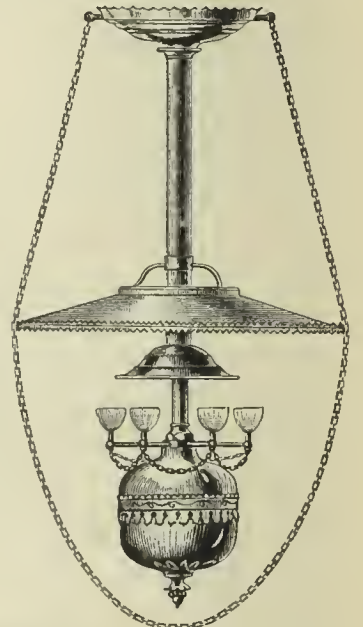

GAS

AS A SOURCE OF

LIGHT, HEAT, AND POWER.

By C. J. R. HUMPHREYS.

A Pamphlet of twenty-nine pages, treating of the use of Gas as a source of Light, Heat, and Power.

DESIGNED FOR DISTRIBUTION BY GAS COMPANIES AMONG THEIR CUSTOMERS AND OTHERS.

Price, 10 cents each, \$5 per 100, \$50 per 1,000.

Gas Companies can have their own imprint placed on cover without extra charge. All orders to be sent to

A. M. CALLENDER & CO.,

No. 42 Pine Street, N. Y. City.

GAS EXHAUSTERS

Have long been regarded as "luxuries" not to be thought of by small companies; but

CONNELLY'S JET EXHAUSTER IS WITHIN THE REACH OF ALL!

Will Pay for Itself in Six Months! Saves Labor! Lengthens the Lives of Retorts! Prevents the Formation of Carbon!
Increases the Yield from Twelve to Fifteen Per Cent.!

We find, after careful inquiry and investigation, that the majority of the Gas Works in the United States and Canada are running *without Exhausters*, which, in our opinion is due to two causes. *First.* The prices heretofore asked for Exhausters have been so high as to counteract, to a great extent, the advantages to be obtained from their use, and caused most managers to postpone their adoption indefinitely, or until their consumption had largely increased. *Second.* Many superintendents have a false impression that it will not pay to run an Exhauster in works producing less than 20,000 feet per day.

The first difficulty we overcome by selling our Exhausters at *extremely low prices*, as will readily be admitted after comparing our list with those of other manufacturers; and as to the second, we can say we have most convincing evidence from many companies operating our Exhausters that they can be used to advantage in works producing *as low as 6,000 cubic feet per day*.

In our improved Exhauster we combine the "Exhaust Tube" Gas and Steam Governors, Gas Compensator, and Bye-Pass Valves in the most compact form possible, which is a very great advantage to the machine, besides enabling us to manufacture and sell at the low prices given.

This is the only Exhauster in the market having a "compensator" in addition to the "gas governor"—a most important improvement, as it does away with all possible danger of their ever drawing air, and thus reducing the illuminating power of the gas.

FOR OIL GAS WORKS.

Our Exhausters are especially adapted for the use of Oil Gas Works; and where oil is required to dilute the gas a valve can be adjusted to *take the exact amount of air required*, thus dispensing with air pumps and their attendant labor and annoyance.

POINTS OF SUPERIORITY.

Requires *one-half the floor space* and *one-third less steam* than any other Exhauster in the market of same capacity. *More cheaply and easily connected*, as outside "Bye-Pass Valves" are dispensed with. It is the only Exhauster manufactured having "Compensator" and "Governor" *combined*, the "Compensator" with all other Exhausters being a separate and distinct machine. It is simple in construction, easily adjusted, not liable to get out of order, and *can be operated by ordinary workmen*.

NAPHTHALINE AND STEAM JET EXHAUSTERS.

As many superintendents of Gas Works believe the use of a Steam Jet Exhauster will inevitably cause trouble from *naphthaline* deposits, we recently sent out letters of inquiry to superintendents using our Steam Jet, asking for their experience, and the following replies speak for themselves. That naphthaline deposits are often unjustly attributed to Jet Exhausters is well known by many superintendents. When the cause cannot be determined it seems to be the rule to place the responsibility on the Jet Exhauster, *if they have one*; but if no Exhauster is used *the cause remains a mystery*.

OFFICE LISTOWEL GAS LT. CO., LISTOWEL, CAN., May 29, 1885.

Messrs. Connelly & Co., Ltd.: Gentlemen—The Exhauster purchased from you over three years ago, and now in use, has proven in every way all you claim for it, and has given us great satisfaction. No trouble has arisen from naphthaline.

Yours respectfully, F. W. HAY, Sec.

RICHMOND GAS CO., RICHMOND, KY, June 1, 1885.

Messrs. Connelly & Co., Ltd., 407 Broadway, N. Y.: Gentlemen—I put in your Steam Jet Exhauster last November. I think it a perfect machine, as it requires no attention whatever. Have not had any naphthaline to contend with; it would be very easy to get rid of that substance if I had it.

Yours very truly, J. B. GORDON, Supt.

HAMPTON, VA., June 3, 1885.

Messrs. Connelly & Co., Ltd.: Gents—We have been using your Steam Jet Exhauster for the past 3 years, and have never had any trouble with it whatever, either from naphthaline or any other source.

Yours truly, J. B. H. GOFF.

BRUNSWICK, ME., May 27, 1885.

Messrs. Connelly & Co., Ltd.: Dear Sirs—Your favor of 23d inst. at hand. In answer would say your Exhauster works well with us. We make an oil gas; are not troubled with naphthaline. Very truly yours, B. G. DENNISON, Prest. Brunswick Gas Lt. Co.

WILMINGTON, O., June 15, 1885.

Messrs. Connelly & Co., Ltd.: Dear Sirs—We started your make of six-inch Steam Jet Exhauster March 30, and I am pleased to state, from the time the steam was turned on, it has performed its work to our entire satisfaction. We have never had any other but a Steam Jet Exhauster, and have never been troubled with naphthaline. For many reasons I prefer it to the "rotary," and have no hesitancy in recommending it.

Yours truly, E. W. HAMLIN, Sec. Gas Co.

OFFICE LOGAN GAS LT. & COKE CO., LAGAN, HOCKING CO., O., May 29, 1885.

Connelly & Co., Ltd.: Gentlemen—In answer to yours of 27th we have to say that the Steam Jet Exhauster put in for us by you last fall has been used constantly since, and, up to this time, we have had no trouble with naphthaline. We have heard many gas men say that a Steam Set Exhauster is liable to bring on trouble with naphthaline, and we have had that fear before us; but so far we have escaped, and we trust we may not have any experience with that gas manager's bugbear.

Yours truly, LOGAN GAS LT. & COKE CO.

OFFICE ATHENS GAS LT. CO., ATHENS, O., May 30, 1885.

Messrs. Connelly & Co., Ltd.: Dear Sirs—We take pleasure in giving you an unqualified endorsement of your Steam Jet Exhauster. It has been in place almost a year; been tested in all seasons and under all conditions; it has always proved true to the work assigned it. We have had no naphthaline deposit, nor any trouble chargeable to the Exhauster. Nothing but good has come from it, and great good at that. We can't do without it.

Very truly yours, C. H. WELCH, Supt.

OFFICE MEADVILLE GAS WORKS, MEADVILLE, PA., May 29, 1885.

Connelly & Co., Ltd.: Gents—Yours of the 27th received and contents noted. Would say that after using your Steam Jet Exhauster for the past 18 months, find it perfectly satisfactory in every way. So far as naphthaline is concerned, we have had no trouble whatever as yet.

Yours, GEO. S. CULLUM, Supt.

NYACK AND WARREN GAS LT. CO., NYACK, N. Y., May 25, 1885.

Connelly & Co., Ltd.: Gentlemen—Since your Jet Exhauster has been here there has been no trouble, and certainly *no naphthaline*. The only trouble I have experienced was the Jet becoming clogged with tar last week, and I cleaned it in a few minutes. It has run over three years without any trouble or cost for repairs.

Yours truly, A. MURRAY, Lessee and Manager.

OFFICE CADIZ GAS LT. CO., CADIZ, O., May 29, 1885.

Messrs. Connelly & Co., Ltd.: Gentlemen—Yours of 22d, inquiring how our Steam Jet Exhauster is doing, has been received. We have been using one of your Exhausters about four years, and with the best of satisfaction. We have less trouble with carbon in retorts, make more gas from same amount of coal than before, and have no trouble with stoppage in pipes or trouble from tar; and as regards naphthaline, we are not troubled with it, and do not know what it is to have any stoppage in pipes from naphthaline.

Very truly yours, A. N. HAMMOND, Sec.

SIDNEY (OHIO) GAS WORKS, June 1, 1885.

Connelly & Co., Ltd.: Gentlemen—We have now been using one of your Steam Jet Exhausters about five months, and thus far it has given us perfect satisfaction. We get a better yield and a more brilliant quality of gas from the coal. We have seen in papers and heard from different individuals that Steam Jet Exhausters were productive of naphthaline. "We can't see it," as we have found no trace of it in the works, mains, services, or meters.

Respectfully yours, W. W. GRAHAM, Supt.

CONNELLY & CO., LTD., No. 17 Broadway, New York City.

**T. C. HOPPER'S
AUTOMATIC DIFFERENTIAL GAS GOVERNOR**

Is now in Practical Operation, doing Perfect Automatic Service with Great Precision.

This Governor will do all and more than any other Governor on the Market.

BE SURE TO THOROUGHLY INVESTIGATE THE SUPERIOR MERITS OF THIS GOVERNOR BEFORE PURCHASING.

For Simplicity and Reliable Work it has no Equal. Correspondence Solicited.

T. C. HOPPER & CO., - - Manufactory, 2227 Wood Street, Phila, Pa.

CONNELLY & CO., LTD.

MANUFACTURERS OF

Steam-Jet Exhausters

Requires one-half the floor space and one-third less steam than any other Exhauster in the market. More cheaply and easily connected, as outside by-pass valves are dispensed with. It is the only Exhauster manufactured having Compensator and Governor combined; the Compensator with all other Exhausters being a separate and distinct machine. It is simple in construction, easily adjusted, not liable to get out of order, and can be operated by ordinary workmen. Over 1,000 now in use.

No. 177 Broadway, New York.

LUDLOW VALVE MFG. CO.

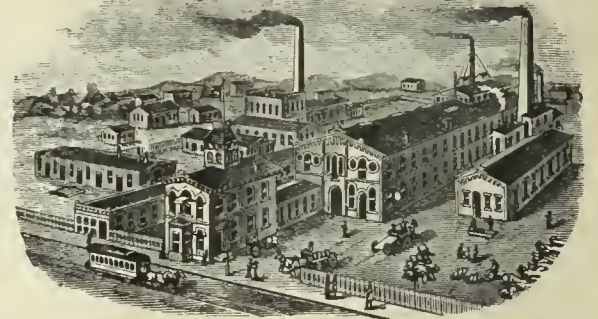

OFFICE AND WORKS,

938 to 954 River Street and 67 to 83 Vail Av. TROY, N. Y.

Hydraulic Main Dip Regulators, also Check Valves, Foot Valves, Yard wash and Fire Hydrants. Send for Circulars.

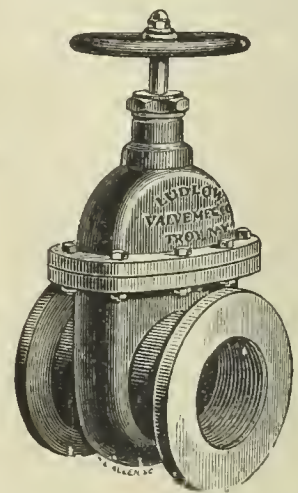

Valves.—Double and Single Gate, 1/2 in. to 48 in., outside and inside Screws. Indicator, etc., for Gas, Water, Steam, and Oil. Send for Circulars.

G. S. COOK, Pres. THOS. DAVENPORT (late Davenport Bros.), Sec. & Treas

**BARTLETT
Street Lamp Mfg. Co.**

MANUFACTURERS OF

Bartlett's Patent

GLOBE LAMPS.

FOR

Streets, Parks, Railroad Stations, Public Buildings, Etc.

LAMP POSTS A SPECIALTY.

Office and Salesroom

No. 35 Howard Street, N. Y. City.

Gas Companies and others intending to erect lamps and posts will do well to communicate with us.

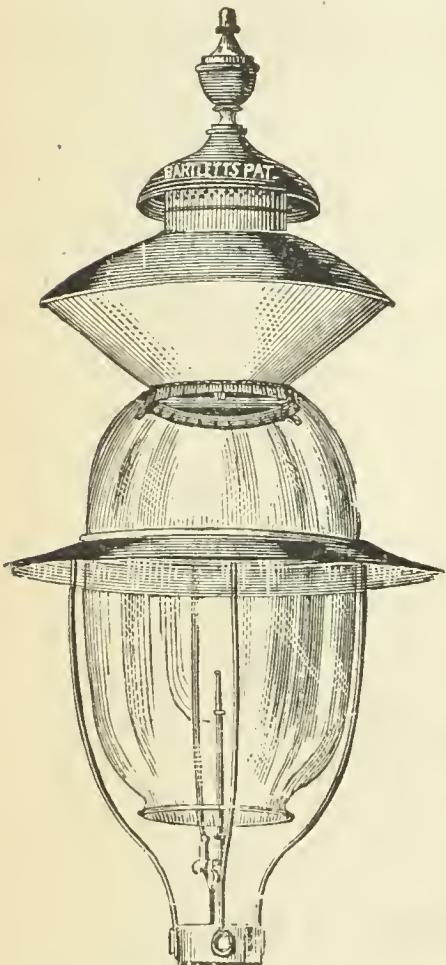

F. M. ROOTS.

S. C. ROOTS

D. T. ROOTS.

P. H. & F. M. ROOTS, PATENTEES AND MANUFACTURERS OF

IMPROVED GAS EXHAUSTER

WITH ENGINE ON SAME BED PLATE, OR WITHOUT.

BYE-PASSES, GAS VALVES, GOVERNORS, ELBOWS, PIPE-FITTINGS, Etc., FURNISHED TO ORDER.

P. H. & F. M. ROOTS, Patentees & Manufacturers, CONNERSVILLE, IND.

S. S. TOWNSEND, General Agent, 22 Cortland St.

COOKE & CO., Selling Agents, 22 Cortland St., N. Y.

✻ SEND FOR ILLUSTRATED CATALOGUE AND PRICE LIST. ✻

John McLean

Manufacturer of

GAS VALVES.

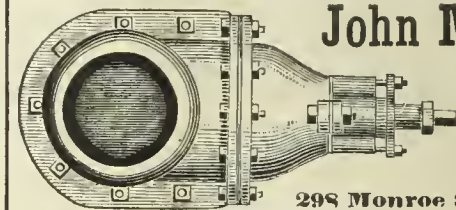

298 Monroe Street, N. Y.

GAS vs. ELECTRIC LIGHT.

We would invite attention to the able and exhaustive argument of General A. Hickenlooper, President of the Cincinnati Gas Light and Coke Company, contained in a handsome pamphlet of 96 pages, entitled

"EDISON'S INCANDESCENT ELECTRIC LIGHTS FOR STREET ILLUMINATION. REPORT OF AN ARGUMENT DELIVERED BY A. HICKENLOOPER BEFORE THE COMMITTEE ON LIGHT, MUNICIPAL COUNCIL, CITY OF CINCINNATI, JULY 22, 1886."

This is a subject of special interest to all Gas Light Companies.

Prices.

25 copies.....	\$7.50	100 copies.....	\$22.50
50 copies.....	12.50	250 copies.....	50.00

A sample copy will be sent by mail on receipt of 50 cts.

A. M. CALLENDER, & CO., 42 PINE ST., N. Y. CITY.

C. W. HUNT CO.,

No. 111 Broadway, N. Y. City.

MANUFACTURERS OF

Coal Handling Machinery,

AUTOMATIC RAILWAY, HOISTING ELEVATOR, CABLE RAILWAY, STEAM SHOVEL, HOISTING ENGINES, COAL TUBS, COAL & COKE CARS.

Plans and Specifications made for the

Erection of Coal Storage Buildings

Send for a Descriptive Pamphlet.

GAS STOVES.

GAS STOVES.

GAS STOVES.

THE AMERICAN METER CO.,

MANUFACTORIES,

508 to 514 West Twenty-second St., N. Y. Arch and Twenty-second St., Phila.

Nos. 244 & 246 North Wells Street, Chicago, Ill.

AGENCIES,

No. 177 Elm Street, Cincinnati, Ohio. Nos. 122 & 124 Sutter Street, San Francisco Cal.

No. 810 North Second Street, St. Louis, Mo.

NEW

INCANDESCENT

Gas Fires

AND

OPEN

Fire Place

Heaters.

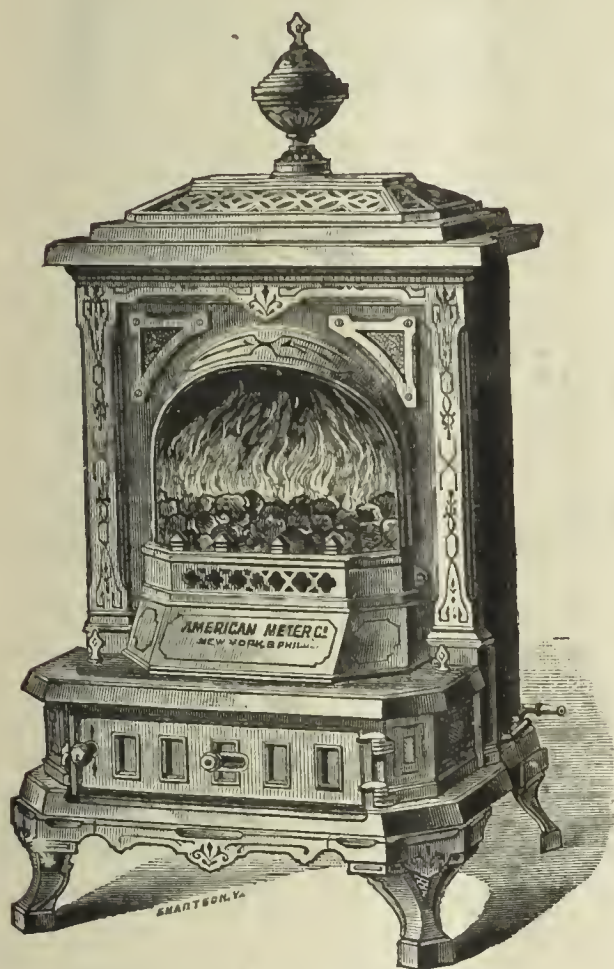

Open Fire Place Heater No. 19.
Fitted with the new Incandescent Gas Fire.

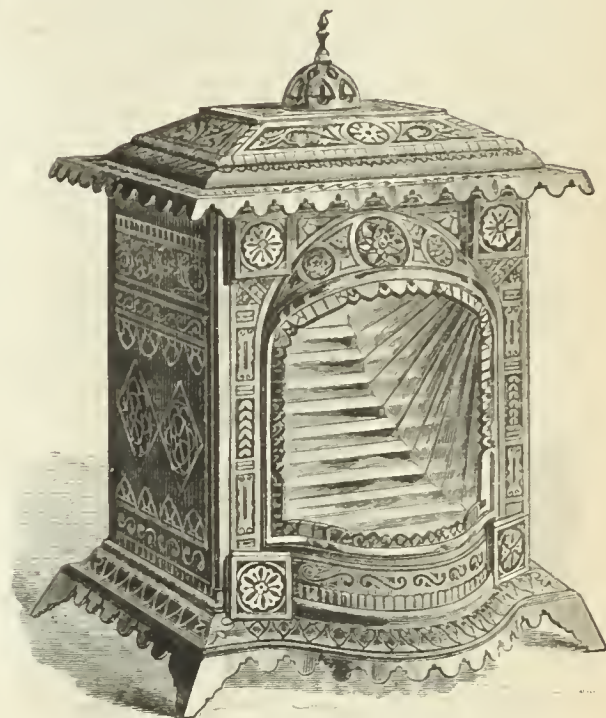

Open Fire Place Heater No. 17C.
Fitted with Illuminating Burners and Copper Reflectors.

We call attention to Special Apparatus Heated by Gas for Manufacturing Purposes.

GAS FURNACES FOR TINMEN'S USE; FURNACES FOR MELTING SOLDER AND TYPE METAL; APPARATUS FOR BENDING CARRIAGE PANELS, NOW IN SUCCESSFUL OPERATION IN CARRIAGE MANUFACTORIES; WATER HEATERS FOR KITCHEN BOILERS, BATHS, ETC., AND FOR ATTACHING TO HEATING COILS AND PIPES FOR CONSERVATORIES.

THE COMPANY MANUFACTURE

GAS STOVES FOR COOKING AND HEATING PURPOSES

In all Sizes, for Domestic, Restaurant, and Hotel Use.

These Stoves may be seen in operation at our Retail Store, No. 223 Sixth Avenue, N. Y. Call and examine.

SEND FOR CATALOGUE OF TWENTY DIFFERENT STYLES OF HEATING STOVES.

RETORTS AND FIRE BRICK.

J. H. CAUTIER & CO.,

CORNER OF

GREENE AND ESSEX STREETS,
JERSEY CITY, N. J.

MANUFACTURERS OF

**Clay Gas Retorts,
Gas House Tiles,
Fire Bricks, Etc. Etc.****Ground Clay, Fire Brick and
Fire Sand in Barrels,**J. H. GAUTIER.
C. E. GREGORY.T. B. GAUTIER.
C. E. GAUTIER.**BROOKLYN****Clay Retort & Fire Brick Works,**
(EDWARD D. WHITE & CO.)Manufacturers of Clay Retorts, Fire Brick,
Gas House and other Tile.VAN DYKE, ELIZABETH, RICHARDS & PARTITION STS.
Office, 88 Van Dyke St., Brooklyn, N. Y.

RETORTS AND FIRE BRICK.

LACLEDE FIRE BRICK MFG. CO.,

MANUFACTURERS OF

Fire Brick, Gas Retorts,

AND

ST. LOUIS STANDARD SEWER PIPE.Blast Furnace and Cupola Linings, every description of Fire
Clay Material, Fire Clay Flue Linings, Chimney Tops
Dry Milled and Crude Fire Clays, etc.

OFFICE AND DEPOT

901, 903, and 905 Pine Street,
ST. LOUIS, MO.

ESTABLISHED IN 1845.

B. KREISCHER & SONS,

OFFICE FOOT OF HOUSTON ST., E.R., N.Y.

Gas Retorts,**TILES, FIRE BRICK.**

AND EVERYTHING IN THE FIRE CLAY LINE.

RETORTS AND FIRE BRICK.

MANHATTAN

FIRE BRICK & ENAMELLED CLAY

RETORT WORKS.**ADAM WEBER.****CLAY GAS RETORTS**

AND RETORT SETTINGS

FIRE BRICKS, TILES, ETC.,

Office and Works, 15th Street and Avenue C., N. Y.

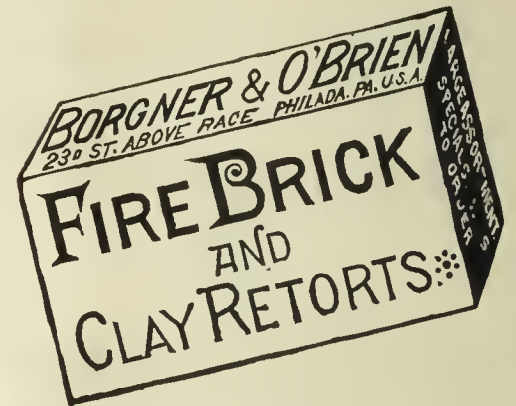

Works,

LOCKPORT STATION, PA.

—ESTABLISHED 1864.—

JAMES GARDNER, JR.,

Successor to WILLIAM GARDNER & SON.

Office, Rooms 19 & 20, Lewis Block,
PITTSBURGH, PA. P. O. Box 373.**Fire Clay Goods for Gas Works.**

CHAS. H. SPRAGUE & SON, No. 70 KILBY STREET, BOSTON, MASS., Agents for the New England States.

OFFICE, 418 to 422 East 23d St., New York.

ESTABLISHED 1856.

WORKS, PERTH AMBOY, NEW JERSEY.

HENRY MAURER & SON,**Excelsior Fire Brick & Clay Retort Works****CLAY GAS RETORTS, BENCH SETTINGS, FIRE BRICK, TILES, ETC.****CHICAGO****Retort & Fire Brick Works,**

OFFICE AND FACTORY,

Clark, Forty-Fifth, and La Salle Streets,
CHICAGO, ILL.

GEORGE C. HICKS, PRES. PAUL P. USTIN, SEC. & TREAS.

STANDARD

Clay Retorts and Settings.**BLOCKS & TILES**

Of every Shape and Size to Order.

Standard Fire Bricks.**GEROULD'S IMPROVED RETORT CEMENT.**A Cement for patching retorts, putting on mouthpieces, and
making up all bench-work joints. This Cement is mixed ready
for use. Economic and thorough in its work. Fully warranted
to stick. For recommendations and price list address**C. L. GEROULD,**
Manchester, N. H.

Western Agent, H. T. GEROULD, Mendota, Ill.

OAKHILL**GAS RETORT & FIRE BRICK**

Works.

Proprietors,

PARKER-RUSSELL MINING & MFG. CO.

City Office, 711 Pine Street,

ST. LOUIS, MO.Our immense establishment is now employed almost entirely in
the manufacture of**MATERIALS FOR GAS COMPANIES.**We have studied and perfected three important points. Our re-
torts are made to stand changes of temperature, the strongest
heats of the furnace, and the abrasion of feeding and emptying.
Our customers are in almost every State of the Union, to all of
whom we refer.

THOS. SMITH, Prest.

AUGUST LAMBLA, Vice-Prest. & Sup

BALTIMORE**RETORT & FIRE BRICK CO.**

MANUFACTORY AT

LOCUST POINT, BALTIMORE, MD.

Connection with the City by Telephone.

Clay Retorts, Blocks & Tiles,**FIRE BRICK, FIRE CLAY,****AND FIRE CEMENT.**Red and Buff Ornamental Tiles and Chim-
ney Tops. Drain and Sewer Pipe (from
2 to 30 inches). Baker Oven Tiles
12x12x2 and 10x10x2.**WALDO BROS., 88 WATER ST., BOSTON, MASS**

Sole Agents the New England States

RETORTS AND FIRE BRICK.

REGENERATIVE FURNACES.

STEAM PUMPS.

EVENS & HOWARD,

916 Market St., St. Louis. Mo.
Works, Howard Station, Mo. Pacific R.R.

Fire Brick, Gas Retorts

AND

RETORT SETTINGS.

Sewer Pipe, 3 to 24 in. diameter.

Glass Pot Clay, Ground Fire Clay, in barrels and in bulk. All kinds of Fire Clay Goods.

Cincinnati Gas Retort & Fire Brick Works.

—ESTABLISHED 1872.—

CHAS. TAYLOR,

MANUFACTURER OF

Gas Retorts, Fire Brick, and Tile.

Blast Furnace Linings, Cupola Blocks, Boiler Tiles, Grate Settings, and Stove Linings. Fire Cement, Fire Clay, Fire Sand, and all other Fire Clay Goods.

Branch Works, New Cumberland, W. Va.

GENERAL OFFICE AND WORKS,

Burns St., Cincinnati, Ohio.

Stettiner

**Chamotte Fabrik Actien
Gesellschaft,**

Formerly DIDIER,

(Patentees of the Dr. Schilling & Dr. Bunte
Regenerative Furnace)

STETTIN, GERMANY.

The attention of all Gas Engineers is called to our Fire-Proof
Material, viz.:

CLAY GAS RETORTS

(ENAMELED AND UNENAMELED),

Blocks, Tiles

AND

EXTRA FIRE BRICK,

Pronounced by the highest authorities as superior to and exceeding any other similar manufacture. The component of aluminum contained in our material (up to 45 per cent.) is larger than in any other material heretofore sold in the United States; whilst the uniformity of the goods is assured by the most scrupulous analysis of the clay used.

For any further information and prices please apply to

EMIL LENZ,

2 & 4 Stone St., Room 19, N. Y. City.

JARVIS ENGINEERING CO.,

61 Oliver St., Boston, Mass.

CONTRACTORS FOR ERECTING

**COMPLETE STEAM OUTFITS FOR ELECTRIC
LIGHTING STATIONS.**

Steel Boilers set with Jarvis Pat. Boiler Setting,

To burn **COKE SCREENINGS** for Fuel.

ARMINGTON & SIMS CO. ENGINES,

Belting direct to Dynamos, without using Shafting.

SEND FOR CIRCULARS.

ADAM WEBER'S
New and Improved Regenerative Furnace.

ESPECIALLY ADAPTED FOR USE IN SMALL GAS WORKS.

**A Saving of at Least Forty per Cent. over
Old Methods.**

Cheapness of construction and absence of elaboration are the chief characteristics of this Furnace. It is also applicable in cases where it is not convenient to excavate deeply below the line of the retort house.

Correspondence respectfully solicited. Descriptive Circulars on application.

Manhattan Fire Brick & Enameled Clay Retort Works.

OFFICE, 633 EAST FIFTEENTH STREET, N. Y. CITY.

MUNICH REGENERATIVE FURNACE

System Drs. Schilling and Bunte.

Greatest Durability! Minimum of Attention!

COMPLETE DISTILLATION IN 3½ HOURS.

Ten to Thirteen Pounds of Coke to Hundredweight of Coal.

NO CLINKER. NO CARBONIC OXIDE IN THE REGENERATIVE FLUES.

Almost Automatic in Action.

The Most Successful Regenerative Furnace in Use.

BARTLETT, HAYWARD & CO.

Agents for the United States.

THE A. S. Cameron Steam Pump,

THE STANDARD OF EXCELLENCE.

Upward of 30,000 in Use.

BEST GAS WORKS PUMP
Ever Introduced.

Adapted to Every Possible Duty.

A. S. Cameron Steam Pump Works.
Foot East 23d St., N. Y.



GEO. SHEPARD PAGE,

No. 69 Wall Street, N. Y. City.

REPRESENTING

THE BOWER GAS LAMP.

C. & W. Walker's Carbonic Acid & Tar Extracting Washer

B. DONKIN & CO.'S PAT. IMP. GAS VALVE.

Young & Beilby's Patents. Henry Aitkin's Patents.

R. P. SPICE, London, Eng. HENRY SIMON, Manchester, Eng.

GAS AND WATER PIPES.

GAS AND WATER PIPES.

ENGINEERS.

SAM'L R. SHIPLEY, Pres.
HENRY B. CHEW, Treas.

JAS. P. MICHELLON, Sec.
WM. SEXTON, Supt.

GLOUCESTER IRON WORKS,
GLOUCESTER CITY, N. J.



Cast Iron Gas & Water Pipes, Stop Valves, Fire Hydrants, Gasholders. &c.
Office No. 6 North Seventh Street, Philadelphia.

ESTABLISHED 1856.

WARREN FOUNDRY AND MACHINE CO.,

WORKS AT PHILLIPSBURGH, N. J.
NEW YORK OFFICE, 162 BROADWAY.

Cast Iron Water and Gas Pipe

FROM TWO TO FORTY-EIGHT INCHES DIAMETER.
ALSO ALL SIZES OF

FLANGE PIPE for Sugar House and Mine Work.
Branches, Bends, Retorts, Etc., Etc.

436-1

MATTHEW ADDY, President.

W. L. DAVIS, Selling Agent.

GEO. P. WILSHIRE, Sec. & Treas.

Cincinnati and Newport Iron and Pipe Company,
NEWPORT, KY.

Lamp Posts
AND
BENCH CASTINGS



Branch
AND
SPECIAL CASTINGS

A Specialty.

Large & Heavy Castings for General Work.

FOR GAS & WATER CO'S.

Manufacture Pipe from 2 to 48 inches. All work guaranteed first quality.

Pancoast & Rogers.

WROUGHT IRON PIPE,

VALVES AND GATES,

Cast Iron Gas & Water Pipe.

28 Platt and 15 Gold St., New York.

The Management of Small Gas Works.

By C. J. R. HUMPHREYS. Price, \$1.

A. M. CALLENDER & CO., 42 Pine St., N. Y.

P. D. WANNER, Chairman. A. H. MELLERT, Sec. & Treas.

MELLERT FOUNDRY & MACHINE CO., Ltd.
Reading, Pa.



Specials—Flange Pipe, Valves and Hydrants,
Lamp Posts, Retorts, etc.

General Foundry and Machine Work.

JOHN FOX, Selling Agent. 160 Broadway, N.Y.

THE OHIO PIPE COMPANY,

MANUFACTURERS OF

Cast Iron Gas & Water Pipe,

BRANCH AND SPECIAL CASTINGS.

Gas-House Bench Castings, Hydraulics, Lamp Posts, Flange Pipe
and Specials, Architectural Castings, Building Columns,
Joists, Cellar Grates, Sash Weights, etc.

GENERAL FOUNDERS AND MACHINISTS.

Columbus, Ohio.

M. J. DRUMMOND,



SPECIAL CASTINGS AND LAMP POSTS.

95 Liberty St., - New York.

JOS. R. THOMAS, C.E.,

May be Consulted on all Mat-
ters Relating to Gas Works
and Gas Manufacture.

ADDRESS THIS OFFICE.

WM. FARMER, ENGINEER,

32 Park Place, Room 36, New York.

THE CHEMIST'S ASSISTANT; OR, KINDERGARTEN SYSTEM OF CHEMISTRY.

A system by which the elements and their valences are repre-
sented by illustrations and solid bodies.

BOX AND PAMPHLET COMPLETE, \$2.50.

WM. HENRY WHITE,

CONSULTING AND CONSTRUCTING

Gas Engineer & Contractor

Estimates, Plans, and Specifications furnished for new wo
extensions of existing works.

No. 32 Pine Street, New York City.

Correspondence solicited.

WM. GARDNER,

Gas Engineer,

Lewis Block, Room 20, Pittsburgh, Pa.

Those who intend to make alterations in existing gas plants, or
who contemplate the erection of new works, will find it to their
interest to open correspondence with the above. Plans made
and estimates furnished.

GAS LAMPS.

SCRUBBERS AND CONDENSERS.

The Siemens and Lungren REGENERATIVE GAS LAMPS.

A System of Burning Gas whereby its Illuminating Power is Increased from 300 to 400 per ct. without the Expense, Trouble and Annoyance resulting from the use of Hydrocarbon Enriching Material.

The Siemens-Lungren Company received the only Silver Medal or Highest Award for Gas Burners at the "Novelties" Exhibition of the Franklin Institute, held at Phila., Oct., '85.

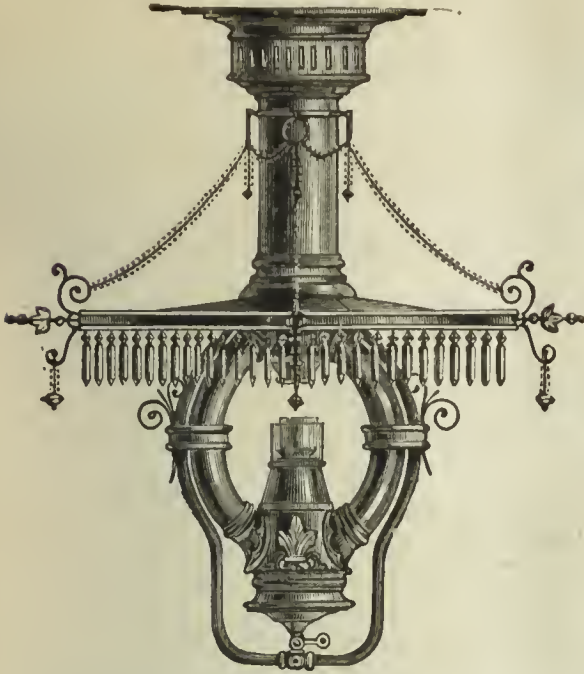

SIEMENS LAMP.



LUNGREN LAMP

THIRTEEN CANDLE POWER PER CUBIC FOOT OF GAS!

This result is obtained

SIMPLY BY THE SCIENTIFIC APPLICATION OF THE REGENERATIVE PRINCIPLE.

Consequently this largely increased illumination is always maintained without further cost and frequent attention.

THE SIEMENS-LUNCREN COMPANY,

N. E. Cor. 21st. St. and Washington Av., Phila., Pa.

THE PATENT "STANDARD" WASHER-SCRUBBER

Has been adopted by gas companies in all parts of the world. Between 300 and 400 companies, with the enormous daily output of over 300,000,000 cubic feet, are now using it. "Standard" Washer-Scrubbers have been erected for the following gas light companies since Jan. 1, 1886:

WALLASEY, ENGLAND.....	750,000 cubic feet.	RICHMOND, SURREY, ENGLAND	1,500,000 cubic feet.
NEWARK, ENGLAND.....	350,000 "	BRIDGEPORT, U. S.....	500,000 "
BUFFALO, U. S. (MUTUAL).....	500,000 "	TORONTO, CANADA.....	1,000,000 "
BERLIN, GERMANY.....	1,250,000 "	HARTFORD, U. S.....	1,000,000 "
SO. BRISBANE, AUSTRALIA.....	300,000 "	DETROIT, U. S.....	750,000 "
LEEDS, ENGLAND.....	2,000,000 "	SINGAPORE, CEYLON.....	300,000 "
FURTH, GERMANY.....	400,000 "	BRUNSWICK, GERMANY.....	300,000 "
FREIBURG, GERMANY.....	200,000 "	LILLE, FRANCE.....	750,000 "
NINE ELMS, LONDON.....	3,000,000 "	CADIZ, SPAIN.....	300,000 "
MELBOURNE, AUSTRALIA (2).....	3,000,000 "	READING, ENGLAND.....	2,000,000 "
GLUCKAUF COKE WORKS, GERMANY.	200,000 "	LINCOLN, U. S.....	250,000 "
BOURNEMOUTH, ENGLAND.....	1,000,000 "	ST. LOUIS, U. S. (LACLEDE).....	1,000,000 "
		BROOKLYN, U. S.....	2,000,000 "

That this apparatus is really the *standard* is indicated by the following names of important houses who represent this invention in the different countries of the world:

FRANCE & BELGIUM, Mons. J. A. Berly, 31 Rue Boinod, Paris. HOLLAND & DUTCH COLONIES, Mess. W. Hoven & Zoon, Rotterdam.

GERMANY and AUSTRO-HUNGARY, Berlin-Anhaltische-Actiengesellschaft, Berlin, Moabit, and Dessau.

RUSSIA, Mr. F. Bley, Galernaya, 44, St. Petersburg. SPAIN, Mess. Nicolas, Chamon, Foiret & Cie., 29 Rue Claude-Vellefaux, Paris.

ITALY & MALTA, Sig. E. Canziani, 26 & 28 Portici, Vittorio Emmanuele, Genoa. Sig. Fratelli Scheuer, Via Chiaja, 124, Naples.

NEW SOUTH WALES, Messrs. W. Coward & Sons, 143 Queen Victoria St., London.

NEW ZEALAND and VICTORIA, Messrs. G. D. Jennings & Co., 28 Gracechurch St., London.

Companies in the U. S. adopting this apparatus can now be assured of a market for the Ammoniacal Liquor at a remunerative price. Correspondence for purchase of "Standards" and Ammoniacal Liquor is solicited by the

SOLE AGENT AND MANUFACTURER FOR THE WESTERN HEMISPHERE,

GEO. SHEPARD PAGE, 69 WALL STREET, NEW YORK

GAS WORKS APPARATUS AND CONSTRUCTION.

GAS WORKS APPARATUS AND CONSTRUCTION.

WORKS: { MILLVILLE, N. J.
FLORENCE, "
CAMDEN, "

R. D. WOOD & CO.,

OFFICES: { 400 CHESTNUT ST.,
PHILADELPHIA.

CAST-IRON PIPE 1½ to 72 Inches in Diameter.

Water Machinery and Gas Apparatus.

HEAVY CASTINGS.

HOLDERS,

LAMP POSTS,

VALVES,

PURIFIERS,

CONDENSERS,

BENCH WORK,

METER CASES.

FLOORS AND ROOFS,

FLANGED PIPE,

FIRE HYDRANTS,

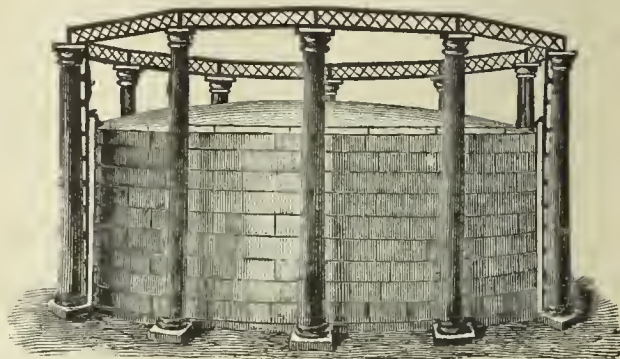
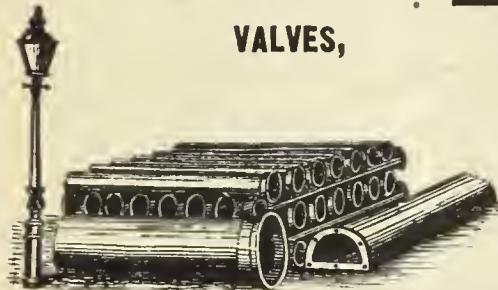

Estimates and Specifications for
NEW WORKS or **EXTENSIONS**
or **ALTERATIONS** of **OLD ONES.**

SMITH & SAYRE MFG. COMPANY,

G. G. PORTER, Prest.

245 Broadway, N. Y.

CHAS. W. ISBELL, Sec'y.

Machinery & Apparatus for Gas Works

Drawings, Plans, and Estimates Furnished for the Improvement, Extension, or Alteration of Gas Works, or for the Construction of New Works.

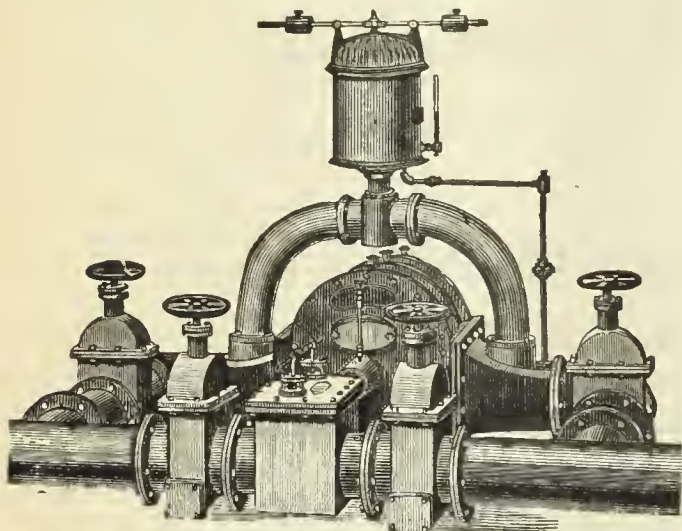

Mackenzie's Patent Rotary and Steam Jet Gas Exhausters, Governors, Compensators, Condensers, Washers, Scrubbers. Isbell's Patent Automatic Street Pressure Governor, Gas and Water Valves, Hydraulic Main Dip Regulator, Bench Castings, etc. Purifying Boxes and "Standard" Scrubbers. Isbell's Patent Self-Sealing Retort Doors.

SOUTHWARK FOUNDRY AND MACHINE COMPANY,

Successors to MERRICK & SONS,

GAS APPARATUS,

Holder, Purifiers, Washers, Etc., Etc. Boiler and Tank Work. Steam Engines. Hydraulic Machinery. Bessemer Plants, Etc.

Washington Ave. and Fifth Street, Philadelphia, Pa.

MORRIS, TASKER & CO.,

Limited,

Builders of Gas Works,

PHILADELPHIA PA.

GOODWIN'S DIRECTORY

OF THE

GAS LIGHT COMPANIES OF THE UNITED STATES & CANADA

Price, \$10.00.

Orders may be sent to

A. M. CALLENDER & CO., No. 42 Pine Street, N. Y. City.

GAS WORKS APPARATUS AND CONSTRUCTION.

GAS WORKS APPARATUS AND CONSTRUCTION.

JAMES R. FLOYD,

(SUCCESSOR TO HERRING & FLOYD)

Oregon Iron Works,

531 to 543 West 20th St., N. Y.

Practical Builders of Gas Works,

MANUFACTURERS OF

**ALL KINDS OF CASTINGS
AND
APPARATUS FOR GAS-WORKS.**

BENCH CASTINGS

from benches of one to six Retorts each.

**WASHERS: MULTITUBULAR AND
AIR CONDENSERS; CONDENSERS;
SCRUBBERS**

wet and dry), and

EXHAUSTERS

for relieving Retorts from pressure.

BENDS and BRANCHES

all sizes and description.

FLOYD'S PATENT

MALLEABLE RETORT LID.

PATENT

SELF-SEALING RETORT LIDS.

FARMER'S

PATENT BYE-PASS DIP-PIPE.

SABBATON'S PATENT

FURNACE DOOR AND FRAME.

BUTLER'S

COKE SCREENING SHOVELS.

GAS GOVERNORS,

and everything connected with well regulated Gas Works at low price, and in complete order.

SELLER'S CEMENT

for stopping leaks in Retorts.

N. B.—STOP VALVES from three to thirty inches—at very low prices.

Plans, Specifications, and Estimates furnished.

KERR MURRAY MFG. CO.,

MANUFACTURERS OF

Single Lift and Telescopic

GASHOLDERS.

Built, 1884:

Altoona, Pa.	Capacity, 160,000 cubic feet.
Pittsburgh, Pa.	" 250,000 "
" "	" 220,000 "
Bellaire, Ohio.....	" 50,000 "
Youngstown, Ohio.....	" 60,000 "
Canton, "	" 60,000 "
Akron, "	" 80,000 "
Xenia, "	" 10,000 "
Adrian, Mich.....	" 65,000 "
Ypsilanti, Mich.....	" 25,000 "
Muskegon, "	" 70,000 "
South Bend, Ind.....	" 70,000 "
Anderson, "	" 20,000 "
Plainfield, "	" 10,000 "
Springfield, Illinois.....	" 100,000 "
Evanston, "	" 50,000 "
Freeport, "	" 35,000 "
Elgin, "	" 60,000 "
Sheboygan Wis.....	" 20,000 "
Key West Fla.....	" 10,000 "

Plans and estimates furnished for the erection of new and the rebuilding of old works. Address

Kerr Murray Mfg. Co.,

FORT WAYNE, IND.

CONTINENTAL WORKS.



GASHOLDERS OF ANY MAGNITUDE.

T. F. ROWLAND, Proprietor,

GREENPOINT, BROOKLYN, N. Y.

ENGINEER AND MANUFACTURER OF

GAS-HOLDERS.

CONDENSERS, SCRUBBERS, VALVES,

PURIFIERS, RETORTS, and HY-

DR АуLIC MAINS,

and all other articles connected with the Manufacture and Distribution of Gas. Plans and Specifications prepared and Proposals given for the necessary Plant for Lighting Cities, Towns, Mansions, and Manufactories.

H. RANSHAW, Prest. & Mangt. WM. STACEY, Vice-Prest. T. H. BIRCH, Asst. Mangr. R. J. TARVIN, Sec. & Treas.

STACEY MFG. CO.,

MANUFACTURERS OF

Single and Telescopic Gasholders,

IRON ROOFS, BRIDGES, LAMP POSTS,

Water and Oil Tanks, Coal Elevator Cars,

COKE CRUSHERS, BENCH CASTINGS,

And all kinds of Wrought and Cast Iron Work used in the erection of Coal and Oil Gas Works. Rolling Mill Machinery and Heavy Castings a Specialty.

Foundry:

33, 35, 37 & 39 Mill Street.

Wrought Iron Works:

16, 18, 20, 22, 24 & 26 Ramsey Street.

Cincinnati, Ohio.

BARTLETT, HAYWARD & CO.,

Office, German & Calvert.

BALTIMORE, MD.

Works, Pratt & Scott.

PURIFIERS.

Roofs.

Bench Castings.



SCRUBBERS.

BOILERS.

CONDENSERS

GASHOLDERS.

CONSTRUCTING ENGINEERS AND BUILDERS OF GAS WORKS.

1842. DEILY & FOWLER, 1886.

Laurel Iron Works.

Address, No. 39 Laurel Street, Philadelphia, Pa.

MANUFACTURERS OF

GASHOLDERS,

Single or Telescopic, with Cast or Wrought Iron Guide Frames.

HOLDERS BUILT SINCE 1881:

Scranton, Pa. (2d)	Holidaysburg, Pa.	Jackson, Mich.	Montgomery, Ala.	New Castle, Pa.
West Point, N. Y.	Galveston, Texas (2d.)	Kalamazoo, Mich. (3d.)	Newport, R. I.	Long Island City, N. Y.
Fitchburgh, Mass.	Marlboro, Mass.	Glen Island, N. Y.	Portland, Oregon.	Macon, Ga.
New London, Conn.	Denver, Col.	Warren, Ohio.	Allegheny, Pa. (2d.)	York, Pa.
Derby, Conn.	Chicago, Ill. (West Side).	Bath, N. Y.	Atlanta, Ga. (2d.)	Chester, Pa.
Bridgeport, Conn.	Pittsburgh, Pa. (S. Side).	Lynn, Mass.	N.Y. City (Central Gas Co)	Hazleton, Pa. 2d.
Allegheny, Pa. (1st.)	Pawtucket, R. I.	New Bedford, Mass.	Lynchburg, Va. (2d.)	Novelties Exhib., Phila
St. Hyacinth, Can.	Brookline, Mass.	Waterbury, Conn.	Saylesville, R. I.	State Island, N. Y.
Norwalk, O.	Sherbrooke, Can.	Deseronto, Can.	Rondout, N. Y.	Saugerties, N. Y.
Brattleboro, V	Burlington, N. J. (2d.)	Hoosic Falls, N. Y. (2d.)	Atlantic City, N. J.	Clinton, Mass. (Lan. Mi
Waltham, Mass. (2d.)	Bridgeton, N. J.	Bethlenem, Pa.	Augusta, Ga.	Chattanooga, Tenn.
West Chester, Pa.	Bay City, Mich.	Atlanta, Ga. (1st.)	Waltham, Mass. (2);	Galveston, Texas. (3d.
Baltimore, Md.	Erfe, Pa.	Savannah, Ga.	Mahanoy City, Pa.	Omaha, Neb.

GAS COALS.

GAS ENRICHERS.

EXHAUSTERS.

JAMES D. PERKINS.

PERKINS & CO.,

F. SEAVERNS.

General Sales Agents for

The Youghioghenny River Coal Company's**OCEAN MINE YOUGHIOGHENY GAS COAL.**

The Coal from the Ocean Mine (recently operated by Messrs. W. L. Scott & Co., of Erie, Pa.,) is now used by all the leading Gas Companies in the United States from Maine to Texas, and is recognized as *the only reliable Youghioghenny Gas Coal.* (See Map on p. 87 of this Journal, Feb. 16, 1885.)

P. O. Box 3695,
New York.**PERKINS & CO., 228 and 229 N. Y. Produce Exchange.**BEAVER STREET
ENTRANCE.

BRECKENRIDGE CANNEL,

OF KENTUCKY.

This colliery was re-opened in June of the present year, and the Cannel is now being delivered to thirty of the leading Gas Companies in this country. As an enricher ONE TON of this Cannel will do the work of TWO TONS of any other available Cannel. It can be delivered in parcels of one car load or more to any point in the United States or Canada. (See AMERICAN GAS LIGHT JOURNAL, June 16, '86, pp. 346-7.)

P. O. Box 3695,
New York.**PERKINS & CO., 228 and 229 N. Y. Produce Exchange**BEAVER STREET
ENTRANCE.

JAMES & WILLIAM WOOD,

Gas and Cannel Coal Contractors,

No. 40 St. Enoch Sq., Glasgow. No. 2 Talbot Court, London.

Proprietors of the **BATHVILLE COLLIERIES** (which produce the celebrated **BOGHEAD CANNEL**), Shields, Shieldmuir, Drumpeller, and other Collieries. This Firm offer

STANDARD CANNELS,

Unequaled as Gas Enrichers.

Analyses, prices, and all further information furnished on application to

Agency for U. S., Room 93, Nos. 2 & 4 Stone St., N.Y. City.

O. J. BENHAM,
President.C. M. HIGGINS,
Secretary.L. H. SEVERANCE,
Treasurer.**The Forest City Naptha Co.,**

REFINERS OF

Red Crown Brand**NAPTHA AND GASOLINES.**

ALSO MANUFACTURERS OF

**A Special Grade of Naptha for
Gas Companies****FOR ENRICHING COAL GAS.**

Correspondence solicited.

No. 43 Euclid Avenue, Cleveland, Ohio.

To Gas Companies.We make to order **CAP BURNERS** to burn any amount under a stated pressure. Send for samples.Also, **SERVICE CLEANERS, DRIP PUMPS, and STREET MAIN PROVING APPARATUS.****C. A. GEFROERER,**

248 N. 5th Street, Phila., Pa.

The Wilbraham Gas Exhauster,

"BAKER SYSTEM,"

WITH ENGINE ATTACHED, ON SAME BED PLATE OR WITHOUT.

Best, Cheapest and Most Durable Exhauster known.

WILBRAHAM BROS.,

No. 2320 Frankford Avenue, Philadelphia, Pa.

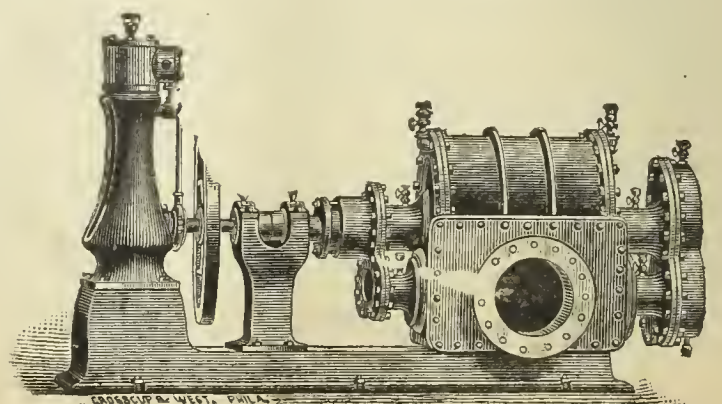

COKE CRUSHERS.

GAS COALS.

GAS COALS.

Newburgh Orrel Coal Co.,

MINERS AND SHIPPERS OF

Mountain Brook Steam and Smithing Coals,

AURORA, TYRCONNELL & PALATINE GAS COALS.

Foundry & Crushed Coke Shipped Direct from Ovens

Mines Situated at

Newburgh, Flemington & Fairmont, W.Va.

HOME OFFICE,

33 S. Gay St., Baltimore.

CHAS. MACKALL, Gen. Mangr.

CHAS. W. HAYS, Agent in New York,

Room 147, WASHINGTON BUILDING, No. 1 Broadway.

Shipping wharves at Locust Point, Baltimore.

THE DESPARD COAL COMPANY

OFFER THEIR SUPERIOR

DESPARD COAL

To Gas Light Companies and Manufacturers of Fire Clay Goods Throughout the Country.

ROUSSEL & HICKS, } AGENTS. { BANGS & HORTON,
71 Broadway, N. Y. } 16 Kilby St., Boston.

Mines in Harrison Co., West Va. Wharves, Locust Point, Balt.

Company's Office, 15 German St., Baltimore, Md.

Among the consumers of Despard Coal we name: Manhattan Gas Light Co., N. Y.; Metropolitan Gas Light Co., N. Y.; Jersey City, (N. J.) Gas Light Co.; Washington (D. C.) Gas Light Co.; Portland (Maine) Gas Light Co. Reference to them is requested.

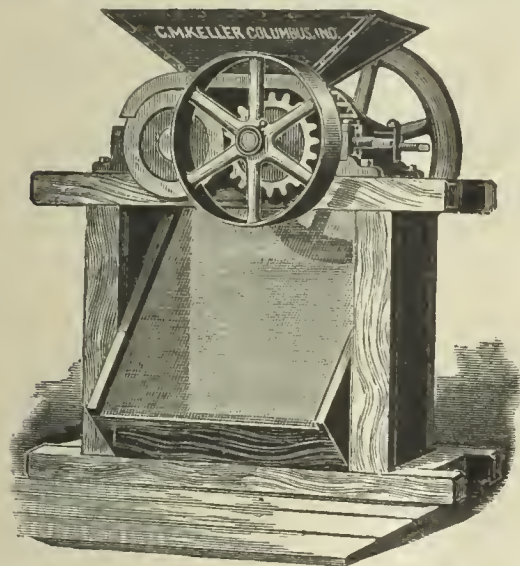

Keller's Adjustable Coke Crusher.

SIMPLE, STRONG, AND DURABLE.

C. M. Keller, Sec. & Supt. Gas Lt. & Coke Co. Columbus, Ind.

Correspondence Solicited.

GAS COMPANIES, ATTENTION!

Increase the demand for Coke by using the

Star Coke Breaker.

SIMPLE, CHEAP, DURABLE. EASILY SHARPENED BY ANY BLACKSMITH.

B. J. ALLEN, Newark Gas Co., Newark, N.J.

King's Treatise on Coal Gas.

The most complete work on Coal Gas ever published.

Three Vols. Bound, \$30.

A. M. CALLENDER & CO., 42 Pine St., N. Y.

THE PENN GAS COAL CO.

OFFER THEIR

Coal, Carefully Screened & Prepared for Gas Purposes.

Their Property is located in the Youghiogheny Coal Basin, near Irwin and Penn Stations on the Pennsylvania Railroad, and on the Youghiogheny River.

Principal Office:

209 SOUTH THIRD STREET, PHILA., PA.

Points of Shipment:

Pennsylvania Railroad Piers; Greenwich Wharves, Delaware River; Pier No. 1 (Lower Side), South Amboy, N. J.

Chesapeake & Ohio Railway Coal Agency,

FOR THE SALE OF THE

Superior Kanawha Gas Coals, Cannelton Cannel, Also, SPLINT AND STEAM COALS,

From the Kanawha and New River Regions, on the line of the Chesapeake & Ohio R'way.

C. B. ORCUTT, Sales Agent. | OFFICE, 150 BROADWAY, N. Y.

FRANCIS H. JACKSON, Prest. EDMUND H. MCCULLOUGH, V.-Prest. CHAS. F. GODSHALL, Treas. H. C. ADAMS, Sec.

THE WESTMORELAND COAL CO.

Chartered 1854.

Mines situated on the Pennsylvania and the Baltimore and Ohio Railroads, in Westmoreland County, Penn.

POINTS OF SHIPMENT:

PHILADELPHIA, BALTIMORE, SOUTH AMBOY, N. J., WATKINS (SENECA LAKE), N. Y.

Since the commencement of operations by this Company its well-known Coal has been largely used by the Gas Companies of New England and the Middle States, and its character is established as having no superior in gas giving qualities, and in freedom from sulphur and other impurities.

Principal Office, 224 South 3d St., Phila., Pa.

A. M. SCOTT, PRESIDENT. A. DEMPSTER, C.E., SECRETARY. W. K. GILLESPIE, TREASURER.

MONONGAHELA AND PETERS CREEK GAS COAL CO.,

PRODUCERS OF

Coal Bluff Gas Coal.

MINES LOCATED ON THE MONONGAHELA DIVISION OF THE PENNSYLVANIA RR. IN THE CENTRAL PORTION OF THE PITTSBURGH COAL FIELD.

Points of Shipment—Buffalo, Cleveland, Erie, Chicago, New Orleans.

Since the introduction of Coal Bluff Gas Coal it has taken rank among the few first-class Gas Coals, and acknowledges no superior in gas-giving qualities, ease of working, quality of coke, and freedom from impurities.

General Eastern Agents, ANDREW LANGDON & CO., Buffalo, N. Y.

General Western Agents, ANDREW LANGDON & CO., Chicago, Ill.

Milwaukee Agents, F. R. BUELL & CO., - - - Milwaukee, Wis.

General Office, 43 Sixth Ave., Pittsburgh, Pa.

GAS METERS.

GAS METERS.

GAS METERS.



INTERNATIONAL--1876--EXHIBITION.

The U. S. Centennial Commission

HAVE DECREED AN AWARD TO

HARRIS, GRIFFIN & CO.,

Twelfth and Brown Streets, Philadelphia, Pa. No. 49 Dey Street, N. Y. City, and No. 75 North Clinton Street, Chicago, Ill.

FOR THE FOLLOWING REASONS:

The Exhibit consists of a Series of METERS from the Largest Size Station Meters for the use of the MANUFACTURE OF GAS, to those for the use of the ORDINARY CONSUMER. The Instruments are WELL MADE, RELIABLE as to INDICATION, and embody a number of sundry improvements which, with the general character of the Exhibit, entitle the whole to commendation.

Attest—J. L. CAMPBELL,
Secretary, pro-tem.

Signed—A. T. GOSHORN,
Director General

J. R. HAWLEY,
President

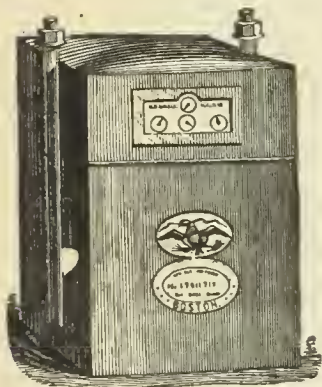

Dry Gas Meter.

With 39 years' experience and the best facilities for manufacturing, is enabled to furnish reliable work and answer orders promptly.

NATHANIEL TUFTS,*No. 153 Franklin Street, Boston, Mass.,*

MANUFACTURER OF

DRY GAS METERS.

Station Meters of any Capacity.

Test and Experimental Meters, Pressure Registers, Pressure Gauges,
Pressure and Vacuum Gauges.**METER PROVERS, PHOTOMETERS, STREET LANTERNS, ETC., ETC.**

Patent Cluster Lanterns for Street Illumination..

SCIENTIFIC BOOKS.

We are prepared to furnish to Gas Managers, and others interested in the topics treated of, the following books, at prices named:

KING'S TREATISE ON THE MANUFACTURE OF COAL GAS. Three vols.; \$10 per vol.	PRACTICAL TREATISE ON HEAT, by THOMAS BOX. Second edition. \$5.	THE GAS MANAGER IN THE LABORATORY, by a Practical Student. 8vo., Cloth. \$1.50.
GAS MANUFACTURE, by WILLIAM RICHARDS. 4to., with numerous Engravings and Plates, in Cloth binding. \$12.	GAS WORKS—THEIR ARRANGEMENT, CONSTRUCTION, PLANT, AND MACHINERY. \$8.	THE DOMESTIC USES OF COAL GAS, AS APPLIED TO LIGHTING, by W. SUGG. \$1.40.
THE GAS ANALYST'S MANUAL, by F. W. HARTLEY. \$2.50.	COAL; ITS HISTORY AND USE, by PROF. THORPE. \$3.50.	DISTILLATION OF COAL TAR AND AMMONIACAL LIQUOR by GEO. LUNGE. \$8.50.
TECHNICAL GAS ANALYSIS. \$2.80.	THE GAS WORKS OF LONDON, by COLBURN. 60 cents.	A TREATISE ON THE COMPARATIVE COMMERCIAL VALUES OF GAS COALS AND CANNELS, by D. A. GRAHAM 8vo., Cloth. \$3.
GAS MANAGER'S HANDBOOK, by THOS. NEWBIGGING. \$4.80.	THE GAS FITTER'S GUIDE, Showing the Principles and Practice of Lighting with Coal Gas, by JOHN ELDREDGE. 40 cents.	GAS AS A SOURCE OF LIGHT, HEAT, AND POWER, by C. J. R. HUMPHREYS. 10 cents.
GAS CONSUMER'S GUIDE. \$1.	GAS WORKS, AND MANUFACTURING COAL GAS, HUGHES. \$2.20.	GAS COMPANIES DIRECTORY. \$10.
A GUIDE TO GAS LIGHTING. 40 cents.	THE MANAGEMENT OF SMALL GAS WORKS, by C. J. R. HUMPHREYS. \$1.	GAS VERSUS ELECTRIC LIGHT. 50 cents.
GAS MEASUREMENT AND GAS METER TESTING, by F. W. HARTLEY. \$1.60.	MANUAL FOR GAS ENGINEERING STUDENTS, by D. LEE, 40 cents.	PURIFICATION OF COAL GAS, by R. P. SPICE. 8vo. \$8.
GAS CONSUMER'S HANDBOOK, by WILLIAM RICHARDS, C.E.; 18mo., Sewed. 20 cents.	HOW TO MANAGE GAS, by F. WILKINS. Paper. 20 cents.	
A PRACTICAL TREATISE ON GAS AND VENTILATION with Special Relation to Illuminating, Heating, and Cooking by Gas, by E. E. PERKINS. \$1.25.		

The above will be forwarded by express, upon receipt of price. We take especial pains in securing and forwarding any other Works that may be desired, upon receipt of order. All remittances should be made by check, draft, or post office money order.

A. M. CALLENDER & CO., No. 42 Pine Street, New York.**KING'S TREATISE ON COAL GAS.**

The most complete work on Coal Gas ever published. Three vols., bound \$30

A. M. CALLENDER & CO., No. 42 Pine Street, New York.

GAS METERS.

GAS METERS.

GAS METERS.

T. O. HOPPER, Pres. G. J. McGOURKEY, Vice-Pres. (New York). WM. N. MILSTED, Gen. Supt. & Treas. (New York). WM. H. DOWN Sec.

AMERICAN METER COMPANY,

WET AND DRY GAS METERS.

PRESSURE REGISTERS.

METER PROVERS.

STATION METERS.

PRESSURE & VACUUM REGISTERS.

PORTABLE TEST METERS.

EXHAUSTER GOVERNORS.

PRESSURE & VACUUM GAUGES.

EXPERIMENTAL METERS.

DRY CENTRE VALVES.

CRESSON GAS REGULATORS.

AMMONIA TEST METERS.

GOVERNORS FOR GAS WORKS.

MARSLAND WATER METERS.

BAR AND JET PHOTOMETERS.

Manufactories:

512 W. 22d St., N. Y.
Arch & 22d Sts., Phila.

GAS STOVES,

SUGG'S "STANDARD" ARGAND BURNERS,
SUGG'S ILLUMINATING POWER METER,
Wet Meters, with Lizar's "Invariable Measuring" Drum.

Agencies:

177 Elm Street, Cincinnati.
244 & 246 N. Wells Street, Chicago.
810 North Second Street, St. Louis.
122 & 124 Sutter St., San Francisco

HELME & McILHENNY,

(Successors to Harris & Brother. Established 1848.)

GAS METER MANUFACTURERS,

CONTINUE AS HERETOFORE AT THE OLD ESTABLISHMENT,

Nos. 1339 to 1349 Cherry Street, Philadelphia, Pa.,

To Manufacture Wet and Dry Gas Meters, Station Meters, Experimental Meters, Meter Provers, Center Seals, Pressure Registers

GOVERNORS, INDICATORS, PHOTOMETERS, & ALL OTHER KINDS OF APPARATUS FOR USE IN GAS WORKS.

From our long practical experience of the business, and from our personal supervision of all work, we can guarantee all orders to be executed promptly and in every respect satisfactorily.

WM. WALLACE GOODWIN, Pres. and Treas.

WM. H. MERRICK, V.-Pres.

S. L. JONES, Sec.

S. V. MERRICK, Supt.

THE GOODWIN GAS STOVE AND METER COMPANY,

Successors to W. W. GOODWIN & CO.

1012, 1014 and 1016 Filbert St., Phila., Pa.

142 Chambers St., New York.

76 Dearborn St., Chicago, Ill.

WALDO BROS., Agents, 88 Water St., Boston.

MANUFACTURERS OF THE "SUN DIAL" GAS STOVES, FOR COOKING AND HEATING PURPOSES.

Dry and Wet GAS METERS, Station Meters (Square, Cylindrical or in Staves) Glazed Meters, King's and Sugg's Experimental Meters, Lamp Post Meters, Etc., Etc., Meter Provers (sizes 2, 5 and 10 feet), Pressure Gauges of all kinds, Pressure Registers, Pressure and Vacuum Registers, Pressure Indicators (sizes 4 inch, 6 inch and 9 inch), King's Pressure and Vacuum Gauges, Dry and Wet Centre Seals, Dry and Wet Governors, Exhauster Governors, Photometers of all descriptions. Letheby's Sulphur and Ammonia Test Apparatus complete—also Testing and Chemical Apparatus of all kinds, and of the most perfect description, for all purposes relating to Gas.

GOODWIN'S IMPROVED LOWE'S JET PHOTOMETER.

Agents for Bray's Patent Gas Burners and Lanterns.

Special attention to repairs of Meters, and all apparatus connected with the business.
All work guaranteed first class in every particular, and orders filled promptly.

G. B. EDWARDS, Mang'r, New York.
E. H. B. TWINING, Mang'r, Chicago.
Represented by A. B. STANNARD.

D. McDONALD & CO.,

GAS METER MANUFACTURERS.

(Established 1854.)

51 Lancaster St., Albany, N. Y. 34 & 36 West Monroe St., Chicago, Ill.

STATION METERS, EXPERIMENTAL METERS, METER PROVERS, PRESSURE & VACUUM REGISTERS, PRESSURE GAUGES, ETC.

Also STAR GAS STOVES, RANGES, and HEATING STOVES.

We use only the very best materials, and employ the most skilled labor, and by our long experience (29 years) and personal supervision of every detail, we feel justified in assuring the public that our goods will give perfect satisfaction. Every Meter emanating from our establishment will bear the State Inspector's Badge, and will be fully warranted by us. Our Annual and Calendar will be sent to Gas Companies upon application.

GAS STOVES.

GAS STOVES.

GAS STOVES.

THE GOODWIN GAS STOVE AND METER CO.,

1012-18 Filbert St., Phila., 142 Chambers St., N. Y., 76 Dearborn St., Chicago.

Agents, WALDO BROTHERS, 88 Water Street, Boston.

WM. W. GOODWIN, PRES. & TREAS.
W. H. MERRICK, VICE-PRES.
LEWIS JONES, SEC.
SAMUEL V. MERRICK, SUPT.

SOLE MANUFACTURERS OF THE

G. B. EDWARDS, Mang'r, N. Y.
E. H. B. TWINING, Mang'r, Chicago.
Represented by A. B. STANNARD.

"SUN DIAL" GAS STOVES

The Most Economical, Efficient, and Durable Gas Stove Made.

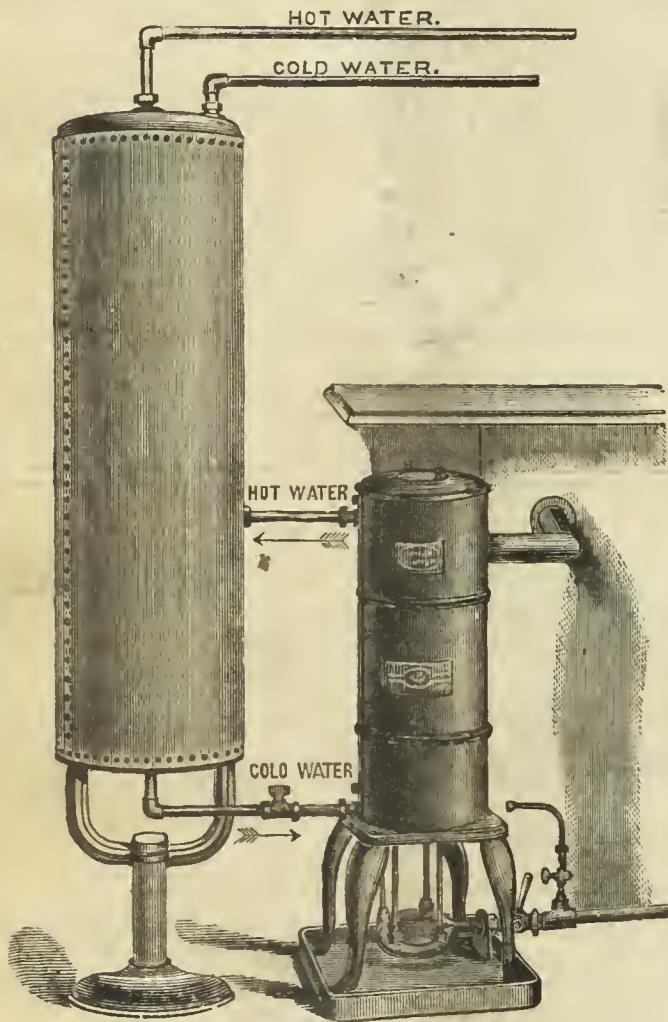

I.—Safety Hot Water Generator and Boiler.

Safety Hot Water Generator and Boiler.

Cut I. represents our Safety Gas Hot Water Generator and Boiler, arranged for home use. This most easy, quick, and economical way of preparing a warm bath, or for heating water for any domestic purpose, entirely supersedes any necessity for the use of ranges or stoves—a great comfort, particularly in hot weather. The boiler being self-filling, as the hot water is drawn off, can never become empty, thus preventing the possibility of any accident.

We beg to call attention to the cast iron pan which is now attached to the legs of the Generator (see illustration). This is to catch the drippings from the Coll, which many persons suppose come from a leak, when in fact they are produced by condensation. This condensation is caused by the hot flame coming in contact with the coil filled with cold water.



II.—Gas Cooking Stove No. 8 B.

New Style Gas Cooking Stove.

Cut II. represents our New Style Cooking Stove. As will be seen, it has an ornamented cast iron base and front, and extension shelves. The oven burner, which is atmospheric (unless otherwise ordered), is of an entirely new and improved pattern (patent applied for). The ovens are of greater capacity than those of the old style. The top, in conjunction with the outlet pipe, is designed to carry off all products of combustion; hence the outlet pipe must be connected with a flue, or the stove will not work properly.

This Stove has 4 boiling burners in top of hot plate. All fittings are nickel plated. We are making this style of Cooking Stove in the following sizes—viz., No. 7 B, No. 8 B, No. 9 B, and No. 10 B.

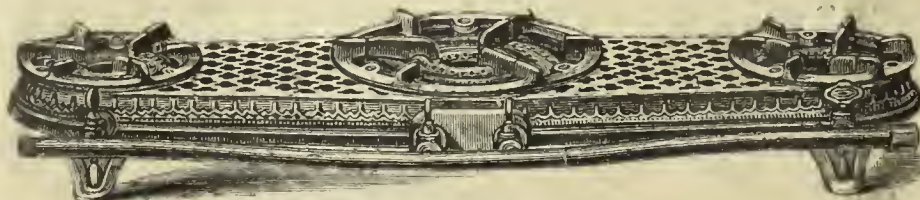

III.—Improved Hot Plate, No. 108.

New Style Hot Plates.

Cut III. represents our New Style of Hot Plates, of which we are making No. 106 (two small boiling burners), No. 107 (two medium sized boiling burners), and No. 108 (two medium and one large boiling burner). See new Catalogue and Price List for further particulars.

THE AMERICAN

GAS LIGHT JOURNAL

REDMAN & KENNY, N. Y.

PUBLISHING OFFICE No. 42 PINE STREET

DEVOTED TO THE INTERESTS OF ILLUMINATION, VENTILATION, WATER SUPPLY AND DISTRIBUTION, & GENERAL SCIENCE.

VOLUME XLVI.—No. 6.
Whole No. 666.

NEW YORK, WEDNESDAY, MARCH 16, 1887.

{ \$3 PER ANNUM,
IN ADVANCE.

A. M. CALLENDER & CO., Proprietors. C. E. SANDERSON, Manager.
JOS. R. THOMAS, C.E., Editor. T. J. CUNNINGHAM, Asst. Editor.

ENTERED AT THE POST OFFICE AT NEW YORK, N. Y.
AS SECOND CLASS MATTER.

Published on the 2d and 16th of each month, at No. 42 Pine Street, N. Y.

Terms of Subscription, Including Postage.—For the United States and Canada, \$3 per annum. European countries, \$3.50 (15 shillings—18 francs). All payments to be made in advance. Single copies, 15 cents.

Remittances should be made either by post-office order, registered letter, or bank draft on New York, payable to the order of A. M. Callender & Co.

Correspondence.—Wishing to make this JOURNAL a gazette of intelligent discussion to those of our readers who may wish to gain or give information on the subjects to which its columns are devoted, correspondence is solicited for publication from all who make the study of those subjects a pleasure or a profession.

The American News Company, Nos. 39 and 41 Chambers street, New York, are agents for this JOURNAL. Newsdealers will send orders to them.

Collections are invariably made directly from this office, for subscriptions, advertisements, etc. We have agents to solicit the same, but they are not authorized to receipt for money.

CONTENTS.

An Asterisk (*) denotes an illustrated article.

OFFICIAL NOTICE—

Western Gas Association..... 169

EDITORIALS—

Brother Littleton's Preliminary Appeals..... 169
The Baltimore (Md.) Discriminative Suit..... 170
The Ohio Association's Programme..... 170
Mr. D. D. Flemming Resigns..... 170
Briefly Told..... 170
Seventeenth Annual Meeting of the New England Association of Gas Engineers—Official Report—Concluded from page 144..... 171
Discussion on Mr. F. S. Richardson's Paper—Report of Committee on President's Address—Associate Members—Committee on Memorials—The Question Box—"What is the best way to prevent a gas main, laid across a stone culvert, from being stopped up in the winter?"—"How much coke is used, by measure, to carbonize 2,240 pounds of coal, with yield per pound?"—"Can a gas company afford to devote its attention to electric lighting?"—Remarks of Mr. Page—Votes of Thanks—Report of Committee on Memorials.
Mr. T. Fletcher's Lecture on Curious Gas Flames..... 180
The Velsbach Incandescent Gas Burner..... 181
Mr. A. F. Upton Discusses Combustion..... 181
Notes from the West, by "Retort"..... 182
Proving or Testing Meters..... 182

ITEMS OF INTEREST FROM VARIOUS LOCALITIES..... 183

The Proprietors of the Shaner Gas Coal Company—Destruction of an Electric Light Station—The Pawtucket (R. I.) Folks will Try it—To Burn all Night—To Erect a Holder—Mr. Attrill would Rather Not—The New York City Subways—The Weher Furnaces—Bermuda's Pleasant Breezes—Enlarging its Possessions—Grand Forks (Dak.) Ought to be Satisfied—To Leave Nebraska City, Neb.—To Furnish Electric Light—Retorts for the Quaker City Gas Works—Financial Standing of the Middletown (Ohio) Gas Company—They Want to See the Books—Street Lighting at Circleville, Ohio—Lowell's Cheap Gas—At Last it is Settled—Managers of the Albany (N. Y.) Edison Company—In Charge of the Fulton-Municipal Works—Changing the Buffalo (N. Y.) Method of Street Lamp Assessment—A Handsome Structure—Deacon Ober-glock Did not Believe in Gas Meters—Increasing the Capital Stock—Swapping Gas Stock for a Race Track—Making it Larger—Chicago's Public Lighting Ordinance—One of the Possible "Snags" in the Joint Proposition—Visalia (Cal.) to Have Light—It Failed to Pass the Lower Branch—To Recover Damages—Talking of a Rival Gas Company in Manchester, N. H.—Notice of Removal—Annual Meeting, Boston (Mass.) Gas Light Company—Death of Mr. James H. Walker, Sr.

A Substitute for Coal..... 185
The Market for Gas Securities..... 186

[OFFICIAL NOTICE.]

Western Gas Association.

SECRETARY'S OFFICE, QUINCY, ILL., March 9, 1887.

The Tenth Annual Meeting of the Western Gas Association will be held at St. Louis, Mo., on the 11th, 12th, and 13th days of May. The Southern Hotel has been selected by the Committee of Arrangements for our abiding place, and the choice cannot fail to meet with the hearty approval of our members. With regard to a hall for our business sessions, it has been thought best to inaugurate a departure from our old-time custom of accepting (simply because it was "handy") any vacant room in the hotel building which might be placed at our disposal. Those who remember our unfortunate experience in St. Louis, three years ago, will, I am confident, give the new experiment an unqualified indorsement. A hall admirably suited to our requirements, on the corner of Sixth and Walnut streets, just one block from the Southern, has been secured by our diligent Committee, and when the hour for assembling arrives our members will applaud the selection as a most happy one. That the acoustic properties are admirable has been repeatedly demonstrated, while the size, location, and facilities of all kinds are faultless.

In the matter of securing reduced railway rates, I have no information that is particularly satisfactory or encouraging to offer. I am in receipt, however, of the following communication, which will explain itself. It is to be hoped that the vexed question referred to may be settled in our favor in time for us to derive some benefit from the decision.

CENTRAL TRAFFIC ASSOCIATION, PASSENGER DEPARTMENT, }
OFFICE ASST. COMMISSIONER, CHICAGO, ILL., Feb. 16, 1887. }

A. W. LITTLETON, Esq., Sec. Western Gas Association, Quincy, Ill.:

Dear Sir—Replying to your favor of the 14th inst., requesting reduced rates for delegates attending the Western Gas Association's annual meeting at St. Louis, on the 11th of May, I beg to say that, owing to the uncertainty as to what will be the rulings of the commission and the courts regarding reduced rates for societies, conventions, etc., under the Inter-State Commerce Law, this Association has decided not to make any further reduced rates for societies until some competent and definite interpretation of the law can be had, as it is the desire of the lines in this Association to conform to the spirit of the said law, and in no case to wilfully violate it. Further action on your application has therefore been deferred until the interpretation or ruling above referred to can be had.

Very respectfully yours,
GEO. H. DANIELS.

Your Secretary is becoming a little uneasy for fear that a sufficient number of our members may not give favorable consideration to his request for papers. I hope that there may be no disappointment in this particular, but that a goodly number of our talented members (and we have scores of them) may put their shoulders to the wheel, or rather their pens to paper, and oblige us with their contributions.

A. W. LITTLETON, Secretary.

BROTHER LITTLETON'S PRELIMINARY APPEALS.

The members of the fraternity have ample cause to know that a gas man's lot is not a happy one, despite the fact that the average or everyday citizen stoutly maintains to the contrary. In fact the latter party often goes upon the record as saying that no other billet can compare, in the matters of ease,

snugness, and wealthiness, with that enjoyed by the lucky gas maker. The trouble is that the average citizen does not discriminate properly; in fact he rarely condescends to give expression to other than "glittering generalities," deeming those that are ornately fringed with vituperation as best fitted to give expression to his well-founded(?) convictions. Now, did he say that an occasional director, who, reclining at ease in peaceful repose, in the declining years of a "well-spent life," calmly receives his dividend checks—the fruition of canny investments in the early days of gas development—enjoyed a "happy lot," he might be measurably near the truth. Still, the "occasional reclining director" is liable at any moment to have his elydic visions ended by the rude hands of the gentlemen who are ever on the alert to start up an opposition gas company. The opposition can best be warded off by the patient and sagacious management of the executive officers, who save the "occasional director" to his ease only by dint of hard fighting in the local council boards, and often in the more extended arena of the State Legislature; not forgetting the continual conflict at home with the indignant consumer. And when we come to the "happy lot" of the engineer and superintendent; what a veritable bed of roses he enjoys! The "nagging" of his board; the struggle (without credit or renown) with the district assemblies, and the seemingly ubiquitous "walking delegate;" the delays of contractors; the freaks of the weather; the capriciousness of the product which he manufactures; the importunities of the inventors of and the agents for the sale of patent rights! Roses hardly express the situation; indeed thorns would seem to be about the proper thing to say. Now, adding to all these rueful items the plain fact that a brother engineer is elected to assume the Secretaryship of an Association of his fellows, how greatly aggravated is his lot. It, therefore, becomes the duty of his co-laborers to smooth, as best they may, the ruggedness of his pathway; and we respectfully submit that no other better attempt at amelioration can be vouchsafed him than by paying heed to his admonitions.

In Brother Littleton's second official announcement regarding the forthcoming Tenth annual gathering of the Western Association, at St. Louis, and less than two months separated from us by the calendar, we note he writes himself as "becoming a trifle uneasy for fear that a sufficient number of our members may not give favorable consideration to his request for papers." Now, this is not as it should be, and we have not the slightest doubt that the developments of the next 30 days will banish all fear in that respect from the cranium of the worthy Secretary of the Western Association. We will add that the recent sessions of the New England Association were most valuable to the industry, and made so by the papers read thereat. Neither hairsplitting nor verbosity characterized the literary productions; nor do we find that learned disquisitions on abstruse topics were presented for digestion. No; a common-sense and practical treatment of the questions dilated upon gave them that zest so valuable as an aid to keen appreciation. The Western Association members must not let others wrest from them the palm for good work in the technical field, and will therefore set at work with a will to keep themselves in the foremost rank. Littleton will not mind how groundless you may make his fears prove to be; in fact we surmise that the more completely you dissipate them the broader will be the smile of satisfaction that will play over his face. The only possible cause for danger in this instance would seem to lie in the direction that individuals may say to themselves, what is the need for me to present a paper when so many others are sure to be on hand? Even if vigilance be the price of success, better be vigilant and successful than to allow inertia to cause your defeat. One other item in Brother Littleton's current notice seems to call for comment, and that is in regard to the reply received from the Assistant Commissioner of the Central Traffic Association. We notice that the railway officials are in great accord in their desire not to infringe upon the tenets of the Interstate Commerce Law—more particularly so when those tenets refer to cheap railway fares. If they will only pay equal heed to some of its other provisions, the Hon. Mr. Reagan, of Texas, will receive the true homage of a grateful people!

THE BALTIMORE (MD.) DISCRIMINATIVE SUIT.

Some time since a suit was brought in the Circuit Court for the Baltimore district, nominally by Mr. Anthony Swarz, but really on behalf of some 7,000 gas consumers of Baltimore, who sought to have the practice of charging discriminative rates for gas, by the Consolidated Gas Light Company, declared unlawful. As the majority of our readers are aware the companies supplying gas in Baltimore are engaged in a war of competition. The Consolidated Company's mains reach all districts of the city; but those of its competitor are not so extensive. In sections piped by both companies the consumers are supplied at a charge of 50 cents per thousand cubic feet, while those entirely dependent for a supply on the Consolidated Company are charged \$1 per thousand. Some time since the case was argued on its merits before Judge J. Upshur Dennis, in the Court above noted; and after due deliberation the learned gentleman announced his decision, which disallowed

the claim of plaintiffs, on the broad ground that no injury had been done them. The case is of such importance that we deem it proper to give the following resume of the decision, as forwarded us by our Baltimore correspondent, who, having noted that Mr. Samuel Snowden represented the plaintiffs, Messrs. I. Nevett Steele, and J. Alexander Preston acting for the Company, says:

Judge Dennis said three questions were involved: "First, is the respondent company a corporation of such a character that its rules and regulations are subject to supervision and control by the courts? Second, if it is, is the discrimination complained of such that the court will declare it void on the ground of public policy? And third, have the complainants mistaken their remedy by proceeding in this Court?" On the first point he held that the case comes within the operation of the principle of State control of corporations; that the company is engaged in public employment, and must submit to public control. On the question whether the discrimination complained of in the bill is of such a character that the court must declare the rule of the company which prescribes it unjust and unreasonable, and therefore void, Judge Dennis said the "extent to which the control by the State of corporations of this quasi-public character goes is well defined. In many States acts of the Legislature have fixed it, but it has always been held that these acts were simply declaratory of the common law, and that in the absence of statutory enactments the power existed to its full extent in the courts, and the limits of that power confine us to determining whether the rules or regulations which are brought in question are *reasonable* and *just*. Further than that the courts cannot go. They have no right to interfere with the purely private concerns of the corporation, or with any methods of business it may choose to adopt, provided no *wrong* is done to the complainants thereby.

"The complainants themselves, however, admit that the price charged for gas is less than it is furnished for in any other city, and is a reasonable price. The residents in the non-competitive district have no right to complain (so long as the charge made to them is reasonable) because the residents in the competitive districts have their gas furnished at a lower rate. Suppose the court should decide that the company must charge all alike—the \$1 per thousand feet. The complainants would receive no benefit, but the residents of the competitive districts would be made to suffer. And how can the court be asked to direct that the company shall make the charge of fifty cents per thousand feet uniform, when the agreement of facts admits that the actual cost to the company of the manufacture of gas is more than fifty cents? Such a decree would be practically confiscation of the company's property. Taking this view of the case it is unnecessary to consider the question as to the proper remedy for the complainants."

THE OHIO ASSOCIATION'S PROGRAMME.

We are in receipt of the programme for the sessions of the Ohio Association, whose members inaugurate their Third Annual Meeting at the Beckel House, in Dayton, to-day. Five sessions are arranged for, one evening assembly to take place at 7:30 o'clock this evening. Including President McMillin's inaugural address fourteen specially prepared papers are to be read, each of which will treat on a subject of interest and importance. An examination of the Secretary's final announcement admits of but one conclusion, which is that the lusty Ohio Association has prepared itself with care for a meeting in all respects calculated to outdo its former efforts, and the latter were entertaining in a high degree.

Mr. Dudley D. Flemming Resigns.

One peculiarity connected with the management of the United Gas Improvement Company seems to be its unwillingness to retain in its service those who evince a predilection to think for themselves. Slavish obedience to the snap of the whip constitutes virtue in the sight of the Company's controllers. The latest instance of the "nagging" process adopted by the Jersey City branch of the confederation is furnished in the resignation of Mr. Dudley D. Flemming, who retires from the service of a Company that he has faithfully served for many years.

COLONEL BENSON, the gallant Engineer of the Nassau Gas Light Company, of Brooklyn, N. Y., is once more at his post. His trip to Europe was of great benefit to him in every way.

THE Cable bill "to punish fraudulent practices by officials of gas companies," was defeated, on the afternoon of March 8th, in the Ohio House of Assembly, by a vote of 4 for to 72 against.

THE Yonkers, Municipal and Westchester Gas Light Companies, of Yonkers, N. Y., having entered the fold of the United Gas Improvement Company, the erstwhile happy gas consumers of that locality have been informed that from and after April 1st they will be obliged to pay \$1.75 per thousand cubic feet for gas supplied them.

[OFFICIAL REPORT.—Concluded from page 144.]

Seventeenth Annual Meeting of the New England Association of Gas Engineers.

HELD AT YOUNG'S HOTEL, BOSTON, MASS., FEB. 16 AND 17, 1887.

SECOND DAY—THURSDAY, FEB. 17.—MORNING SESSION.

*Discussion on Mr. F. S. Richardson's Paper.**

The President—Without having had any intimation of the contents of the paper, I think the remarks made when introducing Mr. Richardson were fully warranted by the facts which he has presented to us. I think it is one of the most, if not the most, interesting papers that we have heard read at this meeting. Its facts and figures come right home to all of us. We all have been putting forth our best efforts to produce a good quality of gas, and to sell it for illumination to the best advantage, and in a way to compete with every other light. I trust the paper will be thoroughly discussed by the members. I am sure Mr. Richardson will be glad to answer any questions that anyone may wish to ask him. I hope that those who have had experience in this direction will state it, and that those who have advice to give will give it.

Mr. Stiness—I am much pleased that another of our young men has entered the field of high candle power burners, and proposes to occupy it. I have had considerable experience with the Lungren burner, and it is identical with the experience of Mr. Richardson. I could not state it in language more accurate than our young friend from North Adams has done. I have, I think, gone a little further than he has done, for I put the Lungren burner in direct competition with an arc light, and it was afterwards stated by the business men of Pawtucket that either the arc light was not of 1,200 candle-power, or else the Lungren burner developed a duty far in excess of what I claimed for it. We have had, during the past few weeks, a "Mechanics' Exhibit" at Pawtucket. You know we have in our city a great diversity of manufacturers. For instance, the Conant Thread Company; the Slater Cotton Company, engaged in the manufacture of the very finest grades of lawns and shirtings; the Dunnel Manufacturing Company, manufacturers of curtain materials and prints; the Loraine Company, which makes a specialty of the very finest grade of dress goods; and D. Goff & Son, now the exclusive manufacturers of fine plush in this country. The exhibition above referred to was intended to display the goods of these and other manufacturers, and they desired to have the exhibition hall well lighted. The hall (it was larger than this room) originally contained two 6-light chandeliers. On the morning of the day fixed for the opening the managers came to me and said that on the night previous (when the goods to be displayed had been properly grouped) they did not have enough light. Tiers had been built up for the purpose of showing the various goods; and, of course, the tiers obstructed the light somewhat. Dark corners had been created. I immediately telegraphed to Philadelphia for two of the 16-candle power Lungren burners, and the following Sunday the reporter of the *Providence Journal*, in his report or description of the "Mechanics' Exhibit" (it was visited by 3,000 people, so you may judge it was of merit), said that "the enjoyment of the exhibit of manufactures is greatly enhanced by the magnificent light from the Siemens-Lungren regenerative gas burner furnished by the Pawtucket Gas Company." I consider that to be one of the very best encomiums that could be pronounced upon the lamp. It was entirely honest, unsought and unbought; and, further, it was the universally-expressed opinion of all those present that the room was splendidly lighted. In one of the rooms of the Business Men's Association (an association composed of 200 of the leading business men of our city) I have had, for many weeks, a 12-foot Lungren burner. It has received universal commendation. One has also been so placed in a store that you might say it was almost out of doors, for but a small portion of the store had any surrounding wall. They had used previously an arc light, but in its place we put a 16-foot Lungren burner, and the proprietor was decidedly of the opinion that to him the light was far more pleasing than that formerly given by the arc light. From the nature of the goods sold (it is a butter shop) the proprietor was a little afraid that during the summer the amount of heat generated from the burner would be a disadvantage. While I am ready to agree with Mr. Richardson that the price of the lamp at the present time may be considered a little high; yet, in my individual case, in several instances where I put them in, I have said to the parties, "If you want the burner it is yours to try; after you have used it a sufficient time to determine its merits, and then desire to purchase it, you can do so." In one case a storekeeper who had a very handsome chandelier in his place, said, "I dislike to take that down and throw it away." I replied, "I will exchange this burner for your chandelier." I know, from what he told me lately, that rather than have the burner taken down he would give away his chandelier and buy a Lungren. Such is the policy, I think, gas companies must pursue. The electric light people are pressing so hard

and strong upon gas companies that the promoters will go into a shop, string their lights, and make no charge for the work. To many people that is quite an inducement to put in the incandescent light. All they have to pay is a fixed charge per month for the light. The incandescent consumer has not to pay for fixtures; in fact, he pays for nothing but the light. As said by me very many times, I think it is the true policy of gas companies to get out of the old ruts in which they have traveled, and get into new paths. They should assist in all ways and means to encourage the consumption of gas. I was rather pleased that Mr. Richardson also touched upon the subject of electric lighting. I have always maintained that that subject has never received from the New England Association of Gas Engineers the attention which its importance and merit demanded. The two systems of lighting can be and should be brought under one organization. As is well known to you I have always maintained that the title of "Gas Company" should be changed to that of "Artificial Light Company." It makes no difference to me which light I supply. If a consumer wants gas I furnish it; if he wants the electric light I give it to him. I think the subject is worthy the serious attention which Mr. Richardson's paper asks for it. I believe we should do all we can to increase our business, and strengthen the companies we represent, by urging the adoption of these improved burners—and also by the introduction and supply of any system of artificial lighting that the public demand. I submit that no one will dispute that at the present time the public do demand electric lighting.

Mr. Allyn—In Cambridge we are now introducing the Lungren light, and I desire to get what information I can from those who know more about it. I would like to inquire of Mr. Richardson whether it is the practice among those using the light to extinguish it or merely to turn it down to a glimmer, and allow it to so burn during the daytime. I find there seems to be a difference of opinion with regard to the best method. I believe that the almost universal practice in Hartford is to leave it burning in a slight glimmer during the daytime. I find that some are a little skeptical as to the amount of gas consumed during, say, the 15 or 18 hours when the light is turned down.

Mr. Richardson—I will say, in reply, that only three of our fifty odd lights are left burning with a glimmer. I think possibly if we were able to approach so near the dollar mark as our friend from Hartford has done I should recommend that all be left to burn with a glimmer; but excepting those which are burning in the hotel, and in the National Bank, I have recommended that they be set with a complete shut off; and I must say they light very easily. It is a fact that before placing them outside of the gas company's control every lamp should be kept burning in the office at least two days—unless you are pressed for their use—because the parts seem to yield quicker to the flame after they have been thus burned. The flame then spreads itself about the flame-plate without any delay, and you do not perceive the disagreeable odor that comes from the lamp when it is first lighted. I make it a practice to test the lamp on a test meter, and to burn it one or two nights before sending it out. I would recommend, save in exceptional cases, that they be not left burning.

Mr. Allyn—I am very much obliged to Mr. Richardson for his suggestion with regard to operating the lamps in the works before sending them out. I think it is an excellent plan, and overcomes one of the two objections made to this lamp. In every case where we have put up a Lungren burner the odor thrown out when the light is first started has been spoken of as objectionable; and we have been asked whether it is the general practice of the lamp to throw out such a smell. Of course, we always explain that it is caused by the new metal being heated up, and that it passes off in a short time. The other objection seems to be the difficulty experienced by some in lighting the burner. Considerable knack is required in lighting up one, especially when at a high elevation from the floor; but with a little experience this is overcome.

Mr. Richardson—When the lamp has been used for a short time they light very much easier than at first.

Mr. Stiness—Mayor Sayles, of our city, a member of the Business Men's Association, owns a very elegant mansion, and after I had operated that lamp in the rooms of the Association for a few days he said he wanted me to put one of those lamps in his hallway, provided it could be lighted by electricity, as every burner in his house is lighted in that way. I immediately entered into correspondence with the Siemens-Lungren Company on the subject, and they are now experimenting to see if the plan is a practicable one. The trustees of a large church in our city desired to put up four of the lamps, but they are placed at such an altitude that they must be lit by electricity. If the Company succeeds in the experiment it will be a very great help in introducing the burners. I hope they will succeed, for I consider there is a great field and a great future for that Company, for the gas companies, and for the public, in the introduction and use of the Lungren lamp.

Mr. Richardson—The fact stated by my paper with regard to our success in introducing the lamp is, I think, quite important. A large part of the North Adams gas consumption is in the mills, for the business portion of our city is not very extensive. We have a local electric lighting company

* For paper, see issue March 2, p. 143.

that is owed by the merchants (at least the portion I do not own myself), and they all use the light which they believe to be theirs. That, of course, takes from us a number of stores, many of which would otherwise use gas. Now, 50 or 55 Lungren lamps means, with us, a great deal when compared with the size of our town. We do not sell over sixteen million feet per annum, consequently the number of lamps that I have succeeded in selling is noteworthy. I have adopted the same plan of introducing them suggested by Mr. Stiness—that is, I hang the lamp, and if its working is satisfactory to the consumer he buys it. I think that is the only, or rather the best, way to force the lamp into use. When you get one or two hung in a small or a large room you may feel sure that they will never be taken out.

The President—Has Mr. Wood, of Syracuse, N. Y., had any experience with the Lungren lamp?

Mr. Wood—About as the gentlemen have related. The great difficulty I have experienced in introducing them is their cost. We have put in a dozen or fifteen, and these have given the best of satisfaction in every respect, except as to price.

Mr. Copp—I am sorry that Mr. Bill is not here to state what has been done at Malden; but as I am connected with the Company I will relate the results in connection with the subject under discussion. An electric light company visited Malden and canvassed for business. We welcomed them, for we knew they would be an incentive to the use of gas. The business community of Malden is not an extensive one, and the trade done is of a small retail nature. Up to the advent of the electricians the shopkeepers did not favor gas to any extent, for perhaps but eight or ten of the thirty or forty merchants used it in their stores. We were satisfied we had to do something to extend the use of gas; and to do so and to compete with electricity we introduced the Lungren burner. We have now about 100 Lungrens, varying in size from 8 to 16 feet per hour, in use. We have adopted the system of putting them in on rental. Our original idea was to put them in free, because the electric light was furnished without any rental charge for the lamp. The first man approached on the subject wanted to know what the Lungren lamp would cost him, and we made the rental charge equal to 50 cents per quarter. He was satisfied, and that has been established as the price. We placed them in a large number of stores, and have sold six or eight for use in private dwellings; but in no instance have we sold any of them to storekeepers, or those whom we might term commercial users. The lights have, as a general thing, given good satisfaction. We have had little or no complaint from the heat, and hardly any complaints from the lights. At Rockland, Me., we have a Lungren employed as a street lamp. The only trouble there is that the burner is too long to fit the lantern, which brings the flame too near the bottom of the lantern frame. So far as its use in that capacity is concerned it burns quite as perfectly on the street as it would in a room. We are perfectly satisfied with the introduction of the lamp in Malden. Many arc lights that had been put in stores have been displaced by Lungren lamps. In fact we found the Lungren burner to be a very excellent competitor with electricity, and while we have no desire to crush out the electric light company in Malden, we are very glad to take away from them all the business we can.

The President—I understand that Mr. Slater has had some experience with the Lungren lamps in Providence. Perhaps he would give us the benefit of that experience.

Mr. Slater—We have but a few Lungren lamps in use in Providence. The first were put up in the Post Office, which building was formerly lighted (I think for eighteen months), by Weston incandescent lamps, charged for at a very low rate. The incandescent light was originally put in under certain influences. At the end of about eighteen months, the Collector, (who is the custodian of the building for the Government), was replaced by a new official. At the termination of the original incandescent electric lighting contract, the company that had it proposed to raise the price, in fact, to double it. Proposals for lighting the building were invited; the Providence Gas Company put in a proposition, offering to furnish the Lungren lamps. We showed them to the Collector, who was very much pleased at the system, as also were the Post Office officials. The affair terminated in our securing the contract to light the building. In the first place, under the former plan, the space known as the "Lobby," formerly had seven two-burner pendants, each burner consuming six feet, or a total consumption per hour of eighty-four feet; and these, under the new system, were displaced by seven Lungren lamps of different sizes, varying according to the area to be lighted. These consumed ten or twelve feet per hour less than the quantity formerly taken up by the fourteen burners, and light the place very much better than it has ever been lighted before. A few weeks ago, one of our electric light companies was burned out, and for a few days could not supply any light. One of our consumers, who had been a large user of the incandescent light, came to us to know if we had any of those Lungrens. We told him we had five in the office at the time. He said he would like to have them put right up, and to send the bill in with them—he had seen the lamps burning in the Post Office. We put them up, and after two days he sent to

us for two more of larger size. We put in four more, of large size, and he is using them still, although the electric light company has for some time been in condition to again supply the demands of consumers. We have also put them in in one or two other instances, which constitutes all the experience we have had so far with these lamps.

The President—Does Mr. Slater remember how many incandescent lights there were in the Post Office altogether?

Mr. Slater—No, I do not. In the working portion of the Post Office they still use the common flat flame burner.

Mr. Coffin—In the Business Men's room in Gloucester, we put up a 16-foot Lungren burner, which took the place of a four-light chandelier, and two Argand drop-lights. It suited the public and the patrons of the room so well that it attracted a good deal of attention. The agent of the electric light company claimed, so I was told, that it was an incandescent lamp.

Mr. Richardson—The suggestion made by Mr. Copp is a very important one to companies that have a surplus of money. A few thousand dollars can be put to no better use than in buying Lungren lamps, and renting them. Even if you cannot get more than fifty cents per quarter for their use, that figure will net you ten per cent. on the cost, while \$1 per quarter will net you twenty per cent. You will make money on your investment, and the sales of gas will be doubled. I know of no better way in which a company can invest its surplus than to use a part of it in buying and renting Lungren lamps.

Mr. Nettleton—I would emphasize the point made by Mr. Copp, and reiterated by Mr. Richardson. It seems to me that with so expensive a burner as the Lungren, it will be often impossible to get people to try it, except we show our willingness to put our money in it. I think the companies that ask the people to buy it outright, and who are unwilling to furnish it on trial, will make very slow progress in its introduction. On the other hand, if we will only imitate the electric light companies who go to a man and say, "Won't you have the electric light? we will put you in the wires and the lamps; we will see that the lamps are kept cleaned; we will furnish and put in the carbons as required, and we will do everything needed for so much per year." I have tried during the past two months to introduce them in towns that I supply with gas, by offering to sell them at cost, or to rent them at \$3 per year. So far I have met with fair success. I have now over thirty in use, and I shall be disappointed if, before the end of the year, the number is not materially increased.

Mr. Taber—It seems to me that the Lungren lamps will aid us to solve one problem that has hitherto been a bugbear in our business. The electric light companies are able to take a contract for supplying a store, an office or a house with light, at so much per year. Hitherto we have been unable to contract on any such terms. We sell our gas by the meter, at so much per thousand cubic feet. It seems to me it is possible, with this Lungren lamp, to know the maximum consumption, to estimate the number of hours which any one will use the lamp, and thus be able to meet the electric light companies on the same kind of contract system. In a case in New Bedford, where we tried to introduce one the other day, I made an offer to light a store for a little less than the electric incandescent supply would cost. In making the offer, I was perfectly sure that if it were accepted I should be selling the gas a little higher than our regular rates—taking as fair, the statement of the merchant about the hours that he would use the light. It seems to me by means of these lamps we can compete with the contract system of the electric light companies.

Mr. Stiness—Have we the same means of shutting off the light that the electric light companies possess?

Mr. Coggeshall—I have had some experience with the contract system. There is a store in my town in which there had been six arc lights. They said they would burn gas if they could make a contract for a certain definite sum of money. They agreed to burn the light only a certain number of hours, and I agreed to light the store for a certain sum. During the past winter, on several cold days, I have passed that store when every light was going. I had my inspector visit that place for six days, in order to see how much was the day consumption, and he found they consumed a thousand feet each day.

Mr. Todd—I represent a very small company—the Natick. I put in some of those Lungren lamps about a year ago. The electric light people told most of the gas consumers that the electric light was much cheaper than gas—the price of our gas is \$2.85. I figured out what it would cost to run the Lungren lamps during the hours in which the different stores were kept open. I found, for instance, one store would average during the year about four hours per night, for six nights each week; another would average three hours per night; some others would average but two and one-half hours per night, on five nights per week. I sent to each of those consumers a statement of just what it ought to cost them to operate the lamps for a year, at \$2.85 per thousand cubic feet for the gas. A 100-candle power lamp, using eight feet per hour, three hours per night, six nights per week, would in a year burn 7,488 cubic feet of gas, which at \$2.85 per thousand made the an-

nual expense foot up \$21.33. A 150-candle power lamp burning twelve feet per hour, would cost \$32 per year; and a 200-candle power lamp \$42 per year. I rent the lamps at \$4 per year. The lamps cost us delivered, including freight charges from Philadelphia, \$24.50 each. To those who wished to buy, rather than carry so many lamps we threw off the \$4.50 and sold them for \$20. We have ten in use now, and one or two more are ordered. The local electric light company finds its business pressed pretty hard, I am afraid rather too hard for its own good. The electric light company when starting in attempted to persuade our consumers that, for the interest of the public, they should patronize the new light, and a number of them did so. They were obliged to contract to take the light for a year, which period, in a number of instances, terminates on April 1st. To show what may be the outcome, I may say I have orders now on hand to put in two or three Lungren lamps, in place of as many electric lights when the contracts for the latter terminate, and I believe that we shall have a few more like orders before the 1st of April.

Mr. Prichard—I wish to say a word (which is brought to my mind by Mr. Stiness's remarks in regard to the use of the electric light in a butter store) about the nature or quality of the light from the Lungren lamp. My idea is that the Lungren lamp light is just white enough to be particularly economical. It furnishes rays of the precise colors best adapted to light the interior of a room. In looking around a room so lighted you will probably find that the prevailing colors are white and red, or the lower rays of the spectrum, and that there are but very few of the upper, or bluish rays, so prominent in situations where the arc light is employed. The result of all this ought to be, theoretically, that the butter merchant who lights his store with a Lungren lamp will have brought out in strong relief the rich yellow of the butter, and thus may make it look 10 cents per pound better than it did when it was displayed by the agency of the arc. And it is just so with any interior. The arc light may furnish like volumes of yellow and red rays; but it will also develop a proportion of blue and indigo rays so far in excess that the latter overshadow the red rays, thus producing an unnatural effect. I think the Lungren burner just fills the requisite of economy in illumination that I tried to portray in my paper.

On motion of Mr. Nettleton the thanks of the Association were voted to Mr. Richardson.

REPORT OF COMMITTEE ON PRESIDENT'S ADDRESS.

Mr. Stedman, from the Committee on President's Address, read the following report:

The Committee to whom was referred the President's address beg to report that the particular point requiring action on the part of the Association is the recommendation in regard to creating a class of Associate Members. The Committee unanimously approve the action so recommended, and advise the adoption of an additional article to the Constitution authorizing this Association to elect Associate Members, and defining the status of such members when elected.

They further recommend that a committee be appointed to prepare the necessary additional article to the Constitution, and to present the same in time for action at the next annual meeting. Also, that the same committee be requested to prepare amendments to any articles of the Constitution which, in their opinion, may be improved in explicitness and clearness of meaning by such amendments, and submit the same as above.

For the Committee,

W. A. STEDMAN, Chairman.

Mr. Stedman, in addition to the formal report as above, said: The Committee have particular reference, in that recommendation, to Article XIII. of the Constitution, which defines the way in which its provisions may be amended or altered. That article reads as follows:

"These articles may be altered or amended at any annual meeting, notice of such proposed change having been given at least one fortnight previous to such meeting."

The article does not define to whom or in what manner such notice shall be given; therefore it was thought by the Committee desirable make it more definite, especially as, on a previous occasion, there was a little hitch in making a proposed amendment, in consequence of notice not having been given to the members. Therefore the Committee recommend the insertion of a clause defining when notice shall be given, how it shall be given, and to whom it shall be sent.

Mr. Taber—I move the report be accepted, the recommendations of the Committee adopted, and that the committee be appointed by the Chair. (Agreed to.)

APPOINTMENT OF THE COMMITTEE.

The President—I will appoint on that committee Col. Stedman, Mr. F. C. Sherman, and Mr. D. W. Crafts. I would suggest to the committee that their report be prepared at least 30 days before the next annual meeting, and forwarded to the Secretary, so that he may print and mail a copy of it to each member of the Association, in order that they may know just what

amendments to the Constitution are proposed, and that when we come together next year we may be prepared to take action thereon. If the committee will accept the suggestion, and bear it in mind, I think it will facilitate matters at that time.

ASSOCIATE MEMBERS.

Mr. Taber—If this amendment to the Constitution is adopted at the next annual meeting would we be able, at that meeting, to elect associate members?

The President—The opinion of the Chair would be, if the report of the Committee be accepted, and such amendment be adopted by vote of this Association, that gentlemen who might then apply for election as associate members, if approved by the Board of Directors, could be admitted at the next meeting.

Mr. Cabot—A gentleman from Rhode Island spoke last evening about the importance of having the directors of gas companies present at our meetings, and the suggestion seemed to me to be very appropriate. I do not think the directors of our corporations are as familiar with the details of gas manufacturing as they should be. Perhaps some of them are as familiar with the details as they want to be; still I think, if they could be induced to attend our meetings, they would be very much interested, and they would also discover how important it is for their agents to be in attendance at these gatherings. If there is any way in which that could be brought about either by an invitation given to them to be present at our discussions, or through some arrangement by which the corporations could become members, and send one or two delegates to our meeting, I think it desirable that it should be done. Perhaps the directors themselves might not want to become members, but they might be desirous of appointing some one of their number a representative to be present at our sessions. In such event they would become more interested in our proceedings than they now are, although I think we have made a great deal of an advance in that direction in the last five or ten years. There was a time when the directors thought it was merely for a "jollification" that the members of this Association held their annual meetings in Boston; and a good many of them rather regretted we took that opportunity to leave our business. I think something may be done by which we can reach those gentlemen, and induce them to be present at our meetings, and I feel that such attendance would be useful not only to them but also to their agents. I make the suggestion while this matter from the committee is before us, hoping that someone may propose the means for carrying it out.

The President—I think Mr. Cabot's suggestion is well made. Personally I have no doubt at all but that if the directors of gas companies were more familiar with the doings of the Association they would perhaps have more confidence in the advantages to be derived by the managers of gas companies who attend the meetings. I have personally tried to interest the members of the Hartford Company's board of direction in the matter, and have done it in this way. Two or three years ago I sent a check to the publishers of the AMERICAN GAS LIGHT JOURNAL, in New York, directing that a copy of the paper be mailed to each member of the board of direction. I have kept up that custom of having them supplied with the paper, and have invited some of the gentlemen to attend this meeting. Unfortunately they could not come. I think there are two ways in which they can be reached—either by invitation of our members to individuals of the boards; or, as has been suggested, by having the constitution so amended that they may become associate members. The subject is one worthy of consideration, and when we come together next year, if we decide to amend the Constitution so as to admit associate members, perhaps some provision can be made to carry out this suggestion.

COMMITTEE ON MEMORIALS.

A matter recurs to me which was overlooked yesterday. It is the appointment of a committee to prepare a memorial in regard to the deaths of two of our members—Mr. W. C. Taber, of New Bedford, Mass., and Dr. Estes Howe, of Cambridge, Mass.—who departed this life during the past year. It is proper that that should be done; and, with the permission of the Association, I will appoint as such committee Messrs. Stiness, Cabot and Allyn, and request them to send suitable minutes promptly to the JOURNAL, so that they may be published as a part of the proceedings of this meeting. Unless some objection is made that will be the order; and the gentlemen named will kindly accept the duty and give it their usual prompt attention. The committee appointed to prepare a minute on the death of Mr. Wm. J. Miller, of Bristol, R. I., will also send their report in the same way, and kindly attend to it at once. [For report, see page 179.]

THE QUESTION-BOX.

We have now completed our regular programme, at least so far as the reading of papers is concerned, and unless some member has other business to bring forward we will open the Question-Box and determine what it contains for our information.

The first query is—

“What is the best way to prevent a gas main laid across a stone culvert from being stopped up in the winter?”

Some of the members who have laid mains over or through bridges or culverts will kindly give us the benefit of their experience, and suggest a remedy to our friend who asks this question.

Mr. Cabot—Many years ago I had occasion to lay a main over a culvert, which subsequently gave us trouble, and I finally took it up in order to overcome the difficulty. I placed a larger pipe around the main, which permitted a circulation of air between the outer pipe and the main; and that seemed to overcome the annoyance, for I never heard of any trouble there since.

The President—Will Mr. Cabot state the depth of soil covering on the pipe, and what on the top of the culvert?

Mr. Cabot—Between 3 and 4 feet. The top of the sewer was about 4½ feet below the surface, and the pipe rested on the sewer.

Mr. Leach—I have done the same thing in open culverts, and have never had any trouble at all. I have also used the same means on my lamp posts—using a larger sized pipe for a frost-jacket. I now have no trouble from frozen lamp posts.

Mr. Coffin—We had an experience very similar to that of Mr. Cabot, but we boxed the pipe and packed it in with tan. We have not been bothered with it since.

Mr. Jones—Some time ago a friend of mine called my attention to lamp-black as a non-conductor. He told me he had laid pipes in boxes and then packed lampblack around the pipe. The system hindered the formation of deposits and prevented the freezing of water in the pipes. He said that steam pipes so packed would not melt snow on the top of the ground; in fact, that they did not even thaw the ground about the box appreciably. He thought it was one of the best non-conductors he had ever seen, and not very expensive.

Mr. Moore—We were obliged to carry a pipe (we passed it through a larger pipe) over a culvert, but a short time ago the gas stopped, and on tapping it we found it was frozen solid. In consequence the explanation so far given does not help us any. The jacketing plan was of no use in the case of a pipe 18 inches below the surface in a place where the earth was frozen to a depth of 4 feet.

The President—How does Mr. Moore think the solid ice came there?

Mr. Moore—By condensation; and in no other way.

Mr. Humphreys—I have covered several pipes so situated with regular steam pipe covering—that is, with a layer of asbestos paper, hair felting next, and then asbestos paper again, and canvass over all, finished with a thorough coat of paint. We have, within the past two years, covered six or seven such pipes in that way, and have had no trouble with them since. Where elbows are met we use, if we can, an outside elbow two or three sizes larger, and run the gas through that. We have found it a great benefit. It gives the gas a chance to expand. The gas passing into the larger elbow does not seem to have the tendency to freeze that it has with the regular size of elbow.

Mr. Prichard—From some of my past experience I think the best remedy is to enlarge the pipe. The main point to be observed is to pack at the point of contact with the frozen ground, or in the wall. The point where the pipe touches the wall seems to be so intensely cold that everything catches in it at that point; and if the pipe can be packed along for four or five feet it does not seem to fill up. I once had that experience in the West with a pipe that crossed a bridge. The pipe froze as it came through the wall; but by covering it with a box at a point two feet from the wall, and into the wall for two feet, the trouble was remedied.

The President—I trust, from the suggestions made, Mr. Moore will see some point that will enable him to overcome his difficulty. The next question is—

“How many cubic feet of gas is represented by one cubic foot of retort carbon?”

Mr. Stedman—The question is not quite clear, to my mind. Does it mean to convey the idea that the gas is diminished in volume by the deposit of carbon on the retort? I would take the ground that it would very probably increase the volume. It is quite possible to split up some molecules of gas that are very rich in hydrocarbons and, by doing so, double their bulk. Some of the gentlemen who visited Pittsburgh after the Philadelphia session of the American Association saw a process of decomposing the natural gas in the presence of incandescent coal, thereafter enriching the products of the decomposition with naphtha and crude oil, or with any rich kind of carbon or oil, which greatly increased the bulk, not only of the gas after it had been enriched, but before it had reached the enriching stage at all. In fact, by passing it through a meter it was found that it had nearly doubled over the bulk of the quantity of natural gas first worked on. A very large proportion of the natural gas consisted of marsh gas; and the supposition was that in

presence of the coal it was decomposed and split up—one volume of marsh gas being split into two volumes. If that was true in that case, it might be true with any gas rich in hydrocarbons, coming in contact with the hot surface of the retort, that a portion of the carbons may be extracted, allowing the molecules to be split up, or making two volumes out of one, thus doubling the bulk.

Mr. Taber—I hope no member will go home and try the manufacture of gas carbon, because, even if we are going to double the volume of gas, it seems to me that by breaking up the particles of marsh gas and leaving the carbon on the wall of your retort you may get some hydrogen into your gas, but you will not get any light from it.

Mr. Neal—I find it quite profitable to manufacture retort carbon, because, having removed it by using coarse salt for several hours, if it is then put into the generator it yields about 45,000 feet of water gas per ton, which, when enriched with naphtha, goes out and is utilized as illuminating gas. I use all the retort carbon made by us at Charlestown in that way—in the regenerators of my water gas plant; and when I have no retort carbon to use I use coke. We put the coal into the retorts, get all the gas out of it that we can, and then put the residuals into the generator and get 45,000 or 50,000 feet more.

The President—What does Mr. Neal think would be the value per ton of retort carbon as compared with coke?

Mr. Neal—About the same, with coke at \$3 per ton in the yard.

Mr. Allyn—When you speak of 45,000 feet, you mean to the ton of carbon?

Mr. Neal—Yes, sir.

The President—The next question is—

“How much coke is used, by measure, to carbonize 2,240 pounds of coal, with yield per pound?”

I think that, perhaps of all the members of the Association, the best able to answer this question is Mr. Stiness, of Pawtucket R. I.

Mr. Stiness—I feel that that is an important question, but am a little sorry the coke question has been sprung upon the Association at this hour. I read in a Boston paper that a professor of Harvard University, under the dome of the State House of the good old Commonwealth of Massachusetts, stated that coke would not heat water and produce steam which would drive a dynamo, to produce the electric light; and I thereupon said to myself, “If it won't make steam, what is coke good for?” I think Colonel Stedman spoke my sentiments last night when he said, after reading that remark, that he was thankful this matter was going to come into the hands of practical men. As to the question, some time before this meeting my attention was called to the results—which, to me, were remarkable—obtained at the Pawtucket works, as compared with those of former years. These were obtained by the introduction of a regenerative furnace, (not a recuperative one, but a small regenerative furnace of the Dieterich pattern), and desiring to know whether I was securing results that were marked in their character, I sent out some questions and statements. I instantly ran upon a snag in the coke question. I took, as an arbitrary basis of figuring, 36 bushels of coke as being the product of 2,240 pounds of coal. I was immediately met by a response from one of my good friends that I must take 42 bushels as my standard. Then, again, friend Greenough said the standard was 42 bushels, of 45 pounds weight to the bushel. So I said, 42 bushels of coke at 45 pounds to the bushel, 12,500 cubic feet of gas, from 10 to 15 gallons of tar, with a certain quantity of ammonia, and I was in the predicament of the Indian who was allowed to have three wishes. His first wish was for rum; his second was for tobacco; but when he came to the third wish he did not know exactly what to wish for, and so he concluded that he would have a little more rum. So, in my case, with the 42 bushels of coke, 45 pounds to the bushel, the 12,500 cubic feet of gas, with the ammonia, and other incidentals—and they all weigh something—I thought I ought to have a little more coal. To determine the matter, I carefully weighed 990 pounds of coal into three retorts. The coal, after remaining four hours in the retorts, was drawn, hauled and deposited in a place in the yard that was paved with a concrete floor, and measured—and it was measured carefully. The product was 18 bushels of coke, which equals 40.73 bushels to 2,240 pounds of coal. In some other experiments I found that the carbonization of 30,475 pounds of coal left for sale 375 bushels of coke. The 30,475 pounds equals 13½ tons of coal in round figures, which makes 540 bushels. The 375 bushels of merchantable coke (without any fine coke or dust measured at all) gave 165 bushels of coke as the amount consumed in the furnace, and the gas product equalled 167,000 cubic feet. This gives 12½ bushels of coke to carbonize 2,240 pounds of coal. I then took another bench with a good furnace, and in this connection let me say, that I selected an ordinary working day, with its missed charges, and when the furnace was not worked to its full capacity, for I considered that such a day would give perhaps a more exact statement of the average working, and charged it with 5,966 pounds of coal, which produced 106 bushels of coke. There were 74 bushels of coke left for sale, which, reduced to bushels of coke per ton of coal carbonized, was 12. Then I made another experiment with the same six benches, with 35 retorts, and found that I used 31,544 pounds of coal, and produced (at

the 40 bushels to the ton ratio, which I accepted for the time as a standard, but which I do not adopt in my own works), 564 bushels of coke. There was left for sale 372 bushels, so that 192 bushels of coke was used to produce 174,000 cubic feet of gas; which would equal, I think, $13\frac{1}{2}$ bushels to the ton of coal carbonized. That was done in what is termed the Dieterich furnace. My only reason for making those experiments was—as there are to-day other furnaces presented for our consideration, and as I feel that by the use of the Dieterich furnace I can, from what knowledge I possess, produce as much gas per mouth-piece, and as much gas per pound of coal, as I could with any other furnace—to discover whether I was working as economically as I ought, in the amount of coke consumed. I have taken here, as you gentlemen to whom I have given the figures remember, the arbitrary standard of 40 bushels of coke to the ton of coal. If these figures be increased to 42 bushels, the quantity of coke consumed will be increased. If one figure, as an article of merchantable coke for sale, on 36 bushels, of course my results are very much better still. I give you these figures as the practical, every day workings of a retort house. Some of the retorts that I am now using have been constantly employed for more than 20 months, and they are good to-day for 10,000 feet each 24 hours. I think, as I said before, if coke is so perfectly worthless that it cannot heat water and make steam, then perhaps we had better let this question go, and find some other more profitable item; but during the past few months, when every gas company has been put to its wits end to furnish its customers with the amount of coke they wanted, it seems to me a very important matter. If there is any furnace to-day which will carbonize 2,240 pounds of coal with any less coke than that used by the Dieterich furnace, I would be very much pleased to be told of it.

The President—We have had a very interesting statement from Mr. Stiness. Mr. Nettleton has been at work on this matter for some time, and we would like to hear what he has to say in answer to this question.

Mr. Nettleton—As I was one of those who received a letter from Mr. Stiness, perhaps it is fair that I should speak immediately after him. When he kindly sent me the figures that he did I was struck with the marvellous success he had met with. That was apparent on the face of it. I then set to work figuring the matter out, and I came to the conclusion (and I think all of you will join me in it if you will take the trouble to figure out the result) that those figures are not equalled to-day anywhere in this country, and that we have never yet had reports from any gas works in Europe of their being equalled, with a simple regenerative furnace. Mr. Stiness has stated it perhaps more modestly than he ought. On the basis of his statement he sells 27.7 bushels of coke to the ton. After allowing 70 feet of gas per gallon of oil used, he makes a yield of 5.40 feet per pound of coal. For a simple regenerative furnace I do not think that work has been equalled. I take a great deal of interest in this subject. I am one of those who are trying to solve the dollar problem, and hope to live long enough to accomplish it. I do not believe it can be done except by saving the largest possible quantity of our residuals, and selling them for the very highest price. In that connection I desire to say that I know of one gas works where they sell—absolutely sell—34 bushels, of 2747 cu. in. each, of coke to the ton of 2,240 pounds. Of course, this is not done with a simple regenerative furnace; it is one of the elaborate recuperative ones. I think it is possible for most of us to sell 30 bushels of coke to the ton. I know of works on the seaboard, and competing with cheap coal, where nine cents per bushel of coke is received in the yard; that, for 30 bushels, would be \$2.70. I know of other works where they get 70 cents per ton for tar; I know of other works where they get 25 cents for ammonia. Together these amount to \$3.65. If coal costs \$4, the difference is 35 cents, or $3\frac{1}{2}$ cents per thousand feet. In addition to this economy the introduction of these furnaces has greatly cheapened the cost of labor. In my own works I have for a month past made nearly 27,000 feet per man; and these men have brought in the coal, charged the retorts, taken care of the furnaces, taken the coke into the yard and piled it, and run the boiler; and one of them very willingly said he thought it would be about as easy for him to put 2,000 pounds into the six retorts as to put 1,800 pounds. I believe it is only in following this furnace question, with all it involves, out to its utmost limit we can ever hope to solve the dollar problem.

The President—Col. Stedman has had large experience in this direction, and we would like to hear from him.

Mr. Stedman—I do not know that I have anything new to offer, in addition to what I have said hitherto. I have not made any careful experiments with regard to the amount of coke used during the last year at all; and I do not know that I can impart any information about it. It seems to me very plain, however, that the regenerative furnace is generally accepted as being exceedingly economical with fuel as compared with the old fashioned furnaces, and, consequently, I suppose that they will be very generally introduced sooner or later. The other obvious advantage of the regenerative furnace is the ease of management, and the steadiness of heat maintained. The question of coke is one that has to be solved by nearly every person, under his own

peculiar conditions of production and sale. While we may bring 42 bushels of coke into the yard from a ton of coal, and, by carefully measuring it up into standard bushels, ascertain exactly its bulk according to the government standard, yet, in my experience, there is always a considerable diminution of bulk whenever the coke is handled. Generally your workmen are inclined to the charitable side of the question when they measure a bushel for a customer who comes into the yard with his wheelbarrow after it, and it is pretty difficult to determine, unless the coke is binned every day with the determination that so many bushels shall come out of that bin, to be able to sell as many bushels to the ton as you know you ought to sell, and as you know that you are producing for sale. Before this year we have always piled up the coke in the yard during the months of August, September, and October, when our greatest consumption occurred, and the lowest sale of coke was also incident to the same period, consequently we found, upon the commencement of cold weather, that we would have from 10,000 to 15,000 bushels of coke in stack to freeze and thaw, and consequently disintegrate, and leave us with an enormous pile of breeze when we came to clean it up in the spring. To obviate that difficulty, when we moved to the new works, we had left upon the old place quite a large coal shed, which we took down and carried to the new location, and put up there a coke shed capable of holding about 40,000 bushels under cover. The intention is to take the coke during the times of greatest production, pass it through the breaker, and store it in the different bins intended to contain the different sizes, so as to have it ready for sale, when the larger demand for coke comes in the spring, at a period of the year when our production of coke is smallest. I think by this means the amount of coke that we will sell will be greatly increased. We have located the crusher about thirty feet high from the ground, and connected with the crusher is the ordinary revolving screen—the different sizes of the screen being located over different bins—so that as the coke is lifted to the crusher and comes into the screen it first passes into a screen with a quarter-inch mesh, which takes out the breeze; the next screen has a three-quarter-inch mesh, which deposits in its bin what we call the pea coke, generally sold for one cent less than common coke. The next bin is our prepared or stove size, which is passed through a two-inch mesh. The next bin contains the coke that is rejected from all the screens and has not been sufficiently broken to pass through any. We sell that as common coke. The prepared coke sells for two cents per bushel more than the common coke, and the pea coke for one cent per bushel less than the common coke. Our prices are ten, eight, and seven cents. I hope to greatly increase the book account of the amount of coke sold at the end of the year by reason of the saving which I think we will effect in keeping our coke stored during the inclement weather from the action of the frost, snow and ice. I question whether it would not be good policy for those situated as we were—liable to have a large amount of coke to store during the severe weather—to have some kind of shelter to protect the coke from the action of snow, frost and rain. I know that has been a serious loss for us year after year. The regenerative furnace claims to yield (in some cases) as high as 33 bushels of coke per ton for sale. I believe there is one instance on record in this country where, after a careful account for a month, that has been determined to have been the exact amount—or rather between 33 and 34 bushels had been sold from a ton of coal daily. In this case the sale was quick, and there was no remeasuring; the coke was drawn from the retort into carts and taken away immediately. That represents a low consumption of coke, and is a pretty large sale. If we could average ten cents per bushel for the coke, 70 cents for the tar, and 50 cents for the ammonia, and our coal cost us only \$3.50, we would then begin to solve the dollar problem.

The President—It is quite encouraging to know that the dollar rate is near at hand. It must be very encouraging not only for gas companies, but for consumers as well. I think that Mr. Lamson can give us some valuable information on that point.

Mr. Lamson—I have no figures of the kind. In the furnace which has the most interest for me at the present time we are using from 60 to 70 bushels of coke every 24 hours, and are carbonizing in the six retorts heated by that furnace 2,000 pounds of coal every four hours—the make of gas (using naphtha, but not counting it in) is about 5.15 to the pound—which is in the vicinity of 12 bushels to carbonize each ton of 2,240 pounds. We count 42 bushels of coke to the ton of coal, and 45 pounds to the bushel. That standard is the result of a great number of experiments made during many years, and carried out in very similar manner to that described by Mr. Stiness.

The President—The experiments were made on Westmoreland coal?

Mr. Lamson—Yes.

Mr. Stiness—What furnace do you speak of?

Mr. Lamson—One that we got up ourselves, and have used for a good many years. At the Commercial Point station we are using some furnaces of another sort. We originally heated seven retorts, but we now heat six large retorts. These furnaces would very easily carbonize over 2,000 pounds of coal in four hours, but we have not as yet been able to satisfy ourselves that the retorts would stand the heat sufficiently to carbonize the larger

charges. We charge 333 pounds to a retort, and have experimented with 350 pounds. The furnaces worked the gas off from that quantity pretty well, but the practice showed an injury to the retort settings.

The President—Probably Captain White has had as much experience in this line as any of us, and we would like to hear the result of his experiments.

Mr. White—I do not believe that the gentlemen would care to hear anything from me upon that subject, because I am not running gas works possessed of any modern furnaces. The information I have is simply that gathered in visiting various works, therefore I can relate nothing from my own personal experience. I have listened to the gentlemen who were speaking, and believe it is a fair thing to say that anywhere from 15 to 16 bushels of coke per ton of coal carbonized would be a fair average. Some engineers say they can get along with 12 bushels; but those are very few in number. In fact it is likely the greater portion of the fraternity does not manage to come anywhere near to the 15 bushel figure even. I have great diffidence in offering any opinion on the subject from the fact that I am not operating a gas works equipped with modern furnaces.

Mr. Jones—Did I understand Mr. Lamson to say that he got a yield of 42 bushels of coke, of 45 pounds per bushel, from a ton of 2,240 pounds of coal?

Mr. Lamson—Yes.

Mr. Jones—That would be 1,890 pounds of coke. Mr. Lamson says he gets 5.15 cubic feet to the pound of coal; but suppose we figure on a yield of 5 feet; that would equal 11,200 cubic feet to the ton of coal. Now, his gas would probably weigh 40 pounds to the thousand—an 18 or 19-candle gas ought to weigh a little more than that—or a total weight of 448 pounds of gas. Adding the 448 pounds of gas to the 1,890 pounds of coke, and we have 2,338 pounds of gas and coke from the distillation of 2,240 pounds of coal. Let us suppose the gentleman also gets 10 gallons of tar—which would weigh something; and there must probably be two or three pounds of ammonia in the liquor flowing from the hydraulic main; the sulphur ought also to contribute a trifle in the matter of weight. In view of these figures I am inclined to say with Brother Stiness that we ought to have a little more coal.

Mr. Lamson—That may be all very well; but when you take a statement you ought to take it as a whole. When I told you that I made 5.15 to the pound of coal, I took pains to add that we put in a little naphtha, and did not take any account of it. You must not draw conclusions from my figures unless you take the whole of them.

Mr. Jones—I figured at 5 feet to the pound, and the coke and gas alone would amount to more than 2,240 pounds.

Mr. Lamson—Then you figured wrongly. I can show you experiment after experiment, made with the greatest care, which gave us 42 bushels to the ton, of 45 pounds to the bushel. In order to verify the results, those experiments have gone into the hands of as many as four different men—each acting entirely independent of the others—and, at times, carried on by two different men at the one period, but at different stations of our company, in order to satisfy ourselves that no errors were made; the books of our company are carried out on those figures.

Mr. Prichard—I suppose there must be a waste in quenching coke which would tend to make a discrepancy.

Mr. Lamson—The question of water is, of course, a very material one, but in our Boston experiments, likewise in experiments of this kind made by others, the experimenter takes all such things into consideration. In our case, a certain length of time, a definite fixed period, has been allowed for this water to settle away from the coke. I think that in most of the experiments 24 hours have been allowed for that settling. In fact, the experiments have been carried much farther than that, for we have taken coke which had been standing for from 24 hours to 6 weeks.

Mr. Stiness—I understood from Mr. Lamson's statement that he estimated on dry coke. In making my figures, I calculated them on dry coke. If he figures upon wet coke, of course I can understand where a discrepancy might come in; still, it seems to me that in twenty-four hours the coke would evaporate a good deal of water.

Mr. Lamson—What is dry coke? You would not take coke which was drawn out to-day and never quenched?

Mr. Stiness—The experiments made by the Guild of Gas Managers were with hot coke; and, as already said, my information came from dry coke. As intimated before, I did not question the quantity (42 bushels) of coke so much as I did the weight.

Mr. Allyn—You may remember, Mr. President, that some two or three years ago I read a paper before the Association on this very subject—the yield of coke per ton of coal—and in it I gave a number of illustrations to cover the point now being discussed, that it was absolutely impossible to make an accurate test if any water had been thrown upon the coke after it came from the retorts, and before the weighing was done. I claimed that the only absolute method was to weigh the coke as quickly as possible after it came from the retorts. In our experiments we ran the coke right on to a

scale as soon as it was drawn from the retort, and weighed it there. I found that, using the smallest quantity of water we could to quench the coke, and allowing it to lay for days in the warmest season of the year, it would retain a large quantity of water. I determined this by making a small, but very careful experiment. I took a piece of coke, laid it on a steam radiator, left it there for 24 hours, and then reduced it until it weighed, on a post office scale or balance, exactly one pound. I then put it into a basin of water, allowed it to remain immersed for 15 minutes; when I re-weighed it, I found that it weighed exactly $1\frac{1}{4}$ pounds, which showed that it had absorbed 75 per cent. of its own weight of water.

Mr. Nettleton—Some years ago, in making some experiments as to the quantity of water that could be evaporated in a boiler by different fuels, I went into the matter of evaporation by coke quite carefully. The coke was taken from a pile which was exposed, or which had not been covered by a shed. That coke, running through 72 hours, averaged 38.8 pounds to the bushel. It is but fair to add that it was in the summer time, and there had been no rain for weeks.

The President—I think we have pretty thoroughly covered the question, and I trust that the gentleman who asked it feels pretty well satisfied with the answers. We have one other question remaining. It is:—

“Can a gas company afford to devote its attention to electric lighting?”

That matter has been alluded to several times during our discussions, and if we are to get any further light upon the subject, now is the time.

Mr. Neal—Certainly; as the manager of a company which is lighting by electricity as well as gas, I answer that it can. Especially so if its charter is so framed that it can combine both kinds of business in one management, and so not be obliged to organize outside, as many companies have had to do. To remedy that difficulty, many of the gas companies are now before the legislature asking for a change in the law which shall authorize them to carry on the supply of electric light in connection with the gas business. The company of which I am the manager has been in the business just five months; and, as I tell those who ask me about it, I have no larger salary than I had before; I did not have to put any more furniture into my office; I have no more bookkeepers, no more collectors, no more men at the boilers—in fact, I have had to employ only four or five persons in addition to those who were originally employed in the gas works. The added helpers are a trimmer, engineer, linemen and patrol men. I suppose you all know that at Charlestown we bought the line and structures of the Weston Company. They offered to sell almost before we approached them on the subject, so that everything was perfectly harmonious. We did not attempt to raid upon them at all. We at once assumed the electric lighting, and instead of endeavoring to stand in the way of furnishing electric light, or to induce all our customers to burn gas solely, we attempted to enlarge our business by electric lighting, and have more than doubled the number of lamps that were then in use. We have a three-year contract with the city to furnish electric lights for lighting the streets. I answer that question most positively by saying that a gas company can afford to give its attention to electric lighting, in connection with its gas business, provided the field is clear. I cannot say what it might be if competition existed, in the shape of a local electric company, because then the rates might be so reduced that it would not be a paying business; but where one holds the field, as we do, the business can be done to very great advantage.

The President—Can it be done with profit to the stockholders of the Company?

Mr. Neal—It is done with profit to the stockholders of the Charlestown Gas Company.

Mr. Prichard—What prices do you get?

Mr. Neal—We get 65 cents per night, for every night in the year, by our street contract. For the commercial lights, which burn until about ten or twelve o'clock, we get 50 cents. For some private lights that burn all night we get 75 cents a night. Some of the railroad companies are paying that. For two lights we get 70 cents; for three, 65 cents; for four 60 cents; and for quite a number the rate would be 50 cents. We conform to the Boston rate as nearly as possible.

The President—Are there any Lungren lamps in use in Charlestown? Has the Company given them any attention?

Mr. Neal—Not at all. We should do so most certainly were we not in the electric light business.

The President—I want to ask Mr. Neal a practical question as to that very point. It is this: Whether if the manager of the Charlestown Gas Company had given the same energy and attention to the subject of introducing and using the Lungren lamp which he has given to introducing electric light, the results would not have been quite as good to his stockholders, and quite as satisfactory to the people?

Mr. Neal—By no means, because I do not think it would be possible to introduce the Lungren lamp for street lighting.

The President—But aside from street lighting—for general use among your consumers, leaving the matter of street lighting out of consideration?

Mr. Neal—I do not. It is true we have to furnish our plants in stores, to provide for the running of wires, and also to furnish a cut-off box on the outside of the building, or in some convenient place; but if we were furnishing the Lungren lamps, very likely we should do the same thing at less expense. Some of the lamps which we put in stores cost \$65 each.

Mr. Prichard—How many commercial lamps have you?

Mr. Neal—We have 39 city lamps now, and in all we have fifty. The only reason why we do not put in more is because our plant is not sufficient. We are now arranging to enlarge the plant, and to move our dynamo and engine from the condenser room (where they were placed first, as an experiment) into a separate building.

Mr. Greenough—Does Mr. Neal propose to develop his electric lighting business at the expense of his gas plant, because he thinks there is more money in it?

Mr. Neal—In some cases there is more money—that is, where people will have the electric light. If we did not give people the light when they desire it, it is very likely that another company would come in and take that business from us. I think there is a very handsome profit in electric lighting when carried on by gas companies; and I am surprised to learn what was said at the State House the other day in relation to coke. I am surprised that a Harvard professor should make such a statement as the one reported—that you cannot generate steam to advantage for electric light purposes with coke. We have done that very thing for five months, and to very good advantage. I also heard it was given in testimony at the hearing at the State House that it was impossible to generate steam for ordinary purposes with coke. All the gas companies in the land have done so for years; in fact, they have done so ever since the introduction of gas as an illuminant.

The President—Can any other gentleman express an opinion upon this subject founded on his experience? We have had lots of theory.

Mr. Stiness—Whether Mr. Neal is correct or not in his theory, I believe he is absolutely correct in his facts. I heartily agree with everything that he has said. The question asked is a practical one, and he answers it by saying that he does not extend his electric light at the expense of the gas company, but that he controls the consumption of both, which, in my opinion, is a very important point.

Mr. Neal—Let me say this in addition. Most of our electric light business is new business for the gas company. The arcs on the streets did not displace any gas lamps; they were in the nature of additional lights. We have a good deal of business in the way of electrical lighting in places where gas could not be used—for instance, on the railroads. The Fitchburg railroad people are talking of putting in a quite a number of arc lights over their tracks and in their yard—where we could not have put in our gas lights; the latter would not have been serviceable. When we bought the local electric light company, we also bought out their structures and wires; and we, therefore, have the entire business in our control. If we had not done so, they would possibly have by this taken many of our consumers away from us.

The President—Before this discussion is closed I desire to say a few words in connection with the subject. I trust the members of the gas fraternity will not forget the object they had in view when they entered the business of making and selling illuminating gas, at least not until they have carried the business to that state of perfection where there is nothing more to be learned with respect to either manufacturing or distribution. I have not yet made up my mind to go into the electric light business, because, in the first place, I have very little time to devote to it; and, in the second place, I know very little as yet about the business in which I have spent so many years. I find, year by year, that I have still a great deal to learn; and I would like to attain very much nearer perfection in the business of making and selling gas than I have yet attained before I branch out into anything new. There may be gentlemen who have plenty of leisure, who can prudently go into the electric lighting business. I have no objection to their doing so; but I apprehend that, as an Association, we had better not let ourselves be carried away absolutely and overshadowed by the shadows that are thrown by the electric light. I think we can bring gas to such a state of perfection that it will make the shadow go in the opposite direction—in comparison. I do not agree with my friend Neal that it is necessary to have the electric light for street lighting. I know there is quite a hue and cry for it around the country, and that it has been largely introduced; and he further suggests, with regard to certain places where gas could not be introduced that, therefore, the electric must be. I think perhaps he is in error on that point. Gentlemen who have visited the city of Philadelphia know that large places there are, by the use of the Siemens burner, lighted by gas, that were formerly lighted by the arc electric light; that within a year the change has been made in various squares in Philadelphia, greatly to the satisfaction of the people who have passed by, to the satisfaction of those living in the neighborhood, and to the public generally. I have carefully inquired as to the feeling of the people of Philadelphia about the subject since the meeting of October, in Philadelphia, where our attention was called to it; and I am satisfied, by the use of proper burners, the result desired can be attained, and perhaps at a lessened cost than by the use of the electric light. It has been claimed, and still is claimed, that the electric light is essential in some kinds of business—as for the purpose of bringing out shades and colors; but it has been clearly and well stated by Mr. Prichard that the gas light furnished by the Lungren lamp accomplished that object in a marked degree, and in many cases even better than by the electric light. It

appears to me that an argument in favor of the electric light based upon this claim can be done away with almost entirely by the use of such burners as the Lungren lamp; and thus we may be able to retain our business instead of allowing it to be taken from us by the introduction of the electric light. I think the question of comparative cost will largely enter into the continued use of either means of artificial lighting. I believe if the gas men who are engaged in the gas business will devote as much of their energy in the next five years as they have in the past five years to the question of the proper manufacture and consumption of gas, they will find their business not running down at all, but continuing to increase—the general report is that it is increasing throughout the country—and that they will not find any very serious competition from the electric light. I grant there are conditions and places under which and where it may still be called for, and will be called for; but that the electric light business is going to be the bear to eat up the gas companies I do not believe; and if it does, it will be our own fault. I do not wish to be understood as opposing the introduction of electric light by a gas company, if an individual gas company thinks it best to unite that business with that of supplying gas; but what I want to impress on the members is the idea that we must not lose sight of the gas business, and what can be accomplished in furnishing gas for illumination, and devote our attention to the introduction of the electric light. We can much better afford to put a small investment, as was suggested by Mr. Richardson, into the purchase of the Lungren lamp, or something that may surpass it, than to put fifteen or twenty times as much money into an electric light plant, which will tend largely to cut down our gas business through our own failure or neglect to push the gas business as it should be pushed. (Applause.)

Mr. Neal—I hope the Association will pardon me for speaking again; but I have been asked if our business has increased. I answer that it has increased very much during the last year—at least ten per cent. The President says that the electric light is not necessary. Well, it may not be necessary; but the practical question for us to consider is, does the public demand it? If it does, it must have it. I want to thank the President for the good advice he has given me, not to neglect the gas business. I am not doing that. I am giving my attention to it, and I hope in time to have regenerative furnaces, and to increase the capacity of my benches. To show that I am very progressive I may state, which perhaps some of you already know, that I have a very pretty auxiliary water-gas plant; that it is doing very well; and that I am not sorry I put it in, although the price of naphtha seems to be rising steadily to six cents per gallon. The business of gas lighting in Charlestown seems to be increasing very rapidly, and I am devoting my energies to the improvement of all the machinery for the purpose of meeting that increase. I want to say that during this discussion, while listening to the remarks of my brother from North Adams with regard to the Lungren lamp, I have been thinking where I could put those lamps to the best advantage; and I propose to place them just the same as I would do if I had had nothing to do with the electric light.

The President—Is there anything further to be said on this question. If not, we will consider that the question has been fully answered.

Mr. Stiness—I do not want to be misunderstood with regard to my statement about being taken in by the bears. My statement is that unless the gas companies advance, by entirely abandoning the policy of "We get along well enough now" (those days have passed), and take up this question of improved burners, and press it upon the community in the same manner and with the same force that the electric light companies press their business, the gas companies will get inside the bear.

The President—I wish to emphasize Mr. Stiness' suggestion; and I am very glad that he made it. I think if the gas managers devote as much energy to the introduction of improved burners, and improved furnaces, and to the pushing of their business generally on business principles, as the electric light companies have been and are doing, that the success of gas companies has hardly commenced. Just look at what has been done in the last five years. Now, if you will go on in the next five years and surpass what has been done in the past, the result will astonish every man here. There is no question about it.

Before a motion to adjourn (the regular business of the meeting having terminated) is offered I desire to present further proof of what has been said with regard to the probability of our continuing in the business of making and selling gas, with the object of furnishing it as a means of illumination and of use for domestic purposes. If we need any encouragement in the hope that we are not to be turned out of doors, a gentleman is present with us who can give us words of encouragement. I know that our members are always delighted to hear him, for they always receive some valuable suggestions from his counselling. His words of encouragement will send us on our way, until we have the pleasure of meeting again, with feelings of rejoicing. I refer to our esteemed friend, Mr. G. Shepard Page, of New York, and ask him to say a few words. [In response to the invitation, Mr. Page made the following remarks:]

REMARKS OF MR. PAGE.

Mr. Page—It certainly is needless for me to say that it is a pleasure to meet with you, for an invitation to attend your gatherings is always one of the pleasantest experiences of my business life. Although not privileged to have been with you yesterday, but be-

believing that the interesting proceedings of to-day are a duplication of yesterday's, I am sure that the anticipations of good results that are to come from this meeting will be realized.

I do not think that the gas industry is in its declining years. An industry that has gloriously survived so many fierce attacks that emanated from so many quarters; an industry that has had its life extinguished, and been reported buried (by its enemies and the press) so many times, but which to-day is sending out more light throughout the world than any other agency, and that light increasing at the rate of 15 or 20 per cent. per annum, thus doubling in every five years, with its cost becoming less and less every year, I submit there can be nothing to fear with regard to its permanence.

While it is a moot question, and one worthy of discussion, as to what additional agencies or helps shall be drawn to the industry from other sources of lighting, yet certainly nothing can be added to it that will be cheaper; and only the special features—the special advantages of any locality—would cause a gas manager to say "yes" or "no" to propositions for enlarging his mode of lighting.

Perhaps you will permit me, and possibly expect me, to add a word or two with regard to that of which I know more than of any other subject, and that is the outlook for the residuals of gas making. The depression still continues. The prices of coal-tar products did not advance 1 per cent. in Europe during the past year; and they were only advanced in this country by the combination among the tar distillers. I have been very glad to notice that in some sections, and with some companies, the price paid for coal tar has been satisfactory. With the old contracts running at the low prices, it could hardly be expected that the contractors would come forward and offer an advance before such contracts expired. The outlook in the United States is now quite encouraging. I believe that the time is near at hand when every paving stone used in our cities will be laid with a foundation of coal tar and asphalt, and the spaces between filled in with coal tar pitch. That demand alone will cause the price of coal tar pitch to advance materially. In that event it will require a large percentage of the production of the country for this use alone. It is the best pavement for cities that can possibly be constructed. One of the most striking things that I saw in visiting the old country, in 1870, was the way in which the street pavements of the city of Manchester were being made. For some four or five years the authorities had been taking up the old pavements and relaying them in that way. It was the best paved city that I visited between Queenstown, in Ireland, and St. Petersburg, in Russia. The use of it on the other side has steadily grown; but, singularly enough, its use here is growing more rapidly than in Europe. In Boston it has been used to some extent; but in the cities of the Middle and Western States this system is being widely adopted. The new granite pavement on Fifth Avenue, New York, is being laid with the use of pitch.

It has been found, after the most careful experiments by engineers in New York, who have had in hand the mode in which wires shall be laid under ground, that the concrete pipe made by the use of coal tar pitch, instead of natural asphalt, is one of the best protections that can be employed.

As you know, the Legislature has required all wires in New York City to be placed under ground; and that must soon be done in all our cities, for it is found to be a cheaper and better way than the present mode of stringing wires. I am sure that the substance principally required for that purpose will be coal tar pitch, which forms 75 per cent. of the bulk of the tar. This increasing use will certainly raise its value, and its enhanced value will naturally cause a better price to be paid for the tar.

During the past year, for the first time in the history of coal tar distilling, a very large percentage of the creosote oil was used for wood preservation. Creosoting works have been built in several new sections by railroad companies and by private parties. This will give a greater value to the creosote oil than has been realized for several years.

Benzole is still at the low ebb at which it has been for two or three years, caused by the enormous production all over the world competing for the demand for color making, and the failure of the manufacture and demand in color making and color using to keep pace with the increase in the production of benzole. Therefore, instead of selling at seven shillings per gallon (the first time I made a gallon of refined benzole, in Chelsea, in 1860, it sold at ten shillings or \$2.50 per gallon), it is now selling at 37 1-2 cents per gallon. The naphthas are being used to a greater extent; but the value has not

yet much advanced. Anthracine has fallen to so low a figure (twenty cents per unit per hundred weight) that it does not pay the American tar distiller to make it. I have sold many thousand pounds at \$1.50 per unit per hundred weight. Naphthaline, however, is becoming a more important product; and from that source the tar distiller will eventually derive a large income. Not only by its use in the Albo-Carbon burner, but also in the mechanic arts in various ways it is becoming an article of marked interest. Its latest use is in an explosive, and the power of the explosive is many times greater than that of nitroglycerine. It is obtained, commercially, solely from coal tar. I think it must be admitted that the outlook for coal tar is promising.

Turning now to the other residual—ammonia—I can say that the use of aqua ammonia and anhydrous ammonia, for refrigerating, is growing very rapidly. In the South alone there were erected last year not less than 60 or 70 different plants for making ice; and last year there were put into breweries, cold storage warehouses, packing houses, and hotels in the North, not less than 50 machines, rating from 5 to 100 tons of ice-making capacity per day. These machines, with hardly an exception, use ammonia as the chemical agent. The day is not far distant when in New York City every pound of ice, and all the cold that is now produced by the use of ice, will be produced artificially. The production of ice has reduced its cost even in the South to a price not exceeding \$1.25 per ton. The other uses for ammonia are increasing—particularly its use for domestic purposes. I am told that in Boston the manufacturer sends out a great tank on wheels, delivering five or ten gallons to a house, as oil is delivered. Even in Chelsea, in Charlestown and in Cambridge, the delivery is made in that way. It is being sold more largely by the druggists; but even dry goods and grocery firms are selling household ammonia put up in bottles. It is, of course, of very weak strength, of 12, 14 and 16 degrees, but of very great domestic value. In clothes washing it saves the hard labor of the washer-woman by softening the water immediately. If you use a few drops of it in the basin when washing, you feel its effects upon the skin at once. A table-spoonful in a bath tub is royal. Its tonic effect when you enter the water is very exhilarating. Anyone who has not tried it will do well to test it, and after you have once used it you will never let your ammonia bottle run dry.

Mr. Neal—Can you dispense with soap entirely?

Mr. Page—No; but ammonia saves soap. Large quantities of ammoniacal liquor are required for the aqua ammonia used for wool scouring, and in the manufacture of muriate of ammonia, nitrate of ammonia and carbonate of ammonia. In the form of nitrate of ammonia it is used quite largely in connection with nitroglycerine, as an explosive, and is found to be of great advantage. The stone is more fluely comminuted by the explosion than by nitroglycerine, and its power is greater. It is quicker, and it is also somewhat safer in transportation.

I wish I might say that the sulphur which is contained in the oxide of iron that you are throwing away now was of immediate value. Probably twenty or thirty thousand tons of brimstone are contained in the spent oxide already discarded as worthless in this country. You never throw it out until it contain 50 or 60 per cent. of identically the same sulphur that is brought from Italy. It is nearly all utilized abroad, a small price being paid for it. It is burned in peculiarly constructed furnaces, and sulphuric acid is made from it precisely as from sulphur. I think a way will be found to utilize it here.

Five years ago, accompanied by two English friends who were interested in the manufacture of sulphuric acid and sulphate of ammonia abroad, we visited and sampled three heaps in New York City, and my friends found, from an analysis of a quantity of spent oxide in those piles, that they contained from 50 to 70 per cent.—no less than 800 tons of sulphur.

I did not intend to occupy so much of your time. Indeed, I did not anticipate saying a word at this convention; but if I have added anything of interest or of value, I am doubly repaid by the compliment of your invitation and the opportunity to present these hopeful and encouraging facts.

On motion of Mr. Cabot, a vote of thanks was tendered to Mr. Page for his remarks.

VOTES OF THANKS.

Mr. Greenough—Before we adjourn I wish to call the attention of the Association to the readiness, the courtesy and the promptness with which the presiding officer has directed these meetings; and I

move that a vote of thanks be given to President Harbison for what he has done. (Seconded by Mr. Cabot.)

The motion was put by the Secretary, and unanimously adopted by a rising vote.

The President—Gentlemen of the Association: I cannot help feeling very grateful for this expression of your satisfaction at the way in which this meeting of the Association has been presided over. I certainly am sincere and honest when I say that I entered upon the performance of the duties of the office with very serious misgivings. My connection with this Association dates back to very near its organization; and I have observed and remembered the manner in which the affairs of the Association have been conducted by the gentlemen who have preceded me in the office which I now hold, commencing with Greenough, Senior, and coming down to my immediate predecessor, Greenough, Junior. The history of the Association has been marked by the very able manner in which its deliberations have been presided over; and so I say that I entered upon the performance of the duties of the position to which you so kindly called me, feeling that it would not be within my power to keep up the reputation which this Association had attained up to that time. If I have been able in any reasonable degree to meet your expectations I shall feel more than gratified. It has been exceedingly pleasing to me, during the past few hours, to hear various members of the Association speak so pleasantly in regard to what they considered the success of the meeting which is now drawing to a close. That success has been largely due to the younger members of the Association who responded so promptly to the request of the Secretary for ammunition—or papers—to be read and discussed in the Association; to the care and thoroughness with which these papers have been prepared; and largely to the members of the Association who have taken part in the discussions, and made the meeting a continued success, and of great practical value to every one of us. For the year to come I desire to ask your hearty co-operation, the active co-operation particularly of the young men, that they may, without waiting to be asked, prepare material for discussion at the next annual meeting, and for that purpose begin soon to collect data with reference to bringing it to our attention. I desire to return thanks again for your hearty vote of thanks, and to say that I fully appreciate your kindness.

Mr. Sherman—I move that the thanks of this Association be tendered to our Secretary for the very acceptable manner in which he has filled his position during the past year. It is no exaggeration to say that the success or failure of these meetings depends more upon the Secretary than upon any other officer we have; and only those who have filled the office are aware of the great amount of labor connected with the office.

The President—It gives me great pleasure to bear testimony to the faithfulness with which the Secretary has discharged his duties. I made no allusion, when I was speaking, to the duties of the Secretary, because I knew the members of the Association appreciated the labor he has performed; that before the motion to adjourn was made, a motion of thanks to him would be offered, and that then would be the time for me to say what I had to say in connection with it. It is a laborious office. It is an office that, unless well filled, the meetings would fail to be worth coming to. There is a great deal of labor connected with the proper performance of the duties of the office, and that that labor has been well done I am glad to be able to bear testimony, without any mental reservation. I feel sure that you all heartily appreciate what our worthy Secretary has done.

The motion of Mr. Sherman was unanimously adopted by a rising vote.

The Secretary—Mr. President and gentlemen: I am very grateful for this vote of thanks. I certainly have tried hard to make the meeting a success, but, as I said to you last year, without the assistance of the members that would have been impossible. To the members who have kindly prepared papers, and who have seconded my efforts, I am under very great obligations. I trust that the meetings will grow in interest year by year. I think that among our members we have many of very great ability; hence with that ability our meetings should equal in interest those of any of the Associations of this country, and with your help there is no doubt that they can be made so.

The President thereupon declared the Convention adjourned.

REPORTS OF COMMITTEE ON MEMORIALS.

The Committee appointed to prepare minutes upon the death of
MR. WILLIAM C. TABER,
of New Bedford, Mass., respectfully report:

Mr. Taber became a member of this Association in the year 1871. Those who knew him remember his genial, kindly greeting, and his fund of dry, delicious humor, which came spontaneously from the quiet unostentatiousness of the man.

Mr. Taber became the President of the New Bedford Gas Company, and undertook its management in 1854, and continued in that office until 1885, when he resigned, although retaining his position as Director until his death, in March, 1886, in the ninetieth year of his age.

During this service of thirty-one years he became acquainted with many of the gas fraternity, in New England and elsewhere, although he was seldom present at our meetings.

His patient bearing in the oft-times difficult position of a Gas Manager won for him a kind remembrance from those with whom he was brought in contact in his business.

His professional brethren need not be reminded of his readiness to be one in any combination of interests which might aid or abet the public good, either by prudent counsel or prompt action.

Although, from the infirmities of age, in the past few years he was unable to meet many of the members of the Association, yet those whom he did meet never lacked any expression of sympathy, or heartiness of reception.

Truly loved by all, he lived to see the work in his hands grow from year to year, until, at the age of ninety, he passed away.

Having been also deputed to prepare a memorial record of our deceased member,

DR. ESTES HOWE,

late Treasurer of the Cambridge (Mass.) Gas Light Company, we respectfully submit the following:

Dr. Estes Howe was born in 1815, and graduated at Harvard University in the class of 1832.

He ceased practicing in his profession in the year 1852, when he was elected Treasurer of the Cambridge Gas Light Company. In 1859 and 1871 he served in the Senate, and was, for a time, associated with the Water Board. He was also, for several years, the Treasurer of the Hoosac Tunnel and Western Railroad.

Of our friend it may truly be said that he brought to these varied trusts a high sense of honor, a spotless integrity, and a conscientious sense of the responsibilities and duties of the position confided to his care.

Respectfully submitted,

S. G. STINESS,
GEO. D. CABOT, } Committee.
H. A. ALLYN,

The Committee appointed to prepare a minute upon the death of
MR. W. J. MILLER,

of Bristol, R. I., respectfully report:

Mr. Miller became a member of this Association in the year 1871, and continued an active member until his death, although for the past few years, owing to failing health and press of business, he had not been able to be present at our meetings.

He was one of the original stock-holders of the Bristol Gas Company, and at the first meeting, in June, 1855, was elected Director, Superintendent, Secretary and Treasurer, which positions he held continuously, till the date of his death, in February, 1886.

He was also one of the original stock-holders of the Willimantic Gas Company, organized in 1859, and held the position of Manager in that Company until his death.

He was of a kind and genial disposition, retiring in his manner and faithful to every trust reposed in him. Honored by the citizens of his town, beloved and respected by all who knew him, when he passed to the "Land of the Living" he left behind an honored name.

Respectfully submitted,

S. G. STINESS,
W. A. STEDMAN, } Committee.

Mr. T. Fletcher's Lecture on "Curious Gas Flames."

In our last issue our English correspondent, Mr. Norton H. Humphreys, alluded to a lecture on "Curious Flames," delivered at a meeting of the Manchester Technical School, by Mr. T. Fletcher, F. C. S., of Warrington, England. It had been our intention to reproduce the lecturer's remarks in an earlier issue, but press of matter prevented us from so doing. Now, however, we take occasion to place the lecture before our readers, and premise the reproduction by giving the London *Journal* credit for our report of same. Mr. Fletcher, who was greeted by a large audience, spoke as follows:—

Flames and their peculiarities have not, up to the present time, received the amount of study which is necessary to understand them from a scientific point of view, or to utilize them commercially to the best advantage. Flame is really nothing but a sign of an incomplete or transition state of chemical combination. Its presence during combustion is not always necessary; and I think I am within the actual facts when I say that its presence under practical conditions in commercial use always indicates a loss of work. Many of the experiments I shall show you have been adopted as regular demonstrations at scientific lectures; and the details of these will be found scattered amongst different lectures of my own, but they have never been collected and classified so as to be utilized for a systematic study of the laws of flame and combustion, and enable a broad and general view to be obtained on this most important subject. The appearance of flame is misleading; and, as I will show you, the greater the flame, the smaller the work done, other things being equal. I have recently been asked by a well-known engineer if I could explain why certain boilers gave such an exceedingly small duty for the fuel consumed when the flues were, as he said, "filled from end to end with magnificent flame." The fact was his so-called magnificent flame was a delusion, hollow and cold inside, and not coming in contact with his boiler at all. When the fuel was burnt with a very small flame, hardly visible over the bridge, the duty increased some 30 per cent. I will now give you some practical demonstrations of the various characters of flames and their delusive appearances. A cotton handkerchief, as you, no doubt, are aware, will burn readily to ashes; and this I will prove to you by burning one. I have here another, precisely the same, which I will saturate with proof spirit; and, as you see, the flame, although apparently a fierce one, is not hot enough to ignite the handkerchief, which comes out of the fiery test without a singe or mark. The fact is that the flame is not only comparatively a cold one, but it is also hollow, and does not come in contact with the handkerchief at all; the space between the handkerchief and the flame being filled with cold vapor, which only burns when it comes into contact with the surrounding air. To make this internal space in a flame visible to you, I must experiment in a different way. I now take a burner 8 inches in diameter, supplied with a mixture of coal-gas and air; the air being supplied in quantity sufficient to increase the bulk of the flame, but not enough to enable the gas to burn except on the outer surface, where the mixture comes into contact with the surrounding air, with which it combines. This great flame is formed by the combustion of coal-gas at the rate of 2 cubic feet and about 20 cubic feet of air per minute. It is of very little use for any purpose; and I will now proceed to prove how great a delusion it is by placing a ball of paper inside it, then some loose gunpowder on an open paper, and again a ball of gun cotton, all of which remain untouched. The outer film of flame is hot enough to burn my hand if left in it; but if the body of my hand is protected with a damp cloth, I can, as you see, put my naked fingers inside the flame without discomfort, and pick the paper of gun cotton out of the centre of the flame. By an alteration of the burner, admitting sufficient air with the gas to form an explosive mixture, which will burn without assistance from the external air, the flame instantly becomes solid, much smaller, less visible, and at once explodes the gunpowder. If not the first to discover the peculiarities and value of a solid flame without a cold centre, the first application of this discovery to practical use was in Manchester by Mr. Wallace; and any mention of this valuable improvement would be incomplete without a reference to the name of so worthy a pioneer in the study of combustion. To reduce the flame to a still smaller size, a different form of burner is necessary, with a supply of air under pressure; and you now see the same quantity of gas and air burning, but the space taken up by the combustion, instead of being as at first 8 inches wide and 18 inches high, is less than 100th part the size; and instead of being able to put my bare hand in it, it will fuse wrought iron almost instantly. It is well known that the available duty of any source of heat is, other things being equal, in direct proportion to the difference of temperature between this source and the object to be heated; and, therefore, we shall get a much larger amount of work from our small high temperature flame than from the large and colder one. I will now dispense with flame altogether, and show you the same quantity of gas and air burning as before, but in the most perfect form; the combination taking place on the surface of the substance to be heated without any flame. To show this so that all can see, the mixture of gas and air is directed on a large ball of iron wire; flame being used at first to heat the wire to the necessary temperature to continue the combustion. By stopping the gas supply for an instant, the flame is extinguished; and the combustion

is now continued without any flame, but with an enormous increase in the heat obtained. This invisible or flameless combustion is only possible under certain conditions; and one essential point is that the combustible mixture shall come into absolute contact with a substance at a high temperature which is capable of absorbing the heat as it is generated. I will now heat this small furnace to a temperature sufficient to cause combustion without flame, and will then remove the side, showing you the interior of the furnace with a crucible being kept at a white heat by blowing a cold mixture of gas and air into it. In the absence of a solid substance at a high temperature, it is impossible to cause combustion without flame; and when a flame is used, it is also impossible to make it touch a cold surface. Many of you will imagine that if a solid body is surrounded by a flame, the flame touches it. This is altogether a mistake; there is a space between the two which it is impossible to pass—a cold and flameless zone which surrounds the cold surface, and which is quite impassable to flame under any conditions, and which most seriously obstructs the work of heating. To enable you to see that this impassable cold zone exists beyond any doubt, I have here a copper vessel containing water, and on the side of this vessel I have pasted a thin paper label. On this I will direct the powerful flame which you have seen will fuse wrought iron instantly, and the paper remains untouched, without a trace of singeing. The full force of the flame, urged by a heavy blast of air, may be directed on this paper for any length of time without the slightest effect, so long as the vessel contains any water. You will no doubt imagine that the heat is absorbed so quickly that the paper has not time to get hot; but it is very easy to prove that this is not the case by heating a wire in the same flame and touching the paper with it, causing instant charring. The cause of this extraordinary result has never yet been fully explained; but I believe it to be that all substances have an adherent film of air which resists the passage of any flame, but which is, of course, instantly removed by the application of any solid substance. This theory has one weak point, that the cold zone is impassable also to radiant heat; and in the face of this fact, I must say that a really satisfactory explanation is yet to be found which will agree with the present accepted theories of heat. The action of flame or heated matter on moist surfaces is much more easily explained. It is known that a moist hand or stick can be passed through molten iron without burning owing to the film of steam evolved, which prevents contact with the metal. The same reason accounts for the fact that I can burn gun cotton on my hand without feeling any heat, the moisture present absorbing the heat as fast as it is evolved. In the case of the paper label on the metal vessel, there is no moisture; the label having been carefully dried, to prevent the sudden formation of steam lifting it away from the metal surface. I think that the peculiar resistance to flame contact with a cold surface requires some further explanation than the present theories can account for. In connection with the subject of flames, I may refer, as a curiosity, to the enormous volume of sound of different tones which is produced by placing various sizes of chimneys on a gauze burner consuming a mixture of gas and air; the sound is as powerful, but certainly not so pleasing, as that of a fog-horn. In all my experiments ordinary air has been used to combine with the combustible materials—air being composed of four parts of nitrogen and one of oxygen. The nitrogen is quite inert, having no power to combine; in fact, it does nothing except dilute the oxygen, and reduce the temperature obtained. If we remove the nitrogen and use oxygen alone, the combustion is far more rapid and intense. So powerful is oxygen alone, that substances which are supposed to be incombustible—such as iron wire—burn readily in it. I have here a glass vessel full of oxygen, which is ordinary air with the useless nitrogen removed from it; and, as a final experiment, I will show you that iron, which is not usually considered a fuel, burns brilliantly in oxygen gas. In the combustion of iron, magnesium, and other substances of which the product is a solid, and not a vapor or gas, flame proper never exists; although in the combustion of magnesium and zinc it is apparently present. The brilliant incandescence of the particles thrown off causes a deceptive appearance. Flame never exists except as the result of the combination of two or more gases or vapors. As a familiar instance of both forms of combustion, there is no more striking example than coke or charcoal, which, if burnt at once to carbonic acid, burn entirely without flame. If the supply of air is deficient, carbonic oxide is formed, which, being a combustible gas, burns with a flame. When speaking of the properties of flame, I am on the borders of the unknown; and my experiments and knowledge of this subject are very incomplete. The study is to myself one of both business and pleasure combined; and I am still studying experimentally the cold zone or space which exists between all flames and cold substances to which they are applied. If this cold zone can be passed in practice, and the flames can be applied in direct contact with the vessels to be heated, we shall then obtain something approaching the full theoretical duty of the fuel consumed, and our waste of fuel will drop to a very small fraction. In a paper which I had the honor of reading before the Iron and Steel Institute, I referred to one problem in heating which, if solved, would reduce our waste of fuel to zero—*i. e.*, the conversion of a large bulk of heat of low intensity, to a smaller bulk of heat of high intensity. This conversion is possible with all other natural forces, such as light, electricity, etc.; and I believe it to be possible with heat also—the only objection being, so far as I can see, that we do not know how to do it at present. But I have no doubt that the time will come when this problem will be solved by some one, who will be rewarded by both fame and fortune.

The Velsbach Incandescent Gas Burner.

The JOURNAL, published on May 17, 1886, p. 290, contains an illustration and description of the incandescent gas burner that resulted from the studies of Dr. Auer (patented by him, in France, during November, 1885) von Velsbach, but which at the time did not seem likely to develop the somewhat extravagant claims of those interested in its ownership. From the best advice obtainable we fail to learn that the Auer plan of incandescent gas lighting has made much progress, in either France or Germany, during the twelvemonth; but we now have news that English capitalists have interested themselves in the Auer principle and apparatus. The following (which explains itself), from *Engineering*, will show the present standing of the Auer von Velsbach plan for obtaining improved illumination under the inventor's methods. It will be well to bear in mind that *Engineering's* mention of the "tested on a large scale in Vienna" instance should be taken with a liberal allowance of doubt, for the Vienna exhibition was of a decidedly limited nature. The paper noted, says:

The production of light for illuminating purposes by the incandescence of a refractory material has been the cherished object of many inventors, some of whom have so far developed their ideas as to have brought them more or less successfully from the laboratory into the market. The Clamond, Popp, Lewis, and more recently the Lowe and the Auer von Velsbach systems, are those of which we have heard the most, and which have found a more or less extended practical application. This last-named has been for a considerable time tested on a large scale in Vienna, and is now being somewhat tardily brought to the notice of the public in this country. Before Auer von Velsbach, a Viennese scientist, discovered a way to utilize one of the most refractory of known materials—zirconia—highly resistant earths and metals had been employed. Thus the Clamond system comprises the use of magnesia either in filaments, slabs, or pencils, against which the intense heat produced by a modified Bunsen burner is projected. Popp, Lewis, and Lowe, on the other hand, employ a cage of platinum, but in each of the two typical systems gas and air have to be supplied to the burner at exceptional pressures, involving special arrangements which complicate the process, and limit the range of their applications. With water gas such special arrangements are unnecessary, and we believe that at many factories in Germany, where water gas is made use of, the Clamond system is found to give satisfactory results. The pencils of magnesia, however, require very frequent renewal, and although the cost thus incurred is insignificant, the comparatively short duration of the incandescent material presents a very grave difficulty. In those systems, also, where cages of platinum wire are employed, the same objection applies with greater force, for not only does the platinum soften and absorb carbon under the continued action of intense heat, but the color of the light is not good, and the cost of renewal is relatively heavy.

The system of Professor Auer is one of extreme beauty and ingenuity. He extracts, by a complicated chemical process, the metal zirconia from one or other of the several zircon ores found in nature, and combines it in solution with solutions of lanthanum, and of one or more other rare and refractory metals, to obtain the basis on which his incandescent light depends. With the fluid thus produced he impregnates a hood of finely woven fabric, which, when dry, is suspended over a Bunsen burner and ignited; the combustible fabric is burnt away, the water of the solution evaporated, and there remains a delicate, an extremely delicate, zirconian counterpart of the original fabric, shrunk, of course, but perfect in every mesh. Prior to impregnation the top of the hood is secured by a fine platinum wire, which subsequently serves as a means of support, it being attached to a stem placed in the fittings of the lamp. The burner employed is of the Bunsen type, modified by an old and well-known device, so that it can be turned down without "lighting back," and the heat thus obtained, without any augmentation of pressure, is sufficient to bring the zirconia skeleton to a state of brilliant white incandescence, the luminous energy of the gas consumed in this way being considerably higher than when burnt in the most economical gas burner. As much as seven or eight candles per foot of gas burnt per hour can be obtained, though probably this is considerably higher than the average that would be given. There being no flame, the light is absolutely steady.

An installation of Velsbach burners has been erected at the Marlborough Gallery of Paintings, 53 Pall Mall, S. W., and awakens the admiration of all who see it, both for the absolute steadiness of the light, and for the beautiful quality of the illumination, which has a tone intermediate between that of an electric incandescence and an arc lamp. All the shades of green and blue in the paintings hung on the walls of the gallery come out with perfect accuracy, and it only needs the substitution of another source of light to render evident the great difference between gas burned under the Velsbach system and any other in vogue in this country. Fifty-six burners are arranged in two rows along the center of the room, and provide an illumination which is perfectly steady and noiseless, free from all dirt and smoke, and far less heating than usual, since little more than only one-third the ordinary quantity of gas per unit of light is consumed.

The burners at the Marlborough Gallery are, we believe, of the Austrian manufacture, but their production in this country is being attempted. Those we are describing are formed of a Bunsen burner having a gas jet on the principle of the watering rose—that is, with a number of small holes through which the gas is emitted in fine streams, which mingle with the air entering the mixing tube at the sides in the usual manner. This arrangement gives a short flame of great heat, and one which is quite free from all sound. The gas burns at the outlet of the mixing tube, within a hood or mantle formed of zirconia, as already described. This hood is made originally from hosiery fabric in the form of a tube, and is supported by a ring of platinum wire at its upper end. The tube is first doubled on itself, and then the wire is sewn into it, thus securing the hem and forming a means of attachment. By the aid of two extensions the wire ring thus formed is secured to a support, and the hood is held over the flame. According to another method of manufacture, devised by Mr. A. Paget, of Loughborough, the hoods are each made separately on a hosiery frame, and are provided with a channel, such as ladies call a string-case, at the upper edge. The platinum wire is threaded through this channel, and is provided with a cross hoop, like a bucket handle, by which the hood can be suspended from a hook. This arrangement gives a neat appearance to the hood, and causes the shrinkage to take place in a more symmetrical manner, avoiding plaits which may ultimately become sources of weakness owing to unequal temperature.

As the hood, after its incineration, is extremely fragile, it is necessary that it shall be protected as far as possible from the dangers of transport and handling. For this purpose the attachment from which it is suspended is fixed to a gallery, which forms the base of the chimney, and the three constitute a compact piece which can be moved safely. The hood cannot be unintentionally removed from the inside of the chimney, and the presence of the glass insures that reasonable care will be exercised in handling, even by ignorant servants. In connection with the gallery, which slides over the mixing tube of the burner, there is a grid which fits on the tube and prevents the flame striking back when the gas supply is reduced.

Experiments made on Monday last (Jan. 31) showed that with a consumption of 2.4 cubic feet of gas, at a pressure of 0.9 in. to 1 in. of water, an illumination of 18 standard candles was obtained, or an efficiency of 7.5 candles per cubic foot of gas. It is needless to say that this is a most successful result, and that if considerations of economy of consumption were the sole elements in the relation of gas burners, the Velsbach light must supersede all others. The question of the durability of the hood has, however, to be taken into account. Considering the very delicate nature of this part, which must not be subjected to rough usage of any kind, it is probable that in ordinary use comparatively few will perish of old age, but will be destroyed by accident. Laboratory experiments, however, show a duration of 1,000 hours, with but little reduction in the light-giving qualities, and we believe that 2,000 hours have been reached without remarkable deterioration. It is evident that if limits like these could be approached as an average, the cost of renewals would be insignificant, and the trouble involved inappreciable. But it is not likely that in common use, where the delicate film is exposed to careless and ignorant handling, and to all the thousand and one shocks of everyday life and work, that great longevity will be reached, and the items of cost and trouble may then enter as important factors in the equation of real usefulness. On the other hand, there is a large margin in economized gas, 50 per cent. is not too high an estimate, and this saving will balance damaged hoods and tired patience to a large extent, while an absolutely pure and steady light, a reduction in proportion to that of the gas consumed, in vitiated atmospheres, are no small advantages.

We believe that the Auer von Velsbach system has an extended field of usefulness before it, and that it will grow rapidly in favor in places where sufficient gas is burned to render it worth while for some with a capacity beyond that of domestic servants, to take charge of the fittings, and until it is challenged by some robust and equally efficient rival, which will defy the destructive finger of the British housemaid. The Velsbach system, with an actually, not relatively, strong hood would be practically perfect; it is for those interested in the question to arrive at this desideratum, and unless they can do so they can scarcely hope to hold a monopoly in gas lighting by incandescence, which promises to be, for a time at least, the "light of the future."

Mr. A. F. Upton Discusses Combustion.

At the Philadelphia meeting of the National Electric Light Association, Mr. A. F. Upton, of the Jarvis Engineering Company, Boston, Mass., presented and read a paper which contributed not a little to the interest of the Society's sessions. In referring to the subject of "Combustion," the writer said:

The subject of combustion of fuel is of sufficient importance among the electric light people to merit a few general remarks on the matter, for it is a

subject that is far less understood by steam users than anyone would suppose, considering the cost of the fuel consumed in making the steam in this country, and the following facts should interest all parties using steam power:

- 1st. That coal is distilled into gas before it can be properly burned.
- 2d. That to burn this gas, a sufficient supply of hot air must be introduced at a temperature not low enough to cool the gases below their igniting point.
- 3d. Every time a lot of fresh coal is thrown on the fire a great production of gas occurs, and if it is to burn to a flame it must have a corresponding supply of hot air. After a time, when the mass of fuel has become red-hot, the supply of gas is greatly diminished, and at first the evolution of gas actually checks the draught; but bear in mind that, although no smoke may be visible from the fire, it by no means follows that its combustion is perfect, for if you diminish the supply of hot air, or reduce the air space of your grate bars, you will be merely distilling carbonic oxide gas up the chimney.
- 4th. In ordinary boiler furnaces there is an insufficient supply of air; fresh coal is put on the grates, and the firing doors are closed; gas is being distilled from this coal. Now, if you do not furnish air above the fire (and it must be hot enough to ignite the gas), how can you expect to get combustion? Whether it is expected or not it does not burn properly, and your boiler furnace is nothing more than as a gas retort in a gas works, if the latter were making crude gas and wasting it up the chimney; in other words, a first class soot and smoke factory.

Therein we claim the principle of the Jarvis furnace to be correct. It does furnish pre-heated air to ignite and consume these gases, and make flame and heat otherwise wasted in the chimney; further, it allows of the use of fuel or a class of fuels that, in an ordinary furnace, will produce little else than soot and smoke.

As most boiler furnaces are constructed they are nothing else but gas producers—that is, all gas producers are extra bad stoves or boiler furnaces. Consider how ordinary gas is made. There is a red hot retort or cylinder, into which you shovel a quantity of coal, which flames and smokes vigorously as long as the door is open; when it is full of coal you shut the door cutting off the supply of air and extinguishing the flame. Gas is now simply distilled, and passes along pipes to be purified and stored. You perceive at once that the difference between a gas retort and an ordinary boiler furnace, with closed doors and half choked grate bars, is not very great.

Consumption of smoke, using bituminous coal: It is not a so-called "smoke-burner" you really want; it is a fuel consumer. You distill your fuel instead of burning it in nine-tenths of your boiler furnaces. There is no such thing as "burning smoke." Once made it cannot be burnt, and the only way I know of burning it is not to make it.

The question of supplying hot air, and the amount to be supplied at the right time, is a question that has puzzled the most scientific men who have made a study of this most important question. The Jarvis furnace is so constructed that the damper regulates the amount of air delivered into the boiler. If the full force of the draught of the chimney is required, then the open damper allows a full supply; a half damper gives one-half the supply; and if the damper is closed no air enters the furnace over the fire. Every first-class steam plant should use a steam damper, and with such a damper the feed of hot air is perfectly automatic. The Jarvis furnace for setting steam boilers is constructed in the following manner.

It is on the same principle as the Siemens-Martin furnace for making steel. In a different manner, and on a smaller scale, we pre-heat air (oxygen), and discharge it over and back of the fires, thus utilizing and igniting gases generally wasted. The joining of hot air with gases creates a draught, and allows the combustion of low-grade fuels that would otherwise require a draught to burn. Smoke is reduced to a minimum by this process. If the fuel is wet it is an advantage where hot air is used.

The principal thing to my mind in regard to electric lighting is the cost of power. I have always claimed from our experience that the matter of power in this regard was figured, in one sense, on a wrong basis. My idea is, to get at the bottom of all economy in electric lighting, the cost of power should be most carefully looked at. The only thing to be considered is the actual cost per lamp per hour, not evaporation of pounds of coal per hour. It is the actual cost of running an incandescent or arc lamp per hour.

The only money to be made in the future in electric lighting under the coming competition is to be made in saving. Reduce the cost of fuel; use only the cheapest and lowest cost grades. Why use the highest cost coal when slack coal, screenings or pea coal can be purchased at one-half price, and, with proper furnaces, evaporate the same amount of water as the highest grades of coal?

REFUSED TO FIX THE PRICE.—The "gas reformers" of New Jersey introduced a bill during the present session of the Legislature, which sought to make an arbitrary rate (\$1.25 per thousand) for gas in certain New Jersey cities. The bill was defeated, on March 9.

Notes from the West.

By RETORT.

FEBRUARY 28, 1887.

After tremendous surface indications all is again quiet and serene at Cincinnati; and, as usual, the Gas Company emerges from the conflict with that same old smile. Even the public benefactors claim to be happy! The Gas Company will now enter upon its new 10 years' contract to furnish gas at \$1.25 per thousand, with 10 cents discount for prompt payment; making the new rate (\$1.15) a very happy compromise, and a price that will make a tremendous increase in the output. The fight has been a very pretty one, and reflects great credit upon the "fine Italian hand" that managed the Gas Company's case. Coming at this time, it insures freedom from competition, for the city is engaged in putting down four million dollars' worth of new pavements; and, as a leading paper asserts, will only allow it to be disturbed for the conduits for natural gas.

Capt. A. H. Mattox, whom those of the fraternity met while attending the Cincinnati Convention of the Western Association in 1883, will remember with so much pleasure, and who has been for twenty years a valuable attaché of the Cincinnati Gas Company, has tendered his resignation to Gen. Hickenlooper. Capt. Mattox has taken the position of General District Superintendent for a prominent Life Insurance Company, and will have his headquarters in Cincinnati. The retiring official was presented, on February 25, with a handsome gold watch and chain by the employees of the Cincinnati Gas Company.

A new deal seems to be on the tapis in St. Louis, Mo., as the following will show:

"Another move has been made in the gas matters of the city, in the acceptance of the resignation of Mr. C. H. Nash, as General Manager of the St. Louis Gas Works. Mr. Nash was the water gas representative in St. Louis, and has been a prominent figure in all the deals made by the Philadelphia United Gas Improvement Company. He quietly bought a large lot of St. Louis stock, one block in particular occasioning some feeling and considerable comment, for the United people, before the formation of the Trust agreement, and during the time the St. Louis and water gas bills were pending in the Municipal Assembly. Then he went into the market and bought up nearly a control of the Kansas City Gas Light Company for the United, and when enough to answer his purpose was bought at \$750 a share, several times the market value, he went to Kansas City to capture the organization, but failed through not having the stock transferred. Still, he took more prominent position with the United, and when the St. Louis Gas Trust was formed Soc. Newman remained as the President and nominal head of the old St. Louis Company, but Mr. Nash, at the request of the water gas interest in the Trust, was made General Manager of the St. Louis. His resignation, followed by the arrival in the city of Mr. S. T. Bodine, Secretary and Treasurer, and Mr. A. C. Humphreys, Engineer of the United Gas Improvement Company, is thought to be significant in more ways than one.

"Representing the water gas interests, Mr. Nash's plans as manager of the St. Louis Gas Light Company are supposed to have been sanctioned by the Philadelphia interests, and the rejection of his suggestions which brought about his resignation, is thus made the rejection of the water gas plans. The reason given for Mr. Nash's resignation is that only work of a trifling nature was to be done, and, with his large works at St. Joseph on his hands, he regarded his services as too valuable to be wasted under the present policy. The water gas plans anticipate an entire change in the plant of the St. Louis Gas Light Company, the erection of new coal gas works, with such improvements and parts of machinery of other methods of manufacture as to enable the Company to change its process if desirable and utilize the water gas patents."

Comment on the above is unnecessary.

Sometime in February the City Council of Xenia, Ohio, awarded a contract to the Xenia Gas Company, by which the city was to turn over to the Gas Company the electric light plant owned and operated by the municipality the Gas Company to furnish electric lights in the suburbs, but the city was still to be lighted, in its central part, with gas, at the rate of \$26 per year per post. The city now attempts to annul its former action, and has taken legal steps to secure a perpetual injunction against the Gas Company, and restraining the Council from fulfilling its contract. A hotly-contested lawsuit seems to be inevitable, with a final settlement through the courts.

Proving or Testing Meters.

The *Gas Engineer* says that in testing gas meters one great essential is a good 10-foot experimental gasholder, with an accurate scale divided into feet, which are again subdivided into tenths and hundredths. The holder should be provided with counterbalance weights, so that its pressure may be controlled at will from 1-tenth to 20-tenths. In addition it should have a separate large weight detached and suspended by a cord, which is lowered and

raised when desired by a kind of windlass, so as to give the very heavy pressure necessary to prove the soundness of the cases of meters. The holder should also be provided with its counterbalance weights and compensating curve. The first is for the purpose of regulating the pressure, the second is to "compensate" for the difference of pressure arising from the holder when being in the water and out of it.

To understand the importance of the compensating curve, let us suppose a holder of the capacity of 10 feet, that its working range is 3 feet, and its area 3 feet 4 inches square, and that the weight of the sides in the length stated is 10 lbs. Now, as in round numbers iron is about eight times heavier than water, it follows that when the holder is submerged in the tank one-eighth of its weight would be lost, and its weight would, under the circumstances, be but 8½ lbs., which, indeed, with the weight of the top and the part out of the water added thereto, would be the required weight to balance the holder when in the water. But as the holder rises out of the tank, gradually its weight increases until it reaches its highest position, when by the metal of the sides, which has emerged, a weight of 1½ lbs. has been added to the holder, or equivalent to a pressure of 2-tenths. Therefore, to compensate for this the most simple contrivance is the curve already mentioned; but as its description would not interest the general reader it is omitted. However, should any of our subscribers desire to know the means of setting out the compensating curve, it will be explained in a future issue.

The holder is provided with two taps of large dimensions, so as to admit the gas freely and quickly; also a small blow-off tap, by which, in the event of the holder being too full, it may be lowered to the desired point by the tap in question. All these taps are placed together, and within easy reach of the operator. The inlet of the holder is, of course, connected to the gas supply. The outlet has a flexible tube at the end of which is a screw for receiving the respective cone pieces, according to the size of the meter being tested.

Another requisite is a bench or slab placed perfectly level. A slate slab of about an inch thick, with a gutter all round its edges, so as to carry off any water, is well adapted for the purpose. At the side of this slab is a tank of water with a bench across it for the purpose of charging wet meters.

In addition there are a number of burners attached to the same tube, placed against the wall, and about six feet from the ground, which are in direct communication with the meter to be examined. Of these there are one or more Argands, with their glasses properly cleaned, in order to ascertain the steadiness of the lights when a dry meter is examined. Here, we may observe, that on account of the construction of the wet meters, little doubt can exist about the steadiness of the lights supplied by it. Whereas, with the dry meter, even supposing everything else to be correct, the "ital" of the tangents might render the lights unsteady, therefore steadiness of lights is one point of consideration with them.

ITEMS OF INTEREST FROM VARIOUS LOCALITIES.

THE PROPRIETORS OF THE SHANER GAS COAL COMPANY.—Some time since we noted that a party of Pennsylvania capitalists had organized the Shaner Gas Coal Company, and from the certificate of incorporation filed in the office of the Recorder at Pittsburgh, Pa., we learn that the capital stock of the Company (\$250,000, par value of shares being \$50 each) is owned by the following-named gentlemen: C. Donnelly, W. McCandless, C. S. Spear, J. S. Cravens, and W. A. Clemens each hold 500 shares; J. D. McKennan, 1,000 shares; and C. C. Dickey, 1,500 shares.

DESTRUCTION OF AN ELECTRIC LIGHT STATION.—Shortly before 7 A.M. of March 4 the two-storied frame building located on Condor street, East Boston, Mass., occupied as a dynamo station by the Citizens Electric Light Company, was discovered to be on fire. The building (it was valued at \$1,200) was destroyed, and considerable damage was done to the dynamos. East Boston will, in consequence, be deprived of its electric lighting for a time; but the omission will not "fall heavily" upon the citizens, for the gas lamps stand ready to occupy the gap.

THE PAWTUCKET (R. I.) FOLKS WILL TRY IT.—The special committee recently appointed by the Pawtucket Gas Light Company to consider the expediency of placing an electric light plant in the Company's old works at Central Falls, decided, on March 3d, to report in favor of the proposition. The findings will have to be ratified at a meeting of the Board of Directors; but it is likely the latter body will endorse the special committee's presentation of the subject. In fact the plans, specifications, and estimates are all prepared, so that the work may be carried out immediately after the Board's indorsement.

TO BURN ALL NIGHT.—At a recent meeting of Richmond (Va.) City Councils the Committee on Light recommended that the public lamps be lighted at 15 minutes after sunset, and extinguished 15 minutes prior to sunrise on

each night of the year. A moon table schedule is at present followed, and it would appear as if Richmond were old enough now to emerge from the easy-going practices of the *ante lucem* period.

TO ERECT A HOLDER.—The Standard Gas Light Company, of this city, proposes to erect a gasholder (to have a diameter of about 100 feet) on the south side of 115th street, 100 feet East of Pleasant avenue.

MR. ATTRILL WOULD RATHER NOT.—The New York *Times*, of March 8, says that Judge Donohue, of the Supreme Court, on March 7, granted an injunction to counsel for Mr. H. Y. Attrill restraining Melville C. Day, and other executors of the estate of Commodore C. K. Garrison, from selling stock of the Equitable Gas Light Company, Baltimore, Md., belonging to Mr. Attrill, and held by them as security for money which they claim to be due from him to the estate. This, of course, is a relic connected with the Garrison-Attrill gas deals in Baltimore, New Orleans, etc., when gas raiding in this country was in its infancy. Of course the future will take care of itself; but many a rich hour's work is in store for the legal fledglings of the present day, when the period for constructing some of the present gas pools, consolidations, leases, etc., will have arrived. Perhaps even some of the older lights of the bar may have a seat at the feast.

THE NEW YORK CITY SUBWAYS.—Those of our readers who are interested in the matter of the compulsory underground placing of electric lighting and other wires, will remember the triumphant entree of the Hon. Roswell P. Flower into membership in the New York City Board of Subway Commissioners; and they will also recollect his grand exit therefrom. The Hon. Commissioner had solved the problem in short order, by granting to some high-fangled company the concession to construct a subway where Dorsett, *et al.*; conduits were to be availed of by all companies and individuals interested in the ownership and operation of wires for the transmission of various electric currents. Having solved the problem, the Commissioner resigned his trust and returned to his banking house, feeling assured that the plows of the subway owners would never rest until the streets (or some of them) of New York had taken on a furrowy appearance. It is true that the plows did assist in furrowing a portion of Sixth avenue, but winter's ruthless grip suspended the bucolic operation. Not only so, but it seems to have laid its icy hand upon the spirit of those who furnished the means wherewith to operate and guide the implements of husbandry. We incline to that view because of Corporation Counsel Lacombe's paternal connection with a bill which proposes to foist upon the city the duty of operating all subway conduits. His measure intimates that the city may purchase those (subways) already constructed, or it may build others; and in case the bill becomes a law it is safe to say "those" already down will be purchased. In fact it is patent that the original owners of the subway privilege do not want to throw good money after bad; not only so, but that it would be prudent, statesmanlike, and romantic to "make an effort" to get the bad money turned into good by means of an alchemic resort to the city's treasury.

THE WEBER FURNACES.—Mr. Adam Weber is as busy as ever. In a recent letter to us he says that, among other work, he is now erecting new benches, to be fired with his improved system of regenerative furnaces, for the following companies: A new stack of eight benches of sixes for the Buffalo (N. Y.) Mutual; five benches of sixes, Citizens, of Buffalo; four benches of sixes Buffalo Gas Light Company; one bench of sixes at Lynn, Mass.; and one bench of sixes at North Adams, Mass. In the four last-named cases the settings were made in old arches. The Weber system of firing continues to please those who have already tried it. For instance, the Supt. of the Buffalo Citizens Company reports a saving of one-third of the fuel expended under the old firing practice. The Supt. of the gas works at the buildings of the New York Catholic Protectory reports that he is obtaining from 7,500 to 8,000 cubic feet per mouthpiece each 24 hours, from settings of threes, placed in short benches with narrow arch.

BERMUDA'S PLEASANT BREEZES.—Mr. Wm. R. Beal, President of the Central Gas Company of this city, is enjoying a well-earned vacation among the tropical surroundings of the Bermuda Islands. He will return to the city some time in April.

ENLARGING ITS POSSESSIONS.—A fortnight ago we noted that the Springfield (Mass.) Gas Light Company was in search of an eligible plot of ground whereon to locate a new gasholder. This has since been accomplished by the purchase of two plots, known respectively as the Shaw and Parsons properties. The latter plot contains a brick dwelling house, which will hereafter be occupied as a residence by Mr. A. D. Merritt, Assistant Supt. to the Company. The Shaw land has been chosen for the holder site. The purchases represent an investment of about \$10,000. The new holder is to have a capacity of 300,000 cubic feet, which, with the Bliss and Water street holders, will give the Company storage facilities aggregating 600,000 cubic feet.

GRAND FORKS (DAK.) OUGHT TO BE SATISFIED.—A month ago we noted the formation of a new gas company for the town of Grand Forks, Dak. Ter. It was an error, in that we did not state the case in extenso. Grand Forks seems likely to have two gas companies, because on the third inst. work was commenced on the plant of the Grand Forks National Gas Company, likewise on the structures of the Dakota Gas Company. Both parties have contracted for apparatus and mains, and have purchased the necessary land. Each side claims to have plenty of capital; but the Grand Forks proprietors have a contract with the city, which would seem to give them a substantial advantage in the rivalry.

TO LEAVE NEBRASKA CITY, NEB.—Mr. J. M. Murphy, who for sometime past has occupied the position of Supt. of the Nebraska City Gas Company, resigned that berth towards the close of February, in order to take a responsible place in the service of the Maryland Meter Company, of Baltimore. A rather handsome reminder of the niche he occupied in the esteem of his fellow townsmen was vouchsafed the retiring Superintendent by them on the evening of February 26th. The reminder took the shape of a banquet at the Morton House, which was participated in by the "solid men" of Nebraska City. Perhaps the feeling that prompted the feast is best shown by the following excerpt from the Nebraska City *Press* in its account of the affair: "We believe we are safe in saying that Mr. J. M. Murphy could have asked no more graceful compliment or fuller recognition of the affection and esteem in which he is held by his friends than that accorded him last evening at the Morton House; and it is just as certain that those having the matter in charge could have found no more fit subject to honor with the compliment of a banquet than Mr. J. M. Murphy. It was a delightful affair in all respects." Mr. F. E. McMillin is to assume the office made vacant by Mr. Murphy's resignation.

TO FURNISH ELECTRIC LIGHT.—We are informed that the managers of the Municipal Gas Company, Albany, New York, have determined to operate an incandescent electric lighting plant in conjunction with the gas supply. Our present advices do not intimate the particular system that is to be adopted.

RETORTS FOR THE QUAKER CITY GAS WORKS.—Mr. Jas. Gardner, Jr., whose recent trip to the ever faithful Isle appears to have agreed with him amazingly, writes that he has just secured a contract to furnish 90 benches of fives to the Market street station of the Quaker City gas works.

FINANCIAL STANDING OF THE MIDDLETOWN (OHIO) GAS COMPANY.—From an inventory recently filed with the County Clerk we learn that the Middletown Gas Light Company estimates its property to be worth \$35,477; it owes \$2,193; and its assets and liabilities balance at \$37,781. The authorized capital stock is \$60,000.

THEY WANT TO SEE THE BOOKS.—A committee of the stockholders of the McKeesport (Pa.) Gas Light Company assert that they are preparing to bring suit against the officers of the Company to compel them to open the books for inspection. The malcontents claim that the profits are absorbed by the high salaries paid the officials.

STREET LIGHTING AT CIRCLEVILLE, OHIO.—At a recent meeting of the Circleville City Council bids for street lighting were opened. Three propositions were made. The Gas Company offered to light 137 lamps, guaranteed power of 16 candles, at \$18 per post per annum, contract to last, at option of Council for one or five years; the electric light company offered to supply 16-candle power incandescent lights at price bid by the gas company, but wanted a five-year contract. Jones & Underhill of Columbus, offered to light with kerosene at \$10 per lamp. The contract was awarded to the gas men. A moon-table is followed at Circleville.

LOWELL'S CHEAP GAS.—The new gas rate at Lowell, Mass., of \$1.20 per thousand cubic feet, goes into effect on April 1st.

AT LAST IT IS SETTLED.—Some time back we noted that the net gas rate in Cincinnati, Ohio, was to be \$1.25 per thousand cubic feet. It seems, however, after the thing was supposed to have been settled, that a new proposition was substituted; but there can be no doubt about the correctness and finality of the following statement in regard to the net rates to prevail during the next ten years for gas in Cincinnati. The gross price is fixed at \$1.25 per thousand, with ten cents off for prompt payment. Not so far from the dollar notch; is it?

MANAGERS OF THE ALBANY (N. Y.) EDISON COMPANY.—At the election (March 4) of managers for the Edison Electric Illuminating Company, of Albany, Henry R. Pierson was chosen President; James M. Warner Vice-President; Edgar Cottrell, Secretary; J. W. Eaton, Jr., Treasurer; James MacNaughton, Supt. and Manager.

IN CHARGE OF THE FULTON MUNICIPAL WORKS.—Mr. J. H. Jourdan, who, if we mistake not, is the son of ex-Police Commissioner Jourdan, of Brooklyn, is acting as Superintendent of the Fulton-Municipal Gas Company. It will be remembered that Mr. Geo. O. Knapp, formerly in charge of the works mentioned, resigned the position last December to take charge of the Equitable Company's works in Chicago, Ills.

CHANGING THE BUFFALO (N. Y.) METHOD OF STREET LAMP ASSESSMENT.—At a meeting of the Buffalo City Fathers the following resolution, reported by Gen. Graves, was adopted:

"The Common Council shall cause to be raised yearly a sufficient amount of money to defray the expense of lighting and maintaining the lamp district, and keeping the pipes, lamp posts, lamps and other fixtures in repair; one-half of which amount shall be included in the general tax, and paid out of the general fund; the other half shall be apportioned by the Comptroller pro rata per foot front upon the frontage of all the taxable land in the lamp district, as set down in the assessment rolls; and the said lamp tax shall be set down in a separate column of the general tax roll, to be headed 'lamp tax,' and shall be levied upon the lands aforesaid and collected accordingly, omitting from corner lots the tax on side streets to the depth of 100 feet."

A HANDSOME STRUCTURE.—The Chesapeake Gas Company has completed its office and meter building, located on Bayard street, South Baltimore, Md. The structure is 40 by 60 feet, two stories in height, and built of brick, ornately finished in terra cotta trimming. The President's and Supt.'s offices are handsomely finished in oak, and in fact everything about the place has been completed with proper regard to utility, permanence and harmony. The station meters, two in number, calculated to a maximum duty for both of something less than five millions cubic feet per diem, present a massive and handsome appearance. The photometer and laboratory departments are in keeping with the general character of the establishment.

DEACON OBERGLOCK DID NOT BELIEVE IN GAS METERS.—Alas! that we should be called upon to report that another "Deacon" has been found wandering astray from the walks of the righteous; not only so, but this particular shepherd seems to have revelled in iniquity. Flatbush anyway seems to enjoy, at any rate to possess, a wide heterogeneity in the matter of its residential population. On the one hand we see numerous staid and solid descendants of the thrifty Hollanders who discovered the beauties of the location, some two hundred years ago, and on the other we note that Kings county there has placed the institutions in which it cares for its pauper classes. Then, again, a year or two ago the adjacent counties were treated, through the medium of the courts, to a wonderful series of revelations concerning the osculatory practices carried on by members of what afterwards became known as the Flatbush "Kissing Club." However, we do not believe that Deacon Oberglock is to be put down either as a descendant of the Hollanders, an inmate of the county institutions, or as having figured on the membership lists of the "Club." He seems to have followed the peaceful avocation of a country merchant, whose practices in trade compelled the use of a stove, and the employment of a glue pot. Flatbush has a gas company whose affairs are largely intrusted to the charge of Mr. W. A. Armington, and that gentleman is wide-awake, energetic and clever. In common with his uncle, the worthy President of the Brooklyn Gas Light Company, young Mr. Armington is a thorough believer in keeping his unaccounted-for-gas charges down to the lowest possible figure; and latterly he had reason to think that something was wrong with the Flatbush Company's pipes. A hunt after "leaks" was accordingly instituted, and the inspector finally traced an important defect to the vicinity on which fronts the store of Deacon Oberglock. The inspector evidently fails to be a thorough believer in "Deacons," for, despite the Oberglock demurrer, the examiner entered upon the premises of the righteous. The deacon in question never had paid toll to the local gas company—that is, in the past—his meek and lowly habit being amply sated by the glimmer of a candle, or the glare of the kerosene, while his stove gave out the warmth afforded in the combustion of anthracite coal, or an occasional application of coke. The inspector's unerring eye, while calmly surveying the cellar walls of the Oberglock sanctuary, perceived that a false connection had been made to the company's mains, from which a rubber tube led up to the apartment overhead. Following the tube the investigator found that its final destination was in the service to a gas stove in the Deacon's kitchen, as also at the bottom of a glue pot. The inspector reported the "find" to his superior, and Supt. Armington subsequently verified the survey. The Deacon acknowledged his lapse from grace, and immediately offered to settle, whereupon he was presented with a bill amounting to upwards of \$300. We presume it will be in order now for the Deacon to make a hegira to "pastures green and fields anew" (possibly he may try to live it down), and if he does betake himself to other quarters it is more than likely that he will prove a most valuable and loud-voiced recruit to the ranks of the "indignant consumer class." We would

respectfully call the attention of "Dr. Robinsen, of Columbus," to the possibilities involved in the latter suggestion.

INCREASING THE CAPITAL STOCK.—The Edison Electric Light Company of this city, at a meeting held on March 2, decided to increase its capital stock from 12,942 to 16,000 shares. It is said the increase will be devoted to a purchase of the franchise, sold by the parent company to the Western Electric Light Company, for the States of Illinois, Ohio, and Wisconsin. The Company has been under the impression that it made a mistake in selling the rights mentioned, and will now repurchase them.

SWAPPING GAS STOCK FOR A RACE TRACK.—It is said that the City Council of Atlanta, Ga., has ordered the Finance Committee to sell 600 shares, or so much thereof as may be necessary, of the stock owned by the city in the Atlanta Gas Light Company, in order to raise the sum of \$15,000, which is to be expended in the erection of suitable buildings on the grounds of the "Gentlemen's Driving Park Association," to be used for the holding of the yearly fairs given under the auspices of the Piedmont Fair Association. Better have kept the gas stock, gentlemen; for that description of security may always be regarded as a "sure thing."

MAKING IT LARGER.—If capital increase counts as an indicator, the Edison Electric Illuminating Company, of New Bedford, Mass., must be "doing quite well." On the last day of February the managers of the concern increased the capital stock to \$100,000, an addition of 100 per cent.

An Electric Light and Power Company has been incorporated to do business in the village of Greenport, L. I. It is capitalized in \$12,000.

CHICAGO'S PUBLIC LIGHTING ORDINANCE.—The Chicago (Ill.) City Council has passed the gas ordinances. The north and south side ordinances give the Companies the right to charge \$1 per thousand cubic feet for gas supplied to the public lamps. Burners rated to pass four feet per hour are to be used, and the lighting schedule of last year is to be followed. The west side ordinance provides for the same burners and lighting schedule adopted for the other divisions, but the Companies are to receive \$1.50 per thousand for the gas. Last year the west side lamps were maintained in accordance with a moon table. [The west side portion of the ordinance has been reconsidered.]

ONE OF THE POSSIBLE "SNAGS" IN THE JOINT PROPOSITION.—The following from the Providence (R. I.) *Journal*, of Feb. 26, will shew how local independent electric light suppliers may interpose an obstacle to the joint supply of gas and electricity by gas companies: "The House Committee on Corporations (Rhode Island Legislature) held a hearing, on the rising of the House yesterday, on the petition of the Providence Gas Company for amendment of charter allowing them to erect an electric light plant, and use the same for lighting and heating purposes, as in the case of the grant to the Pawtucket Gas Light Company last year. The two local electric light companies also presented arguments asking for an extension of their charters which would allow them to make and distribute gas. The Providence Gas Company, through its President, said that the Company intended to take advantage in every improvement of a practical nature in lighting, whether by electricity or any other means not yet developed, and would do so for the benefit of its 2,000 stockholders, among which were represented many trusts and fiduciary interests. The representatives of the local electric companies said they would make no opposition to the Gas Company's request, provided they (the electricians) were allowed to make and distribute gas. The committee held the matter for advisement."

VISALIA (CAL.) TO HAVE LIGHT.—Grants were given last February for the separate operation of gas and electric light companies in the town of Visalia. These conflicting interests have been consolidated in a single corporation, to be known as the Visalia Gas and Electric Light Company. It is proposed to construct the gas plant without delay. Visalia is the capital of Tulare county, Cal., is 62 miles (by rail) southeast of Stockton, and 6 miles east of Goshen Station, on the Southern Pacific Railroad. Population, about 4,000. It is quite eligibly situated.

IT FAILED TO PASS THE LOWER BRANCH.—Senator Spoener's pet project to restrict the price to be charged for gas in the District of Columbia to the net figure of \$1 per thousand cubic feet, having passed the Senate, was not acted upon in the House of Representatives. Now that they are trying to charge ex-Speaker Randall with all the misdeeds of the last session of Congress, perhaps the "indignant" Washington consumer had better join in the chorus, "It's all Randall's fault." Mr. Senator Spoener must feel sadly cast down.

TO RECOVER DAMAGES.—On the 22d of January the shot tower of the Gulf Shot and Lead Company, of New Orleans, La., was destroyed by fire. Investigation as to the cause of the disaster proved that the conflagration was caused by imperfect insulation of the electric light wires that entered the

building; and after much cogitation the proprietors of the Company, on February 28, entered suit against the Brush Electric Light Company for \$17,100 damages, plaintiffs claiming that the negligence of the Brush Company's managers made them responsible for the loss incurred.

TALKING OF A RIVAL GAS COMPANY IN MANCHESTER, N. H.—Our Manchester advices contain the information that a corporation, to be known as the Peoples Gas Light Company, has been organized under the general laws of the State, for the purpose of manufacturing, distributing, and selling carburated hydrogen gas in the city of Manchester. The new Company is capitalized in \$100,000, and the parties interested, nominally at least, are said to be Messrs. N. W. Ellis, A. Elliot, J. F. Briggs, F. Dewat, and J. B. Varick. The certificate of incorporation was filed on Feb. 28th, and the Manchester City Council, on the following Tuesday, gave the incorporators permission to pipe the streets. Various reasons are assigned for the opposition movement, but we fail to see how any of them can be regarded as valid, for the old Company has performed its duty to the people in every respect. A 20-candle gas is sold there at a net rate of \$1.50 per thousand, and the gas plant is ample for any demand likely to be made on its resources. The capital invested is but \$100,000; and, take it all-in-all, we imagine that the newcomers will experience much trouble in making any impression on the value of the Gerould stronghold. There is but one way in which to conquer the old Manchester Gas Light Company, and that would be by a fair purchase of a controlling interest in its capital. Still that operation would be an expensive one, for we think the last transaction in its shares was effected at a premium close on to 300 per cent.

NOTICE OF REMOVAL.—Mr. George H. Gregory, the proprietor of the Retort Gas Lamp, is now located at No. 389 Broadway, this city. His former address was No. 337, same thoroughfare.

ANNUAL MEETING, BOSTON (MASS.) GAS LIGHT COMPANY.—At the annual meeting of the Boston Gas Light Company (held March 9) the following Board of Directors was elected: Messrs. Augustus Lowell, Augustus Flagg, Chas. H. Parker, Nath. J. Rust, and Louis Curtis. Mr. Augustus Lowell was chosen President; Mr. W. W. Greeneough, Treasurer; and C. C. Smith, Clerk.

DEATH OF MR. JAS. H. WALKER, SR.—We regret to announce the decease of Mr. Jas. H. Walker, Sr., whose demise occurred, at Tonawanda, N. Y., on the 1st inst. Deceased was well known to the fraternity. He was at one time in the service of the Milwaukee (Wis.) Gas Light Company; later on he had charge of the Citizens works at Rochester, N. Y.; and at the time of his death was Supt. of the Tonawanda Company's plant. Deceased was in his 59th year.

A Substitute for Coal.

The London *Journal* explains that an invention of considerable interest to all consumers of coal has been brought out by Mr. Sahlstrom, of the Normal Company, Aberdeen, and is at present in operation at the Company's works. After a long series of experiments the inventor has succeeded in producing a fuel which gives most satisfactory results. It is described as having for its basis pitch oil, in combination with superheated steam decomposed by an agent, the nature of which he does not at present wish to divulge. The invention, which has been in practical use in the Company's works for some time past, is stated to effect a saving of nearly 30 per cent. in the cost of fuel. It is considered possible that even better results may be attained with a specially constructed boiler. The one at present in use was built for a coal fire, but has been adapted by Mr. Sahlstrom to receive the oil fuel. The arrangements for feeding the fire are exceedingly simple and convenient. On a shelf raised about 4 feet above the level of the floor stands a small tank, having a graded attachment to shew the quantity of oil drawn from it within a given time. From this tank (which is replenished when necessary from a larger one) a pipe leads downwards to the furnace, and is joined there by another pipe, which conveys the decomposed steam to its union with the oil at the jet, both being fed automatically. The volume of fuel supplied is governed by means of a small tap fixed near the furnace, and easily controlled by the attendant. The rapidity of the combustion is so great that a heat of upwards of 3,000° is attained. Mr. Sahlstrom claims three special advantages for his process. First, its cheapness; secondly, that it is absolutely smokeless; and thirdly, that the combustion is complete—every portion of the heat contained in the fuel being utilized. In addition to these, it has a manifest superiority over coal in the matter of cleanliness, and in the number of attendants required—one man being sufficient to look after as many oil fires as would necessitate the employment of three or four where coal is used. Mr. Sahlstrom is confident that the introduction of his process into foundries would be attended with the greatest success, as the intense concentration of the heat would permit the use of smaller melting ovens. In the furnace now in use wrought iron can be melted in 15 minutes.

The Market for Gas Securities.

Absolute stagnation characterizes the situation in the local gas share market. During the fortnight a slight "boom" was developed in Consolidated, during which period the highest price touched was 86; but subsequently the specialty sagged off. Appearances indicate that Consolidated is decidedly a purchase at the present time. Equitable is at 125 or thereabouts, and is strongly held. Brooklyn transactions are smaller than ever, in fact sellers and buyers are waiting upon the Legislature. It is curious to note how well disposed the present Legislature seems to be towards gas proprietors. Perhaps they sorrow over the way in which they settled the New York case. The Chicago deal seems to be disposed of, with the possible exception of "adjusting" gas rates. It is a trifle amusing to note the assertions in some of the Chicago despatches eastward, which claim that Mr. Watkins disposed of his holdings so precipitately as to lose nearly \$500,000. Perhaps he did; but somehow or another the impression prevails that if anybody got over 170 for his stock Mr. Watkins was that fortunate individual. At the sale of the Atlanta (Ga.) gas stock held by the city, par and over was realized. The shares were bought by those who knew their value.

Gas Stocks.

Quotations by Geo. W. Close, Broker and Dealer in Gas Stocks.

16 WALL ST., NEW YORK CITY.

MARCH 16.

All communications will receive particular attention. The following quotations are based on the par value of \$100 per share.

	Capital.	Par.	Bid	Asked
Consolidated.....	\$35,430,000	100	84	—
Central.....	440,000	50	30	—
“ Scrip.....	220,000	—	47	57
Equitable.....	2,000,000	100	126	128
“ Bonds.....	1,000,000	—	113	115
Harlem, Bonds.....	170,000	—	—	—
Metropolitan, Bonds....	658,000	—	110	113
Mutual.....	3,500,000	100	102	103
“ Bonds.....	1,500,000	1000	101	—
Municipal, Bonds.....	750,000	—	—	—
Northern.....	125,000	50	30	—
“ Scrip.....	108,000	—	—	—
Yonkers.....	—	50	51	55
Richmond Co., S. I.	300,000	50	50	—
“ Bonds.....	12,000	—	—	—
Gas Co's of Brooklyn.				
Brooklyn.....	2,000,000	25	104	—
Citizens.....	1,200,000	20	—	68
“ S. F. Bonds....	320,000	1000	—	103
Fulton Municipal.....	3,000,000	100	135	—
“ Bonds....	300,000	—	—	106
Peoples.....	1,000,000	10	54	56
“ Bonds.....	290,000	—	100	—
“ “.....	250,000	—	100	—
Metropolitan.....	1,000,000	100	78	80
Nassau.....	1,000,000	25	102	104
“ Cifs.....	700,000	1000	100	—
Williamsburgh.....	1,000,000	50	125	—
“ Bonds... ..	1,000,000	—	107	—
Out of Town Gas Companies.				
Boston (Mass.) Gas Co.	2,500,000	500	870	875
Buffalo Mutual, N. Y....	750,000	100	90	95
“ Bonds... ..	200,000	1000	95	100
Citizens, Newark.....	1,000,000	50	140	145
“ “ Bonds.	45,000	—	—	—
Chicago Gas Co., Ills... ..	5,000,000	25	142	145
Peoples G. L. & C. Co.,				
Chicago, Ills.....	3,000,000	—	29	31
Cincinnati G. & C. Co..	6,000,000	100	184	185
Consolidated, Balt.....	6,000,000	100	58½	—
“ Bonds....	3,600,000	—	107	107½
Chesapeake, Balt.....	1,500,000	100	79	80
“	1,000,000	—	100	102
Consumers Toronto....	1,000,000	50	194½	196½
Central, S. F., Cal.....	—	—	82½	84
Capital, Sacramento, Cal.	—	—	55	58
Hartford, Conn.....	750,000	25	140	142
Jersey City.....	750,000	20	155	—

Laclede, St. Louis, Mo.	1,600,000	100	110	112
Louisville, Ky.....	2,570,000	50	130	132
Little Falls, N. Y.....	50,000	100	95	100
“ Bonds	25,000	—	100	103
Montreal, Canada.....	2,000,000	100	209	215
New Haven, Conn.....	—	25	190	195
Oakland, Cal.....	—	—	35	36
Peoples, Jersey City... ..	—	—	25	30
“ “ Bonds..	—	—	—	—
Paterson, N. J.....	—	25	90	—
Rochester, N. Y.....	—	50	75	80
St. Louis, Missouri.....	600,000	50	—	475
San Francisco Gas Co.				
San Francisco, Cal....	10,000,000	100	60¼	60½
Memphis (Tenn.) Gas... ..	750,000	100	80	82
“ Bonds.	240,000	100	103	—
Washington, D. C.....	2,000,000	20	190	—
Wilmington, Del.....	—	50	205	215
Havana (Cuba) Gas Co.	3,000,000	100	18	20
“ Bonds....	550,000	—	102	—

ENGAGEMENT DESIRED
As Superintendent of Coal or Water Gas Works.

Has had years of experience in manufacture or distribution of gas and construction of works. Satisfactory references furnished. Address "E." care this Journal.

WANTED,
By a practical man of many years' experience,
A Position as Superintendent of a Small Gas Works in a Growing Town,
where experience will be of value. Salary not so much an object. Best of references Address 663-1 "R. A.," care this Journal.

ALBO-CARBON FIXTURES FOR SALE.
Three 12-Burner, Two 8-Burner, and Fourteen 6-Burner Clusters.
All in good order, having been used but six months. Will be sold cheap. For particulars communicate with E. G. PRATT, Supt. N. Attleboro Gas Lt. Co., 660-2t North Attleboro Mass

SUPERINTENDENT'S POSITION DESIRED.
By a practical gasfitter and competent bookkeeper, who has had entire management of coal and water gas plants. Satisfactory references furnished. Address 665-3 "B.," care this Office.

Superintendent's Position Desired
By a practical man of twenty-five years' experience in the manufacture and distribution of coal and water gas. Satisfactory references given. Address 646-tf "ENGINEER," care this Office.

SUPERINTENDENT'S POSITION WANTED
By a practical manager of coal and oil gas works, of 22 years graduation in all the departments—viz., distribution, manufacture, and secretary's duties. Also has a partial knowledge of electric lighting. Satisfactory references given. Address 665-tf R. HORTON, care this Office.

FOR SALE,
Two Sinuous Friction Condensers
Each 1 ft. 3 in. wide by 11 ft. 3 in. long, and 18 ft high, of sufficient capacity for 225,000 cu. ft. per day. Apply to 665-12 PETER COFFEY, Supt Gas Co., Peoria, Ill.

FOR SALE,
Ten No. 2 Siemens Regenerative Gas Lamps,
With Factory Fixtures and Reflectors complete and in order. Only used three or four months. Will be sold cheap. DANVILLE NAIL AND MFG. CO., Danville, Pa.

GAS WORKS FOR SALE.
A RARE CHANCE.
The owner will dispose of the controlling interest in a gas works in a growing Western city, on account of declining health and inability to attend to the business. For particulars address 665-6 P. O. Box 825, Appleton, Wis.

Bouton Foundry Co.,
FOUNDERS AND MACHINISTS,
CHICAGO, ILL.
Gas Works Apparatus,
PURIFIERS, CONDENSERS,
Bench Work,
SPECIALS, LAMP POSTS,
SCRUBBERS,
Iron Roofs and Floors.
Plans and Estimates furnished for new works or extensions of old works.

JARVIS ENGINEERING CO.,
61 Oliver St., Boston, Mass.
CONTRACTORS FOR ERECTING
COMPLETE STEAM OUTFITS FOR ELECTRIC LIGHTING STATIONS.
Steel Boilers set with Jarvis Pat. Boiler Setting,
To burn COKE SCREENINGS for Fuel.
ARMINGTON & SIMS CO. ENGINES,
Belting direct to Dynamos, without using Shafting.
SEND FOR CIRCULARS.

Ferric Oxide for Gas Purification.
Ferric Oxide, as ground, screened, and prepared by me for purifying purposes, has now been in use for several years by many of the gas works throughout the country, including Detroit, Chicago, Milwaukee, East Saginaw, Burlington (Iowa), Ann Arbor, etc. It has proved, as I believe, the Most Effective and Economical Agent now in use. I am prepared to furnish the Oxide by the 100 lbs. or in car load lots, and will be pleased to give price f.o.b. cars at Ann Arbor or at place of destination. Address S. H. DOUGLAS, Prest. Ann Arbor (Mich.) Gas Light Co.

MITCHELL, VANCE & CO.,

MANUFACTURERS OF

Chandeliers

and every description of

GAS FIXTURES.

Also manufacturers of Fine Gilt Bronzes and Marble Clocks, warranted best time-keepers. Mantel Ornaments, etc.

Salesrooms, 836 Broadway, N. Y.

Special Designs furnished for Gas Fixtures for Churches, Public Halls, Lodges, etc.

THE GLOBE STREET LAMP.



MINER'S PATENT STREET LAMPS.

Are adapted for use of Streets, Parks, Depots, Ferries, & Private Grounds.

WITH POSTS OR BRACKETS.

Jacob G. Miner,

No. 823 Eagle Ave., New York N. Y.

"RUSTLESS" IRON WATER PIPE.

RUSTLESS Send for New Catalogue. **RUSTLESS**

The **WELLS RUSTLESS IRON COMPANY**,
Nos. 7 and 9 Cliff Street, New York City.

GASHOLDER TANK CONSTRUCTION, ETC.

Gas Companies and others about to erect Gasholders will find it profitable to consult W. C. WHYTE, who for over thirty years has made a specialty of

Holder Tank Excavation and Mason Work.

Fifty tanks now in operation show the sort of work done. Address

W. C. WHYTE, No. 15 Cortlandt St., N. Y. City.

CHURCH'S REVERSIBLE SCREEN FOR GAS PURIFIERS

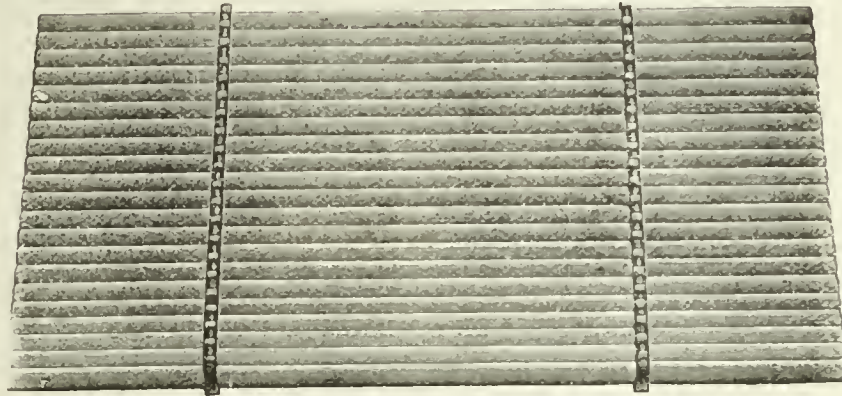

Very Durable
Easily Repaired.

Oval Slats, with
Malleable Iron
Cross Bars.

Apply to

JOHN CABOT,

306 to 310 11th Av., N. Y.

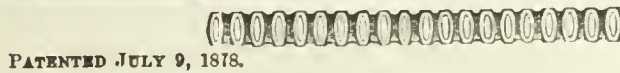

PATENTED JULY 9, 1878.

References in all parts of the country. Send for circular and list of companies who now have the Screen in use.

THE KERR MURRAY MANUFACTURING COMPANY, Fort Wayne, Ind.

CONSTRUCTING ENGINEERS AND BUILDERS OF

GAS WORKS AND HOLDERS.

Drawings, Estimates, and Specifications Furnished for the Construction of New and the Rebuilding of Old Works.

MANUFACTURERS OF LATEST IMPROVED APPARATUS FOR COMPLETE AND AUXILIARY OIL AND WATER GAS PLANTS.

Rotary and Steam Jet Exhausters, Rotary Washers, Self-Sealing Mouthpieces,

HYDRAULIC LIFTS FOR PURIFIER COVERS.

"VALVE COMBINATION" FOR OPERATING ONE TO FOUR OR MORE PURIFIERS.

Street Specials, Valves, and Fittings.

COKE CRUSHERS, COAL AND COKE WAGONS, LAMP POSTS.

Iron Roofs, Cutters, and Retort House Floors.

STEAM ENGINES AND BOILERS, IRON COAL SHEDS.

Single and Telescopic Gasholders.

Correspondence is Respectfully Solicited.

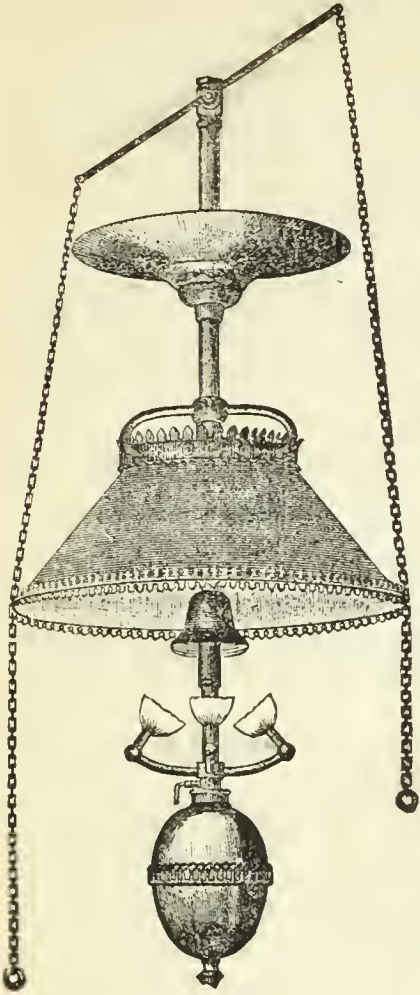

THE ALBO-CARBON LIGHT!

The Perfection of Gas Lighting.

Producing the Highest Illumination yet obtained from Gas, and
EFFECTING A SAVING IN ITS CONSUMPTION.

It has been most effective in

Replacing Electricity,

AFFORDING A

SOFT WHITE LIGHT
 of **EXTREME BRILLIANCY & POWER.**

It has been most successful in

Supplanting Kerosene,

Giving Increased Light, Less Heat, and Perfect Safety
WITHOUT ADDITIONAL COST.

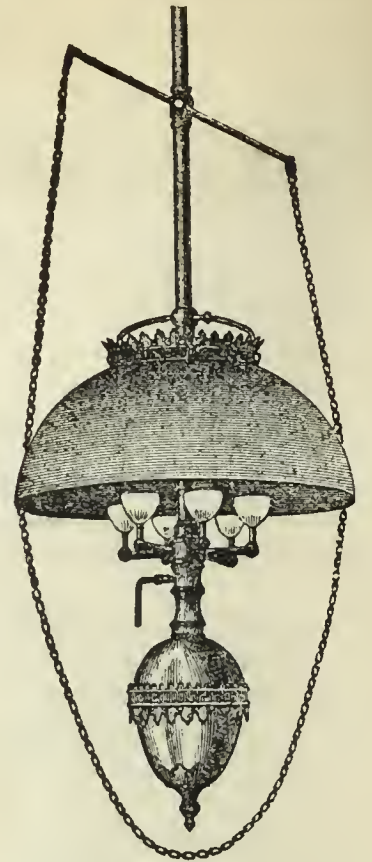

has come up for hearing, and an injunction has been granted therein. The second of said suits has not yet been reached for hearing. All persons are cautioned against manufacturing, selling, or using any apparatus or material which infringes our Patents. We intend to prosecute all parties infringing patents owned by us.

THE ALBO-CARBON LIGHT COMPANY, - - - NEWARK, N. J.
 Sole Manufacturers for the United States.

DURING THE PAST YEAR, THE

NATIONAL GAS LIGHT AND FUEL CO.

218 LA SALLE ST., CHICAGO,

Have Erected Twelve Sets of Water Gas Generating Apparatus under the
Springer Cupola System. They are as follows:

Newton Illuminating Company, Newton, Kansas.— Daily capacity, 120,000 cu. ft.

Wellington Light & Heat Co., Wellington, Kansas.— Daily capacity, 120,000 cu. ft.

Chippewa Falls, Gas Light Co., Chippewa Falls, Wis.— Daily capacity, 120,000 cu. ft.

Elkhart Gas Light & Coke Co., Elkhart, Indiana.— Daily capacity, 120,000 cu. ft.

Madison City Gas Light Company, Madison, Wis.— Daily capacity, 120,000 cu. ft.

South Bend Gas Light Co., South Bend, Indiana.— Daily capacity, 250,000 cu. ft.

Sheboygan National Gas Comp'y, Sheboygan, Wis.— Daily capacity, 120,000 cu. ft.

Salina Gas Light Company, Salina, Kansas.— Daily capacity, 120,000 cu. ft.

Rathbun Company, Deseronto, Province Ontario.— Daily capacity, 80,000 cu. ft.

Jefferson City Gas Light Co., Jefferson City, Mo.— Daily capacity, 120,000 cu. ft.

Mankato Gas Light Company, Mankato, Minnesota.— Daily capacity, 80,000 cu. ft.

Minneapolis Gas Lt. & Coke Co., Minneapolis, Minn.— Daily capacity, 1,000,000 cu. ft.

1886

1886

Kloenne & Bredel Improved REGENERATIVE FURNACES

Self-Sealing Mouthpieces and Bridge Pipes,
RETORT HOUSES, WASHER-SCRUBBERS
GASHOLDERS, AND GAS WORKS COMPLETE.

Our system of heating retorts by regenerative furnaces is the simplest, most economical, most durable, and cheapest of any in use. It is the only regenerative furnace used to any extent in Great Britain, where several thousand retorts are working at the present time. In Birmingham alone 952 retorts were erected, and they are giving the best satisfaction ever obtained from any regenerative furnaces. The great advantages our benches have over all others are the following:

The generator and regenerator are independent of each other, so that any contraction or expansion of one will not interfere with the other.

The superheating surface is greater than in any other furnace yet constructed. The regenerator is absolutely self-tightening, and cannot get out of order.

The thickness of material between the wastegases, secondary and primary air is only 1½ inches, which increases the regenerative power from 100 to 500 per cent.

The generator is working absolutely cold, and therefore is not liable to any perceptible wear and tear.

The grate, having an enormous surface, allows the use of an inferior fuel, such as breeze, fine coke, or slack coal.

Clinkers are never formed. By an ingenious arrangement of mixing air and the steam produced by the cooling water all incombustible materials in the fuel are formed into soft ashes.

The waste gases go up through flues at 400° to

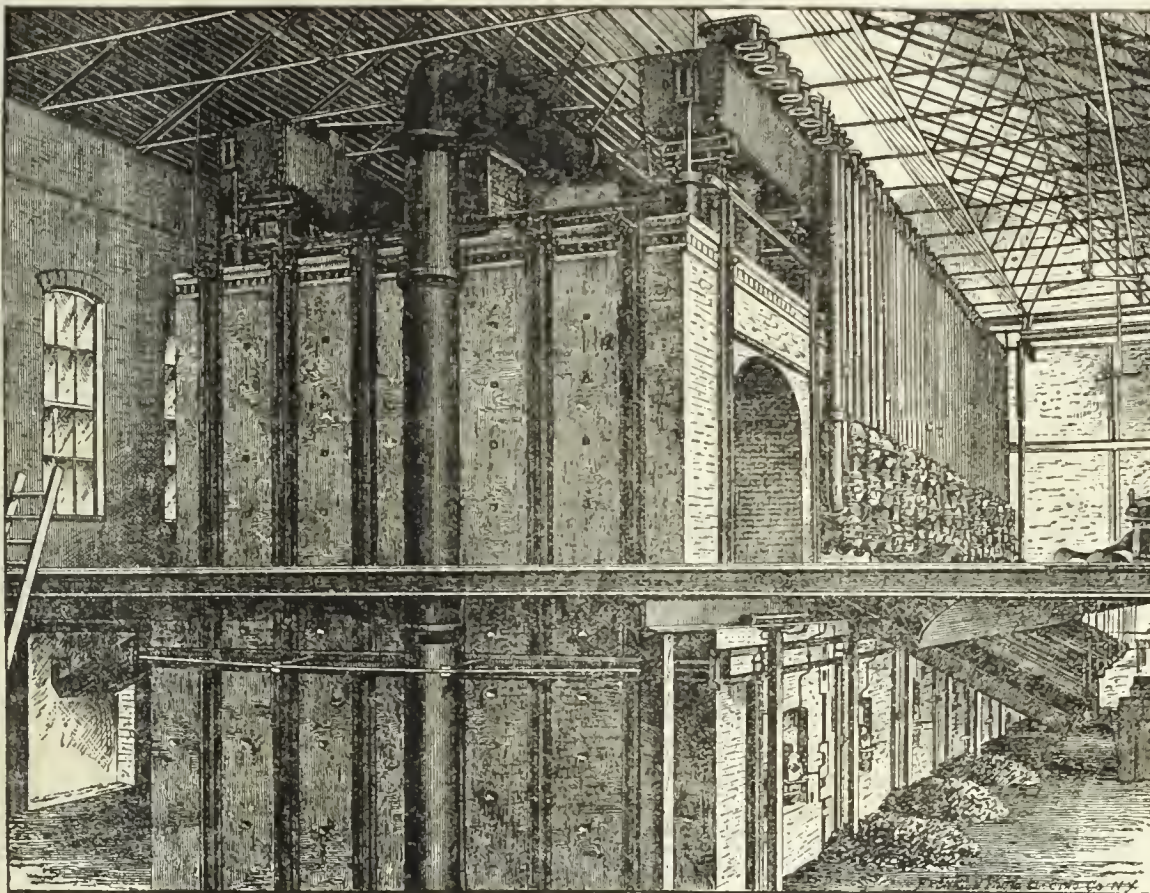

500° F. No large chimneys are required.

No cold air can enter; consequently no cracking of retorts.

The generator is inside of bench, thereby preventing any loss of heat; and stokers do not have to stand on a hot floor, as is the case where the generator projects outside of the bench.

In the past two years more than 500 retorts, with a capacity of five million cubic feet of gas per diem, have been erected in this country, and these are giving the best satisfaction, as the following testimonials will show.

We also construct half-regenerative benches, which will give the best results, and can be built in existing skeleton arches.

OFFICE OF THE NEWARK GAS LIGHT COMPANY, NEWARK, N. J., January 28, 1887.

MR. FREDERICK BREDEL, General Agent Kloenne Regenerative Furnace:

Dear Sir—The Kloenne Furnaces erected by you have been in continuous use for more than a year, and continue to give us satisfactory results. We are carbonizing 1,800 pounds coal per retort in 24 hours, and the average fuel consumption for this much has been 16.8 pounds by volume of the coke produced, or 100 pounds coal have been carbonized by 11.25 pounds hot coke. We have not lost a retort yet, and I think that those in use will give us six months' more service.

Very truly,

[Signed] EUGENE VANDERPOOL.

ENGINEER'S OFFICE, MILWAUKEE GAS LIGHT COMPANY, MILWAUKEE, WIS., January 26, 1887.

FRED. BREDEL, C.E.: Dear Sir—Upon your request for a testimonial for publication, I am pleased to send you the following, as I consider it deserved for the way in which your contract was carried out with us. I would say to any in the profession that among all the plans of benches presented to me from which to select I chose the "Kloenne" for several reasons. I considered it perfect in principle, that at all times it would be under absolute control, and also that each block in the regeneration could be easily seen and repaired if necessary. Your work upon our benches was done as good as it possibly could have been by anyone, and such has been the opinion of the several visitors during the progress of the work and since its completion, without exception. We have been running the furnaces since Oct. 6, and as yet have observed no cracked or sagged retorts. Every part of the work appears as perfect as when set. Although the first month was used up in experimenting and learning how to run the furnaces, and since that time we have experienced very cold weather, yet we are selling 26 bushels of coke (40 lbs. per bushel) per net ton of coal used. The consumption of coke in the furnaces does not exceed 20 per cent. at the present season, and for the year I am sure will be materially less.

Yours truly,

[Signed] E. G. COWDERY.

OFFICE OF THE CHICAGO GAS LIGHT AND COKE COMPANY, CHICAGO, ILL., January 27, 1887.

FRED. BREDEL, Esq.: Dear Sir—We have had eight benches of nines with the Kloenne furnaces running continuously for 13 months. The results have averaged 9,000 cubic feet per mouthpiece in 24 hours, with a fuel consumption of 13 pounds coke per 100 pounds coal carbonized.

Yours truly,

[Signed] THEOB'D FORSTALL, V.-P.

For further information apply to

FRED BREDEL,
332 East 17th Street, N. Y. City. } OR { **G. F. KREISCHER,**
132 Mangin Street, N. Y. City.

GAS ENGINES.

GAS LAMPS.

BOOKS.

THE CLERK GAS ENGINE CO.,

Main Office, 1012, 1014, 1016, 1018 Filbert St., Philadelphia, Pa.

WM. W. GOODWIN, Prest.

E. STEIN, Sec.

S. LEWIS JONES, Asst. Sec.

A. J. DOTY, Supt.

The utility and convenience of the Gas Engine being no longer an open question, it only remains now for intending purchasers to select the BEST. We claim for the CLERK GAS ENGINE that it is equal to any other manufactured as regards steadiness in running, simplicity, and ease of keeping in repair, and that it gives the greatest amount of power for the least money (both in first cost and expense of running) of any engine made. In support of this claim we refer to the test of the Gas Engines made under the direction of the American Institute of New York, in December, 1885, and heretofore published in these columns. These engines are especially adapted for continuous running under heavy loads, and we can refer to Engines which have run 22 hours a day for months at a time.

Made in Sizes of 5, 10, 15, 20, and 25 Horse Power. All Engines Guaranteed for One Year.

TRADE MARK.

THE CRYSTAL CARBON LIGHT!

The Latest and Most Improved Gas Light!

ADAPTED FOR PRIVATE RESIDENCES, CHURCHES, THEATERS, STORES, ETC.

These Burners are manufactured on the principle of enriching gas by means of Naphthaline (so-called Crystal Carbon or Albo-Carbon), the invention of the Rev. W. R. Bowditch, F.R.S., of Wakefield, England, who was the original inventor and patentee of this system of gas lighting.

SPECIAL NOTICE.

Many Gas Companies find the Crystal Carbon Light a valuable competitor against the Electric Light. It is ornamental, free from the defects common to all other enriching gas burners, and is as cheap as ordinary gas chandeliers. We sell direct to gas companies, giving them the benefit of agents' discounts.

CARBONCRYSTAL.

(Trade Mark.)

A new and superior preparation for enriching gas used in conjunction with Crystal Carbon or Albo-Carbon gas lights.

The preparation is cleaner and better adapted for filling burner vessels than any hitherto produced.

Guaranteed to be chemically pure. Supplied in cans from 10 pounds up.

THIS IS THE CHEAPEST AND PUREST FORM OF ENRICHING MATERIAL.

CRYSTAL CARBON LIGHT CO.,

Main Office, No. 1018 Chestnut Street, Philadelphia, Pa.

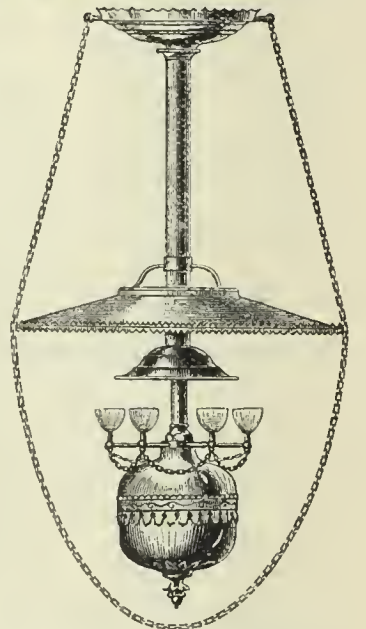

C. W. HUNT CO.,

No. 111 Broadway, N. Y. City.

MANUFACTURERS OF

Coal Handling Machinery,

AUTOMATIC RAILWAY, HOISTING ELEVATOR,
CABLE RAILWAY, STEAM SHOVEL, HOISTING
ENGINES, COAL TUBS, COAL & COKE CARS.

Plans and Specifications made for the

Erection of Coal Storage Buildings

Send for a Descriptive Pamphlet.

GAS vs. ELECTRIC LIGHT.

We would invite attention to the able and exhaustive argument of General A. Hickenlooper, President of the Cincinnati Gas Light and Coke Company, contained in a handsome pamphlet of 96 pages, entitled

"EDISON'S INCANDESCENT ELECTRIC LIGHTS FOR STREET ILLUMINATION. REPORT OF AN ARGUMENT DELIVERED BY A. HICKENLOOPER BEFORE THE COMMITTEE ON LIGHT, MUNICIPAL COUNCIL, CITY OF CINCINNATI, JULY 22, 1886."

This is a subject of special interest to all Gas Light Companies.

Prices.

25 copies.....	\$7.50	100 copies.....	\$22.50
50 copies.....	12.50	250 copies.....	50.00

A sample copy will be sent by mail on receipt of 50 cts.

A. M. CALLENDER, & CO., 42 PINE ST., N. Y. CITY.



STEPHEN A. MORSE, President.
GODFREY REBMANN, Vice-Pres.

M. B. DYOTT,
Superintendent.

EDWIN F. MORSE, Secretary.
CARLTON M. WILLIAMS, Treas.

STANDARD GAS LAMP CO.,

Office, 411 Cherry St. Factory, 1101, 1103 & 1105 Frankford Av.

Philadelphia, Pa.

It is to the interest of Gas Companies and Cities to use Dyott's Patent Champion Lamps, which give double the light with the same consumption of gas, and will save 50 per cent. over others in cost of keeping in repair. Gas Companies and others intending to erect Lamps of any description will do well to communicate with us. Special Drawings furnished and Estimates given on application upon Architects', Engineers' or our Draughtsmen's Plans.

Our Patent System of Instantaneously Lighting Gas (without electricity) for R. R. Depots is unequalled. Our High Candle Power Burner is superior to the Electric Light or any other High Candle Burner. We manufacture every description of Ornamental Lamps.

WONDERFUL GAS LIGHT!

Great improvements! New inventions! Brilliant success! Brilliant light!

Over 500,000 of the Gas Lamps and Burners designed by GEO. H. GREGORY now in practical use. Send for Catalogue. Prices reduced on all goods in order that Gas Companies will introduce the goods to the consumer at a reasonable price. Over one hundred Gas Companies are selling the new lamps and burners. The only way to prevent the adoption of incandescent electric light is to put on the wonderful gas lamps and burners. Address

GEO. H. GREGORY, Gas Lamp and Burner Mnfr., 389 BROADWAY, N. Y.

GAS EXHAUSTERS

Have long been regarded as "luxuries" not to be thought of by small companies; but

CONNELLY'S JET EXHAUSTER IS WITHIN THE REACH OF ALL!

Will Pay for Itself in Six Months! Saves Labor! Lengthens the Lives of Retorts! Prevents the Formation of Carbon!
Increases the Yield from Twelve to Fifteen Per Cent.!

We find, after careful inquiry and investigation, that the majority of the Gas Works in the United States and Canada are running *without Exhausters*, which, in our opinion is due to two causes. *First.* The prices heretofore asked for Exhausters have been so high as to counteract, to a great extent, the advantages to be obtained from their use, and caused most managers to postpone their adoption indefinitely, or until their consumption had largely increased. *Second.* Many superintendents have a false impression that it will not pay to run an Exhauster in works producing less than 20,000 feet per day.

The first difficulty we overcome by selling our Exhausters at *extremely low prices*, as will readily be admitted after comparing our list with those of other manufacturers; and as to the second, we can say we have most convincing evidence from many companies operating our Exhausters that they can be used to advantage in works producing *as low as 6,000 cubic feet per day*.

In our improved Exhauster we combine the "Exhaust Tube" Gas and Steam Governors, Gas Compensator, and Bye-Pass Valves in the most compact form possible, which is a very great advantage to the machine, besides enabling us to manufacture and sell at the low prices given.

This is the only Exhauster in the market having a "compensator" in addition to the "gas governor"—a most important improvement, as it does away with all possible danger of their ever drawing air, and thus reducing the illuminating power of the gas.

FOR OIL GAS WORKS.

Our Exhausters are especially adapted for the use of Oil Gas Works; and where oil is required to dilute the gas a valve can be adjusted to *take the exact amount of air required*, thus dispensing with air pumps and their attendant labor and annoyance.

POINTS OF SUPERIORITY.

Requires *one-half the floor space* and *one-third less steam* than any other Exhauster in the market of same capacity. *More cheaply and easily connected*, as outside "Bye-Pass Valves" are dispensed with. It is the only Exhauster manufactured having "Compensator" and "Governor" *combined*, the "Compensator" with all other Exhausters being a separate and distinct machine. It is simple in construction, easily adjusted, not liable to get out of order, and *can be operated by ordinary workmen*.

NAPHTHALINE AND STEAM JET EXHAUSTERS.

As many superintendents of Gas Works believe the use of a Steam Jet Exhauster will inevitably cause trouble from *naphthaline* deposits, we recently sent out letters of inquiry to superintendents using our Steam Jet, asking for their experience, and the following replies speak for themselves. That naphthaline deposits are often unjustly attributed to Jet Exhausters is well known by many superintendents. When the cause cannot be determined it seems to be the rule to place the responsibility on the Jet Exhauster, *if they have one*; but if no Exhauster is used *the cause remains a mystery*.

OFFICE LISTOWEL GAS LT. CO., LISTOWEL, CAN., May 29, 1885.

Messrs. Connelly & Co., Ltd.: Gentlemen—The Exhauster purchased from you over three years ago, and now in use, has proven in every way all you claim for it, and has given us great satisfaction. No trouble has arisen from naphthaline.

Yours respectfully, F. W. HAY, Sec.

RICHMOND GAS CO., RICHMOND, KY., June 1, 1885.

Messrs. Connelly & Co., Ltd., 407 Broadway, N. Y.: Gentlemen—I put in your Steam Jet Exhauster last November. I think it a perfect machine, as it requires no attention whatever. Have not had any naphthaline to contend with; it would be very easy to get rid of that substance if I had it.

Yours very truly, J. B. GORDON, Supt.

HAMPTON, VA., June 3, 1885.

Messrs. Connelly & Co., Ltd.: Gents—We have been using your Steam Jet Exhauster for the past 3 years, and have never had any trouble with it whatever, either from naphthaline or any other source.

Yours truly, J. B. H. GOFF.

BRUNSWICK, ME., May 27, 1885.

Messrs. Connelly & Co., Ltd.: Dear Sirs—Your favor of 23d inst. at hand. In answer would say your Exhauster works well with us. We make an oil gas; are not troubled with naphthaline. Very truly yours, B. G. DENNISON, Prest. Brunswick Gas Lt. Co.

WILMINGTON, O., June 15, 1885.

Messrs. Connelly & Co., Ltd.: Dear Sirs—We started your make of six-inch Steam Jet Exhauster March 30, and I am pleased to state, from the time the steam was turned on, it has performed its work to our entire satisfaction. We have never had any other but a Steam Jet Exhauster, and have never been troubled with naphthaline. For many reasons I prefer it to the "rotary," and have no hesitancy in recommending it.

Yours truly, E. W. HAMLIN, Sec. Gas Co.

OFFICE LOGAN GAS LT. & COKE CO., LAGAN, HOCKING CO., O., May 29, 1885.

Connelly & Co., Ltd.: Gentlemen—In answer to yours of 27th we have to say that the Steam Jet Exhauster put in for us by you last fall has been used constantly since, and, up to this time, we have had no trouble with naphthaline. We have heard many gas men say that a Steam Set Exhauster is liable to bring on trouble with naphthaline, and we have had that fear before us; but so far we have escaped, and we trust we may not have any experience with that gas manager's bugbear.

Yours truly,
LOGAN GAS LT. & COKE CO.

OFFICE ATHENS GAS LT. CO., ATHENS, O., May 30, 1885.

Messrs. Connelly & Co., Ltd.: Dear Sirs—We take pleasure in giving you an unqualified endorsement of your Steam Jet Exhauster. It has been in place almost a year; been tested in all seasons and under all conditions; it has always proved true to the work assigned it. We have had no naphthaline deposit, nor any trouble chargeable to the Exhauster. Nothing but good has come from it, and great good at that. We can't do without it.

Very truly yours, C. H. WELCH, Supt.

OFFICE MEADVILLE GAS WORKS, MEADVILLE, PA., May 29, 1885.

Connelly & Co., Ltd.: Gents—Yours of the 27th received and contents noted. Would say that after using your Steam Jet Exhauster for the past 18 months, find it perfectly satisfactory in every way. So far as naphthaline is concerned, we have had no trouble whatever as yet.

Yours, GEO. S. CULLUM, Supt.

NYACK AND WARREN GAS LT. CO., NYACK, N. Y., May 25, 1885.

Connelly & Co., Ltd.: Gentlemen—Since your Jet Exhauster has been here there has been no trouble, and certainly *no naphthaline*. The only trouble I have experienced was the Jet becoming clogged with tar last week, and I cleaned it in a few minutes. It has run over three years without any trouble or cost for repairs.

Yours truly,
A. MURRAY, Lessee and Manager.

OFFICE CADIZ GAS LT. CO., CADIZ, O., May 29, 1885.

Messrs. Connelly & Co., Ltd.: Gentlemen—Yours of 23d, inquiring how our Steam Jet Exhauster is doing, has been received. We have been using one of your Exhausters about four years, and with the best of satisfaction. We have less trouble with carbon in retorts, make more gas from same amount of coal than before, and have no trouble with stoppage in pipes or trouble from tar; and as regards naphthaline, we are not troubled with it, and do not know what it is to have any stoppage in pipes from naphthaline.

Very truly yours, A. N. HAMMOND, Sec.

SIDNEY (OHIO) GAS WORKS, June 1, 1885.

Connelly & Co., Ltd.: Gentlemen—We have now been using one of your Steam Jet Exhausters about five months, and thus far it has given us perfect satisfaction. We get a better yield and a more brilliant quality of gas from the coal. We have seen in papers and heard from different individuals that Steam Jet Exhausters were productive of naphthaline. "We can't see it," as we have found no trace of it in the works, mains, services, or meters.

Respectfully yours, W. W. GRAHAM, Supt.

CONNELLY & CO., LTD., No. 177 Broadway, New York City.

T. C. HOPPER'S.
AUTOMATIC DIFFERENTIAL GAS GOVERNOR

Is now in Practical Operation, doing Perfect Automatic Service with Great Precision.

This Governor will do all and more than any other Governor on the Market.

BE SURE TO THOROUGHLY INVESTIGATE THE SUPERIOR MERITS OF THIS GOVERNOR BEFORE PURCHASING.

For Simplicity and Reliable Work it has no Equal. Correspondence Solicited.

T. C. HOPPER & CO., - - Manufactory, 2227 Wood Street, Phila, Pa.

LUDLOW VALVE MFG. CO.

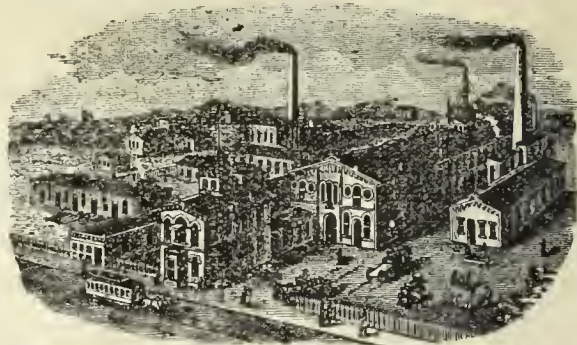

OFFICE AND WORKS,
938 to 954 Elver Street and 67 to 83 Vail Av.
TROY, N. Y.

Hydraulic Main Dip Regulators, also
Check Valves, Foot Valves, Yard-
wash and Fire Hydrants.
Send for Circulars.

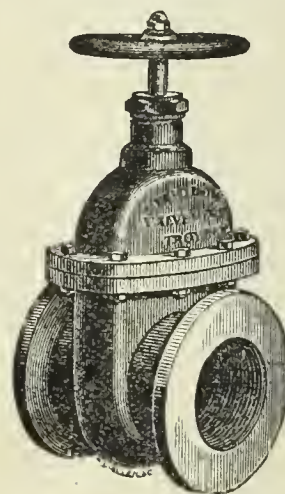

Valves.—Double and Single Gate, ½ in. to
48 in., outside and inside Screws. Indica-
tor, etc., for Gas, Water, Steam, and Oil.
Send for Circulars.

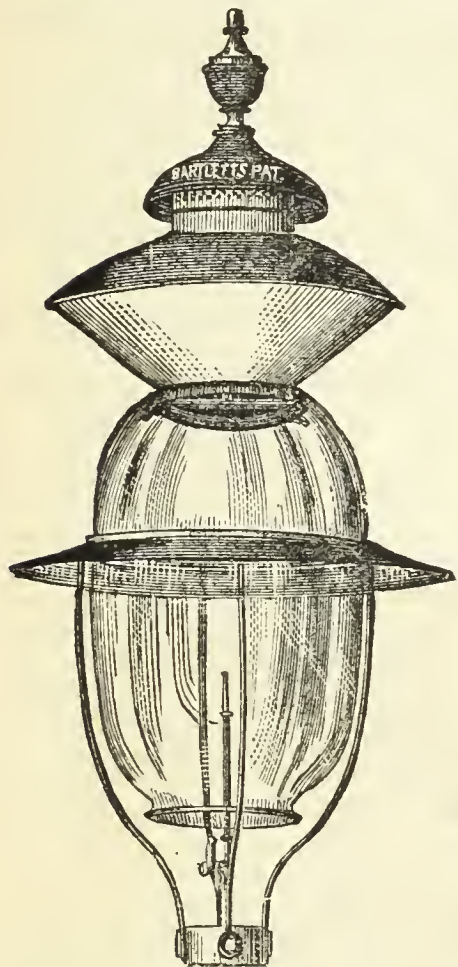

G. S. COOK, Pres. THOS. DAVENPORT (late Davenport Bros.), Sec. & Treas

BARTLETT
Street Lamp Mfg. Co.

MANUFACTURERS OF

Bartlett's Patent

GLOBE LAMPS.

FOR

Streets, Parks, Railroad Stations, Public
Buildings, Etc.

LAMP POSTS A SPECIALTY.

Office and Salesroom

No. 35 Howard Street, N. Y. City.

Gas Companies and others intending to erect lamps and posts
will do well to communicate with us.

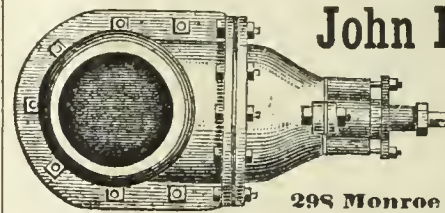

John McLean

Manufacturer of

**GAS
VALVES.**

298 Monroe Street, N. Y.

ENGLISH
"Journal of Gas Lighting."

Issued weekly. New volume commences Jan. 1, 1887. Price, \$7
per annum. Subscriptions taken by

CHARLES NETTLETON, Agent for U. S.,
No. 115 BROADWAY, N. Y. CITY.

GAS

AS A SOURCE OF

LIGHT, HEAT, AND POWER.

By C. J. R. HUMPHREYS.

A Pamphlet of twenty-nine pages, treating of the use of Gas as a
source of Light, Heat, and Power.

DESIGNED FOR DISTRIBUTION BY GAS COMPANIES AMONG THEIR CUSTOMERS AND OTHERS.

Price, 10 cents each, \$5 per 100, \$50 per 1,000.

Gas Companies can have their own imprint placed on cover without extra charge. All orders to be sent to

A. M. CALLENDER & CO.,

No. 42 Pine Street, N. Y. City.

GAS STOVES.

GAS STOVES.

GAS STOVES.

THE AMERICAN METER CO.,

MANUFACTORIES,

508 to 514 West Twenty-second St., N. Y.

Arch and Twenty-second St., Phila.

Nos. 244 & 246 North Wells Street, Chicago, Ill.

AGENCIES,

No. 177 Elm Street, Cincinnati, Ohio.

Nos. 122 & 124 Sutter Street, San Francisco Cal

No. 810 North Second Street, St. Louis, Mo.

NEW

INCANDESCENT

Gas Fires

AND

OPEN

Fire Place

Heaters.

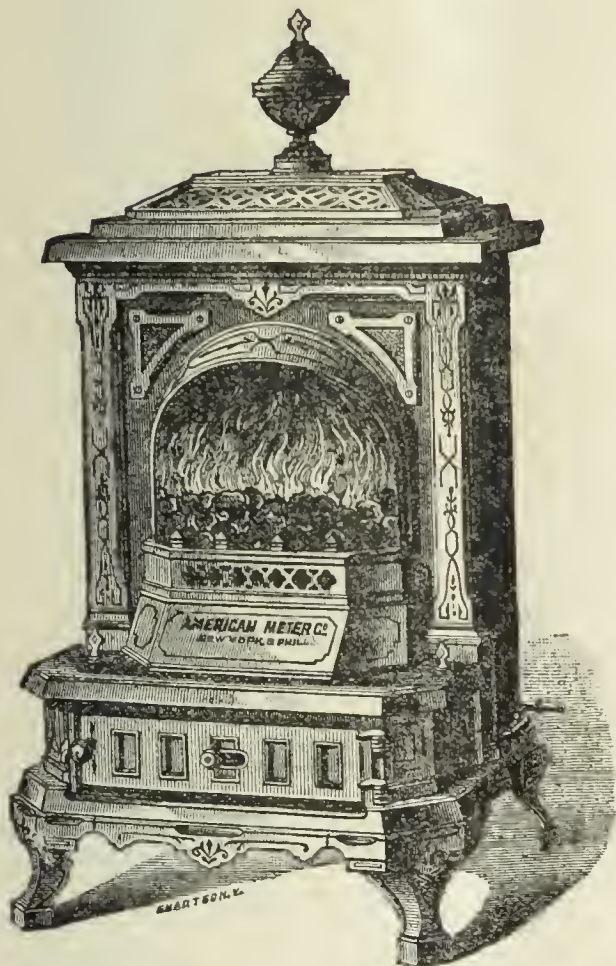

Open Fire Place Heater No. 19.
Fitted with the new Incandescent Gas Fire.

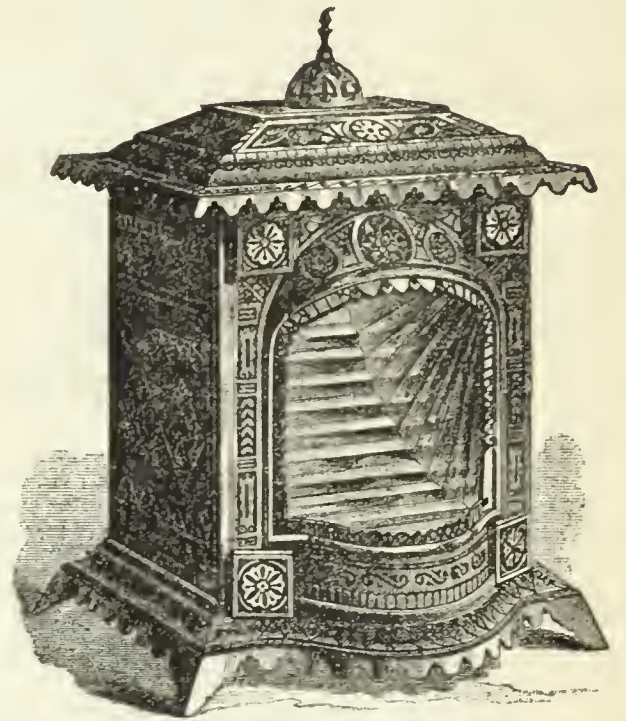

Open Fire Place Heater No. 17C.
Fitted with Illuminating Burners and Copper Reflectors.

We call attention to Special Apparatus Heated by Gas for Manufacturing Purposes.

GAS FURNACES FOR TINMEN'S USE; FURNACES FOR MELTING SOLDER AND TYPE METAL; APPARATUS FOR BENDING CARRIAGE PANELS, NOW IN SUCCESSFUL OPERATION IN CARRIAGE MANUFACTORIES; WATER HEATERS FOR KITCHEN BOILERS, BATHS, ETC., AND FOR ATTACHING TO HEATING COILS AND PIPES FOR CONSERVATORIES.

THE COMPANY MANUFACTURE

GAS STOVES FOR COOKING AND HEATING PURPOSES

In all Sizes, for Domestic, Restaurant, and Hotel Use.

These Stoves may be seen in operation at our Retail Store, No. 223 Sixth Avenue, N. Y. Call and examine.

SEND FOR CATALOGUE OF TWENTY DIFFERENT STYLES OF HEATING STOVES.

RETORTS AND FIRE BRICK.

RETORTS AND FIRE BRICK.

RETORTS AND FIRE BRICK.

J. H. CAUTIER & CO.,

CORNER OF

GREENE AND ESSEX STREETS,
JERSEY CITY, N. J.

MANUFACTURERS OF

**Clay Gas Retorts,
Gas House Tiles,
Fire Bricks, Etc. Etc.**Ground Clay, Fire Brick and
Fire Sand in Barrels,J. H. GAUTIER.
C. E. GREGORY.T. B. GAUTIER.
C. E. GAUTIER.**BROOKLYN****Clay Retort & Fire Brick Works,**

(EDWARD D. WHITE & CO.)

Manufacturers of Clay Retorts, Fire Brick,
Gas House and other Tile.VAN DYKE, ELIZABETH, RICHARDS & PARTITION STS.
Office, 88 Van Dyke St., Brooklyn, N. Y.**LAGLEDE FIRE BRICK MFG. CO.,**

MANUFACTURERS OF

Fire Brick, Gas Retorts,

AND

ST. LOUIS STANDARD SEWER PIPE.Blast Furnace and Cupola Linings, every description of Fire
Clay Material, Fire Clay Flue Linings, Chimney Tops
Dry Milled and Crude Fire Clays, etc.

OFFICE AND DEPOT

901, 903, and 905 Pine Street,

ST. LOUIS, MO.

ESTABLISHED IN 1845.

B. KREISCHER & SONS,

OFFICE FOOT OF HOUSTON ST., E.R., N.Y.

Gas Retorts,**TILES, FIRE BRICK.**

AND EVERYTHING IN THE FIRE CLAY LINE.

MANHATTAN

FIRE BRICK & ENAMELLED CLAY

RETORT WORKS.**ADAM WEBER.****CLAY GAS RETORTS**

AND RETORT SETTINGS

FIRE BRICKS, TILES, ETC.,

Office and Works, 15th Street and Avenue C., N. Y.

Works,
LOCKPORT STATION, PA.

— ESTABLISHED 1864. —

JAMES GARDNER, JR.,

Successor to WILLIAM GARDNER & SON.

Fire Clay Goods for Gas Works.

CHAS. H. SPRAGUE & SON, No. 70 KILBY STREET, BOSTON, MASS., Agents for the New England States.

Office, Rooms 19 & 20, Lewis Block,
PITTSBURGH, PA., P. O. Box 373.

OFFICE, 418 to 422 East 23d St., New York.

ESTABLISHED 1856.

WORKS, PERTH AMBOY, NEW JERSEY.

HENRY MAURER & SON,
Excelsior Fire Brick & Clay Retort Works
CLAY GAS RETORTS, BENCH SETTINGS, FIRE BRICK, TILES, ETC.**CHICAGO**
Retort & Fire Brick Works,OFFICE AND FACTORY,
Clark, Forty-Fifth, and La Salle Streets,
CHICAGO, ILL.

GEORGE C. HICKS, PRES. PAUL P. USTIN, SEC. & TREAS.

STANDARD

Clay Retorts and Settings.**BLOCKS & TILES**

Of every Shape and Size to Order.

Standard Fire Bricks.**GEROULD'S IMPROVED RETORT CEMENT.**A Cement for patching retorts, putting on mouthpieces, and
making up all bench-work joints. This Cement is mixed ready
for use. Economic and thorough in its work. Fully warranted
to stick. For recommendations and price list address**C. L. GEROULD,**
Manchester, N. H.

Western Agent, H. T. GEROULD, Mendota, Ill.

OAKHILL**GAS RETORT & FIRE BRICK**

Works.

Proprietors,

PARKER-RUSSELL MINING & MFG. CO.

City Office, 711 Pine Street,

ST. LOUIS, MO.

Our immense establishment is now employed almost entirely in
the manufacture of**MATERIALS FOR GAS COMPANIES.**We have studied and perfected three important points. Our re-
torts are made to stand changes of temperature, the strongest
heats of the furnace, and the abrasion of feeding and emptying.
Our customers are in almost every State of the Union, to all of
whom we refer.

THOS. SMITH, Prest. AUGUST LAMBLA, Vice-Prest. & Sup

BALTIMORE
RETORT & FIRE BRICK CO.

MANUFACTORY AT

LOCUST POINT, BALTIMORE, MD.

Connection with the City by Telephone.

Clay Retorts, Blocks & Tiles,
FIRE BRICK, FIRE CLAY,
AND FIRE CEMENT.**Red and Buff Ornamental Tiles and Chim-
ney Tops. Drain and Sewer Pipe (from
2 to 30 inches). Baker Oven Tiles
12 x 12 x 2 and 10 x 10 x 2.****WALDO BROS., 88 WATER ST., BOSTON, MASS**

Sole Agents the New England States

RETORTS AND FIRE BRICK.

REGENERATIVE FURNACES.

EXHAUSTERS.

EVENS & HOWARD,
916 Market St., St. Louis. Mo.
Works, Howard Station, Mo. Pacific R.R.

Fire Brick, Gas Retorts

AND

RETORT SETTINGS.

Sewer Pipe, 3 to 24 in. diameter.
Glass Pot Clay, Ground Fire Clay, in barrels and in bulk. All kinds of Fire Clay Goods.

Cincinnati Gas Retort & Fire Brick Works.

—ESTABLISHED 1872.—

CHAS. TAYLOR,

MANUFACTURER OF

Gas Retorts, Fire Brick, and Tile.

Blast Furnace Linings, Cupola Blocks, Boiler Tiles, Grate Settings, and Stove Linings. Fire Cement, Fire Clay, Fire Sand, and all other Fire Clay Goods.

Branch Works, New Cumberland, W. Va.

GENERAL OFFICE AND WORKS,

Burns St., Cincinnati, Ohio.

Stettiner

Chamotte Fabrik Actien Gesellschaft,

Formerly **DIDIER,**

(Patentees of the Dr. Schilling & Dr. Bunte Regenerative Furnace)

STETTIN, GERMANY.

The attention of all Gas Engineers is called to our Fire-Proof Material, viz.:

CLAY GAS RETORTS

(ENAMELED AND UNENAMELED),

Blocks, Tiles

AND

EXTRA FIRE BRICK,

Pronounced by the highest authorities as superior to and excelling any other similar manufacture. The component of aluminum contained in our material (up to 45 per cent.) is larger than in any other material heretofore sold in the United States; whilst the uniformity of the goods is assured by the most scrupulous analysis of the clay used.

For any further information and prices please apply to

EMIL LENZ,

2 & 4 Stone St., Room 19, N. Y. City.

PATENTS.

FRANKLIN H. HOUGH,

Solicitor of American & Foreign Patents

925 F. ST., WASHINGTON, D. C.

(NEAR U. S. PATENT OFFICE.)

Personal attention given to the preparation and prosecution of applications for Letters Patent. All business before the U. S. Patent Office attended to for moderate fees. No Agency in the United States possesses superior facilities for obtaining Patents, or for ascertaining the patentability of inventions. Copies of patents furnished for 25 cents each. Correspondence solicited.

ADAM WEBER'S
New and Improved Regenerative Furnace.

ESPECIALLY ADAPTED FOR USE IN SMALL GAS WORKS.

A Saving of at Least Forty per Cent. over Old Methods.

Cheapness of construction and absence of elaboration are the chief characteristics of this Furnace. It is also applicable in cases where it is not convenient to excavate deeply below the line of the retort house.

Correspondence respectfully solicited. Descriptive Circulars on application.

Manhattan Fire Brick & Enameled Clay Retort Works.

OFFICE, 633 EAST FIFTEENTH STREET, N. Y. CITY.

MUNICH REGENERATIVE FURNACE

System Drs. Schilling and Bunte.

Greatest Durability! Minimum of Attention!

COMPLETE DISTILLATION IN 3½ HOURS.

Ten to Thirteen Pounds of Coke to Hundredweight of Coal.

NO CLINKER. NO CARBONIC OXIDE IN THE REGENERATIVE FLUES.

Almost Automatic in Action.

The Most Successful Regenerative Furnace in Use.

BARTLETT, HAYWARD & CO.

Agents for the United States.

F. M. ROOTS.

S. C. ROOTS

D. T. ROOTS.

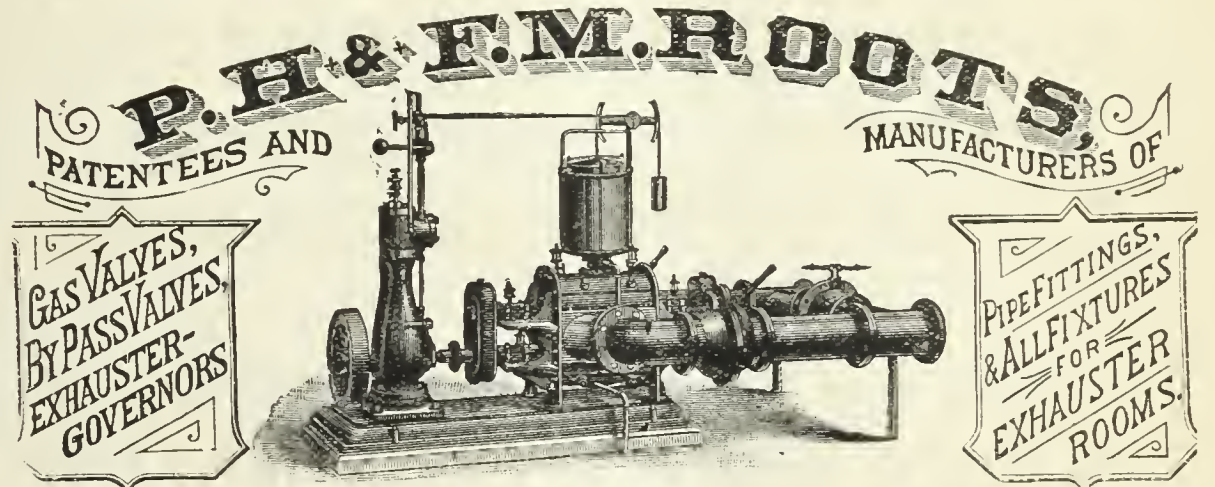

IMPROVED GAS EXHAUSTER,

WITH ENGINE ON SAME BED PLATE, OR WITHOUT.

BYE-PASSES, GAS VALVES, GOVERNORS, ELBOWS, PIPE-FITTINGS, Etc., FURNISHED TO ORDER.

P. H. & F. M. ROOTS, Patentees & Manufacturers, **CONNERSVILLE, IND.**

S. S. TOWNSEND, General Agent, 22 Cortland St.

COOKE & CO., Selling Agents, 22 Cortland St., N. Y.

✦ SEND FOR ILLUSTRATED CATALOGUE AND PRICE LIST. ✦

GAS AND WATER PIPES.

GAS AND WATER PIPES.

ENGINEERS.

SAM'L R. SHIPLEY, Pres.
HENRY B. CHEW, Treas.JAS. P. MICHELLON, Sec.
WM. SEXTON, Supt.

GLOUCESTER IRON WORKS,

GLOUCESTER CITY, N. J.

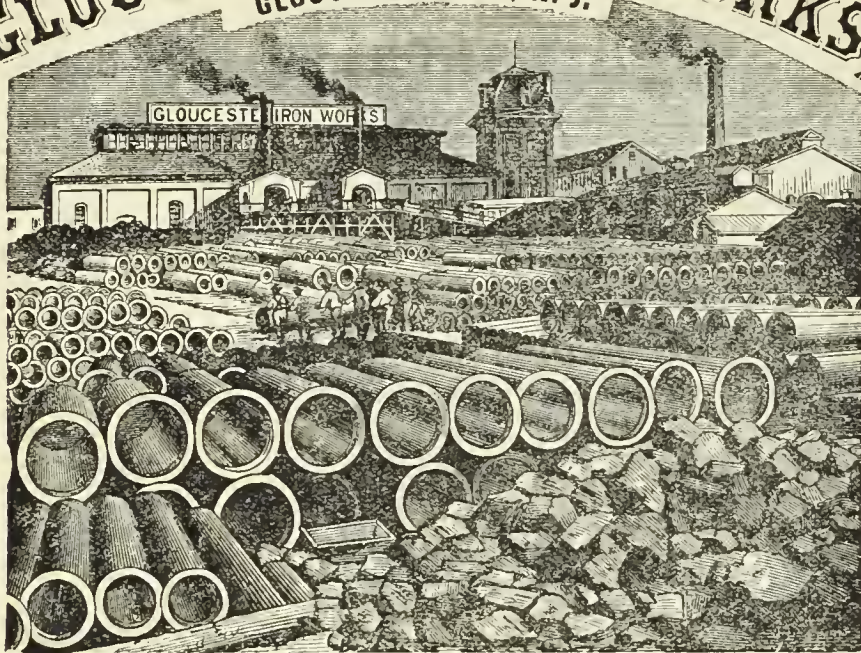

Cast Iron Gas & Water Pipes, Stop Valves, Fire Hydrants, Gasholders, &c.

Office No. 6 North Seventh Street, Philadelphia.

MATTHEW ADDY, President.

W. L. DAVIS, Selling Agent.

GEO. P. WILSHIRE, Sec. & Treas.

Cincinnati and Newport Iron and Pipe Company,

NEWPORT, KY.

Lamp Posts

AND

BENCH CASTINGS

A Specialty.

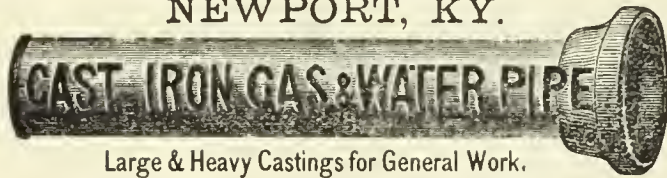

Large & Heavy Castings for General Work.

Branch

AND

SPECIAL CASTINGS

FOR GAS & WATER CO'S.

Manufacture Pipe from 2 to 48 inches. All work guaranteed first quality.

Pancoast & Rogers.

WROUGHT IRON PIPE,

VALVES AND GATES,

Cast Iron Gas & Water Pipe.

28 Platt and 15 Gold St., New York.

Parson's Steam Blower,

FOR IMPROVING BAD DRAUGHT IN BOILERS, AND FOR BURNING BREEZE OR OTHER WASTE MATERIAL.

PARSON'S TAR BURNER,

FOR UTILIZING COAL TAR AS FUEL.

PARSON'S AIR JET TUBE CLEANER,

FOR CLEANING BOILER TUBES.

These devices are all first-class. They will be sent to any responsible party for trial. No sale unless satisfactory. Manufactured by the WATERTOWN STEAM BLOWER COMPANY.

H. E. PARSON, Supt., 42 PINE ST., N. Y.

The Management of Small Gas Works.

By C. J. R. HUMPHREYS. Price, \$1.

A. M. CALLENDER & CO., 42 Pine St., N. Y.

P. D. WANNER, Chairman. A. H. MELLERT, Sec. & Treas.

MELLERT FOUNDRY & MACHINE CO., Ltd.

Reading, Pa.

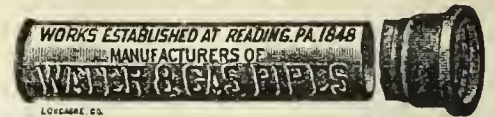

Specials—Flange Pipe, Valves and Hydrants, Lamp Posts, Retorts, etc.

General Foundry and Machine Work.

JOHN FOX, Selling Agent. 160 Broadway, N. Y.

THE OHIO PIPE COMPANY,

MANUFACTURERS OF

Cast Iron Gas & Water Pipe,

BRANCH AND SPECIAL CASTINGS.

Gas-House Bench Castings, Hydraulics, Lamp Posts, Flange Pipe and Specials, Architectural Castings, Building Columns, Joists, Cellar Grates, Sash Weights, etc.

GENERAL FOUNDERS AND MACHINISTS.

Columbus, Ohio.

M. J. DRUMMOND,



SPECIAL CASTINGS AND LAMP POSTS.

95 Liberty St., - New York.

JOS. R. THOMAS, C.E.,

May be Consulted on all Matters Relating to Gas Works and Gas Manufacture.

ADDRESS THIS OFFICE.

WM. FARMER, ENGINEER,

32 Park Place, Room 36, New York.

THE CHEMIST'S ASSISTANT; OR, KINDERGARTEN SYSTEM OF CHEMISTRY.

A system by which the elements and their valences are represented by illustrations and solid bodies.

BOX AND PAMPHLET COMPLETE, \$2.50.

WM. HENRY WHITE,

CONSULTING AND CONSTRUCTING

Gas Engineer & Contractor

Estimates, Plans, and Specifications furnished for new works or extensions of existing works.

No. 32 Pine Street, New York City.

Correspondence solicited.

WM. GARDNER,

Gas Engineer,

Lewis Block, Room 20, Pittsburgh, Pa.

Those who intend to make alterations in existing gas plants, or who contemplate the erection of new works, will find it to their interest to open correspondence with the above. Plans made and estimates furnished.

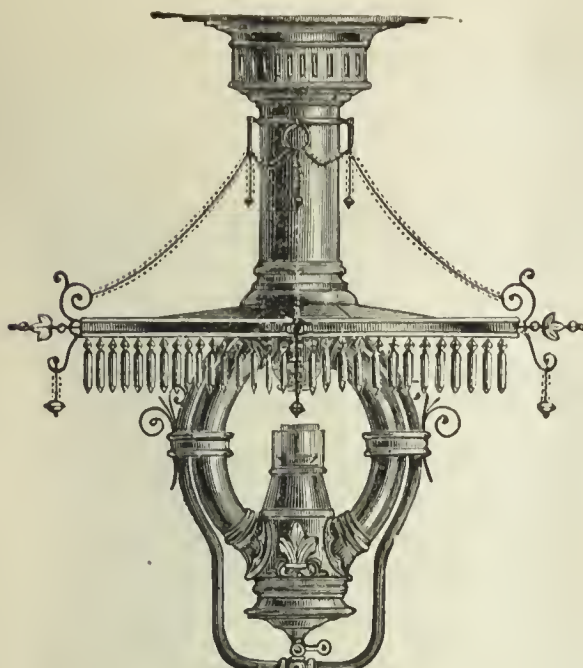

SIEMENS LAMP.

The Siemens and Lungren REGENERATIVE GAS LAMPS.

A System of Burning Gas whereby its Illuminating Power is Increased from 300 to 400 per ct. without the Expense, Trouble and Annoyance resulting from the use of Hydrocarbon Enriching Material.

The Siemens-Lungren Company received the only Silver Medal or Highest Award for Gas Burners at the "Novelties" Exhibition of the Franklin Institute, held at Phila., Oct., '85.

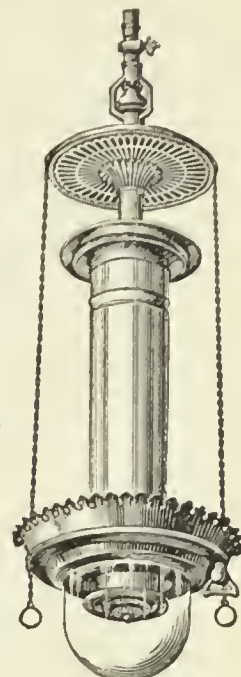

LUNGREN LAMP

THIRTEEN CANDLE POWER PER CUBIC FOOT OF GAS!

This result is obtained

SIMPLY BY THE SCIENTIFIC APPLICATION OF THE REGENERATIVE PRINCIPLE.

Consequently this largely increased illumination is always maintained without further cost and frequent attention.

THE SIEMENS-LUNCREN COMPANY,

N. E. Cor. 21st. St. and Washington Av., Phila., Pa.

THE PATENT "STANDARD" WASHER-SCRUBBER

Has been adopted by gas companies in all parts of the world. Between 300 and 400 companies, with the enormous daily output of over 300,000,000 cubic feet, are now using it. "Standard" Washer-Scrubbers have been erected for the following gas light companies since Jan. 1, 1886:

WALLASEY, ENGLAND.....	750,000 cubic feet.	RICHMOND, SURREY, ENGLAND	1,500,000 cubic feet.
NEWARK, ENGLAND.....	350,000 "	BRIDGEPORT, U. S.....	500,000 "
BUFFALO, U. S. (MUTUAL).....	500,000 "	TORONTO, CANADA.....	1,000,000 "
BERLIN, GERMANY.....	1,250,000 "	HARTFORD, U. S.....	1,000,000 "
SO. BRISBANE, AUSTRALIA.....	300,000 "	DETROIT, U. S.....	750,000 "
LEEDS, ENGLAND.....	2,000,000 "	SINGAPORE, CEYLON.....	300,000 "
FURTH, GERMANY.....	400,000 "	BRUNSWICK, GERMANY.....	300,000 "
FREIBURG, GERMANY.....	200,000 "	LILLE, FRANCE	750,000 "
NINE ELMS, LONDON.....	3,000,000 "	CADIZ, SPAIN.....	300,000 "
MELBOURNE, AUSTRALIA (2).....	3,000,000 "	READING, ENGLAND.....	2,000,000 "
GLUCKAUF COKE WORKS, GERMANY.	200,000 "	LINCOLN, U. S.....	250,000 "
BOURNEMOUTH, ENGLAND.....	1,000,000 "	ST. LOUIS, U. S. (LACLEDE).....	1,000,000 "
		BROOKLYN, U. S.....	2,000,000 "

That this apparatus is really the *standard* is indicated by the following names of important houses who represent this invention in the different countries of the world:

FRANCE & BELGIUM, Mons. J. A. Berly, 31 Rue Boinod, Paris. HOLLAND & DUTCH COLONIES, Mess. W. Hoven & Zoon, Rotterdam.

GERMANY and AUSTRO-HUNGARY, Berlin-Anhaltische-Actiengesellschaft, Berlin, Moabit, and Dessau..

RUSSIA, Mr. F. Bley, Galernaya, 44, St. Petersburg. SPAIN, Mess. Nicolas, Chamon, Foiret & Cie., 29 Rue Claude-Vellefaux, Paris.

ITALY & MALTA, Sig. E. Canziani, 26 & 28 Portici, Vittorio Emmanuele, Genoa. Sig. Fratelli Scheuer, Via Chiaja, 124, Naples.

NEW SOUTH WALES, Messrs. W. Coward & Sons, 143 Queen Victoria St., London.

NEW ZEALAND and VICTORIA, Messrs. G. D. Jennings & Co., 28 Gracechurch St., London.

Companies in the U. S. adopting this apparatus can now be assured of a market for the Ammoniacal Liquor at a remunerative price. Correspondence for purchase of "Standards" and Ammoniacal Liquor is solicited by the

SOLE AGENT AND MANUFACTURER FOR THE WESTERN HEMISPHERE,

GEO. SHEPARD PAGE, 69 WALL STREET, NEW YORK

GAS WORKS APPARATUS AND CONSTRUCTION.

GAS WORKS APPARATUS AND CONSTRUCTION.

WORKS: { MILLVILLE, N. J.
FLORENCE, "
CAMDEN, "

R. D. WOOD & CO.,

OFFICES: { 400 CHESTNUT ST.,
PHILADELPHIA.

GAST-IRON PIPE 1½ to 72 Inches in Diameter.

Water Machinery and Gas Apparatus.

HEAVY CASTINGS.

HOLDERS,

LAMP POSTS,

VALVES,

PURIFIERS,

CONDENSERS,

BENCH WORK,

FLOORS AND ROOFS,

FLANGED PIPE,

FIRE HYDRANTS,

METER CASES.

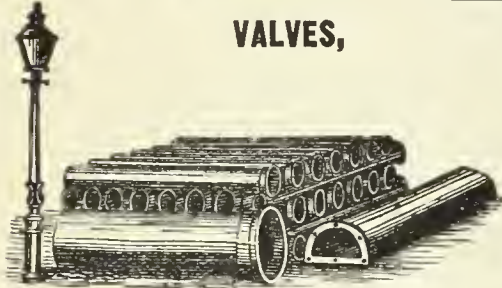

Estimates and Specifications for
NEW WORKS or **EXTENSIONS**
or **ALTERATIONS** of **OLD ONES.**

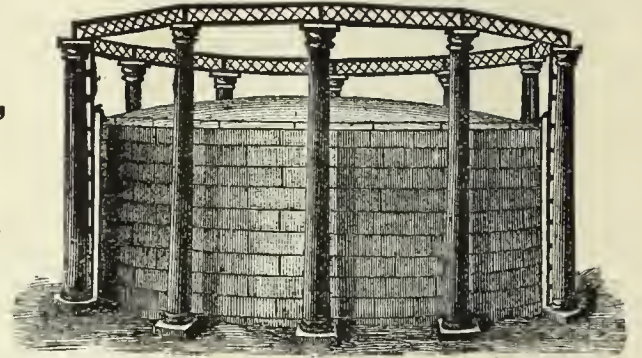

SMITH & SAYRE MFG. COMPANY,

G. G. PORTER, Prest.

245 Broadway, N. Y.

CHAS. W. ISBELL, Sec'y.

Machinery & Apparatus for Gas Works

Drawings, Plans, and Estimates Furnished for the Improvement, Extension, or Alteration of Gas Works, or for the Construction of New Works.

Mackenzie's Patent Rotary and Steam Jet Gas Exhausters, Governors, Compensators, Condensers, Washers, Scrubbers. Isbell's Patent Automatic Street Pressure Governor, Gas and Water Valves, Hydraulic Main Dip Regulator, Bench Castings, etc. Purifying Boxes and "Standard" Scrubbers. Isbell's Patent Self-Sealing Retort Doors.

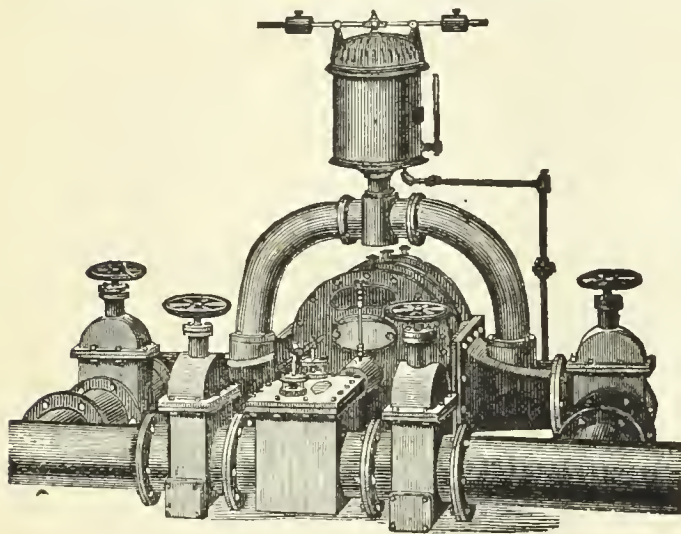

SOUTHWARK FOUNDRY AND MACHINE COMPANY,

Successors to MERRICK & SONS,

GAS APPARATUS,

Holders, Purifiers, Washers, Etc., Etc. Boiler and Tank Work. Steam Engines. Hydraulic Machinery. Bessemer Plants, Etc.

Washington Ave. and Fifth Street, Philadelphia, Pa.

MORRIS, TASKER & CO.,

Limited,

Builders of Gas Works,

PHILADELPHIA PA.

GOODWIN'S DIRECTORY

OF THE

GAS LIGHT COMPANIES OF THE UNITED STATES & CANADA

Price, \$10.00.

Orders may be sent to

A. M. CALLENDER & CO., No. 42 Pine Street, N. Y. City.

GAS WORKS APPARATUS AND CONSTRUCTION.

GAS WORKS APPARATUS AND CONSTRUCTION.

JAMES R. FLOYD,

(SUCCESSOR TO HERRING & FLOYD)

Oregon Iron Works,

531 to 543 West 20th St., N. Y.

Practical Builders of Gas Works,

MANUFACTURERS OF

**ALL KINDS OF CASTINGS
AND
APPARATUS FOR GAS-WORKS.**

BENCH CASTINGS

from benches of one to six Retorts each.

**WASHERS: MULTITUBULAR AND
AIR CONDENSERS; CONDENSERS;
SCRUBBERS**

wet and dry), and

EXHAUSTERS

for relieving Retorts from pressure.

BENDS and BRANCHES

all sizes and description.

FLOYD'S PATENT

MALLEABLE RETORT LID.

PATENT

SELF-SEALING RETORT LIDS.

FARMER'S

PATENT BYE-PASS DIP-PIPE.

SABBATON'S PATENT

FURNACE DOOR AND FRAME.

BUTLER'S

COKE SCREENING SHOVELS.

GAS GOVERNORS,

and everything connected with well regulated Gas Works at low price, and in complete order.

SELLER'S CEMENT

for stopping leaks in Retorts.

N. B.—STOP VALVES from three to thirty inches—at very low prices.

Plans, Specifications, and Estimates furnished.

KERR MURRAY MFG. CO.,

MANUFACTURERS OF

Single Lift and Telescopic

GASHOLDERS.

Built, 1884:

Altoona, Pa.	Capacity, 160,000 cubic feet.
Pittsburgh, Pa.	" 250,000 "
" "	" 220,000 "
Bellaire, Ohio.....	" 50,000 "
Youngstown, Ohio.....	" 60,000 "
Canton, "	" 60,000 "
Akron, "	" 80,000 "
Xenia, "	" 10,000 "
Adrian, Mich.....	" 65,000 "
Ypsilanti, Mich....	" 25,000 "
Muskegon, "	" 70,000 "
South Bend, Ind.....	" 70,000 "
Anderson, "	" 20,000 "
Plainfield, "	" 10,000 "
Springfield, Illinois.....	" 100,000 "
Evanston, "	" 50,000 "
Freeport, "	" 35,000 "
Elgin, "	" 60,000 "
Sheboygan Wis.....	" 20,000 "
Key West Fla.....	" 10,000 "

Plans and estimates furnished for the erection of new and the rebuilding of old works. Address

Kerr Murray Mfg. Co.,

FORT WAYNE, IND.

CONTINENTAL WORKS.



GASHOLDERS OF ANY MAGNITUDE.

T. F. ROWLAND, Proprietor,

GREENPOINT, BROOKLYN, N. Y.

ENGINEER AND MANUFACTURER OF

GAS-HOLDERS.

CONDENSERS, SCRUBBERS, VALVES,

PURIFIERS, RETORTS, and HY-

DRAULIC MAINS,

and all other articles connected with the Manufacture and Distribution of Gas. Plans and Specifications prepared and Proposals given for the necessary Plant for Lighting Cities, Towns, Mansions, and Manufactories.

H. RANSHAW, Prest. & Mangr.

WM. STACEY, Vice-Prest.

T. H. BIRCH, Asst. Mangr.

R. J. TAYLOR, Sec. & Treas.

STACEY MFG. CO.,

MANUFACTURERS OF

Single and Telescopic Gasholders,

IRON ROOFS, BRIDGES, LAMP POSTS,

Water and Oil Tanks, Coal Elevator Cars,

COKE CRUSHERS, BENCH CASTINGS,

And all kinds of Wrought and Cast Iron Work used in the erection of Coal and Oil Gas Works.

Rolling Mill Machinery and Heavy Castings a Specialty.

Foundry:

33, 35, 37 & 39 Mill Street.

Wrought Iron Works:

16, 18, 20, 22, 24 & 26 Ramsey Street:

Cincinnati, Ohio.

BARTLETT, HAYWARD & CO.,

Office, German & Calvert.

BALTIMORE, MD.

Works, Pratt & Scott.

PURIFIERS.

Boilers.

Bench Castings.

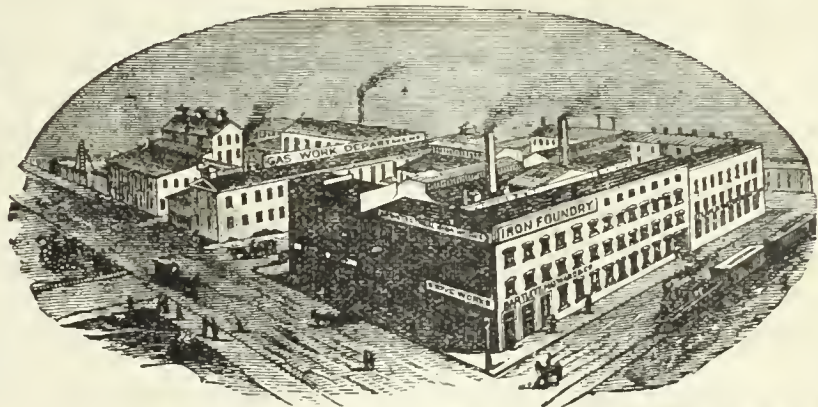

SCRUBBERS.

BOILERS.

CONDENSERS.

GASHOLDERS.

CONSTRUCTING ENGINEERS AND BUILDERS OF GAS WORKS.

1842. DEILY & FOWLER, 1887.

Laurel Iron Works.

Address, No. 39 Laurel Street, Philadelphia, Pa.

MANUFACTURERS OF

GASHOLDERS.

Single or Telescopic, with Cast or Wrought Iron Guide Frames.

Holders Built Since 1881:

Scranton, Pa. (2d)
West Point, N. Y.
Fitchburgh, Mass.
New London, Conn.
Derby, Conn.
Bridgeport, Conn.
Allegheny, Pa. (1st.)
St. Hyacinth, Can.
Norwalk, O.
Brattleboro, V.
Waltham, Mass. (2d.)
West Chester, Pa.
Baltimore, Md.

Hollidaysburg, Pa.
Galveston, Texas (2d.)
Marlboro, Mass.
Denver, Col.
Chicago, Ill. (West Side).
Pittsburgh, Pa. (S. Side).
Pawtucket, R. I.
Brookline, Mass.
Sherbrooke, Can.
Burlington, N. J. (2d.)
Bridgeton, N. J.
Bay City, Mich.
Erie, Pa.

Jackson, Mich.
Kalamazoo, Mich. (3d.)
Glen Island, N. Y.
Warren, Ohio.
Bath, N. Y.
Lynn, Mass.
New Bedford, Mass.
Waterbury, Conn.
Deseronto, Can.
Hoosic Falls, N. Y. (2d.)
Bethlenem, Pa.
Atlanta, Ga. (1st.)
Savannah, Ga.

Montgomery, Ala.
Newport, R. I.
Portland, Oregon.
Allegheny, Pa. (2d.)
Atlanta, Ga. (2d.)
N.Y. City (Central Gas Co)
Lynchburg, Va. (2d.)
Saylesville, R. I.
Rondout, N. Y.
Atlantic City, N. J.
Augusta, Ga.
Waltham, Mass. (2);
Mahanoy City, Pa.

New Castle, Pa.
Long Island City, N. Y.
Macon, Ga.
York, Pa.
Chester, Pa.
Hazleton, Pa. (2d.)
Novelties Exhib., Phila
Staten Island, N. Y.
Saugerties, N. Y.
Clinton, Mass. (Lan. M)
Chattanooga, Tenn.
Galveston, Texas. (3d.)
Omaha, Neb.

GAS COALS.

GAS ENRICHERS.

EXHAUSTERS.

JAMES D. PERKINS.

PERKINS & CO.,

F. SEAVERNS.

General Sales Agents for

The Youghioghenny River Coal Company's**OCEAN MINE YOUGHIOGHENY GAS COAL.**

The Coal from the Ocean Mine (recently operated by Messrs. W. L. Scott & Co., of Erie, Pa.,) is now used by all the leading Gas Companies in the United States from Maine to Texas, and is recognized as *the only reliable Youghioghenny Gas Coal.* (See Map on p. 87 of this Journal, Feb. 16, 1885.)

P. O. Box 3695,
New York.**PERKINS & CO., 228 and 229 N. Y. Produce Exchange.****BEAVER STREET
ENTRANCE.**

BRECKENRIDGE CANNEL, OF KENTUCKY.

This colliery was re-opened in June of the present year, and the Cannel is now being delivered to thirty of the leading Gas Companies in this country. As an enricher ONE TON of this Cannel will do the work of two TONS of any other available Cannel. It can be delivered in parcels of one car load or more to any point in the United States or Canada. (See AMERICAN GAS LIGHT JOURNAL, June 16, '86, pp. 346-7.)

P. O. Box 3695,
New York.**PERKINS & CO., 228 and 229 N. Y. Produce Exchange****BEAVER STREET
ENTRANCE.**

JAMES & WILLIAM WOOD, Gas and Cannel Coal Contractors,

No. 40 St. Enoch Sq., Glasgow. No. 2 Talbot Court, London.

Proprietors of the **BATHVILLE COLLIERIES** (which produce the celebrated **BOGHEAD CANNEL**), Shields, Shieldmuir, Drumpeller, and other Collieries. This Firm offer

STANDARD CANNELS,

Unequaled as Gas Enrichers.

Analyses, prices, and all further information furnished on application to

Agency for U. S., Room 93, Nos. 2 & 4 Stone St., N. Y. City.O. J. BENHAM,
President.C. M. HIGGINS,
Secretary.L. H. SEVERANCE,
Treasurer.**The Forest City Naptha Co.,**

REFINERS OF

Red Crown Brand**NAPTHA AND GASOLINES.**

ALSO MANUFACTURERS OF

**A Special Grade of Naptha for
Gas Companies****FOR ENRICHING COAL GAS.**

Correspondence solicited.

No. 43 Euclid Avenue, Cleveland, Ohio.

To Gas Companies.

We make to order **CAP BURNERS** to burn any amount under a stated pressure. Send for samples.Also, **SERVICE CLEANERS, DRIP PUMPS, and STREET MAIN PROVING APPARATUS.****C. A. GEFRORER,****248 N. 8th Street, Phila., Pa.**

The Wilbraham Gas Exhauster,

"BAKER SYSTEM,"

WITH ENGINE ATTACHED, ON SAME BED PLATE OR WITHOUT.

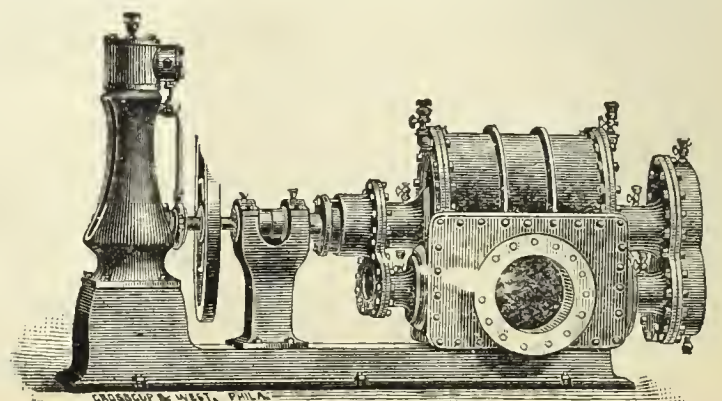
Best, Cheapest and Most Durable Exhauster known.**WILBRAHAM BROS.,****No. 2320 Frankford Avenue, Philadelphia, Pa.**

COKE CRUSHERS.

GAS COALS.

GAS COALS.

Newburgh Orrel Coal Co.,

MINERS AND SHIPPERS OF

Mountain Brook Steam and Smithing Coals,

AURORA, TYRCONNELL & PALATINE GAS COALS.

Foundry & Crushed Coke Shipped Direct from Ovens

Mines Situated at

Newburgh, Flemington & Fairmont, W.Va.

HOME OFFICE,

33 S. Gay St., Baltimore.

CHAS. MACKALL, Gen. Mangr.

CHAS. W. HAYS, Agent in New York,

Room 147, WASHINGTON BUILDING, No. 1 Broadway.

Shipping wharves at Locust Point, Baltimore.

THE DESPARD COAL COMPANY

OFFER THEIR SUPERIOR

DESPARD COAL

To Gas Light Companies and Manufacturers of Fire Clay Goods Throughout the Country.

ROUSSEL & HICKS, } AGENTS. { BANGS & HORTON, }
71 Broadway, N. Y. } { 16 Kilby St., Boston. }

Mines in Harrison Co., West Va. Wharves, Locust Point, Balt.

Company's Office, 15 German St., Baltimore, Md.

Among the consumers of Despard Coal we name: Manhattan Gas Light Co., N. Y.; Metropolitan Gas Light Co., N. Y.; Jersey City, (N. J.) Gas Light Co.; Washington (D. C.) Gas Light Co.; Portland (Maine) Gas Light Co. Reference to them is requested.

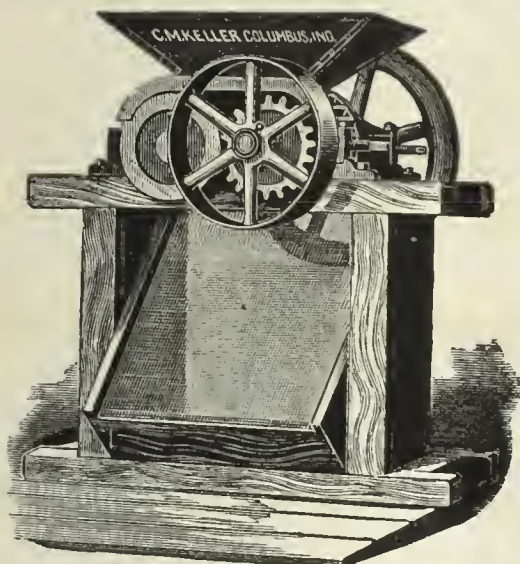

Keller's Adjustable Coke Crusher.

SIMPLE, STRONG, AND DURABLE.

C. M. Keller, Sec. & Supt. Gas Lt. & Coke Co. Columbus, Ind.

Correspondence Solicited.

GAS COMPANIES, ATTENTION!
Increase the demand for Coke by using the
Star Coke Breaker.
SIMPLE, CHEAP, DURABLE. EASILY SHARPENED
BY ANY BLACKSMITH.
B. J. ALLEN, Newark Gas Co., Newark, N.J.

King's Treatise on Coal Gas.

The most complete work on Coal Gas ever published.

Three Vols. Bound, \$30.

A. M. CALLENDER & CO., 42 Pine St., N. Y.

THE PENN GAS COAL CO.

OFFER THEIR

Coal, Carefully Screened & Prepared for Gas Purposes.

Their Property is located in the Youghiogheny Coal Basin, near Irwin and Penn Stations on the Pennsylvania Railroad, and on the Youghiogheny River.

Principal Office:

209 SOUTH THIRD STREET, PHILA., PA.

Points of Shipment:

Pennsylvania Railroad Piers; Greenwich Wharves, Delaware River; Pier No. 1 (Lower Side), South Amboy, N. J.

Chesapeake & Ohio Railway Coal Agency,

FOR THE SALE OF THE

Superior Kanawha Gas Coals, Cannelton Cannel, Also, SPLINT AND STEAM COALS,

From the Kanawha and New River Regions, on the line of the Chesapeake & Ohio R'way.

C. B. ORCUTT, Sales Agent. | OFFICE, 150 BROADWAY, N. Y.

FRANCIS H. JACKSON, Prest. EDMUND H. MCCULLOUGH, V.-Prest. CHAS. F. GODSHALL, Treas. H. C. ADAMS, Sec.

THE WESTMORELAND COAL CO.

Chartered 1854.

Mines situated on the Pennsylvania and the Baltimore and Ohio Railroads, in Westmoreland County, Penn.

POINTS OF SHIPMENT:

PHILADELPHIA, BALTIMORE, SOUTH AMBOY, N. J., WATKINS (SENECA LAKE), N. Y.

Since the commencement of operations by this Company its well-known Coal has been largely used by the Gas Companies of New England and the Middle States, and its character is established as having no superior in gas giving qualities, and in freedom from sulphur and other impurities.

Principal Office, 224 South 3d St., Phila., Pa.

A. M. SCOTT, PRESIDENT. A. DEMPSTER, C.E., SECRETARY. W. K. GILLESPIE, TREASURER.

MONONGAHELA AND PETERS CREEK GAS COAL CO.,

PRODUCERS OF

Coal Bluff Gas Coal.

MINES LOCATED ON THE MONONGAHELA DIVISION OF THE PENNSYLVANIA RR., IN THE CENTRAL PORTION OF THE PITTSBURGH COAL FIELD.

Points of Shipment—Buffalo, Cleveland, Erie, Chicago, New Orleans.

Since the introduction of Coal Bluff Gas Coal it has taken rank among the few first-class Gas Coals, and acknowledges no superior in gas-giving qualities, ease of working, quality of coke, and freedom from impurities.

General Eastern Agents, ANDREW LANGDON & CO., Buffalo, N. Y.

General Western Agents, ANDREW LANGDON & CO., Chicago, Ill.

Milwaukee Agents, F. R. BUELL & CO., - - - Milwaukee, Wis.

General Office, 43 Sixth Ave., Pittsburgh, Pa.

GAS METERS.

GAS METERS.

GAS METERS.



INTERNATIONAL--1876--EXHIBITION.

The U. S. Centennial Commission

HAVE DECREED AN AWARD TO

HARRIS, GRIFFIN & CO.,

Twelfth and Brown Streets, Philadelphia, Pa. No. 49 Dey Street, N. Y. City, and No. 75 North Clinton Street, Chicago, Ill.

FOR THE FOLLOWING REASONS:

The Exhibit consists of a Series of METERS from the Largest Size Station Meters for the use of the MANUFACTURE OF GAS, to those for the use of the ORDINARY CONSUMER. The Instruments are WELL MADE, RELIABLE as to INDICATION, and embody a number of sundry improvements which, with the general character of the Exhibit, entitle the whole to commendation.

Attest—J. L. CAMPBELL,
Secretary, pro-tem.

Signed—A. T. GOSHORN,
Director General

J. B. HAWLEY,
President

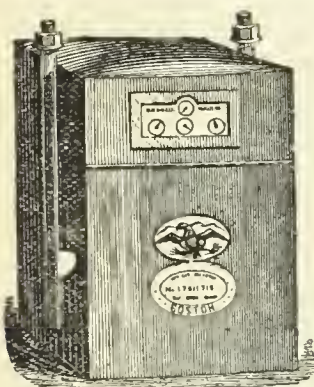

Dry Gas Meter.

With 39 years' experience and the best facilities for manufacturing, is enabled to furnish reliable work and answer orders promptly.

NATHANIEL TUFTS,

No. 153 Franklin Street, Boston, Mass.,

MANUFACTURER OF

DRY GAS METERS.

Station Meters of any Capacity.

Test and Experimental Meters, Pressure Registers, Pressure Gauges,
Pressure and Vacuum Gauges.

METER PROVERS, PHOTOMETERS, STREET LANTERNS, ETC., ETC.

Patent Cluster Lanterns for Street Illumination.

SCIENTIFIC BOOKS.

We are prepared to furnish to Gas Managers, and others interested in the topics treated of, the following books, at prices named:

KING'S TREATISE ON THE MANUFACTURE OF COAL GAS. Three vols.; \$10 per vol.	PRACTICAL TREATISE ON HEAT, by THOMAS BOX. Second edition. \$5.	THE GAS MANAGER IN THE LABORATORY, by a Practical Student. 8vo., Cloth. \$1.50.
GAS MANUFACTURE, by WILLIAM RICHARDS. 4to., with numerous Engravings and Plates, in Cloth binding. \$12.	GAS WORKS—THEIR ARRANGEMENT, CONSTRUCTION, PLANT, AND MACHINERY. \$8.	THE DOMESTIC USES OF COAL GAS, AS APPLIED TO LIGHTING, by W. SUGG. \$1.40.
THE GAS ANALYST'S MANUAL, by F. W. HARTLEY. \$2.50.	COAL; ITS HISTORY AND USE, by PROF. THORPE. \$3.50.	DISTILLATION OF COAL TAR AND AMMONIACAL LIQUOR by GEO. LUNGE. \$8.50.
TECHNICAL GAS ANALYSIS. \$2.80.	THE GAS WORKS OF LONDON, by COLBURN. 60 cents.	A TREATISE ON THE COMPARATIVE COMMERCIAL VALUES OF GAS COALS AND CANNELS, by D. A. GRAHAM 8vo., Cloth. \$8.
GAS MANAGER'S HANDBOOK, by THOS. NEWBIGGING. \$4.80.	THE GAS FITTER'S GUIDE, Showing the Principles and Practice of Lighting with Coal Gas, by JOHN ELDRIDGE. 40 cents.	GAS AS A SOURCE OF LIGHT, HEAT, AND POWER, by C. J. R. HUMPHREYS. 10 cents.
GAS CONSUMER'S GUIDE. \$1.	GAS WORKS, AND MANUFACTURING COAL GAS, HUGHES. \$2.20.	GAS COMPANIES DIRECTORY. \$10.
A GUIDE TO GAS LIGHTING. 40 cents.	THE MANAGEMENT OF SMALL GAS WORKS, by C. J. R. HUMPHREYS. \$1.	GAS VERSUS ELECTRIC LIGHT. 50 cents.
GAS MEASUREMENT AND GAS METER TESTING, by F. W. HARTLEY. \$1.60	MANUAL FOR GAS ENGINEERING STUDENTS, by D. LEE, 40 cents.	PURIFICATION OF COAL GAS, by R. P. SPICE. 8vo. \$8.
GAS CONSUMER'S HANDBOOK, by WILLIAM RICHARDS, C.E.; 18mo., Sewed. 20 cents.	HOW TO MANAGE GAS, by F. WILKINS. Paper. 20 cents.	

The above will be forwarded by express, upon receipt of price. We take especial pains in securing and forwarding any other Works that may be desired, upon receipt of order. All remittances should be made by check, draft, or post office money order.

A. M. CALLENDER & CO., No. 42 Pine Street, New York.

KING'S TREATISE ON COAL GAS.

The most complete work on Coal Gas ever published. Three vols., bound \$30

A. M. CALLENDER & CO., No. 42 Pine Street, New York.

GAS METERS.

GAS METERS.

GAS METERS.

T. C. HOPPER, Pres. G. J. MoGOURKEY, Vice-Pres. (New York). WM. N. MILSTED, Gen. Supt. & Treas. (New York). WM. H. DOWN Sec.

AMERICAN METER COMPANY,

WET AND DRY GAS METERS.

PRESSURE REGISTERS.

METER PROVERS.

STATION METERS.

PRESSURE & VACUUM REGISTERS.

PORTABLE TEST METERS.

EXHAUSTER GOVERNORS.

PRESSURE & VACUUM GAUGES.

EXPERIMENTAL METERS.

DRY CENTRE VALVES.

CRESSON GAS REGULATORS.

AMMONIA TEST METERS.

GOVERNORS FOR GAS WORKS.

MARSLAND WATER METERS.

BAR AND JET PHOTOMETERS.

Manufactories:

512 W. 22d St., N. Y.
Arch & 22d Sts., Phila.

GAS STOVES,

SUGG'S "STANDARD" ARGAND BURNERS,
SUGG'S ILLUMINATING POWER METER,
Wet Meters, with Lizar's "Invariable Measuring" Drum.

Agencies:

177 Elm Street, Cincinnati.
214 & 216 N. Wells Street, Chicago.
810 North Second Street, St. Louis.
122 & 124 Sutter St., San Francisco

HELME & McILHENNY,

(Successors to Harris & Brother. Established 1848.)

GAS METER MANUFACTURERS,

CONTINUE AS HERETOFORE AT THE OLD ESTABLISHMENT,

Nos. 1339 to 1349 Cherry Street, Philadelphia, Pa.,

To Manufacture Wet and Dry Gas Meters, Station Meters, Experimental Meters, Meter Provers, Center Seals, Pressure Registers
GOVERNORS, INDICATORS, PHOTOMETERS, & ALL OTHER KINDS OF APPARATUS FOR USE IN GAS WORKS.

From our long practical experience of the business, and from our personal supervision of all work, we can guarantee all orders to be executed promptly and in every respect satisfactorily.

WM. WALLACE GOODWIN, Pres. and Treas.

WM. H. MERRICK, V.-Pres.

S. L. JONES, Sec.

S. V. MERRICK, Supt.

THE GOODWIN GAS STOVE AND METER COMPANY,

Successors to W. W. GOODWIN & CO.

1012, 1014 and 1016 Filbert St., Phila., Pa. 142 Chambers St., New York.
76 Dearborn St., Chicago, Ill.

WALDO BROS., Agents, 88 Water St., Boston.

MANUFACTURERS OF THE "SUN DIAL" GAS STOVES, FOR COOKING AND HEATING PURPOSES.

Dry and Wet GAS METERS, Station Meters (Square, Cylindrical or in Staves) Glazed Meters, King's and Sugg's Experimental Meters, Lamp Post Meters, Etc., Etc., Meter Provers (sizes 2, 5 and 10 feet), Pressure Gauges of all kinds, Pressure Registers, Pressure and Vacuum Registers, Pressure Indicators (sizes 4 inch, 6 inch and 9 inch), King's Pressure and Vacuum Gauges, Dry and Wet Centre Seals, Dry and Wet Governors, Exhauster Governors, Photometers of all descriptions. Letheby's Sulphur and Ammonia Test Apparatus complete—also Testing and Chemical Apparatus of all kinds, and of the most perfect description, for all purposes relating to Gas.

GOODWIN'S IMPROVED LOWE'S JET PHOTOMETER.

Agents for Bray's Patent Gas Burners and Lanterns.

Special attention to repairs of Meters, and all apparatus connected with the business.
All work guaranteed first class in every particular, and orders filled promptly.

G. B. EDWARDS, Mang'r, New York.
E. H. B. TWINING, Mang'r, Chicago.
Represented by A. B. STANNARD.

D. McDONALD & CO.,

GAS METER MANUFACTURERS.

(Established 1854.)

51 Lancaster St., Albany, N. Y. 34 & 36 West Monroe St., Chicago, Ill.

STATION METERS, EXPERIMENTAL METERS, METER PROVERS, PRESSURE & VACUUM REGISTERS, PRESSURE GAUGES, ETC.

Also STAR GAS STOVES, RANGES, and HEATING STOVES.

We use only the very best materials, and employ the most skilled labor, and by our long experience (29 years) and personal supervision of every detail, we feel justified in assuring the public that our goods will give perfect satisfaction. Every Meter emanating from our establishment will bear the State Inspector's Badge, and will be fully warranted by us. Our Annual and Calendar will be sent to Gas Companies upon application.

GAS ENGINES.

GAS ENGINES.

GAS ENGINES.

THE "OTTO" GAS ENGINE.

Guaranteed to Consume 25 to 75
Per Cent. LESS GAS than ANY OTHER GAS ENGINE
DOING THE SAME WORK.

TWIN ENGINES Impulse every revolution.
THE STEADIEST RUNNING GAS ENGINE YET MADE.

ENCINES AND PUMPS COMBINED,

For Hydraulic Elevators, Town Water Supply, or Railway Service.

Special Engines for Electric Light Work.

OVER 15,000
IN USE.

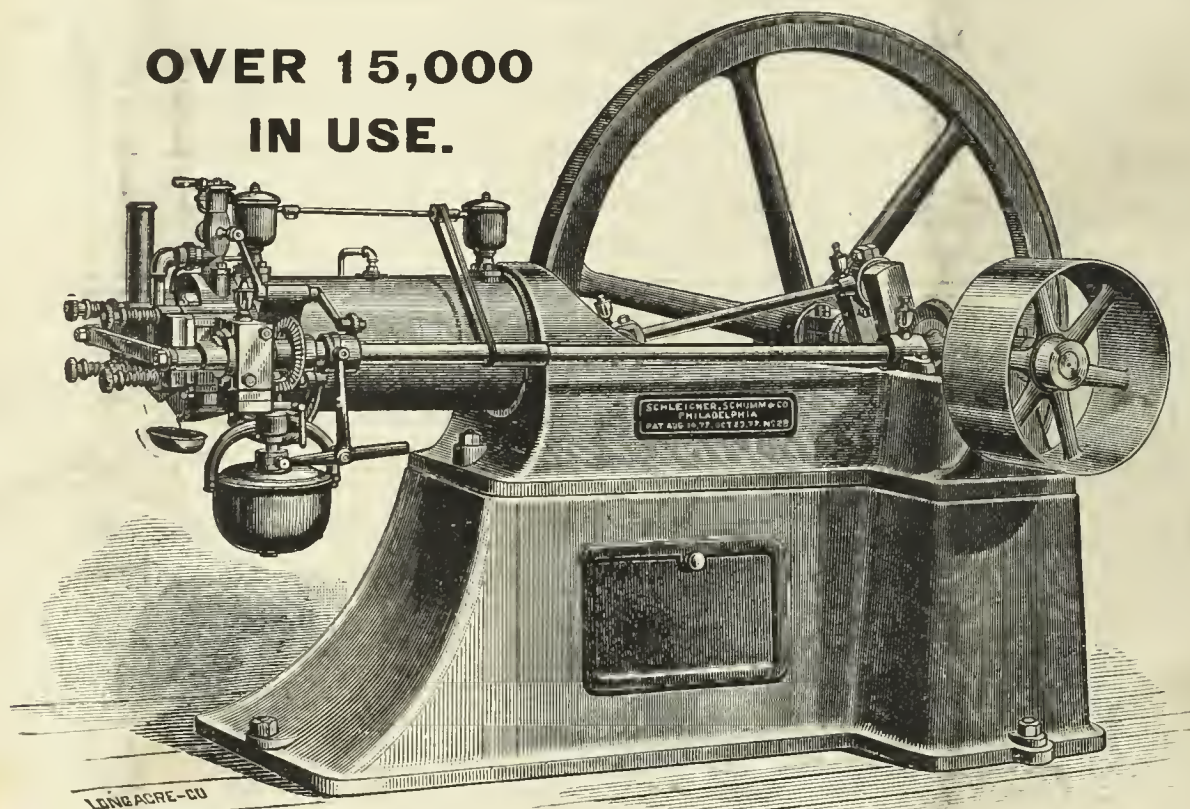

The Otto Gas Engine is now consuming, at a moderate computation, 2000 millions cubic feet of gas per year, nearly all of which is furnished during day time only.

THE ONLY HIGHEST AWARD, ONLY GOLD MEDAL,

AT ELECTRICAL EXHIBITION, PARIS, 1881.

MADE IN SIZES FROM 1 TO 25 HP. INDICATED.

FOR PARTICULARS, PRICES, ETC., APPLY TO

SCHLEICHER, SCHUMM & CO.,

Works:

Branch Office:

N E. Cor. 33d & Walnut Sts., Phila., Pa.

130 Washington Street, Chicago, Ill.

THE AMERICAN

GAS LIGHT JOURNAL

REDMAN & KENNY, N. Y.

PUBLISHING OFFICE No. 42 PINE STREET

DEVOTED TO THE INTERESTS OF ILLUMINATION, VENTILATION, WATER SUPPLY AND DISTRIBUTION, & GENERAL SCIENCE.

VOLUME XLVI.—No. 7. }
Whole No. 667.

NEW YORK, SATURDAY, APRIL 2, 1887.

{ \$3 PER ANNUM,
IN ADVANCE.

A. M. CALLENDER & CO., Proprietors. C. E. SANDERSON, Manager.
JOS. R. THOMAS, C.E., Editor. T. J. CUNNINGHAM, Asst. Editor.

ENTERED AT THE POST OFFICE AT NEW YORK, N. Y.
AS SECOND CLASS MATTER.

Published on the 2d and 16th of each month, at No. 42 Pine Street, N. Y.

Terms of Subscription, Including Postage.—For the United States and Canada, \$3 per annum. European countries, \$3.50 (15 shillings—18 francs). All payments to be made in advance. Single copies, 15 cents.

Remittances should be made either by post-office order, registered letter, or bank draft on New York, payable to the order of A. M. Callender & Co.

Correspondence.—Wishing to make this JOURNAL a gazette of intelligent discussion to those of our readers who may wish to gain or give information on the subjects to which its columns are devoted, correspondence is solicited for publication from all who make the study of those subjects a pleasure or a profession.

The American News Company, Nos. 39 and 41 Chambers street, New York, are agents for this JOURNAL. Newsdealers will send orders to them.

Collections are invariably made directly from this office, for subscriptions, advertisements, etc. We have agents to solicit the same, but they are not authorized to receipt for money.

Books.—We will forward by express, at publisher's lowest rates, any book—scientific or otherwise—to any address in the United States or Canada. No books will be sent C. O. D.

CONTENTS.

An Asterisk (*) denotes an illustrated article.

OFFICIAL NOTICE—

Western Gas Association..... 205

EDITORIALS—

The Dayton Meeting of the Ohio Association..... 206

Annual Meeting of the Guild of Gas Managers..... 206

Mr. Strecker Surprised..... 206

Third Annual Meeting of the Ohio Gas Light Association—Official Report..... 207

First Day, Morning Session—Roll Call—Report of Executive Committee—Election of Honorary Members—Released from Membership—Election of New Members—Reports of Secretary and Treasurer—President's Address—Special Committees—Responses from Letters of Invitation—Reading the Papers—Gas Commissions, by M. A. Gemuender—Discussion—Afternoon Session—Gas and Electricity; Two Interests or One? by G. W. Graeff, Jr.—Gas with Electricity, by Thos. Wood.

Special English Correspondence..... 217

Gas Companies' Accounts for the Second Half of 1886—The Competition of Oil with Gas—Sulphate of Ammonia as a Manure—Dr. Knublauch's Experiments on Limed Coal for Gas Making.

ITEMS OF INTEREST FROM VARIOUS LOCALITIES..... 218

The Breckenridge Cannel Deliveries—It was the Electric Light Company—More Contracts for Mr. Weber—Taxes with a Vengeance—The Minneapolis (Minn.) Explosion—The Manufacture of Purifier Trays—Cheaper Gas for Dallas, Texas—Cheaper Gas for Scranton, Pa.—Changes at Wilmington, N. C.—Santa Ana (Cal.) has a Gas Company—In the Hands of the Judges—Chartered at Leavenworth, Kansas—Street Lighting at Newport, R. I.—Changed Hands—Death of Mr. Sherwood—Not Unlawful to Boycott a Gas Company—To Build a Holder—The Baltimore (Md.) Gas War—Extending its Sphere—Gone To—Hartford (Conn.) Notes—He did not Mean it.

CORRESPONDENCE—

A Dissenting Opinion from Cadiz..... 220

The Market for Gas Securities..... 221

[OFFICIAL NOTICE.]

Western Gas Association.

SECRETARY'S OFFICE, QUINCY, ILL., March 25, 1887.

As previously announced in these columns, the Tenth Annual Meeting of the Western Gas Association will be held at St. Louis, Mo., on the 11th, 12th and 13th days of May. The rates at the Southern, fixed upon as the headquarters of the Association, will be \$3 and \$3.50 per day,

It is the especial desire of our President and Executive Board, as well as our members, not to mention the Secretary, that this coming meeting, which will be our decennial, shall surpass in every way any of its predecessors. It is fitting that this should be the case, for it must not be forgotten that to St. Louis belongs the honor of giving birth to the Western Gas Association, an Association ranking the second of its kind in size and importance in America. Let those of our older members who are fond of indulging in retrospect, look back, through the years that have flown, to the initial meeting of our Association, held in the office of the St. Louis Gas Light Company, on the 19th day of September, 1878. At that sparsely attended gathering were present the following executive officials of gas companies: J. O. King, who may justly be entitled the Father of the Western Gas Association; Lee A. Hall, Wm. Wallace, Wm. Dunbar, Geo. B. Burns, Ed. J. King, C. A. Lockwood, J. W. Butman, L. C. Jennings, T. G. Lansden, Chas. Erskine, Z. E. Powell, John Atkinson, J. C. Zabriskie, the irrepressible Moran from the wilds of Joliet, and the writer—just sixteen in all— and a hard pull it was to get even that number together. We didn't set the world on fire at that particular meeting, if I remember rightly, but nevertheless from that little nucleus of an organization has sprung the Western Giant, which proposes to celebrate its ten years of vigorous growth and proud manhood in right royal style during the fast approaching merry month of May. Let us all unite, from North, South, East and West, in rising to the importance of the occasion and make our Tenth Annual a "boomer."

In the admirable address of ex-President Wood to the members of the American Gas Light Association, at the Philadelphia meeting, appear some remarks so pointed and forceful, and, if followed out, so conducive to the best interests of our own Association, that they will well bear careful perusal. The portion of the address to which I wish to call your particular attention will be found on page 264, issue of the AM. GAS LIGHT JOURNAL bearing date of Nov. 2, 1886.

I wish to call the particular attention of our members to the clause in Mr. Wood's address which relates to the appointment, by the Executive Committee, of a certain number whose duty it shall be to prepare and present essays for our consideration. I may be departing from my proper routine of duty in urging this matter at the present time; but to me it seems of such paramount and growing importance that I trust I may be excused for dwelling upon the point. No one, unless he has had some experience in this field, can have any clear idea of the labor involved, under our present method, of securing say eight or ten papers for presentation at one of our annual meetings. It seems at times impossible to obtain even that number; while for a two days' business session we should have at least a dozen essays. So far, although I admit that it is early in the day for complete returns, in response to upward of ninety requests I have received but two favorable replies. If anyone has doubts as to the successful working of the plan proposed by ex-President Wood, let him look at the magnificent array of papers announced by Secretary Butterworth in the JOURNAL of March 2d,

to be read before the Ohio Gas Light Association. It seems to me that such proof as this should convince the most skeptical.

From inquiries already made it is evident that our membership will receive material accessions at our St. Louis meeting. Blank forms of application will be mailed to those who desire to join our Association, if they will give notice of their intention to the undersigned.

A. W. LITTLETON, Secretary.

THE DAYTON MEETING OF THE OHIO ASSOCIATION.

When those who primarily urged the formation of an association of gas engineers for the State of Ohio, and broached the subject to those with whom they came in contact in an inquiring sort of way, some were inclined to doubt whether a fair measure of success would attend the project. Knowing full well that the seed must be planted ere the crop can be reaped, the sowers proceeded with their task, and the result is a broad field well covered with standing grain. Indeed, this lusty growth is little short of surprising, and furnishes us with abundant proof that the "Ohio idea," no matter what direction it takes, can be depended on not to fall by the wayside and be trodden under foot. However, the Ohio Association has steadily prospered and progressed, and the Dayton meeting of last March shows the important part that the Society is likely to play in future in the history of the gas business of this country. Matters discussed at its gatherings are handled from a thoroughly independent standpoint. And those who are opposed to a certain line of action, even if that divergence would appear to place them in direct antagonism to others of their fellows, have no hesitancy in placing themselves squarely on the record.

The Beckel House parlor (selected as the assembly room) on the afternoon of March 16 looked as if its capacity were to be thoroughly tested; and subsequent developments proved that to be the case. In passing, it may be said that the selected spot gave every satisfaction in respect to convenience and facility for enabling everyone to hear what was said and read. As in the current issue of the JOURNAL we give the usual preliminary report of routine business, we need only hastily refer to the excellent attendance and the large accession made to the membership list, which last reminds us that the names of four "tried men, and true," were added to the roster of honorary membership.

Coming now to the President's address, its contents were such as we might look for from the character of the speaker—sharp and to the point; although we did hope that President McMillin would have elaborated more on the matter of electric light. Nevertheless, perhaps the expectation could hardly be justified, for, let an engineer be ever so progressive, prudence must always be considered as the best possible aid to true progress, and off-handed assertions often lead to unpleasant predicaments. While the address is well punctuated with salient points, two of its features strike us as exceptionally worthy of comment. In the first place, we are surprised that the managers of the gas companies of Ohio should have been so apathetic in the matter of the movement for a State Gas Commission. That only 50 per cent. of the total number found it worth while to reply at all to the inquiries of Secretary Butterworth seems strange, and especially so when it is seen that of those replying 75 per cent. unconditionally favored the plan outlined by General Hickenlooper. Perhaps Mr. Gemuender's paper furnishes a clue to the silence of the non-committal 50 per cent., for that gentleman makes out a pretty bad case regarding the status of Ohio's legislators—both State and local. If one is better off at the hands of local boards than when in the custody of the representatives of the State-at-large, what can be expected from either? Coming to Mr. McMillin's other reference to State protection of gas interests, we find him, as usual, open to conviction from testimony presented. To make this plain we introduce here the following paragraph of his annual address: "I have read the annual report of the Massachusetts Gas Commission for 1886, with interest and profit; and while I agree with my worthy predecessor [Gen. Hickenlooper] that in return for a submission of our business to agents of the public the gas companies ought to have direct and positive protection against raiders and blackmailers, yet I do further believe that a State Commission, such as Massachusetts now has, does, in a measure, protect companies against this class of despoilers." It is reassuring to see that the foremost men of the fraternity are watching the operation of this plan with keen eyes; and we repeat what we have consistently contended for. The fraternity not only must guard itself against those who would seek to divide its possessions, but it must also be prepared to resist the insidious encroachments of others who aim at centralization of the business, whether by purchase or otherwise—unless, indeed, the present owners at some time in the future decide to appease their appetites by taking a slice from the loaf which they are about to hand over to the new comers.

Coming to the papers that were read at the Dayton assemblage, no one can find fault with their contents or their diversity. Mr. Wood, of Sandusky, in the discussion that followed his paper on "Gas with Electricity," gave the

most substantial reasons for his decided views in the premises; and it goes without saying that if his Sandusky experience could be repeated in like manner elsewhere (or, rather, everywhere), there would be no further need for keeping the matter of combined gas and electric supply in the category of moot points. The same assertion will apply to Mr. Christian's paper on the "Relative Cost of Coal and Water Gas." In fact the latter gentleman's experience is directly in conflict with that reported from the majority of localities. The papers presented are valuable and important, which goes to prove that the youngest of the Associations is plentifully supplied with those who have the courage of their convictions, and the bravery to express them.

Of course, President McMillin made an able presiding officer, and the business of the sessions was despatched with vigor and promptitude, while characterized by thorough attention to detail. Only one cause exists for regret over the Dayton meeting, which is that the President's offer of prizes for competitive papers, on the subject of high heats *versus* naphthaline crystals, failed to be taken advantage of—the requisite number of papers stipulated not having been presented.

In the matter of the banquet everything was as it should be, and reflected credit on those who arranged for it. By-the-way, it may be mentioned that the proprietor of the Beckel House (Mr. Horace Fox), taking advantage of the most approved methods for lighting his hotel, has adopted the Lungren burner. Six 16-foot Lungrens illuminated the dining-room, and Mr. Fox asserted that these had replaced 6 ordinary chandeliers, each formerly fitted with six 5-foot burners. The illumination of the place was little short of superb. The visit to the Dayton gas works, on the afternoon of the second day, ended the third annual session, and the members may well feel proud of its record.

ANNUAL MEETING OF THE GUILD OF GAS MANAGERS.

The Sixth Annual Meeting of the Guild was held in the Society's rooms, in the Mason Building, Kilby street, Boston, Mass., on Saturday, March 12th. The attendance of members was very complete; and among those present as guests, by special invitation of the Society, were the Hon. A. M. Norton, Nashua, N. H.; Messrs. Wm. H. Down, New York city; Fred. Davis, Waltham, Mass.; and Jno. Cunningham and C. H. Sprague, Boston, Mass. The annual reports of the retiring officers disclosed the fact that satisfactory progress had been made by the Society during the year. The election for officers to serve during 1887-8 resulted in the following choices:

President—Robert B. Taber, New Bedford, Mass.

Vice-President—C. F. Prichard, Lynn, Mass.

Treasurer—Jno. Andrew, Chelsea, Mass.

Secretary—E. G. Pratt, North Attleboro, Mass.

When routine business had been finished the gentlemen undertook to discuss one of "John Andrew's spreads," and were eminently successful in the attempt. The after-dinner speeches were apt and happy, and all present contributed something toward the fund of wit and reason. The Society starts upon its new year with every prospect of continued vigor and success.

MR. STRECKER SURPRISED.

It has been somewhat of an open secret of late that Mr. Alexander Strecker, who has been connected with what is now the Metropolitan branch of the Consolidated Gas Company for over 15 years—Mr. Strecker succeeded the late Mr. Ignatz Herzog, in the position of Engineer to the Metropolitan Company, on July first, 1883—had resigned to take charge of the Citizens Gas Light Company, of Newark, N. J. The date of his departure having been fixed for first instant, the officers and employees of the Metropolitan branch determined to "surprise" him, and this is how they did it. On the afternoon of March 29th the retiring Superintendent was invited to visit the purifying room, where, rather to his astonishment, he observed that Mr. Oscar Zollikoffer, and the latter's son, Mr. Oscar F. Zollikoffer, together with the under-officers and workmen of the Metropolitan station, were waiting to receive him. Ere he had recovered from his surprise Mr. Zollikoffer, Sr., mounted one of the boxes, and, precluding the action with a few well chosen words, presented Mr. Strecker with a handsome chronometer, chain and charm, which were elegant specimens of Tiffany's best art. The watch bore the inscription, "Presented by officers and employees of the Consolidated Gas Company, of New York (Metropolitan branch), to Alexander Strecker, as a parting token of appreciation and esteem. March 31, 1887." The recipient was completely taken aback, but what his reply lacked in words was fully made up by the emotion displayed. As evidence of the esteem in which he was held, we extract the following from Mr. Zollikoffer's presentation words: "You, as well as myself, are sorry to lose him, for he knew how to be just and fair to everyone—to his employers and to his employees; and understood the means with which to win the good-will of all around him!"

[OFFICIAL REPORT.]

Third Annual Meeting of the Ohio Gas Light Association.

HELD AT THE BECKEL HOUSE, DAYTON, OHIO, MARCH 16 AND 17, 1887.

FIRST DAY—MORNING SESSION.—WEDNESDAY, MARCH 16.

President McMillin called the members to order, Secretary Butterworth occupying the recorder's desk.

ROLL CALL.

The following members responded to their names :

Active Members.

- | | |
|----------------------------------|------------------------------------|
| Allison, M. C., Xenia. | McMillin, E., Columbus. |
| Bate, Joseph, Muncie, Ind. | Padan, H., Portsmouth. |
| Bates, T. A., Circleville. | Perry, A. T., Cleveland. |
| Bushnell, A. S., Springfield. | Phillips, J. H., Cincinnati. |
| Butterworth, Irvin, Columbus. | Prichard, W. W., Ironton. |
| Canby, R. H., Bellefontaine. | Printz, E., Zanesville. |
| Converse, C. M., Delaware. | Ranshaw, H., Cincinnati. |
| Coverdale, R. T., Cincinnati. | Raynolds, J. A., Canton. |
| Cressler, A. D., Ft. Wayne, Ind. | Roots, D. T., Connersville, Ind. |
| Dell, J., St. Louis, Mo. | Ross, W. A., Kenton. |
| Dickey, R. R., Dayton. | Salter, J., Covington, Ky. |
| Dittmar, R. A., Troy. | Salter, R., Covington, Ky. |
| Fabing, F., Fremont. | Sisson, F. N., Albany, N. Y. |
| Gemuender, M. A., Columbus. | Smallwood, J. B., Baltimore, Md. |
| Gibson, W. H., Lima. | Spinning, D. C., Dayton. |
| Graeff, G. W., Jr., Phila., Pa. | Stacey, W., Cincinnati. |
| Gwynne, J., Fostoria. | Taylor, G. H., Warren. |
| Hamlin, E. W., Wilmington. | Thompson, H. C., Cincinnati. |
| Harris, J. A., Phila., Pa. | Walker, J. H., Jr., St. Louis, Mo. |
| Huntington, P. W., Columbus. | Welch, C. H., Athens. |
| Kinsman, N., Springfield. | Wilkiemeyer, H., Lancaster. |
| Light, J., Dayton. | Wood, P. J., Wilmington. |
| McCann, J., Portsmouth. | Wood, T., Sandusky. |
| McDonald, W., Albany, N. Y. | |

REPORT OF EXECUTIVE COMMITTEE.

The Executive Committee's report was received and read. It stated that an application had been made by Mr. G. W. Graeff, Jr., of Phila., Pa., for permission to report the proceedings. The committee recommended that the application be referred to a special committee with instructions to report upon the matter at the next annual meeting. The Executive Committee recommended that Messrs. Eugene Vanderpool, of Newark, N. J., W. A. Stedman, of Newport, R. I., Jno. P. Harbison, of Hartford, Conn., and Geo. G. Ramsdell, of Vincennes, Ind., be elected Honorary Members of the Association. Also, that the applications for release of membership from Messrs. Geo. Turner, Phila., Pa., and Wm. Enfield, Dallas, Texas, be granted.

The President explained that the Association, at its first annual meeting, had made the AMERICAN GAS LIGHT JOURNAL its official organ, and that such action would have to be rescinded before a different course could prevail. Mr. Gemuender asked if a contract had been made with the JOURNAL, and the President replied, "That is what it really amounts to." Mr. Gemuender moved that the report of the Executive Committee, in regard to the application, be adopted. Agreed to. The President appointed Messrs. Eugene Printz (chairman), Jos. Bate and C. H. Welch as the special committee.

ELECTION OF HONORARY MEMBERS.

The President asked the pleasure of the members in regard to the committee's recommendations to Honorary Membership. On motion of Mr. Dickey, the Secretary was instructed to cast the affirmative ballot of the Association for the gentlemen above named. Secretary Butterworth subsequently reported that he had carried out the instructions, and the President thereupon declared that the nominees had been unanimously elected to Honorary Membership.

The Secretary's telegrams of notification to the gentlemen thus elected were duly responded to by them.

RELEASED FROM MEMBERSHIP.

The President, alluding to final recommendation of Executive Committee, explained that Messrs. Turner and Enfield were *ipso jure* released from membership.

COMMITTEE ON APPLICATIONS FOR MEMBERSHIP.

The President appointed Messrs. R. A. Dittmar, Fred. Fabing and Jos. Gwynne a committee on applications for membership.

ELECTION OF NEW MEMBERS.

The committee subsequently reported in favor of the election of the following applicants:

- | | |
|--------------------------------|-----------------------------------|
| Alexander, J. W., Painesville. | Bierce, F., Memphis, Tenn. |
| Barkdull, L. C., Sidney. | Clark, D. M., Elyria. |
| Cradit, S. B., Ripley. | Christian, G. H., Jr., Norwalk. |
| Carroll, A. J., Steubenville. | Critchlow, J. M., Pittsburgh, Pa. |
| Devor, J., Greenville. | Denniston, W. H., Pittsburgh, Pa. |
| Evers, M. B., Jr., Van Wert. | Hurlburt, H. L., Oberlin. |
| Jones, T. C., Delaware. | Lindsley, E., Cleveland. |
| Light, G., Dayton. | McCook, G. W., Steubenville. |
| Murphy, J. M., Chicago, Ills. | McCall, H., Tiffin. |
| Rempel, F. F., Logan. | Smart, G. M., Dayton. |
| Witham, S., Gallipolis. | |

The applicants were thereupon elected to active membership.

REPORTS OF SECRETARY AND TREASURER.

The annual reports of Secretary Butterworth and Treasurer Raynolds were read and received. The Secretary reported that the roll included the names of 2 honorary and 79 active members. Two had withdrawn during the year; and the mortuary record revealed the deaths of four members since the date of organization.

Treasurer Raynold's report showed that the Association had a balance to credit of \$406.24. Both reports were dated March 15, 1887; and the financial document was attested and vouched for by Mr. Wood, of the Finance Committee.

PRESIDENT'S ADDRESS.

President McMillin now read his inaugural message. It is as follows—

To the Members of the Ohio Gas Light Association:—After a year of increased prosperity we are again assembled to hear and discuss questions of economic interest pertaining to our business. That all have been profited by the discussions and consultations had at our two previous annual meetings there can be no reasonable doubt. If this meeting shall be equally productive of good the fact will be gratifying to us all.

The great improvement in the general trade of the manufacturing and commercial interests of the country has brought additional business to most of the companies represented in this Association. This increase of business brought with it a demand on the part of the consumers, generally, for a reduction in price. Twenty years ago, when gas was \$4 per thousand, the consumer thought he would be happy if he could only get his gas for \$3.50, and he had but little thought of ever seeing gas below the latter figure.

Notwithstanding the fact that gas companies are considered illiberal and arbitrary, they are still able to show a greater and more rapid reduction in the price of their product than that of any other branch of manufacturing of which I have any knowledge.

Probably, at the present time in this State, the percentage of companies selling gas at a price above \$2 does not exceed that of those selling at above \$4 twenty years ago. Probably twenty times as much gas is now sold below \$2 as is sold at and above that figure. In fact I believe I would be safe in saying that three-fourths of the total product of the works of the State is now sold below \$1.50—more than half of it at and below the low price of \$1.25 per thousand.

Still the demand for further reduction is heard in the cities where it is sold the cheapest; and, strange to say, the companies, or many of them, are almost persuaded to make further concessions.

Gas works are owned in this country almost exclusively by individuals or private corporations organized for profit. Water works are generally owned by the municipal authorities. Have these public institutions dealt as liberally with their patrons as have the gas companies?

While gas companies go on reducing the price from year to year, improving the illuminating power, increasing the purity of the gas, and furnishing the consumer with better appliances for its consumption, water works owned by the public have practically been at a standstill. Let us continue to reduce our prices and continue to improve the quality of our gas, so long as, while so doing, we can reap a fair return upon our investment.

I am inclined to think that increase of quality and reduction in price may travel further hand in hand, with a continued fair profit, than most gas men suspect; but, on the other hand, if anyone supposes that he can reduce the number of complaints, the fault findings, and the false accusations, by either reducing the price or improving the quality of his gas, he will have his mind disabused of that erroneous idea after he has made the experiment.

Let us all endeavor to do our duty, both to the public and the stockholders that we represent, regardless of what shall follow.

During the past year wonderfully rapid strides have been made by our competitor—the electric light. To this fact we should not shut our eyes. Millions of dollars are being invested in plants for manufacturing apparatus, and millions more in plants for generating lighting currents. That much of this will be a "permanent investment" there can be but little doubt. We see a few instances of it in our own State. The incandescent light does not appear to be able to compete with either the arc, gas, or coal oil lighting, at prices that can maintain the value of the capital invested. But even in this

direction much improvement is reported to have been made. There is a firm now organized and doing business in Pittsburgh, Pa., with a capital of \$5,000,000, who believe they have solved the problem of cheap incandescent lighting. With their appliances they undertake to say that, under certain conditions, where other systems would have to expend \$1,000,000 in plant to do certain work, they would do the same work more satisfactorily with an expenditure for plant not to exceed \$100,000. If it be a fact that the heretofore necessary outlay for a large plant may be divided by ten, then they are indeed getting down to a coal gas basis. This mammoth company, however, do not propose to fight gas companies, but to satisfy them of the truthfulness of their claim, and of the further fact that the same company can convert the illuminating gas plants into fuel gas plants, with profit to gas companies. To most of you these claims may sound like much of the twaddle that you have been hearing for some years, and you may be right; but bear in mind that to go down from \$1.25 to 50 cents per thousand cubic feet would be a much less improvement, with our present knowledge of the business, than it was to go from \$4 down to \$1.25 per thousand. Reject no proposed improvement without careful investigation. Even a quack may succeed, by accident, in combining some stolen ideas and bring forth an invention of utility and merit.

The mammoth falsehoods that have been sown broadcast during the last few years respecting the merits of water gas have so prejudiced the most of us that we find it difficult to do justice to almost any system that is at all tainted with that production. This ought not to be; the water gas systems have their merits, and in many localities can doubtless be combined with coal gas to the advantage and profit of the gas company. The "raiders" seem to be chiefly in the water gas gang; but *all* raiders are not there—neither are all water gas men raiders—and I sincerely trust that the members of the Ohio Association, in discussing these questions, will not so far forget themselves as to abuse gentlemen—not for their personal shortcomings, but because they may belong to a class of engineers for whom we may not have the most profound respect. All the Gas Associations of this country accept water gas men into fellowship, and our own Association is no exception. As individual members they are entitled to all the courtesies, and are eligible to all the honors to which a coal gas man may aspire.

The union of the electric and gas lighting interests is a question that is exciting much interest at the present time; but as we are to have papers on this subject I will not discuss the question in this connection further than to say that I do not oppose the bans.

In the able address* of our honored ex-President, General Hickenlooper, a plan was outlined for a proposed State Gas Commission. The plan was heartily indorsed by the members in attendance, and a committee was appointed to submit the question of the feasibility and desirability of working for the creation of such a commission. Pamphlets were issued, giving the address of the President in full, and two copies of this pamphlet, together with a circular in which a number of questions were asked, and with blank space for answers, were forwarded to every company in the State, with a request to respond, as soon as convenient, to our Secretary. A second appeal had to be made before many would respond. In some instances, third and fourth appeals were made without bringing forth a reply.

Of all the replies received, 72 per cent. unconditionally favored the plan; 20 per cent. favored the plan, with conditions; one per cent. favored another plan for a like purpose; and 7 per cent. opposed commissions in any form. Now, that would appear to be a pretty hearty indorsement of State Commissions; but you have not heard it all. Only 42 companies out of nearly 100 cared even enough about the subject to respond to our inquiries. Think of it! Less than one-half!!

If it would not be considered an impropriety, I would venture a guess that the companies failing to respond are in greater need of some such regulation than those who favored it; and further, that they are more given to growling about the condition of the present statutes governing gas companies than are other members of the gas fraternity. I doubt if there is a guilty man within the sound of my voice. Men who will not say "yes" or "no" to the questions that were asked in our circular are not much given to attending conventions; but if such an one be here, his presence indicates an honest effort on his part to reform.

Of course, with the partial response received, no effort was made to have a commission established. That a gas commission would bring about a more satisfactory condition of affairs I verily believe.

I have read the annual report of the Massachusetts Gas Commission, for 1886, with interest and profit; and while I agree with my worthy predecessor that in return for a submission of our business to agents of the public the gas companies ought to have direct and positive protection against raiders and blackmailers, yet I do further believe that a State Commission, such as Massachusetts now has, does, in a measure, protect companies against this class of despoilers.

When such a commission shows to the public that a gas company is man-

aging its business honestly, that its meters do register gas correctly, and that the company does not make more than a fair profit on its investment, then the public will be slow to invite another company to tear up its streets, and divide the business, thereby increasing the cost of manufacture, and at least deferring the time when a permanent reduction can be made in the price of gas. That such is the result of competing companies the Massachusetts Commission plainly tells the public. I repeat: *Knowledge from such a source* affords partial protection, at least.

No startling improvements in the modes of manufacture have been made during the past year, but rather a general and gradual advance has occurred all along the line, and especially in the adoption of regenerator furnaces. They are rapidly becoming the rule, instead of the exception. Builders who now construct the ordinary shallow, direct firing, retort furnace will hardly be regarded as keeping pace with improved modes.

As a result of better furnaces the yield of gas per unit of coal is being increased. There are probably as many gas works in the country to-day that reach a maximum of 5.25 feet per pound of coal as there were that reached 4.75 feet ten years ago. There is still vast room for improvement. When we treat our coal properly we will, I believe, receive 6 feet per pound, and possibly much more.

Coal with the largest per cent. of hydrogen makes the largest yield of gas. The coking coals in general use in this country contain hydrogen enough to carry nearly double the quantity of carbon that we now volatilize, and, could we make it do so, we would largely increase the quantity of light per unit of coal.

The high heats now in general use in retort houses are obtained with the expenditure of a much smaller per cent. of the coke made than were the former low heats secured; but the high heats have some disadvantages—such as choked stand-pipes, pitched mains, and naphthaline crystals about the works. The latter probably gives the most trouble.

It is to be hoped that someone may throw some light upon the subject of the prevention of this annoyance at this meeting. I shall be disappointed if the question is not thoroughly ventilated.

In purification but little, if any, advance has been made—especially in this country; but since oxide of iron has come into general use the cost of purification per 1,000 cubic feet has really become so insignificant that the subject does not now receive the attention given it a few years ago. In England what is known as the Claus' process of purification in closed vessels has made some progress. A careful study of this system will be found both interesting and instructive. Before leaving this subject I will sum it up by quoting one sentence from the able address* of President Eugene Vanderpool, at the Cincinnati meeting of the American Gas Light Association. He says: "As compared with a few years ago, we show a gain of from two to three times the yield per retort; from two to three times the product per man; an economy of one-half to two-thirds in fuel for the carbonization of coal; an increased yield from the coal carbonized of ten to twenty per cent.; a decreased wear and tear account, and an improved candle power. We use new and very efficient apparatus for removing tar; ingeniously designed scrubbers for extracting the ammonia; improved methods of mixing and using lime; and efficient and more economical ways of purification by oxide of iron." Every assertion of which is, to those who have properly kept pace with the times, a well-known fact.

Natural gas continues to grow in interest, and especially so in our own State. Just where it may or may not be found no man knows. That secret is given up only as the drill pierces the deeply hidden recesses of the earth. But gas companies have no cause for alarm. The business of gas companies in and about Pittsburgh has grown rapidly since the introduction of natural gas in quantities so great that the ordinary mind fails to grasp their immensity. Natural gas makes business flourish in towns and cities favored with it, and general prosperity helps the gas companies. I would welcome natural gas to any city in which I have gas interests.

"How shall we economize?" is now the vital question of the day. Well, there are many little ways, perhaps, still left open by which we can reduce gas a fraction of a cent per 1,000 feet; but of the ways now open to us one transcends all others in its magnitude. *Increase your consumption, especially your day consumption.*

Did you ever compare the cost of distribution, per thousand cubic feet, for the months of July and January? Well, if you have not, I will tell you that it costs about twice as much in the former as it does in the latter month. Now, it is easier to introduce stoves for summer cooking than it is to do the same thing for winter heating. Put down your prices and you will put up your output.

Probably there has been no greater advance made in any branch connected with our business than in that of high power burners. The Lungren and the Wenham are most excellent lamps. They are economical, and, so far as I have observed, give satisfaction to the consumer.

Now a word to the superintendents and engineers, especially. Have we

* See JOURNAL, April 2, '86, p. 192.

* See JOURNAL, Nov. 2, 1835, p. 227.

made progress in acquiring knowledge during the past 12 months? I trust we all have. I have no knowledge of any business where the opportunities are so great for self-improvement.

Gas engineering embraces in its scope almost every branch of science. The day has passed when the young man can reasonably hope to rise in the profession without diligent study. A knowledge of physics and chemistry is almost, if not quite, an essential. The rule of thumb will no longer answer. Right here I would add a word to proprietors of gas works. You, gentlemen, can make no better investment than in that of purchasing a small library for the use of your managers. A \$500 library would meet almost every requirement. A \$50 library will possibly double the value of the services, to you, of your superintendent. Supply them with all the gas journals—orthodox and heterodox—and, above all, see that they attend the meetings of their gas associations.

In one respect our Society has been blessed beyond its merits. Considering the number of our membership, and that many are past middle life, our death roll is short. We chronicle during the year the death of only one member, that of Mr. John Anderson, gas engineer and retort manufacturer, of Ironton, Ohio. A committee will be appointed to suggest appropriate action.

Now, gentlemen, you are favored with a fine list of papers, all upon live subjects; and if we do not have an interesting and profitable meeting we will doubtless have only ourselves to blame.

Remember that you have not now that chief of all presiding officers in the chair; and, remembering this, try, in a measure at least, to compensate for it by assisting the presiding officer in the despatch of business. Speak rapidly and to the point, and speak distinctly, so that what you say may not escape the ear of the stenographer. Do not go too much into detail in your discussions; time is too precious for that. Above all do not move about or converse while another is reading or speaking. It is disrespectful to the speaker, and annoying to others who desire to hear all that is being said.

You will observe, from the printed programme, that we have quite a task before us, and that every moment of time must be improved, therefore I now especially enjoin upon you to be prompt to assemble at the hour named. It is not fair to ask a gentleman to read a paper—which occupied him perhaps days or even weeks in preparing—to empty or half-filled seats, hence it will be necessary for us to get to work at the hours named in the programme.

Thanking you, gentlemen, for the distinguished honor of presiding over your deliberations, and begging your indulgence for my shortcomings, we are now ready to proceed with the regular order of business.

On motion of Mr. Bushnell (the President insisted that the address be not referred to a committee) a vote of thanks was tendered the President for his address.

On motion, the President appointed the following

SPECIAL COMMITTEES.

Nominating Committee.—Messrs. A. S. Bushnell, P. W. Huntington, and R. R. Dickey.

Place of Meeting.—Messrs. T. Wood, W. A. Ross, and H. Padan.

Memorial Committee.—Messrs. R. H. Canby, A. D. Cressler, and C. Taylor.

RESPONSES FROM LETTERS OF INVITATION.

The Secretary read letters and telegrams, received in response to invitations to attend the meeting, regretting the inability of the recipients to be present at the meeting, from Messrs. E. Vanderpool, Newark, N. J.; C. W. Blodgett, Williamsburgh, N. Y.; C. H. Nettleton, Birmingham, Conn.; F. Egner, St. Louis, Mo.; A. W. Littleton, Quincy, Ill.; J. Somerville, Indianapolis, Ind.; T. E. Connelly, Pittsburgh, Pa.; I. Battin, Albany, N. Y.; C. F. Prichard, Lynn, Mass.; C. J. R. Humphreys, Lawrence, Mass.; A. C. Wood, Syracuse, N. Y.; and J. P. Harbison, Hartford, Conn.

The President—I notice that one of the newly-elected honorary members, Mr. G. G. Ramsdell, of Vincennes, Ind., is now in the assembly room. I am pleased to introduce him, and to say that we are happy to welcome him to membership in our Association.

Mr. Ramsdell—I am very much obliged to the Association for the honor conferred upon me this morning in electing me an honorary member. I had the pleasure of attending the meeting of the Ohio Association, at Springfield, last year, and am very glad to find myself with you again. I anticipate a pleasant visit.

Routine business having been disposed of, Mr. M. A. Gemuender, of Columbus, Ohio, read the following paper, entitled—

GAS COMMISSIONS.

I suppose that there is not a single gas company represented in this assembly, or even any in the entire country, which, during the last 15 or 20 years, has not had its share of quarrels with legislative bodies, been recklessly assailed by an ever ready press, and fought desperately against an adverse public opinion. As a necessary consequence this feverish state of affairs has, in a measure, retarded the development of our industry and hurt

both producer and consumer. How to reduce this condition to a normal state is a question which has been awaiting solution for some time. The latest remedy proposed is that of a State Gas Commission—not in the nature of a temporary relief, but as a final settlement of the gas question. Before considering the functions of a Commission I think it necessary to analyze briefly the cause of the distrust existing between us and our customers.

When gas companies first came into being their existence was shaky and their future doubtful. Coal gas as a means of illumination was an experiment, and had still to stand the test of time. The public were more interested in the success of the trial than in the amount of dividends obtained by those guiding it. This is somewhat corroborated by the fact that many companies were originally granted an exclusive privilege for a long period of years as an encouragement. It was only after gas, as an illuminant, had been demonstrated a complete success, and had become a staple commodity, that the community began to calculate the cost. An object once in sight, the next consideration with a careful man is to obtain it with as little expenditure of energy as possible.

In time gas companies became large and wealthy corporations, which fact drew upon them the jealous scrutiny of the public. Complaints became numerous; and, as was perfectly natural, the meter was one of the first causes of trouble. This resulted 20 years ago in the appointment of a State gas inspector; but of him more hereafter.

Under the liberal and exclusive contracts which were then granted as a stimulus gas companies made good dividends from year to year, which the public, as they had no means of knowing facts, magnified considerably. It seemed to them that no matter how hard times were, or how general the depression, the gas companies were as prosperous as ever. Judging from some of the discussions at the American Gas Light Association meetings, I am somewhat of the opinion that the privileges originally granted the companies, and under which they became so prosperous, had a tendency to spoil some of the managements; they began to consider, owing to long possession, as their undoubted right that which was only granted as a helping hand. Having struck a profitable field, they expect to be guaranteed an undisputed possession, and to make no concessions on their part.

It is an acknowledged principle in political economy that when a new industry arises which proves more remunerative than the average, capital will at once leave the less productive channels to engage in the new one. This added energy soon reduces these earnings to the average. Our industry is no exception to the rule, and I am confident that as long as our earnings are a noticeable degree above the average we will be harassed incessantly, not always by rogues and blackmailers, but by honest capital seeking investment.

I firmly believe that when the patents now protecting the electric light and telephone companies expire these companies will have the same fight on their hands which we are now trying to get rid of.

All arguments tending to prove that the best and cheapest light is only to be obtained through the agency of one company may, with equal reason, be applied to telephone service. Are we, then, to have a State telephone commission? Our patrons bearing up under real or fancied wrongs will naturally seek relief by the aid of an active competitor; and not only so, but the inventive mind will continually strive to perfect a mode to supersede the present system. If gas could have been sold at 25 cents per thousand cubic feet, I do not think that much time or brains would have been wasted in bringing forth the electric light.

Of course, in this paper I entirely ignore the oft-repeated charges of dishonesty on the part of directors and employees. During the 12 or 13 years I have been connected with our company I have never seen the slightest effort made to obtain a penny which was not honestly considered our own. In fact, it would be extremely foolish for a company to act otherwise.

In spite of the endeavors of many managers to please their customers, schemes seem to be always handy to stir up discord, and agitation continues. To effectually stop this a State Commission is proposed. This commission is to decide whether or not the local company is honestly fulfilling its obligations, and also to have power to accept or reject all applications to erect competing works, regardless of the wishes of the local parties. To pay a large sum of money yearly and endow a board with less power would be, to say the least, extravagant. Any commission which could be appointed would simply be an arbitration committee, and must be one of two kinds: (1st) one with power to enforce its decisions, as any ordinary court of justice; (2d) one the acceptance of whose decisions depends entirely on the good faith of the party soliciting them. The former is the one which I presume is selected by the gas companies in general.

If a commission is a necessity, then it may reasonably be assumed that neither the municipalities nor companies possess the requisite honesty or ability to make and carry out a just contract for the supply of gas; but where is the third party to come from that is to make good these defects? Surely government boards and officials as a class have never been especially celebrated for either wisdom or righteousness. All the papers favoring gas

commissions which I have yet been able to obtain simply give a list of benefits which may be derived by concentrating much power in the hands of the few individuals comprising a commission, but never a single well demonstrated principle from which can be deduced a reasonable assurance that this particular body will be any better than any other political machine.

"The thing to be discussed is not so much whether, by any amount of intelligence, it is *possible* for a commission to work out the various ends consigned to it, as whether its fulfillment of them is *probable*. It is less a question of *can* than of *will*." Much could be said in favor of a monarchy provided one were but sure of a good monarch.

I have often wondered whether the gentlemen favoring the curtailment of commercial freedom by means of State boards of control realize that they are asking something entirely at variance with our generally accepted political creed—viz., placing the responsibility along side of the power and benefits. It is not, as an Ironton (Ohio) editor puts it, merely a State regulating a corporation which is only one of its creatures, but a direct effort on the part of the State to take from the people the right of managing purely local affairs.

That cities and corporations, while in pursuit of their own welfare, occasionally make blunders and serious errors is not a sufficient reason for relieving them of the responsibilities connected with the making of contracts. Permanent advances in civilization were only brought about when the people were allowed to feel the bad as well as the good results of their actions, and thus learn from actual experience the proper line of conduct.

Chief Justice Taney remarked: "It can never be maintained in any tribunal in this country that the people of a State, in the exercise of the powers of sovereignty, can be restrained within narrower limits than those fixed by the Constitution of the United States, upon the ground that they make contracts ruinous or injurious to themselves. The principle that they are the best judges of what is for their own interest is the foundation of our political institutions." This opinion, although given in a case differing from the one under discussion, nevertheless enunciates a principle which is just as applicable to the affairs of citizens and of municipal corporations.

Before taking from the people and business organizations the right to exchange their earnings with whomsoever they may deem fit, it is absolutely necessary for the advocates of commissions to clearly prove that the third party to whom they are to surrender their freedom not *can* but *will* do more for them than they will do for themselves. A current "opinion" will not do. It must be more than one chance in two that a commission will be honest, as a perfect commission can at best procure but temporary good, while a bad one can cost a lasting evil.

Now as far as arbitration from a permanent, State-appointed body is concerned. It seems to me that no man is morally bound to accept the decisions of an arbitrator whose services he has not even had a chance of refusing, nor will he willingly leave any question for arbitration unless he is sure of one-half of the committee, and has reasonable prospects from the referee. As a private citizen would not trust his personal affairs to such an organization, I fail to see how it can give any better satisfaction in public affairs.

We have at present Railroad and Insurance Commissions, which have probably done some good, that is, when composed of good officials; but is anyone prepared to say what these benefits have cost the people? Even if railroad accidents are less in number than in past years, I think it would be very hard to prove that Railroad Commissions brought about the improvement. When people suspect insurance companies it is not because they have received valuable information from the State, but because experience has taught them to be watchful. Our present Insurance Commissioner, who has the reputation of being a careful and active official, has lately routed out some bogus concerns. In the long run, however, it is the hits that are scored and the misses never. Place opposite the amount saved by us by a timely exposure the sum paid all past officials in salaries, fees, clerk hire, office rent, etc., and which way will the balance go?

It must also be remembered that a commission once established is not so easily gotten rid of. History teaches that it will entail a heavy expense long after its services have ceased to be of value.

Mr. Greenough, in defending gas commissions, states that the Massachusetts Commission has absolutely *nothing* to do. This, in my opinion, rather weakens his cause. We all know that when a new political board comes into existence, as all eyes are turned toward it, the first appointments are generally good; but when a few years have passed and the duties have become routine, the appointments are of the ordinary political kind. Now let the office be a high-salaried sinecure, and it simply becomes a "snap" for political pets.

To illustrate my position I will give the history of the Ohio State Gas Inspectorship.

April 6th, 1866, the Legislature created the office of State Gas Inspector. The chief inspector was to be appointed by the Governor, and his term of office to be two years. He was to possess a "thorough knowledge of the chemical composition of illuminating gas, and the structure and practical

operation of gas meters." His duty was, "to inspect, examine, prove and ascertain the accuracy of any and all gas meters to be used for measuring the quantity of illuminating gas to be furnished to or for the use of any person or persons, and, when found to be correct, to seal, stamp or mark all such meters, and each of them, with some suitable device and with his name, the date of his inspection, and the number of burners it is calculated to supply; such device shall be recorded in the office of the Secretary of the State. * * *

"He shall not in any manner, directly or indirectly, be interested pecuniarily in the manufacture or sale of illuminating gas, or any article or commodity used by gas light companies, for any purpose connected with the supply of gas. * * *

"At the request of the Mayor or Aldermen of any city, or trustees of any town, he shall report if the gas is of legal standard, and sufficiently purified from sulphuretted hydrogen, ammonia, and carbonic acid, and shall not contain more than a specified per cent. of sulphite of carbon."

His salary was afterwards made \$3,000 per annum. He was empowered to appoint deputies in other cities who were paid in fees of 25 cents per meter tested, and upwards, according to size of meter. Gas companies were obliged to foot the bill.

Now, as is usually the case, the first appointment was a very good one. Prof. T. G. Wormley was the first inspector. He is a chemist of great reputation, a gentleman of excellent social standing, and fulfilled his duties perfectly through many successive administrations. At last, however, a change of party brought in a new expert, not of the same kind, but a politician from Wood county, who knew absolutely nothing of gas or meters; he placed in our city, as deputy, another expert who knew, in this respect, just twice as much as his chief. When this deputy began his tests he noticed that the indicator on the prover did not point to the same figure as the index on the meter dial. Now came the question. "Was it a plus or a minus test?" He and his assistant finally agreed to call it minus. When his test showed a meter more than three per cent. out of the way, he condemned it by chalking a cross on it, and placed it to one side. When our men noticed this they would slyly rub off the mark, place the meter in another lot, and the next time it was almost sure to pass "O. K." This man who was expected to tell whether or not gas contained an "excess of sulphite of carbon" never even realized the importance of even temperatures, but would walk into a room, knock the ice out of the prover, and proceed with his tests, which were, in fact, absolutely worthless.

When the political wheel again turned, and the inspector found himself about to be superseded, he declared the office of State Inspector a useless sinecure, and recommended its abolition, which the Legislature accordingly did, April 12th, 1876, just 10 years after its creation. This experiment cost the gas companies many thousands of dollars, and proved, as might have been foreseen, a decided failure. The Legislature now referred all disputes exactly where they belonged—that is, to the local company and council.

If after all it could be shown that this measure, which was gotten up with the best of intentions, had demonstrated to the public the accuracy of meter registration, the large sum of money expended might not now be considered a total loss; but I do not think that anyone will claim that this has been done, as nine out of ten consumers never knew that there was a State Inspector, or cared the least for his tests, if they did. As far as I know the abolition of the office was never regretted by anyone.

The reason given by some for taking from cities the right to manage their own affairs is that Legislatures possess a higher grade of intelligence than city councils. Now, this may be true when small towns and villages are under discussion, but I do not think it will hold good when our large cities are brought into comparison; and let me say right here that if a commission is needed it will be principally by the larger and not by the smaller towns. Who ever knew of a small town with opposition works? In fact I do not think that in our State we have a dozen cities whose companies are large enough to seriously fear a rival. In small towns where gas managers have the great advantage of personal acquaintance with every leading citizen, and nevertheless have an opposing works thrust upon them, I think it is no more than they deserve, as they are incapable of properly managing their affairs.

In our Council at Columbus, although we have our full share of ward politicians who will advocate any measure which secures them popularity, and amateur gas experts who are only expert in betraying their own ignorance, yet the majority of the members are known as successful business men who materially take part in the benefits and share the losses of our city. No council ever introduced or furthered more infamous measures than those presented by Allen, O'Myers, Cable and others. The recent Payne scandal also does very little toward showing the superior honesty of the Legislature. The present Legislature is composed of about 147 members. Of these about 76 are country lawyers and farmers. In fact there are only about 30 of the entire 147 who live in towns of 10,000 inhabitants or over. Now, is it probable that such a body can be safely trusted to regulate city affairs? Is

their experience in municipal questions sufficient to warrant our abdication in their favor?

In speaking of the success of the Massachusetts Gas Commission, which is, after all, at present but an unfinished experiment, Mr. Ramsdell says: "This fact conclusively shows that, under like circumstances, commissions may be formed and set in operation in other States; in fact, the combined influence in almost any State of those interested in gas stocks, if properly concentrated, can so affect legislation as to secure practically the measure desired—if that measure is equitable and just." Further on he says: "Indeed, it seems to me that one of the strongest arguments in favor of a commission is to call attention to the fact that there is so much legislative activity in many of our States. * * * Experience is teaching us that gradually we are approaching legislative control; that each year provides its quota of enactments bearing upon gas matters; that very few of these are of benefit to consumer or producer; that, when the effort of honest men, they are almost always born of a suspicion caused by an absolute ignorance of our business; that these laws, whether advanced by worthy or unworthy motives, are almost invariably annoying, pernicious, and costly to gas companies, and in many cases very closely resembling blackmail."

From the above I deduce that Mr. R. decries legislative interference when done by others, and proposes to stop it by doing a little of it himself; that is, to get in his blow first. It will not do to say that his action is purely negative, else in entirely stopping legislative activity he would do wrong, as he cuts off the possibility of good as well as of bad laws. I doubt if the public would enjoy his interference a bit better than he enjoys theirs.

On this very point Prof. Sumner expresses himself as follows: "The fashion of the time is to run to government boards, commissions, and inspectors, to set right everything that is wrong. No experience seems to damp the faith of our public in these instrumentalities. The English liberals in the middle of this century seemed to have full grasp of the principle of liberty, and to be fixed and established in favor of non-interference. Since they have come into power, however, they have adopted the old instrumentalities, and have greatly multiplied them since they have had a great number of reforms to carry out. In this country the party which is 'in' always interferes, and the party which is 'out' favors non-interference. The system of interference is a complete failure of the ends it aims at, and sooner or later it will fall of its own expense and be swept away. The two notions—one to regulate things by a committee of control, and the other to let things regulate themselves by the conflict of interests between free men—are diametrically opposed; and the former is corrupting to free institutions, because men who are taught to expect government inspectors to come and take care of them lose all true education in liberty." I for my part believe the less we have to do with politicians and the more we mind our own business the better for us. The history of the past is full of laws which seek to obtain something for nothing. If the principles which are the foundation of our government are correct, then all such things as gas commissions, Pugsley election, and Bohemian oats laws are fundamentally wrong. They simply seek to obtain a benefit for one while shifting the responsibility connected therewith to another. Instead of carrying out the spirit of pure democracy they are, in fact, socialistic in their nature.

I also believe that gas companies have a right to earn and declare 100 per cent. dividends, provided they stand only on their own feet and ask favors of no one; but in so doing the struggle for existence will be bitter and unceasing. The moment, however, we stoop to ask or accept a favor, that moment we place on our shoulders a new obligation and cease to be independent workers. I know that the proposed measure is not asked as a favor, but as a mutual benefit; nevertheless, when we ask a protection not accorded other lines of production we are seeking a special privilege, and I cannot see how this can be otherwise regarded. Whoever heard of drygoods merchants asking for a commission? Is there any reason why the sale of clothing should be any easier than that of gas? A successful merchant not only sells his goods at a reasonable figure, but is compelled to directly inform the public that he does so by means of skilled agents. What constitutes the gas business an exception to this general rule?

We claim for ourselves the same privacy of accounts accorded other houses. How, then, are our customers to know whether or not our prices are reasonable? How many companies, except during the excitement of a gas war, ever volunteered any statements regarding their profits?

We have in our city an organization known as the Board of Trade. This is an assemblage of a large majority of our best business men—those who pay the taxes, and who would be the main sufferers from bad legislation. Should the occasion ever arise, we could appear before them and be sure of a fair and careful hearing; and as our story is perfectly straight, and they have the welfare of the city at heart, we would be sure of their hearty and valuable support.

The policy of our company, during the last few years, has materially changed. We have lost much of our reserve. We occasionally answer newspaper criticisms, and take part in friendly discussions. Our manage-

ment has even delivered addresses and volunteered information to our customers, and I think it has made us many friends. This line of conduct is worth more to us than a dozen political commissions.

I think the time is not far distant when most cities will follow the example of London, and enter upon an exclusive contract with one company on the condition that its dividends will not exceed a given figure, and that its accounts will be regularly inspected by municipal authority.

As an incentive to improvement, the London Company is allowed to declare one-fourth per cent. more dividend for every reduction of one penny per thousand in price. This, is, however, open to one objection. The rate of dividend is calculated on the present system of gas making, and all future improvements, after allowing for the cost of advancement, instead of accruing to the consumer, as is the case in all other lines of production, is shared by the company. Now, there must come a time when the cost of gas making will reach the minimum, and then the consumer will have to pay that cost plus the cost of one-half the entire previous advances, which have already been paid for. I think it would be better to contract with the company at a definite rate for a definite time, and if any improvements are made allow the company the entire benefit thereof. When the agreement expires enter upon a new contract, with the improved system as a basis for figuring. This would operate after the manner of United States patent grants.

I have endeavored to show as well as a limited paper will allow that our present trouble is but the same as has been undergone by every other industry, and that these have only been allayed by allowing business interests free play to regulate themselves. If, however, gas companies in a disputed question desire arbitration, why go out of their own cities to appeal to some politician? Have they not men in their midst of such standing as to command the respect of everyone? Or can the people of Dayton, Ohio, only find such by sending to Massillon, or Covington, Ohio? A spontaneous and resident committee will always have a decided advantage over a permanent State-appointed board—

First—Because, being selected when everyone is interested and anxiously awaiting a settlement, they are selected with great care.

Second—There will be little time for bribery.

Third—The expense will be small, and ceases entirely when the matter in dispute is settled.

Fourth—Being members of the community, they will not only share the benefits of an honest and carefully administered trust, but also help pay the penalty of a mistake.

The last reason, which I consider the most important, is the very one a State Board would fail to come under. With the latter it is simply a question of dollars and cents. A good-sized bribe would be likely to find a taker, especially if the term of office is about to expire, and the salary to end.

Now, as we already have active competitors in the shape of electric lights, and oil, the public do not feel so entirely at our mercy as formerly. Under these circumstances I should not deem it wise to handicap our industry by trying costly experiments.

Discussion.

The President—You have heard a very able paper—one that evidently has had much thought given to its preparation, and it is valuable to us because it takes the other side of the question. We have heard only one side of the question in our Associations for the last two or three years. Probably no other man in the room is so well informed on the topic as our honorary member, Mr. Ramsdell, of Vincennes. We shall be glad to have him open the discussion.

Mr. Ramsdell—I was much pleased with the paper, and the arguments offered by the writer are certainly very weighty. The same arguments occurred to me when engaged in preparing the report* of the committee appointed by the Western Gas Association, which report was prepared after a careful study of the entire subject of gas commissions. I see we both agree on the fact that the English system is what we are after. One important feature noted by Mr. Gemuender is the difference which exists (because of the competition of electric lighting) between the present conditions and those that ruled at the time when the report was presented. In my own experience at home we have competing electric lighting companies that bothered our stockholders very much, but still they have tended to relieve us from many of the very difficulties referred to in the report. We have had less complaint and trouble last winter than we ever had before. Consequently I agree that the lapse of time has changed some of the conditions. I do not want to be understood now as saying that I do not favor gas commissions. My belief is as strong now as it ever was in that regard. The committee report said that in their opinion gas commissions could be made successful in some States, while in other States the reverse would rule. Mr. Gemuender very properly refers to Ohio. It has been and is my opinion that Ohio, Indiana, and most of the other Western States, are not yet ready for gas commissions. As was stated by the President of the Massachusetts Commission

* See JOURNAL, July 2, 1886, p. 5.

according to my understanding of a reported remark made by Mr. Greenough, the reason why the commissioners did not have much to do in Massachusetts was because the gas companies and the local communities were striving to meet the requirements of the law, and that the whole machinery was now moving in a satisfactory manner.

The President—We have with us Mr. Monks, of Boston, Mass., who is quite familiar with the working of the Massachusetts Commission. The Association would be glad to hear from him.

Mr. Monks—I am glad to be with you to-day, and have been accompanied by a gentleman, Mr. W. Eliot Fette, who is largely interested in gas investments in the East. I was a pleased listener to Mr. Gemuender's paper, for it treats of a subject about which we have much to learn. The English policy of regulating the gas business seems to have been a success, and I will say that we apparently have a state of affairs in Massachusetts differing from that existing in Ohio. We, in our section, feared the local rulers most—that is, those who govern the larger cities and towns. It is a settled fact that large amounts of idle capital seem to be controlled by those who seek to help you in those duties which you believe you can do better yourselves unassisted. I personally have sometimes been called in question in this matter, and I wish to say here I endorse heartily everything said by the President of this Association about single companies as opposed to competition. I am in accord in this matter with the gentlemen representing the Boston companies. For the 25 years of my official connection with the South Boston Company I have held to that principle. It is only fair to say that Boston had one element of weakness that could have been eradicated. Our city has prospered and spread until its extension rendered necessary the absorption of towns which at one time were widely separated from it. The result is that the plan of annexation gave to Boston no less than eight distinct gas companies. In my judgment these should have been amalgamated in one, or at most, two companies. I was interested in the matter, and my business interests being largely connected with gas manufacture, I proposed to step down and out, if by so doing we could accomplish unification. The excessive number of suburban companies, however, does not excuse the grant of two gas charters for the city of Boston proper. If the Massachusetts Gas Commission had been established, say, two years earlier than was actually the case I think the Boston situation would have been altered. However, I now believe that Massachusetts gas men need not have fear for the future. The sanction of the local authorities to allow the building of competitive gas works must also receive the assent of three men who are State officials. On questions of this nature the sentiment of those who rule the largely populated districts are opposed to us; but our State legislators are taken, as a rule, from the ranks of those who think studiously and act honestly. They are men upon whom we can depend. I can take but one exception to the present Massachusetts Commission, and it applies neither to the character of nor the disposition of its members to do right, which is this. I believe some one man of that commission should understand practically the science of gas making. I make this honest criticism of our commission because the matter is in the experimental stage in our State. I believe it is going to prove a great and abundant success. I think protection from raiders is a matter of great importance to you all.

Having alluded to something that happened at one of the hearings before the Massachusetts Commission in the case (now on) of the Worcester Gas Light Company, Mr. Monks said: Now, I say that if gas commissions are to be appointed in other States the pertinent question for you to consider is the character of your State Legislature. Are you better off in the hands of your local authorities; or are you better off in the hands of your State Legislature? In Massachusetts we are convinced and satisfied that men appointed by one worthy to stand as Governor of the State of Massachusetts will be those who cannot be bribed; but at least one commissioner ought to have a thorough knowledge of the subject of gas making.

The President—Will Mr. Fette, who, besides being familiar with the Massachusetts Commission plan is also conversant with the English laws, take part in the discussion?

Mr. Fette—I ought, in the first place, to disclaim any right to be called a gas engineer. I have had charge, in a general way, of several companies which I have been interested in, and if they have been successful I think I owe it entirely to the faithful services of my superintendent, who has always been ready to accept my suggestions when they recommended themselves to his good judgment. Therefore I do not feel qualified to appear before such a body as this and express an opinion. I can fully endorse what Mr. Monks has said with regard to the State Commission—so far as I know of its workings. I have had since its appointment a feeling of security against raids on the companies in which I have been interested, which I did not have before, because of the character of our city governments. I think the appointments made by Governor Robinson were excellent; and the chance now is that before we can be raided upon by outsiders, who want to share in the little prosperity that we have earned, we shall have a chance to be heard, not only by the local authorities, but also by the Commissioners—men who are en-

tirely disinterested either in the price of gas or in any other way, and who are therefore willing to listen to us impartially. If they will adopt the suggestions which have been made (as I think they will), and pursue a little different course in future from what they did in Worcester—that is to say, have their hearings open to suggestions to be offered by the companies, in order that they may learn what is really best for the public—I see no reason why they may not become a great success.

The President—We have heard from no Ohio man yet, excepting the author of the paper. I know they are exceedingly modest! Perhaps Mr. Denniston, of Pennsylvania, will tell us what he thinks of gas commissions.

Mr. Denniston—I can tell you very little, for we have had no gas commission in our State. I have been interested in the discussions had at the various meetings on the subject, in order that I might know how to look upon the matter if it were ever brought up in Pennsylvania. So far we have had no occasion for a commission. We put up the best way we can with the raiders. I am in sympathy with the methods proposed by Mr. Gemuender. If there are to be commissions at all, or if any outside control of our invested capital is to be made, I think it should be exercised by the municipal authorities. I think I would risk it with them rather than with the Legislature. I have had some experience with members of the City Council of Pittsburgh, and I claim them to be neither better nor worse than the common run of councilmen; but I do know that, as a class, they are unfriendly to capitalists and corporations. Upon the whole (I can only speak of what I have learned from reading), if there are to be commissions I prefer that they should be local rather than general.

On motion of Mr. Hamlin, a vote of thanks was tendered to Mr. Gemuender. [The motion was carried. At this point the Secretary said he wished to add his personal thanks to those members who kindly agreed to his request to furnish papers. In reply Mr. Gemuender said, speaking for himself, he came there to listen to the other papers. He had but contributed his share to keep up the general interest in the meetings.]

A recess, to terminate at 2 P.M., was ordered.

FIRST DAY—AFTERNOON SESSION.

On reassembling the President said that two papers having been presented on one subject they would be read consecutively and discussed jointly. The first, by Mr. G. W. Graeff, Jr., entitled—

GAS AND ELECTRICITY—TWO INTERESTS OR ONE?

is as follows:

The time has certainly come when the discussion of this question is imperative, and when it must be held with view to business prospects only. Prejudice and sentiment must alike be given to the winds, and the cold test of dollars and cents applied without fear or favor. The question is a business one solely.

Since the introduction of electric lighting as a means of artificial illumination, until within the past few months, there has been little between gas and electric interests in this country save direct and unreasonable antagonism. Some of the reasons are plain.

For many years gas had occupied the field as the general and practical artificial illuminant for domestic and commercial uses. From a small beginning the business grew into a settled and conservative industry, inferior in commercial importance and as a field of financial investment to the railroad and mining interests only. The combined capitalization of the gas companies of the United States runs high up into the hundreds of millions, as statistics easily show.

While in its earlier years the industry of gas manufacture met with many obstacles, and encountered conflicts and setbacks in its struggles for recognition and success in the business world, its growth has, altogether speaking, been rapid and enormous. With success, it became more and more conservative in its methods, and finally grew to look with anger and jealousy upon any proposed interference with what it considered its vested rights in the control and monopoly of the business of artificial illumination. It is not strange, therefore, that the introduction of the electric light, some half dozen years ago, met with jealous protest and vigorous objection from the gas fraternity. Nor were these sentiments subdued by the methods by which many of the electric light advocates endeavored to force their systems upon the public.

Like nearly all other inventions of promise, the electric light was seized upon by speculators, in many instances for the organization of companies that were thrown upon the public as ventures. Failures followed and were numerous, as was to be expected. On both sides of the Atlantic schemes, gigantic chiefly in their paper capitals, collapsed, and when inflated ventures came to grief the public was swift to condemn the entire industry as fraudulent, oftentimes to the great prejudice of earnest and honest men who were devoting time, talents, and money to the development of the new system, in endeavoring to place it upon a sound commercial basis.

Reasoning largely from the distrust of the unconcerned world, the concerned gas companies generally throughout the country became strongly imbued with prejudiced opposition to the new means of light, presenting the constant argument that the whole affair was a mass of gigantic scheming, unworthy of friendly consideration; while, on the other hand, its possible success meant the constant presence of a dangerous rival to the gas interests.

As if directly to increase this antagonism, many of the parent or manufacturing electric light companies persisted in exacting fabulous "stock concessions" and enormous profits upon sales of electric apparatus, for the rights to use their several systems. In this manner the local companies and users were handicapped with an enormously inflated capital stock, which rendered practically impossible the return of any profits to the legitimate investor, and, as a consequence, the business of electric lighting has been compelled to wade through a period of invention, development, scheming, and we might almost add, wholesale error, such as always attaches, in a greater or less degree, to the development of new and great enterprises wherein capital has to be sought from the world at large. The electric light manager who has labored earnestly and faithfully to reform the business from such abuses, and to place it upon a solid and legitimate commercial basis, has had neither a pleasant nor an easy task to perform, and has manifestly suffered from being considered to be in bad company.

During the past five years, invention has been an art assiduously plied, and the business has been greatly improved by a few earnest and determined men, who have loyally worked for legitimate development. Systems have been revised, apparatus has been improved and perfected, the cost of original production greatly reduced, and the prejudices of gas makers and their masters—the public—satisfied. The matter of electric lighting is now regarded generally by thoughtful business men as an established and honorable industry. Despite speculation, failures and the naturally expensive cost of development, the business has made its way from the realm of venture to that of at least moderate success.

The fact of this metamorphosis has greatly changed its relations to the whole commercial world. As a substantial and legitimate investment, there is now nothing that appeals with more force to capital, when organized upon a proper basis, unless it be the industry of gas manufacture. The combination of the two in one is irresistible.

To the gas companies of the country the electric light now occupies a higher and broader relation, and the more advanced of these have become satisfied that there should be no more antagonism between the two illuminants. They are either rivals or companions in trade, and the closer the association the better and more profitable for both interests, and for that other factor of importance to every gas manager—the consumer. The two methods should be combined and worked together in all cases wherein artificial illumination is supplied by a corporate or private concern. The reasons for such combinations are many and potent. I give a few:

Nearly every city and town in the civilized world, containing 10,000 inhabitants or upwards, has an established and successful gas plant. The organizations of these companies are complete. Their executive managements and labor system are in active operation. Generally such companies have a surplus of brain and sinew not taxed to full capacity to manage the company or operate the works. In a great number of cases, the gas company could operative an electric light plant with little or no extra expense for executive and manual labor. In many instances, hardly an additional man would be needed by an established gas company, in adding electric lighting to its business.

A majority of the gas companies have more land than is actually required for the operation of their works, and not infrequently surplus room in their buildings, that could be profitably occupied by an electric light plant. This would save all rent—an item that means from \$250 to \$2,500 per annum to the independent electric company.

Where a company has any difficulty in disposing of its coke at a fair figure, it can find a use for a goodly portion in the electric lighting service; and where coke meets with ready sale the employ of the quantities necessary for such fuel purposes would draw the line of demand more tightly and generally secure better prices for the portion sold. This, as a great soldier remarked of the tariff, is a local question.

A large proportion of the older gas companies have surplus earnings on hand sufficient to pay for an electric plant. This would enable the company to sell its electric light at a considerably re-

duced price from that necessarily charged by an independent company, the latter of which must earn dividends upon its capital stock, which will not average less than \$20,000 to \$30,000 for each 100 arc lamps it operates from a central station built upon modern principles. Where additional capital is required by the gas company, the amount would be far less than that needed by an independent electric light company. The cost of installation, and the saving thus made in organization and operation, would be sufficiently large to give the gas company enormous advantages over an independent organization. These advantages, in many instances, would include the declaring of dividends, when, upon the other side, none could be thought of.

It is not necessary to refer, save briefly, to the street lighting argument. It is acknowledged that arc lights in the streets cause increased use of gas for interior purposes. It is evident, therefore, that this arc lighting should be under the control of the party that is to benefit most from its use and efficiency. Again, it can scarcely be denied that for street lighting, where population is scattered, arcs are preferable to gas lamps. Long lines of pipe, for the simple purpose of supplying the street lamps, would not be necessary, wires being strung more cheaply than the pipe can be laid.

I do not think much of an argument presented to me yesterday, that gas companies generally take out their meters from premises wherein the electric light has been solely installed, unless paid rent for the use of said meters, and that this makes the consumer dependent upon the electric light at all times, thereby putting the electric lighting company to the expense of constant supply, and hence raising the cost "in the holder" of its light. I do not believe in taking meters out until the consumer orders them out, or until he becomes a radical opponent of the use of gas. The former is rarely the case, as there are few consumers who are willing to pin their entire faith to the supply of electric lighting from a central station; and the cheapest way to drive a customer to the other position mentioned is, in my opinion, to take out his meter. Even where the consumer seems wedded to the electric light, it is better to leave in his way the constant temptation to use gas, and to throw in his way the constant suggestion that there are ends to which gas may be consumed, other than the one purpose of illumination.

It has been suggested also, since arrival here, that, after all, the most powerful reason why the gas companies should adopt the electric light is that it will tend to make them popular. The matter of popularity is a perilous one. From the greatest of stories down to the humblest of circumstances over which the public hold control, the change from the cry of hosanna is an easy one; and especially so is the case in this country, where we have local reformers in every city, town and village, who are always seeking some Sindbad on whose neck to ride into temporary notoriety. I do not trust to popularity when, as has been the case within the past week, in my city, announcement of a reduction in the price of gas has been followed by the statement, in some of our largest dailies, that the meter wheels would now go round more rapidly than ever. While ignorance and vice go hand in hand, as they do in these cases, it is folly to dwell fondly upon the security of the bubble of popularity.

I am, too, more than ever convinced that popularity is but a bubble, since receiving the opinion of one of the best known members of the gas fraternity, a New York engineer whom all our Associations delight to honor, and who is supposed to hold the goodwill of the citizens and municipal authorities of his city by the most binding of ties. This gentleman stated to me, at the Boston meeting, that the chief reason why his company would not adopt the electric light until it was compelled to, was that it would tend to depopularize the company, and that he considered it much better to have the electric light as an open opponent than to have the gas company furnish it, and thus raise the public cry of "monopoly." At the same time, the gentleman named did not consider that the right to cry "monopoly" was furnished when his efforts kept a franchise from being granted to a rival gas company that proposed to enter his city, put up an expensive and permanent plant, and furnish, under guarantee, a gas of higher candle-power than did the company of which he has charge.

If there is anything in the cry of monopoly to fear, it will disappear when the consumer of light finds, as he must and will, that with the supply of electric lighting in the hands of the gas company he will secure better and cheaper service than is or can be possible under the present dual systems. Deeply rooted in the heart of the gas consumer, more firmly than his inherent love of opposition to the

powers that be, is his affection for his pocket-book, and the saving of the dollar is what will convince the consumer that the right course is being followed by a combination of the gas and electric interests.

I do not wish to be understood as indorsing the idea of better or cheaper illumination by means of the electric light. While this is generally admitted to be the case as concerned street lighting, I have never yet seen, nor do I soon expect to see the electric light that, for interior uses, will excel or seriously rival the Lungren burner. With the Wenham, to which our President flatteringly alluded in his address, this morning, I have little acquaintance; but am willing to accept his indorsement, which has no doubt been based on thorough examination and test. Nor do I ignore in favor of the electric light, the incandescent gas lamps that are now seeking the market. In at least two of these I have considerable faith, while the third is in hands that I feel will make a success of it. I do not ignore these weapons which the gas companies possess, or will possess, if a conflict of systems is to finally ensue. But I see clearly that the electric light is here and will stay here, as either for us or against us. Which is it to be? The consumer will demand the electric light—is now demanding it. Shall the gas companies comply with his desires and give him what he wants; or shall we tell him to go elsewhere for it? It is a poor grocer who sells sugar and refuses to handle cut loaf, because he imagines that he can compel his customers to take granulated or go to the "other corner." After a while they will go to the "other corner" too frequently for his enjoyment.

The question of fuel gas in connection with this subject of combined interest, is one of too much consequence to attempt to notice briefly; so I pass it by entirely, with the simple suggestion that the dovetailing of these interests, and the substantial aid in which the introduction of the electric light by the gas companies will give to the further use of gas for fuel purposes, is well worthy of more consideration than it has as yet received.

The question then is a plain one: With the knowledge that electric lighting has come to stay (and we might add in a broader sense that electricity has come to stay), and that it is growing to be more and more a commercial element, is it wise for the gas companies to leave its use, for good or ill, in the hands of those who have no interests in common with us? Is it not better that we should take it in hand, as an acknowledged ally and friend? It may be said that the gas companies of one State in the country have determined the ethics of this matter for themselves, and their example is worthy of imitation. Shall it be followed?

The second paper, by Mr. Thos. Wood, of Sandusky, on

GAS WITH ELECTRICITY,

is appended:

From the incorporation of "The London and Westminster Chartered Gas Light and Coke Company," in 1809, down to the present time, save the past two or three years, artificial gas has remained the most practical and advanced agent for illuminating purposes; and although its history, from its birth to the present time, is surrounded with opposition and bitter denunciation from the public at large, caused by actual or imaginary arbitrary dealings of the several companies engaged in the business, still we find its use has grown to proportions so large as to compel those engaged in its manufacture to believe that the industry cannot be materially affected by any rival which may appear in these times of new developments and inventions.

That the industry of gas making for artificial illumination will continue, no one will have a shadow of a doubt; but who can say that its rival, electricity, will not largely check the annual increase of output, which heretofore has been, with most of the larger companies, almost fabulous. It is true, we hear on all sides that in cities where electric light is supplied the gas companies sales have largely increased by reason of said electric plant; but is it an actual increase in dollars and cents? In other words, does the increase of output (if there be any) mean increase of profits? Have not prices been reduced to meet this rival, and in such proportion as to more than counterbalance any increase of output? Or, have not extensions been made into new districts and so brought the output up to its usual per centage of increase?

If such is not the case, and the same prices have been maintained as before the advent of electricity, and the increased output for the year still shows the same per centage as in previous years, then we

must admit that electric lighting has made no inroads, or, at least, visible encroachments, on the gas business.

It seems to me these can hardly be the true facts of the case; for if (for argument's sake) we say a dozen of the best consumers of a gas company in a small city substitute the electric light for gas, it seems there must necessarily be a loss of so much gas sold, notwithstanding the fact that some others may burn enough more to make up the loss, even were the same prices maintained. That is to say, it is a loss in that this dozen consumers have practically abandoned gas for some other illuminating agent, and are no longer patrons of the gas company, except, perhaps, in a small way; while the chances are that other business men will be tempted eventually to do the same thing by force of rivalry.

Let a business man of any city, a jeweler, for instance, light his store with electric light and the other jewelers in that city will, in all probability, do the same, whether it be more economical or not; and so it is with the clothing business, or any other particular line.

Some gas men still assert that electric lighting is only a craze, that its life will be of short duration, and that gas will once more be universally used. In Murdoch's and his contemporaries time many said the same thing about gas; but the candle makers and whaling interests could not stay the gas craze. This continued harping about dangers and unreliability of electric lighting will not stop the craze; for do we not find that the introduction of gas met with these identical objections, all of which vanished as its use became more general; and why should not the use of electricity become safer the more we become familiar with it? History testifies to the fact that nearly all new inventions or departures have to pass through the ordeal of ridicule, discouragement, opposition and, often, loss before the world is willing to admit their stability—a good deal as the child has to battle with the measles, mumps, and whooping cough before becoming robust.

Electric lighting of to-day gives better satisfaction to the public than it did four years ago; and why should not improvements make it still better four years hence? That there are dangers connected with electric lighting it would be folly to contradict, but our own business of gas making is equally as dangerous, if certain methods of manipulation are not carried out. As the electric lighting becomes more general undoubtedly it will become more safe—as the demands of the public are invariably answered by the inventor, at least in this country.

Gas men have put too much stress on the dangers of electric lighting, as well as some other less founded arguments, much as drowning men are said to catch at straws; but it looks now as though gas men were getting bravely over their prejudice, and will soon take to electric lighting "like ducks to water," if it be only to keep up their reputation as monopolists. If you doubt this look back to the files of your periodicals devoted to the gas interests and you will find that gas men (and I will not omit the editors) have been letting themselves down gradually until to-day we find a great many of the former already running electric plants, and as many more about to do so; and the latter (I refer to the editors) advocating this action. And why should this not be so? Being in the lighting business they are supposed to respond to the public demand, and there is no reason why, if a sufficient number of their patrons desire electric light in preference to gas, or in conjunction with it, that the gas companies should not supply it, provided they can get a return on their investment; otherwise, others will come in and supply the demand. Supposing the case of a manufacturer who, for 20 years, has been making a special line of goods for a large customer is requested by that customer to change the pattern. Would you deem it business policy to let that customer for 20 years standing go elsewhere, rather than cater to his wishes? I think not.

If there are any who have not yet made up their minds that the electric light has come to stay, I think they had better do so at once, and look about them to find the best means and measures to prevent its introduction from injuring their present industry of gas making. Aside from the gas field there are undoubtedly in most cities localities where it is desirable and necessary that the electric light be used, and gas companies can just as well meet this demand as let others do it, for the reason that gas and electric lighting are co-ordinate branches of illumination, and there should be no hostility between the two—and there would not be, provided both are supplied at a fair compensation by the parties supplying these two kinds of illuminants.

Most of the gas companies of this country are no doubt heavily handicapped by reason of too large a capital stock to contend with

electric lighting with low priced gas, while others may be so placed that the selling price of gas is necessarily high as compared with some companies more favorably situated. The residuals of one company may be a drug, while with another they may be a large source of revenue; coal may be available at much cheaper rates in some places than others; and again, the nature of the soil may enter largely into the selling price of gas, as in the district represented by the writer, where every foot of trench for pipe laying has to be blasted.

Electric light companies, on the other hand, have none of these things to contend with, except in slight degree; and practically it costs about the same to erect and operate a plant in any two cities of same size. The capital required for an electric plant, including the construction of lines, etc., to cover same area as a gas plant naturally would, is less than one-half that required for a gas plant, thus enabling an electric light company to reach the heart of the gas consumption at a nominal expense compared to what it cost the gas company to lay mains to reach same point. Another advantage over a gas plant is the fact that an electric light plant can be transported to another city without much difficulty, if so desired, while the gas works of a town is a permanent fixture. I refer more particularly, in speaking of electric lighting, to the arc system, which undoubtedly has met with better commercial success generally than the incandescent, at least, up to the present time. My aim has been to point out some of the advantages an electric light company has over a long-established gas company; and I think you will find they are facts, whether we wish to believe them or not.

In the matter of enlargements of works or extensions of gas mains we know what radical changes and expenses said enlargements entail. Sometimes the whole system of pipes, purifiers, station meter, holders, etc., have to be substituted by larger at great cost. Old mains which have become too small have to be taken up and replaced by larger, when extensions into remote districts have to be made. Not so with electric lighting, as it is only necessary to add another engine, boiler, or dynamo alongside of those already in, when you wish to increase your capacity. The far future has not to be looked into so closely, and consequently capital additions need not be made until such time as a fair revenue can be earned on the expenditure.

A gas works when first built is usually built with a view to future growth, say to meet the demands for ten or fifteen years hence. There we have a large amount of capital lying idle for a number of years before it is needed; and at the end of this time what do we find? That the same process has to be gone through of providing for another fifteen or twenty years. More capital stock is usually sold to make the needed improvements, but just about this time a demand for a reduction in price is made, and we have this difficulty to contend with—capital stock increasing and selling prices decreasing in the same ratio.

The depreciation of the two respective plants the writer considers to be in favor of the electric plant, although there may be those who have good reasons for thinking otherwise. This point will depend largely upon the construction of the respective plants and methods of running same. That there is a disparagement in the footing of the two rivals, in favor of the electric plant as we find the two to-day, is evident to the writer; but whether the future will cause this difference to widen or narrow, time alone can demonstrate. Unquestionably those who are engaged in the gas business, and have this interest in charge, are capable of making, and will make, rapid strides of improvement in the future; but we must not lose sight of the fact that those who are working in the rival field (and they are legion) have, equally with the gas men, the capacity of attaining still better results.

The question arises, how can a gas company, thus handicapped, expect to hold its own against this rival in the field? Shall we make up the loss by making extensions into new territories, and make inroads on the gasoline field as the electric light has made inroads on our business? or shall we reduce the price (already low) and try to increase our output in this way as many have already done? or shall we take the bull by the horns and run an electric plant in combination with our gas business? If we do the first it will entail large expenditure for mains and services in districts sparsely settled, or where the consumers would probably be small ones—the street lamps are scarcely worth considering, as the profit accruing from this source is very small, after allowing for leakage and interest on the outlay; and besides, an electric light company can at any time reach this new district, and light it in one-tenth the

time, and at one-tenth the cost for construction—in which case these new mains would be comparatively idle.

If we adopt the second measure, and reduce the price of gas with a view of inducing our customers to abandon the electric light, we must not forget that prices once reduced are seldom if ever recovered, and a reduction of ten per cent. in the receipts of a gas company is a reduction of ten per cent. forever.

Let us take the case of a small gas works, whose annual receipts for gas sold will amount to, say, *\$40,000, with the further understanding that this company is selling gas at only a fair margin of profit, and that the works are conducted in an economical manner. The capital stock of this company would be, taking \$5 per thousand of output as a basis, \$125,000. An electric light company is about to be organized in same city, and with a view of heading it off a reduction of ten per cent. is made, which would represent a loss of \$4,000 per annum, equivalent to nearly 3½ per cent. on amount of capital stock. But the reduction does not stay the operations of the electric light company, which goes on as if no reduction had been made, and the gas company finds itself out the \$4,000 per annum, and an opponent in the field, working night and day trying to wean the gas company's best consumers away, and with a good measure of success, and with the resultant warfare between the two interests.

Now, supposing this same gas company in place of reducing the price of gas ten per cent. had put in a small electric plant of say 50 lights, which, in round figures, would have involved a total outlay of about \$10,000, and supplied (before others came into the field) the demands of customers, its proprietors would have saved the \$4,000 and invested it in something that would have given them equally as good returns as their gas interest, besides satisfying their patrons and averting war with a rival. They could have reached out into the gasoline district, and other places where gas had never been used, and solicited electric lighting where it did not conflict with the gas interest; and when the city desired to light all the streets with electric light they would be in shape to put in a bid. Then what profit there was in electric lighting the gas company would be making; and if, as so many claim, electric lighting assists the sale of gas, you could not fail to have a bonanza.

Considering what little profit there is in lighting our cities with gas, at present prices, the writer thinks it a great advantage to substitute the electric light for this purpose, thereby making available for private consumption a large surplus of capacity at the works, and thus enabling a company to put off for several years any large expense for improvement account.

In operating these two interests as one it should be borne in mind that the patrons of the combination must be made to feel it is to their interest as well as for your protection; and this can only be done by furnishing the light used, of whichever kind, at a reasonable compensation, and by giving them the best possible service. A company operating a combination plant can afford to supply the electric light to its patrons at a reduced rate over a company organized for that purpose alone, thereby enabling the combination the opportunity of proving itself a benefit to the public. That a gas company can operate the two systems with less expense goes without questioning; and if the time comes when electric wires will have to be placed underground the gas companies will still have other advantages. Usually there is sufficient land around a gas works to locate the electric plant on without additional outlay. The same officers can have supervision over both; and, in a great many cases, other labor can be utilized without additional cost. Waste heat from benches will form another important item of saving in the production of steam. Electric plants are not difficult things to manage or manipulate; construction of circuits and wiring of buildings is simple and easily acquired. Street men can be worked in to dig pole holes, and will soon learn the method of framing, raising and setting poles. As a matter of consequence the better the construction the better will be the service rendered, as in our gas business. Those who go into the electric light business in a slipshod manner will find it a rough road to travel, and at the end of the year probably find nothing to compensate them for their pains. An electric plant to pay must be well planned, well built, and properly managed. No house-top or back-door construction work will give the patrons good service, but will only add to the dangers of the business. Good foundations should be placed under all machinery, if you wish to keep away from the repair shop, and everything must be kept in first-class order if we wish to make a success of it. A few words about construction of electric lines.

Of course you are all aware of the wide-spread prejudice which exists against the erection of poles in the streets of our cities, and there is, no doubt, just cause for this prejudice, owing to the indifferent manner in which the several line companies have done their work and neglected same after being built. Crooked and unsightly poles have been used where, at slight expense, better could have

*Presumed annual output 25 millions, gas rate, \$1.60 per 1,000.

been employed. These poles are, in a great many cases, never painted, and utter disregard of neatness to coincide with the surroundings has been allowed—all of which has hastened public prejudice. If gas companies that are contemplating the addition of an electric plant would make a special effort in starting out with their construction, and endeavor to improve on the past methods by showing more regard for the tastes of the public in this matter, it would prove largely to their advantages to so do.

As an instance in point. Our company, after adding the electric lighting to its gas business, was caused a good deal of trouble in the matter of obtaining right of way for poles—it being necessary to erect poles on some streets where other companies had failed to get permission. It occurred to the writer that, perhaps, if iron poles were used this objection might be overcome, so permission was asked of the proper authorities and readily granted. These lines were built about a year ago, and have given excellent satisfaction not only to the citizens but to ourselves, for the wires have always worked well, and have not been the cause of a ground in that time, notwithstanding the fact that we have had some pretty severe storms since their erection. The poles are simply 2½ inch ordinary wrought iron gas pipe, with an eight inch flange, screwed on one end, to form a foot. On top is screwed a 2½x1½ inch cross into which two pieces of 1½ inch pipe (12 inches long) are inserted to form the arms.

The outer ends of these arms are bitted with 1½ inch Tees, into which are inserted the wooden pins that receive the glass insulators. If it is found necessary to put on more than two wires a 2½ inch nipple, 12 inches long, is screwed into top of the 2½ inch cross at top of pole, and another set of arms put on in the same manner as before. When these poles are painted they have a very neat appearance, and, practically, take up no room on the sidewalk. The method of setting these poles is simple. A man first marks out the distances at which the poles are to be separated, then, being careful that the marks are all on an even line, he takes an ordinary post-hole auger and bores out the hole to the depth of five feet, which, in favorable soil, is done very rapidly. A little soft water line is thrown into the bottom of the hole, and the flange forming the foot is imbedded in its own weight, thus causing some of the water line to be forced up into the pipes, which, when set, acts as a plug to keep water from getting up in the pipe. After the pole is plumbed the space around it is filled in with cement and broken stone, to the surface of the sidewalk. When the cement is set the pole is very firm and will not turn in the flange. Care must be taken not to run any wire until the cement is sufficiently set, which will occur in, say, two days. For neatness and strength combined they are just the thing, and a pedestrian will scarcely realize there is a line of poles on the street.

The height of these poles is 20 feet above the walk, and is ample to escape traffic, etc. This is a very convenient height for branching off into stores, and will bring the light wires below all telephone and telegraph lines, when crossing at right angles. The writer thinks that this height is preferable to using very high poles, and going over other wires, for various reasons—one is that electric wires need more careful and frequent inspection than any others; and at the height specified the examination can be made more readily and thoroughly. Another is that the branches going into stores are shorter, and any defect in these can be seen from the walk. Of course guard-wires are necessary when passing under other wires at right angles, so that any other line breaking will be caught before reaching the electric wires. In constructing electric light lines care must be taken to avoid running under and parallel with other wires, if possible; and another important point to be borne in mind is that a single electric wire running parallel with, although on opposite side of street to, a telephone line will render the telephones almost inoperative. If you wish to avoid trouble it is better to see that this mistake is not made on the start. A loop or double wire, on the other hand, will not affect the telephone line in the least, as the induction of the one wire is neutralized by the other. I mention these ideas of construction for the benefit of any gas men who contemplate adding an electric plant to their present works, believing and hoping that the experience of over a year may be of benefit and deter some of you from making costly mistakes in the start. While speaking of this experience a few words about the plant itself may be of interest to some.

In the first place, see to it that all your foundations are of the best. It will be better to exclude foundations when making contracts for engines, shafting, etc., and attend to that part of it yourselves. Buy the material yourselves, have the work done by the day, and stand guard over the workmen (with a club, if necessary), while the work proceeds. Anchor bolts for engine and pillow blocks should not be less than 9 feet in length, if you wish to keep everything solid and in line. Do not set dynamos on a floor depending on joists for support, but fill up space between joists with concrete, letting some extend down three or four feet into the ground. This done you can lay floor over concrete, and place dynamo carriage on this. By doing so you will prevent any vibration of dynamos or building while running. Let your engines be from a good maker, and, for economy, a slow speed engine is to be preferred, provided said engine has a sensitive and reliable automatic cut-off. From 120 to 140 revolutions per minute is a safe and economical speed, and you will find the repairs account on such an engine to be small as compared with high speed engines—the necessary speed of dynamos being acquired by using a pulley, of large diameter, on engine shaft, and belting direct to dynamo—counter-shafting makes things more complicated; extra bearings have to be looked after, and no floor space is gained; extra power is used up and, unless in particular instances, has nothing to recommend it.

In selecting belts always get the best the market will afford. They should be endless of double thickness, and perfectly straight. A cheap or low-priced belt is liable to prove a very expensive one in the end. An Ampère meter should be used for each dynamo, so that the operator can see at a glance what current the machine is sending out. This is just as essential as a pressure gauge at your gas works. Purchase always a good grade of carbons suitable for the size of your current, and keep your lamps properly adjusted at all times. If all these points are carried out you cannot fail to produce a light equal to the best in the country, provided, however, the system used is a meritorious one.

The boilers may be set in retort house so as to receive the benefit of all waste heat from benches. This will save to you more than 50 per cent. of fuel required, as it set independent of benches. Poor grades of fuel can be utilized, such as coke breeze, slack coal, coal tar, cannel coke, etc., and the ordinary firemen can fire the boilers without interfering with their other duties.

The pumps and injectors (there should be both), should be in charge of the engineer running the engines, who should have his steam gauge, water glass, and try-cocks close to his engine, in addition to the steam gauge and water glass in retort house.

Supposing this combination of gas and electric lighting under one management to be a settled fact, it will not do for such a company to sit quietly down and depend on the safety the combination apparently affords, but to instill further vigor in the task they have undertaken, and extend, push and improve the business with the idea of affording, as soon as practical, a means of reducing the price of both commodities to their patrons, thereby securing the moral support of the community by your endeavors.

I would suggest that gas companies having any remote idea of some day adding the electric lighting to their present business do so at once, even if there is only a small demand for same in the localities in which they are situated, for the reason that other promoters, ever on the alert, will discover that demand, and by working up that locality get enough others interested to warrant the putting in of an independent plant. The latter once in operation, and the stock held by your own citizens not interested in the gas supply, will necessarily engender an opposing faction, not of a foreign element, but a party made up of your own people, which you are aware constitutes the worst kind of opposition.

The plant need not be of large proportions to start with, but sufficient to supply the demands of those who are the most eager for the new light. By commencing early, and in this small way, you will be enabled to control the entire field, which should prove a benefit to your patrons and assuredly a protection to yourselves. If you are too tardy, and turn a deaf ear to the demands of the public, you cannot blame them if they welcome the arrival of some other promoters, after which you may find yourselves, by force of circumstances, compelled to put in an electric plant, and with the difference that there is a lively rival in the field who you will be obliged to buy out, at perhaps a high figure, if you wish to secure a clear field, thereby making the cost of your addition unnecessarily high on account of your tardiness.

For some reason the subject of electric lighting has been, apparently, studiously avoided at the several Association meetings of late. Not even a war cry is heard, as in former years! What does it mean? Is it that gas men have tired of their sarcasm regarding the new light; or is it only a lull in hostilities, to be followed by more effectual action? I am inclined to believe this lull is simply time taken up to give gas men an opportunity of forming a new line of battle, whereby they may be enabled to capture the enemy's works and use them as their own defenses. The fact that a bill to enable the gas companies of this State to combine and operate the two systems of illumination (it has already passed the Senate and will shortly come up for passage in the house) is indicative of this line of action.

To those who at the present time are averse to this innovation in the gas business I have no apologies to make, sincerely believing that it is only a matter of a short time when all gas companies, both great and small, from Maine to California, will be running electric light plants, and running them well. I also believe that in a short period of time this and kindred assemblies shall be known by the broad name of the "Artificial Light (I am emboldened enough to add) and Fuel Gas Association." Some one has written that "a rose would smell as sweet by any other name," and I think we will run no risk of injuring the smell of our gas by this change of name. The fact prompting the prediction of adding fuel gas to the combination grows out of the knowledge that the steam generated for electric lighting only occupies a portion of the 24 hours, and the same boilers can be used, during the balance of that time, for making water gas for fuel purposes, or, if desired, for illuminating purposes. The coke pile in that event will not be a source of worry, as it is to some at present.

Of course I refer to gas companies remote from natural gas fields, and localities where piping from these fields would make the cost of the gas to the consumer greater than it could be manufactured and sold at by a gas company. And if the supply from these gas wells should cease or get weak in the near future, as so many of our scientists predict, then my remarks would hold good for all gas companies.

Thanking you all for your patience in listening to my feeble efforts, I will close this paper by remarking that with gas light and gas motors, electric light and electric motors, and fuel gas, I conscientiously believe that the future of gas companies never looked brighter than in this year of our Lord, 1887.

[To be continued.]

SPECIAL ENGLISH CORRESPONDENCE.

COMMUNICATED BY NORTON H. HUMPHRYS.

SALISBURY, March 10, 1887.

Gas Companies' Accounts for the Second Half of 1886.—The Competition of Oil with Gas.—Sulphate of Ammonia as a Manure.—Dr. Knublauch's Experiments on Limed Coal for Gas Making.

Now that the half-yearly meetings of shareholders have been held, and the directors of the various gas undertakings throughout the land have presented accounts of their stewardship during the six months, ended December 31st, 1886, we are in a position to notice the extent to which certain adverse circumstances, such as the fall in the value of residuals, the general slackness of trade, and the mild weather during the period in question, has affected the welfare of our industry. On the whole, the state of affairs is satisfactory. There are some unfortunate undertakings that have not been able to earn a sufficient balance of profit to make up the usual dividends, and are consequently obliged to draw on the reserve fund, or to resort to an increase in price. It will be interesting, by-the-way, to watch the effect of this policy on the quantity of gas consumed. It is so usual to look for an increase as an immediate result of a reduction in price that some curiosity is aroused as to whether the effect of a move in the opposite direction will cause any falling off in the consumption. But, while the reports of these undertakings are set in a minor key, and refer sadly to diminished receipts for residuals, a falling off in the consumption of gas, etc., there are many others tuned to a more cheerful strain. Not only has the balance of profit been maintained, but it is possible to announce further reductions in price in some cases. As an explanation of the apparent anomaly that some are able to reduce their price whilst others are obliged to raise it, we may notice that there is a great difference in the policy pursued in respect to various undertakings as to the adjustment of the price of gas. Some companies strain, perhaps, more than is good for them in the direction of "cheap gas." The moment their affairs admit of it a reduction is declared, perhaps without a proper appreciation of the fact that specially favorable circumstances have combined to produce a temporary inflation of prosperity. Sometimes we find even a step in advance of this, and there is a "reckoning of the chickens before they are hatched," by taking into consideration the increased consumption that may be expected to follow upon the reduction. Others are more cautious, and believing that a "bird in the hand is worth two in the bush," take care to have a good balance to the credit of individual profit before reducing their price. Sometimes the former policy is forced upon the directorate by adverse circumstances, such as excessive capital, etc. While fully believing in judicious enterprise, I would remind gas engineers that although reductions in price do not always meet with proper appreciation, any attempt to raise the price is sure to arouse opposition. A well-managed undertaking, having a capital account that has been kept within bounds, can usually afford to give a moderate reduction every few years as the business increases. This will be sufficient to show the consumers that their interests are not neglected, and that there is no desire to extract exorbitant profits; and will usually keep them more satisfied than a fluctuating price would. Such is the deduction to be drawn from the last six months' working. Those who sail too closely to the wind are the first to feel the effects of an adverse current; and so we find that some undertakings that have long been noted for cheap gas, and have consequently been as thorns in the sides of their less fortunate neighbors, are now unable to make both ends meet. The more cautious ones are able to pay their way comfortably, and perhaps to continue their custom in the matter of an occasional reduction, notwithstanding the unfavorable circumstances above mentioned.

An interesting report recently submitted to the Gas Committee at Dukinfield, where the gas works belong to the local authorities, by their manager, Mr. Harrison Vevers, affords some useful information of a novel character in connection with the supply of gas. It appears that the report is prepared in accordance with a desire expressed by the Committee some months since for information as to the various agents used for the production of artificial light in their district, having a special view to the effects of the increasing use of mineral oils on their undertaking. Mr. Vevers finds that, out of a total of 3,820 houses, 2,196 use gas, 1,600 oil, and 26 candles; and considers that the latter mode of illumination is not used to a sufficient extent to be of any practical consequence. But that oil is used in nearly 42 per cent. of the houses is regarded as an important matter, especially as there is reason to believe that its use is extending. Three causes are given in explanation of this. The first is that there is some dissatisfaction with the price charged for gas, because it is higher than the rate in force in a neighboring town. In the second place, oil is apparently cheaper because it can be purchased in small lots as required, whereas gas is paid for in a lump sum at the end of the quarter. And the third cause is the cost of fittings and meters. If the latter are not purchased, there is the rent to pay. In respect to the first cause, Mr. Vevers remarks that the loss on residuals, etc., has prevented

reductions in price which otherwise might have been made. As to the second, which applies chiefly to that class of the community who are in receipt of weekly wages, he proposes that the gas bill should be payable, if desired, in four weekly installments, commencing from the day of its delivery. On the third head, he remarks that the cost of fittings, etc., for gas is certainly high, as compared with that of paraffine lamps, which may be purchased for a few shillings each. Hitherto it has been the general custom for owners of houses to fit them up with gasfittings, but since the use of paraffine has become prevalent there is a tendency to drop this rule. And if this should be done it will often happen that a person who would otherwise prefer to use gas would be debarred from doing so because of the expense of the fittings, which he would not be willing to incur. As some assistance in this direction, Mr. Vevers gives several reasons in favor of abolishing the charge for use of meters, and supplying meters gratis. The 1,600 houses at present using paraffine would consume, on an average, 3,000 cubic feet of gas each; and, therefore, if their custom could be secured the annual consumption would be increased to the extent of nearly 5,000,000 cubic feet. The present price of gas in Dukinfield is 3s. 4d. (80 cents) per thousand cubic feet. Reference is incidentally made to the advantage of letting gas stoves and engines on hire. Although much might be said as to the advantage of gas, and the trouble attendant upon the use of oil, it is considered that this aspect of the question does not receive much attention. It is regarded from a pecuniary point of view only, and as such must be faced by action bearing upon the cost of artificial light.

It would be idle to attempt to deny that the use of mineral oil has increased of late years, chiefly because it is so cheap. This, however, applies only to the working classes; for if tradesmen and middle-class people generally can obtain gas at anything like a reasonable price they prefer to use it, and thus avoid the many risks and difficulties attendant upon the use of oil lamps. The oils which are offered at temptingly cheap prices are not altogether satisfactory in respect to purity. While there are few towns in England where the competition of oil has affected the gas supply to the extent that appears to have obtained at Dukinfield, it is well that the subjects treated in Mr. Veever's report should be duly appreciated. We may certainly point to the increased use of gas that has prevailed of late years as a conclusive sign that there is no cause for alarm; but, on the other hand, it is worth while to examine our books, with a view of ascertaining whether the increased use of gas stoves and gas engines may have served to cover any derelictions in the direction of the paraffine lamp.

One of the papers devoted to agricultural interests publishes a letter from Mr. E. W. Booth, the steward of a large estate situated a few miles from London, on the value of sulphate of ammonia as a manure for grass land. After trying bones and various other artificial manures with but little if any benefit, Mr. Booth tried the following mixture: One ton of sulphate, two tons of mineral superphosphates (coprolites) mixed with an equal bulk of fine soil, and sown upon the land during the last week in March, at the rate of 1 cwt. of sulphate to 2 cwt. of superphosphate per acre. This mixture was a decided success. All through the growing season it was easy to see where the mixture had been used, and on cutting the crop there was found to be a large increase in produce as compared with ground treated in other ways. The inclusive cost of purchasing and applying the mixture is estimated at about 21s. per acre, and the increase in produce so secured is valued at double this cost. Mr. Booth's experience agrees with other large agriculturists who have found that sulphate is preferable to nitrate of soda for mixing with phosphates and other mineral agents. And it is generally admitted that the best results are secured from mixtures which are capable of supplying the plant not only with nitrogenous matter, but also with phosphorus, lime, potash, and other necessary mineral ingredients. Mr. Martin, engineer and manager of the Barnet District Gas and Water Company, who supplied the sulphate for the experiment, is very wisely making use of Mr. Booth's testimony to the value of sulphate by having it reprinted in leaflet form and circulating it amongst possible users in his neighborhood. I hope the time will soon come when agriculturists will be sufficiently awake to their own interests to avoid the heavy expense of the carriage of manures from foreign ports by using that which is to be found close at hand.

Speaking of sulphate reminds me that there are several encouraging signs that the depression in the residual market has touched bottom, and that things are beginning to move the other way. Both tar and liquor are improving in value, sulphate having stood at something closely approaching £12 per ton for some time, whilst better prices are also obtainable for tar. Although it is not anticipated that the prices of 1881 and 1882 will ever be reached again, there is good reason to hope that the item "residual products" will assist the revenue of gas undertakings to a larger extent during the year 1887 than it has done during the year just closed.

Dr. Knublauch, the chemist to the Cologne Gas and Water Works, has been trying some experiments on the effect of mixing dry substances (especially lime) with the coal to be used for gas making; his attention having been drawn to the subject by the application of the Cooper coal liming

process in England. He finds that, working on a small experimental scale, the effect of uniting $2\frac{1}{2}$ per cent. of lime with the coal is to increase the quantity of gas to the extent of 5 per cent., but there is also a corresponding decrease in quality. This also applies to the coke, which is of course increased by the weight of the lime, but does not burn so well as the unlimed coke. The tar is poorer in quality and 10 per cent. less in quantity, but the ammonia is increased in about the proportion of 10 per cent. The production of sulphuretted hydrogen is diminished, and, on account of the increased quantity of ammonia, a larger portion is removed in the scrubbing and washing apparatus; and both these circumstances tend to reduce the amount of work remaining to be done in the oxide purifiers. But the carbonic acid is increased to the extent of 10 per cent.

ITEMS OF INTEREST FROM VARIOUS LOCALITIES.

THE BRECKENRIDGE CANNEL DELIVERIES.—Gas men throughout the country are naturally somewhat puzzled over the legal aspect of the Breckenridge cannal situation. The lawyers, the judges, and the proprietors (both American and English) seem disposed to make a football of this valuable Kentucky property; but the users of the product need have no fear as to deliveries of the cannal—in testimony whereof we submit the following, from an entirely authentic source: The application of the Kentucky stockholders in the Breckenridge Company (Limited) to the Circuit Court of the United States, at Louisville, has been granted. On Feb. 8 Graham Macfarlane, who, up to that time, had been acting as Superintendent and Agent of the colliery, was made Receiver, with power to authorize contracts for the current year. The position of Sales Agents for this cannal, which Messrs. Perkins & Co., of New York city, had occupied under the former management, has been continued by the Receiver above named. A formal decision upon the points in question between the American and English stockholders is expected in June next. All sales and engagements for cannal made under the Receivership will be carried out by *any* management which *may follow that decision*.

IT WAS THE ELECTRIC LIGHT COMPANY.—In our last issue we stated that the stockholders of the McKeesport (Pa.) Gas Light Company, believing that the high salaries paid the officers of the Company were absorbing the profits, were about to bring suit with the object of compelling the directors to open the books for inspection. The assertion was incorrect, and should have read the "McKeesport Electric Light Company" instead. The McKeesport gas investors are satisfied in all respects, both in the matter of management and returns. Mr. Wm. C. Neemes, Superintendent of the Gas Company, writes us that the residents who have tried the incandescent lamps are greatly disappointed with them. In fact, the greater number of those who tried the electric lighting plan have already returned to the use of gas.

MORE CONTRACTS FOR MR. WEBER.—Mr. Adam Weber, of the Manhattan Firebrick Works, this city, informs us that he has secured the following contracts: To furnish the Citizens Gas Company, Rochester, N. Y., with all the necessary fireclay materials for 6 benches of sixes, the same to be fired with the new and improved half-depth Weber regenerative furnaces; and to construct 2 benches of threes (under conditions similar to the Rochester contract) at the works of the Glens Falls (N. Y.) Gas Light Company.

TAXES WITH A VENGEANCE.—Mr. E. H. Jenkins, the go-ahead gentleman who superintends the business of the Columbus (Ga.) Gas Light Company, writes: "I notice an item in your valuable JOURNAL the tenor of which leads me to infer you think it strange that the authorities of Virginia City (Nev.) should wish to impose a special tax on gas companies. I herewith send you a copy of the tax ordinance of Columbus, and from it you will see how nicely we are taken care of by our City Fathers." [From an examination of the ordinance we find (1) that gas companies are obliged to pay into the city treasury, each year, one per cent. of their gross receipts. The method of enforcing payment, *vide* the words of the ordinance, is as follows: "If any persons, firm or corporation shall fail to make a return of their sales, earnings, and receipts as required above, within ten days after the 1st days of January, April, July, and October respectively, they shall be summoned before the Mayor's Court, and shall be liable to a fine of \$10 for each day's default thereafter, in the discretion of the Mayor; and if any person, firm, or corporation shall make a return which, in the judgment of the Finance Committee, is considerably less than should be returned, the Committee shall assess such amount as they may deem just, and, if the party so assessed shall object to such assessment, they may produce their books, and the whole matter be referred to Council for their determination." In another section we find, under the heading of "special tax," that each electric light company shall pay an annual license fee of \$25; but each gas company must pay \$100 per annum—they ask pawnbrokers to pay only \$150—in advance. Plumbers must pay \$25; and in addition "every plumber and gas

or water fitter, or firm or corporation engaged in the work of laying pipe, shall, by the first day of March, make and file with the Clerk of Council a bond in the sum of \$1,000," etc.] Taking up the thread of Mr. Jenkins's letter, he further writes: "Notwithstanding the zealous care exercised over us, during the past year we have been enabled to pay a 6 per cent. dividend, and, in addition, to expend about \$3,500 in extensions, etc. Our annual output is about 10 million cubic feet. Our leakage account (1,389,000 cubic feet in 1885) has been brought to 1,005,000, or an average of 10.27 per cent. Our consumer's list shows, for year, an increase of 16 per cent., and we made a 10 per cent. reduction in our selling rates. So, you see, we are not only alive but prospering, as we are glad to know is the case with a majority of our brethren in the gas business." We did think it strange that Nevada City should attempt to tax any manufacturing company (gas or otherwise) in the manner proposed; but our impression was tempered somewhat in the understanding that Nevada City was in a pretty bad way for money, and had to have it by hook or crook. Georgia, however, it is popularly supposed in this locality, is anxious to attract Eastern capital—but, come to think of it, Columbus may bear a relation to the rest of Georgia similar to that existing between Canarsie and the balance of the Empire State. The leakage account returned by Mr. Jenkins will have especial interest if one remembers the paper read by him at the last meeting of the Western Gas Association (it will be found in our issue of July 2, 1886, p. 3) on his initial experience at the Columbus works. Without going into any extended mention of the facts, we may explain that when Mr. Jenkins took hold of the Columbus plant he found that (on a total make of 9 millions) in 1883 the leakage account had averaged 27.3 per cent. In view of his returns under that head for 1886, we submit that the salary paid him cannot be considered a heavy burden by the owners of the Columbus works.

THE MINNEAPOLIS (MINN.) EXPLOSION.—About three weeks ago the Associated Press despatches conveyed the news that an explosion at the Minneapolis gas works had caused serious loss to life and property. As usual, the Associated folks managed to get matters pretty badly mixed, and in order to secure trustworthy information about the disaster we applied to a gentleman connected with the Company for details of the affair. Through his courteous attention we are enabled to present the following: "The explosion occurred at about 4:30 P. M. of March 11th, and it is really strange that its effect was not more serious. It occurred in a scrubber, but recently constructed, built of one-quarter inch boiler iron, 6 feet in diameter and 20 feet high. A diaphragm divided it into two compartments, and a 20-inch outlet at the left connected it with a similarly-sized tubular condenser. The scrubber was filled with 4 in. by 4 in. lumber, cut in blocks 8 inches in length, and separated by a space of $1\frac{1}{2}$ inches. In ordinary working—that is, when gas was being manufactured—the gas would enter at the left, and base, ascending and passing down and out, at the right and bottom, through a 20-inch valve, thence through about 130 feet of pipe on to our coal gas pipes, which latter were fitted with a second valve. At the time of the explosion both these valves were shut. To begin with—this water gas plant is not yet completed, consequently it is in the contractor's hands—a mechanic and his helper, who had been employed for the day from a neighboring shop, were fitting a smooth-faced door on the left of the scrubber. Needing the aid of a light for the purpose in view, one of them (the mechanic) ignited a match, and as he did so the explosion occurred. The door swung back and broke his skull—the unfortunate man died the next day—and the helper was burned somewhat, not seriously, however. The shock tore out a piece (2 ft. by 4 ft.) from the middle of the right compartment of scrubber, swinging it back like a door, and the blocks were thrown out promiscuously, striking many people in their flight. The cover, of steel plate, 6 feet 4 inches in diameter and $\frac{1}{2}$ -inch thick, broke loose from the *condenser*—it carried 54 five-eighth-inch bolts with it—sailed through the iron roof of the building (breaking off a heavy T-beam), and ascended into the outer air for perhaps 70 feet. In descending it crashed through the other side of the peak of the roof and onto one of the 11-foot cupolas on which five men were at work finishing up the lining. The falling plate hit one man—a brick mason, who lived but a short time after receiving the blow—and lodged on the cupola top as if placed there by hand. The damage to buildings and scrubber is but trifling, and were it not for the loss of two human lives—good men and mechanics—the affair would not be thought much of. The coroners inquest lasted two days, and the verdict was, 'Caused by a gas explosion.' We are yet at a loss to determine the cause of the disaster, and have no 'theory' to advance. We had made no gas as yet in the works; both valves were closed tight at our works and water gas plant. These are the facts just as they happened; and as the new plant is not yet ours, we do not consider it our disaster, nor do we place any blame."

THE MANUFACTURE OF PURIFIER TRAYS.—The tray business is more of an undertaking than most gas men suppose. At the establishment of Mr. Jno. Cabot, Nos. 306 to 310 Eleventh avenue, this city, where the manufacture of

trays is carried on exclusively, at least six workmen are constantly employed, that number being, of course, largely exceeded during the busy season. Special machinery is used to further the work, and trays of all sorts—for scrubbers as well as purifiers—are turned out in large quantities. Mr. Cabot reports sales, in last year, to over 100 gas companies, and he also notes that thus far the inquiries for current year greatly exceed those of the same period in 1886. The old motto, "The best is the cheapest," seems to apply to tray work; and there can be no doubt that the Church tray is meeting with phenomenal success. Orders for it are received from all parts of the world; and England has proved such an exceptionally good field that an agency has been established there. The essentials of a tray are that it shall be strong, light, retain its shape in use, not obstruct the flow of gas, and, withal, be easily repaired. These points seem to be covered by the Church style, and therefore it has met with deserved success. Mr. Cabot does not sit still with the advent of new methods of purification, for he has devised a tray, having rectangular slats, to be used where iron sponge is employed as the purifying agent. The new specimen, by means of an ingeniously-devised plan of grooving the exposed surface of the slat, holds the iron in such way as to prevent it from sifting through—a cause for complaint in the old-style tray. The trays are now fitted with three malleable iron cross-bars—one in center and one on each end—thus protecting the ends of the slats from breaking. Mr. Cabot's work is well known for its good quality, and to that feature much of his success is due.

CHEAPER GAS FOR DALLAS, TEXAS.—Not long ago we published in these columns some account of the manner in which Brother Enfield was "carrying on" in his portion of the Lone Star State, and we are right pleased to be in position now to say that Dallas gas matters are enjoying a genuine "boom." Some time since the proprietors of the Dallas City Gas Company published the news that from and after April 1st the net rate would be reduced to \$2.50 per thousand cubic feet, provided accounts were settled within eight days from date of presentation. At the same time they gave notification that the officers of the Company were ready to receive communications, to promptly answer all inquiries leading to the introduction or extension of the use of gas in stores and dwellings, and, if necessary, would send an agent to confer with those so asking. The notice closed with the intimation that "Gas fitting would be done at cost," and that "gas fixtures would be sold at a discount." The result of the pronouncement has been such that, on date of March 15, or 16 days before the new scale would go into effect, Brother Enfield had for days back been putting in an average of two new meters per diem, and three gas fitters were working overtime in the attempt to keep up with the demands of those who wished to have their houses piped. In his courteous note to us on the subject Mr. Enfield says: "Our people are pleased with the prospect; and I might add so also am I." The new Dallas rate is quite a cheap one, and the local gas proprietors will have no reason to repent of their move. The former gross rate was \$3.30; net, \$3.

CHEAPER GAS FOR SCRANTON, PA.—We are indebted to Mr. G. B. Hand, Secretary of the Scranton Gas and Water and the Hyde Park Gas Companies, for a copy of the following, which bears date of March 10, 1887: "In pursuance of the policy of these Companies to reduce rates from time to time, as may be warranted by increased consumption, notice is hereby given that from April 1st, 1887, the price of gas will be \$1.40 per thousand cubic feet, subject to the following discounts: 5 per cent. on all bills where the consumption for the month amounts to less than \$10; 10 per cent. on all bills amounting to \$10; 15 per cent. on all monthly bills amounting to \$25 and over—provided the bill is paid on or before the 20th of the month in which it is presented."

CHANGES AT WILMINGTON, N. C.—It was not a great while ago when the Wilmington gas folks were distilling wood, but the process, besides being decidedly uneconomical, gave poor satisfaction to the consumers. When the change to coal was made the business of the Company rapidly increased, and with that accession came the necessity for enlarging the plant. The improvements and extensions have been carried along without haste, but now the work is nearing completion. A stack of fives has been added to the carbonizing capacity, and the retort house now can be depended upon to produce 130,000 cubic feet per diem. Messrs. Gautier & Co., of Jersey City, N. J., supplied the retorts and fireclay material. A holder, located in the vicinity of Surrey, Castle, and Front streets, calculated to store 66,000 cubic feet, is now in process of erection, and when completed the Wilmington Company will have remedied one of the most harassing features connected with its former supply conditions. About 1,200 tons of coal are annually carbonized at Wilmington, some Pictou coal being included; which is strange when one considers the ease of securing Kanawha coal at that point. The business of the Company steadily prospers, and its proprietors are to be congratulated on having enlisted the services of two energetic men, in the respective persons of Secretary and Treasurer R. J. Jones, and Superintendent J. W. Reilly.

SANTA ANA (CAL.) HAS A GAS COMPANY.—The Santa Ana Gas Company was incorporated in 1886, with a capital of \$50,000. It is officered as follows: President, N. Palmer; Vice-Pres., C. W. Humphreys; Secy., M. A. Dunham; Treas., W. S. Bartlett. Santa Ana is in that most beautiful, fertile, and fragrant garden spot of California contained within the boundaries of Los Angeles county, at a point about 6 miles south of Anaheim (the latter is located on the Santa Ana river, some 8 miles from the sea and 25 miles southeast of Los Angeles.) Santa Ana is the center of a rapidly developing agricultural district, and is bound to become a most important flour milling district. In 1870 the post village contained but 750 souls, whereas now it can be depended upon to afford plenty of business to those interested in dispensing the light of the present.

IN THE HANDS OF THE JUDGES.—The Worcester (Mass.) gas hearing before the State Gas Commission, according to the testimony, seems to have been in the nature of a tempest in a teapot. We fail to see, as said before by us, that the complainants made out any sort of a case, save perhaps in the item of a deficiency in the Worcester Company's distribution system in one or two sections of the city. It is about time that the owners of large factory buildings comprehended the fact that a half-inch riser cannot be "depended upon" to supply a sufficiency of gas to 100 gas burners, be the latter ever so small. Even admitting that some 700 or 800 feet of the Worcester Company's main pipe was of improper diameter, their sin is but trifling when placed in comparison with the plumbing practice of some of the complainants' witnesses. It is expected that the Commission will shortly render a decision. Until that is made public we refrain from further comment.

CHARTERED AT LEAVENWORTH, KANSAS.—It is understood that, on March 22, the City Council of Leavenworth, Kan., passed an ordinance chartering the Leavenworth Lighting and Heating Company. It is further reported that Mr. Soerates Newman, of St. Louis, Mo., is the one most interested in the venture.

STREET LIGHTING AT NEWPORT, R. I.—In response to the invitation of the Committee on Street Lights of the Newport City Council, the Newport Gas Light Company, through Treasurer Quinn, submitted the following: Not less than 350 street lamps, including lighting and cleaning, at the rate of \$1.80 per thousand cubic feet; but if 600 lamps be maintained, the charge to be reduced to \$1.50 per thousand. Gas supplied to public buildings to be at the rate of \$1.70 per thousand. Last year five miles of Newport's streets were lighted by electricity at a total cost of \$15,421.46; whereas 30 miles of street gas lighting cost but \$7,740.67. An average cost per mile, for the former, of \$3,084.35, against \$258.02 for the latter. It costs something to be fashionable.

CHANGED HANDS.—Messrs. E. T. Watkins, Theo. Forstall, L. Z. Leiter, A. Keep, Y. L. Yoe, J. N. Jewett, S. B. Cobb, J. Beecher, B. L. Smith, J. A. Brown, Jr., and J. de Koven, in March last resigned their positions as Directors in the Chicago Gas Light and Coke Company. Messrs. C. R. Cummings, S. A. Kent, J. Cohrs, C. T. Yerkes, P. A. B. Widener, W. L. Elkins, W. C. Goudy, Theo. Forstall, and J. Rehm were thereupon elected to the vacancies, and the Philadelphia syndicate were thus put in control of their new purchase. The new management subsequently elected Mr. Theo. Forstall to the office of President of the Company. It is understood that the schedule of rates will be revised, but it is not surmised that the new price will be other than an equitable one.

DEATH OF MR. SHERWOOD.—Mr. John H. Sherwood, who will be remembered by the gas makers of this city for many a day, died at his home on the morning of March 17. Deceased was a native of New York, was born in 1816, and had amassed a large fortune in various mercantile pursuits. Personally, he was well liked. He was one of the original founders of the *Sun* newspaper. He had held many important positions in financial institutions, and was a great believer in the value of New York city real estate.

NOT UNLAWFUL TO BOYCOTT A GAS COMPANY.—The London *Economist* says that a curious suit has just been heard before a Paris (France) civil court. The gas company which supplies the town of Rambouillet having refused to reduce its price, a great number of the inhabitants entered into a compact to abstain from burning gas, and imposed a penalty on any members of the league who should secede from the agreement. The company brought a test action against one of the members, claiming damages for an illegal coalition, pretending that it was an infringement on the liberty of trade, but failed, as the court held it had not been proved that any unlawful coercive means had been exercised on any individual member.

TO BUILD A HOLDER.—The Washington (D. C.) Gas Light Company has applied for permission to locate a gasholder tank in "Square No. 1,020," the excavation to be 140 feet in diameter and 30 feet in depth. This looks as if the Washington folks were about to construct another big gasholder.

THE BALTIMORE (MD.) GAS WAR.—Another sortie has taken place in the Baltimore gas siege. The Equitable Company announces a reduction to 35 cents per thousand cubic feet, and much confusion is the result. It would seem rather illogical, in the face of this move, to predict that the end of the Baltimore gas war draws nigh; but, illogically or otherwise, we nevertheless incline to the belief that those who purchase Baltimore gas shares at current rates will have no reason to look forward to a spell on the stool of repentance.

EXTENDING ITS SPHERE.—The Clinton (Mass.) Gas Light Company asks permission to increase its capital stock in order that it may supply gas to the inhabitants of the neighboring town of Lancaster.

GONE TO — ?—Walter E. Lawton, formerly of this city, is an object of extreme solicitude to many hereabout and elsewhere. Of course, we refer to the party who left New York rather suddenly, leaving debts to the tune of a million or over. The absconder was the leading spirit in the Gate City Gas Company, of Atlanta, Ga., and we opine he did not find much profit in the venture. Brother Helme, of the old Atlanta Gas Company, is evidently a good fighter. [The Company has been placed in the hands of a receiver.]

HARTFORD (CONN.) NOTES.—Gas at \$1.40 per thousand is pretty cheap when one considers the situation and surroundings at Hartford, and shows how progressive the management of the Company has been. Bnt Brother Harbison is not yet satisfied, for he means to come down once more in the near future. In order to accomplish this object extensive alterations are now in progress at the Hartford works, one of the principal items being the construction of a new retort house on the site of the carbonizing plant dismantled some years ago. To secure a firm foundation for the new structure some 800 piles had to be driven. The house will contain eighteen benches of sixes, to be fired on the regenerative principle, and it is fully expected that by the 1st of September the plant will be in working order. The new Standard Washer-Scrubber was put in duty about two weeks ago, and is giving satisfaction. In 1878 the Hartford rate averaged \$2.61½ per thousand; and the present conundrum is, what will the decennary of that year disclose in the matter of selling price? We might also note that the petition of the Hartford Company to the Legislature asking permission for a charter amendment to enable the Company to supply electric lighting, was, on March 23, favorably reported on by the Senate Committee.

HE DID NOT MEAN IT.—About ten days ago the New Orleans *Picayune* contained a statement by a merchant of that city who claimed he had, some years ago, been presented by the Gas Company with a bill for \$62 on account of a month's gas supply. He paid the bill under protest, and asked the Company to give him a new meter, which was done. Next month the inspector called, looked at the meter, and said, "No gas burned this month, eh?" The merchant made no reply. A similar state of affairs went on for a year or so, when the merchant told the inspector "that he had been using gas all along, but guessed the meter didn't register it." The story is remarkably diaphanous, nevertheless the *Picayune* man took it all in, as did other newspapers, who reprinted the "confession" as an instance of Crescent City shrewdness. Some days after the merchant acknowledged he had only been hocussing a reporter; and the inference, at this distance, is that the merchant had been drinking levee water. Now let us see if the newspapers which circulated the "confession" will devote equal space to the recantation.

Correspondence

[The JOURNAL is not responsible for the opinions expressed by correspondents.]

A Dissenting Opinion from Cadiz.

OFFICE OF GAS WORKS, CADIZ, SPAIN, Feb. 28, 1887.

To the Editor AMERICAN GAS LIGHT JOURNAL:

Having read in your JOURNAL (issue of Nov. 16, 1886, p. 296) Mr. Mayer's paper on the Munich regenerative bench, I ask that you kindly give space to the following.

For about 30 years the people of Cadiz were supplied with gas from a works built by French capitalists. Originally the price charged was at the rate of 34 centimes per cubic meter, subsequently at 28 centimes, or about \$1.95 and \$1.61 per thousand cubic feet. The illuminating power was unsatisfactory, and the street mains—these were of sheet iron covered with asphalt—were so imperfect that, under moderate pressure, over 30 per cent. of the gas was lost through leakage. The purification was wretched and the service abominable. No wonder, then, that loud complaint was made by the consumers; but the French capitalists, refusing to take measures to abate the trouble, were soon rudely distrubed. Several prominent residents of the

city organized a gas company, capitalized in one million pesetas (about \$200,000), and asked for bids for the erection of a thoroughly equipped modern gas plant. In response 18 tenders were received. Preliminary examination resulted in the rejection of six of these; the second scrutiny brought the number to five; the third reduced it to three. Of these that submitted by the firm of Aug. Klönne, Dortmund, Germany, was determined upon. In the opinion of the committee the Klönne proposition best met their ideas in regard to practical arrangement and details of construction. The awarding of the contract was also influenced by a statement of the magnificent results obtained in many gas works where the Klönne furnace was in operation.

The Messrs. Klönne completed their contract in due time; and as I was appointed to the superintendency of the new Cadiz plant, I beg leave to submit the following statement (average for three months) of the results obtained:

Yield of gas per ton (2,240 pounds) of coal carbonized..	10,753 cu. ft.
Yield of coke per ton.....	1,568 lbs.
Coke used as fuel per 100 pounds of coal carbonized...	10.653 lbs.

The Klönne furnaces not only offer all the advantages of the Munich ones, but are more simple. Their generator, placed immediately under the retort bed, and not projecting beyond the front walls of the bench, is better liked by the men, on account of its lack of bad effect on their systems. In that respect it is superior to the Munich practice.

The Klönne regeneration occurs on each side of the generator, and is so arranged that the waste gases are traversed, horizontally, on their straight, downward curve, through the entire depth of the bench, by the secondary as well as the primary air, in zig-zag passages. The air absorbs completely the heat of the waste gases, which latter enter the main flue quite black and cool.

The carbonic oxide produced in the generator enters the interior of the generator arch, and combines in combustion with the previously heated air from the regenerator. By this means the generator is worked comparatively cool. The intense heat being created on the outside of the generator only, the latter will in consequence last as long as the arches of the ovens, and so require no repairs of any kind. The regenerator, being of substantial construction, will even outlast the generator, the recuperator bricks being so connected as to preclude the possibility of their cracking and allowing the gas to pass through the joints. Taking into consideration that the generator is below the retort beds, radiation of heat is wholly avoided. The entire front of the oven is easily accessible, which facilitates the attendance. In favorable contrast to all other systems these furnaces can be approached without the slightest discomfort, on account of heat, and the stokers are not subjected to the danger and annoyance from contact with radiated heat, escaping carbonic oxide, or the combustion products from the generator, the contrary being the case in the Munich furnace.

To clearly comprehend the Munich results given in your JOURNAL it is necessary to understand that Saar coal (which was worked in the Munich reported tests) is very easily carbonized. That coal would require the aid of but from 7 to 9 per cent. of fuel when carbonizing by the Klönne plan; also Bohemian coal, which requires the use of 6 to 8 per cent. of fuel. On the other hand, Westphalian coal takes up about 14 per cent., and the Silesian variety absorbs from 12 to 13 per cent. of fuel. In consequence the Munich figures are, in a certain sense, misleading.

In the matter of the illuminating powers of the gases made under the two systems, the Klönne special arrangement for passing the gases from the mouthpieces at a moderate temperature yields an increase of at least two candles over that afforded by any other furnace systems. In estimating the durability of the furnaces one must not only regard the quantity but also the quality of the coal carbonized; for from the figures above given, 2,000 days' working on Saar coal will not be equal to 1,000 days with the Westphalia variety. The English *Journal of Gas Lighting* (June 22, 1886, p. 1196) states that certain Klönne furnaces, after 731 days' working, were, upon careful examination, found to be as good as when first started; further, that the entire extra cost of the Klönne construction had, by reason of the extra saving in fuel secured, been completely neutralized in the first 271 days of working. In fact experience has proved beyond doubt that, in the hands of a practical gas maker, the Klönne furnaces present no difficulties whatever. At the Hanover works (owned by the Imperial Continental Company) the Klönne furnaces, carbonizing Westphalian coal, had been operated for 1,100 days without any need for repairs. I believe that between 15 and 20 thousand retorts are now working under the Klönne plan in Europe and America, the most notable instances in your country being at Newark, Philadelphia, Milwaukee and Chicago.

The Klönne hydraulic-main-washer-condenser, intended to prevent stoppages in ascension pipes, and the deposit of pitch in the hydraulic main, was described in the issue of your JOURNAL, dated Nov. 2, 1886. In this letter I state facts and actual results obtained by me in the practice of my profession.

Yours truly,
W. KLEIN.

The Market for Gas Securities.

The city gas share market may be written down as dull and strong. Consolidated sold up to 85; Equitable ranged between 125 and 130; and Mutual ruled strong at 103 to 105. The financial agents of the proposed Standard Gas Light Company report a fair inquiry for their specialty; but, even at best, this security seems to hang fire. In Brooklyn shares a firmer feeling prevails. The Brooklyn Citizens Company will, on May 1st, retire the present issue of 10-20 seven per cent. sinking fund bonds, and substitute therefor an equal amount of fives, redeemable at option of Company on six months' notice. That substitution will hardly meet with favor on the part of the original holders. The Brooklyn situation, in the matter of gas legislation, is still badly mixed, but must soon be decided one way or the other. Holders do not seem greatly disturbed at the prospect. The Baltimore situation is further entangled by the Equitable reduction to 35 cents per thousand, but insiders predict that now is the time to buy Baltimore gas shares. Talking of "legitimately" cheap gas reminds us that the Dayton (Ohio) Company will, from 1st inst., institute a net rate of \$1.15 per thousand. No new developments in the Chicago transfer.

SITUATION WANTED

By a Practical Gas Engineer.

For 18 years in charge of very successful operations of a coal gas works. Best of references given. Address

"F. B.," care this Journal.

SUPERINTENDENT'S POSITION DESIRED.

By a practical gasfitter and competent bookkeeper, who has had entire management of coal and water gas plants. Satisfactory references furnished. Address

665-3 "B.," care this Office.

Superintendent's Position Desired

By a practical man of twenty-five years' experience in the manufacture and distribution of coal and water gas. Satisfactory references given. Address

646-11 "ENGINEER," care this Office.

FOR SALE,

BY THE MEMPHIS GAS LIGHT COMPANY, MEMPHIS, TENN.

8 Sets Oval Mouthpieces, for 13x16 in. retorts, 4 in. stand pipes and bridge pipes. 4 Pieces Hydraulic Main, two of them 21 ft. long, 10x10 in., and the other two 8 ft. long, 10x10 in. 10 Retorts, 13x16 in., 8 ft. long. 1 Cameron Exhauster, complete and in order, with 8 in. connections. 1 Tubular Washer, 4 ft. diam. and 8 ft. high. 3 Air Condensers, 3 ft. diam. and 10 ft. high. 4 Purifier, 10x14 ft., and 3 ft. deep. 1 Dry Center Seal, complete and in order, with 10 in. connections.

C. W. HUNT CO.,

No. 111 Broadway, N. Y. City.

MANUFACTURERS OF

Coal Handling Machinery,

AUTOMATIC RAILWAY, HOISTING ELEVATOR, CABLE RAILWAY, STEAM SHOVEL, HOISTING ENGINES, COAL TUBS, COAL & COKE CARS.

Plans and Specifications made for the

Erection of Coal Storage Buildings

Send for a Descriptive Pamphlet.

FOR SALE,

Ten No. 2 Siemens Regenerative Gas Lamps, With Factory Fixtures and Reflectors complete and in order. Only used three or four months. Will be sold cheap. DANVILLE NAIL AND MFG. CO., Danville, Pa.

JARVIS ENGINEERING CO.,

61 Oliver St., Boston, Mass.

CONTRACTORS FOR ERECTING

COMPLETE STEAM OUTFITS FOR ELECTRIC LIGHTING STATIONS.

Steel Boilers set with Jarvis Pat. Boiler Setting,

To burn COKE SCREENINGS for Fuel.

ARMINGTON & SIMS CO. ENGINES,

Belted direct to Dynamos, without using Shafting.

SEND FOR CIRCULARS.

REFERENCES.—Charlestown Gas & Electric Light Co., Charlestown, Mass.; Schenectady Gas & Electric Light Co., Schenectady, N. Y.; Brookline Gas Co., Brookline, Mass.

SUPERINTENDENT'S POSITION WANTED

By a practical manager of coal and oil gas works, of 22 years graduation in all the departments—viz., distribution, manufacture, and secretary's duties. Also has a partial knowledge of electric lighting. Satisfactory references given. Address 656-11 R. HORTON, care this Office.

Improved Patent GAS BAG OR BLADDER VALVE.

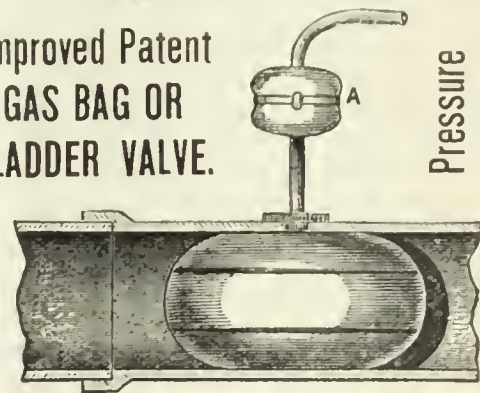

Pressure Indicator.

MANUFACTURED BY

PEERLESS MFG. CO., 34 Murray St., N.Y.



CHAPMAN VALVE MANUFACTURING CO.,

MANUFACTURERS OF

Valves and Gates for Gas, Ammonia, Water, Etc.

Also, Gates and Fire Hydrants With and Without Independent Nozzle Valve. All Work Guaranteed.

WORKS & GEN'L OFFICE:

Indian Orchard, Mass.

TREASURER'S OFFICE:

72 Kilby & 112 Milk Sts, Boston, Mass.

MILLS' REVERSIBLE LIME TRAY,

AND

WOODWORK

Of Every Description

NEEDED BY GAS WORKS.

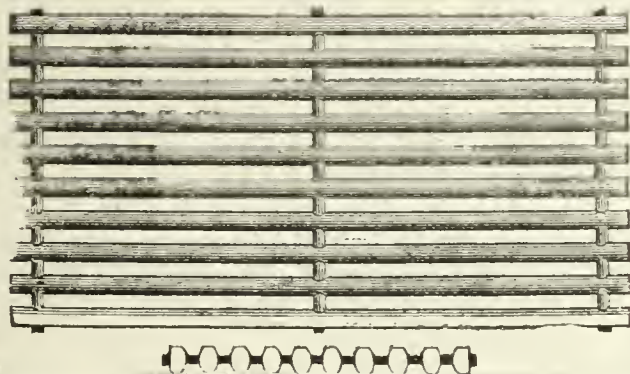

SEND FOR CIRCULAR AND PRICE LIST TO

GEORGE A. MILLS,

Canton Av. & President St., Baltimore, Md.

STEPHEN A. MORSE, President. GODFREY REBMANN, Vice-Pres.

M. B. DYOTT, Superintendent.

EDWIN F. MORSE, Secretary. CARLTON M. WILLIAMS, Treas.

STANDARD GAS LAMP CO.,

Office, 411 Cherry St. Factory, 1101, 1103 & 1105 Frankford Av.

Philadelphia, Pa.



It is to the interest of Gas Companies and Cities to use Dyott's Patent Champion Lamps, which give double the light with the same consumption of gas, and will save 50 per cent. over others in cost of keeping in repair. Gas Companies and others intending to erect Lamps of any description will do well to communicate with us. Special Drawings furnished and Estimates given on application upon Architects', Engineers' or our Draughtsmen's Plans.

Our Patent System of Instantaneously Lighting Gas (without electricity) for R. R. Depots is unequaled. Our High Candle Power Burner is superior to the Electric Light or any other High Candle Burner. We manufacture every description of Ornamental Lamps.

WONDERFUL GAS LIGHT!

Great improvements! New inventions! Brilliant success! Brilliant light! Over 500,000 of the Gas Lamps and Burners designed by GEO. H. GREGORY now in practical use. Send for Catalogue. Prices reduced on all goods in order that Gas Companies will introduce the goods to the consumer at a reasonable price. Over one hundred Gas Companies are selling the new lamps and burners. The only way to prevent the adoption of incandescent electric light is to put on the wonderful gas lamps and burners. Address GEO. H. GREGORY, Gas Lamp and Burner Mnfr., 389 BROADWAY, N. Y.

To All Whom It May Concern!

The SIEMENS-LUNGREN COMPANY hereby warns the public against the use of various infringing Regenerative Gas Lamps which are offered for sale. This Company has heretofore delayed bringing suit to enjoin the manufacture or importation of such infringing lamps, solely because of the practical worthlessness of the infringing devices; and although, in each instance, they infringe some one or more of the various patents owned or controlled by this Company, they have fallen into disuse sooner than any suit could be brought to a hearing. As, however, the introduction of these infringing lamps has tended to discredit the practicability of our Company's system of regenerative gas lighting, we have instructed our Attorneys, Messrs. Geo. Harding, C. S. Whitman, and Silas W. Pettit, to give notice that legal proceedings will in future be taken against all such infringers.

THE SIEMENS-LUNGREN CO., 21st St. & Washington Av., Phila., Pa.

ALBO-CARBON FIXTURES FOR SALE.

Three 12-Burner, Two 8-Burner, and Fourteen 6-Burner Clusters.

All in good order, having been used but six months. Will be sold cheap. For particulars communicate with

E. G. PRATT, Supt. N. Attleboro Gas Lt. Co.,
North Attleboro Mass.

FOR SALE,

Two Sinuous Friction Condensers

Each 1 ft. 3 in. wide by 11 ft. 3 in. long, and 18 ft high, of sufficient capacity for 225,000 cu. ft. per day. Apply to
665-12 PETER COFFEY, Supt Gas Co., Peoria, Ill.

GAS WORKS FOR SALE.

A RARE CHANCE.

The owner will dispose of the controlling interest in a gas works in a growing Western city, on account of declining health and inability to attend to the business. For particulars address
665-6 P. O. Box 825, Appleton, Wis.

MITCHELL, VANCE & CO.,

MANUFACTURERS OF

Chandeliers

and every description of

GAS FIXTURES.

Also manufacturers of Fine Gilt Bronzes and Marble Clocks, warranted best time-keepers. Mantel Ornaments, etc.

Salesrooms, 836 Broadway, N. Y.

Special Designs furnished for Gas Fixtures for Churches, Public Halls, Lodges, etc.

Ferric Oxide for Gas Purification.

Ferric Oxide, as ground, screened, and prepared by me for purifying purposes, has now been in use for several years by many of the gas works throughout the country, including Detroit, Chicago, Milwaukee, East Saginaw, Burlington (Iowa), Ann Arbor, etc. It has proved, as I believe, the **Most Effective and Economical Agent** now in use. I am prepared to furnish the Oxide by the 100 lbs. or in car load lots, and will be pleased to give price f.o.b. cars at Ann Arbor or at place of destination. Address

S. H. DOUGLAS, Prest. Ann Arbor (Mich.) Gas Light Co.

THE KERR MURRAY MANUFACTURING COMPANY, Fort Wayne, Ind.

CONSTRUCTING ENGINEERS AND BUILDERS OF

GAS WORKS AND HOLDERS.

Drawings, Estimates, and Specifications Furnished for the Construction of New and the Rebuilding of Old Works.

MANUFACTURERS OF LATEST IMPROVED APPARATUS FOR COMPLETE AND AUXILIARY OIL AND WATER GAS PLANTS.

Rotary and Steam Jet Exhausters, Rotary Washers, Self-Sealing Mouthpieces,

HYDRAULIC LIFTS FOR PURIFIER COVERS.

"VALVE COMBINATION" FOR OPERATING ONE TO FOUR OR MORE PURIFIERS.

Street Specials, Valves, and Fittings.

COKE CRUSHERS, COAL AND COKE WAGONS, LAMP POSTS.

Iron Roofs, Cutters, and Retort House Floors.

STEAM ENGINES AND BOILERS, IRON COAL SHEDS.

Single and Telescopic Gasholders.

Correspondence is Respectfully Solicited.

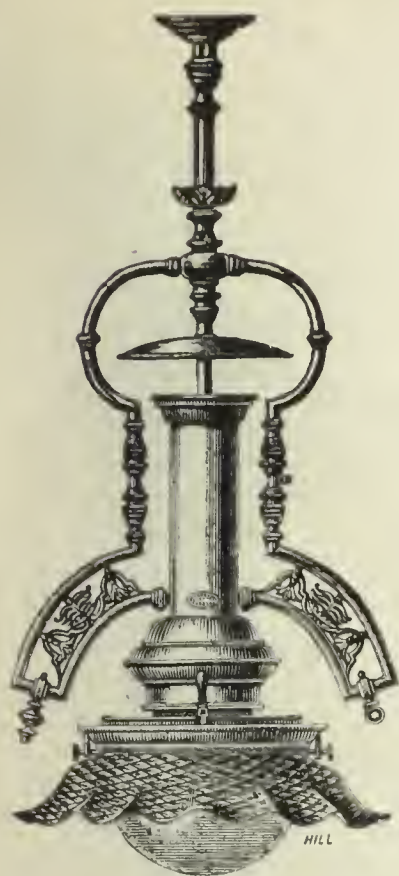

A NEW SYSTEM OF BURNING GAS, BY WHICH
ITS ILLUMINATING POWER IS MORE THAN
TREBLE THAT OBTAINED BY
ORDINARY METHODS.

To the Wenham Patent Lamp was awarded the Medal of the Sanitary Institute of Great Britain, 1884; Gold Medal of the International Inventors' Exhibition, 1885; also, the Highest Award at the Edinburgh Exhibition, 1886.

We now have on exhibition the largest display of Gas Lamps ever offered in this country, adapted to Stores, Halls, Banks, Dining and Drawing Rooms, Libraries, Billiard Rooms, etc.

The **WENHAM LAMP** is the **PERFECTION OF GAS LIGHTING!**

DR. WALLACE, Gas Examiner to the City of Glasgow, after an exhaustive test of this Lamp in comparison with others, remarks:

"The results from the Wenham Lamp largely exceed any that I have previously obtained from lamps constituted on the regenerative principle, and are enormously in advance of those obtained with any Gas Burner of ordinary construction."

This statement is fully corroborated by leading Gas Engineers, Managers

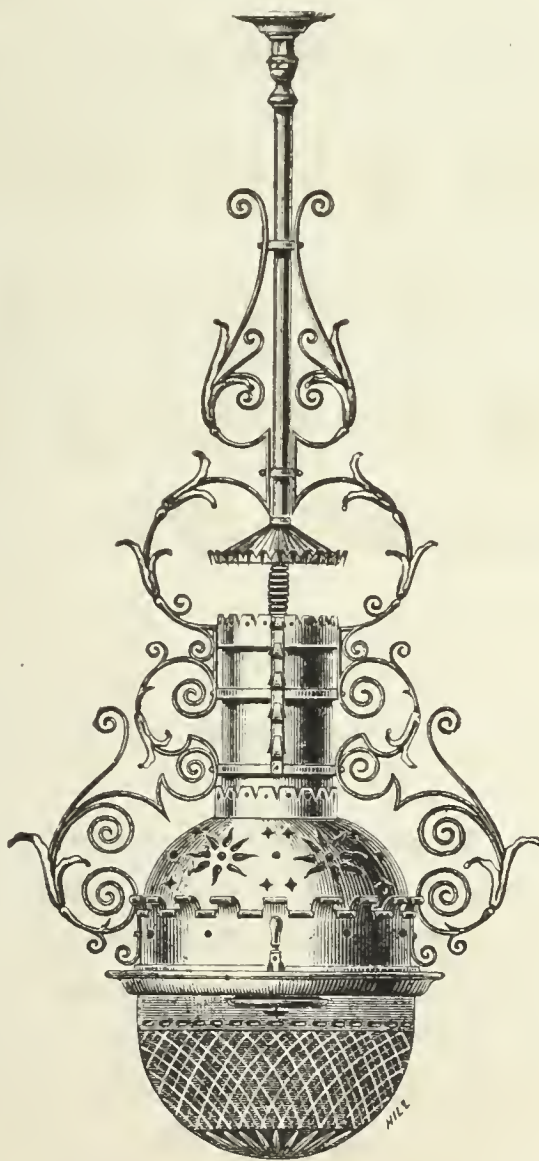

of Gas Works, and large Consumers throughout the Continent, whose testimonials we have.

The advantages of the Wenham Lamp are—

IMMENSE ECONOMY IN THE CONSUMPTION OF GAS;

intensity, purity, softness, and steadiness of light; absence of downward shadow; security against fire (recommended by insurance companies for safety); and the most important auxiliary that Gas has yet secured to meet successfully, at a large reduction in cost, the use of Electricity as a popular illuminant.

We will be pleased to communicate with responsible parties desiring to secure exclusive territory for the sale of our Lamps.

THE U. S. WENHAM PATENT GAS LAMP CO.,

SHELDON MFG. CO., General Agents, 18 W. 23d St., N. Y. City.

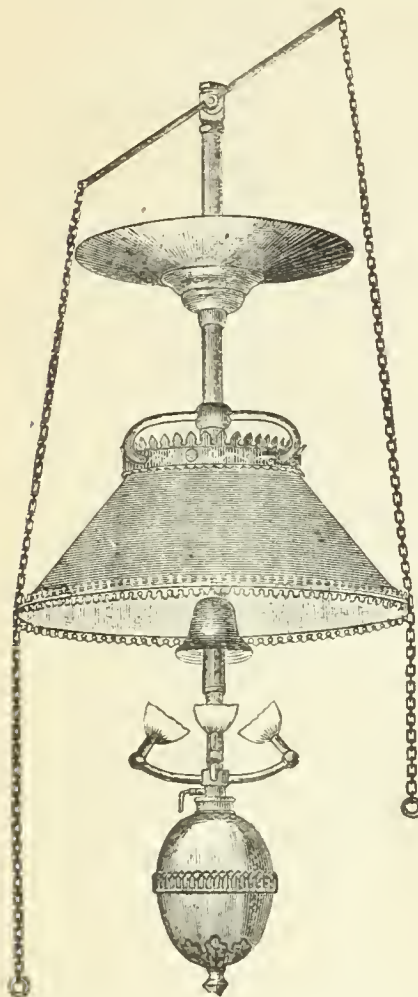

THE ALBO-CARBON LIGHT!

The Perfection of Gas Lighting.

Producing the Highest Illumination yet obtained from Gas, and
EFFECTING A SAVING IN ITS CONSUMPTION.

It has been most effective in

Replacing Electricity,

AFFORDING A

SOFT WHITE LIGHT
of **EXTREME BRILLIANCY & POWER.**

It has been most successful in

Supplanting Kerosene,

Giving Increased Light, Less Heat, and Perfect Safety
WITHOUT ADDITIONAL COST.

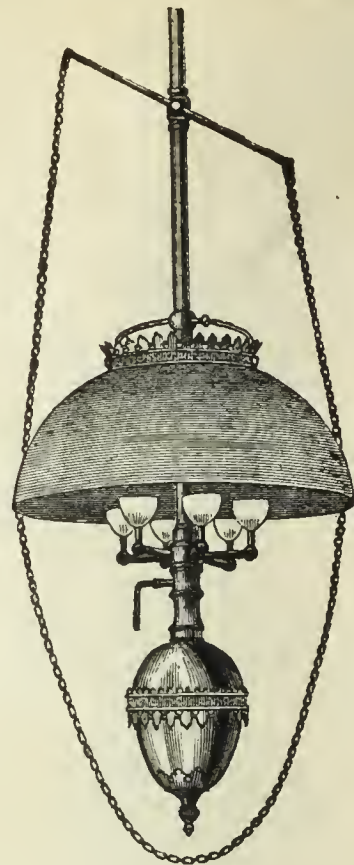

NOTICE.—Suits are pending in the United States Circuit Courts in Illinois and Pennsylvania against various parties for infringement of our Letters Patent No. 247,925, dated October 4, 1881, and No. 333,862, dated January 5, 1886. The first of these suits has come up for hearing, and an injunction has been granted therein. The second of said suits has not yet been reached for hearing. All persons are cautioned against manufacturing, selling, or using any apparatus or material which infringes our Patents. We intend to prosecute all parties infringing patents owned by us.

THE ALBO-CARBON LIGHT COMPANY, - - - NEWARK, N. J.
Sole Manufacturers for the United States.

DURING THE PAST YEAR, THE

NATIONAL GAS LIGHT AND FUEL CO.

218 LA SALLE ST., CHICAGO,

Have Erected Twelve Sets of Water Gas Generating Apparatus under the
Springer Cupola System. They are as follows:

Newton Illuminating Company, Newton, Kansas.—Daily capacity, 120,000 cu. ft.

Wellington Light & Heat Co., Wellington, Kansas.—Daily capacity, 120,000 cu. ft.

Chippewa Falls, Gas Light Co., Chippewa Falls, Wis.—Daily capacity, 120,000 cu. ft.

Elkhart Gas Light & Coke Co., Elkhart, Indiana.—Daily capacity, 120,000 cu. ft.

Madison City Gas Light Company, Madison, Wis.—Daily capacity, 120,000 cu. ft.

South Bend Gas Light Co., South Bend, Indiana.—Daily capacity, 250,000 cu. ft.

Sheboygan National Gas Comp'y, Sheboygan, Wis.—Daily capacity, 120,000 cu. ft.

Salina Gas Light Company, Salina, Kansas.—Daily capacity, 120,000 cu. ft.

Rathbun Company, Deseronto, Province Ontario.—Daily capacity, 80,000 cu. ft.

Jefferson City Gas Light Co., Jefferson City, Mo.—Daily capacity, 120,000 cu. ft.

Mankato Gas Light Company, Mankato, Minnesota.—Daily capacity, 80,000 cu. ft.

Minneapolis Gas Lt. & Coke Co., Minneapolis, Minn.—Daily capacity, 1,000,000 cu. ft.

1886

1886

Kloenne & Bredel Improved REGENERATIVE FURNACES

Self-Sealing Mouthpieces and Bridge Pipes,
RETORT HOUSES, WASHER-SCRUBBERS
GASHOLDERS, AND GAS WORKS COMPLETE.

Our system of heating retorts by regenerative furnaces is the simplest, most economical, most durable, and cheapest of any in use. It is the only regenerative furnace used to any extent in Great Britain, where several thousand retorts are working at the present time. In Birmingham alone 952 retorts were erected, and they are giving the best satisfaction ever obtained from any regenerative furnaces. The great advantages our benches have over all others are the following:

The generator and regenerator are independent of each other, so that any contraction or expansion of one will not interfere with the other.

The superheating surface is greater than in any other furnace yet constructed. The regenerator is absolutely self-tightening, and cannot get out of order.

The thickness of material between the waste gases, secondary and primary air is only 1½ inches, which increases the regenerative power from 100 to 500 per cent.

The generator is working absolutely cold, and therefore is not liable to any perceptible wear and tear.

The grate, having an enormous surface, allows the use of an inferior fuel, such as breeze, fine coke, or slack coal.

Clinkers are never formed. By an ingenious arrangement of mixing air and the steam produced by the cooling water all incombustible materials in the fuel are formed into soft ashes.

The waste gases go up through flues at 400° to

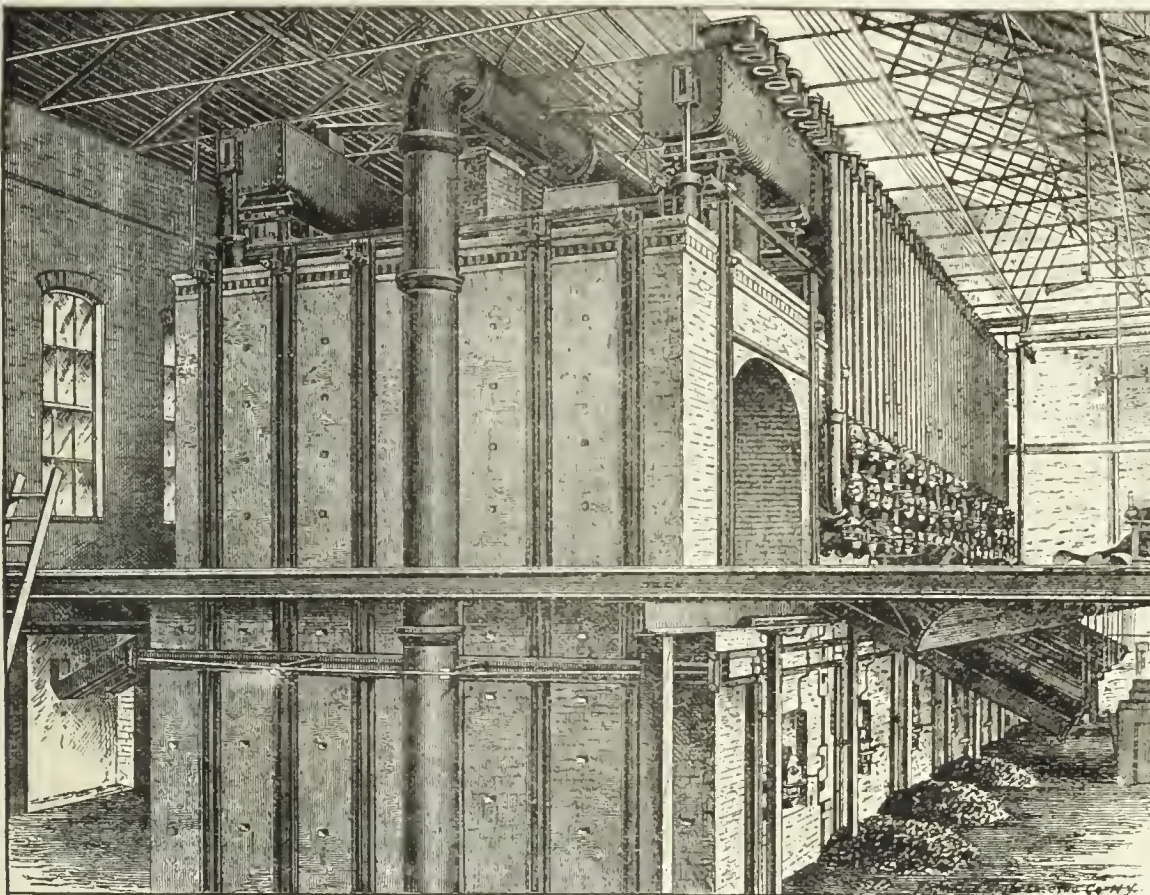

500° F. No large chimneys are required.

No cold air can enter; consequently no cracking of retorts.

The generator is inside of bench, thereby preventing any loss of heat; and stokers do not have to stand on a hot floor, as is the case where the generator projects outside of the bench.

In the past two years more than 500 retorts, with a capacity of five million cubic feet of gas per diem, have been erected in this country, and these are giving the best satisfaction, as the following testimonials will show.

We also construct h.f. regenerative benches, which will give the best results, and can be built in existing skeleton arches.

OFFICE OF THE NEWARK GAS LIGHT COMPANY, NEWARK, N. J., January 28, 1887.

MR. FREDERICK BREDEL, General Agent Kloenne Regenerative Furnace:

Dear Sir—The Kloenne Furnaces erected by you have been in continuous use for more than a year, and continue to give us satisfactory results. We are carbonizing 1,800 pounds coal per retort in 24 hours, and the average fuel consumption for this much has been 16.8 pounds by volume of the coke produced, or 100 pounds coal have been carbonized by 11.25 pounds hot coke. We have not lost a retort yet, and I think that those in use will give us six months' more service.

Very truly, [Signed] EUGENE VANDERPOOL.

ENGINEER'S OFFICE, MILWAUKEE GAS LIGHT COMPANY, MILWAUKEE, WIS., January 26, 1887.

FRED. BREDEL, C.E.: Dear Sir—Upon your request for a testimonial for publication, I am pleased to send you the following, as I consider it deserved for the way in which your contract was carried out with us. I would say to any in the profession that among all the plans of benches presented to me from which to select I chose the "Kloenne" for several reasons. I considered it perfect in principle, that at all times it would be under absolute control, and also that each block in the regeneration could be easily seen and repaired if necessary. Your work upon our benches was done as good as it possibly could have been by anyone, and such has been the opinion of the several visitors during the progress of the work and since its completion, without exception. We have been running the furnaces since Oct. 6, and as yet have observed no cracked or sagged retorts. Every part of the work appears as perfect as when set. Although the first month was used up in experimenting and learning how to run the furnaces, and since that time we have experienced very cold weather, yet we are selling 26 bushels of coke (40 lbs. per bushel) per net ton of coal used. The consumption of coke in the furnaces does not exceed 20 per cent. at the present season, and for the year I am sure will be materially less.

Yours truly, [Signed] E. G. COWDERY.

OFFICE OF THE CHICAGO GAS LIGHT AND COKE COMPANY, CHICAGO, ILL., January 27, 1887.

FRED. BREDEL, Esq.: Dear Sir—We have had eight benches of nines with the Kloenne furnaces running continuously for 13 months. The results have averaged 9,000 cubic feet per mouthpiece in 24 hours, with a fuel consumption of 13 pounds coke per 100 pounds coal carbonized.

Yours truly, [Signed] THEOB'D FORSTALL, V.-P.

For further information apply to

FRED. BREDEL,
332 East 17th Street, N. Y. City. } OR { **G. F. KREISCHER,**
132 Mangin Street, N. Y. City.

GAS ENGINES.

GAS WORKS APPARATUS AND CONSTRUCTION.

THE CLERK GAS ENGINE CO.,

Main Office, 1012, 1014, 1016, 1018 Filbert St., Philadelphia, Pa.

WM. W. GOODWIN, Prest.

E. STEIN, Sec.

S. LEWIS JONES, Asst. Sec.

A. J. DOTY, Supt.

The utility and convenience of the Gas Engine being no longer an open question, it only remains now for intending purchasers to select the BEST. We claim for the CLERK GAS ENGINE that it is equal to any other manufactured as regards steadiness in running, simplicity, and ease of keeping in repair, and that it gives the greatest amount of power for the least money (both in first cost and expense of running) of any engine made. In support of this claim we refer to the test of the Gas Engines made under the direction of the American Institute of New York, in December, 1885, and heretofore published in these columns. These engines are especially adapted for continuous running under heavy loads, and we can refer to Engines which have run 22 hours a day for months at a time.

Made in Sizes of 5, 10, 15, 20, and 25 Horse Power. All Engines Guaranteed for One Year.

"RUSTLESS" IRON WATER PIPE.

RUSTLESS

Send for New Catalogue.

RUSTLESS

The **WELLS RUSTLESS IRON COMPANY,**
Nos. 7 and 9 Cliff Street, New York City.

GASHOLDER TANK CONSTRUCTION, ETC.

Gas Companies and others about to erect Gasholders will find it profitable to consult W. C. WHYTE, who for over thirty years has made a speciality of

Holder Tank Excavation and Mason Work.

Fifty tanks now in operation show the sort of work done. Address

W. C. WHYTE, No. 15 Cortlandt St., N. Y. City.

GAS vs. ELECTRIC LIGHT.

We would invite attention to the able and exhaustive argument of General A. Hickenlooper, President of the Cincinnati Gas Light and Coke Company, contained in a handsome pamphlet of 96 pages, entitled

"EDISON'S INCANDESCENT ELECTRIC LIGHTS FOR STREET ILLUMINATION. REPORT OF AN ARGUMENT DELIVERED BY A. HICKENLOOPER BEFORE THE COMMITTEE ON LIGHT, MUNICIPAL COUNCIL, CITY OF CINCINNATI, JULY 22, 1886."

This is a subject of special interest to all Gas Light Companies.

Prices.

25 copies.....	\$7.50	100 copies.....	\$22.50
50 copies.....	12.50	250 copies.....	50.00

A sample copy will be sent by mail on receipt of 50 cts.
A. M. CALLENDER, & CO., 42 PINE ST., N. Y. CITY.

F. J. DAVIS & J. R. FARNUM,

TRUSTEES AND AGENTS FOR THE

SINUOUS FRICTION CONDENSER.

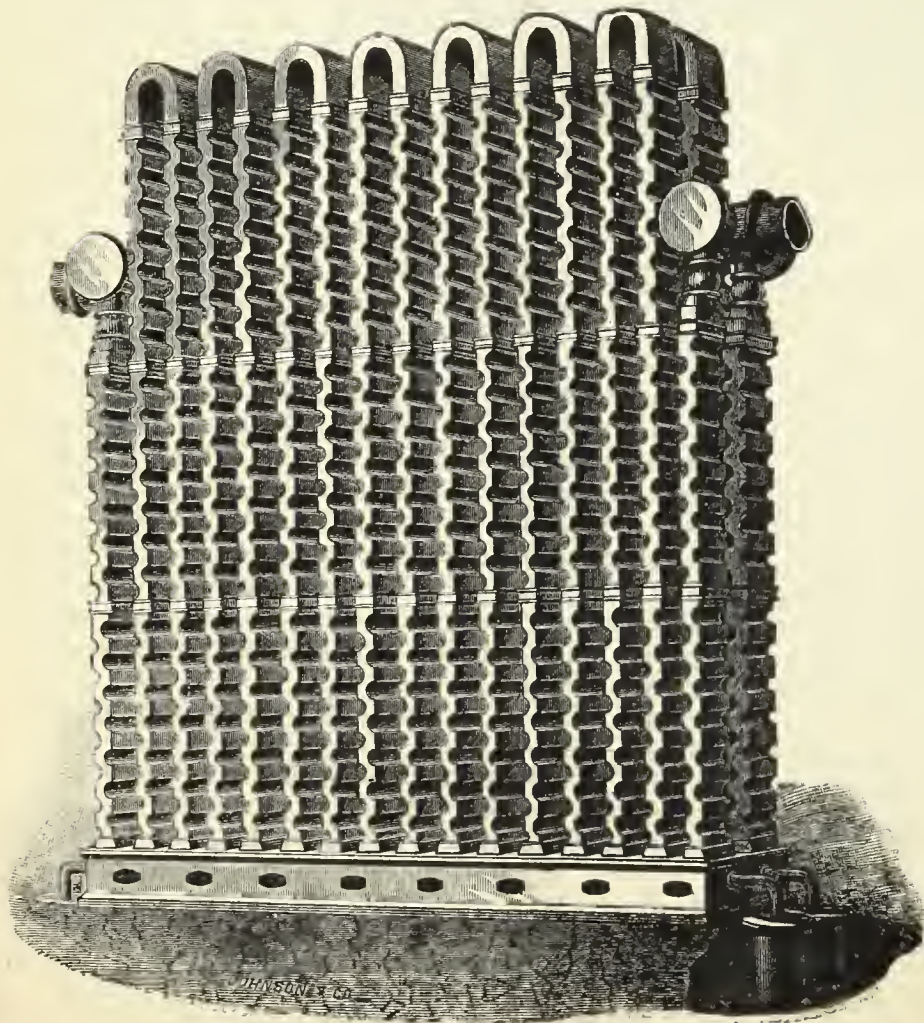

We desire to draw the attention of the gas community to the merits of the SINUOUS FRICTION CONDENSER. Companies intending to introduce new condensers into their works will do well to confer with us and examine plans and estimates before contracting for any other pattern. The FRICTION CONDENSER is now in use at the gas works located in the following places:

Portland, Me.	Brookline, Mass.	Pawtucket, R. I.	Frederickton, N. B.
Newport, R. I.	Chelsea, Mass.	Jamaica Plain, Mass.	St. John, N. B.
Gloucester, Mass.	Woburn, Mass.	Attleboro, Mass.	Paterson, N. J.
Newton & Water- town, Mass.	Peoria, Ill.	Calais, Me.	Dover, N. H.
	Clinton, Mass.	Fall River, Mass.	Waltham, Mass.
		Nassau Works, Brooklyn, N. Y.	

DAVIS & FARNUM MFG. CO.

MANUFACTURERS OF

Gas and Water Pipes,

AND

GAS AND WATER MACHINERY

OF THE MOST APPROVED PATTERN.

Also, Gasholders and Iron Roofing.

Orders from Gas and Water Companies promptly attended to.

WALTHAM, MASS.

Boston Office, Room 55, Mason Building, 70 Kilby Street.

GAS EXHAUSTERS

Have long been regarded as "luxuries" not to be thought of by small companies; but

CONNELLY'S JET EXHAUSTER IS WITHIN THE REACH OF ALL!

Will Pay for Itself in Six Months! Saves Labor! Lengthens the Lives of Retorts! Prevents the Formation of Carbon!
Increases the Yield from Twelve to Fifteen Per Cent.!

We find, after careful inquiry and investigation, that the majority of the Gas Works in the United States and Canada are running *without Exhausters*, which, in our opinion is due to two causes. *First.* The prices heretofore asked for Exhausters have been so high as to counteract, to a great extent, the advantages to be obtained from their use, and caused most managers to postpone their adoption indefinitely, or until their consumption had largely increased. *Second.* Many superintendents have a false impression that it will not pay to run an Exhauster in works producing less than 20,000 feet per day.

The first difficulty we overcome by selling our Exhausters at *extremely low prices*, as will readily be admitted after comparing our list with those of other manufacturers; and as to the second, we can say we have most convincing evidence from many companies operating our Exhausters that they can be used to advantage in works producing *as low as 6,000 cubic feet per day*.

In our improved Exhauster we combine the "Exhaust Tube" Gas and Steam Governors, Gas Compensator, and Bye-Pass Valves in the most compact form possible, which is a very great advantage to the machine, besides enabling us to manufacture and sell at the low prices given.

This is the only Exhauster in the market having a "compensator" in addition to the "gas governor"—a most important improvement, as it does away with all possible danger of their ever drawing air, and thus reducing the illuminating power of the gas.

FOR OIL GAS WORKS.

Our Exhausters are especially adapted for the use of Oil Gas Works; and where oil is required to dilute the gas a valve can be adjusted *to take the exact amount of air required*, thus dispensing with air pumps and their attendant labor and annoyance.

POINTS OF SUPERIORITY.

Requires *one-half the floor space and one-third less steam* than any other Exhauster in the market of same capacity. *More cheaply and easily connected*, as outside "Bye-Pass Valves" are dispensed with. It is the only Exhauster manufactured having "Compensator" and "Governor" *combined*, the "Compensator" with all other Exhausters being a separate and distinct machine. It is simple in construction, easily adjusted, not liable to get out of order, and *can be operated by ordinary workmen*.

NAPHTHALINE AND STEAM JET EXHAUSTERS.

As many superintendents of Gas Works believe the use of a Steam Jet Exhauster will inevitably cause trouble from *naphthaline* deposits, we recently sent out letters of inquiry to superintendents using our Steam Jet, asking for their experience, and the following replies speak for themselves. That naphthaline deposits are often unjustly attributed to Jet Exhausters is well known by many superintendents. When the cause cannot be determined it seems to be the rule to place the responsibility on the Jet Exhauster, *if they have one*; but if no Exhauster is used *the cause remains a mystery*.

OFFICE LISTOWEL GAS LT. CO., LISTOWEL, CAN., May 29, 1885.
Messrs. Connelly & Co., Ltd.: Gentlemen—The Exhauster purchased from you over three years ago, and now in use, has proven in every way all you claim for it, and has given us great satisfaction. No trouble has arisen from naphthaline.
Yours respectfully, F. W. HAY, Sec.

RICHMOND GAS CO., RICHMOND, KY., June 1, 1885.
Messrs. Connelly & Co., Ltd., 407 Broadway, N. Y.: Gentlemen—I put in your Steam Jet Exhauster last November. I think it a perfect machine, as it requires no attention whatever. Have not had any naphthaline to contend with; it would be very easy to get rid of that substance if I had it.
Yours very truly, J. B. GORDON, Supt.

HAMPTON, VA., June 3, 1885.
Messrs. Connelly & Co., Ltd.: Gents—We have been using your Steam Jet Exhauster for the past 3 years, and have never had any trouble with it whatever, either from naphthaline or any other source.
Yours truly, J. B. H. GOFF.

BRUNSWICK, ME., May 27, 1885.
Messrs. Connelly & Co., Ltd.: Dear Sirs—Your favor of 23d inst. at hand. In answer would say your Exhauster works well with us. We make an oil gas; are not troubled with naphthaline. Very truly yours, B. G. DENNISON, Prest. Brunswick Gas Lt. Co.

WILMINGTON, O., June 15, 1885.
Messrs. Connelly & Co., Ltd.: Dear Sirs—We started your make of six-inch Steam Jet Exhauster March 30, and I am pleased to state, from the time the steam was turned on, it has performed its work to our entire satisfaction. We have never had any other but a Steam Jet Exhauster, and have never been troubled with naphthaline. For many reasons I prefer it to the "rotary," and have no hesitancy in recommending it.
Yours truly, E. W. HAMLIN, Sec. Gas Co.

OFFICE LOGAN GAS LT. & COKE CO., LAGAN, HOCKING CO., O., May 29, 1885.
Connelly & Co., Ltd.: Gentlemen—In answer to yours of 27th we have to say that the Steam Jet Exhauster put in for us by you last fall has been used constantly since, and, up to this time, we have had no trouble with naphthaline. We have heard many gas men say that a Steam Jet Exhauster is liable to bring on trouble with naphthaline, and we have had that fear before us; but so far we have escaped, and we trust we may not have any experience with that gas manager's bugbear.
Yours truly,
LOGAN GAS LT. & COKE CO.

OFFICE ATHENS GAS LT. CO., ATHENS, O., May 30, 1885.
Messrs. Connelly & Co., Ltd.: Dear Sirs—We take pleasure in giving you an unqualified endorsement of your Steam Jet Exhauster. It has been in place almost a year; been tested in all seasons and under all conditions; it has always proved true to the work assigned it. We have had no naphthaline deposit, nor any trouble chargeable to the Exhauster. Nothing but good has come from it, and *great good* at that. We can't do without it.
Very truly yours, C. H. WELCH, Supt.

OFFICE MEADVILLE GAS WORKS, MEADVILLE, PA., May 29, 1885.
Connelly & Co., Ltd.: Gents—Yours of the 27th received and contents noted. Would say that after using your Steam Jet Exhauster for the past 18 months, find it perfectly satisfactory in every way. So far as naphthaline is concerned, we have had no trouble whatever as yet.
Yours, GEO. S. CULLUM, Supt.

NYACK AND WARREN GAS LT. CO., NYACK, N. Y., May 25, 1885.
Connelly & Co., Ltd.: Gentlemen—Since your Jet Exhauster has been here there has been no trouble, and certainly *no naphthaline*. The only trouble I have experienced was the Jet becoming clogged with tar last week, and I cleaned it in a few minutes. It has run over three years without any trouble or cost for repairs.
Yours truly, A. MURRAY, Lessee and Manager.

OFFICE CADIZ GAS LT. CO., CADIZ, O., May 29, 1885.
Messrs. Connelly & Co., Ltd.: Gentlemen—Yours of 23d, inquiring how our Steam Jet Exhauster is doing, has been received. We have been using one of your Exhausters about four years, and with the best of satisfaction. We have less trouble with carbon in retorts, make more gas from same amount of coal than before, and have no trouble with stoppage in pipes or trouble from tar; and as regards naphthaline, we are not troubled with it, and do not know what it is to have any stoppage in pipes from naphthaline.
Very truly yours, A. N. HAMMOND, Sec.

SIDNEY (OHIO) GAS WORKS, June 1, 1885.
Connelly & Co., Ltd.: Gentlemen—We have now been using one of your Steam Jet Exhausters about five months, and thus far it has given us perfect satisfaction. We get a better yield and a more brilliant quality of gas from the coal. We have seen in papers and heard from different individuals that Steam Jet Exhausters were productive of naphthaline. "We can't see it," as we have found no trace of it in the works, mains, services, or meters.
Respectfully yours, W. W. GRADHAM, Supt.

CONNELLY & CO., LTD., No. 177 Broadway, New York City.

**T. C. HOPPER'S
AUTOMATIC DIFFERENTIAL GAS GOVERNOR**

Is now in Practical Operation, doing Perfect Automatic Service with Great Precision.

This Governor will do all and more than any other Governor on the Market.

BE SURE TO THOROUGHLY INVESTIGATE THE SUPERIOR MERITS OF THIS GOVERNOR BEFORE PURCHASING.

For Simplicity and Reliable Work it has no Equal. Correspondence Solicited.

T. C. HOPPER & CO., - - Manufactory, 2227 Wood Street, Phila, Pa.

LUDLOW VALVE MFG. CO.

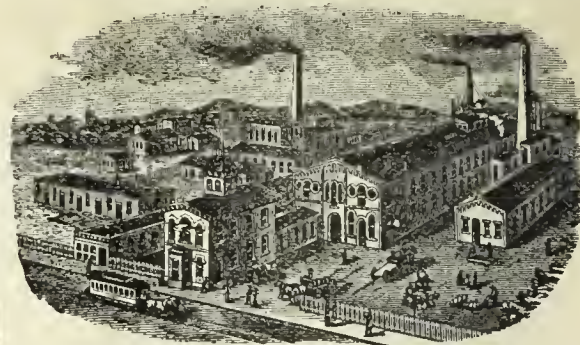

OFFICE AND WORKS,
938 to 954 River Street and 67 to 83 Vail Av.
TROY, N. Y.

Hydraulic Main Dip Regulators, also
Check Valves, Foot Valves, Yard-
wash and Fire Hydrants.
Send for Circulars.

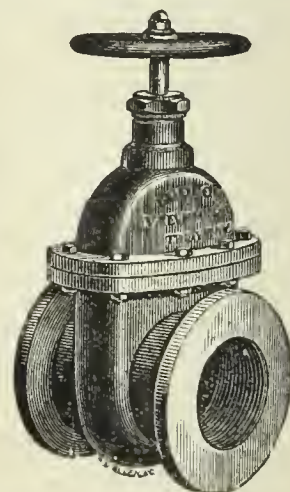

Valves.—Double and Single Gate, 1/2 in. to
48 in., outside and inside Screws. Indica-
tor, etc., for Gas, Water, Steam, and Oil.
Send for Circulars.

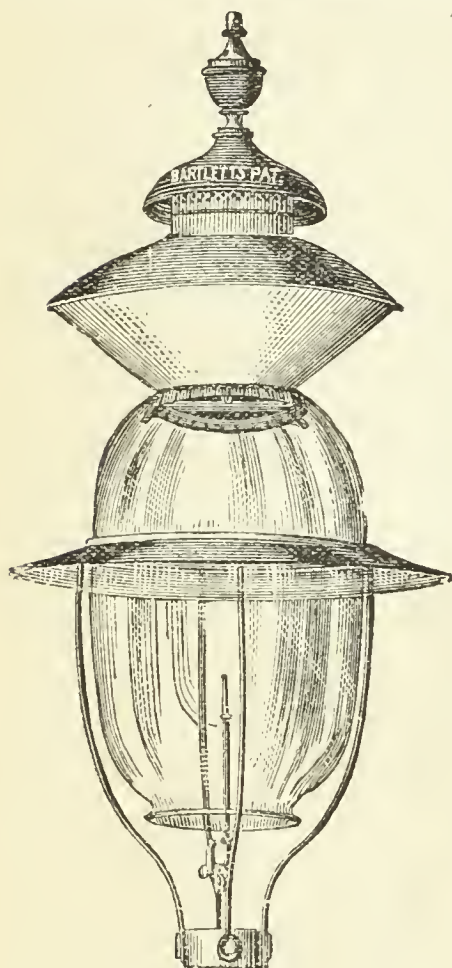

G. S. COOK, Pres. THOS. DAVENPORT (late Davenport Bros.), Sec. & Treas

**BARTLETT
Street Lamp Mfg. Co.**

MANUFACTURERS OF

Bartlett's Patent

GLOBE LAMPS.

FOR

Streets, Parks, Railroad Stations, Public
Buildings, Etc.

LAMP POSTS A SPECIALTY.

Office and Salesroom

No. 35 Howard Street, N. Y. City.

Gas Companies and others intending to erect lamps and posts
will do well to communicate with us.

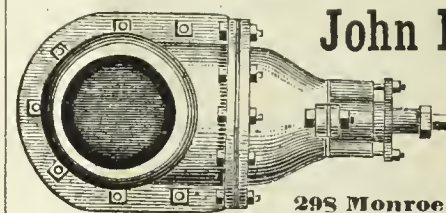

John McLean

Man'facturer of

**GAS
VALVES.**

298 Monroe Street, N. Y.

ENGLISH
"Journal of Gas Lighting."

Issued weekly. New volume commences Jan. 1, 1887. Price, \$7
per annum. Subscriptions taken by

CHARLES NETTLETON, Agent for U. S.,
No. 115 BROADWAY, N. Y. CITY.

GAS

AS A SOURCE OF

LIGHT, HEAT, AND POWER.

By C. J. R. HUMPHREYS.

A Pamphlet of twenty-nine pages, treating of the use of Gas as a
source of Light, Heat, and Power.

DESIGNED FOR DISTRIBUTION BY GAS COMPANIES AMONG THEIR CUSTOMERS AND OTHERS.

Price, 10 cents each, \$5 per 100, \$50 per 1,000.

Gas Companies can have their own imprint placed on cover without extra charge. All orders to be sent to

A. M. CALLENDER & CO.,

No. 42 Pine Street, N. Y. City.

GAS STOVES.

GAS STOVES.

GAS STOVES.

THE AMERICAN METER CO.,

MANUFACTORIES,

508 to 514 West Twenty-second St., N. Y. Arch and Twenty-second St., Phila.

Nos. 244 & 246 North Wells Street, Chicago, Ill.

AGENCIES,

No. 177 Elm Street, Cincinnati, Ohio.

Nos. 122 & 124 Sutter Street, San Francisco Cal.

No. 810 North Second Street, St. Louis, Mo.

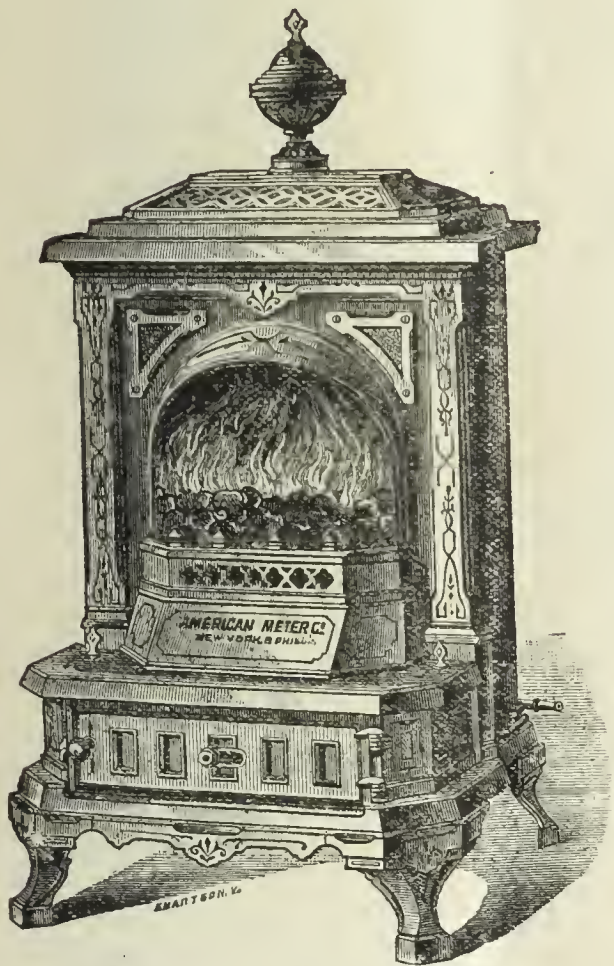

Open Fire Place Heater No. 19.
Fitted with the new Incandescent Gas Fire.

NEW
INCANDESCENT
Gas Fires
AND
OPEN
Fire Place
Heaters.

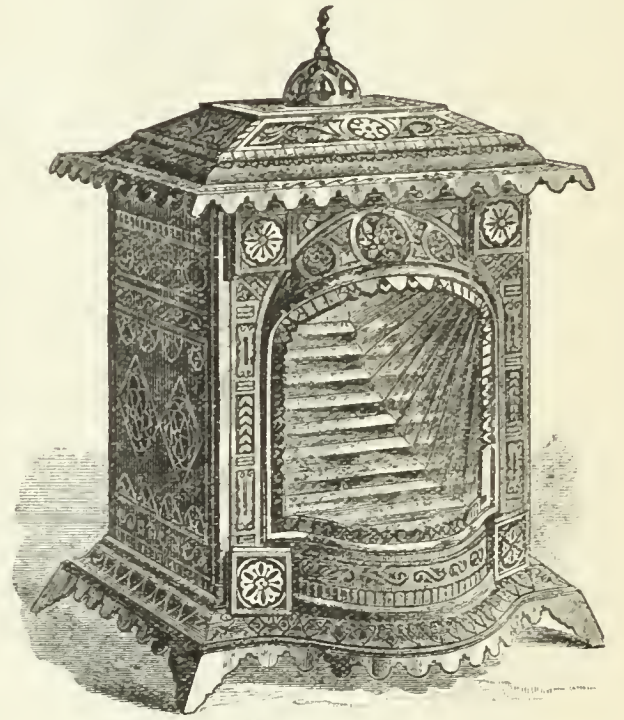

Open Fire Place Heater No. 17C.
Fitted with Illuminating Burners and Copper Reflectors.

We call attention to Special Apparatus Heated by Gas for Manufacturing Purposes.

GAS FURNACES FOR TINMEN'S USE; FURNACES FOR MELTING SOLDER AND TYPE METAL; APPARATUS FOR BENDING CARRIAGE PANELS, NOW IN SUCCESSFUL OPERATION IN CARRIAGE MANUFACTORIES; WATER HEATERS FOR KITCHEN BOILERS, BATHS, ETC., AND FOR ATTACHING TO HEATING COILS AND PIPES FOR CONSERVATORIES.

THE COMPANY MANUFACTURE

GAS STOVES FOR COOKING AND HEATING PURPOSES

In all Sizes, for Domestic, Restaurant, and Hotel Use.

These Stoves may be seen in operation at our Retail Store, No. 223 Sixth Avenue, N. Y. Call and examine.

SEND FOR CATALOGUE OF TWENTY DIFFERENT STYLES OF HEATING STOVES.

RETORTS AND FIRE BRICK.

J. H. CAUTIER & CO.,

CORNER OF

GREENE AND ESSEX STREETS,
JERSEY CITY, N. J.

MANUFACTURERS OF

Clay Gas Retorts,
Gas House Tiles,
Fire Bricks, Etc. Etc.Ground Clay, Fire Brick and
Fire Sand in Barrels,J. H. GAUTIER.
C. E. GREGORY.T. B. GAUTIER.
C. E. GAUTIER.**BROOKLYN**

Clay Retort & Fire Brick Works,

(EDWARD D. WHITE & CO.)

Manufacturers of Clay Retorts, Fire Brick,
Gas House and other Tile.VAN DYKE, ELIZABETH, RICHARDS & PARTITION STS.
Office, 88 Van Dyke St., Brooklyn, N. Y.

RETORTS AND FIRE BRICK.

LACLEDE FIRE BRICK MFG. CO.,

MANUFACTURERS OF

Fire Brick, Gas Retorts,

AND

ST. LOUIS STANDARD SEWER PIPE.

Blast Furnace and Cupola Linings, every description of Fire
Clay Material, Fire Clay Flue Linings, Chimney Tops
Dry Milled and Crude Fire Clays, etc.

OFFICE AND DEPOT

901, 903, and 905 Pine Street,
ST. LOUIS, MO.

ESTABLISHED IN 1845.

B. KREISCHER & SONS,

OFFICE FOOT OF HOUSTON ST., E. R., N. Y.

Gas Retorts,

TILES, FIRE BRICK.

AND EVERYTHING IN THE FIRE CLAY LINE.

RETORTS AND FIRE BRICK.

MANHATTAN

FIRE BRICK & ENAMELLED CLAY

RETORT WORKS.

ADAM WEBER.

CLAY GAS RETORTS

AND RETORT SETTINGS

FIRE BRICKS, TILES, ETC.,

Office and Works, 15th Street and Avenue C., N. Y.



Works,

LOCKPORT STATION, PA.

—ESTABLISHED 1864.—

JAMES GARDNER, JR.,

Successor to WILLIAM GARDNER & SON.

Office, Rooms 19 & 20, Lewis Block,
PITTSBURGH, PA., P. O. Box 373.**Fire Clay Goods for Gas Works.**

CHAS. H. SPRAGUE & SON, No. 70 KILBY STREET, BOSTON, MASS., Agents for the New England States.

OFFICE, 418 to 422 East 23d St., New York.

ESTABLISHED 1856.

WORKS, PERTH AMBOY, NEW JERSEY.

HENRY MAURER & SON,**Excelsior Fire Brick & Clay Retort Works**

CLAY GAS RETORTS, BENCH SETTINGS, FIRE BRICK, TILES, ETC.

CHICAGO

Retort & Fire Brick Works,

OFFICE AND FACTORY,
Clark, Forty-Fifth, and La Salle Streets,
CHICAGO, ILL.

GEORGE C. HICKS, PRES. PAUL P. USTIN, SEC. & TREAS.

STANDARD

Clay Retorts and Settings.

BLOCKS & TILES

Of every Shape and Size to Order.

Standard Fire Bricks.

GEROULD'S IMPROVED RETORT CEMENT.A Cement for patching retorts, putting on mouthpieces, and
making up all hench-work joints. This Cement is mixed ready
use. Economic and thorough in its work. Fully warranted
stick. For recommendations and price list addressC. L. GEROULD,
Manchester, N. H.

Western Agent, H. T. GEROULD, Mendota, Ill.

OAKHILL

GAS RETORT & FIRE BRICK

Works.

Proprietors,

PARKER-RUSSELL MINING & MFG. CO.

City Office, 711 Pine Street,

ST. LOUIS, MO.

Our immense establishment is now employed almost entirely in
the manufacture of**MATERIALS FOR GAS COMPANIES.**We have studied and perfected three important points. Our re-
torts are made to stand changes of temperature, and the strongest
heats of the furnace, and the abrasion of feeding and emptying.
Our customers are in almost every State of the Union, to all of
whom we refer.

THOS. SMITH, Prest. AUGUST LAMBLA, Vice-Prest. & Sup

BALTIMORE

RETORT & FIRE BRICK CO.

MANUFACTORY AT

LOCUST POINT, BALTIMORE, MD.

Connection with the City by Telephone.

Clay Retorts, Blocks & Tiles,

FIRE BRICK, FIRE CLAY,

AND FIRE CEMENT.

Red and Buff Ornamental Tiles and Chim-
ney Tops. Drain and Sewer Pipe (from
2 to 30 inches). Baker Oven Tiles
12x12x2 and 10x10x2.

WALDO BROS., 88 WATER ST., BOSTON, MASS

Sole Agents the New England States

RETORTS AND FIRE BRICK.

REGENERATIVE FURNACES.

EXHAUSTERS.

EVENS & HOWARD,

916 Market St., St. Louis. Mo.

Works, Howard Station, Mo. Pacific R.R.

Fire Brick, Gas Retorts

AND

RETORT SETTINGS.

Sewer Pipe, 3 to 24 in. diameter.

Glass Pot Clay, Ground Fire Clay, in barrels and in bulk. All kinds of Fire Clay Goods.

Cincinnati Gas Retort & Fire Brick Works.

— ESTABLISHED 1872. —

CHAS. TAYLOR,

MANUFACTURER OF

Gas Retorts, Fire Brick, and Tile.

Blast Furnace Linings, Cupola Blocks, Boiler Tiles, Grate Settings, and Stove Linings. Fire Cement, Fire Clay, Fire Sand, and all other Fire Clay Goods.

Branch Works, New Cumberland, W. Va.

GENERAL OFFICE AND WORKS,

Burns St., Cincinnati, Ohio.

Stettiner

Chamotte Fabrik Actien Gesellschaft,

Formerly **DIDIER,**

(Patentees of the Dr. Schilling & Dr. Bunte Regenerative Furnace)

STETTIN, GERMANY.

The attention of all Gas Engineers is called to our Fire-Proof Material, viz.:

CLAY GAS RETORTS

(ENAMELED AND UNENAMELED),

Blocks, Tiles

AND

EXTRA FIRE BRICK,

Pronounced by the highest authorities as superior to and exceeding any other similar manufacture. The component of aluminum contained in our material (up to 45 per cent.) is larger than in any other material heretofore sold in the United States; whilst the uniformity of the goods is assured by the most scrupulous analysis of the clay used.

For any further information and prices please apply to

EMIL LENZ,

2 & 4 Stone St., Room 19, N.Y. City.

PATENTS.

FRANKLIN H. HOUGH,

Solicitor of American & Foreign Patents

925 F. ST., WASHINGTON, D. C.

(NEAR U. S. PATENT OFFICE.)

Personal attention given to the preparation and prosecution of applications for Letters Patent. All business before the U. S. Patent Office attended to for moderate fees. **No Agency in the United States possesses superior facilities for obtaining Patents,** or for ascertaining the patentability of inventions. Copies of patents furnished for 25 cents each. Correspondence solicited.

ADAM WEBER'S
New and Improved Regenerative Furnace.

ESPECIALLY ADAPTED FOR USE IN SMALL GAS WORKS.

A Saving of at Least Forty per Cent. over Old Methods.

Cheapness of construction and absence of elaboration are the chief characteristics of this Furnace. It is also applicable in cases where it is not convenient to excavate deeply below the line of the retort house.

Correspondence respectfully solicited. Descriptive Circulars on application.

Manhattan Fire Brick & Enameled Clay Retort Works.

OFFICE, 633 EAST FIFTEENTH STREET, N. Y. CITY.

MUNICH REGENERATIVE FURNACE

System Drs. Schilling and Bunte.

Greatest Durability! Minimum of Attention!

COMPLETE DISTILLATION IN 3½ HOURS.

Ten to Thirteen Pounds of Coke to Hundredweight of Coal.

NO CLINKER. NO CARBONIC OXIDE IN THE REGENERATIVE FLUES.

Almost Automatic in Action.

The Most Successful Regenerative Furnace in Use.

BARTLETT, HAYWARD & CO.

Agents for the United States.

F. M. ROOTS.

S. C. ROOTS

D. T. ROOTS.

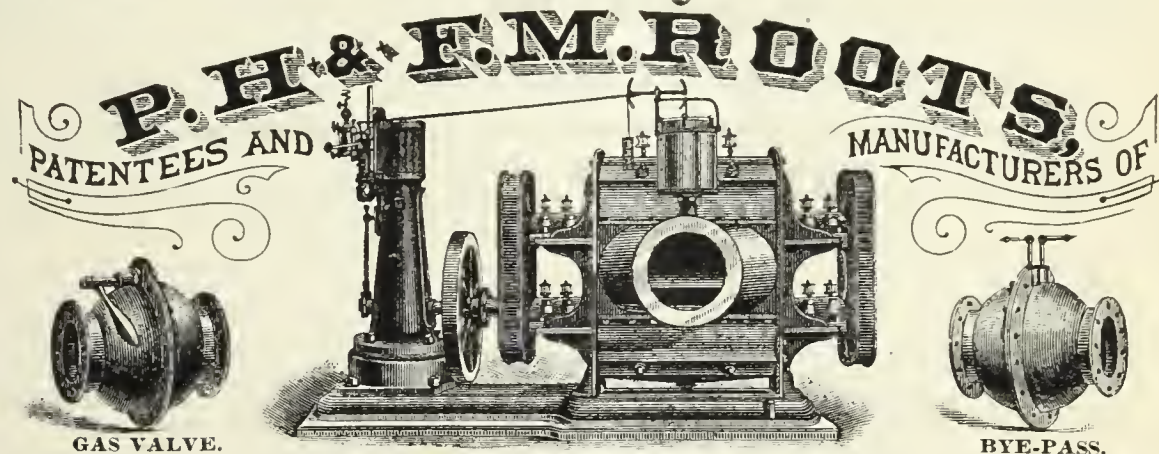

IMPROVED GAS EXHAUSTER,

WITH ENGINE ON SAME BED PLATE, OR WITHOUT.

BYE-PASSES, GAS VALVES, GOVERNORS, ELBOWS, PIPE-FITTINGS, Etc., FURNISHED TO ORDER.

P. H. & F. M. ROOTS, Patentees & Manufacturers, **CONNERSVILLE, IND.**

S. S. TOWNSEND, General Agent, 22 Cortland St.

COOKE & CO., Selling Agents, 22 Cortland St., N. Y.

✚ SEND FOR ILLUSTRATED CATALOGUE AND PRICE LIST. ✚

GAS AND WATER PIPES.

GAS AND WATER PIPES.

ENGINEERS.

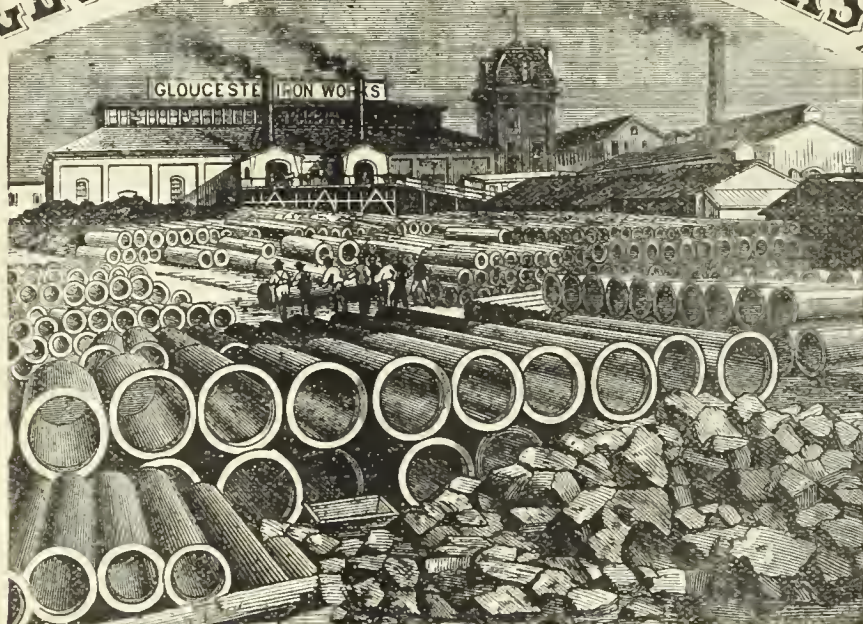
SAM'L R. SHIPLEY, Pres.
HENRY B. CHEW, Treas.JAS. P. MICHELLON, Sec.
WM. SEXTON, Supt.**GLOUCESTER IRON WORKS,**
GLOUCESTER CITY, N. J.

Cast Iron Gas & Water Pipes, Stop Valves, Fire Hydrants, Gasholders, &c.

Office No. 6 North Seventh Street, Philadelphia.

MATTHEW ADDY, President.

W. L. DAVIS, Selling Agent.

GEO. P. WILSHIRE, Sec. & Treas.

Cincinnati and Newport Iron and Pipe Company,

NEWPORT, KY.

Lamp Posts

AND

BENCH CASTINGS

A Specialty.



Large & Heavy Castings for General Work.

Branch

AND

SPECIAL CASTINGS

FOR GAS & WATER CO'S.

Manufacture Pipe from 2 to 48 inches. All work guaranteed first quality.

Pancoast & Rogers.**WROUGHT IRON PIPE,**

VALVES AND GATES,

Cast Iron Gas & Water Pipe.

28 Platt and 15 Gold St., New York.

GEO. SHEPARD PAGE,

No. 69 Wall Street, N. Y. City.

REPRESENTING

THE BOWER GAS LAMP.

C. & W. Walker's Carbonic Acid & Tar Extracting Washer

B. DONKIN & CO.'S PAT. IMP. GAS VALVE.

Young & Beilby's Patents. Henry Aitkin's Patents.

R. P. SPICE, London, Eng. HENRY SIMON, Manchester, Eng.

The Management of Small Gas Works.

By C. J. R. HUMPHREYS. Price, \$1.

A. M. CALLENDER & CO., 42 Pine St., N. Y.

P. D. WANNER, Chairman. A. H. MELLERT, Sec. & Treas.

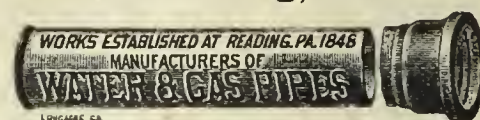
MELLERT FOUNDRY & MACHINE CO., Ltd.
Reading, Pa.Specials—Flange Pipe, Valves and Hydrants,
Lamp Posts, Retorts, etc.

General Foundry and Machine Work.

JOHN FOX, Selling Agent. 160 Broadway, N. Y.

THE OHIO PIPE COMPANY,

MANUFACTURERS OF

Cast Iron Gas & Water Pipe,

BRANCH AND SPECIAL CASTINGS.

Gas-House Bench Castings, Hydraulics, Lamp Posts, Flange Pipe
and Specials, Architectural Castings, Building Columns,
Joists, Cellar Grates, Sash Weights, etc.

GENERAL FOUNDERS AND MACHINISTS.

Columbus, Ohio.

M. J. DRUMMOND,

SPECIAL CASTINGS AND LAMP POSTS.

95 Liberty St., - New York.

JOS. R. THOMAS, C.E.,May be Consulted on all Mat-
ters Relating to Gas Works
and Gas Manufacture.

ADDRESS THIS OFFICE.

WM. FARMER, ENGINEER,

32 Park Place, Room 36, New York.

THE CHEMIST'S ASSISTANT; OR, KINDERGARTEN SYSTEM OF CHEMISTRY.A system by which the elements and their valences are repre-
sented by illustrations and solid bodies.

BOX AND PAMPHLET COMPLETE, \$2.50.

WM. HENRY WHITE,

CONSULTING AND CONSTRUCTING

Gas Engineer & ContractorEstimates, Plans, and Specifications furnished for new works or
extensions of existing works.

No. 32 Pine Street, New York City.

Correspondence solicited.

WM. GARDNER,
Gas Engineer,

Lewis Block, Room 20, Pittsburgh, Pa.

Those who intend to make alterations in existing gas plants, or
who contemplate the erection of new works, will find it to their
interest to open correspondence with the above. Plans made
and estimates furnished.

GAS LAMPS.

SCRUBBERS AND CONDENSERS.

The Siemens and Lungren REGENERATIVE GAS LAMPS.

A System of Burning Gas whereby its Illuminating Power is Increased from 300 to 400 per ct. without the Expense, Trouble and Annoyance resulting from the use of Hydrocarbon Enriching Material.

The Siemens-Lungren Company received the only Silver Medal or Highest Award for Gas Burners at the "Novelties" Exhibition of the Franklin Institute, held at Phila., Oct., '85.

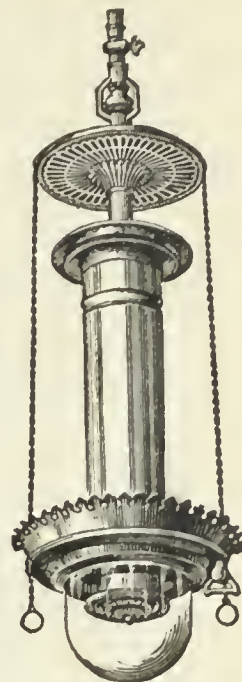

LUNGREN LAMP

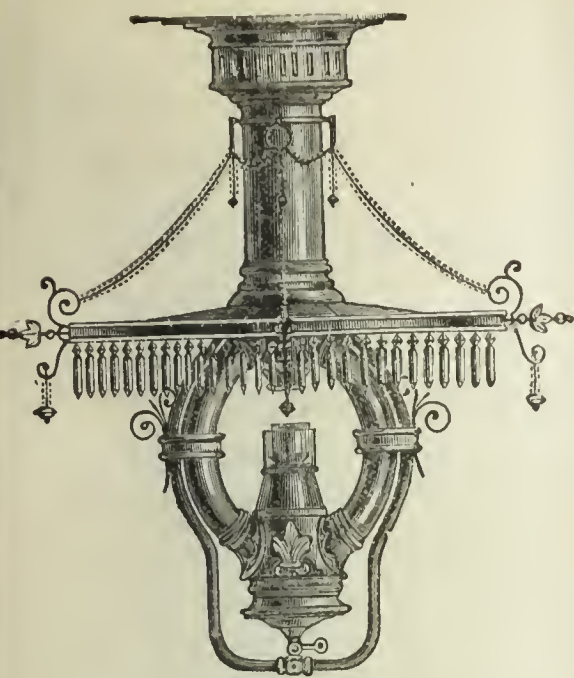

SIEMENS LAMP.

THIRTEEN CANDLE POWER PER CUBIC FOOT OF GAS!

This result is obtained

SIMPLY BY THE SCIENTIFIC APPLICATION OF THE REGENERATIVE PRINCIPLE.

Consequently this largely increased illumination is always maintained without further cost and frequent attention.

THE SIEMENS-LUNCREN COMPANY,

N. E. Cor. 21st. St. and Washington Av., Phila., Pa.

THE PATENT "STANDARD" WASHER-SCRUBBER

Has been adopted by gas companies in all parts of the world. Between 300 and 400 companies, with the enormous daily output of over 300,000,000 cubic feet, are now using it. "Standard" Washer-Scrubbers have been erected for the following gas light companies since Jan. 1, 1886:

WALLASEY, ENGLAND.....	750,000 cubic feet.
NEWARK, ENGLAND.....	350,000 "
BUFFALO, U. S. (MUTUAL).....	500,000 "
BERLIN, GERMANY.....	1,250,000 "
SO. BRISBANE, AUSTRALIA.....	300,000 "
LEEDS, ENGLAND.....	2,600,000 "
FURTH, GERMANY.....	400,000 "
FREIBURG, GERMANY.....	200,000 "
NINE ELMS, LONDON.....	3,000,000 "
MELBOURNE, AUSTRALIA (2).....	3,000,000 "
GLUCKAUF COKE WORKS, GERMANY.	200,000 "
BOURNEMOUTH, ENGLAND.....	1,000,000 "

RICHMOND, SURREY, ENGLAND.....	1,500,000 cubic feet.
BRIDGEPORT, U. S.....	500,000 "
TORONTO, CANADA.....	1,000,000 "
HARTFORD, U. S.....	1,000,000 "
DETROIT, U. S.....	750,000 "
SINGAPORE, CEYLON.....	300,000 "
BRUNSWICK, GERMANY.....	300,000 "
LILLE, FRANCE.....	750,000 "
CADIZ, SPAIN.....	300,000 "
READING, ENGLAND.....	2,000,000 "
LINCOLN, U. S.....	250,000 "
ST. LOUIS, U. S. (LACLEDE).....	1,000,000 "
BROOKLYN, U. S.....	2,000,000 "

That this apparatus is really the *standard* is indicated by the following names of important houses who represent this invention in the different countries of the world:

FRANCE & BELGIUM, Mons. J. A. Berly, 31 Rue Boindod, Paris. HOLLAND & DUTCH COLONIES, Mess. W. Hoven & Zoon, Rotterdam.
 GERMANY and AUSTRO-HUNGARY, Berlin-Anhaltische-Actiengesellschaft, Berlin, Moabit, and Dessau.
 RUSSIA, Mr. F. Bley, Galernaya, 44, St. Petersburg. SPAIN, Mess. Nicolas, Chamon, Foiret & Cie., 29 Rue Claude-Vellefaux, Paris.
 ITALY & MALTA, Sig. E. Canziani, 26 & 28 Portici, Vittorio Emmanuele, Genoa. Sig. Fratelli Scheuer, Via Chiaja, 124, Naples
 NEW SOUTH WALES, Messrs. W. Coward & Sons, 143 Queen Victoria St., London.
 NEW ZEALAND and VICTORIA, Messrs. G. D. Jennings & Co., 28 Gracechurch St., London.

Companies in the U. S. adopting this apparatus can now be assured of a market for the Ammoniacal Liquor at a remunerative price. Correspondence for purchase of "Standards" and Ammoniacal Liquor is solicited by the

SOLE AGENT AND MANUFACTURER FOR THE WESTERN HEMISPHERE,
GEO. SHEPARD PAGE, 69 WALL STREET, NEW YORK.

GAS WORKS APPARATUS AND CONSTRUCTION.

GAS WORKS APPARATUS AND CONSTRUCTION.

WORKS: { MILLVILLE, N. J.
FLORENCE, "
CAMDEN, "

R. D. WOOD & CO.,

OFFICES: { 400 CHESTNUT ST.,
PHILADELPHIA.

GAST-IRON PIPE 1½ to 72 Inches in Diameter.

Water Machinery and Gas Apparatus.

HEAVY CASTINGS.

HOLDERS,

LAMP POSTS,

VALVES,

PURIFIERS,

CONDENSERS,

BENCH WORK,

METER CASES.

FLOORS AND ROOFS,

FLANGED PIPE,

FIRE HYDRANTS,

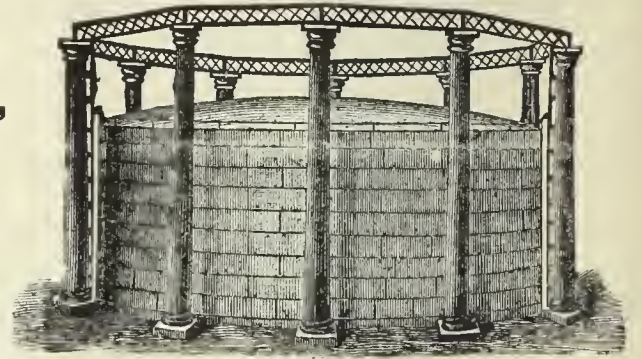
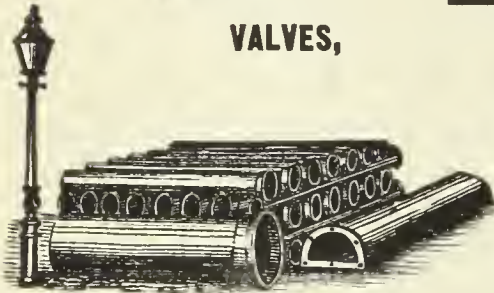

Estimates and Specifications for
NEW WORKS or **EXTENSIONS**
or **ALTERATIONS** of **OLD ONES.**

SMITH & SAYRE MFG. COMPANY,

G. G. PORTER, Prest.

245 Broadway, N. Y.

CHAS. W. ISBELL, Sec'y.

Machinery & Apparatus for Gas Works

Drawings, Plans, and Estimates Furnished for the Improvement, Extension, or Alteration of Gas Works, or for the Construction of New Works.

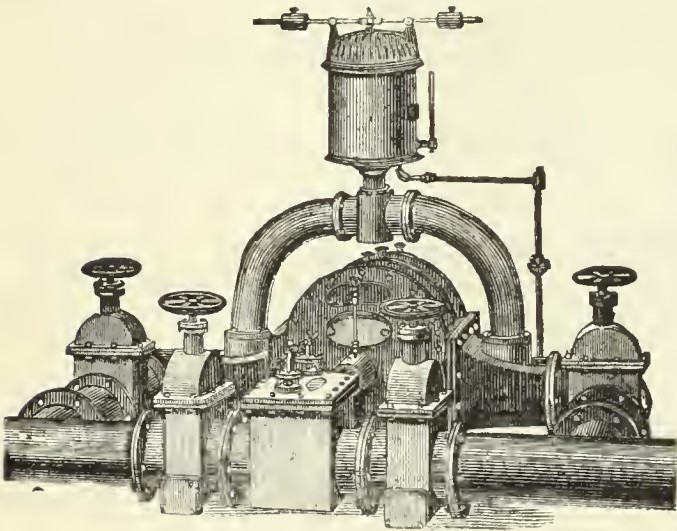

Mackenzie's Patent Rotary and Steam Jet Gas Exhausters, Governors, Compensators, Condensers, Washers, Scrubbers. Isbell's Patent Automatic Street Pressure Governor, Gas and Water Valves, Hydraulic Main Dip Regulator, Bench Castings, etc. Purifying Boxes and "Standard" Scrubbers. Isbell's Patent Self-Sealing Retort Doors.

SOUTHWARK FOUNDRY AND MACHINE COMPANY,

Successors to MERRICK & SONS,

GAS APPARATUS,

Holder, Purifiers, Washers, Etc., Etc. Boiler and Tank Work. Steam Engines. Hydraulic Machinery. Bessemer Plants, Etc.

Washington Ave. and Fifth Street, Philadelphia, Pa.

MORRIS, TASKER & CO.,

Limited,

Builders of Gas Works,

PHILADELPHIA PA.

GOODWIN'S DIRECTORY

OF THE

GAS LIGHT COMPANIES OF THE UNITED STATES & CANADA

Price, \$10.00.

Orders may be sent to

A. M. CALLENDER & CO., No. 42 Pine Street, N. Y. City.

GAS WORKS APPARATUS AND CONSTRUCTION.

GAS WORKS APPARATUS AND CONSTRUCTION.

JAMES R. FLOYD,

(SUCCESSOR TO HERRING & FLOYD)

Oregon Iron Works,

531 to 543 West 20th St., N. Y.

Practical Builders of Gas Works,

MANUFACTURERS OF

ALL KINDS OF CASTINGS

AND

APPARATUS FOR GAS-WORKS.

BENCH CASTINGS

from benches of one to six Retorts each.

WASHERS: MULTITUBULAR AND AIR CONDENSERS; CONDENSERS; SCRUBBERS

wet and dry), and

EXHAUSTERS

for relieving Retorts from pressure.

BENDS and BRANCHES all sizes and description.

FLOYD'S PATENT MALLEABLE RETORT LID.

PATENT

SELF-SEALING RETORT LIDS.

FARMER'S

PATENT BYE-PASS DIP-PIPE.

SABBATON'S PATENT

FURNACE DOOR AND FRAME.

BUTLER'S

COKE SCREENING SHOVELS.

GAS GOVERNORS,

and everything connected with well regulated Gas Works at low price, and in complete order.

SELLER'S CEMENT

for stopping leaks in Retorts.

N. B.—STOP VALVES from three to thirty inches—at very low prices.

Plans, Specifications, and Estimates furnished.

Bouton Foundry Co.,

FOUNDERS AND MACHINISTS,

CHICAGO, ILL.

Gas Works Apparatus,

PURIFIERS, CONDENSERS,

Bench Work,

SPECIALS, LAMP POSTS,

SCRUBBERS,

Iron Roofs and Floors.

Plans and Estimates furnished for new works or extensions of old works.

BOOKS.

DISTILLATION OF COAL TAR AND AMMONIACAL LIQUOR.

By **GEORGE LUNGE.** Price \$8.50.

A TREATISE ON THE COMPARATIVE COMMERCIAL VALUES OF GAS COALS AND CANNELS.

By **DAVID A. GRAHAM.** 8vo., Cloth. Price \$3.

Orders for these books may be sent to this office.

A. M. CALLENDER & CO.,

46 Pine St., N. Y. City.

CONTINENTAL WORKS.



GASHOLDERS OF ANY MAGNITUDE.

T. F. ROWLAND, Proprietor,

GREENPOINT, BROOKLYN, N. Y.

ENGINEER AND MANUFACTURER OF

GAS-HOLDERS.

CONDENSERS, SCRUBBERS, VALVES,

PURIFIERS, RETORTS, and HY-

DR АуLIC MAINS,

and all other articles connected with the Manufacture and Distribution of Gas. Plans and Specifications prepared and Proposals given for the necessary Plant for Lighting Cities, Towns, Mansions, and Manufactories.

H. RANSHAW, Pres. & Mangr

WM. STACEY, Vice-Prest.

T. H. BIRCH, Asst. Mangr.

R. J. TARVIN, Sec. & Treas.

STACEY MFG. CO.,

MANUFACTURERS OF

Single and Telescopic Gasholders,

IRON ROOFS, BRIDGES, LAMP POSTS.

Water and Oil Tanks, Coal Elevator Cars,

COKE CRUSHERS, BENCH CASTINGS,

And all kinds of Wrought and Cast Iron Work used in the erection of Coal and Oil Gas Works, Rolling Mill Machinery and Heavy Castings a Specialty.

Foundry:

33, 35, 37 & 39 Mill Street.

Wrought Iron Works:

16, 18, 20, 22, 24 & 26 Ramsey Street:

Cincinnati, Ohio.

BARTLETT, HAYWARD & CO.,

Office, German & Calvert.

BALTIMORE, MD.

Works, Pratt & Scott.

PURIFIERS.

Roofs.
Bench Castings.

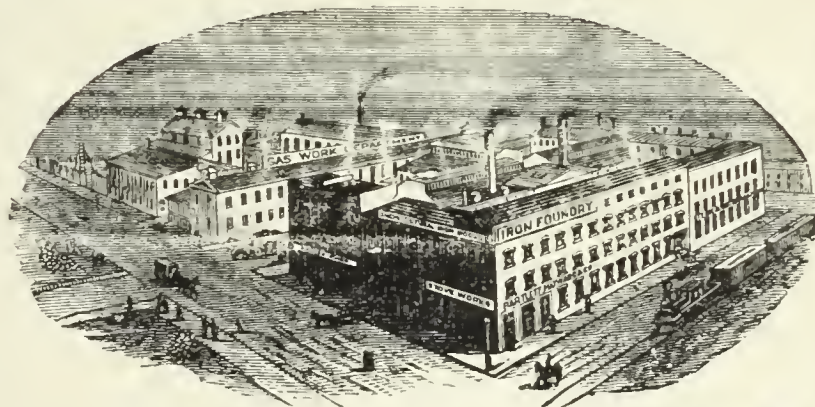

SCRUBBERS.

CONDENSERS
BOILERS.

GASHOLDERS.

CONSTRUCTING ENGINEERS AND BUILDERS OF GAS WORKS.

1842. **DEILY & FOWLER, 1887.**

Laurel Iron Works.

Address, No. 39 Laurel Street, Philadelphia, Pa.

MANUFACTURERS OF

GASHOLDERS,

Single or Telescopic, with Cast or Wrought Iron Guide Frames.

Holder Built Since 1881:

Scranton, Pa. (2d)
West Point, N. Y.
Fitchburgh, Mass.
New London, Conn.
Derby, Conn.
Bridgeport, Conn.
Allegheny, Pa. (1st.)
St. Hyacinth, Can.
Norwalk, O.
Brattleboro, V.
Waltham, Mass. (2d.)
West Chester, Pa.
Baltimore, Md.

Hollidaysburg, Pa.
Galveston, Texas (2d.)
Marlboro, Mass.
Denver, Col.
Chicago, Ill. (West Side).
Pittsburgh, Pa. (S. Side).
Pawtucket, R. I.
Brookline, Mass.
Sherbrooke, Can.
Burlington, N. J. (2d.)
Bridgeton, N. J.
Bay City, Mich.
Erie, Pa.

Jackson, Mich.
Kalamazoo, Mich. (3d.)
Glen Island, N. Y.
Warren, Ohio.
Bath, N. Y.
Lynn, Mass.
New Bedford, Mass.
Waterbury, Conn.
Deseronto, Can.
Hoodie Falls, N. Y. (2d.)
Bethlanem, Pa.
Atlanta, Ga. (1st.)
Savannah, Ga.

Montgomery, Ala.
Newport, R. I.
Portland, Oregon.
Allegheny, Pa. (2d.)
Atlanta, Ga. (2d.)
N.Y. City (Central Gas Co)
Lynchburg, Va. (2d.)
Saylesville, R. I.
Rondout, N. Y.
Atlantic City, N. J.
Augusta, Ga.
Waltham, Mass. (2d.)
Mahanoy City, Pa.

New Castle, Pa.
Long Island City, N. Y.
Macon, Ga.
York, Pa.
Chester, Pa.
Hazleton, Pa. (2d.)
Novelties Exhib., Phila
State Island, N. Y.
Saugerties, N. Y.
Clinton, Mass. (Lan. M)
Chattanooga, Tenn.
Galveston, Texas. (3d.)
Omaha, Neb.

GAS COALS.

GAS ENRICHERS.

EXHAUSTERS.

JAMES D. PERKINS.

PERKINS & CO.,

F. SEAVERNS.

General Sales Agents for

The Youghioghenny River Coal Company's**OCEAN MINE YOUGHIOGHENY GAS COAL.**

The Coal from the Ocean Mine (recently operated by *Messrs. W. L. Scott & Co.*, of Erie, Pa.,) is now used by all the leading Gas Companies in the United States from Maine to Texas, and is recognized as *the only reliable Youghioghenny Gas Coal.* (See Map on p. 87 of this Journal, Feb. 16, 1885.)

P. O. Box 3695,
New York.**PERKINS & CO., 228 and 229 N. Y. Produce Exchange.**BEAVER STREET
ENTRANCE.**BRECKENRIDGE CANNEL,
OF KENTUCKY.**

This colliery was re-opened in June of the present year, and the Cannel is now being delivered to thirty of the leading Gas Companies in this country. As an enricher ONE TON of this Cannel will do the work of TWO TONS of any other available Cannel. It can be delivered in parcels of one car load or more to any point in the United States or Canada. (See AMERICAN GAS LIGHT JOURNAL, June 16, '86, pp. 346-7.)

P. O. Box 3695,
New York.**PERKINS & CO., 228 and 229 N. Y. Produce Exchange**BEAVER STREET
ENTRANCE.**JAMES & WILLIAM WOOD,****Gas and Cannel Coal Contractors,**

No. 40 St. Enoch Sq., Glasgow. No. 2 Talbot Court, London.

Proprietors of the **BATHVILLE COLLIERIES** (which produce the celebrated **BOGHEAD CANNEL**), Shields, Shieldmuir, Drumpeller, and other Collieries. This Firm offer

STANDARD CANNELS,**Unequaled as Gas Enrichers.**

Analyses, prices, and all further information furnished on application to

Agency for U. S., Room 93, Nos. 2 & 4 Stone St., N.Y. City.O. J. BENHAM,
President.C. M. HIGGINS,
Secretary.L. H. SEVERANCE,
Treasurer.**The Forest City Naptha Co.,**

REFINERS OF

Red Crown Brand**NAPTHA AND GASOLINES.**

ALSO MANUFACTURERS OF

**A Special Grade of Naptha for
Gas Companies****FOR ENRICHING COAL GAS.**

Correspondence solicited.

No. 43 Euclid Avenue, Cleveland, Ohio.

To Gas Companies.We make to order **CAP BURNERS** to burn any amount under a stated pressure. Send for samples.Also, **SERVICE CLEANERS, DRIP PUMPS, and STREET MAIN PROVING APPARATUS.****C. A. GEFROER,**

248 N. 8th Street, Phila., Pa.

The Wilbraham Gas Exhauster,**"BAKER SYSTEM,"**

WITH ENGINE ATTACHED, ON SAME BED PLATE OR WITHOUT.

Best, Cheapest and Most Durable Exhauster known.**WILBRAHAM BROS.,**

No. 2320 Frankford Avenue, Philadelphia, Pa.

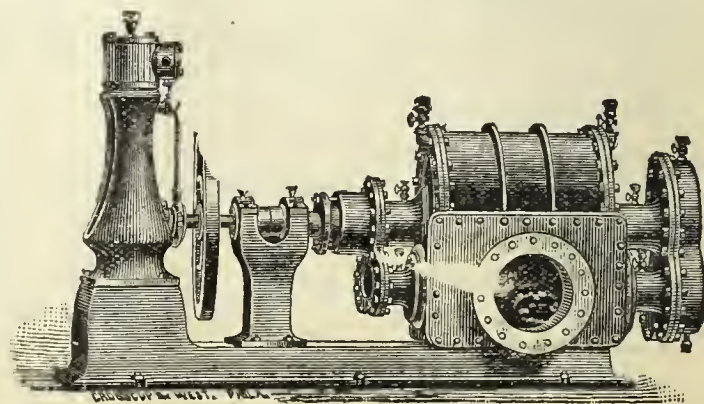

COKE CRUSHERS.

GAS COALS.

GAS COALS.

Newburgh Orrel Coal Co.,

MINERS AND SHIPPERS OF

Mountain Brook Steam and Smithing Coals,

AURORA, TYRCONNELL & PALATINE GAS COALS.

Foundry & Crushed Coke Shipped Direct from Ovens

Mines Situated at

Newburgh, Flemington & Fairmont, W.Va.

HOME OFFICE,

33 S. Gay St., Baltimore.

CHAS. MACKALL, Gen. Mangr.

CHAS. W. HAYS, Agent in New York,

Room 147, WASHINGTON BUILDING, No. 1 Broadway.

Shipping wharves at Locust Point, Baltimore.

THE DESPARD COAL COMPANY

OFFER THEIR SUPERIOR

DESPARD COAL

To Gas Light Companies and Manufacturers of Fire Clay Throughout the Country.

ROUSEL & HICKS, } AGENTS. { BANGS & HORTON }
71 Broadway, N. Y. } { 16 Kilby St., Boston }

Mines in Harrison Co., West Va. Wharves, Locust Point,

Company's Office, 15 German St., Baltimore, Md.

Among the consumers of Despard Coal we name: Manhattan Gas Light Co., N. Y.; Metropolitan Gas Light Co., N. Y.; Jersey City, (N. J.) Gas Light Co.; Washington (D. C.) Gas Light Co.; Portland (Maine) Gas Light Co. Reference to them is requested.

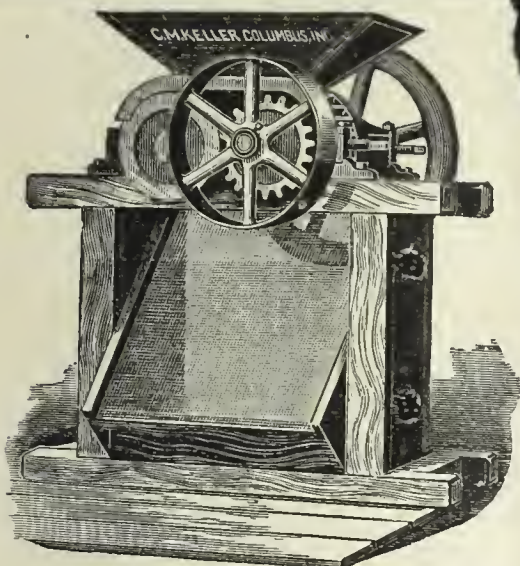

Keller's Adjustable Coke Crusher.

SIMPLE, STRONG, AND DURABLE.

C. M. Keller, Sec. & Supt. Gas Lt. & Coke Co. Columbus, Ind.

Correspondence Solicited.

GAS COMPANIES, ATTENTION!

Increase the demand for Coke by using the

Star Coke Breaker.

SIMPLE, CHEAP, DURABLE. EASILY SHARPENED BY ANY BLACKSMITH.

B. J. ALLEN, Newark Gas Co., Newark, N. J.

King's Treatise on Coal Gas.

The most complete work on Coal Gas ever published

Three Vols. Bound, \$30.

A. M. CALLENDER & CO., 42 Pine St., N. Y.

THE PENN GAS COAL CO.

OFFER THEIR

Coal, Carefully Screened & Prepared for Gas Purposes.

Their Property is located in the Youghiogheny Coal Basin, near Irwin and Penn Stations on the Pennsylvania Railroad, and on the Youghiogheny River.

Principal Office:

209 SOUTH THIRD STREET, PHILA., PA.

Points of Shipment:

Pennsylvania Railroad Piers; Greenwich Wharves, Delaware River; Pier No. 1 (Lower Side), South Amboy, N. J.

Chesapeake & Ohio Railway Coal Agency,

FOR THE SALE OF THE

Superior Kanawha Gas Coals, Cannelton Cannel,

Also, SPLINT AND STEAM COALS.

From the Kanawha and New River Regions, on the line of the Chesapeake & Ohio R'way.

B. ORCUTT, Sales Agent. | OFFICE, 150 BROADWAY, N. Y.

FRANCIS H. JACKSON, Prest. EDMUND H. MCCULLOUGH, V.-Prest. CHAS. F. GODSHALL, Treas. H. C. ADAMS, Sec.

THE WESTMORELAND COAL CO.

Chartered 1854.

Mines situated on the Pennsylvania and the Baltimore and Ohio Railroads, in Westmoreland County, Penn.

POINTS OF SHIPMENT:

PHILADELPHIA, BALTIMORE, SOUTH AMBOY, N. J., WATKINS (SENECA LAKE), N. Y.

Since the commencement of operations by this Company its well-known Coal has been largely used by the Gas Companies of New England and the Middle States, and its character is established as having no superior in gas giving qualities, and in freedom from sulphur and other impurities.

Principal Office, 224 South 3d St., Phila., Pa.

A. M. SCOTT, PRESIDENT. A. DEMPSTER, C.E., SECRETARY. W. K. GILLESPIE, TREASURER.

MONONGAHELA AND PETERS CREEK GAS COAL CO.,

PRODUCERS OF

Coal Bluff Gas Coal.

MINES LOCATED ON THE MONONGAHELA DIVISION OF THE PENNSYLVANIA RR. IN THE CENTRAL PORTION OF THE PITTSBURGH COAL FIELD.

Points of Shipment—Buffalo, Cleveland, Erie, Chicago, New Orleans.

Since the introduction of Coal Bluff Gas Coal it has taken rank among the few first-class Gas Coals, and acknowledges no superior in gas-giving qualities, ease of working, quality of coke, and freedom from impurities

General Eastern Agents, ANDREW LANGDON & CO., Buffalo, N. Y.

General Western Agents, ANDREW LANGDON & CO., Chicago, Ill.

Milwaukee Agents, F. R. BUELL & CO., - - - Milwaukee, Wis.

General Office, 43 Sixth Ave., Pittsburgh, Pa.

GAS METERS.

GAS METERS.

GAS METERS.



INTERNATIONAL--1876--EXHIBITION.

The U. S. Centennial Commission

HAVE DECREED AN AWARD TO

HARRIS, GRIFFIN & CO.,

Twelfth and Brown Streets, Philadelphia, Pa. No. 49 Dey Street, N. Y. City, and No. 75 North Clinton Street, Chicago, Ill.

FOR THE FOLLOWING REASONS :

The Exhibit consists of a Series of METERS from the Largest Size Station Meters for the use of the MANUFACTURE OF GAS, to those for the use of the ORDINARY CONSUMER. The Instruments are WELL MADE, RELIABLE as to INDICATION, and embody a number of sundry improvements which, with the general character of the Exhibit, entitle the whole to commendation.

Attest—J. L. CAMPBELL,
Secretary, pro-tem.

Signed—A. T. GOSHORN,
Director General

J. B. HAWLEY,
President

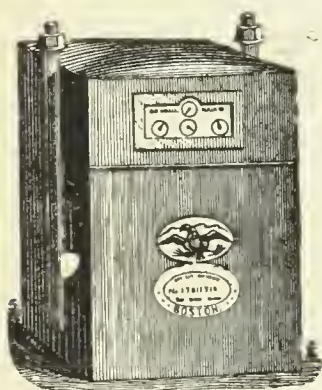

Dry Gas Meter.

With 39 years' experience and the best facilities for manufacturing, is enabled to furnish reliable work and answer orders promptly.

NATHANIEL TUFTS,

No. 153 Franklin Street, Boston, Mass.,

MANUFACTURER OF

DRY GAS METERS.

Station Meters of all Capacity.

Test and Experimental Meters, Pressure Registers, Pressure Gauges, Pressure and Vacuum Gauges.

METER PROVERS, PHOTOMETERS, STREET LANTERNS, ETC., ETC.

Patent Cluster Lanterns for Street Illumination.

SCIENTIFIC BOOKS.

We are prepared to furnish to Gas Managers, and others interested in the topics treated of, the following books, at prices named :

KING'S TREATISE ON THE MANUFACTURE OF COAL GAS. Three vols.; \$10 per vol.	PRACTICAL TREATISE ON HEAT, by THOMAS BOX. Second edition. \$5.	THE GAS MANAGER IN THE LABORATORY, by a Practical Student. 8vo., Cloth. \$1.50.
GAS MANUFACTURE, by WILLIAM RICHARDS. 4to., with numerous Engravings and Plates, in Cloth binding. \$12.	GAS WORKS—THEIR ARRANGEMENT, CONSTRUCTION, PLANT, AND MACHINERY. \$8.	THE DOMESTIC USES OF COAL GAS, AS APPLIED TO LIGHTING, by W. SUGG. \$1.40.
THE GAS ANALYST'S MANUAL, by F. W. HARTLEY. \$2.50.	COAL; ITS HISTORY AND USE, by PROF. THORPE. \$3.50.	DISTILLATION OF COAL TAR AND AMMONIACAL LIQUOR by GEO. LUNGE. \$8.50.
TECHNICAL GAS ANALYSIS. \$2.80.	THE GAS WORKS OF LONDON, by COLBURN. 60 cents.	A TREATISE ON THE COMPARATIVE COMMERCIAL VALUES OF GAS COALS AND CANNELS, by D. A. GRAHAM 8vo., Cloth. \$3.
GAS MANAGER'S HANDBOOK, by THOS. NEWBIGGING. \$4.80.	THE GAS FITTER'S GUIDE, Showing the Principles and Practice of Lighting with Coal Gas, by JOHN ELDREDGE. 40 cents.	GAS AS A SOURCE OF LIGHT, HEAT, AND POWER, by C. J. R. HUMPHREYS. 10 cents.
GAS CONSUMER'S GUIDE. \$1.	GAS WORKS, AND MANUFACTURING COAL GAS, HUGHES. \$2.20.	GAS COMPANIES DIRECTORY. \$10.
A GUIDE TO GAS LIGHTING. 40 cents.	THE MANAGEMENT OF SMALL GAS WORKS, by C. J. R. HUMPHREYS. \$1.	GAS VERSUS ELECTRIC LIGHT. 50 cents.
GAS MEASUREMENT AND GAS METER TESTING, by F. W. HARTLEY. \$1.60	MANUAL FOR GAS ENGINEERING STUDENTS, by D. LEE, 40 cents.	PURIFICATION OF COAL GAS, by R. P. SPICE. 8vo. \$3.
GAS CONSUMER'S HANDBOOK, by WILLIAM RICHARDS, C.E.; 18mo., Sewed. 20 cents.	HOW TO MANAGE GAS, by F. WILKINS. Paper. 20 cents.	
A PRACTICAL TREATISE ON GAS AND VENTILATION with Special Relation to Illuminating, Heating, and Cooking by Gas, by E. E. PERKINS. \$1.25.		

The above will be forwarded by express, upon receipt of price. We take especial pains in securing and forwarding any other Works that may be desired, upon receipt of order. All remittances should be made by check, draft, or post office money order.

A. M. CALLENDER & CO., No. 42 Pine Street, New York.

KING'S TREATISE ON COAL GAS.

The most complete work on Coal Gas ever published. Three vols., bound \$30

A. M. CALLENDER & CO., No. 42 Pine Street, New York.

GAS METERS.

GAS METERS.

GAS METERS.

T. C. HOPPER, Pres. G. J. McGOURKEY, Vice-Pres. (New York). WM. N. MILSTED, Gen. Supt. & Treas. (New York). WM. H. DOWN Sec.

AMERICAN METER COMPANY,

WET AND DRY GAS METERS.

PRESSURE REGISTERS.

METER PROVERS.

STATION METERS.

PRESSURE & VACUUM REGISTERS.

PORTABLE TEST METERS.

EXHAUSTER GOVERNORS.

PRESSURE & VACUUM GAUGES.

EXPERIMENTAL METERS.

DRY CENTRE VALVES.

ORESSON GAS REGULATORS.

AMMONIA TEST METERS.

GOVERNORS FOR GAS WORKS.

MARSLAND WATER METERS.

BAR AND JET PHOTOMETERS.

Manufactories:

GAS STOVES,

Agencies:

112 W. 22d St., N. Y.
Arch & 22d Sts., Phila.

SUGG'S "STANDARD" ARGAND BURNERS,
SUGG'S ILLUMINATING POWER METER,
Wet Meters, with Lizar's "Invariable Measuring" Drum.

177 Elm Street, Cincinnati.
244 & 246 N. Wells Street, Chicago.
810 North Second Street, St. Louis.
122 & 124 Sutter St., San Francisco.

HELME & McILHENNY,

(Successors to Harris & Brother. Established 1848.)

GAS METER MANUFACTURERS,

CONTINUE AS HERETOFORE AT THE OLD ESTABLISHMENT.

Nos. 1339 to 1349 Cherry Street, Philadelphia, Pa.,

To Manufacture Wet and Dry Gas Meters, Station Meters, Experimental Meters, Meter Provers, Center Seals, Pressure Registers

GOVERNORS, INDICATORS, PHOTO METERS, & ALL OTHER KINDS OF APPARATUS FOR USE IN GAS WORKS.

From our long practical experience of the business, and under our personal supervision of all work, we can guarantee all orders to be executed promptly in every respect satisfactorily.

WM. WALLACE GOODWIN, Pres. and Treas.

WM. H. MERRICK, V.-Pres.

S. L. JONES, Sec.

S. V. MERRICK, Supt.

THE GOODWIN GAS STOVE AND METER COMPANY,

Successors to W. W. GOODWIN & CO.

1012, 1014 and 1016 Filbert St., Phila., Pa. 142 Chambers St., New York.
76 Dearborn St., Chicago, Ill.

WALDO BROS., Agents, 88 Water St., Boston.

MANUFACTURERS OF THE "SUN DIAL" GAS STOVES, FOR COOKING AND HEATING PURPOSES.

Dry and Wet GAS METERS, Station Meters (Square, Cylindrical or in Staves) Glazed Meters, King's and Sugg's Experimental Meters, Lamp Post Meters, Etc., Etc., Meter Provers (sizes 2, 5 and 10 feet), Pressure Guages of all kinds, Pressure Registers, Pressure and Vacuum Registers, Pressure Indicators (sizes 4 inch, 6 inch and 9 inch), King's Pressure and Vacuum Gauges, Dry and Wet Centre Seals, Dry and Wet Governors, Exhauster Governors, Photometers of all descriptions. Letheby's Sulphur and Ammonia Test Apparatus complete—also Testing and Chemical Apparatus of all kinds, and of the most perfect description, for all purposes relating to Gas.

GOODWIN'S IMPROVED LOWE'S JET PHOTOMETER.

Agents for Bray's Patent Gas Burners and Lanterns.

Special attention to repairs of Meters, and all apparatus connected with the business.
All work guaranteed first class in every particular, and orders filled promptly.

G. B. EDWARDS, Mang'r, New York.
E. H. B. TWINING, Mang'r, Chicago.
Represented by A. B. STANNARD.

D. McDONALD & CO.,

GAS METER MANUFACTURERS.

(Established 1854.)

51 Lancaster St., Albany, N. Y. 34 & 36 West Monroe St., Chicago, Ill.

STATION METERS, EXPERIMENTAL METERS, METER PROVERS, PRESSURE & VACUUM REGISTERS, PRESSURE GAUGES, ETC.

Also STAR GAS STOVES, RANGES, and HEATING STOVES.

We use only the very best materials, and employ the most skilled labor, and by our long experience (29 years) and personal supervision of every detail, we feel justified in assuring the public that our goods will give perfect satisfaction. Every Meter emanating from our establishment will bear the State Inspector's Badge, and will be fully warranted by us. Our Annual and Calendar will be sent to Gas Companies upon application.

GAS STOVES.

GAS STOVES.

GAS STOVES.

THE GOODWIN GAS STOVE AND METER CO.,

1012-18 Filbert St., Phila., 142 Chambers St., N. Y., 76 Dearborn St., Chicago.

Agents, WALDO BROTHERS, 88 Water Street, Boston.

WM. W. GOODWIN, PRES. & TREAS.
W. H. MERRICK, VICE-PRES.
LEWIS JONES, SEC.
SAMUEL V. MERRICK, SUPT.

SOLE MANUFACTURERS OF THE

G. B. EDWARDS, Mang'r, N. Y.
E. H. B. TWINING, Mang'r, Chicago.
Represented by A. B. STANNARD.

"SUN DIAL" GAS STOVES

The Most Economical, Efficient, and Durable Gas Stove Made.

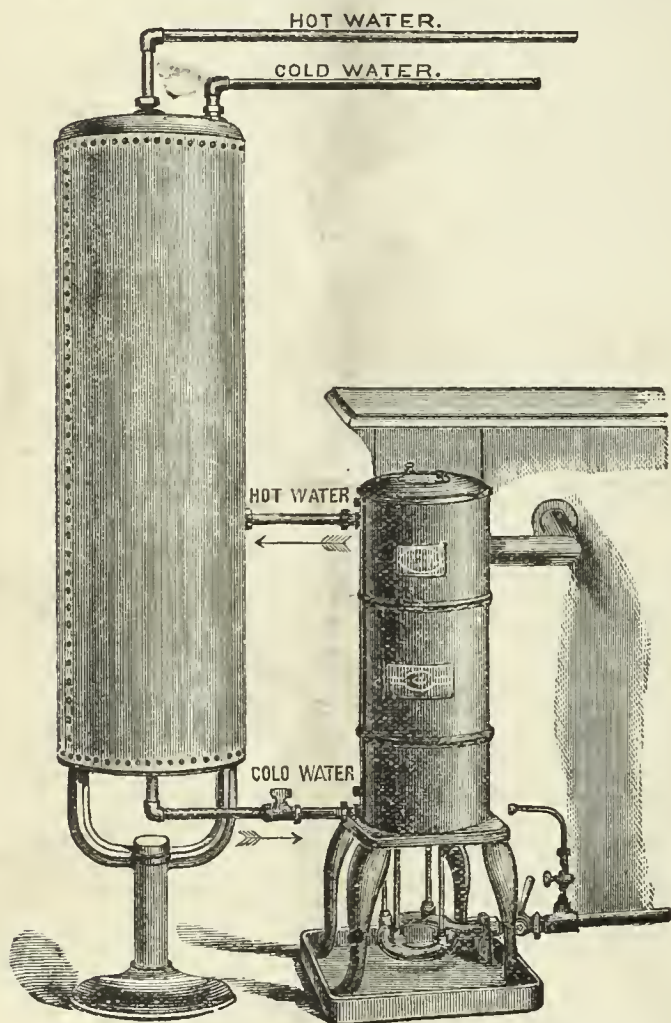

I.—Safety Hot Water Generator and Boiler.

Safety Hot Water Generator and Boiler.

Cut I. represents our Safety Gas Hot Water Generator and Boiler, arranged for home use. This most easy, quick, and economical way of preparing a warm bath, or for heating water for any domestic purpose, entirely supersedes any necessity for the use of ranges or stoves—a great comfort, particularly in hot weather. The boiler being self-filling, as the hot water is drawn off, can never become empty, thus preventing the possibility of any accident.

We beg to call attention to the cast iron pan which is now attached to the legs of the Generator (see illustration). This is to catch the drippings from the Coil, which many persons suppose come from a leak, when in fact they are produced by condensation. This condensation is caused by the hot flame coming in contact with the coil filled with cold water.

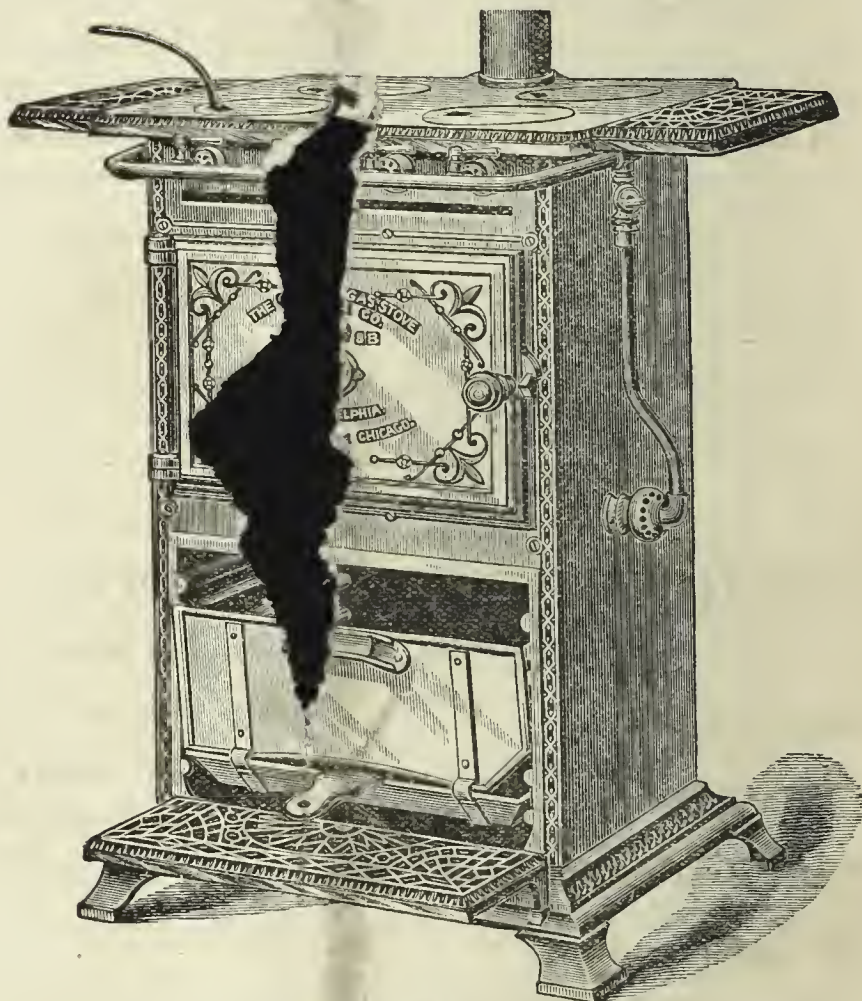

II.—Gas Cooking Stove No. 8 B.

New Style Gas Cooking Stove.

Cut II. represents our New Style Cooking Stove. As will be seen, it has an ornamented cast iron base and front, and extension shelves. The oven burner, which is atmospheric (unless otherwise ordered), is of an entirely new and improved pattern (patent applied for). The ovens are of greater capacity than those of the old style. The top, in conjunction with the outlet pipe, is designed to carry off all products of combustion; hence the outlet pipe must be connected with a flue, or the stove will not work properly.

This Stove has 4 boiling burners in top of hot plate. All fittings are nickel plated. We are making this style of Cooking Stove in the following sizes—viz., No. 7 B, No. 8 B, No. 9 B, and No. 10 B.

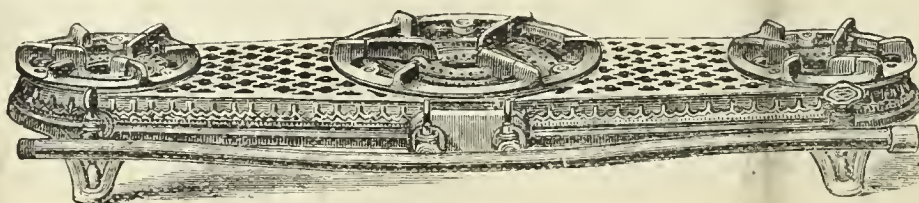

III.—Improved Hot Plate, No. 108.

New Style Hot Plates.

Cut III. represents our New Style of Hot Plates, of which we are making No. 106 (two small boiling burners), No. 107 (two medium sized boiling burners), and No. 108 (two medium and one large boiling burner). See new Catalogue and Price List for further particulars.

THE AMERICAN

GAS LIGHT JOURNAL

REDMAN & KENNY, N. Y.

PUBLISHING OFFICE No. 42 PINE STREET

DEVOTED TO THE INTERESTS OF ILLUMINATION, VENTILATION, WATER SUPPLY AND DISTRIBUTION, & GENERAL SCIENCE.

VOLUME XLVI.—No. 8.
Whole No. 668.

NEW YORK, SATURDAY, APRIL 16, 1887.

\$3 PER ANNUM,
IN ADVANCE.

A. M. CALLENDER & CO., Proprietors. C. E. SANDERSON, Manager.
JOS. R. THOMAS, C.E., Editor. T. J. CUNNINGHAM, Asst. Editor.

ENTERED AT THE POST OFFICE AT NEW YORK, N. Y.
AS SECOND CLASS MATTER.

Published on the 2d and 16th of each month, at No. 42 Pine Street, N. Y.

Terms of Subscription, Including Postage.—For the United States and Canada, \$3 per annum. European countries, \$3.50 (15 shillings—18 francs). All payments to be made in advance. Single copies, 15 cents.

Remittances should be made either by post-office order, registered letter, or bank draft on New York, payable to the order of A. M. Callender & Co.

Correspondence.—Wishing to make this JOURNAL a gazette of intelligent discussion to those of our readers who may wish to gain or give information on the subjects to which its columns are devoted, correspondence is solicited for publication from all who make the study of those subjects a pleasure or a profession.

The American News Company, Nos. 39 and 41 Chambers street, New York, are agents for this JOURNAL. Newsdealers will send orders to them.

[OFFICIAL NOTICE.]

Western Gas Association.

SECRETARY'S OFFICE, QUINCY, ILLS., April 9, 1887.

The Tenth Annual Meeting of the Western Gas Association will be held at St. Louis, Mo., on the 11th, 12th and 13th days of May. The rates at the Southern, fixed upon as the headquarters of the Association, will be \$3 and \$3.50 per day.

The prospects for the best meeting ever held by our Association are all of the most promising nature, save in one important particular. The attendance will surely be large; a flattering number of applications for membership has already been received; the hotel and hall secured by our Local Committee of Arrangements are all that could be desired; the social features of the programme will be a treat such as one seldom enjoys, and yet there is one attraction thus far lacking, although I have not quite abandoned hope that the want in question may yet be supplied. I refer to the paucity of papers so far promised. With each succeeding annual meeting it appears more and more difficult to induce members to prepare essays for our Association's entertainment. I had hoped that I might be able to announce in the next issue of the JOURNAL a satisfactory array of titles, but unless a goodly number of our members at once comes to the rescue, it is only too plain to be seen that I am destined to disappointment. I do not see how I can more strenuously urge the importance of this matter upon the attention of those most interested. Frankly, I am a little disheartened at the apathy displayed in this particular; but, even at this comparatively late day, there is still time to make amends, if our contributors will only settle down to business.

In the matter of reduced railway fares, the intricacies and complications which have been thrown upon the question by the alleged mystifying provisions of the Inter-State Commerce Bill, still remain unraveled, and I fear will remain in this discouraging state beyond the date of our meeting. If, however, a favorable conclusion is reached in time for action, your Secretary will promptly forward the necessary certificate to every member whose name appears upon our roll book.

A. W. LITTLETON, Sec'y.

OBITUARY—JAMES H. WALKER, SR.

Our item columns for March 16th contained a few lines conveying the sad news of the death of Mr. Jas. H. Walker, Sr., whose demise occurred, on the first of that month, at Tonawanda, N. Y., at which place he had some months prior to the end of his busy and eventful life attached himself to the service of the local gas light company. Faithful to his chosen profession to the last, of him it may be said that he literally died in harness. As the subject of this sketch occupied a decidedly prominent position in the ranks of the gas fraternity of this country for many years, and withal was one of those who never sought obtrusively to attract attention to himself, but sought to advance the standing of his art in a quiet and persevering fashion, we believe a short history of his life will be read with interest by his former associates and co-workers.

Jas. H. Walker was born, in 1827, in the pretty Scottish seaport town of Montrose, Forfar county, where he imbibed the rudiments of a com-

CONTENTS.

An Asterisk (*) denotes an illustrated article.

OFFICIAL NOTICE—

Western Gas Association..... 241

EDITORIALS—

Obituary—James H. Walker, Sr..... 241

Death of Mr. H. H. Fish..... 242

Public Lighting in New York City..... 242

Third Annual Meeting of the Ohio Gas Light Association—Official Report—Continued from page 216..... 243

Discussion on the Graeff and Wood Papers—Choked Stand-Pipes: Is There a Remedy? by Nathaniel Kinsman—Discussion—Uniform vs. Special Rates for Gas, by C. M. Converse—Is it Good Policy for Gas Companies to Sell Gas for Stoves, Engines, etc., at a Reduced Price? by W. W. Prichard—Joint Discussion.

The Proposed Massachusetts Law to Regulate the Supply of Electric Light by Gas Companies..... 251

* Otto Gas Engine and Lightfoot Refrigerator..... 252

How to Select Cast Iron Pipe..... 252

Incandescent Lights on High Tension Circuits..... 253

Big Gas Bills Paid on Account of Household Consumption..... 254

ITEMS OF INTEREST FROM VARIOUS LOCALITIES..... 254

Another Decision in Favor of the Owners of the Otto Patents—An Interesting Legal Decision—Public Lighting at Annapolis, Md.—New Haven (Conn.) Gas Supply—The Quality of Omaha (Neb.) Gas—Adding to the Plant—Carthage (N. Y.) to be Lighted by Electricity—Do They Expect to Defeat the General?—Cheaper Gas for Dayton, Ohio—Cheaper Gas for Burlington, Iowa—The Gas Works are Completed—Brisk Coke Trade at Milwaukee, Wis.—Making Sure of Their Position—Cheaper Gas for Middletown, Conn.—Brother Scofield Converts the Council—Munich Benches for the Boston Works—Bartlett, Hayward & Co. Have Plenty of Work—Other Work Being Done by the Consolidated—Changes in the Birmingham (Ala.) Gas Franchise—Changes at Utica, N. Y.—Kentucky Gas Notes—A Brisk Trade—Cheaper Gas for Natick, Mass.—Annual Meeting of the Montreal Gas Company—Will Illinois Have a Gas Commission?—Brought into the Courts—Not so Prosperous—Everything Working Smoothly in Brother Denniston's District—Annual Meeting of the Chesapeake Gas Company—To Rebuild—Troy's New Rate—The Orlando (Fla.) Plant—A Noted Waltham Factory—Street Lighting at White Plains, N. Y.—The Grand Island Gas Company—Electric Light for Dover, N. H.

CORRESPONDENCE—

Piping Rules in Force at Indianapolis, Ind..... 257

The Manufacture of Sulphate of Ammonia from Waste Furnace Gases..... 258

The Market for Gas Securities..... 258

Gas Works Damaged by Fire..... 258

Personal..... 258

mon school education, subsequently taking service with one of the working iron masters with which his birthplace abounded. Coming of age, he decided to try his fortune in North America, and next we find him, in 1848, in Quebec, Canada, where he took part in the erection of the gas works for that city. When the Quebec plant was completed Mr. Walker became interested in the construction of some three or four Canadian gas ventures, subsequently (in 1857) leaving Hamilton, Canada, for the United States, New York city being his first stopping place. He engaged here temporarily with a firm of constructors of gas works apparatus—we are unable to give the names of those who owned the establishment—and shortly thereafter took service, under Mr. J. K. Brick, in the works of the Brooklyn (N. Y.) Gas Light Company. We next find him in Hartford, Conn., superintending the gas works at that point, where he remained until about the close of the War of the Rebellion. Fort Wayne (Ind.) next claimed him as a resident, in which place he had charge, for a time, of the local gas works, but resigned those duties to accept others, which resulted in the formation of the business now conducted under the title of the "Kerr Murray Manufacturing Company." In 1869 the proprietors of the Milwaukee (Wis.) Gas Light Company offered him the position of Engineer and Superintendent to their works, which he accepted. He remained there for something over nine years, during which period his services as a consulting engineer and constructor were in constant requisition. Among the new plants constructed by him about that time were those at Moline, Ills., Sheboygan, Wis., and Winona, Minn. In 1876 he was afflicted with a severe eye disorder, and the medical treatment which he underwent for the relief of that attack laid the foundation for the still graver disorder that finally closed his career. Although far from enjoying even fair physical health, 1881 beheld him in the service of the Citizens Gas Light Company, of Rochester, N. Y., but the pressure of his duties there compelled him, about 1885, to resign the position. Idleness, however, seemed to him to be a greater burden than the depressing effect of sturdy labor, coupled with failing bodily frame, and in September, 1886, we discover him once more in harness as Superintendent of the Tonawanda (N. Y.) works, at which place, as before noted, on March 1st, he calmly surrendered to the fiat of nature. He had been, since the fatal treatment of 1876, a severe sufferer from that most distressing and disheartening of bodily ailments—partial paralysis; but his rare patience and sturdy fortitude during a decade of years afford a key to the character of the man. Deceased was buried in Rochester, N. Y., on March 4th, the ceremonies of interment being in charge of the Scottish Society of that city, of which organization he was a charter member. In fact deceased ever took an ardent and practical interest in the workings of Scottish social and benevolent associations wherever his business pursuits obliged him to locate. The survivors of his immediate family comprise wife, two sons and a daughter, who sorrow greatly for a true husband and an affectionate father.

Deceased was elected to active membership in the American Gas Light Association on the occasion of the second semi-annual meeting held in Cleveland, Ohio, on May 13, 1874, and took a lively interest in the success of that organization. Perhaps one of the most noteworthy papers ever contributed to its sessions was his dissertation on the abolition of Sunday labor in gas works, which was forwarded by him to be read at the meeting held at Brooklyn, in October, 1874. The standpoint taken thereon by the author was somewhat novel to the majority of the fraternity, but its sentiments certainly elicited their hearty commendation. In fact a marked point in the career of deceased was his evident desire to ameliorate as far as possible the condition of those who labored under his supervision. He was a careful and safe engineer, and watched conscientiously over the interests of his employers. Although some claimed or averred that his policy or method was over-conservative, it is nevertheless true that he was among the first of his time to abandon the use of iron retorts in this country. Certainly, he equipped the St. Catherine, Canada, plant with clay retorts in the year 1853.

However, over-conservative or not, accordingly as the fancies or opinions of his contemporaries may sway them, the life of deceased presents a history of earnest labor and modest bearing that will cause all to join in regretting the demise of one who ever practiced as he preached. From an acquaintance with deceased that extended over many years, the writer bears truthful witness to the late Mr. Walker's merit as an engineer and to his worth as a man; and can conscientiously say that among all the billowy marks which cover those who sleep within the precincts of Rochester's resting place for the dead, no one conceals the remains of a truer, kindlier gentleman than that heaped up over what was once the frame of Jas. H. Walker, Sr.

Henry Bower, of Phila., Pa., having failed, it is likely that the five-year contract under which he controls the ammoniacal liquor product of the city gas works will not hold.

DEATH OF MR. H. H. FISH.

We were greatly shocked at the recent fateful intelligence conveying the fact that Mr. H. H. Fish, Treasurer of the Utica (N. Y.) Gas Light Company, had departed this life. Our details of this sad occurrence are quite meager, and simply go to show that his death, which was quite sudden, transpired something over a fortnight ago, it is presumed, at his former home in Utica. Mr. Fish was probably about as well and widely known as any other member of the fraternity in this country, and had been connected with the Utica Gas Light Company as Treasurer, and General Manager, since date of July 1st, 1851. Although well advanced in years, deceased preserved an activity of mind and body superior to many of his contemporaries of lesser age, and his brethren of the fraternity, especially those who counseled with him, will keenly feel his loss. Deceased was admitted to membership in the American Gas Light Association at the third semi-annual meeting, held in Washington, D. C., on May 12th, 1875, and was a faithful attendant at its subsequent gatherings. Communications from his pen often appeared in our columns. We hope at another time to present a short sketch of his life. The following is a copy of the resolutions passed to his memory by his former associates in the management of the Utica Gas Light Company:

"The Trustees of the Utica Gas Light Company, at their meeting held this second day of April, A. D., 1887, note upon the minutes, with profound regret, the death of their Treasurer, H. H. Fish; and to his memory record the fact that the Company has lost an officer to whose energy and ability its success was mainly due; the Trustees a friend and collaborer, whom they loved and admired; the community a man who was respected and esteemed. W. S. DOOLITTLE, Secretary, *pro tem.*

PUBLIC LIGHTING IN NEW YORK CITY.

The Gas Commission, consisting of the Mayor, Controller and Commissioner of Public Works, met in stated session, on March 30th, to open bids and make awards for the public lighting of this city for the ensuing lighting year, which begins on May 1st. With the knowledge that Mr. Wm. R. Grace, our esteemed ex-Mayor, would not have the privilege of awarding a fat slice of the contract to his associates in the electric lighting companies, it was expected that all would not be plain sailing for these hitherto exceptionally "lucky" dispensers of variously-numbered high-power arc lights to the municipality. That expectation was verified in some measure, as the action of the Commission shows. The following bids were made by the gas companies:

Consolidated, \$17.50 per lamp per annum; Mutual, \$17.50; Equitable, \$12; Central, \$28; Northern, \$30; Yonkers, \$30; N. Y. & N. J. Globe (naphtha), \$25. Awards, at the bids, were made to the four companies at top of list—the Equitable folks being authorized to maintain all public lights reached by their mains. In round numbers these approach a total of 2,500 lamps. The Yonkers, Northern, and Globe proposals were referred to a future meeting, which takes place to-day (April 14th). The Globe Company now maintains about 120 naphtha lanterns in what is known as the Woodlawn district, and the contract will probably be renewed at the bid price of \$25 each, which rate has prevailed for the service for some years. It is surmised that the Northern and Yonkers Companies will, in compliance with the Mayor's suggestion for a reduced rate, reduce their bid slightly, say, to \$29 per lamp; but in consideration of the peculiar circumstances attending the public lighting supply conditions in their respective districts, we think the \$30 proposition is not at all unreasonable.

The bids submitted by the electricians were somewhat different to those which prevailed during the Grace *regime*. Hitherto the Brush and the United States Electric Light Companies worked in harmony, in that they divided the city between them. Fourteenth street, running east and west, constituted the dividing line, the Brush folks taking the northern and the United States the southern division of the territory; and while that arrangement was not disturbed this year, the bids were slightly diminished, as also, at least by the United States Company, the candle power. The United States asked 65 cents per night for lights of 1,000-candle power, but the Brush people stuck to the 2,000-candle farce, at a price similar to that of the first named Company. Ever since the electrical promoters managed to secure a grip on the treasury of the city they have received 70 cents per light per night, or a yearly payment of \$255.50 for every public arc maintained; but Mayor Hewitt seems disinclined to grant them their former privilege, and their proposals were held over until the meeting set for to-day. This will occur at too late an hour to permit us to report the result in our present issue. The United States proposition seems to us—if there is any merit at all in the way in which electric arc lighting value is "determined"—to be of the decidedly "cheeky" order. Even the city of Brooklyn, where the electric lighting is under control of the staunchest and most prominent of the political ring in power at that point, obtains 1,000-candle power arcs at the rate of 50 cents each per night. Again, the North New York Lighting Company, at the March meeting of the Commission, offered to supply (in the Harlem section) 2,000-candle power arcs for 55 cents each per night; while the Harlem Lighting Company offered to furnish similar service at 48 cents. The last named Company also offered to supply 16-candle power incandescent lamps, provided the present gas lamp posts could be used as supports, at the rate of 5 cents each per night. All the electric bids were referred. We will, in our next, state the final outcome.

[OFFICIAL REPORT—Continued from page 216.]

Third Annual Meeting of the Ohio Gas Light Association.

HELD AT THE BECKEL HOUSE, DAYTON, OHIO, MARCH 16 AND 17, 1887.

FIRST DAY—AFTERNOON SESSION.

*Discussion on the Graeff and Wood Papers.**

The President—You have heard two papers upon the same subject which do not differ greatly in their sentiments. We would like to have them thoroughly discussed.

Mr. Jones—I suppose, since all here seem to be practical men, that neither theory nor faith will amount to much. What we do want, however, is experience. I understood Mr. Wood to say that they have operated an electric plant in connection with the gas works at Sandusky for a year. I would like to know what has been the result, as to profits and success. In smaller places, for example in Middletown, I understand that the electric lighting of the streets costs the city \$5,000 per annum. It is done by an independent electric light company. On that basis, I am assured by a stockholder in the electric company, the scheme does not pay at all. I disremember the number of lights maintained.

The President—Will Mr. Wood tell us whether it paid or not. From the tone of his paper I should infer an affirmative reply.

Mr. Wood—I will not say how well it paid; but our directors are all very well satisfied, as are the stockholders and myself.

Mr. Jones—The two paid in combination?

Mr. Wood—Yes; paid better than would have been the case if the electric light had been put in in opposition to the gas company.

Mr. Huntington—Was your charter amended so as to enable the gas company to furnish the electric light?

Mr. Wood—The electric lighting portion of the Sandusky Gas Company's business is conducted by a separate organization, but the stockholders in the former are also stockholders in the latter.

Mr. Graeff—I would like to ask Mr. Wood how many arcs are supplied?

Mr. Wood—About 100.

Mr. Graeff—And the stockholders reap a profit?

Mr. Wood—We have not yet run any one month when the profit earned did not amount to —† per cent. per annum.

The President—Mr. Wood's reply certainly shows that electric lighting can be done at a profit in Sandusky.

Mr. Ramsdell—I would like to ask Mr. Wood what price his Company receives for each arc light.

Mr. Wood—Each single commercial lamp burning until ten o'clock is paid for at the rate of \$35 per month; \$40 is charged for those that are extinguished at midnight. We receive \$90 per annum from the city for each street light maintained in accordance with what is known as the Philadelphia schedule. I may also say that we are still under contract to light the city with gas, which contract does not expire until August next. The public arc lights mentioned are all in the districts formerly lighted by gasoline, therefore a clear gain. We would not have got those if we had not adopted the combined plan.

Mr. Dickey—I would like to inquire as to the cost of the posts described in the paper.

Mr. Wood—We make them ourselves; they cost us \$7 each.

Mr. Jones—How did the introduction of electricity affect your gas output? Was the latter increased or diminished?

Mr. Wood—The total sendout showed a very slight increase. I call it virtually the same. The electric light is an addition. Of course we look for an increased sendout of gas next year.

Mr. Light—Did I understand that you got \$90 per year for each public arc light?

Mr. Wood—Yes; running until midnight. The circuit in the former gasoline district was a very long one, and we got a favorable contract, to last for three years, on that account.

Mr. Bushnell—Springfield has had an electric lighting plant for something over three years, and about 56 public and 50 commercial lamps are supplied by it. The charge for each street lamp is \$130 per annum. They are lighted 30 minutes after sunset and extinguished 30 minutes before sunrise every night in the year. We (the Springfield Gas Company) are required to maintain our gas lamps during similar intervals, which means an annual lighting duty of 3,750 hours. The electricians displaced about 200 gas lamps, or not quite 4 posts to an arc light, which shows that we, with gas, charged but \$80 per annum for lighting a section now lighted by electricity at an annual cost of \$130. That proves there is no

particular economy to the city in the electric light. For the commercial lights they charge \$12.50 per month. The proprietors of the Springfield Electric Light Company have not been so successful in the item of profit as Mr. Wood's Company has been, because they desired this year to sell out to the Springfield Gas Company, for the reason that electric lighting did not pay them a profit. We did not buy, but they have now made a new contract, which they think is more favorable than the old one, with the city, and they will increase the number of lights, provided the City Council think it proper to do so. The consumption of gas has increased somewhat since the introduction of the electric light; but I think we would have now had a considerably larger consumption, by reason of the natural or normal increase, if an electric light company had not been organized in our city. Our authorities have adopted a different plan from that spoken of by Mr. Wood—I mean as to extending the electric light out into the outskirts of the city. Our authorities only put the electric light in the business portion of the city, and require the Gas Company to extend mains to and put up posts in the suburbs—not a very desirable thing for us. They have required us, or under our contract may again require us, to extend mains and erect posts out beyond the line of electric lights, so that this has given us the same number of lights that we had originally; perhaps a few more. However, as Mr. Wood stated in his paper, the street lighting is not very much of an object to a gas company, for I think the profit therein is very small. The directors of our Company, when the proposition was made to combine the electric light plant with the gas plant, took a rather different view from that expressed by the gentleman who read the first paper. Our folks thought that if they controlled the two systems of lighting the cry of monopoly would at once be heard, and they would have the same trouble that they had before; therefore, they preferred, at this time, not to join the two together. I am glad we have been enlightened to some extent in this matter by these two papers. I think I entertain somewhat similar views to those advanced in them. In our place, as soon as it should become known that the electric light company was controlled by the same parties who controlled the Gas Company, there would be the same dissatisfaction, and the same desire to organize a new company—either a new gas company or a new electric light company; and our directors thought it would be better to compete with one company than with two or three—especially so when the present electric light company is in the hands of our own citizens, with whom we are friendly. It is better for the Springfield Gas Company to have it run in that way than to seek to unite the two interests; at least that is the way we feel about it. We may be wrong in our interpretation of the idea, but such is the conclusion of our board. Our contract prices for the next five years having been fixed, we feel very comfortable as to the outlook for that period, although our gas plant does not make the profit that Mr. Wood reaps on the electric light plant at Sandusky. In fact we cannot come anywhere near it. We get a little more for gas in Springfield than they do in some other cities; but, taking the population and output into consideration, I think we are furnishing gas very cheaply. It may be of interest to you to know that the price of gas is fixed for the next five years at \$1.50 per thousand cubic feet. That is the price charged to private consumers, and also to the city outside of the city limits proper. For street lamps the price is about the same as in Dayton—\$20 per post, burning all night and every night; but we do not consider that there is very much profit in that.

Mr. Bierce—What is your population; and what is the output of gas?

Mr. Bushnell—Our population is about 35,000, and the annual output (as I remember it) is about 45 millions cubic feet. I am sorry I cannot say anything that would be of particular interest to you on this subject of combining and operating the two plants (gas and electric) in common. We are getting along in a very friendly way with our competitors, and if they do not attempt to crowd on the incandescent light for street lighting, we shall have no reason to complain. As far as I can understand, from observation and report, they have not been very successful in other places in attempting to light streets by the incandescent method.

Mr. Dickey—Does your contract extend for five years with the street lamps as well as the others?

Mr. Bushnell—No; it does not. The gas rate is fixed by ordinance; but the contract for street lighting is made from year to year, still the price is fixed so that if any additional lamps are used there is no question about the rate of payment for them, and there is no coming up of the question as to a change of price. The all-round price is fixed for a term of five years; and in the matter of supply to private consumers, that practically amounts to a contract by the Company that it shall not charge a higher sum during the period agreed upon.

Mr. Dickey—That has been recently fixed?

Mr. Bushnell—Yes; within the last two or three months. Various propositions were made to our City Council in regard to lighting the

* For Papers, see issue April 2, 1887.

† Mr. Wood named the figure, but desired that the same be not published.

streets; but after considering them all they concluded they had better continue the contract with the old company. We made the contract, and they fixed the price.

The President—I think Mr. Gwynne can tell us something about electric lighting.

Mr. Gwynne—I have had very little experience in that line. We have an opposition or electric company in our town; but we have had nothing to do with it in any way, shape or manner. They are simply a rival company.

Mr. Wood—You ought to “stand in” with them.

Mr. Gwynne—I have at times felt that I would like to “stand in” with them.

Mr. Graeff—If you want some figures on this subject I can give them to you, but without naming the writer.

The President—You will vouch for their authenticity, I suppose?

Mr. Graeff—I will mention the name of the writer, if you will agree that it shall not appear in the report. It was a name read this morning in answer to an invitation to attend this meeting. He is connected with a Gas Company now running an electric lighting plant. The letter was written to me March 3d. He says: “The plant was started about the 1st of December, 1885, so that we have now been running a little over a year. Last spring, about the 1st of April, we had 34 lights, and we now have 60; and for the year ending the 1st of April we shall more than pay running expenses, but not enough to make the Company whole of its investment.” The way he figures running expenses is as follows: “I estimate that when we can clear 16 per cent. on the actual capital invested above the running expenses, that we shall lose no money. That 16 per cent. I divide as follows: 6 per cent. for interest, 8 per cent. for depreciation, and 2 per cent. for office expenses; and, at the prices that are charged here, that amount of money can be made (at least I think it can) when we have 80 or 90 lights. We run by water power, paying \$1,000 per year for power sufficient to drive 70 divided arc lights of the T.-H. pattern. I employ one man who runs the dynamos, and who makes the extensions of wire, repair of lamps, etc., and a young man who takes care of carbonizing these lamps. The total cost for labor is about \$1,150 per year. The average receipts for lamps is \$75 each. The dynamos are stopped at 12 o'clock each night.” He anticipates that he can increase the number of lamps without additional expense. When he adds ten more lamps, which he has the present capacity to do, as regards power and labor, he will add \$750 to his receipts with very little increased expense except the cost of the additional carbons. He says he nets 16 per cent. on the actual capital invested; paying 6 per cent. on his investment as interest, he will clear, at the lowest calculation, 10 per cent. more than that, and allow a little extra for extra depreciation. That is the report from a good, solid gas works in an Eastern State. I think if Col. Stedman were here he would give you some more instances of the same kind. I had the pleasure of going over some figures with the Colonel, in connection with the President of his new company, and if he were here he would have figures to present to you; but he might consider it a breach of confidence if I gave those figures without authority. I would like to say, before this discussion closes, that at the last October meeting, in speaking of incandescent lighting, the superintendent of a gas works in a Pennsylvania town who has been competing with the Edison incandescent lamp for about two years, told me that they were now lighting the streets with the Edison incandescent, and that his output had been decreased one-third in consequence of his fight with the incandescent lamps. That is the only case of which I positively know where a gas company has directly lost in output by reason of such competition.

The President—Do you know what the price of gas was?

Mr. Graeff—I cannot say, but I do not think that it was too high. He lowered the price of gas. I know he introduced the Albo-carbon lights in a great many cases without making any charge for them. After doing everything in his power to hold up his end of the fight he told me, last October, the result had been that he had lost one-third of his output. That is a matter, I think, for serious consideration. I will say, however, in all that I have heard and seen of the system, his was the only case of that kind which came to my knowledge.

Mr. Bushnell—Did you mention the cost of a plant for 50 lights?

Mr. Graeff—I did not; I have not got the cost. I said the cost of the water power in this instance was \$1,000 per year, and of the labor, \$1,150 per year; but that gave a capacity for fully ten more lamps than they have. Further, that with the lamps at present in use the Company had paid expenses.

Mr. Bushnell—They had a great advantage in having water power.

Mr. Graeff—Certainly, they had an advantage there; but they had the disadvantage of running a smaller number of lights than their capacity warranted.

The President—I think Mr. Coverdale can give us some information.

Mr. Coverdale—I do not know that what I can say about the subject treated of in those papers will interest you; but I believe every gas company in the country will sooner or later have trouble from the competition of electric light, and had better prepare themselves for it. I was much annoyed last year by opposition directed against a gas works owned by me at Rome, Ga. First of all the water gas agitators stirred me up. They said to the citizens they could make gas for about 18 cents per thousand; that they could put up water gas works and, by means of a separate main, furnish gas for fuel cheaper than natural gas; and that they could supply gas for illumination a good deal cheaper than we could furnish coal gas. I succeeded, without any great effort, in spoiling their game; but when it came to the electric light I encountered quite a different thing. Our contract with the city does not expire for nine months, but the authorities decided to annex an outlying village, thus adding another ward to the city. The villagers were told that their streets would be lighted by gas, but it would require us to lay a mile of pipe in order that the place might be lighted. About 20 lamp posts would be fed from that new line. The electricians then came before the Council and said: “We will light up that little village with electric light, which will give you five times as much light as you can get from gas (at less cost, too) on condition that you pay us \$120 per annum for each arc, and then contract with us to light the rest of the city with arcs. Twenty of these will do the work, and the city will be far better illuminated than it is at present with gas, and at no greater expense.” I failed to understand that, of course; and I went right down to Selma, Ala.—not a great way off—for information on the subject. The Superintendent of the Selma gas works (he is a member of this Association) said: “We have now got 37 arc lights, and they formerly paid us \$2,688 per annum for 112 gas lamps; but now they pay us \$3,700 for the arc lights, and \$900 for gas lamps”—it costs Selma about twice as much to light up the town as when they used gas—“but,” he added, “they cannot get along without it, for we will get about 20 additional lamps next month, because they are going to increase the lighting area once more.” I did not want to propose to put in a plant to light up the new Fourth ward in Rome, and I did not want to say anything about putting in a plant to light our city. I thought the less said on that score the better for us; but I wrote to several places where they were using the arc light for street lighting—I did not write either to the gas companies or the electric light companies, but communicated with the property owners of the various places—and received replies from every one. There was not a single reply that favored lighting with the electric light. In fact all were indicative of dissatisfaction with the light. Of course, I laid those letters before the City Council. Last night (March 15) was the date set to determine whether the city would be lit by electricity or by gas. At the meeting I made a proposition to light up the streets with gas, if they would give us a three-years' contract—we now have 88 lamp posts, and are paid \$2,400 per year for them—and increase the number of posts to 125, for the sum of \$26 per post per year. I agreed to lay one mile of pipe to the Fourth Ward, and to put up lamp posts on every 210 feet on that new line of pipe. The electric light folks were first heard by the Council, but we succeeded (not exactly in defeating) in inducing them to withdraw their proposition. Then our proposal came up before the Council; and I am pleased to tell you that our terms were acceded to. We now have the contract.

Mr. Allison—Perhaps Mr. Coverdale, before he gets through with the contract, may meet with an experience similar to mine. Do you light and extinguish the lamps?

Mr. Coverdale—Yes.

Mr. Allison—Last December the Xenia City Council passed a resolution asking for the better lighting of our city. They had been using arc lights for five years, starting them in January, 1880. The citizens, however, became so dissatisfied that they asked the Council to see if the city could not be better lighted. I made a proposition about a month ago on behalf of the Xenia Gas Company, which was accepted by nine of the twelve members of the Council, and the City Solicitor was directed to draw up a contract in accordance with its terms. One of the three who voted against it—being a pretty old sore head, and who was, in fact, instrumental in determining the Council when the electric light was originally put in—succeeded in inducing a Common Pleas Judge to sit down on the City Council by forbidding them to carry out the new contract. Perhaps Mr. Coverdale may have the same experience before he gets through. The case will come before the Court on Monday, March 21st, for possible final settlement. I do not like the looks of it, and I do not know what the result will be, because the gas company is forbidden even to be a party to the suit. It is in reality an attempt to prevent the President and Clerk of the Council from signing the contract.

Mr. Coverdale—Perhaps I ought to add to what I have said about the

electric light at Selma, that I have a letter which states the cost of the plant used to light up that city was about \$15,000. They borrowed \$15,000 to pay for it, but the writer of the letter is satisfied, as he assured me, that they can pay the current interest on their investment, and get their \$15,000 back again out of the earnings of the electric light supplied within a period of six years. Let me tell you about another gas company in which I own some stock. Before the advent of the electric light in the town referred to I got a 10 per cent. dividend. The electric light folks have been there for three years, and since their appearance my dividend return has been 4 per cent.

Mr. Light—What does that electric light company get per lamp?

Mr. Coverdale—\$90 per year.

Mr. Alexander—An electric light plant has been located in the town of Painesville during the past year. It was introduced by a company entitled "The Globe Electric Lighting Company, of Bucyrus, Ohio," but they seemed to have dropped out of it, for it has passed back into the hands of the Western Electric Light Company. They have 55 arc lights on the streets, in consequence of a contract for one year with the city, made when they put up the plant, for which they were to get \$6 per month per light. Two weeks ago the Common Council renewed that contract for another year. When the plant was put in the owners offered to sell it to the city for \$13,500. They had an engine, but no boiler. They bought their steam from a manufacturing establishment. Their income from the 55 lamps, at \$72 each, is \$3,960 per year. I have tried to find out what their running expenses would be, and secured my information from many sources. To start with, they paid \$1,400 for steam. They had a building (put up by a man who owned the lot next to a manufacturing establishment) for which they pay \$150 per year rent. Their carbons cost about \$450 per year; superintendent, \$360; engineer, \$540; carbon man, \$360; for oil and waste, \$40; for globes broken during the year, \$40; and as they had not lived in Ohio long enough to know how to fix their tax bills, they paid \$275 on that account, making a total of \$2,615 per year; not including any extraordinary repairs. That would leave them a profit of \$345 per year on what they claim is an investment of \$13,000.

The President—We have a good many meter men in our assembly, and we are curious to hear what they can say in favor of electric lighting. We would be glad to hear from Mr. McDonald.

Mr. McDonald—I do not know why the President should call upon a meter man to discuss this subject. We do not measure it; therefore we oppose it. I think, however, from what I have gathered at the different meetings which I have attended (I was at the Boston meeting of the New England Association last month) and from general conversation with gas men, that there is money in electric lighting, when the business is handled by a gas company. I think I can say so with some degree of confidence. As to whether it is always policy for a gas company to undertake to run an electric plant, I do not presume to judge. Some say yes to that; but others say no. We have heard this afternoon from two very good representatives of these two opinions—Mr. Wood who, read the paper, and Mr. Bushnell from Springfield. I have about come to the conclusion that the electric lighting business is something gas companies cannot afford to laugh at. They must consider it carefully and seriously. Electric lighting, as many have already said, has come to stay; and I think the day is coming when the incandescent light will be the great competitor of gas lighting. I do not believe that gas companies have very much to fear from the arc light competition with their business—at least, not for house or store purposes. My experience in our city (Albany, N. Y.) is that the arc light is always removed from a store after being in for a time. We have had the commercial electric light for five or six years; but find that it does not stay long in any one place. It changes constantly. They have a few customers, but these keep changing all the time. For street purposes, however, it seems to be a permanency. The incandescent light in my opinion is the coming factor in the lighting business. I begin to hear stories to the effect that the incandescent light can be produced at a very low figure. We heard those stories a number of years ago about the arc light, and were loth to believe them; but still it has come to the fact that more light, candle for candle, can be produced by electricity than can be produced out of the coal when made into gas. I can only say I think it wise to consider the matter carefully, to look into the electric lighting business, and thus make up your minds whether you want to go into it or not.

Mr. Gwynne—I would like to ask Mr. Graeff a question. He speaks of a gas company in Pennsylvania losing one-third of its business by reason of the introduction of the incandescent light. Does he know at what price the incandescent light was furnished?

Mr. Graeff—I do not. The Edison Company went in there and made a strong fight, which lasted for two years. I do not care to mention the

name of the company, because the Superintendent might not like it; but I will tell the name to any one who desires after the meeting is adjourned. It was not given to me as a secret, but still I would not like to advertise the fact. He said it was seriously hurting him, and he gave that as the extent. I have not heard what the Edison incandescent light is being furnished at, but it is supplied at a very low figure, I am confident. They also claim to be paying expenses; and, not only so, but I think the Gas Company admits that the Edison Company is not losing money. It is my impression that they so believe.

Mr. Converse—I would like to hear from Mr. Bates on that point.

The President—Mr. Bates is present at the meeting, but I do not see him in the room. We would like to hear from Mr. Printz, of Zanesville.

Mr. Printz—I do not know that I can give any information on the subject. We have in our place at present about 90 arc lights, furnished under the system of the Western Electric Light Company, of Chicago—64 commercial lights, and probably 26 street lights. They receive \$80 per year (lighting by the moon schedule,) for street lights; for store lights, burning until twelve o'clock, they get \$25 for one light, or \$23 for two lights. They allow a discount for those that are cut off earlier in the evening. At present they do not appear to, and do not claim to be making any money. They think they could, or say they could, if they got an increased number of lights. They claim that their plant is sufficient to supply 50 or 60 more lights than they are now running; and that the additional expense would be very little. The company have several times spoken to our people about taking the plant off their hands; and we have thought something about it. In the first place, we thought if we allowed this company to come in and establish the price, as they have done, the same feeling would not be caused as if the Gas Company took hold of it originally. Whatever price was fixed for the light by the electric light company could be maintained, if we saw fit afterwards to purchase the plant, and if the after circumstances would permit us to reduce the price a little we might thus secure the better feeling of the people. We have not yet come to a conclusion to do it.

The President—We would like to hear from Mr. Padan, of Portsmouth.

Mr. Padan—We have at Portsmouth a different kind of competition from any that I have heard spoken of. I think that Portsmouth is perhaps the best and cheapest lighted city in the State of Ohio. If other gas companies will meet such a competition as we did there, they had better look into the matter of going into the business themselves. The city does its own electric lighting. They utilize the water works, and have no engineer to pay. I think the plant cost \$18,000. They claim that the expense of operating it, to obtain 96 arc lights, is but \$3,000 per annum. They get \$800 from the railroad. Last year we got \$5,000 for lighting the city. The electric light is much superior to the gas light. I have heard a great many from other cities or towns say that they did not like the electric light; but that is not the case in Portsmouth.

The President—Did the water works pay interest on the investment since they run the electric light?

Mr. Padan—The water works never paid. They did not earn enough to pay interest on their own bonds.

Mr. Printz—I might say further, while the 64 commercial lights placed in our city have decreased our consumption in those particular stores, our increase of consumption in other directions has been considerable. Whether it is owing to the education of our people to the use of more light or not I cannot say; but we certainly have had a considerable increase in the consumption of gas. Our gas rate is \$1.30; and that low figure may have had something to do with this increased consumption.

The President—We would like to hear from Mr. Ramsdell.

Mr. Ramsdell—Whatever electric street lighting is done at Vincennes is accomplished by the incandescent method. Our Company's contract with the city extends for a number of years yet, and the district supplied by the electric light people surrounds that embraced in our contract—commencing at the river and going around the city. Our city is pretty well lighted. We tried to do all that we could for the electric light people, and gave them all the corners that we did not have, so that the place is now very liberally supplied with lamps. For street lighting, however, the incandescent lamp is not a success; in fact it is very poor. The incandescent lamp used in Vincennes gives out a light which in no respect resembles a gas light. In color and intensity it very much resembles a little arc light. The filament gives out quickly. The lamps are guaranteed by the makers to run 600 hours, but I do not believe that they have ever had one which lasted that long. I have known lamps to be changed twice in the same month. When they are first put up they give a very pretty light. Being bright and brilliant, they look very nice; but in a very short time they begin to go down, more or less rapidly, changing to a reddish color, and finally flicker out entirely. Our

City Councilmen are rather friendly to the electric light people, and the rule requiring the police to report any lamps that might happen to be accidentally extinguished is strictly lived up to in regard to the Gas Company, while the electric folks are not so promptly looked after. One of their loops may be but a ghost of what it ought to be, still, if it is not entirely dark, it is not reported. We only ask for fair play in the matter. The stock of the company is owned and controlled by Vincennes citizens, and we do not do anything at all to antagonize them. We have no fear from the competition in our city. Our consumption has increased very materially; and I think that that increase is largely due to the reduction in price. At the same time we think that the electric light has helped our business. We know that it has, in some instances. As to the matter of price, which has been spoken of here, I think that is a very great consideration when we are talking about the electric light. I know, in our city, electric light is supplied at all sorts of prices. It would ruin our business if we undertook to do business on the same principle. They put in their lamps wherever they could, and got what they could for them, in very many cases. They started last October, and I do not think they have five lamps more to-day than they had when they started, which is a pretty severe criticism on the system.

Mr. Dickey—What system are they running?

Mr. Ramsdell—The Heisler, of St. Louis, Mo. In some respects it is very good, while in others it has very serious defects. They get \$2 per month, or \$24 per year per light, for street lights.

Mr. Dickey—It is not equal to the Edison?

Mr. Ramsdell—No; I do not think so; but perhaps I am not competent to judge.

Mr. Bushnell—I would like to ask Mr. Ramsdell how the prices compare as between electric and gas light, in the matter of street lamps.

Mr. Ramsdell—We have an unusually favorable contract with the authorities in respect of street lighting; perhaps some might consider we get a pretty high figure.

Mr. Padan—For how long is that contract to exist?

Mr. Ramsdell—It runs until 1900.

Mr. Gwynne—I have listened with a good deal of interest to what has been said on this subject. A plant was put in our place (Fostoria) a year ago last November. It so happened that it fell into the hands of the manager of the telephone exchange; but as he had no money with which to run it we made up our minds that the opposition would be unimportant, and, for that reason, we paid very little attention to it. In order to get a foothold he visited our best consumers, and offered to let them try the light for 30 days, with the understanding that if the service was satisfactory they were to pay a certain price—which rate was very irregular. As far as I could find out, if two lights were used in one place the price was \$12, other parties using two lights were charged \$14, and still others paid \$18 for a like service. Those who did not readily yield to his proposals, in cases where he thought consent would be particularly harmful to the gas company, the lights were offered for little or nothing. Inside of 30 days he got orders for 21 lights, and took from the gas company consumers whose bills for gas each year would amount to \$1,000. At the expiration of the trial month none of the lights were discontinued; but after that the service ran down somewhat, and three of the 21 came back to the gas company. We had no contract with the city for any specified time, and he eventually asked the Council to contract with him for nine public lights (his dynamo could support a total of 30 lights), and they authorized him to do the work for one year. The lights were to be extinguished at midnight; the total sum to be paid for the work was fixed at \$900. The service has been indifferently performed, and the contract time will shortly expire; but he now proposes to do business on a larger scale, having recently asked the Council to contract for 32 lights (on a three years' agreement), at the rate of \$75 per light per annum. If successful in this he will succeed in cutting out of our district an area which we hitherto have lighted by gas. A friend informed me that this genius now proposes to supply the incandescent light, and so far in his canvass has succeeded in obtaining orders for upward of 200 incandescent burners. Such has been our experience with the electric light. I believe he is backed by the home managers of the Brush Electric Light Company, who, I believe, wish to force us to buy him out.

Mr. Bushnell—It is very evident that the Fostoria electrical branch does not pay any return to those interested in it.

Mr. Gwynne—I do not think it does.

Mr. Critchlow—Following up the remarks of Mr. Graeff about the incandescent light, I will refer to a case not far from the eastern line of Ohio (it may bring to your mind a point worth considering) where the Westinghouse Company put in 800 16 candle-power incandescent lights; and in order to get consumers the lights were placed at the rate of 35 and 40 cents each per month. This resulted in taking away from the gas

company about \$4,000 per annum. The price of gas was immediately reduced from \$2 to \$1.50 per thousand. The electric promoters did not succeed in subsequently increasing the price for their light; and having started in at too low a figure, they soon ran behind; but, however, that did not prevent the cutting down of the gas company's receipts. The competition finally resulted in the purchase by the gas company of a controlling interest in the stock of the electric light plant, at the figure of \$22.50 per share. These shares cost \$50 each one year ago.

Mr. Christian—We at Norwalk have had quite a little experience in this direction. The same people who introduced the electric light at Painesville and Sandusky appeared before our City Council and succeeded in securing a contract (to last five years) for public lighting at the rate of \$72 per year per lamp. With that as inducement they thought to organize a stock company and place a certain amount of stock among our citizens. Failing in that they put in the plant on their own account, fitting it out with three 30 and one 25 light dynamos and a 125 horse power engine. They started up in December, 1886, and managed to shake down their foundation in about a week's time. Then they stopped to make repairs, the city in the meantime authorizing the gas company to furnish gas for public lighting until repairs were completed. In 20 days they renewed operations, and have been running since, with the exception of one night when the lamps were out for about 45 minutes. They started in with 64 public and 22 commercial lights—I wish to say I think their light is as good as any that I have seen; but of course a good light is a certainty where plenty of power is supplied—but of the latter class only 11 were left, and of these they get paid for only four. The cause of the shrinkage in the commercial class was the expense. I do not think that constitutes a very good showing for an electric light company. I have looked into the cost of running that plant. Their labor account is very low (their superintendent is a councilman, who has not had much else to do for some years), and may average \$2,500 or \$3,000 per year. Recently I inquired of their coal merchant as to the probable quantity of coal he sold them—remember that they have a total of 75 lights in circuit—and from his reply I judged their coal bills represented about one-half of their income. It seems to me they were using up about two-horse power for each light; therefore, under the circumstances, the lights ought to be brilliant. Putting these things together I estimate that their annual expenditure for salaries, coal, taxes, repairs, etc., cannot be less than \$5,000, and their receipts are, if anything, a trifle under that figure. I am certain they cannot figure out a single dollar of profit on the operation. The great idea with them was to get a footing in the town; and to compass that end they placed their prices at so low a figure as to preclude a profit on the investment. The gas company has no money to devote to the purchase of this plant, and be obliged to continue the losing contracts made by the promoters of the electric light company. Further, sooner or later they will have to give the task up, when, if we desire to purchase their property, we can do so on our own terms. No doubt we could do the work cheaper than it could be done by them. I think one great point has been overlooked in regard to gas. The results attained in electric lighting supply have been very great. If we may believe what we are told I think they claim to realize 90 per cent. of the power energy developed, and that not over 10 per cent. of the 90 is lost in the current transmission. Now, from our working standpoint we cannot begin to realize equal results, but it is nevertheless true that there must be a wide margin for improvement in the methods for consuming gas. See what a rapid advance has been made by the Lungren lamp, which, instead of 5 candles, enables us to secure 13 candles per cubic foot of gas consumed. It seems to me it will some day be possible to burn gas on the incandescent principle, and then we will surely get results superior to any yet attained. We ought to be able to secure temperature and effect equal to those attained in the incandescent light; and with that advance scored, we could count on decreasing the consumption of gas, per unit of light, by full 50 per cent. That would be equal to reducing your selling rate to 75 cents per thousand, provided your present rate was \$1.50. Thinking of this possibility, and remembering that the electricians have about reached the highest attainable results under their mode of manufacturing the currents, not forgetting either that in the transmission of the current an increase of lighting intensity is only gained at a sacrifice in the life of their lamps, it seems to me that the future of the gas industry affords anything but a gloomy prospect.

Mr. Gemuender—I would like to ask someone interested in the joint supply of gas and electricity whether his profit in electric lighting has been gained at a sacrifice of his gas profit?

Mr. Wood—The profit in electric lighting at Sandusky has been clear gain.

Mr. Gemuender—What do you say about the gas?

Mr. Wood—Our companies—that is, gas and electric—have separate

organizations, with separate accounts. The only thing in common is the supervision.

The President—This has been a very interesting discussion, but we have probably devoted as much time to the subject as we can spare.

On motion of Mr. Huntington, a vote of thanks was tendered to Messrs. Graeff and Wood.

Mr. Nathaniel Kinsman, of Springfield, Ohio, read the following paper, entitled—

CHOKED STAND-PIPES: IS THERE A REMEDY?

Gentlemen of the Ohio Association:—Having promised our Secretary that I would give my views on choked stand-pipes, and attempt to suggest a remedy therefor, let me say that I had no trouble in finding plenty of "chokes;" but the discovery of a "remedy" is quite another thing. I know of but one way in which to prevent stand-pipes from choking, which is to run at low heats; but that is what no one is willing to do. During my experience of 30 years I have failed to see the stand-pipe that would not, at some period or another in its use, become choked; and I believe that so long as we run at high heats we will be troubled from this cause.

At one time, like a great many others, I thought if larger pipes were used a good effect might follow; but when, in our new plant at Springfield, we put in six-inch stand-pipes, I failed to observe any improvement over the old rule. Working under high heats a six-inch pipe will choke up as quickly as a four-inch one. Looking over the field I fail to be able to prescribe a remedy; but, failing a remedy, I may tell you how we clean out the "chokes" at Springfield. We use a bar of iron, two inches square, pointed at the end. Having heated the bar to as high a temperature as possible, we remove the stop and insert the bar. By turning the latter around the interior of the pipe a few times the tar is melted, and the pipe is speedily cleared. When the tarry deposit is burned so hard that the simple application of the bar will not start it, with the pointed end of the iron we work a small hole through the obstruction, then, allowing the stop to remain off, and not charging the retort, in two or three hours the pipe is cleared.

Discussion.

The President—Here is a question that we can all discuss. No man that has been long in the gas business can say he has had no experience with choked stand-pipes. I shall not think it necessary to call upon any one in particular to give experience in this matter.

Mr. Ross—I had too great an experience with choked stand-pipes a few years ago; but I now scarcely ever have a choked stand-pipe—certainly not over half a dozen in a year. The only change I made was to fix a device at the end of my hydraulic main, which permitted the tar to run immediately and continuously out, therefore I have a water seal at all times instead of a tar seal. I have followed that plan for many years, but before its introduction my stand-pipes were very bothersome. I use the same kind of coal, but am running at considerably higher heats now than I did before, or when the stand-pipes would choke up. As I advanced in gas making I found that high heats gave me better results, and so I kept them up. My idea was that the stiffer the seal the greater would be the back pressure.

The President—I think there are some present who work without any seal at all.

Mr. Light—About two years ago I adopted the adjustable seal—before that change we were much bothered with choked stand-pipes—and from the time of its adoption the trouble from that source was very slight. Now I do not average one choked stand-pipe a week. I account for it because of this movable seal.

Mr. Lindsley—At Cleveland we have 48 retorts operated with an adjustable seal. One-half of these have been running for 18 months, the remaining ones for perhaps seven or eight months, and, on account of the slight number of stoppages experienced, I might say that, practically, we are free from them. I do not recall more than two such happenings within the last six months. The gentleman at my right suggests that a possible reason therefor is the perfect fluidity of the water seal, that being a decided advantage over a seal in thick, tarry fluid. Perhaps the absence of a seal would carry this same idea far enough to prevent the formation of a carbonaceous or tarry deposit within the ascension-pipe. Possibly the pulsation of the seal, causing a continual hammering, so to speak, at some point in the pipe has something to do with the deposit. I offer that only as a suggestion. However, the fact remains since we have been working in this new house we have had almost no trouble from stoppages, whereas in our former the chokes were sources of constant vexation.

Mr. Hamlin—At Wilmington we have been very fortunate in regard

to stopped stand-pipes. I am not sure whether such relief is traceable to the plan we follow for their prevention, rather than to the fact that we do not carry our heats to the degree followed by others. The rule we invariably follow after drawing each charge is to run a tool, having a projecting piece about an inch in length on its end, around the stand-pipe. Perhaps that is the reason why we are not troubled. At any rate, the plan is strictly carried out.

The President—Our Secretary has had some experience in this matter, and since he is so busy just now I will state it. He has no seal at all, yet I know of one section of stand, bridge and dip-pipe that was completely choked up; not only so, but the pitch in the main on half a dozen occasions, in as many months, was so great in quantity and strong in quality that three days were taken up in dislodging it. To take down dip and bridge-pipes at the Columbus works is not an uncommon thing; while a choked stand-pipe is as common a thing as hair on a dog's back. Some of the pipes are seven inches, while others are eight inches in diameter, and although the latter may not choke as quickly as the former, the stoppages will develop themselves in both in short order if you get your heats above a certain degree. That is our experience, stated as briefly as I could put it.

Mr. Gwynne—Working with low heats has been spoken of as a remedy for stopped stand-pipes. We started our new plant at Fostoria, Ohio, in November, 1884, and in less than three weeks the stand-pipes in one stack were stopped up almost solidly. During the time noted the heats were so low (the new material would not heat up) that it took us from 4½ to 5 hours to burn off 250-lb. charges. The stack alongside the bothersome one—retorts, pipe connections, and seal in main (one inch) being similar in both stacks—ran straight along for two years with very little stoppage, under the same conditions and with the same coal. The heats to second bench started out very much better than those under the first bench; and thus I found from my experience that high heats are not to blame altogether for stopped stand-pipes. In fact I might go further and say that low heats will cause them to appear more quickly than high ones. Certainly, our hottest bench gave us the least trouble. We have had some bother from tarry formations close to the mouthpiece of the retort, but none at the height of, say, three or four inches in the pipe. The trouble in the defective bench is not near so great now as it was formerly, for the heats in it are improving. Burning out seems to increase the frequency of chokes. Perhaps that operation does not completely remove the original incrustation. I think if the front walls of the benches are made heavy enough, and the pipes kept at a comparatively cool and equable temperature, we will have about solved the trouble.

Mr. Huntington—Appreciating the fact that brevity is the soul of wit, I wish to move a vote of thanks to Mr. Kinsman for that concise statement of his experience with stopped stand-pipes. Adopted. A recess, to terminate at 7:30 P.M., was ordered.

FIRST DAY—EVENING SESSION.

The President—We have two papers on a kindred subject; we will hear them successively read in order to discuss them together. Mr. C. M. Converse, of Delaware, read the following on—

UNIFORM VS. SPECIAL RATES FOR GAS.

In assigning a subject I suppose it is usually intended that the arguer should take the affirmative; but I have assumed the liberty of taking the negative side of this question, and shall enter a plea for "Special Rates."

In contending for special prices it might be proper to ask what is meant by a special price. I mean a lower price, if possible, to large consumers; and also, *more especially* for day consumption used in gas stoves, gas engines and for manufacturing purposes.

There are several gas companies in the State of Ohio that have been enabled to make their uniform rate so low that it is virtually a special one. To such these remarks do not apply. And it is a further fact that *most* of the companies made the uniform rate *generally* low. But still there are certain large consumers who say they cannot afford to use gas as liberally as they desire at the uniform price. Being *wholesale* consumers, they ask for a *wholesale price*.

Increased consumption is one of the principal channels through which we hope to be able to make general reductions in the price of gas. That is the the goal which all gas companies are earnestly striving to reach; and in view of the sharp competition with which we now have to contend, it is necessary to strain every nerve, to watch every corner, and to keep every consumer, if possible, in order to attain the desired end.

Shall we try to secure a part of that increase by making concessions to these large consumers? Can we afford to lose them? or cause them to curtail their use of gas? But, would we lose them? Have we any competition to contend with? I would like to see the "Gas Man," of this

our day and generation, who thinks he possesses a monopoly of the artificial lighting business!

Is there any reason why we should not conduct our business in the same manner in which any other line of business is conducted? Would there be any injustice done to the small consumers in making special prices to the large consumers? I think not. On the contrary, they would be directly benefitted, in the end, by our being enabled to make general reductions, owing to our increased consumption.

The question might be asked, "Would the consumption be materially increased by making these special, or lower, prices? Our experience is that, in some of these special cases, the consumption has not only been increased, but the bills are as large, in dollars and cents, as they were before the reduction.

But my particular hobby is based on gas stoves and day consumption. We have had considerable experience with gas stoves, in fact I believe we are among the pioneers in that line; and we know how very materially we have increased our summer consumption through the use of these stoves. We could get them into more general use if the cost of the fuel were less, and greatly increase our summer output by so doing. I intend urging our Directors to make a special low price for gas consumed in these stoves during the summer months. The objection might be raised that if we lowered the price for the summer months, it would be difficult to resume our regular prices for the winter ones. I do not apprehend any difficulty in that respect. I think our customers could readily be made to understand that, as our running expenses are nearly the same (excepting, of course, for material) when making only a little gas, in the summer time, as when running up to our full capacity in the winter time, we could afford to ignore some of the figures going to make up the cost of production, in fixing a price for these summer months.

The regular railroad fare from Delaware to Dayton is \$2.20; yet the Railroad Company every year have large excursions to the Soldiers' Home, charging \$1 for the round trip, or 50 cents each way. I don't think any reasonable person would say that because this excursion rate is 50 cents the regular fare should be the same; and I have never heard that the Railroad Company had any difficulty in resuming their regular fare.

Are not our relations to the public somewhat similar to theirs? Would it not be practicable, as well as profitable, for us to give these good housewives a special, low-priced excursion, through these sweltering hot months, *via* the safe, cool and delightful "Gas Stove Route."

Mr. W. W. Prichard, of Ironton, then followed with his paper, entitled—

IS IT GOOD POLICY FOR GAS COMPANIES TO SELL GAS FOR STOVES, ENGINES, ETC., AT A REDUCED PRICE?

Our experience with gas stoves, engines, etc., has been limited to the past year. Probably most of you have read the article in the AMERICAN GAS LIGHT JOURNAL, issue of Jan. 17th, headed, "Something from Ironton, Ohio," making it hardly necessary for me to go over the same ground. Bringing the comparisons of the monthly consumption by each consumer entitled to the reduction for the reduced price for stoves, etc., up to Jan. 1st, adding the months together, and dividing by number of consumers, I find the result is equivalent to the following: 35 consumers, in 2½ months, increased their consumption 122,400 feet; or a gain of about 1,398 feet each per month. Our stoves are mostly small ones, only three as large as No. 7 A, "Economy," being in use.

As a general thing gas consumers are afraid of gas stoves during the first month or so, or until they find their gas bills did not increase as greatly as they expected. After that they use them more freely. It is a fact that some of the bills presented to our consumers after the first month in which they used gas stoves were actually smaller than those of the previous month, or when no stoves were employed.

One object in offering a reduced price in the attempt to increase our summer and day consumption was to utilize the idle time of both men and retorts, and to equalize the winter and summer consumption, so as not to be obliged to cool down one or two benches every spring, at a loss. Hitherto in summer we often had to keep up the heat of empty retorts during the day. By utilizing such idle time the extra cost to us is but little more than the coal used; consequently there is more profit per thousand, even at the reduced price, than on the regular night consumption. By allowing the consumer the reduced price on all gas passing through the one meter you get about the average profit, and sell more gas.

A reduced price is not only an incentive to a consumer to first try a stove, but afterwards causes him to use gas more freely for other purposes than he did at the regular price. Thus you secure an increase in quantity sold, and a decrease per thousand in ordinary expenses.

The tendency of the times is for cheaper gas. I believe, with the gas

stove as a medium, that we can increase the consumption and decrease the cost per thousand sufficiently to put us in position where we can sell gas at a price that will be *popular*.

Newbigging says: "One of the best, perhaps the very best method of reducing the proportion which capital expenditure in gas works bears to revenue, is to cultivate a day consumption of gas, by affording facilities for and encouraging, in every legitimate way, the use of gas for cooking, heating and motive power. This policy, if pursued to a successful issue, is virtually to reduce the percentage of capital in the proportion of such consumption, because the plant is brought to bear in earning profit during the daylight as well as in the lighting hours."

Discussion.

The President—Most of you have had experience with gas stoves and gas engines; and probably all of you have had some experience with special rates. Mr. Welch, of Athens, has been keeping very quite today. We would be glad to hear from him.

Mr. Welch—I hardly think I could give any information that would be of use. Although our works at Athens are very small, we nevertheless endeavor in every way to increase the consumption. We have but few stoves in use—perhaps twenty; but we succeed in placing some new ones each year. We adopted the plan of reducing the selling rate per thousand cubic feet to those who use stoves, not only for gas used in stoves but also for that employed by such users for illuminating purposes. We found it to be good policy to do this, and we expect to continue it. It is the only reduction that we make.

The President—What concessions do you make?

Mr. Welch—Our regular rate is \$2.50. We make a reduction to \$2 for gas used in stoves.

The President—Do you make the price \$2 for all the gas used where the customer employs a gas stove?

Mr. Welch—Yes, sir.

Mr. Bates—I would like to ask either Mr. Prichard or Mr. Converse what plan they pursue in selling gas cheaper for gas stoves. Whether they set a separate meter for measuring the supply to gas stoves?

Mr. Prichard—We allow them a reduction for all gas that passes through one meter.

Mr. Bates—During the whole year, or for the summer months only?

Mr. Prichard—From May first to November first.

Mr. Bates—During the past four years we have had at Tiffin quite an increase in the quantity of gas used in stoves; and, as said, our policy was to establish a special rate during the months mentioned. The gross or ordinary price is \$2 per thousand. If a person used 1,000 feet the price was \$2; 2,000 feet, \$1.75; 3,000 feet and upward, \$1.50. On that basis there was quite an increase of consumption.

Mr. Gemuender—In December, 1875, Judge Baxter, of the Circuit Court, and also the Supreme Court of Ohio, rendered decisions expressing an emphatic opinion that *quasi*-public corporations could not make any discriminations—in some of the Eastern States they have decided that gas companies were not *quasi*-public corporations; but I should judge, from General Hickenlooper's remarks, and also from the decision of Justice Harlan, that we were *quasi*-public corporations. If such is the fact, no matter whether we consider it the best policy for us as companies to pursue, then we have no right to make discriminative rates.

Mr. Huntington—In our early Columbus experience, or when we were selling gas at \$1.75, we made some concessions to large consumers; for instance, we furnished gas to hotels at \$1.65. However, when we reduced the price to \$1.25, several years ago, we considered that a sufficient concession to all consumers, and the rate was made uniform to all. My own observation at the time was that the difference in price made a great deal of trouble. If one large consumer had a concession, some other man, who burned nearly as much, wanted a similar concession also, and it was very difficult to establish a line which would give satisfaction. A uniform price, although it does not give perfect satisfaction to all parties perhaps, makes less trouble, in our experience, than the varying schedule did. We now have a good many gas stoves in use in our city. I cannot state the exact number; but I think it is about 1,500. For about seven years every pound of food consumed in my own house has been cooked on a gas stove. Neither myself, my wife, nor my cook would go back to a coal cooking stove so long as we can get a gas stove. We all like it. It is clean, it is always ready, there is no trouble in its manipulation; and a servant can manage it as well as any coal stove. I believe there is no saving to the consumer, in dollars and cents, with ordinary soft coal at \$1.85; but it is a much handier and pleasanter implement in the house than a coal stove. I strongly recommend the use of gas stoves to those who can employ them. I believe the gas cooking stove to be a good domestic institution for both summer and winter use.

Mr. Converse—I would like to ask Mr. Huntington if he knows how many cubic feet of gas per month he uses in that stove.

Mr. Huntington—I cannot give the figures; but possibly Mr. Gemuender can.

Mr. Gemuender—I cannot tell, for I do not know what quantity is used by the stove and what for light.

The President—I would call your attention to a decision recently made by Judge Demis, of Baltimore, Md., who affirms that the Consolidated Company of Baltimore might legally charge \$1 per thousand in one portion of that city while the selling rate in other sections was but 50 cents. He bases his judgment on the fact that if \$1 is not an excessive price no injustice is done to those paying such rate although others may be obtaining the same service at a much lower charge.

Mr. Gemuender—I concede you have a right to discriminate, provided you do not charge one man more than another for the same service—that is to say, 15 cents off the price for one customer, and 8 or 10 cents for another. The latter is what I understand by discrimination. It may be all right to charge 50 cents in one part of the town, and \$1 in another.

Mr. Padan—We introduced a few gas stoves in Portsmouth at a reduced rate—\$1.50; but I have always thought such practice leads to trouble. I do not think the principle is equitable. In some places the use of gas for stoves is made a plea for the reduction. For instance, Mr. Converse charges a consumer who uses a stove at the rate of \$1.50 per thousand. The stove takes up, say, 1,000 feet per month, and if the same party uses another thousand feet for light, his total expense for gas is \$3 per month; but the occupant of a store next to the premises of the stove user burns 5,000 cubic feet per month for illuminating purposes, and has to pay \$10—the case at Portsmouth is similar. Naturally the storekeeper asks, "Why the discrimination?" We answer the complaint by saying that the man to whom the concession is granted uses a stove. I think the practice will finally bring vexation. I do not think it is a good plea, although we are practicing it, and I do not know how it will terminate.

Mr. Tayler—Some years ago (we then charged \$2.50) we made an effort at Warren to induce the use of gas stoves by agreeing to supply gas to them for \$2 per thousand. In attempting to formulate a plan of how best to do it I was somewhat puzzled. I did not want to put in an extra meter, and did not want to furnish the consumers who took gas stoves with gas for illuminating purposes at the reduced figure. I was afraid that a merchant who used as much or more gas in his store might complain; or that, in order to get his gas at \$2, he might buy a small gas stove, place it in his store, and then claim to be entitled to \$2 gas. I finally concluded to estimate with the consumers as to the proportion of gas used in stoves, and that used for light; but if we could not agree on the estimate, I would put in a separate meter. We ran along very well on that plan, and increased our consumption by placing quite a number of stoves. From that time on I have worked hard to bring the price of gas down to stove rates for all purposes, and have succeeded in lessening the gap between them. I have made up my mind that our discrimination is a wrong policy, because I fail to see why it does not favor a few at the expense of others. In reality it seems to favor those who are not large consumers. Very often those who had stoves expressed the opinion that nearly all the gas used in the month had been taken up by the stoves, but my idea was quite the contrary—it had been used mostly for lighting. Lately we have been charging \$2 per thousand for gas to stoves, and a similar rate to those who use 5,000 cubic feet or over per month for any and all purposes, \$2.50 being charged to ordinary lighting users; but I hope, within 30 days, to make the bills out at \$1.80 net to everybody. (Applause.) And, by-the-way, the city during the last six years has paid the same rate for gas as other consumers. Even in the case of gas supplied to the public authorities, I am of opinion that it would be the best policy to oblige them to pay the same rate as the private citizens. I admit the cities grant us all the rights and privileges we enjoy, and that their claim for cheaper gas is paramount to that of any other consumer; nevertheless, for the benefit of consumers of gas as a whole, it is to their interest, as taxpayers and as gas consumers, to have but one price. I think if we can adhere to that rule it will hasten the day of low-priced gas.

The President—I am inclined to believe that Delaware county is not "solid" in the opinion that the "two-prices rule" is a good one, and we would like to hear from Judge Jones in the matter.

Judge Jones—I am against discrimination, not only in regard to gas rates but in all other instances as well—by railroads, banks, etc. I am inclined to think that no other phase in the present aspect of our affairs in this country looks so dangerous and so ominous to our continued prosperity as a people than this very matter of discriminations, especially so in the matter of discriminations to large operators and large consumers. One man, for example, has a couple of carloads of steers that he wants to

ship to New York; but another man who ships larger lots from the same point to reach a like destination obtains such a rebate (it amounts to a profit) that the smaller operator cannot compete with his more fortunate competitor. It goes through all the business of the farmer, likewise through all mechanical businesses, and to so great an extent that the small operators throughout the country are being worn out and driven from the field by the larger ones. You can scarcely find now one of the small wagon building shops that formerly abounded in this country; the big shops have destroyed the smaller fry. This centralization of interests destroys that distribution of products and the location of producers so essential to the independence and prosperity of the country. But to come to our own business. Suppose we make a concession to our large consumers; who really gets the benefit of that act? The saloon and billiard hall keepers, railroad offices, etc., the very parties who can and ought to pay liberally. The man whose gas bill for the month is only \$1.50 has much harder work to pay it than is the case with the party whose bill is \$70 or \$80 per month; and further, as a rule, the latter may add the price of his gas bill to the goods which he sells, and thus recoup himself. I claim that the question of right and wrong precludes such discriminations; and I ask you to distinguish between right and wrong in the gas business. You may remember that not long ago a question propounded at a meeting of one of the gas associations asked whether we ought to be governed by what was right and just, as between man and man. Now, I claim it is wrong to say to the saloon keeper, or to the hotel keeper, or to any other man who uses a large amount of gas, that he shall have his supply for \$1 per thousand; and in the next breath say to the working man that he must pay \$2 per thousand for a like commodity. There is neither right nor justice in such a proceeding. And again, I do not think you can follow out the plan legally. In fact it is out of the question to do it legally. When the people thoroughly awake to the true aspect and significance of these things I fail to know of any argument that can be used by them against a gas company that will tell with greater force against our business. Look at the reputation enjoyed by men of the railroad-swallowing stamp—Jay Gould, for instance. How does he stand in the eyes of the public? Students of political economy and shrewd observers of the drift of social conditions, assert that these practices which tend to centralize business in the hands of a few, comparatively speaking, are pregnant with greater danger to the continued healthy existence of our institutions than that coming from the presence of the nihilists or any other sort of imported ruffians in our midst. The injustice of the practice would appeal to and stir up the passions of our own law-abiding and order-loving citizens. These would be justly indignant over a plan that worked for their oppression. If we make discriminations in gas rates the people learn to expect them in other directions. A party in the town of Delaware (he has branches in other towns) gets his gas at a reduced rate because his monthly gas accounts are something like \$100 each; probably that man, on the strength of the Delaware treatment, insists upon the same concession in other localities. It is building that fellow up, but it is keeping his smaller competitors down. He has an advantage over them. You may remember that we at Delaware led off in the movement for low gas prices. I think at the time we reduced to \$2.50 no other company in the State of Ohio sold at as low a rate. We previously had made a concession to one of our hotel keepers (when the rate was \$3 he paid only \$2.50), and when we reduced the price to all to \$2.50 he said, "Now you should let me have gas for \$2." We considered the matter well, and concluded finally to make an even \$2 rate to everybody; but then the landlord said, "You have played smash. There is no sense at all in this move. That price is altogether too low. You should charge me \$2, and charge all other people \$2.50." He did not burn 100 feet additional per month at \$2 than he did at \$2.50. I really think if we had kept it up on the others he would have burned more, for he would have been delighted at the idea of being more important than his neighbors. We cannot, however, afford to tickle the vanity of such fellows. Our gas business must be so conducted that we can invite and be willing to have the light of day turned in upon it—upon our books, or upon just what we are doing; and it will not do for a gas company to transact its business in any other style. I do not think any Ohioan whose capital is invested in this business would be opposed to that. I think, as a general thing, the gas business is conducted on the highest principles of honor and business integrity. Our Legislature has passed an act undertaking to determine what we shall charge, and that act has been determined to be legal. They may enact that we shall charge not to exceed so much; and they may also enact that we shall not discriminate—there is no question about it. In point of common law Mr. Gemuender was undoubtedly right in saying that it would be illegal to discriminate. In the Granger suits decided by the Supreme Court of the United States, it was decided that the Legis-

lature might determine how much a railroad should charge; and we now have an Ohio statute in reference to the charges of gas companies. In view of all this it would seem if we were to indulge in this policy of discriminating to such an extent that people would get to understand that we were discriminating, they would appeal to the courts, or to the Legislature for redress. I do not know what sort of lawyer the man is who contended that gas corporations were not *quasi*-public corporations. They have always been so treated and so regarded in Ohio; as matter of fact, we are dependent upon the voters of the municipalities in which we live in reference to the prices we shall charge, and as to how our business shall be regulated. Suppose it should become known that, say in small towns like ours, half a dozen saloon and billiard hall keepers, railroad offices, etc., paid but \$1.50 for gas while the masses of the people were compelled to pay \$2. What do you think would be the consequence at the next election? What would they say (I mean those who reason fairly without any reference to the demagogues) about that policy? They will say, I think, "You had the privilege of digging up our streets and laying your pipes; we gave you a franchise, with its privileges, and now you seek to discriminate between our citizens." I say, therefore, that discrimination in prices charged for gas, used for the *same purpose*, is unjust. Now, in reference to gas sold for mechanical and domestic purposes. Even if a general lower rate is charged therefor than that used in lighting, there is no discrimination. All are treated alike. I am inclined to think favorably of that policy, and we have been considering whether we should not institute it at Delaware. For instance, a local printing office in our town uses a gas engine—one other engine is employed by another party, and quite a number of cooking stoves have been put in, as Mr. Converse stated in his paper. I further believe that when gas rates reach the lowest possible point only one general rate for all purposes shall prevail. Take Columbus, for instance. I fail to see how any concessions could be granted there. I do not see how they managed to get the \$1.25 rate at Columbus; but I suppose it must be owing to the extraordinary talent shown in the management of the Columbus Company's affairs. I suppose we can make a somewhat lower rate at Delaware than the \$2 one, and I think it very likely that we shall do so in the near future. I agree with Mr. Converse in his statement that if anybody more than another is to be encouraged it is the house-wife who does her own cooking; and I would help her by popularizing the use of gas for domestic purposes.

Mr. Fette—When I was invited to say something this morning, I replied I had not come to speak but to listen. I have listened to what has been said on this subject with a great deal of pleasure; and I wish to affirm that I am in favor of these discriminations, although not sure as to their legality. As Judge Jones put it, I suppose discrimination cannot be legal. I cannot see, though, why people who buy goods at wholesale are not entitled to lower prices than those who buy goods at retail. This rule is adopted in every other kind of business. We all expect to pay more at retail than at wholesale. That is one argument in favor of discriminating to the advantage of the large consumer. Another argument is that it costs less to supply that large consumer than it does to supply the same amount of gas to a large number. In the case of one company that I have in mind a single consumer burns $1\frac{1}{4}$ millions cubic feet of gas in the year. He has but two meters. If that same amount of gas was burned by the average consumer of the same place about 250 meters would be required in the measurement. Each of those meters would represent an investment of \$7 or \$8, one or two additional men to take statements, 250 separate bills, with the extra trouble of their collection, etc., whereas the single customer requires but two meters, no trouble to read the statements, and so on in contrast with the 250. The same gas company to which I allude did have as a consumer another manufacturing company right alongside of the gas works—just as that hall is alongside of this room. We could run a pipe into that mill and supply it with gas much cheaper than in the case of the supply to the party who burns the $1\frac{1}{4}$ millions cubic feet per year, because we would save 15 or 20 per cent. of leakage—the building or establishment of the latter is three miles distant from the gas works. Prior to my connection with the gas company, its owners had the misfortune to lose as a consumer the mill alongside of the gas works, because the price was maintained at the same rate as that charged to other consumers. That mill used one-quarter of the whole amount of gas sold by the company at the time. I can name no price to that manufacturer which will induce him to take our gas again, for he put up his own works. I think these two illustrations are pretty strong arguments in favor of discriminations.

Mr. Gemuender—Mr. Fette remarked that wholesale dealers sell at lower rates than retail dealers; that they would sell at a lower rate to a wholesale customer than they would to a retail one. Does the wholesale dealer make a larger margin of profit than the retailer?

Mr. Fette—That I cannot say.

Mr. Gemuender—I do not think so. If it were so no man would start a retail grocery. I think that the interest on the capital invested is exactly the same in both cases.

Judge Jones—If I may say another word, in answer to the the remark of Mr. Fette about the large consumers. I think the important question for us to consider is whether those few wholesale or large consumers are of as much importance after all to our companies as the mass of small consumers. I claim they are not; they do not begin to be; and we cannot afford to sacrifice the interests of the mass to the interest of the few, merely because it would seem to be an advantage in our favor when we consider the cost of supplying them as compared with the cost of supplying the large consumers. We should never forget that we are dependent upon the mass of the people, who are each contributing a little for our support, and that we cannot afford to do a thing which seems to be unjust to them simply because of the respective money aggregate of their dealings with us.

Mr. Prichard—I think it is a question as to who is making the discrimination. If we can, through utilizing idle labor and plant, cheapen our cost of manufacture in the sum of 40 cents per thousand, simply through working in the daytime, I think we ought to grant those who use gas in the daytime a concession for the good they have done us.

Mr. Ross—I have a case in mind, that happened in Kenton, which bears on this question. We had discriminated heretofore by charging \$2 for gas used in domestic and mechanical purposes, while lighting consumers who used less than 2,000 cubic feet per month were charged \$2.50. On January 1st we made the price \$2 to all, and find that our people are very much better satisfied. There is less complaint. I had one customer—a barber—who used 2,000 feet in one month, and paid \$4 therefor; but his near neighbor—another barber—who used only 1,900 feet, paid me \$4.75.

Mr. Converse—I somehow had the impression that we ran our gas works to make money, and I fail to see where we are doing any injustice by selling this gas in the summer time at a lower rate. As Mr. Prichard said we can make this gas for day consumption at a really decreased cost. In Delaware most of the gas stoves are used by people in moderate circumstances, or in situations where the housewives do their own kitchen work, hence it seems to me, if we wish to benefit people in moderate circumstances, we can do so directly in that way. They use very little gas for illuminating purposes. In the winter time their gas bills are from nothing to 20 cents each month. They cannot use gas generally at our rate of \$2 per thousand. A gas stove will take up from 2,500 to 3,000 feet per month, and I question very much whether 3,000 feet is not a little short of the mark. Of course, if it is illegal to discriminate after our fashion at Delaware, that ends it; but if the contrary is the case, a profitable field is open for us.

Mr. Ross—We find that our stove consumers have been benefited by equal prices. They are getting fuel for less than they got it before from any other source. We have 28 or 30 stove customers who use gas for cooking in the summer, and for heating purposes in winter, and the average charge is about \$1.60 per month. In not a single case has the consumption on stove account reached 2,000 cubic feet per month.

Mr. Converse—Your consumers cannot use a gas stove when washing or ironing; and it would seem that they do but mighty little cooking. At \$2 per thousand your average would equal 800 feet. We have followed the gas stove business pretty closely—in 1884 about 244 stoves were in use—have personally shown our consumers how to use the stoves, and called in occasionally to inspect them, but I fail to remember an instance where a person was able to do much cooking—not to mention anything about washing and ironing—on a consumption of gas considerably above 800 cubic feet per month.

Mr. Bates—My experience shows that where the ordinary consumer, for lighting purposes in the summer, burns 800 feet, his bill will increase to 3,000 or 4,000 feet when he obtains special rates for cooking purposes. This shows that the average users of gas stoves do thereon their cooking, and more or less ironing, perhaps not all of the latter, but the uses to which they put them will increase the consumption 2,500 or 3,000 feet. I think it pays to give low rates. I think we have just as much right to do so as any wholesale dealer. Any man who will charge 25 cents per pound for coffee at retail will let you have it at 23 cents if you buy by the hundred pounds. I think we have the right to sell our gas in the same way.

Mr. Ross—Some of our best citizens are cooking in the summer time with gas fuel. I cannot say about washing and ironing. I think that our people who use gas stoves for cooking usually have their washing and ironing done away from home. So far as cooking is concerned, I can only say to you what they tell me. I ask them if they do all their cook

ing with gas, and the usual reply is, "Yes." Some few of them say they burn it in the grate at times. I find that their gas bills are not as much in summer time, for all purposes, as they have been in winter time for light alone. I have averaged the bills of a number of families who use cooking stoves in the summer, and the figures show \$1.60.

Mr. Padan—My objection to the plan suggested in the papers is not that I am opposed to discriminating in favor of large users, but because I object to discriminating in favor of small dealers, as this gas stove business seems to do. We have had people who purchased small gas stoves, using them occasionally for heating, never cooking anything with them, just to get the lower rate. I do not object to discriminating in favor of large dealers. What is the use of objecting to the plan? We *will* do it; and that is the end of it.

Mr. Christian—I think a good way to get over this difficulty is to do as I have done in two cases. When a party asked me what gas would cost for cooking I asked how large a stove he desired to use—a two, three, or four burner. Having answered as to the size, I tell him what it would cost to supply gas to it. I do not put in a separate meter, but charge him in accordance with the specified agreement. In that way I think we get a good figure for our gas, and are not discriminating.

Mr. Padan—Do many of them do washing and ironing with the gas?

Mr. Christian—They all do washing and ironing with it when you give them the gas in that way.

Mr. Converse—I think it is pretty evident Mr. Ross has not made a success in the stove business if his people get along with so small a quantity of gas, and if such use is confined to the wealthier class of people. Our experience is right the other way. I know that every gas manager, particularly those in small works like ours, takes pride in seeing how much he can increase his output each year; and I think day manufacture and day send-out is the point we all should strive to develop.

Mr. Thompson—I would like to ask Messrs. Converse and Bates about the size of these families who use three or four thousand feet of gas per month to cook with. I think they must have numerous and healthy appetites for breakfast, dinner and supper, with zest for sundry hot lunches between. Three thousand feet of gas for cooking purposes, in an ordinary family, in the towns in which our friends are located, looks like an enormous quantity. I have been using a gas stove for four or five years, and although my family is small, our entire work is done on it. Averaging it through the summer and winter, we use 1,000 cubic feet per month.

Mr. Converse—Do you bake on your stove?

Mr. Thompson—Yes.

Mr. Converse—Washing and ironing also?

Mr. Thompson—No; everything except that.

Mr. Gwynne—In Fostoria we have about 45 stoves out, and the average monthly consumption of each is from 1,500 to 2,000 cubic feet. The price charged for gas for cooking is \$1.50 per thousand, which is a special rate lasting from April 1st to Oct. 1st. Last year these 45 stoves brought us in about \$1,000, which is almost a clear gain, less the actual cost of the coal and purifying material used, for the retorts would otherwise have stood idle during the daytime. As to the sliding scale charged for illuminating gas our gross price is \$2.50 per thousand, with discounts ranging from 5 to 15 per cent., in accordance with the quantities used each month. We find those rates work very nicely. We have had very little "kicking" over them. I do not think others will have any more trouble than we have had if they will only take pains to explain the situation to their customers.

Mr. Bates—According to my experience storekeepers will pay \$2 per thousand for gas used at their stores, and \$1.50 for gas consumed at their houses for cooking and lighting, and make no comment. They are at least receiving the benefit of the plan in their household arrangements, and are perfectly satisfied to pay the two rates. I think one reason why the consumption of gas in a stove increases after the first month or so of its use lies in the fact that the housekeepers become a trifle negligent and do not shut the burners off at the moment they ought. People have said to me they put gas stoves into their stores for the purpose of getting the cheaper rate. I told them we were selling gas to make money; that if we sold at a special rate for cooking purposes it was because we could run the gas works in the daytime and utilize the works; that if we could sell it to them cheaper for the purpose it was because we were able to make it cheaper. When they suggested putting stoves in their stores so as to get the lower rate I told them that it would not do, for the question was not whether a man had a stove but whether he used it. At Tiffin the result has been very favorable. For the first two months from the time the people used stoves we had a good deal of dispute. We ended the grumbling by saying that we were running the thing to make money, and fixed our rates, and proposed to do thus and so.

On motion of Mr. Butterworth, a vote of thanks was tendered to Messrs. Converse and Prichard.

(To be continued.)

The Proposed Massachusetts Law to Regulate the Supply of Electric Light by Gas Companies.

The following is the text of the Hartwell bill to allow Massachusetts gas companies to engage in the business of electric light supply:

SECTION 1. The Board of Gas Commissioners, upon application in writing by any company organized or chartered under the laws of the Commonwealth for the purpose of making and selling gas for illuminating purposes, may, after such notice and hearing as said Board shall deem proper, authorize said company to engage in the business of generating and furnishing electricity for light and power in all or such part of the territory in which it is authorized to supply gas as said Board may designate; provided, however, that said company shall not engage in said business so authorized unless by a vote of two-thirds of the stockholders, representing not less than two-thirds of the stock, at a meeting duly called for that purpose. Said company so authorized shall file in the office of the Secretary of the Commonwealth a certificate as provided in section 51 of chapter 106 of the Public Statutes.

SEC. 2. Said Board shall at the time of granting said authority prescribe the time, not exceeding eighteen months, within which said company shall erect and equip such a plant for generating electricity for light and power as may be required in the specified territory, and designate the minimum capacity of such plant; and if said company shall neglect to erect and complete said plant within the time prescribed, said authority shall thereupon become void, and no such authority shall be again granted to said company within two years thereafter; provided, however, that said Board may for cause shown extend the time first prescribed for erecting and equipping said plant not more than six months from the expiration of the time first prescribed.

SEC. 3. At the expiration of the time and extension thereof, if any, given under the preceding section said Board shall, after such examination as they shall deem proper, make, in a book kept for that purpose, a record as to whether their orders with reference to the erection and completion of said plant have been complied with. Said record shall be conclusive evidence of the truth of the matters stated therein, except in cases of the purchase or lease of the property, licenses, rights and franchises of some electric light company, as authorized under section 9 of this act.

SEC. 4. Said company shall not erect or maintain any poles for the support of wires, nor erect or maintain any wires in, through, or over any streets or highways, nor dig up any streets or highways for the purpose of laying said wires underground, until it has (upon petition in writing by said company) first obtained the consent in writing of the Mayor and Aldermen of cities or Selectmen of towns in which said streets are located.

Said company having obtained such consent, may, under the direction and control of the Mayor and Aldermen or Selectmen, dig up and open the grounds in any streets and highways, so far as is necessary, for the purpose of laying lines of wires to carry into effect the authority given under this act, and for the purpose of keeping said lines in repair, and to erect and maintain lines of wire upon or above the surface of such streets and highways.

The said company shall put all streets and highways which are opened into as good repair as they were in when opened, and after failure so to do within a reasonable time shall be deemed guilty of a nuisance.

SEC. 5. When a party, injured in his person or property by a defect in a street or highway caused by the operations of said company in laying down, erecting, maintaining or repairing its lines of wires, or otherwise obstructing such streets or highways, recovers damages therefor of the city or town wherein such injury is received, such city or town shall, in addition to the damages so recovered against it, be entitled to recover all the taxable costs of the plaintiff and defendant in the same action in a suit brought against said company, if said company be liable for said damages, and if reasonable notice is given by such city or town to it, so that it may defend the original action.

SEC. 6. The Mayor and Aldermen of cities and the Selectmen of towns, respectively, may regulate, restrict and control all acts and doings of said company which may in any manner affect the health, safety, convenience or property of the inhabitants of their respective cities or towns.

SEC. 7. Gas companies, as respecting the business in which by this act they are authorized to engage, shall be subject to the control of the Board of Gas Commissioners in the same manner and to the same extent they now are or hereafter may be respecting the business of furnishing gas.

SEC. 8. Except as hereinbefore expressly provided, gas companies shall (in exercising the powers conferred by this act) have all the powers and privileges and be subject to all the duties, restrictions and liabilities set forth in all general laws which are now or hereafter may be in force

relating to companies engaged in the transmission of electricity for light or power.

Sec. 9. Said gas companies so authorized shall have the right to purchase or to lease and to use all or any of the property, licenses, rights, privileges and franchises of any electric light company engaged in the business of furnishing electric light or power in the territory in which such gas company may be authorized to furnish such light.

Sec. 10. This act shall take effect on its passage.

Otto Gas Engine and Lightfoot Refrigerator.

The Engineer, Loudon, England, calls attention to the following example of the effectiveness of the above-named combination in carrying on the special duties described. Our authority says:

To meet a want that has long been felt by butchers, poulterers, fishmongers, chocolate makers, and others for a cheap, simple, and efficient means of cooling, Messrs. Crossley Bros., Manchester, have recently brought out the

We may mention that a gas-driven refrigerator on Lightfoot's system has been in constant operation for about two years in the vaults of Messrs. J. S. Fitter & Sons, Leadenhall Market, where it has given the greatest satisfaction. There are four chambers capable of together holding some twenty tons of meat. It has been found that about six hours working per day suffices, and there is no difficulty in maintaining a temperature below freezing during the night, and from Saturday to Monday, without running the machine after ordinary hours. In winter the water, after performing its cooling duties in the refrigerator and gas engine, is used for heating the offices. During the two years this machine has been at work no repairs have been required beyond the occasional setting up of the brasses.

The principal advantages of such a combination as we have described are—economy in first cost and in space occupied, cleanliness, convenience, and saving in attendance, as no skilled labor is required. The machine is practically noiseless in action, and is readily started and stopped at a moment's notice. We need hardly add that it is of great importance that machines of this kind should run without risk of breaking down, and in this respect the Lightfoot refrigerator has proved most satisfactory.

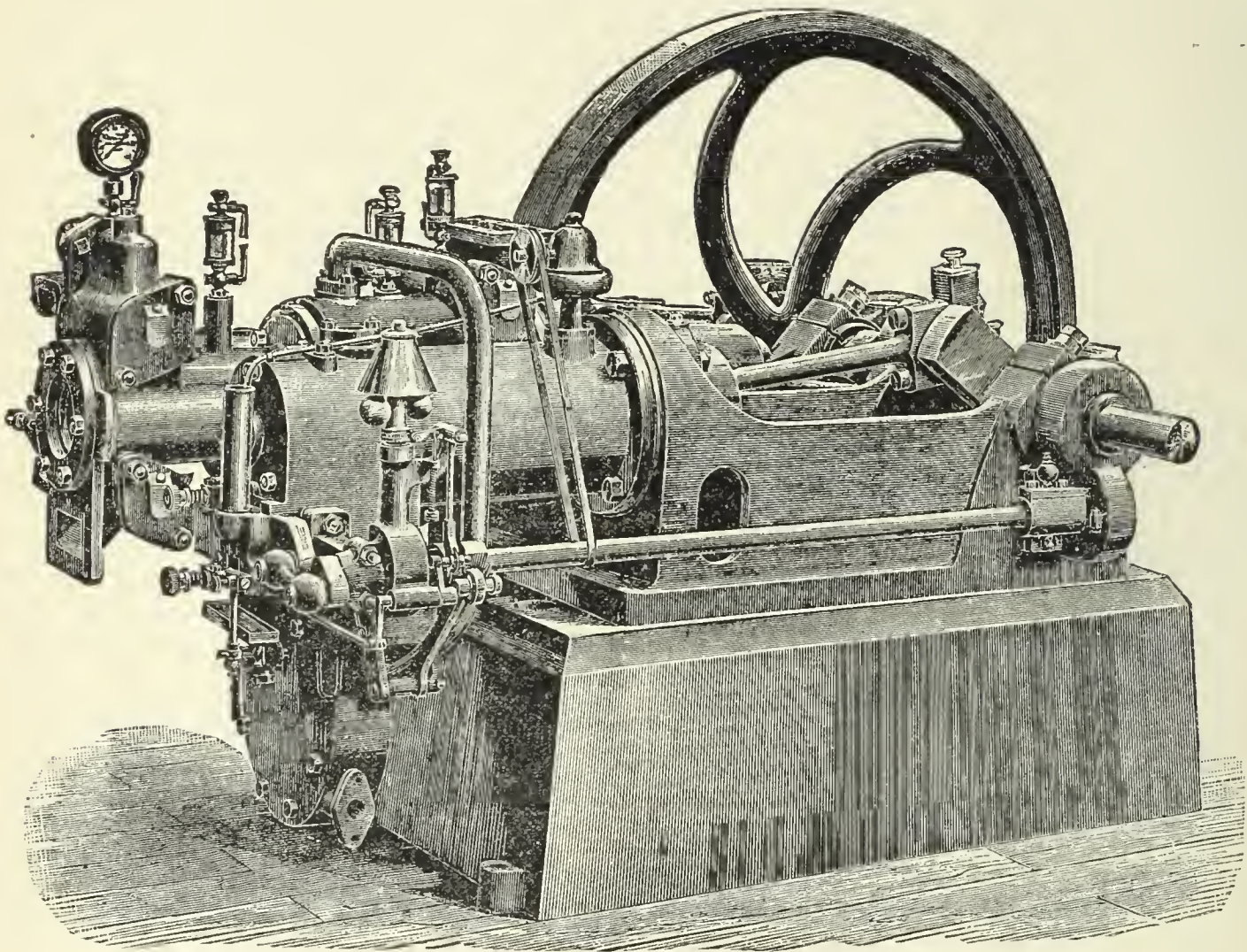

Combined Gas Engine and Refrigerator.

machine which we illustrate above. It consists of one of their latest type of Otto gas engines, combined with a Lightfoot's patent dry air refrigerator of similar construction to that which obtained the gold medal at the International Health Exhibition. The air cylinders are combined in the usual way, and are placed alongside the gas cylinder, the two sets being bolted up to a neat frame. The air cooler with drying apparatus is in the pedestal below, the arrangement being such that the water passes first through the cooler, then through the jacket of the compressor, and finally through the jacket of the gas cylinder; water vessels are therefore dispensed with. In the refrigerator, as well as in the gas engine, the simplest and most straightforward design has been followed, in order not only to reduce first cost, but to enable every part to be readily accessible and easily kept in order. The air valves are of the Corliss pattern, with positive action, allowing the apparatus to run at a high speed with economy and efficiency. It has been found after several years of experience that these valves last well and require no attention beyond lubrication—matters of great importance, when, as is frequently the case with gas-driven engines, the plant is left to itself during the greater part of the day, and is only occasionally looked after by an unskilled attendant.

The machines are made in several sizes, to deliver from 2,000 to 6,000 cubic feet of dry cold air per hour, but smaller and larger combinations can be made if required. The gas engine can be disconnected from the refrigerator, so as to be applied to other purposes when cooling power is not required.

How to Select Cast Iron Pipe.

[Mr. Geo. W. Pearsons contributed the following rules in the above regard at the last meeting of the American Water Works Association. Perhaps Brother Decker, of the Hannibal (Mo.) Gas Light Company, could be prevailed upon to give his views on Mr. Pearson's conclusions. Certainly, the Hannibal gas man is thoroughly conversant with the subject.—ED.]

Uneven Castings.—In past discussions the fact of pipe being sometimes thinner on one side than on the other has been passed over as a rare, and probably not very serious fault. My experience in laying some 130 miles of cast iron pipe, and its test by direct pressure, leads me to consider it one of the most common and serious faults we have to contend with—a large majority of the broken pipes that I have seen developed this inequality. I speak of pipe broken in the ground by pressure.

Quite frequently I have found such pipe broken, with an irregular angular fracture, always on the thin side. The fracture, instead of being radial, being diagonal to the surface and resembling a rough tear. I have never seen such a fracture made by breaking a pipe in any other manner, and think it must be due to unequal contraction in cooling, caused by the unequal thickness.

Such a pipe is dangerous whether it has passed the test or not—all such pipes which I have seen broken have been tested to 300 pounds, according to the statements of the manufacturers—and, notwithstanding they showed

no fault on careful inspection before laying, have generally given way before the pressure reached 100 in the ground.

Pipe can be tested for unequal thickness by being rolled slowly over level skids by a single operator—any pipe which shows a disposition to get away should be allowed, in fact be aided in the tendency. The best place to do this is in the pipe factory before the pipe has gone into the tar bath, and I think if the importance of this were realized by the makers it would be done.

I know as regards water test that all I have seen has been apparently done with proper care; but do we, or even the manufacturers, know that their workmen are always faithful in this if they are not well watched.

Pipe Weight.—My experience fully justifies the use of as light pipe as indicated by the discussion.

Lead Room.—How can a reasonable uniformity of lead room be maintained? I have had a gang of thirty men up all night chipping the spigot end of two specials to get them into the bowls into which they were to fit—all standard weight pipe from the same factory; and from the same factory have laid pipe in which the lead room was from five-eighths of an inch to over one inch.

Remedy.—Call for standard outside sizes of pipes, and require all manufacturers to conform to these sizes, leaving the inner diameter to be governed by the thickness of the pipe. Most of you lay pipes from different factories, and I presume, like myself, have suffered from the difference of sizes.

Yarn and Lead.—The yarn should fill to the lead score; the bead on the pipes takes, with some irregularity in alignment, perhaps one inch; yarn, one inch; lead, one and one-half inches; three and one-half inches, say three inches in small pipe, and four inches large is deep enough for the bowl.

How to Get Good Pipe.—Buy it by the lineal foot instead of by the ton; specify, if you desire the minimum thickness to be used, and the water test required; then the manufacturers will take pains to keep out overweight, and will be enabled to make skill in manufacture a paying item in their works. As it is now, the superiority of one maker over another in this particular has no market value. Buy specials by the piece.

Incandescent Lights on High Tension Circuits.

At the Philadelphia meeting (Feb., 1887), Mr. Jos. Wetzler read the following paper. Our report of same is from *The Electrician*:

The demand which the public makes for electric lighting must be satisfied, and although the arc satisfies it to a considerable extent, experience has shown that the incandescent light is in equal demand and that arc light stations are called upon to furnish it. The service is found to be equally as profitable as arc lighting; and hence the introduction, by way of necessity, of incandescent lamps on arc circuits has become quite general.

The object aimed at is to reduce the quantity of copper required for the distribution of the current to incandescent lamps. This is accomplished by increasing the electro-motive force employed on the circuit, and reducing correspondingly the total current required.

It is proposed in this paper to give a resume of the various ways in which this may be carried out, so that those interested in electric lighting may become acquainted with what has already been done and suggested. It will be necessary at the outset to state that it would be injudicious to assume that any one system is given as a perfect solution of the problem, for the conditions of service vary so much in each case that where one system would be a success, another might prove a failure. In other words, we must look at the question in a broad light and consider that all of these systems have their field of application, which depends alone on local circumstances.

Very early in the history of electric lighting Mr. Edward Weston proposed the placing of incandescent lamps in multiple series, by means of which they could be connected to a high potential dynamo. He was followed by others who adopted the plan of inserting the incandescent lamps in arc circuits. The usual method of doing this, as you all know, consists in employing a "distributor," which, generally speaking, is a device for connecting incandescent lamps in multiple series on an arc circuit, and which contains mechanism for preventing an increase of current when a lamp breaks. These devices, of which there are several forms in use, among them those of Brush, Slattery, Little-McDonald, etc., need not be more particularly described here, as they are already known to all of you. They are of undoubted value, but they cannot be said wholly to satisfy the general wish of electric light men for maintaining incandescent lamps on high-tension circuits.

The question then arose, How can the field of incandescent lighting be broadened so that the benefits of small-wire circuits can be taken advantage of, and so that the electric light can in the fullest sense take the place of gas as an illuminating agent?

This question can be answered in a variety of ways, each of which may be

correct. I will take up the discussion by presenting the most simple case, and that is, the running of incandescent lamps in plain series, similar to the disposition of arc lamps. This has been successfully accomplished in one way, in what is known as the Edison municipal system. If we examine into the condition under which this system can be operated, it appears that we have here a field which is well worth looking into, and as it has not, to my knowledge, been brought prominently forward, I propose to give a few details of what can be accomplished by it. One of the main objects for which this system was devised is the displacing of the street gas lamps. As such it evidently comprises in itself the use of very long circuits, and their economical operation is a first consideration. The dynamos employed for this service have an E. M. F. of 1,200 volts, which allows for any drop in potential that may be desirable up to 17 per cent. in the wire, while a pressure of 1,000 volts is left to be expended in the lamps. The largest type of dynamo constructed for this system can feed 12 distinct circuits, upon each of which about 65 lamps of 15 c. p. can be placed, or 800 lamps in all. Each of these circuits carries a current of only 4 amperes, so that only a very small wire is required to convey the current, a number being generally employed.

With twelve circuits at our disposal from a single dynamo, it is evident that a wide range of distribution is possible, and the small cost of conductors is a decided advantage. Then again, the system permits of placing lamps of greatly varying candle-power anywhere in the same circuit, ranging as high as 50 c. p. Thus each circuit is capable of feeding lamps aggregating 1,000 c. p., whatever be the illumination of the individual lamps employed. This gives a basis of calculation upon which definite results can be quickly predicated. The system, such as it has been outlined here, is in operation in various cities, among them Portland, Me., where 500 lamps are so connected; Lawrence, Mass., with 550, and Denver, Col., with 530. While it is principally designed for street lighting, the system is also adapted to interior lighting where the load is a constant one, as in stores which remain lighted up to a fixed hour in the evening.

A system similar to the one described has recently been put in operation by Mr. Chas. Heisler, in St. Louis, and also in Vincennes, Ind.

A recent interesting modification of the method of running incandescent lamps in series has been brought out by Mr. Alex. Bernstein in England. His method consists in utilizing the full arc current of about 10 amperes as ordinarily employed and running incandescent lamps of low resistance, which require only six volts E. M. F. Thus with an arc dynamo developing 2,000 volts, over 360 lamps could be placed in series. Several installations on this plan have recently started in England, and with reported good success.

A still more recent method of similar design is that of Prof. Elihu Thomson. This also consists in doing away with distributors and placing incandescent lamps directly in series in the same circuit with arc lamps. These lamps take the full current, and lamps of different candle-power can be inserted in the same circuit. In all these systems, provision must evidently be made, and now is, for preventing the interruption of a circuit when a lamp is extinguished.

There are still other methods of intercalating incandescents on high potential circuits. One of these is by means of induction through what are called secondary generators. As I understand that another member has prepared a paper dealing with this highly important branch I shall leave it with this mere mention and draw your attention to a second method by which induction can be utilized for running incandescent lamps directly on arc circuits. This is the method devised by Mr. Ph. Diehl, which has lately been made public. The incandescent lamps in this system are arranged in two branches, between arc lamps, and a current interrupter is so arranged that the current is alternately broken in one set of lamps and simultaneously sent through the primaries of the other lamps. Thus the main current remains continuous and unbroken, while the rapid interruptions in the incandescent branches induce the current required to bring the filaments to incandescence. Lamps of any desired candle-power can thus be easily inserted in the circuit.

This outline of the principal systems will give electric light men some idea of the various methods by which the incandescent light can be brought into service without the necessity of employing large conductors.

Thus far, I have only alluded to methods where the connection between dynamo and lamp is a direct one, but there are still other methods which come under the title of this paper, but which have hardly yet forced themselves upon the attention of those present. I refer to the use of storage batteries as an adjunct to an electric light station. You will probably all remember that when the storage battery was first brought out prominently, it was said that each house could now be provided with its quota of batteries, which, being charged from a central station during the day time, could furnish current for the lamps in the hours of darkness. During the past few years, while the storage battery has been in a state of slow evolution, this idea has almost fallen into oblivion; but I think the time has arrived when the problem should again be attacked in earnest and be brought to a practical solution. The reliability of the storage battery is now beyond

cavil, and it only remains to work out the details. Let us glance for a moment at the method employed here, and see what it involves. In the first place, your arc light dynamos, which now lie idle on an average sixteen hours out of the twenty-four, could be run practically during the whole twenty-four hours, charging the batteries in the circuit in the houses during the day time and doing their regular lighting as usual at night. Thus no additional machinery or boilers will be required. Considering the installation in each house, all that would be required would be a battery of accumulators which, for economy of current, should have an E. M. F. of about 60 volts. This would be reached by 30 storage cells, which can be placed on a shelf in the cellar. Such cells, which can now be obtained in the open market, would be capable of furnishing current for 15 lamps, and one charging of 12 hours would, with the ordinary number of hours of lighting, last for 3 days, provided all of the 15 lamps were lighted at the same time. Where the number of lamps is less, the time required for the battery to become discharged would be still further prolonged. A dynamo of 3,000 volts, E. M. F., and having a current of 20 amperes for your purposes, or two arc dynamos, giving each a 10-ampere current, coupled in parallel, would be able to furnish current for 50 houses, each absorbing 60 volts, E. M. F. The conductor required for the purpose need not be greater than a No. 4 B. & S. wire.

To make the system perfect, suitable automatic switches can be arranged in each house, which would cut out the battery when the latter is fully charged and throw it into circuit again when discharged. In this manner it is probable that considerably more than 50 houses could be supplied from a 3,000-volt circuit, as not all of the batteries would be exhausted or charging at the same time. Here, then, is one method by which, without a very greatly increased expense, the earning capacity of electric plants can be increased, and I believe the time has come when you should seriously consider the working of the field here presented.

But there is still another way in which the storage battery can be made to do good service for incandescent lighting from arc light stations. As stated before, the dynamos at the station are idle for a large fraction of the day. Now, nothing would be more simple than to charge the storage cells in series at a station during the daytime, and then couple them in quantity, so that they could be connected to incandescent circuits radiating from the central station, which would thus be virtually a secondary battery station. It is a well-established fact that incandescent lamps are not used on an average more than four hours per day, the current required in incandescent circuits during the remaining twenty hours not reaching 15 per cent. of the maximum called for during lighting hours.

Let us again take for example a station having only three 40-light dynamos of about 2,000 volts and 10 amperes each. By coupling these in parallel we would obtain a current of 2,000 volts E. M. F., and 30 amperes. This current from 6 A. M. to 4 A. M., or ten hours, could be used to charge a battery of 1,000 storage cells, delivering to each cell 30 amperes for ten hours; that is, 300 ampere hours. Now, at four o'clock these 1,000 cells which have during the charging been connected in series are changed about so as to be connected in 20 parallel rows of 50 cells each, thus giving an E. M. F. of 100 volts, suitable for incandescent lamps. Each of these twenty rows having a capacity of 300 ampere-hours the entire series of 20 are capable of delivering 6,000 ampere-hours at a potential of 100 volts. Now, if we suppose that with the resistance of the circuit each lamp requires 1 ampere it follows that 6,000 incandescent lamps could be lighted for one hour, or 1,500 for four hours, the maximum average lighting duration established by actual experience. Thus, by the mere addition of 1,000 cells to an arc light station with only three 40-light machines, we could, without the addition of any machinery whatever, by the mere adjunct of the storage battery, furnish current for 1,500 incandescent lamps, and maintain them with the utmost degree of steadiness.

What has just been stated with regard to arc light stations is equally true of incandescent light stations. Instead of having the majority of machines idle during 18 hours out of twenty-four, a few machines might be run continuously, charging storage batteries which would furnish the supply of current needed during the busy hours.

Such a station, the first of its kind in the world, I believe, is now in course of construction at Haverford, not far from this city of Philadelphia, and I am convinced that the results which will be obtained will justify courageous wisdom on the part of its projectors.

I believe I have shown that those principally interested in arc lighting have a number of paths open to them by which they can with profit add the incandescent light, or for that matter electric motors, to their business. I need only remind them that the street lighting, which most of them are engaged in at present, embraces only 5 per cent. of the total lighting done in this country, and that of the remaining 95 per cent., according to our present knowledge, only 5 per cent. more can be touched by the arc light. The remaining 90 per cent. must be done by incandescent lighting.

Big Gas Bills Paid on Account of Household Consumption.

A recent issue of Mr. Dana's latest venture in the field of newspaperdom (the *Evening Sun*) contained the following:

"What private individual pays the biggest gas bill in the city, did you say? Well, that is a funny question, but I think I can answer it," said an old clerk of the Consolidated Gas Company. "Let me see," he mused; "I think Pierre Lorillard goes ahead of anybody in that respect. Yes, he leads the list with from \$300 to \$400 a month for gas consumed in his house, and he is a very prompt payer, too—sends a check for the amount as soon as the bill is turned in, and never kicks at all."

"Never kicks?"

"No, never; which is saying a good deal. Some of the rich men who don't burn much more than a tenth of the amount Mr. Lorillard uses will haggle over the bill, and swear that the meter must be wrong by the half hour at a time. Take William Rhinelander, for example. His bill amounts to a little over \$40 a month, and he always finds fault with it. He has his little talk first, and then pays it in brand new bills. Counts 'em over three or four times, too.

"A. T. Stewart was very close about his gas. That big white marble palace of his at Thirty-fourth street and Fifth avenue couldn't have been very brilliantly lighted at night when he was alive, for his gas bill was seldom over \$20 and never went beyond \$25. Of course these figures are for the winter months, when the people are at home.

"Judge Hilton lights things up in his house at 1 Thirty-fourth street in a much more lively style than did his old partner and neighbor. His bill generally takes a \$150 check to settle it, and often it goes over that amount.

"The Vanderbilt houses on Fifth avenue and Fifty-second street range from \$200 to \$250 a month each in the winter. Sometimes the bill is bigger, but not often.

"A. B. Stockwell used to burn \$150 worth of gas in a month, but he's not doing it nowadays.

"I remember two old maids who lived for many years in a big house on Madison avenue near Thirty-fourth street. Their bill never went above \$3 or \$4 a month. They made their servants use candles in their rooms. Lots of wealthy people do that. They think a tallow dip is good enough for a servant, but they spend hundreds of dollars for their own chandeliers. Well, these two old maids rented their house to another family last year, and the same meter now measures out \$75 to \$100 worth of gas a month.

"There used to be an old Irishman named Judge who owned lots of houses and flats on the east side up town. He was a builder, and was putting up flat houses all the time. His gas bill was never over 50 cents a month. He lived in one of his own flats on East Fifty-second street, but his gas bill hardly paid for the wear and tear of the meter. He always was on hand when our man examined the meter, and could read it to the fraction of a cent, I believe.

ITEMS OF INTEREST FROM VARIOUS LOCALITIES.

ANOTHER DECISION IN FAVOR OF THE OWNERS OF THE OTTO PATENTS.—The proprietors of the Gas-motoren-fabrik Dentz, of Dentz, Germany, owners of the Otto gas engine patents for Germany, to whose operations much attention has recently been attracted, because of the large sizes of Otto engines constructed by them and furnished for power purposes to city water works and important electric lighting installations, have just obtained a decision in their favor in their suit against Moritz Hille, of Dresden, a manufacturer, and several of his clients who were users of infringing engines. The decision establishes the infringement by the defendants, orders them to discontinue the manufacture and use of the machines, also to account for damages. The Hille engine employed the now well-known Otto four-stroke cycle. The suits now pending against Korting Bros., and Buss, Sombart & Company, are also based on that application. In the latter cases a decision may soon be expected.

AN INTERESTING LEGAL DECISION.—Some time since the City Engineer of Little Falls, N. Y., entered into contract with Messrs. Sullivan & Company to make extension of the city's system of water supply conduits. During the progress of the work Sullivan's employees, through carelessness, fractured a main of the Little Falls Gas Light Company, whereby the latter lost upwards of 30,000 cubic feet of gas. Sullivan, backed by the advice of the City Engineer, refused to pay the gas company's bill for same (involving about \$81, at the rate paid by ordinary consumers), and the law was invoked. The case was tried before Justice Sherman, and a jury, who, on the evening of April 5th, returned a verdict in favor of the plaintiffs, damages being fixed in the sum of \$47.63. That adjustment was based on the probable gross cost to the Gas Company of the gas at the point where the escape occurred. The proprietors of the Gas Company are satisfied over the result, because it confirms the validity of their right to occupy the streets, and thus

upsets the claim of the City Engineer, who informed Sullivan & Co., in case the gas pipes interfered with the water conduits, that they (the contractors) might cut the gas pipes out. Sullivan & Co. will not appeal from the verdict of the jury; and we do not suppose they could expect to gain much by appealing to the sense of justice possessed by the City Engineer.

PUBLIC LIGHTING AT ANNAPOLIS, MD.—The authorities of Annapolis have authorized the Annapolis Gas Company to light 90 street lamps for one year, at \$18 each, burners to be of size employed in Baltimore, and hours of lighting to be based on an agreed-upon moon-table.

NEW HAVEN (CONN.) GAS SUPPLY.—Water gas is being supplied at the present time to the residents of New Haven; but the service will probably not be permanently continued. According to the *New Haven Courier* the present daily gas consumption in the city ranges between 400,000 and 450,000 cubic feet.

THE QUALITY OF OMAHA (NEB.) GAS.—Mr. Jas. Gilbert, Gas Inspector for Omaha, reports that he has been investigating the quality of gas supplied in that city pretty closely during the last seven weeks. He decides, as the result of his investigation, that "The present quality of gas condenses with too great rapidity, and, therefore, is not suited for use in cold climates." He further avers that 31 tests made in the seven weeks gave an average illuminating power of 17 candles; and that a variation of 8 candles in one 24 hours was noted by the photometer—cause, fall of 50° in temperature in less than 6 hours.

ADDING TO THE PLANT.—At the New England meeting, last February, Mr. Geo. B. Neal said it was quite likely the electric plant of the Charlestown (Mass.) Gas and Electric Light Company would soon be increased. This extension has been determined on; and, among other items, we note that the Jarvis Engineering Company, of Boston, Mass., will supply the Charlestown folks with another tubular boiler, with Jarvis boiler setting for consuming screenings for fuel, also two additional Armington & Sims' pattern of engines.

CARTHAGE (N. Y.) TO BE LIGHTED BY ELECTRICITY.—At a special charter election in the village of Carthage the taxpayers expressed their preferences (by ballot) in the matter of public lighting for the ensuing year. The result of the vote was as follows: In favor of electricity, 119; against, 97. The work of preparation to carry out the voter's wishes is now in progress.

DO THEY EXPECT TO DEFEAT THE GENERAL?—A certificate incorporating the Equitable Gas, Light and Fuel Company, of Cincinnati, Ohio, was recently filed with the Secretary of State. The capital stock is placed at \$3,000,000. Perhaps the inhabitants of the Paris of America had better hunt up the operations of the Equitable Company's various schemes in Chicago, Baltimore, Syracuse, Newark, New York, San Francisco, etc. But, come to think of it, General Hickenlooper lives in America's Paris.

CHEAPER GAS FOR DAYTON, OHIO.—Brief notice was given in our last issue of the great advance made by the managers of the Dayton Gas Light and Coke Company in the direction of the "dollar-a-thousand" winning post. The following is Secretary Smart's official announcement of the action of the Dayton Company's Board of Directors in the premises: "Resolved, That on and after April 1st, 1887, the price of gas be reduced to \$1.25 per thousand cubic feet, and a discount of 10 cents per thousand cubic feet be allowed on all bills for gas paid at the office of the Company on or before the fifth of the month, or \$1.15 net." Perhaps we could explain the way in which this action is regarded by the Daytonites in no better manner than by reproducing the following comment from the columns of the *Dayton Herald*: "This action gives Dayton the benefit of cheaper gas than any other city of its size in the Union, and clearly shows that our old reliable Gas Company means to keep abreast with the times. A little thought will show how much lower \$1.15 per 1,000 cubic feet in Dayton is than the same price in larger cities, where the day consumption is greater than the day and night consumption in Dayton; and that, too, in those cities where coal is at least 30 per cent. lower than it can be bought in this city. Under all considerations, the reduction of more than 23 per cent. in the cost of gas to the consumer is one that should be appreciated by the people. Our Dayton gas is noted all over the country as being of superior quality." The Dayton reduction offers a possible reason for Brother Joseph Light's silence at the recent Ohio meeting. He must have been indulging in "a heap of thinking," and now breaks his "golden silence" in a volume of silvery sound. Long may the Dayton Company continue to indulge in the smart practice of selling light at low figures.

CHEAPER GAS FOR BURLINGTON, IOWA.—The proprietors of the Burlington Gas Light Company have established a gross rate of \$2.25 per thousand cubic feet, but in consideration of prompt payment a discount of 25 cents is

allowed. In announcing the reduction the proprietors said: "This saving to you of one dime is the first step toward a further reduction. Help us towards that good end." To which we respond, "Amen!"

THE GAS WORKS ARE COMPLETED.—On the evening of March 26th gas was sent out from the recently completed works of the Marshall (Texas) Gas Light Company. Everything worked smoothly, and the inhabitants voted that Marshall had at last "taken her place among the cities of the State." Good enough; may they long continue to hold their gas suppliers in similar esteem. We fear, however, for what the future may reveal in that respect. Marshall starts out with 25 public street lamps, and the local plumbers are busily engaged in piping the houses of those who will shortly eschew the fatal kerosene.

BRISK COKE TRADE AT MILWAUKEE, WIS.—The Milwaukee Gas Company reports a large increase in the local trade for coke during the past winter. The most encouraging feature in the affair is that the great bulk of the demand came from those who used it for domestic purposes. Prepared coke is a cheap, cleanly and convenient fuel.

MAKING SURE OF THEIR POSITION.—It will be remembered that when the floods of last spring caused such confusion and loss in the lower portion of the city of Montreal, Can., one of the greatest annoyances sprang from the fact of the tides having put out the fires of the Ottawa street station of the Gas Company. This stoppage plunged the northern and western districts of the city in darkness; but all danger of a similar happening in the future has been averted by the placing of a main leading from the Hochelaga station to Cote Ste Antoine, along Catherine street.

CHEAPER GAS FOR MIDDLETOWN, CONN.—The directors of the Middletown Gas Light Company voted, on the last day of March, to reduce the rate for gas, from \$2.60 to \$2.10 per thousand cubic feet, a discount of 10 cents to be allowed for prompt payment. The Company has purchased a plot of land on East Court street, where an electric lighting plant is to be established. Both arc and incandescent lights will be supplied.

BROTHER SCOFIELD CONVERTS THE COUNCIL.—And every gas man knows how hard a task that is to accomplish—without resorting to the principle involved in "combines"—*a la* Jaehne, McQuade, and others. A year ago the City Council of Fort Scott, Kansas, gave a contract to the Sperry Electric Light Company to light the public lamps. Brother Scofield thereupon became a very downcast man; but as the righteous must eventually prevail, and their reward be quadrupled as recompense for the weary season of sackcloth and ashes, behold Brother S.'s victory over the wiles of the heterodox. Briefly told, the following is his reward. Shortly before the termination of the Sperry contract, which was very imperfectly performed, the Council authorized that a contract be made between the city and the Fort Scott Gas Light Company, to last for two years from first inst., under which the latter was to be paid for a total of 250 public lamps. The Gas Company, prior to the advent of the Sperry Company, was under contract to supply but 58 lamps, hence Brother Scofield's sudden admiration for the promoters of electric lighting. He closes his letter to us on the subject by remarking, "I hope to meet you all again in St. Louis next month to sympathize with those in affliction, and to rejoice with those who are happy." Not much weight of woe about the Fort Scott gas man at the present writing, and, under the circumstances, why should there be? Only 58 public lamps a year ago, and 250 now, after waiting only a twelvemonth! Well!!

MUNICH BENCHES FOR THE BOSTON GAS WORKS.—Mr. Emil Lenz is under contract to erect two benches of 6's, after the Munich system, at the works of the Boston (Mass.) Gas Light Company.

BARTLETT, HAYWARD & COMPANY HAVE PLENTY OF WORK.—Among the contracts recently made by the firm of Bartlett, Hayward & Company, of Baltimore, Md., we instance the following: Consolidated Gas Company, N. Y. City; telescopic gas holder; outer section 92 ft. 6 in., inner section, 91 ft.; sections in 26 ft. lifts; spherical crown; suspension frame of 10 wrought iron columns. This holder is to be located at 65th street and 10th avenue, and will be finished by August first. Haverhill (Mass.) Gas Light Co.; telescopic holder; outer section, 101 ft. 6 in., inner section, 100 feet ft.; sections in 26 ft. lifts; 10 wrought iron column suspension frame. Lowell (Mass.) Gas Light Company; telescopic holder; outer section, 130 ft., inner section, 128 ft.; both sections in 30 ft. lifts; 12 wrought iron column suspension frame. Standard Gas Light Company, N. Y. City; one set purifying boxes (24 by 20) complete, with centre seal, connections and covers; also, 12 large generators, with hydraulic main, stacks, etc., Worcester (Mass.) Gas Light Company; single lift holder, 63 by 20. Looking over the above list it would seem as if the present flight of birds over Chesapeake's famous waters will have nothing to fear from Brother Hayward's fowling piece—not that we mean to say he could not "fetch" the canvass-back in the latter's

flight over punt or battery; but simply because the establishment at Pratt and Scott streets will keep him from a "visit to the Bay."

OTHER WORK BEING DONE BY THE CONSOLIDATED.—In addition to the holder to be erected for the Consolidated Company, as noted in Bartlett & Hayward's contracts underway, we note that Mr. Jas. R. Floyd is to erect a set of 4 purifying boxes at the 14th street station; Mr. Thos. F. Rowland to perform a similar task at the 21st street station.

CHANGES IN THE BIRMINGHAM (ALA.) GAS FRANCHISE.—On the evening of March 30, the City Council of Birmingham approved of certain changes in the franchise for supplying gas in that city. Under a new arrangement the city is to take \$50,000 of stock in the Gas Company, and will be allowed one-half representation in the board of directors, there being six of the latter. It is stipulated that the city shall pay only \$1 per thousand for gas; private consumers, \$1.50. The prices formerly agreed upon were \$2 and \$2.50.

CHANGES AT UTICA, N. Y.—The Utica Gas Light Company and the Central New York Electric Light and Power Company have been consolidated under the name of the "Utica Electric and Gas Company." The Company is capitalized in \$300,000. The officers are Messrs. W. J. Bacon, President; E. A. Graham, Vice-President; W. P. Fish, Treasurer and General Manager; Thos. A. Mooney, Secretary; Jno. W. Bates, Engineer.

KENTUCKY GAS NOTES.—Marysville, although a small place, boasts of a pair of coal gas works. The original company was charging \$3 per thousand until last Fall, when parties from Cincinnati (Ohio) agreed to furnish gas at \$1.50. The new company (the Citizens) has been in operation about six months, and since the first of the year both companies have been selling gas at 75 cents per thousand. In October a franchise was given to Salomon Salomon, and associates, of Louisville, by the Winchester Council authorizing them to erect a gas works in Winchester, provided plant construction was begun not later than the 15th inst. Late advices say that operations have not yet commenced. Mr. Jno. Wright, who has been Superintendent of the Bowling Green Plant for many years is, we are pained to say, very dangerously ill. The sufferer is well known and universally liked by his associates throughout the State; and all will regret to hear of his precarious condition. Mr. Meyers, who, as noted some time ago in our item columns, is in charge of the model gas plant at Paducah, is busily engaged in preparing the tank for the 70-foot holder now in course of construction by Messrs. Deily & Fowler, of Philadelphia. The Henderson gas works are owned by the city, Mr. Wm. Cannings being in charge thereof. The business of gas supply has increased to such an extent that Supt. Cannings has been authorized to provide for the new conditions of things by putting up four new benches of sixes; new scrubber and condensers; a new holder; and about one mile of main pipes. He certainly will have his hands full this spring in carrying out the improvements, but, nevertheless is eager and anxious to get at work.

A BRISK TRADE.—Messrs. P. H. & F. M. Roots, of Connersville, Ind., report a decided improvement in the demand for gas exhausters. Recent shipments include a No. 2 exhauster (capacity, 250,000 cu. ft.) and engine, pipe fittings, gas and bye-pass valves, etc., to the Lafayette (Ind.) Gas Company; a No. 2 exhauster and engine to the order of Mr. Frederic Egner, of St. Louis, Mo.; and a No. 3 exhauster to the city of Mexico. They have also just received an order from the St. Louis (Mo.) Gas Light Company for an exhauster rated to pass five million cu. ft. in 24 hours. Several other negotiations are about to close successfully.

CHEAPER GAS FOR NATICK, MASS.—Supt. J. R. Todd, of the Natick Gas Light Company, has been authorized to notify the inhabitants of Natick, that the gross selling rate, from and after first inst., would be reduced from \$3 to \$2.70 per thousand cubic feet. Ordinary consumers who settle their accounts on or before the 15th day of the first month in each quarter will be entitled to a rebate of ten cents per thousand; and that rebate will be increased to 20 cents where the consumption in any one quarter reaches or exceeds 10,000 cu. ft. In the circular announcing the concession Supt. Todd calls attention to the annual cost of maintaining Ljungren lamps, burning a certain number of hours on stated days of the month—the schedule was intended to make an impression on the proprietors of business places especially—at the new gas rates. The idea is an excellent one, and cannot fail of the object intended. The Natick works were built in 1875, and the initial gas rate was \$4 per thousand. Hence it must be admitted that the Natick gas men are anxious to keep up with the procession.

ANNUAL MEETING OF THE MONTREAL GAS COMPANY.—The Fortieth annual meeting of the Montreal Gas Light Company was held on April 5th at the Ottawa street office. The President, Mr. Jesse Joseph, occupied the chair. A good attendance graced the occasion. From the annual reports read we

glean the following of interest: The net earning of the year is returned at \$240,096 46, out of which two semi-annual dividends (6 per cent. each) had been paid. The illuminating power of the gas supplied averaged 17.50 candles and the use of gas for cooking and heating has been extending. Coke has been in good demand, and the system of crushing coke has proved a success. The question of adding electric lighting to the business of the company had received attention, but no plans therefor had as yet been matured. The following extensions have been made: A coal shed at the Elm station, and a set of purifiers at the Ottawa station, besides many minor improvements in the general plant; 7,160 yards of street mains were put down; also, 454 new services. The work of putting down a new 20-inch main to supply the northern and western portions of the city is in progress. Work on the new gas holder at the Elm station is in a forward state. The old Methodist church and site, on Ottawa street, were purchased at a cost of \$14,710. The total receipts for the year were \$503,485.39. The capital stock is \$1,938,476. The plant and property are valued at \$2,035,965, and stock and materials on hand at \$254,692, with cash on hand and in bank, \$52,727. The President stated that the earnings were \$10,000 more than last year, in spite of various depressing causes, such as the introduction of the electric light in the streets, Post Office, *Gazette* office, Bank of Montreal, and elsewhere. The increase in the number of consumers was 789. The proposed gas holder would increase their daily storage capacity by one million cubic feet. It would be necessary to shortly commence the erection of a new retort house, which, with the new main and the gasholder, would entail an expenditure of over \$200,000. He (the President) called attention to the fact that it would be necessary to borrow money to meet that obligation. A shareholder (Mr. Delisle) asked if the company were poorer because of the competition of the electric light. In reply the President said, on the contrary, the consumption of gas had increased. It was moved that the stockholders authorize the management to borrow a sum not to exceed \$320,000, at an interest rate not exceeding 6 per cent. per annum, with power to issue bonds, if necessary, the money to be used in extending and paying for the facilities of the company. It was explained that, in all probability, not over \$250,000 would be required. Mr. Crawford opposed the motion, but it was finally decided in the affirmative. Mr. Crawford offered a resolution that hereafter dividends be declared quarterly instead of semi-annually, which was acquiesced in. The former board of directors was re-elected, and the meeting then adjourned. The largest single shareholder in the company appears to be the City and District Savings Bank, with a holding of 5,056 shares. The Hochelaga Bank holds 580 shares.

WILL ILLINOIS HAVE A GAS COMMISSION?—It is understood that Senator H. W. Leman will endeavor to secure the passage of a bill by the Illinois State Legislature creating a gas commission for the purpose of regulating the business of gas companies in that State. So far as known the proposed act calls for the appointment of a commission to consist of three persons; term of office, two years; salary, \$3,500.

BROUGHT INTO THE COURTS.—Advices from Chicago (Ills.), bearing date of April 8th, say that, upon application of Mr. Thos. Leaming, counsel for the American Gas Company, of Phila., Pa., the Circuit Court, on April 7th, granted an injunction restraining Mr. T. M. Avery, and others interested in the National Gas Light and Fuel Company, of Chicago, as also the Mayor and Town Council of Elgin, Ills., from tearing up the streets of that town for the purpose of supplying water gas manufactured under the Springer process. When the American Gas Company bought out the original Elgin Gas Company several weeks ago the new owners acquired an existing exclusive franchise which had been granted by the municipal authorities for a term of years. The National Company then secured the passage of another ordinance permitting competition, thus conflicting with the original company's franchise. A bond in a large sum was required to be filed, but the injunction issued restrains the approval of any bond by the Mayor, the erection of the competing works, or the publication of warnings calculated to injure the existing company's business or franchise, now owned by the American Company.

NOT SO PROSPEROUS.—From the semi-annual report to the shareholders of the Crystal Palace District (London) Gas Company, for the six months ended Dec. 31st, 1886—the report was made to the shareholders on March 18th—we learn, to use the words of the directors, "That the mild weather during nearly the whole of the last half year, the reduction in the price of gas to 2s. 9d. per thousand cubic feet, and the heavy and continued fall in the selling price of coke and tar, have produced a result on the revenue account not quite so satisfactory as usual." Nevertheless the shareholders received the following dividend awards: 3 per cent. on the preference stock; 3½ per cent. on the ordinary 7 per cent. stock; 5 per cent. on the ordinary 10 per cent. stock; and 3½ per cent. on the new ordinary 7 per cent. shares. The statement of make and disposition of gas during the half year is as follows: In store, June 30th, 2,683,000 cubic feet; made during half year,



A. M. CALLENDER & CO.,

PROPRIETORS.

Editor—JOS. R. THOMAS, C.E.

Asst. Editor—T. J. CUNNINGHAM.

Manager—C. E. SANDERSON.

PUBLISHED ON THE 2ND AND 16TH OF EACH MONTH

At No. 42 Pine Street, New York.

This is a recognized official organ of—
LIGHT, HEAT, STEAM, WATER-SUPPLY,
VENTILATION, SANITARY IMPROVEMENT,
AND GENERAL SCIENCE.

TERMS

SUBSCRIPTION—Three Dollars per annum, in advance.

AGENTS

NEW YORK—AMERICAN NEWS Co. 39 and 41 Chambers St.
BOSTON—S. M. PETTINGILL & Co., 6 State Street.
PHILADELPHIA—PRATT & Co., Corner 9th and Arch Streets.
England—C. W. HASTINGS, 22 Buckingham St., London, W C
Germany—B. WESTERMANN & Co., of New York

SATURDAY, APRIL 16, 1887.

The Manufacture of Sulphate of Ammonia from Waste Gases.

The *American Manufacturer*, in editorially commenting on the above, says that by reason of the large body of unoccupied land that can still be taken up, under our pre-emption laws, or that can be bought at a nominal figure in the West, as well as because of the cheapness of land in the older States, the question of artificial manures has not assumed the importance with us that it has in the thickly populated countries of Europe, the soil of which has been worn out by centuries of cultivation.

In these countries the attention of the communities has been directed to methods of saving the ammoniacal liquors given off in the process of gas making, or of consuming coal in large quantities in any industries—such as coke making and blast furnace operations. Quite a number of English plants have already been adapted to washing of these gases and the recovery of the ammonia and other products of the tar and liquors. So also, in some of the coking districts of England, France, Germany, and probably other countries, the waste gases generated in the manufacture of coke, in addition to being utilized in the flue ovens to aid in the carbonization of coke, have their tar and other valuable ingredients utilized.

These waste gases are chiefly used in the manufacture of sulphate of ammonia, or ammonium sulphate. A recent calculation as to the amount of gas gotten out, of ammonium sulphate produced, and the cost of producing the same by what is known as the Ginniberg apparatus, has been made. The amount of gas liquor obtained by carbonizing a certain amount of coal, at 5½ Twaddell, was about 3,500 tons, and from these

3,500 tons about 389 tons of ammonia sulphate can be produced at the following cost:

Material.	Tons.	Price.	£	s.	d.
Sulphuric acid at 60° Be.....	389	40s.	777	0	0
Lime	71	12s. 6d.	44	7	6
Labor, 4 men, 50 weeks each, at ..		25s.	250	0	0
Coal.....	175	8s.	70	0	0
Casks and packing.....			155	12	0
Sundries, repairs, etc.....			116	14	0
Depreciation on plant, £300; buildings, £150; total, £450..		@ 10 p.ct.	45	0	0
Interest on plant and buildings, £450; land, £100; total, £550..		@ 5 p.ct.	25	10	0
Gas liquor, at 5½ Tw.....	3,500	12s.	2,100	0	0

Total cost of manufacturing sulphate of ammonia..... £3,587 3 6

Taking the price of sulphate ammonia as 11s., the following figures are obtained:

	Tons.	Price.	£	s.	d.
Sulphate of ammonia obtained as above.....	389	11s.	4,279	0	0
Cost of manufacture as above ..			3,587	3	6
Profit			691	16	6

Although, as already stated, the necessity for the utilization of the waste gases from our coke ovens and blast furnaces is not as pressing as it is in England, the waste is still so enormous as to justify a careful investigation by the proprietors of these works into the methods of the recovery of the waste products. On the basis of the calculation above given, the daily waste in the Connells-ville coke region alone would be equal to the production of half of the amount of liquor assumed in the above calculation, and consequently half the amount of sulphate of ammonia, or nearly 200 tons per day.

The Market for Gas Securities.

The market for city gas shares continues dull, if not listless. Consolidated dealings are few and unimportant, little or no inquiry on the part of investment purchasers being made. Noon to-day (April 14) the bid price is 84½, holders offering at 85. Equitable is steady, and Mutual slightly weaker, although there seems to be no special reason for it. In fact Mutual looks like a purchase at current quotations. In our item columns notice is given that the proprietors of the Standard Company have made some important construction contracts with Messrs. Bartlett, Hayward & Co., and that action certainly gives color to the pale promises hitherto put forward by the Standard Company's promoters. The Brooklyn situation has a decidedly hopeful appearance, despite the fact the Griswold \$1.60 rate will eventually become a law. This measure having passed the Senate and Assembly, was supposed to be ready for the Governor, but a flaw or defect in the title was subsequently discovered, and, as we understand it, up to time of writing at least, the "flaw" has not yet been "hammered" out. The proposed commission measure does not seem to make great progress, but there is time enough left in which to hurry it up. During first week of April about 225 shares of Washington (D. C.) gas changed hands at a range of 40¼ to 41¾. Transactions included one lot of 175 shares, the holder desiring to make a bond purchase, which went into strong hands. Possibly a bid of 43 (equal to 215 on par of 100) would now fail to elicit a response. Baltimore shares are higher, Consolidated being worth 66½, and Chesapeake 81. We do not think that a mistake will be made by those who purchase at the noted figures. Equitable, of Chicago, is rated at from 88 to 90, and that security ought to afford a turn to buyers. St. Louis gas affairs are in a mixed condition, and holders of Laclède need have no fear as to the probable outcome. The Trust, to secure itself, must include that business

in its territory, and will have to pay for it. San Francisco shares are strong and higher. Boston Gas Company's shares are more likely to cross the \$1000 mark than to go back to \$850. Rumors in regard to the Chicago situation are so plentiful and varied that the safest plan is to wait for future developments.

GAS WORKS DAMAGED BY FIRE.—At 1 P.M., April 9th, sparks from a passing engine on the Syracuse & Binghamton Railroad set fire to some portion of the works of the Cortland and Homer (N. Y.) Gas Light Company. Before the flames were extinguished a loss of about \$3,000 was sustained.

PERSONAL.—Mr. Jos. Bate, formerly of Tiffin, Ohio, is now in charge of the American Gas Company's plant at Canton, Ohio. He assumed his new duties on 1st inst.

Gas Stocks.

Quotations by Geo. W. Close, Broker and Dealer in Gas Stocks.

16 WALL ST., NEW YORK CITY.

APRIL 16.

All communications will receive particular attention. The following quotations are based on the par value of \$100 per share.

	Capital.	Par.	Bid	Asked
Consolidated.....	\$35,430,000	100	84½	—
Central.....	440,000	50	30	—
“ Scrip.....	220,000	—	47	57
Equitable.....	2,000,000	100	126	128
“ Bonds.....	1,000,000	—	113	115
Harlem, Bonds.....	170,000	—	—	—
Metropolitan, Bonds...	658,000	—	110	113
Mutual.....	3,500,000	100	102	104
“ Bonds.....	1,500,000	1000	101	—
Municipal, Bonds.....	750,000	—	—	—
Northern.....	125,000	50	30	—
“ Scrip.....	108,000	—	—	—
Yonkers.....	—	50	—	80
Richmond Co., S. I.	300,000	50	50	—
“ Bonds.....	12,000	—	—	—
Gas Co's of Brooklyn.				
Brooklyn.....	2,000,000	25	105	—
Citizens	1,200,000	20	55	—
“ S. F. Bonds....	320,000	1000	—	103
Fulton Municipal.....	3,000,000	100	135	—
“ Bonds....	300,000	—	—	106
Peoples	1,000,000	10	55	—
“ Bonds.....	290,000	—	100	—
“ “	250,000	—	100	—
Metropolitan.....	1,000,000	100	82	—
Nassau.....	1,000,000	25	102	—
“ Cfts.....	700,000	1000	100	—
Williamsburgh.....	1,000,000	50	129	—
“ Bonds...	1,000,000	—	111	—
Out of Town Gas Companies.				
Boston (Mass.) Gas Co.	2,500,000	500	910	—
Buffalo Mutual, N. Y....	750,000	100	90	95
“ Bonds...	200,000	1000	95	100
Citizens, Newark.....	1,000,000	50	140	145
“ “ Bonds.	45,000	—	—	—
Chicago Gas Co., Ills...	5,000,000	25	142	145
Peoples G. L. & C. Co.,				
Chicago, Ills.....	3,000,000	—	29	31
Cincinnati G. & C. Co..	6,000,000	100	184	185
Consolidated, Balt.....	6,000,000	100	66½	—
“ Bonds....	3,600,000	—	107	107½
Chesapeake, Balt.....	1,500,000	100	80	82
“	1,000,000	—	100	102
Consumers Toronto....	1,000,000	50	194½	196½
Central, S. F., Cal.....	—	—	82	—
Capital, Sacramento, Cal.	—	—	55½	58
Hartford, Conn.....	750,000	25	140	142
Jersey City.....	750,000	20	155	—
Laclède, St. Louis, Mo.	1,600,000	100	110	112
Louisville, Ky.....	2,570,000	50	130	132
Little Falls, N. Y.....	50,000	100	95	100
“ Bonds	25,000	—	100	103
Montreal, Canada.....	2,000,000	100	209	215
New Haven, Conn.....	—	25	190	195

Oakland, Cal.....		36½	—
Peoples, Jersey City...		25	30
“ “ Bonds..		—	—
Paterson, N. J.....		25	90
Rochester, N. Y.....		50	75 80
St. Louis, Missouri.....	600,000	50	— 475
San Francisco Gas Co.			
San Francisco, Cal....	10,000,000	100	61 —
Memphis (Tenn.) Gas...	750,000	100	80 82
“ Bonds..	240,000	100	103 —
Washington, D. C.....	2,000,000	20	210 —
Wilmington, Del.....		50	205 215
Havana (Cuba) Gas Co.	3,000,000	100	18 20
“ Bonds.....	550,000	102	—

Advertisers Index.

GAS ENGINEERS.

Jos. R. Thomas, New York City.....	268
Wm. Henry White, New York City.....	268
Wm. Farmer, New York City.....	268
William Gardner, Pittsburg, Pa.....	268

GAS WORKS APPARATUS AND CONSTRUCTION.

James R. Floyd, New York City.....	271
T. F. Rowland, Greenpoint, L. I.....	271
Delly & Fowler, Phila., Pa.....	271
Kerr Murray Mfg. Co., Fort Wayne, Ind.....	262
Stacey Mfg. Co., Cincinnati, Ohio.....	271
Bartlett, Hayward & Co., Baltimore, Md.....	271
Morris, Tasker & Co., Limited, Phila., Pa.....	270
Davis & Farnum M'g Co., Waltham, Mass.....	226
R. D. Wood & Co., Phila., Pa.....	270
Southwark Foundry and Machine Co., Philadelphia, Pa.....	270
Bouton Foundry Co., Chicago, Ills.....	271

PROCESSES.

National Gas Light and Fuel Co., Chicago, Ills.....	261
---	-----

GAS AND WATER PIPES.

Gloucester Iron Works, Phila., Pa.....	268
Mellert Foundry and Machine Co., Reading, Pa.....	268
Cincinnati and Newport Iron and Pipe Co., Newport, Ky.....	268
Ohio Pipe Co., Columbus, Ohio.....	268
Pancoast & Rogers, New York City.....	268
M. J. Drummond, New York City.....	268
Wells Rustless Iron Co., New York City.....	262

GAS ENGINES.

Schleicher, Schumm & Co., Phila., Pa.....	276
Clerk Gas Engine Co., Phila., Pa.....	262

RETORTS AND FIRE BRICK.

J. H. Gautier & Co., Jersey City, N. J.....	266
B. Kreischer & Sons, New York City.....	266
Adam Weher, New York City.....	266
Laclede Fire Brick Works, St. Louis, Mo.....	266
Brooklyn Retort and Fire Brick Works, Brooklyn, N. Y.....	266
Borgner & O'Brien, Phila., Pa.....	266
James Gardner, Jr., Pittsburg, Pa.....	266
Henry Maurer & Son, New York City.....	266
Chicago Retort and Fire Brick Works, Chicago, Ills.....	266
Baltimore Retort and Fire Brick Co., Baltimore.....	266
Oakhill Gas Retort and Fire Brick Co., St. Louis, Mo.....	266
Evens & Howard, St. Louis, Mo.....	267
Cincinnati Gas Retort and Fire Brick Works, Cincinnati, O.....	267
Emil Lenz, New York City.....	267

SCRUBBERS AND CONDENSERS.

Shepard Page, New York City.....	269
----------------------------------	-----

REGENERATIVE FURNACES.

Bartlett, Hayward & Co., Baltimore, Md.....	260
---	-----

GAS GOVERNORS.

T. O. Hopper, Phila., Pa.....	264
-------------------------------	-----

CEMENTS.

O. L. Gezould, Manchester, N. H.....	266
--------------------------------------	-----

GAS ENRICHERS.

Forest City Naptha Co., Cleveland, Ohio.....	272
--	-----

GAS METERS.

Harris, Griffin & Co., Phila., Pa.....	274
American Meter Co., New York and Philadelphia.....	275
The Goodwin Gas Stove and Meter Co., Philadelphia, Pa.....	275
Helme & McIlhenny, Phila., Pa.....	275
D. McDonald & Co., Albany, N. Y.....	275
Nathaniel Tufts, Boston, Mass.....	274

EXHAUSTERS.

P. H. & F. M. Roots, Connersville, Ind.....	260
Smith & Sayre Manufacturing Co., New York City.....	270
Wilbraham Bros., Philadelphia, Pa.....	272
Connelly & Co., New York City.....	263

GAS COALS.

Peun Gas Coal Co., Phila., Pa.....	273
Perkins & Co., New York City.....	272
Newburgh Orrel Coal Co., Baltimore Md.....	273
Despard Coal Co., Baltimore, Md.....	273
Chesapeake and Ohio R. It. Coal Agency, N. Y. City.....	273
Westmoreland Coal Company, Phila., Pa.....	273
Monongahela & Peters Creek Gas Coal Co., Pittsburgh, Pa.....	273

CANNEL COALS.

Perkins & Co., New York City.....	272
J. & W. Wood, New York City.....	272

VALVES.

Ludlow Valve Manufacturing Co., Troy, N. Y.....	264
John McLean, New York City.....	264
Chapman Valve Manufacturing Co., Boston, Mass.....	264

ENGINES AND BOILERS.

Jarvis Engineering Co., Boston, Mass.....	259
---	-----

PURIFYING MATERIAL.

S. H. Douglas, Ann Arbor, Mich.....	267
-------------------------------------	-----

GAS LAMPS.

The Siemens-Lungren Co., Philadelphia, Pa.....	269
G. Shepard Page, New York City.....	232
Albo-Carbon Light Co., Newark, N. J.....	261
Standard Gas Lamp Co., Phila., Pa.....	267
Geo. H. Gregory, New York City.....	267

PURIFIER SCREENS.

John Cabot, New York City.....	267
Geo. A. Mills, Baltimore, Md.....	267

GAS STOVES.

American Meter Co., New York and Philadelphia.....	265
The Goodwin Gas Stove and Meter Co., Phila. Pa.....	240

STREET LAMPS.

J. G. Miner, Morrisania, New York City.....	260
Bartlett Street Lamp M'g Co., New York City.....	264

BURNERS.

G. Gefroerer, Phila., Pa.....	272
-------------------------------	-----

STEAM BLOWER FOR BURNING BREASE.

H. E. Parson, New York City.....	268
----------------------------------	-----

GASHOLDER TANKS.

W. C. Whyte, New York City.....	262
---------------------------------	-----

GAS FIXTURES.

Mitchell, Vance & Co., New York City.....	264
---	-----

COKE CRUSHER.

C. M. Keller, Columbus, Ind.....	273
B. J. Allen, Newark, New Jersey.....	273

COAL HANDLING MACHINERY.

C. W. Hunt Company, New York City.....	259
--	-----

GAS BAGS.

Peerless Manuf'g Co., New York City.....	259
--	-----

BOOKS, ETC.

English Journal of Gas Lighting.....	259
Gas as a Source of Light, Heat and Power.....	264
Goodwin's Directory of Gas Light Companies.....	270
The Chemist's Assistant.....	268
King's Treatise.....	274
Scientific Books.....	274
Management of Small Gas Works.....	268
Newbigglug's Gas Manager's Handbook.....	274
Gas vs. Electricity.....	262

Superintendent's Position Desired

By a practical man of twenty-five years' experience in the manufacture and distribution of coal and water gas. Satisfactory references given. Address 646-tf "ENGINEER," care this Office.

FOR SALE,

BY THE MEMPHIS GAS LIGHT COMPANY, MEMPHIS, TENN.

8 Sets Oval Mouthpieces, for 13x16 in. retorts, 4 in. stand pipes and bridge pipes. 4 Pieces Hydraulic Main, two of them 21 ft. long, 10x10 in., and the other two 8 ft. long, 10x10 in. 10 Retorts, 13x16 in., 8 ft. long. 1 Cameron Exhauster, complete and in order, with 8 in. connections. 1 Tubular Washer, 4 ft. diam. and 8 ft. high. 3 Air Condensers, 3 ft. diam. and 10 ft. high. 4 Purifiers, 10x14 ft., and 3 ft. deep. 1 Dry Center Seal, complete and in order, with 10 in. connections.

FOR SALE,

Ten No. 2 Siemens Regenerative Gas Lamps,

With Factory Fixtures and Reflectors complete and in order. Only used three or four months. Will be sold cheap.

DANVILLE NAIL AND MFG. CO.,

Danville, Pa.

GAS WORKS FOR SALE.

A RARE CHANCE.

The owner will dispose of the controlling interest in a gas works in a growing Western city, on account of declining health and inability to attend to the business. For particulars address 665-6 P. O. Box 825, Appleton, Wis.

ALBO-CARBON FIXTURES FOR SALE.

Three 12-Burner, Two 8-Burner, and Fourteen 6-Burner Clusters.

All in good order, having been used but six months. Will be sold cheap. For particulars communicate with

E. G. PRATT, Supt. N. Attleboro Gas Lt. Co., North Attleboro Mass.

FOR SALE,

Two Sinuous Friction Condensers,

Each 1 ft. 3 in. wide by 11 ft. 3 in. long, and 18 ft. high, of sufficient capacity for 225,000 cu. ft. per day. Apply to

665-12 PETER COFFEY, Supt Gas Co., Peoria, Ill.

JARVIS ENGINEERING CO.,

61 Oliver St., Boston, Mass.

CONTRACTORS FOR ERECTING

COMPLETE STEAM OUTFITS FOR ELECTRIC LIGHTING STATIONS.

Steel Boilers set with Jarvis Pat. Boiler Setting,

To burn COKE SCREENINGS for Fuel.

ARMINGTON & SIMS CO. ENGINES,

Belting direct to Dynamos, without using Shafting.

SEND FOR CIRCULARS.

REFERENCES.—Charlestown Gas & Electric Light Co., Charlestown, Mass.; Schenectady Gas & Electric Light Co., Schenectady, N. Y.; Brookline Gas Co., Brookline, Mass.

ENGLISH

"Journal of Gas Lighting."

Issued weekly. New volume commences Jan. 1, 1887. Price, \$7 per annum. Subscriptions taken by

CHARLES NETTLETON, Agent for U. S.

No. 115 BROADWAY, N. Y. CITY.

Improved Patent GAS BAG OR BLADDER VALVE.

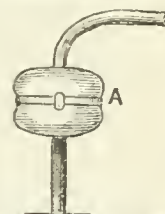

Pressure Indicator.

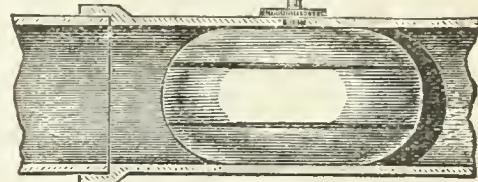

MANUFACTURED BY

PEERLESS MFG. CO., 34 Murray St., N.Y.

C. W. HUNT CO.,

No. 111 Broadway, N. Y. City.

MANUFACTURERS OF

Coal Handling Machinery,

AUTOMATIC RAILWAY, HOISTING ELEVATOR, CABLE RAILWAY, STEAM SHOVEL, HOISTING ENGINES, COAL TUBS, COAL & COKE CARS.

Plans and Specifications made for the

Erection of Coal Storage Buildings

Send for a Descriptive Pamphlet.

THE ROOTS GAS EXHAUSTER.

CINCINNATI, OHIO, March 24, 1887.

P. H. & F. M. Roots, Connersville, Ind.: Gentlemen—I have the honor to say that after the continuous and uninterrupted use of your Exhausters for a period of fifteen years, it affords me pleasure to endorse them in the highest possible terms. Very respectfully,

A. HICKENLOOPER, Prest. Cincinnati Gas Co.

CINCINNATI GAS LIGHT AND COKE CO., Cincinnati, Ohio, two No. 6 Gas Exhausters, with Engine, for their new works, which, with the two No. 6 Exhausters, without Engines, at their old works, and one No. 3, with Engine for pumping, for their station at Carthage, make five Exhausters in all for this Company.

CHICAGO, ILL., March 24, 1887.

Messrs. P. H. & F. M. Roots, Connersville, Ind.: Dear Sirs—We have two of your No. 6 Exhausters at our works, which have been running for several months, and are giving very good satisfaction. Yours truly,

THEO. FORSTALL, Prest.

THE CHICAGO GAS LIGHT AND COKE CO., Chicago, Ill., two No. 6 Gas Exhausters and Engine combined on same bed-plate.

St. LOUIS, Mo., March 21, 1887.

Messrs. P. H. & F. M. Roots, Connersville, Ind.: Dear Sirs—In 1872 one of your No. 5 Exhausters was placed in these works, and worked satisfactorily. March, 1885, it was replaced by one of your No. 6 Exhausters. The latter has been in almost constant use the past two years, has worked up to all my expectations, and is to-day in apparently as good condition as when first set up. It has not cost one cent for repairs in all that time. I have also had one of your No. 1 Exhausters, with Engine on same bed-

plate, fitted with your valves and Huutoon Governor, placed in a small works under my control, and in its operation it seems as near perfection as I ever expect an Exhauster to become. Without in the least disparaging Exhausters of other makes, I may say that your Exhauster may be safely recommended as unsurpassed by any other, to those requiring such machines. Yours respectfully,

FREDERIC EGNER, Eng. and Supt.

CLEVELAND, OHIO, March 22, 1887.

Messrs. P. H. & F. M. Roots, Connersville, Ind.: Gentlemen—Concerning the Exhauster furnished this Company by you last fall, I can say but little—indeed, much need not be said. It simply does its work perfectly, and in a way that inspires confidence that it will not shirk its duty when one's back is turned. If I wanted another 1,000,000 capacity I should try and duplicate our No. 4. Very respectfully,

EDWARD LINDSLEY, Eng. and Supt.

PEOPLES GAS LIGHT CO., Cleveland, Ohio, one No. 4 Exhauster and Engine combined on same bed-plate, Pipe Fittings, Gas and Bye-Pass Valves, Governor, etc.

INDIANAPOLIS, IND., March 21, 1887.

P. H. & F. M. Roots, Connersville, Ind.: Gentlemen—The No. 4 Exhauster and Engine which you erected for us last summer has done all you claimed for it, and has given us perfect satisfaction. Yours very truly,

JAS. SOMERVILLE, Eng. and Supt.

INDIANAPOLIS GAS LIGHT CO., Indianapolis, Ind., one No. 4 Gas Exhauster and Engine combined on same bed-plate, Pipe Fittings, Gas and Bye-Pass Valves, etc. This Exhauster has a capacity of 1,000,000 cu. ft.

P. H. & F. M. ROOTS, Patentees and Manufacturers, **CONNERSVILLE, IND.**

S. S. TOWNSEND, Gen. Agt., 22 Cortlandt St., N. Y.

COOKE & CO., Selling Agts., 22 Cortlandt St., N. Y.

To All Whom It May Concern!

The SIEMENS-LUNGREN COMPANY hereby warns the public against the use of various infringing Regenerative Gas Lamps which are offered for sale. This Company has heretofore delayed bringing suit to enjoin the manufacture or importation of such infringing lamps, solely because of the practical worthlessness of the infringing devices; and although, in each instance, they infringe some one or more of the various patents owned or controlled by this Company, they have fallen into disuse sooner than any suit could be brought to a hearing. As, however, the introduction of these infringing lamps has tended to discredit the practicability of our Company's system of regenerative gas lighting, we have instructed our Attorneys, Messrs. Geo. Harding, C. S. Whitman, and Silas W. Pettit, to give notice that legal proceedings will in future be taken against all such infringers.

THE SIEMENS-LUNGREN CO., 21st St. & Washington Av., Phila., Pa.

THE GLOBE
STREET LAMP.



MINER'S PATENT
STREET LAMPS.

Are adapted for use of Streets, Parks, Depots, Ferries, & Private Grounds.

WITH POSTS OR BRACKETS.

Jacob G. Miner,

No. 823 Eagle Ave., New York N. Y.

MUNICH REGENERATIVE FURNACE

System Drs. Schilling and Bunte.

Greatest Durability! Minimum of Attention!

COMPLETE DISTILLATION IN 3½ HOURS.

Ten to Thirteen Pounds of Coke to Hundredweight of Coal.

NO CLINKER. NO CARBONIC OXIDE IN THE REGENERATIVE FLUES.

Almost Automatic in Action.

The Most Successful Regenerative Furnace in Use.

BARTLETT, HAYWARD & CO.

Agents for the United States.

THE ALBO-CARBON LIGHT!

The Perfection of Gas Lighting.

Producing the Highest Illumination yet obtained from Gas, and

EFFECTING A SAVING IN ITS CONSUMPTION.

It has been most effective in

Replacing Electricity,

AFFORDING A

SOFT WHITE LIGHT
of **EXTREME BRILLIANCY & POWER.**

It has been most successful in

Supplanting Kerosene,

Giving Increased Light, Less Heat, and Perfect Safety

WITHOUT ADDITIONAL COST.

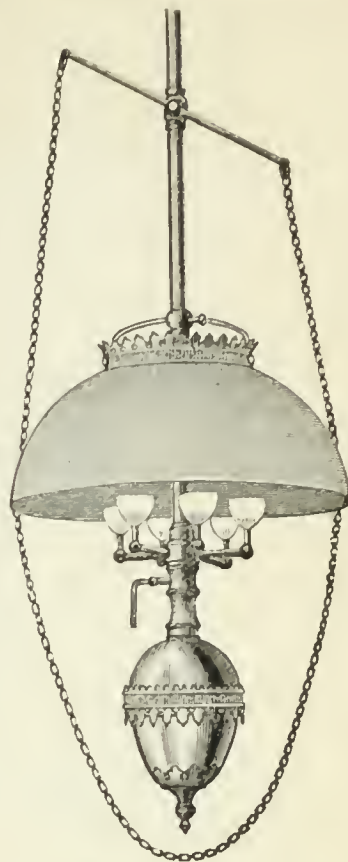
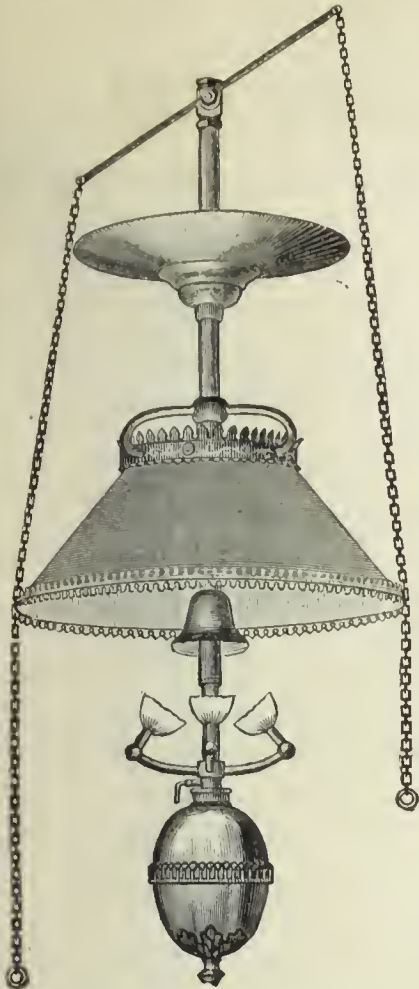

NOTICE.—Suits are pending in the United States Circuit Courts in Illinois and Pennsylvania against various parties for infringement of our Letters Patent No. 247,925, dated October 4, 1881, and No. 333,862, dated January 5, 1886. The first of these suits has come up for hearing, and an injunction has been granted therein. The second of said suits has not yet been reached for hearing. All persons are cautioned against manufacturing, selling, or using any apparatus or material which infringes our Patents. We intend to prosecute all parties infringing patents owned by us.

THE ALBO-CARBON LIGHT COMPANY, - - - NEWARK, N. J.,
Sole Manufacturers for the United States.

DURING THE PAST YEAR, THE

NATIONAL GAS LIGHT AND FUEL CO.

218 LA SALLE ST., CHICAGO,

Have Erected Twelve Sets of Water Gas Generating Apparatus under the *Springer Cupola* System. They are as follows:

- Newton Illuminating Company, Newton, Kansas.—Daily capacity, 120,000 cu. ft.
- Wellington Light & Heat Co., Wellington, Kansas.—Daily capacity, 120,000 cu. ft.
- Chippewa Falls, Gas Light Co., Chippewa Falls, Wis.—Daily capacity, 120,000 cu. ft.
- Elkhart Gas Light & Coke Co., Elkhart, Indiana.—Daily capacity, 120,000 cu. ft.
- Madison City Gas Light Company, Madison, Wis.—Daily capacity, 120,000 cu. ft.
- South Bend Gas Light Co., South Bend, Indiana.—Daily capacity, 250,000 cu. ft.
- Sheboygan National Gas Comp'y, Sheboygan, Wis.—Daily capacity, 120,000 cu. ft.
- Salina Gas Light Company, Salina, Kansas.—Daily capacity, 120,000 cu. ft.
- Rathbun Company, Deseronto, Province Ontario.—Daily capacity, 80,000 cu. ft.
- Jefferson City Gas Light Co., Jefferson City, Mo.—Daily capacity, 120,000 cu. ft.
- Mankato Gas Light Company, Mankato, Minnesota.—Daily capacity, 80,000 cu. ft.
- Minneapolis Gas Lt. & Coke Co., Minneapolis, Minn.—Daily capacity, 1,000,000 cu. ft.

1886

1886

GAS ENGINES.

GAS WORKS APPARATUS AND CONSTRUCTION.

THE CLERK GAS ENGINE CO.,

Main Office, 1012, 1014, 1016, 1018 Filbert St., Philadelphia, Pa.

WM. W. GOODWIN, Prest.

E. STEIN, Sec.

S. LEWIS JONES, Asst. Sec.

A. J. DOTY, Supt.

The utility and convenience of the Gas Engine being no longer an open question, it only remains now for intending purchasers to select the BEST. We claim for the CLERK GAS ENGINE that it is equal to any other manufactured as regards steadiness in running, simplicity, and ease of keeping in repair, and that it gives the greatest amount of power for the least money (both in first cost and expense of running) of any engine made. In support of this claim we refer to the test of the Gas Engines made under the direction of the American Institute of New York, in December, 1885, and heretofore published in these columns. These engines are especially adapted for continuous running under heavy loads, and we can refer to Engines which have run 22 hours a day for months at a time.

Made in Sizes of 5, 10, 15, 20, and 25 Horse Power. All Engines Guaranteed for One Year.

"RUSTLESS" IRON WATER PIPE.**RUSTLESS**

Send for New Catalogue.

RUSTLESS

The **WELLS RUSTLESS IRON COMPANY,**
Nos. 7 and 9 Cliff Street, New York City.

GASHOLDER TANK CONSTRUCTION, ETC.

Gas Companies and others about to erect Gasholders will find it profitable to consult W. C. WHYTE, who for over thirty years has made a specialty of

Holder Tank Excavation and Mason Work.

Fifty tanks now in operation show the sort of work done. Address

W. C. WHYTE, No. 15 Cortlandt St., N. Y. City.

GAS vs. ELECTRIC LIGHT.

We would invite attention to the able and exhaustive argument of General A. Hickenlooper, President of the Cincinnati Gas Light and Coke Company, contained in a handsome pamphlet of 96 pages, entitled

"EDISON'S INCANDESCENT ELECTRIC LIGHTS FOR STREET ILLUMINATION. REPORT OF AN ARGUMENT DELIVERED BY A. HICKENLOOPER BEFORE THE COMMITTEE ON LIGHT, MUNICIPAL COUNCIL, CITY OF CINCINNATI, JULY 22, 1886."

This is a subject of special interest to all Gas Light Companies.

Prices.

25 copies.....	\$7.50	100 copies.....	\$22.50
50 copies.....	12.50	250 copies.....	50.00

A sample copy will be sent by mail on receipt of 50 cts.
A. M. CALLENDER, & CO., 42 PINE ST., N. Y. CITY.

THE KERR MURRAY MANUFACTURING COMPANY,

Fort Wayne, Ind.

CONSTRUCTING ENGINEERS AND BUILDERS OF

GAS WORKS AND HOLDERS.

Drawings, Estimates, and Specifications Furnished for the Construction of New and the Rebuilding of Old Works.

MANUFACTURERS OF LATEST IMPROVED APPARATUS FOR COMPLETE AND AUXILIARY OIL AND WATER GAS PLANTS.

Rotary and Steam Jet Exhausters, Rotary Washers, Self-Sealing Mouthpieces,

HYDRAULIC LIFTS FOR PURIFIER COVERS.

"VALVE COMBINATION" FOR OPERATING ONE TO FOUR OR MORE PURIFIERS.

Street Specials, Valves, and Fittings.

COKE CRUSHERS, COAL AND COKE WAGONS, LAMP POSTS.

Iron Roofs, Cutters, and Retort House Floors.

STEAM ENGINES AND BOILERS, IRON COAL SHEDS.

Single and Telescopic Gasholders.

Correspondence is Respectfully Solicited.

GAS EXHAUSTERS

Have long been regarded as "luxuries" not to be thought of by small companies; but

CONNELLY'S JET EXHAUSTER IS WITHIN THE REACH OF ALL!

Will Pay for Itself in Six Months! Saves Labor! Lengthens the Lives of Retorts! Prevents the Formation of Carbon!
Increases the Yield from Twelve to Fifteen Per Cent.!

We find, after careful inquiry and investigation, that the majority of the Gas Works in the United States and Canada are running *without Exhausters*, which, in our opinion is due to two causes. *First.* The prices heretofore asked for Exhausters have been so high as to counteract, to a great extent, the advantages to be obtained from their use, and caused most managers to postpone their adoption indefinitely, or until their consumption had largely increased. *Second.* Many superintendents have a false impression that it will not pay to run an Exhauster in works producing less than 20,000 feet per day.

The first difficulty we overcome by selling our Exhausters at *extremely low prices*, as will readily be admitted after comparing our list with those of other manufacturers; and as to the second, we can say we have most convincing evidence from many companies operating our Exhausters that they can be used to advantage in works producing *as low as 6,000 cubic feet per day.*

In our improved Exhauster we combine the "Exhaust Tube" Gas and Steam Governors. Gas Compensator. and Bye-Pass Valves in the most compact form possible, which is a very great advantage to the machine, besides enabling us to manufacture and sell at the low prices given.

This is the only Exhauster in the market having a "compensator" in addition to the "gas governor"—a most important improvement, as it does away with all possible danger of their ever drawing air, and thus reducing the illuminating power of the gas.

FOR OIL GAS WORKS.

Our Exhausters are especially adapted for the use of Oil Gas Works; and where oil is required to dilute the gas a valve can be adjusted *to take the exact amount of air required*, thus dispensing with air pumps and their attendant labor and annoyance.

POINTS OF SUPERIORITY.

Requires *one-half the floor space and one-third less steam* than any other Exhauster in the market of same capacity. *More cheaply and easily connected*, as outside "Bye-Pass Valves" are dispensed with. It is the only Exhauster manufactured having "Compensator" and "Governor" *combined*, the "Compensator" with all other Exhausters being a separate and distinct machine. It is simple in construction, easily adjusted, not liable to get out of order, and *can be operated by ordinary workmen.*

NAPHTHALINE AND STEAM JET EXHAUSTERS.

As many superintendents of Gas Works believe the use of a Steam Jet Exhauster will inevitably cause trouble from *naphthaline* deposits, we recently sent out letters of inquiry to superintendents using our Steam Jet, asking for their experience, and the following replies speak for themselves. That naphthaline deposits are often unjustly attributed to Jet Exhausters is well known by many superintendents. When the cause cannot be determined it seems to be the rule to place the responsibility on the Jet Exhauster, *if they have one*; but if no Exhauster is used *the cause remains a mystery.*

OFFICE LISTOWEL GAS LT. CO., LISTOWEL, CAN., May 29, 1885.

Messrs. Connelly & Co., Ltd.: Gentlemen—The Exhauster purchased from you over three years ago, and now in use, has proven in every way all you claim for it, and has given us great satisfaction. No trouble has arisen from naphthaline.
Yours respectfully, F. W. HAY, Sec.

RICHMOND GAS CO., RICHMOND, KY, June 1, 1885.

Messrs. Connelly & Co., Ltd., 407 Broadway, N. Y.: Gentlemen—I put in your Steam Jet Exhauster last November. I think it a perfect machine, as it requires no attention whatever. Have not had any naphthaline to contend with; it would be very easy to get rid of that substance if I had it.
Yours very truly, J. B. GORDON, Supt.

HAMPTON, VA., June 3, 1885.

Messrs. Connelly & Co., Ltd.: Gents—We have been using your Steam Jet Exhauster for the past 3 years, and have never had any trouble with it whatever, either from naphthaline or any other source.
Yours truly, J. B. H. GOFF.

BRUNSWICK, ME., May 27, 1885.

Messrs. Connelly & Co., Ltd.: Dear Sirs—Your favor of 23d inst. at hand. In answer would say your Exhauster works well with us. We make an oil gas; are not troubled with naphthaline. Very truly yours, B. G. DENNISON, Prest. Brunswick Gas Lt. Co.

WILMINGTON, O., June 15, 1885.

Messrs. Connelly & Co., Ltd.: Dear Sirs—We started your make of six-inch Steam Jet Exhauster March 30, and I am pleased to state, from the time the steam was turned on, it has performed its work to our entire satisfaction. We have never had any other but a Steam Jet Exhauster, and have never been troubled with naphthaline. For many reasons I prefer it to the "rotary," and have no hesitancy in recommending it.
Yours truly, E. W. HAMLIN, Sec. Gas Co.

OFFICE LOGAN GAS LT. & COKE CO., LAGAN, HOCKING CO., O., May 29, 1885.

Connelly & Co., Ltd.: Gentlemen—In answer to yours of 27th we have to say that the Steam Jet Exhauster put in for us by you last fall has been used constantly since, and, up to this time, we have had no trouble with naphthaline. We have heard many gas men say that a Steam Set Exhauster is liable to bring on trouble with naphthaline, and we have had that fear before us; but so far we have escaped, and we trust we may not have any experience with that gas manager's bugbear.
Yours truly,
LOGAN GAS LT. & COKE CO.

OFFICE ATHENS GAS LT. CO., ATHENS, O., May 30, 1885.

Messrs. Connelly & Co., Ltd.: Dear Sirs—We take pleasure in giving you an unqualified endorsement of your Steam Jet Exhauster. It has been in place almost a year; been tested in all seasons and under all conditions; it has always proved true to the work assigned it. We have had no naphthaline deposit, nor any trouble chargeable to the Exhauster. Nothing but good has come from it, and great good at that. We can't do without it.
Very truly yours, C. H. WELCH, Supt.

OFFICE MEADVILLE GAS WORKS, MEADVILLE, PA., May 29, 1885.

Connelly & Co., Ltd.: Gents—Yours of the 27th received and contents noted. Would say that after using your Steam Jet Exhauster for the past 18 months, find it perfectly satisfactory in every way. So far as naphthaline is concerned, we have had no trouble whatever as yet.
Yours, GEO. S. CULLUM, Supt.

NYACK AND WARREN GAS LT. CO., NYACK, N. Y., May 25, 1885.

Connelly & Co., Ltd.: Gentlemen—Since your Jet Exhauster has been here there has been no trouble, and certainly *no naphthaline*. The only trouble I have experienced was the Jet becoming clogged with tar last week, and I cleaned it in a few minutes. It has run over three years without any trouble or cost for repairs.
Yours truly, A. MURRAY, Lessee and Manager.

OFFICE CADIZ GAS LT. CO., CADIZ, O., May 29, 1885.

Messrs. Connelly & Co., Ltd.: Gentlemen—Yours of 23d, inquiring how our Steam Jet Exhauster is doing, has been received. We have been using one of your Exhausters about four years, and with the best of satisfaction. We have less trouble with carbon in retorts, make more gas from same amount of coal than before, and have no trouble with stoppage in pipes or trouble from tar; and as regards naphthaline, we are not troubled with it, and do not know what it is to have any stoppage in pipes from naphthaline.
Very truly yours, A. N. HAMMOND, Sec.

SIDNEY (OHIO) GAS WORKS, June 1, 1885.

Connelly & Co., Ltd.: Gentlemen—We have now been using one of your Steam Jet Exhausters about five months, and thus far it has given us perfect satisfaction. We get a better yield and a more brilliant quality of gas from the coal. We have seen in papers and heard from different individuals that Steam Jet Exhausters were productive of naphthaline. "We can't see it," as we have found no trace of it in the works, mains, services, or meters.
Respectfully yours, W. W. GRADHAM, Supt.

CONNELLY & CO., LTD., No. 177 Broadway, New York City.

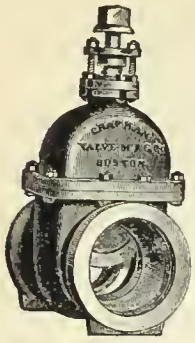

CHAPMAN VALVE MANUFACTURING CO.,

MANUFACTURERS OF

Valves and Gates for Gas, Ammonia, Water, Etc.

Also, Gate Fire Hydrants With and Without Independent Nozzle Valve. All Work Guaranteed.

WORKS & GEN'L OFFICE:
Indian Orchard, Mass.

TREASURER'S OFFICE:
72 Kilby & 112 Milk Sts, Boston, Mass.

LUDLOW VALVE MFG. CO.

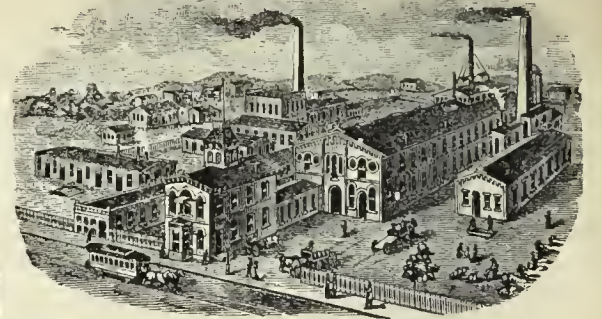

OFFICE AND WORKS,
938 to 954 River Street and 67 to 83 Vail Av.
TROY, N. Y.

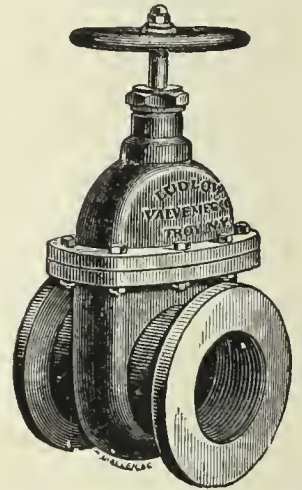

Hydraulic Main Dip Regulators, also Check Valves, Foot Valves, Yard-wash and Fire Hydrants. Send for Circulars.

Valves.—Double and Single Gate, ½ in. to 48 in., outside and inside Screws. Indicator, etc., for Gas, Water, Steam, and Oil. Send for Circulars.

T. C. HOPPER'S

AUTOMATIC DIFFERENTIAL GAS GOVERNOR

Is now in Practical Operation, doing Perfect Automatic Service with Great Precision.

This Governor will do all and more than any other Governor on the Market.

BE SURE TO THOROUGHLY INVESTIGATE THE SUPERIOR MERITS OF THIS GOVERNOR BEFORE PURCHASING.

For Simplicity and Reliable Work it has no Equal. Correspondence Solicited.

T. C. HOPPER & CO., - - Manufactory, 2227 Wood Street, Phila, Pa.

G. S. COOK, Pres. THOS. DAVENPORT (late Davenport Bros.), Sec. & Treas

BARTLETT

Street Lamp Mfg. Co.

MANUFACTURERS OF

Bartlett's Patent

GLOBE LAMPS.

FOR

Streets, Parks, Railroad Stations, Public Buildings, Etc.

LAMP POSTS A SPECIALTY.

Office and Salesroom

40 & 42 College Place, N. Y. City.

Gas Companies and others intending to erect lamps and posts will do well to communicate with us.

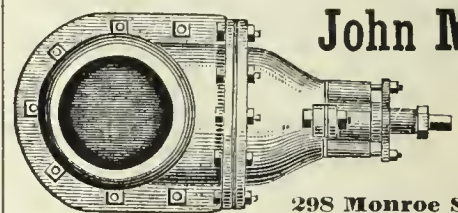
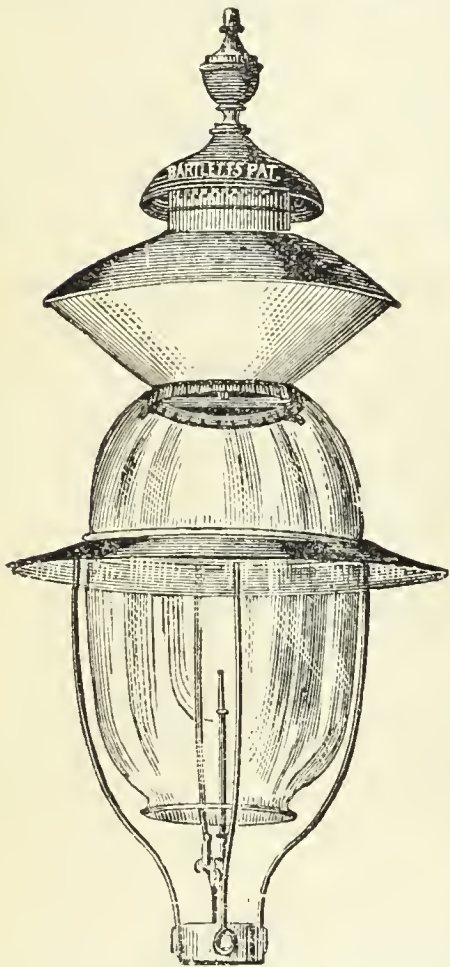

John McLean

Man'facter of

GAS VALVES.

298 Monroe Street, N. Y.

MITCHELL, VANCE & CO.,

MANUFACTURERS OF

Chandeliers

and every description of

GAS FIXTURES.

Also manufacturers of Fine Gilt Bronzes and Marble Clocks, warranted best time-keepers. Mantel Ornaments, etc.

Salesrooms, 836 Broadway, N. Y.

Special Designs furnished for Gas Fixtures for Churches, Public Halls, Lodges, etc.

GAS AS A SOURCE OF LIGHT, HEAT, AND POWER.

By C. J. R. HUMPHREYS

A Pamphlet of twenty-nine pages, treating of the use of Gas as a source of Light, Heat, and Power.

DESIGNED FOR DISTRIBUTION BY GAS COMPANIES AMONG THEIR CUSTOMERS AND OTHERS.

Price, 10 cents each, \$5 per 100, \$50 per 1,000.

Gas Companies can have their own imprint placed on cover without extra charge. All orders to be sent to

A. M. CALLENDER & CO.,

No. 42 Pine Street, N. Y. City.

GAS STOVES.

GAS STOVES.

GAS STOVES.

THE AMERICAN METER CO.,

MANUFACTORIES,

508 to 514 West Twenty-second St., N. Y.

Arch and Twenty-second St., Phila.

Nos. 244 & 246 North Wells Street, Chicago, Ill.

AGENCIES,

No. 177 Elm Street, Cincinnati, Ohio.

Nos. 122 & 124 Sutter Street, San Francisco Cal

No. 810 North Second Street, St. Louis, Mo.

NEW

INCANDESCENT

Gas Fires

AND

OPEN

Fire Place

Heaters.

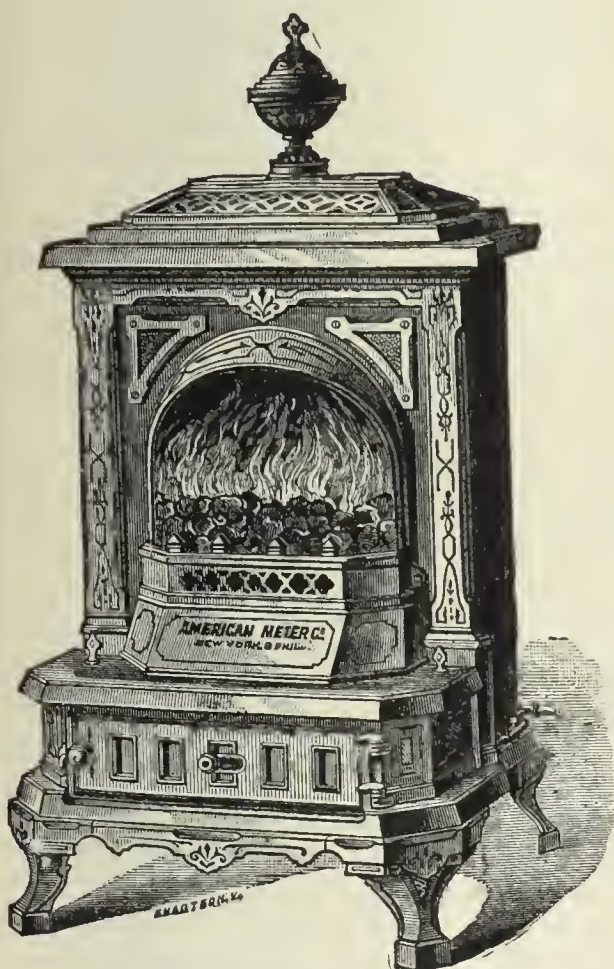

Open Fire Place Heater No. 19.
Fitted with the new Incandescent Gas Fire.

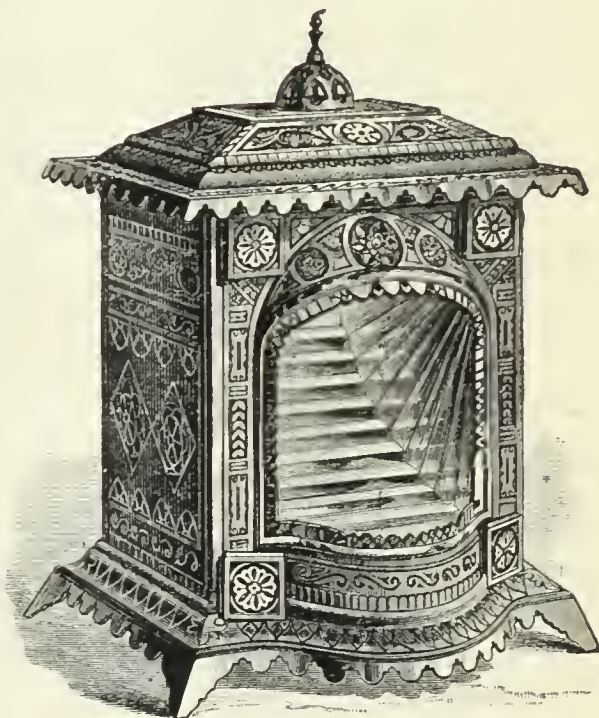

Open Fire Place Heater No. 17C.
Fitted with Illuminating Burners and Copper Reflectors.

We call attention to Special Apparatus Heated by Gas for Manufacturing Purposes.

GAS FURNACES FOR TINMEN'S USE; FURNACES FOR MELTING SOLDER AND TYPE METAL; APPARATUS FOR BENDING CARRIAGE PANELS, NOW IN SUCCESSFUL OPERATION IN CARRIAGE MANUFACTORIES; WATER HEATERS FOR KITCHEN BOILERS, BATHS, ETC., AND FOR ATTACHING TO HEATING COILS AND PIPES FOR CONSERVATORIES.

THE COMPANY MANUFACTURE

GAS STOVES FOR COOKING AND HEATING PURPOSES

In all Sizes, for Domestic, Restaurant, and Hotel Use.

These Stoves may be seen in operation at our Retail Store, No. 223 Sixth Avenue, N. Y. Call and examine.

SEND FOR CATALOGUE OF TWENTY DIFFERENT STYLES OF HEATING STOVES.

RETORTS AND FIRE BRICK.

J. H. GAUTIER & CO.,

CORNER OF

GREENE AND ESSEX STREETS,
JERSEY CITY, N. J.

MANUFACTURERS OF

Clay Gas Retorts,
Gas House Tiles,
Fire Bricks, Etc. Etc.Ground Clay, Fire Brick and
Fire Sand in Barrels.J. H. GAUTIER.
C. E. GREGORY.T. B. GAUTIER.
C. E. GAUTIER.**BROOKLYN**

Clay Retort & Fire Brick Works,

(EDWARD D. WHITE & CO.)

Manufacturers of Clay Retorts, Fire Brick,
Gas House and other Tile.VAN DYKE, ELIZABETH, RICHARD & PARTITION STS.
Office, 88 Van Dyke St., Brooklyn, N. Y.

RETORTS AND FIRE BRICK.

LACLEDE FIRE BRICK MFG. CO.,

MANUFACTURERS OF

Fire Brick, Gas Retorts,

AND

ST. LOUIS STANDARD SEWER PIPE.

Blast Furnace and Cupola Linings, every description of Fire
Clay Material, Fire Clay Flue Linings, Chimney Tops
Dry Milled and Crude Fire Clays, etc.

OFFICE AND DEPOT

901, 903, and 905 Pine Street,
ST. LOUIS, MO.

ESTABLISHED IN 1845.

B. KREISCHER & SONS,

OFFICE FOOT OF HOUSTON ST., E. R., N. Y.

Gas Retorts,**TILES, FIRE BRICK.**

AND EVERYTHING IN THE FIRE CLAY LINE.

RETORTS AND FIRE BRICK.

MANHATTAN

FIRE BRICK & ENAMELLED CLAY

RETORT WORKS.**ADAM WEBER.**

CLAY GAS RETORTS

AND RETORT SETTINGS

FIRE BRICKS, TILES, ETC.,

Office and Works, 15th Street and Avenue C., N. Y.



Works,

LOCKPORT STATION, PA.

—ESTABLISHED 1864.—

JAMES GARDNER, JR.,

Successor to WILLIAM GARDNER & SON.

Office, Rooms 19 & 20, Lewis Block,
PITTSBURGH, PA. P. O. Box 373.**Fire Clay Goods for Gas Works.**

CHAS. H. SPRAGUE & SON, No. 70 KILBY STREET, BOSTON, MASS., Agents for the New England States.

OFFICE, 418 to 422 East 23d St., New York.

ESTABLISHED 1856.

WORKS, PERTH AMBOY, NEW JERSEY.

HENRY MAURER & SON,**Excelsior Fire Brick & Clay Retort Works**

CLAY GAS RETORTS, BENCH SETTINGS, FIRE BRICK, TILES, ETC.

CHICAGO

Retort & Fire Brick Works,

OFFICE AND FACTORY,
Clark, Forty-Fifth, and La Salle Streets,
CHICAGO, ILL.

GEORGE C. HICKS, PRES. PAUL P. AUSTIN, SEC. & TREAS.

STANDARD

Clay Retorts and Settings.

BLOCKS & TILES

of every Shape and Size to Order.

Standard Fire Bricks.

GEROULD'S IMPROVED RETORT CEMENT.A Cement for patching retorts, putting on mouthpieces, and
making up all bench-work joints. This Cement is mixed ready
for use. Economic and thorough in its work. Fully warranted
to stick. For recommendations and price list addressC. L. GEROULD,
Manchester, N. H.

Western Agent, H. T. GEROULD, Mendota, Ill.

OAKHILL

GAS RETORT & FIRE BRICK

Works.

Proprietors,

PARKER-RUSSELL MINING & MFG. CO.

City Office, 711 Pine Street,

ST. LOUIS, MO.

Our immense establishment is now employed almost entirely in
the manufacture of**MATERIALS FOR GAS COMPANIES.**We have studied and perfected three important points. Our re-
torts are made to stand changes of temperature, the strongest
heats of the furnace, and the abrasion of feeding and emptying.
Our customers are in almost every State of the Union, to all of
whom we refer.

THOS. SMITH, Prest. AUGUST LAMBLA, Vice-Prest. & Sud

BALTIMORE**RETORT & FIRE BRICK CO.**

MANUFACTORY AT

LOCUST POINT, BALTIMORE, MD.

Connection with the City by Telephone.

Clay Retorts, Blocks & Tiles,

FIRE BRICK, FIRE CLAY,

AND FIRE CEMENT.

Red and Buff Ornamental Tiles and Chim-
ney Tops. Drain and Sewer Pipe (from
2 to 30 inches). Baker Oven Tiles
12x12x2 and 10x10x2.

WALDO BROS., 88 WATER ST., BOSTON, MASS

Sole Agents the New England States.

RETORTS AND FIRE BRICK.

GAS LAMPS.

LIME TRAYS.

EVENS & HOWARD,
916 Market St., St. Louis. Mo.
Works, Howard Station, Mo. Pacific R.R.

Fire Brick, Gas Retorts

AND
RETORT SETTINGS.

Sewer Pipe, 3 to 24 in. diameter.
Glass Pot Clay, Ground Fire Clay, in barrels and in bulk. All kinds of Fire Clay Goods.

Cincinnati Gas Retort & Fire Brick Works.
—ESTABLISHED 1872.—

CHAS. TAYLOR,
MANUFACTURER OF

Gas Retorts, Fire Brick, and Tile.
Blast Furnace Linings, Cupola Blocks, Boiler Tiles, Grate Settings, and Stove Linings. Fire Cement, Fire Clay, Fire Sand, and all other Fire Clay Goods.

Branch Works, New Cumberland, W. Va.
GENERAL OFFICE AND WORKS,
Burns St., Cincinnati, Ohio.

Stettiner Chamotte Fabrik Actien Gesellschaft,
Formerly **DIDIER,**
(Patentees of the Dr. Schilling & Dr. Bunte Regenerative Furnace)
STETTIN, GERMANY.

The attention of all Gas Engineers is called to our Fire-Proof Material, viz.:

CLAY GAS RETORTS
(ENAMELED AND UNENAMELED),

Blocks, Tiles.
AND

EXTRA FIRE BRICK,

Pronounced by the highest authorities as superior to and excelling any other similar manufacture. The component of aluminum contained in our material (up to 45 per cent.) is larger than in any other material heretofore sold in the United States; whilst the uniformity of the goods is assured by the most scrupulous analysis of the clay used.

For any further information and prices please apply to

EMIL LENZ,
2 & 4 Stone St., Room 19, N. Y. City.

PATENTS.

FRANKLIN H. HOUGH,
Solicitor of American & Foreign Patents

925 F. ST., WASHINGTON, D. C.

(NEAR U. S. PATENT OFFICE.)

Personal attention given to the preparation and prosecution of applications for Letters Patent. All business before the U. S. Patent Office attended to for moderate fees. No Agency in the United States possesses superior facilities for obtaining Patents, or for ascertaining the patentability of inventions. Copies of patents furnished for 25 cents each. Correspondence solicited.

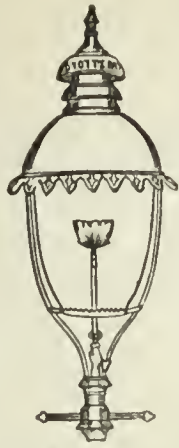

STEPHEN A. MORSE, President.
GODFREY REBMANN, Vice-Pres.

M. B. DYOTT,
Superintendent.

EDWIN F. MORSE, Secretary.
CARLTON M. WILLIAMS, Treas.

STANDARD GAS LAMP CO.,

Office, 411 Cherry St. Factory, 1101, 1103 & 1105 Frankford Av.

Philadelphia, Pa.

It is to the interest of Gas Companies and Cities to use Dyott's Patent Champion Lamps, which give double the light with the same consumption of gas, and will save 50 per cent. over others in cost of keeping in repair. Gas Companies and others intending to erect Lamps of any description will do well to communicate with us. Special Drawings furnished and Estimates given on application upon Architects', Engineers' or our Draughtsmen's Plans.

Our Patent System of Instantaneously Lighting Gas (without electricity) for R. R. Depots is unequalled. Our High Candle Power Burner is superior to the Electric Light or any other High Candle Burner. We manufacture every description of Ornamental Lamps.

WONDERFUL GAS LIGHT!

Great improvements! New inventions! Brilliant success! Brilliant light! Over 500,000 of the Gas Lamps and Burners designed by Geo. H. Gregory now in practical use. Send for Catalogue. Prices reduced on all goods in order that Gas Companies will introduce the goods to the consumer at a reasonable price. Over one hundred Gas Companies are selling the new lamps and burners. The only way to prevent the adoption of incandescent electric light is to put on the wonderful gas lamps and burners. Address **GEO. H. GREGORY, Gas Lamp and Burner Mnfr., 389 BROADWAY, N. Y.**

CHURCH'S REVERSIBLE TRAY



Patented July 9, 1878, and Feb. 5, 1884.

References in all parts of the country. Send for circular and list of companies who now have the Tray in use.

For Purifiers & Scrubbers.

VERY DURABLE!
Easily Repaired!

OVAL OR RECTANGULAR SLATS WITH MALLEABLE IRON CROSS BARS.

APPLY TO

JOHN CABOT,

306 to 310 Eleventh Ave., N. Y. City.

MILLS' REVERSIBLE LIME TRAY,

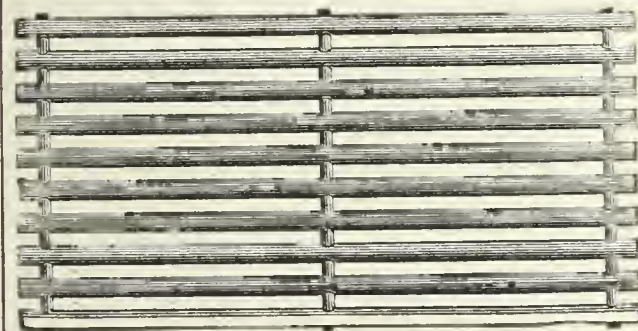

Patented July 9, 1878, and Feb. 5, 1884.

AND

WOODWORK

Of Every Description

NEEDED BY GAS WORKS.

SEND FOR CIRCULAR AND PRICE LIST TO

GEORGE A. MILLS,

Canton Av. & President St., Baltimore, Md.

Ferric Oxide for Gas Purification.

Ferric Oxide, as ground, screened, and prepared by me for purifying purposes, has now been in use for several years by many of the gas works throughout the country, including Detroit, Chicago, Milwaukee, East Saginaw, Burlington (Iowa), Ann Arbor, etc. It has proved, as I believe, the **Most Effective and Economical Agent** now in use. I am prepared to furnish the Oxide by the 100 lbs. or in car load lots, and will be pleased to give price f.o.b. cars at Ann Arbor or at place of destination. Address

S. H. DOUGLAS, Prest. Ann Arbor (Mich.) Gas Light Co.

GAS AND WATER PIPES.

GAS AND WATER PIPES.

ENGINEERS.

SAM'L R. SHIPLEY, Pres.
HENRY B. CHEW, Treas.

JAS. P. MICHELLON, Sec.
WM. SEXTON, Supt.

P. D. WANNER, Chairman. A. H. MELLERT, Sec. & Treas.

GLOUCESTER IRON WORKS,
GLOUCESTER CITY, N. J.

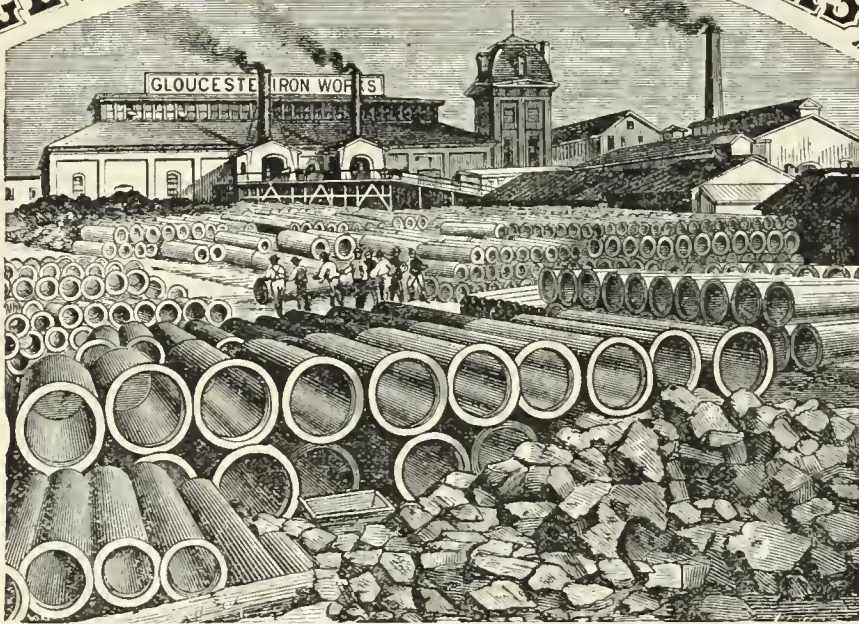

Cast Iron Gas & Water Pipes, Stop Valves, Fire Hydrants, Gasholders. &c.
Office No. 6 North Seventh Street, Philadelphia.

MATTHEW ADDY, President.

W. L. DAVIS, Selling Agent.

GEO. P. WILSHIRE, Sec. & Treas.

Cincinnati and Newport Iron and Pipe Company,
NEWPORT, KY.

Lamp Posts
AND
BENCH CASTINGS

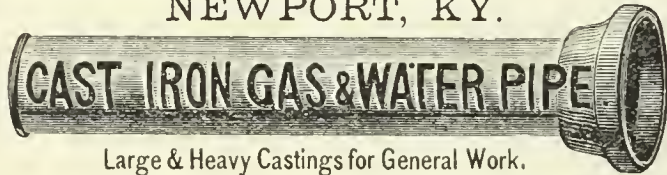

Branch
AND
SPECIAL CASTINGS

A Specialty.

Large & Heavy Castings for General Work.

FOR GAS & WATER CO'S.

Manufacture Pipe from 2 to 48 inches. All work guaranteed first quality.

Pancoast & Rogers.

WROUGHT IRON PIPE,

VALVES AND GATES,

Cast Iron Gas & Water Pipe.

28 Platt and 15 Gold St., New York.

Parson's Steam Blower,

FOR IMPROVING BAD DRAUGHT IN BOILERS, AND FOR BURNING BREEZE OR OTHER WASTE MATERIAL.

PARSON'S TAR BURNER,

FOR UTILIZING COAL TAR AS FUEL.

PARSON'S AIR JET TUBE CLEANER,

FOR CLEANING BOILER TUBES.

These devices are all first-class. They will be sent to any responsible party for trial. No sale unless satisfactory. Manufactured by the WATERTOWN STEAM BLOWER COMPANY.

H. E. PARSON, Supt., 42 PINE ST., N. Y.

The Management of Small Gas Works.

By C. J. R. HUMPHREYS. Price, \$1.

A. M. CALLENDER & CO., 42 Pine St., N. Y.

MELLERT FOUNDRY & MACHINE CO., Ltd.
Reading, Pa.



Specials—Flange Pipe, Valves and Hydrants, Lamp Posts, Retorts, etc.

General Foundry and Machine Work.

JOHN FOX, Selling Agent. 160 Broadway, N. Y.

THE OHIO PIPE COMPANY,

MANUFACTURERS OF

Cast Iron Gas & Water Pipe,

BRANCH AND SPECIAL CASTINGS.

Gas-House Bench Castings, Hydraulics, Lamp Posts, Flange Pipe and Specials, Architectural Castings, Building Columns, Joists, Cellar Grates, Sash Weights, etc.

GENERAL FOUNDERS AND MACHINISTS.

Columbus, Ohio.

M. J. DRUMMOND,



SPECIAL CASTINGS AND LAMP POSTS.
95 Liberty St., - New York.

JOS. R. THOMAS, C.E.,

May be Consulted on all Matters Relating to Gas Works and Gas Manufacture.

ADDRESS THIS OFFICE.

WM. FARMER, ENGINEER,
32 Park Place, Room 36, New York.

THE CHEMIST'S ASSISTANT; OR, KINDERGARTEN SYSTEM OF CHEMISTRY.

A system by which the elements and their valences are represented by illustrations and solid bodies.

BOX AND PAMPHLET COMPLETE, \$2.50.

WM. HENRY WHITE,
CONSULTING AND CONSTRUCTING

Gas Engineer & Contractor

Estimates, Plans, and Specifications furnished for new works or extensions of existing works.

No. 32 Pine Street, New York City.

Correspondence solicited.

WM. GARDNER,
Gas Engineer,

Lewis Block, Room 20, Pittsburgh, Pa.

Those who intend to make alterations in existing gas plants, or who contemplate the erection of new works, will find it to their interest to open correspondence with the above. Plans made and estimates furnished.

GAS LAMPS.

SCRUBBERS AND CONDENSERS.

The Siemens and Lungren REGENERATIVE GAS LAMPS.

A System of Burning Gas whereby its Illuminating Power is Increased from 300 to 400 per ct. without the Expense, Trouble and Annoyance resulting from the use of Hydrocarbon Enriching Material.

The Siemens-Lungren Company received the only Silver Medal or Highest Award for Gas Burners at the "Novelties" Exhibition of the Franklin Institute, held at Phila., Oct., '85.

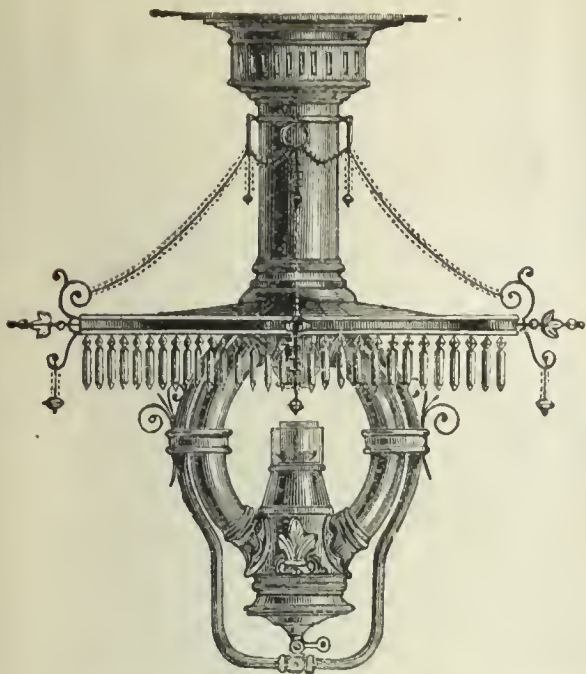

SIEMENS LAMP.

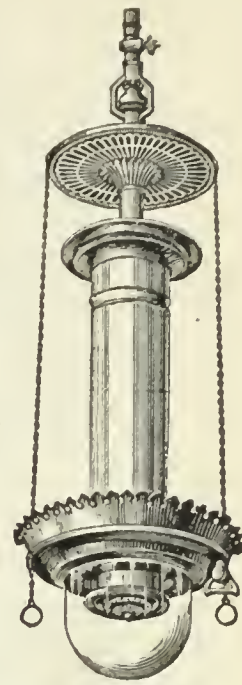

LUNGREN LAMP

THIRTEEN CANDLE POWER PER CUBIC FOOT OF GAS!

This result is obtained

SIMPLY BY THE SCIENTIFIC APPLICATION OF THE REGENERATIVE PRINCIPLE.

Consequently this largely increased illumination is always maintained without further cost and frequent attention.

THE SIEMENS-LUNCREN COMPANY,

N. E. Cor. 21st. St. and Washington Av., Phila., Pa.

THE PATENT "STANDARD" WASHER-SCRUBBER

(KIRKHAM, HULETT & CHANDLER PATENT.)

Has been adopted by gas companies in all parts of the world. Between 300 and 400 companies, with the enormous daily output of over 300,000,000 cubic feet, are now using it. "Standard" Washer-Scrubbers have been erected for the following gas light companies since Jan. 1, 1886:

WALLASEY, ENGLAND.....	750,000	cubic feet.
NEWARK, ENGLAND.....	350,000	"
BUFFALO, U. S. (MUTUAL).....	500,000	"
BERLIN, GERMANY.....	1,250,000	"
SO. BRISBANE, AUSTRALIA.....	300,000	"
LEEDS, ENGLAND.....	2,000,000	"
FURTH, GERMANY.....	400,000	"
FREIBURG, GERMANY.....	200,000	"
NINE ELMS, LONDON.....	3,000,000	"
MELBOURNE, AUSTRALIA (2).....	3,000,000	"
GLUCKAUF COKE WORKS, GERMANY.	200,000	"
BOURNEMOUTH, ENGLAND.....	1,000,000	"

RICHMOND, SURREY, ENGLAND.....	1,500,000	cubic feet.
BRIDGEPORT, U. S.....	500,000	"
TORONTO, CANADA.....	1,000,000	"
HARTFORD, U. S.....	1,000,000	"
DETROIT, U. S.....	750,000	"
SINGAPORE, CEYLON.....	300,000	"
BRUNSWICK, GERMANY.....	300,000	"
LILLE, FRANCE.....	750,000	"
CADIZ, SPAIN.....	300,000	"
READING, ENGLAND.....	2,000,000	"
LINCOLN, U. S.....	250,000	"
ST. LOUIS, U. S. (LACLEDE).....	1,000,000	"
BROOKLYN, U. S.....	2,000,000	"

That this apparatus is really the *standard* is indicated by the following names of important houses who represent this invention in the different countries of the world:

FRANCE & BELGIUM, Mons. J. A. Berly, 31 Rue Boinod, Paris. HOLLAND & DUTCH COLONIES, Mess. W. Hoven & Zoon, Rotterdam.

GERMANY and AUSTRO-HUNGARY, Berlin-Anhaltische-Actiengesellschaft, Berlin, Moabit, and Dessau.

RUSSIA, Mr. F. Bley, Galernaya, 44, St. Petersburg. SPAIN, Mess. Nicolas, Chamon, Foiret & Cie., 29 Rue Claude-Vellefaux, Paris.

ITALY & MALTA, Sig. E. Canziani, 26 & 28 Portici, Vittorio Emmanuele, Genoa. Sig. Fratelli Scheuer, Via Chiaja, 124, Naples

NEW SOUTH WALES, Messrs. W. Coward & Sons, 143 Queen Victoria St., London.

NEW ZEALAND and VICTORIA, Messrs. G. D. Jennings & Co., 28 Gracechurch St., London.

Companies in the U. S. adopting this apparatus can now be assured of a market for the Ammoniacal Liquor at a remunerative price. Correspondence for purchase of "Standards" and Ammoniacal Liquor is solicited by the

GEO. SHEPARD PAGE, 69 WALL STREET, NEW YORK.

GAS WORKS APPARATUS AND CONSTRUCTION.

GAS WORKS APPARATUS AND CONSTRUCTION.

WORKS: { MILLVILLE, N. J.
FLORENCE, "
CAMDEN, "

R. D. WOOD & CO.,

OFFICES: { 400 CHESTNUT ST.,
PHILADELPHIA.

GAST-IRON PIPE 1½ to 72 Inches in Diameter.

Water Machinery and Gas Apparatus.

HEAVY CASTINGS.

HOLDERS,

PURIFIERS,

FLOORS AND ROOFS,

LAMP POSTS,

CONDENSERS,

FLANGED PIPE,

VALVES,

BENCH WORK,

FIRE HYDRANTS,

METER CASES.

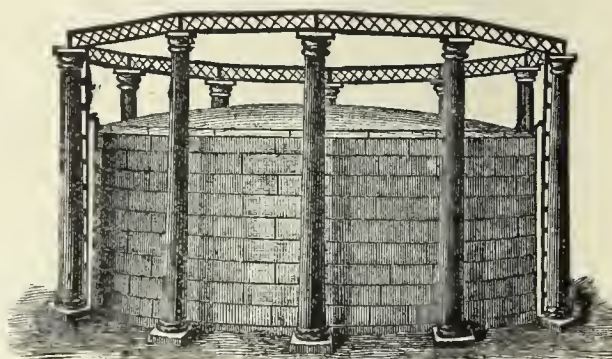

Estimates and Specifications for
NEW WORKS or **EXTENSIONS**
or **ALTERATIONS** of **OLD ONES.**

SMITH & SAYRE MFG. COMPANY,

G. G. PORTER, Prest.

245 Broadway, N. Y.

CHAS. W. ISBELL, Sec'y.

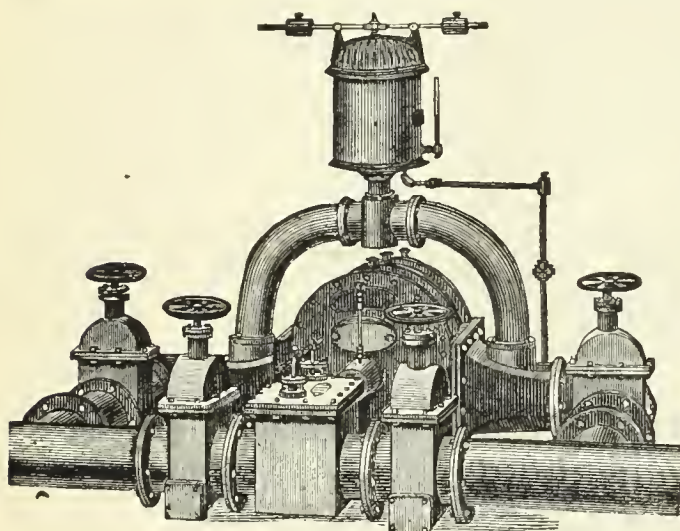

Machinery & Apparatus for Gas Works

Drawings, Plans, and Estimates Furnished for the Improvement, Extension, or Alteration of Gas Works, or for the Construction of New Works.

Mackenzie's Patent Rotary and Steam Jet Gas Exhausters, Governors, Compensators, Condensers, Washers, Scrubbers. Isbell's Patent Automatic Street Pressure Governor, Gas and Water Valves, Hydraulic Main Dip Regulator, Bench Castings, etc. Purifying Boxes and "Standard" Scrubbers. Isbell's Patent Self-Sealing Retort Doors.

SOUTHWARK FOUNDRY AND MACHINE COMPANY,

Successors to MERRICK & SONS,

GAS APPARATUS,

Holder, Purifiers, Washers, Etc., Etc. Boiler and Tank Work. Steam Engines. Hydraulic Machinery. Bessemer Plants, Etc.

Washington Ave. and Fifth Street, Philadelphia, Pa.

MORRIS, TASKER & CO.,

Limited,

Builders of Gas Works,

PHILADELPHIA PA.

GOODWIN'S DIRECTORY

OF THE

GAS LIGHT COMPANIES OF THE UNITED STATES & CANADA

Price, \$10.00.

Orders may be sent to

A. M. CALLENDER & CO., No. 42, Pine Street, N. Y. City.

GAS WORKS APPARATUS AND CONSTRUCTION.

GAS WORKS APPARATUS AND CONSTRUCTION.

JAMES R. FLOYD,

(SUCCESSOR TO HERRING & FLOYD)

Oregon Iron Works,

531 to 543 West 20th St., N. Y.

Practical Builders of Gas Works,

MANUFACTURERS OF

ALL KINDS OF CASTINGS
AND

APPARATUS FOR GAS-WORKS.

BENCH CASTINGS

from benches of one to six Retorts each.

**WASHERS: MULTITUBULAR AND
AIR CONDENSERS; CONDENSERS;
SCRUBBERS**

(wet and dry), and

EXHAUSTERS

for relieving Retorts from pressure.

BENDS and BRANCHES

all sizes and description.

FLOYD'S PATENT
MALLEABLE RETORT LID.

PATENT

SELF-SEALING RETORT LIDS.

FARMER'S

PATENT BYE-PASS DIP-PIPE.

SABBATON'S PATENT

FURNACE DOOR AND FRAME.

BUTLER'S

COKE SCREENING SHOVELS.

GAS GOVERNORS,

and everything connected with well regulated Gas Works at low price, and in complete order.

SELLER'S CEMENT

for stopping leaks in Retorts.

N. B.—STOP VALVES from three to thirty inches—
at very low prices.

Plans, Specifications, and Estimates furnished.

Bouton Foundry Co.,

FOUNDERS AND MACHINISTS,

CHICAGO, ILL.

Gas Works Apparatus,

PURIFIERS, CONDENSERS,

Bench Work,

SPECIALS, LAMP POSTS,

SCRUBBERS,

Iron Roofs and Floors.

Plans and Estimates furnished for new works or extensions of old works.

BOOKS.

DISTILLATION OF COAL TAR AND
AMMONIACAL LIQUOR.

By GEORGE LUNGE. Price \$8.50.

A TREATISE ON THE COMPARATIVE
COMMERCIAL VALUES OF GAS
COALS AND CANNELS.

By DAVID A. GRAHAM. 8vo., Cloth. Price \$3.

Orders for these books may be sent to this office.

A. M. CALLENDER & CO.,

42 PINE ST., N. Y. CITY.

CONTINENTAL WORKS.

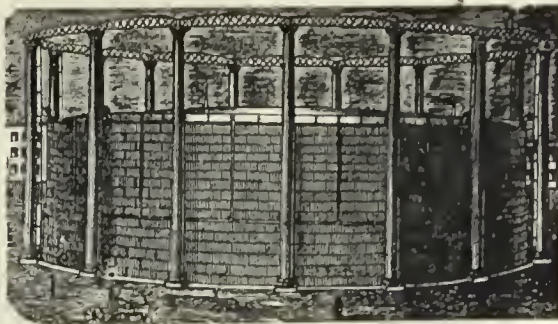

GASHOLDERS OF ANY MAGNITUDE.

T. F. ROWLAND, Proprietor,

GREENPOINT, BROOKLYN, N. Y.

ENGINEER AND MANUFACTURER OF

GAS-HOLDERS.

CONDENSERS, SCRUBBERS, VALVES,

PURIFIERS, RETORTS, and HY-

DR АуLIC MAINS,

and all other articles connected with the Manufacture and Distribution of Gas. Plans and Specifications prepared and Proposals given for the necessary Plant for Lighting Cities, Towns, Mansions, and Manufactories.

H. RANSHAW, Prest. & Mangr. WM. STACEY, Vice-Prest. T. H. BIRCH, Asst. Mangr. R. J. TARVIN, Sec. & Treas.

STACEY MFG. CO.,

MANUFACTURERS OF

Single and Telescopic Gasholders,

IRON ROOFS, BRIDGES, LAMP POSTS,

Water and Oil Tanks, Coal Elevator Cars,

COKE CRUSHERS, BENCH CASTINGS,

And all kinds of Wrought and Cast Iron Work used in the erection of Coal and Oil Gas Works, Rolling Mill Machinery and Heavy Castings a Specialty.

Foundry:

33, 35, 37 & 39 Mill Street.

Wrought Iron Works:

16, 18, 20, 22, 24 & 26 Ramsey Street.

Cincinnati, Ohio.

BARTLETT, HAYWARD & CO.,

Office, German & Calvert.

BALTIMORE, MD.

Works, Pratt & Scott.

PURIFIERS.
Roofs.
Bench Castings.

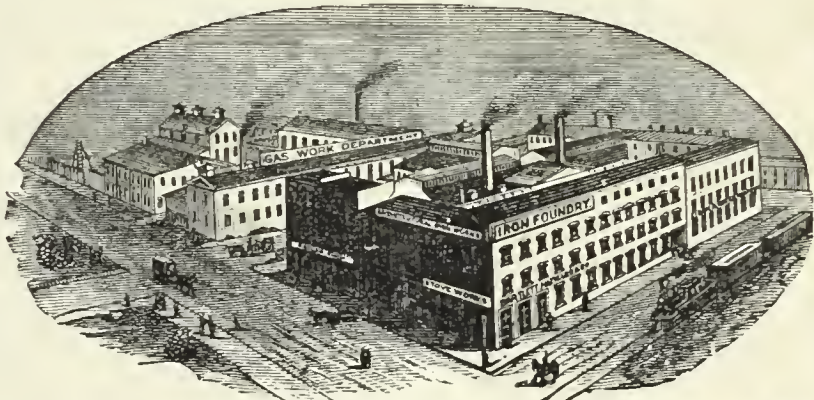

CONDENSERS.
BOILERS.
SCRUBBERS.

GASHOLDERS.

CONSTRUCTING ENGINEERS AND BUILDERS OF GAS WORKS.

1842. **DEILY & FOWLER,** 1887.

Laurel Iron Works.

Address, No. 39 Laurel Street, Philadelphia, Pa.

MANUFACTURERS OF

GASHOLDERS,

Single or Telescopic, with Cast or Wrought Iron Guide Frames.

HOLDERS BUILT SINCE 1881:

Scranton, Pa. (2d)
West Point, N. Y.
Fitchburgh, Mass.
New London, Conn.
Derby, Conn.
Bridgeport, Conn.
Allegheny, Pa. (1st.)
St. Hyacinth, Can.
Norwalk, O.
Brattleboro, V.
Waltham, Mass. (2d.)
West Chester, Pa.
Baltimore, Md.

Hollidaysburg, Pa.
Galveston, Texas (2d.)
Marlboro, Mass.
Denver, Col.
Chicago, Ill. (West Side).
Pittsburgh, Pa. (S. Side).
Pawtucket, R. I.
Brookline, Mass.
Sherbrooke, Can.
Burlington, N. J. (2d.)
Bridgeton, N. J.
Bay City, Mich.
Erie, Pa.

Jackson, Mich.
Kalamazoo, Mich. (3d.)
Glen Island, N. Y.
Warren, Ohio.
Bath, N. Y.
Lynn, Mass.
New Bedford, Mass.
Waterbury, Conn.
Deseronto, Can.
Hoosic Falls, N. Y. (2d.)
Bethlehem, Pa.
Atlanta, Ga. (1st.)
Savannah, Ga.

Montgomery, Ala.
Newport, R. I.
Portland, Oregon.
Allegheny, Pa. (2d.)
Atlanta, Ga. (2d.)
N.Y.Cty (Central Gas Co)
Lynchburg, Va. (2d.)
Saylesville, R. I.
Rondout, N. Y.
Atlantic City, N. J.
Augusta, Ga.
Waltham, Mass. (2);
Mahanoy City, Pa.

New Castle, Pa.
Long Island City, N. Y.
Macon, Ga.
York, Pa.
Chester, Pa.
Hazleton, Pa. (2d.)
Novelties Exhib., Phila
Staten Island, N. Y.
Saugerties, N. Y.
Clinton, Mass. (Lau. Mills)
Chattanooga, Tenn.
Galveston, Texas. (3d.)
Omaha, Neb.

GAS COALS.

GAS ENRICHERS.

EXHAUSTERS.

JAMES D. PERKINS.

PERKINS & CO.,

F. SEAVERNS.

General Sales Agents for

The Youghioghenny River Coal Company's**OCEAN MINE YOUGHIOGHENY GAS COAL.**

The Coal from the Ocean Mine (recently operated by *Messrs. W. L. Scott & Co.*, of Erie, Pa.,) is now used by all the leading Gas Companies in the United States from Maine to Texas, and is recognized as *the only reliable Youghioghenny Gas Coal.* (See Map on p. 87 of this Journal, Feb. 16, '85.)

P. O. Box 3695,
New York**PERKINS & CO., 228 and 229 N. Y. Produce Exchange.**BEAVER STREET
ENTRANCE.**BRECKENRIDGE CANNEL,
OF KENTUCKY.**

This Colliery was re-opened in June, 1886, since which date the Cannel has been delivered to over sixty of the leading Gas Companies in this country and in Europe. As an enricher ONE TON of this Cannel will do the work of TWO TONS of any other available Cannel, and is more economical than Naptha or Oil of any character. It can be delivered in parcels of one car load or more to any point in the United States or Canada.

(See AMERICAN GAS LIGHT JOURNAL, June 16, '86, pp. 346-7.)

P. O. Box 3695,
New York.**PERKINS & CO., 228 and 229 N. Y. Produce Exchange**BEAVER STREET
ENTRANCE.**JAMES & WILLIAM WOOD,****Gas and Cannel Coal Contractors,**

No. 40 St. Enoch Sq., Glasgow. No. 2 Talbot Court, London.

Proprietors of the **BATHVILLE COLLIERIES** (which produce the celebrated **BOGHEAD CANNEL**), Shields, Shieldmuir, Drumpeller, and other Collieries. This Firm offer

STANDARD CANNELS,**Unequaled as Gas Enrichers.**

Analyses, prices, and all further information furnished on application to

Agency for U. S., Room 93, Nos. 2 & 4 Stone St., N.Y. City.O. J. BENHAM,
President.C. M. HIGGINS,
Secretary.L. H. SEVERANCE,
Treasurer.**The Forest City Naptha Co.,**

REFINERS OF

Red Crown Brand**NAPTHA AND GASOLINES.**

ALSO MANUFACTURERS OF

**A Special Grade of Naptha for
Gas Companies****FOR ENRICHING COAL GAS.**

Correspondence solicited.

No. 43 Euclid Avenue, Cleveland, Ohio.

To Gas Companies.We make to order **CAP BURNERS** to burn any amount under a stated pressure. Send for samples.Also, **SERVICE CLEANERS, DRIP PUMPS, and STREET MAIN PROVING APPARATUS.****C. A. GEFRORER,**

248 N. 8th Street, Phila., Pa.

The Wilbraham Gas Exhauster,**"BAKER SYSTEM,"**

WITH ENGINE ATTACHED, ON SAME BED PLATE OR WITHOUT.

Best, Cheapest and Most Durable Exhauster known.**WILBRAHAM BROS.,**

No. 2320 Frankford Avenue, Philadelphia, Pa.

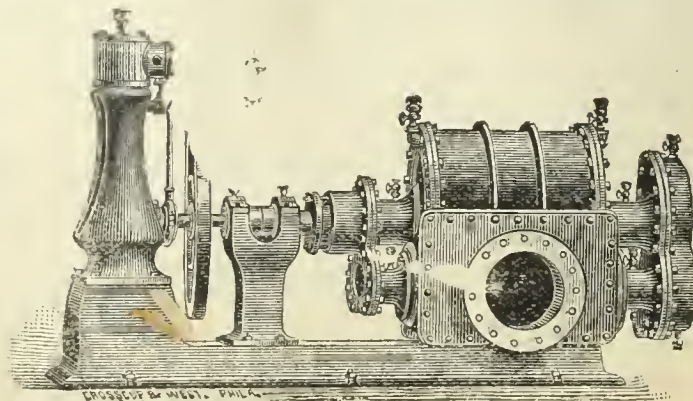

COKE CRUSHERS.

GAS COALS.

GAS COALS.

Newburgh Orrel Coal Co.,

MINERS AND SHIPPERS OF

Mountain Brook Steam and Smithing Coals,

AURORA, TYRCONNELL & PALATINE GAS COALS.

Foundry & Crushed Coke Shipped Direct from Ovens

Mines Situated at

Newburgh, Flemington & Fairmont, W.Va.

HOME OFFICE,

33 S. Gay St., Baltimore.

CHAS. MACKALL, Gen. Mangr.

CHAS. W. HAYS, Agent in New York,

Room 147, WASHINGTON BUILDING, No. 1 Broadway.

Shipping wharves at Locust Point, Baltimore.

THE DESPARD COAL COMPANY

OFFER THEIR SUPERIOR

DESPARD COAL

To Gas Light Companies and Manufacturers of Fire Clay Goods Throughout the Country.

ROUSSEL & HICKS, } AGENTS. { BANGS & HORTON, }
71 Broadway, N. Y. } 16 Kilby St., Boston. }

Mines in Harrison Co., West Va. Wharves, Locust Point, Balt.

Company's Office, 15 German St., Baltimore, Md.

Among the consumers of Despard Coal we name: Manhattan Gas Light Co., N. Y.; Metropolitan Gas Light Co., N. Y.; Jersey City, (N. J.) Gas Light Co.; Washington (D. C.) Gas Light Co.; Portland (Maine) Gas Light Co. Reference to them is requested.

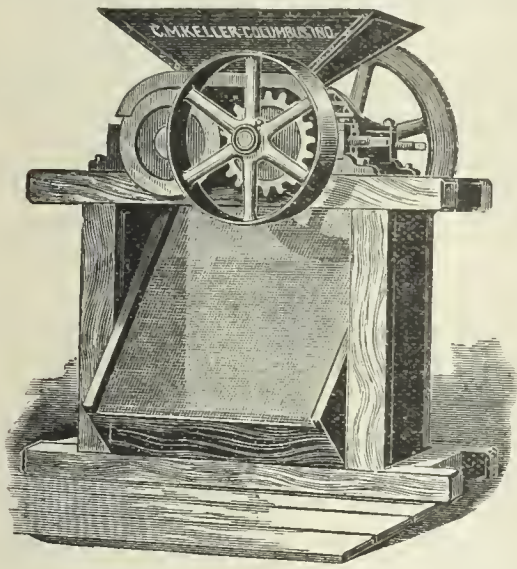

Keller's Adjustable Coke Crusher.

SIMPLE, STRONG, AND DURABLE.

C. M. Keller, Sec. & Supt. Gas Lt. & Coke Co. Columbus, Ind.

Correspondence Solicited.

GAS COMPANIES, ATTENTION!

Increase the demand for Coke by using the

Star Coke Breaker.

SIMPLE, CHEAP, DURABLE. EASILY SHARPENED BY ANY BLACKSMITH.

B. J. ALLEN, Newark Gas Co., Newark, N.J.

King's Treatise on Coal Gas.

The most complete work on Coal Gas ever published

Three Vols. Bound, \$30.

A. M. CALLENDER & CO., 42 Pine St., N. Y.

THE **PENN GAS COAL CO.**

OFFER THEIR

Coal, Carefully Screened & Prepared for Gas Purposes.

Their Property is located in the Youghiogheny Coal Basin, near Irwin and Penn Stations on the Pennsylvania Railroad, and on the Youghiogheny River.

Principal Office:

209 SOUTH THIRD STREET, PHILA., PA.

Points of Shipment:

Pennsylvania Railroad Piers; Greenwich Wharves, Delaware River; Pier No. 1 (Lower Side), South Amboy, N. J.

Chesapeake & Ohio Railway Coal Agency,

FOR THE SALE OF THE

Superior Kanawha Gas Coals, Cannelton Cannel, Also, SPLINT AND STEAM COALS.

From the Kanawha and New River Regions, on the line of the Chesapeake & Ohio R'way.

C. B. ORCUTT, Sales Agent. | OFFICE, 150 BROADWAY, N. Y.

FRANCIS H. JACKSON, Prest. EDMUND H. MCCULLOUGH, V.-Prest. CHAS. F. GODSHALL, Treas. H. C. ADAMS, Sec.

THE WESTMORELAND COAL CO.

Chartered 1854.

Mines situated on the Pennsylvania and the Baltimore and Ohio Railroads, in Westmoreland County, Penn.

POINTS OF SHIPMENT:

PHILADELPHIA, BALTIMORE, SOUTH AMBOY, N. J., WATKINS (SENECA LAKE), N. Y.

Since the commencement of operations by this Company its well-known Coal has been largely used by the Gas Companies of New England and the Middle States, and its character is established as having no superior in gas giving qualities, and in freedom from sulphur and other impurities.

Principal Office, 224 South 3d St., Phila., Pa.

A. M. SCOTT, PRESIDENT. A. DEMPSTER, C.E., SECRETARY. W. K. GILLESPIE, TREASURER.

MONONGAHELA AND PETERS CREEK GAS COAL CO.,

PRODUCERS OF

Coal Bluff Gas Coal.

MINES LOCATED ON THE MONONGAHELA DIVISION OF THE PENNSYLVANIA RR., IN THE CENTRAL PORTION OF THE PITTSBURGH COAL FIELD.

Points of Shipment—Buffalo, Cleveland, Erie, Chicago, New Orleans.

Since the introduction of Coal Bluff Gas Coal it has taken rank among the few first-class Gas Coals, and acknowledges no superior in gas-giving qualities, ease of working, quality of coke, and freedom from impurities.

Milwaukee Agents, F. R. BUELL & CO., - - - Milwaukee, Wis.

General Office, 43 Sixth Ave., Pittsburgh, Pa.

GAS METERS.

GAS METERS.

GAS METERS.



INTERNATIONAL--1876--EXHIBITION.

The U. S. Centennial Commission

HAVE DECREED AN AWARD TO

HARRIS, GRIFFIN & CO.,

Twelfth and Brown Streets, Philadelphia, Pa. No. 49 Dey Street, N. Y. City, and No. 75 North Clinton Street, Chicago, Ill.

FOR THE FOLLOWING REASONS:

The Exhibit consists of a Series of METERS from the Largest Size Station Meters for the use of the MANUFACTURE OF GAS, to those for the use of the ORDINARY CONSUMER. The Instruments are WELL MADE, RELIABLE as to INDICATION, and embody a number of sundry improvements which, with the general character of the Exhibit, entitle the whole to commendation.

Attest—J. L. CAMPBELL,
Secretary, pro-tem.

Signed—A. T. GOSHORN,
Director General

J. R. HAWLEY,
President

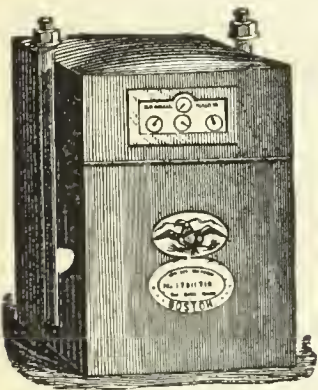

Dry Gas Meter.

With 39 years' experience and the best facilities for manufacturing, is enabled to furnish reliable work and answer orders promptly.

NATHANIEL TUFTS,

No. 153 Franklin Street, Boston, Mass.,

MANUFACTURER OF

DRY GAS METERS.

Station Meters of any Capacity.

Test and Experimental Meters, Pressure Registers, Pressure Gauges, Pressure and Vacuum Gauges.

METER PROVERS, PHOTOMETERS, STREET LANTERNS, ETC., ETC.

Patent Cluster Lanterns for Street Illumination.

SCIENTIFIC BOOKS.

We are prepared to furnish to Gas Managers, and others interested in the topics treated of, the following books, at prices named:

KING'S TREATISE ON THE MANUFACTURE OF COAL GAS. Three vols.; \$10 per vol.	PRACTICAL TREATISE ON HEAT, by THOMAS BOX. Second edition. \$5.	THE GAS MANAGER IN THE LABORATORY, by a Practical Student. 8vo., Cloth. \$1.50.
GAS MANUFACTURE, by WILLIAM RICHARDS. 4to., with numerous Engravings and Plates, in Cloth binding. \$12.	GAS WORKS—THEIR ARRANGEMENT, CONSTRUCTION, PLANT, AND MACHINERY. \$8.	THE DOMESTIC USES OF COAL GAS, AS APPLIED TO LIGHTING, by W. SUGG. \$1.40.
THE GAS ANALYST'S MANUAL, by F. W. HARTLEY. \$2.50.	COAL; ITS HISTORY AND USE, by PROF. THORPE. \$3.50.	DISTILLATION OF COAL TAR AND AMMONIACAL LIQUOR by GEO. LUNGE. \$8.50.
TECHNICAL GAS ANALYSIS. \$2.80.	THE GAS WORKS OF LONDON, by COLBURN. 60 cents.	A TREATISE ON THE COMPARATIVE COMMERCIAL VALUES OF GAS COALS AND CANNELS, by D. A. GRAHAM 8vo., Cloth. \$3.
GAS MANAGER'S HANDBOOK, by THOS. NEWBIGGING. \$4.80.	THE GAS FITTER'S GUIDE, Showing the Principles and Practice of Lighting with Coal Gas, by JOHN ELDRIDGE. 40 cents.	GAS AS A SOURCE OF LIGHT, HEAT, AND POWER, by C. J. R. HUMPHREYS. 10 cents.
GAS CONSUMER'S GUIDE. \$1.	GAS WORKS, AND MANUFACTURING COAL GAS, HUGHES. \$2.20.	GAS COMPANIES DIRECTORY. \$10.
A GUIDE TO GAS LIGHTING. 40 cents.	THE MANAGEMENT OF SMALL GAS WORKS, by C. J. R. HUMPHREYS. \$1.	GAS VERSUS ELECTRIC LIGHT. 50 cents.
GAS MEASUREMENT AND GAS METER TESTING, by F. W. HARTLEY. \$1.00	MANUAL FOR GAS ENGINEERING STUDENTS, by D. LEE, 40 cents.	PURIFICATION OF COAL GAS, by R. P. SPICE. 8vo. \$3.
GAS CONSUMER'S HANDBOOK, by WILLIAM RICHARDS, C.E.; 18mo., Sewed. 20 cents.	HOW TO MANAGE GAS, by F. WILKINS. Paper. 20 cents.	
A PRACTICAL TREATISE ON GAS AND VENTILATION with Special Relation to Illuminating, Heating, and Cooking by Gas, by E. E. PERKINS. \$1.25.		

The above will be forwarded by express, upon receipt of price. We take especial pains in securing and forwarding any other Works that may be desired, upon receipt of order. All remittances should be made by check, draft, or post office money order.

A. M. CALLENDER & CO., No. 42 Pine Street, New York.

KING'S TREATISE ON COAL GAS.

The most complete work on Coal Gas ever published. Three vols., bound \$30.

A. M. CALLENDER & CO., No. 42 Pine Street, New York.

GAS METERS.

GAS METERS.

GAS METERS.

T. C. HOPPER, Pres. G. J. McGOURKEY, Vice-Pres. (New York). WM. N. MILSTED, Gen. Supt. & Treas. (New York). WM. H. DOWN Sec.

AMERICAN METER COMPANY,

WET AND DRY GAS METERS.

PRESSURE REGISTERS.

METER PROVERS.

STATION METERS.

PRESSURE & VACUUM REGISTERS.

PORTABLE TEST METERS.

EXHAUSTER GOVERNORS.

PRESSURE & VACUUM GAUGES.

EXPERIMENTAL METERS.

DRY CENTRE VALVES.

CRESSON GAS REGULATORS.

AMMONIA TEST METERS.

GOVERNORS FOR GAS WORKS.

MARSLAND WATER METERS.

BAR AND JET PHOTOMETERS.

Manufactories:

512 W. 22d St., N. Y.
Arch & 22d Sts., Phila.

GAS STOVES,

SUGG'S "STANDARD" ARGAND BURNERS,
SUGG'S ILLUMINATING POWER METER,
Wet Meters, with Lizar's "Invariable Measuring" Drum.

Agencies:

177 Elm Street, Cincinnati.
244 & 246 N. Wells Street, Chicago.
810 North Second Street, St. Louis.
122 & 124 Sutter St., San Francisco.

HELME & McILHENNY,

(Successors to Harris & Brother. Established 1848.)

GAS METER MANUFACTURERS,

CONTINUE AS HERETOFORE AT THE OLD ESTABLISHMENT,

Nos. 1339 to 1349 Cherry Street, Philadelphia, Pa.,

To Manufacture Wet and Dry Gas Meters, Station Meters, Experimental Meters, Meter Provers, Center Seals, Pressure Registers
GOVERNORS, INDICATORS, PHOTOMETERS, & ALL OTHER KINDS OF APPARATUS FOR USE IN GAS WORKS.

From our long practical experience of the business, and from our personal supervision of all work, we can guarantee all orders to be executed promptly and in every respect satisfactorily.

WM. WALLACE GOODWIN, Prest. and Treas.

WM. H. MERRICK, V.-Prest.

S. L. JONES, Sec.

S. V. MERRICK, Supt.

THE GOODWIN GAS STOVE AND METER COMPANY,

Successors to W. W. GOODWIN & CO.

1012, 1014 and 1016 Filbert St., Phila., Pa. 142 Chambers St., New York.
76 Dearborn St., Chicago, Ill.

WALDO BROS., Agents, 88 Water St., Boston.

MANUFACTURERS OF THE "SUN DIAL" GAS STOVES, FOR COOKING AND HEATING PURPOSES.

Dry and Wet GAS METERS, Station Meters (Square, Cylindrical or in Staves) Glazed Meters, King's and Sugg's Experimental Meter Lamp Post Meters, Etc., Etc., Meter Provers (sizes 2, 5 and 10 feet), Pressure Guages of all kinds, Pressure Registers, Pressure and Vacuum Registers, Pressure Indicators (sizes 4 inch, 6 inch and 9 inch), King's Pressure and Vacuum Gauges, Dry and Wet Centre Seals, Dry and Wet Governors, Exhauster Governors, Photometers of all descriptions. Letheby's Sulphur and Ammonia Test Apparatus complete—also Testing and Chemical Apparatus of all kinds, and of the most perfect description, for all purposes relating to Gas.

GOODWIN'S IMPROVED LOWE'S JET PHOTOMETER.

Agents for Bray's Patent Gas Burners and Lanterns.

Special attention to repairs of Meters, and all apparatus connected with the business.
All work guaranteed first class in every particular, and orders filled promptly.

G. B. EDWARDS, Mang'r, New York.
E. H. B. TWINING, Mang'r, Chicago.
Represented by A. B. STANNARD.

D. McDONALD & CO.,

GAS METER MANUFACTURERS.

(Established 1854.)

51 Lancaster St., Albany, N. Y. 34 & 36 West Monroe St., Chicago, Ill.

STATION METERS, EXPERIMENTAL METERS, METER PROVERS, PRESSURE & VACUUM REGISTERS, PRESSURE GAUGES, ETC.

Also STAR GAS STOVES, RANGES, and HEATING STOVES.

We use only the very best materials, and employ the most skilled labor, and by our long experience (32 years) and personal supervision of every detail, we feel justified in assuring the public that our goods will give perfect satisfaction. Every Meter emanating from our establishment will bear the State Inspector's **BADGE**, and will be fully warranted by us. Our Annual and Calendar will be sent to Gas Companies upon application.

GAS ENGINES.

GAS ENGINES.

GAS ENGINES.

THE "OTTO" GAS ENGINE.

Guaranteed to Consume 25 to 75
Per Cent. LESS GAS than **ANY** OTHER GAS ENGINE
DOING THE SAME WORK.

TWIN ENGINES Impulse every revolution.
THE STEADIEST RUNNING GAS ENGINE YET MADE.

ENCINES AND PUMPS COMBINED,

For Hydraulic Elevators, Town Water Supply, or Railway Service.

Special Engines for Electric Light Work.

OVER 15,000
IN USE.

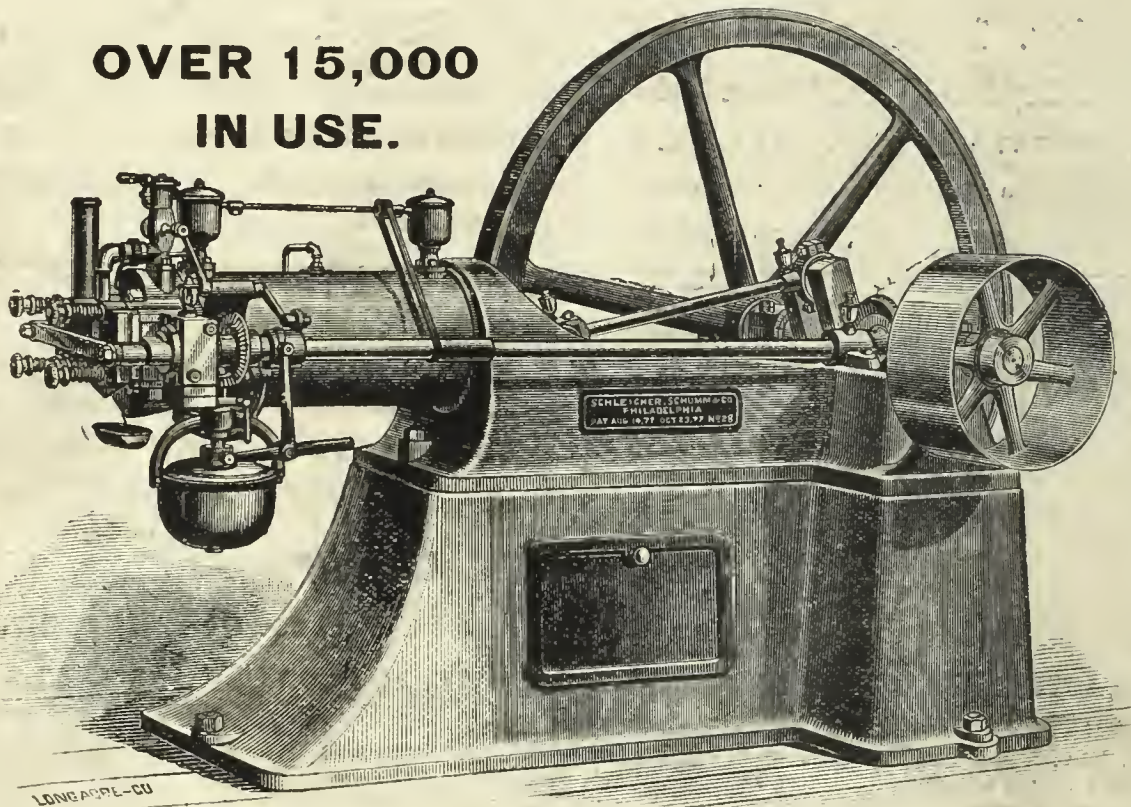

The Otto Gas Engine is now consuming, at a moderate computation, 2000 millions cubic feet of gas per year, nearly all of which is furnished during day time only.

**THE ONLY HIGHEST AWARD, ONLY GOLD MEDAL,
AT ELECTRICAL EXHIBITION, PARIS, 1881.**

MADE IN SIZES FROM 1 TO 25 HP. INDICATED.

FOR PARTICULARS, PRICES, ETC., APPLY TO

SCHLEICHER, SCHUMM & CO.,

Works:

N E. Cor. 33d & Walnut Sts., Phila., Pa.

Branch Office:

130 Washington Street, Chicago, Ill.

THE AMERICAN

GAS LIGHT JOURNAL

REDMAN & KENNY, N. Y.

PUBLISHING OFFICE No. 42 PINE STREET

DEVOTED TO THE INTERESTS OF ILLUMINATION, VENTILATION, WATER SUPPLY AND DISTRIBUTION, & GENERAL SCIENCE.

VOLUME XLVI.—No. 9. }
Whole No. 669.

NEW YORK, MONDAY, MAY 2, 1887.

{ \$3 PER ANNUM,
IN ADVANCE.

A. M. CALLENDER & Co., Proprietors. C. E. SANDERSON, Manager.
JOS. R. THOMAS, C.E., Editor. T. J. CUNNINGHAM, Asst. Editor.

ENTERED AT THE POST OFFICE AT NEW YORK, N. Y.
AS SECOND CLASS MATTER.

Published on the 2d and 16th of each month, at No. 42 Pine Street, N. Y.
Terms of Subscription, Including Postage.—For the United States and Canada, \$3 per annum. European countries, \$3.50 (15 shillings—18 francs). All payments to be made in advance. Single copies, 15 cents.
Remittances should be made either by post-office order, registered letter, or bank draft on New York, payable to the order of A. M. Callender & Co.
Correspondence.—Wishing to make this JOURNAL a gazette of intelligent discussion to those of our readers who may wish to gain or give information on the subjects to which its columns are devoted, correspondence is solicited for publication from all who make the study of those subjects a pleasure or a profession.
The American News Company, Nos. 39 and 41 Chambers street, New York, are agents for this JOURNAL. Newsdealers will send orders to them.

CONTENTS.

An Asterisk (*) denotes an illustrated article.

OFFICIAL NOTICE—	
Western Gas Association.....	277
EDITORIALS—	
Almost Ready for the St. Louis Meeting.....	278
Obituary—J. O. King.....	278
Suits for Damages.....	278
Removals.....	278
Third Annual Meeting of the Ohio Gas Light Association—Official Report—Continued from page 251.....	279
Tar as an Enricher, by E. W. Hamlin—Discussion—Report of Committee on Nominations—An Interjected Question—*Causes and Prevention of Stoppage in Burner Tips, by Eugene Printz—A Regenerative Furnace Adapted to a Small Gas Works, by Irvin Butterworth—Discussion—Second Day, Morning Session—Condensation and the Elimination of Tar, by T. A. Bates—Discussion.	
Is Lofty Guide Framing Necessary for Large Gasholders?.....	284
Standard Pipe and Pipe Threads.....	285
Special English Correspondence.....	286
Oil Gas in England—New Way of Utilizing Coke—Paris Gas—The Status of Gas Engineers—Honesty is the Best Policy—Novel Views Respecting Gasholder Guide Framing—Pushing the Use of Gas Cooking Stoves.	
ITEMS OF INTEREST FROM VARIOUS LOCALITIES.....	287
The Columbus (Ohio) Gas Company Proclaims the Dollar Rate—Cheaper Gas for Boston, Mass.—Annual Election, American Meter Company—An Item from Far-away Fargo—Public Lighting at Troy, N. Y.—A Siemens-Lungren Company for New York City—New Gas Company—Proposing to Start an Opposition Gas Company—Improvements at Montclair, N. J.—Annual Election, Rome, N. Y.—How it is Done at Brookline, Mass.—Tonawanda Appreciates the Situation—A Gas Works at Auction—Cheaper Gas for Athens, Ohio—Following in His Father's Footsteps—A Meter on Exhibition—Chartered—Jarvis Steam Plant for the Burlington (Vt.) Gas Company—Consolidated at Brattleboro, Vt.—The Cost of It—Hastings' Gas Rate—Ventura (Cal.) has Gas—Electric Light for Bismarck City, Dak. Ter.—Coke is Worth Something in the Lone Star State—Street Lighting at Newburgh, N. Y.—Moribund—Sorry to Know that He Goes so far from Us—Incorporated—Col. Benson's European Studies.	
CORRESPONDENCE—	
Public Lighting in Brooklyn, N. Y.....	289
The Market for Gas Securities.....	290

[OFFICIAL NOTICE.]

Western Gas Association.

SECRETARY'S OFFICE,
QUINCY, ILLS., April 25th, 1887. }

The Tenth Annual Meeting of the Western Gas Association will be held at St. Louis, Mo., on the 11th, 12th and 13th days of May. The rates at the Southern, fixed upon as the headquarters of the Association, will be \$3 and \$3.50 per day.

The business sessions will be conducted in the lodge room of the Elks' Club, corner of Sixth and Walnut streets, one block from the hotel. The convention will be called to order at ten o'clock, on the morning of Wednesday, May 11th, by President John Fullagar.

Your Secretary is reluctantly compelled to forego the pleasure, which he had both hoped and expected to enjoy, of announcing for our Association's entertainment in this the last issue of the JOURNAL which will reach our members before the date of the meeting, the anticipated presentation of a generous number of titled papers. All that I am able to state in this connection is that several essays have been promised, but as their authors have failed to notify me of the titles of their contributions in time for publication, I cannot make the desired announcement.

I do not know that any apology on the part of the Secretary for this dissatisfactory state of affairs is necessary, or expected. I certainly have tried hard enough to induce our members to put forward their best efforts for the good of the Association, but the success realized seems at present entirely disproportionate to the labor expended. The old wheel horses who have stood by us so faithfully in the past are disinclined to continue their work with increasing regularity, thinking, no doubt (and thinking rightly), that it is quite time for others to don the harness. If we had an Association composed exclusively of Somervilles, McMillins, Kings, Ramsdells, Hydes, Chollars, Howards, Gimpers, and possibly a few, a very few, others, the work of a Secretary would be immeasurably lightened, so far as the securing of literary contributions is concerned; but it is too much to expect these members to step to the front at each succeeding meeting, when we have so many others abundantly qualified for the task, if they would only take the trouble to perform the duty.

For the above reason, if for no others, it would seem as though the time had arrived when it has become necessary to adopt some such plan as was chosen by the Ohio Gas Light Association, and which, in practice, has been attended with such satisfactory results.

Too much praise cannot be bestowed upon our Local Committee of Arrangements—Messrs. J. D. Thompson, T. G. Russell, and Jas. Green—for the commendable zeal and energy that they have displayed in providing for the comfort and pleasure of those who will be in attendance at our St. Louis meeting. Your Secretary risks nothing in saying that the social features of the approaching reunion will be of a most pleasant character, as all whose good fortune it may be to participate therein will be quite willing to testify.

In closing, allow me, in behalf of the Western Gas Association, to extend to the members of all kindred societies a most hearty invitation to be present, assuring them that we will all, each and every one, endeavor

Messrs. Bartlett, Hayward & Co., of Baltimore, Md., now control all right in the Wilkinson process for the manufacture of water gas. Their announcement in this regard will appear in our next number.

to make them feel that their welcome is as warm as we trust that they may find their visit pleasant.

A. W. LITTLETON, Sec'y.

ALMOST READY FOR THE ST. LOUIS MEETING.

The tenth birthday of the Western Gas Association, if one may judge of what is to be from the rumors which reach us by way of St. Louis in regard to the outlook, is certain to be celebrated with that heartiness which usually accompanies a sound and vigorous growth; but, nevertheless, the advices from Quincy, Ill., in regard to the papers that are catalogued, are not so reassuring. However, if there be some doubt in that direction, even the most chronic and erratic fault-finders must at once concede that Secretary Littleton has performed his whole duty in the premises. The genial and persistent member from Quincy has left no stone overturned in the performance of his official duties, and we take it that his pointed reference to what would be the case were the Association composed exclusively of Somervilles, McMillins, Ramsdells, and others of similar kind, will be appreciated at a glance. These members have borne the burden for quite a while, and need not offer any explanation for their present silence. However, since the unexpected is pretty often encountered, perhaps many of the hitherto silent members of the Association are preparing a surprise for their fellows, and in the hope that such is the case, and that Secretary Littleton's really arduous work will be compensated for by a rousing development of "the unexpected," we must await the result at St. Louis. Perhaps the present paucity of the paper list will work advantageously in that a greater margin of time can be allotted to the discussion of subjects which, like the ghost of ancient renown, will not down. Prominent among the moot points are—legislation affecting the business of the gas maker, and the combined supply of gas and electricity. During the present session of the Illinois Legislature a plan for placing the gas business of that State under control of a State Commission was proposed by, we believe, Senator Cable; and while we are not aware as to what, if any, final legislative action was taken in this particular case, it nevertheless instances the drift of sentiment, and points to the fact that, sooner or later, the State intends to figure more prominently than it has in the past—many will say that that is an impossibility—in its dealings with the gas suppliers. New York seems to be anxious to go on with the work—two or three commission measures are now before the attention of the Solons (?) of the Empire State; the Senate of the United States wishes to dictate to the Gas Company operating in the District of Columbia; the session of the New Jersey Legislature (fortunately it has ended its labor for the year) witnessed an attempt to interfere in gas matters. And so it goes. The agitation on this question of control is not confined to any one State; and we therefore hold that, if interference is to come, the gas men ought to get themselves in readiness, and so be prepared to oppose that which is unjust, or to uphold the contrary. The other subject—combined gas and electric light supply—is also one of the "burning questions" of the day; and since it appears that the effects of electric competition have been perhaps more severely felt by Western gas makers than by their brethren of the East, the members of the Western Association seemingly ought to be thoroughly qualified to speak by the book in formulating a verdict on the proposition.

In respect of the social features of the gathering, neither labor, time nor money seem to have been stinted by the local committee in their preparations for the entertainment of the Association and its guests. Mention of the latter spurs us on to say that many members of the Eastern fraternity have signified their intention of paying their respects in person to their Western brethren—even though the Interstate bill is in full feather. We have received an intimation that the entertainment programme provides for a banquet at the Southern Hotel, a lunch at the Club House of the St. Louis Jockey Club, a steamboat excursion, and many minor items that go to make a most imposing total. Indeed, it is but necessary to remember the characteristics of the gentlemen who compose the committee in order that the completeness of their preparations can be vouched for.

One cloud, however, must rest over what otherwise would be a meeting fraught with unalloyed pleasure, and that leaven of regret springs from the knowledge that the Association must, in accordance with the Divine mandate that called away from earth and his fellows the spirit of the late Mr. J. O. King, of Jacksonville, Ills., mourn deeply for one who was justly entitled to the name of founder of the Western Association. His labors, however, are keenly appreciated by those who have so often listened and gained by his counseling; and their regret, although deeply and firmly held, will be tempered in the knowledge that fullness of years and merited honor were accorded him; and of anyone who resigns the burden of life, what can be said that offers greater consolation to those who remain?

OBITUARY—J. O. KING.

Death has dealt most harshly with the fraternity so far in the present year, and the latest stroke of the destroyer obliges us to record the death of Mr. J. O. King, Supt. of the Jacksonville Gas Light Company, and the first President of the Western Gas Association, whose decease occurred on the morning of April 16. Deceased had suffered for some months from the effects of an attack of inflammation of the bowels, and those about him were gradually prepared for the final sad ending.

Mr. King was born, in Enfield, Conn., on May 18, 1814, remaining in his native town until 1837, when he first visited Jacksonville, to which place he was called by reason of certain business interests, and wherein the balance of his busy and successful life was spent. In 1840 he returned temporarily to the East, the objective point of his visit being Amherst, Mass., where he was united in marriage to Miss Sarah L. Dwight, shortly after which ceremony the youthful couple journeyed to Jacksonville, there to live a life of unbroken harmony that only ceased with the death of Mrs. King, in May, 1882.

Mr. King had, in the interim of 1837–57, been interested in various local business enterprises; in fact he was most intimately connected with the prosperity of his adopted city, and aided it not a little by willing expenditure of brain and muscle. In 1857 the local gas plant, which had been built by speculators, was in wretched condition, and the residents clamored loudly for a change in the policy of the Company. Mr. King and associates thereupon determined to secure control, which was speedily accomplished, and the work of rejuvenation was commenced. This was no slight matter—for many and startling changes have been wrought in Illinois within the past 30 years—at that time, but Mr. King, who assumed the superintendency, being gifted with rare executive ability, coupled with a studious mind, soon evolved order out of chaos, and placed the Company's affairs on a sound footing. He remained the nominal Superintendent up to the hour of his death, although, in later years, the brunt of the work has been borne by his son, Mr. E. J. King, who is also well known to the fraternity of this country. Like all men who are disposed to look ahead in providing for the future of the towns in which they live, Mr. King was rather savagely attacked by the opponents of a plan proposed by him for securing a proper system of water supply for Jacksonville. Almost single-handed he contended for the project, and was finally successful; further, the pleasure of living to see the day when those who opposed him on that question later on acclaimed him a public benefactor, was his. The Insane Hospital and the Asylum for the Blind were located at Jacksonville largely by his efforts, and in every local charity trace can be had of his name. He was many times elected by his fellow townsmen to fill places of public trust, the last position of that nature being held by him in 1874, when he occupied the Mayoralty chair. Mr. King was an ardent abolitionist, and it is matter of record that, several years before the war, the freedom party, of Morgan county, Ills., was organized by Mr. King and six kindred spirits. The pages of the JOURNAL, Vol. XXIX., will reveal the share borne by deceased in the formation of the Western Gas Association. He was actually its founder, for the initial circular call emanated from him, and he was also the first formally elected President of that organization. In its progress he was ever deeply interested, and the debt which it owes him can best be repaid by remembering his advice and acting in consonance therewith. Of his immediate family two sons, Wm. M., of this city, and E. J., of Jacksonville, also two daughters, Mrs. E. Dwight, of New York, and Miss Mary, of Jacksonville, survive. In conclusion, we think the following extract, from an obituary notice of deceased, published in the Jacksonville *Herald*, will best tell the story of how he was regarded by his fellow townsmen:

"He was ever a genial companion, and foremost in every good word and work for the public good. He was a model husband and father, and was ever ready to give material aid to a young man who was striving to do his best. His kindness to us when struggling in early life will never be forgotten." Very simple words; but they bear most eloquent testimony.

SUITS FOR DAMAGES.—On April 16, suits (thirteen in number) were instituted against the Troy Fuel Gas Company, on behalf of those who suffered on account of the January disaster, hitherto reported in the JOURNAL.

REMOVALS.—The offices of the Bartlett Street Lamp Manufacturing Company are now to be found at Nos. 40 and 42 College Place, this city. Mr. M. J. Drummond, dealer in cast iron gas and water pipe, etc., will hereafter be found in handsome apartments in that wonder of office structures, the Equitable Building, Broadway.

[OFFICIAL REPORT—Continued from page 251.]

Third Annual Meeting of the Ohio Gas Light Association.

HELD AT THE BECKEL HOUSE, DAYTON, OHIO, MARCH 16 AND 17, 1887.

FIRST DAY—EVENING SESSION.

Mr. E. W. Hamlin, of Wilmington, read the following paper, on

TAR AS AN ENRICHER.

Mr. President, and Members of the Association:—Only a few years since the tar made at gas works—at least the small ones—was considered a nuisance, and how to get rid of it was the query that occupied the mind of the gas man. If by chance, or otherwise, any of it found its way into a stream of water, the authorities would “go for him” with the combined dignity of themselves and the law, and compel its abatement. Gradually its latent wealth has been uncovered, and it has already taken so firm a hold in the commercial *utilities* of the world that one would hardly recognize it as the same material known as a nuisance. While it is true that only the large works can avail themselves of all the properties contained in tar, and by that means be able to sell their gas at a less price than the small works, still I believe there is a profit for us with benches of threes other than the local demand for decorating fence posts, destroying potato bugs, or converting into coke, by burning the tar and selling the coke. It is my purpose in this paper to tell you of an apparatus I have constructed for enriching gas with tar, extracting naphthaline from gas, and the results obtained from its use.

The machine is very simple in its construction, and can be put into a works at a small cost; and if at any time you should conclude to abandon it as an enricher (which time will never happen if it gives the same satisfaction we get), all you have to do is to unscrew the stopper, and the gas will pass on the same as before the enricher was put in.

The process is simply passing gas with steam (or separately) through hot tar. To accomplish it I took a galvanized iron boiler, of the kind the plumber puts in your kitchen to heat water, and through the inlet end I run a wrought iron pipe, the size of the main, to within 12 inches of the outlet end, allowing it to project from the inlet end far enough to make a lead joint with the main, previously cut and taken out to give room for the enricher. With threads cut on the wrought iron pipe, and with lock-nuts, it was fastened to the inlet end of the boiler, and a tight joint secured. At the outlet end it is held in position by a stirrup, so that it stands its entire length about six inches from the bottom of the boiler. On the lower side of this wrought iron pipe, holes were drilled for one-inch pipes, sufficient for the capacity of the main pipe and 12½ per cent. to spare. These one-inch pipes extend to within two inches of the bottom of the boiler. Near the top of the outlet end of the boiler is a short wrought iron pipe, same size of the main, secured to the end of the boiler with lock-nuts, and the main in the works by a lead joint. This is the outlet pipe for the passage of the gas. Below this outlet pipe, and immediately opposite the wrought iron pipe in the boiler, an iron rod runs into the latter. It has a plug, with guides, on the inside end, and so arranged, with threads, on the rod and the end of the boiler that by simply turning the rod the plug is forced into the end of the main pipe in the boiler, thus compelling the gas and steam to pass through the tar. By unscrewing the rod the plug is removed from the pipe, permitting the gas to pass with the same freedom as if the enricher was not there. A revolving gate valve would be more convenient, as a slight turn would immediately stop or permit the flow of the gas and steam. In the bottom of the boiler, at the outlet end, is the tar seal, also the tar outlet, so arranged that by simply turning this outlet pipe the seal can be raised or lowered.

The machine is located in the cellar between the exhauster (steam-jet) and the washer. The tar can enter directly from the hydraulic main seal by a pipe (with proper seal) in the enricher, then drop into the galvanized iron boiler through hugging the hot main, and run to the inlet end of the enricher, by which means it becomes heated; or through the main (with seal) and become heated and carried along by the gas and steam as they pass on their way to the enricher. It is there subjected to the action of the hot gas and steam, and passes the entire length of the enricher before it reaches its outlet. This agitation of the hot tar by the gas and steam not only hastens the dissolution of the hydrocarbons, but prevents “pitching.”

At first we tried a 2½-inch seal in the enricher, but found we had enough pressure to carry more. The greater the seal the more tar comes in contact with the gas and steam, and the more illuminating oils are liberated to be absorbed by the gas. I have made provision for a steam pipe to run through the tar for the purpose of heating and scouring it,

and to act as an exhauster for the enricher in case there should not be sufficient pressure to force the gas through the works; but, thus far, we have not had occasion to use it. There are hand holes for the easy adjustment and inspection of the machine. I hope this description is sufficiently plain to enable you to get the idea. Let us now pass to the results.

By a careful analysis of the tar before it entered the enricher and after it had passed through it, it was found that 32.7 per cent. of the hydrocarbons had been extracted from it, and carried off with the gas—not only increasing the candle power, but the yield as well. I will add that where hot air was substituted for steam the results were not as favorable.

So much for the testimony of the laboratory. We will now go to the street main. We use the jet photometer made by the American Meter Company. From a series of careful consecutive observations, made before the enricher was started, and the same number after, we found the candle power of the gas was increased 11.33 per cent. This was after the gas passed from the holder. Nor is that the limit, for I feel safe in saying that this process will extract more of the hydrocarbons and add to the candle power and yield.

I regret I am not able to give you, from analysis, the effect this process has on naphthaline; but we know about its easy solution in hot water, and for that reason does not the steam and hot ammonia water assist in removing it? It does; and as evidence of that fact I will state that, after we had commenced the use of iron sponge, we found traces of naphthaline in our purifiers, also in our meters—we do our own meter repairing; but since this process was adapted it has disappeared. We have not noticed any deterioration in the fuel properties of the tar.

In fine, this gain has been accomplished without one cent. of extra expense, save the cost of the machine. It requires no attention. There are no choked stand-pipes to be burned out, or bearings that require oil. On the contrary, it takes care of itself, and the sound it sends forth when at its best, coupled with the satisfaction it gives, is so melodious to the ears of the men about the works that they call it “their organ.”

Discussion.

Mr. Coverdale—About what would be the cost of getting up such a machine as that?

Mr. Hamlin—I think the one described cost more than another would, for the reason that the workmen who built it had to be instructed, and a part of it was not done correctly. I think it cost something like \$60; at least that is the cost for a works of the size of ours. You can make your own calculation as to what it would cost for a larger plant. The analysis of the tar was made shortly after we started. I have reason to think that to-day we take more of the hydrocarbons out than we did then. I will state that the candle power I have given is a record of 50 consecutive observations taken before and after the enricher was started. The reason I did not take a greater number of observations was because, prior to starting with it, I did not have a record of candle power that I could rely on. At that time we were in the habit of taking the candle power only at intervals; but when we contemplated starting the enricher we took it every day.

Mr. Printz—I would like to ask Mr. Hamlin what yield he gets from his coal, and what his candle power was before he introduced this machine.

Mr. Hammond—I cannot be accurate as to our yield last year.

Mr. Coverdale—What would the coal yield supposing you now dispensed with the enricher apparatus?

Mr. Hamlin—The yield we obtained the year before starting the enricher device was 4.65. I cannot be accurate as to last year, because our station meter was not correct. The water line was not kept at proper level. It is the same with our unaccounted-for gas. I cannot speak correctly as to that. In the year 1885 the percentage was 10.83, and our books show that in 1886 our unaccounted-for gas amounted to between six and seven per cent., which latter I know to be incorrect. The average of our candle power before putting in that enricher device was 17.564; after we put the enricher in it was 19.554.

Mr. Allison—How long have you been using that apparatus?

Mr. Hamlin—We put it in early last fall, and have been using it almost constantly since. I wish to add that I have not yet patented this device, but intend to apply for a patent.

On motion of Mr. Coverdale a vote of thanks was passed to Mr. Hamlin.

REPORT OF COMMITTEE ON NOMINATIONS.

Mr. Huntington—The Committee instructs me to report the following names for officers of this Association during the coming year. Under your by-laws this Committee is required to present two nominees for each office.

President—Eugene Printz and Thomas Wood.

Vice-President—Joseph Gwynne and John Fullager.

Secretary—Irvin Butterworth and Charles M. Converse.

Treasurer—E. W. Hamlin and Edward C. Gwyn.

The President announced that the election would take place when all the papers had been read and discussed.

AN INTERJECTED QUESTION.

Mr. Converse—One of my consumers wanted me to bring this question before the Association: "Can coal gas be used with any degree of economy, as compared with anthracite coal at \$8 per ton, in generating steam to heat a building of 10 or 12 rooms—labor and items of convenience also to be considered—the price of gas being at \$2 per thousand?" Perhaps the question had better be put: "At what price would gas have to be sold to compete with coal at this price?"

The President—I will say, in answer to the question, that wherever coal is used constantly (where the fire is kept up the whole 24 hours) it would not be possible for gas to compete with anthracite coal at the prices given. It would not be possible even were the gas at \$1 and the anthracite coal at \$10. In fact, the difference between the heating powers of the two is so enormously great that I do not want to state it in the presence of the reporters.

Mr. Eugene Printz, of Zanesville, now read his paper on

CAUSES AND PREVENTION OF STOPPAGE IN BURNER TIPS.

The stoppages in burner tips are due to causes both mechanical and chemical. Those which we would term mechanical are produced by fine particles of rust, or any other dirt that may happen to be in the pipe. The particles may be loosened by a jar, and then carried by the flow of gas to the tip, where, should the material so carried be larger than the cross-opening in the tip, it is arrested, and finally, by its accumulation, creates a complete shut off of the gas. Stoppages of this kind are easily prevented by blowing or clearing out the pipes thoroughly.

Again, we have cases where the tarry vapors are carried mechanically in the gas past all the gas works machinery, and are found, in the shape of a gummy soot-substance, at the burner tips. This certainly should not be, and is due to an imperfect apparatus for the separation of the tarry matter.

Mechanical causes are easily accounted for, and, we might say in many cases, are as easily remedied or prevented; but those of a chemical nature are often very difficult to name. And then again, having ascertained the cause, it is more difficult to relieve or prevent. In fact, as was stated at the last meeting of the New England Association of Gas Engineers, by Mr. M. S. Greenough, of Boston, Mass., who, in speaking* of the stoppage of burners, said he had, as a remedy, substituted one enriching material for another, thinking the first had been the cause of the stoppage, but "the substitution did not seem to have any effect on the burner difficulty," and "that the trouble afterwards disappeared—for the same unexplained reason that a great many other things happen;" or, as we might infer, things did happen for which we failed many times to get a reason.

Having had quite a number of complaints of the stoppage of burners during the past two winters, and knowing at the same time that an excess of ammonia was being passed over, also noticing, as a general rule, the complaints came mostly from persons using clay, or more commonly termed, lava tips, and that very seldom did we hear anything from persons using iron or metal tips, the first thought which occurred to me was that a combination of the ammonia with the copper of the fixtures, forming the blue dust found in them, which being carried by the gas to the clay tip was decomposed, the ammonia liberated, and the copper deposited as cupric oxide—black oxide of copper—which is prepared by heating fragments of copper to low redness on a piece of earthenware. I should have said the complaints were mostly about burners used as night lights—that is, those burning at half-head or less, thus producing the low temperature which is conducive to the formation of cupric oxide from copper. The deposit when examined under the glass was composed of spars (large and small) of one general prismatic form, but failed to give any trace of metal when submitted to an analysis, thus proving the ammonia-copper combination theory false. The deposit proved to be carbon, not of a soft soot nature, but quite firm and hard.

The question then arose, "What produced the carbon in this form and at that particular point?" Knowing that during the winter months we were compelled to send our gas through the purifiers too quickly to allow the proper time for the chemical combinations and decompositions to take place, and that the bisulphide of carbon impurity did pass over, and also learning that this compound could be decomposed from gas by being

passed over clay heated to between 400° and 600° of temperature, the sulphur combining with hydrogen to form sulphuretted hydrogen, and the carbon deposited on the clay, and this being so much like in nature to the cause which would probably lead to our trouble, we thought it advisable to experiment in that direction in the following manner:

First, to pass the gas through several solutions of the acetate of lead, to make sure of the removal of all the sulphide of hydrogen possible; then through a glass tube partially filled with pellets of dried clay—the tube in the meantime to be heated at a low temperature; finally, the gas was passed through a single solution of the lead, to see if the decomposition and recombination did take place, with the following result:

Gas which, previous to its entrance to the tube was entirely free from sulphide of hydrogen, did afterward contain a quantity sufficient, in very short time, to completely saturate the solution, thus proving that sulphur was separated. We also found that a burner consuming the gas previous to the elimination of the bisulphide, or that which was not passed through the tube, did, in a very short time, show a strong evidence of the carbon deposit; whilst another burner, of the same make and size, consuming the decomposed gas gave no sign at all of stoppage.

As stated before, the complaints came mostly from persons using the low or night lights. On those burners the crystals were deposited, on either side of the slot, on the tip in a fringe-like mass, as per the sample we have here for your inspection. The explanation of this, we would

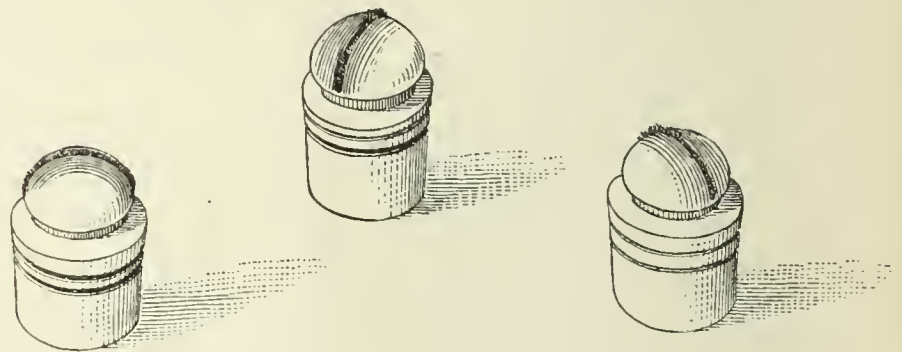

think to be that, the light being down low, the requisite temperature of the clay tip for the decomposition of the bisulphide was not reached until the gas was just passing from the opening, and then the deposit was made on the outside. We did have some complaint from burners that were expected to be burned at a full head, but think the bisulphide theory will hold good, and can be accounted for in this manner.

When the lights are burning full the necessary temperature to decompose the gas is raised further down, or inside the tip, and there the carbon crystals are formed and deposited—then may be broken or detached and carried on by the flow of gas to the slot. Being very small, should they enter the slot lengthwise they pass on and are consumed in the flame; but on the other hand, should they strike crosswise they are apt to remain, causing a division in the jet of light, and finally, by their increase in number, require the use of a burner cleaner, or a complete stoppage of the gas is the result.

We have here, then, not only a cause for the stoppage of the burners, but a reason for the sulphur fumes that are complained of at times. The carbon of the bisulphide being deposited, the sulphur unites with hydrogen to pass through or from the burners as the sulphide of hydrogen.

Looking at the matter in this light, is it not probable that many of us do not appreciate the importance of the bisulphide of carbon as an impurity; and should we not be better prepared for its elimination? To be sure, we expect the ammonia in the washers, as sulphide of ammonium, or the lime in purifiers, as the sulphide of calcium, to perform this duty; but as these do often fail, and as a precaution, then, would it not be well for us in some manner to take out or decompose the bisulphide before the gas enters the lime or oxide of iron purifiers, giving them only the sulphide of hydrogen to deal with? As a suggestion, let the gas be passed through an iron retort filled with a loose clay material, heated to about 500° temperature by utilizing the waste heat from the furnaces. This should be done after all the tar has been extracted, otherwise the clay material would soon be choked. It may be possible that the watery vapors would be decomposed; but would this be a disadvantage? Is it not likely, in this case, there would be a recombination of the hydrogen with carbon and sulphur dropped as free sulphur? or possibly a monoxide of carbon would form, which, while not a light producer of itself, might be useful as a heat producer, and thus have a tendency to increase the illuminating power of the gas?

This paper was not discussed. On motion of Mr. Alexander, a vote of thanks was tendered to Mr. Printz.

* See JOURNAL, March 2, p. 442.

Mr. Irvin Butterworth, of Columbus, read a paper entitled—

A REGENERATIVE FURNACE ADAPTED TO A SMALL WORKS.

It has occurred to me that many managers of small works would be glad to convert their old-style furnaces into furnaces built on the regenerative plan if they were aware that it can be easily and profitably done. The furnace of which I shall attempt a brief description is one which replaced an old-style furnace, and is now in operation at Columbus. It is, therefore, adapted to a larger as well as to a small works, and I have designated it as being adapted to a small works simply because it does not require a retort house with a cellar, but which can be easily introduced into any gas works, however small, with comparatively little expenditure of time or money, and with an increase of 100 per cent. in efficiency over the old style of direct firing furnace.

It does require, however, a shallow pit in the retort house floor in front of the bench, about 2 feet deep, and extending back 6 feet from the furnace, wide enough for a man to work in, and covered with heavy sheet iron doors, so hinged as to be easily opened and thrown back for entrance into the pit, for the purpose of clinkering the furnace and cleaning out the ashpan.

It also requires a deep excavation for the furnace setting—say, to a depth of 3 feet below the retort house floor, in order that the furnace itself may have room for the deep bed of hot coke, and the space about it for the intermingling and combustion of the gases.

The walls that support the arches should be built of firebrick to the very bottom as an attempt at Columbus to utilize the old common brick walls that had served as foundations for the arches, resulted very disastrously.

The furnace settings must, of course, be provided with the secondary air flues essential to the regenerative principle; and, unless the waste heats are passed under the ashpan, there must be a pipe for supplying steam under the grate bars.

The furnace itself will be 5 ft. 3 in. long, and about 3 ft. 3 in. deep—that is, from the top of the grate bars to the secondary air ports; or, it will be 5 feet deep from the bottom of the retorts to the bottom of the ashpan, and will be 20 in. wide in the middle, and 12 in. at the top and bottom. An open space of 7½ in. between the ashpan and grate bars is provided for access into the ashpan for the purpose of cleaning it out, and it also admits air for draught and primary combustion. An excess of air is prevented from entering so large an opening by the sheet iron doors that cover the pit, which are made to fit so closely in their places as to partially exclude the air. The openings for the admission of air for secondary combustion are placed at about the height of the grate bars, and are, therefore, below the iron doors that constitute the floor in front of the bench. This position renders the slides that regulate the quantity of air admitted least liable to be accidentally moved in taking care of the coke that is drawn from the retorts. The air for secondary combustion is made to pass backward and forward in the setting through 2-inch pipes, laid one above the other about 5 inches apart, and extending to the very bottom of the setting. It then passes into a reservoir or "equalizing chamber," 9 in. by 21 in., and 18 in. deep, built immediately back of the furnace, into which it is next conducted through the necessary flues and ports.

The products of combustion, after descending through the openings near the front of the furnace between the bottom retort and the arch, fill the large waste heat chambers at the sides of the furnace, and find an exit through a flue in the rear of the setting.

The furnace is charged with coke drawn directly from the top retorts into the furnace by means of a movable chute, through a round door, 12 in. in diameter, situated between, and a little above, the center of the two bottom retorts.

It will be seen that this furnace is simply a modification of the regenerative furnace in use in works whose retort houses were provided with cellars; but since it is difficult of description, and needs some further illustration than is possible within the limits of this paper, I have constructed a sort of model of the furnace out of wooden blocks ("out of my own head," as a certain amateur carpenter is said to have boasted, "and have wood enough left for another!") so made that it can be taken apart and its construction examined. I hope the members who are interested will examine this model and ask any questions about the furnace that it does not answer. I have also here a diagram of the front wall of the furnace.

With this furnace we have readily carbonized 300 pounds of Youghiogheny coal to the retort every four hours, the retorts being 14 × 22, and 9 ft. long. The old-style furnace which this replaced would, under favorable conditions, carbonize 200 pounds.

This furnace, as I have endeavored to describe it, is simple in its con-

struction and easily managed. It does almost double the work of an old-style furnace; and, as I have said, can be readily and economically substituted for it in any gas works, however small.

But our best results at Columbus are derived from a furnace built precisely like the one I have described, with the addition that the products of combustion are made to pass under the ashpan and through an underground flue to a high smoke-stack. The model will show how the setting is constructed for passing the waste heats under the ashpan. To do this a deeper excavation for the setting is, of course, necessary. A small stream of water is kept constantly trickling into the ashpan, and the waste heats, passing under it, produce sufficient evaporation to furnish steam for the generation of CO, and for softening the clinker, although a steam pipe is also provided for use in case of necessity. By actual measurement, each of these furnaces was found to evaporate 602.7 pounds of water daily, or one pound for every 3.8 pounds of coke drawn into the furnace.

With this furnace we have thoroughly carbonized 1,900 pounds in six retorts, 14 in. × 22 in., and 9 ft. long, every four hours; and it has maintained sufficient heat to do this on much less than one-fourth of the coke produced. Indeed, we had considerable trouble to keep our heats from getting too high.

I may add, in conclusion, as a matter of interest, that, before reaching the smoke-stack, our waste heats are made to pass through a boiler, and by that means help maintain steam for the use of the works.

Discussion.

Mr. Hamlin—I have been greatly interested in that paper. We have been trying for some time to see if we could not improve the settings of our furnaces. The only improvement made thus far was by going down about 2½ feet further than we had gone, and utilizing that additional depth for coke, thus increasing the capacity of our fires. We intend to put in a new bench this year, and what we want to do is to put in the best one we can get. From the description Mr. Butterworth gives of this Columbus bench, I think that is what we want, provided we can get that bench in on 2½ feet below the floor.

The President—That is a plenty.

Mr. Hamlin—What would be the additional cost of that bench over a bench set in the old style, without disturbing the floor.

Mr. Butterworth—I cannot answer Mr. Hamlin's question, for the benches were built prior to my arrival at Columbus, and so I cannot speak as to their cost.

The President—I will answer the question. The tearing out and putting in the first time would probably add an additional cost, for labor and material, of \$150. After that there would be no additional expense to replace it.

Mr. Hamlin—Did you have your own retort setter to do it?

The President—Yes.

Mr. Hamlin—Are his services open to the public?

The President—No, sir; we have two, however, and we can lend you one of them. We sometimes lend one. I think that the owners of any works would be justified in going to the expense of remodeling their furnaces. I would expect, from the plan carried out by Mr. Hamlin of heaping his coke, without making any provision for the secondary combustion, that, all other things being equal, and there being no more care taken in firing, he would simply increase the quantity of coke used, without increasing his heat. Possibly he might burn more coke and get less heat. In other words, with your higher heat you burn, directly, the carbonic oxide, and get as good results as could be got from that quantity of coke burned in that way. It was burning the coke entirely up—burning the gases, gasifying them as highly as can be done; but if you deepen your floor, and make no provision for the secondary combustion, then the carbonic oxide formed at the bottom of the furnace is dissociated, and as no secondary air is admitted above the coke, it would escape unconsumed, so that you would really get less heat out of the same quantity of coke.

Mr. Hamlin—There are two advantages which we thought we derived from the plan. One was that we thought we got better results—we were able to keep our heats up better; the other was that we did not have to fire up so often.

Mr. Butterworth—It strikes me that it would not cost a great deal more in time or money to arrange the secondary air flues. After he had once lowered the furnace it would be a very much easier matter to construct the secondary air flues.

The President—If you have already gone about 2½ feet below the ordinary depth you can put in your secondary air flues and make that furnace with an additional cost of \$10. That is, when you come to reset your retorts again.

Mr. Bierce—Can this furnace be placed on an old setting, or is it necessary to make a new setting for it?

The President—It cannot be placed on old settings. It can be placed on old arches, but not on old settings.

On motion of Mr. Padan a vote of thanks was tendered to Mr. Butterworth for his paper:

The Association then adjourned to reassemble on Thursday, March 17, at 9 A.M.

SECOND DAY—MORNING SESSION.

The Association met at the hour appointed. Mr. T. A. Bates, of Circleville, read the following paper on

CONDENSATION AND THE ELIMINATION OF TAR.

The subject of the paper assigned me by the Executive Committee is of such importance, and capable of developing such knowledge of chemistry and the subtle components of gas in its various stages, that they should have chosen one better qualified than I to handle it; but, in obedience to orders, I will cheerfully add my mite of information.

The distillation of bituminous coal in retorts heated to an intensity of 2,100° to 2,600° F. produces dense vapor or smoke, varying in color from very dark slate to dark yellow, according to the period of its distillation. This dense, offensive and unsightly vapor becomes, after the process of condensing, scrubbing, washing, and purifying, the invisible (but, unconsumed, still offensive) gas of commerce, which has long since ceased to be a luxury, being now one of the most necessary, at the same time least appreciated, articles of manufacture.

The first process to which crude gas is subjected is termed "condensation"—the general acceptance of the term being a reduction of its temperature so as to facilitate the deposition of the useless and objectionable matters held in suspension by the gas at this stage, and which would prove detrimental, not only to the further process of purification but leave the evil effect of their presence on all the appliances required to carry the gas to the point of combustion. Now, while it is true that condensation is a great aid to purification, I think the assertion, "That, if thorough, it is half of the purification," is too broad and should be modified. The components of crude gas as it leaves the retorts, and as we should deliver it to our consumers, are either known to you all or are obtainable in any work on the "Chemistry of Coal Gas." With a knowledge of these before us, it does not require much chemical information to prove that *too rapid condensation* will rob the gas of constituents it should retain. While we are all fully alive to the dangers of too rapid condensation, I am not aware of the existence of any table setting forth the temperatures to be observed at the various stages in the passage of gas from retort to purifier. If such exists I have failed to see it. That one could be formulated, the arbitrary observance of which would meet the strict requirement of *all sizes* of works, I very much doubt. It is very evident to my mind, however, that such a rule would be of great benefit to many of our profession; and some of our more scientific brethren should give us one.

A brief notice of the methods adopted for the accomplishment of the necessary condensation of gas may now be in order. As a preliminary, we find in some works a continuation of the take-off pipe from the hydraulic main to as great an extent as possible, giving a *very slight* inclination to the run, the object being to keep the gas as long as possible in contact with the tarry matter so rapidly deposited after leaving the hydraulic main, thus enabling the gas to *take up* some of the hydrocarbons contained in the tar over which the gas passes. I have never been able to convince myself that this resulted in much good; the tar necessarily occupies but little space in the total area of the pipe, so the gas cannot be in contact with it, merely passing over. If rich hydrocarbons *are already precipitated*, and form part of the tarry compound, there seems to me to be nothing in the flow of this gas along the bottom of the pipe (always cooler than the tar) that will so volatilize these compounds as to cause them to rise and mingle again with the passing gas. The result aimed at in the adoption of this method could, I think, be better accomplished by *not allowing these very essential elements to leave the gas*; and as the rapid cooling of the gas on leaving the hydraulic main is the cause of much of this deposit, would it not be better to interpose a vessel near the hydraulic, having as much internal surface as possible, consistent with free working? The temperature in such vessel can be kept such as to preclude the throwing down of the lighter oils, and allowing such chemical changes to take place that shall *fix* a portion, at least, in the gas; while the contact of the gas with the material chosen to obstruct the flow, and give additional surface, will break up the minute globules that, in a film of tar, contain rich illuminants. These, being released, will be taken up by the passing gas, to its marked enrichment.

If the make of gas were such as to pass the gas from the hydraulic main to this vessel, at a temperature of 150° to 170° F., very good; if not, a steam coil could be introduced that would enable you to regulate the temperature. I would not stint this vessel in size, it being desirable to have the gas pass as slowly as possible through the material composing the filling. I am aware that the above-mentioned temperature is much below the boiling point of all but one of the substances contained in gas tar, many of which are valuable illuminants. We have such eminent authority as "Bowditch" for the statement, "That gas will carry forward to point of combustion hydrocarbon vapors whose boiling point is *far above* the temperature of the gas." I will say, *en passant*, that on one occasion the addition of a vessel of this character before (and in addition to) a stand of plain pipe condensers added to the illuminating power of the gas made, 1 to 1.5 candles.

Of condensers proper, we have several forms. The pipe condenser, formed of pipes placed vertically, and suitably connected to allow the passage of gas through each, the gas being cooled by radiation. This style is old, inefficient, and nearly obsolete. Atmospheric condensers are of various forms, usually large annular pipes placed vertically, and connected by diagonal pipes, the gas passing through each annular successively. A condenser of this description is decidedly better than one formed of pipe alone, giving us the benefit of the cooling surface of the outer diameter, as well as that of the inner or air opening. The gas being also passed in a thin stratum, is much more efficiently cooled than in plain pipe condensers. This form of condenser is not, however, received with much favor in this country. My experience some years ago with one built of *wrought iron* gave me excellent results. In general style it was patterned after the Kirkham—cast iron base and diagonal pipes. The twelve annulars were built of No. 12 B.G. iron, were 14 ft. high, 18 in. outer diameter, 12 in. diameter air opening. With a daily make approximating 200,000 cubic feet, this condenser was all that could be desired.

The best feature of such a condenser, to my mind, is the gradual lowering of the temperature of the gas. This *may* mean a larger outlay of money, and a little more room for greater condensing surface; but I am of the opinion that, *should* such be true, the results obtained by use of the atmospheric condenser would offset any such expense.

Let us briefly notice the multitubular. This consists of a series of pipes, usually vertical, in size and number suited to the duty they have to perform, and properly connected at bottom and top. A cast iron casing incloses them, and the water with which it is filled can be regulated in temperature by means of in and outflow. From the very general adoption of this style of condenser in works making from 200,000 cubic feet, and upward, daily, they must possess the merit of "filling the bill."

I have seen the Pelouze and Audouin condenser at work in several works, and have heard it highly spoken of by those using it. Mr. R. B. Taber, of New Bedford, Mass., in his remarks* before the last meeting of the American Association, speaks highly of its efficiency; and I do not doubt but that it would prove a valuable addition to any gas plant.

We have also the Smith & Farmer, the Livesey, and others, whose construction and properties you are all no doubt familiar with. But let them be called "ziz-zag," "sinuous," "friction," or what-not; let the material with which they are filled be iron plates, wooden slats, bricks, boulders, or anything else, the object to be obtained is the same, viz., to increase the internal surface of the apparatus, subdivide the gas, and prolong, as far as possible, its contact with surface, wet and dripping with tarry matter rich in illuminants.

The condensation of gas begins on its evolution from the retort, and is not *complete* before reaching the purifiers—not always then—so that all apparatus, from hydraulic main to purifiers must be considered as taking a part in the process of condensation. The arrangement would be as follows: A vessel of suitable shape and ample size, well filled with slats, division plates, or anything to give great surface, and insure free passage of gas, and kept at a temperature of 150° to 170° F.; next, a Pelouze and Audouin condenser; then pass to an atmospheric condenser; following this a Livesey scrubber and washer, all suited in size to the requirements of your works. With careful attention, then, to the manipulation of these, avoiding, above all things, *too rapid change in the temperature* of your gas, you will be able to deliver the gas to the purifiers in excellent condition to be acted upon by the material used for purifying, and in candle power all that could be desired.

Thus far nothing has been said as to "elimination of tar;" and I think as little remains to be said. My experience has been that if gas is subjected to the above described treatment you will have pretty effectually eliminated all tar from the gas by the time it reaches the purifiers.

* See JOURNAL, Nov. 16, 1886, p. 292.

Discussion.

[Secretary Butterworth here exhibited and explained a diagram showing the plan adopted at the Columbus gas works for the condensation and elimination of tar.]

A Member—Is that plan of condensation based on the Livesey principle—a series of boards standing on edge?

Secy. Butterworth—That is the plan of arrangement; but whether it is on that particular principle or not I cannot say.

A Member—We have found that plan very practicable, and have received very great benefit from it.

A Member—Is it presumed that the gas in its course through the washer and scrubber absorbs any moisture from the water?

Secy. Butterworth—I do not take it that it does.

Mr. Carroll—We have had some experience at Steubenville with this tar subject. We had very great difficulty in keeping tar out of our purifiers, and at the outset I used an apparatus somewhat similar in arrangement to that shown by the Secretary, but was not successful with it. I then dug a tunnel, and carried a line of pipe some 70 feet back from the washer or scrubber, returning it the same distance. That succeeded in doing away with the tar trouble in our purifiers, but the practice seemed to favor somewhat the formation of naphthaline deposits in the apparatus. These deposits, however, were so slight that we still work under the method outlined, and get along very well.

Mr. Canby—We have had no trouble at Bellefontaine in taking the tar out of our gas for some three years. We have had a Pelouze and Audouin condenser in use for three or four years, and before its employment we had considerable trouble with the tar in the bottom of our purifiers; but since the condenser was added our purifiers have been as dry as we could wish them to be. This condenser seems to break up all the globules of tar floating from the hydraulic main. I think the use of that machine will overcome the tar trouble. Its results have been very satisfactory with us.

Mr. Dittmar—Three years ago we overhauled our Troy works, and then put in a steam jet exhauster, which was set, I would judge, about from 40 to 50 feet from the hydraulic main. The gas next passes through a scrubber, then it enters an annular condenser, and passes on to and through a washer. There the trouble commences. From there into the seal heavy naphthaline deposits accumulate. About twice a week I have to clean out the pipes. I have tried everything imaginable to avoid it, but without success. I would like to know if anyone can suggest a plan by which I can get rid of that naphthaline? My only remedy now is to have a man clean it out twice a week.

The President—You want the naphthaline eliminated instead of the tar?

Mr. Dittmar—That is it.

Secy. Butterworth—I would like to ask Mr. Dittmar if he knows how much cooler the gas is on leaving the washer than it was before it entered it? Has he made any test of the temperature of the gas after and before the washer?

Mr. Dittmar—No, I have not.

Mr. Carroll—I think I shall have to explain that in the course of the improvements made at our works we placed one of our condensers at the end of the hydraulic main, and from that the gas passed through the 70 feet of pipe to our exhauster. Having passed the exhauster it enters the multitubular condenser, and from the multitubular it passes on to the scrubber. The pipe extension spoken of was made from the multitubular condenser out into the arch, for the purpose of extending the washer. There is where we caught the principal part of the tar—in front and rear. We found that the spray we had did not amount to anything; but after we improved the spray we took every particle of tar out, and also found less development of naphthaline. We have never been troubled much with naphthaline. I find that there is a very great variation in the amount of trouble caused by stoppages, from one cause or another, in the pipes of a gas works, which difference is, in part at least, traceable to the sort of coal carbonized.

Mr. Wood—We have never been bothered with stopped stand-pipes in the retort house, or around the works. I cannot say anything on the subject, never having been bothered in that way—although I do not know why we should be free from the difficulties that beset others.

The President—Is your system of condensation and scrubbing different from that of others?

Mr. Wood—No; it seems to be practically the same. We run out through the tar extractor first, then through the friction condenser, and then through the scrubber. We use a fine spray, and have no trouble at all.

The President—Mr. Walker has had considerable experience and opportunity for observation. Perhaps he can tell us something about it.

Mr. Walker—I do not know that I can say anything of interest on the

subject, although I travel around the country considerably. I have seen such a variety of condensers and apparatus for eliminating tar and naphthaline in its various forms, that it is pretty hard for me to tell which one to describe. The fact is that every man in the gas business has his own ideas with regard to his mode of running a works. The results accomplished in different works are dependent almost entirely upon local circumstances; and what will apply to one works will, in very few cases, apply to another. Condensation is performed in a great many ways by condensers of the plain atmospheric form, as well as by the annular multitubular sorts. Were I operating a gas works on my own account I would be in position to speak to you of the plans which had my preference, but not being directly connected with a works I cannot speak from present practical experience. Some years ago, in works with which I was then connected, we used multitubular condensers, and found them to work satisfactorily, although we found, in some instances, that the cooling was effected too quickly. We altered that after a time, and then our condensers worked better. We also put in what we call a hot scrubber, for the elimination of naphthaline, which was very successful in its operation. We operated that for a little over a year. I do not think any plant in the country was ever more cursed with naphthaline than the one with which I was then connected. We started with the hot scrubber, as we called it, in the winter, when the temperature ranged from about zero to 15° or 20° below. Before we commenced to use this hot scrubber we were carbonizing about 10 per cent. of cannel to keep our gas up to about seventeen candles. Then we had naphthaline all over—in fact so much of it that we had to shut down the works. We had it in every piece of apparatus throughout the works—in the station meters, purifiers, the condensers and scrubbers. We had to stop and clean it out. Then we started this hot scrubber—or, rather, it was a hot scrubber so constructed that heat could be applied outside the scrubber to raise the temperature of the gas after it left the hydraulic main. The scrubber was arranged so as to break the gas up very fine—that is, to break up all the small globules which are held in suspension. We found, after running that for about ten days, that our candle power—still keeping up the same amount of cannel—was increasing. We did not wish to give our consumers too good a gas, so we cut down the cannel. After running 15 or 20 days we found that we were keeping the quality fully up to the required candle power, and were using less than three per cent. of cannel to attain that end. Having thoroughly cleaned the pipes and then started the plan heretofore mentioned, we were no longer troubled by naphthaline deposits. We worked at as high heats as anybody else did at that time—ten years ago—and got a good yield out of our coal; the average yield per pound, I think, was about 4.90. However, what would apply in that respect in those works might not answer in all others; but in some it would no doubt prove satisfactory. We formed the opinion that that method of working was most efficacious, not for the destruction of naphthaline, but to enable us to utilize it in enriching the quality of our gas.

Mr. Bierce—What method did you follow in cleaning out your apparatus when the same was clogged with naphthaline?

Mr. Walker—Our method, I might say, was accidentally developed; but, accidental or not, it was most complete. We experimented with wood gas. If there is anything under heaven that will thoroughly clean out the clogged pipes of an old gas works, let the stoppages be from naphthaline, tar or any other conglomeration, it is to treat them to a dose of wood gas. It is about as good an emetic as can be given to any gas works.

Mr. Bierce—I have had somewhat the same experience in a works that I have just undertaken to manage. Being a little ambitious, and desirous to get more gas out of coal than they had been in the habit of getting, the pipes became choked up with naphthaline. The difficulty began just after the gas issued from the exhauster; and to remedy it I introduced jets of steam, which melted it. At a point between the purifier outlets and the inlets to the holders I found that an injection of gasoline of high specific gravity gave relief. It evaporates the naphthaline and carries it on forward, but I have not yet found whether or not it is likely to reappear further on—say in the street mains, etc.

Mr. Ross—My experience has been somewhat similar to that reported by Mr. Dittmar. In fact, my trouble, like his, dated from the introduction of a jet exhauster. The entire works seemed to be choked up with naphthaline crystals—the center-seal, purifiers, etc. I experimented, and the result is that I now rely on steam to melt it out, and run it off to the drips.

Mr. Carroll—It is usual, as I understand, to run those multitubular condensers filled with water; but we have never used water in ours. I think that probably we keep our pipes measurably free from naphthaline simply by reason of the degree of heat that we carry through them.

Mr. Canby—I am a firm believer in hot scrubbing. Since I have used hot scrubbers I have had no such trouble with naphthaline as I had before. In fact, for the last two years I do not think I have had any crystals of naphthaline to bother me at all. Before I adopted hot scrubbing the case was very different.

On motion of Mr. Padan, a vote of thanks was tendered to Mr. Bates.

(To be concluded.)

Is Lofty Guide Framing Necessary for Large Gasholders?

The London *Journal* thus calmly discusses a rather revolutionary idea in the principles and practice involved in the construction of "lofty gasholders," but we cannot forbear from expressing the thought that our contemporary's comment does not feel that inward ease in regard to the matter discussed which usually accompanies a dissertation written by one who thoroughly believes in the stability of the thesis advanced. However, this is what our contemporary says on the subject:

The question as to what is the precise value of gasholder framing is one that has been raised several times by engineers with a propensity for diving after abstract principles of construction, but has not yet been settled, or even placed upon the road that may lead to settlement. There have been suggestions for center-pillar holders, and for concentric holders which should hold each other up; but the only practical experiment to test the principles of gasholder framing which has yet been carried out upon the theory that the old-established notions concerning the stability of these structures was erroneous, is the well-known three-lift holder at the Old Kent Road works, which served as a model for the holders at Windsor Street, Birmingham. During the coming summer, however, another step will be taken in the same direction, as a gasholder at the Rotherhithe works of the South Metropolitan Company will be enlarged by the addition of a third lift, *without raising the guide-framing to the additional height*. This new departure in gasholder design is the logical development by Mr. George Livesey of the leading ideas expressed in his Kent Road holder, and still more strongly exemplified in the four-lift holder now being erected by Messrs. Ashmore, Benson, Pease & Co., Limited, at East Greenwich. The spectacle of a gasholder rising a whole lift above its guides, with its useless top carriages feeling abroad, as it were, for support and finding none, will, to say the least of it, be an odd one. It will be eminently a sight to startle one's ideas out of routine conceptions of the principles of gasholder guiding; and this is probably one of the reasons why Mr. Livesey determined upon the experiment. The saving by dispensing with the framing for the additional lift will not in this instance be great. But behind it lies the whole problem of the utility and office of guide-framing in general; and this is large enough. In view of this somewhat startling novelty—which, by the way, may be commended to the careful study of those highly-trained Continental engineers whose mathematical minds have not yet led them to approve of the idea of ordinary double-lift holders—it may not be out of place here to consider briefly the most obvious problems in connection with the stability of gasholders in general.

First, then, what is the object of the exterior framework of a gasholder? It is primarily to provide a means of guiding the movable vessel along its vertical path. In this aspect it is a railway set on end, up and down which the cylindrical tank of gas moves slowly, and is maintained in place while resting. The first conditions of such an arrangement are rigidity and truth of line. Both ends of the line of railway must be as steady as they can possibly be made. In most holders the steadiness of the lower or tank end is readily assured, because the bedding of the "permanent way" is unyielding masonry. It is usually sought to provide for the rigidity of the other end of the track, which is in the air at a greater or less distance from the source of origin—the ground—by laying it along heavy columns or along cantilevers firmly stayed in their places and tied to the ground by strong diagonal rods. Now, it is evident that, in order to be of any service at all, this guiding structure must not only be rigid, but must preserve its rigidity under the greatest stress that can be brought upon it. This is the essence of the theory of guiding a gasholder by an independent exterior framing. The theory is that the holder itself is utterly unable to stand unless held up by a rigid set of supports, strong enough to endure all the strain of the unstable bulk which they inclose, under the influence of any imaginable storm and tempest. It may be a little startling to those constructors who hold this view, but it is nevertheless true that, according to this theory, every gasholder in England ought to be a wreck before the week is out. *It is impossible to construct a framework strong enough to uphold a gasholder of any considerable size, without depending upon the inherent stability of the holder itself.* In other words, there is in the construction of gas-

holders a point, depending entirely upon their bulk, beyond which these structures are wholly independent of the exterior framing with which it is at present thought necessary to provide them. If this were not true, the erection in the open air of holders surpassing 40 or 50 feet in diameter, and 30 to 40 feet high, would have been impossible. As soon as this limit had been passed, every gale would have swept the land clear of gasholders, and the larger ones would all have been inclosed in storm-proof buildings.

The truth as it applies to gasholders is in strict analogy to the conditions of a State and of individual life. (This is not advanced as a proof of the contention, but only in illustration of it.) When the gasholder is small, light, and comparable to a balloon, it must and can be guided and kept in its proper place by external means of control; just as when a State is inchoate, or an individual young, the ruler and the tutor can exercise a necessary training and repressive power. There comes a stage, however, in the development of gasholders, as of men and of nations, when external guidance is impossible, and the structure, like the organism, must stand or fall by its own intrinsic quality of stability or the lack thereof. Analogies, as already observed, are not proofs; but they enable one to indicate succinctly the meaning which it is intended to convey. What we mean in the present argument is that for large gasholders lofty exterior framing, as at present constructed, might and in time will be dispensed with.

It is necessary, however, to enlarge a little upon the grounds for this doctrine, which may be easily misinterpreted. It is admitted that gasholders must rise truly and easily; but the point now under discussion is whether the usual exterior framing has anything to do with the fulfillment of this function by holders of large size. In face of all tradition and established usage, we believe that this framing is a superfluous survival, in the case of large gasholders, of an appurtenance which is only necessary for those small holders from which the larger ones have been developed by gradual enlargements; and that any engineer, if he were called upon to construct gasholders of the class and dimensions now common, without reference, conscious or unconscious, to the practice of the builders of small holders, could effect his object without any exterior framing standing more than a very few feet above the level of the water in the tank, or at most to the height of the inner lift.

The considerations upon which this opinion rests are few in number, and capable of easy verification. In the first place, let us take the example of any large holder framed, according to the old-fashioned way, with heavy columns and tiers of horizontal girders. Regard these columns as cantilevers with a weight applied at the top, or free end, at the highest point where the top carriage roller of the upper lift of the holder touches the guide-rail, and calculate the weight that with this leverage would break the holding-down bolts or crush the compression side of the column. It is a mere computation of the effect in a lever of the first kind of a pressure applied in a ordinary way; and the immediate result of such a calculation will be to show that very little weight can ever have come upon the extreme top end of the lever. In a column 100 feet high every ton of side pressure at the top becomes 100 tons on a fulcrum 1 foot from the point of resistance to overturning at the ground line, where the strength and rigidity must be provided, if at all. The only good effect of all devices of columns, girders, diagonal ties, and the rest of the usual elaborate guiding structure, is to transmit the strain to the ground as directly as possible. There is no strength in the members up in the air. All they are good for is to preserve a rigidity of form, and to send their burdens down to earth without getting forced out of shape in so doing.

Now comes the great question: Why employ elaborate and costly independent framing to transmit to earth the sideways pressures of a gasholder, when you have the holder itself to do it? In every large holder extant stability has proceeded from two factors—dead weight and tight bottom rollers. Without these no outside framing that was ever erected could save a holder from wreck by the first sou'-wester; with them, the outer guiding structure becomes of very minor importance. With regard to the effect of dead weight, we know that the extreme wind pressures occasionally registered by anemometers are illusory; and we have every reason to believe that no gasholder in the United Kingdom was ever subjected to a wind pressure of 20 lbs. per square foot. Taking this figure, however, for the sake of safety, we will assume the case of a three-lift holder 150 feet in diameter and 100 feet high, which is rather an extreme proportion of height to base. A gasholder is supposed, being cylindrical, to expose (say) two-thirds as much area as a vertical plane to the direct effect of the wind; so that in a gale of the presumed force the holder would receive a horizontal push of 200,000 lbs., and even this would not be constant. To resist this, if the holder gave a pressure of 40-10ths, there would be a dead weight of 368,200 lbs. Place a block weighing 368 lbs. on a smooth, level plain, and hang to it a weight of

200 lbs. by a line passing over the edge of the plane through a pulley—how much force would the former exert against an upright designed to maintain it in position? Next, with regard to the bottom rollers, it is a striking fact that no gasholder was ever yet known to fall over unless the bottom curb rose above the edge of the tank, or the bottom rollers became in some way displaced. This is simply because in the holder, as in the outer framing, the only stay and holdfast is in the ground; and the holder must transmit its strains to the ground, which it can only do through its bottom rollers. Every puff of wind tends to press inward the side sheets against the outward stress of the confined gas; and these pressures and counter pressures would rock the holder if it were free to move. But all this is checked by the bottom rollers. Here, then, at its base, not at the top, is the place whence the stability of a gasholder must be provided for, if at all. With a strong bottom curb—a horizontal web-girder of steel, if the structure is large enough to need it—and strong, well-adjusted bottom rollers in a double tier a few feet apart vertically, the largest holder might be built in perfect security, and never feel the want of that elaborate above-ground guiding structure which costs so much money, gives so much trouble, and takes such a long time to build, and, unless very well adjusted to the rollers, does infinitely more harm than good.

Standard Pipe and Pipe Threads.

A recent issue of the *Stevens' Indicator* (a technical publication connected with the Stevens' Institute, Hoboken, N. J.), in discussing the above subject, says:

The chaotic state in which the matter of standard pipe threads has been for years, both here and abroad, has finally had the effect of arousing American engineers at least to vigorous action. As a result the whole subject has been thoroughly overhauled by a committee appointed somewhat over a year ago by the American Society of Mechanical Engineers, in conjunction with committees of United States manufacturers of wrought iron and boiler tubes, and brass and cast iron fittings. The outcome of their work was embodied in an exceedingly interesting report submitted to the American Society of Mechanical Engineers at their last annual meeting (November 29th—December 3d, 1886), and which has just been issued in pamphlet form.

Without going into all the details which it was desirable to give in this report, it will suffice for our purpose to note that after an endless amount of correspondence, a large number of committee meetings, and the examination and test of many samples of threaded pipe, the several associations of manufacturers resolved to adopt and adhere to the original Briggs standard of gauges. Comprehensive information regarding the subject of standard pipe and pipe threads as applied in American practice is given in the Excerpt Minutes of "Proceedings" of the British Institution of Civil Engineers (session 1882-83, Part I.), containing the paper of the late Robert Briggs on American Practice in Warming Buildings by Steam. Referring specially, however, to the matter here considered, we take from the report before us the following, from the text and tables of Mr. Briggs's paper, giving completely the data upon which the Briggs standard pipe thread sizes are based:

The taper employed for the conical tube-ends is uniform with all makers of tubes or fittings—namely, an inclination of 1 in 32 to the axis. Custom has established also a peculiar length of screwed end for each different diameter of tube. Tubes of the several diameters are kept in stock by manufacturers and merchants, and form the basis of a regular trade in the apparatus for warming by steam. The ruling dimension in wrought iron tube work is the external diameter of certain nominal sizes which are designated roughly according to their internal diameter. These nominal sizes were mainly established in the English tube trade between 1820 and 1840, and certain pitches of screw thread were then adopted for them, the coarseness of the pitch varying roughly with the diameter, but in an arbitrary way utterly devoid of regularity. The length of the screwed portion on the tube end varies with the external diameter of the tube according to an arbitrary rule-of-thumb; whence results for each size of tube a certain minimum thickness of metal at the outer extremity of the tapering screwed tube end. It is the determination of this minimum thickness of metal for the tapering screwed end of wrought iron tube which constitutes the question of mechanical interest.

For a tapering tube end for a nominal 2½-in. tube—that is, a tube of about 2½ in. internal diameter and 2¾ in. actual external diameter—the following particulars are given: The thread employed has an angle of 60°; it is slightly rounded off both at the top and at the bottom, so that the height or depth of the thread, instead of being exactly equal to the pitch, is only four-fifths of the pitch, or equal to

$$(0.8)\frac{1}{n}, \text{ if } n \text{ be the number of threads per inch.}$$

For the length of tube end throughout which the screw thread continues perfect, the empirical formula used is—

$$(0.8 D \times 4.8 \times \frac{1}{n})$$

where D is the actual external diameter of the tube throughout its parallel length, and is expressed in inches. Further back, beyond the perfect threads, come two having the same taper at the bottom, but imperfect at the top. The remaining imperfect portion of the screw thread furthest back from the extremity of the tube is not essential in any way to this system of joint, and its imperfection is simply incidental to the process of cutting the thread at a single operation. From the foregoing it follows that, at the very extremity of the tube, the bottom of the diameter of the thread is—

$$D \times \left[\frac{2 \times (0.8 D \times 4.8)}{32n} + \frac{2 \times 0.8}{n} \right] = D - (0.05 D + 1.9) \times \frac{1}{n}$$

The thickness of iron below the bottom of the thread, at the tube extremity, is empirically taken to be = 0.0175 D + 0.025. Hence the actual internal diameter d of any tube is found to be, in inches—

$$d = D - (0.05 D + 1.9) \times \frac{1}{n} - 2 \times (0.0175 D + 0.025)$$

or—

$$d = 0.965 D - 0.05 \frac{D}{n} - \frac{1.9}{n} - 0.05$$

For the various sizes of tubes ranging from ½ in. to 10 in. internal diameter, with their corresponding numbers of screw threads per inch, the actual internal diameter of d is expressed by the following Table I. in terms of the actual external diameter D .

TABLE I.—Diameters of Wrought Iron Welded Tubes.

Nominal Internal Diameter of Tube. Inches.	No. of Screw Threads per Inch. No.	Actual Internal Diameter d in Terms of Actual External Diameter D . Inches.
½	27	$d = 0.9631 D - 0.1204$
¾ and ⅝	18	$d = 0.9622 D - 0.1556$
1 and ⅞	14	$d = 0.9614 D - 0.1887$
1, 1¼, 1½, and 2	11½	$d = 0.9607 D - 0.2152$
2½ to 10	8	$d = 0.9587 D - 0.2875$

The figures derived from this statement, which are of importance for practical use, are presented in detail in Table II. in a convenient order for reference.

The number of screw threads per inch for the several sizes of tubes is here accepted from customary usage. It is the workman's approximation of the pitch practically desired, and much reluctance must consequently be felt in calling it into question. Still it would have been better to investigate the general case upon the basis of a pitch ranging in closer accordance with the range of tube diameter. Thus the nominal ½-in. tubes might have had 16 threads per inch; ¾-in., 14 threads; 1 and 1¼-in., 12 threads; 1½ and 2-in., 11 threads; 2½ to 3½-in., 10 threads; 4 to 6-in., 8 threads; 7 to 9-in., 7 threads; and 10-in., not more than 6 threads per inch. The existing number of threads, however, as given in Tables I. and II., are now too well established to be disturbed; at all events they must be taken in any statement of present practice.

TABLE II.—Standard Dimensions of Wrought Iron Welded Tubes.

Diameter of Tube.			Screwed Ends.		
Nominal Inside. Inches.	Actual Inside. Inches.	Actual Outside. Inches.	Thickness of Metal. Inches.	No. Threads per Inch.	Length of Perfect Screw. Inches.
½	0.270	0.405	0.068	27	0.19
¾	0.364	0.540	0.088	18	0.29
⅝	0.494	0.675	0.091	18	0.30
1	0.623	0.840	0.109	14	0.39
1¼	0.824	1.050	0.113	14	0.40
1½	1.048	1.315	0.134	11½	0.51
2	1.380	1.660	0.140	11½	0.54
2½	1.610	1.900	0.145	11½	0.55
3	2.067	2.375	0.154	11½	0.58
3½	2.468	2.875	0.204	8	0.89
4	3.067	3.500	0.217	8	0.95
4½	3.548	4.000	0.226	8	1.00
5	4.026	4.500	0.237	8	1.05
6	4.508	5.000	0.246	8	1.10
7	5.045	5.563	0.259	8	1.16
8	6.065	6.625	0.280	8	1.26
9	7.023	7.625	0.391	8	1.36
10	8.982	8.625	0.322	8	1.46
	9.000	9.688	0.344	8	1.57
	10.019	10.750	0.336	8	1.68

Taper of conical tube ends, 1 in 32 to axis of tube.

SPECIAL ENGLISH CORRESPONDENCE.

COMMUNICATED BY NORTON H. HUMPHRYS.

SALISBURY, April 9, 1887.

Oil Gas in England.—New Way of Utilizing Coke.—Paris Gas.—The Status of Gas Engineers.—Honesty is the Best Policy.—Novel Views Respecting Gasholder Guide Framing.—Pushing the use of Gas Cooking Stoves.

There seems to be good reason for believing that coal will not continue to be the sole material for gas manufacture in this country, as it has been in the past. Some 50 years ago oil was tried, and undertakings were established with the object of supplying oil gas, but it was soon found that the oil was too expensive, and that they must either liquidate or take to coal; so, wherever it was practicable, the latter course was adopted, and the title "oil gas" dropped out of use. Since that time oil has been used to a very limited extent for the production of oil gas for railway carriage lighting, and a few other purposes in which gas of 50 or 60 candle power was a desideratum; but it has altogether been thrown on one side by gas companies in the ordinary way. The supply of cheap petroleum, paraffine and shale oil is now once more directing attention to the gas producing capabilities of hydrocarbon fluids. A company has been formed at Glasgow for the purpose of working a system of making gas from paraffine, and they are about to give their system a practical trial at Linsburg, a small town of some 500 inhabitants, requiring, perhaps, one million cubic feet of gas per annum. The gas is said to be of about 60 candle power, and it will be interesting to know how much of this is actually obtained in the consumer's house. Mr. G. Bower, the well-known gas engineer and contractor, of St. Neots, in a letter addressed to the *Journal of Gas Lighting*, points out that it is now 25 years since he commenced to supply sets of oil apparatus for India and other parts of the world, where the cost of coal was such as to prohibit its use. This apparatus was capable, he says, of producing 25,000 cubic feet of 50-candle gas per ton of oil used. If the gas was considered too rich the only suitable diluent was weak carburetted hydrogen—that is, coal gas of poor quality—as, if carbonic oxide, hydrogen or air were used, the result would be a less total illuminating power per ton of oil than if the gas was used in an undiluted state. The only impurity to be removed was a little carbonic acid, and the gas would mix readily with weaker gases.

In the same communication Mr. Bower has a suggestion to make about coke, for adoption in districts where coke suitable for foundry or locomotive purposes is costly. This is that the breeze and coke be pulverized and mixed with about one-fourth its weight of coal tar pitch. This mixture is to be coked in an ordinary coke oven, and Mr. Bower anticipates that the product will be suitable both for the foundry and the locomotive. In many districts foundry coke will realize three times the price paid for good gas coke, so that, if this operation proves successful in practice, it will add materially to the revenues of gas undertakings. The idea also possesses the specially attractive feature that breeze and screenings, which in many districts are almost valueless, could also be included and treated in this way. Various endeavors have been made in the direction of the manufacture of a good quality foundry coke, in the course of the destructive distillation of coal for the production of illuminating gas, but they have mostly aimed at special treatment of the coal in large or specially shaped retorts. The advantages of a process that admits the coal being heated in any way desired, for the production of the best possible results in the shape of illuminating gas, in bringing in any screenings or breeze that has not been through a furnace, and of utilizing the principal product from coal tar, are too obvious to need further comment.

The municipality of Paris do not let the local gas company alone for any length of time, nor is it to be expected that, so long as the present arrangement by which a high price to the consumer is guaranteed, whatever else may happen, is allowed to continue, the representatives of the public will be able to retain their seats without keeping up some sort of a show of opposition. The municipality are in an awkward position in this matter, because they accept a large share of the gas company's profits, according to the agreement, and are therefore very much in the position of the receiver of a bribe; or we may liken them to a gas engineer who, having betrayed his trust by accepting a large commission from a contractor, is called upon by his directors to object to the goods supplied. Lately they have decided that the existing methods of testing gas for illuminating value, for sulphuretted hydrogen by means of lead paper, etc., are insufficient, and that in the future the gas is to be analyzed, with a view of detecting the presence of any objectionable ingredient, such as carbonic oxide, ammonia, or other substance that is poisonous, likely to produce unwholesome fumes, or to affect the value of the gas. The results of such tests are likely to be of interest and value to the

profession, if properly and accurately conducted, but it is difficult to see how they will be of any practical use in the face of existing agreements. This new move is interesting in view of the fact that a certain small clique in England have occasionally agitated for the valuation of coal gas by analysis. Most experiments in this direction, however, go to prove that all known methods of gas analysis fail to yield concordant results, so far as the actual illuminating value is concerned, whilst the existing tests are quite sufficient on the score of purity.

I have refrained from referring to the matter known as the "Salford gas scandal" until the public excitement attending the matter has passed over, as so many strange rumors and assertions found their way into print about it as to render the separation of the true from the false a matter of some difficulty. It appears that Mr. Hunter, the gas engineer to the Corporation of Salford, an important suburb of Manchester, brought an action for libel against a coal contractor, Mr. Ellis Lever, the said libel consisting of the assertion that Mr. Hunter was guilty of bribery and corruption, being in the habit of accepting bribes from parties supplying goods for the gas works. Placed on his defense, Mr. Lever proved to the satisfaction of the court that these assertions were substantially true, and the case was consequently dismissed. Mr. Hunter was, of course, virtually condemned, and was summarily dismissed from office. In every class of life there are persons who overstep the limits of the law, therefore the existence of one such in the ranks of the 8,000 gas managers in the United Kingdom (whilst all agree in deploring it) would not be a matter of general interest but for the extraordinary attitude that some sections of the public press have taken towards it. They have accepted the extraordinary exposures at Salford as an indication of the usual customs in the gas engineering profession, and the newspapers and magazines of the day abound with expressions to the effect that gas engineers, as a body, expect "tips," that the principal object of gas engineers associations is to decide upon the firms from whom the heaviest bribes can be extracted, and that it is impossible for firms depending entirely upon the supply of gas works necessities to get an *honest* living. Applying this absurd method of reasoning, there is not a single respectable trade or profession in the country. Bankers are swindlers, ministers of religion are licentious hypocrites, stockholders are knaves, and lawyers are no better, shopkeepers are cheats and adulterators, and so on. It is also singular to notice that the giver of the bribe is entirely exonerated by these touters, who are willing to cast mud at innocent people so long as they tickle the public fancy. They draw the absurd and impossible portrait of a gas engineer all but advertising for "who will give the highest bribe." No one, however unscrupulous, would be so reckless as to follow this course. The more reasonable supposition is that the delicate fact that a "tip" is obtainable is carefully and subtly put out by the giver. With all this vaporizing the fact remains that the majority of gas engineers deservedly enjoy the confidences of their directors, having no transactions with contractors or suppliers of goods that are of a secret or underhand nature. Nor is this ignorant maliciousness likely to do them permanent harm. I do not hold up gas engineers as a pattern of commercial morality to the rest of the world, but I do claim that, as persons chosen to fill a responsible office, and intrusted with large interests, personally selected with due care and inquiry as to character, the instances in which any abuse of the confidence placed in them exists are very few and far between.

Gas engineers, apart from conscientious considerations, are well aware that "honesty is the best policy," and a certain Mr. Alfred Simmonds, a master gas fitter of Berkhamstead, who evidently was not trammelled with any scruples of this kind, has received a practical proof of the truth of this proverb. Mr. Simmonds, fully aware from the nature of his calling inherent to the use of coal gas, inclosed his gas meter in a box, with the ostensible object of "preventing the children from tampering with it." But the innocent looking box also served to cover a bye-pass pipe, affording a direct supply from the service pipe without passing through the meter. This was discovered by the gas officials before any considerable quantity of gas could be thus surreptitiously obtained, and the cautious gas fitter was promptly summoned to explain his conduct before the magistrates. As the upshot of this interview Mr. Simmonds was called upon to hand over the sum of \$100; so his lesson in honesty was rather costly.

An article* which recently appeared in the *Journal of Gas Lighting* is devoted to the discussion of the necessity for guide framing in connection with large gasholders. The subject is viewed from a novel standpoint. The general impression in the profession is that a strong framework is necessary to retain the holder in its place, and to resist the over-throwing action of wind. So it has always been the rule not only to continue the framework up to the highest point reached by the holder

* See page 284.

carriages, but to take special care that it should be thoroughly rigid and strong. Heavy cast iron columns were considered an important adjunct at first, but latterly these have given way to a cheaper way of effecting the same result, viz., diagonal bracing and tie rods, so arranged as to convert the whole frame into a rigid ring or cylinder. According to the view now advanced all this is just so much labor wasted. It is stated that the inherent stability of the holder itself is sufficient to resist any wind stress yet experienced in this country, and that the purpose served by the frame is simply that of a guide, and that the real source of strength and resistance is not the guide framing, but the bottom of the curb of the holder. In proof of this it is pointed out that no holder has yet been known to be overturned unless the bottom curb was first tilted out of place and lodged on the edge of the tank at one part. So it is claimed that, with a strong bottom curb, and well adjusted bottom rollers in a double tier, a few feet apart vertically, a holder would be quite safe with no framing above the tank other than that necessary to receive the upper tier of bottom rollers when the holder was nearly full. Mr. George Livesey is about to test this idea by adding an additional lift to a holder at the Rotherhithe station of the South Metropolitan Gas Company without making any alteration or addition to the guide framing.

A very good way of attracting attention to the use of gas cooking stoves consists in arranging for the delivery of a course of lectures on cookery and domestic economy, illustrated with practical demonstrations carried out by means of gas stoves. If a thoroughly qualified lady lecturer is secured, and the thing properly advertised, a good attendance of ladies throughout the course will result. A few stoves, of the kind supplied by the gas company can be exhibited in the room, and one or more officials from the gas works should be in attendance to take orders, explain the stoves, etc. A good opportunity is afforded for a few remarks on the general subject of gas supply, and these may be introduced by the manager, or one of the directors, either at the commencement or close of any lecture. Objects of interest, models, diagrams, etc., may also be exhibited in the room. It is better to make a small charge for admission rather than to issue free tickets to the consumers. Such a plan may be thoroughly carried out at a cost of not more than \$50 to the gas company, and it answers most efficiently as a taking advertisement. Such, at least, is the experience in several towns in this country where it has been tried.

ITEMS OF INTEREST FROM VARIOUS LOCALITIES.

THE COLUMBUS (OHIO) GAS COMPANY PROCLAIMS THE DOLLAR RATE.—Some time ago in the not very dim past either one of our sages ventured the assertion that the Star of Empire was likely to "wend its way" in the direction of the West; and the sage, judging from the progress achieved in the development of the West, which judgment must needs guide the horsoscooper not entitled to lay claim to sage-like wisdom, evidently knew whereof he spoke. However, gas men, as a rule, are more interested in the "Star's" influence upon their business than in other departments, and we accordingly submit the fact that the "star of cheap gas" is in zenith over Columbus, Ohio—latitude 33° 57' N., longitude, 82° 59' W. The simple facts in the case are that from and after May first the residents of the capital city of the Buckeye State will obtain their gas at the rate of \$1 per thousand cubic feet—coal illuminating gas, too; while the gas furnished to the street lamps will be billed to the city fathers at the rate of 75 cents per thousand—it seems rather strange to be obliged to use the word "cents" in announcing a gas rate, especially when the suppliers of the article in question are but members of a corporate business enterprise liable at any (or all) time to receive the flattering assurance that they are bloodless and soulless monopolists. Of course, it would be a hard job to discover anything possessed of a soul that did not, at one period or another, have more or less blood in circulation; but as the "indignant public" seldom pauses for words wherewith to score its enemies, why, "there's an end o' it." Perhaps one Columbus man may feel sad at the prospect of being cut off from his customary growling at the gas suppliers—that sorrower, of course, being Dr. Robinson; but, on second thought, possibly the Doctor may—if Machiavellian, he will—"point with pride" to the fruition of his efforts for the public good. All hail to the Columbus triumvirate of gas men who performed this great deed—Messrs. Huntington, Robinson (A. B., not the Doctor), and McMillin.

CHEAPER GAS FOR BOSTON, MASS.—The Boston (Mass.) *Transcript* is our authority for the following: "On the 1st of April the Boston Gas Light Company reduced its price for gas from \$1.50 per thousand cubic feet, to \$1.40. When the Company began business, in 1828, the price of gas was \$5 per thousand. The rate gradually fell until the war period, when it rose again, and, on January 1st, 1865, was \$3.25. Five years

later it was reduced to \$3; on April 1st, 1871, the price was \$2.75; July 1st, 1872, it was lowered to \$2.50; April 1st, 1876, to \$2.25; April 1st, 1879, to \$2; Jan. 1st, 1883, to \$1.80; July 1st, 1884, to \$1.50, at which price it has remained until the present time."

ANNUAL ELECTION, AMERICAN METER COMPANY.—At a meeting of the Trustees of the American Meter Company, held at the offices of the Company, 512 West 22d street, this city, on April 19th, the following board of officers was chosen: Geo. J. McGourkey, President; William H. McFadden, Vice-President and Assistant Superintendent, at Philadelphia; Wm. N. Milsted, Treasurer and General Superintendent; Wm. H. Down, Secretary and Assistant Superintendent at New York; Paul S. Merrifield, Assistant Treasurer at New York; and Wm. H. Hopper, Assistant Treasurer at Philadelphia. The Trustees were re-elected. It will be noted from the above list that Mr. T. C. Hopper is succeeded in the Presidency by Mr. McGourkey, formerly Vice-President, and that Mr. McFadden was chosen to fill the vacancy created by Mr. McGourkey's promotion. The retiring President declined a re-election on the ground that he had long desired to seek that immunity from the worriments and cares of active business which his extended and faithful work in the Company's service fairly entitled him to. While loth to accede to the request, his associates finally acquiesced, and Mr. Hopper will now have opportunity to call some portion of his time his own. Before taking leave of this subject we cannot refrain from remarking that the business enterprise which resulted from the union, years ago, of the meter establishments of Down & Merrifield and Code, Hopper & Co., is exceptionally fortunate in the *personnel* of those who carry on the burden of the work. In the new President, Mr. McGourkey, the Company enjoys the services of a man of rare executive ability, and of wonderful financial accumen; in fact no other man is better known, nor enjoys a more brilliant reputation, in the banking circles of New York city, than the newly elected President of the American Meter Company. Regretting the fact that Mr. Hopper *would* resign, we can congratulate him upon the caliber of the man who replaces him at the helm, and the Company upon the felicity of its choice.

AN ITEM FROM FAR-AWAY FARGO.—Fargo (Dakota Ter.) has been supplied with gas for quite a while by a thoroughly live, go-ahead Company, and its promoters have received a fair reward for their enterprise and pluck. Indeed, the original promoters of the Fargo Gas Light and Coke Company were looked upon as having undertaken a rather dangerous contract, but their subsequent success is the best evidence that they knew what they were about. From a letter recently received by us from Mr. L. Gray, Sec. and Supt. of the Company, we take the liberty of extracting the following: "We have obtained a charter for the town of Moorhead, Minn.—just across the Red River from Fargo—which place contains about 3,000 inhabitants, and expect to extend our mains over there this summer. We have also bought out the plant, etc., of the defunct Fargo Brush Electric Light Company, and are now engaged in moving the same to our gas works. Adjoining the latter we have built a brick structure, 32 feet by 38 feet, to contain the dynamos and engine, and have obtained a city contract under which we will light the streets by means of three towers, each to be equipped with six arc lights, to run all night and every night, for the sum of \$360 per month. The contract is to last for three years. Business here is better than for four years back, and is growing still better every day."

PUBLIC LIGHTING AT TROY, N. Y.—At an adjourned meeting of the Troy Contracting Board, held April 16th, it was decided to award the contracts for public lighting in accordance with the following: Troy and Citizens Gas Light Companies to furnish gas to street lamps equipped with three-foot burners at the rate of ten cents per lamp per night; where four-foot burners are in use the charge to be eleven cents per night; both Companies to furnish gas to public buildings at the rate of \$1.75 per thousand cubic feet. The arc lighting portion of contract was given out at 47 cents per light per night, although the electricians contended strenuously for an advance to 50 cents. In fact, as we understand it, the "light-of-the-future" men originally bid 50 cents, but the Contracting Board would not agree to the proposition. Troy's electrical promoters, it is said, are not enjoying a bonanza.

A SIEMENS-LUNGREN COMPANY FOR NEW YORK CITY.—Albany advices state that on April 15th a certificate incorporating the Siemens-Lungren Gas Lamp Company, of New York city, was filed with the Secretary of State. The Company is capitalized in \$100,000.

NEW GAS COMPANY.—Col. C. K. Holliday, of Topeka, Kansas, has secured a contract to build a gas and electric light plant at Arkansas

City, Kansas. Arkansas City was, in 1880, a post village of Cowley county, with a population of less than 2,000; now it is a full fledged city, claiming to have a population of but little less than 10,000, and fairly bubbles over with activity. It boasts of an iron foundry, machine shops, rolling mills, and a \$75,000 hotel. It is located on the Arkansas River, about 14 miles south of Winfield, and is about four miles distant from the boundary line of Indian Territory.

PROPOSING TO START AN OPPOSITION GAS COMPANY.—We learn that, on or about April 12th, Messrs. W. J. Knight, A. Kamman, F. O'Donnell, M. M. Ham, M. M. Walker, and E. T. Kein met for the purpose of organizing an opposition or competing gas company in Dubuque, Iowa. Having discussed the features of the situation, the agitators finally decided to go ahead, and organized by selecting or electing the following board of officers: President, F. O'Donnell; Vice-President, M. M. Walker; Secretary, E. T. Kein; Treasurer, A. Kamman. The capital was fixed at \$160,000, and it is proposed to charge \$1.75 per thousand cubic feet—when ready to supply gas. The Council will be appealed to for the necessary franchise, etc. Mr. Ham, one of the gentlemen who hopes to lubricate his financial future by means of this venture, is reported to have explained, "That it is the purpose of the Company to associate with them a large Eastern Company, with great experience, which will have charge of the business, while the Dubuque stockholders keep the majority of the stock, consequently the control of the organization. Two companies in the East have been looking over the ground, and one of them will undoubtedly come. If the home Company secures liberal rights from the city the richer of the two will take hold and put in an excellent system in Dubuque. If the rights granted by the city are not so liberal the richer company will not take hold of the matter, and it will be left for the other." It is pretty hard to weigh out exactly what Mr. Ham means to convey in the above, save in respect to the fact that, cut up his words as you will, Mr. Ham seems indisposed to cast any of his own fat in the fire—no matter what the proprietors of the "rich" or "lean" Eastern Companies conclude to do with the Dubuque gas range. In the meantime it is more than likely that Brother Howard, of the old Key City Gas Company, will try harder than ever to convince his Board of Directors that they, by reducing the gas rate, could "cure" Mr. Ham and his Eastern coadjutors of any desire to intermeddle in the gas supply of that city.

IMPROVEMENTS AT MONTCLAIR, N. J.—The proprietors of the Montclair Gas Company who have the franchise for supplying gas in Montclair and Bloomfield, have begun the excavation for a gasholder tank in ground on Bloomfield avenue, just east of the railroad crossing. They also propose to replace the present six-inch gas mains, between the works (at Bloomfield) and the town of Montclair, with a ten-inch system.

ANNUAL ELECTION, ROME, N. Y.—At the annual meeting of the stockholders of the Rome Gas Light Company the following board of directors was chosen: Messrs. G. N. Bissell, F. H. Thomas, J. D. Higgins, W. R. Huntington, T. H. Striker, H. G. Utley and N. F. Thomas. Mr. G. N. Bissell was subsequently chosen President.

HOW IT IS DONE AT BROOKLINE, MASS.—The Brookline Gas Company supplies the Suburban Electric Light Company, of same town, with coke and coke screenings for fuel. The latter Company will put in two tubular boilers fitted with the Jarvis boiler setting to economically burn the class of fuel used. The coke is thoroughly wetted before it is fired, and the gas distilled from the combustion of the wet fuel is utilized by the aid of the hot air discharged over the fire through the ducts of the Jarvis furnace.

TONAWANDA APPRECIATES THE SITUATION—but the voters would have it so; although a wail comes from them at present because of the Egyptian darkness that prevails in the South Village after sunset. The voters of Tonawanda, N. Y., at a recent election, voted down the proposed appropriation for street lighting, because they thought such action would force the Gas Company to offer a lower bid, and for the further reason that, when such lower bid was received, another election could be held to accept it. This is the way a local newsman now views the scene: "A law was subsequently discovered which made a second election illegal. It was then thought that a sufficient surplus of last year's appropriation would help things out, but at the latest meeting of the Village Council it was found that the street lighting fund had been overdrawn \$700, which left but one alternative. The Council ordered that the lamps be not lighted, and the order is now (mid-April) in full force. Intense gloom prevails everywhere, when the day is done, and the pedestrians go stumbling along on the uneven sidewalks. The better portion of the

population is indignant, and added to their wrath is a fear of a serious kind. The fund for the maintenance of the police is out, too, and property is at the mercy of thieves, who can best conduct their operations under the cloak of darkness. Never was the village in such a state before, for, even when there were no lamps, a public officer exercised guard over the sleeping inhabitants. What will be done no one knows. There is a great deal of talk, but all tendency to act is wanting. One and only one way is open, and that is to obtain a special act of the Legislature for the holding of an election to approve appropriations." With the present condition of affairs to act as a spur to the memories of Tonawanda's voters, it is likely that hereafter the South Village voter will ponder ere he deposits the silent token of his sovereign will, etc.

A GAS WORKS AT AUCTION.—Under a decision of the Court of Chancery the works of the Columbus (Miss.) Gas Light Company will, on date of May 16th, be disposed of at public sale, by Messrs. E. Gross and G. A. Evans, Commissioners in Chancery. There ought to be some lively bidding on this property, for the town is most eligibly located, and it would seem as if it had quite a future before it. Columbus is on the east bank of the Tombigbee river, is about 150 miles northeast of Jackson, and 98 miles northeast of Meridian. It is easily accessible by rail from other sections of the country, and the Tombigbee furnishes a waterway for fair-sized steamships. It is noted as a shipping point for cotton. Population about 7,500.

CHEAPER GAS FOR ATHENS, OHIO.—We are indebted to Mr. C. H. Welch, Secy. and Supt. of the Athens Gas Light Company, for the information that on and after first instant the Company will supply gas to consumers, using 500 cubic feet and upwards, at the rate of \$2.00 per thousand. In cases where the monthly consumption is less than the specified minimum quantity the former charge (\$2.50) will prevail. During the discussion, at the recent meeting of the Ohio Association, on the papers read by Messrs. Converse and Prichard, Mr. Welch said, among other things, "Although our works at Athens are very small, we nevertheless endeavor in every way to increase the consumption;" and we submit that the latest action taken by his Company is proof positive in support of his Dayton assertion. The Ohio idea at present seems to be in the direction of cutting gas rates, so general is the movement in that regard in the Buckeye State. Stronger may it grow.

FOLLOWING IN HIS FATHER'S FOOTSTEPS.—At a meeting of the directors of the Jacksonville (Ills.) Gas Company, held April 18th, Mr. E. J. King was formally elected to the position of Superintendent. Mr. King succeeds his late father, Mr. J. O. King, an account of whose demise will be found in our editorial pages of the current issue.

A METER ON EXHIBITION.—The average newspaper reader is often treated by his favorite "reflector of public opinion" to a tirade on the untruthfulness of the gas meter; but it must be confessed that the meter does not seem to mind the volume of criticism meted to it, calmly keeping on in the even tenor of its way. Further, meters are usually relegated to the seclusion of a cellar, and are often found in motley company, but even those dispiriting conditions fail, as a rule, to disturb their equilibrium. However, we now have an opportunity to mention one particularly lucky sample of the genus meter, that was "pretty" enough to have been placed on exhibition, and to get its "name in the papers;" therefore, availing ourselves of the chance, partly to "right a wrong," we extract the following from a recent issue of the Hartford (Conn.) *Times*: "The Hartford Gas Company has received and placed on exhibition, in the front window of the Main street office, a large meter which is to be used in the new building of Brown, Thomson & Co. It is a handsomely ornamented affair, and the manufacturers (D. McDonald & Co., of Albany) say it is the finest meter, out of the 101,931 they have made, which has left their shops. It will supply gas to six or seven hundred burners. Messrs. Brown, Thomson & Co. will light all the rooms in their building with gas, and will rent the rooms, gas bills paid."

CHARTERED.—The Overbrook Light and Power Company, of Overbrook, Pa., was chartered on April 19th. Capital, \$30,000.

JARVIS STEAM PLANT FOR THE BURLINGTON (VT.) GAS COMPANY.—The Jarvis Engineering Company, of Boston, Mass., has received a contract under which they will erect a complete steam plant for the Burlington Gas Company. The contractors will fit a tubular boiler on the Jarvis plan of boiler setting, to permit the use of coke screenings for fuel; will supply two Armington & Sims' Company's engines; also will erect one of their new style of chimneys, which, it is said, will cost one-third less than chimneys constructed on the old plan. In fact the Jarvis

folks claim that the new style chimneys cost about the same as iron stacks.

CONSOLIDATED AT BRATTLEBORO, VT.—We are informed that the owners of the Mechanics Gas Company have sold their plant to the old Brattleboro Gas Light Company, receiving therefor something like \$12,000. The latter Company will, as soon as possible, consolidate the plants, and furnish the entire gas supply of the city from the works on the depot grounds. The works of the Mechanics Company, which were formerly owned by the Estey Organ Company, will be closed, and the large factory buildings of the Organ Company are to be lighted by gas from the old Brattleboro plant. A pledge has been made that this consolidation shall not increase gas rates, which is now supplied at the rate of \$2.70 per thousand cubic feet, less ten per cent. for prompt payment.

THE COST OF IT.—A genius of a reporter, who is a member of the staff of the *Chicago Tribune*, has been figuring out what it cost to manufacture each 1,000 cubic feet of gas made by Supt. Green, of the Ohio Penitentiary gas works, during last March. He got the thing down pretty fine—that is, we mean the reporter did, and if he can do anything like as well, if ever he comes East, in this section of the country, we will guarantee him his pick out of at least 100 gas works, whose proprietors will gladly pay him \$25,000 per annum, and present him occasionally with a \$10,000 check. The *Tribune* man figures out the net cost of Ohio Penitentiary gas to have been 15½ cents per thousand cubic feet, on a total make of 3.7 millions. For instance, he gives figures to prove that 3.7 millions cubic feet of gas were purified at a gross cost for material of \$5.26. Then, to show how firmly disposed he was to enter up every item connected with net cost, he charges up “interest on plant, at the rate of 5 per cent. per annum.” Come East, young man: your presence here will fill an “aching void.” But, come to think of it, how could Chicago spare him? For an itemized statement of the Chicago expert's opinion, see *Chicago Tribune*, April 23d.

HASTINGS' GAS RATE.—We understand that the residents of Hastings-on-the-Hudson (N. Y.) are being supplied with gas, at the rate of \$2 per thousand cubic feet.

VENTURA (CAL.) HAS GAS.—The Ventura Gas Company, of San Buenaventura, sent out gas to the residents on the night of April 4th. The Company starts out with 140 meters. This town is the capital of Ventura county, Cal., is located on the Pacific Ocean, at a point 60 odd miles west-by-north of Los Angeles, and is likely to assume importance as a business center.

ELECTRIC LIGHT FOR BISMARCK CITY, DAKOTA TER.—The City Council of Bismarck have granted to Messrs. L. W. Thompson and C. R. Gilman an exclusive privilege, to last for ten years, for the supply of electric lighting in that city. They have also been authorized to put up 12 arc lights (1,200-candle power) on account of the public lighting, and the price at which the service is to be performed was adjusted at 50 cents per arc per night. Sixteen-candle power incandescent lights are to be furnished in the public buildings at a charge not to exceed \$3 each per month. The contractors will supply the Thomson-Houston system.

COKE IS WORTH SOMETHING IN THE LONE STAR STATE.—Mr. O. L. Musgrave, Supt. of the San Antonio (Texas) Gas Light Company, is on an Eastern visit, partly for pleasure, but chiefly for the purpose of inquiring into anything new in the line of retort house benchwork. We understand that he has determined to put in two benches of nines on the Klonne and Bredel plan, and that the San “Antone” gas men ought to have done something of the kind at an earlier period will be understood from the fact that coke, in the retort house yard, readily commands 25 cents a bushel. Indian Territory coal is carbonized, which costs, placed in the Company's bins, \$7.50 per ton. Tar is also valuable in that city, and we opine the local gas men are pretty firm believers in the value of coal gas. English cannel—it comes to Galveston in the shape of ballast in English bottoms—is used as an enricher. The annual sendout of the Company is pretty close on to twenty millions cubic feet, and the selling prices range between a maximum of \$3.50 and a minimum of \$2.80.

STREET LIGHTING AT NEWBURGH, N. Y.—At a recent meeting of the Newburgh Council the local gas suppliers were awarded a contract for the partial lighting of the city by gas, both as to the streets and public buildings, on the terms which prevailed last year. These were, street lamps, \$35 each per annum; gas to public buildings, \$2.50 per thousand.

MORIBUND.—The Gas Reform Association of this city did not long survive the demise of its originator—the late Mr. Sherwood—for some days

ago Judge Donohue appointed Jacob Marks receiver of the property of the “reformers,” the action being taken at the instance of J. J. Bradley, to whom the “reformers” were indebted in the sum of \$4,827. Mr. Bradley got judgment for that amount, but that is about all he did get. These are the worthies who canted so glibly about the dishonesty of the managers of the Consolidated Gas Light Company; but it is just what one might expect—they prate about virtue, and fail to pay their bills.

SORRY TO KNOW THAT HE GOES SO FAR FROM US.—We have information to the effect that Mr. Edward G. Pratt, Secretary of the Guild of Gas Managers, and Supt. of the North Attleboro' (Mass.) Gas Light Company, at a special meeting of the directors, held April 22d, tendered his resignation, the same to take effect on May 15th. Mr. Pratt has been retained to take charge of the Des Moines (Iowa) Company's plant. Of course, this means more responsibility and a better salary, but we are sorry to think that his new berth will take him so far away from us. However, if North Attleboro' is sad, Des Moines, it may be said, does not share in the feeling. We wish him the best of good luck in his new field.

INCORPORATED.—The Chicago Arc Light and Power Company was incorporated on the 23d of April. It is capitalized in \$1,000,000. Among the incorporators are Messrs. C. R. Cummings, Marshall Field, S. A. Kent, C. N. Fay and Jno. H. Barker.

COL. BENSON'S EUROPEAN STUDIES.—A correspondent who keeps a watchful eye over current happenings forwards the following: “Col. Fred. S. Benson, Engineer of the Nassau Gas Light Company, of Brooklyn, N. Y., made good use of the time devoted to his recent European trip. He visited five countries, and inspected a large number of gas works. Almost every hour of the daytime was thus employed, his traveling being mainly done at night. In fact the rapidity of his movements excited the admiration and wonder of the British and Continental gas managers, who are apt to punctuate their journeyings by longer and more frequent stops. With his usual good fortune he succeeded in securing as a traveling companion one of the most intelligent and influential members of the European fraternity, hence the Colonel was made as much at home in the French, German and Austrian works as when in England and Scotland. The fruit of his observations will not only be reaped by his Company, but, later on, the Society of Gas Lighting and the American Association will doubtless be edified by papers from his ready pen. Col. Benson made especial study of the various systems of regenerative and recuperative furnaces, and the result will be seen ere long in a model installation at the Nassau works. Among other approved apparatus in use extensively abroad, as well as in this country, of course, is the ‘Standard’ Washer-Scrubber, and one of these, with a daily capacity of one million cubic feet, has been ordered from the Smith & Sayre Manufacturing Company for erection in the Nassau works.”

Correspondence

[The JOURNAL is not responsible for the opinions expressed by correspondents.]

Public Lighting in Brooklyn, N. Y.

BOSTON, MASS., April 22, 1887.

To the Editor AMERICAN GAS LIGHT JOURNAL:

While in New York, a few days since, I saw a statement in one of the Brooklyn (N. Y.) newspapers relative to the cost of the electric light, and, not understanding the statement, I wrote to one of our friends there and obtained from him the following facts, which differ somewhat from the statement put forth by the author of the figures in the Brooklyn newspaper.

The present price received by the Brooklyn Gas Company is \$19.80 per year per light, or the same price that this Company has been paid for the past four years. Four of the other companies receive \$22 per year, and one company receives \$21.75 per year.

The electric light was first introduced in Brooklyn, for street lighting, in June, 1885; and since that date 4,844 gas lights, which formerly cost the city \$103,578.85, have been discontinued. To replace these gas lights 995 electric lights are used, which cost \$181,582 per annum—showing an increase in cost of lighting of \$77,903.15. Instead, therefore, of the false statement put forth before the Committee of the Legislature by interested parties, the truth seems to be that if all the gas lights in Brooklyn were to be displaced by electric lights, the cost would be increased over \$233,000.

Verily, it does seem as though there are those engaged in electric lighting who are as good at fancy figures as some of those who seek to introduce the latest patent gas processes.

NAMSAG.



A. M. CALLENDER & CO.,
PROPRIETORS.

Editor—JOS. R. THOMAS, C.E.
Asst. Editor—T. J. CUNNINGHAM.
Manager—C. E. SANDERSON.

PUBLISHED ON THE 2ND AND 16TH OF EACH MONTH
At No. 42 Pine Street, New York.

This is a recognized official organ of—
LIGHT, HEAT, STEAM, WATER-SUPPLY,
VENTILATION, SANITARY IMPROVEMENT,
AND GENERAL SCIENCE.

TERMS

Subscription—Three Dollars per annum, in advance.

AGENTS

NEW YORK—AMERICAN NEWS Co. 39 and 41 Chambers St.
BOSTON—S. M. PETTENGILL & Co., 6 State Street.
PHILADELPHIA—PRATT & Co., Corner 9th and Arch Streets.
England—C. W. HASTINGS, 22 Buckingham St., London, W C
Germany—B. WESTERMANN & Co., of New York

MONDAY, MAY 2, 1887.

The Market for Gas Securities.

The market for city shares keeps dull and strong, although some animation has been developed in Consolidated dealings. However, there is nothing as yet in the line of regularity in the volume of business transacted, and brokers assert that until the Legislature adjourns the see-saw style is apt to prevail. Consolidated touched 86½ a few days ago, but the greater number of sales took place at, or slightly below, 86. The Standard Company acts, of course, as a disturbing factor, nevertheless those especially interested in old city gas shares do not appear to regard the future influence of the newcomers on the gas supply of the metropolis as being particularly dangerous. The prophets are once more turning their attention to the probability of an increase in the rate of dividend on Consolidated stock, but the Irving Place magnates manage to conceal their intentions in that regard as carefully as ever. If the dividend is not increased next declaration day (and we think it unlikely), the Company ought to carry over a handsome surplus. Perhaps the safest way to deal with the Brooklyn situation would be to pass it silently for the present; but the figures there are well maintained. In out-of-town shares the feature was the advance in Baltimore securities, Consolidated having sold, on April 25, up to 76½, or a gain of ten points over our last quotation. Our quotation for April 28 (time of writing) is 73½. The cause of the rise is attributed to free buying for control by Mr. Garrett, who possesses a large interest (so it is said) in the Chesapeake Company. The latter stock also scored an advance of ten points. We are unable to give information in regard to the Chicago situation, but presume that matters there will speedily take shape. Private advices state that Laclede, of St. Louis, is bid for at 129.

San Francisco shares are higher. In fact the out-of-town situation, as a rule, is all on the side of the holder.

Gas Stocks.

Quotations by Geo. W. Close, Broker and Dealer in Gas Stocks.

16 WALL ST., NEW YORK CITY.

MAY 2.

All communications will receive particular attention.
The following quotations are based on the par value of \$100 per share.

	Capital.	Par.	Bid	Asked
Consolidated.....	\$35,430,000	100	85½	86½
Central.....	440,000	50	30	—
“ Scrip.....	220,000	—	47	57
Equitable.....	2,000,000	100	127	130
“ Bonds.....	1,000,000	—	113	115
Harlem, Bonds.....	170,000	—	—	—
Metropolitan, Bonds....	658,000	—	110	113
Mutual.....	3,500,000	100	100	101
“ Bonds.....	1,500,000	1000	101	—
Municipal, Bonds.....	750,000	—	—	—
Northern.....	125,000	50	30	—
“ Scrip.....	108,000	—	—	—
Yonkers.....	—	50	—	80
Richmond Co., S. I.....	300,000	50	50	—
“ Bonds.....	12,000	—	—	—
Gas Co's of Brooklyn.				
Brooklyn.....	2,000,000	25	105	107
Citizens.....	1,200,000	20	56	58
“ S. F. Bonds....	320,000	1000	—	103
Fulton Municipal.....	3,000,000	100	135	—
“ Bonds....	300,000	—	—	106
Peoples.....	1,000,000	10	58	60
“ Bonds.....	290,000	—	100	—
“ “.....	250,000	—	100	—
Metropolitan.....	1,000,000	100	82	84
Nassau.....	1,000,000	25	104	106
“ Ctfs.....	700,000	1000	100	—
Williamsburgh.....	1,000,000	50	130	—
“ Bonds... ..	1,000,000	—	111	—
Out of Town Gas Companies.				
Boston (Mass.) Gas Co.	2,500,000	500	910	—
Buffalo Mutual, N. Y... ..	750,000	100	90	95
“ Bonds... ..	200,000	1000	95	100
Citizens, Newark... ..	1,000,000	50	140	145
“ “ Bonds.	45,000	—	—	—
Chicago Gas Co., Ills... ..	5,000,000	25	142	145
Peoples G. L. & C. Co.,				
Chicago, Ills.....	3,000,000	—	29	31
Cincinnati G. & C. Co..	6,000,000	100	184	185
Consolidated, Balt.....	6,000,000	100	73½	—
“ Bonds....	3,600,000	—	107	107½
Chesapeake, Balt.....	1,500,000	100	89	90
“	1,000,000	—	100	102
Consumers Toronto....	1,000,000	50	194½	196½
Central, S. F., Cal.....	—	—	86	100
Capital, Sacramento, Cal.	—	—	56	58
Hartford, Conn.....	750,000	25	140	142
Jersey City.....	750,000	20	155	—
Laclede, St. Louis, Mo.	1,600,000	100	125	—
Louisville, Ky.....	2,570,000	50	130	132
Little Falls, N. Y.....	50,000	100	95	100
“ Bonds	25,000	—	100	103
Montreal, Canada.....	2,000,000	100	209	215
New Haven, Conn.....	—	25	190	195
Oakland, Cal.....	—	—	36½	—
Peoples, Jersey City... ..	—	—	25	30
“ “ Bonds..	—	—	—	—
Paterson, N. J.....	—	25	90	—
Rochester, N. Y.....	—	50	75	80
St. Louis, Missouri.....	600,000	50	—	—
San Francisco Gas Co.				
San Francisco, Cal... ..	10,000,000	100	61	62
Memphis (Tenn.) Gas... ..	750,000	100	—	—
“ Bonds.	240,000	100	103	—
Washington, D. C.....	2,000,000	20	210	—
Wilmington, Del.....	—	50	205	215
Havana (Cuba) Gas Co.	3,000,000	100	18	20
“ Bonds....	550,000	—	102	—

Advertisers Index.

	Page
GAS ENGINEERS.	
Jos. R. Thomas, New York City.....	300
Wm. Henry White, New York City.....	300
Wm. Farmer, New York City.....	300
William Gardner, Pittsburgh, Pa.....	300
GAS WORKS APPARATUS AND CONSTRUCTION.	
James R. Floyd, New York City.....	303
T. F. Rowland, Greenpoint, L. I.....	303
Delly & Fowler, Phila., Pa.....	308
Kerr Murray Mfg. Co., Fort Wayne, Ind.....	302
Stacey Mfg. Co., Cincinnati, Ohio.....	303
Bartlett, Hayward & Co., Baltimore, Md.....	303
Morris, Tasker & Co., Limited, Phila., Pa.....	302
Davis & Farnum Mfg. Co., Waltham, Mass.....	292
R. D. Wood & Co., Phila., Pa.....	302
Southwark Foundry and Machine Co., Philadelphia, Pa.....	302
Bouton Foundry Co., Chicago, Ills.....	303
PROCESSES.	
National Gas Light and Fuel Co., Chicago, Ills.....	293
GAS AND WATER PIPES.	
Gloucester Iron Works, Phila., Pa.....	300
Mellert Foundry and Machine Co., Reading, Pa.....	300
Cincinnati and Newport Iron and Pipe Co., Newport, Ky.....	300
Ohio Pipe Co., Columbus, Ohio.....	300
Pancoast & Rogers, New York City.....	300
M. J. Drummond, New York City.....	300
Wells Rustless Iron Co., New York City.....	292
GAS ENGINES.	
Schleicher, Schumm & Co., Phila., Pa.....	276
Clerk Gas Engine Co., Phila., Pa.....	292
RETORTS AND FIRE BRICK.	
J. H. Gautier & Co., Jersey City, N. J.....	98
B. Kreisler & Sons, New York City.....	298
Adam Weber, New York City.....	298
Laclede Fire Brick Works, St. Louis, Mo.....	298
Brooklyn Retort and Fire Brick Works, Brooklyn, N. Y.....	298
Borgner & O'Brien, Phila., Pa.....	298
James Gardner, Jr., Pittsburgh, Pa.....	298
Henry Maurer & Son, New York City.....	298
Chicago Retort and Fire Brick Works, Chicago, Ills.....	298
Baltimore Retort and Fire Brick Co., Baltimore.....	298
Oakhill Gas Retort and Fire Brick Co., St. Louis, Mo.....	298
Evens & Howard, St. Louis, Mo.....	299
Cincinnati Gas Retort and Fire Brick Works, Cincinnati, O.....	299
Emil Lenz, New York City.....	299
SCRUBBERS AND CONDENSERS.	
G. Shepard Page, New York City.....	301
REGENERATIVE FURNACES.	
Bartlett, Hayward & Co., Baltimore, Md.....	291
Fred. Bredel, New York City.....	291
GAS GOVERNORS.	
T. C. Hopper, Phila., Pa.....	296
CEMENTS.	
C. L. Gerould, Manchester, N. H.....	298
GAS ENRICHERS.	
Standard Oil Co., Cleveland, Ohio.....	304
GAS METERS.	
Harris, Griffin & Co., Phila., Pa.....	306
American Meter Co., New York and Philadelphia.....	307
The Goodwin Gas Stove and Meter Co., Philadelphia, Pa.....	307
Helme & McIlhenny, Phila., Pa.....	307
D. McDonald & Co. Albany, N. Y.....	307
Nathaniel Tufts, Boston, Mass.....	306
EXHAUSTERS.	
P. H. & F. M. Roots, Connersville, Ind.....	294
Smith & Sayre Manufacturing Co., New York City.....	294
Wilbraham Bros., Philadelphia, Pa.....	294
Connelly & Co., New York City.....	295
GAS COALS.	
Penn Gas Coal Co., Phila., Pa.....	305
Perkins & Co., New York City.....	304
Newburgh Orrel Coal Co., Baltimore Md.....	305
Despard Coal Co., Baltimore, Md.....	305
Chesapeake and Ohio R.R. Coal Agency, N. Y. City.....	305
Westmoreland Coal Company, Phila., Pa.....	305
Monongahela & Peters Creek Gas Coal Co., Pittsburgh, Pa.....	305
CANNEL COALS.	
Perkins & Co., New York City.....	304
J. & W. Wood, New York City.....	304
VALVES.	
Ludlow Valve Manufacturing Co., Troy, N. Y.....	296
John McLean, New York City.....	296
Chapman Valve Manufacturing Co., Boston, Mass.....	296

ENGINES AND BOILERS.	
Jarvis Engineering Co., Boston, Mass.	291
PURIFYING MATERIAL.	
S. H. Douglas, Ann Arbor, Mich.	299
GAS LAMPS.	
The Siemens-Lungren Co., Philadelphia, Pa.	301
G. Shepard Page, New York City.	300
Alho-Carbon Light Co., Newark, N. J.	293
Standard Gas Lamp Co., Phila., Pa.	299
Geo. H. Gregory, New York City.	299
PURIFIER SCREENS.	
John Cahot, New York City	267
Geo. A. Mills, Baltimore, Md	299
GAS STOVES.	
American Meter Co., New York and Philadelphia.	297
The Goodwin Gas Stove and Meter Co., Phila. Pa.	308
STREET LAMPS.	
J. G. Miner, Morrisania, New York City.	260
Bartlett Street Lamp Mfg Co., New York City	296
BURNERS.	
G. Gefroerer, Phila., Pa.	304
STEAM BLOWER FOR BURNING BREASE.	
H. E. Parson, New York City	268
GASHOLDER TANKS.	
W. C. Whyte, New York City	292
GAS FIXTURES.	
Mitchell, Vance & Co., New York City	296
COKE CRUSHER.	
C. M. Keller, Columbus, Ind.	305
B. J. Allen, Newark, New Jersey.	305
COAL HANDLING MACHINERY.	
C. W. Hunt Company, New York City	299
GAS BAGS.	
Peerless Manuf'g Co., New York City	299
BOOKS, ETC.	
English Journal of Gas Lighting	291
Gas as a Source of Light, Heat and Power.	296
Goodwin's Directory of Gas Light Companies	304
The Chemist's Assistant	300
King's Treatise	306
Scientific Books	306
Management of Small Gas Works	300
Newbigging's Gas Manager's Handbook	306
Gas vs. Electricity	292

**GAS WORKS FOR SALE.
A RARE CHANCE.**

The owner will dispose of the controlling interest in a gas works in a growing Western city, on account of declining health and inability to attend to the business. For particulars address
665-6 P. O. Box 825, Appleton, Wis.

ALBO-CARBON FIXTURES FOR SALE.

Three 12-Burner, Two 8-Burner, and Fourteen 6-Burner Clusters.
All in good order, having been used but six months. Will be sold cheap. For particulars communicate with
E. G. PRATT, Supt. N. Attleboro Gas Lt. Co., North Attleboro Mass.

FOR SALE,

Two Sinuous Friction Condensers,
Each 1 ft. 3 in. wide by 11 ft. 3 in. long, and 18 ft. high, of sufficient capacity for 225,000 cu. ft. per day. Apply to
665-12 PETER COFFEY, Supt Gas Co., Peoria, Ill.

JARVIS ENGINEERING CO.,

61 Oliver St., Boston, Mass.

CONTRACTORS FOR ERECTING

COMPLETE STEAM OUTFITS FOR ELECTRIC LIGHTING STATIONS.

Steel Boilers set with Jarvis Pat. Boiler Setting,

To burn **COKE SCREENINGS** for Fuel.

ARMINGTON & SIMS CO. ENGINES,

Belting direct to Dynamos, without using Shafting.

SEND FOR CIRCULARS.

REFERENCES.—Charlestown Gas & Electric Light Co., Charlestown, Mass.; Schenectady Gas & Electric Light Co., Schenectady, N. Y.; Brookline Gas Co., Brookline, Mass.

ENGLISH

"Journal of Gas Lighting."

Issued weekly. New volume commences Jan. 1, 1887. Price, \$7 per annum. Subscriptions taken by

CHARLES NETTLETON, Agent for U. S.
No. 115 BROADWAY, N. Y. CITY.

KLOENNE & BREDEL

IMPROVED REGENERATIVE FURNACES.

Self-Sealing Mouthpieces & Bridge-Pipes, Retort Houses,

WASHER-SCRUBBERS,

Gasholders, and Complete Gas Works.

Refers, by permission, to Mr. Eugene Vanderpool, of Newark, N. J.; Mr. E. G. Cowdery, of Milwaukee, Wis.; and Mr. Theo. Forstall, of Chicago, Ill. For further information apply to

FRED. BREDEL, 332 East 17th St., N. Y. City.

MUNICH REGENERATIVE FURNACE

System Drs. Schilling and Bunte.

Greatest Durability! Minimum of Attention!

COMPLETE DISTILLATION IN 3½ HOURS.

Ten to Thirteen Pounds of Coke to Hundredweight of Coal.

NO CLINKER. NO CARBONIC OXIDE IN THE REGENERATIVE FLUES.

Almost Automatic in Action.

The Most Successful Regenerative Furnace in Use.

BARTLETT, HAYWARD & CO.

Agents for the United States.

**Superintendent's Position
Desired,**

By a young man of several years experience in the manufacture and distribution of coal gas. Best of references given.
669-2 Address "P. B.," care this Office.

Superintendent's Position Desired

By a practical man of twenty-five years' experience in the manufacture and distribution of coal and water gas. Satisfactory references given. Address
646-1f "ENGINEER," care this Office.

FOR SALE,

Ten No. 2 Siemens Regenerative Gas Lamps,

With Factory Fixtures and Reflectors complete and in order. Only used three or four months. Will be sold cheap.

DANVILLE NAIL AND MFG. CO.,

Danville, Pa.

To All Whom It May Concern!

The SIEMENS-LUNGREN COMPANY hereby warns the public against the use of various infringing Regenerative Gas Lamps which are offered for sale. This Company has heretofore delayed bringing suit to enjoin the manufacture or importation of such infringing lamps, solely because of the practical worthlessness of the infringing devices; and although, in each instance, they infringe some one or more of the various patents owned or controlled by this Company, they have fallen into disuse sooner than any suit could be brought to a hearing. As, however, the introduction of these infringing lamps has tended to discredit the practicability of our Company's system of regenerative gas lighting, we have instructed our Attorneys, Messrs. Geo. Harding, C. S. Whitman, and Silas W. Pettit, to give notice that legal proceedings will in future be taken against all such infringers.

THE SIEMENS-LUNGREN CO., 21st St. & Washington Av., Phila., Pa.

GAS ENGINES.

GAS WORKS APPARATUS AND CONSTRUCTION.

THE CLERK GAS ENGINE CO.,

Main Office, 1012, 1014, 1016, 1018 Filbert St., Philadelphia, Pa.

WM. W. GOODWIN, Prest.

E. STEIN, Sec.

S. LEWIS JONES, Asst. Sec.

A. J. DOTY, Supt.

The utility and convenience of the Gas Engine being no longer an open question, it only remains now for intending purchasers to select the BEST. We claim for the CLERK GAS ENGINE that it is equal to any other manufactured as regards steadiness in running, simplicity, and ease of keeping in repair, and that it gives the greatest amount of power for the least money (both in first cost and expense of running) of any engine made. In support of this claim we refer to the test of the Gas Engines made under the direction of the American Institute of New York, in December, 1885, and heretofore published in these columns. These engines are especially adapted for continuous running under heavy loads, and we can refer to Engines which have run 22 hours a day for months at a time.

Made in Sizes of 5, 10, 15, 20, and 25 Horse Power. All Engines Guaranteed for One Year.

"RUSTLESS" IRON WATER PIPE.

RUSTLESS

Send for New Catalogue.

RUSTLESS

The WELLS RUSTLESS IRON COMPANY,
Nos. 7 and 9 Cliff Street, New York City.

GASHOLDER TANK CONSTRUCTION, ETC.

Gas Companies and others about to erect Gasholders will find it profitable to consult W. C. WHYTE, who for over thirty years has made a specialty of

Holder Tank Excavation and Mason Work.

Fifty tanks now in operation show the sort of work done. Address

W. C. WHYTE, No. 15 Cortlandt St., N. Y. City.

GAS vs. ELECTRIC LIGHT.

We would invite attention to the able and exhaustive argument of General A. Hickenlooper, President of the Cincinnati Gas Light and Coke Company, contained in a handsome pamphlet of 96 pages, entitled

"EDISON'S INCANDESCENT ELECTRIC LIGHTS FOR STREET ILLUMINATION. REPORT OF AN ARGUMENT DELIVERED BY A. HICKENLOOPER BEFORE THE COMMITTEE ON LIGHT, MUNICIPAL COUNCIL, CITY OF CINCINNATI, JULY 22, 1886."

This is a subject of special interest to all Gas Light Companies.

Prices.

25 copies.....	\$7.50	100 copies.....	\$22.50
50 copies.....	12.50	250 copies.....	50.00

A sample copy will be sent by mail on receipt of 50 cts.
A. M. CALLENDER, & CO., 42 PINE ST., N. Y. CITY.

F. J. DAVIS & J. R. FARNUM,

TRUSTEES AND AGENTS FOR THE

SINUOUS FRICTION CONDENSER.

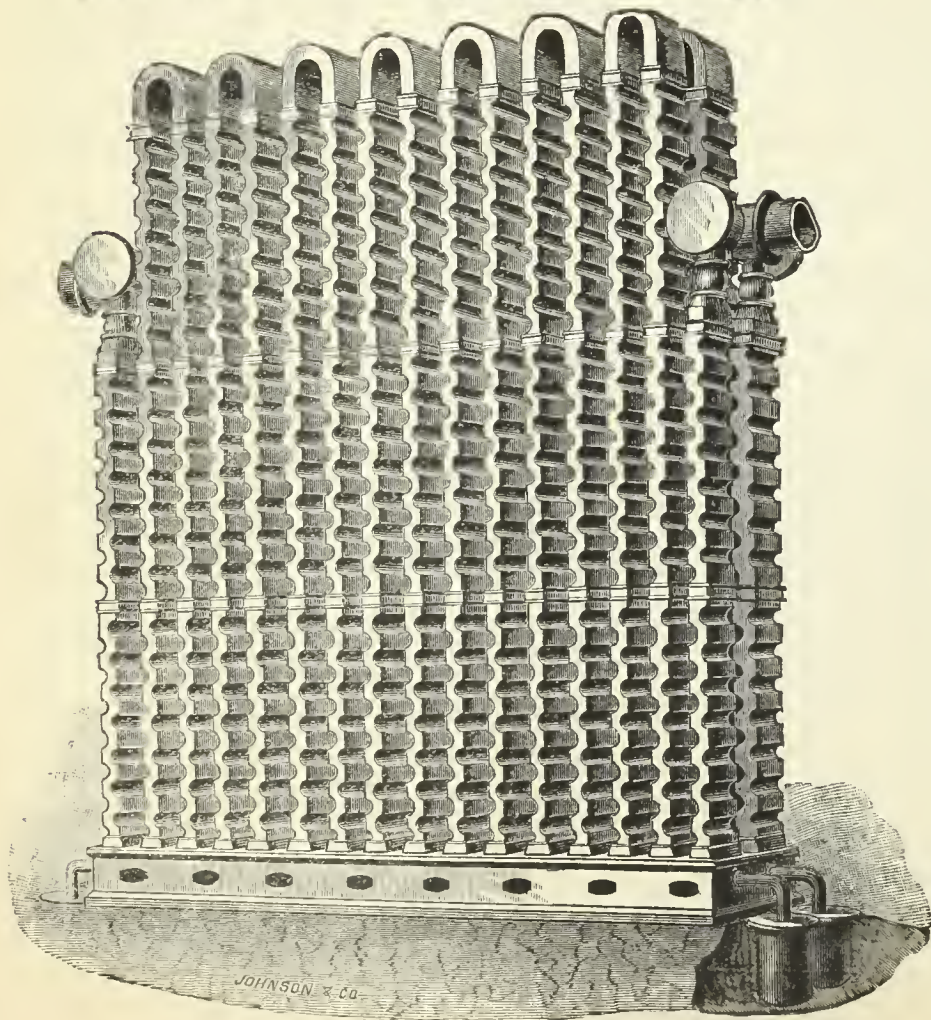

We desire to draw the attention of the gas community to the merits of the SINUOUS FRICTION CONDENSER. Companies intending to introduce new condensers into their works will do well to confer with us and examine plans and estimates before contracting for any other pattern. The FRICTION CONDENSER is now in use at the gas works located in the following places:

Portland, Me.	Brookline, Mass.	Pawtucket, R. I.	Frederickton, N. B.
Newport, R. I.	Chelsea, Mass.	Jamaica Plain, Mass.	St. John, N. B.
Gloucester, Mass.	Woburn, Mass.	Attleboro, Mass.	Paterson, N. J.
Newton & Water- town, Mass.	Peoria, Ill.	Calais, Me.	Dover, N. H.
	Clinton, Mass.	Fall River, Mass.	Waltham, Mass.
		Nassau Works, Brooklyn, N. Y.	

DAVIS & FARNUM MFG. CO.

MANUFACTURERS OF

Gas and Water Pipes,

AND

GAS AND WATER MACHINERY

OF THE MOST APPROVED PATTERN.

Also, Gasholders and Iron Roofing.

Orders from Gas and Water Companies promptly attended to.

WALTHAM, MASS.

Boston Office, Room 55, Mason Building, 70 Kilby Street.

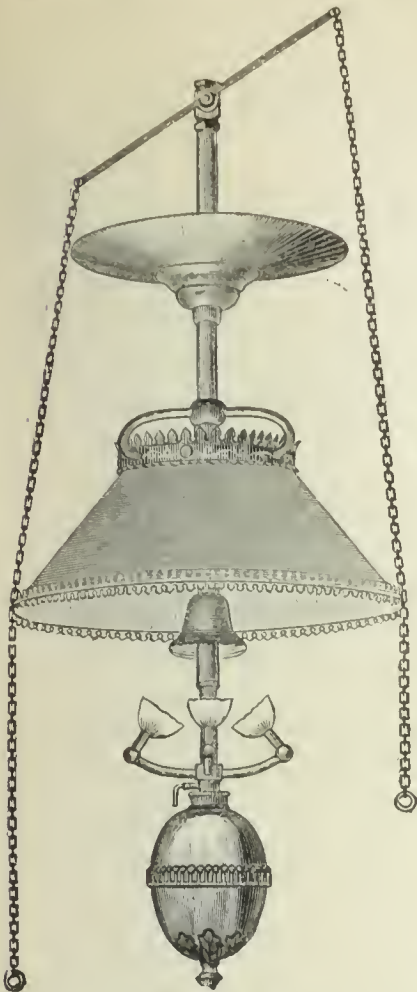

THE ALBO-CARBON LIGHT!

The Perfection of Gas Lighting.

Producing the Highest Illumination yet obtained from Gas, and
EFFECTING A SAVING IN ITS CONSUMPTION.

It has been most effective in

Replacing Electricity,

AFFORDING A

SOFT WHITE LIGHT
 of **EXTREME BRILLIANCY & POWER.**

It has been most successful in

Supplanting Kerosene,

Giving Increased Light, Less Heat, and Perfect Safety
WITHOUT ADDITIONAL COST.

NOTICE.—Suits are pending in the United States Circuit Courts in Illinois and Pennsylvania against various parties for infringement of our Letters Patent No. 247,925, dated October 4, 1881, and No. 333,862, dated January 5, 1886. The first of these suits has come up for hearing, and an injunction has been granted therein. The second of said suits has not yet been reached for hearing. All persons are cautioned against manufacturing, selling, or using any apparatus or material which infringes our Patents. We intend to prosecute all parties infringing patents owned by us.

THE ALBO-CARBON LIGHT COMPANY, - - - NEWARK, N. J.,
 Sole Manufacturers for the United States.

DURING THE PAST YEAR, THE

NATIONAL GAS LIGHT AND FUEL CO.

218 LA SALLE ST., CHICAGO,

Have Erected Twelve Sets of Water Gas Generating Apparatus under the
Springer Cupola System. They are as follows:

- Newton Illuminating Company, Newton, Kansas.— Daily capacity, 120,000 cu. ft.
- Wellington Light & Heat Co., Wellington, Kansas.— Daily capacity, 120,000 cu. ft.
- Chippewa Falls, Gas Light Co., Chippewa Falls, Wis.— Daily capacity, 120,000 cu. ft.
- Elkhart Gas Light & Coke Co., Elkhart, Indiana.— Daily capacity, 120,000 cu. ft.
- Madison City Gas Light Company, Madison, Wis.— Daily capacity, 120,000 cu. ft.
- South Bend Gas Light Co., South Bend, Indiana.— Daily capacity, 250,000 cu. ft.
- Sheboygan National Gas Comp'y, Sheboygan, Wis.— Daily capacity, 120,000 cu. ft.
- Salina Gas Light Company, Salina, Kansas.— Daily capacity, 120,000 cu. ft.
- Rathbun Company, Deseronto, Province Ontario.— Daily capacity, 80,000 cu. ft.
- Jefferson City Gas Light Co., Jefferson City, Mo.— Daily capacity, 120,000 cu. ft.
- Mankato Gas Light Company, Mankato, Minnesota.— Daily capacity, 80,000 cu. ft.
- Minneapolis Gas Lt. & Coke Co., Minneapolis, Minn.— Daily capacity, 1,000,000 cu. ft.

1886

1886

EXHAUSTERS.

EXHAUSTERS.

EXHAUSTERS.

THE ROOTS GAS EXHAUSTER.

CINCINNATI, OHIO, March 24, 1887.

P. H. & F. M. Roots, Connersville, Ind.: Gentlemen—I have the honor to say that after the continuous and uninterrupted use of your Exhausters for a period of fifteen years, it affords me pleasure to endorse them in the highest possible terms.

Very respectfully,

A. HICKENLOOPER, Prest. Cincinnati Gas Co.

CINCINNATI GAS LIGHT AND COKE CO., Cincinnati, Ohio, two No. 6 Gas Exhausters, with Engine, for their new works, which, with the two No. 6 Exhausters, without Engines, at their old works, and one No. 3, with Engine for pumping, for their station at Carthage, make five Exhausters in all for this Company.

CHICAGO, ILL., March 24, 1887.

Messrs. P. H. & F. M. Roots, Connersville, Ind.: Dear Sirs—We have two of your No. 6 Exhausters at our works, which have been running for several months, and are giving very good satisfaction. Yours truly,

THEO. FORSTALL, Prest.

THE CHICAGO GAS LIGHT AND COKE CO., Chicago, Ill., two No. 6 Gas Exhausters and Engine combined on same bed-plate.

St. LOUIS, Mo., March 21, 1887.

Messrs. P. H. & F. M. Roots, Connersville, Ind.: Dear Sirs—In 1872 one of your No. 5 Exhausters was placed in these works, and worked satisfactorily. March, 1885, it was replaced by one of your No. 6 Exhausters. The latter has been in almost constant use the past two years, has worked up to all my expectations, and is to-day in apparently as good condition as when first set up. It has not cost one cent for repairs in all that time. I have also had one of your No. 1 Exhausters, with Engine on same bed-

plate, fitted with your valves and Huntoon Governor, placed in a small works under my control, and in its operation it seems as near perfection as I ever expect an Exhauster to become. Without in the least disparaging Exhausters of other makes, I may say that your Exhauster may be safely recommended as unsurpassed by any other, to those requiring such machines.

Yours respectfully,

FREDERIC EGNER, Eng. and Supt.

CLEVELAND, OHIO, March 22, 1887.

Messrs. P. H. & F. M. Roots, Connersville, Ind.: Gentlemen—Concerning the Exhauster furnished this Company by you last fall, I can say but little—indeed, much need not be said. It simply does its work perfectly, and in a way that inspires confidence that it will not shirk its duty when one's back is turned. If I wanted another 1,000,000 capacity I should try and duplicate our No. 4. Very respectfully,

EDWARD LINDSLEY, Eng. and Supt.

PEOPLES GAS LIGHT CO., Cleveland, Ohio, one No. 4 Exhauster and Engine combined on same bed-plate, Pipe Fittings, Gas and Bye-Pass Valves, Governor, etc.

INDIANAPOLIS, IND., March 21, 1887.

P. H. & F. M. Roots, Connersville, Ind.: Gentlemen—The No. 4 Exhauster and Engine which you erected for us last summer has done all you claimed for it, and has given us perfect satisfaction. Yours very truly,

JAS. SOMERVILLE, Eng. and Supt.

INDIANAPOLIS GAS LIGHT CO., Indianapolis, Ind., one No. 4 Gas Exhauster and Engine combined on same bed-plate, Pipe Fittings, Gas and Bye-Pass Valves, etc. This Exhauster has a capacity of 1,000,000 cu. ft.

P. H. & F. M. ROOTS, Patentees and Manufacturers, **CONNERSVILLE, IND.**

S. S. TOWNSEND, Gen. Agt., 22 Cortlandt St., N. Y.

COOKE & CO., Selling Agts., 22 Cortlandt St., N. Y.

SMITH & SAYRE MFG. COMPANY,

G. PORTER, Prest.

245 Broadway, N. Y.

CHAS. W. ISBELL, Sec'y.

Machinery & Apparatus for Gas Works

Drawings, Plans, and Estimates Furnished for the Improvement, Extension, or Alteration of Gas Works, or for the Construction of New Works.

Mackenzie's Patent Rotary and Steam Jet Gas Exhausters, Governors, Compensators, Condensers, Washers, Scrubbers. Isbell's Patent Automatic Street Pressure Governor, Gas and Water Valves, Hydraulic Main Dip Regulator, Bench Castings, etc. Purifying Boxes and "Standard" Scrubbers. Isbell's Patent Self-Sealing Retort Doors.

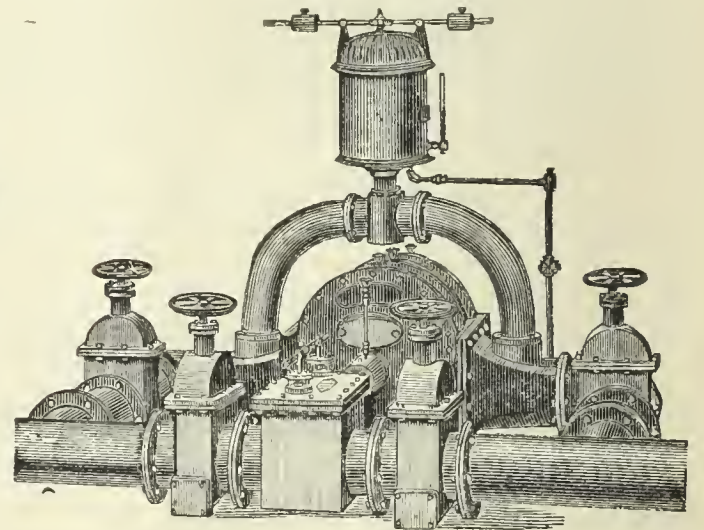

The Wilbraham Gas Exhauster,

"BAKER SYSTEM,"

WITH ENGINE ATTACHED, ON SAME BED PLATE OR WITHOUT.

Best, Cheapest and Most Durable Exhauster known.

WILBRAHAM BROS.,

No. 2320 Frankford Avenue, Philadelphia, Pa.

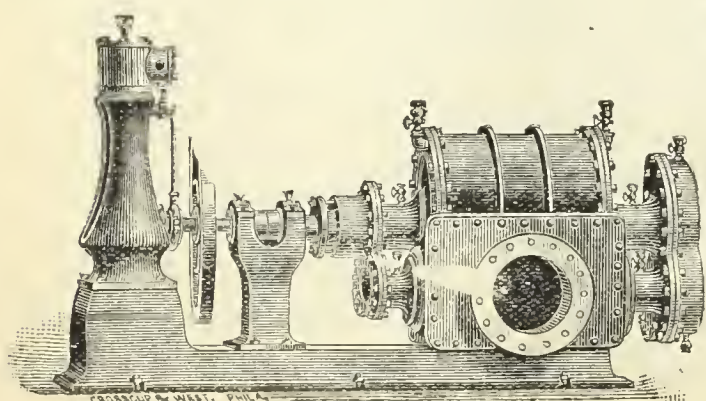

GAS EXHAUSTERS

Have long been regarded as "luxuries" not to be thought of by small companies; but

CONNELLY'S JET EXHAUSTER IS WITHIN THE REACH OF ALL!

Will Pay for Itself in Six Months! Saves Labor! Lengthens the Lives of Retorts! Prevents the Formation of Carbon!
Increases the Yield from Twelve to Fifteen Per Cent.!

We find, after careful inquiry and investigation, that the majority of the Gas Works in the United States and Canada are running *without Exhausters*, which, in our opinion is due to two causes. *First.* The prices heretofore asked for Exhausters have been so high as to counteract, to a great extent, the advantages to be obtained from their use, and caused most managers to postpone their adoption indefinitely, or until their consumption had largely increased. *Second.* Many superintendents have a false impression that it will not pay to run an Exhauster in works producing less than 20,000 feet per day.

The first difficulty we overcome by selling our Exhausters at *extremely low prices*, as will readily be admitted after comparing our list with those of other manufacturers; and as to the second, we can say we have most convincing evidence from many companies operating our Exhausters that they can be used to advantage in works producing *as low as 6,000 cubic feet per day*.

In our improved Exhauster we combine the "Exhaust Tube" Gas and Steam Governors, Gas Compensator, and Bye-Pass Valves in the most compact form possible, which is a very great advantage to the machine, besides enabling us to manufacture and sell at the low prices given.

This is the only Exhauster in the market having a "compensator" in addition to the "gas governor"—a most important improvement, as it does away with all possible danger of their ever drawing air, and thus reducing the illuminating power of the gas.

FOR OIL GAS WORKS.

Our Exhausters are especially adapted for the use of Oil Gas Works; and where oil is required to dilute the gas a valve can be adjusted *to take the exact amount of air required*, thus dispensing with air pumps and their attendant labor and annoyance.

POINTS OF SUPERIORITY.

Requires *one-half the floor space* and *one-third less steam* than any other Exhauster in the market of same capacity. *More cheaply and easily connected*, as outside "Bye-Pass Valves" are dispensed with. It is the only Exhauster manufactured having "Compensator" and "Governor" *combined*, the "Compensator" with all other Exhausters being a separate and distinct machine. It is simple in construction, easily adjusted, not liable to get out of order, and *can be operated by ordinary workmen*.

NAPHTHALINE AND STEAM JET EXHAUSTERS.

As many superintendents of Gas Works believe the use of a Steam Jet Exhauster will inevitably cause trouble from *naphthaline* deposits, we recently sent out letters of inquiry to superintendents using our Steam Jet, asking for their experience, and the following replies speak for themselves. That naphthaline deposits are often unjustly attributed to Jet Exhausters is well known by many superintendents. When the cause cannot be determined it seems to be the rule to place the responsibility on the Jet Exhauster, *if they have one*; but if no Exhauster is used *the cause remains a mystery*.

OFFICE LISTOWEL GAS LT. CO., LISTOWEL, CAN., May 29, 1885.

Messrs. Connelly & Co., Ltd.: Gentlemen—The Exhauster purchased from you over three years ago, and now in use, has proven in every way all you claim for it, and has given us great satisfaction. No trouble has arisen from naphthaline.

Yours respectfully, F. W. HAY, Sec.

RICHMOND GAS CO., RICHMOND, KY., June 1, 1885.

Messrs. Connelly & Co., Ltd., 407 Broadway, N. Y.: Gentlemen—I put in your Steam Jet Exhauster last November. I think it a perfect machine, as it requires no attention whatever. Have not had any naphthaline to contend with; it would be very easy to get rid of that substance if I had it.

Yours very truly, J. B. GORDON, Supt.

HAMPTON, VA., June 3, 1885.

Messrs. Connelly & Co., Ltd.: Gents—We have been using your Steam Jet Exhauster for the past 3 years, and have never had any trouble with it whatever, either from naphthaline or any other source.

Yours truly, J. B. H. GOFF.

BRUNSWICK, ME., May 27, 1885.

Messrs. Connelly & Co., Ltd.: Dear Sirs—Your favor of 23d inst. at hand. In answer would say your Exhauster works well with us. We make an oil gas; are not troubled with naphthaline. Very truly yours, B. G. DENNISON, Prest. Brunswick Gas Lt. Co.

WILMINGTON, O., June 15, 1885.

Messrs. Connelly & Co., Ltd.: Dear Sirs—We started your make of six-inch Steam Jet Exhauster March 30, and I am pleased to state, from the time the steam was turned on, it has performed its work to our entire satisfaction. We have never had any other but a Steam Jet Exhauster, and have never been troubled with naphthaline. For many reasons I prefer it to the "rotary," and have no hesitancy in recommending it.

Yours truly, E. W. HAMLIN, Sec. Gas Co.

OFFICE LOGAN GAS LT. & COKE CO., LAGAN, HOCKING CO., O., May 29, 1885.

Connelly & Co., Ltd.: Gentlemen—In answer to yours of 27th we have to say that the Steam Jet Exhauster put in for us by you last fall has been used constantly since, and, up to this time, we have had no trouble with naphthaline. We have heard many gas men say that a Steam Set Exhauster is liable to bring on trouble with naphthaline, and we have had that fear before us; but so far we have escaped, and we trust we may not have any experience with that gas manager's bugbear.

Yours truly,
LOGAN GAS LT. & COKE CO.

OFFICE ATHENS GAS LT. CO., ATHENS, O., May 30, 1885.

Messrs. Connelly & Co., Ltd.: Dear Sirs—We take pleasure in giving you an unqualified endorsement of your Steam Jet Exhauster. It has been in place almost a year; been tested in all seasons and under all conditions; it has always proved true to the work assigned it. We have had no naphthaline deposit, nor any trouble chargeable to the Exhauster. Nothing but good has come from it, and great good at that. We can't do without it.

Very truly yours, C. H. WELCH, Supt.

OFFICE MEADVILLE GAS WORKS, MEADVILLE, PA., May 29, 1885.

Connelly & Co., Ltd.: Gents—Yours of the 27th received and contents noted. Would say that after using your Steam Jet Exhauster for the past 18 months, find it perfectly satisfactory in every way. So far as naphthaline is concerned, we have had no trouble whatever as yet.

Yours, GEO. S. CULLUM, Supt.

NYACK AND WARREN GAS LT. CO., NYACK, N. Y., May 25, 1885.

Connelly & Co., Ltd.: Gentlemen—Since your Jet Exhauster has been here there has been no trouble, and certainly *no naphthaline*. The only trouble I have experienced was the Jet becoming clogged with tar last week, and I cleaned it in a few minutes. It has run over three years without any trouble or cost for repairs.

Yours truly,
A. MURRAY, Lessee and Manager.

OFFICE CADIZ GAS LT. CO., CADIZ, O., May 29, 1885.

Messrs. Connelly & Co., Ltd.: Gentlemen—Yours of 23d, inquiring how our Steam Jet Exhauster is doing, has been received. We have been using one of your Exhausters about four years, and with the best of satisfaction. We have less trouble with carbon in retorts, make more gas from same amount of coal than before, and have no trouble with stoppage in pipes or trouble from tar; and as regards naphthaline, we are not troubled with it, and do not know what it is to have any stoppage in pipes from naphthaline.

Very truly yours, A. N. HAMMOND, Sec.

SIDNEY (OHIO) GAS WORKS, June 1, 1885.

Connelly & Co., Ltd.: Gentlemen—We have now been using one of your Steam Jet Exhausters about five months, and thus far it has given us perfect satisfaction. We get a better yield and a more brilliant quality of gas from the coal. We have seen in papers and heard from different individuals that Steam Jet Exhausters were productive of naphthaline. "We can't see it," as we have found no trace of it in the works, mains, services, or meters.

Respectfully yours, W. W. GRAHAM, Supt.

CONNELLY & CO., LTD., No. 177 Broadway, New York City.



CHAPMAN VALVE MANUFACTURING CO.,

MANUFACTURERS OF

Valves and Gates for Gas, Ammonia, Water, Etc.

Also, Gate Fire Hydrants With and Without Independent Nozzle Valve. All Work Guaranteed.

WORKS & GEN'L OFFICE: Indian Orchard, Mass. TREASURER'S OFFICE: 72 Kilby & 112 Milk Sts, Boston, Mass.

LUDLOW VALVE MFG. CO.

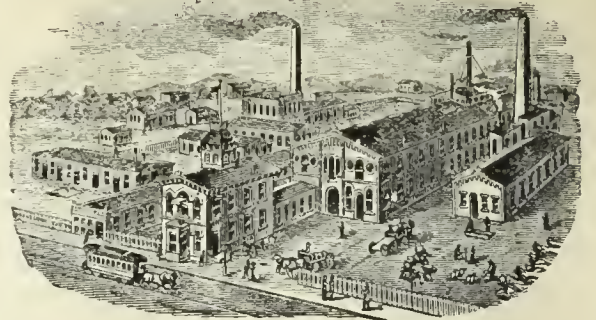

OFFICE AND WORKS, 938 to 954 River Street and 67 to 83 Vail Av. TROY, N. Y.

**T. C. HOPPER'S
AUTOMATIC DIFFERENTIAL GAS GOVERNOR**

Is now in Practical Operation, doing Perfect Automatic Service with Great Precision.

This Governor will do all and more than any other Governor on the Market.

BE SURE TO THOROUGHLY INVESTIGATE THE SUPERIOR MERITS OF THIS GOVERNOR BEFORE PURCHASING.

For Simplicity and Reliable Work it has no Equal. Correspondence Solicited.

T. C. HOPPER & CO., - - Manufactory, 2227 Wood Street, Phila, Pa.

G. S. COOK, Pres. THOS. DAVENPORT (late Davenport Bros.), Sec. & Treas

**BARTLETT
Street Lamp Mfg. Co.**

MANUFACTURERS OF

Bartlett's Patent

GLOBE LAMPS.

FOR

Streets, Parks, Railroad Stations, Public Buildings, Etc.

LAMP POSTS A SPECIALTY.

Office and Salesroom

40 & 42 College Place, N. Y. City.

Gas Companies and others intending to erect lamps and posts will do well to communicate with us.

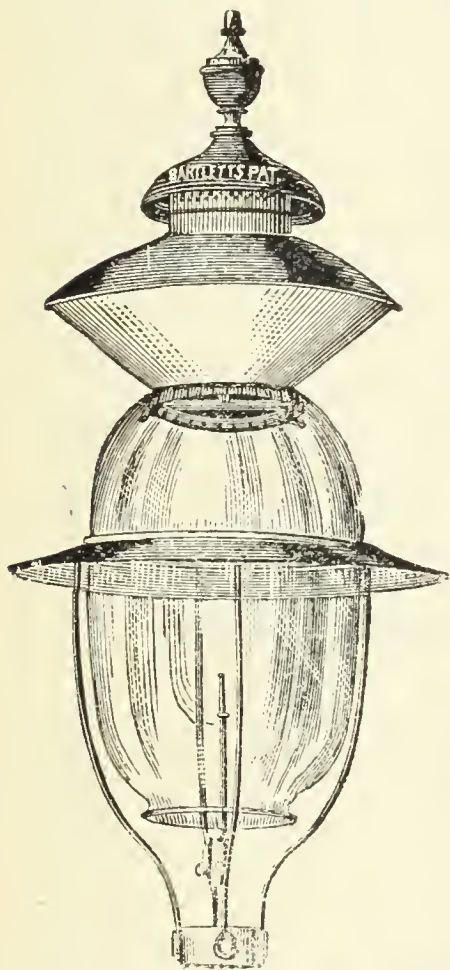

Hydraulic Main Dip Regulators, also Check Valves, Foot Valves, Yard-wash and Fire Hydrants. Send for Circulars.

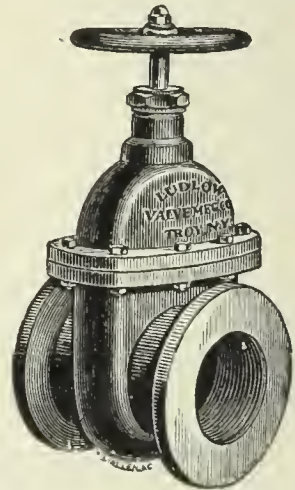

Valves.—Double and Single Gate, 1/2 in. to 48 in., outside and inside Screws. Indicator, etc., for Gas, Water, Steam, and Oil. Send for Circulars.

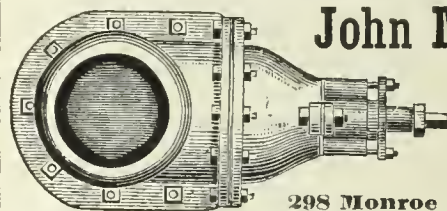

John McLean

Man'furer of

GAS VALVES.

298 Monroe Street, N. Y.

MITCHELL, VANCE & CO.,

MANUFACTURERS OF

Chandeliers

and every description of

GAS FIXTURES.

Also manufacturers of Fine Gilt Bronzes and Marble Clocks, warranted best time-keepers. Mantel Ornaments, etc.

Salesrooms, 836 Broadway, N. Y.

Special Designs furnished for Gas Fixtures for Churches, Public Halls, Lodges, etc.

GAS AS A SOURCE OF LIGHT, HEAT, AND POWER.

By C. J. R. HUMPHREYS

A Pamphlet of twenty-nine pages, treating of the use of Gas as a source of Light, Heat, and Power.

DESIGNED FOR DISTRIBUTION BY GAS COMPANIES AMONG THEIR CUSTOMERS AND OTHERS.

Price, 10 cents each, \$5 per 100, \$50 per 1,000.

Gas Companies can have their own imprint placed on cover without extra charge. All orders to be sent to

A. M. CALLENDER & CO.,

No. 42 Pine Street, N. Y. City.

GAS STOVES.

GAS STOVES.

GAS STOVES.

THE AMERICAN METER CO.,

MANUFACTORIES,

508 to 514 West Twenty-second St., N. Y.

Arch and Twenty-second St., Phila.

Nos. 244 & 246 North Wells Street, Chicago, Ill.

AGENCIES,

No. 177 Elm Street, Cincinnati, Ohio.

Nos. 122 & 124 Sutter Street, San Francisco Cal

No. 810 North Second Street, St. Louis, Mo.

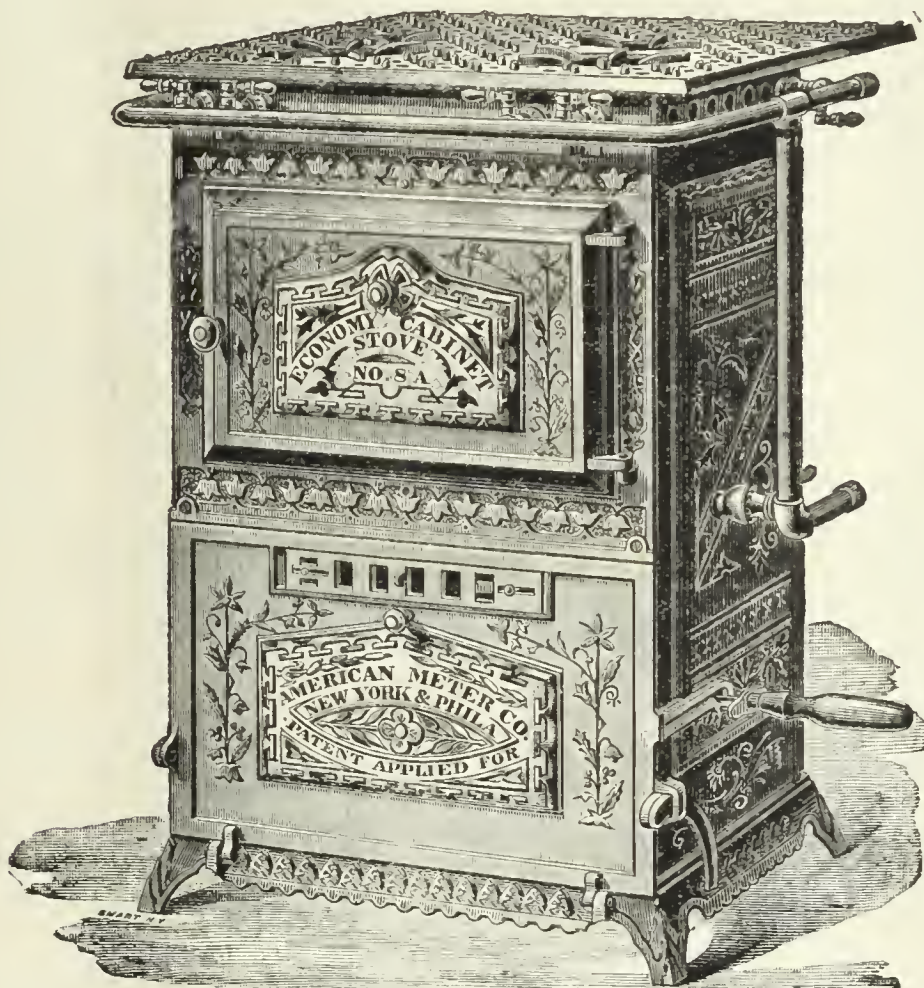

New Design Cast Iron "Economy" Cabinet Stoves.—With Open or Closed Top.

THE COMPANY MANUFACTURES

GAS STOVES FOR COOKING AND HEATING PURPOSES,

In All Sizes, for Domestic, Restaurant, and Hotel Use.

Also,

A Variety of Apparatus for Mechanical Purposes, Using Gas as Fuel.

These Stoves may be seen in operation at our Retail Store, No. 223 Sixth Avenue, N. Y. Call and examine.

SEND FOR ILLUSTRATED CATALOGUE SHOWING THE VARIOUS STYLES AND SIZES.

RETORTS AND FIRE BRICK.

J. H. GAUTIER & CO.,

CORNER OF

GREENE AND ESSEX STREETS,
JERSEY CITY, N. J.

MANUFACTURERS OF

Clay Gas Retorts,
Gas House Tiles,
Fire Bricks, Etc. Etc.Ground Clay, Fire Brick and
Fire Sand in Barrels,J. H. GAUTIER.
C. E. GREGORY.T. B. GAUTIER.
C. E. GAUTIER.**BROOKLYN**

Clay Retort & Fire Brick Works,

(EDWARD D. WHITE & CO.)

Manufacturers of Clay Retorts, Fire Brick,
Gas House and other Tile.VAN DYKE, ELIZABETH, RICHARDS & PARTITION STS.
Office, 88 Van Dyke St., Brooklyn, N. Y.

RETORTS AND FIRE BRICK.

LACLEDE FIRE BRICK MFG. CO.,

MANUFACTURERS OF

Fire Brick, Gas Retorts,

AND

ST. LOUIS STANDARD SEWER PIPE.

Blast Furnace and Cupola Linings, every description of Fire
Clay Material, Fire Clay Flue Linings, Chimney Tops
Dry Milled and Crude Fire Clays, etc.

OFFICE AND DEPOT

901, 903, and 905 Pine Street,
ST. LOUIS, MO.

ESTABLISHED IN 1845.

B. KREISCHER & SONS,

OFFICE FOOT OF HOUSTON ST., E.R., N.Y.

Gas Retorts,

TILES, FIRE BRICK.

AND EVERYTHING IN THE FIRE CLAY LINE.

RETORTS AND FIRE BRICK.

MANHATTAN

FIRE BRICK & ENAMELLED CLAY

RETORT WORKS.

ADAM WEBER.

CLAY GAS RETORTS
AND RETORT SETTINGS
FIRE BRICKS, TILES, ETC.,

Office and Works, 15th Street and Avenue C., N. Y.

Works,
LOCKPORT STATION, PA.

—ESTABLISHED 1864.—

JAMES GARDNER, JR.,

Successor to WILLIAM GARDNER & SON.

Office, Rooms 19 & 20, Lewis Block,
PITTSBURGH, PA. P. O. Box 373.**Fire Clay Goods for Gas Works.**

CHAS. H. SPRAGUE & SON, No. 70 KILBY STREET, BOSTON, MASS., Agents for the New England States.

OFFICE, 418 to 422 East 23d St., New York.

ESTABLISHED 1856.

WORKS, PERTH AMBOY, NEW JERSEY.

HENRY MAURER & SON,
Excelsior Fire Brick & Clay Retort Works
 CLAY GAS RETORTS, BENCH SETTINGS, FIRE BRICK, TILES, ETC.

CHICAGO

Retort & Fire Brick Works,

OFFICE AND FACTORY,
Clark, Forty-Fifth, and La Salle Streets,
CHICAGO, ILL.

GEORGE C. HICKS, PRES. PAUL P. AUSTIN, SEC. & TREAS.

STANDARD

Clay Retorts and Settings.

BLOCKS & TILES

of every Shape and Size to Order.

Standard Fire Bricks.

GEROULD'S IMPROVED RETORT CEMENT.A Cement for patching retorts, putting on mouthpieces, and
making up all bench-work joints. This Cement is mixed ready
for use. Economic and thorough in its work. Fully warranted
to stick. For recommendations and price list addressC. L. GEROULD,
Manchester, N. H.

Western Agent, H. T. GEROULD, Mendota, Ill.

OAKHILL

GAS RETORT & FIRE BRICK

Works.

Proprietors,

PARKER-RUSSELL MINING & MFG. CO.

City Office, 711 Pine Street,

ST. LOUIS, MO.

Our immense establishment is now employed almost entirely in
the manufacture of**MATERIALS FOR GAS COMPANIES.**We have studied and perfected three important points. Our re-
torts are made to stand changes of temperature, the strongest
heats of the furnace, and the abrasion of feeding and emptying.
Our customers are in almost every State of the Union, to all of
whom we refer.

THOS. SMITH, Prest. AUGUST LAMBLA, Vice-Prest. & Sup

BALTIMORE

RETORT & FIRE BRICK CO.

MANUFACTORY AT

LOCUST POINT, BALTIMORE, MD.

Connection with the City by Telephone.

Clay Retorts, Blocks & Tiles,
FIRE BRICK, FIRE CLAY,
AND FIRE CEMENT.Red and Buff Ornamental Tiles and Chim-
ney Tops. Drain and Sewer Pipe (from
2 to 30 inches). Baker Oven Tiles
12 x 12 x 2 and 10 x 10 x 2.WALDO BROS., 88 WATER ST., BOSTON, MASS
Sole Agents the New England States.

RETORTS AND FIRE BRICK.

EVENS & HOWARD,

916 Market St., St. Louis. Mo.
Works, Howard Station, Mo. Pacific R.R.

Fire Brick, Gas Retorts

AND

RETORT SETTINGS.

Sewer Pipe, 3 to 24 in. diameter.

Glass Pot Clay, Ground Fire Clay, in barrels and in bulk. All kinds of Fire Clay Goods.

Cincinnati Gas Retort & Fire Brick Works.

— ESTABLISHED 1872. —

CHAS. TAYLOR,

MANUFACTURER OF

Gas Retorts, Fire Brick, and Tile.

Blast Furnace Linings, Cupola Blocks, Boiler Tiles, Grate Settings, and Stove Linings. Fire Cement, Fire Clay, Fire Sand, and all other Fire Clay Goods.

Branch Works, New Cumberland, W. Va.

GENERAL OFFICE AND WORKS,

Burns St., Cincinnati, Ohio.

Stettiner

Chamotte Fabrik Actien Gesellschaft,

Formerly **DIDIER,**

(Patentees of the Dr. Schilling & Dr. Bunte Regenerative Furnace)

STETTIN, GERMANY.

The attention of all Gas Engineers is called to our Fire-Proof Material, viz.:

CLAY GAS RETORTS

(ENAMELED AND UNENAMELED),

Blocks, Tiles

AND

EXTRA FIRE BRICK,

Pronounced by the highest authorities as superior to and excelling any other similar manufacture. The component of aluminum contained in our material (up to 45 per cent.) is larger than in any other material heretofore sold in the United States; whilst the uniformity of the goods is assured by the most scrupulous analysis of the clay used.

For any further information and prices please apply to

EMIL LENZ,

2 & 4 Stone St., Room 19, N.Y. City.

PATENTS.

FRANKLIN H. HOUGH,

Solicitor of American & Foreign Patents

925 F. ST., WASHINGTON, D. C.

(NEAR U. S. PATENT OFFICE.)

Personal attention given to the preparation and prosecution of applications for Letters Patent. All business before the U. S. Patent Office attended to for moderate fees. **No Agency in the United States possesses superior facilities for obtaining Patents,** or for ascertaining the patentability of inventions. Copies of patents furnished for 25 cents each. Correspondence solicited.

GAS LAMPS.

LIME TRAYS.

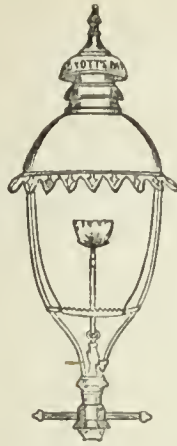

STEPHEN A. MORSE, President.
GODFREY REBMANN, Vice-Pres.

M. B. DYOTT,
Superintendent.

EDWIN F. MORSE, Secretary.
CARLTON M. WILLIAMS, Treas.

STANDARD GAS LAMP CO.,

Office, 411 Cherry St. Factory, 1101, 1103 & 1105 Frankford Av.

Philadelphia, Pa.

It is to the interest of Gas Companies and Cities to use Dyott's Patent Champion Lamps, which give double the light with the same consumption of gas, and will save 50 per cent. over others in cost of keeping in repair. Gas Companies and others intending to erect Lamps of any description will do well to communicate with us. Special Drawings furnished and Estimates given on application upon Architects', Engineers' or our Draughtsmen's Plans.

Our Patent System of Instantaneously Lighting Gas (without electricity) for R. R. Depots is unequalled. Our High Candle Power Burner is superior to the Electric Light or any other High Candle Burner. We manufacture every description of Ornamental Lamps.

WONDERFUL GAS LIGHT!

Great improvements! New inventions! Brilliant success! Brilliant light! Over 500,000 of the Gas Lamps and Burners designed by GEO. H. GREGORY now in practical use. Send for Catalogue. Prices reduced on all goods in order that Gas Companies will introduce the goods to the consumer at a reasonable price. Over one hundred Gas Companies are selling the new lamps and burners. The only way to prevent the adoption of incandescent electric light is to put on the wonderful gas lamps and burners. Address **GEO. H. GREGORY, Gas Lamp and Burner Mnfr., 389 BROADWAY, N. Y.**

Improved Patent
**GAS BAG OR
BLADDER VALVE.**

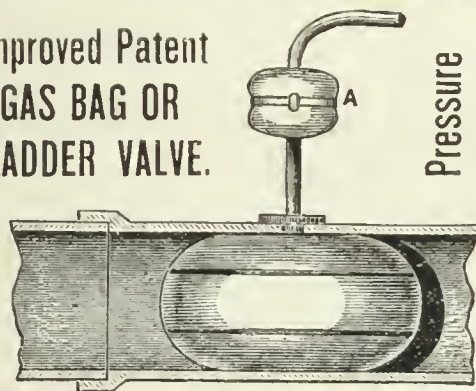

Pressure
Indicator.

MANUFACTURED BY

PEERLESS MFG. CO., 34 Murray St., N.Y.

C. W. HUNT CO.,

No. 111 Broadway, N. Y. City.

MANUFACTURERS OF

Coal Handling Machinery,

AUTOMATIC RAILWAY, HOISTING ELEVATOR,
CABLE RAILWAY, STEAM SHOVEL, HOISTING
ENGINES, COAL TUBS, COAL & COKE CARS.

Plans and Specifications made for the

Erection of Coal Storage Buildings

Send for a Descriptive Pamphlet.

MILLS' REVERSIBLE LIME TRAY,

AND

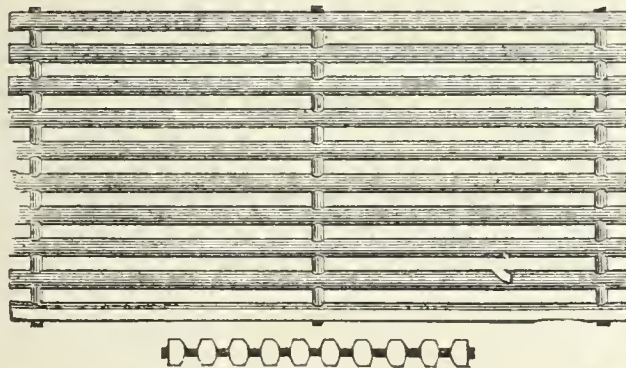

WOODWORK

Of Every Description

NEEDED BY GAS WORKS.

SEND FOR CIRCULAR AND PRICE LIST TO

GEORGE A. MILLS,

Canton Av. & President St., Baltimore, Md.

Ferric Oxide for Gas Purification.

Ferric Oxide, as ground, screened, and prepared by me for purifying purposes, has now been in use for several years by many of the gas works throughout the country, including Detroit, Chicago, Milwaukee, East Saginaw, Burlington (Iowa), Ann Arbor, etc. It has proved, as I believe, the **Most Effective and Economical Agent** now in use. I am prepared to furnish the Oxide by the 100 lbs. or in car load lots, and will be pleased to give price f.o.b. cars at Ann Arbor or at place of destination. Address

S. H. DOUGLAS, Prest. Ann Arbor (Mich.) Gas Light Co.

GAS AND WATER PIPES.

GAS AND WATER PIPES.

ENGINEERS.

SAM'L R. SHIPLEY, Pres.
HENRY B. CHEW, Treas.

JAS. P. MICHELLON, Sec.
WM. SEXTON, Supt.

GLOUCESTER IRON WORKS,
GLOUCESTER CITY, N. J.



Cast Iron Gas & Water Pipes, Stop Valves, Fire Hydrants, Gasholders, &c.
Office No. 6 North Seventh Street, Philadelphia.

MATTHEW ADDY, President.

W. L. DAVIS, Selling Agent.

GEO. P. WILSHIRE, Sec. & Treas.

Cincinnati and Newport Iron and Pipe Company,
NEWPORT, KY.

Lamp Posts
AND
BENCH CASTINGS

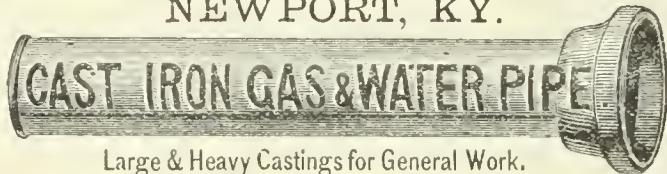

Branch
AND
SPECIAL CASTINGS

A Specialty.

Large & Heavy Castings for General Work.

FOR GAS & WATER CO'S.

Manufacture Pipe from 2 to 48 inches. All work guaranteed first quality.

Pancoast & Rogers.

WROUGHT IRON PIPE,

VALVES AND GATES,

Cast Iron Gas & Water Pipe.

28 Platt and 15 Gold St., New York.

GEO. SHEPARD PAGE,

No. 69 Wall Street, N. Y. City.

REPRESENTING

THE BOWER GAS LAMP.

C. & W. Walker's Carbonic Acid & Tar Extracting Washer

B. DONKIN & CO.'S PAT. IMP. GAS VALVE.

Young & Beilby's Patents. Henry Aitkin's Patents.

R. P. SPICE, London, Eng. HENRY SIMON, Manchester, Eng.

The Management of Small Gas Works.

By C. J. R. HUMPHREYS. Price, \$1.

A. M. CALLENDER & CO., 42 Pine St., N. Y.

P. D. WANNER, Chairman. A. H. MELLERT, Sec. & Treas.
MELLERT FOUNDRY & MACHINE CO., Ltd.
Reading, Pa.

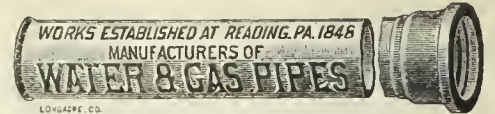

Specials—Flange Pipe, Valves and Hydrants,
Lamp Posts, Retorts, etc.

General Foundry and Machine Work.

JOHN FOX, Selling Agent. 160 Broadway, N. Y.

THE OHIO PIPE COMPANY,

MANUFACTURERS OF

Cast Iron Gas & Water Pipe,

BRANCH AND SPECIAL CASTINGS.

Gas-House Bench Castings, Hydraulics, Lamp Posts, Flange Pipe
and Specials, Architectural Castings, Building Columns,
Joists, Cellar Grates, Sash Weights, etc.

GENERAL FOUNDERS AND MACHINISTS.

Columbus, Ohio.

M. J. DRUMMOND,



SPECIAL CASTINGS AND LAMP POSTS.

Equitable Building, 120 Broadway, N. Y.
Rooms 17 and 18.

JOS. R. THOMAS, C.E.,

May be Consulted on all Mat-
ters Relating to Gas Works
and Gas Manufacture.

ADDRESS THIS OFFICE.

WM. FARMER, ENGINEER,

32 Park Place, Room 36, New York.

THE CHEMIST'S ASSISTANT; OR, KINDERGARTEN SYSTEM OF CHEMISTRY.

A system by which the elements and their valences are represented by illustrations and solid bodies.

BOX AND PAMPHLET COMPLETE, \$2.50.

WM. HENRY WHITE,

CONSULTING AND CONSTRUCTING

Gas Engineer & Contractor

Estimates, Plans, and Specifications furnished for new works or
extensions of existing works.

No. 32 Pine Street, New York City.

Correspondence solicited.

WM. GARDNER,

Gas Engineer,

Lewis Block, Room 20, Pittsburgh, Pa.

Those who intend to make alterations in existing gas plants, or
who contemplate the erection of new works, will find it to their
interest to open correspondence with the above. Plans made
and estimates furnished.

GAS LAMPS.

SCRUBBERS AND CONDENSERS.

The Siemens and Lungren REGENERATIVE GAS LAMPS.

A System of Burning Gas whereby its Illuminating Power is Increased from 300 to 400 per ct. without the Expense, Trouble and Annoyance resulting from the use of Hydrocarbon Enriching Material.

The Siemens-Lungren Company received the only Silver Medal or Highest Award for Gas Burners at the "Novelties" Exhibition of the Franklin Institute, held at Phila., Oct., '85.

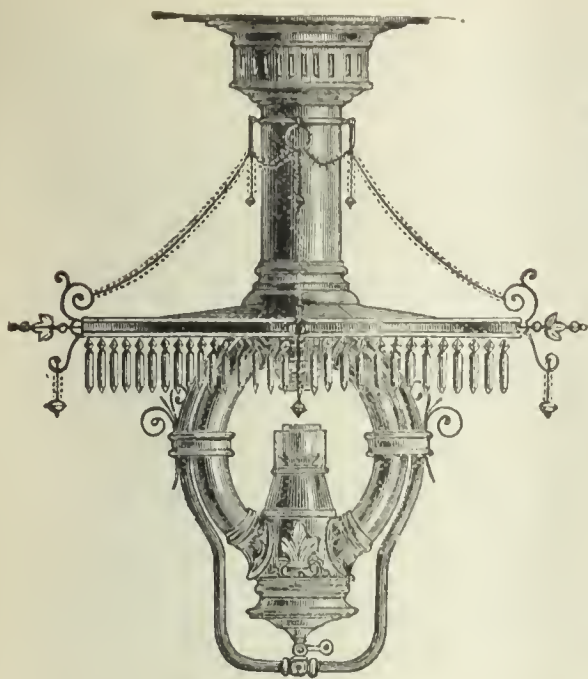

SIEMENS LAMP.

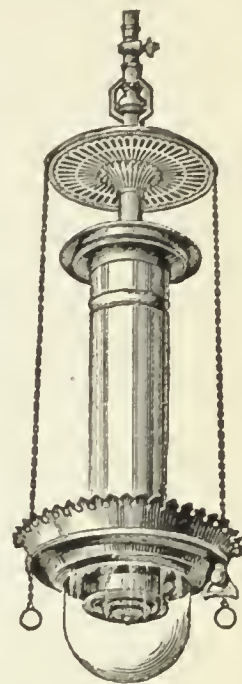

LUNGREN LAMP

THIRTEEN CANDLE POWER PER CUBIC FOOT OF GAS!

This result is obtained

SIMPLY BY THE SCIENTIFIC APPLICATION OF THE REGENERATIVE PRINCIPLE.

Consequently this largely increased illumination is always maintained without further cost and frequent attention.

THE SIEMENS-LUNCREN COMPANY,

N. E. Cor. 21st. St. and Washington Av., Phila., Pa.

THE PATENT "STANDARD" WASHER-SCRUBBER

(KIRKHAM, HULETT & CHANDLER PATENT.)

Has been adopted by gas companies in all parts of the world. Between 300 and 400 companies, with the enormous daily output of over 300,000,000 cubic feet, are now using it. "Standard" Washer-Scrubbers have been erected for the following gas light companies since Jan. 1, 1886:

WALLASEY, ENGLAND.....	750,000 cubic feet.	RICHMOND, SURREY, ENGLAND.....	1,500,000 cubic feet.
NEWARK, ENGLAND.....	350,000 "	BRIDGEPORT, U. S.....	500,000 "
BUFFALO, U. S. (MUTUAL).....	500,000 "	TORONTO, CANADA.....	1,000,000 "
BERLIN, GERMANY.....	1,250,000 "	HARTFORD, U. S.....	1,000,000 "
SO. BRISBANE, AUSTRALIA.....	300,000 "	DETROIT, U. S.....	750,000 "
LEEDS, ENGLAND.....	2,600,000 "	SINGAPORE, CEYLON.....	300,000 "
FURTH, GERMANY.....	400,000 "	BRUNSWICK, GERMANY.....	300,000 "
FREIBURG, GERMANY.....	200,000 "	LILLE, FRANCE.....	750,000 "
NINE ELMS, LONDON.....	3,000,000 "	CADIZ, SPAIN.....	300,000 "
MELBOURNE, AUSTRALIA (2).....	3,000,000 "	READING, ENGLAND.....	2,000,000 "
GLUCKAUF COKE WORKS, GERMANY.	200,000 "	LINCOLN, U. S.....	250,000 "
BOURNEMOUTH, ENGLAND.....	1,000,000 "	ST. LOUIS, U. S. (LACLEDE).....	1,000,000 "
		BROOKLYN, U. S.....	2,000,000 "

That this apparatus is really the *standard* is indicated by the following names of important houses who represent this invention in the different countries of the world:

FRANCE & BELGIUM, Mons. J. A. Berly, 31 Rue Boinod, Paris. HOLLAND & DUTCH COLONIES, Mess. W. Hoven & Zoon, Rotterdam.

GERMANY and AUSTRO-HUNGARY, Berlin-Anhaltische-Actiengesellschaft, Berlin, Moabit, and Dessau.

RUSSIA, Mr. F. Bley, Galernaya, 44, St. Petersburg. SPAIN, Mess. Nicolas, Chamon, Foiret & Cie., 29 Rue Claude-Veilefaux, Paris.

ITALY & MALTA, Sig. E. Canziani, 26 & 28 Portici, Vittorio Emmanuele, Genoa. Sig. Fratelli Scheuer, Via Chiaja, 124, Naples

NEW SOUTH WALES, Messrs. W. Coward & Sons, 143 Queen Victoria St., London.

NEW ZEALAND and VICTORIA, Messrs. G. D. Jennings & Co., 28 Gracechurch St., London.

Companies in the U. S. adopting this apparatus can now be assured of a market for the Ammoniacal Liquor at a remunerative price. Correspondence for purchase of "Standards" and Ammoniacal Liquor is solicited by the

GEO. SHEPARD PAGE, 69 WALL STREET, NEW YORK.

GAS WORKS APPARATUS AND CONSTRUCTION.

GAS WORKS APPARATUS AND CONSTRUCTION.

WORKS: { MILLVILLE, N. J.
FLORENCE, " "
CAMDEN, " "

R. D. WOOD & CO.,

OFFICES: { 400 CHESTNUT ST.,
PHILADELPHIA.

CAST-IRON PIPE 1½ to 72 Inches in Diameter.

Water Machinery and Gas Apparatus.

HEAVY CASTINGS.

HOLDERS,

PURIFIERS,

FLOORS AND ROOFS,

LAMP POSTS,

CONDENSERS,

FLANGED PIPE,

VALVES,

BENCH WORK,

FIRE HYDRANTS,

METER CASES.

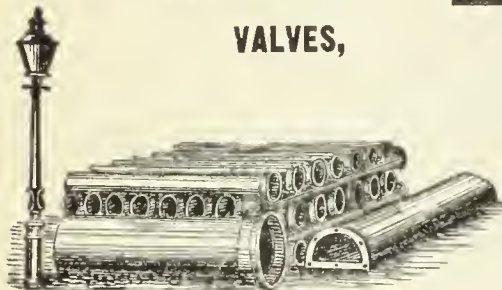

Estimates and Specifications for
NEW WORKS or **EXTENSIONS**
or **ALTERATIONS** of **OLD ONES.**

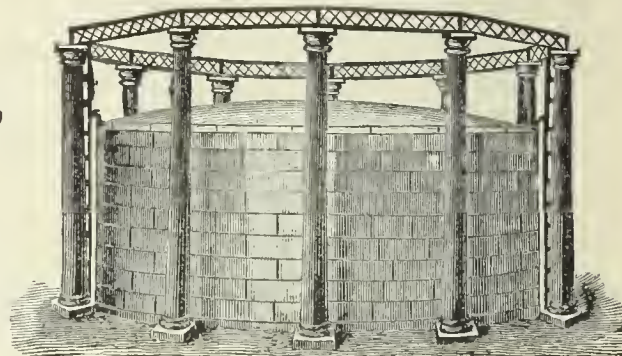

SOUTHWARK FOUNDRY AND MACHINE COMPANY,

Successors to MERRICK & SONS,

GAS APPARATUS,

Holders, Purifiers, Washers, Etc., Etc. Boiler and Tank Work. Steam Engines.
Hydraulic Machinery. Bessemer Plants, Etc.

Washington Ave. and Fifth Street, Philadelphia, Pa.

MORRIS, TASKER & CO.,

Limited,

Builders of Gas Works,

PHILADELPHIA PA.

THE KERR MURRAY MANUFACTURING COMPANY,
Fort Wayne, Ind.

CONSTRUCTING ENGINEERS AND BUILDERS OF

GAS WORKS AND HOLDERS.

Drawings, Estimates, and Specifications Furnished for the Construction of New and the
Rebuilding of Old Works.

MANUFACTURERS OF LATEST IMPROVED APPARATUS FOR COMPLETE AND AUXILIARY OIL AND WATER GAS PLANTS.

Rotary and Steam Jet Exhausters, Rotary Washers, Self-Sealing Mouthpieces,

HYDRAULIC LIFTS FOR PURIFIER COVERS.

"VALVE COMBINATION" FOR OPERATING ONE TO FOUR OR MORE PURIFIERS.

Street Specials, Valves, and Fittings.

COKE CRUSHERS, COAL AND COKE WAGONS, LAMP POSTS.

Iron Roofs, Cutters, and Retort House Floors.

STEAM ENGINES AND BOILERS, IRON COAL SHEDS.

Single and Telescopic Gasholders.

Correspondence is Respectfully Solicited.

GAS WORKS APPARATUS AND CONSTRUCTION.

GAS WORKS APPARATUS AND CONSTRUCTION.

JAMES R. FLOYD,

(SUCCESSOR TO HERRING & FLOYD)

Oregon Iron Works,

531 to 543 West 20th St., N. Y.

Practical Builders of Gas Works,

MANUFACTURERS OF

ALL KINDS OF CASTINGS

AND

APPARATUS FOR GAS-WORKS.

BENCH CASTINGS

from benches of one to six Retorts each.

WASHERS: MULTITUBULAR AND AIR CONDENSERS; CONDENSERS; SCRUBBERS

(wet and dry), and

EXHAUSTERS

for relieving Retorts from pressure.

BENDS and BRANCHES

all sizes and description.

FLOYD'S PATENT

MALLEABLE RETORT LID.

PATENT

SELF-SEALING RETORT LIDS.

FARMER'S

PATENT BYE-PASS DIP-PIPE.

SABBATON'S PATENT

FURNACE DOOR AND FRAME.

BUTLER'S

COKE SCREENING SHOVELS.

GAS GOVERNORS,

and everything connected with well regulated Gas Works at low price, and in complete order.

SELLER'S CEMENT

for stopping leaks in Retorts.

N. B.—STOP VALVES from three to thirty inches—at very low prices.

Plans, Specifications, and Estimates furnished.

Bouton Foundry Co.,

FOUNDERS AND MACHINISTS,

CHICAGO, ILL.

Gas Works Apparatus,

PURIFIERS, CONDENSERS,

Bench Work,

SPECIALS, LAMP POSTS,

SCRUBBERS,

Iron Roofs and Floors.

Plans and Estimates furnished for new works or extensions of old works.

BOOKS.

DISTILLATION OF COAL TAR AND AMMONIACAL LIQUOR.

By GEORGE LUNGE. Price \$8.50.

A TREATISE ON THE COMPARATIVE COMMERCIAL VALUES OF GAS COALS AND CANNELS.

By DAVID A. GRAHAM. 8vo., Cloth. Price \$3.

Orders for these books may be sent to this office.

A. M. CALLENDER & CO.,

42 PINE ST., N. Y. CITY.

CONTINENTAL WORKS.



GASHOLDERS OF ANY MAGNITUDE.

T. F. ROWLAND, Proprietor,

GREENPOINT, BROOKLYN, N. Y.

ENGINEER AND MANUFACTURER OF

GAS-HOLDERS.

CONDENSERS, SCRUBBERS, VALVES,

PURIFIERS, RETORTS, and HY-

DRAULIC MAINS,

and all other articles connected with the Manufacture and Distribution of Gas. Plans and Specifications prepared and Proposals given for the necessary Plant for Lighting Cities, Towns, Mansions, and Manufactories.

H. RANSHAW, Pres. & Mangr. WM. STACEY, Vice-Prest. T. H. BIRCH, Asst. Mangr. R. J. TARVIN, Sec. & Treas.

STACEY MFG. CO.,

MANUFACTURERS OF

Single and Telescopic Gasholders,

IRON ROOFS, BRIDGES, LAMP POSTS,

Water and Oil Tanks, Coal Elevator Cars,

COKE CRUSHERS, BENCH CASTINGS,

And all kinds of Wrought and Cast Iron Work used in the erection of Coal and Oil Gas Works.

Rolling Mill Machinery and Heavy Castings a Specialty.

Foundry:

33, 35, 37 & 39 Mill Street.

Wrought Iron Works:

16, 18, 20, 22, 24 & 26 Ramsey Street.

Cincinnati, Ohio.

BARTLETT, HAYWARD & CO.,

Office, German & Calvert.

BALTIMORE, MD.

Works, Pratt & Scott.

PURIFIERS.

Roofs.
Bench Castings.



SCRUBBERS.

CONDENSERS.

GASHOLDERS.

CONSTRUCTING ENGINEERS AND BUILDERS OF GAS WORKS.

1842. DEILY & FOWLER, 1887.

Laurel Iron Works.

Address, No. 39 Laurel Street, Philadelphia, Pa.

MANUFACTURERS OF

GASHOLDERS,

Single or Telescopic, with Cast or Wrought Iron Guide Frames.

Holder Built Since 1881:

- | | | | | |
|-----------------------|---------------------------|---------------------------|---------------------------|-----------------------------|
| Scranton, Pa. (2d) | Hollidaysburg, Pa. | Jackson, Mich. | Montgomery, Ala. | New Castle, Pa. |
| West Point, N. Y. | Galveston, Texas (2d.) | Kalamazoo, Mich. (3d.) | Newport, R. I. | Long Island City, N. Y. |
| Fitchburgh, Mass. | Marlboro, Mass. | Glen Island, N. Y. | Portland, Oregon. | Macon, Ga. |
| New London, Conn. | Denver, Col. | Warren, Ohio. | Allegheny, Pa. (2d.) | York, Pa. |
| Derby, Conu. | Chicago, Ill. (West Side) | Bath, N. Y. | Atlanta, Ga. (2d.) | Chester, Pa. |
| Bridgeport, Conn. | Pittsburgh, Pa. (S. Side) | Lynn, Mas. | N.Y.City (Central Gas Co) | Hazleton, Pa. 2d.) |
| Allegheny, Pa. (1st.) | Pawtucket, R. I. | New Bedford, Mass. | Lyuchburg, Va. (2d.) | Novelties Exhib., Phila |
| St. Hyaciuth, Cau. | Brookline, Mass. | Waterbury, ConL. | Saylesville, R. I. | State Island, N. Y |
| Norwalk, O. | Sherbrooke, Can. | Deserono, Cau. | Rondout, N. Y. | Saugerties, N. Y |
| Brattleboro, V | Burlington, N. J. (2d) | Hoosic Falls, N. Y. (2d.) | Atlantic City, N. J. | Clinton, Mass. (Lan. Mills) |
| Waltham, Mass. (2d.) | Bridgeton, N. J. | Bethlenem, Pa. | Augusta, Ga. | Chattanooga, Tenn. |
| West Chester, Pa. | Bay City, Mich. | Atlanta, Ga. (1st.) | Waltham, Mass. (2d) | Galveston, Texas. (3d.) |
| Baltimore, Md. | Erie, Pa. | Savannah, Ga. | Mabanoy City, Pa. | Omaha, Neb. |

GAS COALS.

CANNEL COALS.

GAS ENRICHERS.

JAMES D. PERKINS.

PERKINS & CO.,

F. SEAVERNS.

General Sales Agents for

The Youghioghenny River Coal Company's**OCEAN MINE YOUGHIOGHENY GAS COAL.**

The Coal from the Ocean Mine (recently operated by *Messrs. W. L. Scott & Co.*, of Erie, Pa.,) is now used by all the leading Gas Companies in the United States from Maine to Texas, and is recognized as *the only reliable Youghioghenny Gas Coal.* (See Map on p. 87 of this Journal, Feb. 16, '85.)

P. O. Box 3695,
New York.**PERKINS & CO., 228 and 229 N. Y. Produce Exchange.**BEAVER STREET
ENTRANCE.**BRECKENRIDGE CANNEL,
OF KENTUCKY.**

This Colliery was re-opened in June, 1886, since which date the Cannel has been delivered to over sixty of the leading Gas Companies in this country and in Europe. As an enricher ONE TON of this Cannel will do the work of TWO TONS of any other available Cannel, and is more economical than Naptha or Oil of any character. It can be delivered in parcels of one car load or more to any point in the United States or Canada.

(See AMERICAN GAS LIGHT JOURNAL, June 16, '86, pp. 346-7.)

P. O. Box 3695,
New York.**PERKINS & CO., 228 and 229 N. Y. Produce Exchange**BEAVER STREET
ENTRANCE.**JAMES & WILLIAM WOOD,****Gas and Cannel Coal Contractors,**

No. 40 St. Enoch Sq., Glasgow. No. 2 Talbot Court, London.

Proprietors of the **BATHVILLE COLLIERIES** (which produce the celebrated **BOGHEAD CANNEL**), Shields, Shieldmuir, Drumpeller, and other Collieries. This Firm offer

STANDARD CANNELS,

Unequaled as Gas Enrichers.

Analyses, prices, and all further information furnished on application to

Agency for U. S., Room 93, Nos. 2 & 4 Stone St., N. Y. City.

The Standard Oil Company,

REFINERS OF

NAPTHA AND GASOLINES.

ALSO MANUFACTURERS OF

A Special Grade of Naptha for
Gas Companies**FOR ENRICHING COAL GAS.**

Correspondence solicited.

No. 43 Euclid Avenue, Cleveland, Ohio.

To Gas Companies.We make to order **CAP BURNERS** to burn any amount
under a stated pressure. Send for samples.Also, **SERVICE CLEANERS, DRIP PUMPS, and STREET
MAIN PROVING APPARATUS.****C. A. GEFROHER,**

248 N. 8th Street, Phila., Pa.

GOODWIN'S DIRECTORY**OF THE GAS LIGHT COMPANIES of the UNITED STATES & CANADA.**

Price, \$10.00.

Orders may be sent to

A. M. CALLENDER & CO., No. 42 Pine Street, N. Y. City.

COKE CRUSHERS.

Newburgh Orrel Coal Co.,

MINERS AND SHIPPERS OF

Mountain Brook Steam and Smithing Coals,

AURORA, TYRCONNELL & PALATINE GAS COALS.

Foundry & Crushed Coke Shipped Direct from Ovens

Mines Situated at

Newburgh, Flemington & Fairmont, W.Va.

HOME OFFICE,

33 S. Gay St., Baltimore.

CHAS. MACKALL, Gen. Mangr.

CHAS. W. HAYS, Agent in New York,

Room 147, WASHINGTON BUILDING, No. 1 Broadway.

Shipping wharves at Locust Point, Baltimore.

THE DESPARD COAL COMPANY

OFFER THEIR SUPERIOR

DESPARD COAL

To Gas Light Companies and Manufacturers of Fire Clay Goods Throughout the Country.

ROUSSEL & HICKS, } AGENTS. { BANGS & HORTON, }
71 Broadway, N. Y. } 16 Kilby St., Boston.

Mines in Harrison Co., West Va. Wharves, Locust Point, Balt.

Company's Office, 15 German St., Baltimore, Md.

Among the consumers of Despard Coal we name: Manhattan Gas Light Co., N. Y.; Metropolitan Gas Light Co., N. Y.; Jersey City, (N. J.) Gas Light Co.; Washington (D. C.) Gas Light Co.; Portland (Maine) Gas Light Co. Reference to them is requested.

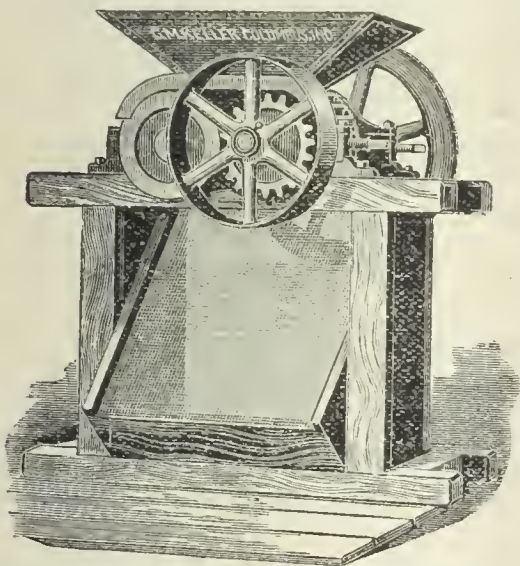

Keller's Adjustable Coke Crusher.

SIMPLE, STRONG, AND DURABLE.

C. M. Keller, Sec. & Supt. Gas Lt. & Coke Co. Columbus, Ind.

Correspondence Solicited.

GAS COMPANIES, ATTENTION!

Increase the demand for Coke by using the

Star Coke Breaker.

SIMPLE, CHEAP, DURABLE. EASILY SHARPENED BY ANY BLACKSMITH.

B. J. ALLEN, Newark Gas Co., Newark, N.J.

King's Treatise on Coal Gas.

The most complete work on Coal Gas ever published

Three Vols. Bound, \$30.

A. M. CALLENDER & CO., 42 Pine St., N. Y.

GAS COALS.

GAS COALS.

THE **PENN GAS COAL CO.**

OFFER THEIR

Coal, Carefully Screened & Prepared for Gas Purposes.

Their Property is located in the Youghiogheny Coal Basin, near Irwin and Penn Stations on the Pennsylvania Railroad, and on the Youghiogheny River.

Principal Office:

209 SOUTH THIRD STREET, PHILA., PA.

Points of Shipment:

Pennsylvania Railroad Piers; Greenwich Wharves, Delaware River; Pier No. 1 (Lower Side), South Amboy, N. J.

Chesapeake & Ohio Railway Coal Agency,

FOR THE SALE OF THE

Superior Kanawha Gas Coals, Cannelton Cannel, Also, SPLINT AND STEAM COALS,

From the Kanawha and New River Regions, on the line of the Chesapeake & Ohio R'way.

C. B. ORCUTT, Sales Agent. | OFFICE, 150 BROADWAY, N. Y.

FRANCIS H. JACKSON, Prest. EDMUND H. MCCULLOUGH, V.-Prest. CHAS. F. GODSHALL, Treas. H. C. ADAMS, Sec.

THE WESTMORELAND COAL CO.

Chartered 1854.

Mines situated on the Pennsylvania and the Baltimore and Ohio Railroads, in Westmoreland County, Penn.

POINTS OF SHIPMENT:

PHILADELPHIA, BALTIMORE, SOUTH AMBOY, N. J., WATKINS (SENECA LAKE), N. Y.

Since the commencement of operations by this Company its well-known Coal has been largely used by the Gas Companies of New England and the Middle States, and its character is established as having no superior in gas giving qualities, and in freedom from sulphur and other impurities.

Principal Office, 224 South 3d St., Phila., Pa.

A. M. SCOTT, PRESIDENT. A. DEMPSTER, C.E., SECRETARY. W. K. GILLESPIE, TREASURER.

MONONGAHELA AND PETERS CREEK GAS COAL CO.,

PRODUCERS OF

Coal Bluff Gas Coal.

MINES LOCATED ON THE MONONGAHELA DIVISION OF THE PENNSYLVANIA RR., IN THE CENTRAL PORTION OF THE PITTSBURGH COAL FIELD.

Points of Shipment—Buffalo, Cleveland, Erie, Chicago, New Orleans.

Since the introduction of Coal Bluff Gas Coal it has taken rank among the few first-class Gas Coals, and acknowledges no superior in gas-giving qualities, ease of working, quality of coke, and freedom from impurities.

Milwaukee Agents, F. R. BUELL & CO., - - - Milwaukee, Wis.

General Office, 43 Sixth Ave., Pittsburgh, Pa.

GAS METERS.

GAS METERS.

GAS METERS.



INTERNATIONAL--1876--EXHIBITION.

The U. S. Centennial Commission

HAVE DECREED AN AWARD TO

HARRIS, GRIFFIN & CO.,

Twelfth and Brown Streets, Philadelphia, Pa. No. 49 Dey Street, N. Y. City, and No. 75 North Clinton Street, Chicago, Ill.

FOR THE FOLLOWING REASONS :

The Exhibit consists of a Series of METERS from the Largest Size Station Meters for the use of the MANUFACTURE OF GAS, to those for the use of the ORDINARY CONSUMER. The Instruments are WELL MADE, RELIABLE as to INDICATION, and embody a number of sundry improvements which, with the general character of the Exhibit, entitle the whole to commendation.

Attest—J. L. CAMPBELL,
Secretary, pro-tem.

Signed—A. T. GOSHORN,
Director General

J. B. HAWLEY,
President

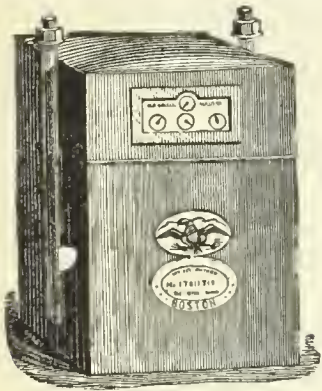

Dry Gas Meter.

With 39 years' experience and the best facilities for manufacturing, is enabled to furnish reliable work and answer orders promptly.

NATHANIEL TUFTS,

No. 153 Franklin Street, Boston, Mass.,

MANUFACTURER OF

DRY GAS METERS.

Station Meters of any Capacity.

Test and Experimental Meters, Pressure Registers, Pressure Gauges, Pressure and Vacuum Gauges.

METER PROVERS, PHOTOMETERS, STREET LANTERNS, ETC., ETC.

Patent Cluster Lanterns for Street Illumination.

SCIENTIFIC BOOKS.

We are prepared to furnish to Gas Managers, and others interested in the topics treated of, the following books, at prices named :

KING'S TREATISE ON THE MANUFACTURE OF COAL GAS. Three vols.; \$10 per vol.	PRACTICAL TREATISE ON HEAT, by THOMAS BOX. Second edition. \$5.	THE GAS MANAGER IN THE LABORATORY, by a Practica Student. 8vo., Cloth. \$1.50.
GAS MANUFACTURE, by WILLIAM RICHARDS. 4to., with numerous Engravings and Plates, in Cloth binding. \$12.	GAS WORKS—THEIR ARRANGEMENT, CONSTRUCTION, PLANT, AND MACHINERY. \$8.	THE DOMESTIC USES OF COAL GAS, AS APPLIED TO LIGHTING, by W. SUGG. \$1.40.
THE GAS ANALYST'S MANUAL, by F. W. HARTLEY. \$2.50.	COAL; ITS HISTORY AND USE, by PROF. THORPE. \$3.50.	DISTILLATION OF COAL TAR AND AMMONIACAL LIQUOR by GEO. LUNGE. \$8.50.
TECHNICAL GAS ANALYSIS. \$2.80.	THE GAS WORKS OF LONDON, by COLBURN. 60 cents.	A TREATISE ON THE COMPARATIVE COMMERCIAL VALUES OF GAS COALS AND CANNELS, by D. A. GRAHAM 8vo., Cloth. \$3.
GAS MANAGER'S HANDBOOK, by THOS. NEWRIGGING. \$4.80.	THE GAS FITTER'S GUIDE, Showing the Principles and Practice of Lighting with Coal Gas, by JOHN ELDREDGE. 40 cents.	GAS AS A SOURCE OF LIGHT, HEAT, AND POWER, by C. J. R. HUMPHREYS. 10 cents.
GAS CONSUMER'S GUIDE. \$1.	GAS WORKS, AND MANUFACTURING COAL GAS, HUGHES. \$2.20.	GAS COMPANIES DIRECTORY. \$10.
A GUIDE TO GAS LIGHTING. 40 cents.	THE MANAGEMENT OF SMALL GAS WORKS, by C. J. R. HUMPHREYS. \$1.	GAS VERSUS ELECTRIC LIGHT. 50 cents.
GAS MEASUREMENT AND GAS METER TESTING, by F. W. HARTLEY. \$1.60	MANUAL FOR GAS ENGINEERING STUDENTS, by D. LEE, 40 cents.	PURIFICATION OF COAL GAS, by R. P. SPICE. 8vo. \$3.
GAS CONSUMER'S HANDBOOK, by WILLIAM RICHARDS, C.E.; 18mo., Sewed. 20 cents.	HOW TO MANAGE GAS, by F. WILKINS. Paper. 20 cents.	
A PRACTICAL TREATISE ON GAS AND VENTILATION with Special Relation to Illuminating, Heating, and Cooking by Gas, by E. E. PERKINS. \$1.25.		

The above will be forwarded by express, upon receipt of price. We take especial pains in securing and forwarding any other Works that may be desired, upon receipt of order. All remittances should be made by check, draft, or post office money order.

A. M. CALLENDER & CO., No. 42 Pine Street, New York.

KING'S TREATISE ON COAL GAS.

The most complete work on Coal Gas ever published. Three vols., bound \$30.

A. M. CALLENDER & CO., No. 42 Pine Street, New York.

GAS METERS.

GAS METERS.

GAS METERS.

GEO. J. McGOURKEY, Pres. WM. H. McFADDEN, Vice-Pres. (Phila.). WM. N. MILSTED, Gen. Supt. & Treas. (New York). WM. H. DOWN Sec.

AMERICAN METER COMPANY,

WET AND DRY GAS METERS.	PRESSURE REGISTERS.	METER PROVERS.
STATION METERS.	PRESSURE & VACUUM REGISTERS.	PORTABLE TEST METERS.
EXHAUSTER GOVERNORS.	PRESSURE & VACUUM GAUGES.	EXPERIMENTAL METERS.
DRY CENTRE VALVES.	CRESSON GAS REGULATORS.	AMMONIA TEST METERS.
GOVERNORS FOR GAS WORKS.	MARSLAND WATER METERS.	BAR AND JET PHOTOMETERS.

Manufactories:
512 W. 22d St., N. Y.
Arch & 22d Sts., Phila.

GAS STOVES,
SUGG'S "STANDARD" ARGAND BURNERS,
SUGG'S ILLUMINATING POWER METER,
Wet Meters, with Lizar's "Invariable Measuring" Drum.

Agencies:
177 Elm Street, Cincinnati.
214 & 216 N. Wells Street, Chicago.
810 North Second Street, St. Louis.
122 & 124 Sutter St., San Francisco.

HELME & McILHENNY,

(Successors to Harris & Brother. Established 1848)

GAS METER MANUFACTURERS,

CONTINUE AS HERETOFORE AT THE OLD ESTABLISHMENT,

Nos. 1339 to 1349 Cherry Street, Philadelphia, Pa.,

To Manufacture Wet and Dry Gas Meters, Station Meters, Experimental Meters, Meter Provers, Center Seals, Pressure Registers
GOVERNORS, INDICATORS, PHOTOMETERS, & ALL OTHER KINDS OF APPARATUS FOR USE IN GAS WORKS.

From our long practical experience of the business, and from our personal supervision of all work, we can guarantee all orders to be executed promptly and in every respect satisfactorily.

WM. WALLACE GOODWIN, Prest. and Treas.

WM. H. MERRICK, V.-Prest.

S. L. JONES, Sec.

S. V. MERRICK, Supt.

THE GOODWIN GAS STOVE AND METER COMPANY,

Successors to W. W. GOODWIN & CO.

1012, 1014 and 1016 Filbert St., Phila., Pa. 142 Chambers St., New York.
76 Dearborn St., Chicago, Ill.

WALDO BROS., Agents, 88 Water St., Boston.

MANUFACTURERS OF THE "SUN DIAL" GAS STOVES, FOR COOKING AND HEATING PURPOSES.

Dry and Wet GAS METERS, Station Meters (Square, Cylindrical or in Staves) Glazed Meters, King's and Sugg's Experimental Meter Lamp Post Meters, Etc., Etc., Meter Provers (sizes 2, 5 and 10 feet), Pressure Gauges of all kinds, Pressure Registers, Pressure and Vacuum Registers, Pressure Indicators (sizes 4 inch, 6 inch and 9 inch), King's Pressure and Vacuum Gauges, Dry and Wet Centre Seals, Dry and Wet Governors, Exhauster Governors, Photometers of all descriptions. Letheby's Sulphur and Ammonia Test Apparatus complete—also Testing and Chemical Apparatus of all kinds, and of the most perfect description, for all purposes relating to Gas.

GOODWIN'S IMPROVED LOWE'S JET PHOTOMETER.

Agents for Bray's Patent Gas Burners and Lanterns.

Special attention to repairs of Meters, and all apparatus connected with the business.
All work guaranteed first class in every particular, and orders filled promptly.

G. B. EDWARDS, Mang'r, New York.
E. H. B. TWINING, Mang'r, Chicago.
Represented by A. B. STANNARD.

D. McDONALD & CO.,

GAS METER MANUFACTURERS.

(Established 1854.)

51 Lancaster St., Albany, N. Y. 34 & 36 West Monroe St., Chicago, Ill.

STATION METERS, EXPERIMENTAL METERS, METER PROVERS, PRESSURE & VACUUM REGISTERS, PRESSURE GAUGES, ETC.

Also STAR GAS STOVES, RANGES, and HEATING STOVES.

We use only the very best materials, and employ the most skilled labor, and by our long experience (32 years) and personal supervision of every detail, we feel justified in assuring the public that our goods will give perfect satisfaction. Every Meter emanating from our establishment will bear the State Inspector's BADGE, and will be fully warranted by us. Our Annual and Calendar will be sent to Gas Companies upon application.

GAS STOVES.

GAS STOVES.

GAS STOVES.

THE GOODWIN GAS STOVE AND METER CO.,

1012-18 Filbert St., Phila., 142 Chambers St., N. Y., 76 Dearborn St., Chicago.

Agents, WALDO BROTHERS, 88 Water Street, Boston.

WM. W. GOODWIN, PRES. & TREAS.
W. H. MERRICK, VICE-PRES.
LEWIS JONES, SEC.
SAMUEL V. MERRICK, SUPT.

SOLE MANUFACTURERS OF THE

G. B. EDWARDS, Mang'r, N. Y.
E. H. B. TWINING, Mang'r, Chicago.
Represented by A. B. STANNARD.

"SUN DIAL" GAS STOVES

The Most Economical, Efficient, and Durable Gas Stove Made.

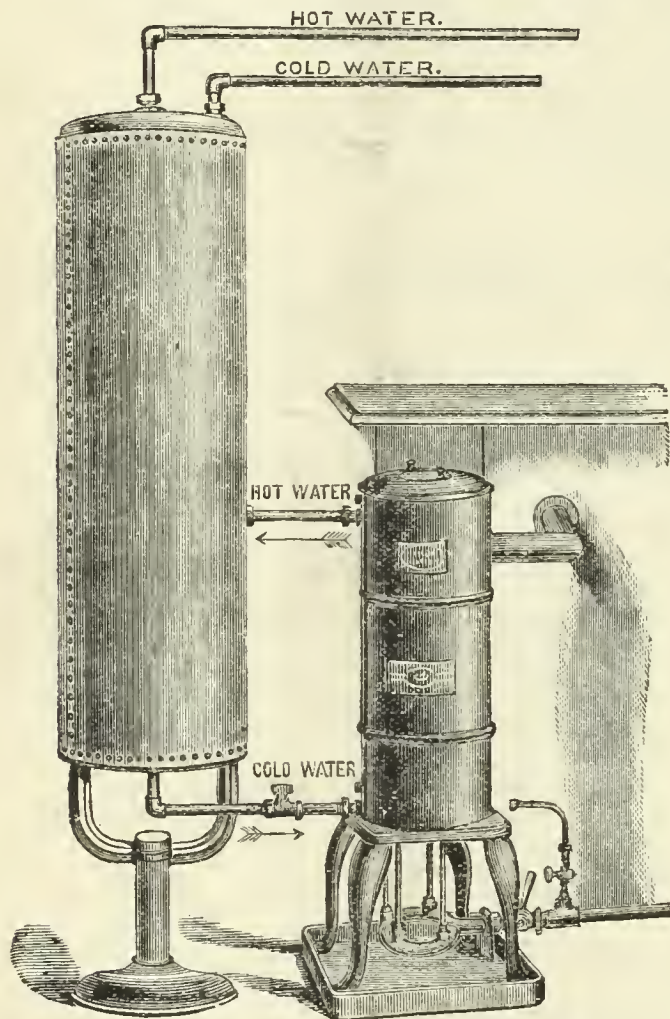

I.—Safety Hot Water Generator and Boiler.

Safety Hot Water Generator and Boiler.

Cut I. represents our Safety Gas Hot Water Generator and Boiler, arranged for home use. This most easy, quick, and economical way of preparing a warm bath, or for heating water for any domestic purpose, entirely supersedes any necessity for the use of ranges or stoves—a great comfort, particularly in hot weather. The boiler being self-filling, as the hot water is drawn off, can never become empty, thus preventing the possibility of any accident.

We beg to call attention to the cast iron pan which is now attached to the legs of the Generator (see illustration). This is to catch the drippings from the Coil, which many persons suppose come from a leak, when in fact they are produced by condensation. This condensation is caused by the hot flame coming in contact with the coil filled with cold water.

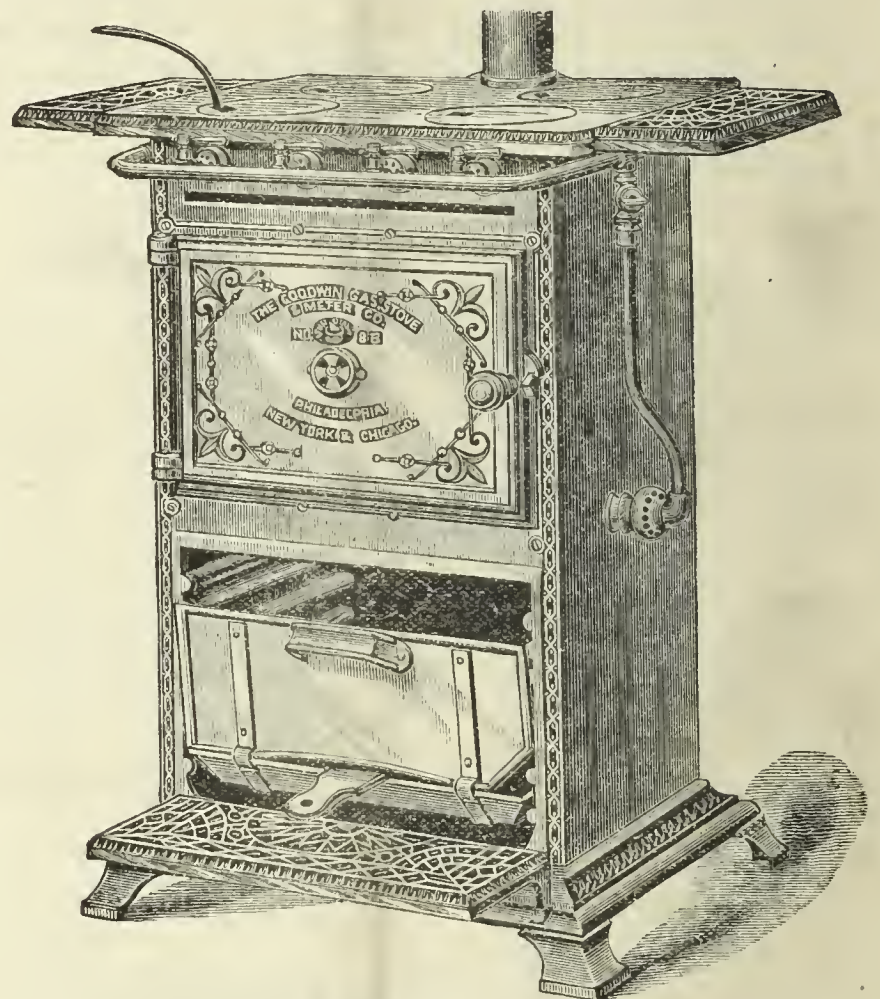

II.—Gas Cooking Stove No. 8 B.

New Style Gas Cooking Stove.

Cut II. represents our New Style Cooking Stove. As will be seen, it has an ornamented cast iron base and front, and extension shelves. The oven burner, which is atmospheric (unless otherwise ordered), is of an entirely new and improved pattern (patent applied for). The ovens are of greater capacity than those of the old style. The top, in conjunction with the outlet pipe, is designed to carry off all products of combustion; hence the outlet pipe must be connected with a flue, or the stove will not work properly.

This Stove has 4 boiling burners in top of hot plate. All fittings are nickel plated. We are making this style of Cooking Stove in the following sizes—viz., No. 7 B, No. 8 B, No. 9 B, and No. 10 B.

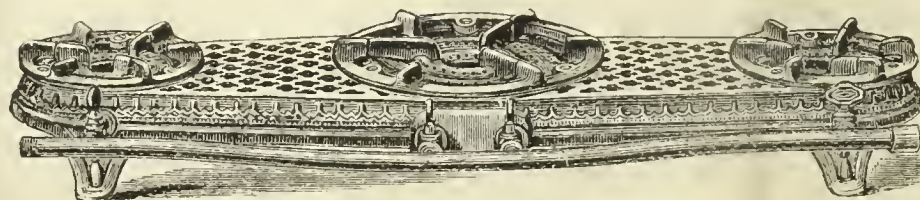

III.—Improved Hot Plate, No. 108.

New Style Hot Plates.

Cut II. represents our New Style of Hot Plates, of which we are making No. 106 (two small boiling burners), No. 107 (two medium sized boiling burners), and No. 108 (two medium and one large boiling burner). See new Catalogue and Price List for further particulars.

THE AMERICAN

GAS LIGHT JOURNAL

REDMAN & KENN, N. Y.

PUBLISHING OFFICE No. 42 PINE STREET

DEVOTED TO THE INTERESTS OF ILLUMINATION, VENTILATION, WATER SUPPLY AND DISTRIBUTION, & GENERAL SCIENCE.

VOLUME XLVI.—No. 10.
Whole No. 670.

NEW YORK, MONDAY, MAY 16, 1887.

{ \$3 PER ANNUM,
IN ADVANCE.

A. M. CALLENDER & CO., Proprietors. C. E. SANDERSON, Manager.
JOS. R. THOMAS, C.E., Editor. T. J. CUNNINGHAM, Asst. Editor.

ENTERED AT THE POST OFFICE AT NEW YORK, N. Y.
AS SECOND CLASS MATTER.

Published on the 2d and 16th of each month, at No. 42 Pine Street, N. Y.

Terms of Subscription, Including Postage.—For the United States and Canada, \$3 per annum. European countries, \$3.50 (15 shillings—18 francs). All payments to be made in advance. Single copies, 15 cents.

Remittances should be made either by post-office order, registered letter, or bank draft on New York, payable to the order of A. M. Callender & Co.

Correspondence.—Wishing to make this JOURNAL a gazette of intelligent discussion to those of our readers who may wish to gain or give information on the subjects to which its columns are devoted, correspondence is solicited for publication from all who make the study of those subjects a pleasure or a profession.

The American News Company, Nos. 39 and 41 Chambers street, New York, are agents for this JOURNAL. Newsdealers will send orders to them.

CONTENTS.

An Asterisk (*) denotes an illustrated article.

EDITORIALS—

The St. Louis Meeting.....	309
Gov. Hill's Capsule Memorandum.....	309
The Chicago Gas Trust.....	310
The Selection of Cast Iron Pipe, by J. H. Decker.....	310
Death of Mr. O. C. McCurdy.....	310
Third Annual Meeting of the Ohio Gas Light Association—Official Report—Concluded from page 284.....	311
The Relative Cost of Coal and Water Gas, by Geo. H. Christian, Jr.—Discussion—Election of Officers—Response of President Printz—Naming Place of Meeting—In Memoriam—As to Changing Time of Meeting—Votes of Thanks—Adjournment.	
The Relation of Coal Dust to Mine Explosions.....	316
* The "Richelieu" Coke Stove.....	316
* Has the Length of the Photometer Bar any influence in Determining the Results of the Observations, by D. Coglievina, C.E.....	317

ITEMS OF INTEREST FROM VARIOUS LOCALITIES..... 318

Failure of a Gas Company—Public Lighting at Galveston, Texas—At the Risk of Repetition—Increasing its Scope—Still Spreading—To Whom the Contracts were Awarded—To Appeal—Naming Chicago's Gas Meter Inspector—New Gas Company—Annual Election, People's Company, Chicago, Ill.—Annual Election, Wilmington, N. C.—Killed by Electricity—Another Death—Replaced by Gas—Mr. Hopper's New Address—Look Out for the Fraud—To Build the Springfield (Mass.) Gasholder—The Cleveland (O.) Natural Gas Ordinance—New Rates for Gas at Appleton, Wis.—The Montclair (N. J.) Gas Holder—Another New Holder—To Go Ahead—Annual Meeting, Pittsfield, Mass.—Passed and Vetoed—Some Contracts Recently Secured by Mr. Weber—Progress Made by the National Gas Fuel and Light Company—To Supply the Meters—Gas Coal Bids—Cheaper Gas for Detroit, Mich.—The War is Ended—A Narrow Escape—Delaware (Ohio) Makes the Change—Good for Woonsocket, R. I.—Fire—New Works at Winston, N. C.—New Holder—Uncle Sam's Lighting Bill—Gas Works for Gravesend, N. Y.—Election of Directors—Agitating the Subject.

CORRESPONDENCE—

A Letter from the President of the Port Hope (Ont.) Gas Company.....	321
State of the German Coal Trade.....	322
Bidding Good-by to Mr. Pratt.....	322
Paying the Electric Piper in Brooklyn, N. Y.....	322
The Cost of Public Electric Lighting in Worcester, Mass.....	322
The Market for Gas Securities.....	322
Reorganized.....	322
Stealing Street Lamps.....	322
Light for Central Falls, R. I.....	322

THE ST. LOUIS MEETING.

Telegraphic advices from St. Louis, Mo., bearing date of May 13, confirm our prediction that the "Tenth Annual" would be a grand success. The thermometer, however, persisted in keeping at an unreasonable height, although cooling showers afforded an occasional offset. The attendance of members footed up 110, and 29 additional names were added to the roll. The visiting delegation included Mr. C. J. R. Humphreys, Secretary of the American Association; Mr. Jno. P. Harbison, of Hartford, Conn.; Capt. W. H. White, of New York, and many others. Papers were read by Messrs. Egner, Gimper, Cosgrove, Chollar, Schinrock and Dunbar. The election for office bearers resulted in the choice of Emerson McMillin, President; G. G. Ramsdell and E. J. King, Vice-Presidents; and A. W. Littleton, Secretary. Messrs. C. J. R. Humphreys, G. A. McIlhenny and W. H. White were elected to Honorary Membership. The discussions were animated and important. The banquet was a tremendous success, 125 guests participating therein. Our Official Report of the proceedings will, as usual, appear in due course. The next annual meeting is to be held in Chicago, Ills.

GOV. HILL'S CAPSULE MEMORANDUM.

Gov. Hill, the chief executive officer of the great State of New York, is, in some respects, a very small man, and perhaps that smallness is best illustrated when he is beheld struggling with matters, foreign to routine politics, which pertain to the conservation or protection of important commercial interests belonging to the first Commonwealth of the Union. To insist by mere mouth proclamation that one is a democrat is hardly sufficient proof that the shouter is a democrat in action—of course, we use the word democrat in its broad sense, and not as applied to particularize a political faction. If, then, democracy means the selection, by a people, of delegates to carry on properly and compactly the public policy of that people, it is fair to assume that those chosen to execute the sovereign mandate should be held accountable for the manner in which they execute such trust. With that understanding let us endeavor to find out how New York's self-proclaimed "democrat" has treated the business of gas supply in the Empire State.

When, something like two years ago, the gas reformers of New York city turned their 'prentice hands in the direction of our gas supply, neither indignation nor ink was spared in their boisterous attempts at "creating public sentiment" against the gas companies. The great moral(?) engines—the daily newspapers—took up the cudgels; and, for the nonce, managing editors, city editors, and even the reporters were transformed into gas engineers. We were—for that matter we are yet, as witness the late columns of the *Daily Herald*—treated to abstruse (for they were perfectly unintelligible) dissertations on pressure, candle power, meters, etc., in particular, and to volumes of abuse in general, anent the moral obliquity of the gas purveyors. When a cherry-red heat had been developed in the city, the reformers piped the indignation gases into the convenient gasholding legislative halls at Albany, and there the blast was applied which soon brought the refractory material up to a properly superheated state. In the name of the people the metropolitan gas companies were ordered to sell gas at \$1.25 per thousand; and the democrat-

of-democrats decided that the communistic measure should become a law. If communism is democracy then Gov. Hill was right; but there are many, however, who hold to the opposite of both portions of that corollary—notably those who invested money in gas stocks on the strength of the implied contract between the incorporators of those companies and the State.

New York city disposed of, attention is subsequently called to Brooklyn. The first reformer, ex-car conductor Graham, suddenly elevated from the rear platform and the custody of a bell-punch, to the altitude of a lawmaker, asserts that Brooklyn ought to have illuminating gas at the rate of \$1.25 a thousand, possibly because he thought car drivers, conductors and hostlers might thus be induced to forswear their beer and indulge in gas instead. Why did he not go a step further, and in a more likely direction, too, by insisting that bread should be sold at a cent a loaf? But perhaps he will do that next time. Reformer No. 2, Senator Griswold, who, we believe, is a dealer in diamonds and watches, thought \$1.50 a thousand would be a fair figure. How would it strike him if his confreres said that watches—most necessary to enable the laboring man to post himself of the approach of his working hour—be sold at such a figure? We fear that the Griswold sauce served with the Griswold gas goose would lose its flavor when employed as a condiment for seasoning the Griswold watch gander. The Senate saw fit to say that neither \$1.25 nor \$1.50 suited the Brooklyn situation, and, in their mercy, adjusted the rate at \$1.60. Passing on to the Governor, the measure met with his sanction, which sanction was accompanied by the following capsule memorandum:

“It would have been preferable if, instead of the passage of this measure regulating the price of gas in Brooklyn by act of the Legislature, there had been passed a general law providing for the creation of a State Gas Commission, whereby the price of gas in Brooklyn, as well as in the rest of the cities of the State could be determined by a fair and impartial tribunal, after an investigation of all the facts, and a hearing of all the parties interested. This measure having passed the Legislature with great unanimity, and the propriety of some reduction in Brooklyn being so clear, I have felt it incumbent upon me to approve this bill. If it shall hereafter be demonstrated that any injustice has been done any of the gas companies of Brooklyn, I will next year recommend that the wrong be remedied in some shape. Having last year approved a bill fixing the price of gas to be charged in New York city, I cannot consistently withhold my approval from this measure. I trust that next year a State Commission bill will be enacted. The price of gas is very high in Brooklyn, when compared with other large cities, and this fact has had great weight in influencing my decision on this bill. The people seem entitled to a reasonable reduction, and this bill is apparently the only relief available at the present time.”

Comment on this pill-gilding document seems unnecessary, save to remark that there is no valid reason for consistency in wrong-doing; and to add that in order to be a democrat it is necessary to be in the right. In conclusion, we may admit that we, with the Governor, “Trust that next year a State Commission bill will be enacted.” Having looked over the situation we fear that Gov. Hill still needs to *tell* the people that he is a democrat; certainly the gas suppliers might be excused for doubting his standing in that particular. As a democrat he should repel prejudice in its assaults upon property.

THE CHICAGO GAS TRUST.

The consolidation of the gas business of Chicago (Ills.) is now to all intents and purposes an accomplished fact. One of those most largely interested in the affair, presumably speaking as to the operation of the various plants comprising the syndicate, is reported to have said that, “There has been no consolidation as a matter of fact; the Chicago Gas Trust Company has simply purchased the stock (or a majority of the same) of the existing companies, and will run them under one general management.” As we understand the arrangement the capital stock of the Trust has been fixed at \$25,000,000, and the Trust guarantees payment of interest on the authorized bond issue, where such existed, of the companies absorbed. The general officers of the Trust are: Sidney A. Kent (Chicago), President; W. L. Elkins (Phila., Pa.), Vice-President; C. R. Cummings (Chicago), Treasurer; P. A. B. Widener (Phila., Pa.), Chairman Finance Committee; C. T. Yerkes (Chicago), Chairman Executive Committee. It is also proposed to secure entire control of the electric light supply in Chicago; and it is asserted that one of the gas plants will be employed solely on the manufacture of a cheap fuel gas. The general understanding is that gas in the city proper shall be sold at the rate of \$1.25 per thousand—an increase of 25 cents from the old Chicago Company’s “war tariff.” In the suburban districts a somewhat

higher charge is to rule. Many minor details are yet to be adjusted, but the above affords a fair outline of the general features of the scheme.

[Communicated Article.]

The Selection of Cast Iron Pipe.

By J. H. DECKER.

Responding to your invitation to give my views on the subject of cast iron pipe, as presented by Galen W. Pearsons, C. E.—the JOURNAL was in error in publishing Mr. P’s given name as George—at the Sixth Annual Meeting of the American Water Works Association, and republished in your issue of April 16, I will say:

I agree fully with my friend, Pearsons, in every idea presented, except in the matter of his final advice about “How to get good pipe.” With an experience of twenty odd years I can fully concur in the statement that uneven thickness of pipes and castings constitutes “one of the most common and serious faults” we have to contend with. In fact, I might go a step further and say that *it is* the most serious and common fault.

Some years ago we were greatly annoyed by lack of uniformity in the quality of the iron used. We would find one length of pipe made out of good, soft, free iron, while probably the very next specimen would be hard as a “chill,” and would successfully resist any attempt to chip or drill it. Of late years, however, that faultiness has been greatly ameliorated, consequently we are not so often confronted by hard iron; but the pipe one-half inch thick on one side, and one-quarter inch on the other, we still have with us.

The necessity for a reform in this matter is apparent to every man who has pipe to lay; but will buying pipe “by the lineal foot instead of by the ton” effect the reform? I cannot agree with my friend, Pearsons, that that will offer any incentive to the manufacturer to produce pipe of a more uniform thickness. When we buy by the ton it is to the interest of the manufacturer to work in all the iron possible, and while one side of the pipe will be of the proper thickness, the other side will be found from ten to twenty per cent. *too thick*, and wherein have we bettered our condition?

The same argument will, I think, hold good on the question of buying special castings by the piece, instead of by the pound; for whether it be pipe or special castings, the *weight* yet remains as the principal factor in determining the cost. Therefore I should say: To get good pipe decide, first, upon the thickness of iron your special conditions may require. For gas pipes to be laid and used under the ordinary conditions and circumstances, I consider the following a good standard:

Size of Pipe, Inches.	Thickness of Shell, Inches.	Weight (lbs.) per foot foot of shell.	Weight (lbs.) per length of 12 ft., including bells.
3	.32	12.2	152
4	.37	15.9	206
6	.44	27.8	364
8	.44	36.5	475
10	.45	46.2	602
12	.50	61.4	801

See that the iron used will show an ultimate strength of not less than 16,000 pounds per square inch. Have every pipe submitted to a careful test for uniformity of thickness, rejecting every length that does not fulfil the conditions. Require that no length of pipe shall deviate more than five per cent. from the allowed weight. If more than five per cent. under, reject the pipe; if more than five per cent. over, simply do not pay for the excess; and with the latter practice well understood, the manufacturer will be very apt to keep out overweight.

There is no good reason why the above conditions cannot be complied with by every manufacturer of pipe; and if they are you will be pretty certain to get good pipe. Further, it then becomes a question of no importance whatever whether you buy by the foot or by the ton. Another point involved in the purchase of gas pipes must be borne in mind. They do not want to be coated, particularly on the interior—the moist vapors of the gas having a tendency to dissolve the coating, you soon have the latter deposited in your drips, services, etc. It is also a very fruitful source of joint leakages.

But as I am rather wandering from the subject under discussion, I had better close it.

HANNIBAL (MO.) GAS WORKS.

DEATH OF MR. O. C. McCURDY.—On April 26, O. C. McCurdy, late Superintendent of the Mankato (Minn.) Gas Light Company, came to his death in the purifying room of that works. It is supposed that he was overcome by an escape of gas. Deceased was formerly a resident of Van Wert, Ohio, and was well known to the Western fraternity.

[OFFICIAL REPORT—Concluded from page 284.]

Third Annual Meeting of the Ohio Gas Light Association.

HELD AT THE BECKEL HOUSE, DAYTON, OHIO, MARCH 16 AND 17, 1887.

SECOND DAY—MORNING SESSION.

Mr. Geo. H. Christian, Jr., of Norwalk, read his paper, entitled—

THE RELATIVE COST OF COAL AND WATER GAS.

The past few years bear witness to the many improvements that have been made in all branches of industry. We find the old, crude, slow methods and machinery have given place to new, handier, more rapid processes, and a far better adaptation of means to the ends attained.

From the fact that the gas field has been one, until lately, almost free from competition, and the product of manufacture considered a luxury, gas men have not been forced to practice the closest economy, nor to seek for labor-saving machinery, but have gone on in their old way, feeling well rewarded when earning a fair per cent. on the capital invested. So conservative, indeed, have they been in the past that outside capitalists, seeing the many inducements offered, have availed themselves of the opportunity to compete for business with the old-established companies, and in this way have brought the price of gas, in many places, to a ruinously low figure as compared with that of other cities where there has been no gas war. This want of uniformity in the price of gas, and the apparent inconsistency on the part of the various gas companies, have created a strong public sentiment against gas companies in general.

But rapid as have been the changes in the past, we cannot close our eyes to others equally great that faintly, yet surely, show themselves on the future horizon, and it is our duty to keep pace with these improvements and to prepare for all changes (radical though they be), lest we be swept from the field.

The tendency of the times is to low prices in all commodities, and we must fall in line, recognizing the claims of the people upon us as the dispensers of, if not a necessary of life, at least one of its prime comforts, and supply gas at a figure within the reach of all. Doing this, its field as an illuminant alone will certainly be greatly enlarged. From a financial point of view, we will find it absolutely requisite to practice the closest economy, for we have no more the lighting field to ourselves. Electricity on the one hand and oil on the other are struggling for a share of our business, and you all realize with what success. So great a competitor, in fact, has electricity become that we are advised by many of the leading men in the gas business to absorb it and become the dispensers of both gas and electricity; but to absorb means to buy up all opposition plants. Our only security lies in our ability to furnish electric light in conjunction with gas for less than the electric companies can do it themselves; then, and not till then, can we with certainty control that business.

Having been connected for the past few years with the building of gas works and the manufacture of water gas, I have requested the privilege of presenting to this Association some facts and figures as to its cost of manufacture, and relative value compared with coal gas, and hope to be able to show you how economically these two processes can be worked together in any section of country where the price of gas coal is low, and naphtha or crude oil can be had at reasonable figures.

I need not enter into the details of a water gas plant, nor explain minutely the process of the manufacture of the gas. All apparatus of this nature consists of a generator and superheater, cupolas of wrought iron, shell-lined throughout with firebrick. The generator contains a bed of hard coal or coke, from 3 to 5 feet in depth. In the interior of the superheater there is left an open gas space, from 2½ ft. to 4 ft. square, depending upon the size of the apparatus. At a point about 3 feet from the bottom of this flue an open firebrick arch is built across it, and the space above this arch, to the top of the superheater, is filled in loosely with broken firebrick. The flue connections between the top of the generator and bottom of superheater are made either with internal fire-tile flues or outside pipe.

When the coals in generator have been brought to a red heat, by means of a fan-blast, and the superheater bricks are white-hot, gas is made by shutting down air-blast valves, closing valve to stack, and admitting steam below the coals, and naphtha, or crude oil, above. The gases then formed pass through the superheater into wash-box, scrubbers, condensers, purifiers, meter, to holder.

You will see from this brief description of the process that the cost of labor will be at a minimum, because much of the material used is in a liquid form, and the quantity of coal handled greatly lessened.

There are no more difficulties attending the manufacture of water gas

than are met with in coal gas works. The man handling the apparatus must be attentive to his duties, and keep his fire free from clinkers and fine ashes. There are various methods of introducing the oil, and much depends upon its being done properly. The steam should, first, be turned on, and then the oil, at first slowly, reaching its maximum flow about the middle of the run. In closing down a run the oil should be shut off first, a few minutes before the steam, as only in that way can you be certain of obtaining all the benefit of your oil in gas.

Water gas is not a recent invention; its history dates far back. It has, however, had a greater practical application in this country than in any other, and especially east of the Alleghenies, where the price of hard and soft gas coal is more nearly the same. West of this State also, at Chicago, and many other cities in Illinois and Wisconsin, it has been introduced. The fact of its general introduction into two of the largest cities of this country should, of itself, be a big card in its favor. We can show, too, that, both practically and theoretically, this gas can be made cheaper than coal gas, and (if not superior for all purposes) at least equal to it in every respect.

It is not necessary for me to say that there have been many difficulties met and solved by the early workers in this field, for that is the history of all new inventions. The best results so far obtained on a daily make of 300,000 cubic feet have been 1,000 cubic feet of 20-candle gas from 50 pounds of hard coal or coke and 4 gallons of naphtha. The labor required for this amount of gas per day would be two men to attend to the apparatus, two to the boiler and engine, and one to handle coal. These, with superintendent and man in purifying room, make seven men all told. The cost for purifying material will be slight, and the wear and tear also slight. One double set, capable of producing 300,000 cubic feet per day, will last an average of 2½ years without relining, and this is but renewing the inner lining at an expense not exceeding \$300. Add to this the renewing of the loose firebrick in superheater, twice a year, at a total cost, in 2½ years, of \$200—making a total of \$500. The life yield of a double set of the above size would be 280 million cubic feet. These items include all the expenses involved in the manufacture of water gas.

Now, let us see what will be the cost of coal gas. From one ton of coal we have 10,000 cubic feet of 16—17 candle gas, with 900 pounds of coke, 10 gallons of tar, and 20 gallons of ammoniacal liquor as salable residuals. The labor of 18 men would be required in the retort house for the manufacture of 300,000 cubic feet daily, 2 men in purifying house, and a superintendent, and you have a total of 21 men. There are two materials used as enrichers—cannel coal and naphtha. Of the former, for a 20-candle gas 30 per cent. of total amount of coal will be required, and of naphtha, three-fourths of a gallon per 1,000 cubic feet of carburated gas. The wear and tear in coal works is a large item of expense. The average life of a bench of sixes is 450 days, and the life yield about 22 million cubic feet. The renewal of said bench would cost \$600.

We have now arrived at the cost of each gas in the holder. The relative cost of hard and soft coal varies greatly, according to locality; an average in this State would be as 1½ : 1; and naphtha to soft gas coal, weight for weight, 3½ : 1.

What results will we get by combining these processes, in this State where gas coal is cheap? We have, as residual from the gas coal, 900 pounds of coke; burning this in water gas generator, with addition of 72 gallons of naphtha we would have 18,000 cubic feet of 20-candle gas—making in this proportion, one-third coal to two-thirds water gas. The coal gas would cost 18 per cent. more than when the coke was sold and an enricher used, and your water gas 35 per cent. less, and your net cost 20 per cent. less than by coal gas alone, and 10 per cent. less than water gas alone.

I have tabulated the cost of manufacture in detail by these processes, basing my cost of coal gas partially on data taken from tables prepared by your worthy President, Mr. McMillin, and adopting exactly his form, as being just adapted to my purpose. (See tables, following page.)

I am bringing before you a subject with which you are all doubtless more or less familiar, and upon which most of you probably have formed strong and not altogether unbiased opinions, but will nevertheless endeavor to convince you of the advantages to be derived from the use of water gas. It is not enough that I can show a pecuniary advantage—we all know that, many times, the cheapest article is not the best; so here, though the gas may cost less by 20 per cent., it may be even more than that per cent. less valuable, and practically dearer. We must determine, then, the relative sales' value of these gases.

When we are investigating new processes as to their economy, we should examine the product of their manufacture both as regards its present and future uses. There is a field opening for gas destined soon to be a most important one—its use for motive power. The steam engine is a wasteful medium for power, and through it we can realize but a small

per cent. of the heat of fuel in work. We should, theoretically, obtain one horse power per hour from 0.17 pounds of coal; but the best results possible to obtain will be one horse power per hour from 0.66 pounds of coal. The average electric light engine will hardly reach one horse power per hour from 5 pounds of coal—or but 5 per cent. of the total heat is utilized. When this is considered, with the fact that the best dynamos will generate in electricity 85 per cent. of the power received, and in the arc light 12 per cent. of that power is given out in light—you see that the future success of arc lighting is dependent entirely upon a cheaper power for generating electricity. A gas engine will, theoretically and practically, transmit into power three-fourths of the heat in fuel, or you can attain to one horse power for every 4 cubic feet of gas burned in the cylinder of the engine. The best results so far obtained are 20 cubic feet per horse power per

The composition, by weight, of 1,000 cubic feet is given at—

Water Gas.		Coal Gas.	
Hyd.....	2.3	Hyd.....	2.3
CH ₄	10.0	CH ₄	15.5
C ₂ H ₄ , etc....	15.0	C ₂ H ₄ , etc....	7.2
CO.....	20.0	CO.....	6.0
N, O, and CO ₂ ..	3.0	N, O, and CO ₂ ..	3.0
Sp. gr.....	0.65	Sp. gr.....	0.48

Heat units per 1,000 cubic feet—

Water gas.....	820,000	Coal gas.....	730,000
----------------	---------	---------------	---------

The temperature of combustion with 20 per cent. excess of air would be—water gas, 4,800° F; coal gas, 4,580° F. Hence water gas has 12½

Table Showing Cost of Coal Gas per Ton of Coal, for 150 Million Cubic Feet Yearly Output.

Price per Ton Gas Coal.	Price per Ton Cannel Coal.	Yield of Gas in Cu. Feet per Ton.	Yield of Gas in Cu. Feet Cannel per Ton.	Tons of Gas Coal.	Tons of Cannel.	Candle Power.	Total Cost for Coal.	Cost for Purifying.		Cost of Retorts.		Wear and Tear.		Wages.		Aggregate Cost.		Net Cost by Each Process.		
								Per Ton.	Total.	Per Ton.	Total.	Per Ton.	Total.	Per Ton.	Total.	Per Ton.	Total.	Coal Gas.	Water Gas.	½ Coal Gas, ¾ Water Gas.
\$2.60	\$3.60	10,000	10,000	10,000	5,000	19.7	\$44,000	5 cts.	\$750	10 cts.	\$1,500	20 cts.	\$3,000	\$1.60	\$24,000	\$4.88	\$73,250	\$52,650	\$49,350	\$43,433

Table Showing Cost of Coal Gas per Ton of Coal, for 50 Million Cubic Feet Yearly Output.

\$2.60	9,000	5,550	17.5	\$14,430	5 cts.	\$278	10 cts.	\$555	20 cts.	\$1,110	\$1.60	\$8,880	\$4.55	\$25,253			
--------	-------	-------	-------	-------	-------	------	----------	--------	-------	---------	-------	---------	---------	--------	---------	--------	----------	--	--	--

Table Showing Receipts from Residuals for 150 Million Cubic Feet Yearly Output.

Weight of Coke from Ton of Cannel, in Pounds.	Weight of Coke from Ton of Gas Coal, in Pounds.	Weight of Coke Used and Lost.	Value of Coke Sold at \$3 per Ton.		Value of Coke Sold at \$2.50 per Ton.		Total Value of Coke Sold.	Value of Tar at 3 cts. per Gallon.		Value of Ammoniacal Liquors.		Aggregate Cost.		Net Cost.	
			Per Ton.	Total.	Per Ton.	Total.		Per Ton.	Total.	Per Ton.	Total.	Per Ton.	Total.		
1,300	1,300	520	\$1.17	\$11,700	58 cts.	\$2,900	\$14,600	30 cts.	\$4,500	10 cts.	\$1,500	\$1.37	\$20,600	\$3.51	\$52,650

Table Showing Receipts from Sale of Residuals for 50 Million Cubic Feet Yearly Output.

1,400	500	30 cts.	\$1,665	10 cts.	\$555	40 cts.	\$2,220	\$4.15	\$23,033	½ Coal Gas.	¾ Water Gas.	Total.
																\$23,033	\$20,400	\$43,433

Table Showing Cost of Water Gas per Ton of Coal, for 150 Million Cubic Feet Yearly Output.

Price per Ton, Hard Coal.	Yield of Gas in Cubic Feet per Ton Coal.	Yield of Gas in Cubic Feet per Ton Coke.	Price per Gallon, Naphtha.	Gallons Naphtha per Ton Coal.	Gallons Naphtha per Ton Coke.	Tons of Hard Coal.	Tons of Coke.	Total Gallons of Naphtha.	Candle Power.	Total Cost for Coal or Coke.	Total Cost for Oil.	Cost for Purifying.		Wear and Tear.		Wages.		Aggregate Cost.		Using Crude Oil.
												Per Ton.	Total.	Per Ton.	Total.	Per Ton.	Total.	Per Ton.	Total.	
\$5.00	40,000	3½ cts.	160	3,750	600,000	20	\$18,750	\$23,250	6 cts.	\$225	30 cts.	\$1,125	\$1.60	\$6,000	\$13.16	\$49,350	\$42,000

Table Showing Cost of Water Gas per Ton of Coal, for 100 Million Cubic Feet Yearly Output.

.....	40,000	3½ cts.	160	2,500	400,000	20	\$15,500	6 cts.	\$150	30 cts.	\$750	\$1.60	\$4,000	\$8.16	\$20,400	\$15,000
-------	-------	--------	---------	-------	-----	-------	-------	---------	----	-------	----------	--------	-------	---------	-------	--------	---------	--------	----------	----------

hour. In England, where gas sells at a low figure, very many of these engines are in use, and so it will be soon in this country.*

The use of gas for heating and cooking you are all familiar with, and so I need not touch upon it, except to say that our increase of revenue from these sources depends entirely upon our ability to manufacture and sell gas at low figures.

Thus you see that the gas of the future will have three distinct functions to perform—those of light, heat, and power. The gas that combines in smallest bulk, at least cost, all the requisites of these functions will be the cheapest and best to produce. The main requisites are heat units and temperature of combustion

* In the Paris Exhibition a Clerk gas engine was exhibited, running on a gas made by the Dowson process, showing a nominal horse power from 1.4 pounds of coal per hour.

per cent. more heat, and 5 per cent. higher temperature, volume for volume.

Again, perfection is rated commercially by the per cent. in amount of energy realized from that expended. How do these gases compare in this respect? Fifty pounds of hard coal and 28 pounds of naphtha are used to generate 1,000 cubic feet of gas. These contain 1,400,000 heat units, and the gas 820,000 units, or 59 per cent. From ½ of 1 pound of gas coal we obtain 5 cubic feet of gas; the coal contains 8,250 heat units, and the gas 3,600 units, or but 44 per cent.—an advantage in favor of water gas of 15 per cent.

My estimate, in tables, of the cost of water gas is based on using naphtha at 3½ cents per gallon. It has been practically shown that, on a large scale, crude oil can be used instead; and this would still further reduce its cost, as the crude oil, in this State, can be had at half the price

of naphtha. In coal works labor and wear and tear are elements of greatest cost, and remain the same per 1,000 cubic feet, regardless of quantity of gas made. The reverse of this is true of water gas, and I am informed that there are companies making water gas on a large scale, or from 1 to 3 million cubic feet daily, using hard coal and naphtha, at a cost 30 per cent. less than coal gas is figured in my tables.

Much has been written against carbonic oxide in water gas. We know it is poisonous, and alone, or with any non-odorous gas, dangerous to distribute; but with carburetted hydrogen can instantly be detected and all danger averted.

The same arguments that have been advanced against CO might be used against steam boilers. Who would wish to run a steam boiler without safety valve and pressure and water gauges attached? Should we, then, legislate out of existence all articles that may be considered dangerous; or should we pass laws compelling safety appliances to be used? Carbonic oxide is said to be a detriment to a gas, as it reduces its candle power. This may be true; but does not its presence add to the intensity of the heat of the flame? for we know that CO is the hottest of all gases. We attribute the value of hydrogen in a gas to its heat intensity; why not so of CO?

The specific gravity of water gas has been raised as an argument against it, on the ground that, in a large coal gas plant, the mains and service pipes would all be too small. There are but few large gasholders built that will not give an increased pressure of 25 per cent. over the pressure carried when delivering coal gas, and this increased pressure at the works obviates all necessity for increase of pipes or services, and will not make greater your leakage, as you may suppose; nor will it be detrimental to the burning of the gas.

The discovery of natural gas in abundance in this State brings up a new subject for gas men here to consider. What effect will the piping and general introduction of this gas into the larger cities and towns have upon the manufactured article? We have the history of but one city as our guide, and that is Pittsburgh. Since the introduction of natural gas there the demand for the manufactured article has steadily increased, and, owing to locality, they have continued to make gas from coal. Within the past year they have introduced processes for carburetting the natural gas. Not more than three weeks ago a water gas process was tested by the Messrs. Westinghouse for carburetting their natural gas, and the results obtained far exceeded their expectations, and fully demonstrated the feasibility of making a 20-candle gas from natural gas, at a very small expense for material used. No greater error can be made than to turn this gas directly into the lighting mains. The history of Findlay should be a lesson to all. We must carburet the gas and distribute it through separate mains.

The tests at Pittsburgh and other places show the water gas process to be the best in all particulars for carburetting natural gas; and I think you will agree with me ere long that it is the best gas for all purposes.

Discussion.

Mr. Lindsley—Do I understand that Mr. Christian also uses the coal process at Norwalk?

Mr. Christian—No. We use hard (or anthracite) coal at Norwalk, and make water gas altogether. We do not manufacture any coal gas. I recommend a mixture of the two as being cheaper in this State, as also in many parts of the country where good gas coal can be had. However, I believe someone has developed a new process for making water gas from any kind of soft coal, and have heard that the plan is meeting with very great success. I am not familiar with this last mentioned process, but understand that it has been highly indorsed, and that the results are very satisfactory. If such is the case, we could use any of the Ohio soft coals, and thus would not have to go to Pittsburgh for the prime material. I believe they coke the coal in the generator by some means or another.

Mr. Critchlow—I would be glad to emphasize the point made by Mr. Christian, near the close of his paper, with reference to the use of the crude oil obtained in this State instead of naphtha. As he suggests, that oil is to-day in use in a dozen water gas works that I know of, and it costs but one-half of the 3½ cents that he quotes as being the price per gallon for naphtha—quantity for quantity—yielding the same results.

The President—And no greater trouble to use it?

Mr. Critchlow—No, sir.

Mr. Bates—I understood Mr. Christian to say that, in accomodating small mains and services to the use of water gas, the addition of 25 per cent. in the pressure would not increase the leakage. I can hardly understand the statement. Much time and thought have been expended in decreasing our pressure (especially during the day time) in order to lessen our leakage. It is a well understood fact, I believe, that the

lower the pressure you carry, the smaller will be your leakage, which would seem to be directly counter to his assertion.

The President—It is owing to the different specific gravities of the gases.

Mr. Bates—But I cannot see that there is that difference in the specific gravity of the two gases.

Mr. Christian—There is the difference between 0.48 and 0.65, which, in 1,500, would be nearly 40 per cent.

The President—We have with us Mr. Burdett Loomis, of Hartford, Conn. We would like to hear from him.

Mr. Loomis—I did not come here prepared to say anything with regard to this matter—I am a builder of water gas works, and am disinclined to seek this sort of advertising—but have had considerable experience in the subject under discussion. The latest aim of those who attempt to improve the principle of water gas manufacture, has been to devise means whereby the use of anthracite coal can be superseded by the employment of a cheaper sort of fuel. In fact, only within the last year or so, have I been able to use bituminous coal in a practical way. They have all been at work on the problem of attempting to use cheaper coals, or those coals that were cheapest in the market in the places where the water gas was needed. Of course in this part of the country the shipping rate on anthracite coal makes it expensive. In my substitution experiments I succeeded in using slack bituminous coals for making water gas, and find that I can use the cheapest of your slack coals and get as great yield per ton from them as from any quality of anthracite coal. Of course the slack would need to be sound, for a dirty or slaty article is worthless. Any slack, no matter how fine, provided it consisted of pure coal particles, would yield as large a quantity of gas as though an equal weight of anthracite was used. In that way the cost of the gas is largely reduced in many places. As is well known, coal can be bought in this State (Ohio), 50 cents per ton upwards, according to the propinquity of the market. It, therefore, becomes an object to make fuel gas from this slack coal, to be distributed for manufacturing purposes and for running gas engines. Mr. Christian, probably, referred to the Dowson process for manufacturing producer gas, when he first spoke during this discussion. The Dowson producer gas (it contains about 30 per cent. of combustibles) is used, I am told, very successfully in England to move large gas engines. It is asserted that from its use in gas engines, they obtain 1 horse power at the equivalent of an expenditure of 1 to 1½ lbs. of coal. In this country we ought to be able to do better, for, from our slack coal we can, under the water gas process, make a gas that will carry from 60 to 70 per cent. of combustibles, and secure a gross yield about equal in quantity to that obtained by Dowson.

The President—I scarcely understand how you can get as great a yield in feet from the coal, when the product carries 60 to 70 per cent. of combustibles as when carrying only 30 to 35.

Mr. Loomis—In the crude way in which the Dowson gas is made, he does not get that per cent. Owing to the crude manner of its employment, more air than that needed to take away the gas is supplied. It should be controlled; and if controlled properly, even more producer gas can be made from a ton of coal than by any other process yet devised.

The President—In producing gas, of course, the more air they use the more heat they get.

Mr. Loomis—If you pass in too much air you get an excessive proportion.

The President—But, nevertheless, it is heat that you desire.

Mr. Loomis—If the supply of air to the producer gas is properly controlled, the mixture possesses a greater number of heat units, although the bulk or quality of gas available for work is decreased, than if the contrary practice prevailed.

The President—But you said that they (the Dowson folks) would get more heat if they used the ordinary water gas process. You mean, more heat units, not more heat?

Mr. Loomis—Yes.

Mr. Graeff—What process is being put up in the works of Messrs. Disston, at Philadelphia?

Mr. Loomis—A process for making a mechanical mixture of producer gas and water gas.

Mr. Monks—This is a subject which has interested me greatly, and I am glad that the time has come when this subject can be introduced at a convention of this kind, without the suspicion that the party so introducing it has a patent interest, or something of that sort to dispose of. Perhaps the bad name hitherto possessed by water gas, was because the original promoters had been guilty of such practices. Now, that water gas has been introduced, in one shape or another, in perhaps 33 per cent. of the gas works in this country and Canada, it is a fair subject of

inquiry and discussion as to how far it is useful to us; how many works there are that can afford to dispense with it altogether—the number of the latter is legion, for there are many coal gas works that could not possibly do their work any more efficiently—how many works it would be an advantage in; and as to the relative cost and merits of the two gases? This subject has excited a great deal of interest in Massachusetts, in various ways; and it is a subject that we should dispassionately discuss on its merits. We have to consider the advantages and the disadvantages—the relative cost; the danger of the gas (if there be any) to human life—and then determine whether we want it or not. Mr. Christian's paper relates largely to the cost of the two gases, and, therefore, I will confine my remarks to that branch of the subject. There is no doubt that when the gentleman who now stands as chief engineer at the head of the Consolidated Company of New York city—Mr. Bradley, who is an engineer of acknowledged ability—first took up the water gas process, and could buy his naphtha at three cents per gallon—coal was higher then than now—that that Company (the Municipal) made money very rapidly. He did another good thing—the first good thing in that line that was done in the water gas business. He followed out the principle that anything in this world that was worth doing at all was worth doing well. A great many of the troubles that came out of the manufacture of water gas, resulted because people who were speculative, or who wished to infringe upon the territory of some company in selling rights to manufacture water gas, put in plants that did not do the work they ought to have done; and this has been a discredit to the water gas business. But Mr. Bradley built works that were complete in every detail, and turned out a gas which always ranked high and stood well. When he bought his naphtha at three cents per gallon, he was undoubtedly working at a tremendous leverage of advantage over the coal gas companies of New York city, whose managers were paying a higher price for their naphtha, and, perhaps, at that time, \$7 or \$8 per ton for gas coals. But, so far as the price for material is concerned, the inevitable law of supply and demand has prevailed in this matter. A person who has an article to sell, does not long continue to sell for \$1 that which is worth \$1.50, and the result is that after careful inquiry in our State, and also in other States, I am convinced that the relative cost of the two gases put into the holder is to-day practically the same. This a change from what it was originally, or when naphtha was a waste product, and when the Standard Oil Company, and other refiners as well, would sell naphtha at the purchaser's bid. Apart from this, however, it seems to me, after investigation of the subject, that the gas works of the future (in the large cities at any rate) ought to be equipped to make gas either way, so as to practice the economies that come out of the two. Among the advantages of having a water gas plant in large cities, is the fact we can rely upon it in case of a strike. It certainly is much easier handled, and it would be very much easier to keep up the supply in a city or town where such a state of things existed. We can use it where—as there is in some of the towns and cities of our commonwealth—a bad market for coal tar and coke. In my opinion, although I may claim to be the author of the law by which water gas was shut out from our State, that law should not be allowed to remain in force. In your State the same question comes in; and although perhaps nine-tenths of you gentlemen are manufacturers of coal gas, you have no antipathy to a man because he is a manufacturer of water gas, and you have no desire that his business should be in any way suppressed. But it has come to pass with us in Massachusetts that a little Company at Athol, which were never, under the old process (being a long way from tide water, and coal costing high prices), able to pay a dividend, since they have put in a small water gas plant, have been able to earn a profit, pay a dividend, pay interest on their bonds, and to satisfy the community. In fact, the three Selectmen of the town who were qualified to collect the fine imposed under our statute for supplying a gas with an excess of carbonic acid refused to do so, and indorsed the new gas as superior in illuminating power to that which was formerly supplied. We are also in a most peculiar position in Massachusetts in respect of that law, because a fuel water gas containing 50 cent. of carbonic oxide can be supplied, while a gas containing only 10 per cent. cannot be supplied for illuminating purposes. Under that law the gas consumers have taken up this matter, and the Attorney General of the State has notified the Athol Gas Company, that unless the process of coal gas manufacture is again resorted to in the works, he shall move in the courts to have the establishment shut up. I say, in the interest of fair play, that that law stands in the way of progress. I understand that some of the companies in this and adjoining States are about putting in auxiliary water gas plants. I have said that, in my judgment, where such a plant is put in, either as auxiliary, or to do the whole work, that it should be well erected. One of the troubles developed in Worcester at the first hearing had before the Gas Commis-

sioners of Massachusetts, has demonstrated to my mind the necessity in all cases of a relay holder. In combination works, where coal gas is being made continuously, and where the ordinary apparatus for purifying and preparing it for market are in use, the plan often is to suddenly inject a very large amount of water gas (for water gas is made very rapidly) into the purifiers, and thus create a certain amount of back pressure on the exhauster. That has a good many disadvantages. While I do not feel it would be proper for me to go into that, I simply make the suggestion that, if in future, the coal gas works in this neighborhood, or such of them as would find an advantage in a complete or auxiliary water gas plant, should put in such a one, is one essential feature which in my own case thus far has been left out.

The President—I see the face of a very good looking gentleman from Philadelphia—Mr. Goodwin; will he speak to us?

Mr. Goodwin—All of us fellows from the East, and particularly those of us from New England, are considered to be very modest men. Being of that kind and class, I do not know that I ever made a speech in my life; but as the Dowson apparatus has been mentioned, I would like to make a remark or two about it. As I had the good fortune to see it in operation in Europe (in Paris) in 1881, when visiting the Electrical Exhibition of that year, I will endeavor to illustrate the construction of the apparatus. It is composed of a cylinder, say about 2 feet in diameter and 2½ feet high, supported upon a base, say about 15 inches in diameter, and in which there is a door. This small cylinder has a base, which supports the large cylinder upon the ground. At the intersection of the small with the large cylinder is placed a grate. The inside of the large cylinder is lined with fire-clay, or other material of that character, cone-shaped, flaring to the top. Below the grate a small tube, about ¾ inch in diameter, is screwed into the smaller cylinder, projecting out a foot or more from the side. The top of the cylinder is covered with a plate secured by bolts around a flange at the top of the cylinder. On the top of this plate is placed a hopper, with a valve so arranged that, upon pouring coal into the hopper, and closing the lid on the latter by a movement of a lever attached to the valve, the coal is dropped onto the incandescent coal in the vessel. A suitable pipe is connected with the top of this large cylinder for carrying off the gas.

Alongside of the apparatus just described is placed a coil of ¾ or 1-inch pipe, coiled upon itself several times at right angles. This coil is placed in a small brick furnace. At the lower end of the coil coming out of the furnace is attached a small pressure gauge; the end of the pipe terminates with a valve, on the end of which there is a small jet. This jet is placed so as to first enter the piece of pipe at the base of the large cylinder already referred to. The end of the tube entering the furnace, if convenient, is attached to a boiler, and a proper amount of steam is allowed to pass through this coil, which is superheated by either a small fire placed under the coil pipe, or by a properly constructed burner supplied with gas from the apparatus. Should there not be a boiler for steam at hand, a small quantity of water is allowed to pass through the coil and the heat of the furnace turns it into steam. The apparatus thus described is put in use as follows:

The lid of the hopper is raised and the valve of the same lowered by elevating a lever. Shavings and kindling wood are passed through and fall upon the grate; a sufficient quantity having been placed there, the fuel is lighted by opening the door in the smaller cylinder or base, and, by an arrangement on the top for turning a valve, the smoke and products of combustion pass out of the vessel. When the wood has been sufficiently ignited, coal is then poured through the hopper in sufficient quantity to fill the vessel about one-half full. After it has become thoroughly incandescent the flue is closed, the lower door being closed by a bar placed across it and then screwed up. Steam is then turned on from the small furnace and, passing through the small pipe referred to, enters under the grate and up through the incandescent coal, resulting in the production of the Dowson gas, which is carried off, by the pipe already referred to, to a gas holder.

The apparatus referred to will make about 1,000 cubic feet of gas per hour. Coal is frequently introduced through the hopper, so that the apparatus is practically continuous.

The gas is used by the Crossley people, of England, for running their gas engines. The gas is sometimes passed through a scrubber. I trust that I have made myself clear with this crude explanation.

The President—Is it necessary to purify the gas in any way in order to work it in an engine?

Mr. Goodwin—As already stated, a small scrubber may be used for that purpose. Dowson was over here a few years ago, and tried to get people interested in it. He wanted me to organize a company, but, upon reflection, I did not feel that I could afford to do that as it would be in opposition to the gas interests. I only desire to give you the facts—that

the thing is in existence—that we have one at the factory, and I will be pleased to show it to any gentlemen who want to see it.

The President—I think the stenographer's notes will show that Mr. Loomis, in answer to a question regarding the process being put in by the Messrs. Disston, said it was virtually the Dowson process. Now that we have had the description by Mr. Goodwin we know what he referred to.

Mr. Loomis—I may add that the coal will also *make* the Dowson gas. You may let the steam in with air; but when you put the steam in in this way it is cooled down, and must be heated up again by the incandescent coal. The Dowson gas is practically the Siemens producer gas. That is just what any producer gas, air being passed through the coal and the hydrocarbons being taken off, is. Of course, in the Siemens producer gas, and also in the Dowson gas, whenever that plan is followed they are troubled with the tar. In my way of making producer gas I do not have the tar, for the tar is carried to such a heat that it is gasified. What heavy carbon is contained, or that will not gasify, is burned, and is used in heating up the apparatus ready to make water gas. When the coal is in a perfect condition to make water gas it is at incandescence. You cannot make carbonic oxide and hydrogen gas unless your coal is in a perfect state of incandescence. As soon as it cools down it goes off as carbonic acid, and is a detriment to your gas. When the apparatus has evolved its producer gas, and has reached incandescence, I reverse the motion, pass steam through it, pass that product into the same pipe, and the two are mixed. The apparatus is in sections, so that one will be running water gas while another will be running producer gas, the two sorts being mixed in the same apparatus. In this way I make a richer and better quality of gas. Perhaps I get a few thousand feet less per ton of coal, but am able to get more heat units out of a given number of thousand feet than in any other way.

The President—Then if we evaporate from our ashpan, in the regenerator furnace, all the water that is going in which will decompose, without cooling down below the point of dissociation, we are making the Dowson gas.

Mr. Loomis—The steam that goes through would make a water gas. If the coal under your retorts is incandescence, then all the air that goes through would make Dowson gas.

The President—Then we are making Dowson gas in our regenerator furnaces whenever we decompose all the steam without cooling below dissociation?

Mr. Loomis—The way to make that is to set the producer at one end of the retort, put all your coal at the other, and carry it where it is wanted.

The President—We can make it cheaper than that when we need it.

On motion of Mr. Huntington a vote of thanks was tendered to Mr. Christian.

The President here left the chair, and Mr. Huntington presided during the remainder of the session.

ELECTION OF OFFICERS.

The report of the Committee appointed to nominate officers having been again read, the Chair appointed Messrs. Butterworth and Bates to act as tellers, who subsequently reported the result. The President thereupon announced that the following gentlemen had been designated to act as officers of the Association for the ensuing year:

President—Eugene Printz, of Zanesville.

Vice-President—J. Gwynne, Fostoria.

Secretary—Irvin Butterworth, Columbus.

Treasurer—E. C. Gwyn, Springfield.

RESPONSE OF PRESIDENT PRINTZ.

The President said they would be pleased to hear from their future ruler. In response, President-elect Printz said: Mr. President and gentlemen, I can hardly say whether I ought to thank you for this honor or not. I certainly hold it to be an honor, but at the same time I feel very diffident about accepting the position, particularly when I remember that I am to follow the footsteps of the able Presidents who have held the chair. However, I shall do the best I can, and hope, with your assistance, to satisfactorily perform the duties of the office. (Applause.)

NAMING PLACE OF MEETING.

Mr. Wood of Committee to designate place for holding next annual meeting, reported that the Committee had unanimously decided to name Sandusky as the city wherein to hold the Fourth Annual Meeting. The recommendation was ratified.

IN MEMORIAM.

The Committee appointed to prepare resolutions in regard to the death of Mr. J. Anderson, late of Ironton, presented the following report,

which was read by the Secretary, and, on motion, adopted by a rising vote:

WHEREAS, In view of the loss we have sustained by the decease of our friend and associate, J. C. Anderson, and of the still heavier loss sustained by those who were nearest and dearest to him; therefore, be it

Resolved, That it is but a just tribute to the memory of the departed, to say that in regretting his removal from our midst we mourn for one who was, in every way, worthy of our respect and regard.

Resolved, That we sincerely condole with the friends of the deceased on the dispensation with which it has pleased Divine Providence to afflict them, and commend them for consideration to Him who orders all things for the best, and whose chastisements are meant in mercy.

Resolved, That this heartfelt testimonial of our sympathy and sorrow be forwarded to Miss M. J. Seymour, of West Hartford, Conn., the affianced of our departed friend, by the Secretary of this Association.

R. H. CANBY,
GEO. H. TAYLER, } Committee.
WM. McDONALD.

AS TO CHANGING TIME OF MEETING.

Mr. Wood—I would like to secure an expression of opinion from the members as to the best time for holding the annual meeting, and whether they would like to postpone it until a month later. Thinking many of the members prefer to have it so, I ask an expression from them as to the advisability of making the change.

The Secretary—I have not the Constitution at hand, but am confident that it is provided by the By-Laws that the regular Annual Meeting of the Association shall be held on the third Wednesday of March.

Mr. McMillin—Originally we put it in February. The idea was to get a time for holding it when the gas men would not be very busy. Their consumption is then on the down grade, and so we fixed it for that month; but, unfortunately, we fixed it on the same day with the Annual Meeting of the New England Association; and as New York could not spread herself over New England and Ohio at the same time, we changed our meeting to March. April would be a much pleasanter month to me in which to hold our meeting, but the Western Association, an older organization than ours, meets in May, and probably 33 per cent. of the members of this Association belong to that Association also, and attend its meetings. We feel that it is coming a little too close together to attend the meeting of the Ohio Association in April, and that of the Western Association in May. Personally I greatly prefer April to March, but think it would be a mistake to make the change as long as the Western Association continues to hold a meeting in May. Further, I do not know that we could change it if we wished.

The Chairman—I do not think the change can be made without a modification of the By-Laws. If there is no motion looking to a change of the By-Laws in that respect, the meeting will be held as provided for, in March, 1888.

VOTES OF THANKS.

Mr. Printz—I wish to move a vote of thanks to our worthy President, Mr. McMillin, for the uniform courtesy and dignity with which he has presided over our deliberations at this meeting, and for his attention to the interests of the Association during the past year.

Mr. Hamlin—I offer an amendment that the rest of our officers be included in that expression of our thanks.

Mr. Printz—I accept the amendment.

The Chairman—You have heard the motion—which I put with great pleasure—that the thanks of the Association be extended to the officers who have so faithfully served its interests during the past year in discharging the duties which they have so well performed.

The motion was unanimously adopted by a rising vote.

Mr. Hamlin—I think, when I say that this has been a very enjoyable meeting, I speak the feeling of every member here, and as we know that our friends, the Dayton Gas Light Company, have liberally contributed, not only mentally but bodily, towards our pleasure, I, therefore, move that a vote of thanks be tendered them for the very hospitable treatment we have received during our stay here.

Mr. Gwynne—I second that motion, most heartily.

Mr. McMillin—Let us have a rising vote on that.

The Chairman—My pleasure increases as I put these motions. You have heard the motion, and we will vote on it by rising.

The motion was unanimously adopted.

Mr. Diekey—Mr. President and gentlemen I am very much obliged to you, one and all, for the compliment. We have tried to do the best we could, and hope you have all enjoyed yourselves.

The Chairman—The Chair takes great pleasure in saying that as friends and entertainers you are unsurpassed.

The Association having accepted the invitation of Mr. Diekey to visit the Dayton Gas Works, the business sessions were declared adjourned.

The Relation of Coal Dust to Mine Explosions.

Some time since Mr. S. M. Buck, of West Va., called the attention of the Massachusetts Institute of Technology to the above subject. In his paper the author said:

Fire-damp is a mixture of gases, varying at different places, and consisting principally of light carbonized hydrogen, or marsh gas, but also containing some carbonic acid, nitrogen and other hydro-carbon compounds, with a specific gravity of only 55 per cent, as compared with atmospheric air. It is generally without odor, taste or color, and burns, when pure, with a yellow flame. It is not poisonous, and can be breathed when forming one-third of the air. On account of the low specific gravity, it collects most readily near the roof of the mine, but speedily mixes with the air through diffusion. It is detected, when in small amount, by its effect on the flame of the safety lamp: 2 per cent. is the smallest amount that can be detected with an ordinary lamp, the flame increasing in length and size with the amount of gas. The mixture first becomes explosive when there is 8½ per cent. of gas: it is most explosive at 16 per cent.; and at 18½ per cent. it ceases to be explosive and extinguishes the light.

The peculiar principle of the safety lamp was discovered, in 1815, by George Stephenson, and also by Sir Humphrey Davy. This principle is, that the enclosing wire gauze so far cools the burning gas within, that the flame does not communicate with the surrounding explosive mixture. This is true so long as every lamp is in perfect condition, and there is no sudden movement of the air or carelessness.

In order to dilute the percentage of fire-damp to the least possible amount, centrifugal fans have been used, giving a ventilating current of 150,000 up to 250,000 cubic feet of air per minute.

Fire-damp is not found in all mines, and many parts of our own country have so far been considered entirely free from it. Miners generally contend that drift openings are not liable to fire-damp, but this is not so, and with each year's more extended workings the danger increases.

Loose coal gives off gas constantly, so that the more coal is loosened from day to day the greater the danger. If the mine is allowed to stand a few days, the percentage of fire-damp decreases. There is also an increase of fire-damp with any lowering of the atmospheric pressure. In fiery mines there is a liability to sudden outbursts of gas called blowers, and against these it is hard to take precautions. Since the phenomena of natural gas have been studied these outbursts seem less strange, though perhaps no better understood. It is interesting in this connection to note the experience of the Prussian fire-damp commissioners, that the mine gas proves most abundant when the coal is folded on an anticlinal axis not reaching the surface and accompanied by a porous sandstone overlaid by clay slate. This is especially true where the drainage has removed the water and increased the porosity of the sandstone.

The influence of coal dust in colliery explosions was first noticed by Lyell and Faraday, in 1864, and it was recognized as increasing the force of gas explosions. In 1876 Galloway showed by experiment that, while more than six per cent. of gas alone was required to make an inflammable mixture with the air, less than one per cent. of gas was required in the presence of fine coal dust.

Further experiments between 1879 and 1881, led Galloway to believe that an explosion produced by a local occurrence of fire-damp might be indefinitely extended in an atmosphere loaded with coal dust.

In 1874 a paper was read before the North of England Institute of Mining Engineers, by Messrs. Hall and Clark, showing, as a result of their experiments, that the presence of fire-damp was not necessary, but that a blown-out shot in the presence of fine coal dust would cause an explosion. In coal mining a blown-out shot is one where the tamping is blown out by powder without any decided action on the coal, and the effect is much the same as though a cannon were fired in the same position. The force of the powder is expended in projecting the current into the air of the mine and stirs up any dust that may be present. At the same time it is thought by many that the partial vacuum succeeding a blown-out shot tends to draw the gas from the coal more rapidly than would otherwise be the case.

In the course of the investigations following the Seabank colliery explosion in England, in 1880, it was further shown that the fine dust, which in itself was entirely incombustible, had a distinct effect in explosions and made dangerous a low percentage of gas, which of itself would be quite harmless.

In 1883 it was generally admitted by all who had given special attention to the subject that all gas explosions were more violent in the presence of fine coal dust, and that dust would render explosive a mixture of air containing two per cent., or possibly as low as one per cent.

of fire damp. But Mr. Galloway was looked upon as an enthusiast, if not a crank, and his claim that coal dust alone could lead to an explosion in the absence of gas, found little credit. About the same time a Government commission was appointed in France to examine the same subject, and they reported that dust in the absence of gas was not a cause of serious danger.

Partly owing to Mr. Galloway's paper and partly to the renewed attention called to the subject by certain flour-mill explosions, the matter was taken up again in Prussia, and intrusted for investigation to one section of the Prussian fire-damp commission which first met in June, 1881, and made its final report in November, 1885. The experiments were made in a gallery of elliptical form, 5 feet 7 inches by 3 feet 11 inches and 167 feet long, so arranged as to give a chance for observation without danger to life or limb. The speaker gave a detailed description of the manner of conducting these experiments and the results of a number of the experiments.

Over 400 such experiments were carried out with the greatest care, and the results were well established.

The most important deductions are as follows:

1. That with certain classes of coal dust an actual explosion, extending beyond the limit of the dust deposit, may be caused by a blown-out shot, even when fire damp is entirely absent.

2. That while the finest dust is usually the most dangerous, the chemical composition of the coal is more important, and that a volatile percentage of from 16 to 24 is the most dangerous.

3. That a 3 per cent. gas mixture, in the absence of scattered gas, causes no danger in case of a blown-out shot, even though tamped with the most dangerous dust, and that a 6 per cent. mixture is required for actual explosion.

4-5. That dust in pure air cannot spread a flame from a lamp alone; that fire-damp up to 3½ per cent., without dust, only lengthens a lamp flame; that at 4 per cent. the flame begins to slowly spread at the rate of one foot per second, and that at 6 per cent. the speed is six feet per second, and incipient explosions take place. Let dust be present, and explosions may be started by an open lamp with only 5 per cent. of gas.

6. That for insuring safety, the dust must be wet down with 50 per cent. of its weight of water—not simply moistened—and that this must be done for a space of 30 feet back from the face of the coal.

7. That the Davy lamp as a test for gas is only to be trusted from 3 per cent. up, but that the Pielar lamp can be relied on for detecting one-half per cent. of gas and for estimating mixtures of from one to three per cent.

8. That the time required for the full, natural diffusion of fire-damp in a mine gallery of ordinary size is from three to four hours.

These are the principal points settled by the Prussian commission, and it is of interest to us to consider if the subject is to be looked at as practical or only as theoretical. In other words, have we ever had, or are we likely to have, a coal dust explosion in this country?

The explosion at the Pocahontas mine, which occurred March 13, 1884, was by many persons regarded as a dust explosion, even at that time, and as more light has been thrown on the subject, that theory has gradually received more favor.

The "Richelieu" Coke Stove.

The *Journal des Usines à Gaz*, in calling attention to the value of coke as an agent for domestic heating, and referring also to its popularity in that direction in Paris, France, says:

For some years past the use (in France) of stoves for heating various rooms in residence buildings has become quite general. More particularly perhaps does that observation apply to Paris, for there a complete transformation has been brought about in the old-time practice of heating apartments: and we are glad to say that the increase in the number of movable stoves has been accompanied by an effort on the part of stove makers to keep pace with the demands of the users for new and improved styles of apparatus. While we cannot say that any really new principle has been developed in the stoves, nevertheless their foremost features perhaps do not admit of any great advance in essential details of construction: and possibly we need not look for such, because it would seem as if the acme of adaptability had already been reached. When to that we add that they permit of cleanliness of service, and secure great advance in the important item of economy in the consumption of fuel, we naturally, in making a selection, must incline to the idea that the simplest form is the best, and that cost alone becomes the sole factor in determining a purchaser as to which sample he shall buy.

Those styles whose prime feature is the heating of the air, and in which a space is reserved for a door beneath the fire grate, are disadvantageous,

in that the capacity of the fuel chamber is diminished, and also present an opening for the passage of fine dust, thus necessitating an amount of disagreeable and exacting attention or care.

The arrangement of the parts pursued by Chouberski seems to accomplish the best result, and all the valuable features of his plan are to be found in "The Richelieu" stove, as manufactured by M. M. Moret, Dard and Deschamps.

The following illustration will with sufficient clearness convey to our

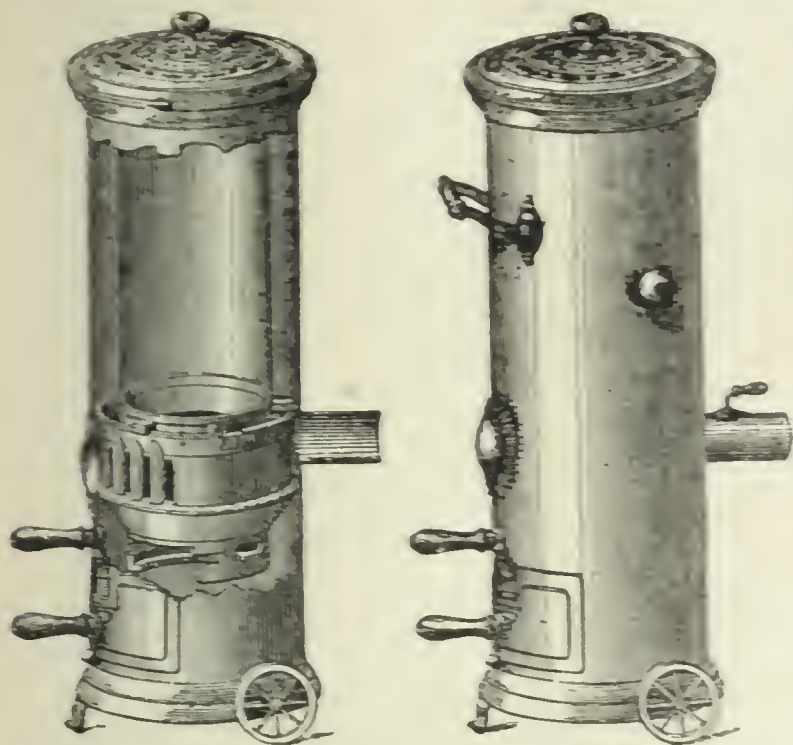

readers all the leading details, without any minute description on our part. It is so simple in working that a few moments' thought will enable anyone to manage the apparatus.

The preliminary fire having, by means of a few chips and a handful of charcoal placed underneath a thin layer of coke, been started, the fuel chamber may be completely filled. No further care need be bestowed upon it save, of course, once or twice during the day to refill the coke receptacle, the frequency of that attention being governed by the size of the stove. One shaking of the grate will free the draught. By following these simple directions an ordinary room may be kept at an even temperature for months at a time.

From personal observation and experience we have reached the conclusion that the movable coke stove furnishes the most economical solution of the problem of how to heat Paris apartments. The specimen or sort made by M. M. Moret, Dard and Deschamps adds, to excellent quality of construction, the great advantage of cheapness in price; and, because of that combination, we believe it to be a most useful device.

Translated for the JOURNAL from the *Journal fuer Gasbeleuchtung*, by "A. S."

Has the Length of the Photometer Bar any Influence in Determining the Results of the Observations?

By D. COGLIEVINA, C.E., Vienna.

We are of the opinion that Dr. Kruss, through merely proposing the above question, has done a great deal toward arriving at the so generally desired solution of the photometrical problem, even in case (as is the actual fact) that the results obtained by him during his researches by no means complete those deductions which are necessary for the material improvement of the present method of measurement of light. In the province of scientific research it is often incomparably more necessary to discover a source of error than to find the proper means to avoid the mistakes arising therefrom; or, as in the present instance, to plainly expose an error of long standing than to place in its stead a new and correct law—just the same as it is sometimes not so very difficult to combat a

* TRANSLATOR'S COMMENTS.—I believe Herr Coglievina is in error in the matter of infiltration of air into gas mains under pressure. No doubt, the longer the bar the more exact will be the results, providing there is light enough thrown upon the disk; yet, to take proper readings, neither can the employment of an excessively broad (or long) flame lead to exact results. In this connection, however, I think the author errs in preferring the Argand to the barwing simply because its flame is not so wide, because its flame is, on the other hand, a great deal longer, and its extreme points are probably just as far distant from the optical axis in a vertical distance as those of the barwing in a horizontal one. I also think that the diameter of the transparent part of the disk, as compared with the size of the luminous zone of the flame, will make some difference.

disease once it is thoroughly diagnosed, for it is always a much more severe task to trace its true origin and its peculiarities.

That much said in advance, we beg leave to take up the interesting conclusions of the above-named specialist in rotation, as follows: First—in regard to the instance which called for an examination into the above question; second, in relation to the manner of examining circumstances connected therewith; and, third, with reference to practical photometry.

I.

The instance before us is of rather infrequent occurrence. As far as we know, wherever there is any regular form of agreement for the supervision of the gas supply between the town authorities and the gas company, such supervision is based upon observations on or from instruments of the same make and system. This mutual sameness in the methods of observation seems fully justified, not only in view of the matter of expense, but also because it is desirable to have the results agree.

In connection with the first point, the matter of expense, we can imagine only two methods—either the cost of the necessary apparatus is borne by the gas company alone, or by the two contracting parties in even share. Since, in either case, the observations should be equally trustworthy, and it would in consequence be at least unjust to bind the one party to equip itself with a comparatively better instrument, leaving the other at liberty to consult in this matter its own pecuniary interests, there appears no good reason why different photometrical apparatus should be used at either of the two photometrical stations.

In relation to the exactness of these observations, a statement of the reasons why two photometers of the same system, but of different lengths of bar, must necessarily give results of unequal trustworthiness need not be discussed here now, especially as this matter has been thoroughly ventilated by various competent men during the past few years. Whether, then, scientific or financial reasons have prevailed at the selection of the photometers, due regard for justice, and for the exactness of the observations as well, would call for even application of the former in either case.

In the instance at hand, many will probably share our astonishment that the interested parties have kept up for years (and seem to keep up yet) a state of affairs which, at best, could create only mutual dissatisfaction, when it could so easily have been remedied by abandoning one of the two photometers. In this connection we may as well say at once that, according to our understanding, even the introduction of apparatus of similar build would not prevent the occurrence of small differences in the results at any place where, as here, the observations are taken at stations so far apart. Thus, for instance, we find from the respective reports of Vienna that the observations at the various gas works generally show an average illuminating power of 14.5 candles, as against 14.75 candles obtained at the City Hall, notwithstanding the fact that all these places are equipped with the identical kind of apparatus—the Evans' modification of the Bunsen photometer, of 100 inch length of bar.

For a simple or clear explanation of this we would only refer to the fact that at the works we are ever dealing with freshly manufactured gas, it being an easy matter to blow any stale gas out of the short connections; when at the City Hall the gas which has remained stagnant all day in the main system has to be used. Though we are well aware of the fact that the gas diffuses very rapidly, and that the gas in the mains is the average of various periods of production, we are still of the opinion that the mixture of gas thus obtained cannot, by loss of illuminants during its long passage, as well as by admixture of air through unavoidable defects in the mains, have the same quality that it possessed at the point of production. For this reason provision is made, in most contracts for the supply of gas, that observations should be taken in periodical rotation at points in the outskirts (the gas works), and again nearly in the center of the town (the City Hall), evidently with a view of thus determining, as closely as possible, the real illuminating value of the gas. That, in opposition to this very clear meaning of the contracts, the proper rotation is occasionally not observed, but an absolute value given to each separate observation, can hardly be charged against the contracts themselves, nor could it be stopped by the introduction of more expensive apparatus. In such a case the question might be asked, "Why should there be such a double supervision, since, as long as the average of the two observations is not to be accepted, neither of the two values should be held to represent the true illuminating power?"

Although, according to the aforesaid, there is no reason for the contracting parties to blame one another for differences in the results, which differences are perfectly natural, it is still a matter of congratulation that this case has induced a gentleman, of the standing of Dr. Kruss, to ex-

amine the matter thoroughly and obtain important results, instead of being satisfied with the most plausible explanations, or such as we have advanced above. His examination has furnished undeniable proof that the length of the photometer bar has a direct bearing upon the results of the observation, or that, with a decrease of the distance between the disk and the source of the light to be measured, there is also a decrease of the observed illuminating power, and thus that the latter decreases with the shortening of the bar.

II.

Dr. Kruss arrives at this important conclusion from a series of mathematical operations based upon considering the fact that those parts of a flame which are situated sideways from the optical axis throw less light upon the center of the disk than those parts situated in the line of that axis; so that the light thrown upon the disk is necessarily the less the larger the spread of the flame in proportion to its distance from the disk. If, therefore, J denotes the intensity of a given flame, R the distance between flame and disk, and H the light thrown upon the disk, then H is no longer equal to $\frac{J}{R^2}$, as has been heretofore accepted, but this value has yet to be multiplied by a factor $K < 1$. This factor, K , clearly depends upon the size of the angle, α , formed by the extreme rays with the optical axis, and, according to Dr. Kruss, is—

$$K = \frac{\frac{2}{3}\alpha + \frac{1}{3}\sin 2\alpha + \frac{1}{3^{\frac{1}{2}}}\sin 4\alpha}{\alpha}$$

The correctness of this equation cannot be questioned in any way, yet we would like to avoid using integral calculus for figuring out its value, although its application for solving this problem becomes a necessity where the utmost exactness is desired. Still, experience teaches us that the application of such results is generally neglected just where they should prove their real value; that is, in daily practice. Taking this into account, we think it proper to base these deductions upon generally known laws and easily accomplished ways of calculation, and to be satisfied with results thus obtained which, though theoretically somewhat less exact, are practically correct enough.

In this direction we have tried to obtain, by using elementary methods of calculation, a simple formula, which, used in lieu of the above one, should express as exactly as possible the relations in question.

We arrived at it by the following process of reasoning: If there is in A a source of light, of the intensity i , spread equally along the diameter,

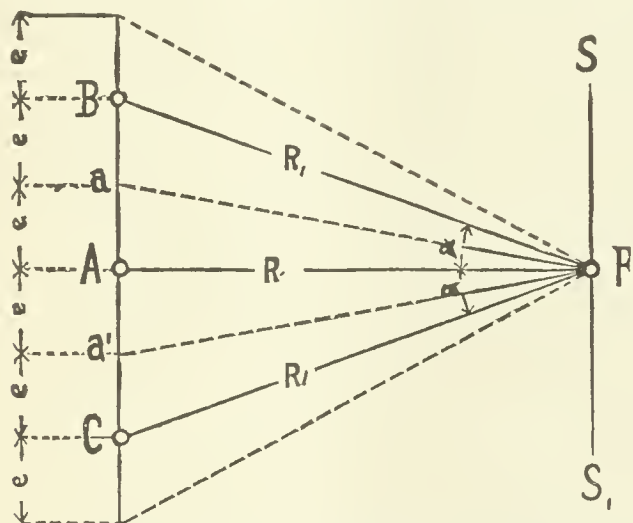

$2e$, and if e may be assumed to be infinitely small in proportion to the distance, $AF=R$, between the light and the disk, SS' , then, as far as exactness necessary for practical purposes is concerned, no great fault will be committed by regarding this intensity, i , concentrated in A instead of spread over a zone of the diameter aa' , and consequently as operating upon the point F in a perfectly normal way. The light at this point F is, then,

$$h_1 = \frac{i}{R^2}$$

Assuming another source of light, of the same intensity, i , established at the point B , it will produce, at the point F , a light

$$h_2 = \frac{i}{R_1^2} \times \cos \alpha$$

But we have $\cos \alpha = \sin (90 - \alpha) = \frac{R}{R_1}$, and, further, $R_1^2 = R^2 + e^2$, and $R_1 = \sqrt{R^2 + e^2}$; consequently,

$$h_2 = \frac{i}{R_1^2} \times \frac{R}{R_1} = \frac{i + R}{(R^2 + e^2) \sqrt{R^2 + e^2}}$$

A light h_3 will also be thrown upon F from a third source, located at point C . The total light at point F is, then, expressed by the equation—

$$H = \frac{i}{R^2} + 2 \frac{i \times R}{(R^2 + e^2) \sqrt{R^2 + e^2}}$$

or, if $i = \frac{J}{3}$ is substituted, then

$$H = \frac{J}{3} \left[\frac{2R}{(R^2 + e^2) \sqrt{R^2 + e^2}} + \frac{1}{R^2} \right] \dots \dots \dots (1)$$

In contrast to the proportion $\frac{J}{R^2}$, which is at present commonly used in photometry, and which naturally, when calculated, must give a light inferior to that which is actually reflected upon H , because it considers only the action of the rays in the line of the axis, our new formula takes besides this into account, as far as necessary for practical purposes, the action of those rays emanating from the extreme points B and C of the zone of light, and striking the disk at an angle α . To correct the value of the above proportion accordingly, we have to multiply the same by a factor $K < 1$, and then the light $\frac{J}{R^2} + K$ will correspond with the light H , which has been expressed by equation (1). Consequently, we have—

$$\frac{J}{R^2} \times K = \frac{J}{3} \left[\frac{2R}{(R^2 + e^2) \sqrt{R^2 + e^2}} + \frac{1}{R^2} \right]$$

and then

$$K = \frac{1}{3} \left[\frac{2R^3}{(R^2 + e^2) \sqrt{R^2 + e^2}} + 1 \right]$$

(To be concluded.)

ITEMS OF INTEREST FROM VARIOUS LOCALITIES.

FAILURE OF A GAS COMPANY.—The proprietors of the Middletown (Ohio) Gas Light and Coke Company made an assignment, on May 5, to Mr. C. W. Margerum. The assets are returned at \$5,000, with no statement as to liabilities. A good worker ought to earn a fair profit in supplying gas at that point.

PUBLIC LIGHTING AT GALVESTON, TEXAS.—In accordance with the report of lighting committee of Galveston City Council, the contract for public lighting at that place has been awarded to the Gas Company. The contract covers two years from 3d inst. The local branch of the Brush Electric Light Company submitted bids for either arc or incandescent lighting. The concluding portion of the committee's report is appended: "Your committee agree with the generally expressed opinion since this subject has been before the public that the lighting of the center of the city, where so much life and property would be endangered in case of the failure of electricity to furnish light, would be hazardous. The next two years will doubtless demonstrate the practicability of electricity and its safety and economy as compared with gas. The conclusion has been reached that it is advisable, and we so recommend, that the bid of Galveston Gas Company, for gas to light the street lamps, at \$2 per lamp per month, and the various city buildings at \$2.25 per thousand cubic feet of gas supplied, be accepted." The report and recommendation were adopted. The vote in Council was 9 in favor, 2 against. Naturally enough, Brother Beck and his board of directors are firm believers in the saying that "all things come to those who wait," especially when one is able to "wait in front."

AT THE RISK OF REPETITION.—Although even at the risk of repeating that which was said before in these columns, we mention the fact that the premises known as the Victor Emanuel Gallery (Milan, Italy) is roofed with glass and finished off with a huge dome, round the interior of which a chain of gas lamps is arranged. Owing to the great elevation the ignition of these lamps was a troublesome task, but now electricity performs the work. A miniature railway passes by the gas burners, the rails being employed to afford a roadway for a small electric locomotive that carries a conveniently placed wick saturated with spirits of wine. When the hour for lighting the gas burners has arrived the wick is ignited and the locomotive started on its journey. Flying over its roadbed the gas jets are speedily lighted, and the novel operation arouses much interest among the thousands who nightly assemble to witness the operation.

INCREASING ITS SCOPE.—According to plans recently filed with the San Francisco (Cal.) Board of Supervisors, we note that the Central Gas Light Company, of that city, will increase its main system by 5,225 feet of various sizes of pipe. The location of the new conduits is thus apportioned: Hayes street, from Fillmore to Laguna; Fillmore street, from San Francisco to Filbert; Union street, from Fillmore to Octavia.

STILL SPREADING.—The St. Paul (Minn.) Gas Light Company intends to make many important extensions to its manufacturing plant, and some account of these will in due time appear in our columns. In the meantime, in order to clear the way for the reception of the new plant, the managers offer for sale quite a variety of apparatus that may just meet the needs of gas proprietors in other places. The advertisement cataloguing the articles to be disposed of can be found in our regular advertising columns, and the voucher from Secretary Frost, that the offered wares are in good condition, is bond enough for intending purchasers.

TO WHOM THE CONTRACTS WERE AWARDED.—Some time ago we noted that Supt. Austin C. Wood, of the Syracuse (N. Y.) Gas Light Company, was about to make arrangements for enlarging the present model plant. We are now in position to say that the preliminary negotiations have resulted in the following awards to Mr. T. F. Rowland, of the Continental (Greenpoint, N. Y.) Iron Works: New purifiers, 20 ft. square, with 20-inch connections; also, a telescopic holder, 100 ft. by 101 ft. 6 in., in two sections of 20 ft. each, the holder to be inclosed in a brick building. The purifiers are to be placed in line, and the purifier house is to have the dimension of 115 ft. by 32 ft., with an annex (30 ft. by 60 ft.) for lime, etc., storage. The lime will be taken from storage room in cars running on tracks on either side of the boxes, the foul lime being carried out in a car, suspended from an overhead track directly above the center of the boxes. A chimney for ventilation, and a complete deodorizing apparatus will be included in the arrangement of the purifying plant. All the work is to be completed in ample season for the ensuing winter season. Brother Wood does not say much as a rule; but, nevertheless, there are few if any gas works in the country better adapted to the purpose in view than those located in the business heart of Onondaga county. Handsome is that handsome does!

TO APPEAL.—Timothy Schwarz and others—whose suit against the Consolidated Gas Company, of Baltimore, Md., to restrain the latter from charging a higher rate for gas in non-competitive districts than in sections where competition did exist, was decided in favor of plaintiff—have given notice that an appeal will be made to a higher court. It is safe to predict that the original decision will be sustained.

NAMING CHICAGO'S GAS METER INSPECTOR.—Mayor Roche, who succeeded the "only" Carter H. Harrison as Mayor of Chicago, has selected Col. Quirk to fill the position of Inspector of gas meters in the Windy City.

NEW GAS COMPANY.—A Company has been formed for the purpose of building a gas works in St. John's, Michigan. It is capitalized in \$25,000, and the proprietors assert that construction work will at once be proceeded with. St. John's is the capital of Clinton county, Mich., is 98 miles northwest of Detroit, and 22 miles north of Lansing. Population about 5,000.

ANNUAL ELECTION, PEOPLE'S COMPANY, CHICAGO, ILLS.—The stockholders of the People's Gas Light and Coke Company, at a meeting held May 3, re-elected the following officers: President, A. M. Billings; Vice-President, C. R. J. Billings; Secretary, J. S. Zimmerman. The officials admit that their Company is virtually a member of the newly-organized Chicago Gas Trust, but they also assert that such membership would make no material difference either in the conduct of the People's Company's business, or on the price it was to charge for gas.

ANNUAL ELECTION, WILMINGTON, N. C.—At the Annual meeting of the stockholders of the Wilmington Gas Light Company, held May 3, Messrs. D. MacRae, G. R. French, A. J. De Rosset, G. W. Kidder, J. F. Divine, G. S. Smith and E. S. Martin were chosen as Directors. At the organization meeting of the Board the following officers were chosen—all re-elections: President, E. S. Martin; Sec. and Treas., R. J. Jones; Supt., Jno. W. Reilly.

KILLED BY ELECTRICITY.—Jno. H. Simpson came to this city, from Philadelphia, Pa., some weeks ago under engagement to act as night engineer in the Adams Express Company's buildings, at 41 Trinity place. The Company employs an isolated plant for the lighting of its premises, and Simpson (who was supposed to understand all about dynamos, etc.) was required, in the performance of his routine duty, to keep an eye on the lighting apparatus. On May 5 he invited a friend (J. S. Helme) to inspect the dynamos, etc., and while the examination was being made Simpson said to his companion, "Electricity does not affect me much any more; what would knock you out in a second I can hold without turning a muscle." He then attempted to induce Helme to make some experiment with the wires. Meeting a refusal, Simpson grasped one wire with both hands without apparent ill effect; then grasping both wires, one in either hand, the lights were instantly extinguished, and the unfortunate trifler dropped to the floor lifeless. Medical aid was at hand forthwith, but was powerless.

ANOTHER DEATH.—Thos. Tighe, aged 25, an employee of the Philadelphia Brush Electric Light Company, was killed by an electric current while at work on one of the Company's wires where the same cross Sixteenth and Barker streets. Deceased was about 30 feet from the ground when the current entered him, but owing to the peculiar position assumed by his body as a result of the shock the wires held him firmly in mid-air. When reached by the relief party Tighe was a corpse. The wire carried the current from a 60-light dynamo, and was in duty all day. Supt. Law could not account for the accident. In connection with apparent death from an electric shock the London *Journal* recently said that "The phenomenon of death produced by strong electrical currents has never ceased to puzzle physiologists and electricians. Men have been killed by contact with exposed wires conveying electromotive force at a high potential; but how or why this effect has been produced in the living organism has often been left a mystery. By a series of experiments with different sources of electricity M. d'Arsonval has arrived at the same conclusions as Dr. Brown-Sequard, which are that death is sometimes caused by the mechanical action of electrical discharges in the alteration of organic tissue, in which case, of course, there is no cure; and sometimes the effect is produced indirectly by disturbance of the nervous system. Mere difference of potential or mean intensity of current does not constitute the sole element of a dangerous discharge; but this is a matter that requires further investigation. The practical result of M. d'Arsonval's experiment is to show that where persons are apparently killed by such electrical currents as are used for industrial purposes they should immediately be treated in the same way as persons apparently drowned—by the application of artificial respiration. In the majority of cases these deaths have been due to the arrest of the function of respiration. Artificial respiration, therefore, by preventing asphyxia, is indicated as the rational restorative agent."

REPLACED BY GAS.—Messrs. Specht & Co., of St. Louis, Mo., are proprietors of a mammoth mercantile establishment in that city—it is known to the entire West as the "Famous Clothing House"—and they have employed the arc light for purposes of illumination for quite a while. A month or so ago, however, one of the members of the firm happened in to the office of the Laclede Gas Light Company, and there saw one or two specimens of the Siemens-Lungren burner in duty. Noticing the excellent quality of the light evolved, he inquired about their general efficiency, cost, economy, and so on, and finally ordered that two or three of them be sent over and put up in the warerooms of the "Famous" for practical trial. Result—the entire establishment is to be illuminated by Siemens-Lungrens.

MR. HOPPER'S NEW ADDRESS.—Mr. T. C. Hopper, ex-President of the American Meter Company, expects hereafter (in order to insure proper receipt) that all who wish to communicate with him will address their messages to "38 West Walnut Lane, Germantown, Penna."

LOOK OUT FOR THE FRAUD.—The fraternity of the country are hereby warned that a fraud who travels under the *nom de ruse* of Sigismund Guttman may appeal to their sympathies for pecuniary assistance—that is, he may appeal to others who have not had the honor (and ill-luck) of a call from him already. He is a rank humbug; but a word to the wise, etc.

TO BUILD THE SPRINGFIELD (MASS.) GASHOLDER.—The contract for the construction of the 300,000 cubic feet capacity holder, to the order of the Springfield Gas Light Company, has been awarded to Mr. T. F. Rowland.

THE CLEVELAND (OHIO) NATURAL GAS ORDINANCE.—We have to thank Mr. G. A. Hyde, of the Cleveland Gas Company, for a copy of the ordinance recently passed by the Cleveland City Council for the admission and regulation of companies which propose to supply natural gas for fuel in that city. Having prescribed the legal form necessary for admission, incorporation, and stipulating that admission carries with it the right to supply "natural gas for fuel, heating and power purposes only," setting forth the manner in which the transportation conduits shall be laid, as well as other matters germane to the subject, inclusive of the filing of proper indemnity bonds, etc., the document (Sec. 2) further specifies, "The said companies shall furnish and supply natural gas to all consumers at a uniform rate or price for domestic purposes, and a uniform rate or price for manufacturing purposes, which latter rate may be a lower rate, except that said companies shall furnish natural gas to the said city at a cost of ten per centum less than its schedule rates to private consumers for domestic purposes when used for heating, and ten per centum less than the schedule rate for manufacturing purposes when used for power purposes only, for the buildings of the police, fire department, water works, etc. In its location of its system of pipes no company shall discriminate against the city." The companies must file with the City Clerk, prior to beginning the supply of gas, a schedule of the prices proposed to be charged (which initial schedule is in no case to call for in any period a charge in excess of 75 cents per thousand), but the first sched-

ule may be subsequently amended by consent of the Common Council. The scheme of ordinance has been carefully studied out, and clearly laid down.

NEW RATES FOR GAS AT APPLETON, WIS.—Mr. Wm. B. Miller, Secy. of the Appleton Gas Light Company, sends us the following official announcement: From first inst. "all consumers using less than 500 cubic feet of gas per month will be charged for the same at the rate of 30 cents per 100. In all cases where the meter does not register 100 cubic feet monthly a meter rental of 25 cents per month will be collected." *Special Rates for Fuel Use.*—"From May 1 to Nov. 1 of each year gas will be furnished for gas stove purposes at \$1.75 per 1,000 cubic feet. During the same months, to consumers using gas for fuel and lighting purposes, gas will be supplied for \$1.60 per thousand. The consumption of gas to secure this special rate must be 1,000 cubic feet or upward, monthly, and all bills must be settled on or before the tenth of each month."

THE MONTCLAIR (N. J.) GASHOLDER.—We noted in our last that the Montclair Gas Company would make extensive plant improvements this season. Among other items it was specified that the storage capacity was to be greatly increased, and since time of prior writing we may explain that the holder (to have a capacity of 100,000 cubic feet) contract has been awarded to Messrs. Deily & Fowler, of Philadelphia, and A. H. Clark, of Newark, N. J., is to perform the necessary excavation and mason work. The entire work will be under the immediate supervision of Mr. Wm. Mooney, who, by-the-way, has succeeded to the business of Mr. Wm. Farmer, retired. Mr. Mooney has opened an office at No. 27 Pearl street (convenient to Whitehall street), and those of the fraternity who require the aid of a finished draughtsman, a careful estimator, or competent constructor, will do well to consult him. The Montclair improvements are to be completed by September.

ANOTHER NEW HOLDER.—The Hudson County (N. J.) Gas Light Company has determined to construct a single-lift holder, 50 feet diameter, 17 feet section. The Company's plant is located in Hoboken, N. J.

TO GO AHEAD.—Last year the Common Council of Utica, N. Y., granted a franchise for the erection and operation of an opposition gas works in that city, to the proprietors of the Equitable Gas Light Company, of the United States. Having secured the right, no positive action was taken under the grant until a fortnight ago, when, at a meeting of the projectors, held in New York, the Utica Equitable branch was reorganized, and Mr. E. N. Dickerson was elected as its President. The capital stock was fixed at \$400,000, and that amount is asserted to have been at once subscribed for. Construction work will be inaugurated speedily.

ANNUAL MEETING, PITTSFIELD, MASS.—At a recent meeting of stockholders in the Pittsfield Coal Gas Light Company the following officers were appointed: President, R. W. Adam; Clerk and Treas., W. R. Plunkett; Directors: W. R. Adam, W. G. Backus, Jas. W. Hull, D. J. Dodge, and W. R. Plunkett.

PASSED AND VETOED.—The Omaha (Neb.) City Council recently granted a franchise for an opposition gas works in that city. The newcomers style themselves the Nebraska and Kansas Gas and Heating Company, and they propose to employ the Reinhold Boeklen process for making water gas, using crude petroleum as an enricher. The Company is capitalized in \$1,000,000, and L. W. Hill, M. Meyer and C. E. Lee are named as sponsors. Mayor Boyd, however, vetoed the ordinance, and we must say that his reasons for so doing are sound and logical. It might be further said that the opposition proposed to supply gas at \$1.25 to private consumers, and at \$1 to the city. The old Company, we believe, under a former ruling of the Council, is to supply gas at the rate of \$1.75 per thousand.

SOME CONTRACTS RECENTLY SECURED BY MR. WEBER.—Among other orders recently received by Mr. Adam Weber, we note the following: All the fireclay materials required to complete twelve benches of sixes at the 14th street station of the Consolidated Gas Company of this city. Eight of these benches will be fired with his new and improved half-depth regenerative furnaces from designs especially made for the station in question. Also to supply the superheater and generator materials for the branch works of the United Gas Improvement Company, at Jersey City and Paterson, N. J.; and to equip the works of the San Diego (Cal.) Gas Light Company with two benches of sixes, to be fired on the half-depth regenerative plan.

PROGRESS MADE BY THE NATIONAL GAS FUEL AND LIGHT COMPANY.—The proprietors of this Company report that their system is growing in favor, and that the outlook for the future is of the most encouraging character. Since Jan. 1st they have contracted to put in the Springer generating apparatus in the gas plants located at Los Angeles and San Diego, Cal.; Lima and Bucyrus, Chio; Grand Forks, Dak. Ter.; Bellevue, Ky.; Hastings, Neb.;

St. John's, Mich.; and Morris, Ills. This list leads us to remark that the National Company seems to possess a pretty widely extended territory as a stamping ground.

TO SUPPLY THE METERS.—Messrs. Helme & McIlhenny, of 1115 and 1117 Cherry street, Phila., Pa., have been awarded the contract to furnish meters to the Philadelphia gas works during the ensuing year.

THE BILL to oblige the gas companies of Brooklyn to supply gas at a rate not to exceed \$1.60 per thousand cubic feet has been signed by Gov. Hill. Other reference to this matter will be found in our editorial columns.

GAS COAL BIDS.—Director Wagner, the Gas Committee of Councils being in attendance, opened the bids for supplying bituminous and cannel coals to the Philadelphia (Pa.) gas works for the ensuing year, on date selected. The bituminous tenders showed a maximum of \$4.10, and a minimum of \$3.60. The following cannel propositions were submitted: Messrs. J. D. Perkins & Co., N. Y., offered Breckenridge at \$10.45, and Plesio-Boghead at \$7.65; Caunelton was offered at \$8.75; Jas. and Wm. Wood, of Glasgow and London (Europe) proposed to supply Earl of Hopetoun cannel at \$9.20.

CHEAPER GAS FOR DETROIT MICH.—We are indebted to the courtesy of Mr. Chas. A. King, Secretary of the Detroit Gas Light Company, for the information that a uniform net rate of \$1.50 per thousand cubic feet for gas sold in that city took effect on May 1. This is equivalent to a reduction of 25 cents per thousand, and means cheap light for the Wolverines. Happy in the possession of good and cheap light, and the coming champions of the base ball arena already in their midst—what other glory can Detroit seek for?

THE WAR IS ENDED.—A month ago we explained that the rather small, though energetic, city of Maysville, Ky., boasted of a red-hot gas war because two rival gas companies were in the field. Now, however, the cruel war is over, and the armistice is signed, the Citizens Company having, on May 7, surrendered to the terms proposed by the Maysville or old Company. The old Company bought out their antagonists. During the competition the price of gas was reduced from \$3 to 75 cents per thousand cubic feet.

A NARROW ESCAPE.—At 3 A.M., Sunday, May 8, the electric lights in the Kirkwood House, Detroit, Mich., were suddenly extinguished. The night clerk instantly aroused proprietor Clark, and an exploring expedition (candles doing duty as torches) was at once instituted. The "smell of fire" was traced to the cellar of the building, and a visit to that region developed the startling fact that an iron conduit, conveying a number of electric light wires into the building, was actually "running down the wall like water." That is, it was rapidly melting. Word was at once sent to the electric light station, when the current was shut off and the slight headway gained by the flames on the woodwork was checked. The electricians said that a "cross" was at the bottom of the difficulty; but if it were not for the alertness of the night clerk many of the guests might have had a speedy chance to determine whether their crosses were to end in crowns or not. It goes without saying that the Kirkwood corridors were quickly peopled with an anxious and ghostlike throng, and that many of the "ghosts" concluded it was too near daylight to seek to woo Morpheus anew. All's well that ends well; still we cannot help thinking that Detroit was uncomfortably close to a hotel horror on the morning mentioned.

DELAWARE (OHIO) MAKES THE CHANGE.—It will be remembered that Judge Jones, of Delaware, spoke rather strongly, during the recent meeting of the Ohio Association, against the policy, *per se*, of discriminative rates in general; and those who carefully read his argument have undoubtedly concluded that the Judge talked soundly and concluded logically. Nevertheless, his Honor after all seemed to have discovered a way through which the proverbial coach and four might be driven beyond the "bulwarks of the law;" for he hinted that the Delaware Gas Company might, during the coming season, see its way clear to establishing an attractive rate for gas consumed in domestic and power operations. At any rate, the Delaware Company has promulgated a \$1.50 charge for gas so used, and proposes to win the day, if a victory can be achieved in that section on that basis. Gas stoves will either be rented or sold, as the user elects; and the selection can be made with economy, no matter which end of the proposition is accepted. For instance, if outright purchase be decided upon, the buyer pays only the stove manufacturer's charges; if rental be agreed to, a yearly tariff of \$2 or \$3, according to size of apparatus, is stipulated. Further, the Delaware folks make no charge for "setting them up." Judge Jones and Brother Converse have devised a thoroughly attractive plan, and the effect will be developed in the next return of total annual output. Take it all-in-all, the corollary—it had the weight of a trip-hammer, too—of Mr. Padan, of Portsmouth (made at the Ohio meeting), is correct in the long run. Mr. Padan,

in speaking of discriminatory rates, said: "What is the use of objecting to the plan? We will do it; and that is the end of it."

GOOD FOR WOONSOCKET, R. I.—Brother Jenks and his associates in the management of the Woonsocket Gas Company must have been in "executive session" again, for we have received official assurance that all gas consumed in that vicinity, since 1st instant, and "until further notice," is to be supplied at the rate of \$1.60 per thousand—the prior rate was \$1.80—and thus does the "crank get another turn"—in the right direction.

FIRE.—About the 1st instant the generator building of the Citizens branch of the Louisville (Ky.) Gas Light Company was damaged by fire to the extent of \$2,000.

NEW WORKS AT WINSTON, N. C.—The Winston Electric Light and Motive Power Company has been chartered. The proprietors favor the combined plan, and are now putting in a Brush plant; if the people respond favorably a gas works will also be built. Winston is the capital seat of Forsyth county; is contiguous to Salem, and is about 35 miles northeast of Salisbury. Population, about 4,500.

NEW HOLDER.—The Laclede Gas Light Company (St. Louis, Mo.), will build a holder on Easton avenue, between Sarah and Warren streets. Capacity, 1,000,000 cu. ft.; cost, about \$70,000.

UNCLE SAM'S LIGHTING BILL.—It is asserted that the artificial illumination of the various public buildings devoted to the uses of the government costs Uncle Sam something like \$750,000 per annum.

GAS WORKS FOR GRAVESEND, N. Y.—On May 2 Messrs. H. J. Hubbard and W. C. Jones, of this city, with F. H. Smith, of Brooklyn, filed a certificate in Albany which incorporates the Gravesend Gas Light Company. The Company is capitalized in \$100,000. Gravesend is some six miles south of Brooklyn. The summer resort known as Coney Island is within the boundaries of the township.

ELECTION OF DIRECTORS.—At the annual meeting of the stockholders in the Equitable (Balt., Md.) Gas Light Company, Messrs. G. J. Forrest, H. Fitzhugh, W. H. Rome, Robt. Garrett, and A. Roos were chosen Directors.

AGITATING THE SUBJECT.—Many of the prominent residents of Sumter, S. C., are considering the feasibility of organizing a gas company for that place. Sumter is the capital seat of a similarly named county in South Carolina, in the east-central portion of the State.

Correspondence

[The JOURNAL is not responsible for the opinions expressed by correspondents.]

A Letter from the President of the Port Hope (Ont.) Gas Company.

GAS COMPANY, PORT HOPE, ONT., May 5, 1887.

To the Editor AMERICAN GAS LIGHT JOURNAL:

In the proceedings of the meetings of the various associations of gas managers, which reports I read with great interest and profit, I have never seen any statement made about the effect of the introduction of electric light in towns like ours (containing about 5,000 inhabitants) in opposition to an existing gas company.

I inclose our yearly report which may throw some light on this point, for we have been through the fire; and the conclusion I have arrived at in regard thereto is that *two* light companies cannot be operated at a profit in small towns.

Our corporation light our streets now with 23 arc lamps, displacing 60 gas lamps, at a cost of 25 cents each per night, to 12 m. The electric company have 7 other lights, in hotels and saloons, for which they charge 30 cents per night; and they also pay \$400 per year rental for water power.

I should very much like to hear on this point from some of the managers of similarly situated companies; and also as to what percentage of loss should fairly take place, in the distribution of gas, after the latter has passed the station meter.

Yours, JOHN SMART, Prest.

[We append President Smart's annual report to the stockholders of the Port Hope Company, for the year ended March 31, 1887.]

Last year, in our yearly report, we informed you, in speaking of the future prospect of the Company, that that largely depended on the action of the Town Council in respect to the street lighting contract, which has since, for three years, been awarded to the electric light company. We regret this, as in doing so a serious blow was dealt this Company, who had faithfully performed their contract with the corporation, and in which the ratepayers are the largest shareholders, and out of whose profits they derived a divi-

dend almost sufficient to pay the outlay for street lighting, which now, under existing circumstances, must be taxed for to a large extent.

Last year we paid a dividend of seven per cent. out of our net earnings of \$2,536.99, but this year we have, with the greatest economy possible with a good service, only \$1,508.88 at credit of that account, out of which we have declared a dividend of 3½ per cent., and carry the balance, \$288.75, to profit and loss account, which sum far from covers the loss sustained this year by the action of the Council rendering valueless over 3,000 feet of our pipeage, put down at the request of the corporation to supply street lamps, on which there is not now nor never has been a private consumer. These pipes are at present of no value to the Company, as they are not worth the cost of removing, and are now cut off.

Then, again, the whole pipeage of the Company will only last a certain number of years, and no provision has as yet been made for the cost of renewal, or for the deterioration of the general plant of the Company. To provide a sufficient rest to meet such outlay, deterioration and risks as are incidental to all such companies, would not only be prudent but proper, in order to protect the shareholders against sudden calls for such a purpose.

During the past year a fair number of new customers have been added to our consumers; but the increased consumption has fallen far short of making good the loss in profits caused by the reduction in price of gas, when promptly paid, to \$2.50 per 1,000.

We have also added several new customers for gas fuel, and those who used it last summer are so well satisfied as to its convenience, cleanliness, economy, and the almost entire absence of heat in the kitchen, that they are now recommending its use to their friends. We therefore look for a considerable increase in the use of gas as a summer fuel, but at the present price of \$2 per thousand there is only a very small profit; indeed, the principal gain to the Company is in the employment of our men and works during the summer when sales for light are small.

Our meters have again been all inspected by the Government Inspector, and pronounced by him in perfect order. The outlay for repairs and inspection of meters has this year been double our receipts for rents; but now, for a year or two, our expenses, except for new meters, will be small, and probably recoup our present shortage on that account.

The Government Inspector's certificate for the past year shows that the gas furnished by the Company to its patrons has considerably exceeded the standard of 16-candle power required by law. Thus guarded by meter inspection, and test of power of light and its purity, the public have the fullest guarantee that the gas furnished is of the quantity, quality and purity claimed for it.

The adoption of the rule that the Company should consider the meter the point of delivery, and care for the service pipes to that point, has resulted in the renewal of many of these which were found defective, and thus removed a constant source of irritation between the Company and its customers.

The use of gas in private houses is still limited; indeed Port Hope, for its population and wealth, is in this respect behind other towns. It is hard to account for this, unless it be that the careful housewife ignores the fact that a Rochester coal oil lamp will consume in 32 hours a gallon of coal oil at a cost of 30 cents, whilst a three-foot gas burner will consume in 33 hours 100 feet of gas and cost only 25 cents, giving a stronger light, and that without breakage of chimneys or lamp cleaning.

All taxpayers are directly interested, through the town stock, in the welfare of this Company. Anything, therefore, that can be done to add to its prosperity and increase its dividends, simply reduces their taxes; any adverse action, on the contrary, adds to their burdens and destroys the value of their own property. To illustrate this: The probable market value of the stock of a Company such as this, liable to explosions and new inventions, if paying 7 per cent., dividends would probably be 70 to 80 cents on the dollar; whilst if 3½ can only be paid, then, in same ratio, 35 to 40 cents would be its value.

Receipts.

Gas sold.....	\$5,156.23
Meter Rents.....	288.00
Coke, tar, etc.....	461.09
	<hr/>
	\$5,905.32

Expenditures.

Coal used.....	\$1,610.90
Salaries, wages and office expenses.....	1,564.63
Repairs and renewals.....	413.86
Meter inspection and repairs.....	516.87
New meters.....	48.35
Directors' fees.....	70.00
Taxes.....	171.83
Dividend, 3½ per cent.....	1,220.13
Profit and loss.....	288.75
	<hr/>
	\$5,905.32



A. M. CALLENDER & CO.,

PROPRIETORS.

Editor—JOS. R. THOMAS, C.E.
Asst. Editor—T. J. CUNNINGHAM.
Manager—C. E. SANDERSON.

PUBLISHED ON THE 2ND AND 16TH OF EACH MONTH
At No. 42 Pine Street, New York.

This is a recognized official organ of—
LIGHT, HEAT, STEAM, WATER-SUPPLY,
VENTILATION, SANITARY IMPROVEMENT,
AND GENERAL SCIENCE.

TERMS

SUBSCRIPTION—Three Dollars per annum, in advance.

AGENTS

NEW YORK—AMERICAN NEWS Co., 39 and 41 Chambers St.
BOSTON—S. M. PETTINGILL & Co., 6 State Street.
PHILADELPHIA—PRATT & Co., Corner 9th and Arch Streets.
England—C. W. HASTINGS, 22 Buckingham St., London, W C
Germany—B. WESTERMANN & Co., of New York

MONDAY, MAY 16, 1887.

State of the German Coal Trade.

Engineering complains over an inability to describe the coal industry as being in a very flourishing state at present, the continued spell of mild weather having served to reduce the demand for home coal to a minimum. Steam coal, however, being in increased request in consequence of the activity of the iron industry, somewhat compensates for this. Concern is being manifested in interested circles over the fact that, in spite of Germany's known practically inexhaustible coal beds, the export trade is gradually diminishing, while the import of English and Welsh coal is developing wonderfully. To the heavy railway rates in force between the coal fields and the northern ports is attributed this state of affairs. All the mining companies embraced in the body known as the Bochum Mining Syndicate have pledged themselves to restrict the output for the remainder of the year 2½ per cent. as compared with the production of 1886.

Bidding Good-By to Mr. Pratt.

A fortnight ago we had occasion to inform our readers that Mr. E. G. Pratt, Supt. of the North Attleboro (Mass.) Gas Company, had resigned his position with that corporation in order to assume charge at the Des Moines, Iowa, works. Wishing to say farewell to those who had labored under him so faithfully during his residence in "Jewelry Town," Mr. Pratt invited them to a social tea, at his home on Elm street, on the evening of the 9th inst. A bountiful supper was supplied, to which the men did ample justice. The post prandial exercises, however, were a surprise to Mr. and Mrs. Pratt. The foreman, in a brief speech, alluded to the pleasant relations that had always existed between the Superintendent and his men, and in their behalf presented Mrs. Pratt with an elegant alligator traveling bag, and Mr. Pratt with a silver mounted, snake-wood cane. The Superintendent,

ent, although taken by surprise, responded feelingly to this unexpected token of the esteem of his workmen. The evening was passed in social festivities. Mr. Pratt leaves for Des Moines to-day.

Paying the Electric Piper in Brooklyn, N. Y.

The Brooklyn *Eagle* in summing up the changes in the public lighting supply of that city says that the political electricians, during the investigation by the Bacon Committee, endeavored to create the impression that the introduction of the electric light in Brooklyn had tended to reduce the prices asked by the different gas companies for street lighting. The city commenced to use electricity for street lighting purposes in 1885. It appears from the records of the Brooklyn Gas Company, which lights some of the most populous sections of the city, that the price for gas lights furnished to the city was reduced in 1879 from \$22 to \$20 per lamp. This price continued until 1883, when it was further reduced to \$19.80, and has since remained at that figure. It will be seen that these reductions were all named more than two years before the introduction of the electric lights. There have been discontinued since June, 1885, by the various gas companies in this city, 4,844 gas lights, which cost per year \$103,578.85. To supply the place of these gas lights there have been erected 995 electric lights, for which the city pays \$182,582.87 a year. The city is therefore paying \$77,903.15 more for street lighting by electricity than it had previously paid for gas. The city records show that for each electric light set up there have been discontinued 4^{8/10} gas lights. The various companies of the city agree to furnish three cubic feet of gas per hour to each light, which would give, say, a light equal to 12 candles. If the electric lights are of the illuminating power of 1,200 candles each, then each electric light should displace 100 gas lights instead of only displacing 4^{8/10} gas lights.

The Cost of Public Electric Lighting in Worcester, Mass.

A Worcester exchange, commenting on a proposition recently made by the local electric light company to the city authorities, explains that the cost of electric lighting in the following-named cities is returned at—

	Price	Candle Power.	Time.
Boston.....	65	2,000	All night
East Boston.....	65	2,000	"
Holyoke.....	65	2,000	"
Holyoke..	50	2,000	Till 12
Lowell.....	60	2,000	All night
Lynn.....	47½	2,000	Till 1
Taunton.....	60	2,000	Till 12
New Haven.....	55	1,200 and 2,000	All night
Brooklyn.....	50	1,200	"
Baltimore.....	70	2,000	"
Philadelphia.....	55	2,000	"
Springfield.....	70	2,000	"
Worcester.....	60	2,000	"

—and then goes on to say that in Natick, where the price is 30 cents, the lights are 1,200 candle power and burn until 1 o'clock. The cost, if the 1,200 candle power lights were run all night on the same basis, would be 50 cents. In Providence and Salem, which are often quoted, the price is due to very sharp competition, and coal is much cheaper in the former city. It is easy to figure out that, with the cost for each light in Worcester reduced 5 cents, the saving on each light in 365 days is \$18.25, and that with 113 lights the cost is \$2,062.25 less than for the same number at present. The offer for a three years' contract at 55 cents makes the yearly cost \$2,062.25 less than at present, which will pay for 10 additional lights. The proposition of the company was for a five years' contract, and the proposition recommended by a majority of the street lighting committee is for a three years' contract.

The Market for Gas Securities.

The city gas share market still "hangs fire" in a rather unaccountable fashion, but holders evidently are indisposed to accept the offers of would-be buyers. Consolidated (May 14) opened at 86½, and has ruled strong during the fortnight. The approach of dividend day, of course, has much to do with the situation; and we incline to the idea that those who are desirous of making a quick turn prior to that time (a quick turn meaning in this case a profit of one or two points) can safely make the flyer at anything below 86. Other city shares are listless. The \$1.60 gas rate in Brooklyn, now that that is a fixed fact, does not seem to have exerted any appreciable effect on values. A very fair inquiry is being made for the shares, and we think they are cheap at ruling prices. We understand that the Laclede (St. Louis, Mo.) Company has decided to enter the Gas Trust of that city on its own terms. The Chicago (Ills.) love feast has been consummated, and it may be taken for granted that the deal in Baltimore is pretty near completion. We note that original Equitable stock, of Chicago, is bid for at 112. At auction, we note a sale of 700 shares of Jersey City gas, at \$168; 10 shares Citizens (Brooklyn), at 56; and \$500 Nassau (Brooklyn) certificate, at 100. Any gas share on the list seems to be a purchase.

REORGANIZED.—The Middletown (N. Y.) Gas Company will hereafter be called the Middletown Light and Fuel Company. The new owners signaled their accession to management by reducing gas rates to \$2.35—former rate, \$2.50.

TYLER, Texas, may have a gas works. Colonel S. W. Fordyce and associates are negotiating for the franchise.

STEALING STREET LAMPS.—Mr. J. J. Robinson, who has charge of the lighting of the oil street lamps in Portland, Oregon, says that in the "Slabtown" district during the past three months more than 30 lamps have been stolen. The lamps are taken, as near as can be learned, just after the men have been around filling them with oil. Mr. Robinson is authority for the statement that the larceny of these lamps is the cause of so many complaints of "no light" from that section of the city.

LIGHT FOR CENTRAL FALLS.—The Pawtucket (R. I.) Gas Company has contracted with the Fire District Committee for Central Falls to furnish gas, to light and extinguish the burners, and to keep the lanterns clean for one year for the sum of \$18.75 per lamp. The district will maintain about 125 gas and oil lamps.

Gas Stocks.

Quotations by Geo. W. Close, Broker and Dealer in Gas Stocks.

16 WALL ST., NEW YORK CITY.

MAY 16.

All communications will receive particular attention.
The following quotations are based on the par value of \$100 per share.

	Capital.	Par.	Bid	Asked
Consolidated.....	\$35,430,000	100	86½	—
Central.....	440,000	50	30	—
" Scrip.....	220,000	—	47	57
Equitable.....	2,000,000	100	125	130
" Bonds.....	1,000,000	—	113	115
Harlem, Bonds.....	170,000	—	—	—
Metropolitan, Bonds....	658,000	—	110	113
Mutual.....	3,500,000	100	100	102
" Bonds.....	1,500,000	1000	101	—

Municipal, Bonds.....	750,000	—	—
Northern.....	125,000	50	30
“ Scrip.....	108,000		
Youkers.....		50	80
Richmond Co., S. I.....	300,000	50	50
“ Bonds.....	12,000	—	—
Gas Co's of Brooklyn.			
Brooklyn.....	2,000,000	25	103
Citizens.....	1,200,000	20	54
“ S. F. Bonds....	320,000	1000	—
Fulton Municipal.....	3,000,000	100	139
“ Bonds....	300,000	—	106
Peoples.....	1,000,000	10	55
“ Bonds (5's).....	368,000	—	97
“ “ (6's).....	94,000	—	100
Metropolitan.....	1,000,000	100	83
Nassau.....	1,000,000	25	103
“ Cfts.....	700,000	1000	100
Williamsburgh.....	1,000,000	50	130
“ Bonds... ..	1,000,000	—	111
Out of Town Gas Companies.			
Boston (Mass.) Gas Co.	2,500,000	500	910
Buffalo Mutual, N. Y... ..	750,000	100	90
“ Bonds... ..	200,000	1000	95
Citizens, Newark.....	1,000,000	50	140
“ “ Bonds.	45,000	—	—
Chicago Gas Co., Ills... ..	5,000,000	25	142
Peoples G. L. & C. Co.,			
Chicago, Ills.....	3,000,000		29
Cincinnati G. & C. Co..	6,000,000	100	184
Consolidated, Balt.....	6,000,000	100	71½
“ Bonds....	3,600,000		107
Chesapeake, Balt.....	1,500,000	100	99
“	1,000,000		100
Consumers Toronto....	1,000,000	50	194½
Central, S. F., Cal.....			86
Capital, Sacramento, Cal.			56
Hartford, Conn.....	750,000	25	140
Jersey City.....	750,000	20	168
Laclede, St. Louis, Mo.	1,600,000	100	125
Louisville, Ky.....	2,570,000	50	130
Little Falls, N. Y.....	50,000	100	95
“ Bonds	25,000	—	100
Montreal, Canada.....	2,000,000	100	209
New Haven, Conn.....		25	193
Oakland, Cal.....			36½
Peoples, Jersey City... ..		—	25
“ “ Bonds..		—	—
Paterson, N. J.....		25	90
Rochester, N. Y.....		50	75
St. Louis, Missouri.....	600,000	50	—
San Francisco Gas Co.			
San Francisco, Cal....	10,000,000	100	59¾
Memphis (Tenn.) Gas... ..	750,000	100	—
“ Bonds.	240,000	100	103
Washington, D. C.....	2,000,000	20	210
Wilmington, Del.....		50	200
Havana (Cuba) Gas Co.	3,000,000	100	18
“ Bonds....	550,000		102

Advertisers Index.

GAS ENGINEERS.		Page
Jos. R. Thomas, New York City		332
Wm. Henry White, New York City.....		332
Wm. Mooney, New York City.....		332
William Gardner, Pittsburgh, Pa.....		332
GAS WORKS APPARATUS AND CONSTRUCTION.		
James R. Floyd, New York City		335
T. F. Rowland, Greenpoint, L. I.....		335
Deily & Fowler, Phila., Pa.....		335
Kerr Murray Mfg. Co., Fort Wayne, Ind.....		334
Stacey Mfg. Co., Cincinnati, Ohio.....		335
Bartlett, Hayward & Co., Baltimore, Md.....		335
Morris, Tasker & Co., Limited, Phila., Pa.....		334
Davis & Farnum Mfg. Co., Waltham, Mass.....		292
R. D. Wood & Co., Phila., Pa.....		334
Southwark Foundry and Machine Co., Philadelphia, Pa.....		334
Bouton Foundry Co., Chicago, Ills.....		335
PROCESSES.		
National Gas Light and Fuel Co., Chicago Ills.....		325

GAS AND WATER PIPES.	
Gloucester Iron Works, Phila., Pa.....	332
Meiert Foundry and Machine Co., Reading, Pa.....	332
Cincinnati and Newport Iron and Pipe Co., Newport, Ky... ..	332
Ohio Pipe Co., Columbus, Ohio.....	332
Pancoast & Rogers, New York City.....	332
M. J. Drummond, New York City.....	332
Wells Rustless Iron Co., New York City.....	321
GAS ENGINES.	
Schleicher, Schumm & Co., Phila., Pa.....	310
Clerk Gas Engine Co., Phila., Pa.....	327
RETORTS AND FIRE BRICK.	
J. H. Gautler & Co., Jersey City, N. J.....	330
B. Kreisler & Sons, New York City.....	330
Adam Weber, New York City.....	330
Laclede Fire Brick Works, St. Louis, Mo.....	330
Brooklyn Retort and Fire Brick Works, Brooklyn, N. Y.....	330
Borgner & O'Brien, Phila., Pa.....	330
James Gardner, Jr., Pittsburgh, Pa.....	330
Henry Maurer & Son, New York City.....	330
Chicago Retort and Fire Brick Works, Chicago, Ills.....	330
Baltimore Retort and Fire Brick Co., Baltimore.....	330
Oakhill Gas Retort and Fire Brick Co., St. Louis, Mo.....	330
Evens & Howard, St. Louis, Mo.....	331
Cincinnati Gas Retort and Fire Brick Works, Cincinnati, O.....	331
Emil Lenz, New York City.....	331
SCRUBBERS AND CONDENSERS.	
G. Shepard Page, New York City.....	333
REGENERATIVE FURNACES.	
Bartlett, Hayward & Co., Baltimore, Md.....	324
Fred. Bredel, New York City.....	321
GAS GOVERNORS.	
T. C. Hopper, Phila., Pa.....	328
CEMENTS.	
C. L. Gessold, Manchester, N. H.....	330
GAS ENRICHERS.	
Standard Oil Co., Cleveland, Ohio.....	336
GAS METERS.	
Harris, Griffin & Co., Phila., Pa.....	338
American Meter Co., New York and Philadelphia.....	339
The Goodwin Gas Stove and Meter Co., Philadelphia, Pa... ..	339
Helme & McIlhenny, Phila., Pa.....	339
D. McDonald & Co., Albany, N. Y.....	339
Nathaniel Tufts, Boston, Mass.....	338
EXHAUSTERS.	
P. H. & F. M. Roots, Connersville, Ind.....	326
Smith & Sayre Manufacturing Co., New York City.....	326
Wilbraham Bros., Philadelphia, Pa.....	326
Connelly & Co., New York City.....	327
GAS COALS.	
Penn Gas Coal Co., Phila., Pa.....	337
Perkins & Co., New York City.....	336
Newburgh Orrei Coal Co., Baltimore Md.....	337
Despard Coal Co., Baltimore, Md.....	337
Chesapeake and Ohio R.R. Coal Agency, N. Y. City.....	337
Westmoreland Coal Company, Phila., Pa.....	337
Monongahela & Peters Creek Gas Coal Co., Pittsburgh, Pa..	337
CANNEL COALS.	
Perkins & Co., New York City.....	336
J. & W. Wood, New York City.....	336
VALVES.	
Ludlow Valve Manufacturing Co., Troy, N. Y.....	328
John McLean, New York City.....	328
Chapman Valve Manufacturing Co., Boston, Mass.....	328
ENGINES AND BOILERS.	
Jarvis Engineering Co., Boston, Mass.....	324
PURIFYING MATERIAL.	
S. H. Douglas, Ann Arbor, Mich.....	331
GAS LAMPS.	
The Siemens-Lungren Co., Philadelphia, Pa.....	333
G. Shepard Page, New York City.....	332
Albo-Carbon Light Co., Newark, N. J.....	325
Standard Gas Lamp Co., Phila., Pa.....	331
Geo. H. Gregory, New York City.....	331
PURIFIER SCREENS.	
John Cabot, New York City.....	331
Geo. A. Mills, Baltimore, Md.....	331
GAS STOVES.	
American Meter Co., New York and Philadelphia.....	329
The Goodwin Gas Stove and Meter Co., Phila. Pa.....	308
STREET LAMPS.	
J. G. Miner, Morrisania, New York City.....	324
Bartlett Street Lamp Mfg Co., New York City.....	328
BURNERS.	
G. Gefroerer, Phila., Pa.....	336
STEAM BLOWER FOR BURNING BREASE.	
H. E. Parson, New York City.....	332

GASHOLDER TANKS.	
W. C. Whyte, New York City.....	324
GAS FIXTURES.	
Mitchell, Vance & Co., New York City.....	328
COKE CRUSHER.	
C. M. Keller, Columbus, Ind.....	337
B. J. Allen, Newark, New Jersey.....	337
COAL HANDLING MACHINERY.	
C. W. Hunt Company, New York City.....	324
GAS BAGS.	
Peerless Manuf'g Co., New York City.....	324
BOOKS, ETC.	
English Journal of Gas Lighting.....	324
Gas as a Source of Light, Heat and Power.....	328
Goodwin's Directory of Gas Light Companies.....	336
The Chemist's Assistant.....	332
King's Treatise.....	338
Scientific Books.....	338
Management of Small Gas Works.....	332
Newbiggin's Gas Manager's Handbook.....	338
Gas vs. Electricity.....	324

WANTED,

Superintendent for Small Gas Works in Southern Town.

Party must be capable of operating works and constructing machinery and appliances. Letters unaccompanied by testimonials as to character, experience, and ability will not be considered. Applicants will state salary expected. Address 670-1t "C," care this Office.

Superintendent's Position Desired,

By a young man of several years experience in the manufacture and distribution of coal gas. Best of references given. 669-2 Address "P. B.," care this Office.

Superintendent's Position Desired

By a practical man of twenty-five years' experience in the manufacture and distribution of coal and water gas. Satisfactory references given. Address 646-tf "ENGINEER," care this Office.

WANTED,

Bound Copies of the English "Journal of Gas Lighting," for years 1884-5-6. Also, Bound Copies of the "American Gas Light Journal," for years 1884-5-6. "King's Treatise" complete. 670-tf EMERSON McMILLIN, Columbus Ohio.

FOR SALE.

The St. Paul (Minn.) Gas Light Company desires to enlarge its works, and offers for sale the following apparatus, which is in perfect condition:

- Six Benches of 6's.
 - Four Benches of 5's.
 - One Scrubber, 4 ft. 6 in. by 4 ft. 6 in. by 15 ft.
 - One 10-inch Exhauster.
 - Four 8 by 12 Purifiers, 10-inch connections.
 - Two 8-Horse Power Boilers.
 - One 4-Horse Power Engine.
 - One Coke Crusher.
- THE ST. PAUL GAS LIGHT CO., 670-4t E. I. FROST, Sec. & Treas.

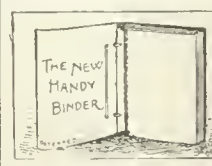

THE NEW HANDY BINDER.

This article may be described as elegant in appearance, strong, durable, and possessing many special qualities of its own. It allows the opening of the pages perfectly flat, whether one or several numbers are in the binder. Any number can be taken out and replaced without disturbing the others. The papers are not mutilated for subsequent binding in permanent form. The binder is supplied with gilt side title, and is an ornament to any desk or reading table. The JOURNAL, filed in the Handy Binder, becomes a volume of great value, always convenient for instant reference. Handy Binder, Postage paid, \$1.00. A. M. CALLENDER & CO., 42 Pine St., N. Y.

FOR SALE,

Ten No. 2 Siemens Regenerative Gas Lamps,
With Factory Fixtures and Reflectors complete and in order.
Only used three or four months. Will be sold cheap.
DANVILLE NAIL AND MFG. CO.,
Danville, Pa.

C. W. HUNT CO.,

No. 111 Broadway, N. Y. City.

MANUFACTURERS OF

Coal Handling Machinery,

AUTOMATIC RAILWAY, HOISTING ELEVATOR,
CABLE RAILWAY, STEAM SHOVEL, HOISTING
ENGINES, COAL TUBS, COAL & COKE CARS.

Plans and Specifications made for the

Erection of Coal Storage Buildings

Send for a Descriptive Pamphlet.

GAS vs. ELECTRIC LIGHT.

We would invite attention to the able and exhaustive
argument of General A. Hickenlooper, President of the
Cincinnati Gas Light and Coke Company, contained in a
handsome pamphlet of 96 pages, entitled

"EDISON'S INCANDESCENT ELECTRIC LIGHTS FOR STREET
ILLUMINATION. REPORT OF AN ARGUMENT DELIV-
ERED BY A. HICKENLOOPER BEFORE THE COMMITTEE
ON LIGHT, MUNICIPAL COUNCIL, CITY OF CINCINNATI,
JULY 22, 1886."

This is a subject of special interest to all Gas Light Com-
panies.

Prices.

25 copies.....	\$7.50	100 copies.....	\$22.50
50 copies.....	12.50	250 copies.....	50.00

A sample copy will be sent by mail on receipt of 50 cts.
A. M. CALLENDER, & CO., 42 PINE ST., N. Y. CITY.

THE GLOBE
STREET LAMP.



MINER'S PATENT
STREET LAMPS.

Are adapted for use of Streets, Parks,
Depots, Ferries, & Private Grounds.

WITH POSTS OR BRACKETS.

Jacob G. Miner,

No. 823 Eagle Ave., New York, N. Y.

Improved Patent
GAS BAG OR
BLADDER VALVE.

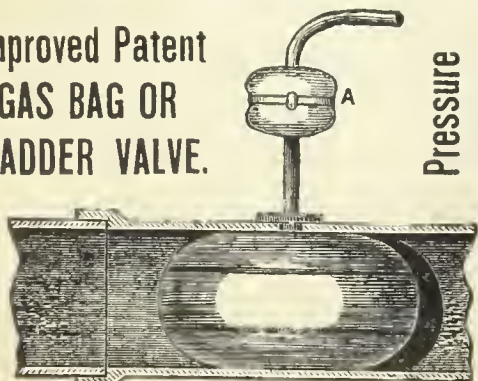

Pressure
Indicator.

MANUFACTURED BY

PEERLESS MFG. CO., 34 Murray St., N. Y.

GAS WORKS FOR SALE.

A RARE CHANCE.

The owner will dispose of the controlling interest in a gas works
in a growing Western city, on account of declining health and
inability to attend to the business. For particulars address
665-6 P. O. Box 825, Appleton, Wis.

ALBO-CARBON FIXTURES FOR SALE.

Three 12-Burner, Two 8-Burner, and Four-
teen 6-Burner Clusters.

All in good order, having been used but six months. Will be
sold cheap. For particulars communicate with

E. G. PRATT, Supt. N. Attleboro Gas Lt. Co.,
North Attleboro Mass.

FOR SALE,

Two Sinuous Friction Condensers,

Each 1 ft. 3 in. wide by 11 ft. 3 in. long, and 18 ft. high, of suffi-
cient capacity for 225,000 cu. ft. per day. Apply to
665-12 PETER COFFEY, Supt. Gas Co., Peoria, Ill.

JARVIS ENGINEERING CO.,

61 Oliver St., Boston, Mass.

CONTRACTORS FOR ERECTING

**COMPLETE STEAM OUTFITS FOR ELECTRIC
LIGHTING STATIONS.**

Steel Boilers set with Jarvis Pat. Boiler Setting,

To burn **COKE SCREENINGS** for Fuel.

ARMINGTON & SIMS CO. ENGINES,

Belting direct to Dynamos, without using Shafting.

SEND FOR CIRCULARS.

REFERENCES.—Charlestown Gas & Electric Light Co., Charlestown,
Mass.; Schenectady Gas & Electric Light Co., Schenectady,
N. Y.; Brookline Gas Co., Brookline, Mass.

ENGLISH

"Journal of Gas Lighting."

Issued weekly. New volume commences Jan. 1, 1887. Price, \$7
per annum. Subscriptions taken by

CHARLES NETTLETON, Agent for U. S.

No. 115 BROADWAY, N. Y. CITY.

KLOENNE & BREDEL

IMPROVED REGENERATIVE FURNACES.

Self-Sealing Mouthpieces & Bridge-Pipes, Retort Houses,

WASHER-SCRUBBERS,

Gasholders, and Complete Gas Works.

Refers, by permission, to Mr. Eugene Vanderpool, of Newark, N. J.; Mr. E. G. Cowdery, of
Milwaukee, Wis.; and Mr. Theo. Forstall, of Chicago, Ill. For further information apply to

FRED. BREDEL, 332 East 17th St., N. Y. City.

MUNICH REGENERATIVE FURNACE

System Drs. Schilling and Bunte.

Greatest Durability! Minimum of Attention!

COMPLETE DISTILLATION IN 3½ HOURS.

Ten to Thirteen Pounds of Coke to Hundredweight of Coal.

NO CLINKER. NO CARBONIC OXIDE IN THE REGENERATIVE FLUES.

Almost Automatic in Action.

The Most Successful Regenerative Furnace in Use.

BARTLETT, HAYWARD & CO.

Agents for the United States.

"RUSTLESS" IRON WATER PIPE.

RUSTLESS

Send for New Catalogue.

RUSTLESS

The **WELLS RUSTLESS IRON COMPANY,**

Nos. 7 and 9 Cliff Street, New York City.

GASHOLDER TANK CONSTRUCTION, ETC.

Gas Companies and others about to erect Gasholders will find it profitable to consult W. C. WHYTE,
who for over thirty years has made a specialty of

Holder Tank Excavation and Mason Work.

Fifty tanks now in operation show the sort of work done. Address

W. C. WHYTE, No. 15 Cortlandt St., N. Y. City.

THE ALBO-CARBON LIGHT!

The Perfection of Gas Lighting.

Producing the Highest Illumination yet obtained from Gas, and

EFFECTING A SAVING IN ITS CONSUMPTION.

It has been most effective in

Replacing Electricity,

AFFORDING A

SOFT WHITE LIGHT

OF EXTREME BRILLIANCY & POWER.

It has been most successful in

Supplanting Kerosene,

Giving Increased Light, Less Heat, and Perfect Safety

WITHOUT ADDITIONAL COST.

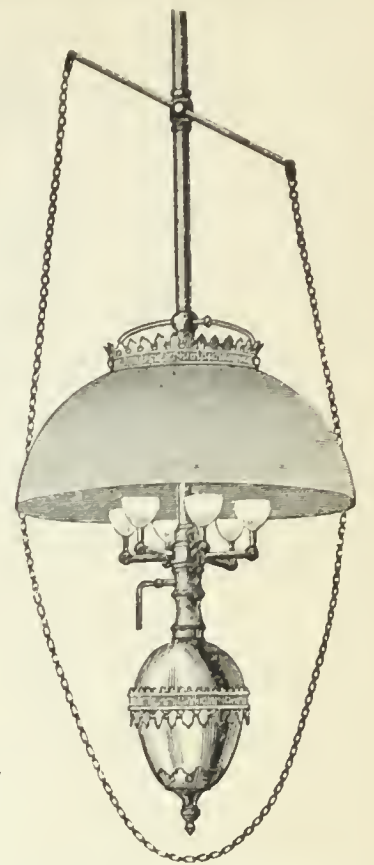
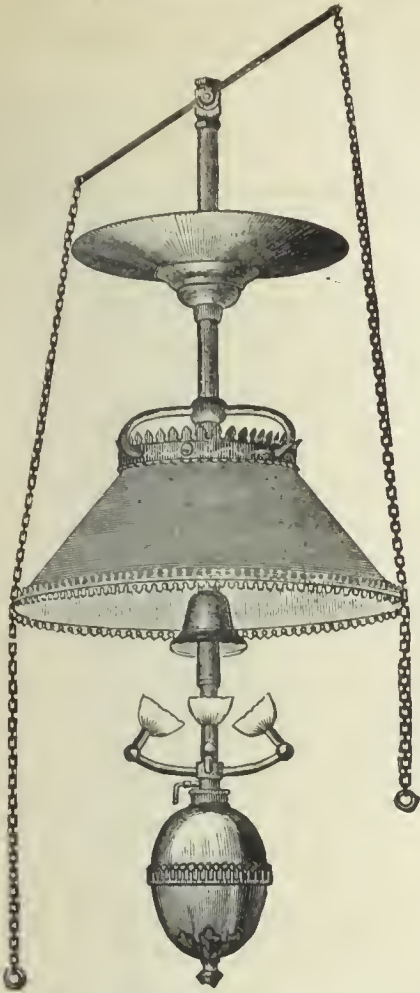

NOTICE.—Suits are pending in the United States Circuit Courts in Illinois and Pennsylvania against various parties for infringement of our Letters Patent No. 247,925, dated October 4, 1881, and No. 333,862, dated January 5, 1886. The first of these suits has come up for hearing, and an injunction has been granted therein. The second of said suits has not yet been reached for hearing. All persons are cautioned against manufacturing, selling, or using any apparatus or material which infringes our Patents. We intend to prosecute all parties infringing patents owned by us.

THE ALBO-CARBON LIGHT COMPANY, - - - NEWARK, N. J.,
Sole Manufacturers for the United States.

DURING THE PAST YEAR, THE

NATIONAL GAS LIGHT AND FUEL CO.

218 LA SALLE ST., CHICAGO,

Have Erected Twelve Sets of Water Gas Generating Apparatus under the *Springer Cupola* System. They are as follows:

Newton Illuminating Company, Newton, Kansas.— Daily capacity, 120,000 cu. ft.

Wellington Light & Heat Co., Wellington, Kansas.— Daily capacity, 120,000 cu. ft.

Chippewa Falls, Gas Light Co., Chippewa Falls, Wis.— Daily capacity, 120,000 cu. ft.

Elkhart Gas Light & Coke Co., Elkhart, Indiana.— Daily capacity, 120,000 cu. ft.

Madison City Gas Light Company, Madison, Wis.— Daily capacity, 120,000 cu. ft.

South Bend Gas Light Co., South Bend, Indiana.— Daily capacity, 250,000 cu. ft.

Sheboygan National Gas Comp'y, Sheboygan, Wis.— Daily capacity, 120,000 cu. ft.

Salina Gas Light Company, Salina, Kansas.— Daily capacity, 120,000 cu. ft.

Rathbun Company, Deseronto, Province Ontario.— Daily capacity, 80,000 cu. ft.

Jefferson City Gas Light Co., Jefferson City, Mo.— Daily capacity, 120,000 cu. ft.

Mankato Gas Light Company, Mankato, Minnesota.— Daily capacity, 80,000 cu. ft.

Minneapolis Gas Lt. & Coke Co., Minneapolis, Minn.— Daily capacity, 1,000,000 cu. ft.

1886

1886

EXHAUSTERS.

EXHAUSTERS.

EXHAUSTERS.

THE ROOTS GAS EXHAUSTER.

CINCINNATI, OHIO, March 24, 1887.

P. H. & F. M. Roots, Connersville, Ind.: Gentlemen—I have the honor to say that after the continuous and uninterrupted use of your Exhausters for a period of fifteen years, it affords me pleasure to endorse them in the highest possible terms.

Very respectfully,

A. HICKENLOOPER, Prest. Cincinnati Gas Co.

CINCINNATI GAS LIGHT AND COKE CO., Cincinnati, Ohio, two No. 6 Gas Exhausters, with Engine, for their new works, which, with the two No. 6 Exhausters, without Engines, at their old works, and one No. 3, with Engine for pumping, for their station at Carthage, make five Exhausters in all for this Company.

CHICAGO, ILL., March 24, 1887.

Messrs. P. H. & F. M. Roots, Connersville, Ind.: Dear Sirs—We have two of your No. 6 Exhausters at our works, which have been running for several months, and are giving very good satisfaction.

Yours truly,

THEO. FORSTALL, Prest.

THE CHICAGO GAS LIGHT AND COKE CO., Chicago, Ill., two No. 6 Gas Exhausters and Engine combined on same bed-plate.

St. Louis, Mo., March 21, 1887.

Messrs. P. H. & F. M. Roots, Connersville, Ind.: Dear Sirs—In 1872 one of your No. 5 Exhausters was placed in these works, and worked satisfactorily. March, 1885, it was replaced by one of your No. 6 Exhausters. The latter has been in almost constant use the past two years, has worked up to all my expectations, and is to-day in apparently as good condition as when first set up. It has not cost one cent for repairs in all that time. I have also had one of your No. 1 Exhausters, with Engine on same bed-

plate, fitted with your valves and Huntoon Governor, placed in a small works under my control, and in its operation it seems as near perfection as I ever expect an Exhauster to become. Without in the least disparaging Exhausters of other makes, I may say that your Exhauster may be safely recommended as unsurpassed by any other, to those requiring such machines.

Yours respectfully,

FREDERIC EGNER, Eng. and Supt.

CLEVELAND, OHIO, March 22, 1887.

Messrs. P. H. & F. M. Roots, Connersville, Ind.: Gentlemen—Concerning the Exhauster furnished this Company by you last fall, I can say but little—indeed, much need not be said. It simply does its work perfectly, and in a way that inspires confidence that it will not shirk its duty when one's back is turned. If I wanted another 1,000,000 capacity I should try and duplicate our No. 4.

Very respectfully,

EDWARD LINDSLEY, Eng. and Supt.

PEOPLES GAS LIGHT CO., Cleveland, Ohio, one No. 4 Exhauster and Engine combined on same bed-plate, Pipe Fittings, Gas and Bye-Pass Valves, Governor, etc.

INDIANAPOLIS, IND., March 21, 1887.

P. H. & F. M. Roots, Connersville, Ind.: Gentlemen—The No. 4 Exhauster and Engine which you erected for us last summer has done all you claimed for it, and has given us perfect satisfaction.

Yours very truly,

JAS. SOMERVILLE, Eng. and Supt.

INDIANAPOLIS GAS LIGHT CO., Indianapolis, Ind., one No. 4 Gas Exhauster and Engine combined on same bed-plate, Pipe Fittings, Gas and Bye-Pass Valves, etc. This Exhauster has a capacity of 1,000,000 cu. ft.

P. H. & F. M. ROOTS, Patentees and Manufacturers, CONNERSVILLE, IND.

S. S. TOWNSEND, Gen. Agt., 22 Cortlandt St., N. Y.

COOKE & CO., Selling Agts., 22 Cortlandt St., N. Y.

SMITH & SAYRE MFG. COMPANY,

G. PORTER, Prest.

245 Broadway, N. Y. CHAS. W. ISBELL, Sec'y.

Machinery & Apparatus for Gas Works

Drawings, Plans, and Estimates Furnished for the Improvement, Extension, or Alteration of Gas Works, or for the Construction of New Works.

Mackenzie's Patent Rotary and Steam Jet Gas Exhausters, Governors, Compensators, Condensers, Washers, Scrubbers. Isbell's Patent Automatic Street Pressure Governor, Gas and Water Valves, Hydraulic Main Dip Regulator, Bench Castings, etc. Purifying Boxes and "Standard" Scrubbers. Isbell's Patent Self-Sealing Retort Doors.

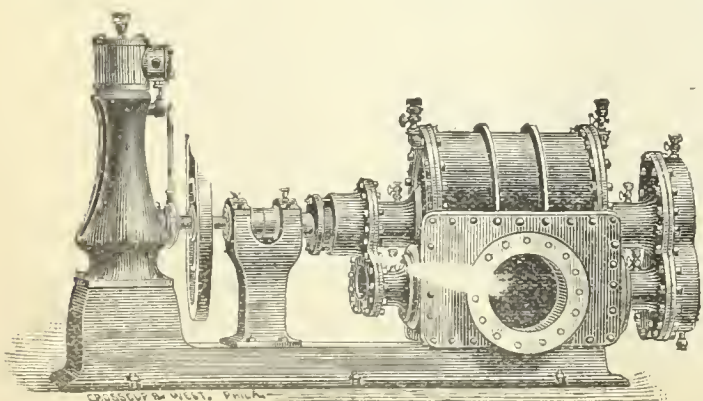
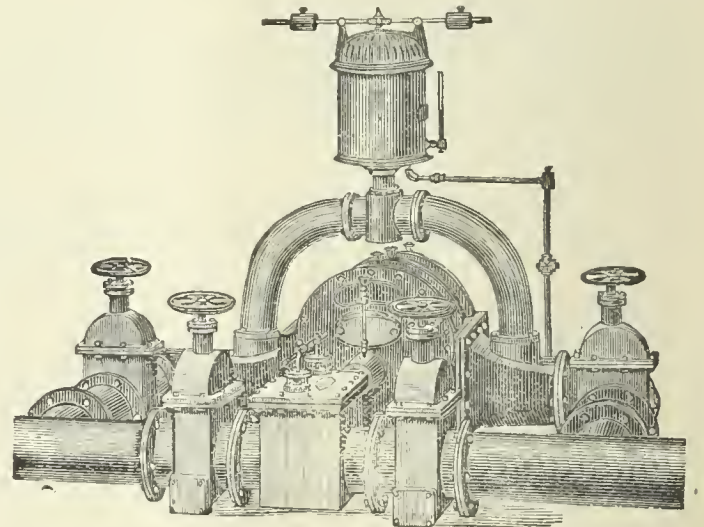

The Wilbraham Gas Exhauster,

"BAKER SYSTEM,"

WITH ENGINE ATTACHED, ON SAME BED PLATE OR WITHOUT.

Best, Cheapest and Most Durable Exhauster known.

WILBRAHAM BROS.,

No. 2320 Frankford Avenue, Philadelphia, Pa.

CONNELLY & CO, LTD.**KIND WORDS,****UNSOLICITED BUT NOT UNEXPECTED.**

We beg the attention of our friends and the gas fraternity generally to the following letter, from Mr. F. H. Hambleton, Engineer Consolidated Gas Light Company, Baltimore, Md., giving a tardy but all the more valued report of his experience with *three* of our twenty-inch and *one* six-inch Governors, after nearly *two years' use*. Having *four* Governors, large and small, working under different conditions, gives Mr. Hambleton's letter special significance and weight.

CONNELLY & CO., Ltd., 177 Broadway, N. Y.

BALTIMORE, MD., April 25th, 1887.

CONNELLY & Co., Ltd., 177 Broadway, New York:

Gentlemen—Inclosed you will find some cards from the Automatic Governors you supplied us in 1885. You no doubt feel that we have been very slow in making any statement as to the working of your Governors, but it is our rule to let things work out their own salvation; and when they have established the habit of doing their work in a certain way we are willing to give the results. The cards are from a district which is not disturbed by pumping, and the Governor is absolutely automatic, and *is not touched for a year at a time*. I send one card of December, 1886, to show the putting on of the morning pressure, and the cards of this month are to show the difference between Saturday and Sunday. The six-inch Governor works well, and the other twenty-inch ones work perfectly, when we are not pumping between stations in the daytime. When we are pumping we want a large volume to pass without putting on the night pressure. In conclusion, I may say that they are the best Governors in the market.

Very respectfully,

F. H. HAMBLETON, Engineer.

To All Whom It May Concern!

The SIEMENS-LUNGREN COMPANY hereby warns the public against the use of various infringing Regenerative Gas Lamps which are offered for sale. This Company has heretofore delayed bringing suit to enjoin the manufacture or importation of such infringing lamps, solely because of the practical worthlessness of the infringing devices; and although, in each instance, they infringe some one or more of the various patents owned or controlled by this Company, they have fallen into disuse sooner than any suit could be brought to a hearing. As, however, the introduction of these infringing lamps has tended to discredit the practicability of our Company's system of regenerative gas lighting, we have instructed our Attorneys, Messrs. Geo. Harding, C. S. Whitman, and Silas W. Pettit, to give notice that legal proceedings will in future be taken against all such infringers.

THE SIEMENS-LUNGREN CO., 21st St. & Washington Av., Phila., Pa.

THE CLERK GAS ENGINE CO.,

Main Office, 1012, 1014, 1016, 1018 Filbert St., Philadelphia, Pa.

WM. W. GOODWIN, Prest.

E. STEIN, Sec.

S. LEWIS JONES, Asst. Sec.

A. J. DOTY, Supt.

The utility and convenience of the Gas Engine being no longer an open question, it only remains now for intending purchasers to select the BEST. We claim for the CLERK GAS ENGINE that it is equal to any other manufactured as regards steadiness in running, simplicity, and ease of keeping in repair, and that it gives the greatest amount of power for the least money (both in first cost and expense of running) of any engine made. In support of this claim we refer to the test of the Gas Engines made under the direction of the American Institute of New York, in December, 1885, and heretofore published in these columns. These engines are especially adapted for continuous running under heavy loads, and we can refer to Engines which have run 22 hours a day for months at a time.

Made in Sizes of 5, 10, 15, 20, and 25 Horse Power. All Engines Guaranteed for One Year.



CHAPMAN VALVE MANUFACTURING CO.,

MANUFACTURERS OF

Valves and Gates for Gas, Ammonia, Water, Etc.

Also, Gate Fire Hydrants With and Without Independent Nozzle Valve. All Work Guaranteed.

WORKS & GEN'L OFFICE:
Indian Orchard, Mass.

TREASURER'S OFFICE:
72 Kilby & 112 Milk Sts, Boston, Mass.

LUDLOW VALVE MFG. CO.

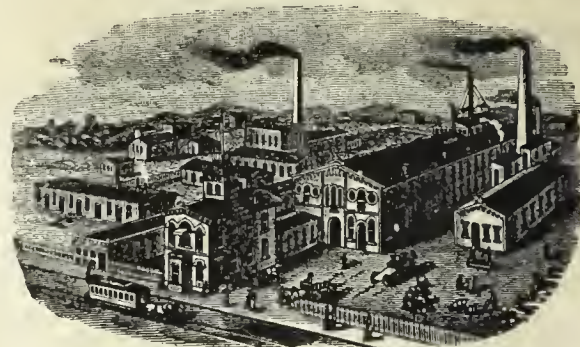

OFFICE AND WORKS,

938 to 954 River Street and 67 to 83 Vall Av.
TROY, N. Y.

**T. C. HOPPER'S
AUTOMATIC DIFFERENTIAL GAS GOVERNOR**

Is now in Practical Operation, doing Perfect Automatic Service with Great Precision.

This Governor will do all and more than any other Governor on the Market.

BE SURE TO THOROUGHLY INVESTIGATE THE SUPERIOR MERITS OF THIS GOVERNOR BEFORE PURCHASING.

For Simplicity and Reliable Work it has no Equal. Correspondence Solicited.

T. C. HOPPER & CO., - - Manufactory, 2227 Wood Street, Phila, Pa.

Hydraulic Main Dip Regulators, also
Check Valves, Foot Valves, Yard-
wash and Fire Hydrants.
Send for Circulars.

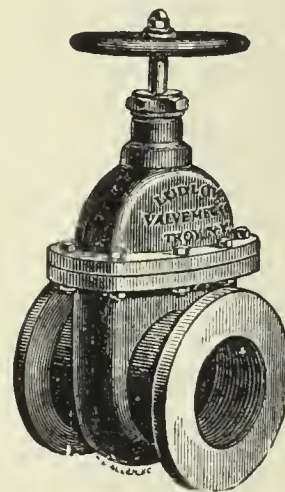

Valves.—Double and Single Gate, 3 in. to
48 in., outside and inside Screws. Indica-
tor, etc., for Gas, Water, Steam, and Oil.
Send for Circulars.

G. S. COOK, Pres. THOS. DAVENPORT (late Davenport Bros.), Sec. & Treas

**BARTLETT
Street Lamp Mfg. Co.**

MANUFACTURERS OF

Bartlett's Patent

GLOBE LAMPS,

FOR

Streets, Parks, Railroad Stations, Public Buildings, Etc.

LAMP POSTS A SPECIALTY.

Office and Salesroom

40 & 42 College Place, N. Y. City.

Gas Companies and others intending to erect lamps and posts will do well to communicate with us.

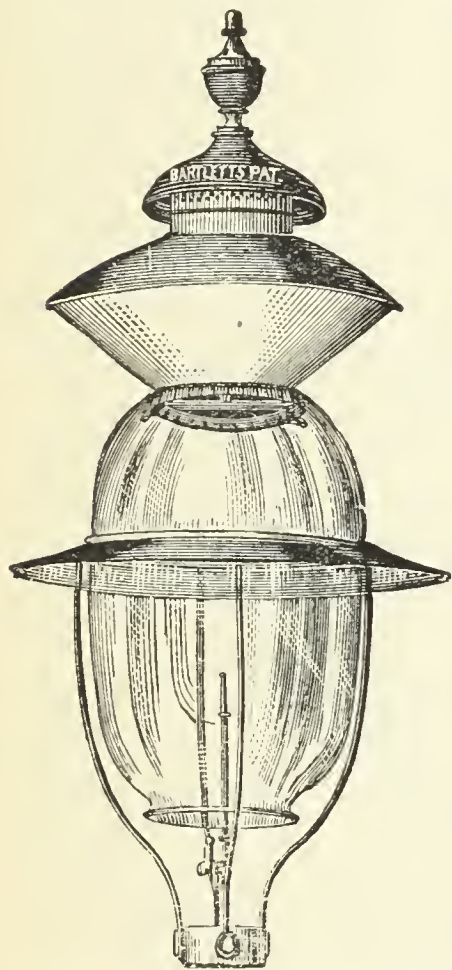

John McLean
Man'facter of
GAS VALVES.
298 Monroe Street, N. Y.

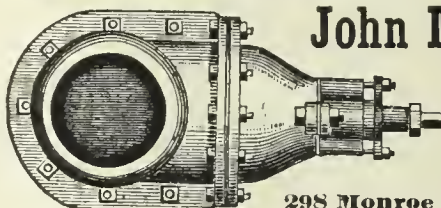

MITCHELL, VANCE & CO.,
MANUFACTURERS OF
Chandeliers
and every description of
GAS FIXTURES.

Also manufacturers of Fine Gilt Bronzes and Marble Clocks, warranted best time-keepers. Mantel Ornaments, etc.

Salesrooms, 836 Broadway, N. Y.

Special Designs furnished for Gas Fixtures for Churches, Public Halls, Lodges, etc.

GAS AS A SOURCE OF LIGHT, HEAT, AND POWER.

By C. J. R. HUMPHREYS

A Pamphlet of twenty-nine pages, treating of the use of Gas as a source of Light, Heat, and Power.

DESIGNED FOR DISTRIBUTION BY GAS COMPANIES AMONG THEIR CUSTOMERS AND OTHERS.

Price, 10 cents each, \$5 per 100, \$50 per 1,000.

Gas Companies can have their own imprint placed on cover without extra charge. All orders to be sent to

A. M. CALLENDER & CO.,
No. 42 Pine Street, N. Y. City.

GAS STOVES.

GAS STOVES.

GAS STOVES.

THE AMERICAN METER CO.,

MANUFACTORIES,

508 to 514 West Twenty-second St., N. Y.

Arch and Twenty-second St., Phila.

Nos. 244 & 246 North Wells Street, Chicago, Ill.

AGENCIES,

No. 177 Elm Street, Cincinnati, Ohio.

Nos. 122 & 124 Sutter Street, San Francisco Cal

No. 810 North Second Street, St. Louis, Mo.



New Design Cast Iron "Economy" Cabinet Stoves.—With Open or Closed Top.

THE COMPANY MANUFACTURES

GAS STOVES FOR COOKING AND HEATING PURPOSES,

In All Sizes, for Domestic, Restaurant, and Hotel Use.

Also,

A Variety of Apparatus for Mechanical Purposes, Using Gas as Fuel.

These Stoves may be seen in operation at our Retail Store, No. 223 Sixth Avenue, N. Y. Call and examine.

SEND FOR ILLUSTRATED CATALOGUE SHOWING THE VARIOUS STYLES AND SIZES.

RETORTS AND FIRE BRICK.

J. H. GAUTIER & CO.,
CORNER OF
GREENE AND ESSEX STREETS,
JERSEY CITY, N. J.

MANUFACTURERS OF
**Clay Gas Retorts,
Gas House Tiles,
Fire Bricks, Etc. Etc.**

Ground Clay, Fire Brick and
Fire Sand in Barrels,

J. H. GAUTIER. T. B. GAUTIER.
C. E. GREGORY. C. E. GAUTIER.

BROOKLYN
Clay Retort & Fire Brick Works,
(EDWARD D. WHITE & CO.)
Manufacturers of Clay Retorts, Fire Brick,
Gas House and other Tile.
VAN DYKE, ELIZABETH, RICHARDS & PARTITION STS.
Office, 88 Van Dyke St., Brooklyn, N. Y.

RETORTS AND FIRE BRICK.

LAGLEDE FIRE BRICK MFG. CO.,
MANUFACTURERS OF
Fire Brick, Gas Retorts,

AND
ST. LOUIS STANDARD SEWER PIPE.
Blast Furnace and Cupola Linings, every description of Fire
Clay Material, Fire Clay Flue Linings, Chimney Tops
Dry Milled and Crude Fire Clays, etc.

OFFICE AND DEPOT
901, 903, and 905 Pine Street,
ST. LOUIS, MO.

ESTABLISHED IN 1845.

B. KREISCHER & SONS,

OFFICE FOOT OF HOUSTON ST., E. R., N. Y.

Gas Retorts,

TILES, FIRE BRICK.

AND EVERYTHING IN THE FIRE CLAY LINE.

RETORTS AND FIRE BRICK.

MANHATTAN
FIRE BRICK & ENAMELLED CLAY
RETORT WORKS.
ADAM WEBER.

**CLAY GAS RETORTS
AND RETORT SETTINGS
FIRE BRICKS, TILES, ETC.,**

Office and Works, 15th Street and Avenue C., N. Y.



Works,
LOCKPORT STATION, PA.

—ESTABLISHED 1864.—

JAMES GARDNER, JR.,

Successor to WILLIAM GARDNER & SON.

Fire Clay Goods for Gas Works.

CHAS. H. SPRAGUE & SON, No. 70 KILBY STREET, BOSTON, MASS., Agents for the New England States.

Office, Rooms 19 & 20, Lewis Block,
PITTSBURGH, PA, P. O. Box 373.

OFFICE, 418 to 422 East 23d St., New York.

ESTABLISHED 1856.

WORKS, PERTH AMBOY, NEW JERSEY.

HENRY MAURER & SON,
Excelsior Fire Brick & Clay Retort Works
CLAY GAS RETORTS, BENCH SETTINGS, FIRE BRICK, TILES, ETC.

CHICAGO
Retort & Fire Brick Works,
OFFICE AND FACTORY,
Clark, Forty-Fifth, and La Salle Streets,
CHICAGO, ILL.
GEORGE C. HICKS, PRES. PAUL P. AUSTIN, SEC. & TREAS.
STANDARD
Clay Retorts and Settings.
BLOCKS & TILES
Of every Shape and Size to Order.
Standard Fire Bricks.

GEROULD'S IMPROVED RETORT CEMENT.
A Cement for patching retorts, putting on mouthpieces, and
making up all bench-work joints. This Cement is mixed ready-
for use. Economic and thorough in its work. Fully warranted
to stick. For recommendations and price list address
C. L. GEROULD,
Manchester, N. H.
Western Agent, H. T. GEROULD, Mendota, Ill.

OAKHILL
GAS RETORT & FIRE BRICK
Works.
Proprietors,
PARKER-RUSSELL MINING & MFG. CO.
City Office, 711 Pine Street,
ST. LOUIS, MO.

Our immense establishment is now employed almost entirely in
the manufacture of
MATERIALS FOR GAS COMPANIES.
We have studied and perfected three important points. Our re-
torts are made to stand changes of temperature, the strongest
heats of the furnace, and the abrasion of feeding and emptying.
Our customers are in almost every State of the Union, to all of
whom we refer.

THOS. SMITH, Prest. AUGUST LAMBLA, Vice-Prest. & Sup
BALTIMORE
RETORT & FIRE BRICK CO.
MANUFACTORY AT
LOCUST POINT, BALTIMORE, MD.
Connection with the City by Telephone.
**Clay Retorts, Blocks & Tiles,
FIRE BRICK, FIRE CLAY,
AND FIRE CEMENT.**

Red and Buff Ornamental Tiles and Chim-
ney Tops. Drain and Sewer Pipe (from
2 to 30 inches). Baker Oven Tiles
12x12x2 and 10x10x2.
WALDO BROS., 88 WATER ST., BOSTON, MASS
Sole Agents the New England States.

RETORTS AND FIRE BRICK.

EVENS & HOWARD,

916 Market St., St. Louis. Mo.

Works, Howard Station, Mo. Pacific R.R.

Fire Brick, Gas Retorts

AND

RETORT SETTINGS.

Sewer Pipe, 3 to 24 in. diameter.

Glass Pot Clay, Ground Fire Clay, in barrels and in bulk. All kinds of Fire Clay Goods.

Cincinnati Gas Retort & Fire Brick Works.

—ESTABLISHED 1872.—

CHAS. TAYLOR,

MANUFACTURER OF

Gas Retorts, Fire Brick, and Tile.

Blast Furnace Linings, Cupola Blocks, Boiler Tiles, Grate Settings, and Stove Linings. Fire Cement, Fire Clay, Fire Sand, and all other Fire Clay Goods.

Branch Works, New Cumberland, W. Va.

GENERAL OFFICE AND WORKS,

Burns St., Cincinnati, Ohio.

Stettiner

Chamotte Fabrik Actien Gesellschaft,

Formerly **DIDIER,**

(Patentees of the Dr. Schilling & Dr. Bunte Regenerative Furnace)

STETTIN, GERMANY.

The attention of all Gas Engineers is called to our Fire-Proof Material, viz.:

CLAY GAS RETORTS

(ENAMELED AND UNENAMELED),

Blocks, Tiles

AND

EXTRA FIRE BRICK,

Pronounced by the highest authorities as superior to and excelling any other similar manufacture. The component of aluminum contained in our material (up to 45 per cent.) is larger than in any other material heretofore sold in the United States; whilst the uniformity of the goods is assured by the most scrupulous analysis of the clay used.

For any further information and prices please apply to

EMIL LENZ,

2 & 4 Stone St., Room 19, N.Y. City.

PATENTS.

FRANKLIN H. HOUGH,

Solicitor of American & Foreign Patents

925 F. ST., WASHINGTON, D. C.

(NEAR U. S. PATENT OFFICE.)

Personal attention given to the preparation and prosecution of applications for Letters Patent. All business before the U. S. Patent Office attended to for moderate fees. **No Agency in the United States possesses superior facilities for obtaining Patents,** or for ascertaining the patentability of inventions. Copies of patents furnished for 25 cents each. Correspondence solicited.

GAS LAMPS.

STEPHEN A. MORSE, President.
GODFREY REBMANN, Vice-Pres.

M. B. DYOTT,
Superintendent.

EDWIN F. MORSE, Secretary.
CARLTON M. WILLIAMS, Treas.



STANDARD GAS LAMP CO.,

Office, 411 Cherry St. Factory, 1101, 1103 & 1105 Frankford Av.

Philadelphia, Pa.

It is to the interest of Gas Companies and Cities to use Dyott's Patent Champion Lamps, which give double the light with the same consumption of gas, and will save 50 per cent. over others in cost of keeping in repair. Gas Companies and others intending to erect Lamps of any description will do well to communicate with us. Special Drawings furnished and Estimates given on application upon Architects', Engineers' or our Draughtsmen's Plans.

Our Patent System of Instantaneously Lighting Gas (without electricity) for R. R. Depots is unequalled. Our High Candle Power Burner is superior to the Electric Light or any other High Candle Burner. We manufacture every description of Ornamental Lamps.

WONDERFUL GAS LIGHT!

Great improvements! New inventions! Brilliant success! Brilliant light! Over 500,000 of the Gas Lamps and Burners designed by GEO. H. GREGORY now in practical use. Send for Catalogue. Prices reduced on all goods in order that Gas Companies will introduce the goods to the consumer at a reasonable price. Over one hundred Gas Companies are selling the new lamps and burners. The only way to prevent the adoption of incandescent electric light is to put on the wonderful gas lamps and burners. Address **GEO. H. GREGORY, Gas Lamp and Burner Mnfr., 389 BROADWAY, N. Y.**

CHURCH'S REVERSIBLE TRAY

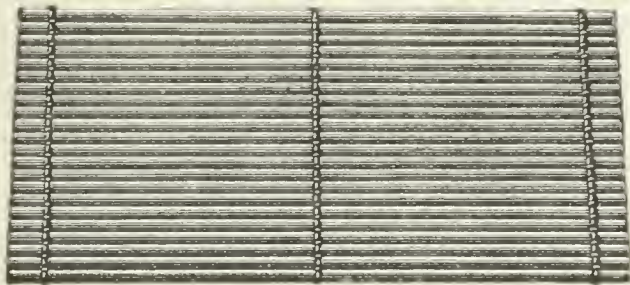

For Purifiers and Scrubbers.

OVAL OR RECTANGULAR SLATS.

FOR LIME OR IRON SPONGE.

MALLEABLE IRON CROSS BARS.

**Strongest! Most Durable!
Most Easily Repaired!**

MANUFACTURED BY

JOHN CABOT,

306 to 310 Eleventh Ave., N. Y. City.



Patented July 9, 1878, and Feb. 5, 1884.

Used by the principal Companies in every State of the Union. Price List on application.

MILLS' REVERSIBLE LIME TRAY,

AND

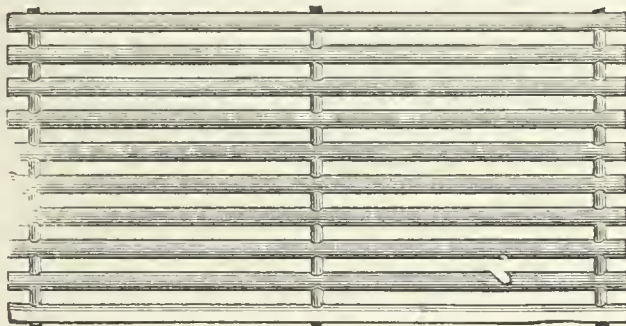

WOODWORK

Of Every Description

NEEDED BY GAS WORKS.

SEND FOR CIRCULAR AND PRICE LIST TO

GEORGE A. MILLS,

Canton Av. & President St., Baltimore, Md.

Ferric Oxide for Gas Purification.

Ferric Oxide, as ground, screened, and prepared by me for purifying purposes, has now been in use for several years by many of the gas works throughout the country, including Detroit, Chicago, Milwaukee, East Saginaw, Burlington (Iowa), Ann Arbor, etc. It has proved, as I believe, the **Most Effective and Economical Agent** now in use. I am prepared to furnish the Oxide by the 100 lbs. or in car load lots, and will be pleased to give price f.o.b. cars at Ann Arbor or at place of destination. Address

S. H. DOUGLAS, Prest. Ann Arbor (Mich.) Gas Light Co.

GAS AND WATER PIPES.

GAS AND WATER PIPES.

ENGINEERS.

SAM'L R. SHIPLEY, Pres.
HENRY B. CHEW, Treas.JAS. P. MICHELLON, Sec.
WM. SEXTON, Supt.

GLOUCESTER IRON WORKS,

GLOUCESTER CITY, N. J.



Cast Iron Gas & Water Pipes, Stop Valves, Fire Hydrants, Gasholders, &c.

Office No. 6 North Seventh Street, Philadelphia.

MATTHEW ADDY, President.

W. L. DAVIS, Selling Agent.

GEO. P. WILSHIRE, Sec. & Treas.

Cincinnati and Newport Iron and Pipe Company,

NEWPORT, KY.

Lamp Posts

AND

BENCH CASTINGS

A Specialty.

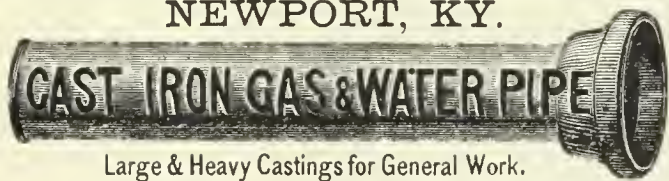

Large & Heavy Castings for General Work.

Branch

AND

SPECIAL CASTINGS

FOR GAS & WATER CO'S.

Manufacture Pipe from 2 to 48 inches. All work guaranteed first quality.

Pancoast & Rogers.

WROUGHT IRON PIPE,

VALVES AND GATES,

Cast Iron Gas & Water Pipe.

28 Platt and 15 Gold St., New York.

Parson's Steam Blower,

FOR IMPROVING BAD DRAUGHT IN BOILERS, AND FOR BURNING BREEZE OR OTHER WASTE MATERIAL.

PARSON'S TAR BURNER,

FOR UTILIZING COAL TAR AS FUEL.

PARSON'S AIR JET TUBE CLEANER,

FOR CLEANING BOILER TUBES.

These devices are all first-class. They will be sent to any responsible party for trial. No sale unless satisfactory. Manufactured by the WATERTOWN STEAM BLOWER COMPANY.

H. E. PARSON, Supt., 42 PINE ST., N. Y.

The Management of Small Gas Works.

By C. J. R. HUMPHREYS. Price, \$1.

A. M. CALLENDER & CO., 42 Pine St., N. Y.

P. D. WANNER, Chairman. A. H. MELLERT, Sec. & Treas.

MELLERT FOUNDRY & MACHINE CO., Ltd.

Reading, Pa.

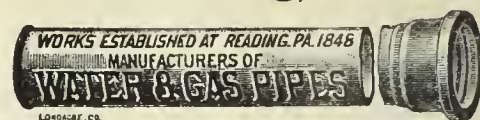

Specials—Flange Pipe, Valves and Hydrants, Lamp Posts, Retorts, etc.

General Foundry and Machine Work.

JOHN FOX, Selling Agent. 160 Broadway, N. Y.

THE OHIO PIPE COMPANY,

MANUFACTURERS OF

Cast Iron Gas & Water Pipe,

BRANCH AND SPECIAL CASTINGS.

Gas-House Bench Castings, Hydraulics, Lamp Posts, Flange Pipe and Specials, Architectural Castings, Building Columns, Joists, Cellar Grates, Sash Weights, etc.

GENERAL FOUNDERS AND MACHINISTS.

Columbus, Ohio.

M. J. DRUMMOND,



SPECIAL CASTINGS AND LAMP POSTS.

Equitable Building, 120 Broadway, N. Y.

JOS. R. THOMAS, C.E.,

May be Consulted on all Matters Relating to Gas Works and Gas Manufacture.

ADDRESS THIS OFFICE.

WM. MOONEY

(Successor to WM. FARMER)

27 Pearl Street, N. Y. City.

(One door from Whitehall Street.)

CONTRACTOR FOR THE ERECTION OF GAS WORKS, OR APPARATUS OF ANY CAPACITY. AGENT FOR WM. FARMER'S PATENTS.

Plans and Specifications Furnished.

WM. HENRY WHITE,

CONSULTING AND CONSTRUCTING

Gas Engineer & Contractor

Estimates, Plans, and Specifications furnished for new works or extensions of existing works.

No. 32 Pine Street, New York City.

Correspondence solicited.

WM. GARDNER,

Gas Engineer,

Lewis Block, Room 20, Pittsburgh, Pa.

Those who intend to make alterations in existing gas plants, or who contemplate the erection of new works, will find it to their interest to open correspondence with the above. Plans made and estimates furnished.

GAS LAMPS.

SCRUBBERS AND CONDENSERS.

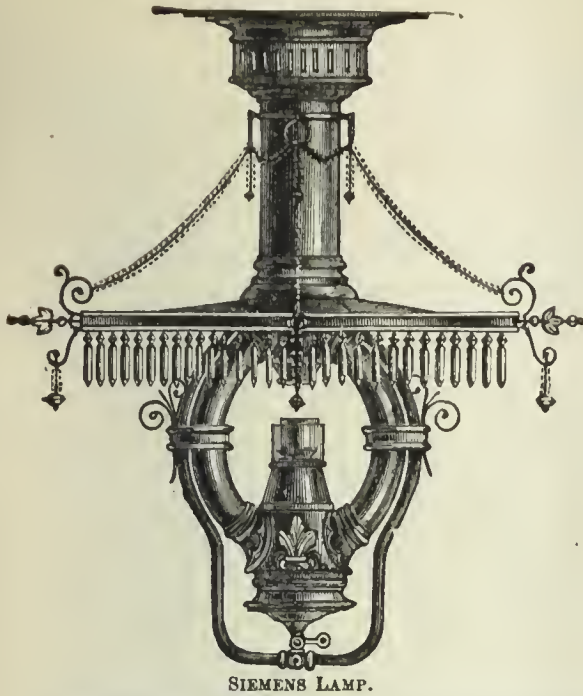

SIEMENS LAMP.

The Siemens and Lungren REGENERATIVE GAS LAMPS.

A System of Burning Gas whereby its Illuminating Power is Increased from 300 to 400 per ct. without the Expense, Trouble and Annoyance resulting from the use of Hydrocarbon Enriching Material.

The Siemens-Lungren Company received the only Silver Medal or Highest Award for Gas Burners at the "Novelties" Exhibition of the Franklin Institute, held at Phila., Oct., '85.

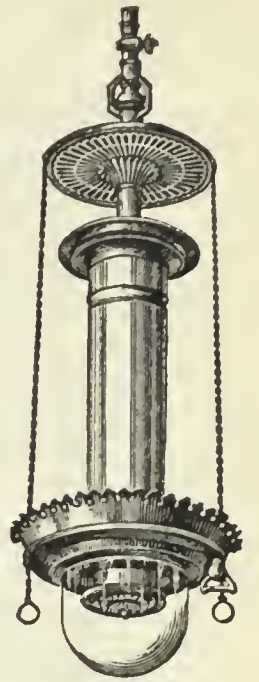

LUNGREN LAMP

THIRTEEN CANDLE POWER PER CUBIC FOOT OF GAS!

This result is obtained

SIMPLY BY THE SCIENTIFIC APPLICATION OF THE REGENERATIVE PRINCIPLE.

Consequently this largely increased illumination is always maintained without further cost and frequent attention.

THE SIEMENS-LUNCREN COMPANY,

N. E. Cor. 21st. St. and Washington Av., Phila., Pa.

THE PATENT "STANDARD" WASHER-SCRUBBER

(KIRKHAM, HULETT & CHANDLER PATENT.)

Has been adopted by gas companies in all parts of the world. Between 300 and 400 companies, with the enormous daily output of over 300,000,000 cubic feet, are now using it. "Standard" Washer-Scrubbers have been erected for the following gas light companies since Jan. 1, 1886:

WALLASEY, ENGLAND.....	750,000 cubic feet.	RICHMOND, SURREY, ENGLAND.....	1,500,000 cubic feet.
NEWARK, ENGLAND.....	350,000 "	BRIDGEPORT, U. S.....	500,000 "
BUFFALO, U. S. (MUTUAL).....	500,000 "	TORONTO, CANADA.....	1,000,000 "
BERLIN, GERMANY.....	1,250,000 "	HARTFORD, U. S.....	1,000,000 "
SO. BRISBANE, AUSTRALIA.....	300,000 "	DETROIT, U. S.....	750,000 "
LEEDS, ENGLAND.....	2,000,000 "	SINGAPORE, CEYLON.....	300,000 "
FURTH, GERMANY.....	400,000 "	BRUNSWICK, GERMANY.....	300,000 "
FREIBURG, GERMANY.....	200,000 "	LILLE, FRANCE.....	750,000 "
NINE ELMS, LONDON.....	3,000,000 "	CADIZ, SPAIN.....	300,000 "
MELBOURNE, AUSTRALIA (2).....	3,000,000 "	READING, ENGLAND.....	2,000,000 "
GLUCKAUF COKE WORKS, GERMANY.	200,000 "	LINCOLN, U. S.....	250,000 "
BOURNEMOUTH, ENGLAND.....	1,000,000 "	ST. LOUIS, U. S. (LACLEDE).....	1,000,000 "
		BROOKLYN, U. S.....	2,000,000 "
		BROOKLYN, U. S. (NASSAU).....	1,000,000 "

That this apparatus is really the *standard* is indicated by the following names of important houses who represent this invention in the different countries of the world:

FRANCE & BELGIUM, Mons. J. A. Berly, 31 Rue Boinod, Paris. HOLLAND & DUTCH COLONIES, Mess. W. Hoven & Zoon, Rotterdam.

GERMANY and AUSTRO-HUNGARY, Berlin-Anhaltische-Actiengesellschaft, Berlin, Moabit, and Dessau.

RUSSIA, Mr. F. Bley, Galernaya, 44, St. Petersburg. SPAIN, Mess. Nicolas, Chamon, Foiret & Cie., 29 Rue Claude-Vellefaux, Paris.

ITALY & MALTA, Sig. E. Canziani, 26 & 28 Portici, Vittorio Emmanuele, Genoa. Sig. Fratelli Scheuer, Via Chiaja, 124, Naples

NEW SOUTH WALES, Messrs. W. Coward & Sons, 143 Queen Victoria St., London.

NEW ZEALAND and VICTORIA, Messrs. G. D. Jennings & Co., 28 Gracechurch St., London.

Companies in the U. S. adopting this apparatus can now be assured of a market for the Ammoniacal Liquor at a remunerative price. Correspondence for purchase of "Standards" and Ammoniacal Liquor is solicited by the

GEO. SHEPARD PAGE, 69 WALL STREET, NEW YORK.

GAS WORKS APPARATUS AND CONSTRUCTION.

GAS WORKS APPARATUS AND CONSTRUCTION.

WORKS: { MILLVILLE, N. J.
FLORENCE, "
CAMDEN, "

R. D. WOOD & CO.,

OFFICES: { 400 CHESTNUT ST.,
PHILADELPHIA.

CAST-IRON PIPE 1½ to 72 Inches in Diameter.

Water Machinery and Gas Apparatus.

HEAVY CASTINGS.

HOLDERS,

LAMP POSTS,

VALVES,

PURIFIERS,

CONDENSERS,

BENCH WORK,

METER CASES.

FLOORS AND ROOFS,

FLANGED PIPE,

FIRE HYDRANTS,

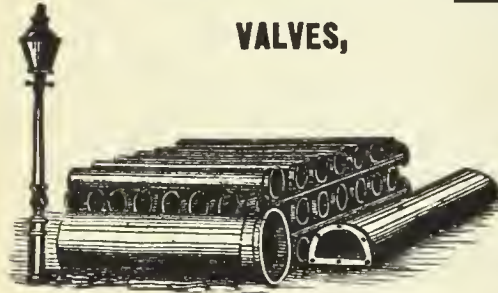

Estimates and Specifications for
NEW WORKS or **EXTENSIONS**
or **ALTERATIONS** of **OLD ONES.**

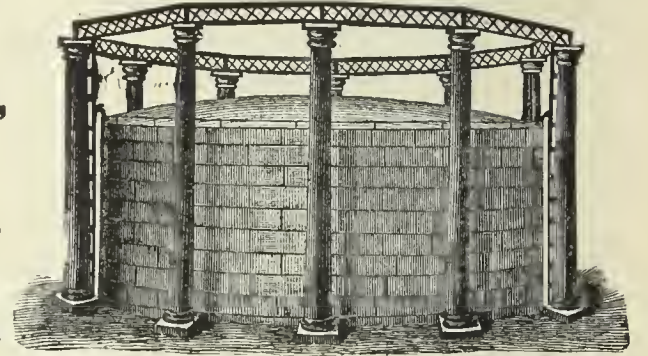

SOUTHWARK FOUNDRY AND MACHINE COMPANY,

Successors to MERRICK & SONS,

GAS APPARATUS,

Holdings, Purifiers, Washers, Etc., Etc. Boiler and Tank Work. Steam Engines.
Hydraulic Machinery. Bessemer Plants, Etc.

Washington Ave. and Fifth Street, Philadelphia, Pa.

MORRIS, TASKER & CO.,

Limited,

Builders of Gas Works,

PHILADELPHIA PA.

THE KERR MURRAY MANUFACTURING COMPANY,
Fort Wayne, Ind.

CONSTRUCTING ENGINEERS AND BUILDERS OF

GAS WORKS AND HOLDERS.

Drawings, Estimates, and Specifications Furnished for the Construction of New and the
Rebuilding of Old Works.

MANUFACTURERS OF LATEST IMPROVED APPARATUS FOR COMPLETE AND AUXILIARY OIL AND WATER GAS PLANTS.

Rotary and Steam Jet Exhausters, Rotary Washers, Self-Sealing Mouthpieces,

HYDRAULIC LIFTS FOR PURIFIER COVERS.

"VALVE COMBINATION" FOR OPERATING ONE TO FOUR OR MORE PURIFIERS.

Street Specials, Valves, and Fittings.

COKE CRUSHERS, COAL AND COKE WAGONS, LAMP POSTS.

Iron Roofs, Cutters, and Retort House Floors.

STEAM ENGINES AND BOILERS, IRON COAL SHEDS.

Single and Telescopic Gasholders.

Correspondence is Respectfully Solicited.

GAS WORKS APPARATUS AND CONSTRUCTION.

GAS WORKS APPARATUS AND CONSTRUCTION.

JAMES R. FLOYD,

(SUCCESSOR TO HERRING & FLOYD)

Oregon Iron Works,

531 to 543 West 20th St., N. Y.

Practical Builders of Gas Works,

MANUFACTURERS OF

ALL KINDS OF CASTINGS

AND

APPARATUS FOR GAS-WORKS.

BENCH CASTINGS

from benches of one to six Retorts each.

WASHERS: MULTITUBULAR AND AIR CONDENSERS; CONDENSERS; SCRUBBERS

(wet and dry), and

EXHAUSTERS

for relieving Retorts from pressure.

BENDS and BRANCHES

all sizes and description.

FLOYD'S PATENT

MALLEABLE RETORT LID.

PATENT

SELF-SEALING RETORT LIDS.

FARMER'S

PATENT BYE-PASS DIP-PIPE.

SABBATON'S PATENT

FURNACE DOOR AND FRAME.

BUTLER'S

COKE SCREENING SHOVELS.

GAS GOVERNORS,

and everything connected with well regulated Gas Works at low price, and in complete order.

SELLER'S CEMENT

for stopping leaks in Retorts.

N. B.—**STOP VALVES** from three to thirty inches—at very low prices.

Plans, Specifications, and Estimates furnished.

Bouton Foundry Co.,

FOUNDERS AND MACHINISTS,

CHICAGO, ILL.

Gas Works Apparatus,

PURIFIERS, CONDENSERS,

Bench Work,

SPECIALS, LAMP POSTS,

SCRUBBERS,

Iron Roofs and Floors.

Plans and Estimates furnished for new works or extensions of old works.

BOOKS.

DISTILLATION OF COAL TAR AND AMMONIACAL LIQUOR.

By **GEORGE LUNGE.** Price \$8.50.

A TREATISE ON THE COMPARATIVE COMMERCIAL VALUES OF GAS COALS AND CANNELS.

By **DAVID A. GRAHAM.** 8vo., Cloth. Price \$3.

Orders for these books may be sent to this office.

A. M. CALLENDER & CO.,

42 PINE ST., N. Y. CITY.

CONTINENTAL WORKS.



GASHOLDERS OF ANY MAGNITUDE.

T. F. ROWLAND, Proprietor,

GREENPOINT, BROOKLYN, N. Y.

ENGINEER AND MANUFACTURER OF

GAS-HOLDERS.

CONDENSERS, SCRUBBERS, VALVES,

PURIFIERS, RETORTS, and HY-

DR АуLIC MAINS,

and all other articles connected with the Manufacture and Distribution of Gas. Plans and Specifications prepared and Proposals given for the necessary Plant for Lighting Cities, Towns, Mansions, and Manfactories.

H. RANSHAW, Prest. & Mangr. WM. STACEY, Vice-Prest. T. H. BIRCH, Asst. Mangr. R. J. TARVIN, Sec. & Treas.

STACEY MFG. CO.,

MANUFACTURERS OF

Single and Telescopic Gasholders,

IRON ROOFS, BRIDGES, LAMP POSTS,

Water and Oil Tanks, Coal Elevator Cars,

COKE CRUSHERS, BENCH CASTINGS,

And all kinds of Wrought and Cast Iron Work used in the erection of Coal and Oil Gas Works. Rolling Mill Machinery and Heavy Castings a Specialty.

Foundry:

33, 35, 37 & 39 Mill Street.

Wrought Iron Works:

16, 18, 20, 22, 24 & 26 Ramsey Street.

Cincinnati, Ohio.

BARTLETT, HAYWARD & CO.

Office, German & Calvert.

BALTIMORE, MD.

Works, Pratt & Scott.

PURIFIERS.
Roofs.
Bench Castings.

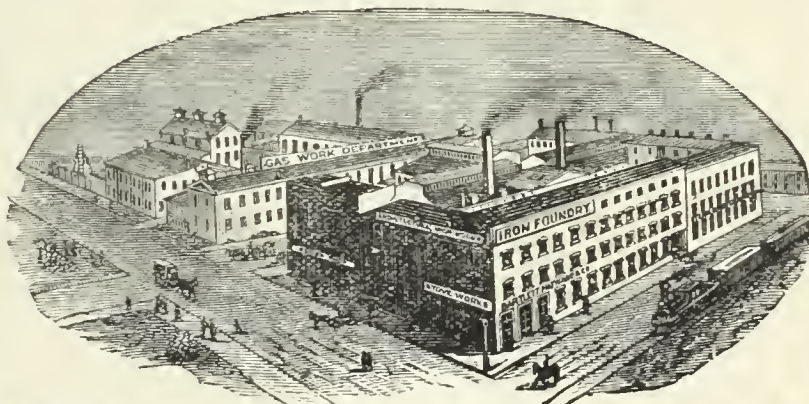

CONDENSERS
BOILERS.
SCRUBBERS.

GASHOLDERS.

CONSTRUCTING ENGINEERS AND BUILDERS OF GAS WORKS.

1842. DEILY & FOWLER, 1887.

Laurel Iron Works.

Address, No. 39 Laurel Street, Philadelphia, Pa.

MANUFACTURERS OF

GASHOLDERS.

Single or Telescopic, with Cast or Wrought Iron Guide Frames.

HOLDERS BUILT SINCE 1881:

- | | | | | |
|-----------------------|----------------------------|---------------------------|----------------------------|----------------------------|
| Scranton, Pa. (2d) | Hollidaysburg, Pa. | Jackson, Mich. | Montgomery, Ala. | New Castle, Pa. |
| West Point, N. Y. | Galveston, Texas (2d.) | Kalamazoo, Mich. (3d.) | Newport, R. I. | Long Island City, N. Y. |
| Fitchburgh, Mass. | Marlboro, Mass. | Glen Island, N. Y. | Portland, Oregon. | Macon, Ga. |
| New London, Conn. | Denver, Col. | Warren, Ohio. | Allegheny, Pa. (2d.) | York, Pa. |
| Derby, Conn. | Chicago, Ill. (West Side). | Bath, N. Y. | Atlanta, Ga. (2d.) | Chester, Pa. |
| Bridgeport, Conn. | Pittsburgh, Pa. (S. Side) | Lynn, Mass. | N.Y. City (Central Gas Co) | Hazleton, Pa. 2d.) |
| Allegheny, Pa. (1st.) | Pawtucket, R. I. | New Bedford, Mass. | Lynchburg, Va. (2d.) | Novelties Exhib. Phila |
| St. Hyacinth, Can. | Brookline, Mass. | Waterbury, Conn. | Saylesville, R. I. | State Island, N. Y. |
| Norwalk, O. | Sherbrooke, Can. | Deseronto, Can. | Rondout, N. Y. | Saugerties, N. Y. |
| Brattleboro, V | Burlington, N. J. (2d.) | Hoosic Falls, N. Y. (2d.) | Atlantic City, N. J. | Clinton, Mass. (Lan. Mills |
| Waltham, Mass. (2d.) | Bridgeton, N. J. | Bethlehem, Pa. | Augusta, Ga. | Chattanooga, Tenn. |
| West Chester, Pa. | Bay City, Mich. | Atlanta, Ga. (1st.) | Waltham, Mass. (2d) | Galveston, Texas. (3d.) |
| Baltimore, Md. | Erie, Pa. | Savannah, Ga. | Mahanoy City, Pa. | Omaha, Neb. |

GAS COALS.

CANNEL COALS.

GAS ENRICHERS.

JAMES D. PERKINS.

PERKINS & CO.,

F. SEAVERNS.

General Sales Agents for

The Youghioghenny River Coal Company's**OCEAN MINE YOUGHIOGHENY GAS COAL.**

The Coal from the Ocean Mine (recently operated by *Messrs. W. L. Scott & Co.*, of Erie, Pa.,) is now used by all the leading Gas Companies in the United States from Maine to Texas, and is recognized as *the only reliable Youghioghenny Gas Coal.* (See Map on p. 87 of this Journal, Feb. 16, '85.)

P. O. Box 3695,
New York.**PERKINS & CO., 228 and 229 N. Y. Produce Exchange.**BEAVER STREET
ENTRANCE.**BRECKENRIDGE CANNEL,
OF KENTUCKY.**

This Colliery was re-opened in June, 1886, since which date the Cannel has been delivered to over sixty of the leading Gas Companies in this country and in Europe. As an enricher ONE TON of this Cannel will do the work of two TONS of any other available Cannel, and is more economical than Naptha or Oil of any character. It can be delivered in parcels of one car load or more to any point in the United States or Canada.

(See AMERICAN GAS LIGHT JOURNAL, June 16, '86, pp. 346-7.)

P. O. Box 3695,
New York.**PERKINS & CO., 228 and 229 N. Y. Produce Exchange**BEAVER STREET
ENTRANCE.**JAMES & WILLIAM WOOD,****Gas and Cannel Coal Contractors,**

No. 40 St. Enoch Sq., Glasgow. No. 2 Talbot Court, London.

Proprietors of the **BATHVILLE COLLIERIES** (which produce the celebrated **BOGHEAD CANNEL**), Shields, Shieldmuir, Drumpeller, and other Collieries. This Firm offer

STANDARD CANNELS,**Unequaled as Gas Enrichers.**

Analyses, prices, and all further information furnished on application to

Agency for U. S., Room 93, Nos. 2 & 4 Stone St., N. Y. City.**The Standard Oil Company,**

REFINERS OF

NAPTHA AND GASOLINES.

ALSO MANUFACTURERS OF

**A Special Grade of Naptha for
Gas Companies****FOR ENRICHING COAL GAS.**

Correspondence solicited.

No. 43 Euclid Avenue, Cleveland, Ohio.

To Gas Companies.We make to order **CAP BURNERS** to burn any amount under a stated pressure. Send for samples.Also, **SERVICE CLEANERS, DRIP PUMPS,** and **STREET MAIN PROVING APPARATUS.****C. A. GEFROER,**

248 N. 8th Street, Phila., Pa.

GOODWIN'S DIRECTORY**OF THE GAS LIGHT COMPANIES of the UNITED STATES & CANADA.**Price, **\$10.00.**

Orders may be sent to

A. M. CALLENDER & CO., No. 42 Pine Street, N. Y. City.

COKE CRUSHERS.

GAS COALS.

GAS COALS.

Newburgh Orrel Coal Co.,

MINERS AND SHIPPERS OF

Mountain Brook Steam and Smithing Coals,

AURORA, TYRCONNELL & PALATINE GAS COALS.

Foundry & Crushed Coke Shipped Direct from Ovens

Mines Situated at

Newburgh, Flemington & Fairmont, W. Va.

HOME OFFICE,

33 S. Gay St., Baltimore.

CHAS. MACKALL, Gen. Mangr.

CHAS. W. HAYS, Agent in New York,

Room 147, WASHINGTON BUILDING, No. 1 Broadway.

Shipping wharves at Locust Point, Baltimore.

THE DESPARD COAL COMPANY

OFFER THEIR SUPERIOR

DESPARD COAL

To Gas Light Companies and Manufacturers of Fire Clay Goods Throughout the Country.

ROUSSEL & HICKS, } AGENTS. { BANGS & HORTON, }
71 Broadway, N. Y. } { 16 Kilby St., Boston. }

Mines in Harrison Co., West Va. Wharves, Locust Point, Balt.

Company's Office, 15 German St., Baltimore, Md.

Among the consumers of Despard Coal we name: Manhattan Gas Light Co., N. Y.; Metropolitan Gas Light Co., N. Y.; Jersey City, (N. J.) Gas Light Co.; Washington (D. C.) Gas Light Co.; Portland (Maine) Gas Light Co. Reference to them is requested.

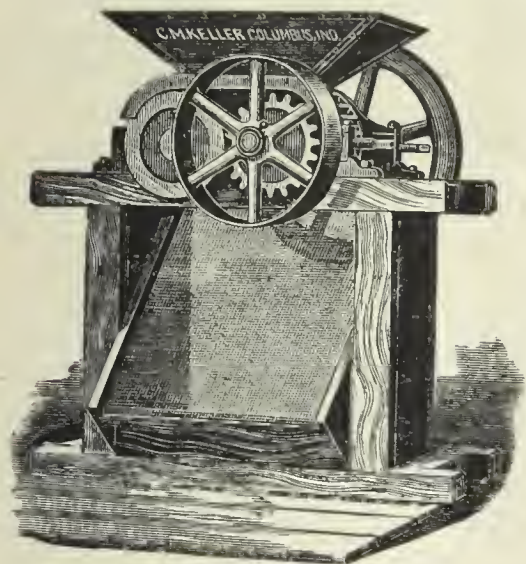

Keller's Adjustable Coke Crusher.

SIMPLE, STRONG, AND DURABLE.

C. M. Keller, Sec. & Supt. Gas Lt. & Coke Co. Columbus, Ind.

Correspondence Solicited.

GAS COMPANIES, ATTENTION!

Increase the demand for Coke by using the

Star Coke Breaker.

SIMPLE, CHEAP, DURABLE. EASILY SHARPENED BY ANY BLACKSMITH.

B. J. ALLEN, Newark Gas Co., Newark, N. J.

King's Treatise on Coal Gas.

The most complete work on Coal Gas ever published.

Three Vols. Bound, \$30.

A. M. CALLENDER & CO., 42 Pine St., N. Y.

THE PENN GAS COAL CO.

OFFER THEIR

Coal, Carefully Screened & Prepared for Gas Purposes.

Their Property is located in the Youghioghny Coal Basin, near Irwin and Penn Stations on the Pennsylvania Railroad, and on the Youghioghny River.

Principal Office:

209 SOUTH THIRD STREET, PHILA., PA.

Points of Shipment:

Pennsylvania Railroad Piers; Greenwich Wharves, Delaware River; Pier No. 1 (Lower Side), South Amboy, N. J.

Chesapeake & Ohio Railway Coal Agency,

FOR THE SALE OF THE

Superior Kanawha Gas Coals, Cannelton Cannel, Also, SPLINT AND STEAM COALS,

From the Kanawha and New River Regions, on the line of the Chesapeake & Ohio R'way.

C. B. ORCUTT, Sales Agent. | OFFICE, 150 BROADWAY, N. Y.

FRANCIS H. JACKSON, Prest. EDMUND H. MCCULLOUGH, V.-Prest. CHAS. F. GODSHALL, Treas. H. C. ADAMS, Sec.

THE WESTMORELAND COAL CO.

Chartered 1854.

Mines situated on the Pennsylvania and the Baltimore and Ohio Railroads, in Westmoreland County, Penn.

POINTS OF SHIPMENT:

PHILADELPHIA, BALTIMORE, SOUTH AMBOY, N. J., WATKINS (SENECA LAKE), N. Y.

Since the commencement of operations by this Company its well-known Coal has been largely used by the Gas Companies of New England and the Middle States, and its character is established as having no superior in gas giving qualities, and in freedom from sulphur and other impurities.

Principal Office, 224 South 3d St., Phila., Pa.

A. M. SCOTT, PRESIDENT. A. DEMPSTER, C.E., SECRETARY. W. K. GILLESPIE, TREASURER.

MONONGAHELA AND PETERS CREEK GAS COAL CO.,

PRODUCERS OF

Coal Bluff Gas Coal.

MINES LOCATED ON THE MONONGAHELA DIVISION OF THE PENNSYLVANIA RR., IN THE CENTRAL PORTION OF THE PITTSBURGH COAL FIELD.

Points of Shipment—Buffalo, Cleveland, Erie, Chicago, New Orleans.

Since the introduction of Coal Bluff Gas Coal it has taken rank among the few first-class Gas Coals, and acknowledges no superior in gas-giving qualities, ease of working, quality of coke, and freedom from impurities.

Milwaukee Agents, F. R. BUELL & CO., - - - Milwaukee, Wis.

General Office, 43 Sixth Ave., Pittsburgh, Pa.

GAS METERS.

GAS METERS.

GAS METERS.



INTERNATIONAL--1876--EXHIBITION.

The U. S. Centennial Commission

HAVE DECREED AN AWARD TO

HARRIS, GRIFFIN & CO.,



Twelfth and Brown Streets, Philadelphia, Pa. No. 49 Dey Street, N. Y. City, and No. 75 North Clinton Street, Chicago, Ill.

FOR THE FOLLOWING REASONS :

The Exhibit consists of a Series of METERS from the Largest Size Station Meters for the use of the MANUFACTURE OF GAS, to those for the use of the ORDINARY CONSUMER. The Instruments are WELL MADE, RELIABLE as to INDICATION, and embody a number of sundry improvements which, with the general character of the Exhibit, entitle the whole to commendation.

Attest—J. L. CAMPBELL,
Secretary, pro-tem.

Signed—A. T. GOSHORN,
Director General

J. R. HAWLEY,
President

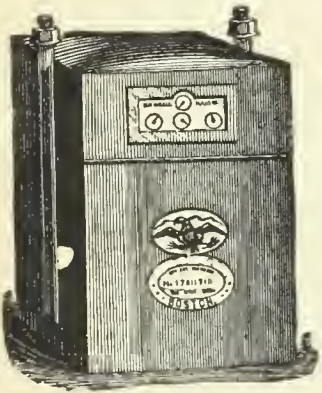

Dry Gas Meter.

With 39 years' experience and the best facilities for manufacturing, is enabled to furnish reliable work and answer orders promptly.

NATHANIEL TUFTS,

No. 153 Franklin Street, Boston, Mass.,

MANUFACTURER OF

DRY GAS METERS.

Station Meters of any Capacity.

Test and Experimental Meters, Pressure Registers, Pressure Gauges,
Pressure and Vacuum Gauges.

METER PROVERS, PHOTOMETERS, STREET LANTERNS, ETC., ETC.

Patent Cluster Lanterns for Street Illumination.

SCIENTIFIC BOOKS.

We are prepared to furnish to Gas Managers, and others interested in the topics treated of, the following books, at prices named :

KING'S TREATISE ON THE MANUFACTURE OF COAL GAS. Three vols.; \$10 per vol.	PRACTICAL TREATISE ON HEAT, by THOMAS BOX. Second edition. \$5.	THE GAS MANAGER IN THE LABORATORY, by a Practical Student. 8vo., Cloth. \$1.50.
GAS MANUFACTURE, by WILLIAM RICHARDS. 4to., with numerous Engravings and Plates, in Cloth binding. \$12.	GAS WORKS—THEIR ARRANGEMENT, CONSTRUCTION, PLANT, AND MACHINERY. \$8.	THE DOMESTIC USES OF COAL GAS, AS APPLIED TO LIGHTING, by W. SUGG. \$1.40.
THE GAS ANALYST'S MANUAL, by F. W. HARTLEY. \$2.50.	COAL; ITS HISTORY AND USE, by PROF. THORPE. \$3.50.	DISTILLATION OF COAL TAR AND AMMONIACAL LIQUOR by GEO. LUNGE. \$8.50.
TECHNICAL GAS ANALYSIS. \$2.80.	THE GAS WORKS OF LONDON, by COLBURN. 60 cents.	A TREATISE ON THE COMPARATIVE COMMERCIAL VALUES OF GAS COALS AND CANNELS, by D. A. GRAHAM 8vo., Cloth. \$3.
GAS MANAGER'S HANDBOOK, by THOS. NEWBIGGING. \$4.80.	THE GAS FITTER'S GUIDE, Showing the Principles and Practice of Lighting with Coal Gas, by JOHN ELDREDGE. 40 cents.	GAS AS A SOURCE OF LIGHT, HEAT, AND POWER, by C. J. R. HUMPHREYS. 10 cents.
GAS CONSUMER'S GUIDE. \$1.	GAS WORKS, AND MANUFACTURING COAL GAS, HUGHES. \$2.20.	GAS COMPANIES DIRECTORY. \$10.
A GUIDE TO GAS LIGHTING. 40 cents.	THE MANAGEMENT OF SMALL GAS WORKS, by C. J. R. HUMPHREYS. \$1.	GAS VERSUS ELECTRIC LIGHT. 50 cents.
GAS MEASUREMENT AND GAS METER TESTING, by F. W. HARTLEY. \$1.60	MANUAL FOR GAS ENGINEERING STUDENTS, by D. LEE, 40 cents.	PURIFICATION OF COAL GAS, by R. P. SPICE. 8vo. \$3.
GAS CONSUMER'S HANDBOOK, by WILLIAM RICHARDS, C.E.; 18mo., Sewed. 20 cents.	HOW TO MANAGE GAS, by F. WILKINS. Paper. 20 cents.	
A PRACTICAL TREATISE ON GAS AND VENTILATION with Special Relation to Illuminating, Heating, and Cooking by Gas, by E. E. PERKINS. \$1.25.		

The above will be forwarded by express, upon receipt of price. We take especial pains in securing and forwarding any other Works that may be desired, upon receipt of order. All remittances should be made by check, draft, or post office money order.

A. M. CALLENDER & CO., No. 42 Pine Street, New York.

KING'S TREATISE ON COAL GAS.

The most complete work on Coal Gas ever published. Three vols., bound \$30.

A. M. CALLENDER & CO., No. 42 Pine Street, New York.

GAS METERS.

GAS METERS.

GAS METERS.

GEO. J. McGOURKEY, Pres.

WM. H. McFADDEN, Vice-Pres. (Phila.).

WM. N. MILSTED, Gen. Supt. & Treas. (New York).

WM. H. DOWN Sec.

AMERICAN METER COMPANY,

WET AND DRY GAS METERS.

PRESSURE REGISTERS.

METER PROVERS.

STATION METERS.

PRESSURE & VACUUM REGISTERS.

PORTABLE TEST METERS.

EXHAUSTER GOVERNORS.

PRESSURE & VACUUM GAUGES.

EXPERIMENTAL METERS.

DRY CENTRE VALVES.

CRESSON GAS REGULATORS.

AMMONIA TEST METERS.

GOVERNORS FOR GAS WORKS.

MARSLAND WATER METERS.

BAR AND JET PHOTOMETERS.

Manufactories:

512 W. 22d St., N. Y.
Arch & 22d Sts., Phila.

GAS STOVES,

SUGG'S "STANDARD" ARGAND BURNERS,
SUGG'S ILLUMINATING POWER METER,
Wet Meters, with Lizar's "Invariable Measuring" Drum.

Agencies:

177 Elm Street, Cincinnati.
244 & 246 N. Wells Street, Chicago.
810 North Second Street, St. Louis.
122 & 124 Sutter St., San Francisco.

HELME & McILHENNY,

(Successors to Harris & Brother. Established 1848.)

GAS METER MANUFACTURERS,

CONTINUE AS HERETOFORE AT THE OLD ESTABLISHMENT,

Nos. 1339 to 1349 Cherry Street, Philadelphia, Pa.,

To Manufacture Wet and Dry Gas Meters, Station Meters, Experimental Meters, Meter Provers, Center Seals, Pressure Registers

GOVERNORS, INDICATORS, PHOTOMETERS, & ALL OTHER KINDS OF APPARATUS FOR USE IN GAS WORKS.

From our long practical experience of the business, and from our personal supervision of all work, we can guarantee all orders to be executed promptly and in every respect satisfactorily.

WM. WALLACE GOODWIN, Pres. and Treas.

WM. H. MERRICK, V.-Pres.

S. L. JONES, Sec.

S. V. MERRICK, Supt.

THE GOODWIN GAS STOVE AND METER COMPANY,

Successors to W. W. GOODWIN & CO.

1012, 1014 and 1016 Filbert St., Phila., Pa. 142 Chambers St., New York.
76 Dearborn St., Chicago, Ill.

WALDO BROS., Agents, 88 Water St., Boston.

MANUFACTURERS OF THE "SUN DIAL" GAS STOVES, FOR COOKING AND HEATING PURPOSES.

Dry and Wet GAS METERS, Station Meters (Square, Cylindrical or in Staves) Glazed Meters, King's and Sugg's Experimental Met Lamp Post Meters, Etc., Etc., Meter Provers (sizes 2, 5 and 10 feet), Pressure Guages of all kinds, Pressure Registers, Pressure and Vacuum Registers, Pressure Indicators (sizes 4 inch, 6 inch and 9 inch), King's Pressure and Vacuum Gauges, Dry and Wet Centre Seals, Dry and Wet Governors, Exhauster Governors, Photometers of all descriptions. Lethby's Sulphur and Ammonia Test Apparatus complete—also Testing and Chemical Apparatus of all kinds, and of the most perfect description, for all purposes relating to Gas.

GOODWIN'S IMPROVED LOWE'S JET PHOTOMETER.

Agents for Bray's Patent Gas Burners and Lanterns.

Special attention to repairs of Meters, and all apparatus connected with the business.
All work guaranteed first class in every particular, and orders filled promptly.

G. B. EDWARDS, Mang'r, New York.
E. H. B. TWINING, Mang'r, Chicago.
Represented by A. B. STANNARD.

D. McDONALD & CO.,

GAS METER MANUFACTURERS.

(Established 1854.)

51 Lancaster St., Albany, N. Y. 34 & 36 West Monroe St., Chicago, Ill.

STATION METERS, EXPERIMENTAL METERS, METER PROVERS, PRESSURE & VACUUM REGISTERS, PRESSURE GAUGES, ETC.

Also STAR GAS STOVES, RANGES, and HEATING STOVES.

We use only the very best materials, and employ the most skilled labor, and by our long experience (32 years) and personal supervision of every detail, we feel justified in assuring the public that our goods will give perfect satisfaction. Every Meter emanating from our establishment will bear the State Inspector's ~~Label~~, and will be fully warranted by us. Our Annual and Calendar will be sent to Gas Companies upon application.

GAS ENGINES.

GAS ENGINES.

GAS ENGINES.

THE "OTTO" GAS ENGINE.

Guaranteed to Consume 25 to 75
Per Cent. LESS GAS than ANY OTHER GAS ENGINE
DOING THE SAME WORK.

TWIN ENGINES Impulse every revolution.
THE STEADIEST RUNNING GAS ENGINE YET MADE.

ENGINES AND PUMPS COMBINED,

For Hydraulic Elevators, Town Water Supply, or Railway Service.

Special Engines for Electric Light Work.

OVER 15,000
IN USE.

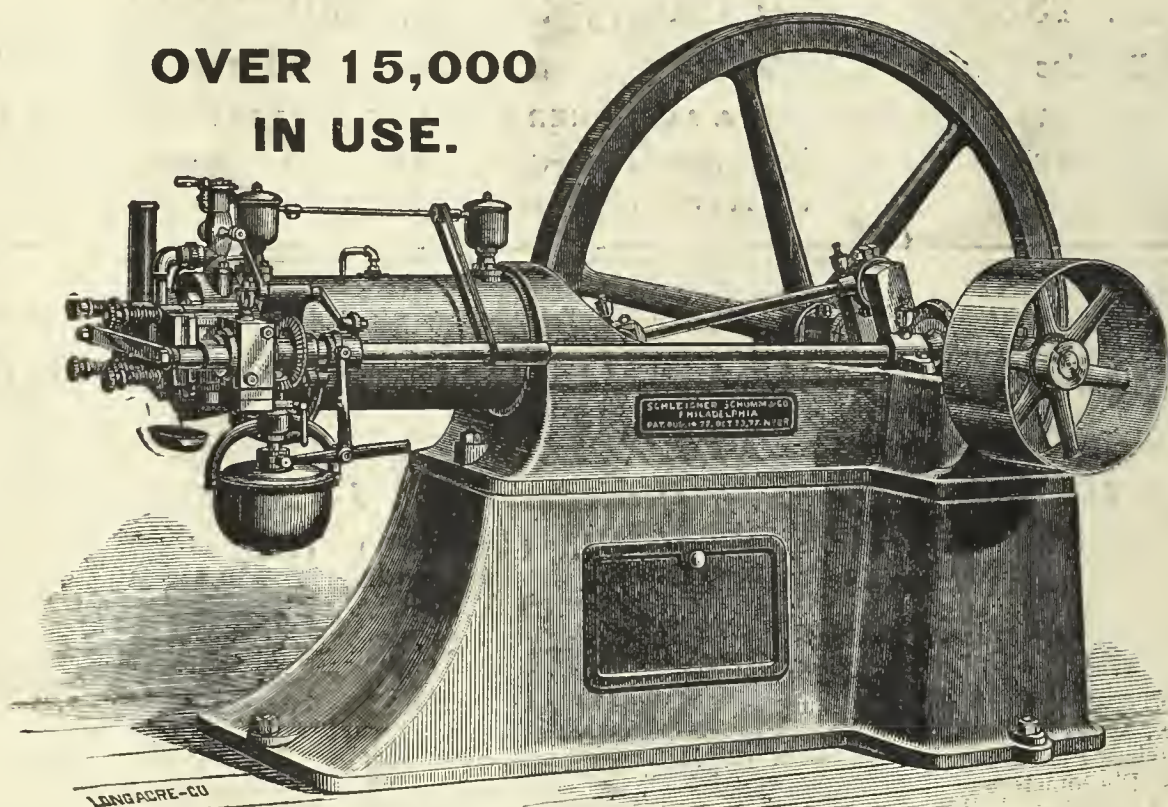

The Otto Gas Engine is now consuming, at a moderate computation, 2000 millions cubic feet of gas per year, nearly all of which is furnished during day time only.

**THE ONLY HIGHEST AWARD, ONLY GOLD MEDAL,
AT ELECTRICAL EXHIBITION, PARIS, 1881.**

MADE IN SIZES FROM 1 TO 25 HP. INDICATED.

FOR PARTICULARS, PRICES, ETC., APPLY TO

SCHLEICHER, SCHUMM & CO.,

Works:

Branch Office:

N. E. Cor. 33d & Walnut Sts., Phila., Pa.

130 Washington Street, Chicago, Ill.

THE AMERICAN

GAS LIGHT JOURNAL

REDMAN & KENNY, N. Y.

PUBLISHING OFFICE No. 42 PINE STREET

DEVOTED TO THE INTERESTS OF ILLUMINATION, VENTILATION, WATER SUPPLY AND DISTRIBUTION, & GENERAL SCIENCE.

VOLUME XLVI.—No. 11. }
Whole No. 671.

NEW YORK, THURSDAY, JUNE 2, 1887.

{ \$3 PER ANNUM,
IN ADVANCE.

A. M. CALLENDER & CO., Proprietors. C. E. SANDERSON, Manager.
JOS. R. THOMAS, C.E., Editor. T. J. CUNNINGHAM, Asst. Editor.

ENTERED AT THE POST OFFICE AT NEW YORK, N. Y.
AS SECOND CLASS MATTER.

Published on the 2d and 16th of each month, at No. 42 Pine Street, N. Y.

Terms of Subscription, Including Postage.—For the United States and Canada, \$3 per annum. European countries, \$3.50 (15 shillings—18 francs). All payments to be made in advance. Single copies, 15 cents.

Remittances should be made either by post-office order, registered letter, or bank draft on New York, payable to the order of A. M. Callender & Co.

Correspondence.—Wishing to make this JOURNAL a gazette of intelligent discussion to those of our readers who may wish to gain or give information on the subjects to which its columns are devoted, correspondence is solicited for publication from all who make the study of those subjects a pleasure or a profession.

The American News Company, Nos. 39 and 41 Chambers street, New York, are agents for this JOURNAL. Newsdealers will send orders to them.

Collections are invariably made directly from this office, for subscriptions, advertisements, etc. We have agents to solicit the same, but they are not authorized to receipt for money.

Books.—We will forward by express, at publisher's lowest rates, any book—scientific or otherwise—to any address in the United States or Canada. No books will be sent C. O. D.

CONTENTS.

An Asterisk (*) denotes an illustrated article.

EDITORIALS—

The Western Association's Tin Wedding..... 341

The First Verdict Rendered by the Massachusetts Gas Commission..... 342

Tenth Annual Meeting of the Western Gas Association—Official Report..... 343

First Day, Morning Session—Roll Call—President's Address—Committee on President's Address—Introducing the Visitors—Some Communications—Letters of Regret, etc.—Reading the Papers—An American Gas Institute, by Frederic Egner—Discussion.

New Process for the Protection of Iron..... 348

Has the Length of the Photometer Bar any influence in Determining the Results of the Observations, by D. Coglievina, C.E. 348

Special English Correspondence..... 349

Another Steam Roller Case—Gas for the People—A Reckless Corporation—Another Suggestion as to Selling Sulphate—Natural Gas in England—New Applications for Coal Tar.

Siberian Exhibition..... 350

ITEMS OF INTEREST FROM VARIOUS LOCALITIES..... 351

Denver (Col.) Gas Men at Work—Duluth (Minn.) also in Line—Changes at Detroit, Mich.—Annual Election, Glens Falls, N. Y.—Worcester (Mass.) Items—Personal—An Echo from Grand Rapids, Mich.—Death of Mr. Lewis—Some Orders in Hand for the Church Tray—Gas Coal for the Quaker City Works—Change in the Massachusetts Gas Commission—Birds of Passage—Something More about Grand Rapids, Mich.—Agency for the Breckenridge Cannel—The Arkansas City (Ark.) Gas Plant—We Might as Well Finish it—Annual Election, East Albany, N. Y.—As Viewed by a Macon (Ga.) Newsman—Holyoke (Mass.) to Have Cheaper Gas—Consolidated Company (N. Y.) Extensions—Annual Meeting, Portland (Me.) Gas Light Company—An English Holder for the Toronto (Can.) Works—An Important Legal Definition—Another Horror at the Mankato (Minn.) Gas Works—Erratic Incandescent Lamps—The Contract Awarded—Sold—Tyler, Texas—Busy Manufacturers—Buying Out the Utica (N. Y.) Company—New Works—Election of Directors, Mutual (N. Y.) Company—Annual Election, Montclair (N. J.) Gas and Water Company—The Gate City Company—Good News—A Line from Lawrence, Mass.—Down again at North Adams, Mass.—Made Inspector—Northampton (Mass.) Gas Doings—The Sanford (Fla.) Folks again at Work—New Company.

The Market for Gas Securities..... 354

THE WESTERN ASSOCIATION'S TIN WEDDING.

Having attended the above named tin wedding, we suppose it is only proper that we should report upon the looks of the matron, and we hereupon say that she is bonnie, blithesome and bouncing; in fact that the lapse of years has but added to her attractions. The Eastern section of the visitors expected to be able to render this verdict, but were hardly prepared to be ushered into the ante-room, as it were, of the matron's household (located for the tin wedding occasion in St. Louis, Mo.) with such a grand accompaniment of lightning, thunder and rain. However, the Hartford gas oak (Jno. P., of course) decided that it should be accepted in proper spirit, and merely as a just tribute to the greatness of those who had traveled so far to pay their homage to the bride of a decade ago. Humphreys, more sedate, suggested that it might be a warning to those Easternites who had been coquetting with certain electric light suppliers, but had not yet bound the bargain, to complete the negotiations forthwith. Notwithstanding this difference of opinion no blows were struck, albeit some of the party managed to make very good time between the depot and the Southern Hotel. The headquarters already held a goodly delegation, and newcomers were constantly putting in an appearance. Shortly after 10 o'clock of the following day the visitors sought the hall of the Elks' Club, and when, in due time, President Fullagar called for order he had the pleasure of facing a royally good attendance, and Secretary Littleton, from his clerical position, smiled—he might as well have said, in so many words loudly spoken, "Didn't I tell you so?" Nevertheless, there was to be a drop of bitterness in the attendance eup, after all. It had been sadly and sorrowfully known that the chair so often occupied by the honored founder of the Association—the late Mr. J. O. King, of Jacksonville, Ills.—would be vacant, and forever so in the future gatherings of the body that he had so carefully fostered. But if dead to this life, he vigorously lives in the hearts and thoughts of those who now tread onwards to the heritage awaiting them. First the query was, "Where is Somerville?" Then rapidly came inquiry for Prof. Douglas, Ramsdell, Hyde, Sr., Butterworth, Bushnell, and others who were wont to gather for the fray. But time presses, and before we have realized it the tin wedding routine is fairly underway. The roll call published in our first installment of the official report will show that, even if some of the war horses were absent, many had responded to the call of duty, and further on the same pages will reveal the fact that others had journeyed from afar to commune with their fellows in mental and social siege. Denniston, of Pittsburgh, Pa.; Leach, of Taunton, Mass.; Humphreys, of Lawrence, Mass.; Sherman, of New Haven, Conn.; and Capt. White, of New York—in regard to the latter many regretted that he failed to bring on his army mule, but was forgiven when he (the Cap.) explained that the "mule" had been accidentally killed in Cincinnati, shortly after the conclusion of the recent banquet in that city to its members and guests by the Ohio Commandery Military Order of the Loyal Legion. Some surprise was excited by the fact that Associate Member J. J. Griffin, of the Quaker City, seemed to have reached that stage in his career where the services and influence of a minister of the Gospel were needed to keep him in the way that is straight, although rugged and narrow is the path thereto and thereof. President Fullagar's address beyond doubt possesses that merit which is supposed to comprise

the soul of wit, but he nevertheless managed to touch upon those questions that appeal most forcibly to the gas maker of to-day. Some of his hints are well worth thinking over, particularly those in regard to the "rounding up" of ideas, to the end that all may enlarge the dimensions of the corral which contains their information fund. Our impressions in respect of the exceeding great value to be gained by membership in gas associations have been so often asserted that we opine that all will take for granted we are firm believers in their efficacy and worth as agents for the distillation and dissemination of useful gaseous information. President Fullagar evidently does not fear greatly either electric light or natural gas; and we presume that if every gas engineer could count readily and surely upon the tactical services of a Hickenlooper, why, all would say, "Amen!" The trouble is, men of that caliber are not in great profusion, more's the pity, too. Electric light certainly presents a pretty strong front just now, and a prudent soldier always provides an avenue of escape—open at both ends, if possible, but never hermetically sealed in the rear. Two items in the President's address seem to be somewhat conflicting. He refers to the great saving in labor that can be effected (in works of a certain capacity) by the use of stoking machines—in fact instances something like a saving of 20 per cent. accruing from them in the operation of drawing by their aid. No doubt that is so; but if in their present crude (so-to-speak) condition stoking machines have developed that advance, inventors ought surely to be able to so perfect them as to perhaps quadruple their efficiency. The principle being there the practice ought to speedily outstrip the original idea. But turning aside from that, Mr. Fullagar suddenly suggests that "in all large plants water gas, in connection with coal gas, is very desirable, for two excellent reasons. First, as an enricher; secondly, as an instrument of moral suasion to be used upon workmen in allopathic doses." Leaving aside the fact that we know of several large plants to-day under the control of men thoroughly abreast of the times in the principle and practice of their profession, in which it is unlikely that water gas (at least in its present developmental stage) will ever be manufactured, simply because the manufacture and sale of coal gas is the more profitable course to pursue, we fail decidedly to note the advantage to be gained in distributing a water-gas-enriched coal gas. Least of all do we discern the advantage if you care anything for the wishes of your consumers. No; it must be either coal gas or water gas—the two cannot be satisfactorily wedded. And if President Fullagar wishes to hold his workmen in check let him keep on developing the opportunities presented in mechanical stoking. Another thing that has been aired somewhat extensively of late is the contumely to which those *engineers* and *superintendents* who spoke favorably of water gas were subjected in the past. Those who make such assertions seem to us to be wide of the mark; and perhaps we are qualified to speak thereon, since we caught an occasional glimpse of the battle. Those who sought by piratical practices to foist their "systems" on the owners of plants who refused to purchase the "patent rights" of the despoilers were the parties contemned, and whose wretched rapacity ought not to be condoned. If these things are to be publicly alluded to they should be mentioned as they were. Water gas engineers, in their province as members of the craft, have never been assailed. Some of their employers were, and richly the latter deserved everything that was said of them.

Secretary Littleton, it may be remembered, was at one time somewhat dubious in respect of the threatened paucity of papers; but a fairly good return was made. Papers were read on "An American Gas Institute," by F. Egner; "Improved Gas Burners," by T. A. Cosgrove; "Distillation of Coal," by J. Gimper; "The Rule of Inverse Squares," by B. E. Chollar; "Furnishing Gas without a Holder," by J. W. Dunbar; and two informal communications—one entitled, "Jottings from Rome, Italy," by E. Schinrock; the other being "A Fraternal Letter," from R. Spencer—were received. In connection with the future presentation of papers to the Western Association, a resolution intended to comport with the present practice of the American and Ohio Associations was passed which authorizes a special committee—to consist of the President, Vice-Presidents and Secretary—to designate subjects for particular members to descant upon. The paper that—and properly, too—received the greatest measure of attention was the one by Mr. Egner. In his usual lucid and entertaining style he placed the subject matter of his theme before the audience, and we sincerely hope that the special committee now in charge of the Egner proposition will report (next year in Chicago) that the foundation stone has been safely laid. The project is a huge one, but its possibilities are simply grand. One of the features of the gathering was the excellent work done by the special committees. Particularly do we ask that one of two of the recommendations in the Committee on President's Address be carefully studied. Our official report will, however, contain an account of all the technical and routine business trans-

sacted at the convention, and we here take leave of that portion of the subject with the remark that Littleton's early fears were groundless.

It is a long time since the banquet table at the Southern was so spread and swept—which operations were conducted, one in elegance and profusion, the other with surprising cleanness—only one shadow obtruding its gloom over the—if we may hint at it—later hours. This was a partial sorrow that the Captain's mule had laid down its life at Cincinnati; for had the mule been quartered in the Southern Hotel stables, some of those behind the draperies would undoubtedly have directed it (the mule) to the rear, perhaps to the front, of a gentleman from the Quaker City unattended by a clerical chaperone. The banquet was a success—beautiful in arrangement, and heartily enjoyed.

The third day was "one continual round of pleasure." During the time of being spreadeagled up and down the noble bosom of the Father of Waters (between the Laclede gas works and the Western Steel Company's plant), the land trip in carriages to the magnificent grounds and buildings of the Jockey Club, where a—lunch, the Committee called it—superb course dinner was served, until the conveyances once again landed their passengers at the Southern's steps, the sightseers experienced nothing but enjoyment, which also enabled them to form some idea of the weight of the labor of love that had been carried on the shoulders of the local Committee of Arrangements. Messrs. Green, Thompson and Russell quite likely bore the brunt of the burden; but if appreciation of their efforts is to be reckoned as the price of success, the smiling countenances—likewise the appetites—of those whom they entertained in so royal a manner were everywhere to be seen. Therefore, be it resolved, That the tin wedding was all that any matron might wish for.

THE FIRST VERDICT RENDERED BY THE MASSACHUSETTS GAS COMMISSION.

We believe that one of the leading arguments advanced by the opponents of a Gas Commission for the State of Massachusetts was that the Commissioners would likely be in danger of finding out how great was the weight of idle time when the hours hung heavily from their hands. Perhaps that might safely be regarded as, at worst or best, merely an innocuous objection, since such a state of affairs would pretty conclusively show that Massachusetts gas affairs had been conducted in accordance with fair if not liberal business policy. Be that as it may, we hardly think the former plea would be offered now in opposition, for the Commissioners have been obliged to support the burden of duty on the tops of their palms instead of allowing it to depend from the tips of their fingers—in the nature of a dead weight.

Several allusions have been made in our columns to the hearing that had taken place before the Commissioners, when sitting in Worcester as a quasi-court to determine the merits of the case submitted by some of that city's gas consumers against the local gas company. The Commissioners began the hearing on Feb. 12, sitting at weekly intervals of two or three day sessions, the testimony and arguments being all in on date of March 19. The testimony, aside from certain irrelevant features, was of an interesting character; in fact, at times, varied betwixt the pitch of solid fact and the most nonsensical bombast. The judges, however, took the papers, and after something like nine weeks of sifting and comparison handed down their decision on Saturday, May 14. The report, which is quite lengthy, goes to the marrow of the case, and, if there ever were any reason to believe that the Commission would slight its office, the fairness of the first presentment must go a long way towards putting at rest even the ghost of such suspicion. The Worcester Company entered court with a not over good case. The burden of the complaint was that an adequate supply of gas could not be obtained from the Company, the secondary objection being a paucity of illuminating power in the quantity that was obtainable, a third cause of demur being grounded on an alleged excessive sales rate. The middle objection was easily disproved, and the last was fairly open to debate. In regard to the first objection, however, the complainant's case was almost impregnable. The Worcester Company's district is quite compact, but presents some wavy ridges of territory so baneful to the gas engineer in his distribution policy; nevertheless an inspection of the following statistics will, we submit, go to prove that the proprietors of the Company were amiss in their management of distribution facilities. In 1886 the total accounted-for sendout aggregated, in round numbers, 81,809,000 cubic feet, which was passed through a main system, including pipes of all diameters, whose total length is returned at 29½ miles, and the consumers averaged out at 110.9 to the mile of main. An analysis of the diameter and length of the respective main sizes in use reveals the following:

One inch, 11,688 ft.; 1½ in., 1,366 ft.; 1¾ in., 3,458 ft.; 2 in., 3,892 ft.; 3 in., 73,795 ft.; 4 in., 43,699 ft.; 6 in., 4,085 ft.; 8 in., 6,420 ft.; 10 in., 536 ft.; 16 in., 3,881 ft.

The Commission very properly recommends that this state of affairs be remedied, and the Company acquiesces in the suggestion, as also in agreeing to fix the rate for gas at the figure suggested by the Commission, the reduction being noted in our item columns. There are many timely hints contained in the report, and we are glad to note that the examiners do justice to Brother Rollins, for they say they are "convinced that the manufacture of gas is under the charge of an efficient and competent gas engineer," thus placing the blame for inertness or indifference to the credit of those who ought to bear the weight. The inevitable conclusion in the Worcester case is that the Commissioners have performed their whole duty in the premises with equable exactness.

[OFFICIAL REPORT.]

Tenth Annual Meeting of the Western Gas Association.

HELD AT ST. LOUIS, MO., MAY 11, 12 AND 13, 1887.

FIRST DAY—MORNING SESSION—MAY 11.

The members of the Western Gas Association, convened in Tenth Annual Session, assembled in force at the lodge room of the Elks' Club (corner Sixth and Walnut streets, St. Louis, Mo.), on the hour appointed for the formal opening—10 A.M., Wednesday, May 11. President Fullagar called the Association to order, and Secretary Littleton occupied the recorder's chair.

ROLL CALL.

The following delegates responded to their names :

Honorary Members.

Harbison, J. P., Hartford, Conn. Thomas, Jos. R., New York.

Active Members.

Ambrose, J. S., Springfield, Mo.	Kennedy, J. M., Rockford, Ill.
Averill, A. T., Cedar Rapids, Ia.	King, E. J., Jacksonville, Ill.
Barret, A. H., Louisville, Ky.	Knight, C. S., Fort Wayne, Ind.
Baxter, I. C., Evansville, Ind.	Lansden, T. G., Washington, D. C.
Bixby, W. A., Galena, Ills.	Lindsley, E., Cleveland, O.
Chollar, B. E., Topeka, Kan.	Littleton, A. W., Quincy, Ill.
Clarke, H. E., Kansas City, Mo.	McMillin, E., Columbus, Ohio.
Cosgrove, T. A., Evanston, Ill.	Montgomery, James, Sedalia, Mo.
Coverdale, R. T., Cincinnati, O.	Murdock, Geo. T., Elkhart, Ind.
Cowdery, E. G., Milwaukee, Wis.	Murphy, J. M., Chicago, Ills.
Critchlow, J. M., Beaver Falls, Pa.	Odiome, W. H., Springfield, Ill.
Davidson, J. M., Marshall, Mo.	Page, Geo. S., New York, N. Y.
Davis, D., Iowa City, Ia.	Pratt, Henry, Chicago, Ills.
Dickey, R. B., Lexington, Mo.	Schuster, Paul F., Rockford, Ills.
Egner, F., St. Louis, Mo.	Seofield, L. K., Fort Scott, Kan.
Elbert, V. L., Minneapolis, Minn.	Shreve, C. D., Marshalltown, Ia.
Fullagar, John, Cincinnati, O.	Smedberg, J. R., Baltimore, Md.
Gimper, John, Leavenworth, Kan.	Stanbery, F. H., Pekin, Ills.
Harris, G. S., Mansfield, O.	Starr, E. M., Richmond, Ind.
Henning, D., Chicago, Ill.	Taylor, Geo. H., Warren, O.
Howard, J. B., Dubuque, Ia.	Taylor, Thos. E., St. Louis, Mo.
Hart, M. S., Las Vegas, N. M.	Keller, C. M., Columbus, Ind.
Jenkins, E. H., Columbus, Ga.	Thompson, J. D., St. Louis, Mo.
Johnson, J. H., St. Louis, Mo.	Watts, S., St. Louis, Mo.
Johnston, R. C., Lawrence, Kan.	Wirt, R. D., Independence, Mo.

Associate Members.

Babcock, H. C., St. Louis, Mo.	Hicks, Geo. C., Chicago, Ills.
Bradley, C. D., Chicago, Ills.	Howard, E. T., St. Louis, Mo.
Connelly, T. E., New York, N. Y.	Howard, L. J., St. Louis, Mo.
Cressler, A. D., Fort Wayne, Ind.	Howell, W. S., Cincinnati, O.
Daniels, Jas., St. Louis, Mo.	McClary, N. A., Chicago, Ills.
Delano, O. D., St. Louis, Mo.	McDonald, W., Albany, N. Y.
Dell, John, St. Louis, Mo.	McIlhenny, John, Phila., Pa.
Dickey, C. H., Baltimore, Md.	Persons, F. R., Chicago, Ills.
Goodwin, W. W., Phila., Pa.	Ranshaw, H., Cincinnati, O.
Graeff, G. W., Jr., Phila., Pa.	Roots, D. T., Connersville, Ind.
Green, Jas., St. Louis, Mo.	Russell, D. R., St. Louis, Mo.
Griffin, J. J., Phila., Pa.	Russell, T. G., St. Louis, Mo.
Harper, H. D., Chicago, Ills.	Stacey, Wm., Cincinnati, O.
Harris, Jos. A., Phila., Pa.	Stout, John, Chicago, Ills.
Hauk, C. D., Chicago, Ills.	Wolfe, L. J., Chicago, Ills.

The minutes of the Ninth Annual Meeting, as published in the AMERICAN GAS LIGHT JOURNAL, were approved.

PRESIDENT'S ADDRESS.

President Fullagar now read the following inaugural address :

Gentlemen :—It is my pleasant duty to welcome you to this our Tenth Annual Meeting, and to congratulate you upon the general prosperity found prevailing in every branch of the manufacturing enterprise in which this Association is so important a factor.

The character of this Assembly makes attendance at our meetings not only a business duty but a social pleasure; and while we enrich our stores of practical information, by a free interchange of opinions based upon experience, we incidentally and purposely illustrate the social side of our dispositions, and also tickle our somewhat neglected palates with the fruits and sweets provided by nature for the deserving.

The only feature of this organization that fails to meet with my approval is the fact that we meet but once a year. "Like seeks like," and, therefore, do minds trained in the same line desire to occasionally "rub

against each other," confident of finding not only valuable suggestions of a practical nature, but constant interchange of congenial ideas.

We meet after twelve months of labor that, no doubt, taught us many new facts; and it is the mutual exchange of these facts that makes this Association of so great importance. In this general expression of ideas it becomes the duty of every member to contribute his unit of information, so that, in the end, we may be in positive possession of all that is good, and so stand on logical basis, having discarded that which is bad.

In this "rounding up" of ideas no doubt many pet theories will have been exploded, and perhaps some sore spots exposed, but the healing balance that comes from intelligent discussion, supplemented by practical application, more than suffices to ease the injuries inflicted. While some of us may go from here far from being convinced that our pet hobbies can find no resting place in sound reason, and with our minds correspondingly depressed thereat, yet being conscious that "pigheadedness" is not one of our faults, are certain that the bud of reason here implanted will, in the course of time, ripen into the rose of positive conviction. Conservatism may be a great virtue in most affairs of life, but when it comes to the development of the gas industry it can find no abiding place. With us it has been, and in all probability will continue to be, an aggressive fight for economical improvements.

We miss to-day from our ranks the presence of a gentleman who, aside from his great worth as an earnest worker for our cause, was beloved by us for his many manly virtues. I need hardly say to you that I allude to our lamented friend and brother, the late Mr. J. O. King, of Jacksonville, Ills., whom the great reaper took from us since our last meeting. To others who well knew Mr. King's merits will be intrusted the sad duty of preparing a minute to his memory on behalf of this Association.

This, our Tenth Annual Meeting, is very appropriately held in the city of St. Louis, where, a decade ago, the Western Gas Light Association first sprang into existence. As an infant it was strong and healthy, and the development of its matured years has demonstrated the wisdom of its projectors. It has enabled us, in many instances, to concentrate intelligent action, where, had we no organization, our forces would have been widely scattered, and our time and money correspondingly wasted.

It has created a brotherhood which binds us in pleasant social tethers; that has enlarged the horizon of our reasoning faculties; that has broadened our business intellect; and that has served as a willing wet nurse to our pocketbooks.

The year that has elapsed since last we met was not very fruitful of improvement in the manufacture of gas, but nevertheless since the formation of this Association the improvements in our special field have been numerous and valuable. It may not be inappropriate at this, which may be called our tin wedding, to make brief reference to some of the past advances. Regenerator furnaces have not only done away with much of the stoker's hardest labors, but have increased the given production of benches over the old method in the proportion expressed by 90:55. Again, the improved furnaces have made a saving in fuel of 25 per cent. over the old method.

During the period of our existence as an Association stoking machines have been introduced, and are in successful operation in six of the large cities of this country. They have caused us a saving of full 20 per cent. over hand drawing. They could be successfully and economically operated in any works using over six benches.

Ten years ago we used no agent save lime for the purpose of purification, which cost us three cents for every thousand feet of gas; but now, with oxide of iron as a purifying agent, we save five-sixths of the named cost. Ten years ago water gas was a comparatively unknown quantity, and any gas engineer or manager who had the temerity to speak respectfully of it was liable to meet with mental if not bodily chastisement; to-day, in all large plants, water gas, in connection with coal gas, is very desirable, for two excellent reasons. First, as an enricher; secondly, as an instrument of moral suasion to be used upon workmen in allopathic doses. It is very effective in both cases.

Ten years ago the gas fraternity was much exercised over the discoveries of the sage of Menlo Park; to-day we can see how idle were our fears. The electric light has proved to be a beneficial boomerang to the gas fraternity in that, instead of inflicting permanent wounds upon our body, has, as we well know, been of material service to us in increasing our gas consumption. Anything that has a tendency to make greater the demand for light must of necessity be beneficial to those interested in the standard illuminant—gas.

Of late we have heard and read of natural gas, at first with some quakings; but, it having been fully established that to enrich the natural article sufficiently to class it among the illuminators requires an expenditure greater than that requisite in the manufacture of coal gas, our quakings immediately disappeared.

A question now facing the gas fraternity, and one of vast importance, is the matter of Gas Commissions. It is a melancholy fact that the great bulk of the people of all cities and towns do not regard the gas companies of their respective places of residence in the kindest light, and municipal governing boards who look upon gas companies as their legitimate prey, do not hesitate to act accordingly.

The general outcry against gas companies arises from one of several causes. First, the desire that most people possess of obtaining something for nothing; secondly, the neglect on the part of the consumers, through ignorance, to regulate consumption; and third, the natural tendency of most well-developed Americans to indulge in what is generally termed a "grand kick." I believe that the first and last causes assigned will cover 99-100 of all objections made to gas bills. While the causes may be deemed light, yet it is not unreasonable to state them as I have. Now, whether it is best to permit the present outcry to continue, and to submit to all the petty annoyances of local politicians, as in the past, or to face a new and untried commission that will, of necessity, be of a political nature, is what the gas fraternity must decide between.

But, gentlemen, I will not detain you by a detailed or lengthy reference to any subject, leaving your superior judgment to determine what is best to discuss. It is my earnest hope that the business which is to follow shall be conducted on the high plane that has ever been characteristic of the deliberations of this Association.

COMMITTEE ON PRESIDENT'S ADDRESS.

On motion of Mr. E. McMillin, the Secretary appointed Messrs. E. McMillin, E. J. King and J. B. Howard, as a Committee to consider the President's Address, and to report their conclusions thereon at a subsequent session of the meeting.

INTRODUCING THE VISITORS.

On motion of Mr. E. J. King, the President appointed Messrs. King and J. B. Howard a Committee to welcome and introduce to the Association those of the fraternity from other Associations who had in person responded to the invitations sent out by Secretary Littleton. In due time the Committee reappeared, accompanied by the following guests:

Mr. C. J. R. Humphreys (Secretary American Gas Light Association), Lawrence, Mass.; Mr. W. H. Denniston, Pittsburgh, Pa.; Mr. F. C. Sherman, New Haven, Conn.; and Mr. H. B. Leach, Taunton, Mass. The guests were greeted in most hearty fashion. The President formally welcomed the visitors, introduced them to the delegates, and invited them to take part in the proceedings.

SOME COMMUNICATIONS.

The Secretary read a letter, from Mr. Jos. Specht, President of the "Famous Shoe and Clothing Company," of St. Louis, Mo., inviting the Association to visit the warerooms of the Company. As a reason for the invitation Mr. Specht explained that the business home of his Company (located at Broadway and Morgan streets) had been formerly lighted by arc lights, but that the latter had been superseded by the improved lamps of the Siemens-Lungren Company—95 of which were now in use. To quote a paragraph of Mr. Specht's invitation, which read, "I think that every gas manufacturer visiting the city of St. Louis at this time is much interested in this (Siemens-Lungren) lamp, for it will, for many and potent reasons, supplant much of the electric light used throughout the country." The invitation, on motion of Mr. Howard, was accepted.

The Secretary also read a letter, signed by Mr. Geo. W. Graeff, Jr., which asked that "the proceedings of the coming annual meeting of your Association be furnished to such journals as may desire them for publication," etc. Mr. Graeff's communication was referred, under Art. VII. of the by-laws, to the Board of Directors, who were instructed to report their recommendation thereon at the afternoon meeting.

LETTERS OF REGRET, ETC.

Secretary Littleton here read letters, from Messrs. C. F. Prichard, Lynn, Mass.; Eugene Vanderpool, Newark, N. J.; A. M. Norton, Nashua, N. H.; Geo. G. Ramsdell, Vincennes, Ind.; C. H. Nettleton, Birmingham, Conn.; M. S. Greenough, Boston, Mass.; and G. A. McIlhenny, of Washington, D. C., regretting the inability of the writers to be present at the Convention.

READING THE PAPERS.

The President—Preliminary routine business having been completed, I will introduce Mr. Frederic Egner, of St. Louis, Mo., who will read his paper on—

AN AMERICAN GAS INSTITUTE.

Mr. Egner read the following:

The matter about which this paper treats, "An American Gas Institute," deals with what at this time is yet an "unborn institution;" but it is hoped that the placing before you now of the idea leading thereto may

lead to the introduction of measures that shall insure its establishment at an early date. Do not, however, expect to hear anything strikingly original in my presentation of the matter, for is it not written in the ancient book that "There is nothing new under the sun?" Each and everyone of the gas managers present has his own idea as to the best way of carrying on the business of gas making, and not unlikely nearly (if not quite) all are right in their views—although these may differ, if compared directly; for we must remember that the prevalent conditions at Cincinnati, Ohio, are not precisely similar to those which obtain at Denver, Colorado. Further, at Cairo, Ills., we may advantageously do that which would prove at Lima, Ohio, to be decidedly in the line of poor policy; in other words, local circumstances and varying conditions must, and do, govern the operations of the gas maker. Hence, even though you concede that "Like causes produce like results"—to which axiom, in the case of the gas maker at least, we must for security's sake add the words, "Under like conditions"—it is only fair to assume that each gas man here to-day understands his business better than any other one could teach him—as applied to his particular location or section of the country. Therefore, keeping all these facts in mind, it has been the object of the writer not to attempt to show you the best way to keep your stand-pipes clear, nor to estimate how much air you may safely mix with your gas, nor yet to descant upon the relative merits of oxide of iron or lime as agents for the purification of gas—because I take it for granted that you are all familiar with these different branches of your art—but I do seek to present to you something that may interest and benefit all, be they visitors from Maine, or members from Texas or California.

The title of the paper may have aroused some speculation as to what this proposed "American Gas Institute" is to be like. What is to be its object or use? What need is there for such an institution? and how much will it cost?

In response to the first of these implied questions, the following explanation is submitted: The American Gas Institute is to be a federation of all the gas companies, or their legal representatives, in the United States—or, for that matter, in America—or as many of these as may be induced to subscribe to the furnishing of the means necessary for the formation and subsequent support of the institution, which preliminary details will meet with a fuller description further on.

The object of this federation or society would be (first) for mutual aid and protection against unfair competition—not *just* competition, mind you; but unfair competition, which, in some instances has degenerated into downright (though legalized) robbery; a highway sort of process, of the meanest order, too, for while it destroyed either wholly or partially the property of the wealthy stockholders, it also swept away the small savings of the thrifty, though poor, shareholder. Further, that pillage has not acted beneficially to the general public, or those not interested pecuniarily in the shares at all; but, on the contrary, the general public have also felt the sting of the marauder's lash.

It seems to me it would be a waste of your time and mine to quote examples in support of the truth of these statements; and so, let us pass on to a second portion of the object of this proposed federation of the gas companies. The second item would be the creation and support of a bureau to gather and furnish to all subscribers general information regarding matters relating to old or new processes or apparatus employed or designed to be employed in any branch of the manufacture, distribution and use of gas for either light, heat or power. To more especially exert a watchful eye over the field of invention; to investigate, and, if possible, to try, all alleged improvements; to sift out and separate the true from the spurious; to report freely all genuine progress to its members; and to warn them against fictitious, impracticable, or otherwise undesirable contrivances, whether in principle or process of manufacture. It may be stated, on good authority, too, that the railroad companies of this country, although their individual interests as separate companies are not unfrequently in direct opposition to one another, for years have had such an organization imbued with the relative object stated in the second place herein—viz., to aid really meritorious inventions, and to discountenance error or fraud.

As has been indicated, mutual protection is the foundation stone upon which the whole plan is sought to be based. "In union there is strength" is an old, tried, and truthful lesson, and it would be well for us to heed its teachings, and to apply them to our own case ere the date available for their employment has passed away. There can no longer be any doubt that had the gas companies years ago acted together in unison or consort millions upon millions of dollars would have been saved their stockholders, and the selling price of gas would, generally, be less than that which rules to-day.

And now we may consider the necessity of or for the proposed organization in relation to the field of invention. This interference can best

be understood by a reference to the records of the United States Patent Office. Indeed, the careful investigator would find, after a search that need not be too searching, himself in thorough accord with the saying that there is nothing new under the sun—in the line of gas generating apparatus or devices—except he took refuge in the belief that a series of “new” combinations, based on old, well-known, and generally understood principles, constituted “new discoveries.” Despite the seemingly endless and exhaustive list already on the records, we are confronted with the hard fact that scarcely a week goes by in which one or more “new processes” are not annexed in the archives to those already born, nay, “hoary with the rime of years,” and heralded as the primal scions of a new race. Again, each week may be trusted to add largely to those vagaries of the inventor’s brain which, not aspiring to the dignity of being proclaimed as “new principles,” modestly shrink behind a garb labeled, “improvements to apparatus.”

To assert that all these alleged inventions were valuable, or in fact constituted any improvement over preceding methods, would be wild, wholesale exaggeration; but, on the other hand, to say that none possessed merit would be most unjust; and yet it is a fact that all meritorious inventions do *not*, at least at first, succeed. They may attract passing notice and then be forgotten, to the manifest injury of true progress. They may be re-invented long years after their original appearance, and their resurrection be attended with happy results. An example of this sort is instanced in the compound engine of the present day, which was proposed by Watts and others of his day and generation. Of course it is easy to see how such original failure may be caused. The inventor may have been a poor struggler against the tide of adverse fortune who, becoming gradually disheartened, will let—because he was obliged by circumstances—the matter drop. But in that event the business or process that would have been benefited in the successful development or fruition of the toiler’s attempt sustains a certain loss, and possibly receives a serious blow, from which it may not recover for years. Perhaps, also, that loss may never have been realized or appreciated subsequently.

Nor do all imaginary improvements, on the other hand, fail to find a market—for a time. During their brief hour of exposition the investors beguiled into attempting to reap profit from their development receive the only recompense that is subsequently to pay them for the conviction that they were deceived and swindled. Now if the “invention” happened to be in the line of a gas process, the action of the bureau attached to the proposed gas institute would go far toward protecting the manufacturers—the people financially interested—from worry and loss.

As an example of one of these deceptive “processes” a certain “oil, air and water gas system” is cited, which was fully described in the AMERICAN GAS LIGHT JOURNAL, on two distinct occasions. The first reference (see JOURNAL, April 2, 1884) dealt with the process as it was claimed to exist and act by the inventor, but the second mention (see JOURNAL, Aug. 17, 1885) disclosed the process as it was found to be from the result obtained in a careful trial by a gas man. That particular process was heralded by its promoters as likely to be equal to the task of supplying nothing less than the long-sought-for “gas of the future,” and notwithstanding the self-evident folly of the method followed—that of running oil and a little water into a red-hot iron retort, made carefully air-tight, air then being pumped into the retort by means of an air pump—the invention found some very respectable indorsers, who upheld it until its inutility was proven beyond reasonable doubt to the parties most interested—the purchasers of the patents. It might be further explained, as another “qualifying” circumstance which clouded the “complete originality” of the “invention” that the apparatus and process were the exact counterparts of a plan patented years before by an Englishman who resided in New Zealand. But to come back to the disgusted proprietors who purchased the “inventor’s rights.”

Did these people drop the matter then and there? Oh, no! Not desiring to lose what money they had invested, the “principle” was revamped, and another patent—based principally on misrepresentation—was granted them. Armed with this document they took in one or more “green” partners, started in under new management, with a new name, of course, and the “right to use the process” is actually being offered for sale, particularly in the Western States.

A further argument in favor of the establishment of an institution like the one proposed is to be found in the apparent uncertainty surrounding the results said to be obtained in the manufacture of water gas as produced by means of well-known systems and apparatus. Would it not be better for all gas engineers (and gas proprietors) to know that, with a stated quantity of oil of known specific gravity, and with the use of just so many pounds of coal or coke, a certain result in cubic feet of a gas of known illuminating power could be depended on? The various

water gas machines are now made so nearly perfect that it seems strange there still should be so much controversy as to the actual results, and hence that the value of these processes still must remain a subject for hesitancy and doubt on the part of many owners of gas works. Could all these matters be settled beyond reasonable doubt by reference to some accepted authority proprietors of gas works would be in position to decide and act in regard to the claims of inventors; and that opportunity would be afforded by the working of the proposed gas institute.

It is true that a number of societies, similar in purpose to the Western Gas Association, are in existence, and that their prime object is to disseminate and promote knowledge necessary to enable their members to cheapen and improve the manufacture of the commodity that we distribute; but no society composed of individuals could reasonably expect to successfully carry on the work that needs to be done. This requires the action of a legally organized body comprising the corporations interested, which necessarily would involve a more liberal expenditure for its support than could be ordinarily expected or exacted from individuals.

If the American Gas Institute were ever to become a fixed fact, in the shape of a real, live institution, it should have an office at Washington, D. C., so as to be convenient to the records of the U. S. Patent Office; and it should also have an understanding with the proprietors of some convenient gas company at whose works might be obtained those appliances necessary to carry on any desired experimentation—of course, that accommodation to be liberally paid for by the institute. Of course, such an arrangement might be trusted to materially reduce the expense for experimenting, as you will see upon slight reflection, and without any further hint from the writer. It is not necessary, in order to try an invention on its merits, to purchase the same; and it will be time enough to buy it when, having decided as to its availability, you have determined to practically employ it. No straightforward inventor would refuse an appeal for the privilege of testing the child of his genius; quite the contrary, he would welcome the opportunity. In regard to the other class (the frauds), their objections would prove valueless, for in exposing their humbuggery we strip them of their power for mischief in the future.

The composition of the institute might be arranged about in accordance with the following: The gas companies subscribing to the support of the institute could annually elect a board of trustees, the ballot to be made by means of a letter vote addressed to the President of the body. The board so elected could subsequently meet and elect a President, an Executive committee, and such other officers as might be determined were necessary to the proper control of the body. The President, Trustees and Executive Committee should serve without compensation, save in the matter of moneys actually expended in traveling, etc., during time of attending the meetings. The Trustees should be empowered to decide the policy of the organization, and to lay out the work, while the Executive Committee should be the active force for carrying out this policy whenever or wherever required. Then a practical as well as theoretical gas engineer should be selected to take charge of the permanent business and office of the Association, at Washington. This officer should be appointed for life, and ought to receive a liberal salary, in order to remove him as far as possible from the temptation to serve other interests than those whose advantage he was retained to guard. If, however, it was suspected that he had neglected his duties, was incompetent, or wilfully misrepresented any matter that he had been called upon to investigate, he should be made the subject of charges to be brought against him officially by the President; the trial court to be composed of the Board of Trustees, or the Executive Committee, or both. If a verdict of guilty were returned the offender should be dismissed, and the facts of the trial and punishment be published to the fraternity of the country. This would provide a double safeguard—not, of course, needed for the hedging in of an honest man—which, in the hour of temptation, even a desperate man would scarcely dare to break through. Thus the subscribing companies might be sure of thoroughly reliable information as to the value of all new inventions, and the officer might, during lulls in the whirl of invention, devote his time to the investigation of older—either active or dormant—subjects, to the manifest benefit of all concerned.

This Chief Engineer should be given the right to employ whatever assistants he deemed necessary, and he should be untrammelled in the right to elect or dismiss these subordinates, to the end that he be held completely responsible for their conduct.

To go at greater length into the routine organization details would no doubt be tedious—indeed, uncalled for—at this stage of the proposition; but the outline so far advanced I deem to be sufficient to prove that such a plan would enable the different gas companies to keep informed about the value of all new (and many old) inventions; and would cause them not only to keep up with, but really to assist, true progress in the science of gas manufacture and gas consumption. This—which was named as

the second of the objects for founding the institute—ought in reality to be the first argument in favor of the organization. It would at once bring all the interested parties closer together, and *keep them so*—having a common object.

The relative cost of maintaining such an institution would be but a trifle, were all to join in the cause. In fact the assessment would not exceed—perhaps not even reach—one mill on each thousand cubic feet of gas sold by each company for illuminating purposes.

Let us examine one or two instances. A company selling five millions cubic feet per year, at the assessment rate proposed, would be called on to pay \$5—not an amount greatly in excess of what is paid for the average village weekly paper; and a company like the great “Consolidated,” of New York city, would be assessed but \$1,250 for the twelvemonth. Neither of these could secure like benefits for a sum anywhere near so small. And yet, at that rate of tax per thousand sold, the income of the institute would be over \$24,000 per annum, exclusive of what those companies, which sold less than five millions cubic feet per annum, might contribute, also excluding natural or purely oil gas companies. However, united (or nearly so) action is necessary to secure the full value of the protective feature of the organization. Without enlarging on this now, it is safe to say that it is a matter which seriously interests all—great and small—gas companies alike. If you delude yourself with such selfishly constituted arguments as, “We are too great and powerful to be troubled;” “our charter is too strong;” “we are too insignificant;” or, “we, having coal and water gas processes, can defy all;” it is more than likely that you will find representatives right now in this meeting room who could, if they chose to relate their experiences, show the practical weakness of all your arguments, and prove to you—let it be repeated—that only in union can be found perfect strength.

Mine is not an argument for either coal or water gas, which you will readily concede; it is an argument for union, for self-preservation, for the protection of the interests of our stockholders, who have intrusted us with their money and the conduct of their business. But, as everybody's business is said to be nobody's business, one waits for the other. At best nothing is done, but in the meanwhile we are being swallowed up one by one, giving up, to soften the process of deglutition of your absorbers, sometimes as much as one-half of your property—simply because some one has had the courage or audacity to demand it from you with a threat.

Do not say, “We tried to unite before, but failed.” “Try, try again,” was one of schoolday rallying cries: and be assured that it is a good one for manhood's days. Let all put their shoulders to the wheel, for you are all interested; and, sooner or later, you will be caught in the toils of the adversary who spareth not—that is, if you do not help to push now. When you go home from here interest your directors and stockholders. Tell them the facts; and act! Push, and keep on pushing, this matter, and when it is fairly started keep on, so that we cannot only have—but also keep our “American Gas Institute.”

Discussion.

The President—The paper is now before you for discussion, and I hope that it will be freely commented on.

Mr. McMillin—I am sorry that Mr. G. S. Page is not now present, for he knows more about this subject, perhaps, than any other member of this Association. He probably would tell us that he devoted six months of hard work, day and night, to an attempt to organize an institution like that suggested by Mr. Egner. In addition to his labor Mr. Page expended a good deal of money which has not yet been returned to him. Quite a number of others did a great deal in that same line. I recollect that I devoted a good many days and nights to a study of the problem. The question has been before the American Association for some years; and correspondence on the subject has been had with almost all the larger companies, and with a great many of the smaller ones, throughout the country. That body went so far at the Cincinnati meeting (Oct., 1885) as to secure a conference of those taking active part in the subject—then involving some 40 or 50 gas companies—and at that conference a committee of 13 was named and instructed to subsequently elaborate a plan for the organization of an institute. Each member of the committee was requested to prepare a paper illustrating his idea of the proper mode of accomplishing such end, then those papers were to be submitted to a sub-committee, and that sub-committee was to prepare a final report. The matter got as far as the sub-committee stage. I think a good many papers were presented, and the sub-committee, or a portion thereof, held a meeting, and subsequently called a general meeting of the committee of thirteen, to be convened at Springfield, Ohio, in the spring of 1886. The 13 failed to report at the designated time; perhaps three of the members reported. It was found that the nearer the work of the committee

approached completion the greater was the opposition to the plan proposed. That plan went even further than that now suggested by Mr. Egner. He suggests levying a tax of a fraction of a cent per thousand cubic feet of output: but they permitted, if necessary, the levying of a tax of five cents per thousand. My company was at that time selling gas cheaper than any other company in the State, and although we did not fear opposition our directors unanimously agreed to favor the plan, notwithstanding it would bind us to pay over some \$6,000 or \$7,000 per annum, in case it were found necessary in any year to raise the maximum amount. But we did not expect it to become necessary, for we believed that the mere ability to raise so large a sum would obviate the necessity of any such levy. The very fact that we had it in our power to make such a levy would tend in a large measure to prevent raiding. I worked very enthusiastically and for a long time in developing that enterprise, and I would be glad now to see somebody else take it up and make a success of it; but I have lost faith in my ability to do anything in that line, and have also lost faith in the ability of the other gentlemen who then had it in charge to successfully carry out the plan proposed. Although, like Mr. Egner, I would be glad to see the thing tried, I have little faith that we shall succeed in establishing an institute of that kind. I anticipated, from the title of his paper, that he would propose to provide for an engineering school, or something of the kind, and that idea impressed me very favorably.

Mr. Boardman—I have been interested in this movement since its inception, or since I have been a member of the American Association, and have carried on considerable correspondence in our section of the country about it. I also took sufficient interest in it to prepare a plan on the outlines given by that committee of 13 (although I was not a member of it), and while preparing that plan it struck me we overstepped the objects we ought to have had in view. We were trying to create, at the very start, a perfected and full grown association, whereas we should, perhaps, have started with a single object, working up from that starting point, subsequently increasing the scope and influence of the project as it grew in years. It is a difficult matter to have anything perfect at the very start, and the greater the scope you try to cover at the start the more opposition you are likely to encounter. One of the chief features of that plan, and the one which met the greatest opposition, was the protective feature, under which unattacked companies were to be taxed to help support those companies that were being assailed. I think that was the rock on which we split. Mr. Egner has only incidentally referred to that feature; but he has considered in his paper the ground whereon most of the companies could come together, or where a start might profitably be made, thus leaving other and subsequent matters to be developed by the institute when in working shape. I think most of the companies here represented would be glad to contribute the small amount of money he speaks of for the dissemination of useful information with regard to new processes. On his plan I think we can all come together, and then if we find that further development is practicable it can be made. Not only are all companies interested in securing exact information with regard to new processes, new machinery, and things of that kind, but inventors themselves are also exceedingly interested in these very things. Those of us who are thinking about increasing the efficiency of our works, by putting in new appliances, would spend more time and give more thought to inventions which, when perfected and patented by their discoverers, we could thoroughly test in all their bearings, and, if found to be all that was claimed for them, their owners could say to the gas interest of the country that their plans had received the indorsement of the institute, and that indorsement would be of value to them and to ourselves. Many of us are not able to carry on such investigations, or to take the steps necessary to get out patents, or to properly advertise and induce other companies to try new processes or machinery; whereas many of us would be very glad to put our shoulders to the wheel and give it a good push if we could be sure of having these new processes or appliances properly tested; I think this point is one we should all consider, and I am heartily in favor of making another attempt to induce the gas companies to act together.

Mr. Thompson—As one of the committee of 13 I will verify the statement that the main consideration then proposed was to enable companies to successfully contend with opposition. The money raised was to be chiefly used for that purpose. That which Mr. Egner makes the chief point was only an incident of the plan then proposed—that of protection against fraudulent patentees. I believe the plan now proposed would meet with favor where the other was frowned upon, and I would like to see it attempted.

The President—Would it not be well to refer this paper to a committee, they to consider and report to us before final adjournment?

Mr. Egner—That was the object I had in presenting the paper. We

are all certainly interested in the matter, and I am satisfied the more the members think of it the more they will approve it. There are a great many things to be considered by such a committee. The incident mentioned in the paper refers to parties who tried to interest people ignorant about gas matters sufficiently to induce them to buy the patents. That practice is not felt so much in large cities as in smaller ones. If there had been an institute the thing could have been investigated and pronounced upon by a competent official. If these investors were posted they would not have parted with their money. The project is not an expensive one, and reflection, I think, will convince you that the money will have been profitably disbursed.

[On motion of Mr. Pratt, the paper was referred to a committee of three (Messrs. Pratt, Egner and E. McMillin), who were instructed to report on the following morning.]

Mr. McMillin—I am sorry that I have been appointed on that committee, for I really feel disheartened at the prospect, judging from the fate of the committee of 13. Messrs. Boardman and Thompson are under the impression that the defensive feature was the *prominent* one in our former attempt, but I think its seeming prominence was due to the fact that it caused dissension. In fact the paper that was finally agreed upon by the sub-committee put very much more stress upon the testing of inventions and processes, and similar objects, than upon the protective feature. I think, however, that the disagreement generally attached to the protection feature, and in regard to those eligible for membership. Companies with fights already on hand of course could not be taken in. As to how (provided they would) we should come in—whether on the basis of capital stock, or the amount of gas made or sold—were the troublesome points.

Mr. Lansden—I want to say that, in my opinion, the cause of failure heretofore has been because of the attempt of superintendents and engineers to dictate to capitalists about how they shall take care of their stock. My experience has been, as a general thing, that those who own the stock, so long as their dividends are paid, and they are not afraid of being interfered with by some other company, have no heart in the matter at all. I find that stockholders who expect a raid is about to be made on their property, or when they are anxious to influence the City Council, are apt just then to be most anxious about studying up the methods of gas manufacturing; but their fever for information passes away with the removal of the danger clouds. I do not believe that the proposed institute can be successfully established, because capital is satisfied so long as it receives dividends. Capitalists want you to earn their interest, and will say that that is what they pay you for doing.

Mr. McMillin—There is, perhaps, a good deal in what Mr. Lansden says, but his assertion is hardly borne out by my own experience. At that time of the committee of 13 I represented five companies, in four of which I could do as I pleased about it. Neither of the four had anything to fear from competition, yet I signed for them all. In the fifth company we sold gas at a price that precluded an opposition onset, and in the latter instance I simply recommended the project favorably to my board of directors, who authorized me to agree to the proposition. In those five cases it was not fear of competition that induced the companies to assent.

Mr. Thomas—I believe Mr. Egner submits a proposition quite different from that considered by the committee of 13. The latter plan was not entirely original with them, for the same suggestion was made 25 years ago, and had it been then adopted and carried out we would not have been witnesses to the wholesale raiding that the gas business has been subjected to in the last decade, or so; but as I understand Mr. Egner's paper, he simply proposes to get at the facts—to find out if any of these new inventions are meritorious and worthy of adoption. As he said, hardly a day goes by but someone obtains a patent for a machine or process, when a little later on someone else produces another machine or process, almost identical in principle with the first, but the parchment is secured on the ground of an "improvement." Nevertheless, some of these systems may contain something which it would be worth while for all of the gas fraternity to be advised about. The adoption of Mr. Egner's plan would secure this advice at very slight expense. The committee of 13, as I understood their aim, proposed to levy assessments to be used in the attempt to prevent the success of opposition schemes. It appeared to many that some of the gas companies were to be called on to pay a pretty high figure for the strengthening of a few; but how would it have worked? For my part I believe if the plan mooted in New York city over 25 years ago had been put in operation, and prosecuted vigorously, the raiders would not now be in the possession of quite so much capital. Mr. Egner's plan (it seems most feasible) can be started on a modest scale, and be brought to full fruition in the future. As outlined by him, I believe that an expenditure of \$10,000 per annum would in-

sure an amply satisfactory commencement; and what would that sum be when assessed on the total output of the gas companies of the country? In my opinion that tax would be the cheapest one ever levied on the gas makers, remembering the solid benefit they would derive from the bulletins of the institute. I know something of the trouble mentioned by Mr. McMillin with regard to the difficulties encountered by the committee of 13. I had a great deal of conversation with Mr. Page at the time, and helped along the matter as far as I could; but as soon as the details were placed before the larger companies, or when they understood what their assessments would be if the plan were carried out, they voiced their objections. They seemed to think it would be nonsensical to pay large amounts of money, not for the purpose of sustaining themselves, but to help along some of the smaller fry. But the present movement is of an entirely different character. Here they will be asked to pay only for valuable information. What may grow out of it must be left for the future to determine.

Mr. Watts—I would suggest that the committee consult with the Railway Association, whose headquarters, I think, are in Chicago. That Association is supported by several of the railway companies of the country for the purpose of examining the different appliances incident to their business. The members of the Association each pay their proportion of the expense of obtaining the information, and none but members receive the bulletins. I think we might arrange it so that only those companies composing our institute could have the benefit of the information obtained by the institute. The Railway Association have a permanent secretary, and he names certain members of the institute to investigate and pass upon any special appliance that is brought up. It is not part of their purpose to prevent opposition, but merely to examine new appliances, and to obtain statements as to the value of these from men who are capable of giving correct information.

Mr. McMillin—I think that we are following right along in the old footsteps. Three or four members of the committee of 13 can quote, from A to Z, the rules, regulations and articles of association of that Railway Association. In fact they studied them so carefully that they became much more familiar with them than they probably are with their own by-laws. This Railway Association is the one after which all similar organizations are modeled, and is probably the most successful one in the country. I would, if I could, disabuse the minds of members of the idea that the chief feature in our former plan was the defensive one. It was not so. The very features now recommended as desirable were the chief features of the plan virtually agreed upon. The idea of the large assessment was very much like the guarantee fund of certain organizations—they get up a guarantee fund for effect, but do not expect to have anything to pay.

The President—They get beaten occasionally.

Mr. McMillin—Occasionally they are assessed a trifle. If it were possible for an association by assessment to raise \$100,000 for the purpose of defeating a raiding party, the raiding party would not be apt to make the attempt. It was never expected that any greater assessment would have to be actually made than you would have to make under the present plan suggested.

Mr. Cosgrove—This is a subject entirely new to me, but Mr. Egner's paper causes me to look on it as a grand good thing. I am willing, on behalf of the Evanston (Ills.) Company, to pledge myself to pay its pro rata towards the expense of carrying on an institute of the kind proposed. Almost all scientific bodies have their technological and polytechnic schools. As I understood the circular issued by the committee of 13, their proposal was in the nature of the organization of a protective association, and intended chiefly to afford protection from raiders. The plan now proposed is for an organization of a higher order, and on a grander scale.

The President—As far as I understood the Cincinnati meeting project, that was principally intended to benefit small companies, in respect to everything connected with gas works plant. But every engineer or manager of a gas works has his own particular hobby. If one prefers a 20-inch D-retort, another holds out for a 15-inch vessel; one man has a mouthpiece of a peculiar shape, while his neighbor desires something different. The trouble is to get managers and engineers to agree to one general plan in anything, and that is what we have got to come to before we can achieve success. The first appeal must be made to the managers and engineers of works; and there should be some uniformity about the plan of laying out plants. We should come together to find out the best plan, and when we have done so, then you can carry out the Egner suggestion, but not before. The idea of Mr. Egner is, to my mind, a good one.

Mr. Egner—Our honorary member, Mr. Harbison, is here, and we would like to hear his opinion on this question.

Mr. Harbison—I have not given this matter very much consideration. I attended one of the first meetings called to consider the Cincinnati proposition, and must say that my impression in regard to the object of the organization was like unto that of many gentlemen who have expressed their opinions here to-day—that the fund to be raised was principally for purposes of defence. I did not favor the formation of an association with that special object in view, because I did not think it would be fair to those who had been sufficiently progressive in their business to reduce their selling rates to a scale which offered no special inducement for raiders to attempt to divide the profits of the business. I do not quite agree with Mr. Lansden that stockholders would not be specially interested in this matter. Perhaps they would not be expected to have an interest, because they are not well informed. They depend upon their managers for the carrying on of their business, and for the dividends which they know are pretty sure to come to them at certain periods of the year. I do not quite agree either with the suggestion of my friend Watts, that only members subscribing to the expense of obtaining this information should have the benefit of the information obtained. I have always said there were no secrets in the gas business, that we are a party of men engaged in an honorable profession, and that we are ready, therefore, to show our hands and our books at any and all reasonable hours of the day, and sometimes in the evening; that we are as ready to give information as we are to give light, and that of the very best, for the benefit of those who may ask us with regard to it, or seek the light which we have to give; and there are very few of us who can get along without such aid. What do we have this organization for, and what do we come to these meetings for, if not to give and get information from each other? If a number of the members of this Association should belong to the proposed gas institute, when organized, and should come here with secrets locked up in their bosoms—secrets of information derived by that organization in its investigations—are we to suppose that the members who belong to such an institute, and have that information, would not answer the questions which would be asked in this meeting? I cannot believe it to be so. Why, sir, those of us who live in the East, and have not yet attained to the eminence reached by the members of this Association in carrying on our business, come here for the sake of learning from you, so that we may go back in some measure approaching to the degree of excellence and perfection attained by you here. I should feel very much discouraged if I thought I could not come here in the knowledge that men like McMillin, Howard, Lansden, and the other lights of this Association, would freely tell me what they knew of advance in our common calling. I think an organization like that proposed by Mr. Egner would do much good; but I do not think we shall all ever attain to that condition where only one style of bench, retort, mouthpiece, etc., will please us. Suppose the institute passed its word that such a bench was a better one than that which my friend McMillin is using, or that which our worthy President approves; would that fiat prevent McMillin, for instance, from adopting a bench that he liked better than the one stamped as “good” by the seal of the institute? I think McMillin would be apt to follow his own opinion in that event. But a good deal of information of great value to those seeking for it would be secured, at but slight expense, were the institute an established fact. It is quite an important matter, and I heartily favor the trial of such an organization. I think that the management being in the hands of the fraternity it would be conducted as all gas business is—on straightforward, honest business principles. That there would be no misrepresentations made; and, if the stamp of the institute were put upon any invention, or of any kind of system, it would be of value, and could be relied upon by anyone engaged in the business, whether a member of the institute or not.

(To be continued.)

New Process for the Protection of Iron.

The *Scientific American* says that the process of preserving iron from oxidation may fairly be termed one of the great issues of the present day. Hitherto it has been effected in widely opposite ways. One method has consisted in converting its surface into an oxide, another in applying paint or enamel, another in coating it with zinc—a metal more readily attacked than itself. All these methods bear the aspect of being expedients merely, and do not present a definite solution of the problem.

Of all the ordinary metals, lead, which resists some of the stronger acids, such as sulphuric or hydrofluoric, may be regarded as the most durable. A new process of coating iron with an adherent layer of this metal has recently been discovered and perfected by Mr. F. J. Clamer, of the Ajax Metal Company, of Philadelphia. By it the iron is covered with a uniform coating of silvery lead. The roughnesses and indenta-

tions of the iron receive the lead, as well as the smooth parts. The result is a perfectly protected piece as long as the lead endures, and it is practically everlasting. No oxidation can affect the iron.

We have before us some admirable specimens of work done under this new process. It is specially adapted for the protection of sheet iron for car and other roofing, for spikes, bolts, nuts, pipes, boiler tubes, water tanks, iron bridges, and wherever the protection of iron or steel, wrought or cast, is desired. Its cost is no greater than that of the ordinary zinc or galvanic process. The superior excellence of the new method, its comparative cheapness, and the wide range of its applications, mark it, in our opinion, as one of the most important of recent improvements in the useful arts.

Translated for the JOURNAL, from the *Journal fuer Gasbeleuchtung*, by “A. S.”* (Concluded from page 318.)

Has the Length of the Photometer Bar any Influence in Determining the Results of the Observations?

By D. COGLIEVINA, C.E., Vienna.

The correctness of this equation can easily be proved by considering that the numerical value of the same must have no influence upon that of the proportion $\frac{J}{R^2}$, and must consequently be = 1, when $e = 0$. And, indeed, we have for

$$\frac{1}{3} \left[\frac{2R^3}{(R^2 + e^2) \sqrt{R^2 + e^2}} + 1 \right] = 1$$

then

$$R^3 = (R^2 + e^2) \times \sqrt{R^2 + e^2};$$

but since we have, as appears from the diagram (see May 16),

$$R_1^2 = R^2 + e^2,$$

that, when substituted, gives $R = R_1$ and $e = 0$.

We will now proceed to find the influence of K upon the value of each respective observation—that is, to compare the readings from the bar with the values furnished by equation (1). For this purpose we will assume that the observations be taken one after another, on two bars of unequal length. In the first instance let the constant distance between candles and disk be $a = 0.5\text{m}$; in the other, $a = 0.2\text{m}$. An equal illumination of both sides of the disk to be obtained in the first instance at $R = 2\text{m}$; in the other at $R = 0.8\text{m}$. Then we would obtain, in either case, readings of an intensity—

$$J = \frac{R^2}{a^2} \text{ candles.}$$

But considering that, instead of the proportion $\frac{J}{R^2}$, we have actually to use $\frac{J}{R^2} \times K$, we have the intensity in question given by the equation

$$J_1 = \frac{R^2 \times H}{K}$$

Now, what would be the value of J_1 —

- | | |
|---------------------------|--|
| 1, for $e = 0.03\text{m}$ | } with $a = 0.5\text{m}$ and $R = 2.0\text{m}$? |
| 2, for $e = 0.06\text{m}$ | |
| 3, for $e = 0.03\text{m}$ | } with $a = 0.2\text{m}$ and $R = 0.8\text{m}$? |
| 4, for $e = 0.06\text{m}$ | |

Example 1.—Here we have

$$h = \frac{i}{a_1} = \frac{1}{0.25} = 4, \text{ and then } J_1 = \frac{R^2 \times h}{K} = \frac{4 \times 4}{K} = \frac{16}{K}$$

Now, since

$$K = \frac{1}{3} \left(\frac{2 \times 8}{4.0009 \times 2.00022} + 1 \right) = 0.99978,$$

we have, consequently, $J_1 = 16.00352$ candles.

Example 2.—There we have also

$$h = 4 \text{ and } J_1 = \frac{16}{K}; \text{ but}$$

$$K = \frac{1}{3} \left(\frac{2 \times 8}{4.0036 \times 2.00089} + 1 \right) = 0.99910,$$

and then, $J_1 = 16.01441$ candles.

* TRANSLATOR'S COMMENTS.—I believe Herr Coglievina is in error in the matter of infiltration of air into gas mains under pressure. No doubt, the longer the bar the more exact will be the results, providing there is light enough thrown upon the disk; yet, to take proper readings, neither can the employment of an excessively broad (or long) flame lead to exact results. In this connection, however, I think the author errs in preferring the Argand to the batwing simply because its flame is not so wide, because its flame is, on the other hand, a great deal longer, and its extreme points are probably just as far distant from the optical axis in a vertical distance as those of the batwing in a horizontal one. I also think that the diameter of the transparent part of the disk, as compared with the size of the luminous zone of the flame, will make some difference,

Example 3.—We have

$$h = \frac{1}{0.04} = 25, \text{ and } J_1 = \frac{0.64 \times 25}{K} = \frac{16}{K}; \text{ and}$$

$$K = \frac{1}{3} \left(\frac{2 \times 0.512}{0.6409 \times 0.80056} + 1 \right) = 0.99859$$

Consequently $J_1 = 16.02259$ candles.

Example 4.—Here we have also

$$h = 25, \text{ and } J_1 = \frac{16}{K},$$

$$K = \frac{1}{3} \left(\frac{2 \times 0.512}{0.6436 \times 0.80224} + 1 \right) = 0.99442,$$

and $J_1 = 16.08978$ candles.

To avoid any misunderstanding we will say right here again that these intensities are by no means the real values, because they are based upon the arbitrary assumption that the readings of the bar only depend on the proportion, $\frac{R^2}{a^2}$, and are not influenced by the proportion $\frac{h}{H}$ in any way. Therefore no definite value need be attached to the above figures; but by comparing them we will be enabled to gain an insight into the circumstances in question.

From a comparison of examples 1 and 2 with 3 and 4 it follows:

“That, entirely independent of the length of the bar, our present method of photometrical observation of a given flame leads to an error, which error is in direct proportion to the width of the flame.”

And we further learn, by comparing examples 1 and 3, and also 2 and 4—

“That, independent of the width of the flame, our present method of photometrical observation leads to an error, which error is indirectly in proportion to the length of the bar.”

And finally, by comparing examples 1 and 4 we find—

“That, in order to diminish as much as possible errors which must be expected to occur with our present method of measuring light, the use of long bars and narrow flames is to be recommended.”

III.

We think that great strides toward the final solution of the photometrical problem will be made when the eminent importance of the above recommendation becomes generally recognized. It expresses unmistakably the demand that, in order to arrive as nearly as possible at even results of observations, two equally important items must be decided on; that is—

1. The style of burner.
2. The length of the photometer bar.

As regards the selection of the burner, the above expressed recommendation undoubtedly prohibits the use of the batwing type in connection with photometrical observations, especially since the flame of this burner is so much wider than that of the candle, and, consequently, the factor, K , can never be just = 1. On the other hand, when an Argand burner giving equal light is used, where the difference between the value of, e , and the width of the flame of the candle is much smaller, this otherwise one-sided influence is now brought to bear nearly evenly on both sides of the disk and, therefore, disappears from our calculation. Furthermore, we have to take into account the important circumstance that, in the case of the Argand, the intensity of the flame is spread evenly over the whole width of the luminous zone, same as assumed in the above examinations, whereas in the batwing the greatest intensity lies by no means in the line of the optical axis, but rather in those parts of the flame which only partly exert their influence. Since the degree of this lack of uniformity in the distribution of the light varies with every particular batwing burner, we may come pretty near the truth by attributing to just this circumstance the principal cause of the differences in observations with such burners.

A proper choice of the length of the photometer bar must, if the value of the intensity to be measured and the width of the corresponding flame are equally to be considered, conform with the condition expressed in the equation—

$$K = \frac{1}{3} \left[\frac{2r^3}{(R^2 + e^2) \sqrt{R^2 + e^2}} + 1 \right] = 1$$

or—

$$R^3 = (R^2 + e^2) \sqrt{R^2 + e^2}$$

Now, we have—

$$J = \frac{R^2}{a^2}, \text{ and } R^3 = R \times a^2 J,$$

consequently

$$R \times a^2 J = (R^2 + e^2) \sqrt{R^2 + e^2}, \text{ and}$$

$$a = \sqrt{\frac{(R^2 + e^2) \sqrt{R^2 + e^2}}{R \times J}}$$

To eliminate from this equation the value of R , it is quite necessary to determine that degree of light required to take readings with the most exactness. If n denotes this (as yet unknown) degree of light, we have

$$n = \frac{J}{R^2}, \text{ and } R = \sqrt{\frac{J}{n}}$$

Substituting this value of, R , into the above equation, we get

$$a = \sqrt{\frac{\left(\frac{J}{n} \times e^2\right) \sqrt{\frac{J}{n} + e^2}}{J \times \sqrt{\frac{J}{n}}}}$$

This equation shows at a glance the important fact that the value of a remains constant, as long as the factor e^2 may be neglected, which is certainly correct in the case of examinations of light as generally called for in our contracts for gas supply, and when using an ordinary Argand burner. The above equation is then simplified thus—

$$a = \sqrt{\frac{1}{n}}$$

In a general way the length of the bar is

$$L = a + a \sqrt{J} = a (1 + \sqrt{J})$$

If gas men could agree upon a proper value of n , same as was fixed once before on the basis of the well-known results of H. Cohn, “That for obtaining proper readings a light of 10 meter candles is required,” then

$$L = (1 + \sqrt{J}) \sqrt{\frac{1}{n}}$$

is the proper length of the bar, which will allow readings up to an intensity J , and is consequently the standard length. To reach this end, the authority of the results of some experiments is only wanting, the making of which we would warmly recommend to the Society of German Gas Engineers.

SPECIAL ENGLISH CORRESPONDENCE.

COMMUNICATED BY NORTON H. HUMPHRYS.

SALISBURY, May 10, 1887.

Another Steam Roller Case.—Gas for the People.—A Reckless Corporation.—Another Suggestion as to Selling Sulphate.—Natural Gas in England.—New Applications for Coal Tar.

The local authorities in the West End of London appear to be rather partial to litigation. Some time since I noticed the fact that the Gas Light and Coke Company, which supplies that district, had succeeded in securing an injunction preventing the parish authorities of St. Mary Abbots, Kensington, from using a 15-ton steam roller for the repair of the roads, on the ground that it injured the gas pipes, causing loss to the gas company, and also inconvenience to the public. A neighboring parish—St. Georges, Hanover Square—refused to recognize this decision and persisted in using a roller of similar proportions, notwithstanding the fact that breakages of mains and one or two explosions were traced to it. So the company had no alternative but to spend money (which otherwise would have gone to reduce the price of gas) in proceeding against the parochial authorities. The case was tried at the High Court of Justice, before Justice Grove and a special jury. The company wisely engaged the best legal advice attainable, and produced quite an army of witnesses. In addition to their own employees who proved the facts of the case, that the breakages in question were due to no other cause than the use of the steam roller, there were engineers and iron founders who certified as to the quality of the pipes used, representatives of some of the best firms of gas engineering contractors, and consulting engineers experienced in road work and pipe laying of all kinds. Eminent road contractors, and also a large number of surveyors employed by local authorities in London and elsewhere, certified that the use of such a heavy roller was by no means necessary, as roads could be repaired or made quite as economically with a roller of about half the weight. Although a great difference of opinion prevailed on this subject, the majority were in favor of a roller weighing 5 to 7 tons. Against this the vestry relied mainly on the evidence of their own surveyor, and the ingenuity of counsel to pick out flaws in the evidence. The surveyor

had tried experiments in the way of burying an egg, a whiskey bottle, and a piece of gas main pipe, and running the roller over them, of course without injury to either. But he did his case harm rather than good by trying to prove too much. It was never asserted that the roller crushed up every pipe along its track. The argument was that here and there were soft places, due to the top crust being worn away more than usual, or to subsidence under the pipes caused by drainage operations or other excavations. Under these circumstances the whole weight of the machine may bear down on the pipe, and there may be a contributory cause in the shape of a service inserted into the main, thus weakening it. These of course are the exception and not the rule, and, therefore, the experiments of the vestry surveyor were beside the mark. A piece of gas pipe, loose, is under different conditions to a line of pipe jointed up, and drilled here and there for services; and he probably knew better than to risk the safety of his whiskey bottle by burying it in made ground without a good protecting crust. After a brief deliberation the jury found that the pipes had been broken by the defendant's roller; that the use of such a roller was not reasonable or proper under the circumstances; that it was not used with sufficient care; and that the plaintiff's pipes were reasonably and properly laid. Justice Grove thereupon granted an injunction with costs. It is rumored that this decision will be appealed against; but meanwhile, if the road authorities persist in using the roller, it will of course be at their own risk.

It is remarkable that a suggestion which bears the mark of a step backward should emanate at about the same time from such different quarters as the meetings of gas engineers in the States and the columns of our *London Journal of Gas Lighting*. An itinerant preacher once stated that he knew honesty was the best policy, for he had tried both; and with regard to the use of the gas meter, those whose experience dates back to an era earlier than the introduction of this much abused but nevertheless wonderfully ingenious machine, are unanimous in their opinion that the plan of supplying "by meter" is a very great advancement on the old system of supplying gas by contract. Yet now we find it suggested to go back to pre-meterite times. Some of the American gas engineers supply gas stoves at fixed rates, and others suggest competition with the electric light by putting in large gas burners and supplying them with gas at a fixed annual charge. And the *Journal of Gas Lighting* suggests, as a means of popularizing the use of gas amongst the poor, that artisans dwellings should be furnished with every appliance necessary for the use of gas, and that a fixed charge of a few pence per week should be made for each light, the same being calculated to cover both the cost of the gas used and the wear and tear of the fittings. Circumstances alter cases, and the one thing that has suggested this apparent retrogression is simply—competition. Here it is cheap oil; in the States it is electricity. Let us all do our best to sell as much gas as we can, whether it goes through a meter first or not. What with differential prices, special terms for day or for summer day consumption, and meters to register each class, and the contract system inclusive of appliances or otherwise, gas consumers ought to be satisfied. But they never will be, unless some ingenious inventor can hit on a plan that will enable "everybody to have gas cheaper than everybody else."

The town authorities of Weymouth, a popular south coast watering place, have been indulging in the pleasant but not profitable occupation known as "reckoning on the chickens before they are hatched." Towns of this description have lately become very enterprising in the way of "improvements," such as piers, esplanades, parks, etc., that are likely to add to the attractions offered to visitors, the costs being defrayed out of the public rates. And in some cases these plans—such for instance as a pier, where a small charge per head can be made for admission—have turned out a profitable investment. In other cases the reverse has been the case, and the rates are very high. Some members of the Weymouth Town Council, seeing that certain embellishments of this nature might be added to their town with advantage, hit over the happy idea of buying up the gas company and the water company on profitable terms, and applying the profits earned by these undertakings to the costs of these improvements. A bill was accordingly promoted in Parliament for powers to carry out this scheme, and after some \$3,500 had been expended in preliminary expenses, affairs came to that stage when the consent of the companies was needed. On this being solicited both undertakings declined to enter into the matter, so all that can be done is to get "permissive clauses," giving powers for the corporation to agree with the companies, inserted in the act. The matter is still under discussion, but it appears probable that the Corporation, if they get the improvements, will have to pay for them in a straightforward manner; and some of the ratepayers are beginning to ask, with more force than politeness, what benefit is likely to be received by them in return for all this expenditure.

In March I referred to a plan that had been tried for increasing the local demand for sulphate, and now have to describe another, which has been introduced by Mr. J. F. Bell, of Stafford, with such success that he is now disposing of the whole quantity of sulphate made at the Stafford Gas Works amongst local farmers. This was simply to employ a firm of artificial manure merchants, having a good connection amongst farmers, as agents for its sale. The difficulty existing in the way of the direct introduction of sulphate to the users by gas companies is not likely to be lessened by the merchants who are accustomed to supply artificial manures, seeing that the result is likely to be a loss of trade to them, and, therefore, the idea of securing their co-operation recommends itself at once as being worthy of imitation. I have repeatedly alluded to the desirability of using the sulphate in the locality or neighborhood where it is produced, so as to avoid loading it with heavy transit expenses, which must eventually fall on the user. Mr. Bell also points out that 4 cwt. of sulphate is as efficient as 5 cwt. of nitrate of soda—a fact which should be prominently brought before the farmers, now that sulphate and nitrate are, weight for weight, about the same in price.

At a recent meeting of the Manchester Geological Society the subject of natural gas was treated upon in a paper read by Mr. G. H. Kirkham, who, after alluding to the extent that its utilization, both for lighting and heating purposes, has acquired in America, proceeded to deal with its existence in the coal measures of this country, and suggested that it should be turned to account in some way, thereby obtaining some value from it, and at the same time relieving the miners from the dangers due to its presence. His idea seemed to be that borings might be made, and the gas collected at the surface of the ground. The paper was discussed at length at a subsequent meeting. It is evident that the success or otherwise of the plan must turn upon the existence of a large supply of gas, and it was questioned whether that given off in coal mines, or contained in the ground in their neighborhood, was either sufficient in quantity, or regular in supply, to the extent necessary for its utilization. Experiments had been made on a small scale in the way of utilizing such gas in the Wigan district; but the supply was irregular and the quality very poor, so the experiments were dropped as likely to secure no practical result. Another speaker remarked that the natural gas in America did not come from the coal measures, and it appeared that the condition for obtaining anything like the volume or quality of gas that is found in the neighborhood of Pittsburgh, Pa., does not exist in this country.

Two new applications for coal tar, both of an astounding character, have been announced. A Mr. James Hargreaves, of Widnes, claims to have made an engine which is capable of developing 30-horse power and upwards, and consumes only two gallons of tar per hour. Any suitable liquid can be used, such as crude petroleum, intermediate oil, or waste. It is needless to point out that the cost of working this engine, seeing that the fuel can be obtained at two cents per gallon or so, would be a mere fraction as compared with that of an ordinary steam or gas engine. Not only does it appear that a vast amount of potential energy can be developed from coal tar, but also a great illuminating value. An appliance known as the Lucigen light, consists of a simple device for converting oil into spray, by means of compressed air, and burning this spray from the mouth of a large tube. It cannot be used on the small scale, and it makes a hissing noise. But for lighting large workshops, open spaces, etc., it is found to be very successful in developing a great amount of light at a small cost. Mr. J. Smith, of the Rosewell gas works, has tried gas tar in one of these lamps, and finds that it gives a flame some two feet high by five or six inches broad, having an illuminating power of more than 2,000 candles, the consumption of tar being less than two gallons per hour.

Surely, it is one of the marvels of this age that a fluid which, if we believe all we hear, is capable of developing a vast amount of potential energy, either in the form of heat or power, of supplying a brilliant light, of yielding an endless variety of solvent, lighting or lubricating oils, that contains such useful substances as creosote, carbolic acid, and albolite, to say nothing of the rare dye stuffs, essences, and medicines that can be extracted from it, and the fact that one-half to two-thirds of it consists of pitch which is always in demand for various purposes—that may be used in its crude form as a paint or preservative, for making asphalt, or in the production of artificial fuel—should yet be a drug in the market, at the absurd price of one cent per gallon, or less.

SIBERIAN EXHIBITION, 1887.—It is arranged that a Scientific and Industrial Exhibition of Siberia and the Ural shall be held at Ekaterinburg in July and the first half of August next. The Exhibition is organized by the Uralian Society of Natural Science, and is divided into nine sections, including natural history, anthropology and archæology, mining, manufactures, domestic industries, fine arts, etc.

ITEMS OF INTEREST FROM VARIOUS LOCALITIES.

DENVER (COL.) GAS MEN AT WORK.—Engineer Fay intends to keep the Denver plant up to the highest standard, and has determined that, to compass the desired object, a pretty heavy expenditure will have to be made this summer. The plans for the extensions have been agreed upon, and, if we mistake not, the Smith & Sayre Manufacturing Company is under contract to furnish the necessary machinery. While not certain as to the nature of all the apparatus to be supplied, we do know that a "Standard" washer-scrubber, equal to handling one million cubic feet of gas per diem, is to be installed. Mr. Fay, in consequence of this determination, will not be able to sniff the salt breezes of the Eastern coast line during the summer dog-days; but when he "comes on to the meeting" next October, the Atlantic Ocean shall still be able to extend a greeting which, though perhaps somewhat cooler than if he came in August, nevertheless will yet be regal, if not tempestuous.

DULUTH (MINN.) ALSO IN LINE.—At a Directors' meeting of the Duluth Gas and Water Company, held something over a fortnight ago, a comprehensive scheme of plant extension was discussed, and the outlines of same were partially agreed upon. The non-resident representation on the board was quite large—Messrs. W. O. Cole, of Chicago, Ills.; J. J. Moffat, of Watertown, N. Y.; and W. H. Doulton, of Portland, Me., having been present—therefore we presume that the work to be done is to be on a large scale.

CHANGES AT DETROIT, MICH.—Recent advices go to show that Supt. E. M. Breese has resigned his berth in the Detroit gas works, and that Mr. Francis Dunlap has succeeded him. James Findlay is to assist the latter. We are right sorry that Mr. Breese could not see his way clear to remain in charge, particularly so when one remembers the high sense of fairness possessed by the executive management of the Detroit Company. We hope that our information is incorrect; and that "hoping" is a good deal out of line with the usual run of newspaperdom.

ANNUAL ELECTION, GLENS FALLS, N. Y.—At the annual election of the Glens Falls Gas Light Company the following officers were chosen: President, F. A. Sabbaton; Vice-President, Jones Ordway; Sec. and Treas., E. T. Johnson; Supt., H. A. Brooke. The Directors comprise Messrs. F. A. Sabbaton, Paul S. Merrifield, Jones Ordway, R. Kipp, D. H. Cowles, E. T. Johnson and H. A. Brooke. In further connection with the artificial lighting supply of this town we understand that the Glens Falls Electric Light Company—it has been in existence since '84—proposes to bring its capital stock up to \$35,000, for the avowed purpose of securing whatever privileges the Thomson-Houston Company may or shall secure from the town. It might be just as well to note the fact that the local company could possibly get along without following out the "pig in the poke" system; but perhaps the Thomson-Houston folks want the "pig," and are willing to leave the "poke" to the local branch, supported, of course, by "home capital." Another grandiloquent reason for increasing the capital stock is said to be to provide for the "establishment of a large steam plant for street, commercial, and, possibly, private purposes." Oh! how these bubbles "float;" and how great is the per cent. of alka(li) in the soap which gives tenacity to the frothings of the bubblers.

WORCESTER (MASS.) ITEMS.—At a meeting (May 18) of the Directors of the Worcester Gas Light Company the official verdict of the Gas Commissioners, in the case of the gas consumers vs. the Company, was received and read. The Board thereupon voted to reduce the price of gas, from and after first prox., to \$1.80 per thousand, with a discount of 30 cents per thousand for prompt payment, equivalent to a net rate of \$1.50. Prompt enough acceptance of the Commissioners' recommendation is signified by that action; but it is an open secret that if President Sargeant and Brother Rollins had all to say about these things the reduction would have been granted long ago. The director who "wants it all" has had his day in Worcester, and peace be with him in his downfall. The city authorities have made a contract with the local electric light suppliers whereby the latter are to perform the public street lighting for three years, for the sum of 60 cents per light for an all-night service. It is an easy matter, however, to enter into such a contract with the Worcester authorities, but it is somewhat harder to obtain pay therefor. The Worcester Gas Light Company will probably agree with us in the latter statement. Then, again, 60 cents per light per night is a good round figure nowadays for arc lighting. The Lincoln square holder is ready for duty. Our editorial columns contain mention of the verdict of the Gas Commission as alluded to above.

PERSONAL.—Mr. James H. Walker, who for the past six years has been in the service of the Parker-Russell Mining and Manufacturing Company, St. Louis, Mo., is now in the employ of the Fuel Gas and Electric Engineering Company, of Pittsburgh, Pa. Mr. Walker is in charge of the gas department of the Company's business. We wish him all possible success.

AN ECHO FROM GRAND RAPIDS, MICH.—Not long ago Mr. Thos. D. Gilbert, Secretary of the Grand Rapids Gas Light Company, enabled us to tell the fraternity that cheap gas rates (maximum, \$1.50, minimum, \$1.20) would prevail in the capital seat of Kent county from the first day of current year. We can supplement that announcement now by saying that Brother Gilbert is superintending the erection of a double-lift holder, to have an estimated capacity of 300,000 cubic feet. The moral is plain and profitable. Cheap gas necessarily involves plant enlargement, and the establishment of peaceful relations with the consumer.

DEATH OF MR. LEWIS.—We regret the necessity that compels us to record the death of Mr. David S. Lewis, a well-known resident of Boston, Mass., whose demise occurred in that city, on Tuesday, May 17. Deceased was born in Rochester, Mass., in 1844, and graduated (in 1872) with high honor from the Massachusetts School of Technology. For several years thereafter he occupied a chair in the Bussey Institute, subsequently taking service with the Boston Gas Light Company as its chemist. Deceased was a thoroughly cultured gentleman, and his studious disposition, bright intellect, and purity of purpose well qualified him for his chosen path in life. In 1881 he was married to a Miss Weld (daughter of Addison Weld) of this city, one child—a daughter—resulting from the union. These survive to sorrow for and miss a fond husband and father. Interment was made at Rochester.

SOME ORDERS IN HAND FOR THE CHURCH TRAY.—Mr. John Cabot, of this city, is kept pretty busy getting out orders for the Church purifier trays. Two of the largest contracts now on his books are the following: Trays for the 20 ft. by 20 ft. purifiers of the Syracuse (N. Y.) Gas Light Company; and 40,000 square feet for the purifying boxes of the Consolidated (N. Y.) Gas Light Company. This last quantity is equivalent to supplying three sets of the new purifiers at the 14th, 21st and 44th street stations of New York city's huge gas corporation.

GAS COAL FOR THE QUAKER CITY WORKS.—Director of Public Works Wagner (Phila. Pa.) has decided upon the following allotment for coal supplies to the local gas works during the fiscal year: Penn Company, 125,000 tons; Westmoreland Company, 125,000 tons; Manor, 25,000 tons; Aurora, 30,000 tons; Flemington and Gaston, 25,000 tons; Despard, 20,000 tons; Earl of Hopetoun canal, 6,000 tons.

CHANGE IN THE MASSACHUSETTS GAS COMMISSION.—Mr. A. B. Coffin, of Winchester, has been selected to fill the vacancy in the Massachusetts Gas Commission caused by the resignation of Mr. Starkes Whiton. The latter gentleman has accepted a place on the State Savings Bank Commission. The new appointee is a lawyer of excellent repute. Mr. Whiton's decision was received with regret, but the general impression is that his new berth will be more congenial to him, since the ramifications of banking are to his mind as an open book is to his vision.

BIRDS OF PASSAGE.—Perhaps the gas men are in mortal terror over the future security of their position as artificial light suppliers, but the idea hardly seems reconcilable with the fact that they can find time—and banker's drafts—to go off in such numbers to "foreign parts." Benson, Stein, and others have but unpacked their trunks, when along comes another list of those who have only just packed theirs. Mr. M. S. Greenough, of the Boston (Mass.) Gas Light Company, is ere this safely landed on the other side; Mr. John McDougall, of the Hornellsville (N. Y.) Company, sailed, in the Servia, on May 21; Mr. Jas. Somerville, of the Indianapolis (Ind.) Company, was snugly ensconced in the Wyoming, on May 19; while Mr. J. H. Morley, of the Cleveland (Ohio) Company, will take flight on June 18. Perhaps the Jubilee Meeting of the British Gas Institute can hereafter be characterized as the occasion of the "Yankee invasion," for we presume that our "birds of passage" will find it perfectly convenient to be in Glasgow, Scotland, on the 28th inst. May they all have a merry time, and a prosperous voyage home.

SOMETHING MORE ABOUT GRAND RAPIDS, MICH.—In order to complete our previous mention of gas extensions at Grand Rapids we note that the Company will lay a new 20-inch leading main from the works to the business portion of the city; also, a considerable stretch of 10 and 12-inch pipes. The holder is to be inclosed in a brick building, covered

with an iron trussed roof. The Kerr Murray Manufacturing Company will erect the holder, the roof to house being also included in the contract.

AGENCY FOR THE BRECKENRIDGE CANNEL.—Messrs. Perkins & Co., 228 Produce Exchange, this city, under whose prompt and business-like direction the famous Breckenridge cannell has been distributed so largely throughout the United States and Canada, have had their agency in this respect extended to cover Great Britain, the Continent and South America. We congratulate them.

THE ARKANSAS CITY (ARK.) GAS PLANT.—Having previously mentioned the fact that a gas company to operate in Arkansas City had been organized, we may now state that Colonel C. K. Holliday, of Topeka, Kansas, who was the prime mover in the new enterprise, has awarded the contract for furnishing the iron work for a complete new six-inch coal gas plant in that place to the Kerr Murray Manufacturing Company, of Fort Wayne, Ind. The contract embraces an iron trussed roof for retort house, bench castings, exhauster, horizontal pipe condenser, a Chollar patent scrubber, purifiers—8 ft. square—station meter, a 50 ft. by 18 ft. single-lift holder and a steam boiler. The construction of the Arkansas City plant will begin at once, and be under the supervision of Mr. B. E. Chollar, so well known from his connection with the Excelsior Gas and Coke Company, Topeka, Kansas.

WE MIGHT AS WELL FINISH IT.—Mention of the above puts us in mind that the Kerr Murray Company is enjoying a very prosperous season. We have already noted what its proprietors are doing at Grand Rapids and Arkansas City, but in addition to those contracts they have agreed to put up a telescopic holder—68 feet 6 inches diameter in 20-ft. lifts—at La Crosse, Wis.; also, a 40 ft. by 16 ft. single-lift holder for the Santa Fe (New Mexico) Company. Verily, even if Brother Cressler does not go to Europe this summer, he will nevertheless have occasion to do some tall traveling.

ANNUAL ELECTION, EAST ALBANY, N. Y.—At the annual meeting of the East Albany Gas Light Company Messrs. Frank Chamberlain, Jas. H. Miller, Paul S. Merrifield, F. A. Sabbaton and P. A. Sabbaton were chosen Directors. Organization resulted in the selection of F. A. Sabbaton as President and Treasurer, P. A. Sabbaton being designated as Secretary and Superintendent.

AS VIEWED BY A MACON (GA.) NEWSMAN.—Some of the "gas grabbers" are looking with envious eyes at the territory so honestly covered and thoroughly supplied with gas from Brother Boardman's model Macon gas plant. The editor of the *Macon Daily Telegraph*—a *rara avis* among newspaper men is he—however, has been looking over the situation, and, to obtain a fair line on the matter, has calculated the percentage of reduction made by 71 gas companies in the country during the past 15 years. He thus sums up his conclusions. Premising the judgment with the remark that only two of the 71 (Yonkers, N. Y., 69 per cent., and Seattle, Wash. Ter., 75 per cent.) have been more liberal than Macon (62½ per cent.) during the period reviewed, he concludes: "This is interesting just now, as it goes to prove that the local company, never having had competition, has dealt more liberally than those in cities where competition did exist. The Macon reductions have been made under the present management, and it is only fair to infer that they will continue to be made"—right again, Mr. Editor, or we do not know Brother Boardman—"as fast as the cost of making the gas and distributing it through our wide streets and to our sparse population will admit. Let us do justice though the heavens fall." Amen!

HOLYOKE (MASS.) TO HAVE CHEAPER GAS.—The Holyoke gas plant is owned by the proprietors of the Holyoke Water Power Company who claim to have invested \$100,000 for the purpose of furnishing gas to the inhabitants of that town. They have been pretty liberal in the management of the gaseous branch of their somewhat close corporation, and evidently mean to keep up with the times, for they now send us word that hereafter the gross price is to be adjusted at \$2 per thousand. Prompt payment (within 5 days from presentation of accounts) secures a rebate of 5 per cent. to ordinary consumers; 12½ per cent. being allowed in case the consumption amounts to a certain fixed quantity. The prior gross rate was \$2.25, the discounts having been similar to those stated. Last year the total output was 35½ millions cubic feet, and the average consumption per user is returned at 36,632 cubic feet, which will be noted as much above the general run. The plant seems to be well managed, although the main system might be profitably overhauled, for the leakage or unaccounted-for gas account is returned at somewhat in excess of 15 per cent.

CONSOLIDATED COMPANY (N. Y.) EXTENSIONS.—The Consolidated folks evidently mean that Chief Engineer Bradley shall put in a good portion of his time this summer in the Metropolis. The plant betterment arranged for is on a stupendous scale, since, in addition to the contracts given out as previously announced in these columns, we may add that the Continental Iron Works proprietors are to put up a mammoth holder on the Company's ground located between 15th and 16th streets on Avenue C. The ground bottom is quite soggy at this point, and in consequence the tank is to be built of steel plates—in tub fashion—to rest on a foundation of piles and concrete. The top of tank will, when in duty, be perhaps 32 feet above the ground level. The dimensions of holder are as follows: Outer section, 190 ft. diameter; diameter of tank, 193 ft.; depth of tank, 42 ft. 6 in.; height of sections (holder to be in three lifts) 40 ft. 9 in. These give storage capacity of 3¼ millions cu. ft. The new purifying house at the 44th street station is to be a really handsome structure, and is to have a total dimension of 120 ft. by 67 ft. Messrs. Moran & Armstrong are to put up the building, and Mr. Jas. R. Floyd will equip it with four sets of purifiers, 24 ft. square, to have 20-inch connections. The American Meter Company will put in a handsome station meter calculated to a duty of 2 millions cu. ft. in 24 hours. Mr. Floyd is to furnish the iron work for a new stack of 24 benches at the 14th street station, the Continental Iron Works to supply like material for a new stack of 20 benches at the 21st street station. In the meantime, may we ask, what are the city electricians doing in the way of plant enlargement?

ANNUAL MEETING PORTLAND (ME.) GAS LIGHT COMPANY.—At the annual meeting of this sterling Company (held May 18) the Directors passed a series of resolutions expressive of their regret at the decease of the Hon. Ezra Carter, late a member of the board. Deceased had been connected with the Company for 28 years. President Daveis read the annual report, which showed that the consumption of gas in the twelvemonth was, in round numbers, 49 millions cu. ft., as against 52 millions in the preceding year. The falling off is traced to the fact that the public lighting of the city is in the hands of the electricians. On the 1st of May, '86, but 10 lamps were gas lighted, and those were discontinued in a few days. The number of consumers (May 1, '87) was 2,805; May 1, '86, 2,791, or a gain of 14 for the twelvemonth. Coal used in year, 4,696 tons; oil, 25,064 gallons (67½ tons). These materials yielded about 53 million cubic feet of gas. The gas averaged (mean of three daily observations) 18.7 candle power. Coke sold, 99,483 bush.; tar sold, 257 bbls. The main system was increased by 0.35 of a mile. Enlargement of boiler house, including new roof to structure, the placing of a new boiler, and a new brick stable building, incurred an expenditure of \$3,100. It was expected that 8 benches of retorts would have to be renewed in the present year. The usual dividend payments were made, and \$4,000 was carried over to the renewal and insurance fund. The city of Portland owns 1,700 shares in the capital stock (7,000 shares being the total), and the death of Mr. Carter was seized upon by the authorities as a pretext for allowing them a representative in the board, which consists of six members. When the election for Directors was entered upon Mr. Herbert G. Briggs, acting for the city, voted the city's holding in favor of his selection as a Director. Mr. Briggs, however, secured no additional votes, and the tellers reported that Messrs. E. H. Daveis, C. B. Merrill, W. W. Thomas, Jr., W. H. Moulton, T. Cummings, and F. N. Dow had been chosen. Mr. Briggs, in order to attain the coveted seat, needed just 714 more votes than he secured. At the organization meeting Mr. Daveis was chosen President and Mr. Rolfe Treasurer.

AN ENGLISH HOLDER FOR THE TORONTO (CAN.) WORKS.—Messrs. C. & W. Walker, London, England, are to build the new holder at Toronto, they to complete the task by Nov. 1. It is to be in two lifts, of 35 ft. each. The diameter of first section is to be 150 ft.; that of the second, 148 ft. 6 in. This gives a capacity of about 1,200,000 cu. ft. A leading main (20-inch) has been put down between the works and the new holder two miles distant from the former. The restrictions imposed by the city authorities in regard to the issue of additional capital stock by the Company have been accepted by the former, although we think some of the conditions are onerous. At any rate the city has small reason for complaint in the premises, either in regard to the framing of the policy or in respect of the manner or spirit in which it was accepted. The population of Toronto is something like 130,000, and the annual send-out of the Toronto Company (now about 350 millions cu. ft.) increases at the rate of 17 per cent. per annum, while population increase does not exceed 8 per cent. Perhaps the explanation is to be found in the liberal management pursued by Mr. Pearson and associates, who are selling gas at \$1.25, \$1.10, and \$1 per thousand—the latter being paid for gas used for cooking, heating, and power purposes. When all the plant extensions

contemplated have been finished, the sum of \$500,000 will have been paid out by the Toronto gas men; but we must say we are sorry some one of our American manufacturers did not succeed in obtaining the award made to the Messrs. Walker, of England. However, if they are willing to be greatly underbid by foreign capital, perhaps our regret is misplaced.

AN IMPORTANT LEGAL DEFINITION.—We are indebted to the President of the Cincinnati (O.) Company for a copy of the decision handed down by the Circuit Court in the matter of a demurrer of Chas. J. Steinau against an injunction, previously issued by Judge Maxwell, at the instance of the Cincinnati Gas Light and Coke Company, restraining him from breaking a contract under which he had agreed (on March 16, 1886) to light his store, known as the "Palace," for a term of ten years with gas exclusively. Steinau, a few weeks ago, determined to employ incandescent lamps on his premises, whereupon the Company, insisting upon the fulfilment of the contract, prayed for an injunction, which prayer was heard. The Circuit Court sustains Judge Maxwell at all points. Rather than publish a condensed report of the findings in this issue we make the above mention now, and shall reproduce the matter *in extenso* in our mid-month edition. The General is great on earth-works, and also can "tell a hawk from a handsaw" in the matter of contracts, franchises, etc.

WRITING of the General and Cincinnati puts us in mind of the fact that the Cincinnati *Telegram*, which is particularly rabid on the subject of gas in general, and Hickenlooper in particular, has had a change of (we had almost said life) color. Its hue, formerly gory (albeit rather watery, or of the *vin ordinaire* shade) has merged into a dull, commonplace white. Under the earlier fashion it suggested one of ex-Senator Thurman's cast-off bandanas; but its present guise calls to mind the remnants of what was once a powerful factor—Senator Sherman's once ensanguined shirt.

ANOTHER HORROR AT THE MANKATO (MINN.) GAS WORKS.—A fortnight ago we were obliged to state that Mr. O. C. McCurdy, Secretary of the Mankato Gas Company, had lost his life from accidentally inhaling gas that had made its escape in the purifying room of the plant. We have now to supplement that horror with the announcement that Mr. J. A. Presley, Jr., Superintendent of the works, met his fate at that place in a precisely similar manner. The last victim lived five days after discovery.

ERRATIC INCANDESCENT LAMPS.—Detroit, Mich., reports that the incandescent lamps in that city frequently and unexplainably explode. Among other instances we may cite those at the People's Savings Bank and the Antisdell House. The Bank folks have been treated twice to these capers, the last illustration causing serious wounds to a hand of one of the accountants. "Dutton" was quite right in his conclusion anent certain inferences drawn on a "page."

THE CONTRACT AWARDED.—Work on the new purifying, engine and meter house for the Chattanooga Gas Light Company is under way. The building is to be 118 ft. by 63 ft.

SOLD.—The Columbus (Miss.) gas works, sold on the 17th of May, were nominally purchased by Mr. J. R. Ryan. He secured them cheap—\$23,500.

TYLER, TEXAS.—Propositions for the establishment of a gas plant at Tyler, Texas, will be opened and considered (to-morrow) by the Gas Committee of the local City Council.

BUSY MANUFACTURERS.—During a recent visit to Philadelphia we were shown through the shops of the Messrs. Wilbraham Bros., by the elder Mr. Wilbraham. Over 20 tons of manufactured iron, in the shape of Baker blowers, pumps, engines and an exhauster were to be sent away on the following day, one of the shipments being intended for Salt Lake City.

BUYING OUT THE UTICA (N. Y.) COMPANY.—In our last we noted that the Equitable Company was about to operate the charter obtained for the city of Utica. They have since succeeded in purchasing three-fourths of the stock of the old Company, paying therefor in the neighborhood of \$125 per share, hence the other charter will be pigeonholed. Having secured control, the former directors of the Utica Electric and Gas Company stepped down and out. They were replaced by the following board: Messrs. R. M. C. Graham, Henry Keene, H. Graham, C. D. Harrison, John Fox, J. D. Crimmins, J. P. Miller, A. W. P. Kramer, and E. J. Enfer. President, R. M. C. Graham; Vice-Pres. and Treas.,

H. Keene; Secy., H. Graham; Supt. A. W. P. Cramer. It is understood that a new holder will be erected, and that the present electric light plant will be duplicated. The old Utica Company was chartered in 1848, and was really the creation of the late Mr. H. H. Fish.

NEW WORKS.—We understand that the Atlantic City (N. J.) Gas and Water Works Company is now constructing a new plant at that point, the former rattle trap collection to be handed over to the junkman when the job is finished. The capacity of the apparatus is placed at 250,000 cu. ft. per diem. The Grainger system was chosen.

ELECTION OF DIRECTORS, MUTUAL (N. Y.) COMPANY.—At the annual election of the Mutual Gas Light Company, held May 17, the following Directors were chosen: Messrs. J. P. Kennedy, C. Vanderbilt, G. J. Forrest, J. R. Ford, R. L. Crawford, R. M. Galloway, A. Leary, C. H. Kerner, J. S. Stout, J. Harker, E. S. T. Kennedy, W. K. Vanderbilt, S. Thorne, L. de Bebian, H. Schubart and G. W. Hall.

ANNUAL ELECTION, MONTCLAIR (N. J.) GAS AND WATER COMPANY.—The following were chosen to manage the affairs of this Company for the ensuing year: President, Dr. Love; Secretary, Eugene Vanderpool; Treas., W. H. Baldwin; Supt. Cansbrook was reappointed for another year. The Directors are Messrs. Dodd, Love, Vanderpool, Langstroth, Plum, M. N. Dodd, and Van Vleck.

THE GATE CITY COMPANY.—When W. E. Lawton vanished from New York city he left much debt to remind many of his absence. He was to all intents and purposes the manager of the Gate City Gas Light Company, of Atlanta, Ga., and the stockholders thereof mourned his absence and their loss. However, W. Elliot, who was made temporary receiver of its property, has managed to straighten out matters a bit, and has in consequence been made permanent receiver. He claims that the business is bringing in a profit (over working expenses) of \$12,000 a year; to which we will add that if Brother Helme were out of the way the profit would be something more.

GOOD NEWS.—It is with extreme gratification we say to the many friends of the genial and popular Mr. Chas. W. Isbell, Secretary of the Smith & Sayre Manufacturing Company, that that gentleman is rapidly recovering from the severe illness which has kept him a prisoner during the last month or so.

A LINE FROM LAWRENCE, MASS.—When the electricians descended upon the city of Lawrence, they proclaimed that it was all up with the local gas men, but prophets are said to have no standing in their home circles, and the Lawrence dispensers of dynamic lightnings appear to be at present in that period which the late Mr. Longfellow characterized as the part in life "into which some rain must fall." Wet or dry, however, the Lawrence Gas Company (or the leading stockholders thereof) have purchased a controlling interest in the local Brush Company, and 'tis quite likely that the local Edison branch, which now performs the major, if not the entire, part of the public lighting of the city, will soon seek refuge in the Gas Company's haven. Neither of the electric lighting enterprises proved a profitable venture for their respective original controllers, hence we presume the willingness to give up the separate trust. The stockholders who now control the Brush branch have selected the following officers: President, J. R. Simpson; Sec. and Treas., C. J. R. Humphreys; Directors: J. R. Simpson, J. Fallon, Geo. D. Cabot, W. Oswald, G. Davis, R. F. McCartney and C. J. R. Humphreys.

DOWN AGAIN AT NORTH ADAMS, MASS.—Brother Richardson, the man at the helm in North Adams, has decided to reduce the gas rate in that city to \$2 per thousand from and after first prox. Prevailing rate, \$2.25. In half a decade the price has been cut just 33½ per cent.

MADE INSPECTOR.—The appointment made by Mayor Roche, under which Col. Quirk was named as Gas Inspector for the city of Chicago, has been confirmed by the City Council. The Col. qualified in the sum of \$10,000.

NORTHAMPTON (MASS.) GAS DOINGS.—The annual meeting of the Northampton Gas Company was held on May 25. The following officers were elected: President, M. M. French; Treasurer, Geo. P. Dickinson; Superintendent, old reliable, D. W. Crafts; Directors, Messrs. John F. Starr, Geo. W. Hubbard, M. M. French, G. P. Dickinson, and D. W. Crafts. The annual report was quite satisfactory. It was decided to make some important main extensions.

THE SANFORD (FLA.) FOLKS AGAIN AT WORK.—The new plant installed at the Sanford gas works is now in successful operation.

NEW COMPANY.—Mr. A. J. Hoopdale intends to secure a gas franchise for Union City, Tenn.



A. M. CALLENDER & CO.,

PROPRIETORS.

Editor—JOS. R. THOMAS, C.E.
Asst. Editor—T. J. CUNNINGHAM.
Manager—C. E. SANDERSON.

PUBLISHED ON THE 2ND AND 16TH OF EACH MONTH
At No. 42 Pine Street, New York.

This is a recognized official organ of—
LIGHT, HEAT, STEAM, WATER-SUPPLY,
VENTILATION, SANITARY IMPROVEMENT,
AND GENERAL SCIENCE.

TERMS

SUBSCRIPTION—Three Dollars per annum, in advance.

AGENTS

NEW YORK—AMERICAN NEWS CO. 39 and 41 Chambers St.
BOSTON—S. M. PETTENGILL & Co., 6 State Street.
PHILADELPHIA—PRATT & Co., Corner 9th and Arch Streets.
England—C. W. HASTINGS, 22 Buckingham St., London, W C
Germany—B. WESTERMANN & Co., of New York

THURSDAY, JUNE 2, 1887.

The Market for Gas Securities.

Consolidated moved up sharply during the fortnight on the understanding that the dividend rate would be increased, but while rumor was right as to the main point, it was wrong in regard to the exact sum. A dividend of 2 per cent. was declared by the executive, which will be noted as an increase of one-half per cent. over the semi-annual payments made since the passage of the \$1.25 gas rate law. The bill to relieve the suburban companies, or those in the annexed district, whereby a higher rate for gas may be charged in that section, passed both branches of the Legislature, but at time of writing we are unaware of the Governor's action on the measure. Brooklyn shares are stronger. The Williamsburgh Company has declared a 3 per cent. dividend. The Syracuse (N. Y.) Company has increased its stock to \$500,000; and the Mansfield (Ohio) Company's capital has been raised to \$90,000. Shares in the New Orleans (La.) Company have declined considerably in quoted value, and are now offered at 70. At that figure these shares look like a purchase.

Gas Stocks.

Quotations by Geo. W. Close, Broker and Dealer in Gas Stocks.

16 WALL ST., NEW YORK CITY.

JUNE 2.

All communications will receive particular attention.
The following quotations are based on the par value of \$100 per share.

	Capital.	Par.	Bid	Asked
Consolidated.....	\$35,430,000	100	87	—
Central.....	440,000	50	30	—
“ Scrip.....	220,000	—	47	57
Equitable.....	2,000,000	100	126	130
“ Bonds.....	1,000,000	—	113	115
Harlem, Bonds.....	170,000	—	—	—

Metropolitan, Bonds....	658,000	—	110	113
Mutual.....	3,500,000	100	101	103
“ Bonds.....	1,500,000	1000	101	—
Municipal, Bonds.....	750,000	—	—	—
Northern.....	125,000	50	30	—
“ Scrip.....	108,000	—	—	—
Yonkers.....	—	50	—	80
Richmond Co., S. I....	300,000	50	50	—
“ Bonds.....	12,000	—	—	—
Gas Co's of Brooklyn.				
Brooklyn.....	2,000,000	25	104	106
Citizens.....	1,200,000	20	55	57
“ S. F. Bonds....	320,000	1000	—	103
Fulton Municipal.....	3,000,000	100	139	141
“ Bonds....	300,000	—	—	106
Peoples.....	1,000,000	10	57	60
“ Bonds (5's).....	368,000	—	97	—
“ “ (6's).....	94,000	—	100	—
Metropolitan.....	1,000,000	100	84	86
Nassau.....	1,000,000	25	104	106
“ Cts.....	700,000	1000	100	—
Williamsburgh.....	1,000,000	50	125	130
“ Bonds....	1,000,000	—	111	—
Out of Town Gas Companies.				
Boston (Mass.) Gas Co.	2,500,000	500	193	200
Buffalo Mutual, N. Y..	750,000	100	90	95
“ Bonds....	200,000	1000	95	100
Citizens, Newark.....	1,000,000	50	—	—
“ “ Bonds.	45,000	—	—	—
Chicago Gas Co., Ills..	5,000,000	25	142	145
Peoples G. L. & C. Co.,				
Chicago, Ills.....	3,000,000	—	29	31
Cincinnati G. & C. Co..	6,000,000	100	184	185
Consolidated, Balt.....	6,000,000	100	73½	75
“ Bonds....	3,600,000	—	107	107½
Chesapeake, Balt.....	1,500,000	100	95	100
“	1,000,000	—	100	102
Consumers Toronto....	1,000,000	50	192	—
Central, S. F., Cal.....	—	—	86	100
Capital, Sacramento, Cal.	—	—	56	58
Hartford, Conn.....	750,000	25	140	142
Jersey City.....	750,000	20	168	—
Laclede, St. Louis, Mo.	1,600,000	100	125	—
Louisville, Ky.....	2,570,000	50	130	132
Little Falls, N. Y.....	50,000	100	95	100
“ Bonds	25,000	—	100	103
Montreal, Canada.....	2,000,000	100	209	215
New Haven, Conn.....	—	25	193	197
Oakland, Cal.....	—	—	36½	—
Peoples, Jersey City... ..	—	—	25	30
“ “ Bonds..	—	—	—	—
Paterson, N. J.....	—	25	90	—
Rochester, N. Y.....	—	50	75	80
St. Louis, Missouri.....	600,000	50	—	—
San Francisco Gas Co.				
San Francisco, Cal....	10,000,000	100	59¾	60
Memphis (Tenn.) Gas... ..	750,000	100	—	—
“ Bonds.	240,000	100	103	—
Washington, D. C.....	2,000,000	20	210	—
Wilmington, Del.....	—	50	200	208
Havana (Cuba) Gas Co.	3,000,000	100	18	20
“ Bonds.....	550,000	—	102	—

Advertisers Index.

GAS ENGINEERS.		Page
Jos. R. Thomas, New York City		364
Wm. Henry White, New York City.....		364
Wm. Mooney, New York City.....		364
William Gardner, Pittsburgh, Pa.....		364
GAS WORKS APPARATUS AND CONSTRUCTION.		
James R. Floyd, New York City		367
T. F. Rowland, Greenpoint, L. I.....		367
Delly & Fowler, Phila., Pa.....		367
Kerr Murray Mfg. Co., Fort Wayne, Ind.....		366
Stacey Mfg. Co., Cincinnati, Ohio.....		367
Bartlett, Hayward & Co., Baltimore, Md.....		356
Morris, Tasker & Co., Limited, Phila., Pa.....		366
Davis & Farnum Mfg. Co., Waltham, Mass.....		358
R. D. Wood & Co., Phila., Pa.....		366
Southwark Foundry and Machine Co., Philadelphia, Pa.....		366
Bouton Foundry Co., Chicago, Ills.....		355

PROCESSES.

National Gas Light and Fuel Co., Chicago Ills	357
GAS AND WATER PIPES.	
Gloucester Iron Works, Phila., Pa.....	364
Mellert Foundry and Machine Co., Reading, Pa.....	364
Cincinnati and Newport Iron and Pipe Co., Newport, Ky... ..	364
Ohio Pipe Co., Columbus, Ohio.....	364
Pancoast & Rogers, New York City.....	364
M. J. Drummond, New York City	364
Wells Rustless Iron Co., New York City.....	363

GAS ENGINES.

Schleicher, Schumm & Co., Phila., Pa	340
Clerk Gas Engine Co., Phila., Pa.....	359

RETORTS AND FIRE BRICK.

J. H. Gautier & Co., Jersey City, N. J.....	362
B. Kreischer & Sons, New York City	362
Adam Weber, New York City	362
Laclede Fire Brick Works, St. Louis, Mo	362
Brooklyn Retort and Fire Brick Works, Brooklyn, N. Y.	362
Borgner & O'Brien, Phila., Pa	362
James Gardner, Jr., Pittsburgh, Pa.....	362
Henry Maurer & Son, New York city.....	362
Chicago Retort and Fire Brick Works, Chicago, Ills.. ..	362
Baltimore Retort and Fire Brick Co., Baltimore.....	362
Oakhill Gas Retort and Fire Brick Co., St. Louis, Mo.....	362
Evens & Howard, St. Louis, Mo.....	363
Cincinnati Gas Retort and Fire Brick Works, Cincinnati, O.	363
Emil Lenz, New York City.....	363

SCRUBBERS AND CONDENSERS.

G. Shepard Page, New York City.....	365
-------------------------------------	-----

REGENERATIVE FURNACES.

Bartlett, Hayward & Co., Baltimore, Md.....	356
Fred. Bredel, New York City.....	363

GAS GOVERNORS.

T. C. Hopper, Phila., Pa	360
--------------------------------	-----

CEMENTS.

C. L. Gerould, Manchester, N. H.....	362
--------------------------------------	-----

GAS ENRICHERS.

Standard Oil Co., Cleveland, Ohio.....	368
--	-----

GAS METERS.

Harris, Griffin & Co., Phila., Pa.....	370
American Meter Co., New York and Philadelphia	371
The Goodwin Gas Stove and Meter Co., Philadelphia, Pa... ..	371
Helme & McIlhenny, Phila., Pa.....	371
D. McDonald & Co., Albany, N. Y.....	371
Nathaniel Tufts, Boston, Mass.....	370

EXHAUSTERS.

P. H. & F. M. Roots, Connersville, Ind	358
Smith & Sayre Manufacturing Co., New York City	367
Wilbraham Bros., Philadelphia, Pa.....	359
Connelly & Co., New York City.....	359

GAS COALS.

Penn Gas Coal Co., Phila., Pa.....	369
Perkins & Co., New York City	368
Newburgh Orrel Coal Co., Baltimore Md	369
Despard Coal Co., Baltimore, Md.....	369
Chesapeake and Ohio R.R. Coal Agency, N. Y. City	369
Westmoreland Coal Company, Phila., Pa	369
Monongahela & Peters Creek Gas Coal Co., Pittsburgh, Pa.. ..	369

CANNEL COALS.

Perkins & Co., New York City.....	368
J. & W. Wood, New York City.....	368

VALVES.

Ludlow Valve Manufacturing Co., Troy, N. Y.	360
John McLean, New York City	360
Chapman Valve Manufacturing Co., Boston, Mass.....	360

ENGINES AND BOILERS.

Jarvis Engineering Co., Boston, Mass.....	359
---	-----

PURIFYING MATERIAL.

S. H. Douglas, Ann Arbor, Mich.....	363
-------------------------------------	-----

GAS LAMPS.

The Siemens-Lungren Co., Philadelphia, Pa.....	365
G. Shepard Page, New York City.....	364
Alho-Carbon Light Co., Newark, N. J.....	357
Standard Gas Lamp Co., Phila., Pa.....	363

PURIFIER SCREENS.

John Cabot, New York City.....	331
Geo. A. Mills, Baltimore, Md.....	363

GAS STOVES.

American Meter Co., New York and Philadelphia... ..	361
The Goodwin Gas Stove and Meter Co., Phila. Pa.	372

STREET LAMPS.

J. G. Miner, Morrisania, New York City.....	324
Bartlett Street Lamp Mfg Co., New York City.....	360

BURNERS.

G. Gofrorer, Phila., Pa.....	363
------------------------------	-----

STEAM BLOWER FOR BURNING BREESE.
H. E. Parson, New York City..... 332

GASHOLDER TANKS.
W. C. Whyto, New York City..... 363

GAS FIXTURES.
Mitchell, Vanco & Co., New York City..... 360

COKE CRUSHER.
C. M. Koffler, Columbus, Ind.... 369

GAS BAGS.
Peerless Manuf'g Co., New York City..... 359

BOOKS, ETC.
English Journal of Gas Lighting..... 355
Gas as a Source of Light, Heat and Power..... 360
Goodwin's Directory of Gas Light Companies..... 368
King's Treatise..... 370
Scientific Books..... 370
Management of Small Gas Works..... 364
Nowbigging's Gas Manager's Handbook..... 370
Gas vs. Electricity..... 367

WANTED.
Bound Copies of the English "Journal of Gas Lighting," for years 1884-5-6. Also, Bound Copies of the "American Gas Light Journal," for years 1884-5-6. "King's Treatise" complete.
670-tf EMERSON McMILLIN, Columbus, Ohio.

FOR SALE,
Ten No. 2 Siemens Regenerative Gas Lamps,
With Factory Fixtures and Reflectors complete and in order.
Only used three or four months. Will be sold cheap.
DANVILLE NAIL AND MFG. CO.,
Danville, Pa.

FOR SALE,
Two Sinuous Friction Condensers,
Each 1 ft. 3 in. wide by 11 ft. 3 in. long, and 18 ft. high, of sufficient capacity for 225,000 cu. ft. per day. Apply to
665-12 PETER COFFEY, Supt Gas Co., Peoria, Ill.

FOR SALE.
The St. Paul (Minn.) Gas Light Company desires to enlarge its works, and offers for sale the following apparatus, which is in perfect condition:
Six Benches of 6's.
Four Benches of 5's.
One Scrubber,
4 ft. 6 in. by 4 ft. 6 in. by 15 ft.
One 10-inch Exhauster.
Four 8 by 12 Purifiers,
10-inch connections.
Two 8-Horse Power Boilers.
One 4-Horse Power Engine.
One Coke Crusher.
THE ST. PAUL GAS LIGHT CO.,
670-4t E. I. FROST, Sec. & Treas.

ALBO-CARBON FIXTURES FOR SALE.
Three 12-Burner, Two 8-Burner, and Fourteen 6-Burner Clusters.
All in good order, having been used but six months. Will be sold cheap. For particulars communicate with
NORTH ATTLEBORO GAS LT. CO.,
North Attleboro Mass.

ENGLISH
"Journal of Gas Lighting."
Issued weekly. New volume commences Jan. 1, 1887. Price, \$7 per annum. Subscriptions taken by
CHARLES NETTLETON, Agent for U. S.
No. 115 BROADWAY, N. Y. CITY.

ENGAGEMENT DESIRED
As Superintendent of Small Gas Works
or Assistant in a Large Works.
Best of references given. Address
671-1 "C. J.," care this Journal.

Superintendent's Position Desired,
By a young man of several years experience in the manufacture and distribution of coal gas. Best of references given.
671-1 Address "P. B.," care this Office.

Superintendent's Position Desired
By a practical man of twenty-five years' experience in the manufacture and distribution of coal and water gas. Satisfactory references given. Address
646-tf "ENGINEER," care this Office.

Bouton Foundry Co.,
FOUNDERS AND MACHINISTS,
CHICAGO, ILL.
Gas Works Apparatus,
PURIFIERS, CONDENSERS,
Bench Work,
SPECIALS, LAMP POSTS,
SCRUBBERS,
Iron Roofs and Floors.
Plans and Estimates furnished for new works or extensions of old works.

To All Whom It May Concern!

The SIEMENS-LUNGREN COMPANY hereby warns the public against the use of various infringing Regenerative Gas Lamps which are offered for sale. This Company has heretofore delayed bringing suit to enjoin the manufacture or importation of such infringing lamps, solely because of the practical worthlessness of the infringing devices; and although, in each instance, they infringe some one or more of the various patents owned or controlled by this Company, they have fallen into disuse sooner than any suit could be brought to a hearing. As, however, the introduction of these infringing lamps has tended to discredit the practicability of our Company's system of regenerative gas lighting, we have instructed our Attorneys, Messrs. Geo. Harding, C. S. Whitman, and Silas W. Pettit, to give notice that legal proceedings will in future be taken against all such infringers.

THE SIEMENS-LUNGREN CO., 21st St. & Washington Av., Phila., Pa.

To All Whom It May Concern.

TAKE NOTICE!

All parties making, selling, or using REGENERATIVE GAS LAMPS constructed upon the plan or principle of the Wenham Lamp, as secured to us by Letters Patent of the United States of July 17, 1883, and November 30, 1886, will be held to strict accountability for every violation of the rights so secured to us.

UNITED STATES WENHAM PATENT GAS LIGHT COMPANY.

E. LEB. GARDINER, Secy.
NEW YORK, May, 1887.

JOHN D. CUTTER, President.

BARTLETT, HAYWARD & CO.

Baltimore, Md.

Munich Regenerative Furnace, System Drs. Schilling & Bunte.

Greatest durability; minimum of attention; complete distillation in 3½ hours; 10 to 13 pounds of coke to hundred-weight of coal; no clinker; no carbonic oxide in regenerative flues.

TWO AND THREE-LIFT TELESCOPIC GASHOLDERS,

With Wrought Iron Tanks, constructed above ground, of any magnitude.

Condensers, Scrubbers, Purifiers, Bench Castings, Roofs, Boilers, Etc.

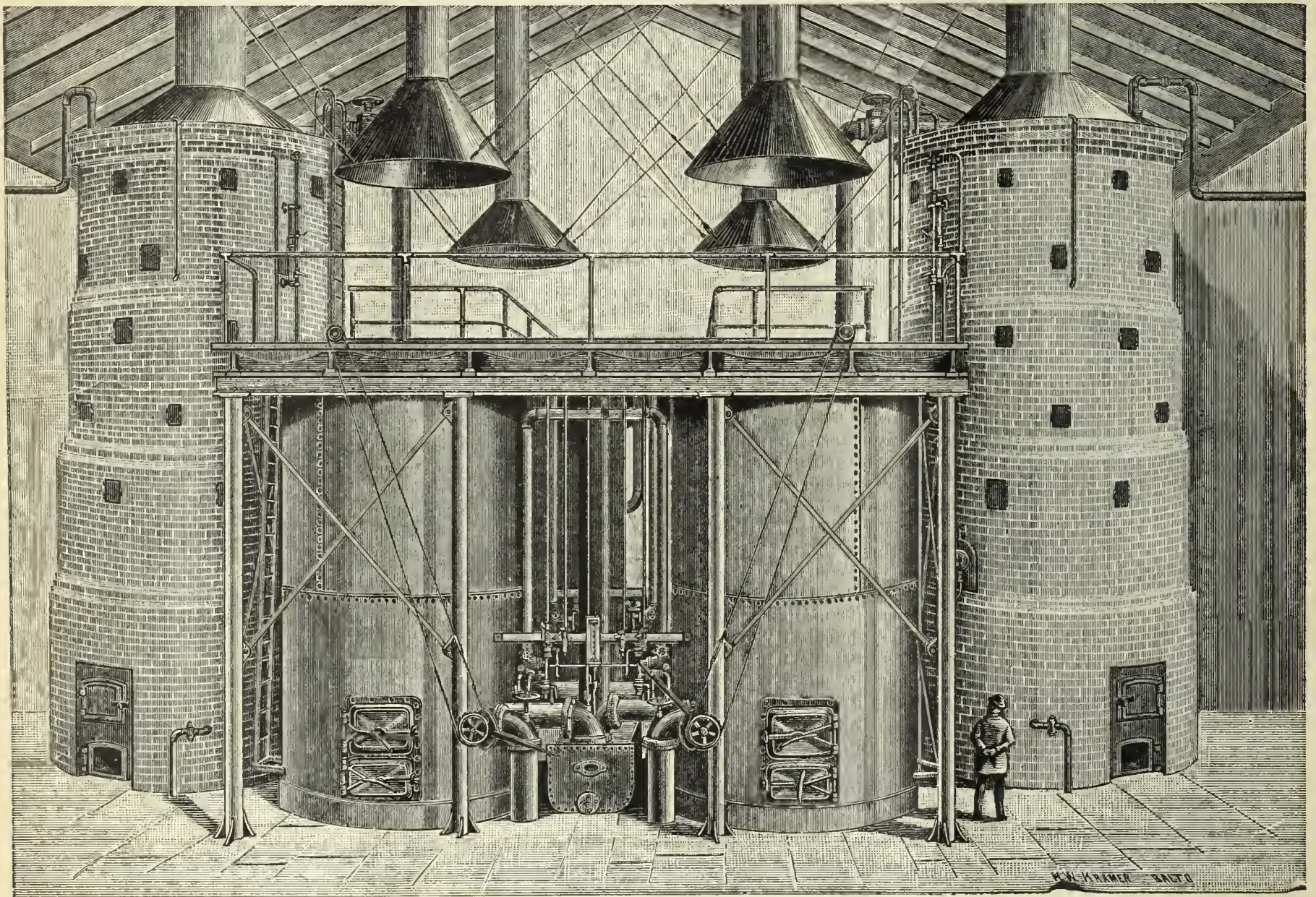

The Wilkinson Water Gas Process.

Introducing the Munich Regenerative Furnace for Coal Gas, we find on the part of many Gas Companies the desire to combine to a greater or less extent an efficient system of making high candle power Water Gas; and with a view of enabling this to be done WITHOUT EXCESSIVE CHARGES FOR PATENT RIGHTS, ETC., we have acquired, by purchase, the exclusive right to construct all the Water Gas Apparatus under the valuable "Wilkinson" Patents.

The results obtained by this Process are far better than those obtained by any other apparatus, especially where an illuminating gas of high candle power or a fuel gas of intense temperature is required.

The Process is uninterrupted, making gas of uniform quality and quantity. Its greatest advantages are maximum production with minimum material and labor, combined with great durability of apparatus.

The Process is in successful operation at the works of the N. Y. Mutual Gas Company, New York; Consolidated Gas Company, Baltimore, Md.; the Hudson County Gas Light Company, of Hoboken, N. J.; and at Rye, N. Y.

We shall be glad to give further detailed information upon application.

BARTLETT, HAYWARD & CO.

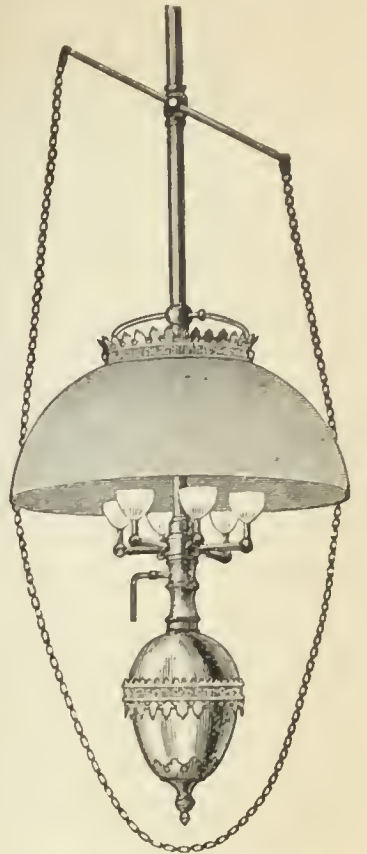
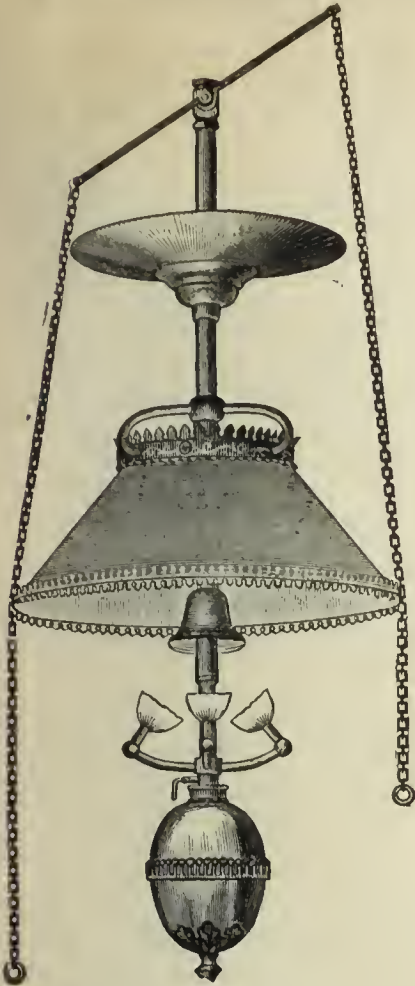

THE ALBO-CARBON LIGHT!

The Perfection of Gas Lighting.

Producing the Highest Illumination yet obtained from Gas, and

EFFECTING A SAVING IN ITS CONSUMPTION.

It has been most effective in

Replacing Electricity,

AFFORDING A

SOFT WHITE LIGHT
of **EXTREME BRILLIANCY & POWER.**

It has been most successful in

Supplanting Kerosene,

Giving Increased Light, Less Heat, and Perfect Safety

WITHOUT ADDITIONAL COST.

NOTICE.—Suits are pending in the United States Circuit Courts in Illinois and Pennsylvania against various parties for infringement of our Letters Patent No. 247,925, dated October 4, 1881, and No. 333,862, dated January 5, 1886. The first of these suits has come up for hearing, and an injunction has been granted therein. The second of said suits has not yet been reached for hearing. All persons are cautioned against manufacturing, selling, or using any apparatus or material which infringes our Patents. We intend to prosecute all parties infringing patents owned by us.

THE ALBO-CARBON LIGHT COMPANY, - - - NEWARK, N. J.,
Sole Manufacturers for the United States.

DURING THE PAST YEAR, THE

NATIONAL GAS LIGHT AND FUEL CO.

218 LA SALLE ST., CHICAGO,

Have Erected Twelve Sets of Water Gas Generating Apparatus under the *Springer Cupola* System. They are as follows:

- Newton Illuminating Company, Newton, Kansas.— Daily capacity, 120,000 cu. ft.
- Wellington Light & Heat Co., Wellington, Kansas.— Daily capacity, 120,000 cu. ft.
- Chippewa Falls, Gas Light Co., Chippewa Falls, Wis.— Daily capacity, 120,000 cu. ft.
- Elkhart Gas Light & Coke Co., Elkhart, Indiana.— Daily capacity, 120,000 cu. ft.
- Madison City Gas Light Company, Madison, Wis.— Daily capacity, 120,000 cu. ft.
- South Bend Gas Light Co., South Bend, Indiana.— Daily capacity, 250,000 cu. ft.
- Sheboygan National Gas Comp'y, Sheboygan, Wis.— Daily capacity, 120,000 cu. ft.
- Salina Gas Light Company, Salina, Kansas.— Daily capacity, 120,000 cu. ft.
- Rathbun Company, Deseronto, Province Ontario.— Daily capacity, 80,000 cu. ft.
- Jefferson City Gas Light Co., Jefferson City, Mo.— Daily capacity, 120,000 cu. ft.
- Mankato Gas Light Company, Mankato, Minnesota.— Daily capacity, 80,000 cu. ft.
- Minneapolis Gas Lt. & Coke Co., Minneapolis, Minn.— Daily capacity, 1,000,000 cu. ft.

1886

1886

EXHAUSTERS.

EXHAUSTERS.

EXHAUSTERS.

THE ROOTS GAS EXHAUSTER.

CINCINNATI, OHIO, March 24, 1887.

P. H. & F. M. Roots, Connersville, Ind.: Gentlemen—I have the honor to say that after the continuous and uninterrupted use of your Exhausters for a period of fifteen years, it affords me pleasure to endorse them in the highest possible terms.

Very respectfully,

A. HICKENLOOPER, Prest. Cincinnati Gas Co.

CINCINNATI GAS LIGHT AND COKE CO., Cincinnati, Ohio, two No. 6 Gas Exhausters, with Engine, for their new works, which, with the two No. 6 Exhausters, without Engines, at their old works, and one No. 3, with Engine for pumping, for their station at Carthage, make five Exhausters in all for this Company.

CHICAGO, ILL., March 24, 1887.

Messrs. P. H. & F. M. Roots, Connersville, Ind.: Dear Sirs—We have two of your No. 6 Exhausters at our works, which have been running for several months, and are giving very good satisfaction. Yours truly,

THEO. FORSTALL, Prest.

THE CHICAGO GAS LIGHT AND COKE CO., Chicago, Ill., two No. 6 Gas Exhausters and Engine combined on same bed-plate.

St. LOUIS, Mo., March 21, 1887.

Messrs. P. H. & F. M. Roots, Connersville, Ind.: Dear Sirs—In 1872 one of your No. 5 Exhausters was placed in these works, and worked satisfactorily. March, 1885, it was replaced by one of your No. 6 Exhausters. The latter has been in almost constant use the past two years, has worked up to all my expectations, and is to-day in apparently as good condition as when first set up. It has not cost one cent for repairs in all that time. I have also had one of your No. 1 Exhausters, with Engine on same bed-

P. H. & F. M. ROOTS, Patentees and Manufacturers, **CONNERSVILLE, IND.**
S. S. TOWNSEND, Gen. Agt., 22 Cortlandt St., N. Y.

plate, fitted with your valves and Huntoon Governor, placed in a small works under my control, and in its operation it seems as near perfection as I ever expect an Exhauster to become. Without in the least disparaging Exhausters of other makes, I may say that your Exhauster may be safely recommended as unsurpassed by any other, to those requiring such machines.

Yours respectfully,

FREDERIC EGNER, Eng. and Supt.

CLEVELAND, OHIO, March 22, 1887.

Messrs. P. H. & F. M. Roots, Connersville, Ind.: Gentlemen—Concerning the Exhauster furnished this Company by you last fall, I can say but little—indeed, much need not be said. It simply does its work perfectly, and in a way that inspires confidence that it will not shirk its duty when one's back is turned. If I wanted another 1,000,000 capacity I should try and duplicate our No. 4.

Very respectfully,

EDWARD LINDSLEY, Eng. and Supt.

PEOPLES GAS LIGHT CO., Cleveland, Ohio, one No. 4 Exhauster and Engine combined on same bed-plate, Pipe Fittings, Gas and Bye-Pass Valves, Governor, etc.

INDIANAPOLIS, IND., March 21, 1887.

P. H. & F. M. Roots, Connersville, Ind.: Gentlemen—The No. 4 Exhauster and Engine which you erected for us last summer has done all you claimed for it, and has given us perfect satisfaction. Yours very truly,

JAS. SOMERVILLE, Eng. and Supt.

INDIANAPOLIS GAS LIGHT CO., Indianapolis, Ind., one No. 4 Gas Exhauster and Engine combined on same bed-plate, Pipe Fittings, Gas and Bye-Pass Valves, etc. This Exhauster has a capacity of 1,000,000 cu. ft.

COOKE & CO., Selling Agts., 22 Cortlandt St., N. Y.

F. J. DAVIS & J. R. FARNUM,

TRUSTEES AND AGENTS FOR THE

SINUOUS FRICTION CONDENSER.

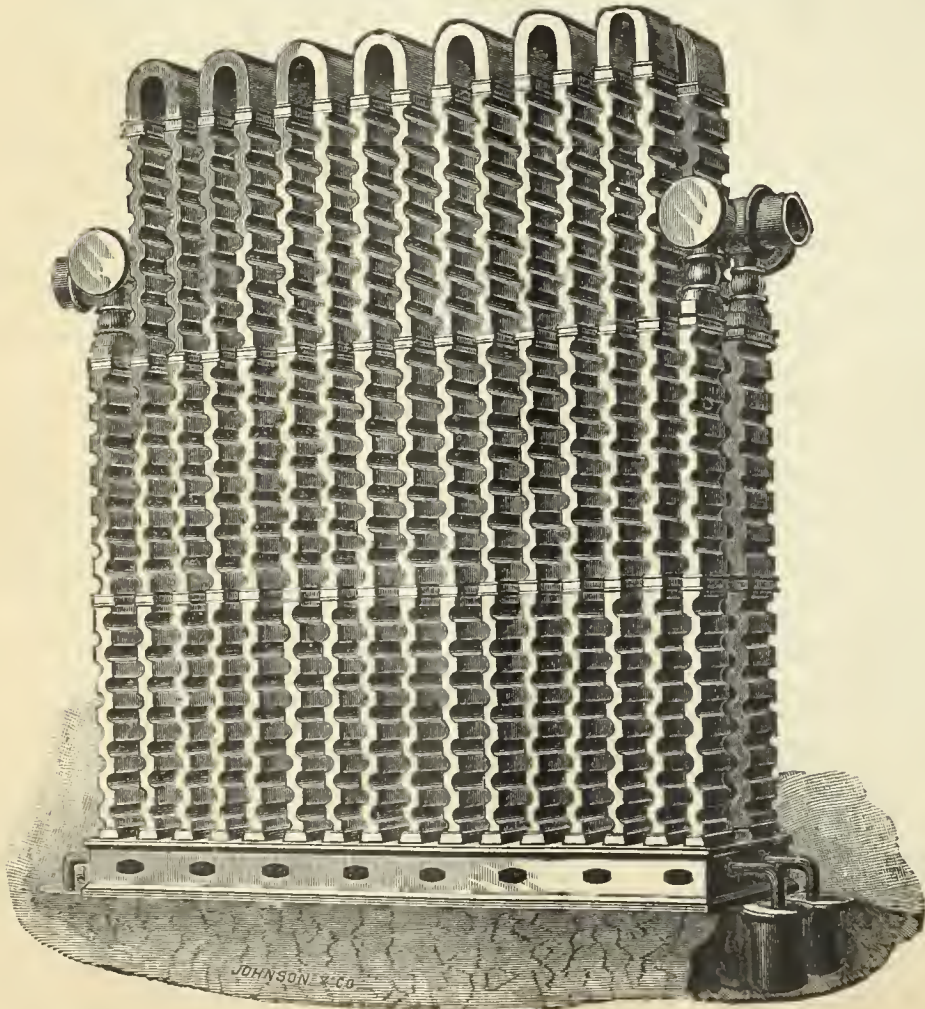

We desire to draw the attention of the gas community to the merits of the SINUOUS FRICTION CONDENSER. Companies intending to introduce new condensers into their works will do well to confer with us and examine plans and estimates before contracting for any other pattern. The FRICTION CONDENSER is now in use at the gas works located in the following places:

Portland, Me.	Brookline, Mass.	Pawtucket, R. I.	Frederickton, N. B.
Newport, R. I.	Chelsea, Mass.	Jamaica Plain, Mass.	St. John, N. B.
Gloucester, Mass.	Woburn, Mass.	Attleboro, Mass.	Paterson, N. J.
Newton & Water- town, Mass.	Peoria, Ill.	Calais, Me.	Dover, N. H.
	Clinton, Mass.	Fall River, Mass.	Waltham, Mass.
		Nassau Works, Brooklyn, N. Y.	

DAVIS & FARNUM MFG. CO.

MANUFACTURERS OF

Gas and Water Pipes,

AND

GAS AND WATER MACHINERY

OF THE MOST APPROVED PATTERN.

Also, Gasholders and Iron Roofing.

Orders from Gas and Water Companies promptly attended to.

WALTHAM, MASS.

Boston Office, Room 55, Mason Building, 70 Kilby Street.

CONNELLY & CO., LTD.,

SOLE MANUFACTURERS OF THEIR PATENTED SPECIALTIES.

"IRON SPONGE." Saves money, saves labor, and is the most efficient purifying agent ever offered as a substitute for lime. Now used in every State in the Union, and purifying daily over twenty-five million cubic feet. Should be used in every gas works. Its own saving will pay for it many times over.

AUTOMATIC GOVERNOR. Has been on the market but two years, and in that time has been introduced more generally than any invention ever designed for use in gas works. Over one hundred of them now in use. Sensitive; reliable; perfectly automatic; reduces leakage; satisfies consumers, and gives great relief to the Manager. No gas works is complete without one of these machines.

STEAM JET EXHAUSTER. Designed particularly for small works. Combines Exhaust Tube, Steam Governor, Gas Compensator, and Bye-Pass Valves in the most compact form possible; occupies but little space; uses very little steam; operated by ordinary workmen; saves formation of carbon in retorts; increases yield 10 to 15 per cent. Specially adapted for mixing air with oil gas. No works too small to use them profitably.

Prices given on all our specialties delivered at any point in the United States. Correspondence solicited.

CONNELLY & CO., LTD., No. 177 Broadway, New York City.

WILBRAHAM GAS EXHAUSTER

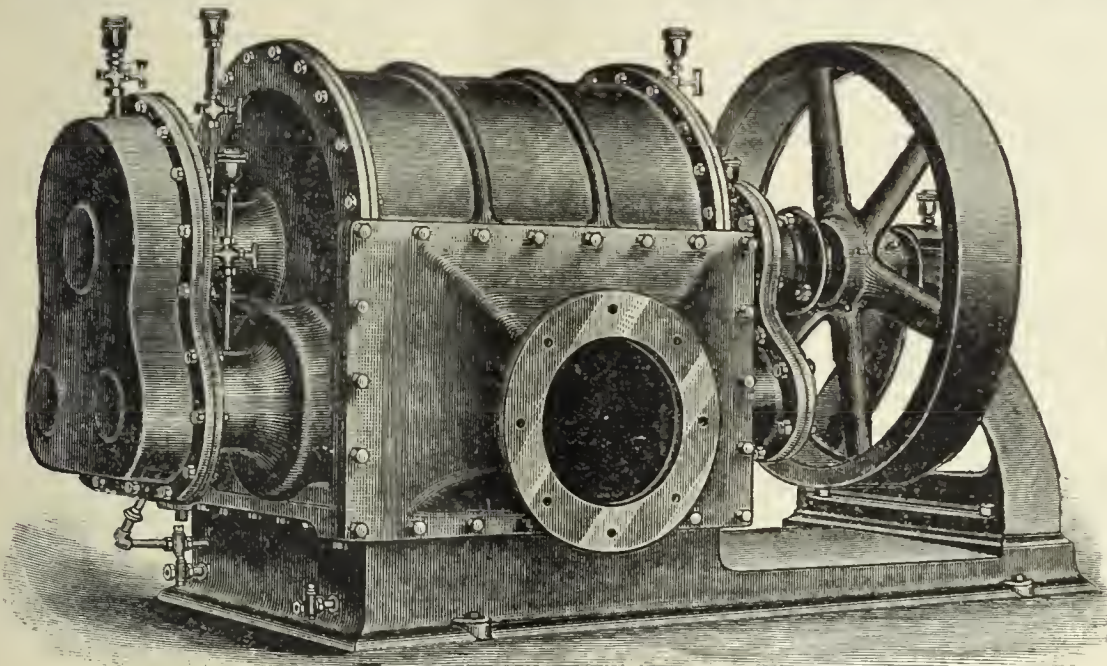

WILBRAHAM BROS.,
PHILADELPHIA, PA.

JARVIS ENGINEERING CO.,

61 Oliver St., Boston, Mass.

CONTRACTORS FOR ERECTING

COMPLETE STEAM OUTFITS FOR ELECTRIC LIGHTING STATIONS.

Steel Boilers set with Jarvis Pat. Boiler Setting,

To burn **COKE SCREENINGS** for Fuel.

ARMINGTON & SIMS CO. ENGINES,

Belting direct to Dynamos, without using Shafting.

SEND FOR CIRCULARS.

REFERENCES.—Charlestown Gas & Electric Light Co., Charlestown, Mass.; Schenectady Gas & Electric Light Co., Schenectady, N. Y.; Brookline Gas Co., Brookline, Mass.

Improved Patent
GAS BAG OR
BLADDER VALVE.

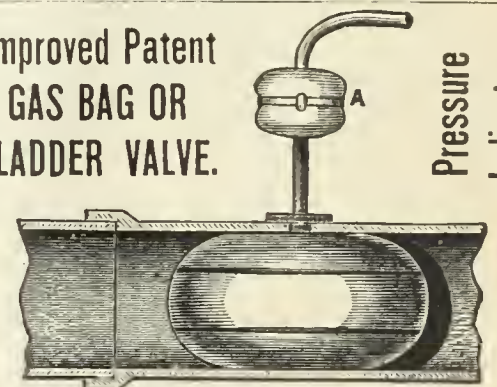

Pressure
Indicator.

MANUFACTURED BY
PEERLESS MFG. CO., 34 Murray St., N.Y.

THE CLERK GAS ENGINE CO.,

Main Office, 1012, 1014, 1016, 1018 Filbert St., Philadelphia, Pa.

WM. W. GOODWIN, Prest.

E. STEIN, Sec.

S. LEWIS JONES, Asst. Sec.

A. J. DOTY, Supt.

The utility and convenience of the Gas Engine being no longer an open question, it only remains now for intending purchasers to select the BEST. We claim for the CLERK GAS ENGINE that it is equal to any other manufactured as regards steadiness in running, simplicity, and ease of keeping in repair, and that it gives the greatest amount of power for the least money (both in first cost and expense of running) of any engine made. In support of this claim we refer to the test of the Gas Engines made under the direction of the American Institute of New York, in December, 1885, and heretofore published in these columns. These engines are especially adapted for continuous running under heavy loads, and we can refer to Engines which have run 22 hours a day for months at a time.

Made in Sizes of 5, 10, 15, 20, and 25 Horse Power. All Engines Guaranteed for One Year.



CHAPMAN VALVE MANUFACTURING CO.,

MANUFACTURERS OF

Valves and Gates for Gas, Ammonia, Water, Etc.

Also, Gate Fire Hydrants With and Without Independent Nozzle Valve. All Work Guaranteed.

WORKS & GEN'L OFFICE: Indian Orchard, Mass. TREASURER'S OFFICE: 72 Kilby & 112 Milk Sts, Boston, Mass.

LUDLOW VALVE MFG. CO.

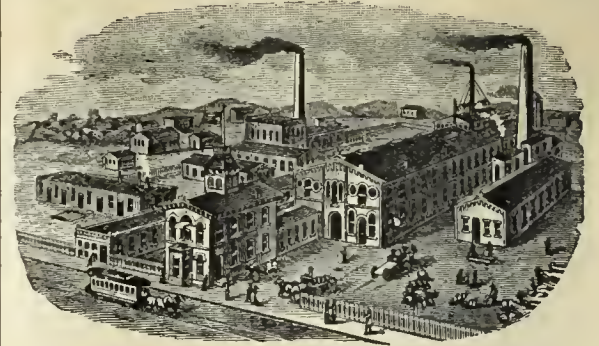

OFFICE AND WORKS,
938 to 954 River Street and 67 to 83 Vail Av.
TROY, N. Y.

How to Reduce Leakage to Its Minimum.

USE

HOPPER'S AUTOMATIC DIFFERENTIAL GAS GOVERNOR.

Needs No Attention. Simple, Reliable, Perfectly Automatic.
"Nearly Thirty in Use."

BYE-PASSES, DRY CENTER VALVES, PRESSURE REGISTERS. Also, GOVERNORS FOR STREET MAINS, *NOT DIFFERENTIAL*, and for EXHAUSTERS, GAS ENGINES, etc.

Our new Bye-Pass is threefold in its action—passes gas through, or bye-passes, or shuts off entirely. Correspondence solicited; information given. Send for circulars and testimonials.

T. C. HOPPER & CO., - - No. 2227 Wood Street, Philadelphia, Pa.

G. S. COOK, Pres. THOS. DAVENPORT (late Davenport Bros.), Sec. & Treas

BARTLETT Street Lamp Mfg. Co.

MANUFACTURERS OF

Bartlett's Patent

GLOBE LAMPS,

FOR

Streets, Parks, Railroad Stations, Public Buildings, Etc.

LAMP POSTS A SPECIALTY.

Office and Salesroom

40 & 42 College Place, N. Y. City.

Gas Companies and others intending to erect lamps and posts will do well to communicate with us.

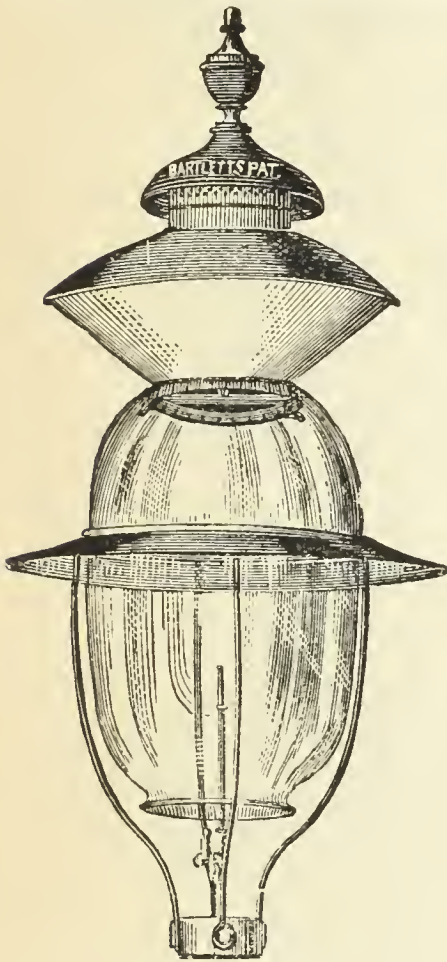

Hydraulic Main Dip Regulators, also Check Valves, Foot Valves, Yard-wash and Fire Hydrants. Send for Circulars.

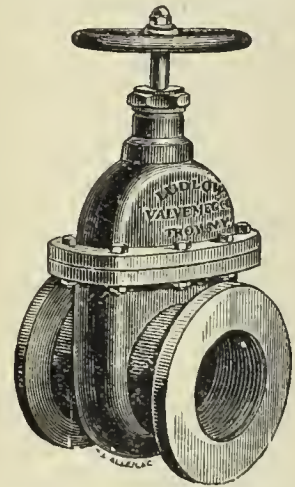

Valves.—Double and Single Gate, 1/2 in. to 48 in., outside and inside Screws. Indicator, etc., for Gas, Water, Steam, and Oil. Send for Circulars.

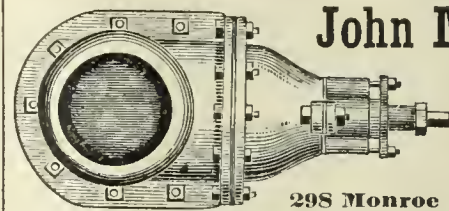

John McLean

Manufacturer of
GAS VALVES.

298 Monroe Street, N. Y.

MITCHELL, VANCE & CO.,

MANUFACTURERS OF

Chandeliers

and every description of

GAS FIXTURES.

Also manufacturers of Fine Gilt Bronzes and Marble Clocks, warranted best time-keepers. Mantel Ornaments, etc.

Salesrooms, 836 Broadway, N. Y.

Special Designs furnished for Gas Fixtures for Churches, Public Halls, Lodges, etc.

GAS AS A SOURCE OF LIGHT, HEAT, AND POWER.

By C. J. R. HUMPHREYS

A Pamphlet of twenty-nine pages, treating of the use of Gas as a source of Light, Heat, and Power.

DESIGNED FOR DISTRIBUTION BY GAS COMPANIES AMONG THEIR CUSTOMERS AND OTHERS.

Price, 10 cents each, \$5 per 100, \$50 per 1,000.

Gas Companies can have their own imprint placed on cover without extra charge. All orders to be sent to

A. M. CALLENDER & CO.,

No. 42 Pine Street, N. Y. City.

GAS STOVES.

GAS STOVES.

GAS STOVES.

THE AMERICAN METER CO.,

MANUFACTORIES,

508 to 514 West Twenty-second St., N. Y.

Arch and Twenty-second St., Phila.

Nos. 244 & 246 North Wells Street, Chicago, Ill.

AGENCIES,

No. 177 Elm Street, Cincinnati, Ohio.

Nos. 122 & 124 Sutter Street, San Francisco Cal.

No. 810 North Second Street, St. Louis, Mo.

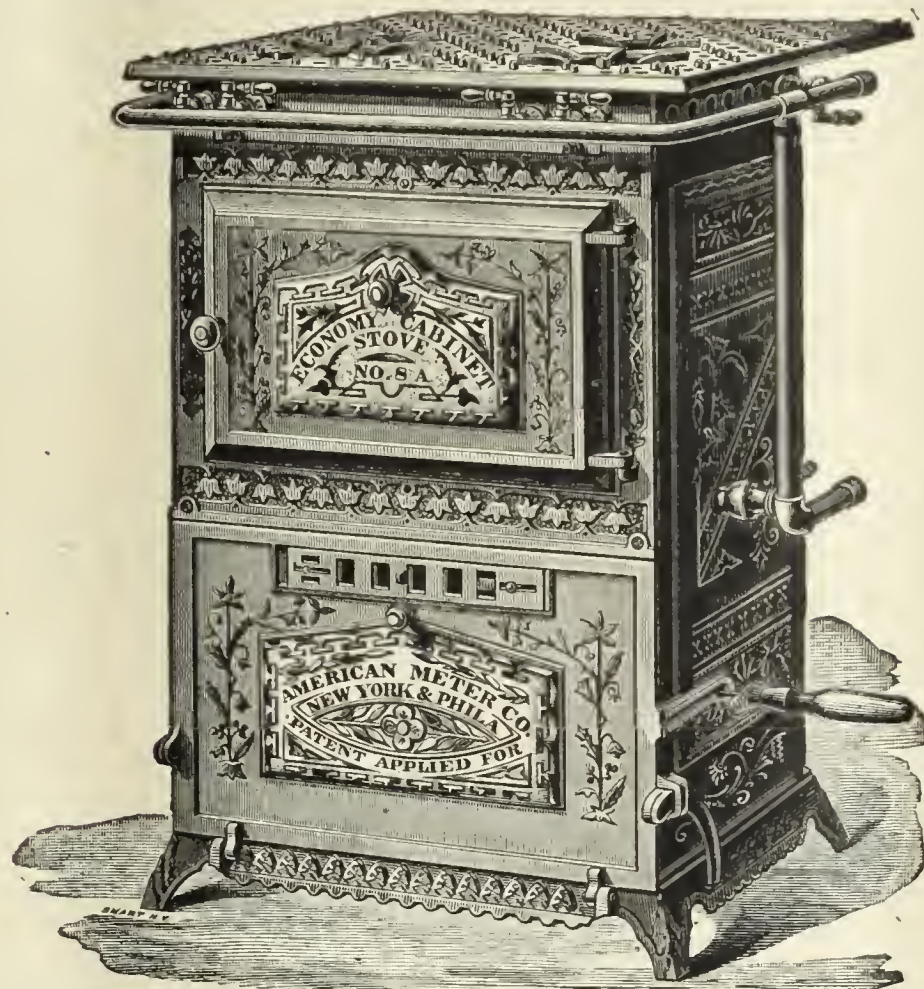

New Design Cast Iron "Economy" Cabinet Stoves.—With Open or Closed Top.

THE COMPANY MANUFACTURES

GAS STOVES FOR COOKING AND HEATING PURPOSES,

In All Sizes, for Domestic, Restaurant, and Hotel Use.

Also,

A Variety of Apparatus for Mechanical Purposes, Using Gas as Fuel.

These Stoves may be seen in operation at our Retail Store, No. 223 Sixth Avenue, N. Y. Call and examine.

SEND FOR ILLUSTRATED CATALOGUE SHOWING THE VARIOUS STYLES AND SIZES.

RETORTS AND FIRE BRICK.

J. H. CAUTIER & CO.,
 CORNER OF
GREENE AND ESSEX STREETS,
JERSEY CITY, N. J.

MANUFACTURERS OF

Clay Gas Retorts,
Gas House Tiles,
Fire Bricks, Etc. Etc.

Ground Clay, Fire Brick and
 Fire Sand in Barrels,

J. H. GAUTIER. T. B. GAUTIER.
 C. E. GREGORY. C. E. GAUTIER.

RETORTS AND FIRE BRICK.

LACLEDE FIRE BRICK MFG. CO.,
 MANUFACTURERS OF

Fire Brick, Gas Retorts,
 AND
ST. LOUIS STANDARD SEWER PIPE.

Blast Furnace and Cupola Linings, every description of Fire
 Clay Material, Fire Clay Flue Linings, Chimney Tops
 Dry Milled and Crude Fire Clays, etc.

OFFICE AND DEPOT
 901, 903, and 905 Pine Street,
 ST. LOUIS, MO.

RETORTS AND FIRE BRICK.

MANHATTAN
 FIRE BRICK & ENAMELLED CLAY
RETORT WORKS.
ADAM WEBER.

CLAY GAS RETORTS
AND RETORT SETTINGS
FIRE BRICKS, TILES, ETC.,
 Office and Works, 15th Street and Avenue C., N. Y.

BROOKLYN
Clay Retort & Fire Brick Works,
 (EDWARD D. WHITE & CO.)
 Manufacturers of Clay Retorts, Fire Brick,
 Gas House and other Tile.

VAN DYKE, ELIZABETH, RICHARDS & PARTITION STS.
 Office, 88 Van Dyke St., Brooklyn, N. Y.

ESTABLISHED IN 1845.

B. KREISCHER & SONS,
 OFFICE FOOT OF HOUSTON ST., E.R., N.Y.

Gas Retorts,
TILES, FIRE BRICK.
AND EVERYTHING IN THE FIRE CLAY LINE.



Works, LOCKPORT STATION, PA. **—ESTABLISHED 1864.—** Office, Rooms 19 & 20, Lewis Block, PITTSBURGH, PA, P. O. Box 373.

JAMES GARDNER, JR.,
 Successor to WILLIAM GARDNER & SON.

Fire Clay Goods for Gas Works.
 CHAS. H. SPRAGUE & SON, No. 70 KILBY STREET, BOSTON, MASS., Agents for the New England States.

OFFICE, 418 to 422 East 23d St., New York. **ESTABLISHED 1856.** WORKS, PERTH AMBOY, NEW JERSEY.

HENRY MAURER & SON,
Excelsior Fire Brick & Clay Retort Works
 CLAY GAS RETORTS, BENCH SETTINGS, FIRE BRICK, TILES, ETC.

CHICAGO
Retort & Fire Brick Works,
 OFFICE AND FACTORY,
 Clark, Forty-Fifth, and La Salle Streets,
CHICAGO, ILL.

GEORGE C. HICKS, PRES. PAUL P. AUSTIN, SEC. & TREAS.

STANDARD
Clay Retorts and Settings.
BLOCKS & TILES
 Of every Shape and Size to Order.
Standard Fire Bricks.

OAKHILL
GAS RETORT & FIRE BRICK
 Works.

Proprietors,
PARKER-RUSSELL MINING & MFG. CO.
 City Office, 711 Pine Street,
ST. LOUIS, MO.

THOS. SMITH, Prest. AUGUST LAMBLA, Vice-Prest. & Sup

BALTIMORE
RETORT & FIRE BRICK CO.
 MANUFACTORY AT
LOCUST POINT, BALTIMORE, MD.
 Connection with the City by Telephone.

Clay Retorts, Blocks & Tiles,
FIRE BRICK, FIRE CLAY,
AND FIRE CEMENT.

Red and Buff Ornamental Tiles and Chimney
 Tops. Drain and Sewer Pipe (from
 2 to 30 inches). Baker Oven Tiles
 12x12x2 and 10x10x2.

WALDO BROS., 88 WATER ST., BOSTON, MASS
 Sole Agents the New England States.

GEROULD'S IMPROVED RETORT CEMENT.
 A Cement for patching retorts, putting on mouthpieces, and
 making up all bench-work joints. This Cement is mixed ready
 for use. Economic and thorough in its work. Fully warranted
 to stick. For recommendations and price list address

C. L. GEROULD,
 Manchester, N. H.
 Western Agent, H. T. GEROULD, Mendota, Ill.

Our immense establishment is now employed almost entirely in
 the manufacture of

MATERIALS FOR GAS COMPANIES.

We have studied and perfected three important points. Our re-
 torts are made to stand changes of temperature, the strongest
 heats of the furnace, and the abrasion of feeding and emptying.
 Our customers are in almost every State of the Union, to all of
 whom we refer.

EVENS & HOWARD,
916 Market St., St. Louis. Mo.
Works, Howard Station, Mo. Pacific R.R.

Fire Brick, Gas Retorts

AND

RETORT SETTINGS.

Sewer Pipe, 3 to 24 in. diameter.

Glass Pot Clay, Ground Fire Clay, in barrels and in bulk. All kinds of Fire Clay Goods.

Cincinnati Gas Retort & Fire Brick Works.

—ESTABLISHED 1872.—

CHAS. TAYLOR,

MANUFACTURER OF

Gas Retorts, Fire Brick, and Tile.

Blast Furnace Linings, Cupola Blocks, Boiler Tiles, Grate Settings, and Stove Linings. Fire Cement, Fire Clay, Fire Sand, and all other Fire Clay Goods.

Branch Works, New Cumberland, W. Va.

GENERAL OFFICE AND WORKS,

Burns St., Cincinnati, Ohio.

Stettiner

**Chamotte Fabrik Actien
Gesellschaft,**

Formerly **DIDIER,**

(Patentees of the Dr. Schilling & Dr. Bunte
Regenerative Furnace)

STETTIN, GERMANY.

The attention of all Gas Engineers is called to our Fire-Proof Material, viz.:

CLAY GAS RETORTS

(ENAMELED AND UNENAMELED),

Blocks, Tiles

AND

EXTRA FIRE BRICK,

Pronounced by the highest authorities as superior to and exceeding any other similar manufacture. The component of aluminum contained in our material (up to 45 per cent.) is larger than in any other material heretofore sold in the United States; whilst the uniformity of the goods is assured by the most scrupulous analysis of the clay used.

For any further information and prices please apply to

EMIL LENZ,

2 & 4 Stone St., Room 19, N.Y. City.

PATENTS.

FRANKLIN H. HOUGH,

Solicitor of American & Foreign Patents

925 F. ST., WASHINGTON, D. C.

(NEAR U. S. PATENT OFFICE.)

Personal attention given to the preparation and prosecution of applications for Letters Patent. All business before the U. S. Patent Office attended to for moderate fees. **No Agency in the United States possesses superior facilities for obtaining Patents,** or for ascertaining the patentability of inventions. Copies of patents furnished for 25 cents each. Correspondence solicited.

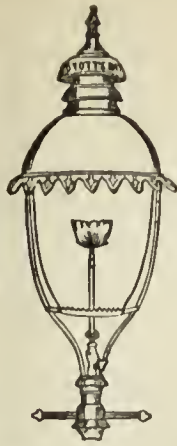

STEPHEN A. MORSE, President.
GODFREY REBMAN, Vice-Pres.

M. B. DYOTT,
Superintendent.

EDWIN F. MORSE, Secretary.
CARLTON M. WILLIAMS, Treas.

STANDARD GAS LAMP CO.,

Office, 411 Cherry St. Factory, 1101, 1103 & 1105 Frankford Av.

Philadelphia, Pa.

It is to the interest of Gas Companies and Cities to use Dyott's Patent Champion Lamps, which give double the light with the same consumption of gas, and will save 50 per cent. over others in cost of keeping in repair. Gas Companies and others intending to erect Lamps of any description will do well to communicate with us. Special Drawings furnished and Estimates given on application upon Architects', Engineers' or our Draughtsmen's Plans.

Our Patent System of Instantaneously Lighting Gas (without electricity) for R. R. Depots is unequalled. Our High Candle Power Burner is superior to the Electric Light or any other High Candle Burner. We manufacture every description of Ornamental Lamps.

KLOENNE & BREDEL

IMPROVED REGENERATIVE FURNACES.

Self-Sealing Mouthpieces & Bridge-Pipes, Retort Houses,

WASHER-SCRUBBERS,

Gasholders, and Complete Gas Works.

Refers, by permission, to Mr. Eugene Vanderpool, of Newark, N. J.; Mr. E. G. Cowdery, of Milwaukee, Wis.; and Mr. Theo. Forstall, of Chicago, Ill. For further information apply to

FRED. BREDEL, 332 East 17th St., N. Y. City.

"RUSTLESS" IRON WATER PIPE.

RUSTLESS

Send for New Catalogue.

RUSTLESS

The WELLS RUSTLESS IRON COMPANY,

Nos. 7 and 9 Cliff Street, New York City.

GASHOLDER TANK CONSTRUCTION, ETC.

Gas Companies and others about to erect Gasholders will find it profitable to consult W. C. WHYTE, who for over thirty years has made a specialty of

Holder Tank Excavation and Mason Work.

Fifty tanks now in operation show the sort of work done. Address

W. C. WHYTE, No. 15 Cortlandt St., N. Y. City.

MILLS' REVERSIBLE LIME TRAY,

AND

WOODWORK

Of Every Description

NEEDED BY GAS WORKS.

SEND FOR CIRCULAR AND PRICE LIST TO

GEORGE A. MILLS,

Canton Av. & President St., Baltimore, Md.

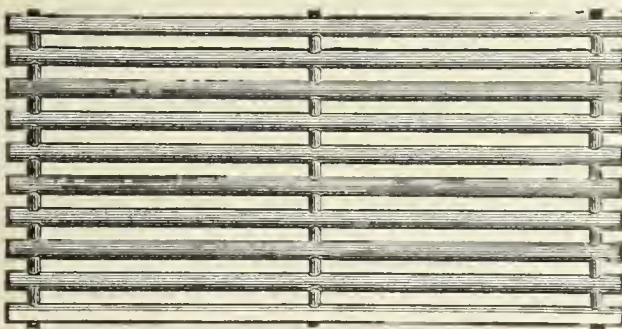

Ferric Oxide for Gas Purification.

Ferric Oxide, as ground, screened, and prepared by me for purifying purposes, has now been in use for several years by many of the gas works throughout the country, including Detroit, Chicago, Milwaukee, East Saginaw, Burlington (Iowa), Ann Arbor, etc. It has proved, as I believe, the **Most Effective and Economical Agent** now in use. I am prepared to furnish the Oxide by the 100 lbs. or in car load lots, and will be pleased to give price f.o.b. cars at Ann Arbor or at place of destination. Address

S. H. DOUGLAS, Prest. Ann Arbor (Mich.) Gas Light Co.

GAS AND WATER PIPES.

GAS AND WATER PIPES.

ENGINEERS.

SAM'L R. SHIPLEY, Pres.
HENRY B. CHEW, Treas.JAS. P. MICHELLON, Sec.
WM. SEXTON, Supt.

P. D. WANNER, Chairman. A. H. MELLERT, Sec. & Treas.

GLOUCESTER IRON WORKS,
GLOUCESTER CITY, N. J.

Cast Iron Gas & Water Pipes, Stop Valves, Fire Hydrants, Gasholders, &c.
Office No. 6 North Seventh Street, Philadelphia.

MATTHEW ADDY, President.

W. L. DAVIS, Selling Agent.

GEO. P. WILSHIRE, Sec. & Treas.

Cincinnati and Newport Iron and Pipe Company,
NEWPORT, KY.

Lamp Posts

AND

BENCH CASTINGS

A Specialty.

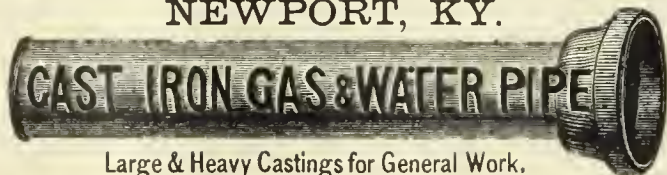

Large & Heavy Castings for General Work.

Branch

AND

SPECIAL CASTINGS

FOR GAS & WATER CO'S.

Manufacture Pipe from 2 to 48 inches. All work guaranteed first quality.

Pancoast & Rogers.**WROUGHT IRON PIPE,**

VALVES AND GATES,

Cast Iron Gas & Water Pipe.

28 Platt and 15 Gold St., New York.

GEO. SHEPARD PAGE,

No. 69 Wall Street, N. Y. City.

REPRESENTING

THE BOWER GAS LAMP.

C. & W. Walker's Carbonic Acid & Tar Extracting Washer

B. DONKIN & CO.'S PAT. IMP. GAS VALVE.

Young & Beilby's Patents. Henry Aitkin's Patents.

R. P. SPICE, London, Eng. HENRY SIMON, Manchester, Eng.

The Management of Small Gas Works.

By C. J. R. HUMPHREYS. Price, \$1.

A. M. CALLENDER & CO., 42 Pine St., N. Y.**MELLERT FOUNDRY & MACHINE CO., Ltd.**
Reading, Pa.Specials—Flange Pipe, Valves and Hydrants,
Lamp Posts, Retorts, etc.

General Foundry and Machine Work.

JOHN FOX, Selling Agent. 160 Broadway, N. Y.

THE OHIO PIPE COMPANY,

MANUFACTURERS OF

Cast Iron Gas & Water Pipe,

BRANCH AND SPECIAL CASTINGS.

Gas-House Bench Castings, Hydraulics, Lamp Posts, Flange Pipe
and Specials, Architectural Castings, Building Columns,
Joists, Cellar Grates, Sash Weights, etc.

GENERAL FOUNDERS AND MACHINISTS.

Columbus, Ohio.

M. J. DRUMMOND,

SPECIAL CASTINGS AND LAMP POSTS.

Equitable Building, 120 Broadway, N. Y.

JOS. R. THOMAS, C.E.,May be Consulted on all Mat-
ters Relating to Gas Works
and Gas Manufacture.

ADDRESS THIS OFFICE.

WM. MOONEY

(Successor to WM. FARMER)

27 Pearl Street, N. Y. City.

(One door from Whitehall Street.)

CONTRACTOR FOR THE ERECTION OF GAS WORKS, OR
APPARATUS OF ANY CAPACITY. AGENT FOR
WM. FARMER'S PATENTS.

Plans and Specifications Furnished.

WM. HENRY WHITE,

CONSULTING AND CONSTRUCTING

Gas Engineer & ContractorEstimates, Plans, and Specifications furnished for new works or
extensions of existing works.

No. 32 Pine Street, New York City.

Correspondence solicited.

WM. GARDNER,**Gas Engineer,**

Lewis Block, Room 20, Pittsburgh, Pa.

Those who intend to make alterations in existing gas plants, or
who contemplate the erection of new works, will find it to their
interest to open correspondence with the above. Plans made
and estimates furnished.

GAS LAMPS.

SCRUBBERS AND CONDENSERS.

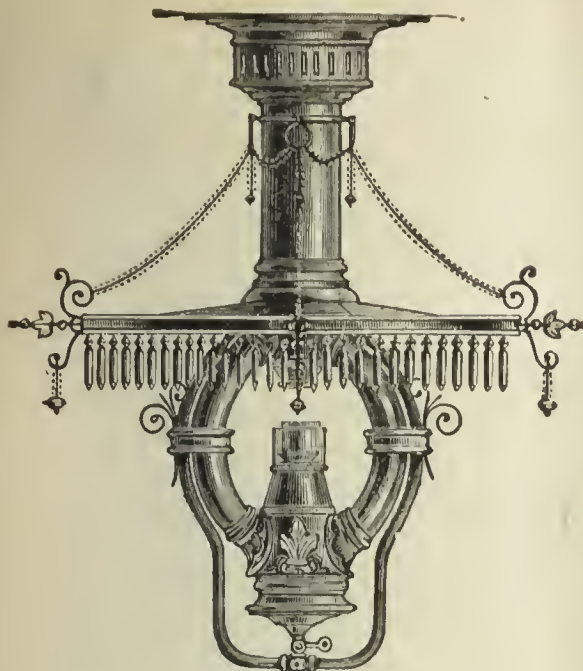

SIEMENS LAMP.

The Siemens and Lungren REGENERATIVE GAS LAMPS.

A System of Burning Gas whereby its Illuminating Power is Increased from 300 to 400 per ct. without the Expense, Trouble and Annoyance resulting from the use of Hydrocarbon Enriching Material.

The Siemens-Lungren Company received the only Silver Medal or Highest Award for Gas Burners at the "Novelties" Exhibition of the Franklin Institute, held at Phila., Oct., '85.

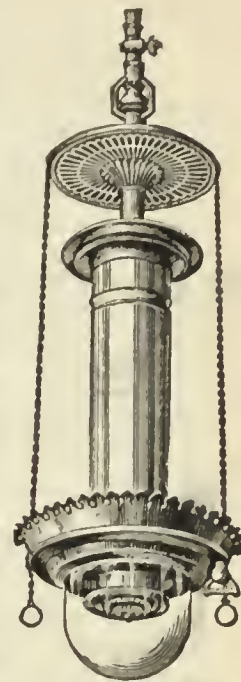

LUNGREN LAMP

THIRTEEN CANDLE POWER PER CUBIC FOOT OF GAS!

This result is obtained

SIMPLY BY THE SCIENTIFIC APPLICATION OF THE REGENERATIVE PRINCIPLE.

Consequently this largely increased illumination is always maintained without further cost and frequent attention.

THE SIEMENS-LUNCREN COMPANY,

N. E. Cor. 21st. St. and Washington Av., Phila., Pa.

THE PATENT "STANDARD" WASHER-SCRUBBER

(KIRKHAM, HULETT & CHANDLER PATENT.)

Has been adopted by gas companies in all parts of the world. Between 300 and 400 companies, with the enormous daily output of over 300,000,000 cubic feet, are now using it. "Standard" Washer-Scrubbers have been erected for the following gas light companies since Jan. 1, 1886:

WALLASEY, ENGLAND.....	750,000 cubic feet.	RICHMOND, SURREY, ENGLAND.....	1,500,000 cubic feet.
NEWARK, ENGLAND.....	350,000 "	BRIDGEPORT, U. S.....	500,000 "
BUFFALO, U. S. (MUTUAL).....	500,000 "	TORONTO, CANADA.....	1,000,000 "
BERLIN, GERMANY.....	1,250,000 "	HARTFORD, U. S.....	1,000,000 "
SO. BRISBANE, AUSTRALIA.....	300,000 "	DETROIT, U. S.....	750,000 "
LEEDS, ENGLAND.....	2,000,000 "	SINGAPORE, CEYLON.....	300,000 "
FURTH, GERMANY.....	400,000 "	BRUNSWICK, GERMANY.....	300,000 "
FREIBURG, GERMANY.....	200,000 "	LILLE, FRANCE.....	750,000 "
NINE ELMS, LONDON.....	3,000,000 "	CADIZ, SPAIN.....	300,000 "
MELBOURNE, AUSTRALIA (2).....	3,000,000 "	READING, ENGLAND.....	2,000,000 "
GLUCKAUF COKE WORKS, GERMANY.	200,000 "	LINCOLN, U. S.....	250,000 "
BOURNEMOUTH, ENGLAND.....	1,000,000 "	ST. LOUIS, U. S. (LACLEDE).....	1,000,000 "
		BROOKLYN, U. S.....	2,000,000 "
		BROOKLYN, U. S. (NASSAU).....	1,000,000 "
		DENVER, U. S.....	1,000,000 "

That this apparatus is really the *standard* is indicated by the following names of important houses who represent this invention in the different countries of the world:

FRANCE & BELGIUM, Mons. J. A. Berly, 31 Rue Boinod, Paris. HOLLAND & DUTCH COLONIES, Mess. W. Hoven & Zoon, Rotterdam.

GERMANY and AUSTRO-HUNGARY, Berlin-Anhaltische-Actiengesellschaft, Berlin, Moabit, and Dessau.

RUSSIA, Mr. F. Bley, Galernaya, 44, St. Petersburg. SPAIN, Mess. Nicolas, Chamon, Foiret & Cie., 29 Rue Claude-Vellefaux, Paris.

ITALY & MALTA, Sig. E. Canziani, 26 & 28 Portici, Vittorio Emmanuele, Genoa. Sig. Fratelli Scheuer, Via Chiaja, 124, Naples

NEW SOUTH WALES, Messrs. W. Coward & Sons, 143 Queen Victoria St., London.

NEW ZEALAND and VICTORIA, Messrs. G. D. Jennings & Co., 28 Gracechurch St., London.

Companies in the U. S. adopting this apparatus can now be assured of a market for the Ammoniacal Liquor at a remunerative price. Correspondence for purchase of "Standards" and Ammoniacal Liquor is solicited by the

GEO. SHEPARD PAGE, 69 WALL STREET, NEW YORK.

GAS WORKS APPARATUS AND CONSTRUCTION.

GAS WORKS APPARATUS AND CONSTRUCTION.

WORKS: { MILLVILLE, N. J.
FLORENCE, " "
CAMDEN, " "

R. D. WOOD & CO.,

OFFICES: { 400 CHESTNUT ST.,
PHILADELPHIA.

CAST-IRON PIPE 1½ to 72 Inches in Diameter.

Water Machinery and Gas Apparatus.

HEAVY CASTINGS.

HOLDERS,

LAMP POSTS,

VALVES,

PURIFIERS,

CONDENSERS,

BENCH WORK,

METER CASES.

FLOORS AND ROOFS,

FLANGED PIPE,

FIRE HYDRANTS,

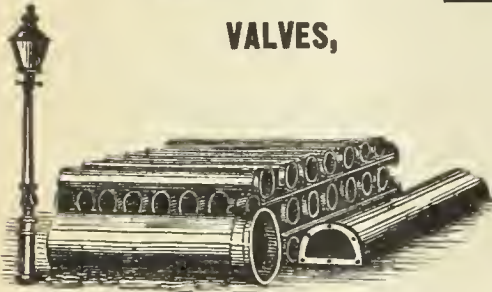

Estimates and Specifications for
NEW WORKS or **EXTENSIONS**
or **ALTERATIONS** of **OLD ONES.**

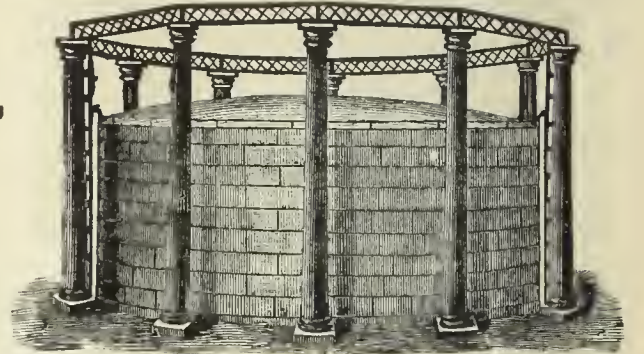

SOUTHWARK FOUNDRY AND MACHINE COMPANY,

Successors to MERRICK & SONS,

GAS APPARATUS,

Holdings, Purifiers, Washers, Etc., Etc. Boiler and Tank Work. Steam Engines.
Hydraulic Machinery. Bessemer Plants, Etc.

Washington Ave. and Fifth Street, Philadelphia, Pa.

MORRIS, TASKER & CO.,

Limited,

Builders of Gas Works,

PHILADELPHIA PA.

THE KERR MURRAY MANUFACTURING COMPANY,

Fort Wayne, Ind.

CONSTRUCTING ENGINEERS AND BUILDERS OF

GAS WORKS AND HOLDERS.

Drawings, Estimates, and Specifications Furnished for the Construction of New and the Rebuilding of Old Works.

MANUFACTURERS OF LATEST IMPROVED APPARATUS FOR COMPLETE AND AUXILIARY OIL AND WATER GAS PLANTS.

Rotary and Steam Jet Exhausters, Rotary Washers, Self-Sealing Mouthpieces,

HYDRAULIC LIFTS FOR PURIFIER COVERS.

"VALVE COMBINATION" FOR OPERATING ONE TO FOUR OR MORE PURIFIERS.

Street Specials, Valves, and Fittings.

COKE CRUSHERS, COAL AND COKE WAGONS, LAMP POSTS.

Iron Roofs, Cutters, and Retort House Floors.

STEAM ENGINES AND BOILERS, IRON COAL SHEDS.

Single and Telescopic Gasholders.

Correspondence is Respectfully Solicited.

GAS WORKS APPARATUS AND CONSTRUCTION.

GAS WORKS APPARATUS AND CONSTRUCTION.

JAMES R. FLOYD,

(SUCCESSOR TO HERRING & FLOYD)

Oregon Iron Works,

531 to 543 West 20th St., N. Y.

Practical Builders of Gas Works,

MANUFACTURERS OF

ALL KINDS OF CASTINGS

AND

APPARATUS FOR GAS-WORKS.

BENCH CASTINGS

From benches of one to six Retorts each.

WASHERS: MULTITUBULAR AND AIR CONDENSERS; CONDENSERS; SCRUBBERS

(wet and dry), and

EXHAUSTERS

for relieving Retorts from pressure.

BENDS and BRANCHES

all sizes and description.

FLOYD'S PATENT

MALLEABLE RETORT LID.

PATENT

SELF-SEALING RETORT LIDS.

FARMER'S

PATENT BYE-PASS DIP-PIPE.

SABBATON'S PATENT

FURNACE DOOR AND FRAME.

BUTLER'S

COKE SCREENING SHOVELS.

GAS GOVERNORS,

and everything connected with well regulated Gas Works at low price, and in complete order.

SELLER'S CEMENT

for stopping leaks in Retorts.

N. B.—**STOP VALVES** from three to thirty inches—at very low prices.

Plans, Specifications, and Estimates furnished.

GAS vs. ELECTRIC LIGHT.

We would invite attention to the able and exhaustive argument of General A. Hickenlooper, President of the Cincinnati Gas Light and Coke Company, contained in a handsome pamphlet of 96 pages, entitled

"EDISON'S INCANDESCENT ELECTRIC LIGHTS FOR STREET ILLUMINATION. REPORT OF AN ARGUMENT DELIVERED BY A. HICKENLOOPER BEFORE THE COMMITTEE ON LIGHT, MUNICIPAL COUNCIL, CITY OF CINCINNATI, JULY 22, 1886."

This is a subject of special interest to all Gas Light Companies.

Prices.

25 copies..... \$7.50 100 copies..... \$22.50
50 copies..... 12.50 250 copies..... 50.00

A sample copy will be sent by mail on receipt of 50 cts.

A. M. CALLENDER, & CO., 42 PINE ST., N. Y. CITY.

CONTINENTAL WORKS.



GASHOLDERS OF ANY MAGNITUDE.

T. F. ROWLAND, Proprietor,
GREENPOINT, BROOKLYN, N. Y.

ENGINEER AND MANUFACTURER OF

GAS-HOLDERS.

CONDENSERS, SCRUBBERS, VALVES,

PURIFIERS, RETORTS, and HY-

DRAULIC MAINS,

and all other articles connected with the Manufacture and Distribution of Gas. Plans and Specifications prepared and Proposals given for the necessary Plant for Lighting Cities, Towns, Mansions, and Manufactories.

H. RANSHAW, Prest. & Mangr. WM. STACEY, Vice-Prest. T. H. BIRCH, Asst. Mangr. R. J. TARVIN, Sec. & Treas.

STACEY MFG. CO.,

MANUFACTURERS OF

Single and Telescopic Gasholders,

IRON ROOFS, BRIDGES, LAMP POSTS.

Water and Oil Tanks, Coal Elevator Cars,

COKE CRUSHERS, BENCH CASTINGS,

And all kinds of Wrought and Cast Iron Work used in the erection of Coal and Oil Gas Works. Rolling Mill Machinery and Heavy Castings a Specialty.

Foundry:

33, 35, 37 & 39 Mill Street.

Wrought Iron Works:

16, 18, 20, 22, 24 & 26 Ramsey Street.

Cincinnati, Ohio.

1842. **DEILY & FOWLER,** 1887.

Laurel Iron Works.

Address, No. 39 Laurel Street, Philadelphia, Pa.

MANUFACTURERS OF

GASHOLDERS,

Single or Telescopic, with Cast or Wrought Iron Guide Frames.

HOLDERS BUILT SINCE 1881:

- | | | | | |
|-----------------------|---------------------------|---------------------------|----------------------------|----------------------------|
| Scranton, Pa. (2d) | Hollidaysburg, Pa. | Jackson, Mich. | Montgomery, Ala. | New Castle, Pa. |
| West Point, N. Y. | Galveston, Texas (2d.) | Kalamazoo, Mich. (3d.) | Newport, R. I. | Long Island City, N. Y. |
| Fitchburgh, Mass. | Marlboro, Mass. | Glen Island, N. Y. | Portland, Oregon. | Macon, Ga. |
| New London, Conn. | Denver, Col. | Warren, Ohio. | Allegheny, Pa. (2d.) | York, Pa. |
| Derby, Conn. | Chicago, Ill. (West Side) | Bath, N. Y. | Atlanta, Ga. (2d.) | Chester, Pa. |
| Bridgeport, Conn. | Pittsburgh, Pa. (S. Side) | Lynn, Mass. | N.Y. City (Central Gas Co) | Hazleton, Pa. (2d.) |
| Allegheny, Pa. (1st.) | Pawtucket, R. I. | New Bedford, Mass. | Lynchburg, Va. (2d.) | Novelties Exh'., Phila |
| St. Hyacinth, Can. | Brookline, Mass. | Waterbury, Conn. | Saylesville, R. I. | State Island, N. Y. |
| Norwalk, O. | Sherbrooke, Can. | Deseronto, Can. | Rondout, N. Y. | Saugerties, N. Y. |
| Brattleboro, V. | Burlington, N. J. (2d.) | Hoosic Falls, N. Y. (2d.) | Atlantic City, N. J. | Clinton, Mass. (Lan. Mills |
| Waltham, Mass. (2d.) | Bridgeton, N. J. | Bethlehem, Pa. | Angusta, Ga. | Chattanooga, Tenn. |
| West Chester, Pa. | Bay City, Mich. | Atlanta, Ga. (1st.) | Waltham, Mass. (2); | Galveston, Texas. (3d.) |
| Baltimore, Md. | Erie, Pa. | Savannah, Ga. | Mahanoy City, Pa. | Omaha, Neb. |

SMITH & SAYRE MFG. COMPANY,

G. PORTER, Prest.

245 Broadway, N. Y.

CHAS. W. ISBELL, Sec'y.

Machinery & Apparatus for Gas Works

Drawings, Plans, and Estimates Furnished for the Improvement, Extension, or Alteration of Gas Works, or for the Construction of New Works.

Mackenzie's Patent Rotary and Steam Jet Gas Exhausters, Governors, Compensators, Condensers, Washers, Scrubbers. Isbell's Patent Automatic Street Pressure Governor, Gas and Water Valves, Hydraulic Main Dip Regulator, Bench Castings, etc. Purifying Boxes and "Standard" Scrubbers. Isbell's Patent Self-Sealing Retort Doors,

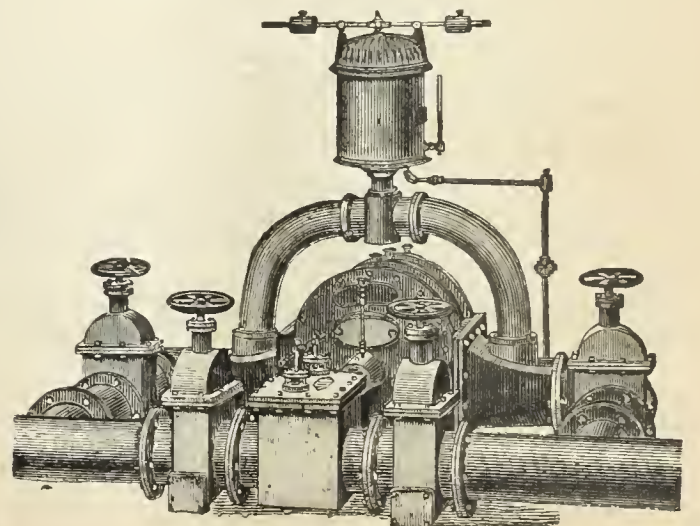

GAS COALS.

CANNEL COALS.

GAS ENRICHERS.

JAMES D. PERKINS.

PERKINS & CO.,

F. SEAVERN.

General Sales Agents for

The Youghioghenny River Coal Company's

OCEAN MINE YOUGHIOGHENY GAS COAL.

The Coal from the Ocean Mine (recently operated by *Messrs. W. L. Scott & Co.*, of Erie, Pa.,) is now used by all the leading Gas Companies in the United States from Maine to Texas, and is recognized as *the only reliable Youghioghenny Gas Coal.* (See Map on p. 87 of this Journal, Feb. 16, '85.)

P. O. Box 3695,
New York.

PERKINS & CO., 228 and 229 N. Y. Produce Exchange.

BEAVER STREET
ENTRANCE.

**BRECKENRIDGE CANNEL,
OF KENTUCKY.**

This Colliery was re-opened in June, 1886, since which date the Cannel has been delivered to over sixty of the leading Gas Companies in this country and in Europe. As an enricher ONE TON of this Cannel will do the work of TWO TONS of any other available Cannel, and is more economical than Naptha or Oil of any character. It can be delivered in parcels of one car load or more to any point in the United States or Canada.

(See AMERICAN GAS LIGHT JOURNAL, June 16, '86, pp. 346-7.)

P. O. Box 3695,
New York.

PERKINS & CO., 228 and 229 N. Y. Produce Exchange

BEAVER STREET
ENTRANCE.

**JAMES & WILLIAM WOOD,
Gas and Cannel Coal Contractors,**

No. 40 St. Enoch Sq., Glasgow. No. 2 Talbot Court, London.

Proprietors of the **BATHVILLE COLLIERIES** (which produce the celebrated **BOGHEAD CANNEL**), Shields, Shieldmuir, Drumpeller, and other Collieries. This Firm offer

STANDARD CANNELS,

Unequaled as Gas Enrichers.

Analyses, prices, and all further information furnished on application to

Agency for U. S., Room 93, Nos. 2 & 4 Stone St., N.Y. City.

The Standard Oil Company,

REFINERS OF

NAPTHA AND GASOLINES.

ALSO MANUFACTURERS OF

A Special Grade of Naptha for Gas Companies

FOR ENRICHING COAL GAS.

Correspondence solicited.

No. 43 Euclid Avenue, Cleveland, Ohio.

To Gas Companies.

We make to order **CAP BURNERS** to burn any amount under a stated pressure. Send for samples.

Also, **SERVICE CLEANERS, DRIP PUMPS, and STREET MAIN PROVING APPARATUS.**

C. A. GEFROHER,

248 N. 5th Street, Phila., Pa.

GOODWIN'S DIRECTORY

OF THE GAS LIGHT COMPANIES of the UNITED STATES & CANADA.

Price, **\$10.00.**

Orders may be sent to

A. M. CALLENDER & CO., No. 42 Pine Street, N. Y. City.

COKE CRUSHERS.

GAS COALS.

GAS COALS.

Newburgh Orrel Coal Co.,

MINERS AND SHIPPERS OF

Mountain Brook Steam and Smithing Coals,

AURORA, TYRCONNELL & PALATINE GAS COALS.

Foundry & Crushed Coke Shipped Direct from Ovens

Mines Situated at

Newburgh, Flemington & Fairmont, W. Va.

HOME OFFICE,

33 S. Gay St., Baltimore.

CHAS. MACKALL, Gen. Mangr.

CHAS. W. HAYS, Agent in New York,

Room 147, WASHINGTON BUILDING, No. 1 Broadway.

Shipping wharves at Locust Point, Baltimore.

THE DESPARD COAL COMPANY

OFFER THEIR SUPERIOR

DESPARD COAL

To Gas Light Companies and Manufacturers of Fire Clay Goods Throughout the Country.

ROUSSEL & HICKS, } AGENTS. { BANGS & HORTON, }
71 Broadway, N. Y. } 16 Kilby St., Boston.

Mines in Harrison Co., West Va. Wharves, Locust Point, Balt.

Company's Office, 15 German St., Baltimore, Md.

Among the consumers of Despard Coal we name: Manhattan Gas Light Co., N. Y.; Metropolitan Gas Light Co., N. Y.; Jersey City, (N. J.) Gas Light Co.; Washington (D. C.) Gas Light Co.; Portland (Maine) Gas Light Co. Reference to them is requested.

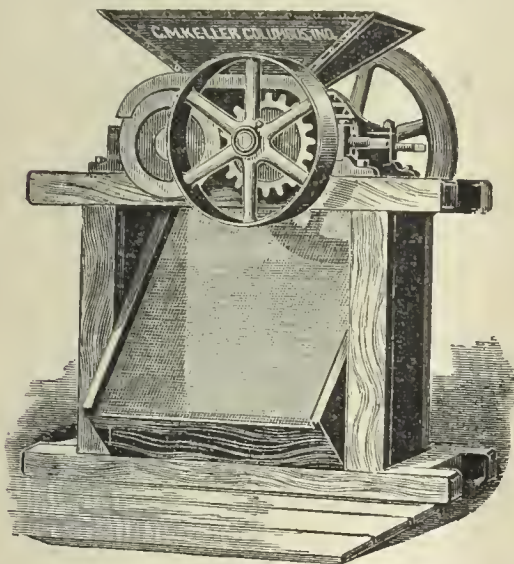

Keller's Adjustable Coke Crusher.

SIMPLE, STRONG, AND DURABLE.

C. M. Keller, Sec. & Supt. Gas Lt. & Coke Co. Columbus, Ind.

Correspondence Solicited.

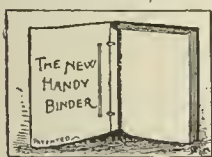

THE NEW HANDY BINDER.

This article may be described as elegant in appearance, strong, durable, and possessing many special qualities of its own. It allows the opening of the pages perfectly flat, whether one or several numbers are in the binder. Any number can be taken out and replaced without disturbing the others. The papers are not mutilated for subsequent binding in permanent form. The binder is supplied with gilt side title, and is an ornament to any desk or reading table. The JOURNAL, filed in the Handy Binder, becomes a volume of great value, always convenient for instant reference. Handy Binder, Postage paid, \$1.00.

A. M. CALLENDER & CO., 42 Pine St., N. Y.

THE PENN GAS COAL CO.

OFFER THEIR

Coal, Carefully Screened & Prepared for Gas Purposes.

Their Property is located in the Youghiogheny Coal Basin, near Irwin and Penn Stations on the Pennsylvania Railroad, and on the Youghiogheny River.

Principal Office:

209 SOUTH THIRD STREET, PHILA., PA.

Points of Shipment:

Pennsylvania Railroad Piers; Greenwich Wharves, Delaware River; Pier No. 1 (Lower Side), South Amboy, N. J.

Chesapeake & Ohio Railway Coal Agency,

FOR THE SALE OF THE

Superior Kanawha Gas Coals, Cannelton Cannel, Also, SPLINT AND STEAM COALS,

From the Kanawha and New River Regions, on the line of the Chesapeake & Ohio R'way.

C. B. ORCUTT, Sales Agent. | OFFICE, 150 BROADWAY, N. Y.

FRANCIS H. JACKSON, Prest. EDMUND H. MCCULLOUGH, V.-Prest. CHAS. F. GODSHALL, Treas. H. C. ADAMS, Sec.

THE WESTMORELAND COAL CO.

Chartered 1854.

Mines situated on the Pennsylvania and the Baltimore and Ohio Railroads, in Westmoreland County, Penn.

POINTS OF SHIPMENT:

PHILADELPHIA, BALTIMORE, SOUTH AMBOY, N. J., WATKINS (SENECA LAKE), N. Y.

Since the commencement of operations by this Company its well-known Coal has been largely used by the Gas Companies of New England and the Middle States, and its character is established as having no superior in gas-giving qualities, and in freedom from sulphur and other impurities.

Principal Office, 224 South 3d St., Phila., Pa.

A. M. SCOTT, PRESIDENT. A. DEMPSTER, C.E., SECRETARY. W. K. GILLESPIE, TREASURER.

MONONGAHELA AND PETERS CREEK GAS COAL CO.,

PRODUCERS OF

Coal Bluff Gas Coal.

MINES LOCATED ON THE MONONGAHELA DIVISION OF THE PENNSYLVANIA RR., IN THE CENTRAL PORTION OF THE PITTSBURGH COAL FIELD.

Points of Shipment—Buffalo, Cleveland, Erie, Chicago, New Orleans.

Since the introduction of Coal Bluff Gas Coal it has taken rank among the few first-class Gas Coals, and acknowledges no superior in gas-giving qualities, ease of working, quality of coke, and freedom from impurities.

Milwaukee Agents, F. R. BUELL & CO., - - - Milwaukee, Wis.

General Office, 43 Sixth Ave., Pittsburgh, Pa.

GAS METERS.

GAS METERS.

GAS METERS.



INTERNATIONAL--1876--EXHIBITION.

The U. S. Centennial Commission

HAVE DECREED AN AWARD TO

HARRIS, GRIFFIN & CO.,

Twelfth and Brown Streets, Philadelphia, Pa. No. 49 Dey Street, N. Y. City, and No. 75 North Clinton Street, Chicago, Ill.

FOR THE FOLLOWING REASONS :

The Exhibit consists of a Series of METERS from the Largest Size Station Meters for the use of the MANUFACTURE OF GAS, to those for the use of the ORDINARY CONSUMER. The Instruments are WELL MADE, RELIABLE as to INDICATION, and embody a number of sundry improvements which, with the general character of the Exhibit, entitle the whole to commendation.

Attest—J. L. CAMPBELL,
Secretary, pro-tem

Signed—A. T. GOSHORN,
Director General

J. R. HAWLEY,
President

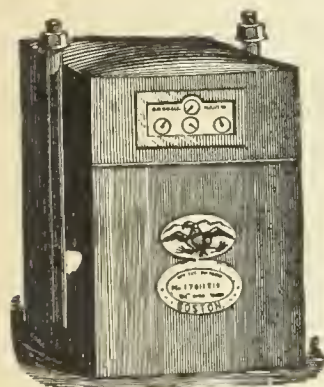

Dry Gas Meter.

With 39 years' experience and the best facilities for manufacturing, is enabled to furnish reliable work and answer orders promptly.

NATHANIEL TUFTS,

No 153 Franklin Street, Boston, Mass.,

MANUFACTURER OF

DRY GAS METERS.

Station Meters of any Capacity.

Test and Experimental Meters, Pressure Registers, Pressure Gauges.
Pressure and Vacuum Gauges.

METER PROVERS, PHOTOMETERS, STREET LANTERNS, ETC., ETC.

Patent Cluster Lanterns for Street Illumination.

SCIENTIFIC BOOKS.

We are prepared to furnish to Gas Managers, and others interested in the topics treated of, the following books, at prices named :

KING'S TREATISE ON THE MANUFACTURE OF COAL GAS. Three vols.; \$10 per vol.	PRACTICAL TREATISE ON HEAT, by THOMAS BOX. Second edition. \$5.	THE GAS MANAGER IN THE LABORATORY, by a Practical Student. 8vo., Cloth. \$1.50.
GAS MANUFACTURE, by WILLIAM RICHARDS. 4to., with numerous Engravings and Plates, in Cloth binding. \$12.	GAS WORKS—THEIR ARRANGEMENT, CONSTRUCTION, PLANT, AND MACHINERY. \$8.	THE DOMESTIC USES OF COAL GAS, AS APPLIED TO LIGHTING, by W. SUGG. \$1.40.
THE GAS ANALYST'S MANUAL, by F. W. HARTLEY. \$2.50.	COAL; ITS HISTORY AND USE, by PROF. THORPE. \$3.50.	DISTILLATION OF COAL TAR AND AMMONIACAL LIQUOR by GEO. LUNGE. \$8.50.
TECHNICAL GAS ANALYSIS. \$2.80.	THE GAS WORKS OF LONDON, by COLBURN. 60 cents.	A TREATISE ON THE COMPARATIVE COMMERCIAL VALUES OF GAS COALS AND CANNELS, by D. A. GRAHAM 8vo., Cloth. \$3.
GAS MANAGER'S HANDBOOK, by THOS. NEWBIGGING. \$4.80.	THE GAS FITTER'S GUIDE, Showing the Principles and Practice of Lighting with Coal Gas, by JOHN ELDREDGE. 40 cents.	GAS AS A SOURCE OF LIGHT, HEAT, AND POWER, by C. J. R. HUMPHREYS. 10 cents.
GAS CONSUMER'S GUIDE. \$1.	GAS WORKS, AND MANUFACTURING COAL GAS, HUGHES. \$2.20.	GAS COMPANIES DIRECTORY. \$10.
A GUIDE TO GAS LIGHTING. 40 cents.	THE MANAGEMENT OF SMALL GAS WORKS, by C. J. R. HUMPHREYS. \$1.	GAS VERSUS ELECTRIC LIGHT. 50 cents.
GAS MEASUREMENT AND GAS METER TESTING, by F. W. HARTLEY. \$1.60	MANUAL FOR GAS ENGINEERING STUDENTS, by D. LEE, 40 cents.	PURIFICATION OF COAL GAS, by R. P. SPICE. 8vo. \$3.
GAS CONSUMER'S HANDBOOK, by WILLIAM RICHARDS, C.E.; 18mo., Sewed. 20 cents.	HOW TO MANAGE GAS, by F. WILKINS. Paper. 20 cents.	
A PRACTICAL TREATISE ON GAS AND VENTILATION with Special Relation to Illuminating, Heating, and Cooking by Gas, by F. E. PERKINS. \$1.25.		

The above will be forwarded by express, upon receipt of price. We take especial pains in securing and forwarding any other Works that may be desired, upon receipt of order. All remittances should be made by check, draft, or post office money order.

A. M. CALLENDER & CO., No. 42 Pine Street, New York.

KING'S TREATISE ON COAL GAS.

The most complete work on Coal Gas ever published. Three vols., bound \$30

A. M. CALLENDER & CO., No. 42 Pine Street, New York.

GAS METERS.

GAS METERS.

GAS METERS.

GEO. J. McGOURKEY, Pres. WM. H. MoFADDEN, Vice-Pres. (Phila.) WM. N. MILSTED, Gen. Supt. & Treas. (New York). WM. H. DOWN Sec

AMERICAN METER COMPANY,

WET AND DRY GAS METERS.

PRESSURE REGISTERS.

METER PROVERS.

STATION METERS.

PRESSURE & VACUUM REGISTERS.

PORTABLE TEST METERS.

EXHAUSTER GOVERNORS.

PRESSURE & VACUUM GAUGES.

EXPERIMENTAL METERS.

DRY CENTRE VALVES.

CRESSON GAS REGULATORS.

AMMONIA TEST METERS.

GOVERNORS FOR GAS WORKS.

MARSLAND WATER METERS.

BAR AND JET PHOTOMETERS

Manufactories:

512 W. 22d St., N. Y.
Arch & 22d Sts., Phila.

GAS STOVES,

SUGG'S "STANDARD" ARGAND BURNERS,
SUGG'S ILLUMINATING POWER METER,
Wet Meters, with Lizar's "Invariable Measuring" Drum.

Agencies:

177 Elm Street, Cincinnati.
244 & 246 N. Wells Street, Chicago.
810 North Second Street, St. Louis
122 & 124 Sutter St., San Francisco.

HELME & McILHENNY,

(Successors to Harris & Brother. Established 1848)

GAS METER MANUFACTURERS,

CONTINUE AS HERETOFORE AT THE OLD ESTABLISHMENT.

Nos. 1339 to 1349 Cherry Street, Philadelphia, Pa.,

To Manufacture Wet and Dry Gas Meters, Station Meters, Experimental Meters, Meter Provers, Center Seals, Pressure Registers

GOVERNORS, INDICATORS, PHOTOMETERS, & ALL OTHER KINDS OF APPARATUS FOR USE IN GAS WORKS.

From our long practical experience of the business, and from our personal supervision of all work, we can guarantee all orders to be executed promptly and in every respect satisfactorily.

WM. WALLACE GOODWIN, Prest. and Treas.

WM. H. MERRICK, V.-Prest.

S. L. JONES, Sec.

S. V. MERRICK, Supt.

THE GOODWIN GAS STOVE AND METER COMPANY,

Successors to W. W. GOODWIN & CO.

1012, 1014 and 1016 Filbert St., Phila., Pa.

142 Chambers St., New York.

76 Dearborn St., Chicago, Ill.

WALDO BROS., Agents, 88 Water St., Boston.

MANUFACTURERS OF THE "SUN DIAL" GAS STOVES, FOR COOKING AND HEATING PURPOSES.

Dry and Wet GAS METERS, Station Meters (Square, Cylindrical or in Staves) Glazed Meters, King's and Sugg's Experimental Meter Post Meters, Etc., Etc., Meter Provers (sizes 2, 5 and 10 feet), Pressure Gauges of all kinds, Pressure Registers, Pressure and Vacuum Registers, Pressure Indicators (sizes 4 inch, 6 inch and 9 inch), King's Pressure and Vacuum Gauges, Dry and Wet Centre Seals, Dry and Wet Governors, Exhauster Governors, Photometers of all descriptions. Letheby's Sulphur and Ammonia Test Apparatus complete—also Testing and Chemical Apparatus of all kinds, and of the most perfect description, for all purposes relating to Gas.

GOODWIN'S IMPROVED LOWE'S JET PHOTOMETER.

Agents for Bray's Patent Gas Burners and Lanterns.

Special attention to repairs of Meters, and all apparatus connected with the business.

All work guaranteed first class in every particular, and orders filled promptly.

G. B. EDWARDS, Mang'r, New York.
E. H. B. TWINING, Mang'r, Chicago.
Represented by A. B. STANNARD.

D. McDONALD & CO.,

GAS METER MANUFACTURERS.

(Established 1854.)

51 Lancaster St., Albany, N. Y. 34 & 36 West Monroe St., Chicago, Ill.

STATION METERS, EXPERIMENTAL METERS, METER PROVERS, PRESSURE & VACUUM REGISTERS, PRESSURE GAUGES, ETC.

Also STAR GAS STOVES, RANGES, and HEATING STOVES.

We use only the very best materials, and employ the most skilled labor, and by our long experience (32 years) and personal supervision of every detail, we feel justified in assuring the public that our goods will give perfect satisfaction. Every Meter emanating from our establishment will bear the State Inspector's Badge, and will be fully warranted by us. Our Annual and Calendar will be sent to Gas Companies upon application.

GAS STOVES.

GAS STOVES.

GAS STOVES.

THE GOODWIN GAS STOVE AND METER CO.,

1012-18 Filbert St., Phila., 142 Chambers St., N. Y., 76 Dearborn St., Chicago.

Agents, WALDO BROTHERS, 88 Water Street, Boston.

WM. W. GOODWIN, PRES. & TREAS.
W. H. MERRICK, VICE-PRES.
LEWIS JONES, SEC.
SAMUEL V. MERRICK, SUPT.

SOLE MANUFACTURERS OF THE

G. B. EDWARDS, Mang'r, N. Y.
E. H. B. TWINING, Mang'r, Chicago.
Represented by A. B. STANNARD.

"SUN DIAL" GAS STOVES

The Most Economical, Efficient, and Durable Gas Stove Made.

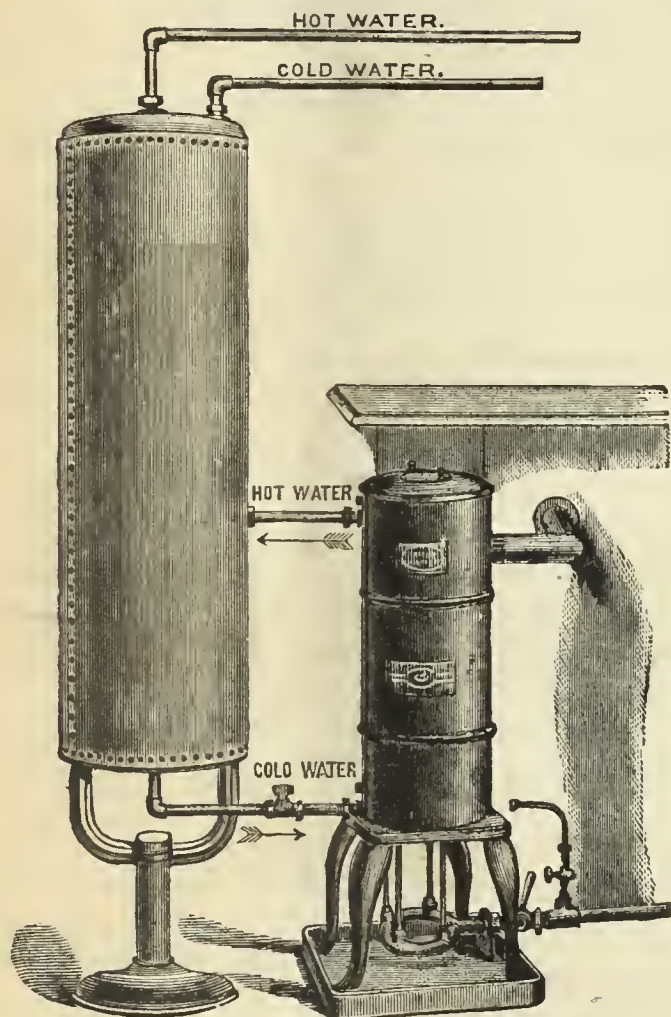

I.—Safety Hot Water Generator and Boiler.

Safety Hot Water Generator and Boiler.

Cut I. represents our Safety Gas Hot Water Generator and Boiler, arranged for home use. This most easy, quick, and economical way of preparing a warm bath, or for heating water for any domestic purpose, entirely supersedes any necessity for the use of ranges or stoves—a great comfort, particularly in hot weather. The boiler being self-filling, as the hot water is drawn off, can never become empty, thus preventing the possibility of any accident.

We beg to call attention to the cast iron pan which is now attached to the legs of the Generator (see illustration). This is to catch the drippings from the coil, which many persons suppose come from a leak, when in fact they are produced by condensation. This condensation is caused by the hot flame coming in contact with the coil filled with cold water.

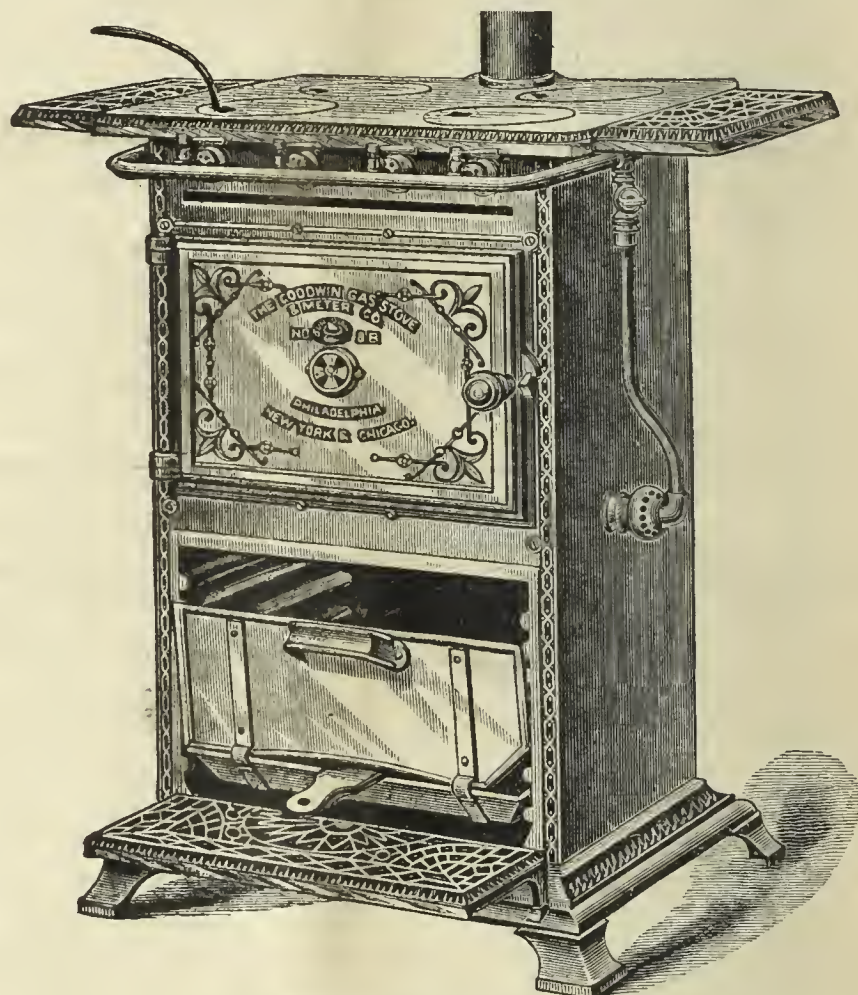

II.—Gas Cooking Stove No. 8 B.

New Style Gas Cooking Stove.

Cut II. represents our New Style Cooking Stove. As will be seen, it has an ornamented cast iron base and front, and extension shelves. The oven burner, which is atmospheric (unless otherwise ordered), is of an entirely new and improved pattern (patent applied for). The ovens are of greater capacity than those of the old style. The top, in conjunction with the outlet pipe, is designed to carry off all products of combustion; hence the outlet pipe must be connected with a flue, or the stove will not work properly.

This Stove has 4 boiling burners in top of hot plate. All fittings are nickel plated. We are making this style of Cooking Stove in the following sizes—viz., No. 7 B, No. 8 B, No. 9 B, and No. 10 B.

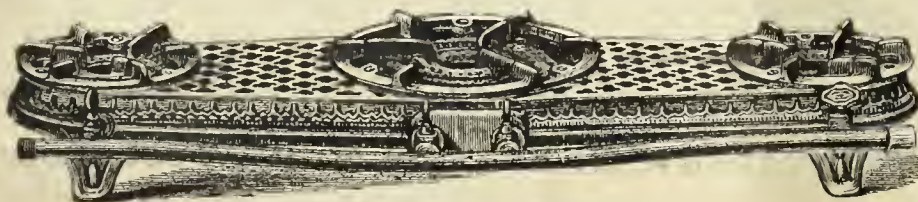

III.—Improved Hot Plate, No. 108.

New Style Hot Plates.

Cut II. represents our New Style of Hot Plates, of which we are making No. 106 (two small boiling burners), No. 107 (two medium sized boiling burners), and No. 108 (two medium and one large boiling burner). See new Catalogue and Price List for further particulars.

THE AMERICAN

GAS LIGHT JOURNAL

REDMAN & KENNY, N. Y.

PUBLISHING OFFICE No. 42 PINE STREET

DEVOTED TO THE INTERESTS OF ILLUMINATION, VENTILATION, WATER SUPPLY AND DISTRIBUTION, & GENERAL SCIENCE.

VOLUME XLVI.—No. 12. }
Whole No. 672.

NEW YORK, THURSDAY, JUNE 16, 1887.

{ \$3 PER ANNUM,
IN ADVANCE.

A. M. CALLENDER & CO., Proprietors. C. E. SANDERSON, Manager.
JOS. R. THOMAS, C. E., Editor. T. J. CUNNINGHAM, Asst. Editor.

ENTERED AT THE POST OFFICE AT NEW YORK, N. Y.
AS SECOND CLASS MATTER.

Published on the 2d and 16th of each month, at No. 42 Pine Street, N. Y.

Terms of Subscription, Including Postage.—For the United States and Canada, \$3 per annum. European countries, \$3.50 (15 shillings—18 francs). All payments to be made in advance. Single copies, 15 cents.

Remittances should be made either by post-office order, registered letter, or bank draft on New York, payable to the order of A. M. Callender & Co.

Correspondence.—Wishing to make this JOURNAL a gazette of intelligent discussion to those of our readers who may wish to gain or give information on the subjects to which its columns are devoted, correspondence is solicited for publication from all who make the study of those subjects a pleasure or a profession.

The American News Company, Nos. 39 and 41 Chambers street, New York, are agents for this JOURNAL. Newsdealers will send orders to them.

Collections are invariably made directly from this office, for subscriptions, advertisements, etc. We have agents to solicit the same, but they are not authorized to receipt for money.

Books.—We will forward by express, at publisher's lowest rates, any book—scientific or otherwise—to any address in the United States or Canada. No books will be sent C. O. D.

CONTENTS.

An Asterisk (*) denotes an illustrated article.

EDITORIALS—

A Fraternal Token from Across the Sea.....	373
Editor Stone and the Gas Companies.....	374
In Regard to the Distribution of Fuel Gas in Troy, N. Y.....	374
Rules for Testing Gas Fittings.....	374
Tenth Annual Meeting of the Western Gas Association—Official Report—Continued from page 348.....	375
Concluding the Discussion on Mr. Egner's Paper—In Memoriam Resolutions—First Day, Afternoon Session—New Members Elected—Appointment of Special Committees—Report of Committee on President's Address—Report of Directors on Application to Report the Proceedings—The Distillation of Coal, by J. Gimper—Discussion—Gas from Lime Stone—Assigning Subjects for Papers.	
* The Waterhouse System of Electric Lighting.....	380
The Cincinnati (Ohio) Gas Light Company vs. Chas. J. Steinau....	381
Action of Oil on Metals.....	382

ITEMS OF INTEREST FROM VARIOUS LOCALITIES.....

Capital Increase—Mr. Frost Goes to Baltimore, Md.—Electric Light for Worcester, Mass.—Public Lighting at Toronto, Can.—Coming Down at Providence, R. I.—A Gas Machine Company for the Golden State—Taking Formal Possession—There's Nothing in It—Dr. Cabot Goes to Europe—A Gas Thief Punished—A Correction—Annual Election, Kansas City, Mo.—Accepted and Authorized—Favorable to the System—Cheaper Gas for Cedar Rapids, Iowa—Proposals for Gas Lamps and Pillars—Chartered in Gilpin County, Col.—The Authorities in a Huff—Annual Election, Georgetown, D. C.—The Findlay (O.) Natural Gas Celebration—Rochester (N. Y.) to be Lighted by Electricity—Brother Trumbore Says Good-by—Patent Issued to Geo. H. Gregory—Tried by Fire—Facts for the Lawyers—The General Takes a Hand-in—To Reorganize—Western Waifs, by "Diaphragm"—The Incorporators—The Mills' Lime Tray—Will They Tire Out Brother Cressler?—Completion of the Charlestown (Mass.) Gas Company's Electric Plant—Hempstead (L. I.) Matters—Ousted.

CORRESPONDENCE—

Mr. Wells Gives Reasons for His Belief.....	385
A Righteous Decision.....	385
The Market for Gas Securities.....	386

A FRATERNAL TOKEN FROM ACROSS THE SEA.

One of the most pleasing circumstances connected with the business of the gas maker is that evidenced by the feeling of kinship which binds the real working members of the profession, so to speak, in a joint brotherhood. The Yankee gas engineer, should his opportunity for travel enable him to compass the distance between the States and Tokio, for instance, having made himself known to his confrere at the last-named and distant spot, could feel assured of being greeted by a welcome "with feeling, not with fashion, softly freighted," and thus experience that contact of fellowship so refreshing to the sojourner, willing one though he be, in a foreign land. As it is in the Tokio instance, so also is it in quarters nearer home, and while gas men, of course, can and do appreciate fair skies and smooth waters, the roughnesses of adversity are powerless to disturb the serenity of their brotherhood and kinship. Thus prelude an instance which is submitted to prove the truth of that which we have set forth above, we herewith submit the salient points of a letter, the publication of which will reveal the spirit that prompted its composer:

"ROSEMONT FERRY ROAD, EDINBURGH, SCOTLAND, May 23, 1887.

"To the Editor AMERICAN GAS LIGHT JOURNAL:—Dear Sir—Will you kindly favor me by accepting the inclosed draft for five guineas, which I venture to send you, with the request that you will apply it to any of your Associations of Gas Managers, or in such other way as you may think best for promoting the objects of the American Gas Managers, whose interests you have so well represented for so many years. * * *

"It is some years since I went out of harness as a gas engineer, and it is fully 45 years since I first donned it in that capacity. I find that the last few years have left me far behind the advances that have been made, and I can only indicate by the inclosed my best acknowledgment of the teachings of your JOURNAL, which, I may tell you, I always enjoy. * * *

"If you please you need not mention my name, but in the place thereof perhaps the following *nom de plume* will do as well. Kindly let me know if this reaches you all right. Yours very truly,

"AN OLD SCOTTISH CONTRIBUTOR."

We believe that this unaffected and fraternal communication will be pleasant reading for our American fraternity, and we herewith, on their behalf, accept "An Old Scottish Contributor's" offering in the same spirit that caused him to forward it. To formally thank him now would not strengthen or illustrate our pleasure at his fraternal action, so we may pass on to say how we think it best to dispose of the guineas. Having consulted with some of those in authority in the executive management of the American Gas Light Association, it was thought best to offer the money remitted as a prize to be awarded to the author who contributed the best paper to be read at the forthcoming meeting of the American Gas Light Association. Further than this general disposition of the prize we feel it is not our province to explain, other than we presume that the officers of the Association will take upon themselves the duty of determining the way and means to secure a verdict in regard to which paper presented is best entitled to an award of the prize.

In connection with the matter of securing papers to be read at the coming meeting of the American Association perhaps no great harm will

arise did we call attention anew to the action taken in regard to the premises at the Philadelphia meeting, last October. Hitherto the Secretary has been solely burdened with the somewhat unpleasant and decidedly laborious task of importuning members for literary contributions, but hereafter, or until otherwise ordered at least, an entirely different method is to prevail. As the date for putting the new process in operation is really now at hand, we take occasion to reproduce the resolution commanding the new departure. That resolution is as follows:

"Resolved, That the Executive Committee be, and is hereby instructed to make a selection of, or designate not less than five members of this Association, who shall be requested, by said Executive Committee, to prepare papers upon subjects to be either selected or approved by the Committee; that the persons designated to prepare papers shall be notified of their selection, and of the subjects upon which they are expected to write, not less than 90 days before the date of the next annual meeting."

A reference to the intervening days shows that if the *spirit*, as well as the letter, of this resolution is to be carried out the Executive Committee have not much time for delay in instituting the preliminary steps necessary to insure a successful issue.

EDITOR STONE AND THE GAS COMPANIES.

Editor Stone, who guides the *New York Journal of Commerce* in such deft and skillful manner amid the mazy paths of the pen and ink chronicles of the world's markets, must have a wicked partner, for when the real editor is not recounting the state of trade he is employed in coaxing to maturity and flower, either in sun-swept external garden bed or beneath the sheltering cover of the greenhouse, choice specimens of nature's plants and shrubs and vines. In view of his passion for that most peaceful of delights—the gardener's art—we cannot believe that Editor Stone would be wilfully unjust, therefore do we opine that it is to the pen of his wicked partner must be laid those fierce attacks upon the gas men that now and then inflame the otherwise placid columns of the *Journal of Commerce*. If the wicked partner is the one really responsible for the onslaughts—which, as a rule, often approach in dangerous proximity to truculency—we hope that his chief will seek to show him the error of his way. A correspondent in considering the attitude of the *Journal of Commerce* towards the local gas suppliers, calls attention to the following facts (if Editor Stone would *only* weigh them carefully), a perusal of which might even convert the wicked partner:

"The *Journal of Commerce* is now printed on paper that costs four cents per pound, whereas formerly its cost was nineteen cents per pound, nevertheless the subscription price of the aforesaid *Journal* remains the same. The par value of a share in the *Journal of Commerce* is \$1,000; but these shares would now sell at \$10,000. Would it not be well, at the next meeting of the Legislature, to introduce a bill that would provide for a compulsory reduction in the subscription price of the *Journal of Commerce*?"

Perhaps it would; it would certainly be beneficial to those merchants who peruse its columns every day. We fear, though, that Editor Stone and the wicked partner might scent an odor of communism in the proposition, and be prepared to stoutly resist such a diversion and division of the unearned increment.

In Regard to the Distribution of Fuel Gas in Troy, N. Y.

During the time of greatest indignation aroused by the fuel gas disaster, that occurred in Troy, N. Y., on date of Jan. 16, on which occasion three persons lost their lives and many others were seriously prostrated, the Common Council, at a special session, suspended the fuel gas company's franchise, and subsequently appointed a special committee of five of their number, who were directed to inquire "into the condition of safety of the plant of the company, and to ascertain if the manufacture and distribution of non-illuminating fuel gas can be proceeded with within the city limits without endangering the health and lives of the inhabitants." That committee, having made an exhaustive investigation of the subject, recently presented to the Common Council the following report and recommendations:

"The Committee report that they have thoroughly investigated the matter, and find that to regulate the use of illuminating and fuel gas for the better protection of life and property, it will be necessary for your Board to adopt an ordinance setting forth, in unmistakable language, the city's requirements of parties engaged in the manufacture and distribution of illuminating and fuel gas. And your Committee would recommend the following as the substance of the proposed ordinance:

"SEC. 1. No person, company or corporation shall manufacture or have in this city, or deal in, keep, sell or give away, for illuminating or heating purposes, gas, except under the conditions hereinafter prescribed.

"(a.) The main pipes shall be laid at such depth as shall be directed by the board of health, not less than 3 feet from the surface, and shall be the best of iron pipe, with joints so arranged as to prevent leakage of gas; said mains, pipes and joints to be so laid as to stand a pressure of not less than five times the pressure under which the gas is to be delivered to consumers.

"(b.) All house connections, piping, fixtures and joints shall be so constructed as to stand a pressure of not less than five times the pressure under which the gas is to be delivered to consumers.

"(c.) No gas shall be put into the mains, pipes or house pipes until said mains, pipes or house pipes shall have first been properly inspected and tested and pronounced to be satisfactory by a person competent to make said inspections and tests.

"(d.) Whenever such mains or pipes or extension of mains or pipes, or house connections, or piping are to be laid, the company laying the same shall first notify the board of health, in order that its approval may be secured, of a competent person for thoroughly inspecting and testing the same, and the cost of such inspecting and testing, and all expenses connected therewith shall be defrayed by the company.

"SEC. 3. No gas of any kind, whether used for illuminating or heating purposes, shall be permitted in the city of Troy, unless it be so charged with a strong odorant that its slightest escape may be easily detected, and anyone manufacturing or dealing in such gas without such odorant as is herein prescribed, and without complying with the conditions laid down in sections one and two of this ordinance shall be subject to the suspension of all his or their franchise rights.

"Your Committee would also report that the State Board of Health has recommended the passage of a general law for the State similar to the above proposed ordinance." [Signed by the committee.]

The regulations are all very good, as far as they go; but it would seem as if the Trojans, after their midwinter experience, might reasonably demand still further protection.

Rules for Testing Gas Fittings.

The *London Journal*, in commenting editorially upon the list of rules formulated by the Fire Marshal, of Pittsburgh, Pa. (that official having acted in the premises at the instigation of the local Board of Underwriters), to be observed in the piping of houses in which natural gas is to be employed for domestic purposes, thinks that these rules "may be usefully noted by inspectors of coal gas fittings at home." After that preliminary hint our contemporary says, "It is ordered that all fittings, before being used for gas, shall be inspected by an official, who is to be called in by the fitter to pass his work. All pipes must be tested by an air pump to a pressure of ten pounds, as indicated by a mercury column. All pipe ends are capped at first to allow the cocks to be tested, and then the caps are removed and the cocks tested for leakage. In case the pressure drops, a test with ether or with soapy water is ordered. No fire test is permitted under any circumstances. If a fitter should attempt to hide a leak, or to use cement for stopping a cracked pipe, his name is recorded in a black list for particular attention on a future occasion. It is necessary to be very careful in piping for natural gas, because it has but a very slight odor; and the safeguard, in the case of coal gas, is consequently removed.

"A vast amount of careless work in gas fitting is done in England because there is no inspection whatever in the majority of cases. It is, of course, open to an advocate of what is called Individualism to claim that, on the whole, there are not more explosions and fires due to faulty fittings where gas fitters are allowed a free hand than there are in towns where rigid inspection is the rule.

"The worst aspect of inspection systems unquestionably is the difficulty of insuring that rules are rigidly conformed to in all cases; and there is also the disadvantage that personal responsibility is divided between the inspector and the fitter, instead of being concentrated upon the latter. Human nature is not peculiar to gas fitters, moreover, and the average man, if he is treated as being unfit for responsibility, is prone to justify the suspicion; while with some workmen the temptation to try to circumvent an inspector whom they dislike is almost irresistible.

"This is a rather large subject, however, to be discussed on a point of rules for fire prevention. Regarded as regulations, these of the Pittsburgh Fire Marshal are decidedly reasonable and sufficient, without at all erring on the side of over-elaboration."

[OFFICIAL REPORT.—Continued from page 348.]

Tenth Annual Meeting of the Western Gas Association.

HELD AT ST. LOUIS, MO., MAY 11, 12 AND 13, 1887.

FIRST DAY—MORNING SESSION—MAY 11.

Concluding the Discussion on Mr. Egner's Paper.

Mr. Howard—I heartily indorse the plan proposed by Mr. Egner. I believe it would be a good thing for the fraternity at large. Many questions of interest have not been definitely settled, and I believe that if such questions could be investigated by a body of men like those sure to be selected to govern the institute, their reports would be of lasting value. Take, for instance, the purification of gas; some prefer oxide to lime, while others favor lime. If a competent authority investigated that matter thoroughly, the results could be relied upon by every company; and so it would be in other instances. As far as the defensive feature is concerned, I do not think that would be of much value, for if you take into consideration the present scale of consolidation going on, and thus realize the number of companies that are being either gobbled or bought up, you can readily see that in a few years not many companies will be at all interested in paying assessments to prevent raiding. I know in Iowa we are interested especially in that feature at the present time; but we calculate to fight the battle out on the right line, and expect to come out victors in the end. As my friend, Harbison, says, there are no secrets now in the gas profession; but I well remember when the greatest secrecy was observed. I remember the time when the engineer of a certain works prohibited a workman from examining a center seal that was about to be put up in the works. The workman asked if he could look it over before it was placed in position. "Oh, no," was the reply, "you cannot look at that; that is a great secret of mine." Now, however, a gas man is happiest when he can convey a bit of information to his brethren. I hope something will be done by this Association with regard to the proposed institute.

The President—I call upon Mr. Sherman, of New Haven, Conn., to speak to us on this subject.

Mr. Sherman—As I understand Mr. Egner's paper, he proposes to establish an institute which shall investigate new processes and appliances, and give to its members the benefit of that investigation—a plan which I most heartily favor. During my long years in the gas business I can recollect the failure of many a device. Were I to attempt, in my own experience, to recall all the failures made by me, and which have cost the companies I worked for many thousands of dollars, I would be appalled. If we could apply to such an institute for information in regard to any new process or invention brought before us, it would save our companies thousands of dollars each year. There is room for difference of opinion as to whether we should support each other in our efforts to break down and overthrow raiders; but I do not see how there can be any honest difference of opinion with regard to the merit of the point so ably brought out by Mr. Egner. It would save every company (particularly the small companies which cannot afford to make these experiments) a large sum of money. I have known young engineers to lose their positions because of their making experiments. If they had a source of information similar to that outlined, much money would have been saved, and the engineers would have saved their reputations. I fail to see where there could be any valid objection to that part of Mr. Egner's scheme, even though there might be objection to the part which proposes to grant assistance to those in trouble from raids. The first inception of the American Gas Light Association (in May, 1874) arose from that very purpose—to see if the companies would not stand by each other against raiders. The feeling was so bitter against the plan that the Association had like to be strangled in the hour of its birth. Whether such an arrangement would or would not be wise, I am not prepared to say; but my views with regard to the other suggestions of Mr. Egner are very firm.

Mr. Scofield—I heartily approve of carrying out this plan. The remarks of my friend Harbison rather amused me; to think that he must come here, away out in our Western wilds, to learn anything from these Western gas men! It rather pleased me to have him express himself in that way, because some of us do not think that we know very much, and we look constantly toward the East for information. But since the "star of empire" moves westward, our friend Harbison comes here; therefore we are happy to meet and welcome him, are glad to avail ourselves of his experience, and to partake of his knowledge. Asking to be excused for the digression, I may say that prior to listening to Mr. Egner's paper I had not known that this subject had been brought before any other Association, and it seemed to me a matter of much importance. Still, can such a plan be consummated? It would undoubtedly prove of

great benefit to every little Western gas company, and often would be of equal benefit to the larger ones. Of course we are raided upon by the owners of almost every new patent, and if we could have the value of these new things satisfactorily determined by careful and proper test, made by competent experts in our own employ, much of our annoyance and loss would be permanently disposed of.

Mr. Watts—I think the institute would have plenty to do for many a day in investigating the different branches of our processes and machinery, as these are at present followed, without going into anything new.

Mr. Coverdale—As I understand it, this committee is ordered to report to-morrow.

The President—Yes; on the plan to be adopted.

Mr. Coverdale—And I suppose that further discussion will be permitted when the report of the committee comes before the meeting.

The President—Of course, as I understand it, this committee will report to-morrow upon some plan to be adopted. That plan will then be referred to the other Associations, and if generally approved of by these other Associations, then a set method of action can be agreed upon for the establishment of the institute.

Mr. Thomas—I would like to further say that in my opinion this institute would supply much knowledge essential to the companies, and that it would be obtained most cheaply. By the way, our friend Harbison said that what we learn ought to be given freely. So it should be; but, nevertheless, what a man learns is a part of his capital, and he expects a dividend on it.

[At this point Mr. G. S. Page entered the room, and was invited by the President to give his views on the subject. The President and Mr. Egner explained briefly the substance of the paper that had given rise to the discussion, and also mentioned that the special committee in charge of the matter would report thereon on the following day. Mr. Page thereupon said he would reserve any expression about it until the report had been read.]

On motion of Mr. Cosgrove, a vote of thanks was passed to Mr. Egner.

IN MEMORIAM RESOLUTIONS.

Mr. Thompson, of Committee on Memorial Resolutions, read the following report:

WHEREAS, This Association having learned with deep regret of the death of our late associate, and first President, the late Mr. J. O. King, of Jacksonville, Ills.,

Resolved, That by the death of Mr. King this body has lost one of its most prominent and honored members; one to whom, more than to any other, we are indebted for the organization and subsequent prosperity of our Association. He was, in fact, the man to first conceive the formation of this Association, the consummation of which project is due principally to his efforts. His ability in his profession was recognized by us all, while his untiring activity in behalf of our Association, and the views held by him as expressed in our meetings, have impressed us with the sincerity of his aims in furthering the interests and promoting the objects of our organization.

Resolved, That by our intercourse with the deceased we learned to respect him for his ability, purity, and geniality; and,

Resolved, That his death deprived us of a man who was a credit to himself and an honor to the gas fraternity.

J. D. THOMPSON, }
J. B. HOWARD, } Committee.
T. A. COSGROVE, }

The resolutions were, on motion of Mr. Lansden, adopted by a rising vote, and ordered to be spread on the minutes of the Association.

A recess was now ordered.

FIRST DAY—AFTERNOON SESSION.

Business was resumed at 2:30 P.M., by the election of the following named applicants for membership:

NEW MEMBERS ELECTED.

Adams, C. F., Chicago, Ills.	Brown, E. C., Philadelphia, Pa.
Butterworth, W. C., Rockford, Ills.	Boardman, A. E., Macon, Ga.
Carver, W. L., Carthage, Mo.	Childs, J. C., Rome, Ga.
Castlen, W. A., Chicago, Ills.	Dunlap, H., Emporia, Kas.
Dickey, G. S., Chicago, Ills.	Frost, E. J., St. Paul, Minn.
Fishback, L. M., St. Louis, Mo.	Huston, J. N., Connersville, Ind.
Hill, J. D., Fort Scott, Kas.	Hopper, W. H., Philadelphia, Pa.
Hess, C. E., Jefferson City, Mo.	Leefers, J. H., Shelbyville, Ind.
McMillin, F. E., Neb. City, Neb.	Powell, A. W., St. Louis, Mo.
Ransom, N. A., Chicago, Ills.	Reynolds, B. S., Louisiana, Mo.
Rappleye, N. B., Chicago, Ills.	Rogers, E. D., Fort Wayne, Ind.
Steinwedell, Wm., Quincy, Ills.	Soden, W. T., Emporia, Kas.

Shores, L. W., Kankakee, Ills. Scott, H. C., St. Louis, Mo.
 Stratton, J. W., Valparaiso, Ind. Stratton, S. S., Chicago, Ills.
 Tracy, Wm., Peru, Ind. Veal, E., Boonville, Mo.
 Woolen, A. L., Franklin, Ind. Walsh, R. D., St. Louis, Mo.

APPOINTMENT OF SPECIAL COMMITTEES.

The President appointed the following special committees :

Nominating Committee.—Messrs. E. H. Jenkins, B. E. Chollar, J. Gimper, L. K. Scofield, and A. H. Barret.

Committee on Place of Meeting.—Messrs. T. A. Cosgrove, C. M. Keller, and G. H. Tayler.

REPORT OF COMMITTEE ON PRESIDENT'S ADDRESS.

Mr. E. McMillin, from Committee of reference on President's Address, read the following report :

Gentlemen:—Your Committee appointed to take into consideration the President's Address, and to report to this Society such suggestions as they may think should be further considered by you, respectfully submit that in their opinion the address is sufficiently clear and explicit to need no further elucidation by the Committee.

Your Committee suggest that it would be well for the members to carefully read the address, when published in the regular proceedings, and profit by the thoughts suggested.

There is one assertion, however, in the address that your Committee believe the Association would be interested in having further discussed, which is, that it costs more to enrich natural gas than to make coal gas.

The President very forcibly calls attention to the benefits that grow out of this Association, and this leads your Committee to suggest to the members that additional benefits may be derived from State organizations of a similar character.

Your Committee also suggest that this Association put itself on record as believing that the time is rapidly approaching when State Gas Commissions will be found beneficial both to gas companies and their patrons.

Respectfully submitted,

E. McMILLIN, }
 J. B. HOWARD, } Committee.
 E. J. KING, }

Ordered to be placed on file.

REPORT OF DIRECTORS ON APPLICATION TO REPORT THE PROCEEDINGS.

The Board of Directors, to whom was referred the application* of Mr. G. W. Graeff, Jr., reported that "We recommend that the AMERICAN GAS LIGHT JOURNAL be continued as the official organ of the Western Gas Association, and such other journals as may desire to print the proceedings be accorded that facility for taking stenographic or other notes of all proceedings and papers that would not interfere with the business of the Association."

The report was discussed at some length, and before the question on its adoption was put, the President, in explanation, said that the report retained the AMERICAN GAS LIGHT JOURNAL in its position as the Association's official organ, and in which the proceedings are to be regularly published, in respect to papers, discussions, etc. In answer to a question for a further construction of the report, President Fullagar said :

"I rule that whatever papers are read before the Association be turned over by the Secretary to the AMERICAN GAS LIGHT JOURNAL. If members wish to give copies of their papers to other journals, that is the affair of the authors."

The report was adopted.

READING THE PAPERS.

The following paper, by Mr. J. Gimper, of Leavenworth, Kansas, on
 THE DISTILLATION OF COAL,
 was now read :

Cheaper gas has been the constant cry during all my experience in gas making, and this cry has met with a corresponding response. The gas man has not remained idle, for he has made improvements in almost all of the different departments; but in no other one has so much progress been made as in that part where some kind of regenerative system of firing has been adopted. Admitting that progress in the instance specified, I am of the opinion that much more can be accomplished by the proper distillation of the coal, for our present mode of distilling the coal is about the same as it has been from the beginning of the history of gas making. Let us look at it for a few moments carefully in order to see what we are doing.

We introduce solid coal into a highly heated retort, and while we thus volatilize a portion of it, yet another portion is but partially volatilized, although, in the very next moment, we commence to condense it again.

This was most forcibly illustrated to me by a mouthpiece in one of our benches which had a crack in its bottom. One day, after charging a retort, I noticed, in less than five minutes after closing the lid, a small stream of water running from the crack, which, continuing for some time, conclusively showed what a strong condenser the mouthpiece and stand-pipe is. Choked stand-pipes are also a further clear indication of this fact.

These are, to my mind, erroneous conditions. We should not commence condensation at the end of the retort. We should continue to prolong the distillation until all the semi-volatilized parts, or tar, has also been fully converted into a permanent gas. In other words, we should produce gas and coke only, and make no tar. That this can be done none of you can deny. The only question is, "Is it practical; and will it pay?" In answer to both portions of the question I would say that I firmly believe it is practical, and hence can be made to pay. In fact, when so done, the question of dollar gas will have been solved.

In order to accomplish such results we must inclose our mouthpiece or have none at all; also the stand-pipes should be protected, the volatilized products of the coal should be passed through heated retorts, or chambers, where all the tar would become fixed into permanent gas, and thence led to the hydraulic main. As a result of this practice, I believe we would secure a gain of from 1 to 1½ cubic feet of gas per pound of coal carbonized.

Those heated retorts or chambers might form a part of the arch, and need not be exposed to the highest heats in the arch.

To convince myself of the correctness of this line of thought I have made some experiments—the apparatus for which, however, while not purposely constructed for the end suggested, nevertheless served or answered to prove the possibility of easy conversion of all the tar into gas.

I had three through retorts which were connected with each other and set one over the other. All the retorts were provided with sight-cocks. The lower retort was charged with coal, and observations made on all the retorts, which showed the following conditions. The lower retort remained clear to sight for ten minutes, looking from the back end of the charge towards the first rising pipe; the middle and top retort darkened at once, with a dense smoke. On allowing this smoke to escape it was noticed that it possessed a bluish tinge, and quite unlike the yellowish brown (and thick) color so well known to you all. When this smoke was allowed to impinge against a colder object moisture and fine carbon would be deposited upon the surface, but no tar.

This condition continued for 45 minutes, regularly, during each trial after which the gas would become dry, and no moisture could be detected. During all this time the retorts would have a dark or even blackish appearance, but as soon as the moisture had disappeared the interior of the retort began to show brighter, which brightness increased with every 10 to 15 minutes, until we could nearly see from end to end of retort. When the gas was allowed to escape it appeared as a blue smoke, and when in contact with a colder body would deposit only finely divided dry carbon, but no tar. When a pipe was introduced into the retort a like condition would be observed upon withdrawing it; it was absolutely free from any tar. The retorts were connected with a separate hydraulic main, and the tar-pipe leading from it was conducted to an open barrel, so that all the condensation from it could be observed; but no tar was visible during any of the trials. With remarkable regularity the 45 minutes were observed, during all the trials, for driving out the moisture. After one hour 30 minutes, to one hour 45 minutes, all the gas worth anything would be taken off. Hardly any smoke was then visible upon opening a sight-cock.

My apparatus beyond the hydraulic main was so connected that I could not measure or separate the gas to know its quality or quantity; but upon lighting it I could observe that it was fully as good as other gas extracted from the same coal under ordinary conditions. In fact, I believe, that with the proper sort of construction, a yield of from 6 to 6½ feet of gas per pound of coal can be obtained.

Discussion.

Mr. Howard—I was very much interested while listening to Mr. Gimper's paper. While not conversant at the time with the process or measures taken to gain the present results reported by Mr. Gimper, I do know that similar experiments were made, at a cost of several thousand dollars, too, in the Citizens gas works, at Brooklyn, N. Y., some 20 odd years ago, whose managers then thought they could not only volatilize the tar, but everything else as well, or to the complete volatilization of all the residuals. After repeated efforts, extending through a trial of two or three months, they failed to obtain the anticipated results, and abandoned the project. I think some of the older gas men here will remember the process, which was, I believe, known as the Elmer process.

**Ante*, p. 344.

The President—Was not that the Gwynne-Harris process?

Mr. Howard—No; it was the Elmer. I visited the Citizens' works at the time the experiments were being made. The plan, however, was a failure. I am proud to think that one of our Western men has achieved at result, although only in an experimental way. Nevertheless the success of the experiment leads me to believe that an equal or superior effect will be gained further on in a practical manner.

Mr. Egner—I believe I can eclipse Mr. Gimper's 6½ feet claim, for I have made 8 feet to the pound (having 14½-candle power) out of a coking coal mined in Washington county, Indiana. I tried that coal in another experimental apparatus, and got 8 feet of a splendid gas, but in 10 hours "fixed up" my exhauster to the degree that I could not get it to pass one cubic foot. I had to take that exhauster down and "chisel" it out; when I went to work again and secured a yield of 8 feet once more. I believe that more gas can be gotten out of the coal, and believe that rough light oils can be converted into gas to do what Mr. Gimper aims.

Mr. Lansden—I suppose this question relates to the same thing that I have been working on for several years past. It always puzzled me to know why it was that in the first hour or so of a charge I got 20 or 22 candle power gas from the retort, while at the end of 4 hours the candle power was down to 10 or 11. I always believed that the material in the interior of a lump of coal was just as good for gas making as the outside, and always understood that the tar contained a large quantity of valuable illuminants. A few years ago I made an experiment and secured results which beat Mr. Egner's all to pieces. I employed an upright retort, and fed pulverized coal into it, consequently the gas as it was generated passed through no incandescent carbon. I actually got 22 cubic feet of 16-candle gas to the pound of pulverized material. To make my meaning clear in this case: Suppose my lump to be a lump of coal; from the outside of it, early in the burning off, I get 20 to 22-candle gas; when the charge has worked for 1 to 1½ hours the candle power is down to 18, and finally this value lowers so that when the gas given out from the center of the lump is received it has a value of but 10 or 11 candles. Now, if you break that chunk of coal open you will find that there is just as good gas in its center as there was in its outside crust. I claim that the defect of our present system of carbonizing is this: As the outside of the lump of coal becomes incandescent, the rich gas passing from the center passes through this incandescent crust and carbon is deposited, while the hydrogen passes on through. Therefore, if we can carbonize the center of the coal without obliging the gas to pass through an incandescent crust, I believe that we might get 12 feet to the pound.

Mr. Gimper—In my paper I meant to point out more particularly the error that we commit in condensing too soon after we make the gas, and did not intend to lay so much stress on the great quantity of gas that we obtain per pound. I obtained my yield of 6½ feet to the pound from poor coal—not from such coal as most of you are accustomed to working with, and I might even have beaten Mr. Egner had I used a better grade; but as I am using a "nutty" coal my figures, of course, were based upon the materials I employed. It seems to me to be an error to condense immediately after making the gas. I have been troubled a great deal (when running very high heats) with tar, and I thought if I could get rid of the tar entirely—in fact make gas of it—it would be of great advantage. I tried to reach that result, and was very much interested in the trials. I could watch and see everything going on in the retorts as long as they were dry; but as soon as any moisture came from the coal the vista became absolutely dark. As soon as it began to dry again I could see the results clearly. I could not find a trace of tar anywhere. My object principally was to be delivered from the tar, and my effort was to stop condensation as soon as it could be done. That is what we are doing at Leavenworth to-day.

Mr. Watts—I would like to ask the average size of the particles of coal that Mr. Gimper is (and Mr. Lansden says he was) using so that we may be able to compare and determine whether the results tally. Mr. Gimper may have used either half or double the size of coal that Mr. Lansden employed.

Mr. Gimper—The coal that I used, as to the size of the pieces, was quite small.

Mr. McMillin—How big are the retorts?

Mr. Gimper—My experimental retorts are small (12 inches in diameter) and carbonize only 100 pounds at a charge.

Mr. Lansden—I fed the coal into the retorts by means of a screw carrier—the coal was powdered perfectly thin and fine—or as fine as I could powder it—and the gas was generated immediately as the material fell from the top to the bottom of the upright retort. The exhauster placed at the bottom was worked under a tenth of an inch vacuum. I also fed

in some steam through the coke fire that heated the retort. The question to be settled among ourselves is whether the internal portion of a lump of coal does not contain just as good gas as that from the crust; and whether the coal you are working, after three hours of roasting, is not just as good and rich in candle power as that from which the gas has been extracted in the first hours of the charge.

The President—I suppose if you were to use slack coal you would have the same benefit.

Mr. Lansden—No; it would run together then and coke. It will coke if allowed to remain at rest. It must be kept in motion all the time, and worked on the principle that I mentioned. It must not lie idle in the retort at all.

The President—I suppose some of those present remember that in Yonkers, N. Y., about six years ago, an inventor had a patent bench (three retorts on a side) for carrying out this plan of no mouthpiece condensation. There was only one mouthpiece, which was placed on the upper retort, to carry off the gas. The gas passed up from the bottom and came forward and out at the front. They got no great results from it, but did manage to make a great quantity of lampblack in every retort. The same thing will take place in a 20-foot in length through retort, for in case you charge one side of it and not the other in a few moments it will, from mouthpiece back, be covered with lampblack.

Mr. Thomas—Mr. Howard spoke about the Elmer process for using up the tar, but did not say anything about another New Yorker who also attempted to accomplish that object. The latter devised what might be called a double-decked retort—one retort being placed over another—and the thing was brought to such a stage of perfection that it at last became dangerous for the workmen to operate them, the supposition being that the men would be drawn in and gassed if they came too near the double-decker's front. I do not know whether they made 8 feet to the pound or not, but I do know that they had neither tar nor coke, and that it was dangerous, as I have said, for a man to get in front of the bench. After they had been operating for three or four months the mains, rather suddenly it seemed, began to leak, whereupon it was urged that the mains were very faulty. When asked why the mains did not leak when they were first tried the experimenters thought they had better take a few notes in regard to the situation. They claimed to be making from 7 to 8 cubic feet of gas out of every pound of coal put into the retorts, but the consumers' meter returns showed that there was a loss, as between production and consumption, of over 50 per cent. I was called in consultation by them, and my advice to them was to drop the double-decker, and that if they did so the mains would likely tighten up again. The counsel was followed out, and since then they have had coke and tar—and gas.

Mr. McMillin—I hope the members of the Association will not blame the tar entirely for the poor yield that most of them get. Mr. Lansden's statement gave us 12 feet to the pound. That is certainly 7 feet above the average, or 14,000 feet extra to the ton. That 14,000 feet would weigh between 500 and 600 pounds; but as the tar would only weigh something like 25 pounds, it cannot be held responsible for all of it. I think most of it came from the coke, if it did not come from the jet of steam which he introduced at the bottom—which is altogether probable. He was making water gas then, and did not know it. I am of the opinion that we do not get near the amount of gas from a ton of coal that we ought to get. I think that before five years have passed there will be as many gas men making 5½ feet to the pound as there are now who make but 5 feet. I think that Mr. Egner is on the right road. If he makes a mistake he will go back and start over again, and will probably blaze out the way for the rest of us to follow. This gain in gas does not, of course, come from the tar, for the tar in a ton of coal is too small to make all this gas; and I would not convert my tar into gas if I could. I can buy coal cheaper than I can buy coal tar. There are men who are getting more for their coal tar than the coal costs me; and, therefore, I do not want to make my coal tar into gas. If I can buy coal at \$2 per ton and sell my tar for \$2 per barrel, I will continue to make some tar. However, the extra yield, I take it, comes not from the tar, but from being able to volatilize more of the coal. I think that with proper facilities (I do not pretend to suggest what those proper facilities are) we will be able to volatilize about one-half of the coke left in the retort. There is hydrogen enough in the coal to make heavy and light carburetted hydrogen. We do not take that away: we decompose it. I think the sulphur color that we find on the coke in an extra hot retort is due to the graphite thrown down by decomposition from matter which, first becoming gasified, is afterward solidified from coming in contact with hot carbon. In my opinion Messrs. Gimper and Lansden are right in their statements. We do not want it to come in contact with that if we can avoid it; and I think it is possible to avoid it. I tried to demonstrate that sometime last

winter, in a letter to the AMERICAN GAS LIGHT JOURNAL,* by showing that it was possible to make a better gas when securing 5½ feet to the pound than when making 5.10. I believe that such a thing is possible, and that in doing it you might not get as much naphthaline as you do when making 5.10 or 5.25. I have, for some days at a time, run our heats up to where we got 5.45, and occasionally 5.50, and absolutely increased the candle power—I will not tell you how much, although I am almost tempted to do so after hearing these men tell their stories. But it is a fact that a decomposition may occur there that will form heavier hydrocarbons, which they do when you make naphthaline, and is just exactly what occurs probably by the decomposition of marsh gas. Now, there is a heavier hydrocarbon that forms, but you cannot keep it gaseous, and, therefore, the quality of your gas is reduced instead of being benefited—although the quantity is increased—because you have more hydrogen in combination with carbon. If you break that up it is possible to double your volume. If you form the right kind of hydrocarbons, then it is possible to keep them gaseous. Just what temperature will do that I will not undertake to say; but I say that there is a point where you can make 5½ feet of gas out of a pound of coal in ordinary clay retorts, and make it of an illuminating value in excess of 18 candles.

Mr. Lansden—I do not want it understood that I got this extra yield from coal tar. There is where I got my candle power from.

Mr. Howard—With the assistance of the water.

Mr. Lansden—I got 12 feet without the water gas.

The President—Did you ever try to distill coal tar by itself to produce gas, and then determine what candle power you got from it.

Mr. Lansden—No.

The President—Then try it sometime, and see what candle power you get from it.

Mr. Lansden—We manage to leave a lot of heavy oils, benzoles, etc., in our coal tar, and these I think ought to be valuable for enriching purposes.

Mr. Boardman—Having an idea that there was some valuable enricher in the coal tar, and as all kinds of enriching material cost us a good deal in the South, I thought I would try an experiment with it; but instead of putting the heavy tar that came out of my hydraulic back into the retort, I thought I would take those lighter tars that came over and were occasionally deposited in some of the drips not far from the exhauster—I carry the gas through quite a length of main before it reaches the exhauster. I used that light tar in lieu of an enriching oil, but I could not find that I got anything out of it. I do not know that it increased the yield perceptibly, and it certainly did not increase the candle power enough to warrant me its carrying it on.

Mr. Lansden—The reason that you got no benefit from it was that you had no hydrogen to pick it up.

Mr. Boardman—The light oils in the tar being hydrocarbons themselves, I thought by breaking them up I would probably get some little illuminant from them.

Mr. Lansden—You must have hydrogen beyond what is needed in your gases in carbonization to hold these illuminants in suspension.

Mr. Boardman—I do not think that is necessary. I use crude oil, which is a hydrocarbon, in the same way, and the light tar, having very little more specific gravity, should act in a measure like the crude oil; but I found that it did not.

The President—Perhaps some of the gentlemen present remember the original Gwynne process, in which hydrogen gas was passed through the retorts to take up the tar. He secured a yield of six feet per pound of coal, and had no tar. I believe the process, at least as tried in Elizabeth, N. J., was not a great success.

Mr. Lansden—But that was an artificial combination entirely. It is the natural hydrogen combination that I spoke about.

The President—Brother Page, having been in the coal tar business, for a lifetime, can tell us how much gas we can get out of a gallon of tar, and is also an authority on the value of "light" and "dead" oils.

Mr. Page—If the question referred to the residual products to be obtained from the distillation of the tar I could answer it. So far as I have read in foreign and American journals I do not think that anything great has ever been accomplished in attempting to make gas from coal tar.

Mr. McMillin—How much benzole do you obtain from the tar per ton of coal carbonized?

Mr. Page—About one-quarter of a gallon. Where regenerative furnaces are used no benzole is obtained. The tar made at one of the Boston (Mass.) gas works is almost valueless, because of its lack of carbon. At many points where excessively high heats are carried on the tar distiller fails to find any of the light products—not even naphtha.

Mr. Gimper—We sell all our tar to one party, but we have two wells, one of which holds the tar from the hydraulic main, while the other holds that from the condenser and scrubber. From the latter—it is a large well—we had not taken any tar (since 1882 or 1883) until quite recently, and the party who purchased it said it was of much better quality than that which came from the other storage well. That corroborates what Mr. Page has said. I never intended to advance the idea that condensed tar could be profitably used in making gas. My idea simply was that the distillation might be continued under certain conditions of heat, etc.

The President—At what temperature do you think it ought to leave the retort, passing through the stand-pipe? Did it get up to about 700°?

Mr. Gimper—I hardly think so; but I do know that the heat increased at once.

The President—You will not have much condensation at less than 700°. Instead of condensation you have a drying up of the particles, which, clinging to the stand-pipes, cause the latter to become clogged. If you hold a piece of paper in front of the mouthpiece you can ordinarily burn it by means of the issuing gas. There cannot be much condensation there under those circumstances.

Mr. Gimper—In the retort I mentioned as having a flat mouthpiece we carried a high heat. I do not believe that this moisture is condensed at once in the mouthpiece of the stand-pipe, even at a high heat.

The President—I would like to find moisture on my mouthpieces when I open them. I would be satisfied then that I would have no trouble.

Mr. McMillin—The temperature in the stand-pipe is, of course, too high for the watery vapor to condense unless a current of cold air is going in there. The temperature of the gases cannot be extraordinarily high unless when working under a very considerable pressure. With but very little above the atmospheric pressure you would not get a very high temperature from the steam in there. It is surprising, when you come to figure on it, how much steam is generated from your coal, even from the finest of it. We sometimes use coal in Columbus that will generate nearly as many feet of steam as of gas. In the Columbus experimental works where we catch the water, tar and gas, and separate all of them, we often find that the water will weigh as much as the gas. We reduce the heats very rapidly, but I would not expect that watery vapor to condense before it reached the hydraulic main, not extensively at any rate. Possibly some condensation might take place if the stand-pipes were not very hot.

Mr. Pratt—Perhaps heat theories are correctly based, but there is so wide a diversity in the range of temperature between the time you charge your retorts and draw out your coke that we must look for a pronounced variation both in regard to quantity and illuminating power of the gases obtained. When the charge is first put into the retort the inside of that retort must necessarily be cooled somewhat, and the temperature be reduced; but it then gradually increases until the vessel and its contents are at a high heat once more. As has been said, when the outside of the coal mass gets too hot the vapors cannot pass through that crust without being destroyed. That would leave your hydrogen almost free, but necessarily you would have a poorer gas. I would like to see these papers go a little further. The company that I am employed by, and perhaps it is so with the most of you, do not care whether their coal yields 5, 5½ or 6 feet to the pound, but they do care for the practice which will return the largest dividend. Now, can you secure the latter by keeping your yield up to the maximum point? If you cannot you do not want it, but if you can you do want it. I have tried a great many times to get a big yield; but when I came to figure up at the end of the month as to how I got that yield, I would find out that I got it at the expense of my coke, or of my labor account, or something else; then did I drop back a trifle, or be satisfied with a lower yield, I managed to secure some compensating return which more than recouped the extra yield—for instance, the gas would have a better illuminating power.

On motion of Mr. McMillin, the thanks of the Association were voted to Mr. Gimper for his paper.

The President—I would like to call the attention of the Association to the fact that the great fault of most of our members, and particularly of the younger ones, is that they seem to think that a paper should cover several sheets of paper; but if they prepared a paper of ten or twelve lines in length it would answer just as well for the purpose of discussion as a longer one.

GAS FROM LIME STONE.

Mr. Egner—Instead of a paper I will relate an experiment that I once made and which may interest you all. It was an effort to make gas out of the stones that are used here for building, or such as the streets of St. Louis are paved with. I actually made gas out of building stone. I

* See JOURNAL, Jan. 3, 1887, p. 13.

have taken ordinary quarry stone, broken up in fine pieces, to the Laclede gas works and made gas therefrom. I led two pipes (1 inch in diameter, and 30 inches long) from a small furnace into the retort. One of the pipes contained the broken stone, the other pipe being filled with charcoal. They were connected at the back. I then rigged up an arrangement which, for convenience, I will say was a hydraulic main; I filled that with a quantity of poor oil—oil distilled from coal tar. Then I heated the whole thing up, and got from it an illuminating gas. The theory is about like this. Limestone contains a certain quantity (I obtained 1,600 feet from a ton of the stone) of carbonic acid gas, and the latter can be expelled by heat, and when my apparatus extracted the gas from the broken stone the gas was passed on through the charcoal—the latter being heated to redness—where it was, I suppose, converted into carbonic oxide, which, on being passed through the oil, took up illuminants from the oil sufficient to cause the “finished” gas to burn with a quite bright flame. That experiment, however, is not likely to prove very profitable. I also made gas out of limestone by putting it in a vat of water diluted with sulphuric acid, and obtained carbonic acid gas after the manner of the mineral water manufacturers. Then I converted the gas into carbonic oxide by passing it through retorts filled with charcoal, and then carburetted it by passing it through naphtha, and also through tar oil. It had a very fair illuminating power.

Mr. McMillin—It does me good to be able to beat Egner in something. He said he only got 1,600 cu. ft. to the ton of stone, whereas I have made nearly 15,000 cu. ft. from a ton of the limestone material!

Mr. Egner—Did I say 1,600? I meant 16,000.

Mr. McMillin—There are no “second chances” allowed here. For convenience, let us place the weight of the ton at 2,000 lbs., and if we had a pure limestone it would contain 44 per cent. (880 lbs.) of carbonic acid. As $8\frac{1}{2}$ cu. ft. of carbonic acid gas equal 1 lb., it follows that the ton contains about 7,500 cu. ft. of the gas. For every foot of carbonic acid gas passed through incandescent coke you would obtain 2 cu. ft. of carbonic oxide, and by the time you had enriched the product you would easily have secured a total of 15,000 cu. ft. I supplied that sort of gas to a certain town, on two consecutive nights, some 15 or 20 years ago, and supposed I had found a bonanza. I did not know at that time how dangerous carbonic oxide was, and I had not been taught as much about water gas then as I have since learned. It could not be made very rapidly, because you cannot coke stone quite as fast as you can Pittsburgh coal. The experiment was made in a way very similar to the one described by Mr. Egner. In a bench of threes, carbonic acid was taken out in the first retort and passed into a 2-inch pipe (run into the back end of the second retort) filled with coke. Going forward it passed through the coke, was decomposed, and then passed through the third retort, where the enriching oils were placed. I got nearly 15,000 cu. ft. to the ton of stone. Of course we could make the gas as rich or poor as we desired, by using much or little of the enriching material. You can make a good gas in that way. Of course it is heavy, and you would require good sized mains, in order to crowd enough through. Originally I put up an experimental works in which the retorts were 4 feet long and 8 inches in diameter, and carried on the experiment with them until I thought I had solved the problem in a satisfactory manner. Then I branched out on a larger scale. I invited a friend to inspect the operation of the small works, which had been idle for a few hours prior to his visit—the purifying apparatus, washers, scrubbers, and everything of that kind being contained in one vessel. After starting the thing in operation and running it about long enough, as I supposed, to work off all the air, I opened the top and touched a match to it, whereupon some of the things went to the roof, and some of them did not. That so frightened the workmen that I could not afterward get them to operate the process on a large scale. I was then engaged also in the iron manufacturing business, and, while studying up some problem involved in the production of pig iron, got hold of a work (then recently published) by a German author, in reading which I discovered that my limestone operation was far from being new. The author referred to had, it appeared, years before suggested the same principle for manufacturing carbonic oxide for metallurgical purposes. I have now a paper among my literary accumulations (I read it before a scientific society 14 years ago) on that subject, and I assure you it is a very interesting one.

Mr. Watts—I think that Messrs. McMillin and Egner are about even. Mr. Egner made about 1,000 cu. ft. more gas to the ton, but he neglected the very important matter of telling us how many pounds of coke he got to the ton of rock.

Mr. McMillin—That is a matter of calculation. You could very easily see, when you break up the carbonic oxide, how much coke that operation would take. Each foot of carbonic oxide would be a little more than one-third the weight of the carbon which would come from the

coke. My recollection is that it was about 300 or 350 lbs. The quantity of coke required to decompose the carbonic acid was small; but the quantity required to coke the limestone was very large.

The President—How about the residuals?

Mr. McMillin—The residuals were very poor.

Mr. Boardman—The use of limestone in making gas reminds me of quite a successful operation of that kind carried on now in New York city by the managers of the Equitable Company. Through listening to this discussion I am inspired to say that, while Messrs. Egner and McMillin got carbonic oxide by decomposing limestone, the Equitable folks manufacture their carbonic oxide under the ordinary water gas system; therefore the latter might obtain a wrinkle from the former, and save money. (Laughter.) I shall propose to them now to make their carbonic oxide as these gentlemen did. There is another waste that they allow to creep in—an item which can be utilized very nicely. The quicklime left after the gas is made could be utilized in their purifiers.

Mr. McMillin—You cannot lay claim to that inspiration, either. Both Egner and myself tried that.

Mr. Boardman—I do not want every man in this house to claim it. At any rate, I was the first one who said it.

Mr. Jenkins—I think Mr. McMillin forgot to mention another instance which goes to show that the making of gas from stone is nothing new. They have a stone in parts of Indiana and Ohio from which they get gas; and all they have to do is to drill a hole through the rock, when they get all the gas they want.

Mr. McMillin—I was about to add that on looking over this paper that I read some time ago I found a few foot notes (they were not read at the time) proving that the cost of the limestone was about \$1 per ton, and at the same date I could get about \$2.50 for the burned lime; therefore I might give the gas away and still make \$1.50 per ton by the operation.

ASSIGNING SUBJECTS FOR PAPERS.

Mr. King—At the last or Columbus meeting of our Convention I was bold enough to make a motion, but it did not receive especial favor from the members. Now, although I may not renew that motion at the present time, I will ask Brother McMillin to tell us about the workings of the rule under which members are assigned subjects whereon to prepare papers to be read at the meetings of the Ohio Association. I think the fact that there seems to be a scarcity of papers for this meeting should lead us to give it a little attention, especially when we recollect the number of papers read at the Ohio Association (which is only 3 or 4 years old) with the number presented here. I do not know that I exactly understand the working of the rule in the Ohio Association; therefore I would like to have Mr. McMillin explain how that Association proceeds in the premises.

Mr. McMillin—It was suggested at the Columbus meeting of the Western Association that we should adopt the rule of the Ohio Association with respect to getting papers. It was also suggested by the President* of the American Association in his annual address, and I was the chairman of the committee† that took his address under consideration. I think the minutes will show that in both instances I opposed the plan, and while I had good reasons for such opposition these have now lost their force. The first time I opposed it I expected to be elected President of the Ohio Association, and the second time I opposed it I was President of the Ohio Association. Now that that body has a membership of 100, and as they are not allowed to re-elect a man to office until it has gone around among all the members, it will be at least 100 years before I shall again be its President, and so I have no objection to your taking up anything that seems advantageous in its rules—but I did not want you to monopolize it until we got through with it. The plan is this. Our Executive Committee meets each year, some two or three months before the date of the annual sessions. In the meantime the Secretary has been writing to the members of the Association and securing suggestions from them as to what questions they would like to hear discussed. About three times out of five we are able to assign the very question a man suggests back to the suggester. Having been thinking about the topic he is probably better prepared to write upon the subject than anyone else. In that way we get a list of 25 or more subjects suggested. I think the last time we had a list of 50 subjects. Then we cull from them the number that we think we can dispose of, and we assign those papers to the parties whom we feel sure will write upon them. I think it is with other persons largely as it is with me—that the hardest thing about writing a paper is to get the subject and the title. If a subject is assigned almost any of us are willing to jot down something about it. After the Executive Committee have selected the subjects upon which the papers

* See JOURNAL, Nov. 2, 1886, p. 264.

† See JOURNAL, Dec. 16, 1886, p. 362.

shall be written, and given the titles, and assigned the subjects to different members, it almost invariably happens that the members write upon the subjects assigned. At the last meeting I think we had twelve papers, and there had been but fourteen subjects assigned. In the two previous annual meetings we had about the same record. We selected fourteen or fifteen subjects, and had twelve or thirteen papers. They have ample time to give the subjects consideration and to prepare the papers, and I think you will bear me out in saying that they are quite as much as you could expect from Ohio men. Now since it might be a little inconvenient for the Western Association to appoint an Executive Committee for the purpose in view—it is convenient for Ohio to cause the Executive Committee to do the work, because being all located in one State, the members can get together without any trouble, while in this Association your Board of Directors is larger, and as its representation is distributed among several States, it would be difficult for them to get together—I therefore suggest that there be a special committee (to consist of the President, the two Vice-Presidents and the Secretary) appointed who shall have authority to select and assign subjects to members, and call for the writing of papers thereon. [Motion seconded by Mr. Egner, and adopted.]

(To be continued.)

The Waterhouse System of Electric Lighting.

The Waterhouse system of arc lighting, which we herewith illustrate, differs from other systems of electric lighting in a number of important particulars. Not only is the method of regulation new, but the lamps have a form of magnet not heretofore employed. The dynamo is of the closed-circuit type, and has three brushes on the commutator. Two of the brushes are placed diametrically opposite each other, while the third is placed near the upper main current brush, and is employed for the purpose of regulation. It will be remembered that in several prominent systems the current is regulated by shifting the brushes, to increase or reduce the current taken from the commutator, and the shifting is done by a magnet controlling a mechanism. In this case the brushes do not change position, and we naturally look for a resistance coil that takes the

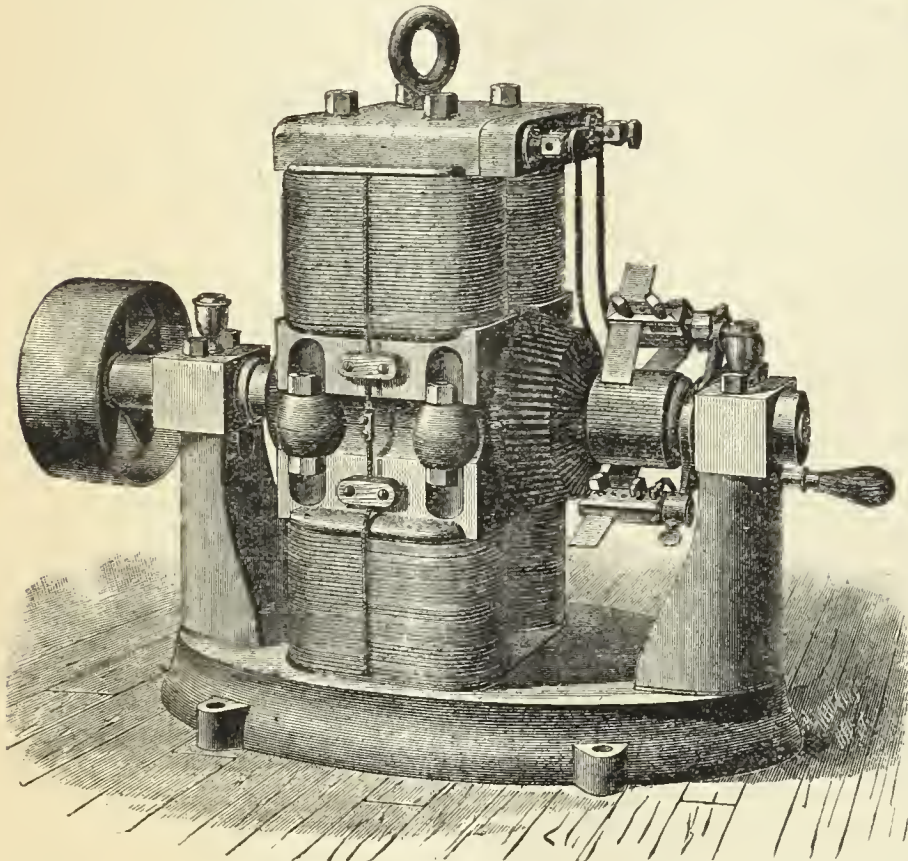

No. 3 Dynamo, Waterhouse System.

surplus current when the outside resistance is reduced—such as the cutting out of lights, etc. With such an arrangement the same power would be required whether the lights were burning or not; but we find that the Waterhouse regulator does save power as each light is cut out, and while they use the resistance equivalent to an arc lamp only in regulating, it is not for the purpose of compensating for the amount of resistance cut out on the line.

The following test made on an Otto gas engine proves the great efficiency of the Waterhouse regulator; for it will be noticed that as each light was cut out the amount of gas (power) consumed was reduced. The test was made on a 7-horse power gas engine; the machine being an 8-light dynamo. With eight arc lamps in actual duty the amount of gas consumed equaled 132 cu. ft. per hour; on cutting off one light the gas

consumption fell to 126 cu. ft. per hour; with six lights the meter registered the passage of 120 cu. ft.; with five, 114 cu. ft.; and four lights required 102 cu. ft. The machine was then short-circuited, without sparks or injury to it, owing to the control of the regulator, and the quantity of gas consumed was reduced to 42.6 cu. ft. per hour, the engine alone requiring 34.8 cu. ft.—making a difference of 7.8 cu. ft. to be charged to the friction of the machine.

The amount of power developed, including friction, was, for eight lights, 5.18-horse power; and for four lights, including friction, 3.58-horse power.

The figures show the economy of the system, both in regard to power required and efficiency in regulation.

Hartford, Conn., being looked upon as headquarters for mechanical skill, we should therefore expect that machinery manufactured there would be about the best of its kind. Looking, then, at the Waterhouse apparatus from a mechanical point of view, we find that the dynamos are well built and substantial. The armature shaft has long bearings. The machine rests on an iron pan, which serves two purposes—first, for collecting any oil drip that might saturate the floor space; second, to take up the slack in the belt, for the pan is provided with screw and nut for removing the dynamo far enough to accomplish that object.

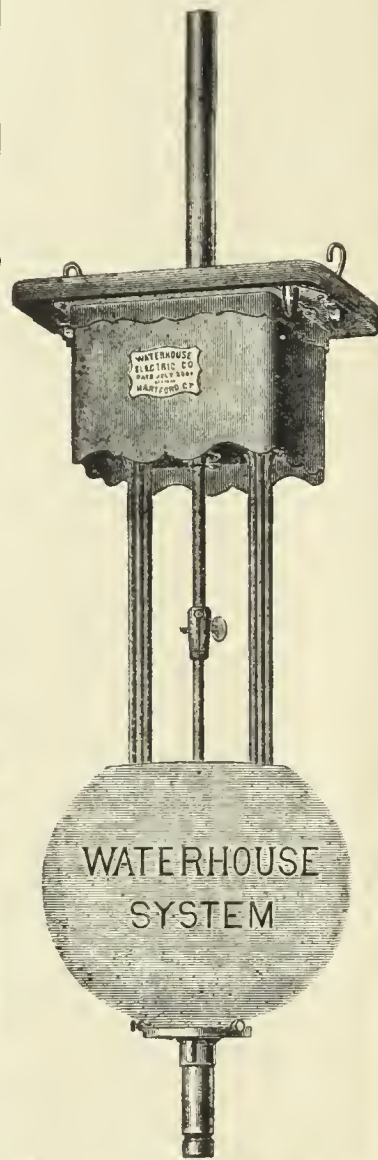

Single Carbon Arc Lamp.

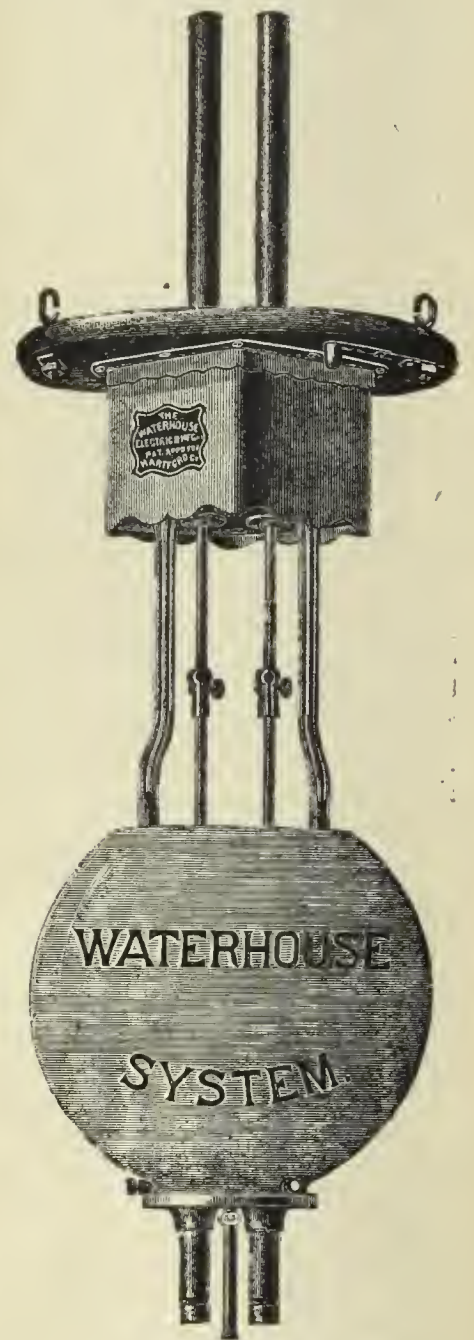

Double Carbon Arc Lamp.

The same attention to mechanical details is found in the construction of the arc lamps as has been given to the dynamos. The trimming can be done from the outside of the globe holder. The upper carbon rod has a pin for holding it up while the upper carbon is being placed in position. We illustrate the single and double carbon lamps, the magnet being of similar type in both examples. This form of magnet is new, and does not conflict with magnets of other arc lamps in patentable claims even on the magnetic principle involved. It is quadrangular in shape, and has main and shunt circuit coils, wound at right angles from each other, giving two variable poles on the magnet, which are utilized to attract an armature to which a simple lifting device is attached, thus lifting the upper carbon, which in so doing forms the arc. As the carbons burn away, causing separation and consequent high resistance in

the main circuit coils, the current takes the easier passage through the shunt circuit coils, producing a neutralizing effect to the magnetism in the variable poles of the magnet, and the armature that was at first attracted now lowers, by gravitation, and the lamp feeds.

The armature is so susceptible to the changes in the magnetism of the variable poles that the feeding is very gradual and fine, producing a light which is free from sudden flashing and commotion on that account.

The Waterhouse Company manufacture two kinds of single carbon lamps—a clutch-feed and a rack-feed respectively. They are also bringing out several new forms of arc lamps, but based on the same principle of construction. The double carbon lamp has same magnet as above described, and is adapted for all-night runs. It is made with rack-feed, and is constructed to change, from the burnt carbons to the new carbons, instantly, and at the proper time.

The Waterhouse incandescent system has just been completed. Under its operation the automatic regulation admits of the turning off or on of any number of lights without affecting those remaining in circuit; and the saving in power is reduced in same proportion or similar to that above stated when describing the arc system.

Both arc and incandescent lamps can be run from same circuit when so desired. The short-circuiting feature in the Waterhouse dynamo is of great value, as the burning of armatures, so common because of short-circuiting and switch board mistakes, is completely avoided.

The Cincinnati (Ohio) Gas Light Company vs. Chas. J. Steinau.

In our last issue we promised to make extended reference to the above-named case, and herewith publish the facts.

A short time ago Judge Maxwell enjoined Chas. J. Steinau from using any light in his store on Fourth street except gas, according to the terms of a contract for a term of ten years with the Gas Company.

Steinau had filed a demurrer to the petition, saying a Court of Equity could not interfere in a case of this sort, but that the remedy of the Gas Company was in a suit at law for damages for breach of the contract. Judge Maxwell overruled the demurrer. The Circuit Court has now sustained Judge Maxwell's decision, and the opinion here given holds the same doctrine as the first decision:

The demurrer of the defendant to the petition of the plaintiff admits the making of the contract between the plaintiff and the defendant whereby the Gas Company, in consideration of the engagement of Steinau, bound itself to supply to him at his storeroom, known as the "Palace," under the existing rules and regulations of said Company (except in cases of unavoidable accident), at a price therein agreed upon (and which was less than the rate then paid by the general public therefor), all the gas which might be required to properly illuminate the same for the period of ten years from March 16, 1886.

And that by the contract the defendant bound himself to receive from said Company all the gas necessary for the proper illumination of said premises during said term, in quantities not less than three-fourths of his then average consumption; and he further stipulated that he would not, during said period, introduce into or use on said premises oil lamps, electric lights, or other material or power for general illuminating purposes, or any other gas than that supplied by said Company; that the Company had duly kept and performed all of its stipulations in said contract, and is ready, able and willing to continue to do so, but that the defendant has broken his part of said contract by refusing to receive from the Company all the gas necessary for the proper illumination of said premises, and has introduced and is using on the same materials for general illuminating purposes, other than the gas supplied by the plaintiff, to wit, the Edison electric light, whereby the consumption of gas for illuminating purposes therein has been and will be largely reduced below the above stated monthly average, and much below the quantity he agreed to receive therein from said Company.

On this state of facts the question arises whether the petition states a good cause of action against the defendant, and entitles the Gas Company to the relief demanded, viz.: An injunction to restrain him from using the electric light on said premises, or from using any other material for illuminating purposes, other than the gas supplied by the plaintiff. The contention of the defendant is that although he admits all of these facts, yet that the plaintiff is not entitled to the relief sought because he has a plain adequate remedy at law for the breach of the contract, and that it would be contrary to the usages and practices of courts of equity to grant an injunction in such case.

Has the plaintiff, then, such a remedy at law? If not we understand it to be practically conceded by counsel for defendant that an action of this kind will lie.

It is the claim of the counsel for defendant that the plaintiff has three

such remedies at his command, either of which would be plain and adequate, viz. First, that he might bring his action at the end of each month of the term for the damages which had resulted from the breach of contract up to that time; or, second, that he might bring one action now to recover all the damages that he would suffer during the term, on the supposition that there had been a total breach of the contract; or, third, that he might wait until the expiration of the term and bring action to recover all the damages suffered by him before suit was brought.

It is apparent, we think, that this last mode would not afford an adequate remedy. The idea that the defendant can obtain redress for such a breach of this contract by waiting nine years to bring a suit to recover that which the defendant has stipulated to pay monthly is not to be entertained. Suppose the terms were one hundred years instead of ten, the same rule, of course, would apply, and if that was the only mode by which the plaintiff could obtain redress, it is manifest that it would practically be without any remedy.

We suppose it to be true that the plaintiff, under the state of fact existing in this case, would be at liberty to sue upon the contract, at the end of each month during the term, certainly to recover the contract price of the gas actually furnished during that month, and probably to recover also the damages sustained by the Company for a failure to take the amount of gas during that month which he had stipulated to receive. That is, that if there had been a total breach and abandonment of the contract by the defendant, but the Company still furnishes and the defendant still receives a part only of the gas stipulated for, that a right to bring successive actions for the damages so incurred would exist.

But if there be a total breach of the contract on the part of the defendant, as if he had entirely repudiated it, and refused to receive any gas whatever, and so advised the Company, then, as we understand the decision of the Supreme Court in the case of James vs. Board of Commissioners of Allen county to appear in 44 O. S., page —, and reported in Law Bulletin, volume 15, page 287, such excessive actions could not be maintained, but the remedy of the plaintiff would be in one action to recover all the damages he had or might sustain by a breach of the contract, and one recovery thereon would be a bar to a future action.

Conceding, then, the claim of defendant's counsel that under the facts of this case successive monthly action could be maintained, for a breach of the contract in not using the amount of gas stipulated to be used, is a Court of Equity debarred from enjoining the putting into said premises of electric light or other light in violation of the contract? It must be admitted that it is one of the plainest principles of equity jurisprudence that a Court may and ought in a proper case interfere by injunction to protect the rights of a suitor, when without it he could only assert them by bringing a multiplicity of suits. The only question as to this matter is as to the kinds of cases in which it may be done. It is stated in Pomeroy's Equity that the authority of a Court of Equity thus to interfere on this ground is undoubted in this class of cases, viz., "Where, from the nature of the wrong, and from the settled rules of the legal procedure, the same injured party, in order to obtain all the relief to which he is justly entitled is obliged to bring a number of actions against the same wrongdoer, all growing out of the one wrongful act, and involving similar questions of fact and law."—1st Pomeroy's Equity, Sec. 245.

It seems to us that this is precisely the case before us. The wrongful act complained of, and which is sought to be enjoined, is the introduction of the Edison light, in direct and admitted violation of the contract, and the necessary result of which, if continued and used during the term, would be to entitle the plaintiff to maintain successive actions for damages thus caused. If the plaintiff's only remedy is to bring these successive actions, they would be against the same wrongdoer and grown out of the one wrongful act, and must involve similar questions of law and fact; and, according to the clear doctrine of law, a Court of Equity may interfere to prevent such breach of the contract, and not require the plaintiff to resort to the multiplicity of actions to assert his rights.

But it is still further urged that there certainly is another mode by which the plaintiff may have an adequate remedy at law, and that is by an action now to recover the damages which may be found the Company will suffer during the whole term.

But the difficulty with this theory is that, in some respects at least, according to the allegations of the petition and the admission of defendant's counsel that the contract is still in force, and acted upon by both parties, gas is still furnished by the Company and received by the defendant. There is no claim whatever that it has been wholly abandoned by either party. Suppose, then, an action of the kind suggested were brought, what would be the measure of damages of the plaintiff?

The petition only alleges that since the introduction of the Edison light the defendant has used much less gas than he bound himself to use monthly, and will continue to do so. This the defendant admits by his

demurrer. But there is nothing to prevent the defendant from commencing at any time and continuing to use the full quantity contracted to be used, and what answer could be made on the trial by the plaintiff to proof offered by defendant that such was his intention? The mere fact that for several months past the consumption has fallen below the minimum agreed to be received, raises no legal presumption as to the amount that would probably be consumed during the residue of the term.

So far as concerns the damages for the part of the term before the trial, that would be easy to arrive at, but we know of no principle upon which there could be a satisfactory assessment of damages for the time yet to come, where there has not been a total abandonment of the contract, but where the parties are proceeding to carry it out, and where the amount, as in this case, of the gas consumed is simply less than the amount stipulated for, we are of the opinion that such action would not afford an adequate remedy in this case.

But aside from the proposition that a Court of Equity may properly enjoin where it is necessary to avoid a multiplicity of suits, we think that it is now settled by the authorities that where there is a clear and continuing breach of a negative covenant in a contract, and where an injunction against the breach of such covenant will do substantial justice between the parties, by obliging the defendant to carry out his contract or lose the benefit of the breach of it, and the remedy at law is not adequate, or the damages for such a breach are not susceptible of proper assessment by a jury, that a Court of Equity properly may and ought to restrain the defendant from such a breach of the contract, and that such is the case, although the Court might not be able to enforce a complete specific performance as against the other party.

As to this latter proposition there appears to have been a conflict in the authorities. But without any citations from the many cases to which attention has been called by counsel on either side, we simply state that in our opinion the doctrine as above stated is abundantly sustained, and must be considered as a settled rule of equity procedure. We therefore overrule the demurrer filed to the petition, and decline to suspend the injunction heretofore allowed, and, unless the defendant desires to file an answer, will decree in favor of the plaintiff, and make the injunction perpetual—that is, to enjoin the defendant from using upon his premises for illuminating purposes electric light or lights other than the gas furnished by plaintiff during the residue of the term, or so long as the plaintiff complies with its part of said contract.

Action of Oil on Metals.

Very little is known in regard to the action of well-known oils on metals with which they are brought in contact, and as the subject is one of importance, the results of following experiments, carried out with a view of ascertaining what fixed oils are best adapted for mixing with mineral oils for lubricating purposes, may be of practical value:

Brass is not affected by rape oil, least by seal oil, and most by olive oil.

Copper is not affected by mineral lubricating oil, least by sperm oil, and most by tallow oil.

Iron is least affected by seal oil, and most by tallow oil.

Lead is least affected by olive oil, and most by lard, sperm, and whale oil, which act nearly alike.

Tin is not affected by rape oil, least by olive oil, and most by cotton seed oil.

Zinc seems to be not acted on by mineral lubricating oil, least by lard oil, and most by sperm oil.

Conversely.—Cotton seed oil acts least on lead, and most on tin.

Lard oil acts least on zinc, and most on copper.

Mineral lubricating oil has no action on copper and zinc, acts least on brass, and most on lead.

Olive oil acts least on tin, and most on copper.

Rape oil has no action on brass and tin, acts least on iron, and most on copper.

Seal oil acts least on brass, and most on copper.

Sperm oil acts least on brass, and most on lead.

Tallow oil acts least on tin, and most on copper.

Whale oil has no action on tin, acts least on brass, and most on lead.

Mineral lubricating oil has, on the whole, the least action on the metals experimented with, and sperm oil the most.

For lubricating the journals of heavy machinery, either rape or sperm oil is the best to mix with mineral oil. Tallow oil should be used as little as possible.

ITEMS OF INTEREST FROM VARIOUS LOCALITIES.

CAPITAL INCREASE.—It is reported that the proprietors of the Buffalo (N. Y.) Gas Light Company have made application to increase the capital stock to \$1,000,000.

MR. FROST GOES TO BALTIMORE, MD.—Mr. W. H. Frost, who has been in the service of the Peoples Gas Light Company, of Brooklyn, N. Y., for some years, has accepted a position as Assistant Superintendent in the works of the Chesapeake Gas Company, of Baltimore. He is a careful, competent, and clever man.

ELECTRIC LIGHT FOR WORCESTER, MASS.—On May 31 the Worcester City Council voted to award the contract for electric street lighting to the Worcester Electric Company, at an agreed upon price of 55 cents per light per night. Last year the price was 60 cents.

PUBLIC LIGHTING AT TORONTO, CANADA.—In the estimates for carrying on the various public charges under control of the Fire and Gas Committee of Toronto, we note that the street lighting budget proper was placed at \$79,038, of which amount \$23,688 is set apart for electric lights. The estimate for "additional street lighting" is returned at \$6,150.

COMING DOWN AT PROVIDENCE, R. I.—Mr. Slater's Company has again seized the bull by the horns, for we learn that from and after 1st prox. the net rate for gas is to be placed at \$1.50 per thousand cubic feet. The present figure is \$1.70. Brother Slater, albeit one of the silent sort, manages to keep an active eye on the main chance, and never fails to improve an opportunity.

A GAS MACHINE COMPANY FOR THE GOLDEN STATE.—Articles incorporating the Union Gas Machine Manufacturing Company, of San Francisco, Cal., have been filed. The Directors are Messrs. J. Barrows, J. N. Withrow, C. D. McGown, C. L. Harkell, and J. Brickwedel. Capital stock, \$200,000, in 10,000 shares. Besides devoting attention to the manufacture of gas machines, these gentlemen also propose to construct gas works.

TAKING FORMAL POSSESSION.—Some time since we explained that the Mechanics Gas Company, originally owned by the Estey Organ Company, was to be purchased by the local gas suppliers of Brattleboro, Vt. The Brattleboro Gas Company took formal possession of their purchase on the 1st inst.

THERE'S NOTHING IN IT.—Mr. Samuel Bailey, Jr., acting on behalf of a syndicate, submitted, at a recent meeting of the Cincinnati (Ohio) Board of Public Affairs, an ordinance granting to himself, "his heirs, associates and assigns," a franchise to pipe to and through the city gas, natural or otherwise, for fuel and power purposes. The ordinance will receive consideration from the Committee on Streets—and also (particularly the "otherwise" portion) investigation at the instance of Gen. Hickenlooper. This means that "there's nothing in it for Bailey."

DR. CABOT GOES TO EUROPE.—Dr. John Cabot, who sailed from this port on the 4th inst., intends to visit the hospitals of Europe. His tray business will be continued during his absence by his partner, Mr. C. R. Whittier, at 306 to 310 Eleventh avenue. Mr. G. Shepard Page will represent Dr. Cabot in the West and South.

A GAS THIEF PUNISHED.—The Police returns of Brooklyn for June 1 show that John Roehringer, a liquor seller doing business at 311 Atlantic avenue, was found guilty of defrauding the Brooklyn Gas Light Company. By arranging a rubber tube to connect the pipes on both sides of the meter he managed to by-pass that faithful chronicler of the flow of gas, and (for a time) secured his light gratis. The fateful June Police report, however, mentions the further fact that Police Justice Walsh sentenced engineer Roehringer to pay a fine of \$200 for his ingenuity and iniquity, although did he so elect he might have gone to prison for 100 days. His fate prompts us to ask the Superintendent of the Flatbush (L. I.) Gas Company about what was done with Deacon Oberglock, who also toyed with a rubber tube.

A CORRECTION.—The following letter, from Mr. J. H. Decker, Supt. of the Hannibal (Mo.) Gas Company, explains itself: "In my contribution on the subject of 'The Selection of Cast Iron Pipe,'* I wrote, 'While we buy by the ton it is to the interest of the manufacturer to work in all the iron possible, and while one side of the pipe will be of the proper thickness the other side will be found from 10 to 20 per cent. too thick; [on the other hand, should we follow the suggestion made it

* See JOURNAL, May 16, p. 310.

will be to the interest of the manufacturer to save all the iron he can, and matters will simply be reversed—that is, while the one side is of the proper thickness the other will probably be from 10 to 20 per cent. too thin] and wherein have we bettered our condition? In the JOURNAL referred to that portion inclosed in brackets was omitted, which omission made a material change in the sense of the article." We are pleased to make the correction, and are further gratified to say to the fraternity that Brother Decker could not get to the St. Louis meeting—well, because it was a boy, and a bouncer at that.

ANNUAL ELECTION, KANSAS CITY, MO.—At the regular annual meeting of the Kansas City Gas Company a Board of Directors was chosen in the persons of Messrs. W. W. Gibbs, M. J. Payne, E. L. Martin, I. F. Wilson, and J. A. McDonald. Afterward organization resulted in the choice of M. J. Payne for President, H. E. Clark being named as Superintendent for the ensuing year.

ACCEPTED AND AUTHORIZED.—At a special meeting of the stockholders of the Consumers Gas Light Company (Toronto, Can.) the action of the Legislature in authorizing an increase of the Company's stock to \$2,000,000 was confirmed. They also passed a bye-law authorizing the Directors to issue \$500,000 new stock, in accordance with the provisions of the Act, in such amounts and at such times and places as they consider advisable. Work on the plant betterment is well under way.

FAVORABLE TO THE SYSTEM.—The Managers of the Waterhouse Electric and Manufacturing Company, of Hartford, Conn., print several strong testimonials favorable to their system, in the advertising pages of our current issue.

CHEAPER GAS FOR CEDAR RAPIDS, IOWA.—Mr. Wm. H. Christie, Supt. of the Cedar Rapids Gas Light Company, informs us that from and after first prox. the following schedule of gas rates will rule: Gross, \$2.50 per thousand; 10 per cent. off on monthly bills showing a consumption under 5,000 cubic feet; 15 per cent. on monthly consumption over 5,000 and under 10,000 cubic feet; 20 per cent. on monthly consumption exceeding 10,000. Those consumers who use gas in cooking stoves, between the dates of May 1st and Nov. 1st, and take up not less than 1,000 cubic feet each month, are entitled to receive the highest discount. The gross rate is to prevail in all cases where bills are not settled within ten days from date of presentation. The rate at present in vogue calls for a gross charge of \$3, with 50 cents off for prompt payment. Mr. A. T. Averill still remains at the head of the Cedar Rapids Company's affairs, and well he knows how to manage them.

PROPOSALS FOR GAS LAMPS AND PILLARS.—Mr. F. W. King, Gen. Supt. of Lamps, etc., for the city of Baltimore, Md., announces that sealed proposals will be received at his office (City Hall building) until Monday, June, 20, at 12 M., to furnish new gas and gasoline lamps for the coming year, as per specifications and sample lamps, these to be seen at his office. Separate proposals to supply gas lamp pillars are also asked for. The proposals will be opened, in the Mayor's office, on the afternoon of the day mentioned.

CHARTERED IN GILPIN COUNTY, COL.—On June 3d articles incorporating the Gilpin Light and Heat Company were filed with the Secretary of State for Colorado. The organizers propose to manufacture and distribute gas and electricity in Gilpin county, and have capitalized their Company in \$50,000. This Company, in all likelihood, intends to erect a works at Central City, which is the capital seat of Gilpin county, the town being located in a peculiarly-shaped valley lying at the east base of the mountain chain known as the Snowy Range. It is 40 miles west by north from Denver, with which place it is connected by rail. The famous Gregory gold bearing lode crops out near the lower end of Central City.

THE AUTHORITIES IN A HUFF.—In our last we referred to the desire of the city authorities of Portland, Me., to secure representation in the Board of Directors of the Portland Gas Light Company, and also reported how that desire had been negatived at the annual meeting of the Company. While not fully conversant with the reasons that led to such adverse action, we are nevertheless inclined to the opinion that the city's demand was not unreasonable, in view of the knowledge that the city owns something over one-quarter of the capital stock of the Portland Company; but whether or not the authorities should have been successful, their failure cannot be urged as a plea in defense of the childlike move since taken by them in the proposition mooted to dispose of the city's gas shareholdings at auction to the highest bidder. It really appears incredible that sensible men will occasionally try to injure their

noses in order to "spite" some other equally important portion of their frames; but, since seeing is believing, we submit that the Portland City Council was in danger of attempting the strange operation of "spiting" itself, in support of which belief we herewith present the following letter from a Portland correspondent: "Two reports were presented by the special committee to whom was referred the advisability of selling the city's gas stock. The majority report, signed by Ald. Gattey (chairman), stated that the committee had considered the matter, and voted (5 to 2) that it is not advisable to sell the stock. The minority report (signed by Ald. Smith and Councilman Spring) recommended the passage of the following: 'Resolved, That we deem it expedient, and for the best interests of the city, to sell at public auction, to the highest responsible bidder, all the shares owned by the city of stock in the Portland Gas Light Company.' Both reports were laid upon the table without discussion." We would remind the Portland authorities that temperance in action never proceeds from the intoxication of passion.

ANNUAL ELECTION, GEORGETOWN, D. C.—We understand that, on June 4, Messrs. Scymour, Marbury, Smoot, Knowles, Copley, Brown and Orme were elected a Board of Directors for the Georgetown (D. C.) Gas Light Company.

THE FINDLAY (OHIO) NATURAL GAS CELEBRATION.—The Findlay natural gas celebration, held on June 8, 9 and 10, was probably the most unique gathering (that is, in respect of the inciting cause) ever witnessed in any quarter of the universe. As the daily papers have devoted much space to the publication of the details of the affair, we need not here enlarge upon the matter, although we might say that the success of the undertaking was thorough and complete. It goes without saying that the Findlay gas men were quite equal to the occasion; in fact they bore the brunt of the burden, and deserve the lion's share of the applause.

ROCHESTER (N. Y.) TO BE LIGHTED BY ELECTRICITY.—The Lamp Committee of the Rochester City Council having agreed upon a scheme whereby the entire street lighting of the city was to be turned over to the electricians for the next 5 years, a special meeting of the Council was called to indorse the project, and the same was agreed to. Under the contract the Brush Electric Light Company is to furnish 489 lights, at the following rates: First two years, 30 cents each per night; next two years, 28 cents; fifth year, 27 cents. Lights to be of 2,000-candle power. Rochester Electric Light Company, 100 (or more) arcs, at the uniform rate of 28 cents per night in the life of the contract. Edison Electric Illuminating Company (incandescent lights, of 20-candle power, to replace present kerosene lamps) 700 (or more) lights at the following figures—each per night: 1st year, 4 cents; 2d year, 4½ cents; 3d year, 4¾ cents; 4th year, 5¼ cents; 5th year, 6 cents. Under this scheme, excluding the "or more" possibilities of the contracts, Rochester will have to pay the following sums for street lighting: 1887-8, \$82,708; '88-9, \$83,986.50; '89-90, \$80,486.15; '90-1, \$83,041.15; '91-2, \$81,110.35. There are great possibilities in the Edison end of that contract, and it will be interesting to note how the 20-candle-power premise of the specification will be adhered to.

BROTHER TRUMBORE SAYS GOOD-BYE.—Mr. Samuel Trumbore, who has been in harness for almost a third of a century, has determined to retire from active business life, and herewith says something about how the stated period was occupied: "I have this day (May 26) resigned my position as Superintendent to the Warren County (Phillipsburg, N. J.) Gas Light Company, with the intention of quitting the gas business for good. Having been connected with the said business since 1856—just 31 years—and in the employ of the Warren County Company from the time of its inception, I thought it might interest some of the readers of your JOURNAL were I to relate some of the changes and improvements that have taken place in Phillipsburgh (it is close to Easton, Pa.) in 31 years. In 1856 the Easton Gas Company, in whose employ I served, was sending out during the winter season about 20,000 cu. ft. nightly, and the loss in unaccounted-for gas, through defective street mains, was as high as 28 per cent. Iron retorts were used, and these would last about six months. The owners were getting \$4 per thousand for the gas supplied, and earned a dividend of something like 4 per cent. per annum. In 1869 they introduced clay retorts, which were not much of a success in the first year; but after reducing the dip in hydraulic main to a minimum, and somewhat later on removing the seal, better results were obtained. To-day the Easton folks are sending out about 130,000 cu. ft. per day, and are selling gas at \$1.90. In 1876 I left the Easton Company and came to Phillipsburg, which latter place was being supplied with gas from the Easton Company's mains. Thinking that Phillipsburg could support an independent Company, I broached the subject to the

local capitalists, helped to place the stock in the new enterprise, organized the Company, and put up the works. We commenced with 20 consumers and sold gas at \$2.25 net. To-day we have 220 consumers, and they are being supplied with gas at \$1.90 per 1,000. The yearly output of the Company is something like 4 millions cu. ft.; a 6 per cent. annual dividend is being paid, which rate has permitted of the accumulation of a small surplus applicable to extensions, and also a sinking fund. I can assure you, however, that the accomplishment of all this was no easy task, for it required much hard labor, both by day and night. I have now made up my mind to let someone else try his hand; so let me bid you good-bye as a gas man. Respectfully yours, SAML. TRUMBORE."

Only those who have had similar experience can appreciate completely the hard drudgery involved in building up a business on the lines followed by Mr. Trumbore, but patient toil sometimes brings with it, after years of doubt and hope, that reward which can only be enjoyed to the full by those who, having known weariness, rest easily in the possession of honest comfort wrung fairly from the encounter with fortune's buffetings.

A PATENT ISSUED TO GEO. H. GREGORY.—Considerable misunderstanding has existed in regard to the claim of Mr. Geo. H. Gregory, of Brooklyn, N. Y., who contended that he was the original designer of what is known as the "Arm Burner." Mr. Gregory appears at the present time to have much the best of the argument, for we note that, on May 31, a patent (No. 363,892) was issued to him exclusively, the leading features of which are as follows: "A gas burner adapted for use with a horizontal extending arm of a gas fixture, to be detachably secured thereto, comprising a pipe having an upward extending portion and a portion extending in a horizontal direction therefrom, a pipe extending downwardly from the last mentioned portion, an upwardly extending burner tip attached to the last-named pipe, a shade surrounding the downwardly extending pipe, and a support for the same."

TRIED BY FIRE.—Some time ago we noted that Mrs. S. S. Frackelton, of Milwaukee, Wis., had patented a portable gas kiln, for firing decorated china, which might be readily and profitably used by amateur workers in that line. Now, as some of the amateurs may possibly require a hint or two to cause their operations in decorative attempts to take on the desired effect, we call their attention to the fact that Mrs. F. is also the author of a volume, entitled "Tried by Fire," which describes in an elaborate manner the art of china painting. Those who wish to secure copies of that treatise can be supplied by an order sent to us. The work is profusely illustrated.

FACTS FOR THE LAWYERS.—An esteemed correspondent living in the Buckeye State, in commenting on the case of the Cincinnati Gas Light Company vs. Steinau (for a report of the decision reached see page 381, current issue), submits the following: "At the Dayton meeting of the Ohio Association some of the gentlemen who spoke against special prices claimed that it was not lawful to make such prices. If that is the case, how can this party at Cincinnati be compelled 'by law' to 'live up to his contract,' which, I understand, was based upon a special price.—SPECIAL." Perhaps Judge Jones, of Delaware, Ohio, might be induced to say a word or two on this subject. We rather think that the Judge had equity on his side in his Dayton remarks, but equity is not altogether the only constituent of the marrow in the particular bone under dissection.

THE GENERAL TAKES A HAND-IN.—Messrs. A. Hickenlooper, B. Allison, A. D. Bullock, J. H. Bates, T. D. Lincoln, and G. Wilshire have incorporated the Cincinnati (Ohio) Electric Illuminating Company, capitalized in \$500,000. The Company proposes to "generate, supply and sell electricity, and to furnish, supply and maintain arc and incandescent electric light, and to furnish, supply and maintain electrical motors for power purposes."

TO REORGANIZE.—A meeting of the stockholders of the Gate City (Atlanta, Ga.) Gas Light Company is to be held in Atlanta at 10 A.M., July 9, for the following objects: "To organize the Company; to adopt bye-laws; to elect officers; to do such other acts as the welfare of the Company requires."

WESTERN WAIFS, by "DIAPHRAGM."—For the following batch of newsy items we have to thank our wideawake correspondent; "Diaphragm." He writes: In a recent circular to its consumers the Rockford (Ills.) Gas Company announces that over 400 gas stoves are in use in that city—a showing to which the local gas men justly point with pride. A contract for the erection this season of a bench of sixes has been given out. Mr. Ed. G. Pratt, late Superintendent of the North

Attleboro' (Mass.) Gas Light Company, has arrived in Des Moines, Iowa, to relieve Mr. W. A. Agard, who for a number of years had controlled the destinies of the Capital City Company. Mr. Agard has formulated no precise plans for the future, but will take a much needed rest during the summer. He is well known and highly esteemed by his fellow gas managers throughout the West, and their good wishes will follow him. To Mr. Pratt the hand of good fellowship is extended, and it is to be hoped that the West, and Des Moines especially, will prove to be all he could desire. His family join him next month. Supt. Kellogg, of the Sioux City (Ia.) works has recently contracted for a bench of fives, and a new 5-foot station meter. He is kept very busy in keeping pace with the growth of his thriving city, the past year's increase in population having necessitated the placing of at least two miles of new mains. He reports, during the first five months of current year, an increase in each month in sendout over that of the previous month, which is an unusual state of affairs, and about which he feels supremely happy. Keep 'em stirring, Brother Kellogg. To keep pace with a well-deserved increase of business, the Danville (Ills.) Gas Company's plant has been enlarged from a 6-inch to a 10-inch one, with new condensers and purifiers. Manager Woodmansee has, therefore, about succeeded in putting his house in order, and awaits the coming of winter, happy in the knowledge that he can take care of his increased consumption and yet enjoy his night's rest. He is at present engaged in placing about 4,000 feet of 6 and 8-inch pipe to replace sections of 2-inch and 4-inch, the latter having ceased to be adequate to meet the demand made upon it. The Thomson-Houston people have obtained a franchise to operate an electric light plant at Nebraska City, Neb., but Supt. McMillin, undismayed, has given out a contract for the construction of two new settings of threes, and is preparing to put down about two miles of new mains. His city has the "boom" in its most pronounced state, and he reports that his business is steadily increasing, with a bright outlook for a continuance. 'Tis well. Joliet, Ills., over whose gas supply the whole-souled Moran presides, contemplates numerous changes and improvements this season. Two new benches of sixes will be contracted for. Supt. Mitchell, of St. Joe, Mo., is busily engaged in enlarging his retort house and making other improvements necessary to meet the new demands of the local gas consumers. Mr. J. H. Farish, late of the St. Louis Gas Light Company, has been appointed Secretary at St. Joe. Mr. F. is a genial, social gentleman, whom it is a pleasure to meet. His engagement by the St. Joe gas men was a happy selection, and will inure to their benefit. Supt. Baxter, of the Evansville (Ind.) Company, has just finished the erection of two benches of sixes. He has also built an experimental bench, with an iron retort, in which he expects to make some coal tests. He expects to experiment with natural gas, in case nature's product is found in or near by that city. We expect to report Brother Baxter's experimental doings when the hour of their consummation is at hand. The popular Ramsdell (who was greatly missed at the St. Louis meeting) has just returned from beyond the muddy Missouri. Accompanied by his wife he visited Omaha and Lincoln, in Nebraska, and Wichita, and other points in Kansas, returning filled to the brim with good words and glowing accounts of the booming far West. George, however, is well satisfied with Vincennes, and has buckled down to his summer's work with renewed vigor. Henderson (Ky.) will shortly have dollar-and-a-half gas. The plant is owned by the city. The Councilmen are thinking seriously of lighting the streets with electricity. Parties are boring for natural gas in the vicinity of Evansville, Vincennes and Terre Haute, the drills having reached a depth of 600, 1,200 and 1,600 feet, respectively. At none of the points named have indications favorable to a find been noted.

THE INCORPORATORS.—From the certificate of incorporation, filed with the Secretary of State, for Massachusetts, on May 28, we learn that those nominally interested in the Equitable (opposition) Company, now seeking for a franchise to operate in Springfield, are the following: President, H. M. Phillips; Treasurer, Emerson Wright; Directors, G. Wells, G. D. Robinson, E. Morgan, G. A. Dennison, and H. M. Phillips. The capital stock is placed at \$250,000. More work ahead for the Gas Commissioners. What does Springfield want with another gas company, anyway? The old Company has always dealt honestly with its patrons.

THE MILLS' LIME TRAY.—Mr. Geo. A. Mills is in receipt of many orders for his patent reversible lime trays. A line or two from a letter recently received from him is appended: "Orders are coming in thick and fast, for which very much is due to your very valuable paper."

WILL THEY TIRE OUT BROTHER CRESSLER?—Mr. A. D. Cressler, young and active though he be, keeps heaping up the work on himself in rather reckless fashion. We noted something about his rapidity of

movement in our last issue, and now we have to report that the workmen in the shops of the Kerr Murray Manuf'g Company are under orders to "get out" the following "stuff" forthwith: Two benches of sixes and eight benches of nines, with wrought iron diaphragm hydraulic mains and regenerative furnaces, constructed under the Arndt patents—Mr. Arndt is constructing engineer for the Chicago (Ills.) Gas Light and Coke Company—to the order of the Kansas City (Mo.) Gas Light and Coke Company; two benches of fives for the Jeffersonville (Ind.) works; two benches of sixes for Canton (O.) works; purifying boxes (8 ft. by 12 ft.) for Los Angeles, Cal., and sets of 6 ft. by 8 ft. for Bucyrus, O., and Morris, Ills.; new purifiers and other important general extension work for Watertown, Wis. We complete the list by mentioning a contract for a complete new 16-inch plant for the Birmingham (Ala.) Gas and Illuminating Company, to comprise rotary exhauster, hot scrubber, annular and multitubular condensers, tower washer, purifying boxes (16 ft. by 18 ft., with 16-inch center-valve), and hydraulic lifts for raising and lowering purifier covers. These are the items which caused us to make the introductory inquiry.

COMPLETION OF THE CHARLESTOWN (MASS.) GAS COMPANY'S ELECTRIC PLANT.—At the last meeting of the New England Association Mr. Neal explained that he was decidedly in favor of the policy of the joint supply of gas and electricity, and that he proposed to equip the Charlestown Gas Company with an electric plant which would be a credit to its owners and a surety to those who depended upon it for a supply of light. The combined efforts of Messrs. Hunnewell, Neal, Coyle and Gavin have redeemed this pledge, and now the light of the future is being sent out by the Charlestown gas men from a station that is a model of the excellent workmanship of the present. The station contains six 30-light dynamos, actuated by three 60-horse power engines, furnished with steam from boilers rated to a 300-horse power duty. The switchboard mechanism, devised by Mr. Gavin, electrician to the Company, is said to be exceedingly accurate and ingenious. The plant arrangement is such that an additional engine and two more dynamos can be added whenever the occasion for such extension arises.

HEMPSTEAD (L. I.) MATTERS.—The Hempstead Gas Light Company is putting in a 300-light incandescent plant on the Thomson-Houston system, which plant will be operated as a tender to the present gas supply. It is proposed to supply 20-candle lamps, and the town authorities have agreed to contract for 70 of the lights (to burn all night and every night) to do duty on the streets. They will pay \$25 per annum for each light. At present the authorities maintain 35 gas lamps, which latter will be discontinued when the electric plant is ready for duty—presumably about August 1. Perhaps the Hempstead gas men would find it profitable were they to overhaul their main system.

OUSTED.—The electric light suppliers have been lighting the public buildings of New Brunswick, N. J. for some time back, but a change has been effected in the practice, as the following hint, from one of our correspondents, discloses: "The electric light people, who had received about \$450 for the past year's lighting, offered to place meters in the buildings, and charge the county for the amount of light used; but when it became apparent that the Gas Company had charged at least 33 per cent. less for a *more satisfactory* light, there was but one thing to do, and the authorities have decided to ask the Gas Company to light the county buildings." Well!

GAS WAS TURNED ON AT VISALIA, CAL., for the first time in its history on June 1st.

OWING to the excessive overflow of the waters of Stony Creek, Johnstown, Pa., the local gas works were submerged, and the supply of gas cut off, on date of June 7th.

Correspondence

[The JOURNAL is not responsible for the opinions expressed by correspondents.]

Mr. Wells Gives Reasons for His Belief.

THE WELLS RUSTLESS IRON COMPANY, }
7 AND 9 CLIFF ST., CITY, June 6. 1887. }

To the Editor AMERICAN GAS LIGHT JOURNAL:

We notice on page 348 of your JOURNAL of the 2d inst., an article entitled "New Process for the Protection of Iron." In this article our process of forming an oxide on the surface of the metal is referred to as being an "expedient," and not presenting "a definite solution of the prob-

lem." We are somewhat surprised that you allowed such an article to appear on your columns.

The coating of iron with foreign substances, such as zinc, lead and copper, has been practiced for years, and has always been found unsatisfactory, because the iron and these metals have no affinity for one another, and consequently the iron repels or tends to push off the coatings.

We have not seen this new lead-coated iron, but presume it is no better than kalameined iron, which is really a lead-coated iron. Even if the coating should be a perfect one, it is no better than lead pipe, and will be gradually oxidized, as lead pipe is. It would not answer for boiler tubes or water pipes, for the heat would destroy the lead on the tubes, and people do not want to be poisoned with water containing a solution of lead.

Our pipe is being very largely used for conveying water, and is giving the very greatest satisfaction. There is an old saying that "The proof of the pudding is in the eating," and we all know that it is a very easy matter to get up a process to cover iron with a coating of some foreign material; but, heretofore, these processes have not stood the test of time.

Respectfully yours, W. T. Wells, President.

A Righteous Decision.

OFFICE KANSAS CITY GAS LT. AND COKE CO., }
KANSAS CITY, MO., June 8, 1887. }

To the Editor AMERICAN GAS LIGHT JOURNAL:

Probably you have not entirely forgotten the disastrous explosion which completely demolished the purifying house and boxes of the Kansas City Gas Light and Coke Company, on a stormy night in December, 1885. The concussion was so great that a number of buildings in the vicinity were more or less damaged. In all cases where the houses were undoubtedly injured by the explosion the Company repaired the damages, though admitting no liability. This liberality of the Gas Company was sought to be taken advantage of by the owner of a brick building located a furlong from the gas works, who made a claim for damages equal to the value of his house.

An inspection of the building was made under direction of the Gas Company, and it was found that the building had sustained no injury from the explosion, excepting a few broken panes of glass. This the Company was willing to repair; but that did not satisfy the rapacious owner, and the disagreement resulted in a suit against the Company for damages, in which negligence was, of course, alleged.

The suit came to trial in Judge Gill's division of the Circuit Court, in this city, recently. Numerous witnesses were examined in the trial of the cause, bringing out all the material facts. The plaintiff utterly failed to show negligence of the Gas Company, even with the aid of the chief of the Fire Department, whose evidence was relied upon by plaintiff to establish that theory. On the other hand, the Gas Company showed that the usual care in the management of gas works was in practice up to the moment of the explosion. There was no escaping gas, and no back pressure; the exhauster was working properly; the engineer was at his post of duty, and there was no indication of trouble. The concussion came and the walls of the building fell in and out, destroying the four purifying boxes and burying the engineer. That individual, when extricated from the debris, was found to have a broken leg, but had not been burned a particle—not even his clothing showed evidence of contact with fire.

The issue was well argued for plaintiff by counsel, and submitted to the Court, without argument, by defendant's counsel, on the evidence. The Court held that no negligence had been shown, on the contrary that unusual care had been proven by the defendant; that there was no explosion of gas at all; that if the explosion had been caused by the banking of escaping gas in the building until it came in contact with the gas jets in the engine room, as plaintiff had attempted to show, the result would have been the blowing of the walls altogether outward, and to have seriously, if not fatally, burned the engineer on duty. The fact that the walls of the building fell in as well as out, and that a human being was in the midst of the alleged gas explosion, and was not burned at all, not even his hair or whiskers having been scorched, is a complete refutation of the plaintiff's theory.

Judgment was given for the defendant. The finding of the Court sustained the theory of the Gas Company's officers that the explosion was the work of incendiaries.

Respectfully yours,
M. J. PAYNE, President.

CONSIDERABLE change has been effected in the method of carrying on the business enterprise heretofore so inseparably connected with the name of Thos. F. Rowland. For the new arrangement see advertisement of "The Continental Iron Works."



A. M. CALLENDER & CO.,
PROPRIETORS.

Editor—**JOS. R. THOMAS, C.E.**
Asst. Editor—**T. J. CUNNINGHAM.**
Manager—**C. E. SANDERSON.**

PUBLISHED ON THE 2ND AND 16TH OF EACH MONTH
At No. 42 Pine Street, New York.

This is a recognized official organ of—
LIGHT, HEAT, STEAM, WATER-SUPPLY,
VENTILATION, SANITARY IMPROVEMENT,
AND GENERAL SCIENCE.

TERMS

SUBSCRIPTION—Three Dollars per annum, in advance.

AGENTS

NEW YORK—AMERICAN NEWS CO. 39 and 41 Chambers St.
BOSTON—S. M. PETTINGILL & Co., 6 State Street.
PHILADELPHIA—PRATT & Co., Corner 9th and Arch Streets.
England—C. W. HASTINGS, 22 Buckingham St., London, W C
Germany—B. WESTERMANN & Co., of New York

THURSDAY, JUNE 16, 1887.

The Market for Gas Securities.

The city gas share market, at least so far as Consolidated shares are concerned, offers an excellent opportunity for purchasers at ruling rates. To-day (June 14) the opening price is returned at 81 $\frac{3}{4}$, and at that quotation there ought to be two points in it for buyers, the turn to be made before July 1. The Standard Company managers are going right along with construction work, but their future doings need not concern investment holders of Consolidated shares. We repeat that Mutual seems to present a safe front to investors, for the people now most heavily interested in the Company are well able and quite disposed to manage its affairs cleverly in case war is to be declared.

Brooklyn shares have taken an upward trip, and are likely to continue the journey for some steps ere their progress is checked. Comparing quotations for a fortnight back with those at present reported, it will be seen that the advance has been a pronounced one. We note the following sales at auction: 47 shares, Brooklyn, at 107 $\frac{3}{4}$; 14, Citizens, Brooklyn, at 60 $\frac{1}{2}$; 1, Metropolitan, at 87 $\frac{3}{4}$; also, 50 shares, California Gas and Construction Company, at \$6.

Montreal gas has sold up to 220 $\frac{3}{4}$. The Syracuse (N. Y.) Company's new issue of \$150,000 stock is to be offered at par, *pro rata*, to holders of record. Baltimore (Md.) shares are strong; and New Orleans (La.) gas is somewhat stronger. The Bay State (Boston) Company's managers are said to be anxious to secure control of the entire gas supply of Boston, and seem to have enlisted the services of the advertising department of the New York *Tribune* to secure that end. We have an idea, however,

that their anxiety will not be ended for some time to come.
Equitable gas (Baltimore, Md.), 1,089 shares, at auction, at 40-45.

Gas Stocks.

Quotations by Geo. W. Close, Broker and Dealer in Gas Stocks,
16 WALL ST., NEW YORK CITY.

JUNE 16.

All communications will receive particular attention.
The following quotations are based on the par value of \$100 per share.

	Capital.	Par.	Bid	Asked
Consolidated.....	\$35,430,000	100	80 $\frac{3}{4}$	81 $\frac{1}{4}$
Central.....	440,000	50	30	—
“ Scrip.....	220,000	—	47	57
Equitable.....	2,000,000	100	126	130
“ Bonds.....	1,000,000	—	113	115
Harlem, Bonds.....	170,000	—	—	—
Metropolitan, Bonds....	658,000	—	110	113
Mutual.....	3,500,000	100	101	103
“ Bonds.....	1,500,000	1000	101	—
Municipal, Bonds.....	750,000	—	—	—
Northern.....	125,000	50	30	—
“ Scrip.....	108,000	—	—	—
Yonkers.....	—	50	—	80
Richmond Co., S. I.	300,000	50	50	—
“ Bonds.....	12,000	—	—	—
Gas Co's of Brooklyn.				
Brooklyn.....	2,000,000	25	107	—
Citizens.....	1,200,000	20	59	61
“ S. F. Bonds....	320,000	1000	—	103
Fulton Municipal.....	3,000,000	100	141	142
“ Bonds....	300,000	—	—	106
Peoples.....	1,000,000	10	61	63
“ Bonds (5's).....	368,000	—	97	—
“ “ (6's).....	94,000	—	100	—
Metropolitan.....	1,000,000	100	87	—
Nassau.....	1,000,000	25	105	—
“ Cfts.....	700,000	1000	100	—
Williamsburgh.....	1,000,000	50	121	123
“ Bonds... ..	1,000,000	—	111	—
Out of Town Gas Companies.				
Boston (Mass.) Gas Co.	2,500,000	500	193	200
Buffalo Mutual, N. Y....	750,000	100	90	95
“ Bonds... ..	200,000	1000	95	100
Citizens, Newark.....	1,000,000	50	140	145
“ “ Bonds.	45,000	—	—	—
Chicago Gas Trust.....	—	100	63	64
Cincinnati G. & C. Co..	6,000,000	100	184	185
Consolidated, Balt.....	6,000,000	100	74 $\frac{3}{4}$	75
“ Bonds....	3,600,000	—	107	107 $\frac{1}{2}$
Chesapeake, Balt.....	1,500,000	100	100	—
“	1,000,000	—	100	102
Consumers Toronto....	1,000,000	50	192	—
Central, S. F., Cal.....	—	—	86	100
Capital, Sacramento, Cal.	—	—	56	58
Hartford, Conn.....	750,000	25	140	142
Jersey City.....	750,000	20	168	—
Laclede, St. Louis, Mo.	2,000,000	100	125	—
Louisville, Ky.....	2,570,000	50	130	132
Little Falls, N. Y.....	50,000	100	95	100
“ Bonds	25,000	—	100	103
Montreal, Canada.....	2,000,000	100	220	221
New Haven, Conn.....	—	25	193	197
Oakland, Cal.....	—	—	37	37 $\frac{1}{2}$
Peoples, Jersey City... ..	—	—	25	30
“ “ Bonds.. ..	—	—	—	—
Paterson, N. J.....	—	25	90	—
Rochester, N. Y.....	—	50	75	80
Syracuse, N. Y.....	350,000	25	—	—
St. Louis, Missouri.....	600,000	50	—	—
San Francisco Gas Co.				
San Francisco, Cal....	10,000,000	100	60	60 $\frac{1}{2}$
Memphis (Tenn.) Gas... ..	750,000	100	—	—
“ Bonds.	240,000	100	103	—
Washington, D. C.....	2,000,000	20	210	—
Wilmington, Del.....	—	50	200	208
Havana (Cuba) Gas Co.	3,000,000	100	18	20
“ Bonds.....	550,000	—	102	—

Advertisers Index.

	Page
GAS ENGINEERS.	
Jos. R. Thomas, New York City.....	396
Wm. Henry White, New York City.....	396
Wm. Mooney, New York City.....	396
William Gardner, Pittsburgh, Pa.....	396
GAS WORKS APPARATUS AND CONSTRUCTION.	
James R. Floyd, New York City.....	399
T. F. Rowland, Greenpoint, L. I.....	399
Deily & Fowler, Phila., Pa.....	399
Kerr Murray Mfg. Co., Fort Wayne, Ind.....	398
Stacey Mfg. Co., Cincinnati, Ohio.....	399
Bartlett, Hayward & Co., Baltimore, Md.....	389
Morris, Tasker & Co., Limited, Phila., Pa.....	398
Davis & Farnum Mfg. Co., Waltham, Mass.....	358
R. D. Wood & Co., Phila., Pa.....	398
Southwark Foundry and Machine Co., Philadelphia, Pa.....	398
Bouton Foundry Co., Chicago, Ills.....	387
PROCESSES.	
National Gas Light and Fuel Co., Chicago Ills.....	390
GAS AND WATER PIPES.	
Gloucester Iron Works, Phila., Pa.....	396
Meifert Foundry and Machine Co., Reading, Pa. (John Fox, Selling Agent, N. Y.).....	396
Cincinnati and Newport Iron and Pipe Co., Newport, Ky.....	396
Ohio Pipe Co., Columbus, Ohio.....	396
Pancoast & Rogers, New York City.....	396
M. J. Drummond, New York City.....	396
Wells Rustless Iron Co., New York City.....	387
GAS ENGINES.	
Schleicher, Schumm & Co., Phila., Pa.....	404
Clerk Gas Engine Co., Phila., Pa.....	391
RETORTS AND FIRE BRICK.	
J. H. Gautier & Co., Jersey City, N. J.....	394
B. Kreisler & Sons, New York City.....	394
Adam Weber, New York City.....	394
Laclede Fire Brick Works, St. Louis, Mo.....	394
Brooklyn Retort and Fire Brick Works, Brooklyn, N. Y.....	394
Borgner & O'Brien, Phila., Pa.....	391
James Gardner, Jr., Pittsburgh, Pa.....	394
Henry Maurer & Son, New York City.....	394
Chicago Retort and Fire Brick Works, Chicago, Ills.....	394
Baltimore Retort and Fire Brick Co., Baltimore.....	394
Oakhill Gas Retort and Fire Brick Co., St. Louis, Mo.....	394
Evens & Howard, St. Louis, Mo.....	395
Cincinnati Gas Retort and Fire Brick Works, Cincinnati, O.....	395
Emil Lenz, New York City.....	395
SCRUBBERS AND CONDENSERS.	
G. Shepard Page, New York City.....	397
REGENERATIVE FURNACES.	
Bartlett, Hayward & Co., Baltimore, Md.....	389
Fred. Bredel, New York City.....	395
GAS GOVERNORS.	
T. C. Hopper, Phila., Pa.....	392
CEMENTS.	
C. L. Gerould, Manchester, N. H.....	394
GAS ENRICHERS.	
Standard Oil Co., Cleveland, Ohio.....	400
GAS METERS.	
Harris, Griffin & Co., Phila., Pa.....	402
American Meter Co., New York and Philadelphia.....	403
The Goodwin Gas Stove and Meter Co., Philadelphia, Pa.....	403
Helme & McIlhenny, Phila., Pa.....	403
D. McDonald & Co., Albany, N. Y.....	403
Nathaniel Tufts, Boston, Mass.....	402
EXHAUSTERS.	
P. H. & F. M. Roots, Connersville, Ind.....	390
Smith & Sayre Manufacturing Co., New York City.....	399
Wilbraham Bros., Philadelphia, Pa.....	391
Connelly & Co., New York City.....	391
GAS COALS.	
Penn Gas Coal Co., Phila., Pa.....	401
Perkins & Co., New York City.....	400
Newburgh Orrel Coal Co., Baltimore Md.....	401
Despard Coal Co., Baltimore, Md.....	401
Chesapeake and Ohio R.R. Coal Agency, N. Y. City.....	401
Westmoreland Coal Company, Phila., Pa.....	401
Monongahela & Peters Creek Gas Coal Co., Pittsburgh, Pa.....	401
CANNEL COALS.	
Perkins & Co., New York City.....	400
J. & W. Wood, New York City.....	400
VALVES.	
Ludlow Valve Manufacturing Co., Troy, N. Y.....	392
John McLean, New York City.....	392
Chapman Valve Manufacturing Co., Boston, Mass.....	392

ENGINES AND BOILERS.	
Jurvis Engineering Co., Boston, Mass.....	391
PURIFYING MATERIAL.	
S. H. Douglas, Ann Arbor, Mich.....	395
GAS LAMPS.	
The Siemens-Lungren Co., Philadelphia, Pa.....	397
G. Shepard Page, New York City.....	364
Albo-Carbon Light Co., Newark, N. J.....	388
Standard Gas Lamp Co., Phila., Pa.....	395
PURIFIER SCREENS.	
John Cabot, New York City.....	395
Geo. A. Mills, Baltimore, Md.....	395
GAS STOVES.	
American Meter Co., New York and Philadelphia.....	393
The Goodwin Gas Stove and Meter Co., Phila. Pa.....	372
STREET LAMPS.	
J. G. Miner, Morrisania, New York City.....	395
Bartlett Street Lamp Mfg Co., New York City.....	392
BURNERS.	
G. Gefroerer, Phila., Pa.....	400
STEAM BLOWER FOR BURNING BREASE.	
H. E. Parson, New York City.....	396
GASHOLDER TANKS.	
W. C. Whyte, New York City.....	387
GAS FIXTURES.	
Mitchell, Vauce & Co., New York City.....	392
COKE CRUSHER.	
C. M. Keller, Columbus, Ind.....	401
GAS BAGS.	
Peerless Manuf'g Co., New York City.....	391
ELECTRICAL APPARATUS.	
Waterhouse Electric & Manufg Co., Hartford, Conn.....	388
BOOKS, ETC.	
English Journal of Gas Lighting.....	387
Gas as a Source of Light, Heat and Power.....	392
Goodwin's Directory of Gas Light Companies.....	400
King's Treatise.....	402
Scientific Books.....	402
Management of Small Gas Works.....	396
Newbigging's Gas Manager's Handbook.....	402
Gas vs. Electricity.....	399

FOR SALE,
Gas Works
IN A GROWING TOWN IN THE WEST.
The undersigned offers for sale a Coal Gas Works, in good condition, in a Western State. Population good. The reason for selling is that the owner cannot give the works his personal attention. Address 672-tf "O. E.," care this Journal.

FOR SALE,
Ten No. 2 Siemens Regenerative Gas Lamps,
With Factory Fixtures and Reflectors complete and in order. Only used three or four months. Will be sold cheap.
DANVILLE NAIL AND MFG. CO.,
Danville, Pa.

FOR SALE.
The St. Paul (Minn.) Gas Light Company desires to enlarge its works, and offers for sale the following apparatus, which is in perfect condition:
Six Benches of 6's.
Four Benches of 5's.
One Scrubber,
4 ft. 6 in. by 4 ft. 6 in. by 15 ft.
One 10-inch Exhauster.
Four 8 by 12 Purifiers,
10-inch connections.
Two 8-Horse Power Boilers.
One 4-Horse Power Engine.
One Coke Crusher.
THE ST. PAUL GAS LIGHT CO.,
670-4t E. I. FROST, Sec. & Treas.

FOR SALE,
Two Sinuous Friction Condensers,
Each 1 ft. 3 in. wide by 11 ft. 3 in. long, and 18 ft. high, of sufficient capacity for 225,000 cu. ft. per day. Apply to 665-12 PETER COFFEY, Supt. Gas Co., Peoria, Ill.

ENGLISH
"Journal of Gas Lighting."
Issued weekly. New volume commences Jan. 1, 1887. Price, \$7 per annum. Subscriptions taken by
CHARLES NETTLETON, Agent for U. S.
No. 115 BROADWAY, N. Y. CITY.

Bouton Foundry Co.,
FOUNDERS AND MACHINISTS,
CHICAGO, ILL.
Gas Works Apparatus,
PURIFIERS, CONDENSERS,
Bench Work,
SPECIALS, LAMP POSTS,
SCRUBBERS,
Iron Roofs and Floors.
Plans and Estimates furnished for new works or extensions of old works.

Engagement Desired.

The advertiser, an English Gas Engineer, age 25, seeks an engagement
As Gas Works Manager or Assistant Manager.
Thoroughly understands the manufacture and distribution of gas, and is a good draughtsman and chemist. Address 672-6t "H." care this Office.

Engagement Desired,

By a young man of several years' experience in the manufacture and distribution of coal gas, either
As Superintendent of a Small Works or Assistant in a Large Works,
Or with a Manufacturing Company or Contractors for the erection of gas works. Best of references. Address 672-2t "A." care this Office.

Water & Gas Pipe.
RUSTLESS Send for New Catalogue. **RUSTLESS**
The WELLS RUSTLESS IRON COMPANY,
Nos. 7 and 9 Cliff Street, New York City.

GASHOLDER TANK CONSTRUCTION, ETC.
Gas Companies and others about to erect Gasholders will find it profitable to consult W. C. WHYTE, who for over thirty years has made a specialty of
Holder Tank Excavation and Mason Work.
Fifty tanks now in operation show the sort of work done. Address
W. C. WHYTE, No. 15 Cortlandt St., N. Y. City.

To All Whom It May Concern!

The SIEMENS-LUNGREN COMPANY hereby warns the public against the use of various infringing Regenerative Gas Lamps which are offered for sale. This Company has heretofore delayed bringing suit to enjoin the manufacture or importation of such infringing lamps, solely because of the practical worthlessness of the infringing devices; and although, in each instance, they infringe some one or more of the various patents owned or controlled by this Company, they have fallen into disuse sooner than any suit could be brought to a hearing. As, however, the introduction of these infringing lamps has tended to discredit the practicability of our Company's system of regenerative gas lighting, we have instructed our Attorneys, Messrs. Geo. Harding, C. S. Whitman, and Silas W. Pettit, to give notice that legal proceedings will in future be taken against all such infringers.

THE SIEMENS-LUNGREN CO., 21st St. & Washington Av., Phila., Pa.

THE ALBO-CARBON LIGHT!

The Perfection of Gas Lighting.

Producing the Highest Illumination yet obtained from Gas, and
EFFECTING A SAVING IN ITS CONSUMPTION.

It has been most effective in

Replacing Electricity,

AFFORDING A

SOFT WHITE LIGHT
of EXTREME BRILLIANCY & POWER.

It has been most successful in

Supplanting Kerosene,

Giving Increased Light, Less Heat, and Perfect Safety
WITHOUT ADDITIONAL COST.

NOTICE.—Suits are pending in the United States Circuit Courts in Illinois and Pennsylvania against various parties for infringement of our Letters Patent No. 247,925, dated October 4, 1881, and No. 333,862, dated January 5, 1886. The first of these suits has come up for hearing, and an injunction has been granted therein. The second of said suits has not yet been reached for hearing. All persons are cautioned against manufacturing, selling, or using any apparatus or material which infringes our Patents. We intend to prosecute all parties infringing patents owned by us.

THE ALBO-CARBON LIGHT COMPANY, - - - NEWARK, N. J.,
Sole Manufacturers for the United States.

The Waterhouse System of Arc and Incandescent Lighting.

OFFICE HARLEM LIGHTING CO., }
242 E. 122d St., New York, Apr. 1, 1887. }

WATERHOUSE ELECTRIC & MFG. CO., Hartford,
Conn.—Gentlemen: It is with pleasure we write in commendation of your system of Electric Lighting. Before entering into the business the first question to settle in our minds was, "What shall we do to give ourselves (a new company) an equal footing or, if possible, an advantage over the old and established companies in such a field as New York city," which was apparently overrun with various systems in close competition with one another. There was but one answer to this question, to wit: "Get the system that will produce the best light at the least cost." We carefully looked into the best systems, aided by those who had had much experience in such matters, and finally adopted your system; and after several months' experience in operating the same we feel it our duty to say we are more than pleased. Our customers have no complaints, and our business is increasing beyond our expectations. We have run 116 of your arc lamps from our 76-horse power engine, with three belts on one pulley and two on the other, and with 80 pounds of steam. We are fully satisfied that we produce the best light in New York, and that we do it at a cost of from 30 per cent. to 40 per cent. less than any other company for coal and repairs. We have just increased our plant to 270 lamps, with power for 700 lamps, and expect to increase to 1,000 within another year. Our station will be second to none on the continent. We think your system of regulation deserves special mention; it works instantaneously, and keeps the lights perfectly steady. The machines run cool, and no burning out of

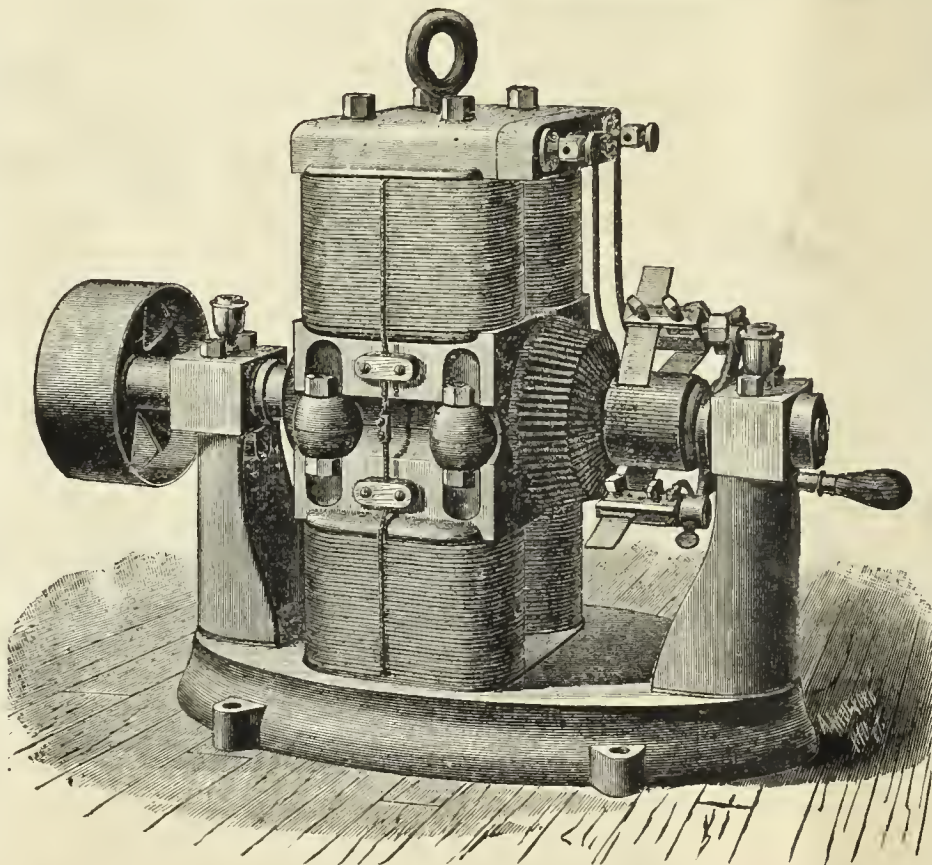

any part has occurred in either machine or lamps. The light is white and steady, producing the appearance of sunlight. We will gladly answer any inquiries in reference to your system from anyone who may wish to know its many advantages.

HARLEM LIGHTING CO.,
A. L. SOULARD, Prest.

When in Competition.

NEWARK SCHUYLER ELECTRIC LT. CO., }
NEWARK, N. J., Mar. 23, 1887. }

WATERHOUSE ELECTRIC & MFG. CO., Hartford,
Conn.—Gentlemen: The Waterhouse system has been in operation in our station for the past 2½ months, and we are pleased to say it has given both our company and our customers entire satisfaction. We doubt if the light produced is equaled in color or steadiness by any other system. We consider your three-quarter (¾) arc fully as strong as the so-called 2,000-candle power lights owned by other parties with whom we are competing, and we are daily substituting, in place of the said 2,000-candle power lamps, our three-quarter arcs with perfect satisfaction to the customers. We have thus placed 96 lamps during the past 60 days, and have orders for enough to tax our capacity, which, however, we expect to increase. Your regulator we consider deserves especial mention; it works so quick and perfect, immediately reducing the power consumed in proportion to the lights turned off. Your workmanship and material, so far as we can judge, are of the best, and we are pleased to say your claims and representations, when negotiating with us, have now been fully demonstrated.

Yours truly,
F. B. MANDEVILLE, V.-Prest. & Treas.

NOTE.—Since above date 100 more arc lights have been added to this plant.

FEATURES OF THE SYSTEM.—A White, Noiseless, Steady Arc Light; Instantaneous Automatic Regulation; Great Economy of Power.

MANUFACTURED BY

THE WATERHOUSE ELECTRIC & MFG. COMPANY,

Factory, Colt's West Armory.

HARTFORD, CONN.

BARTLETT, HAYWARD & CO.

Baltimore, Md.

Munich Regenerative Furnace, System Drs. Schilling & Bunte.

Greatest durability; minimum of attention; complete distillation in 3½ hours; 10 to 13 pounds of coke to hundred-weight of coal; no clinker; no carbonic oxide in regenerative flues.

TWO AND THREE-LIFT TELESCOPIC GASHOLDERS,

With Wrought Iron Tanks, constructed above ground, of any magnitude.

Condensers, Scrubbers, Purifiers, Bench Castings, Roofs, Boilers, Etc.

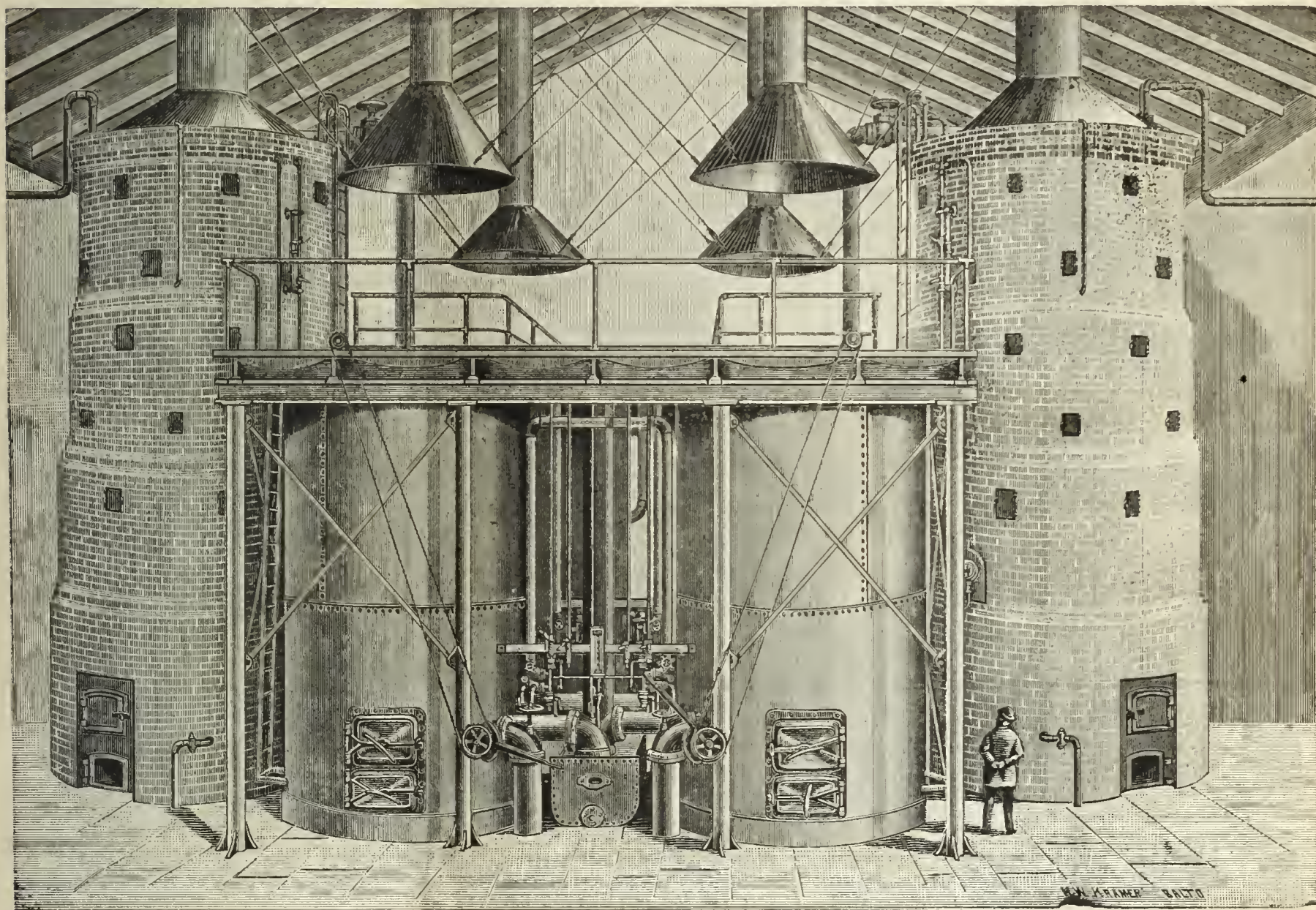

The Wilkinson Water Gas Process.

Introducing the Munich Regenerative Furnace for Coal Gas, we find on the part of many Gas Companies the desire to combine to a greater or less extent an efficient system of making high candle power Water Gas; and with a view of enabling this to be done WITHOUT EXCESSIVE CHARGES FOR PATENT RIGHTS, ETC., we have acquired, by purchase, the exclusive right to construct all the Water Gas Apparatus under the valuable "Wilkinson" Patents.

The results obtained by this Process are far better than those obtained by any other apparatus, especially where an illuminating gas of high candle power or a fuel gas of intense temperature is required.

The Process is uninterrupted, making gas of uniform quality and quantity. Its greatest advantages are maximum production with minimum material and labor, combined with great durability of apparatus.

The Process is in successful operation at the works of the N. Y. Mutual Gas Company, New York; Consolidated Gas Company, Baltimore, Md.; the Hudson County Gas Light Company, of Hoboken, N. J.; and at Rye, N. Y.

We shall be glad to give further detailed information upon application.

BARTLETT, HAYWARD & CO.

EXHAUSTERS.

EXHAUSTERS.

EXHAUSTERS.

THE ROOTS GAS EXHAUSTER.

CINCINNATI, OHIO, March 24, 1887.

P. H. & F. M. Roots, Connersville, Ind.: Gentlemen—I have the honor to say that after the continuous and uninterrupted use of your Exhausters for a period of fifteen years, it affords me pleasure to endorse them in the highest possible terms.

Very respectfully,

A. HICKENLOOPER, Prest. Cincinnati Gas Co.

CINCINNATI GAS LIGHT AND COKE CO., Cincinnati, Ohio, two No. 6 Gas Exhausters, with Engine, for their new works, which, with the two No. 6 Exhausters, without Engines, at their old works, and one No. 3, with Engine for pumping, for their station at Carthage, make five Exhausters in all for this Company.

CHICAGO, ILL., March 24, 1887.

Messrs. P. H. & F. M. Roots, Connersville, Ind.: Dear Sirs—We have two of your No. 6 Exhausters at our works, which have been running for several months, and are giving very good satisfaction. Yours truly,

THEO. FORSTALL, Prest.

THE CHICAGO GAS LIGHT AND COKE CO., Chicago, Ill., two No. 6 Gas Exhausters and Engine combined on same bed-plate.

St. LOUIS, Mo., March 21, 1887.

Messrs. P. H. & F. M. Roots, Connersville, Ind.: Dear Sirs—In 1872 one of your No. 5 Exhausters was placed in these works, and worked satisfactorily. March, 1885, it was replaced by one of your No. 6 Exhausters. The latter has been in almost constant use the past two years, has worked up to all my expectations, and is to-day in apparently as good condition as when first set up. It has not cost one cent for repairs in all that time. I have also had one of your No. 1 Exhausters, with Engine on same bed-

P. H. & F. M. ROOTS, Patentees and Manufacturers, **CONNERSVILLE, IND.**

S. S. TOWNSEND, Gen. Agt., 22 Cortlandt St., N. Y.

COOKE & CO., Selling Agts., 22 Cortlandt St., N. Y.

plate, fitted with your valves and Huntton Governor, placed in a small works under my control, and in its operation it seems as near perfection as I ever expect an Exhauster to become. Without in the least disparaging Exhausters of other makes, I may say that your Exhauster may be safely recommended as unsurpassed by any other, to those requiring such machines.

Yours respectfully,

FREDERIC EGNER, Eng. and Supt.

CLEVELAND, OHIO, March 22, 1887.

Messrs. P. H. & F. M. Roots, Connersville, Ind.: Gentlemen—Concerning the Exhauster furnished this Company by you last fall, I can say but little—indeed, much need not be said. It simply does its work perfectly, and in a way that inspires confidence that it will not shirk its duty when one's back is turned. If I wanted another 1,000,000 capacity I should try and duplicate our No. 4. Very respectfully,

EDWARD LINDSLEY, Eng. and Supt.

PEOPLES GAS LIGHT CO., Cleveland, Ohio, one No. 4 Exhauster and Engine combined on same bed-plate, Pipe Fittings, Gas and Bye-Pass Valves, Governor, etc.

INDIANAPOLIS, IND., March 21, 1887.

P. H. & F. M. Roots, Connersville, Ind.: Gentlemen—The No. 4 Exhauster and Engine which you erected for us last summer has done all you claimed for it, and has given us perfect satisfaction. Yours very truly,

JAS. SOMERVILLE, Eng. and Supt.

INDIANAPOLIS GAS LIGHT CO., Indianapolis, Ind., one No. 4 Gas Exhauster and Engine combined on same bed-plate, Pipe Fittings, Gas and Bye-Pass Valves, etc. This Exhauster has a capacity of 1,000,000 cu. ft.

DURING THE PAST YEAR, THE

NATIONAL GAS LIGHT AND FUEL CO.

218 LA SALLE ST., CHICAGO,

Have Erected Twelve Sets of Water Gas Generating Apparatus under the *Springer Cupola* System. They are as follows:

Newton Illuminating Company, Newton, Kansas.—Daily capacity, 120,000 cu. ft.

Wellington Light & Heat Co., Wellington, Kansas.—Daily capacity, 120,000 cu. ft.

Chippewa Falls, Gas Light Co., Chippewa Falls, Wis.—Daily capacity, 120,000 cu. ft.

Elkhart Gas Light & Coke Co., Elkhart, Indiana.—Daily capacity, 120,000 cu. ft.

Madison City Gas Light Company, Madison, Wis.—Daily capacity, 120,000 cu. ft.

South Bend Gas Light Co., South Bend, Indiana.—Daily capacity, 250,000 cu. ft.

Sheboygan National Gas Comp'y, Sheboygan, Wis.—Daily capacity, 120,000 cu. ft.

Salina Gas Light Company, Salina, Kansas.—Daily capacity, 120,000 cu. ft.

Rathbun Company, Deseronto, Province Ontario.—Daily capacity, 80,000 cu. ft.

Jefferson City Gas Light Co., Jefferson City, Mo.—Daily capacity, 120,000 cu. ft.

Mankato Gas Light Company, Mankato, Minnesota.—Daily capacity, 80,000 cu. ft.

Minneapolis Gas Lt. & Coke Co., Minneapolis, Minn.—Daily capacity, 1,000,000 cu. ft.

1886

1886

CONNELLY & CO., LTD.,

SOLE MANUFACTURERS OF THEIR PATENTED SPECIALTIES.

"IRON SPONGE." Saves money, saves labor, and is the most efficient purifying agent ever offered as a substitute for lime. Now used in every State in the Union, and purifying daily over twenty-five million cubic feet. Should be used in every gas works. Its own saving will pay for it many times over.

AUTOMATIC GOVERNOR. Has been on the market but two years, and in that time has been introduced more generally than any invention ever designed for use in gas works. Over one hundred of them now in use. Sensitive; reliable; perfectly automatic; reduces leakage; satisfies consumers, and gives great relief to the Manager. No gas works is complete without one of these machines.

STEAM JET EXHAUSTER. Designed particularly for small works. Combines Exhaust Tube, Steam Governor, Gas Compensator, and Bye-Pass Valves in the most compact form possible; occupies but little space; uses very little steam; operated by ordinary workmen; saves formation of carbon in retorts; increases yield 10 to 15 per cent. Specially adapted for mixing air with oil gas. No works too small to use them profitably.

Prices given on all our specialties delivered at any point in the United States. Correspondence solicited.

CONNELLY & CO., LTD., No. 177 Broadway, New York City.

WILBRAHAM GAS EXHAUSTER

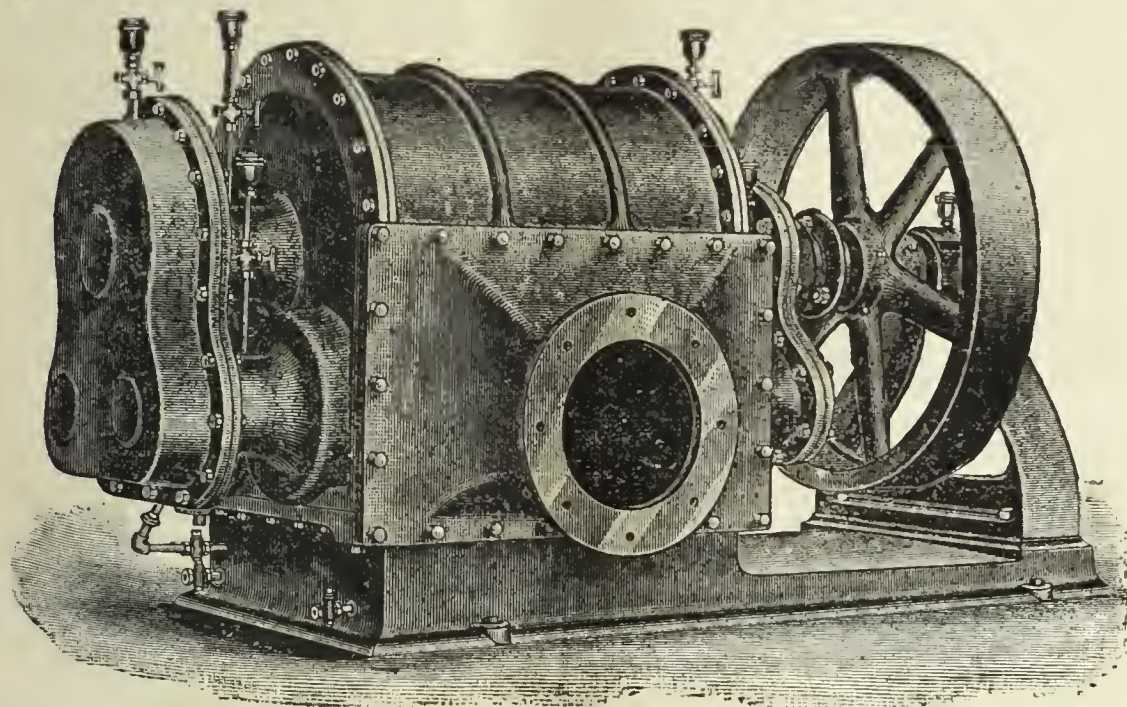

WILBRAHAM BROS.,
PHILADELPHIA, PA.

JARVIS ENGINEERING CO.,

61 Oliver St., Boston, Mass.

CONTRACTORS FOR ERECTING

COMPLETE STEAM OUTFITS FOR ELECTRIC LIGHTING STATIONS.

Steel Boilers set with Jarvis Pat. Boiler Setting,

To burn **COKE SCREENINGS** for Fuel.

ARMINGTON & SIMS CO. ENGINES,

Belting direct to Dynamos, without using Shafting.

SEND FOR CIRCULARS.

REFERENCES.—Charlestown Gas & Electric Light Co., Charlestown, Mass.; Schenectady Gas & Electric Light Co., Schenectady, N. Y.; Brookline Gas Co., Brookline, Mass.

Improved Patent
**GAS BAG OR
BLADDER VALVE.**

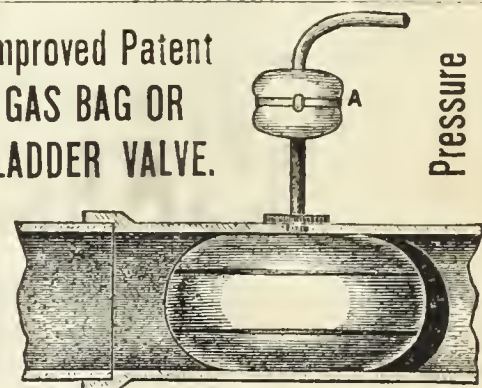

Pressure
Indicator.

MANUFACTURED BY
PEERLESS MFG. CO., 34 Murray St., N.Y.

THE CLERK GAS ENGINE CO.,

Main Office, 1012, 1014, 1016, 1018 Filbert St., Philadelphia, Pa.

WM. W. GOODWIN, Prest.

E. STEIN, Sec.

S. LEWIS JONES, Asst. Sec.

A. J. DOTY, Supt.

The utility and convenience of the Gas Engine being no longer an open question, it only remains now for intending purchasers to select the BEST. We claim for the CLERK GAS ENGINE that it is equal to any other manufactured as regards steadiness in running, simplicity, and ease of keeping in repair, and that it gives the greatest amount of power for the least money (both in first cost and expense of running) of any engine made. In support of this claim we refer to the test of the Gas Engines made under the direction of the American Institute of New York, in December, 1885, and heretofore published in these columns. These engines are especially adapted for continuous running under heavy loads, and we can refer to Engines which have run 22 hours a day for months at a time.

Made in Sizes of 5, 10, 15, 20, and 25 Horse Power. All Engines Guaranteed for One Year.



CHAPMAN VALVE MANUFACTURING CO.,

MANUFACTURERS OF

Valves and Gates for Gas, Ammonia, Water, Etc.

Also, Gate Fire Hydrants With and Without Independent Nozzle Valve. All Work Guaranteed.

WORKS & GEN'L OFFICE:
Indian Orchard, Mass.

TREASURER'S OFFICE:
72 Kilby & 112 Milk Sts, Boston, Mass.

LUDLOW VALVE MFG. CO.

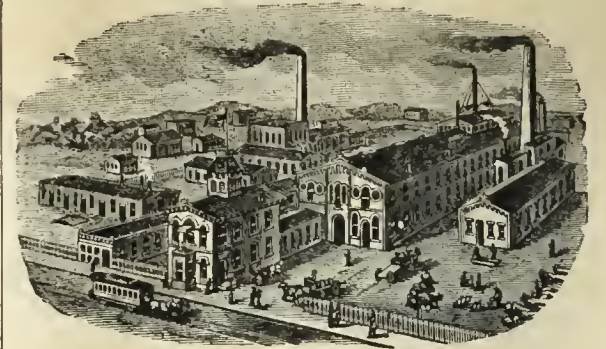

OFFICE AND WORKS,
938 to 954 River Street and 67 to 83 Vail Av.
TROY, N. Y.

Hydraulic Main Dip Regulators, also
Check Valves, Foot Valves, Yard-
wash and Fire Hydrants.
Send for Circulars.

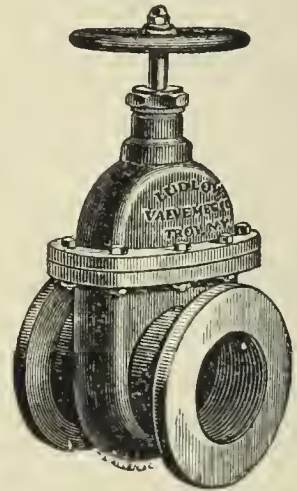

Valves.—Double and Single Gate, ½ in. to
48 in., outside and inside Screws. Indica-
tor, etc., for Gas, Water, Steam, and Oil.
Send for Circulars.

How to Reduce Leakage to Its Minimum.

USE

HOPPER'S AUTOMATIC DIFFERENTIAL GAS GOVERNOR.

Needs No Attention. Simple, Reliable, Perfectly Automatic.
"Nearly Thirty in Use."

BYE-PASSES, DRY CENTER VALVES, PRESSURE REGISTERS. Also, GOVERNORS FOR
STREET MAINS, *NOT DIFFERENTIAL*, and for EXHAUSTERS, GAS ENGINES, etc.

Our new Bye-Pass is threefold in its action—passes gas through, or bye-passes, or shuts off entirely.
Correspondence solicited; information given. Send for circulars and testimonials.

T. C. HOPPER & CO., - - No. 227 Wood Street, Philadelphia, Pa.

G. S. COOK, Pres. THOS. DAVENPORT (late Davenport Bros.), Sec. & Treas

BARTLETT

Street Lamp Mfg. Co.

MANUFACTURERS OF

Bartlett's Patent

GLOBE LAMPS,

FOR

Streets, Parks, Railroad Stations, Public
Buildings, Etc.

LAMP POSTS A SPECIALTY.

Office and Salesroom

40 & 42 College Place, N. Y. City.

Gas Companies and others intending to erect lamps and posts
will do well to communicate with us.

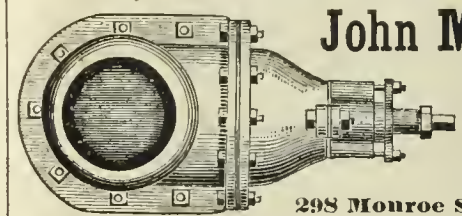
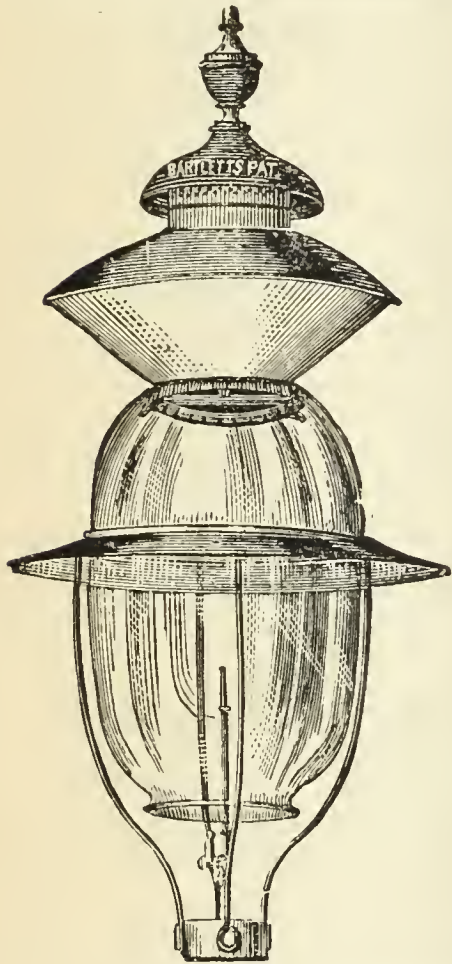

John McLean

Man'ufacturer of

**GAS
VALVES.**

298 Monroe Street, N. Y.

MITCHELL, VANCE & CO.,

MANUFACTURERS OF

Chandeliers

and every description of

GAS FIXTURES.

Also manufacturers of Fine Gilt Bronzes and Marble Clocks,
warranted best time-keepers. Mantel Ornaments, etc.

Salesrooms, 836 Broadway, N. Y.

Special Designs furnished for Gas Fixtures for Churches, Public
Halls, Lodges, etc.

GAS AS A SOURCE OF LIGHT, HEAT, AND POWER.

By C. J. R. HUMPHREYS

A Pamphlet of twenty-nine pages, treating of the use of Gas as a
source of Light, Heat, and Power.

DESIGNED FOR DISTRIBUTION BY GAS COMPANIES AMONG THEIR CUSTOMERS AND OTHERS.

Price, 10 cents each, \$5 per 100, \$50 per 1,000.

Gas Companies can have their own imprint placed on cover without extra charge. All orders to be sent to

A. M. CALLENDER & CO.,

No. 42 Pine Street, N. Y. City.

GAS STOVES.

GAS STOVES.

GAS STOVES.

THE AMERICAN METER CO.,

MANUFACTORIES,

508 to 514 West Twenty-second St., N. Y.

Arch and Twenty-second St., Phila.

Nos. 244 & 246 North Wells Street, Chicago, Ill.

AGENCIES,

No. 177 Elm Street, Cincinnati, Ohio.

Nos. 122 & 124 Sutter Street, San Francisco Cal

No. 810 North Second Street, St. Louis, Mo.

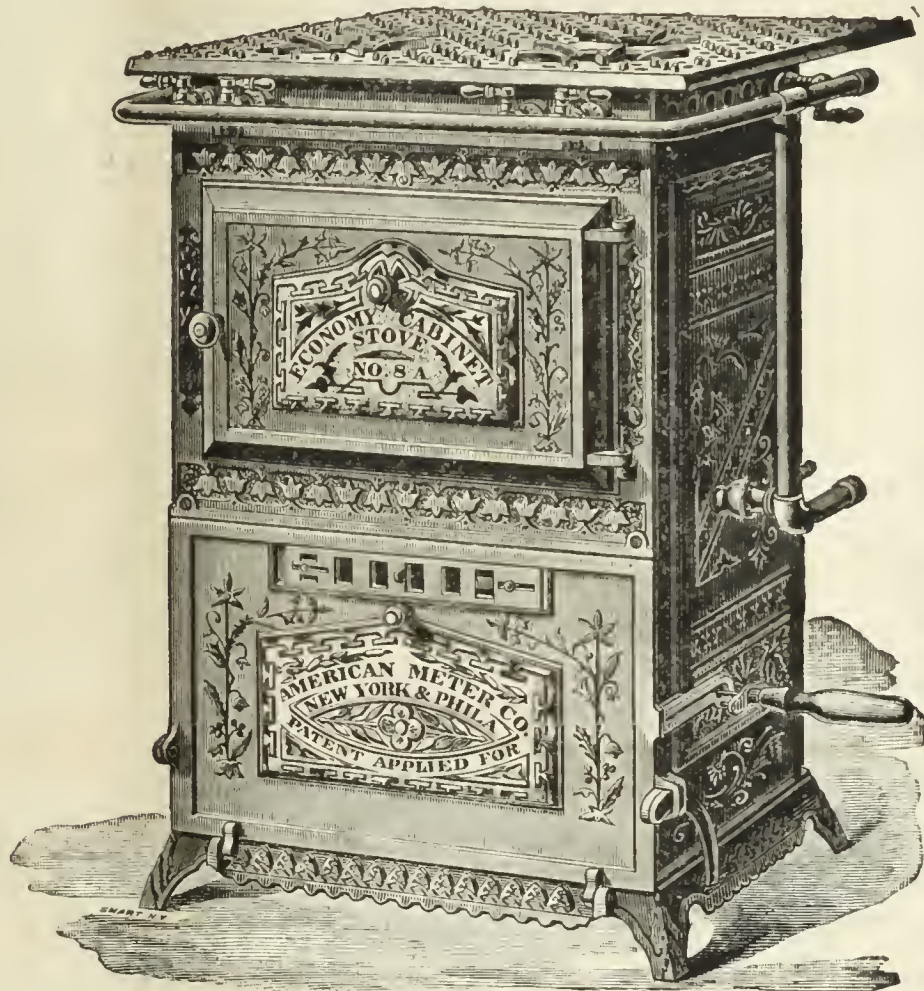

New Design Cast Iron "Economy" Cabinet Stoves.—With Open or Closed Top.

THE COMPANY MANUFACTURES

GAS STOVES FOR COOKING AND HEATING PURPOSES,

In All Sizes, for Domestic, Restaurant, and Hotel Use.

Also,

A Variety of Apparatus for Mechanical Purposes, Using Gas as Fuel.

These Stoves may be seen in operation at our Retail Store, No. 223 Sixth Avenue, N. Y. Call and examine.

SEND FOR ILLUSTRATED CATALOGUE SHOWING THE VARIOUS STYLES AND SIZES.

RETORTS AND FIRE BRICK.

J. H. GAUTIER & CO.,

CORNER OF

GREENE AND ESSEX STREETS,
JERSEY CITY, N. J.

MANUFACTURERS OF

Clay Gas Retorts,
Gas House Tiles,
Fire Bricks, Etc. Etc.Ground Clay, Fire Brick and
Fire Sand in Barrels,J. H. GAUTIER.
C. E. GREGORY.T. B. GAUTIER.
C. E. GAUTIER.**BROOKLYN**Clay Retort & Fire Brick Works,
(EDWARD D. WHITE & CO.)Manufacturers of Clay Retorts, Fire Brick,
Gas House and other Tile.VAN DYKE, ELIZABETH, RICHARDS & PARTITION STS.
Office, 88 Van Dyke St., Brooklyn, N. Y.

RETORTS AND FIRE BRICK.

LACLEDE FIRE BRICK MFG. CO.,

MANUFACTURERS OF

Fire Brick, Gas Retorts,

AND

ST. LOUIS STANDARD SEWER PIPE.

Blast Furnace and Cupola Linings, every description of Fire
Clay Material, Fire Clay Flue Linings, Chimney Tops
Dry Milled and Crude Fire Clays, etc.

OFFICE AND DEPOT

901, 903, and 905 Pine Street,
ST. LOUIS, MO.

ESTABLISHED IN 1845.

B. KREISCHER & SONS,

OFFICE FOOT OF HOUSTON ST., E. R., N. Y.

Gas Retorts,

TILES, FIRE BRICK.

AND EVERYTHING IN THE FIRE CLAY LINE.

RETORTS AND FIRE BRICK.

MANHATTAN

FIRE BRICK & ENAMELLED CLAY

RETORT WORKS.**ADAM WEBER.**

CLAY GAS RETORTS

AND RETORT SETTINGS

FIRE BRICKS, TILES, ETC.,

Office and Works, 15th Street and Avenue C., N. Y.



Works,

LOCKPORT STATION, PA.

—ESTABLISHED 1864.—

JAMES GARDNER, JR.,

Successor to WILLIAM GARDNER & SON.

Office, Rooms 19 & 20, Lewis Block,
PITTSBURGH, PA. P. O. Box 373.**Fire Clay Goods for Gas Works.**

CHAS. H. SPRAGUE & SON, No. 70 KILBY STREET, BOSTON, MASS., Agents for the New England States.

OFFICE, 418 to 422 East 23d St., New York.

ESTABLISHED 1856.

WORKS, PERTH AMBOY, NEW JERSEY.

HENRY MAURER & SON,
Excelsior Fire Brick & Clay Retort Works
CLAY GAS RETORTS, BENCH SETTINGS, FIRE BRICK, TILES, ETC.**CHICAGO**

Retort & Fire Brick Works,

OFFICE AND FACTORY,
Clark, Forty-Fifth, and La Salle Streets,
CHICAGO, ILL.

GEORGE C. HICKS, PRES. PAUL P. AUSTIN, SEC. & TREAS.

STANDARD

Clay Retorts and Settings.

BLOCKS & TILES

of every Shape and Size to Order.

Standard Fire Bricks.

GEROULD'S IMPROVED RETORT CEMENT.A Cement for patching retorts, putting on mouthpieces, and
making up all bench-work joints. This Cement is mixed ready
or use. Economic and thorough in its work. Fully warranted
no stick. For recommendations and price list address**C. L. GEROULD,**
Manchester, N. H.

Western Agent, H. T. GEROULD, Mendota, Ill.

OAKHILL**GAS RETORT & FIRE BRICK**

Works.

Proprietors,

PARKER-RUSSELL MINING & MFG. CO.

City Office, 711 Pine Street,
ST. LOUIS, MO.Our immense establishment is now employed almost entirely in
the manufacture of**MATERIALS FOR GAS COMPANIES.**We have studied and perfected three important points. Our re-
torts are made to stand changes of temperature, the strongest
heats of the furnace, and the abrasion of feeding and emptying.
Our customers are in almost every State of the Union, to all of
whom we refer.

THOS. SMITH, Prest. AUGUST LAMBLA, Vice-Prest. & Sup

BALTIMORE**RETORT & FIRE BRICK CO.**

MANUFACTORY AT

LDCUST PDINT, BALTIMDRE, MD.

Connection with the City by Telephone.

Clay Retorts, Blocks & Tiles,
FIRE BRICK, FIRE CLAY,
AND FIRE CEMENT.Red and Buff Ornamental Tiles and Chim-
ney Tops. Drain and Sewer Pipe (from
2 to 30 inches). Baker Oven Tiles
12 x 12 x 2 and 10 x 10 x 2.WALDO BROS., 88 WATER ST., BOSTON, MASS
Sole Agents the New England States.

EVENS & HOWARD,

916 Market St., St. Louis. Mo.

Works, Howard Station, Mo. Pacific R.R.

Fire Brick, Gas Retorts

AND

RETORT SETTINGS.

Sewer Pipe, 3 to 24 in. diameter.

Glass Pot Clay, Ground Fire Clay, in barrels and in bulk. All kinds of Fire Clay Goods.

Cincinnati Gas Retort & Fire Brick Works.

—ESTABLISHED 1872.—

CHAS. TAYLOR,

MANUFACTURER OF

Gas Retorts, Fire Brick, and Tile.

Blast Furnace Linings, Cupola Blocks, Boiler Tiles, Grate Settings, and Stove Linings. Fire Cement, Fire Clay, Fire Sand, and all other Fire Clay Goods.

Branch Works, New Cumberland, W. Va.

GENERAL OFFICE AND WORKS,

Burns St., Cincinnati, Ohio.

EMIL LENZ,

2 & 4 Stone St., N. Y. City.

CLAY GAS RETORTS

(ENAMELED.)

Fire Brick, Blocks & Tiles.

FIRE CEMENT, RETORT ENAMEL, RETORT CEMENT, ETC., ETC.

Regenerative and Half-Regenerative Benches.

PORTLAND CEMENT.

Correspondence Respectfully Solicited.

THE GLOBE STREET LAMP.

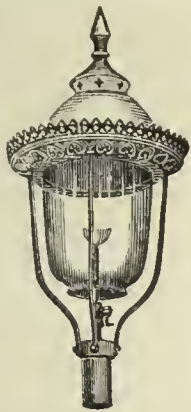

MINER'S PATENT STREET LAMPS.

Are adapted for use of Streets, Parks, Depots, Ferries, & Private Grounds.

WITH POSTS OR BRACKETS.

Jacob G. Miner,

No. 823 Eagle Ave., New York, N. Y.

PATENTS.

FRANKLIN H. HOUGH,

Solicitor of American & Foreign Patents

925 F. ST., WASHINGTON, D. C.

(NEAR U. S. PATENT OFFICE.)

Personal attention given to the preparation and prosecution of applications for Letters Patent. All business before the U. S. Patent Office attended to for moderate fees. No Agency in the United States possesses superior facilities for obtaining Patents, or for ascertaining the patentability of inventions. Copies of patents furnished for 25 cents each. Correspondence solicited.



STEPHEN A. MORSE, President.
GODFREY REBMANN, Vice-Pres.

M. B. DYOTT,
Superintendent.

EDWIN F. MORSE, Secretary.
CARLTON M. WILLIAMS, Treas.

STANDARD GAS LAMP CO.,

Office, 411 Cherry St. Factory, 1101, 1103 & 1105 Frankford Av.

Philadelphia, Pa.

It is to the interest of Gas Companies and Cities to use Dyott's Patent Champion Lamps, which give double the light with the same consumption of gas, and will save 50 per cent. over others in cost of keeping in repair. Gas Companies and others intending to erect Lamps of any description will do well to communicate with us. Special Drawings furnished and Estimates given on application upon Architects', Engineers' or our Draughtsmen's Plans.

Our Patent System of Instantaneously Lighting Gas (without electricity) for R. R. Depots is unequalled. Our High Candle Power Burner is superior to the Electric Light or any other High Candle Burner. We manufacture every description of Ornamental Lamps.

KLOENNE & BREDEL

IMPROVED REGENERATIVE FURNACES.

Self-Sealing Mouthpieces & Bridge-Pipes, Retort Houses,

WASHER-SCRUBBERS,

Gasholders, and Complete Gas Works.

Refers, by permission, to Mr. Eugene Vanderpool, of Newark, N. J.; Mr. E. G. Cowdery, of Milwaukee, Wis.; and Mr. Theo. Forstall, of Chicago, Ill. For further information apply to

FRED. BREDEL, 332 East 17th St., N. Y. City.

CHURCH'S REVERSIBLE TRAY



For Purifiers and Scrubbers.

OVAL OR RECTANGULAR SLATS.

FOR LIME OR IRON SPONGE.

MALLEABLE IRON CROSS BARS.

**Strongest! Most Durable!
Most Easily Repaired!**

MANUFACTURED BY

JOHN CABOT,

306 to 310 Eleventh Ave., N. Y. City.

MILLS' REVERSIBLE LIME TRAY,

AND

WOODWORK

Of Every Description

NEEDED BY GAS WORKS.

SEND FOR CIRCULAR AND PRICE LIST TO

GEORGE A. MILLS,

Canton Av. & President St., Baltimore, Md.

Ferric Oxide for Gas Purification.

Ferric Oxide, as ground, screened, and prepared by me for purifying purposes, has now been in use for several years by many of the gas works throughout the country, including Detroit, Chicago, Milwaukee, East Saginaw, Burlington (Iowa), Ann Arbor, etc. It has proved, as I believe, the **Most Effective and Economical Agent** now in use. I am prepared to furnish the Oxide by the 100 lbs. or in car load lots, and will be pleased to give price f.o.b. cars at Ann Arbor or at place of destination. Address

S. H. DOUGLAS, Prest. Ann Arbor (Mich.) Gas Light Co.

GAS AND WATER PIPES.

GAS AND WATER PIPES.

ENGINEERS.

SAM'L R. SHIPLEY, Pres.
HENRY B. CHEW, Treas.JAS. P. MICHELLON, Sec.
WM. SEXTON, Supt.

P. D. WANNER, Chairman. A. H. MELLERT, Sec. & Treas.

GLOUCESTER IRON WORKS,
GLOUCESTER CITY, N. J.

Cast Iron Gas & Water Pipes, Stop Valves, Fire Hydrants, Gasholders, &c.
Office No. 6 North Seventh Street, Philadelphia.

MATTHEW ADDY, President.

W. L. DAVIS, Selling Agent.

GEO. P. WILSHIRE, Sec. & Treas.

Cincinnati and Newport Iron and Pipe Company,
NEWPORT, KY.

Lamp Posts

AND

BENCH CASTINGS

A Specialty.

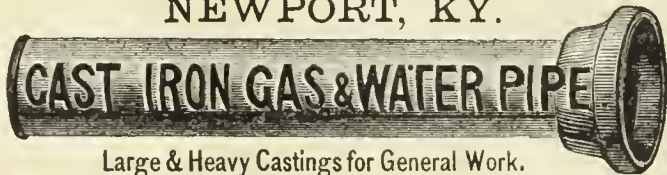

Large & Heavy Castings for General Work.
Manufacture Pipe from 2 to 48 inches. All work guaranteed first quality.

Branch

AND

SPECIAL CASTINGS

FOR GAS & WATER CO'S.

Pancoast & Rogers.**WROUGHT IRON PIPE,**

VALVES AND GATES,

Cast Iron Gas & Water Pipe.

28 Platt and 15 Gold St., New York.

Parson's Steam Blower,FOR IMPROVING BAD DRAUGHT IN BOILERS, AND FOR BURNING BREEZE
OR OTHER WASTE MATERIAL.**PARSON'S TAR BURNER,**

FOR UTILIZING COAL TAR AS FUEL.

PARSON'S AIR JET TUBE CLEANER,

FOR CLEANING BOILER TUBES.

These devices are all first-class. They will be sent to any responsible party for trial. No sale
unless satisfactory. Manufactured by the WATERTOWN STEAM BLOWER COMPANY.**H. E. PARSON, Supt., 42 PINE ST., N. Y.****The Management of Small Gas Works.**

By C. J. R. HUMPHREYS. Price, \$1.

A. M. CALLENDER & CO., 42 Pine St., N. Y.**MELLERT FOUNDRY & MACHINE CO., Ltd.**
Reading, Pa.Specials—Flange Pipe, Valves and Hydrants,
Lamp Posts, Retorts, etc.

General Foundry and Machine Work.

JOHN FOX, Selling Agent. 160 Broadway, N. Y.

THE OHIO PIPE COMPANY,

MANUFACTURERS OF

Cast Iron Gas & Water Pipe,

BRANCH AND SPECIAL CASTINGS.

Gas-House Bench Castings, Hydraulics, Lamp Posts, Flange Pipe
and Specials, Architectural Castings, Building Columns,
Joists, Cellar Grates, Sash Weights, etc.

GENERAL FOUNDERS AND MACHINISTS.

Columbus, Ohio.

M. J. DRUMMOND,

SPECIAL CASTINGS AND LAMP POSTS.

Equitable Building, 120 Broadway, N. Y.

JOS. R. THOMAS, C.E.,May be Consulted on all Mat-
ters Relating to Gas Works
and Gas Manufacture.

ADDRESS THIS OFFICE.

WM. MOONEY

(Successor to WM. FARMER)

27 Pearl Street, N. Y. City.

(One door from Whitehall Street.)

CONTRACTOR FOR THE ERECTION OF GAS WORKS, OR

APPARATUS OF ANY CAPACITY. AGENT FOR

WM. FARMER'S PATENTS.

Plans and Specifications Furnished.

WM. HENRY WHITE,

CONSULTING AND CONSTRUCTING

Gas Engineer & ContractorEstimates, Plans, and Specifications furnished for new works or
extensions of existing works.

No. 32 Pine Street, New York City.

Correspondence solicited.

WM. GARDNER,**Gas Engineer,**

Lewis Block, Room 20, Pittsburgh, Pa.

Those who intend to make alterations in existing gas plants, or
who contemplate the erection of new works, will find it to their
interest to open correspondence with the above. Plans made
and estimates furnished.

GAS LAMPS.

SCRUBBERS AND CONDENSERS.

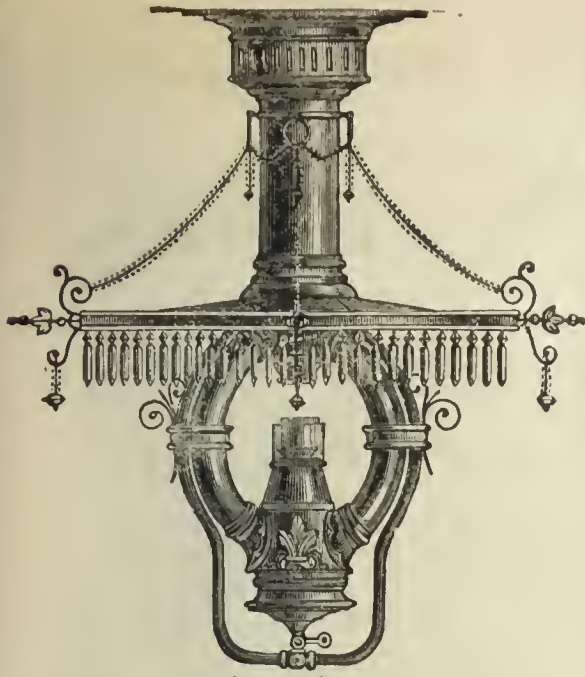

SIEMENS LAMP.

The Siemens and Lungren REGENERATIVE GAS LAMPS.

A System of Burning Gas whereby its Illuminating Power is Increased from 300 to 400 per ct. without the Expense, Trouble and Annoyance resulting from the use of Hydrocarbon Enriching Material.

The Siemens-Lungren Company received the only Silver Medal or Highest Award for Gas Burners at the "Novelties" Exhibition of the Franklin Institute, held at Phila., Oct., '85.

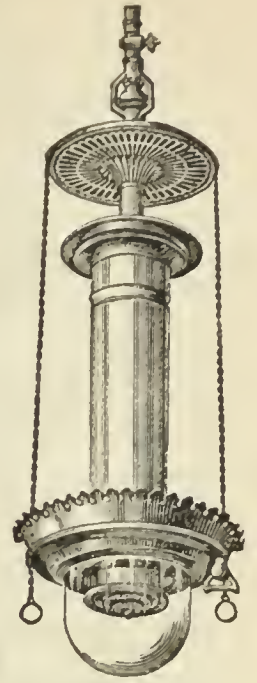

LUNGREN LAMP

THIRTEEN CANDLE POWER PER CUBIC FOOT OF GAS!

This result is obtained

SIMPLY BY THE SCIENTIFIC APPLICATION OF THE REGENERATIVE PRINCIPLE.

Consequently this largely increased illumination is always maintained without further cost and frequent attention.

THE SIEMENS-LUNCREN COMPANY,

N. E. Cor. 21st. St. and Washington Av., Phila., Pa.

THE PATENT "STANDARD" WASHER-SCRUBBER

(KIRKHAM, HULETT & CHANDLER PATENT.)

Has been adopted by gas companies in all parts of the world. Between 300 and 400 companies, with the enormous daily output of over 300,000,000 cubic feet, are now using it. "Standard" Washer-Scrubbers have been erected for the following gas light companies since Jan. 1, 1886:

WALLASEY, ENGLAND.....	750,000	cubic feet.	RICHMOND, SURREY, ENGLAND.....	1,500,000	cubic feet.
NEWARK, ENGLAND.....	350,000	"	BRIDGEPORT, U. S.....	500,000	"
BUFFALO, U. S. (MUTUAL).....	500,000	"	TORONTO, CANADA.....	1,000,000	"
BERLIN, GERMANY.....	1,250,000	"	HARTFORD, U. S.....	1,000,000	"
SO. BRISBANE, AUSTRALIA.....	300,000	"	DETROIT, U. S.....	750,000	"
LEEDS, ENGLAND.....	2,000,000	"	SINGAPORE, CEYLON.....	300,000	"
FURTH, GERMANY.....	400,000	"	BRUNSWICK, GERMANY.....	300,000	"
FREIBURG, GERMANY.....	200,000	"	LILLE, FRANCE.....	750,000	"
NINE ELMS, LONDON.....	3,000,000	"	CADIZ, SPAIN.....	300,000	"
MELBOURNE, AUSTRALIA (2).....	3,000,000	"	READING, ENGLAND.....	2,000,000	"
GLUCKAUF COKE WORKS, GERMANY.	200,000	"	LINCOLN, U. S.....	250,000	"
BOURNEMOUTH, ENGLAND.....	1,000,000	"	ST. LOUIS, U. S. (LACLEDE).....	1,000,000	"
			BROOKLYN, U. S.....	2,000,000	"
			BROOKLYN, U. S. (NASSAU).....	1,000,000	"
			DENVER, U. S.....	1,000,000	"

That this apparatus is really the *standard* is indicated by the following names of important houses who represent this invention in the different countries of the world:

FRANCE & BELGIUM, Mons. J. A. Berly, 31 Rue Boinod, Paris. HOLLAND & DUTCH COLONIES, Mess. W. Hoven & Zoon, Rotterdam.

GERMANY and AUSTRO-HUNGARY, Berlin-Anhaltische-Actiengesellschaft, Berlin, Moabit, and Dessau.

RUSSIA, Mr. F. Bley, Galernaya, 44, St. Petersburg. SPAIN, Mess. Nicolas, Chamon, Foiret & Cie., 29 Rue Claude-Vellefaux, Paris.

ITALY & MALTA, Sig. E. Canziani, 26 & 28 Portici, Vittorio Emmanuele, Genoa. Sig. Fratelli Scheuer, Via Chiaja, 124, Naples

NEW SOUTH WALES, Messrs. W. Coward & Sons, 143 Queen Victoria St., London.

NEW ZEALAND and VICTORIA, Messrs. G. D. Jennings & Co., 28 Gracechurch St., London.

Companies in the U. S. adopting this apparatus can now be assured of a market for the Ammoniacal Liquor at a remunerative price. Correspondence for purchase of "Standards" and Ammoniacal Liquor is solicited by the

GEO. SHEPARD PAGE, 69 WALL STREET, NEW YORK.

GAS WORKS APPARATUS AND CONSTRUCTION.

GAS WORKS APPARATUS AND CONSTRUCTION.

WORKS: { MILLVILLE, N. J.
FLORENCE, "
CAMDEN, "**R. D. WOOD & CO.,**OFFICES: { 400 CHESTNUT ST.,
PHILADELPHIA.**CAST-IRON PIPE** 1½ to 72 Inches in Diameter.**Water Machinery and Gas Apparatus.****HEAVY CASTINGS.**HOLDERS,

LAMP POSTS,

VALVES,

PURIFIERS,CONDENSERS,BENCH WORK,

METER CASES.

FLOORS AND ROOFS,

FLANGED PIPE,

FIRE HYDRANTS,

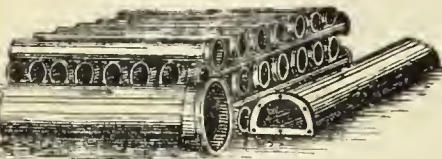
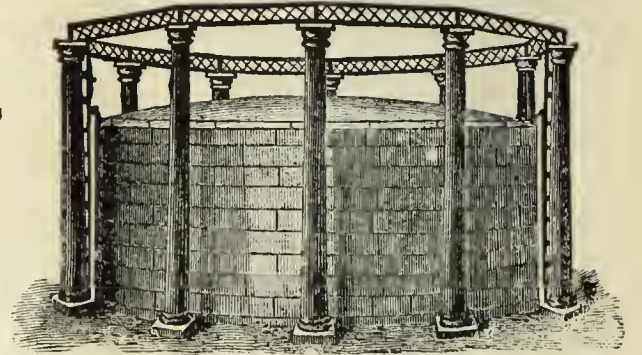
Estimates and Specifications for
NEW WORKS or **EXTENSIONS**
or **ALTERATIONS** of **OLD ONES.****SOUTHWARK FOUNDRY AND MACHINE COMPANY,**Successors to **MERRICK & SONS,****GAS APPARATUS,**Holders, Purifiers, Washers, Etc., Etc. Boiler and Tank Work. Steam Engines.
Hydraulic Machinery. Bessemer Plants, Etc.

Washington Ave. and Fifth Street, Philadelphia, Pa.

MORRIS, TASKER & CO.,

Limited,

Builders of Gas Works,

PHILADELPHIA PA.

GASHOLDERS, PURIFIERS, SCRUBBERS, CONDENSERS, EXHAUSTERS,

Bench Castings, Iron Roofs, Lamp Posts,

VALVES, STREET MAIN SPECIALS, ETC.,

MANUFACTURED BY

KERR MURRAY MANUFACTURING COMPANY.

From 1880 to 1886, inclusive, we erected Gasholders for the following cities, viz.:

Adrian, Mich.	East End Gas Co., Pitts-	Janesville, Wis.	New Castle, Pa.	Valparaiso, Ind.
Akron, Ohio.	burgh, Pa.	Johnstown, Pa.	Niagara Falls, N. Y.	Van Wert, Ohio.
Albuquerque, N. M.	East Saginaw, Mich.	Key West, Fla.	Osawatomie, Kans.	Wabash, Ind.
Altoona, Pa.	Elgin, Ills.	La Crosse, Wis.	Pittsburgh, Pa. (2)	Waco, Texas.
Anderson, Ind.	Evanston, Ills.	Lebanon, Ind.	Plainfield, Ind.	Waukesha, Wis.
Bellaire, Ohio.	Eufaula, Ala.	Lima, Ohio.	Portage City, Wis.	Wheeling, West Va.
Birmingham, Ala.	Frankfort, Ind.	Logan, Ohio.	Sedalia, Mo.	Wellington, Kans.
Bucyrus, Ohio.	Freeport, Ills.	Louisville, Ky.	Sheboygan, Wis.	West Pittsburgh, Pa.
Canton, Ohio.	Galesburg, Ills.	Mankato, Minn.	South Bend, Ind.	Xenia, Ohio.
Circleville, Ohio.	Grafton, West Va.	Mansfield, Ohio.	South Chicago, Ills.	Youngstown, Ohio.
Colorado Springs, Col.	Greensburg, Pa.	Marshalltown, Iowa.	Springfield, Ills.	Ypsilanti, Mich.
Danbury, Conn.	Huntington, Ind. (2)	Meridian, Miss.	Streator, Ills.	
Delaware, Ohio.	Ironton, Ohio.	Minneapolis, Minn.	Topeka, Kans.	
Delphos, Ohio.	Jamestown, N. Y.	Muskegon, Mich.	Uniontown, Pa.	

Under construction, 1887.

Arkansas City, Kans.	Grand Forks, Dakota.	Mobile, Ala.	Santa Fe, N. M.	Fuel Gas and Electric Engi-
Dallas, Texas.	Grand Rapids, Mich.	Pittsburgh, Pa.	Wichita, Kans.	neering Co., Pittsburgh, Pa.
El Paso, Texas.	La Crosse, Wis.			

Estimates, with Plans and Specifications, for new or the rebuilding of old works, furnished on application.
Correspondence solicited. Address**KERR MURRAY MANUFACTURING CO.,**

A. D. CRESSLER, General Manager.

FORT WAYNE, IND.

GAS WORKS APPARATUS AND CONSTRUCTION.

GAS WORKS APPARATUS AND CONSTRUCTION.

JAMES R. FLOYD,

(SUCCESSOR TO HERRING & FLOYD)

Oregon Iron Works,

531 to 543 West 20th St., N. Y.

Practical Builders of Gas Works,

MANUFACTURERS OF

**ALL KINDS OF CASTINGS
AND
APPARATUS FOR GAS-WORKS.**

BENCH CASTINGS

from benches of one to six Retorts each.

**WASHERS: MULTITUBULAR AND
AIR CONDENSERS; CONDENSERS;
SCRUBBERS**

(wet and dry), and

EXHAUSTERS

for relieving Retorts from pressure.

BENDS and BRANCHES

all sizes and description.

FLOYD'S PATENT

MALLEABLE RETORT LID.

PATENT

SELF-SEALING RETORT LIDS.

FARMER'S

PATENT BYE-PASS DIP-PIPE.

SABBATON'S PATENT

FURNACE DOOR AND FRAME.

BUTLER'S

COKE SCREENING SHOVELS.

GAS GOVERNORS,

and everything connected with well regulated Gas Works at low price, and in complete order.

SELLER'S CEMENT

for stopping leaks in Retorts.

N. B.—STOP VALVES from three to thirty inches—at very low prices.

Plans, Specifications, and Estimates furnished.

GAS vs. ELECTRIC LIGHT.

We would invite attention to the able and exhaustive argument of General A. Hickenlooper, President of the Cincinnati Gas Light and Coke Company, contained in a handsome pamphlet of 96 pages, entitled

"EDISON'S INCANDESCENT ELECTRIC LIGHTS FOR STREET ILLUMINATION. REPORT OF AN ARGUMENT DELIVERED BY A. HICKENLOOPER BEFORE THE COMMITTEE ON LIGHT, MUNICIPAL COUNCIL, CITY OF CINCINNATI, JULY 22, 1886."

This is a subject of special interest to all Gas Light Companies.

Prices.

25 copies..... \$7.50 100 copies..... \$22.50
50 copies..... 12.50 250 copies..... 50.00

A sample copy will be sent by mail on receipt of 50 cts.

A. M. CALLENDER, & CO., 42 PINE ST., N. Y. CITY.

THE CONTINENTAL IRON WORKS.

THOS. F. ROWLAND, Prest. WARREN E. HILL and CHAS. H. CORBETT, V.-Prests. THOS. F. ROWLAND, JR., Sec. & Treas.

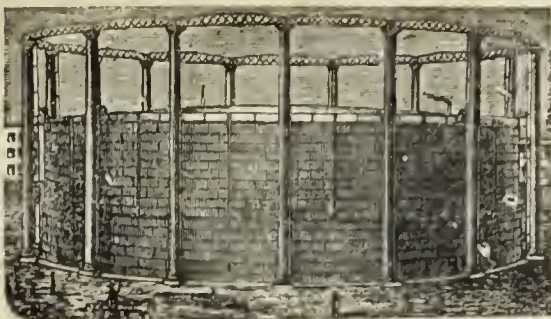

GAS HOLDERS OF ANY MAGNITUDE.

P. O. Station G., BROOKLYN, N. Y.

ENGINEERS AND MANUFACTURERS OF

Gas Holders

CONDENSERS, SCRUBBERS, VALVES,

PURIFIERS, SELF-SEALING RETORT LIDS,

Hydraulic Mains,

And all other articles connected with the manufacture and distribution of Gas.

H. RANSHAW, Prest. & Mangr. WM. STACEY, Vice-Prest. T. H. BIRCH, Asst. Mangr. R. J. TARVIN, Sec. & Treas.

STACEY MFG. CO.,

MANUFACTURERS OF

Single and Telescopic Gasholders,

IRON ROOFS, BRIDGES, LAMP POSTS,

Water and Oil Tanks, Coal Elevator Cars,

COKE CRUSHERS, BENCH CASTINGS,

And all kinds of Wrought and Cast Iron Work used in the erection of Coal and Oil Gas Works. Rolling Mill Machinery and Heavy Castings a Specialty.

Foundry:

33, 35, 37 & 39 Mill Street.

Wrought Iron Works:

16, 18, 20, 22, 24 & 26 Ramsey Street:

Cincinnati, Ohio.

1842. DEILY & FOWLER, 1887.

Laurel Iron Works.

Address, No. 39 Laurel Street, Philadelphia, Pa.

MANUFACTURERS OF

GASHOLDERS,

Single or Telescopic, with Cast or Wrought Iron Guide Frames.

Holders Built Since 1881:

- | | | | | |
|-----------------------|---------------------------|---------------------------|----------------------------|----------------------------|
| Scranton, Pa. (2d) | Hollidayshurg, Pa. | Jackson, Mich. | Montgomery, Ala. | New Castle, Pa. |
| West Point, N. Y. | Galveston, Texas (2d.) | Kalamazoo, Mich. (3d.) | Newport, R. I. | Long Island City, N. Y. |
| Fitchburgh, Mass. | Marlboro, Mass. | Glen Island, N. Y. | Portland, Oregon. | Macon, Ga. |
| New London, Conn. | Denver, Col. | Warren, Ohio. | Allegheny, Pa. (2d.) | York, Pa. |
| Derby, Conn. | Chicago, Ill. (West Side) | Bath, N. Y. | Atlanta, Ga. (2d.) | Chester, Pa. |
| Bridgeport, Conn. | Pittsburgh, Pa. (S. Side) | Lynn, Mass. | N.Y. City (Central Gas Co) | Hazleton, Pa. 2d. |
| Allegheny, Pa. (1st.) | Pawtucket, R. I. | New Bedford, Mass. | Lynchburg, Va. (2d.) | Novelties Exhib., Phila |
| St. Hyacinth, Can. | Brookline, Mass. | Waterbury, Conn. | Saylesville, R. I. | Staten Island, N. Y. |
| Norwalk, O. | Sherbrooke, Can. | Deseronto, Can. | Rondout, N. Y. | Saugerties, N. Y. |
| Brattleboro, V | Burlington, N. J. (2d.) | Hoosic Falls, N. Y. (2d.) | Atlantic City, N. J. | Clinton, Mass. (Lan. Mills |
| Waltham, Mass. (2d.) | Bridgeton, N. J. | Bethlehem, Pa. | Augusta, Ga. | Chattanooga, Tenn. |
| West Chester, Pa. | Bay City, Mich. | Atlanta, Ga. (1st.) | Waltham, Mass. (2) | Galveston, Texas. (3d.) |
| Baltimore, Md. | Erie, Pa. | Savannah, Ga. | Mahanoy City, Pa. | Omaha, Neb. |

SMITH & SAYRE MFG. COMPANY,

G. PORTER, Prest.

245 Broadway, N. Y.

CHAS. W. ISBELL, Sec'y.

Machinery & Apparatus for Gas Works

Drawings, Plans, and Estimates Furnished for the Improvement, Extension, or Alteration of Gas Works, or for the Construction of New Works.

Mackenzie's Patent Rotary and Steam Jet Gas Exhausters, Governors, Compensators, Condensers, Washers, Scrubbers. Isbell's Patent Automatic Street Pressure Governor, Gas and Water Valves, Hydraulic Main Dip Regulator, Bench Castings, etc. Purifying Boxes and "Standard" Scrubbers. Isbell's Patent Self-Sealing Retort Doors.

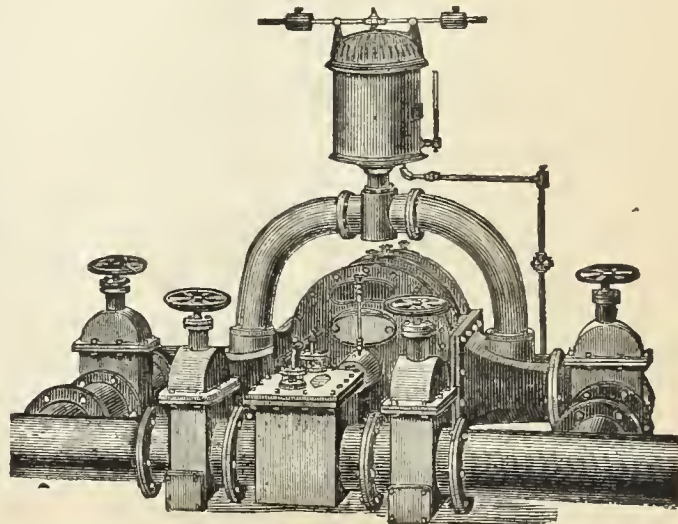

GAS COALS.

CANNEL COALS.

GAS ENRICHERS.

JAMES D. PERKINS.

PERKINS & CO.,

F. SEAVERNS.

General Sales Agents for

The Youghioghenny River Coal Company's**OCEAN MINE YOUGHIOGHENY GAS COAL.**

The Coal from the Ocean Mine (recently operated by *Messrs. W. L. Scott & Co.*, of Erie, Pa.,) is now used by all the leading Gas Companies in the United States from Maine to Texas, and is recognized as *the only reliable Youghioghenny Gas Coal.* (See Map on p. 87 of this Journal, Feb. 16, '85.)

P. O. Box 3695,
New York.**PERKINS & CO., 228 and 229 N. Y. Produce Exchange.**BEAVER STREET
ENTRANCE.**BRECKENRIDGE CANNEL,
OF KENTUCKY.**

This Colliery was re-opened in June, 1886, since which date the Cannel has been delivered to over sixty of the leading Gas Companies in this country and in Europe. As an enricher ONE TON of this Cannel will do the work of TWO TONS of any other available Cannel, and is more economical than Naptha or Oil of any character. It can be delivered in parcels of one car load or more to any point in the United States or Canada.

(See AMERICAN GAS LIGHT JOURNAL, June 16, '86, pp. 346-7.)

P. O. Box 3695,
New York.**PERKINS & CO., 228 and 229 N. Y. Produce Exchange**BEAVER STREET
ENTRANCE.**JAMES & WILLIAM WOOD,****Gas and Cannel Coal Contractors,**

No. 40 St. Enoch Sq., Glasgow. No. 2 Talbot Court, London.

Proprietors of the **BATHVILLE COLLIERIES** (which produce the celebrated **BOGHEAD CANNEL**), Shields, Shieldmuir, Drumpeller, and other Collieries. This Firm offer

STANDARD CANNELS,**Unequaled as Gas Enrichers.**

Analyses, prices, and all further information furnished on application to

Agency for U. S., Room 93, Nos. 2 & 4 Stone St., N.Y. City.

The Standard Oil Company,

REFINERS OF

NAPTHA AND GASOLINES.

ALSO MANUFACTURERS OF

A Special Grade of Naptha for
Gas Companies**FOR ENRICHING COAL GAS.**

Correspondence solicited.

No. 43 Euclid Avenue, Cleveland, Ohio.

To Gas Companies.We make to order **CAP BURNERS** to burn any amount under a stated pressure. Send for samples.Also, **SERVICE CLEANERS, DRIP PUMPS, and STREET MAIN PROVING APPARATUS.****C. A. GEFROER,**

248 N. 8th Street, Phila., Pa.

GOODWIN'S DIRECTORY**OF THE GAS LIGHT COMPANIES of the UNITED STATES & CANADA.**Price, **\$10.00.**

Orders may be sent to

A. M. CALLENDER & CO., No. 42 Pine Street, N. Y. City.

COKE CRUSHERS.

GAS COALS.

GAS COALS.

Newburgh Orrel Coal Co.,

MINERS AND SHIPPERS OF

Mountain Brook Steam and Smithing Coals,

AURORA, TYRCONNELL & PALATINE GAS COALS.

Foundry & Crushed Coke Shipped Direct from Ovens

Mines Situated at

Newburgh, Flemington & Fairmont, W.Va.

HOME OFFICE,

33 S. Gay St., Baltimore.

CHAS. MACKALL, Gen. Mangr.

CHAS. W. HAYS, Agent in New York,

Room 147, WASHINGTON BUILDING, No. 1 Broadway.

Shipping wharves at Locust Point, Baltimore.

THE DESPARD COAL COMPANY

OFFER THEIR SUPERIOR

DESPARD COAL

To Gas Light Companies and Manufacturers of Fire Clay Goods Throughout the Country.

ROUSEL & HICKS, } AGENTS. { BANGS & HORTON, }
71 Broadway, N. Y. } 16 Kilby St., Boston.

Mines in Harrison Co., West Va. Wharves, Locust Point, Balt.

Company's Office, 15 German St., Baltimore, Md.

Among the consumers of Despard Coal we name: Manhattan Gas Light Co., N. Y.; Metropolitan Gas Light Co., N. Y.; Jersey City, (N. J.) Gas Light Co.; Washington (D. C.) Gas Light Co.; Portland (Maine) Gas Light Co. Reference to them is requested.

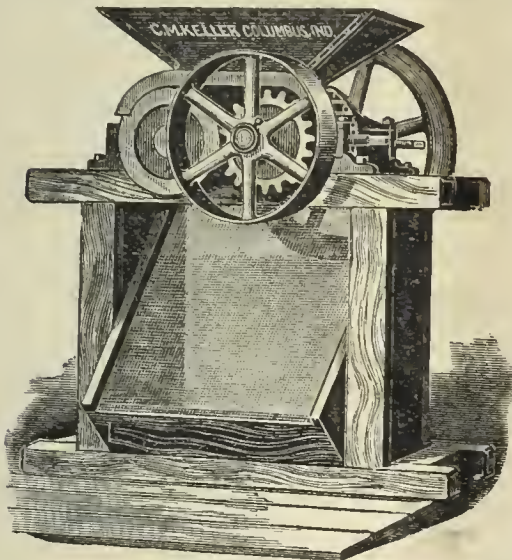

Keller's Adjustable Coke Crusher.

SIMPLE, STRONG, AND DURABLE.

C. M. Keller, Sec. & Supt. Gas Lt. & Coke Co. Columbus, Ind.

Correspondence Solicited.

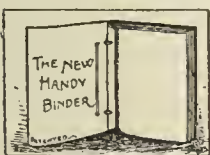

THE NEW HANDY BINDER.

This article may be described as elegant in appearance, strong, durable, and possessing many special qualities of its own. It allows the opening of the pages perfectly flat, whether one or several numbers are in the binder. Any number can be taken out and replaced without disturbing the others. The papers are not mutilated for subsequent binding in permanent form. The binder is supplied with gilt side title, and is an ornament to any desk or reading table. The JOURNAL, filed in the Handy Binder, becomes a volume of great value, always convenient for instant reference. Handy Binder, Postage paid, \$1.00.

A. M. CALLENDER & CO., 42 Pine St., N. Y.

THE PENN GAS COAL CO.

OFFER THEIR

Coal, Carefully Screened & Prepared for Gas Purposes.

Their Property is located in the Youghioghny Coal Basin, near Irwin and Penn Stations on the Pennsylvania Railroad, and on the Youghioghny River.

Principal Office:

209 SOUTH THIRD STREET, PHILA., PA.

Points of Shipment:

Pennsylvania Railroad Piers; Greenwich Wharves, Delaware River; Pier No. 1 (Lower Side), South Amboy, N. J.

Chesapeake & Ohio Railway Coal Agency,

FOR THE SALE OF THE

Superior Kanawha Gas Coals, Cannelton Cannel, Also, SPLINT AND STEAM COALS,

From the Kanawha and New River Regions, on the line of the Chesapeake & Ohio R'way.

C. B. ORCUTT, Sales Agent. | OFFICE, 150 BROADWAY, N. Y.

FRANCIS H. JACKSON, Prest. EDMUND H. MCCULLOUGH, V.-Prest. CHAS. F. GODSHALL, Treas. H. C. ADAMS, Sec.

THE WESTMORELAND COAL CO.

Chartered 1854.

Mines situated on the Pennsylvania and the Baltimore and Ohio Railroads, in Westmoreland County, Penn.

POINTS OF SHIPMENT:

PHILADELPHIA, BALTIMORE, SOUTH AMBOY, N. J., WATKINS (SENECA LAKE), N. Y.

Since the commencement of operations by this Company its well-known Coal has been largely used by the Gas Companies of New England and the Middle States, and its character is established as having no superior in gas giving qualities, and in freedom from sulphur and other impurities.

Principal Office, 224 South 3d St., Phila., Pa.

A. M. SCOTT, PRESIDENT. A. DEMPSTER, C.E., SECRETARY. W. K. GILLESPIE, TREASURER.

MONONGAHELA AND PETERS CREEK GAS COAL CO.,

PRODUCERS OF

Coal Bluff Gas Coal.

MINES LOCATED ON THE MONONGAHELA DIVISION OF THE PENNSYLVANIA RR., IN THE CENTRAL PORTION OF THE PITTSBURGH COAL FIELD.

Points of Shipment—Buffalo, Cleveland, Erie, Chicago, New Orleans.

Since the introduction of Coal Bluff Gas Coal it has taken rank among the few first-class Gas Coals, and acknowledges no superior in gas-giving qualities, ease of working, quality of coke, and freedom from impurities.

Milwaukee Agents, F. R. BUELL & CO., - - - Milwaukee, Wis.

General Office, 43 Sixth Ave., Pittsburgh, Pa.

GAS METERS.

GAS METERS.

GAS METERS.



INTERNATIONAL--1876--EXHIBITION.

The U. S. Centennial Commission

HAVE DECREED AN AWARD TO

HARRIS, GRIFFIN & CO.,

Twelfth and Brown Streets, Philadelphia, Pa. No. 49 Dey Street, N. Y. City, and No. 75 North Clinton Street, Chicago, Ill.

FOR THE FOLLOWING REASONS :

The Exhibit consists of a Series of METERS from the Largest Size Station Meters for the use of the MANUFACTURE OF GAS, to those for the use of the ORDINARY CONSUMER. The Instruments are WELL MADE, RELIABLE as to INDICATION, and embody a number of sundry improvements which, with the general character of the Exhibit, entitle the whole to commendation.

Attest—J. L. CAMPBELL,
Secretary, pro-tem.

Signed—A. T. GOSHORN,
Director General

J. R. HAWLEY,
President



Dry Gas Meter.

NATHANIEL TUFTS,

No. 153 Franklin Street, Boston, Mass.,

MANUFACTURER OF

DRY GAS METERS.

Station Meters of any Capacity.

Test and Experimental Meters, Pressure Registers, Pressure Gauges,
Pressure and Vacuum Gauges.

METER PROVERS, PHOTOMETERS, STREET LANTERNS, ETC., ETC.

Patent Cluster Lanterns for Street Illumination.

With 39 years' experience and the best facilities for manufacturing, is enabled to furnish reliable work and answer orders promptly.

SCIENTIFIC BOOKS.

We are prepared to furnish to Gas Managers, and others interested in the topics treated of, the following books, at prices named :

KING'S TREATISE ON THE MANUFACTURE OF COAL GAS. Three vols.; \$10 per vol.	PRACTICAL TREATISE ON HEAT, by THOMAS BOX. Second edition. \$5.	THE GAS MANAGER IN THE LABORATORY, by a Practica Student. 8vo., Cloth. \$1.50.
GAS MANUFACTURE, by WILLIAM RICHARDS. 4to., with numerous Engravings and Plates, in Cloth binding. \$12.	GAS WORKS—THEIR ARRANGEMENT, CONSTRUCTION, PLANT, AND MACHINERY. \$8.	THE DOMESTIC USES OF COAL GAS, AS APPLIED TO LIGHTING, by W. SUGG. \$1.40.
THE GAS ANALYST'S MANUAL, by F. W. HARTLEY. \$2.50.	COAL; ITS HISTORY AND USE, by PROF. THORPE. \$3.50.	DISTILLATION OF COAL TAR AND AMMONIACAL LIQUOR by GEO. LUNGE. \$8.50.
TECHNICAL GAS ANALYSIS. \$2.80.	THE GAS WORKS OF LONDON, by COLBURN. 60 cents.	A TREATISE ON THE COMPARATIVE COMMERCIAL VALUES OF GAS COALS AND CANNELS, by D. A. GRAHAM 8vo., Cloth. \$3.
GAS MANAGER'S HANDBOOK, by THOS. NEWBIGGING. \$4.80.	THE GAS FITTER'S GUIDE, Showing the Principles and Practice of Lighting with Coal Gas, by JOHN ELDREDGE. 40 cents.	GAS AS A SOURCE OF LIGHT, HEAT, AND POWER, by C. J. R. HUMPHREYS. 10 cents.
GAS CONSUMER'S GUIDE. \$1.	GAS WORKS, AND MANUFACTURING COAL GAS, HUGHES. \$2.20.	GAS COMPANIES DIRECTORY. \$10.
A GUIDE TO GAS LIGHTING. 40 cents.	THE MANAGEMENT OF SMALL GAS WORKS, by C. J. R. HUMPHREYS. \$1.	GAS VERSUS ELECTRIC LIGHT. 50 cents.
GAS MEASUREMENT AND GAS METER TESTING, by F. W. HARTLEY. \$1.60	MANUAL FOR GAS ENGINEERING STUDENTS, by D. LEE, 40 cents.	PURIFICATION OF COAL GAS, by R. P. SPICE. 8vo. \$3.
GAS CONSUMER'S HANDBOOK, by WILLIAM RICHARDS, C.E.; 18mo., Sewed. 20 cents.	HOW TO MANAGE GAS, by F. WILKINS. Paper. 20 cents.	
A PRACTICAL TREATISE ON GAS AND VENTILATION with Special Relation to Illuminating, Heating, and Cooking by Gas, by E. E. PERKINS. \$1.25.		

The above will be forwarded by express, upon receipt of price. We take especial pains in securing and forwarding any other Works that may be desired, upon receipt of order. All remittances should be made by check, draft, or post office money order.

A. M. CALLENDER & CO., No. 42 Pine Street, New York.

KING'S TREATISE ON COAL GAS.

The most complete work on Coal Gas ever published. Three vols., bound \$30.

A. M. CALLENDER & CO., No. 42 Pine Street, New York.

GAS METERS.

GAS METERS.

GAS METERS.

GEO. J. MoGOURKEY, Pres. WM. H. MoFADDEN, Vice-Pres. (Phila.). WM. N. MILSTED, Gen. Supt. & Treas. (New York). WM. H. DOWN Sec.

AMERICAN METER COMPANY,

WET AND DRY GAS METERS.

PRESSURE REGISTERS.

METER PROVERS.

STATION METERS.

PRESSURE & VACUUM REGISTERS.

PORTABLE TEST METERS.

EXHAUSTER GOVERNORS.

PRESSURE & VACUUM GAUGES.

EXPERIMENTAL METERS.

DRY CENTRE VALVES.

ORESSON GAS REGULATORS.

AMMONIA TEST METERS.

GOVERNORS FOR GAS WORKS.

MARSLAND WATER METERS.

BAR AND JET PHOTOMETERS.

Manufactories:

512 W. 22d St., N. Y.
Arch & 22d Sts., Phila.

GAS STOVES,

SUGG'S "STANDARD" ARGAND BURNERS,
SUGG'S ILLUMINATING POWER METER,
Wet Meters, with Lizar's "Invariable Measuring" Drum.

Agencies:

177 Elm Street, Cincinnati.
244 & 246 N. Wells Street, Chicago.
810 North Second Street, St. Louis.
122 & 124 Sutter St., San Francisco.

HELME & McILHENNY,

(Successors to Harris & Brother. Established 1818.)

GAS METER MANUFACTURERS,

CONTINUE AS HERETOFORE AT THE OLD ESTABLISHMENT,

Nos. 1339 to 1349 Cherry Street, Philadelphia, Pa.,

To Manufacture Wet and Dry Gas Meters, Station Meters, Experimental Meters, Meter Provers, Center Seals, Pressure Registers
GOVERNORS, INDICATORS, PHOTOMETERS, & ALL OTHER KINDS OF APPARATUS FOR USE IN GAS WORKS.

From our long practical experience of the business, and from our personal supervision of all work, we can guarantee all orders to be executed promptly
and in every respect satisfactorily.

WM. WALLACE GOODWIN, Pres. and Treas.

WM. H. MERRICK, V.-Pres.

S. L. JONES, Sec.

S. V. MERRICK, Supt.

THE GOODWIN GAS STOVE AND METER COMPANY,

Successors to W. W. GOODWIN & CO.

1012, 1014 and 1016 Filbert St., Phila., Pa.

142 Chambers St., New York.

76 Dearborn St., Chicago, Ill.

WALDO BROS., Agents, 88 Water St., Boston.

MANUFACTURERS OF THE "SUN DIAL" GAS STOVES, FOR COOKING AND HEATING PURPOSES.

Dry and Wet GAS METERS, Station Meters (Square, Cylindrical or in Staves) Glazed Meters, King's and Sugg's Experimental Met
Lamp Post Meters, Etc., Etc., Meter Provers (sizes 2, 5 and 10 feet), Pressure Guages of all kinds, Pressure Registers, Pressure and Vacuum Re
gisters, Pressure Indicators (sizes 4 inch, 6 inch and 9 inch), King's Pressure and Vacuum Gauges, Dry and Wet Centre Seals, Dry and Wet Gov
ernors, Exhauster Governors, Photometers of all descriptions. Letheby's Sulphur and Ammonia Test Apparatus complete—also
Testing and Chemical Apparatus of all kinds, and of the most perfect description, for all purposes relating to Gas.

GOODWIN'S IMPROVED LOWE'S JET PHOTOMETER.

Agents for Bray's Patent Gas Burners and Lanterns.

Special attention to repairs of Meters, and all apparatus connected with the business.
All work guaranteed first class in every particular, and orders filled promptly.

G. B. EDWARDS, Mang'r, New York.
E. H. B. TWINING, Mang'r, Chicago.
Represented by A. B. STANNARD.

D. McDONALD & CO.,

GAS METER MANUFACTURERS.

(Established 1854.)

51 Lancaster St., Albany, N. Y. 34 & 36 West Monroe St., Chicago, Ill.

STATION METERS, EXPERIMENTAL METERS, METER PROVERS, PRESSURE & VACUUM REGISTERS, PRESSURE GAUGES, ETC.

Also STAR GAS STOVES, RANGES, and HEATING STOVES.

We use only the very best materials, and employ the most skilled labor, and by our long experience (32 years) and personal supervision of every detail, we
feel justified in assuring the public that our goods will give perfect satisfaction. Every Meter emanating from our establishment will bear the State Inspector's
BADGE, and will be fully warranted by us. Our Annual and Calendar will be sent to Gas Companies upon application.

GAS ENGINES.

GAS ENGINES.

GAS ENGINES.

THE "OTTO" GAS ENGINE.

Guaranteed to Consume 25 to 75 Per Cent. LESS GAS than **ANY** OTHER GAS ENGINE DOING THE SAME WORK.

TWIN ENGINES Impulse every revolution.
THE STEADIEST RUNNING GAS ENGINE YET MADE.

ENCINES AND PUMPS COMBINED,

For Hydraulic Elevators, Town Water Supply, or Railway Service.

Special Engines for Electric Light Work.

OVER 15,000
IN USE.

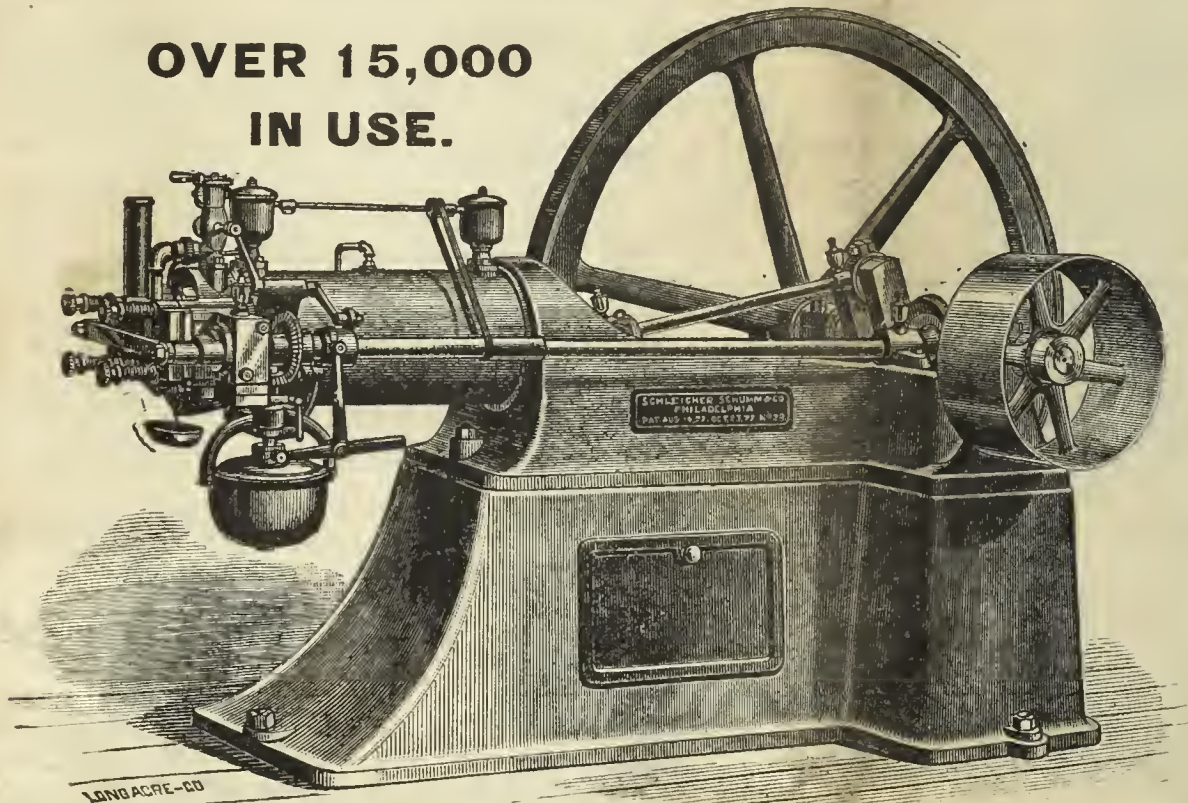

The Otto Gas Engine is now consuming, at a moderate computation, 2000 millions cubic feet of gas per year, nearly all of which is furnished during day time only.

**THE ONLY HIGHEST AWARD, ONLY GOLD MEDAL,
AT ELECTRICAL EXHIBITION, PARIS, 1881.**

MADE IN SIZES FROM 1 TO 25 HP. INDICATED.

FOR PARTICULARS, PRICES, ETC., APPLY TO

SCHLEICHER, SCHUMM & CO.,

Works:

N. E. Cor. 33d & Walnut Sts., Phila., Pa.

Branch Office:

130 Washington Street, Chicago, Ill.

THE AMERICAN

GAS LIGHT JOURNAL

REDMAN & KENNY, N.Y.

PUBLISHING OFFICE No. 42 PINE STREET

DEVOTED TO THE INTERESTS OF ILLUMINATION, VENTILATION, WATER SUPPLY AND DISTRIBUTION, & GENERAL SCIENCE.

VOLUME XLVII.—No. 1.
Whole No. 673.

NEW YORK, SATURDAY, JULY 2, 1887.

{ \$3 PER ANNUM,
IN ADVANCE.

A. M. CALLENDER & CO., Proprietors. C. E. SANDERSON, Manager.
JOS. R. THOMAS, C.E., Editor. T. J. CUNNINGHAM, Asst. Editor.

ENTERED AT THE POST OFFICE AT NEW YORK, N. Y.
AS SECOND CLASS MATTER.

Published on the 2d and 16th of each month, at No. 42 Pine Street, N. Y.

Terms of Subscription, Including Postage.—For the United States and Canada, \$3 per annum. European countries, \$3.50 (15 shillings—18 francs). All payments to be made in advance. Single copies, 15 cents.

Remittances should be made either by post-office order, registered letter, or bank draft on New York, payable to the order of A. M. Callender & Co.

Correspondence.—Wishing to make this JOURNAL a gazette of intelligent discussion to those of our readers who may wish to gain or give information on the subjects to which its columns are devoted, correspondence is solicited for publication from all who make the study of those subjects a pleasure or a profession.

The American News Company, Nos. 39 and 41 Chambers street, New York, are agents for this JOURNAL. Newsdealers will send orders to them.

Collections are invariably made directly from this office, for subscriptions, advertisements, etc. We have agents to solicit the same, but they are not authorized to receipt for money.

Books.—We will forward by express, at publisher's lowest rates, any book—scientific or otherwise—to any address in the United States or Canada. No books will be sent C. O. D.

PROGRESS SCORED IN 1887.

Now that the first half of 1887 has fulfilled its part in the making of history, perhaps a slight glance at the lines which record that history may reveal something of interest to the workers in the gas field. The first and most important query to be answered is that concerning the quantities of gas sent out as compared with the output for the first half of '86. From the best sources of information at our command, and these are perfectly reliable, we are in position to say that the increase in this respect has been little short of marvellous. Perhaps the greatest gain, speaking about the Eastern and middle sections of the country, occurred in New York city, for here the entire resources of the huge plants had to be called upon to meet the demand for light. Of course, the metropolitan conditions were somewhat abnormal, but we nevertheless think, even were ordinary conditions alone prevalent, that the increased traffic in gas would have furnished food for surprise. Boston reports also go to show that the gas makers of the East have had their time fully engaged in answering the demands of their consumers. And so it seems to have been throughout the country. In fact positive proof of the increase is furnished in the wonderful activity that now prevails in every direction. From every quarter and section we have circumstantial accounts of enlargements and betterments now being made to existing plants, which work is being prosecuted simply because of the desire to securely hold the advance of the past and to provide for the drain of the future. This activity bespeaks the confidence of the gas men in the stability of their business, and also vouches for their ability to hold the field against all comers. In the meantime one branch of electric lighting does not seem to have received any great setback. On the contrary much progress appears to have been made by the arc electricians, who, by-the-way, now that they have abated somewhat the extravagance of their original claims, seem to achieve greater success with their nearer approach to truthfulness. Perhaps the electrical promoters of this city see their way clear towards making a profit in supplying arc lights for purposes of public or street illumination at the rate of 25 cents each per night, and to keep them alight on an average of 4,000 hours per annum. Certainly, if they can do so, profitably they are in position to wrest the great bulk of the city's lighting from the gas companies, which might, after all, not be a great loss to the latter, since it would be far cheaper for the gas men (in consideration of the price received per lamp per annum) to forego the lighting of the streets than to institute and perfect huge plant extensions to meet the increasing demands of their ordinary consumers. Although the arc lighting advocates have scored an advance, the exponents of the incandescent system do not seem to have kept pace with their more fortunate brethren. Taking the Edison Central station in the lower part of this city as a guide, we do not believe that its controllers are now in possession of as large a business as they were a twelvemonth ago; but whether so or not the fact remains that the increase in the quantity of gas sent out from the New York station of the Consolidated Gas Light Company—which is the principal source of gas supply in the district operated in by the Edison Company—during the twelvemonth has been little short of phenomenal. While we think that, as at present carried on, gas companies have little to fear from competition with incandescent electric lighting, we are nevertheless inclined to adhere to the view ex-

CONTENTS.

An Asterisk (*) denotes an illustrated article.

EDITORIALS—	
Progress Scored in 1887.....	1
Obituary—Francis E. Harrison.....	2
The Electric Light and Plants.....	2
Tenth Annual Meeting of the Western Gas Association—Official Report—Continued from Vol. XLVI., page 380.....	2
A Preliminary Attack on the Question-box—"What is the Best Way to Fight the Electric Light?"—Second Day, Morning Session—Report of Special Committee on the Proposed Formation of an American Gas Institute—Mr. Watts Offers a Resolution—*The Rule of the Inverse Squares, by B. E. Chollar, of Topeka, Kas.	
Spectroscopical Test of Tar Colors.....	8
Special English Correspondence.....	9
The Forthcoming Meeting of the Gas Institute—Jubilee Rejoicings—The Electric Light and Plant Life—Gas for Cooking and Heating—At the Exhibitions.	
Notes from the West, by "Retort".....	10
ITEMS OF INTEREST FROM VARIOUS LOCALITIES.....	
An Explosion at Rutland, Vt.—A Hint or Two from Norfolk, Va.—A Tribute to the Memory of the Late Evan T. Jones—A Summary of the Work of a Busy Firm—Annual Meeting, American Water Works Association—Down They Go—The Water's Frisky Ways at Johnstown, Pa.—Branching Out at Jamaica Plain, Mass.—Bought Them Out—Likewise at Lynn, Mass.—Gas for North Abington and Whitman, Mass.—Annual Election, Newark (N. J.) Gas Light Company—Relief Granted—Annual Election, Pawtucket, R. I.—Connelly & Co., Limited—The Standard Gas Light Company—An Item from Owasso, Mich.—The Proposed New Company at Springfield, Mass.—Mr. L. J. Howard is not Afraid of the Germanic—Capital Increased—The Exact Figures—The New Works of the Denver (Col.) Gas Company—Cheaper Gas for Leavenworth, Kas.—To Use the Jarvis Boiler Setting—Glad to Hear it, Bro. Tracy—Killed by Electricity—New Gas Company—To Make the Korting Gas Engine—Tyler (Texas) to Have Gas Works—They Blew up the Gas Main—Cheaper Gas for Warren, Ohio—Calera (Ala.) to Have Gas.	
Cement from Blast Furnace Slag.....	13
The Market for Gas Securities.....	14

pressed in our first issue for the current year. That is, we believe good business policy would be subserved were gas companies to embark on the seas of joint supply. Now that several good systems, which permit of the supply of arc and incandescent lamps from the same circuit, are on the market, those gas men who employ such plants are in position to say to their customers, "Pay your money and take your choice, for we can supply you with any or all of three classes of lights." Still, there can be no hard-and-fast rule formulated in this respect which will apply satisfactorily to all places. Circumstance and locality make the necessity, and measures for relief or protection must be determined upon according to the necessity.

With the knowledge that steady and important progress has during the half year attended the main point of interest to the gas maker, and confident in the belief that the living half is to be a repetition of its departed fellow, we may extend our congratulations to the fraternity on the success of their efforts. Our Association gatherings have been fruitful of good work and effective in results; and even though death has been busy in the ranks those who dropped by the way have not taken from us the light of their example. When all is summed up the verdict in regard to the progress so far scored in '87 must be decidedly in favor of advance; and we believe that if tokens count for aught the gas men are pretty well pleased over the outlook for the balance of the year.

OBITUARY—FRANCIS E. HARRISON.

We are compelled to announce the death of Mr. Francis E. Harrison, late Treasurer of the New Haven (Conn.) Gas Light Company, whose demise occurred shortly before midnight of Tuesday, June 21, at his residence, No. 562 Chapel street, New Haven. Deceased, who through his entire business career had been a great worker, about two years ago suffered severely from an attack of nervous prostration, but unhappily he did not heed the warning of nature and continued to overtax his energies, forgetting, seemingly, that a limit is allotted to what any man may accomplish. In consequence of this disregard Mr. Harrison while seated before his office desk last September was stricken with apoplexy, and although his sturdy frame resisted the first blow, his subsequent condition was such as to give his family serious ground for alarm. Their forebodings were well founded, for on the Friday preceding final collapse the family physician notified them that the husband and father neared his end, and death claimed his own on the day above mentioned.

Deceased was born in New Haven, on Nov. 27, 1820, and graduated from Yale College with the class of 1849, President Dwight having been one of his classmates. His first years out of college were spent in teaching, and in preparing himself for the duties of a physician, but his studies in the latter direction were abandoned when he decided to accept a congenial position (the editorship of the Windham County *Telegraph*) that had been offered him. This new field, owing to the way in which he developed it, brought him into political notice, and in 1854 we find him occupying the position of Assistant Clerk to the Connecticut House of Representatives. He became Chief Clerk in the following year. Between 1856 and 1861 he was engaged in the banking business—first with the Elm City Bank, afterwards with the Litchfield Bank. In 1861 he was appointed to the Assistant Postmastership of his native city, remaining in that berth for eight years. In 1870 he was appointed Secretary to the New Haven and Derby Railroad, and to the duties of that position he added (1872) those of the Treasurership of the New Haven Gas Light Company. Beyond a doubt the strain on his mental system occasioned by the demands of such important trusts accounts for his comparatively early demise. Indeed, the wonder is that he withstood the unequal contest for such a length of time. Mr. Harrison was married in 1858, and a widow and five children survive him. In his death New Haven loses a public-spirited citizen, and the New Haven Gas Company a painstaking, trustworthy officer.

The Electric Light and Plants.

Engineering, seemingly betwixt fear and hope in regard to the point discussed, says that the Winter Palace of the Czar at St. Petersburg, is on festive occasions illuminated by electric light, and the palms and exotics used in decorating the banqueting and other rooms are believed to suffer from the blaze of light. The leaves turn yellow and dry up, then fall off. The action of the light is thought to be too intense and sudden on them after their transference from the conservatories where they are wintered. The late Dr. Siemens showed that electric light promoted the growth of plants, and it is difficult to understand how even the bright light of the Imperial galleries can have the reverse effect; but so it is reported. The subject is, however, open to further investigation, as there may be other influences at work than the mere illumination. If it should prove to be the latter the suddenness of the change from the dull greenhouses to the brilliant rooms may have to do with the problem, though it is somewhat singular that a similar effect has not been reported from other quarters.

[OFFICIAL REPORT.—Continued from Vol. XLVI., page 380.]

Tenth Annual Meeting of the Western Gas Association.

HELD AT ST. LOUIS, MO., MAY 11, 12 AND 13, 1887.

FIRST DAY—AFTERNOON SESSION—MAY 11.

A PRELIMINARY ATTACK ON THE QUESTION-BOX.

The President called attention to the fact that the hour for adjourning the afternoon session was close at hand, and suggested that, instead of proceeding with the reading of papers, the Question-Box be opened and a portion of its contents be discussed. The suggestion met with approval, whereupon Secretary Littleton unsealed the box and drew the following query therefrom:

"What is the best way to fight the electric light?"

The question was thus discussed—

Mr. Scofield—Sell gas so cheaply that the electrical promoters cannot compete with it.

A Member—Take it in.

Mr. King—I think the answer to that question must be governed largely by local circumstances. At Jacksonville (Ills.) we found that the best way to wrestle with it was to take hold of it ourselves, and we are now satisfied that we did the right thing.

Mr. Jenkins—This is one of the very questions that prompted me to visit St. Louis this year. At Columbus, Ga., we deem it a most important matter, and I wish Mr. King would tell those of us who are in doubt about the policy to be pursued how he accomplished success.

Mr. King—In the belief, then, that the Association wishes it, I will give our experience in regard to this matter; but my willingness to speak on the topic may perhaps be open to the charge of being tinged with selfishness, for I can in this way answer scores of letters that I have received. My correspondents have asked so many different questions that to frame separate and proper answers to their queries not only involve much writing but considerable study as well. The chief query from those on the seeming anxious seat has been in respect to the cost of electric light supply, and while I have prepared no paper on the subject, nevertheless, just before leaving home, I took some figures from our books which I will be glad to give. As I said before I believe this question of electric lighting must be decided according to local circumstances, consequently I cannot on this topic decide for another man, nor the latter for me. In our case a separate electric light company that started in Jacksonville made a failure of the attempt, for its proprietors did not receive the support or encouragement they expected to obtain. When they gave up the attempt we bought from them such portions of their plant as we could utilize in the system which we proposed to operate—the Thomson-Houston. Our present plant has a capacity for 63 lights, 25 of which are each rated to give 2,000-candle power, the remaining 38 being of the so-called 1,200-candle power type. In the first year we only supplied the 25 high candle power lights, but on July 1, 1886, we added the other 38 or low candle power variety. We supply the city with 31 lights, which are placed on towers, and are employed in lieu of the oil lights which formerly lighted what was known as the gasoline district. One of these towers, however, is in the center of one of the city squares, and so displaces more or less of the gas lights hitherto burned in that section. Because of the action of the Council we lost one-half of our gas lamps, not for the reason that they were not necessary, but because, during this year, and perhaps for several years to come, our city will be financially short, and shall not have the money to pay for all the lights that are requisite to meet the public lighting needs. Six of the 1,200-candle power lights are used on a tower in the park in the center of the square; the 2,000-candle power lights are located on towers on the outskirts of the city, and the balance of the 1,200-candle power lights are used in the stores of our merchants. We have never been called upon to change one of them—never had one of them given up, and have had very little complaint from them. For the commercial lights on a circuit that we operate until midnight we receive \$8 each per month, and for the public lights, which are also cut out at midnight, we receive \$100 each per year. In figuring on the cost of the electric light it is very much—and must be so—as it is with the gas business. For instance, Mr. Fullagar can make gas cheaper in Cincinnati than I can at Jacksonville, because the conditions are more favorable with him than with me. It is so in electric lighting. It depends most upon the way your power is generated, and upon the sort and consequent cost of the fuel employed, for I presume the cost of labor is pretty much the same everywhere. It is pretty hard to say where one uses (as I do) the refuse from the gas works for fuel, just what the cost of each light is from month to month. In running this plant I have a boiler 14 feet in length and 5 feet in diameter, with

78 three-inch tubes, set in the ordinary way. I also have a Parsons' blower, which answers my purpose very well. For fuel we use the breeze and screenings resulting from the operation of crushing the coke, and we also screen out the cinders from the retort furnaces. Sometimes we purchase a poor grade of slack that costs about \$15 a carload on the track. During the winter time all the extra fuel that I have to buy is one carload per month of this slack. At least that has been the average in the past winter. In the summer time one carload will last me for two months. In the matter of labor, I require two men, an engineer and a trimmer. They take entire charge of the plant. The trimmer collects the bills, keeps the books, in fact takes entire charge of that end of the business, and reports to me every month. So far I have no trouble to collect bills for electric lighting. Indeed I can say that these accounts are paid willingly and promptly. I have no "dead ducks" at all on the list. Now, as to the general results. We have been running for 11 months under the conditions stated, and having properly charged all actual expenses against the electric light department of our business, or so that everything which we ordered has been paid for, with a plentiful stock of carbons, oil, and other incidentals on hand, up to the first of this month, the profit figures out at \$2,549.71. The plant cost us \$17,346.20. In using the words "all actual expenses," I do not wish to be understood as saying that I have charged anything for rent, value of coke breeze used, superintendence, or for anything of that kind. The electric branch simply shows a profit of that much, under the circumstances named for the 11 months. These are the facts. The charge for superintendence is something which you must adjust for yourselves, for I never found two men who thought just alike as to what should be charged on account of that item. Now, with regard to the effect or influence of the electric light on our sales of gas. Since we have commenced to supply electric light our sales of gas have been larger than ever before. We have increased our gas sales seven per cent. during the last year, although we can account in a measure for a part of it. Having lost one-half of our lamp posts our sendout was diminished in that respect; but, on the other hand, an addition made to one of the State buildings devoted to public purposes more than compensated for our loss on public lamps, although the increase did not explain or account for all the seven per cent. increase mentioned. Our principal hotel keeper uses four arc lights—one each, on the outside, in the office, in the billiard and dining rooms. He pays a total of \$25 per month for these four lights, and his gas bill for the last year was 50 per cent. larger than it ever had been before. He overhauled and improved the hotel considerably, and I think probably put in new fixtures and burners, which improvements may account for much of the increase in the quantity of the gas burned by him.

Mr. Howard—Were you to put in eight electric lights perhaps his consumption of gas would be still larger.

Mr. Page—What do you charge for gas?

Mr. King—Two dollars per thousand.

Mr. Cosgrove—What system of electric lighting do you use?

Mr. King—The Thomson-Houston. These are facts in connection with my experience in electric lighting. I do not pretend to say they will apply in all cases, or that it is advisable for all gas men to put in electric light plants. Our directors, however, are quite satisfied with the Jacksonville showing.

Mr. Lansden—Others had been in the electric lighting business in your city before the Gas Company took hold of it?

Mr. King—Yes; but they failed in their attempt.

Mr. Lansden—Then the people were accustomed to the use of the electric light before you took hold of it?

Mr. King—Yes.

Mr. Lansden—Did you allow anything for wear and tear of machinery?

Mr. King—No; we keep that up out of the receipts. The apparatus now is apparently in as good condition as when we put it in.

Mr. Page—I would like to state it is admitted by electric light people that the wear and tear of their apparatus ranges from 15 to 20 per cent., therefore if that percentage is added to the \$17,000 some of the profit will pass away.

Mr. King—I think it is a question whether the wear and tear account will go as high as that stated by Mr. Page. So far as we are concerned whether we have made a dollar out of the electric light or not, we are satisfied with the result, because we control the field. I do not care who comes there now, for we not only have the inside track of the entire lighting business, but the new policy instead of diminishing our sales of gas has actually increased our sendout. We are satisfied that we did the right thing in putting in the electric light, even if, at the end of 10 or 15 years, it has been shown that we did not make a dollar out of it, for at any rate we will have at least paid for the plant out of its earnings. A

brother gas engineer in writing to me, some time ago, said, "We have an electric lighting plant here. Already some of the consumers are disgusted with it, and wish to come back to gas, but they have signed a contract, which binds them for a year, and I cannot get hold of that contract to see what it is like. I take it for granted that the printed forms of electric lighting contracts of the sort noted are pretty much the same, and if you have an extra form of contract to spare I wish you would send me one." I wrote in reply that contracts were something we did not pay any attention to—if a man said he wanted the light we put it in—because if he did not care to take the electric light we supplied him with gas; again, if he did not care to take the gas, he had to come to us for the electric light. In acknowledging my reply the inquirer answered that probably if the conditions were different we would think more of a contract, which is, perhaps, true. That is one instance of many which I might cite.

Mr. Watts—You said you got \$100 for each arc supplied to the city.

Mr. King—Yes; we get the same price for the 1,200-candle power lights that we do for the 2,000.

Mr. Harbison—On how many nights per month are they burned?

Mr. King—About 17 nights per month, and until 12 o'clock, only.

Mr. Seofield—Do the gas lamps burn later than 12 o'clock?

Mr. King—No.

Mr. Jenkins—The question was raised as to charging for superintendence and breeze. I understand you have not charged for either because there was no additional expense incurred by the Gas Company under these heads.

Mr. King—No charge was made for these items simply because the breeze that is now consumed was formerly thrown away, and no extra expense has been caused for superintendence.

Mr. Boardman—What was the feeling in the community when they discovered that the "bloated gas monopolists" had secured control of the electric light plant?

Mr. King—There was no trouble about it at all. In fact we were congratulated on having taken hold of it, because the people felt that it would be run as it should be, and they had been dissatisfied with the way in which the originators performed the work. We lowered the price per light at once. The former company charged \$12 per month for each light, whereas we promised to supply them at \$8. This step caused great satisfaction to our residents.

Mr. Watts—Do you think you are making anything on your commercial lights?

Mr. King—I have not figured it out; it is a matter that I have not gone into in great detail. I intended to go into a very careful test, and had arranged to have cards prepared every month showing the amount of power used, the number of carbons burned, etc., in order to be able to state everything exactly; but circumstances have been such that I could not do it. Eventually I will carry out that idea, and then I can tell just what can be relatively done with 1,200 and 2,000-candle power lights. Of course, any experiment of this nature, to be satisfactory, would involve a good deal of expense. Our directors having been satisfied with the showing for the year, which showing is so far ahead of what we had expected, accounts somewhat for my delay in instituting the more minute experiments which I would like to make.

Mr. Harbison—What is the difference that the city now pays for the electric light as compared with the gas lights that the former displaced?

Mr. King—The city now pays \$2,500 less per annum than was the case before. We are furnishing the city with all the light used. It is as well lighted as it was before, and pays nearly \$2,500 less for the service rendered. The gasoline was furnished by the city itself. You will remember that some of these electric lights are in the district formerly lighted by gasoline.

Mr. Harbison—What difference is there in the cost to the city for the electric lights, as compared with the gas lights displaced in that portion of the city lighted, leaving the gasoline district out of the question? Is the city paying more or less for light in those districts where you formerly supplied gas?

Mr. King—The lighting of the whole city is accomplished at \$2,500 less than any yearly sum ever paid before. They have not had the money with which to contract for all the lights they want, or that we would like to give them; and consequently only those portions of the city in which public lighting is an absolute necessity are at present illuminated.

Mr. McMillin—I would like to ask Mr. King if his conscience was perfectly easy about the price his Company was charging the city for gas before the electric light was tried.

Mr. King—\$17.50 per post is all that we have had for the last 6 or 8 years.

Mr. Harbison—The number of nights in the month that the lights are

burning is comparatively few when compared with the practice followed in other cities.

Mr. King—If you take the Philadelphia standard you will not find such a very great difference in the hours.

Mr. Watts—How many gas lamps have been displaced by one electric lamp?

Mr. King—That would be pretty hard to tell, because the electric lights chiefly displaced gasoline posts. In fact, the only one intended to displace any gas posts was the tower in the center of the square.

Mr. Averill—How many did that displace?

Mr. King—I do not remember exactly, but more than I wish it had, and more than we expected it would. A great difference of opinion exists about the value of tower lighting, and my mind is not fully made up on the subject. In some places tower lighting is unquestionably the best, while in other places pole lighting is superior. Perhaps we have accomplished with the tower what we could not have done with three or four times as many pole lights. The electrician who located our lights (he had performed a similar duty in many other cities) could not devise any better plan that would come within our means for lighting our city. Jacksonville's surface is flat, is very greatly scattered, and possesses a great many trees—in many places the trees form an arch over the street. It would be impossible to light some parts of the city at all because of the trees.

Mr. Jenkins—In our place we have a great many shade trees, and I do not think we could light up with the electric light unless we put a light at the corner of each block. We put only two lamp posts to a block in the thickest part of the city. How many lamp posts would that one electric lamp displace in the district where you use gas?

Mr. King—I cannot answer that question now.

Mr. Jenkins—According to your figures you can displace seven gas posts.

Mr. King—It depends upon how many gas posts you have in a given radius. You have two lamps in every 700 feet, while in Quincy, Ill., the gas posts are only 120 feet apart. It is hard to tell, unless the conditions are similar, just how many gas lamps an electric light will displace. In our place the gas posts are pretty far apart.

Mr. Jenkins—Do you think one arc would displace more than three or four gas posts?

Mr. King—It depends so much upon the shade and the buildings that I cannot answer you.

Mr. Harbison—I think Mr. King could answer that question very satisfactorily if he would state what, in his opinion, is the distance from one electric light pole that the light will radiate; whether he thinks it would radiate more than 150 feet in either direction. That would give the information desired on this subject. Whether or not, on this 700-ft. block, he thinks it would not be necessary to put one post at each end, and one in the center, in order to properly light the street. I think he will say "yes" to that question, if he answers as he believes it; but I do not want to answer the question for him.

Mr. King—Those who have paid attention to the matter know atmospheric conditions have a great deal to do with lighting availability of the electric light. Even when lights are so far apart that you may say you do not really see any effect from them, if they go out you will note a very great difference in the general appearance. Under the latter condition you cannot see nearly as far as you could when the lights (even though they appeared to be valueless as illuminators) were in duty. My residence is not quite half a mile from an electric light tower, but on almost any fine night I can step outside my door and read the time from my watch. On a foggy night I might not do it. The tower in the square carries five arcs, and although a gas lamp, burning four feet of gas per hour, is located right at the corner of my yard, on some nights I can get a shadow from the electric light toward the lamp post.

Mr. Harbison—In the one case you may look for a 10,000-candle power light, while in the other the light will not exceed 16 or 17 candles.

Mr. King—But one is nearly half a mile away. On cloudy nights I have noticed, from the reflection, that they light our town up immensely. A man came to me the other night and said he thought the whole town was on fire—a thunder storm was coming on and the clouds reflected the light. He is three-quarters of a mile from the tower, but could not make up his mind what was the matter, for everything was illuminated. That night the tower shone out beautifully, and nobody could ask for a better illumination. With regard to the satisfaction given by the towers, I can say that, on the whole, the people are better pleased with the light coming from the elevated arcs than they ever were by the lighting system formerly followed in the same districts. Of course some object to the towers. A man whose house cuts off the light from a tower so that the rays do not reach his front yard will complain. We have had some

complaint in that respect, but I think our people will bear me out in saying they have never before made so little complaint about the lighting as that offered this last year. They are also paying \$2,500 per annum less for the service.

Mr. Murdock—If I understand, you have five towers there.

Mr. King—Six altogether—five of 2,000 and one of 1,200-candle power.

Mr. Scofield—What is the difference between the 1,200 and the 2,000 candle power light? Is there a real difference of 800 candles in the lights?

Mr. King—Probably you know as much or more about that than I do, for I have never been able to make the test.

Mr. Boardman—What do you get for your commercial lights?

Mr. King—We get \$8 per month for a single light; those who use two lights get them for \$15; those who take four get them for \$25.

Mr. Boardman—Have you had occasion to place one of your 1,200-candle power lights in a position where one of 2,000-candle power had been used? If so, was there any difference noticed?

Mr. King—We have done that. At first we ran our 2,000-candle power light dynamo right on to the commercial circuit. When we put in the 1,200-candle power light probably four or five noticed the change by remarking they did not get quite so bright a light. They made no serious objection, however. I have often heard it said one could not detect the difference in the lights, and I believe that to be so. I think I could show you, in several instances, one light and then the other, and that if you had not seen them close together you could not tell the difference. I have replaced a high-power Siemens burner with an arc light, and the party who ordered the substitution was greatly pleased with the result.

Mr. Diall—How many dynamos have you used, and how long have you had them?

Mr. King—One has been running for two years, and it is working today as well as when put in. There is no noticeable wear, tear, or depreciation about it.

Mr. Howard—How high are the towers?

Mr. King—125 feet.

Mr. Graeff—Was the displacement of that Siemens lamp approved by the party simply because it was a matter of convenience? What opinion did he express with regard to the light?

Mr. King—In that case (it was a 50-ft. Siemens) the arc light was cheaper.

Mr. Graeff—I asked the question because I have tried, on more than one occasion, the experiment of placing a large Siemens burner (rated to a duty of 2,000 candles) in comparison with a 2,000 candle power arc light, and found that the Siemens would throw a shadow pretty close up to that of the arc. During the last year they have taken all the electric arcs out of our public squares in Philadelphia, Pa., and replaced them with Siemens burners.

Mr. King—The chief objection that my customer had to the Siemens burner was the care and responsibility of feeling that he had to look after it in order to save gas. He felt that if he did not look after it closely he would have to pay a very large gas bill at the end of the month, and was willing to pay something for the sake of being relieved from that anxiety.

Mr. Harbison—If you agreed to furnish him gas to that burner at so much per year, or as you did with the arc light, the "anxiety objection" would have been removed.

Mr. King—It would have been very different then.

Mr. Harbison—Then he would not have made the change?

Mr. King—He might not.

Mr. Cosgrove—At \$1 per thousand, how long would you keep the electric light plant running?

Mr. King—Even under that condition of gas prices I think we would run the electric light there just as we are now doing.

Mr. Scofield—Mr. King is, no doubt, a very popular man in his town. Indeed, I am satisfied of it from reports I have had from those who have visited him. I know that he is also on the right side of his City Council. The fact is that he handles the thing about in his own way. He has a good thing in it, but he has yet to make a showing here of the true profit involved in running an electric lighting plant. The question with us is this: Whether the gas fraternity should adopt the electric light, not for the dollars and cents that can be made out of it, but for the protection of their other interests.

The President—I think Mr. King answered that question very fully at the beginning.

Mr. Scofield—I am not satisfied with his answer. If he had an independent plant, and was obliged to erect buildings, etc., for its housing, and to charge for superintendence, I fail to see where his profit was to

come from. However, I will not stop to discuss that part of it. The question to my mind is whether it is practicable, and whether it would be advisable, for gas companies to adopt the electric light and run it in connection with gas, for the sake of protecting their gas interests. I have ignored this electric light business entirely. Of course they visited Fort Scott, Kans., as they did other little towns, and tried the same tactics with me as they did with others. Having boasted pretty loudly to our City Council, they finally succeeded in wresting the public lighting from me; but what looked at first like disaster finally proved a big benefit to me. When they got that contract we furnished 56 street lamps to the city, for which we got \$18 per annum each, the lights being extinguished at midnight. They agreed to light the place, for a certain sum, for one year. After the system had been in operation a short time the people became dissatisfied with the plan, and the discontent steadily increased. I beheld the leaven working, and pretty soon the electricians thought they read "the handwriting on the wall," and they were not mistaken. At the end of the first year, despite the 15 miles of electric light wire spread through the city, the City Council—the Councilmen who originally helped the electricians were the first to throw the latter overboard—said, "We have had enough of the electric light;" and the people echoed that assertion. The Council then asked for bids for public lighting for the ensuing year, and this invitation was accepted by five bidders—three on behalf of the electric light, one with natural gas, and one with artificial gas. I thought it was time to "climb on top," if possible, so I put in a bid to light the streets with gas for three years, and was awarded the contract. The electric light was thrown out. No electric light is now seen on our streets, simply because the people were not satisfied with it. Now, although I light at a low price, instead of lighting 56 lamps, as was the case before, the Councilmen have already located 220, and they will get the number up to 300 before they get through. So you see that I am "on top." I have defeated the electricians, and their advent has been a benefit to me. The question with me is whether it was better for me to run the electric light, or let somebody else run it, and after the people had had enough of it have the Council give me 300 gas posts instead of 50. I am to light those gas lamps all night, in the dark phases of the moon, at \$18 per year. There is not much money in it, but as I can make the gas without increasing my plant, why, there is no great loss in it either. In order, however, to get the increased number of lights I made a proposition to the city, saying I would extend my mains all over the district wherever they would locate one or two lamps on a block—our blocks are 333 feet one way by 270 feet the other—so they located (instead of two lights on a 700-foot block, as before) two on a block 333 feet long, following that scale pretty much over the entire city. Even in the hour of victory, however, I am inclined to seriously consider the question whether or not it would be better for us to take in the electric light and, where necessary, natural gas, and combine them under our own direction. I have opposed that idea right along, but am now disposed to go over to the ranks of those who think the other way, although I am not satisfied that our friend King will get very rich running the electric light at the price he mentions. The question is whether it is better for us to do this, or to go on and keep up an eternal fighting competition with the electric light and other interests. I have been about converted, and have about made up my mind that the best thing to do is to merge these conflicting interests. Even if we do not make a dollar out of electric light or natural gas supply, we will at least control the entire lighting situation.

Mr. King—I believe I started by saying this was a thing that must be handled locally, or according to prevailing conditions, further premising that in our case we were satisfied we had done the right thing. From the showing of the year it seems that others so far may have also done the right thing. I understand that my friend Littleton, at Quincy, Ills., is not to-day selling any gas to the city, while on the north of us, at Bloomington, the Gas Company has also lost the city lighting, which is being done by the electricians. In fact a similar condition prevails all over my immediate vicinity, except at Springfield. The gas companies are losing their grip on public lighting. Our object was to control the city lighting, whether we made a dollar out of the electric light or not. If we held our gas lights we were doing well. That is the way we look at it from our local standpoint. We do not care now if electric light is a failure for lighting a certain part of the city, for we can still light that with gas, and can also give them whichever light they want. Again, we have not had the fate, as to lighting the city, that otherwise we probably would have met were we not in control of the gas and electric supply. Wishing to retain the city lighting, we do not care whether the result of 10 years proves that we have not made, in the way of profit, a single dollar on our electric lighting business, for we shall believe that it has helped us in our gas business—provided, of course, that our sales

of electric light have enabled us to pay simple interest on the cost, and to keep in order the plant that we operate. I am glad to hear that Mr. Scofield is likely to become a convert, because I believe that, under the circumstances in which he is placed, he will still find it is the best thing for the owner of a gas company to do. I do not believe that the electric light is a very profitable thing for an outside company to attempt to supply—I am not arguing on that question at all, but simply speak from my standpoint as a gas man who proposes to use up what was a waste material in firing boilers to run dynamos. In the first year that we have run our electric plant to its capacity the operation has been satisfactory; and if we can so report in regard to a business which was entirely new to us, I believe the second year's work will be performed still cheaper and better. We are making gas more cheaply to-day than we did ten years ago, and I think I can learn much about running an electric light plant economically that I do not now know, and consequently expect to make this year's showing superior to that of last year. As to the point of not charging for superintendence, so many people look at that matter in different lights that I leave it to you to do just as you think best. As to the actual figures for running the plant and keeping up all repairs, on a plant of the capacity stated, we have expended \$1,935.80.

Mr. Howard—When did you reduce the price of gas?

Mr. King—A year or two before we took up the electric light.

Mr. Howard—Have you any Lungren burners in your city?

Mr. King—I have one that I use myself, and two or three have been placed in the public institutions before spoken of by me. Our merchants as a rule close their shops at 6 o'clock, and so we have no outlet for these burners in that direction. The electric lights are chiefly used in the saloons.

Mr. Jenkins—Will Mr. Scofield say what was the price of public lighting before and after the arc street lamps were introduced in Fort Scott?

Mr. Scofield—We received \$17.50 per post for half the night, and now get \$18 for all night. We are furnishing ordinary consumers at \$2.50 per thousand; large consumers, such as railroad companies, hotels, etc., are supplied at \$2.

Mr. Page—It is a remarkable fact that the electric light in England, where it was first introduced in a large way, has been almost an utter failure. In fact some of our American cities, having between 30 or 40 thousand inhabitants, can show a greater number of electric lights than can be found in the great city of London to-day. Naturally, the question at once arises, why is this so? Friend King has explained that there is no money in the electric light in competition with—what? With gas at from 60 cents to \$1 per thousand? No; but that there is no money in electric lighting with gas at \$1.25, or even at \$1.50. That is, no money for the electric lighting company. But there is money, without any question, for the gas company in running the electric light. I am satisfied that a majority of the companies in the United States will be running electric lights within the next three years. They must absorb it; it cannot be otherwise. Every electric light company now organized wants to sell out to the gas company. The electrical people are anxious to make the trade, but you do not want to buy out everything from these promoters. You want to buy your dynamos where you can buy them cheapest. You can buy wire from the Washburn & Moen Company cheaper than the electric companies can; and why? because, for one reason, your credit is better. You can plant the poles more cheaply, because you are used to such work. Another thing I can say to the gas men that is worth hearing. The carbons are an important item of expense in electric lighting; you will all admit that. When they were 12 cents per thousand they were an expensive item enough, but the carbon manufacturers, having pooled their issues, have raised the price to 35 cents. Now, the manufacture of carbons can be carried on on the premises of any gas company. A large portion of the material (retort carbon) is ready to your hands, and the retort will, when the carbon material is ground and mixed, give you plenty of baking space. Possibly one of the best things that can be done at this convention would be to appoint a committee to look into the cost of manufacturing carbons, and report upon the advisability of making these yourselves.

Mr. Boardman—I think we ought to look at this question on both sides, and having heard something of the rosy portion, let us look on the dark side. In Macon, Ga., we had almost come to the conclusion to buy out the electric light plant. They had a five-year contract with the city, which contained only one little flaw, at least that we could discover. We agreed upon the price, but when we found they could not give us proper deeds to it (owing to some slight hitch) the bargain was declared off. Soon after I heard that the Council were merely waiting for us to get control of this plant by purchase, when they (the Council) proposed to declare the contract forfeited because certain stipulations had not been

complied with. The owners of a gas company who go into this business will have to look out for trouble ahead; and while I believe it is a matter that should be thoroughly examined, I nevertheless think we ought to be in possession of stronger facts than those at present urged as reasons why we should embark in the business of a dual lighting supply.

The discussion was declared closed, and the Association ordered an adjournment, to terminate at 10 A.M. of the following day.

SECOND DAY—MORNING SESSION.

Routine business marked the introduction of the sessions for the second day. The Finance Committee of Board of Directors reported that they had examined the books, vouchers, and accounts of the Secretary and Treasurer, and decided that these were correct in all particulars. The report was filed.

REPORT OF SPECIAL COMMITTEE ON THE PROPOSED FORMATION OF AN AMERICAN GAS INSTITUTE.

The Special Committee appointed to consider the above-named proposition presented the following report:

We, the Committee appointed to consider what action should be taken with regard to the suggestions contained in the paper read by Mr. Frederic Egner, herewith report that, while there can be no doubt that the objects designed to be accomplished by the proposed American Gas Institute would result beneficially both to gas manufacturers and gas consumers, yet, from past experiences there *does* exist a great doubt if a sufficient number of gas companies can be induced to enter into an arrangement or agreement to supply the pecuniary aid necessary to carry the purposes in view into effect. We would, however, recommend that a Committee, to be known as the Committee on the American Gas Institute, be appointed, who shall issue a circular letter, under the heading and seal of the Western Gas Association, to all the gas companies of the United States, calling the attention of such companies to the paper mentioned, which will be published, in the regular transactions of this Association, by its official organ. Also, to inclose in said letters a series of questions bearing on the subject, such as the Committee may deem of importance, and to clearly express the action that each and every company addressed will take in the matter—whether they will agree to enter the defensive federation, or the Gas Institute portion of the scheme, for the investigation and promulgation of useful knowledge, only; how much, and for how long, they will contribute to its support; and whatever else they may be pleased to communicate. When the replies have been received, the proper Committee shall report, in writing, to the President and Board of Directors of the Western Gas Association as to what conclusions they have arrived at, and submit the facts as ascertained by them. Then, should these data be favorable to the establishment of the American Gas Institute, an extra session of the Western Association shall be called, or else a meeting of the Board of Directors shall be convened, who shall thereupon devise further steps to satisfactorily accomplish the desired end.

Or, in lieu of all this, the Committee on the American Gas Institute shall be empowered to take all necessary steps to accomplish the work, and report at the next annual meeting of this Association.

E. McMILLIN,
FREDERIC EGNER, } Committee.
HENRY PRATT,

MR. WATTS OFFERS A RESOLUTION.

When the report had been read the Secretary announced that Mr. Sylvester Watts wished to submit the following resolution, which proposed to accomplish the end in view by means somewhat unlike those urged by the Special Committee. The Watts resolution is appended:

Resolved, That a Committee of five, to be known as the Committee on Establishing an American Gas Institute, and to be composed of the President, First Vice-President, Secretary, and two members of the Western Gas Association, shall be designated and clothed with full powers to act as they may deem advisable, and find possible, in the premises as set forth in the paper read by Mr. Frederic Egner at the Tenth Annual Meeting of the Western Gas Association. The progress made in the work of the Committee to be reported from time to time in the official organ of the Association, and such other journals as may be deemed advantageous aids in spreading such information, and to be instructed to report in full at the next regular meeting of the Western Gas Association. Furthermore, that Secretary Littleton be asked to invite the other Gas Associations of America to take action, and co-operate with this Association in the matter of establishing an American Gas Institute.

The report and resolutions were then subjected to the following discussion:

The President—What is your pleasure with regard to the resolution offered by Mr. Watts? That differs from the report of the Special Committee only in the matter of the number and personnel of the membership of the permanent Committee.

Mr. Pratt—If either the report or resolution is now adopted, are we to understand that such action will terminate or shut off all debate?

The President—Not necessarily.

Mr. McMillin—It seems to me you seek to exact too much work from your officers. We have a membership of something like 200 in this Association, and I think the work of carrying on its affairs should be more widely distributed than it is. Having signed the report of the Committee I must, of course, indorse the sentiments of the Watts' resolution, but I will dissent from the recommendation in regard to naming the Committee. I think that its proposition, to say the least, is hardly judicious, especially so far as the Secretary is concerned. Instead of placing too much work on his shoulders, let us distribute the labor among the members of the Association as much as possible. As a rule, you elect the active members of your Association to hold office—men who, having a great deal of work to do, have but little spare time. Yesterday we put on them the additional duty of selecting those who are henceforth to read papers, and the further task of naming the subjects upon which the papers are to be prepared was assigned them. Now, that means no small addition to their labors. I myself would very much prefer that this Committee be taken from among the members of the Association who are not officers.

Mr. Watts—I do not think the officers will have much to complain about in regard to the extra work involved in serving on this Institute Committee, because most of the work would be done by Mr. Egner, as the promoter of this scheme. I think it would be well for the officers of the Association to be on the Committee, and to consider the subject fully, so that whatever is done can be done in connection with the Association.

The President—The vote will first be taken on the Watts' resolution. [The question was then put on the resolution, and it was declared lost.]

The President—The question now comes up on the adoption of the original report of the Committee.

Mr. Egner—The original report does not appoint a Committee to do the work. It merely recommends that a Committee be appointed.

Mr. Jenkins—There are two recommendations in the report. Which are you going to adopt? Do not let us adopt both of them. I move the adoption of the first recommendation—that is, the appointment of a Committee with power to get up statistics and instructions to report back.

The President—The question will come before you, then, on the first proposition.

Mr. Jenkins—Let the first proposition be read again, so that we can understand it.

[The report of the Committee was again read by the Secretary.]

The President—You have now heard both propositions read. What is your pleasure?

Mr. Pratt—I am not in favor of the report as a whole, for, although it is indorsed by the Special Committee, the understanding was that the Association would determine which proposition was to be accepted. I do not believe in the extra session proposition, for that will involve a larger and, to my mind at least, unnecessary expense.

The President—But the report leaves that at the option of the Committee.

Mr. Pratt—I should object to calling a special meeting for any such purpose. In the first place, I do not believe that an Institute of the sort suggested can be formed to comprehend or inclose all matters contained in that paper, for the simple reason that gas companies control their own business. We might possibly induce a few to go into such a thing, but most of the active members here are either gas engineers or superintendents, and are not stock owners or directors of companies. We might invite them to act, but further than that we have nothing to do with it. As soon as this committee or association is formed and in working order its decisions would become public property, therefore a gas company not a member of the Institute would be benefited as greatly as those which were members. While I would like to see it go into effect, I fear it is impracticable. Each engineer has to determine for his own company what is or is not suitable for its best interests.

The President—I do not want to stop debate on this subject, but I would remind you that we have considerable to do. Yesterday we went over all this matter thoroughly, and the Committee then appointed has handed in a report.

Mr. Howard—The report makes no allusion to or provision for the payment of any expenses that may be incurred.

The President—Adopt the report first, and then attend to the money provision.

Mr. Egner—The idea of the resolution offered by Mr. Watts was that somebody should start this thing, and that there was to be no preliminary expense about the matter. As Mr. Watts has said, I was willing to shoulder all the trouble and expense, only asking this Association to father the project. There should be some authority for what the Committee does. I am willing to have circulars printed and sent to the gas companies, and the answers received will be submitted to the Association. Some one must start this thing. If it is not started no progress will have been made, and the result will be that next year we will be further off from accomplishing anything than we are now.

The President—The question is on the adoption of the first proposition of the report of the Committee. The first proposition provides for the calling of an extra meeting of the Association, or a meeting of the Directors. The second proposition merely directs the Committee to report at the next meeting.

Mr. McMillin—The question as to those two plans ought to be discussed. I favor the second proposition, and, for that reason, will vote against the first one. It will turn this matter over to the Committee, with full power to act; and that power would include the power of negotiating with the Executive Committees of Associations other than our own. Of course, we cannot expect to run this as a Western Association matter. It must necessarily include all of the Associations. The power given to the Committee under the second plan would enable them to attend the meetings of other Associations and obtain the views of the fraternity at large on the matter. In that event their report to us next year would afford a solid working basis.

The question was then put on the findings of the Special Committee. The first proposition was declared lost, and the second was adopted.

Mr. Howard—Now, I think the Committee ought to be furnished with some money; or the Association ought to say that any money expended by them would be repaid. I move that \$50 be appropriated for the use of the Committee. [Agreed to.]

The President—How many shall be appointed on that Committee?

Mr. McMillin—I move that a committee of three be appointed by the Chair, and that the gentlemen named be selected from those who reside in or near to St. Louis, in order that they may meet frequently and without unnecessary travel.

The motion was agreed to. The President appointed Messrs. Egner, Watts and King as the Committee.

Mr. B. E. Chollar, of Topeka, Kansas, now read his paper on—

THE RULE OF THE INVERSE SQUARES.

Of late years, and especially since the advent of the electric light, with its dazzling brilliancy and hardly less magnificent claims for "candle power and illumination," the testimony of the photometer has been invoked for the purpose of establishing, as facts, things so much at variance with the inferences of reason and common sense, that grave doubts have arisen, not only as to its accuracy as an instrument of precision, but also as to the truth of the so-called law upon which it is founded.

It was stated,* at the late meeting at Boston, Mass., that the investigation of this subject belongs more properly to the physical laboratory than to a gas convention; but while this remark is eminently true, the scientists are so very slow in coming to our relief that it may be, perhaps, not out of place for us in the meantime to agitate the matter among ourselves, and to do what little we can in our own way toward accounting for and explaining some of the apparent inconsistencies of our optical yard-stick.

There is an old French nursery rhyme which runs thus:

Quand nos trois poules vont aux champs,
La premiere va par devant,
La deuxieme suit la premiere,
La troisieme est la derniere.

Translated into English it tells us that when our three chickens go out into the field, the first one goes ahead, the second follows the first, and the third one is last.

Writers on gas and gas lighting seem to have followed pretty nearly the same practice; for almost without exception they have prefaced the discussion of the subject of light measurement with the broad assertion that the practice of photometry is based upon the natural law that the light from a luminous body decreases in proportion to the square of the distance. The exact agreement in idea, taken in connection with a remarkable similarity of enunciation without attempt at proof, would seem

to justify the suspicion, at least, that a majority of the authors have followed the custom of the chickens, and have assumed as true what had been so laid down by their predecessors. Professor Tait, of Edinburgh, however, in his article on "Light," in the last edition of the *Encyclopedia Britannica*, states the law differently, and in such a way as to show very plainly that he, at least, is no chicken. He puts it thus:

"If the medium be transparent, the intensity of illumination which a luminous point can produce on a white surface directly exposed to it is inversely as the square of the distance."

An examination of the following diagram will show that the idea that the law of inverse squares is a natural law of light is a mistaken one, and that the real law in the case is neither more nor less than the geometrical principle that the surfaces of spheres are to each other as the squares of their diameters.

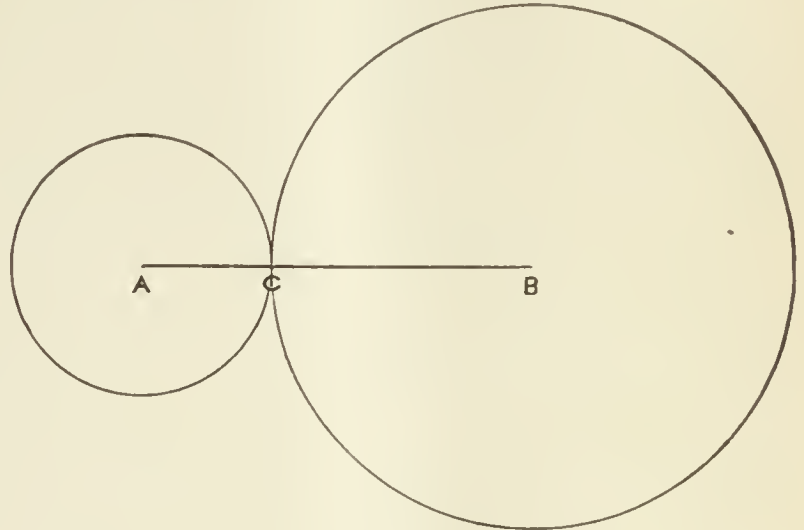

Let *A* and *B* represent two luminous points, and *C*, in a straight line between them, the point of equal illumination. The intensities of the two lights will be measured by the surfaces of the two spheres, *A* and *B*, which surfaces are to each other as the squares of the radii, *AC* and *BC*; but these two radii represent the distances of the lights, hence the intensities of the two lights are to each other inversely as the squares of their distances.

The following simple corollaries deduced from the above are almost self-evident:

1. Since a sphere can have only one center, and that center must be a point, it follows that the law, when applied to lights, can hold good only for luminous points.

2. Since only divergent straight lines can be drawn from a common point, the law can hold good only for divergent rays.

3. *A* and *B*, being assumed as points, are alike in size; but since the light from one is more intense than that from the other, it follows that the intensity of a light is independent of its size.

Let us now reverse the conditions and consider the relative values of lights of appreciable magnitude.

Let *AD* (see diagram, p. 8) represent a luminous line emitting divergent rays from every point. We may suppose a point, *E*, at which rays will converge from every point of *AD*. Now, since light moves in straight lines, all rays starting from *AD* in the direction of *E* must remain within the limits of the triangle, *AED*; section, *ee*, of *AED*, therefore, parallel with *AD*, will represent aggregates of light waves or quantities of light equal to each other and equal to the total quantity emitted by *AD*.

It appears, therefore, that, irrespective of intensity, the quantity of light from a luminous body at any particular point is independent of the distance of the body, and is in direct proportion to its diameter. If the above reasoning is correct, the total energy exerted by a light is represented by the product of two factors, one of which being increased the other can be correspondingly reduced.

The rule governing the value of lights, therefore, would be something like this:

The light from a luminous body is inversely as the square of its distance, and directly as its projected area.

This is strictly in accordance with the all-pervading law of mechanics, that the work done is a function of force and time. The power of an electric current is expressed by the product of a volt and the ampere. So, also, the value of a light should be measured by the product of its intensity and quantity. Electric lights, by reason of their small size and great intensity, are analogous to small currents of high electromotive force, while the larger and less intense gas lights correspond to larger currents of less potential. The "light of the future" adheres closely to the rule of inverse squares, and rapidly becomes thinner and

* See JOURNAL, March 2, 1887, p. 141.

thinner as the distance increases; while on the other hand the old, reliable gas light is more equable in its distribution, and sends a greater proportion to a longer distance.

In the interesting experiment described by Mr. Boardman,* although with the same consumption of gas the student lamp chimney produced a greater intensity of light, the practical test demonstrated that the product of size and intensity or total energy was greater with the Argand. So, also, with the experiment with opal globes mentioned by Mr. Prichard.† The use of the shades undoubtedly reduced the intensity of the light, but the great increase in size produced a large preponderance of convergent rays, which, according to the foregoing, were not governed by the law of inverse squares, but held their own to a greater distance, and lighted

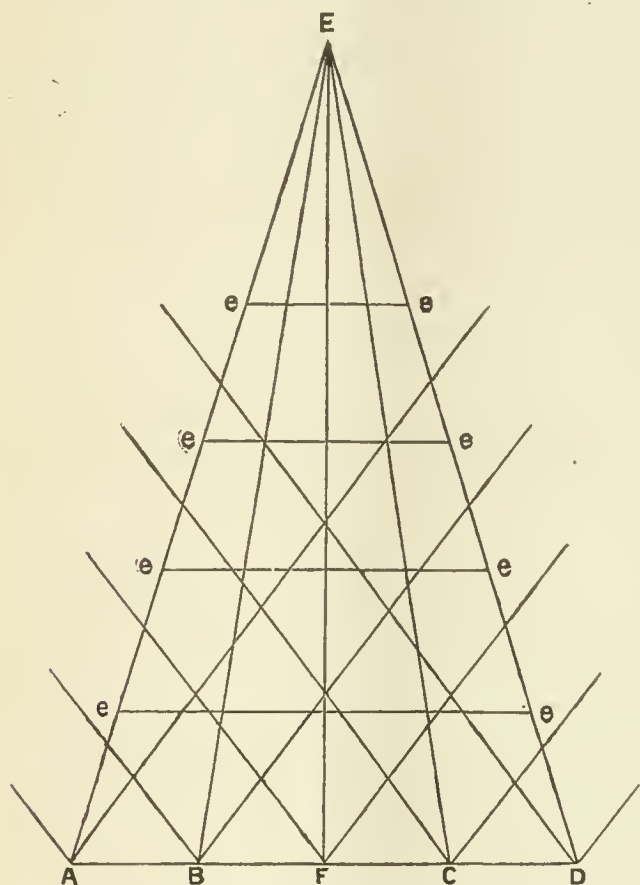

the room more uniformly, but a little less brilliantly than before. The following method, therefore, suggests itself as a means of getting photometric measurements approximating to accuracy. The intensity of the lights should be compared through small apertures as close to the lights as practicable. The ratio of the intensity thus obtained multiplied by the ratio of size ought to give the relative value of the two.

The unequal brilliancy of the colors of the spectrum is quite noticeable, and Fraunhofer found that if the greatest intensity, which is between the yellow and green, be represented by 1,000, the orange would be 640, the red 63, the green 480, the blue 170, the indigo 31, and the violet 6. Dr. Schilling, in his work on spectrum analysis, gives the following as the proportions which the various colors occupy in the spectrum: If the whole length be 100, the red would be represented by 12, orange 7, yellow 13, green 17, blue 17, indigo 11, violet 23. Combining these ratios of intensity and quantity, we find that the red, orange, yellow, and green occupy 49 per cent. of the length of the spectrum, and furnish 90 per cent. of its illuminating power, while the blue, indigo, and violet take up 51 per cent. of the length and give only 10 per cent. of the light.

Now it happens that gas lights are by far richer in the rays of the red end of the spectrum than are the electric, especially the arc lights. We have, therefore, a decided advantage, both in regard to size and quality—size giving reaching power, or what is probably meant by the term diffusiveness, while quality, or color, determines the proportion of useful rays.

What we want to do, therefore, in order to put our gas "where it will do the most good," is to obtain the largest and brightest flames in proportion to the quantity of gas used. In order to do this we must drop empiricism and go at the matter as thoroughly and systematically as the electricians do in their measurements. Scientific research is exerted more energetically as a power directly behind their business than ours. They need now and will continue to need every advantage that they will be able to obtain, and the very fact that, under the protection of patent

laws, dynamos and electric apparatus in general can be bought in open market without charge of royalty for subsequent use, is ample proof that the business of electric lighting can hardly be considered as even fairly profitable.

With industry and energy on our part there need be no fear for the future of gas lighting:

Fully nine-tenths of our gas, so far as lighting is concerned, will be consumed with the ordinary flat-flame burners. These, then, should receive the greater share of our attention; and it is safe to say that, by patience and perseverance, the flames of our ordinary burners can be enlarged and brightened up to such an extent as nearly to double the quantity of light now obtained in ordinary practice.

With regard to burners of high illuminating power, it is hardly possible to imagine a more complete arrangement than that of the Siemens-Lungren. The flame is both big and bright, and every bit of its surface is utilized. A flame is largely transparent to its own light. There ought to be, therefore, no opaque draft tubes or deflectors to shut off in any direction any part of the light actually developed. All these desirable conditions are to be found combined in the Siemens-Lungren lamp—hence its wonderful success.

If the ideas herein expressed are correct, we may reasonably expect that, with a fair test and fair count, the gigantic claims of the electricians can be scaled down, and the more moderate pretensions of the representatives of gas lighting enhanced to a degree that will enable the larger lamps of the Lungren type to compete successfully with the nominal 1,200 and 2,000-candle power electric lights.

(To be continued.)

Spectroscopical Test of Tar Colors.

"O. L.," in the June issue of the *Journal of the Franklin Institute*, notes that artificial and natural dye stuffs are tested with regard to shade and purity, as well as strength, by simple dyeing, which requires great practice and shows differences in strength of but 5 per cent. only with difficulty, whilst differences in shade often lead to errors in estimating the strength.

The investigations of H. W. Vogel, K. Vierordt, and G. Kruss have rendered it possible to determine, with rapidity and accuracy, the amount of coloring matter in a solution. The method is based on the following considerations: Every substance can absorb only those rays of light which have the same rate of vibration as its own molecules, producing, therefore, absorption bands in the spectrum of the light reflected by it. With the same light, the absorption band is the darker the greater the amount of the absorbing (colored) substance contained in the unit of space, and there is a simple relation between the absorption of the light and the quantity of coloring matter.

If $\frac{1}{2}$ of the rays of a beam of light pass through a 1 cm. stratum of color solution, a second similar stratum will allow only $\frac{1}{4}$ of this $\frac{1}{2}$ to pass through it, and so on. The same result is obtained if, instead of the light passing through two such strata of solution, it passes through one of double strength. Therefore, if the amount of light which passes through a 1 cm. stratum of a solution containing 1 mg. of color in 1 l. = a , then the amount of light passing through a solution of x times the concentration of the former is $b = ax$, where x indicates the number of mg. of coloring matter in 1 l. solution, or $\log b = x \log a$, or $x = \log b \div \log a$. The quantities a and b are easily and rapidly determined by the spectroscope. P. Schoop has adapted Kruss's apparatus for quantitative spectral analysis for practical purposes. The instrument consists of a tube with slit, prism, and telescope, which is so arranged that any position in the spectrum can be examined and determined.

The slit is divided in two halves; the upper is movable, the lower is fixed. Immediately in front of the lower slit is placed a vessel with parallel glass slides, 1 cm. apart, to hold the solution of dye stuff to be tested. By regulating the height of the solution in this vessel two spectra are obtained, one of the source of light, (a petroleum lamp), and the other the absorption spectrum of the solution. The darkest part of the latter is then found, and the movable slit regulated until the amount of light in each spectrum is equal. The extent of movement is shown on a drum attached to the micrometer screw, and serves as measure for the intensity of the light, that of the upper slit being the unit. The average of a number of readings, which can be made comfortably within a minute, is put down as the intensity of the light.

Having in this manner determined the intensity of light, for a normal solution of a dye stuff, a similar determination at the same position of the spectrum suffices to calculate at once the concentration of a solution to be tested with the aid of the above formula.

Dilution causes no change in the position of the maximal absorption,

* See JOURNAL, Jan. 3, 1887, p. 7.

† See JOURNAL, March 2, 1887, p. 139.

and the spectrum of a mixture of two color solutions is equal to the sum of the absorption spectra of the single solutions.

The apparatus can also be used to analyze commercial mixtures of two and more colors; also to determine the end of the reaction in the formation of coloring matter (rosaniline by arsenic acid, or nitro-benzol, methyl violet, bluemelts, etc.), also for standardizing colored salt solutions for analytical purposes (permanganate) and for color reactions.

SPECIAL ENGLISH CORRESPONDENCE.

COMMUNICATED BY NORTON H. HUMPHRYS.

SALISBURY, June 10, 1887.

The Forthcoming Meeting of the Gas Institute—Jubilee Rejoicings—The Electric Light and Plant Life—Gas for Cooking and Heating—At the Exhibitions.

The notices and particulars of the proceedings at the next meeting of the Gas Institute, to be held at Glasgow, on the 28th inst., and two following days, under the presidency of Mr. Wm. Foulis, M. Inst. C. E., have been issued to the members, and no doubt perused by them with some gratification. That is to say, by those who are able to count on being present. The absentees will be more numerous than usual this year, because the Council have been unfortunate in their choice of the date. The rules provide that the meeting shall be held on the second Tuesday in June, which falls on the 14th inst. But this year, on account of the Jubilee rejoicings, to be held on the 20th inst., throughout the country, in connection with which it is anticipated that large demands will be made on the "illuminating power" of coal gas, thus throwing an increased amount of labor and responsibility upon the managers of gas works, it has been thought that the general convenience would be assisted by postponing the meeting till after the Jubilee day. In so doing, however, the Council have only escaped Scylla in order to fall into Charybdis; for in selecting the last three days of the half year, just when the meter indices and the stocks have to be taken, they have chosen a date when the managers—of small works at any rate—are obliged to be at their posts and cannot be away, unless they are so fortunate as to have a reliable assistant who will keep things going properly during their absence. In large works of such magnitude as to require a responsible superintendent at the head of each department of course this objection does not apply; and possibly, as one of the sufferers, the writer is inclined to unduly magnify its importance.

The programme comprises eleven papers, and the principal feature of it is that several "master minds" are going to deal with topics to which it is known they have given special attention, and with which their names are intimately associated. Mr. Geo. Livesey is going to speak on "the Sliding Scale;" and the subject of "Gas Legislation" will receive attention from Mr. W. J. Warner. Dr. Stevenson Meadam is to treat on "Gas from Oil;" and Mr. D. R. Stewart, of Broxburn, will read a paper entitled "Some Notes on the Distillation of Shale for Oil Making, and the Manufacture of Sulphate of Ammonia." This paper claims especial interest, because a visit to the Broxburn oil works is a feature of the proceedings. Mr. John Head, manager to the firm of Siemens Bros., has something to say about the "Siemens Regenerative Furnace" which is used at the Glasgow gas works. And we must not forget to welcome the reappearance of the name of Mr. Geo. Anderson on the Institute programme. This gentleman has contributed many useful papers at past meetings, but latterly his name has not appeared so frequently, as, in the interests of the gas industry and of progress, it might do. After the meeting a day's recreation, as usual, is to be enjoyed, and this time it takes the very attractive form of a long steamboat excursion—down the Clyde, through the Kyles of Bute, and up Loch Fyne, amidst the lovely scenery for which Scotland is so justly celebrated. The genial and gallant editor of the *Journal of Gas Lighting*, at the behest of a correspondent, has made inquiries and is able to announce that the presence of ladies will be welcomed at the trip. This is as it should be, for it is difficult to conceive a more miserable looking herd than a party composed entirely of the male sex doomed to a long day on the water together. Only, why was it not put on the programme?

The preparations for the Jubilee rejoicings have now commenced in earnest. The British public, having remained in a quiescent state, with the exception of an occasional inquiry as to what their neighbors are going to do, and a grumble at the absurdity of festive rejoicings in general, and this one in particular, until nearly the last minute, as is their wont, have now roused up thoroughly, and decided that the thing must be carried through in thorough good style. Accordingly in every town the air is filled with the voices of Committeemen and of honorary collectors for subscriptions; whilst the respective merits of free dinners, torchlight

processions, triumphal arches and street decorations, treats to the school-children, illuminations and fireworks, are discussed at such length as to impede ordinary business operations. Most of the well-known gas fitting firms are applying their resources to the production of new designs in the way of gas illuminations. And the fact that the Jubilee day happens to come upon the longest day of the year, when the shades of darkness do not fall until after 9 p.m., does not appear to curtail the public desire for something brilliant after dark. So far as the interests of gas companies are concerned the short hours of darkness are just as well. For the illumination department, carrying with it an abnormal increase in the demand for gas, extending only over a night or so, is not a source of profit. In some parts, notably in the West End of London, it is rumored that gas illumination on a very large scale will be carried out. The question of supplying gas for illuminating purposes gratis has been debated in many districts, and especially in towns where the gas works belong to the local authority. But the plan does not find much favor. In the first place the Parliamentary restrictions imposed upon most gas undertakings are so stringent that it is doubtful whether they are able to "give away" gas for any purpose. In one town I notice that gas will be given, subject to the device that it is to supply being approved by a committee; and this is a very wise precaution, because if gas is to be had for nothing people rout up any old worn-out device that can be met with, or hurriedly construct something or other, in anything but a workman-like manner, that perhaps passes as much gas by leakage as it consumes in a legitimate way. There is also the fact that many of the business houses that are illuminated, especially inns and restaurants, make the thing more or less of an advertisement. But the chief objection to unlimited gas illuminations is that whilst the mains are laid with a due regard for increased consumption, festivals of this kind occur so rarely that no provision is made to meet them, and the supply pipes are therefore unequal to so large a strain in addition to their ordinary duty. I remember once that, on the occasion of a local rejoicing, a large number of gas illuminations were erected in all parts of a small town which was situated on the side of a hill. The carrying power of the main pipes was greatly overtaxed, with the result that the upper parts of the district fairly sucked the lower levels dry. The bulk of the gas was consumed at the higher altitudes, and in the low districts the illuminations would not keep alight, nor was the state of things any better in the houses.

It will be remembered that, when the modern electric light mania was commenced, one of the pretentious claims advanced for it was that its resemblance to sunlight was so far complete as to secure a share of that stimulating influence on plant life which is a special and beneficent characteristic of the orb of day. Reports of extraordinary "forcing" processes conducted by this medium were freely circulated. I remember inquiring at the time if the electric light would also "tan" ladies' complexions, and fade carpets and window hangings, to which no answer was forthcoming. The experience at the Winter Palace at St. Petersburg does not tend to advance claims of this nature, for its effects on the ornamental plants, especially the celebrated collection of palms, have been most disastrous. The complete illumination for only one night will, it is said, cause the leaves to become dry, yellow, and withered, and the injury is proportioned to the extent of the exposure. Plants situated in the full glare of the light suffer most, and those in niches or places protected from the direct rays of the light remain uninjured.

There is a very satisfactory amount of energy in the gas stove business. Exhibitions of gas appliances are evidently not yet spun out, although they have now been before the public for several years; for the serial literature of the last month or so comprises accounts of several very successful undertakings of this class. And in towns where exhibitions have previously been held lectures on cookery, illustrated by means of stoves, are found to be very successful as a means of retaining the public attention and interest in the uses of coal gas as a domestic agent. As an example of the extent to which gas is being introduced in our large towns, Glasgow may be mentioned. Mr. Foulis has arranged a gas burner suitable for fixing in the ovens of existing kitchen ranges, thus converting them into gas cookers. These are supplied on hire, as the ordinary gas stoves are supplied, and no less than 1,550 of them have been sent out. So far as may be judged by the official patent lists considerable activity prevails among inventors in the line of gas appliances. Among the novelties that have actually been put upon the market this season is a gas boiling stove that is automatically turned on and lighted through the medium of a flash jet by the simple act of placing a kettle or other vessel upon it, and the removing of the vessel secures the shutting off of the gas.

Speaking of exhibitions reminds me that several shows of this kind, partaking of a general technical character, in which gas has been well represented as one of the principal industries of the country, have recently

been held or are at present open. The Manchester Royal Exhibition may be instanced, in which, amongst a large variety of exhibits, may be seen a great many different sorts and sizes of gas engines, models of purifying and storage plant, engines and exhausters, coke breakers, retort lids and mouthpieces, models of sulphate of ammonia apparatus, etc. At the Yorkshire Fine Art and Industrial Exhibition gas and cognate industries were represented, and Mr. C. Sellars, Secretary and Manager to the York United Gas Company, gave an interesting lecture on "Gas and Some of Its Residuals," which consisted of a very able review of this fertile subject. There is also the industrial exhibition at Newcastle-on-Tyne, where one noticeable feature is a complete model showing a coal mine in full operation. Altogether, the public cannot complain that they have no opportunity of acquiring general knowledge on the subject of gas and gas manufacture; and it is to be hoped that they will avail themselves of the same, and so put an end to the absurd prejudices which still crop up occasionally respecting the operations of gas companies. Only yesterday an intelligent and well-educated person, having inquired if it was not true that a gas meter would measure air with as much facility as gas, and being answered in the affirmative, at once jumped to the conclusion that the gas company could force either gas or air through his meter, as they might wish, and that they did not fail to send a considerable quantity of the latter. I mention this curious prejudice because it has more than once come to my notice lately as being entertained by individuals who were fairly well acquainted with the *modus operandi* of testing meters and gas works operations in general. One of this sort recently proceeded to the testing inspector's office, with his meter under his arm, to avail himself of the right provided by law of seeing the meter tested in his presence. As the operation was commencing he inquired if the gas as supplied to the public was used for the test, and was told that the meter would be tested with air, as being more economical than gas. He at once repudiated further dealings with the inspector, regarding him as a tool of "those artful gas people;" and rushed into print without delay to expose what he considered to be roguery, at the same time taking some credit for the pertinacity which had led to the supposed discovery.

Notes from the West.

By RETORT.

JUNE 25, 1887.

Probably at no other time in our history has the exploring of Mother Earth been so active as in the present. The derrick is becoming as familiar to the eye of the railroad traveler as the water tank—especially in Ohio and Indiana. In the former State it is settling down to a systematic feature of business, while in the latter all the excitement incident to its newness is experienced. Indianapolis, after many failures, has at last met success on the Harris farm, which lies 17 miles north of the city, and which, after being "shot" yesterday, commenced business as a "gusher," yielding 350 pounds pressure, and, it is estimated, an output of 3½ millions cubic feet per day. Piping will begin at once, and the supply is to be led into the city. This is the most successful well discovered so far south.

The development of natural gas has proven an admirable educator of the public in the use of gaseous fuel, and, as a result, the gas stove trade has been unusually active this season in the territory supplied exclusively with artificial gas. There are two things that materially retard this very important branch of our industry, the principal one of which is the price at which stoves must be sold. Gas companies, as a rule, sell all these goods at cost, and very often at a loss, for the sake of the increase in consumption; but even then a four-hole stove costs, on an average, about \$25 to \$30, while a three-hole costs about \$20, put up ready for use. This very often defeats the sale, to a goodly number of consumers, for several seasons. What the public want (and the gas companies also) is a good gas stove that can be *placed ready for use* at prices about 40 per cent. cheaper than those now ruling—say, a three-hole stove, \$12 to \$15, and a four-hole at \$16 to \$20. There being a very large demand for just such a stove, it would meet with a ready sale.

The gas stove trade is in turn developing another feature in our industry, or rather an auxiliary—the cooking school. Those companies that have had the enterprise and good fortune to secure one of these schools have reaped a rich harvest (on account of all the money expended), for they have uniformly proven a wonderfully active advertiser of gas stoves, and thus led to many sales; but I find among the gas men an inability to obtain these teachers, the number being very limited as compared with the demand. Ohio and Iowa seem to lead in this department just now. Why would it not be a wise thing for the stove manufactur-

ers to secure a number of competent ladies trained for this work? It would greatly extend their own business, besides giving lucrative employment to a goodly number of worthy women.

The Equalizing (?) Boards are just now holding their annual sittings, and will, as usual, give the gas companies their annual whack. It seems to be an unwritten law in many parts of the West that the gas company shall have its assessment raised by these wise (?) gentlemen who have a keen appreciation of the value of every other class of property—save their own—and who universally brand the sworn statement of the gas company as a dishonest attempt to undervalue its property. The first instance this year that came under my eye was that of the Indianapolis (Ind.) Gas Company, the property valuation of which I see, from a local paper of recent date, was raised from \$414,076 to \$467,340. I know very little of the value of the property, but this practice is becoming so very common that it is a serious matter with those whose money is invested in gas stocks; and the custom places a premium upon dishonesty, inasmuch as regularity in raising will beget regularity in depreciating the return.

ITEMS OF INTEREST FROM VARIOUS LOCALITIES.

AN EXPLOSION AT RUTLAND, VT.—On the morning of Saturday, June 18, Rollin Clark, a clerk in the office of the Town Clerk of Rutland, opened the vault in order to hunt up some documents that he desired to examine. So as to expedite matters Clark ignited a match for the purpose of lighting the gas burner that illuminates the Rutland stronghold, and his action was attended with some astonishing results. An explosion accompanied the "striking of the match," and the inner door of the vault, torn violently from its hinges, sailed out to the main office, wherein it played havoc with the wainscoting, etc. The glass in the sashes of the main office was all destroyed, and the desks, fittings, etc., will require much attention at the hands of the furniture makers ere the Town Clerk can depend upon them as of yore. Clerk Clark, although pretty badly shaken up, did not receive any serious injuries, but it may be taken for granted that hereafter he will "smell for leaks" prior to "striking a match" in the receptacle devoted to the safe housing of Rutland's "pub. docs." The cause of the gas escape was traced to a defect in the service pipe that fed the vault burner.

A HINT OR TWO FROM NORFOLK, VA.—As before noted in the JOURNAL, Mr. T. A. Bates is now in the employ of the Norfolk Gas Light Company, his appointment as Superintendent to that Company having been made on April 1, of present year. On June 18 the directors decided to make a concession in gas rates, the same to take effect on 1st inst., and that action guarantees to the Norfolkites a satisfactory artificial illuminant at the net rate of \$1.60 per thousand cubic feet. In cases where the meters show a monthly consumption having a total money value of \$25 or upwards the net figure is placed at \$1.50 per thousand. The Norfolk Company is fitted out with dual apparatus, which enables it to make either coal or water gas, the water gas plant being a specimen of the Granger class. Both plants are constructed on modern lines, and President Allmand, who is a firm believer in the efficacy of liberal methods of working, stands ready to give the patrons of his Company the benefit of reduced gas rates, whenever such concession is consistent with a just regard to the rights of his shareholders. The former net rate at Norfolk was \$1.80.

A TRIBUTE TO THE MEMORY OF THE LATE EVAN T. JONES.—We have received the following from Mr. T. A. Bates, of Norfolk, Va., which explains itself. Further, we can and do indorse every word of the graceful tribute thus paid to the merits of the deceased Superintendent: "Evan T. Jones, whose death occurred at Paducah, Ky., on June 11, 1887, had acted as Superintendent of the Paducah Gas Company from October, 1870, until the transfer of that plant was made by its former owners to new proprietors something over a year ago. Mr. Jones, who was a native of Wales, was born on February 13, 1822, and in early childhood (1828) came to this country, residing in and about Pittsburgh, Pa., until 1857, when he removed to Paducah, under engagement to take charge of the engines of a rolling mill which had been established at that place. The rolling mill venture, however, did not prove a success, and when the scheme failed Mr. Jones opened a gas and steam fitting shop in the city, subsequently taking part in the laying of the first gas mains put down in Paducah. The stirring events immediately preceding the war of the rebellion proved Mr. Jones to be strongly loyal to the Government, and he, with a very few others of that locality who shared his views, was saved from banishment by the opportune arrival of General Grant, who had just begun his glorious career, from Cairo,

Ills.—of course, it is understood that the people of that section of Kentucky were strongly imbued with secession ideas and aims. It is but the simple truth to say that were it not for his rather delicate physique, and the fact that a helpless family depended upon him for support, Mr. Jones would have gladly entered the ranks of those who so successfully contended for the preservation of the nation. The writer, who assisted in rebuilding the Paducah gas works—these had been destroyed during the warfare—and subsequently remained in charge of plant until 1870, at which period Mr. Jones assumed command. During these years an intimate friendship was established between the deceased and the writer, a friendship that remained unbroken up to the hour of separation enforced by death's decree. I can truly say that neither a better man nor truer friend ever lived than the one who forms the subject of these remarks. Let me here reproduce an extract from a local paper in regard to his decease, as evidence of the manner in which deceased was held by those who knew him best: 'His life has been quiet and unassuming (yet active in good works) and has been such as would lead to the impression that he had not knowingly or purposely ever committed a sinful act. He was both useful and good, setting good example to both older and younger people.' As a husband and father he was loving, kind and provident; in business, firm, just and honorable; as a friend, loyal, faithful and charitable. He was but little known to the fraternity, and that must be traced to his native modesty, which prevented or disinclined him from attendance in large assemblies; but those who were fortunate enough to call him friend will remember him until they also are no more. Having lived a Christian life, he now partakes of his reward for faithfulness unto the end."

A SUMMARY OF THE WORK OF A BUSY FIRM.—Mr. James R. Floyd, proprietor of the Oregon Iron Works, 531 to 543 West 20th street, this city, writing under date of June 22, says: "We send herewith a summary of the contracts so far secured by us during this season, and think it indicates that the gas industry is not sleeping: *Consolidated Gas Company, 14th St. Station.*—Furnishing and erecting one set of four purifiers, each 16 by 25 ft., with 20-inch connections; also iron work for 24 benches of sixes, including self-sealing mouthpiece and bridge-pipe lids. *Forty-second St. Station.*—Altering connections to two sets of purifiers (each) by removing the present 16-inch center-seals and connections, replacing the same with 20-inch center-seals, and 20 and 24-inch connections. *Forty-fourth St. Station.*—Furnishing and erecting one set of four purifiers, 24 ft. by 24 ft., with 20-inch connections; also, 24-inch connections to other apparatus. *Phila. Pa. Gas Works, Ninth Ward Station.*—Erecting new purifier house to contain set of four purifiers, each 17 ft. by 29 ft., with 20-inch connections, and Farmer's Duplex Center-Valve, for working four boxes at once. All of the above-named new purifiers will be equipped with our patent Hoisting Carriage for lifting the covers. *East Chester Gas Company, Mt. Vernon, N. Y.*—Iron work for two additional benches of sixes on the Stedman-Stanley furnace plan, and to include the Stiness main and Hutchinson tar displacing apparatus. *Standard Gas Company, 115th St. Station.*—Four multitubular condensers, and two scrubbers with 16-inch connections. We are also fitting self-sealing lids to 72 mouthpieces at North End Station of the Boston (Mass.) Gas Light Company. As, in addition to the above, more than the usual amount of repairs to benchwork is being done, you can see we do not anticipate any vacation prior to the coming October meeting." Well, Brother Floyd, you do not seem to be particularly downcast at the likelihood of losing the chance of following Messrs. Greenough, Cabot, Somerville and Morley in their flight abroad. Perhaps, however, there is a prospect of that sort in store for you next winter. Who knows?

ANNUAL MEETING, AMERICAN WATER WORKS ASSOCIATION.—We are indebted to Brother J. H. Decker, the Hannibal (Mo.) gas man, for an invitation to attend the Seventh Annual Meeting of the above-named Association, for which body he acts as Secretary. The meeting, which is to be held in the West Hotel, Minneapolis, Minn., on the 13th, 14th and 15th days of July present month, bids fair to eclipse any of the preceding sessions, and we think so because the programme calls for the reading of no less than 13 specially prepared papers. Amongst the contributors we note the name of Col. Wm. Ludlow, who proposes to talk on the subject of "Water for Public Supplies." Mr. G. W. Pearson will discuss "Natural Filtration," and Mr. A. A. Godard is to outline the "Legal Relations of Consumers and Suppliers." The titles of the other papers bespeak a plenty of interesting themes to command the attention of the members. The local committee promise a treat in the shape of an excursion to the Lakes, and they have also arranged for excursion trips to many points and places worth seeing in the immediate vicinity of the great twin cities—Minneapolis and St. Paul—of the booming North-

west. If it is possible, Brother Decker, mid-July will see us in the neighborhood specified.

DOWN THEY GO.—We understand that the Directors of the Tarrytown and Irvington (N. Y.) Gas Light Company have made a reduction of 50 cents per thousand cubic feet in the price of their gas. The former rate was \$3.

THE WATER'S FRISKY WAYS AT JOHNSTOWN, PA.—In our last we explained that owing to the overflow of water from that ordinarily peaceful stream known as Stony Creek where it passes through Johnstown, Pa., the local gas works had been unable to supply light to the Johnstownners. Mr. James Williams, Superintendent to the Company, in a letter dated June 15, kindly posts us as to the trouble in the following inanner: "The damage done to our works by the floods of the 7th inst. was very slight, merely necessitating a few hours' stoppage. In fact at the hight of the flow my holders were filled with gas, and could have delivered gas right along to the consumers, were it not for the injuries occasioned to the mains and services, owing to settling and breakage of meter connections, caused by floating debris in the cellars of houses, etc., our pipes became filled with water, thus involving us in considerable trouble. Indeed we have not yet been able to supply all our consumers. Since the bother began we have been busy night and day pumping out water and changing meters, for in many instances we found they had been completely filled up. We lost considerable gas on account of the breakages. Our pipe (a 6-inch wrought iron one) over the South bridge was struck by drift and the joints were started, being bent for about 8 inches in nearly a 1-16th bend; but although the bridge was badly wrecked the pipe remained. As we had a depth of 5 feet of water in our principal streets, I think, on the whole, we escaped remarkably well, especially as our plant is located on the bank of the Conemaugh river, half a mile above the point of junction of that stream with Stony Creek." Our readers will agree with Mr. Williams in the belief that it might have been worse with him.

BRANCHING OUT AT JAMAICA PLAIN, MASS.—President Pratt, of the Jamaica Plain Gas Light Company, having determined to supply the nearby district of Roslindale—the latter is perhaps 1½ miles distant from the Jamaica Plain gas works—with a plentiful supply of the light of the present, is now putting down the main system necessary to accomplish that object. He will also extend and perfect the general distribution system by the placing of the following sizes and lengths of pipes:

Length, in feet.	Size of Pipe.
6,000.....	8-inch.
4,000.....	6-inch.
12,000.....	4-inch,

Next year it is contemplated that the betterment in this line will be even greater than that spoken of above.

BOUGHT THEM OUT.—We understand that the proprietors of the Salt Lake City (Utah) Gas Light Company have purchased a controlling interest in the shares of the local electric light company, and while the gas men will nominally conduct the new purchase as a matter entirely separate from their gas business, in reality the arrangement can be regarded as a case of combined electric light and gas supply. The Messrs. Ellerbeck were the instigators of the purchase.

LIKEWISE AT LYNN, MASS.—A controlling interest in the Lynn Electric Light Company has been purchased by the present owners of the Lynn Gas Light and the Thomson-Houston Electric Light Companies. This purchase virtually places the local Gas Company in control of the lighting interests of the city.

GAS FOR NORTH ABINGTON AND WHITMAN, MASS.—It is reported that the negotiations looking to the erection of a gas plant for the supply of gas to the towns named have been satisfactorily concluded. The works will be constructed on a plot near the Hanover Branch Railroad, on the left bank of the small creek which divides the towns—the object being to secure a central point or station as a basis for supply. The capital stock (\$15,000) has been subscribed, each town taking \$7,500. North Abington, the larger of the two, is on the Plymouth Branch of the Old Colony Railroad, right at the junction of the latter with the Hanover Branch Railroad. It is 18 miles south-southeast of Boston.

ANNUAL ELECTION, NEWARK (N. J.) GAS LIGHT COMPANY.—The election for a Board of Directors for this Company resulted in the choice of Messrs. Eugene Vanderpool, I. M. Harrison, Theo. Runyon, E. H. Wright, J. R. Emery; R. F. Ballantine, M. L. Ward, H. Congar, and

F. Murphy. The last-named succeeded Mr. John I. Young, who refused a re-election.

RELIEF GRANTED.—Gov. Hill has signed the bill, introduced by Assemblyman Burns during the recent session of the New York State Legislature, under which the gas companies doing business in what is known as the annexed district of this city are allowed to charge consumers \$1.60 per thousand cubic feet for gas supplied. Tardy justice, but nevertheless welcome.

ANNUAL ELECTION, PAWTUCKET, R. I.—The annual election of this Company resulted as follows: Directors, Messrs. D. Goff, L. B. Darling, H. Conant, G. L. Walker, A. H. Littlefield, E. A. Perrin, and G. W. Pratt. The Directors selected the following list of officers: President, L. B. Darling; Secretary, E. A. Perrin; Treasurer, C. L. Knight; Superintendent, S. G. Stiness; Collector, W. McGregor.

CONNELLY & Co., LIMITED—This enterprising firm keeps on in the even tenor of its way, seemingly undisturbed by the multiplicity of orders which find their destination at No. 177 Broadway, this city. Among the latest shipments made by the Messrs. Connelly we note the following: *Governors*.—Two 20-inch, to Nashville, Tenn.; two 16-inch, to Erie, Pa.; 12-inch, to Municipal Company, Albany, N. Y., St. Paul, Minn., Seattle, W. T., and Zanesville, O.; 10-inch, to Allentown, Pa., and Montclair, N. J.; 8-inch, to Waltham, Mass., Allentown, Pa., Malden, Mass., and Oakland, Cal.; 6-inch, to Mattoon, Ills., Jackson, Columbus and Meridian, Miss. *Steam Jet Exhausters*.—12-inch, to Central (N. Y.) Company, and 6-inch instruments to Hastings, N. Y., and Marquette, Mich. *Iron Sponge*.—In this department of their business the Messrs. Connelly report shipments aggregating 10,170 bushels, the largest individual purchasers having been the Equitable Company, city, 4,000 bushels; Chicago, Ills., Company, 3,000 bushels; Consumers Company, Los Angeles, Cal., 1,000 bushels; Richmond, Ind., Company, 600 bushels; and Citizens Company, Lynn, Mass., 600 bushels. The remaining lots (in 100 bushels or less) were taken by ten different companies. The above record carries with it the pleasing conviction that the gas men are no longer content to allow things to remain as they were. No; the "rule of thumb" days are nearly, if not quite, over.

THE STANDARD GAS LIGHT COMPANY.—The promoters of this metropolitan enterprise are proceeding rapidly with construction work, and the station at 115th street, east of Pleasant avenue, is in a forward state. In connection with this plant we may mention that the Wilbraham Brothers (Phila., Pa.) are under contract to supply it with two (12-inch cylinder, 20-inch stroke) horizontal engines; also, two No. 7 Baker rotary or positive blowers.

AN ITEM FROM OWOSSO, MICH.—We are indebted to Mr. O. F. Webster, Supt. of the Owosso Gas Light Company, for the knowledge that at the recent annual meeting of the Company Messrs. W. M. Kilpatrick, E. A. Todd, O. F. Webster, W. C. Stevens, H. S. Dean and Ludwick Dean were elected a board of directors. At the organization meeting Mr. Kilpatrick was chosen President, and Mr. Webster was re-elected Superintendent. The Company met with a serious loss in the death (on March 16) of Mr. C. K. Leonard, formerly a director in the corporation, and a suitable set of resolutions, expressive of the esteem in which deceased was held by his former co-workers, was agreed on by the Company's executive management. Supt. Webster ought to be somewhat elated over the business showing which he was able to outline to the stockholders; for the Company, although something less than two years of age, has earned an interest return on the money invested equivalent to 6 percent per annum. That has been done, too, with gas at \$2 per thousand. No wonder that Mr. Webster was re-elected Superintendent!

THE PROPOSED NEW COMPANY AT SPRINGFIELD, MASS.—The coterie of speculators who are anxious to destroy or divide the business of the Springfield Gas Light Company, and who have adopted the name of the Equitable Gas Light Company—the coterie by this time is pretty well known in gas circles throughout the United States—appeared by counsel (Judge Gideon Wells) before the Springfield Aldermen on the evening of June 20. A large and representative audience witnessed the proceedings, which hinged on the Equitable Company's petition for the right to construct and operate a gas works in Springfield, and Judge Wells' arguments in favor of the petition did not differ greatly from those which other legal gentlemen representing the same parties have made such good use of in Baltimore, Md., Chicago, Ills., Utica, N. Y., and so on, but which did not exert a corresponding "moral effect" in Newark, N. J., or Syracuse, N. Y.. We must say, however, that the Judge, when

subjected to a very slight cross-examination, did not display that familiarity with his subject usually expected from one who knows whereof he speaks. In fact the Judge was a witness after "our own Sharp's" heart, for he (the Judge) could not say how the stock was to be subscribed for or distributed, except that "It is left to the directors to distribute it [the stock] as they see fit," from which it is fair to infer that some of the stock would be "distributed" where it would be likely to do the most good. Judge Wells, although he did not know the difference between water and oil gas, and was equally at sea regarding the cost of manufacture and the make-up of water gas in general, added that "a small subsidiary apparatus had been added to the invention (presumably referring to Jerzmanowski's invention) last year which enabled them (the petitioners) to make gas cheaper and better than that now used in Springfield." When asked how it was that Col. Graham, President of the New York Equitable Gas Company, had repeatedly asserted that gas could not be made and sold (in order to reap a profit on the transaction) at less than \$1.75 per thousand, Judge Wells replied he "neither knew nor cared." Mr. Chas. L. Long, counsel for the old Springfield Company, conducted his end of the case in a thoroughly knowing manner, and exposed the aims of those who sought to speculate on the gas supply of Springfield. The matter, however, was adjourned over to the evening of July 6, on which date we may look for something like definite results. In the meantime, if the Springfield City Council desires to know more about the operations of the promoters who now petition it for an important franchise, we suggest that an examination of the Chicago, Baltimore and Utica instances be inquired into. Should the Councilmen do so they will speedily send these roving, would-be benefactors on to "seek pastures green and fields anew."

MR. L. J. HOWARD IS NOT AFRAID OF THE GERMANIC.—Mr. L. J. Howard, of Evens & Howard, St. Louis, Mo., seems to have tired of traveling on the lordly (albeit muddy) bosom of the "Father of Waters," at least we so surmise from the fact that he took passage for Europe from this port on date of June 29. Although the Germanic did cut some queer antics a few weeks ago, Mr. Howard reasons that that past waywardness affords the best guarantee for her straight sailing in the immediate future, hence he commits his avoirdupois to her custody, and does it without a single dread. Mr. Howard will visit Great Britain and the Continent, and expects to compass the round trip in about two months.

CAPITAL INCREASED.—The capital stock of the Spencer (Mass.) Gas Light Company has been increased in the sum of \$25,000. Present capital, \$75,000.

THE EXACT FIGURES.—The lighting of the public buildings of New Brunswick, N. J., under the electric system cost \$450 last year. Gas is to be used for the next three years, and the premises will be lighted at an average cost of \$340 per annum.

THE NEW WORKS OF THE DENVER (COL.) GAS COMPANY.—Some time ago we noted that Brother Fay was about to rebuild the Denver plant. We can supplement the former statement by publishing the following particulars. The new works are located on Wewatta street, commencing at Seventh, and extend to Tenth street, near the Platte river, in the territory locally known as "the Bottoms." The Company owns 6½ acres of ground on which it will erect three buildings, one of which (the retort House) is well underway, while the foundations of the others are already laid. The retort house (120 ft. by 65 ft. and 58 ft. high) is built of brick, stone and iron, the only woodwork in the structure being that in the window frames. The roof and floors are of iron, and the carbonizing plant is of the best. A regenerative system of firing will be followed. An elevated railway, now in process of construction, begins at Seventh street, connecting with a switch from the Denver, Texas and Gulf Railroad system, and runs to the rear of the retort house, thus securing great economy in the handling of the coal. The capacity of the new retort house is placed at a maximum of one million cubic feet per diem, and not many years will pass ere that sendout figure will have been reached. The second building, to be used as a condensing and purifying house, is also to be fireproof, and is to have the dimension of 82 ft. by 65 ft. The finished gas product is to be stored in the holders occupying the old site. At some distance from the purifying house a third building, one story in height, 120 ft. by 30 ft. in dimension, and fireproof, has been arranged for. It will be devoted exclusively to the manufacture of products from coal tar. This bare outline will afford some idea of the magnitude of the gas interest of Denver, and also goes to show that Brother Fay is not sleeping at his post—in fact he never did. By way of illustrating how the Denverites hold the improvements,

we reprint the following, from a recent issue of the *Denver Daily News*: "The new plant of the Gas Company assures a light supply for Denver for many years to come, and owing to its immensity the Company can afford to sell gas at a marvelously cheap rate. There are no better buildings for the purpose in the United States, and Mr. Fay certainly deserves credit for planning and erecting them." To which we respond, "Truthfully said."

CHEAPER GAS FOR LEAVENWORTH, KANSAS.—Brother Gimper may not yet have attained complete success in extracting 6½ cubic feet of 18-candle gas to the pound of coal carbonized, but he has solved the problem of selling gas cheaply. In proof of that assertion we submit the following evidence, which takes on the form of a notice recently circulated by him among the residents of Leavenworth: "From July 1, 1887, the price of gas will be reduced to \$2 per thousand to all consumers. For the months of June, July, August and September the price of gas consumed in gas stoves will be \$1.50 per thousand, provided that 2,000 cu. ft. be used each month." The former gross price was \$2.25 per thousand, and as the discounts remain unchanged (5, 10, 15 and 20 per cent., according to quantities consumed), it will be noted that the concession is quite a liberal one, but the special rate on gas used in cooking stoves takes the prize.

TO USE THE JARVIS BOILER SETTING.—The Boston (Mass.) Gas Light Company has authorized the Jarvis Engineering Company to begin the work of arranging its boilers over the Jarvis Boiler Setting, so that coke breeze and screenings may be used for fuel. Gas companies throughout the country ought to look carefully into the Jarvis plan.

GLAD TO HEAR IT, BRO. TRACY.—We are indebted to Mr. Wm. Tracy, Supt. of the Peru, (Ind.) American Gas Company, for the following newsy letter: "To the Editor AMERICAN GAS LIGHT JOURNAL:—I have no doubt you have heard that there is some natural gas in Indiana, but perhaps you have not heard that our works have outgrown themselves. In fact I might say we are at this time building a complete new plant. Our present retort house is to be turned into a purifying house, and the new retort house will have a dimension of 50 ft. by 32 ft. by 20 ft. We will also construct new coal sheds, to be 54 ft. by 25 ft. by 18 ft. The retort house will be fitted with three arches large enough to receive 6 retorts each. The other plant will embrace purifiers (6 ft. by 8 ft.), exhauster, scrubber, condenser, etc., all complete. We hope to make gas in the new works by mid-August, and intend to supply Peru with good and cheap gas for years to come. The iron work for the construction mentioned is being furnished by the Kerr Murray Manufacturing Company, and thus adds another string to the many that will hold Brother Cressler in the State of Indiana during the present summer." This is a good illustration of the way in which business tact recoups itself. Two years or so ago the Peru Gas Company was detested by the people whom it sought to serve, and its plant, under the old management, would have been ample for years to come—that is, if the tactics which then ruled were persevered in. However, the former proprietors disposed of their property to men who did not want the earth, and now the purchasers have to double the capacity of their purchase in order to meet the wants of those whom they have dealt liberally with. Truly, common sense practice brings rich recompense.

KILLED BY ELECTRICITY.—Albert Lowell, an employee of the Troy (N. Y.) Electric Light Company, while renewing the carbons to a Congress street arc lamp, about midnight of June 11, received an electric shock that caused his death. Dr. Archambeault, who issued the death certificate, said that Lowell's back and sides were marked with a series of parallel streaks of a vivid red color.

NEW GAS COMPANY.—The Jackson (O.) Gas and Electric Light Company has been organized. Capital, \$50,000.

TO MAKE THE KORTING GAS ENGINE.—We are advised that the contract for making the Korting gas engine in this country has been awarded to Messrs. Warder, Bushnell & Glessner, of Springfield, Mass. Some time must elapse before orders for the Korting engine can be filled.

TYLER (TEXAS) TO HAVE GAS WORKS.—The Tyler City Council, on June 18, closed a contract with St. Louis (Mo.) parties for the immediate construction of a gas works at that place. Tyler is the capital of Smith county, and is 25 miles southeast of Mineola, which latter place is 77 miles east of Dallas. Mineola may soon be in the market for a like supply.

THEY BLEW UP THE GAS MAIN.—As it is in New York so also is it

in the land of the setting sun. At least we judge so from the fact that while some men in the employ of the San Francisco Bridge Company were blasting out rocks in Tennessee street, on the Potrero, San Francisco, Cal., a few days ago, a blast broke the supply main of the San Francisco Gas Light Company, and the people had to do without light.

CHEAPER GAS FOR WARREN, OHIO.—Mr. George H. Tayler, Sec. and Supt. of the Warren Gas Light Company, kindly informs us about a matter which goes to show that his Company has taken a long stride in advance. Hitherto the prevailing gas schedule in Warren called for the payment of \$2.25 (net) per thousand cubic feet in all instances in which the total monthly consumption was less than 5,000 cubic feet, but those who used over that quantity were entitled to a net rate of \$2. The new schedule, which took effect on first inst., calls for the payment of \$1.80 per thousand (net) by all classes—even the city forms no exception to the rule. The circular (a prettily arranged one) announcing the reduction concludes with the following statement: "It shall be our policy in the future to reduce the price of gas whenever we can do so with justice to our stockholders; and we wish to impress upon you the fact that the faster the consumption of gas increases in Warren the sooner can the price be again reduced." That is the way to place the situation before the notice of gas consumers, and we think the people of Warren are satisfied that Mr. Tayler means just what he says. Truly, the Ohio gas men are keeping well to the front.

CALERA (ALA.) TO HAVE GAS.—A gas works is to be built in Calera, the franchise having been granted to parties whose names are unknown to us. Calera is 63 miles north by east of Selma, and 33 miles south of Birmingham. Coal, limestone and clay deposits abound.

Cement from Blast Furnace Slag.

Engineering notes that three kinds of cement are made from blast furnace slag. The first, which is really more of a mortar than a cement, is produced by taking slag sand and grinding it with 15 per cent. of lime and 15 per cent. of oxide of iron. The grinding is generally done wet, and the product requires to be used within a few hours of being made, so that its employment is quite local. The second cement is made by grinding 75 per cent. of dry slag sand with 25 per cent. of dry slaked lime, according to Mr. Larsen's patent. It is essential that the ingredients should be reduced to a fine degree of pulverization, and that they should be intimately commingled; for this purpose the inventor uses a machine which he calls a "homogeneizer." The third cement is made according to a process brought out by Mr. Frederick Ransome. Equal weights of slag sand and chalk are ground together in a wet state, and after being dried are burned either in a kiln or revolving furnace, the process followed being similar to that used in making Portland cement. The following table gives analyses of two of the cements we have mentioned, and also of two examples of Portland cement:

Analyses of Cements.

	Lime.	Silica.	Alumina.	Ferric Oxide.	Ferrous Oxide.	Magnesia.	Water.
No. 1 cement.....	22.90 ..	21.61 ..	19.85 ..	8.80 ..	4.00 ..	4.36 ..	12.00
No. 2 (Larsen)....	41.96 ..	24.34 ..	18.74 ..	.14 ..	.27 ..	6.57 ..	4.70
Portland (No. 1) ..	59.90 ..	24.07 ..	6.92 ..	— ..	— ..	— ..	—
“ (No. 2) ..	55.57 ..	22.92 ..	8.00 ..	— ..	— ..	— ..	—
Middlesbro' slag... 40.00 ..		52.34 ..	— ..	— ..	— ..	— ..	—
“ (No. 2) 36.88 ..		51.12 ..	— ..	— ..	— ..	— ..	—
“ (No. 3) 40.45 ..		50.08 ..	— ..	— ..	— ..	— ..	—

The first and second analyses are by Mr. J. E. Stead. The non-essential ingredients are not given.

From this it will be seen that the first two cements are widely different in their chemical constitution from Portland cement, and they are still more different in their physical condition, for the lime is mostly free, the materials not having undergone the incipient fusion which Portland cement experiences. Now, in the slag the proportion of lime to alumina and silica is about as 39:51, while in cement it is as 58:31. Therefore, 100 parts of slag, including the inert matters, requires the addition of 56 parts of lime, or of 100 parts of dry chalk or limestone, to provide the constituents of a good cement, and this is the mixture used in Ransome's process. The result gives a product which exceeds the strength of Portland cement, and which improves by age. Samples seven years old are in existence, and show no signs of deterioration. Of course, the process is only commercially feasible in districts where slag is produced, but there it offers a means of turning a useless product into a valuable material, and if it be carried out by Ransome's revolving furnace, the expense for plant is comparatively small.

The Market for Gas Securities.

The city gas share market suffered in common with other shares during the recent bear onslaught. Consolidated sold down to very low figures, but at time of writing (June 30) had recovered a good portion of the decline. It is today quoted at 80 bid, and is fairly strong. Other city shares are dull and strong. It is asserted that the principal manipulator of the recent Baltimore gas deal (presumably Mr. Garret) was dealt with by those who were supposed to be in the same boat with him much after the fashion that Jay Gould is said to have dealt with Cyrus W. Field, in the late Manhattan Railroad stock operation. At any rate, Baltimore Consolidated declined from 75 to 51 on large sales, but is now quoted at 57. It is a purchase at that figure, for the Baltimore rate war must soon be decided one way or the other. The Syracuse Company's new issue of stock was readily accepted by the original holders. We note a sale at auction of 6 shares Williamsburgh gas, at 130.

Gas Stocks.

Quotations by Geo. W. Close, Broker and Dealer in Gas Stocks,
16 WALL ST., NEW YORK CITY.

JULY 2.

All communications will receive particular attention.
The following quotations are based on the par value of \$100 per share.

	Capital.	Par.	Bid	Asked
Consolidated.....	\$35,430,000	100	80½	80¾
Central.....	440,000	50	30	—
“ Scrip.....	220,000	—	47	57
Equitable.....	2,000,000	100	120	125
“ Bonds.....	1,000,000	—	113	115
Harlem, Bonds.....	170,000	—	—	—
Metropolitan, Bonds....	658,000	—	110	113
Mutual.....	3,500,000	100	102	105
“ Bonds.....	1,500,000	1000	101	—
Municipal, Bonds.....	750,000	—	—	—
Northern.....	125,000	50	30	—
“ Scrip.....	108,000	—	—	—
Yonkers.....	—	50	—	80
Richmond Co., S. I.....	300,000	50	50	—
“ Bonds.....	12,000	—	—	—
Gas Co's of Brooklyn.				
Brooklyn.....	2,000,000	25	105	108
Citizens.....	1,200,000	20	58	—
“ S. F. Bonds....	320,000	1000	—	103
Fulton Municipal.....	3,000,000	100	143	145
“ Bonds....	300,000	—	—	106
Peoples.....	1,000,000	10	60	63
“ Bonds (5's).....	368,000	—	97	—
“ “ (6's).....	94,000	—	100	—
Metropolitan.....	1,000,000	100	85	87
Nassau.....	1,000,000	25	105	—
“ Cts.....	700,000	1000	100	—
Williamsburgh.....	1,000,000	50	128	130
“ Bonds... ..	1,000,000	—	111	—
Out of Town Gas Companies.				
Boston (Mass.) Gas Co.	2,500,000	500	193	200
Buffalo Mutual, N. Y... ..	750,000	100	90	95
“ Bonds... ..	200,000	1000	95	100
Citizens, Newark.....	1,000,000	50	140	145
“ “ Bonds.	45,000	—	—	—
Chicago Gas Trust.....	—	100	61	63
Cincinnati G. & C. Co..	6,000,000	100	184	185
Consolidated, Balt.....	6,000,000	100	57	—
“ Bonds....	3,600,000	—	107	107½
Chesapeake, Balt.....	1,500,000	100	83	85
“	1,000,000	—	100	102
Consumers Toronto....	1,000,000	50	192	—
Central, S. F., Cal.....	—	—	86	100
Capital, Sacramento, Cal.	—	—	56	58
Hartford, Conn.....	750,000	25	140	142
Jersey City.....	750,000	20	168	—
Laclede, St. Louis, Mo.	2,000,000	100	125	—

Advertisers Index.

	Page
GAS ENGINEERS.	
Jos. R. Thomas, New York City	24
Wm. Henry White, New York City	24
Wm. Mooney, New York City	24
William Gardner, Pittsburgh, Pa.....	24
GAS WORKS APPARATUS AND CONSTRUCTION.	
James R. Floyd, New York City	27
T. F. Rowland, Greenpoint, L. I.....	27
Delly & Fowler, Phila., Pa.....	27
Kerr Murray Mfg. Co., Fort Wayne, Ind.....	26
Stacey Mfg. Co., Cincinnati, Ohio.....	27
Bartlett, Hayward & Co., Baltimore, Md.....	27
Morris, Tasker & Co., Limited, Phila., Pa.....	26
Davis & Farnum Mfg. Co., Waltham, Mass	15
R. D. Wood & Co., Phila., Pa.....	26
Southwark Foundry and Machine Co., Philadelphia, Pa.....	26
Bouton Foundry Co., Chicago, Ills.....	23
Smith & Sayre Manufacturing Co., New York City.....	27
PROCESSES.	
National Gas Light and Fuel Co., Chicago Ills	18
GAS AND WATER PIPES.	
Gloucester Iron Works, Phila., Pa.....	24
Mellert Foundry and Machine Co., Reading, Pa. (John Fox, Selling Agent, N. Y.).....	24
Cincinnati and Newport Iron and Pipe Co., Newport, Ky... ..	24
Ohio Pipe Co., Columbus, Ohio.....	24
Pancoast & Rogers, New York City.....	24
M. J. Drummond, New York City.....	24
Wells Rustless Iron Co., New York City.....	23
R. D. Wood & Co., Phila., Pa.....	26
GAS ENGINES.	
Schleicher, Schumm & Co., Phila., Pa.....	404
Clerk Gas Engine Co., Phila., Pa.....	19
RETORTS AND FIRE BRICK.	
J. H. Gautier & Co., Jersey City, N. J.....	22
B. Kreischer & Sons, New York City.....	22
Adam Weber, New York City.....	22
Laclede Fire Brick Works, St. Louis, Mo.....	22
Brooklyn Retort and Fire Brick Works, Brooklyn, N. Y.	22
Borgner & O'Brien, Phila., Pa.....	22
James Gardner, Jr., Pittsburgh, Pa.....	22
Henry Maurer & Son, New York City.....	22
Chicago Retort and Fire Brick Works, Chicago, Ills.....	22
Baltimore Retort and Fire Brick Co., Baltimore.....	22
Oakhill Gas Retort and Fire Brick Co., St. Louis, Mo.....	22
Evens & Howard, St. Louis, Mo.....	23
Cincinnati Gas Retort and Fire Brick Works, Cincinnati, O.	23
Emil Lenz, New York City.....	23
SCRUBBERS AND CONDENSERS.	
G. Shepard Page, New York City.....	25
R. D. Wood & Co., Phila., Pa.....	26
REGENERATIVE FURNACES.	
Bartlett, Hayward & Co., Baltimore, Md.....	17
Fred. Bredel, New York City.....	23
GAS GOVERNORS.	
T. C. Hopper, Phila., Pa.....	20
Connelly & Co., New York City.....	19
CEMENTS.	
C. L. Gerould, Manchester, N. H.....	22
GAS ENRICHERS.	
Standard Oil Co., Cleveland, Ohio.....	28
GAS METERS.	
Harris, Griffin & Co., Phila., Pa.....	30
American Meter Co., New York and Philadelphia	31
The Goodwin Gas Stove and Meter Co., Philadelphia, Pa... ..	31
Helme & McIlhenny, Phila., Pa.....	31
D. McDonald & Co. Albany, N. Y.....	31
Nathaniel Tufts, Boston, Mass.....	30
EXHAUSTERS.	
P. H. & F. M. Roots, Connerville, Ind.....	18
Smith & Sayre Manufacturing Co., New York City.....	27
Wilbraham Bros., Philadelphia, Pa.....	19
Connelly & Co., New York City.....	19
GAS COALS.	
Penn Gas Coal Co., Phila., Pa.....	29
Perkins & Co., New York City.....	28
Newburgh Orrel Coal Co., Baltimore Md	29
Despard Coal Co., Baltimore, Md.....	29
Chesapeake and Ohio R.R. Coal Agency, N. Y. City.....	29
Westmoreland Coal Company, Phila., Pa.....	29
Monongahela & Peters Creek Gas Coal Co., Pittsburgh, Pa..	29
CANNEL COALS.	
Perkins & Co., New York City.....	28
J. & W. Wood, New York City.....	28

VALVES.

Ludlow Valve Manufacturing Co., Troy, N. Y.....	20
John McLean, New York City.....	20
Chapman Valve Manufacturing Co., Boston, Mass.....	20
R. D. Wood & Co., Phila., Pa.....	26

ENGINES AND BOILERS.

Jarvis Engineering Co., Boston, Mass.....	19
---	----

PURIFYING MATERIAL.

S. H. Douglas, Ann Arbor, Mich.....	23
Connelly & Co., New York City.....	19

GAS LAMPS.

The Siemens-Lungren Co., Philadelphia, Pa.....	25
G. Shepard Page, New York City.....	24
Alho-Carbon Light Co., Newark, N. J.....	16
Standard Gas Lamp Co., Phila., Pa.....	23

PURIFIER SCREENS.

John Cabot, New York City.....	395
Geo. A. Mills, Baltimore, Md.....	23

GAS STOVES.

American Meter Co., New York and Philadelphia.....	21
The Goodwin Gas Stove and Meter Co., Phila. Pa.....	32

STREET LAMPS.

J. G. Miner, Morrisania, New York City.....	395
Bartlett Street Lamp Mfg Co., New York City.....	20

BURNERS.

G. Gefroerer, Phila., Pa.....	28
-------------------------------	----

STEAM BLOWER FOR BURNING BREESE.

H. E. Parson, New York City.....	396
----------------------------------	-----

GASHOLDER TANKS.

W. C. Whyte, New York City.....	23
---------------------------------	----

GAS FIXTURES.

Mitchell, Vance & Co., New York City.....	20
---	----

COKE CRUSHER.

C. M. Keller, Columbus, Ind.....	29
----------------------------------	----

GAS BAGS.

Peerless Manuf'g Co., New York City.....	19
--	----

ELECTRICAL APPARATUS.

Waterhouse Electric & Manufg Co., Hartford, Conn.....	16
---	----

BOOKS, ETC.

English Journal of Gas Lighting.....	15
Gas as a Source of Light, Heat and Power.....	20
Goodwin's Directory of Gas Light Companies.....	28
King's Treatise.....	30
Scientific Books.....	30
Management of Small Gas Works.....	24
Newbigging's Gas Manager's Handbook.....	30
Gas vs. Electricity.....	27

Notice to Investors.

THE CONTROLLING INTEREST

in a

Paying Gas Works

is offered for sale. The plant is located in a good manufacturing town. Satisfactory reasons given for selling. Address, MARK B. THOMAS, DUNDAS, ONTARIO.

SITUATION WANTED

A competent man desires to take charge of a small gas works. Has had Twenty Years' experience in the line indicated. Is also a good, practical mechanic. Address, "N. M." care of JOURNAL.

Engagement Desired.

The advertiser, an English Gas Engineer, age 25, seeks an engagement

As Gas Works Manager or Assistant Manager.

Thoroughly understands the manufacture and distribution of gas, and is a good draughtsman and chemist. Address 672-6t "H." care this Office.

Engagement Desired,

By a young man of several years' experience in the manufacture and distribution of coal gas, either

As Superintendent of a Small Works or Assistant in a Large Works,

Or with a Manufacturing Company or Contractors for the erection of gas works. Best of references. Address 672-2t "A." care this Office.

FOR SALE, Gas Works

IN A GROWING TOWN IN THE WEST.

The undersigned offers for sale a Coal Gas Works, in good condition, in a Western State. Population, 8,000. The reason for selling is that the owner cannot give the works his personal attention. Address 672-tf "O. E.," care this Journal.

FOR SALE, Two Sinuous Friction Condensers,

Each 1 ft. 3 in. wide by 11 ft. 3 in. long, and 18 ft. high, of sufficient capacity for 225,000 cu. ft. per day. Apply to 665-12 PETER COFFEY, Supt Gas Co., Peoria, Ill.

FOR SALE.

The St. Paul (Minn.) Gas Light Company desires to enlarge its works, and offers for sale the following apparatus, which is in perfect condition:

- Six Benches of 6's.
- Four Benches of 5's.
- One Scrubber,
4 ft. 6 in. by 4 ft. 6 in. by 15 ft.
- One 10-inch Exhauster.
- Four 8 by 12 Purifiers,
10-inch connections.
- Two 8-Horse Power Boilers.
- One 4-Horse Power Engine.
- One Coke Crusher.

THE ST. PAUL GAS LIGHT CO.,

670-4t

E. I. FROST, Sec. & Treas.

For Sale!

- One 48 by 48 Station Meter.
 - One Mackenzie Exhauster and Engine,
(Complete.)
 - One 1,000-Light Gas Machine.
- ADDRESS, NO. X--100: Chicago Tribune.

ENGLISH

"Journal of Gas Lighting."

Issued weekly. New volume commences Jan. 1, 1887. Price, \$7 per annum. Subscriptions taken by CHARLES NETTLETON, Agent for U. S. No. 115 BROADWAY, N. Y. CITY.

To All Whom It May Concern!

The SIEMENS-LUNGREN COMPANY hereby warns the public against the use of various infringing Regenerative Gas Lamps which are offered for sale. This Company has heretofore delayed bringing suit to enjoin the manufacture or importation of such infringing lamps, solely because of the practical worthlessness of the infringing devices; and although, in each instance, they infringe some one or more of the various patents owned or controlled by this Company, they have fallen into disuse sooner than any suit could be brought to a hearing. As, however, the introduction of these infringing lamps has tended to discredit the practicability of our Company's system of regenerative gas lighting, we have instructed our Attorneys Messrs. Geo. Harding, C. S. Whitman, and Silas W. Pettit, to give notice that legal proceedings will in future be taken against all such infringers.

THE SIEMENS-LUNGREN CO., 21st St. & Washington Av., Phila., Pa.

F. J. DAVIS & J. R. FARNUM,

TRUSTEES AND AGENTS FOR THE

SINUOUS FRICTION CONDENSER.

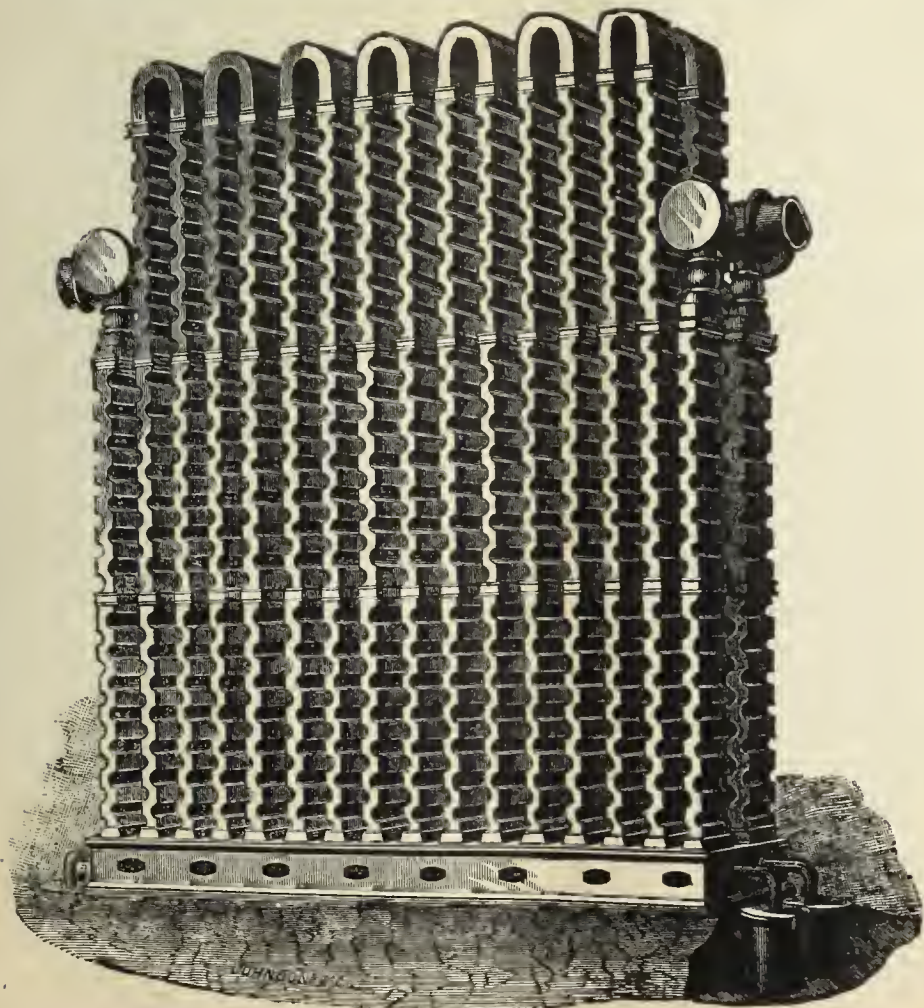

We desire to draw the attention of the gas community to the merits of the SINUOUS FRICTION CONDENSER. Companies intending to introduce new condensers into their works will do well to confer with us and examine plans and estimates before contracting for any other pattern. The FRICTION CONDENSER is now in use at the gas works located in the following places:

Portland, Me.	Brookline, Mass.	Pawtucket, R. I.	Frederickton, N. B.
Newport, R. I.	Chelsea, Mass.	Jamaica Plain, Mass.	St. John, N. B.
Gloucester, Mass.	Woburn, Mass.	Attleboro, Mass.	Paterson, N. J.
Newton & Water- town, Mass.	Peoria, Ill.	Calais, Me.	Dover, N. H.
	Clinton, Mass.	Fall River, Mass.	Waltham, Mass.
		Nassau Works, Brooklyn, N. Y.	

DAVIS & FARNUM MFG. CO.

MANUFACTURERS OF

Gas and Water Pipes,

AND

GAS AND WATER MACHINERY

OF THE MOST APPROVED PATTERN.

Also, Gasholders and Iron Roofing.

Orders from Gas and Water Companies promptly attended to.

WALTHAM, MASS.

Boston Office, Room 55, Mason Building, 70 Kilby Street.

THE ALBO-CARBON LIGHT!

The Perfection of Gas Lighting.

Producing the Highest Illumination yet obtained from Gas, and
EFFECTING A SAVING IN ITS CONSUMPTION.

It has been most effective in

Replacing Electricity,

AFFORDING A

SOFT WHITE LIGHT
OF EXTREME BRILLIANCY & POWER.

It has been most successful in

Supplanting Kerosene,

Giving Increased Light, Less Heat, and Perfect Safety
WITHOUT ADDITIONAL COST.

NOTICE.—Suits are pending in the United States Circuit Courts in Illinois and Pennsylvania against various parties for infringement of our Letters Patent No. 247,925, dated October 4, 1881, and No. 333,862, dated January 5, 1886. The first of these suits has come up for hearing, and an injunction has been granted therein. The second of said suits has not yet been reached for hearing. All persons are cautioned against manufacturing, selling, or using any apparatus or material which infringes our Patents. We intend to prosecute all parties infringing patents owned by us.

THE ALBO-CARBON LIGHT COMPANY, - - - NEWARK, N. J.,
Sole Manufacturers for the United States.

The Waterhouse System of Arc and Incandescent Lighting.

OFFICE HARLEM LIGHTING CO.,
242 E. 122d St., New York, Apr. 1, 1887. }
WATERHOUSE ELECTRIC & MFG. CO., Hartford,
Conn.—Gentlemen: It is with pleasure we
write in commendation of your system of Electric Lighting. Before entering into the business the first question to settle in our minds was, "What shall we do to give ourselves (a new company) an equal footing or, if possible, an advantage over the old and established companies in such a field as New York city," which was apparently overrun with various systems in close competition with one another. There was but one answer to this question, to wit: "Get the system that will produce the best light at the least cost." We carefully looked into the best systems, aided by those who had had much experience in such matters, and finally adopted your system; and after several months' experience in operating the same we feel it our duty to say we are more than pleased. Our customers have no complaints, and our business is increasing beyond our expectations. We have run 116 of your arc lamps from our 75-horse power engine, with three belts on one pulley and two on the other, and with 80 pounds of steam. We are fully satisfied that we produce the best light in New York, and that we do it at a cost of from 30 per cent. to 40 per cent. less than any other company for coal and repairs. We have just increased our plant to 270 lamps, with power for 700 lamps, and expect to increase to 1,000 within another year. Our station will be second to none on the continent. We think your system of regulation deserves special mention; it works instantaneously, and keeps the lights perfectly steady. The machines run cool, and no burning out of

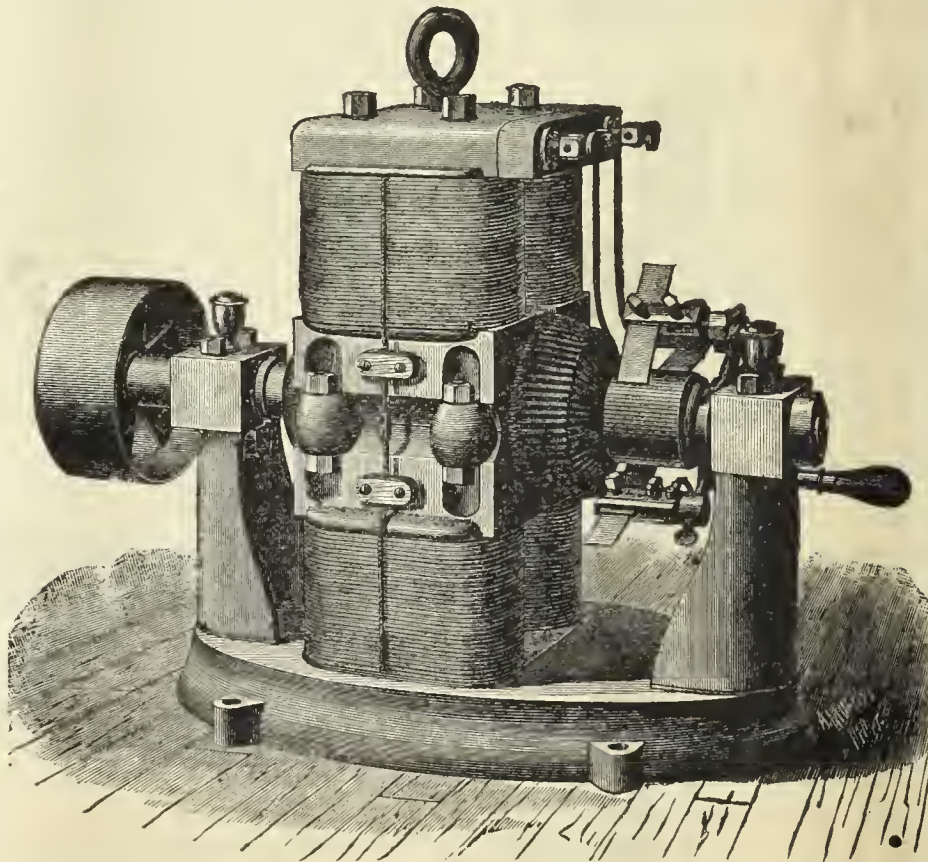

any part has occurred in either machine or lamps. The light is white and steady, producing the appearance of sunlight. We will gladly answer any inquiries in reference to your system from anyone who may wish to know its many advantages.

HARLEM LIGHTING CO.,
A. L. SOULARD, Prest.

When in Competition.

NEWARK SCHUYLER ELECTRIC LT. CO.,
NEWARK, N. J., Mar. 23, 1887. }

WATERHOUSE ELECTRIC & MFG. CO., Hartford,
Conn.—Gentlemen: The Waterhouse system has been in operation in our station for the past 2½ months, and we are pleased to say it has given both our company and our customers entire satisfaction. We doubt if the light produced is equaled in color or steadiness by any other system. We consider your three-quarter (¾) arc fully as strong as the so-called 2,000-candle power lights owned by other parties with whom we are competing, and we are daily substituting, in place of the said 2,000-candle power lamps, our three-quarter arcs with perfect satisfaction to the customers. We have thus placed 96 lamps during the past 60 days, and have orders for enough to tax our capacity, which, however, we expect to increase. Your regulator we consider deserves especial mention; it works so quick and perfect, immediately reducing the power consumed in proportion to the lights turned off. Your workmanship and material, so far as we can judge, are of the best, and we are pleased to say your claims and representations, when negotiating with us, have now been fully demonstrated.

Yours truly,
F. B. MANDEVILLE, V.-Prest. & Treas.

NOTE.—Since above date 100 more arc lights have been added to this plant.

FEATURES OF THE SYSTEM.—A White, Noiseless, Steady Arc Light; Instantaneous Automatic Regulation; Great Economy of Power.

MANUFACTURED BY

THE WATERHOUSE ELECTRIC & MFG. COMPANY,

Factory, Colt's West Armory.

HARTFORD, CONN.

BARTLETT, HAYWARD & CO.

Baltimore, Md.

Munich Regenerative Furnace, System Drs. Schilling & Bunte.

Greatest durability; minimum of attention; complete distillation in 3½ hours; 10 to 13 pounds of coke to hundred-weight of coal; no clinker; no carbonic oxide in regenerative flues.

TWO AND THREE-LIFT TELESCOPIC GASHOLDERS,

With Wrought Iron Tanks, constructed above ground, of any magnitude.

Condensers, Scrubbers, Purifiers, Bench Castings, Roofs, Boilers, Etc.

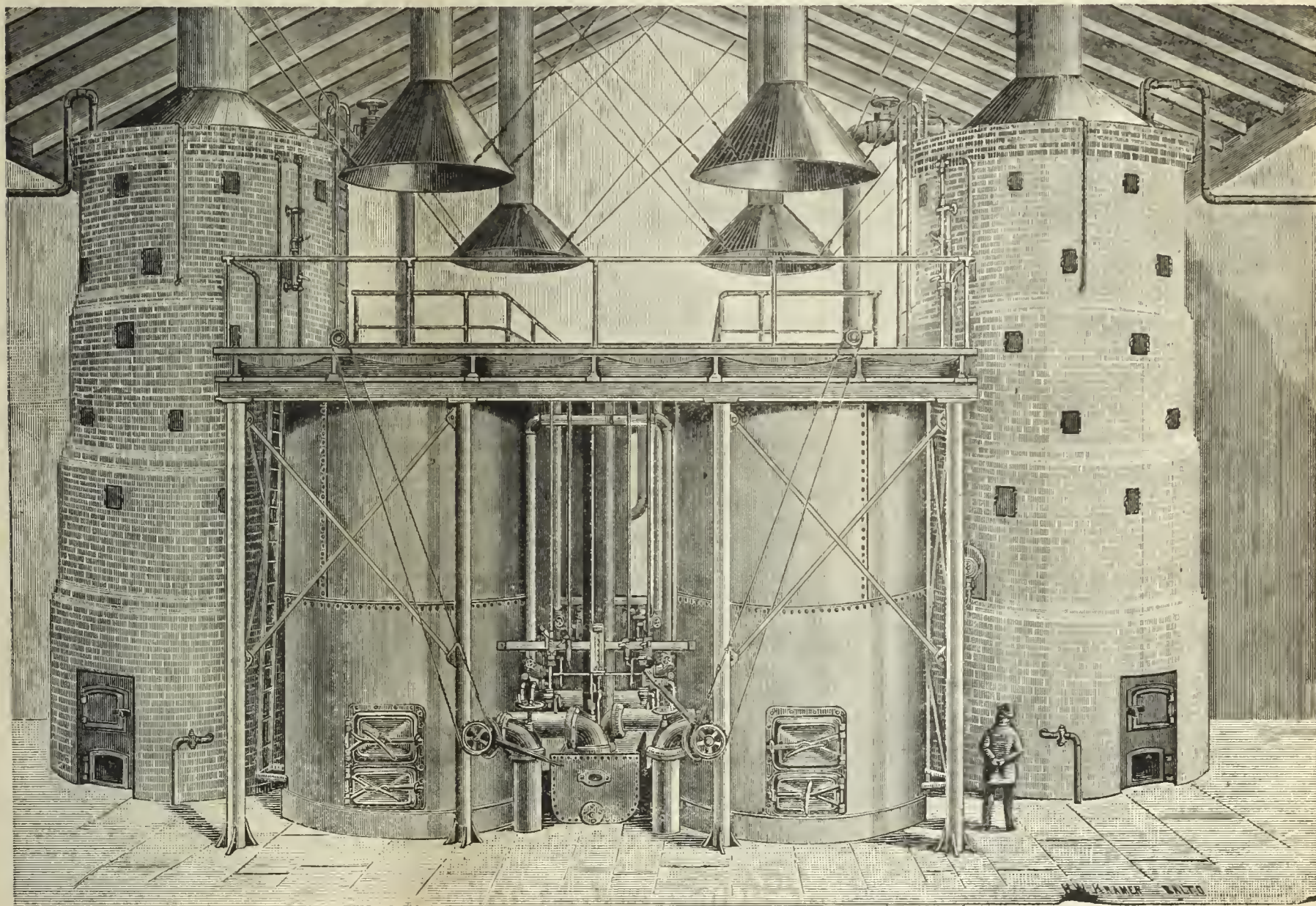

The Wilkinson Water Gas Process.

Introducing the Munich Regenerative Furnace for Coal Gas, we find on the part of many Gas Companies the desire to combine to a greater or less extent an efficient system of making high candle power Water Gas; and with a view of enabling this to be done WITHOUT EXCESSIVE CHARGES FOR PATENT RIGHTS, ETC., we have acquired, by purchase, the exclusive right to construct all the Water Gas Apparatus under the valuable "Wilkinson" Patents.

The results obtained by this Process are far better than those obtained by any other apparatus, especially where an illuminating gas of high candle power or a fuel gas of intense temperature is required.

The Process is uninterrupted, making gas of uniform quality and quantity. Its greatest advantages are maximum production with minimum material and labor, combined with great durability of apparatus.

The Process is in successful operation at the works of the N. Y. Mutual Gas Company, New York; Consolidated Gas Company, Baltimore, Md.; the Hudson County Gas Light Company, of Hoboken, N. J.; and at Rye, N. Y.

We shall be glad to give further detailed information upon application.

Sole Agents for the Celebrated Hazleton Boiler.

BARTLETT, HAYWARD & CO.

EXHAUSTERS.

EXHAUSTERS.

EXHAUSTERS.

THE ROOTS GAS EXHAUSTER.

CINCINNATI, OHIO, March 24, 1887.

P. H. & F. M. Roots, Connersville, Ind.: Gentlemen—I have the honor to say that after the continuous and uninterrupted use of your Exhausters for a period of fifteen years, it affords me pleasure to endorse them in the highest possible terms. Very respectfully,

A. HICKENLOOPER, Prest. Cincinnati Gas Co.

CINCINNATI GAS LIGHT AND COKE CO., Cincinnati, Ohio, two No. 6 Gas Exhausters, with Engine, for their new works, which, with the two No. 6 Exhausters, without Engines, at their old works, and one No. 3, with Engine for pumping, for their station at Carthage, make five Exhausters in all for this Company.

CHICAGO, ILL., March 24, 1887.

Messrs. P. H. & F. M. Roots, Connersville, Ind.: Dear Sirs—We have two of your No. 6 Exhausters at our works, which have been running for several months, and are giving very good satisfaction. Yours truly,

THEO. FORSTALL, Prest.

THE CHICAGO GAS LIGHT AND COKE CO., Chicago, Ill., two No. 6 Gas Exhausters and Engine combined on same bed-plate.

St. LOUIS, Mo., March 21, 1887.

Messrs. P. H. & F. M. Roots, Connersville, Ind.: Dear Sirs—In 1872 one of your No. 5 Exhausters was placed in these works, and worked satisfactorily. March, 1885, it was replaced by one of your No. 6 Exhausters. The latter has been in almost constant use the past two years, has worked up to all my expectations, and is to-day in apparently as good condition as when first set up. It has not cost one cent for repairs in all that time. I have also had one of your No. 1 Exhausters, with Engine on same bed-

P. H. & F. M. ROOTS, Patentees and Manufacturers, **CONNERSVILLE, IND.**

S. S. TOWNSEND, Gen. Agt., 22 Cortlandt St., N. Y.

COOKE & CO., Selling Agts., 22 Cortlandt St., N. Y.

plate, fitted with your valves and Huntoon Governor, placed in a small works under my control, and in its operation it seems as near perfection as I ever expect an Exhauster to become. Without in the least disparaging Exhausters of other makes, I may say that your Exhauster may be safely recommended as unsurpassed by any other, to those requiring such machines. Yours respectfully,

FREDERIC EGNER, Eng. and Supt.

CLEVELAND, OHIO, March 22, 1887.

Messrs. P. H. & F. M. Roots, Connersville, Ind.: Gentlemen—Concerning the Exhauster furnished this Company by you last fall, I can say but little—indeed, much need not be said. It simply does its work perfectly, and in a way that inspires confidence that it will not shirk its duty when one's back is turned. If I wanted another 1,000,000 capacity I should try and duplicate our No. 4. Very respectfully,

EDWARD LINDSLEY, Eng. and Supt.

PEOPLES GAS LIGHT CO., Cleveland, Ohio, one No. 4 Exhauster and Engine combined on same bed-plate, Pipe Fittings, Gas and Bye-Pass Valves, Governor, etc.

INDIANAPOLIS, IND., March 21, 1887.

P. H. & F. M. Roots, Connersville, Ind.: Gentlemen—The No. 4 Exhauster and Engine which you erected for us last summer has done all you claimed for it, and has given us perfect satisfaction. Yours very truly,

JAS. SOMERVILLE, Eng. and Supt.

INDIANAPOLIS GAS LIGHT CO., Indianapolis, Ind., one No. 4 Gas Exhauster and Engine combined on same bed-plate, Pipe Fittings, Gas and Bye-Pass Valves, etc. This Exhauster has a capacity of 1,000,000 cu. ft.

DURING THE PAST YEAR, THE

NATIONAL GAS LIGHT AND FUEL CO.

218 LA SALLE ST., CHICAGO,

Have Erected Twelve Sets of Water Gas Generating Apparatus under the *Springer Cupola* System. They are as follows:

Newton Illuminating Company, Newton, Kansas.—Daily capacity, 120,000 cu. ft.

Wellington Light & Heat Co., Wellington, Kansas.—Daily capacity, 120,000 cu. ft.

Chippewa Falls, Gas Light Co., Chippewa Falls, Wis.—Daily capacity, 120,000 cu. ft.

Elkhart Gas Light & Coke Co., Elkhart, Indiana.—Daily capacity, 120,000 cu. ft.

Madison City Gas Light Company, Madison, Wis.—Daily capacity, 120,000 cu. ft.

South Bend Gas Light Co., South Bend, Indiana.—Daily capacity, 250,000 cu. ft.

Sheboygan National Gas Comp'y, Sheboygan, Wis.—Daily capacity, 120,000 cu. ft.

Salina Gas Light Company, Salina, Kansas.—Daily capacity, 120,000 cu. ft.

Rathbun Company, Deseronto, Province Ontario.—Daily capacity, 80,000 cu. ft.

Jefferson City Gas Light Co., Jefferson City, Mo.—Daily capacity, 120,000 cu. ft.

Mankato Gas Light Company, Mankato, Minnesota.—Daily capacity, 80,000 cu. ft.

Minneapolis Gas Lt. & Coke Co., Minneapolis, Minn.—Daily capacity, 1,000,000 cu. ft.

1886

1886

CONNELLY & CO., LTD.,

SOLE MANUFACTURERS OF THEIR PATENTED SPECIALTIES.

"IRON SPONGE." Saves money, saves labor, and is the most efficient purifying agent ever offered as a substitute for lime. Now used *in every State in the Union*, and purifying daily over *twenty-five million cubic feet*. Should be used in every gas works. Its own saving will pay for it many times over.

AUTOMATIC GOVERNOR. Has been on the market but *two years*, and in that time has been introduced *more generally* than any invention ever designed for use in gas works. Over *one hundred* of them now in use. Sensitive; reliable; perfectly automatic; reduces leakage; satisfies consumers, and gives great relief to the Manager. No gas works is *complete* without one of these machines.

STEAM JET EXHAUSTER. Designed particularly for small works. Combines Exhaust Tube, Steam Governor, Gas Compensator, and Bye-Pass Valves in the most compact form possible; occupies but little space; uses very little steam; operated by ordinary workmen; saves formation of carbon in retorts; increases yield 10 to 15 per cent. Specially adapted for *mixing air* with oil gas. *No works* too small to use them profitably.

Prices given on all our specialties *delivered at any point in the United States*. Correspondence solicited.

CONNELLY & CO., LTD., No. 177 Broadway, New York City.

WILBRAHAM GAS EXHAUSTER

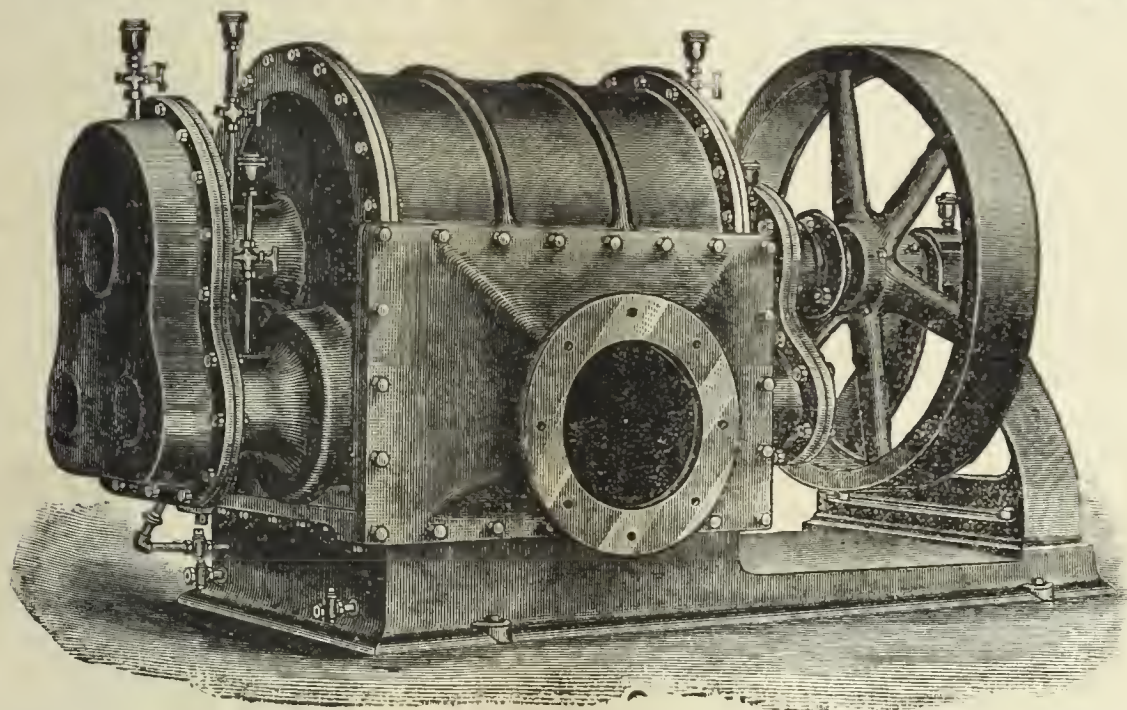

WILBRAHAM BROS.,
PHILADELPHIA, PA.

JARVIS ENGINEERING CO.,

61 Oliver St., Boston, Mass.

CONTRACTORS FOR ERECTING

COMPLETE STEAM OUTFITS FOR ELECTRIC LIGHTING STATIONS.

Steel Boilers set with Jarvis Pat. Boiler Setting,

To burn **COKE SCREENINGS** for Fuel.

ARMINGTON & SIMS CO. ENGINES,

Belted direct to Dynamoes, without using Shafting.

SEND FOR CIRCULARS.

REFERENCES — Charlestown Gas & Electric Light Co., Charlestown, Mass.; Schenectady Gas & Electric Light Co., Schenectady, N. Y.; Brookline Gas Co., Brookline, Mass.

Improved Patent
GAS BAG OR
BLADDER VALVE.

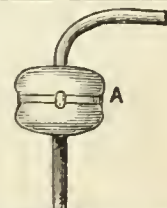

Pressure
Indicator.

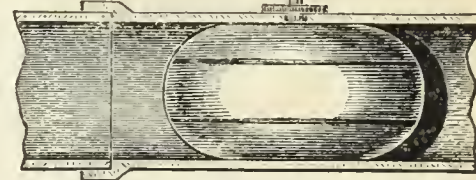

MANUFACTURED BY
PEERLESS MFG. CO., 34 Murray St., N.Y.

THE CLERK GAS ENGINE CO.,

Main Office, 1012, 1014, 1016, 1018 Filbert St., Philadelphia, Pa.

WM. W. GOODWIN, Prest.

E. STEIN, Sec.

S. LEWIS JONES, Asst. Sec.

A. J. DOTY, Supt.

The utility and convenience of the Gas Engine being no longer an open question, it only remains now for intending purchasers to select the BEST. We claim for the CLERK GAS ENGINE that it is equal to any other manufactured as regards steadiness in running, simplicity, and ease of keeping in repair, and that it gives the greatest amount of power for the least money (both in first cost and expense of running) of any engine made. In support of this claim we refer to the test of the Gas Engines made under the direction of the American Institute of New York, in December, 1885, and heretofore published in these columns. These engines are especially adapted for continuous running under heavy loads, and we can refer to Engines which have run 22 hours a day for months at a time.

Made in Sizes of 5, 10, 15, 20, and 25 Horse Power. All Engines Guaranteed for One Year.



CHAPMAN VALVE MANUFACTURING CO.,

MANUFACTURERS OF

Valves and Gates for Gas, Ammonia, Water, Etc.

Also, Gate Fire Hydrants With and Without Independent Nozzle Valve. All Work Guaranteed.

WORKS & GEN'L OFFICE:
Indian Orchard, Mass.

TREASURER'S OFFICE:
72 Kilby & 112 Milk Sts, Boston, Mass.

LUDLOW VALVE MFG. CO.



OFFICE AND WORKS,
938 to 954 River Street and 67 to 83 Vail Av.
TROY, N. Y.

How to Reduce Leakage to Its Minimum.

USE

HOPPER'S AUTOMATIC DIFFERENTIAL GAS GOVERNOR.

Needs No Attention. Simple, Reliable, Perfectly Automatic.
"Nearly Thirty in Use."

BYE-PASSES, DRY CENTER VALVES, PRESSURE REGISTERS. Also, GOVERNORS FOR STREET MAINS, *NOT DIFFERENTIAL*, and for EXHAUSTERS, GAS ENGINES, etc.

Our new Bye-Pass is threefold in its action—passes gas through, or bye-passes, or shuts off entirely. Correspondence solicited; information given. Send for circulars and testimonials.

T. C. HOPPER & CO., - - No. 2227 Wood Street, Philadelphia, Pa.

G. S. COOK, Pres. THOS. DAVENPORT (late Davenport Bros.), Sec. & Treas

BARTLETT

Street Lamp Mfg. Co.

MANUFACTURERS OF

Bartlett's Patent

GLOBE LAMPS,

FOR

Streets, Parks, Railroad Stations, Public Buildings, Etc.

LAMP POSTS A SPECIALTY.

Office and Salesroom

40 & 42 College Place, N. Y. City.

Gas Companies and others intending to erect lamps and posts will do well to communicate with us.

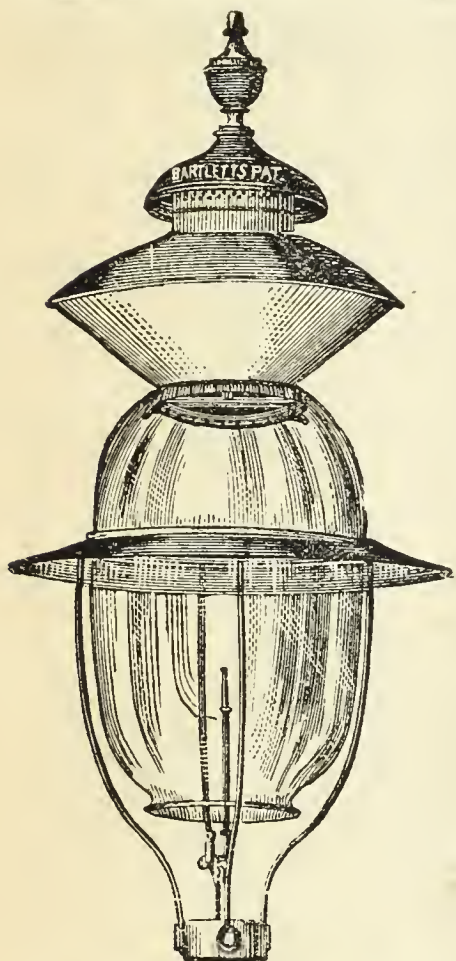

Hydraulic Main Dip Regulators, also Check Valves, Foot Valves, Yard-wash and Fire Hydrants. Send for Circulars.

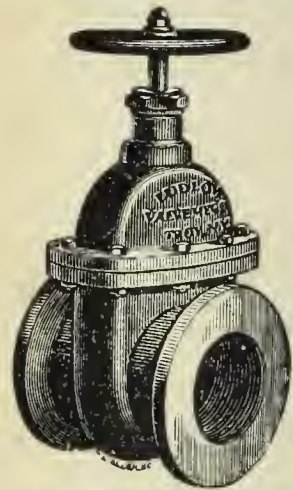

Valves.—Double and Single Gate, 1/2 in. to 48 in., outside and inside Screws. Indicator, etc., for Gas, Water, Steam, and Oil. Send for Circulars.

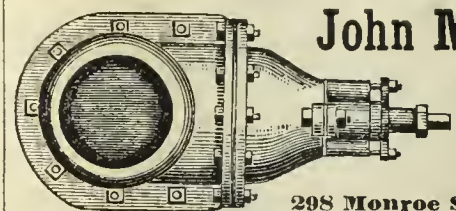

John McLean

Manufacturer of
GAS VALVES.

298 Monroe Street, N. Y.

MITCHELL, VANCE & CO.,

MANUFACTURERS OF

Chandeliers

and every description of

GAS FIXTURES.

Also manufacturers of Fine Gilt Bronzes and Marble Clocks, warranted best time-keepers. Mantel Ornaments, etc.

Salesrooms, 836 Broadway, N. Y.

Special Designs furnished for Gas Fixtures for Churches, Public Halls, Lodges, etc.

GAS AS A SOURCE OF LIGHT, HEAT, AND POWER.

By C. J. R. HUMPHREYS

A Pamphlet of twenty-nine pages, treating of the use of Gas as a source of Light, Heat, and Power.

DESIGNED FOR DISTRIBUTION BY GAS COMPANIES AMONG THEIR CUSTOMERS AND OTHERS.

Price, 10 cents each, \$5 per 100, \$50 per 1,000.

Gas Companies can have their own imprint placed on cover without extra charge. All orders to be sent to

A. M. CALLENDER & CO.,

No. 42 Pine Street, N. Y. City.

GAS STOVES.

GAS STOVES.

GAS STOVES.

THE AMERICAN METER CO.,

MANUFACTORIES,

508 to 514 West Twenty-second St., N. Y.

Arch and Twenty-second St., Phila.

Nos. 244 & 246 North Wells Street, Chicago, Ill.

AGENCIES,

No. 177 Elm Street, Cincinnati, Ohio.

Nos. 122 & 124 Sutter Street, San Francisco Cal.

No. 810 North Second Street, St. Louis, Mo.



New Design Cast Iron "Economy" Cabinet Stoves.—With Open or Closed Top.

THE COMPANY MANUFACTURES

GAS STOVES FOR COOKING AND HEATING PURPOSES,

In All Sizes, for Domestic, Restaurant, and Hotel Use.

Also,

A Variety of Apparatus for Mechanical Purposes, Using Gas as Fuel.

These Stoves may be seen in operation at our Retail Store, No. 223 Sixth Avenue, N. Y. Call and examine.

SEND FOR ILLUSTRATED CATALOGUE SHOWING THE VARIOUS STYLES AND SIZES.

RETORTS AND FIRE BRICK.

J. H. GAUTIER & CO.,

CORNER OF
GREENE AND ESSEX STREETS,
JERSEY CITY, N. J.

MANUFACTURERS OF

**Clay Gas Retorts,
Gas House Tiles,
Fire Bricks, Etc. Etc.**

Ground Clay, Fire Brick and
Fire Sand in Barrels,

J. H. GAUTIER.
C. E. GREGORY.

T. B. GAUTIER.
C. E. GAUTIER.

BROOKLYN

Clay Retort & Fire Brick Works,
(EDWARD D. WHITE & CO.)

Manufacturers of Clay Retorts, Fire Brick,
Gas House and other Tile.

VAN DYKE, ELIZABETH, RICHARDS & PARTITION STS.
Office, 88 Van Dyke St., Brooklyn, N. Y.

RETORTS AND FIRE BRICK.

LACLEDE FIRE BRICK MFG. CO.,

MANUFACTURERS OF

Fire Brick, Gas Retorts,

AND

ST. LOUIS STANDARD SEWER PIPE.

Blast Furnace and Cupola Linings, every description of Fire
Clay Material, Fire Clay Flue Linings, Chimney Tops
Dry Milled and Crude Fire Clays, etc.

OFFICE AND DEPOT

901, 903, and 905 Pine Street,
ST. LOUIS, MO.

ESTABLISHED IN 1845.

B. KREISCHER & SONS,

OFFICE FOOT OF HOUSTON ST., E.R., N.Y.

Gas Retorts,

TILES, FIRE BRICK.

AND EVERYTHING IN THE FIRE CLAY LINE.

RETORTS AND FIRE BRICK.

MANHATTAN

FIRE BRICK & ENAMELLED CLAY

RETORT WORKS.

ADAM WEBER.

CLAY GAS RETORTS

AND RETORT SETTINGS

FIRE BRICKS, TILES, ETC.,

Office and Works, 15th Street and Avenue C., N. Y.



Works,
LOCKPORT STATION, PA.

—ESTABLISHED 1864.—

JAMES GARDNER, JR.,

Successor to WILLIAM GARDNER & SON.

Office, Rooms 19 & 20, Lewis Block,
PITTSBURGH, PA, P. O. Box 373.

Fire Clay Goods for Gas Works.

CHAS. H. SPRAGUE & SON, No. 70 KILBY STREET, BOSTON, MASS., Agents for the New England States.

OFFICE, 418 to 422 East 23d St., New York.

ESTABLISHED 1856.

WORKS, PERTH AMBOY, NEW JERSEY.

HENRY MAURER & SON,

Excelsior Fire Brick & Clay Retort Works

CLAY GAS RETORTS, BENCH SETTINGS, FIRE BRICK, TILES, ETC.

CHICAGO

Retort & Fire Brick Works,

OFFICE AND FACTORY,
Clark, Forty-Fifth, and La Salle Streets,
CHICAGO, ILL.

GEORGE C. HICKS, PRES. PAUL P. AUSTIN, SEC. & TREAS.

STANDARD

Clay Retorts and Settings.

BLOCKS & TILES

of every Shape and Size to Order.

Standard Fire Bricks.

GEROULD'S IMPROVED RETORT CEMENT.

A Cement for patching retorts, putting on mouthpieces, and
making up all bench-work joints. This Cement is mixed ready
or use. Economic and thorough in its work. Fully warranted
o stick. For recommendations and price list address

C. L. GEROULD,

Manchester, N. H.

Western Agent, H. T. GEROULD, Mendota, Ill.

OAKHILL

GAS RETORT & FIRE BRICK

Works.

Proprietors,

PARKER-RUSSELL MINING & MFG. CO.

City Office, 711 Pine Street,

ST. LOUIS, MO.

Our immense establishment is now employed almost entirely in
the manufacture of

MATERIALS FOR GAS COMPANIES.

We have studied and perfected three important points. Our re-
torts are made to stand changes of temperature, the strongest
heats of the furnace, and the abrasion of feeding and emptying.
Our customers are in almost every State of the Union, to all of
whom we refer.

THOS. SMITH, Prest. AUGUST LAMBLA, Vice-Prest. & Sup

BALTIMORE

RETORT & FIRE BRICK CO.

MANUFACTORY AT

LOCUST POINT, BALTIMORE, MD.

Connection with the City by Telephone.

Clay Retorts, Blocks & Tiles,

FIRE BRICK, FIRE CLAY,

AND FIRE CEMENT.

Red and Buff Ornamental Tiles and Chim-
ney Tops. Drain and Sewer Pipe (from
2 to 30 inches). Baker Oven Tiles
12 x 12 x 2 and 10 x 10 x 2.

WALDO BROS., 88 WATER ST., BOSTON, MASS

Sole Agents the New England States.

EVENS & HOWARD,
916 Market St., St. Louis. Mo.
Works, Howard Station, Mo. Pacific R.R.

Fire Brick, Gas Retorts

AND

RETORT SETTINGS.

Sewer Pipe, 3 to 24 in. diameter.

Glass Pot Clay, Ground Fire Clay, in barrels and in bulk. All kinds of Fire Clay Goods.

Cincinnati Gas Retort & Fire Brick Works.

—ESTABLISHED 1872.—

CHAS. TAYLOR,

MANUFACTURER OF

Gas Retorts, Fire Brick, and Tile.

Blast Furnace Linings, Cupola Blocks, Boiler Tiles, Grate Settings, and Stove Linings. Fire Cement, Fire Clay, Fire Sand, and all other Fire Clay Goods.

Branch Works, New Cumberland, W. Va.

GENERAL OFFICE AND WORKS,

Burns St., Cincinnati, Ohio.

EMIL LENZ,

2 & 4 Stone St., N. Y. City.

CLAY GAS RETORTS

(ENAMELED.)

Fire Brick, Blocks & Tiles.

FIRE CEMENT, RETORT ENAMEL, RETORT CEMENT, ETC., ETC.

Regenerative and Half-Regenerative Benches.

PORTLAND CEMENT.

Correspondence Respectfully Solicited.

Bouton Foundry Co.,

FOUNDERS AND MACHINISTS,

CHICAGO, ILL.

Gas Works Apparatus,

PURIFIERS, CONDENSERS,

Bench Work,

SPECIALS, LAMP POSTS,

SCRUBBERS,

Iron Roofs and Floors.

Plans and Estimates furnished for new works or extensions of old works.

PATENTS.

FRANKLIN H. HOUGH,

Solicitor of American & Foreign Patents

925 F. ST., WASHINGTON, D. C.

(NEAR U. S. PATENT OFFICE.)

Personal attention given to the preparation and prosecution of applications for Letters Patent. All business before the U. S. Patent Office attended to for moderate fees. No Agency in the United States possesses superior facilities for obtaining Patents, or for ascertaining the patentability of inventions. Copies of patents furnished for 25 cents each. Correspondence solicited.

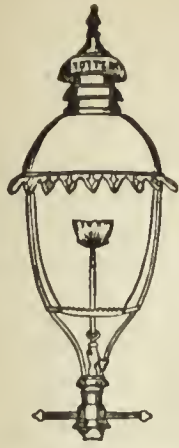

STEPHEN A. MORSE, President.
GODFREY REBMANN, Vice-Pres.

M. B. DYOTT,
Superintendent.

EDWIN F. MORSE, Secretary.
CARLTON M. WILLIAMS, Treas.

STANDARD GAS LAMP CO.,

Office, 411 Cherry St. Factory, 1101, 1103 & 1105 Frankford Av.

Philadelphia, Pa.

It is to the interest of Gas Companies and Cities to use Dyott's Patent Champion Lamps, which give double the light with the same consumption of gas, and will save 50 per cent. over others in cost of keeping in repair. Gas Companies and others intending to erect Lamps of any description will do well to communicate with us. Special Drawings furnished and Estimates given on application upon Architects', Engineers' or our Draughtsmen's Plans.

Our Patent System of Instantaneously Lighting Gas (without electricity) for R. R. Depots is unequaled. Our High Candle Power Burner is superior to the Electric Light or any other High Candle Burner. We manufacture every description of Ornamental Lamps.

KLOENNE & BREDEL

IMPROVED REGENERATIVE FURNACES.

Self-Sealing Mouthpieces & Bridge-Pipes, Retort Houses,

WASHER-SCRUBBERS,

Gasholders, and Complete Gas Works.

Refers, by permission, to Mr. Eugene Vanderpool, of Newark, N. J.; Mr. E. G. Cowdery, of Milwaukee, Wis.; and Mr. Theo. Forstall, of Chicago, Ill. For further information apply to

FRED. BREDEL, 332 East 17th St., N. Y. City.

Water & Gas Pipe.

RUSTLESS

Send for New Catalogue.

RUSTLESS

The WELLS RUSTLESS IRON COMPANY,

Nos. 7 and 9 Cliff Street, New York City.

GASHOLDER TANK CONSTRUCTION, ETC.

Gas Companies and others about to erect Gasholders will find it profitable to consult W. C. WHYTE, who for over thirty years has made a specialty of

Holder Tank Excavation and Mason Work.

Fifty tanks now in operation show the sort of work done. Address

W. C. WHYTE, No. 15 Cortlandt St., N. Y. City.

MILLS' REVERSIBLE LIME TRAY,

AND

WOODWORK

Of Every Description

NEEDED BY GAS WORKS.

SEND FOR CIRCULAR AND PRICE LIST TO

GEORGE A. MILLS,

Canton Av. & President St., Baltimore, Md.

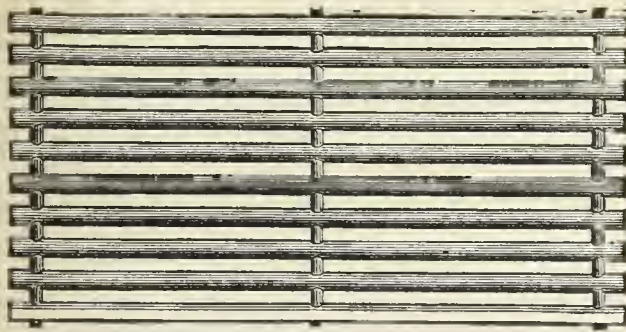

Ferric Oxide for Gas Purification.

Ferric Oxide, as ground, screened, and prepared by me for purifying purposes, has now been in use for several years by many of the gas works throughout the country, including Detroit, Chicago, Milwaukee, East Saginaw, Burlington (Iowa), Ann Arbor, etc. It has proved, as I believe, the **Most Effective and Economical Agent** now in use. I am prepared to furnish the Oxide by the 100 lbs. or in car load lots, and will be pleased to give price f.o.b. cars at Ann Arbor or at place of destination. Address

S. H. DOUGLAS, Prest. Ann Arbor (Mich.) Gas Light Co.

GAS AND WATER PIPES.

GAS AND WATER PIPES.

ENGINEERS.

SAM'L R. SHIPLEY, Pres.
HENRY B. CHEW, Treas.

JAS. P. MICHELLON, Sec.
WM. SEXTON, Supt.

GLOUCESTER IRON WORKS,
GLOUCESTER CITY, N. J.



Cast Iron Gas & Water Pipes, Stop Valves, Fire Hydrants, Gasholders. &c.
Office No. 6 North Seventh Street, Philadelphia.

MATTHEW ADDY, President.

W. L. DAVIS, Selling Agent.

GEO. P. WILSHIRE, Sec. & Treas.

Cincinnati and Newport Iron and Pipe Company,
NEWPORT, KY.

Lamp Posts
AND
BENCH CASTINGS

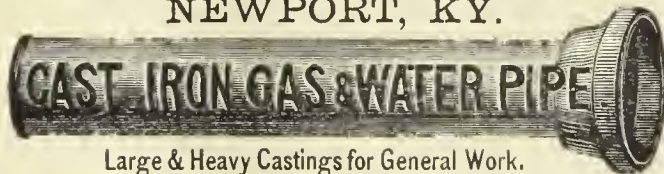

Branch
AND
SPECIAL CASTINGS

A Specialty.

Large & Heavy Castings for General Work.

FOR GAS & WATER CO'S.

Manufacture Pipe from 2 to 48 inches. All work guaranteed first quality.

Pancoast & Rogers.

WROUGHT IRON PIPE,

VALVES AND GATES,

Cast Iron Gas & Water Pipe.

28 Platt and 15 Gold St., New York.

GEO. SHEPARD PAGE,

No. 69 Wall Street, N. Y. City.

REPRESENTING

THE BOWER GAS LAMP.

C. & W. Walker's Carbonic Acid & Tar Extracting Washer

B. DONKIN & CO.'S PAT. IMP. GAS VALVE.

Young & Beilby's Patents. Henry Aitkin's Patents.

R. P. SPICE, London, Eng. HENRY SIMON, Manchester, Eng.

The Management of Small Gas Works.

By C. J. R. HUMPHREYS. Price, \$1.

A. M. CALLENDER & CO., 42 Pine St., N. Y.

P. D. WANNER, Chairman. A. H. MELLERT, Sec. & Treas.
MELLERT FOUNDRY & MACHINE CO., Ltd.
Reading, Pa.



Specials—Flange Pipe, Valves and Hydrants,
Lamp Posts, Retorts, etc.

General Foundry and Machine Work.

JOHN FOX, Selling Agent. 160 Broadway, N. Y.

THE OHIO PIPE COMPANY,

MANUFACTURERS OF

Cast Iron Gas & Water Pipe,

BRANCH AND SPECIAL CASTINGS.

Gas-House Bench Castings, Hydraulics, Lamp Posts, Flange Pipe
and Specials, Architectural Castings, Building Columns,
Joists, Cellar Grates, Sash Weights, etc.

GENERAL FOUNDERS AND MACHINISTS.

Columbus, Ohio.

M. J. DRUMMOND,



SPECIAL CASTINGS AND LAMP POSTS.
Equitable Building, 120 Broadway, N. Y.

JOS. R. THOMAS, C.E.,

May be Consulted on all Mat-
ters Relating to Gas Works
and Gas Manufacture.

ADDRESS THIS OFFICE.

WM. MOONEY

(Successor to WM. FARMER)

27 Pearl Street, N Y. City.

(One door from Whitehall Street.)

CONTRACTOR FOR THE ERECTION OF GAS WORKS, OR
APPARATUS OF ANY CAPACITY. AGENT FOR
WM. FARMER'S PATENTS.

Plans and Specifications Furnished.

WM. HENRY WHITE,

CONSULTING AND CONSTRUCTING

Gas Engineer & Contractor

Estimates, Plans, and Specifications furnished for new works or
extensions of existing works.

No. 32 Pine Street, New York City.

Correspondence solicited.

WM. GARDNER,
Gas Engineer,

Lewis Block, Room 20, Pittsburgh, Pa.

Those who intend to make alterations in existing gas plants, or
who contemplate the erection of new works, will find it to their
interest to open correspondence with the above. Plans made
and estimates furnished.

GAS LAMPS.

SCRUBBERS AND CONDENSERS.

The Siemens and Lungren REGENERATIVE GAS LAMPS.

A System of Burning Gas whereby its Illuminating Power is Increased from 300 to 400 per ct. without the Expense, Trouble and Annoyance resulting from the use of Hydrocarbon Enriching Material.

The Siemens-Lungren Company received the only Silver Medal or Highest Award for Gas Burners at the "Novelties" Exhibition of the Franklin Institute, held at Phila., Oct., '85.

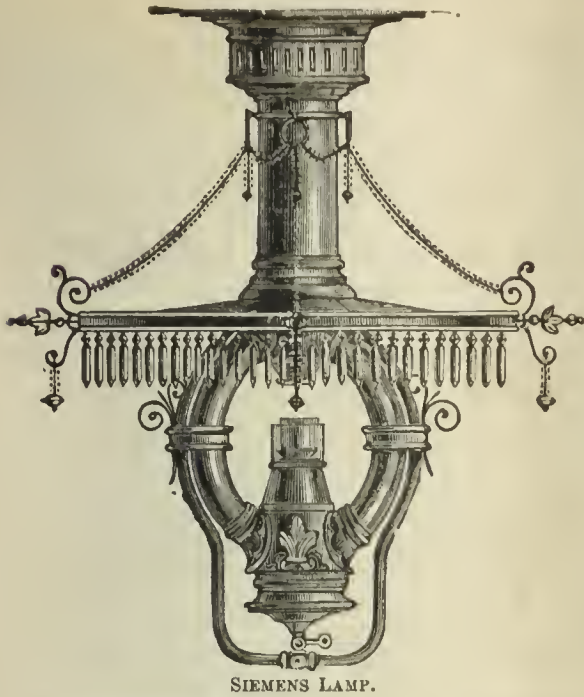

SIEMENS LAMP.

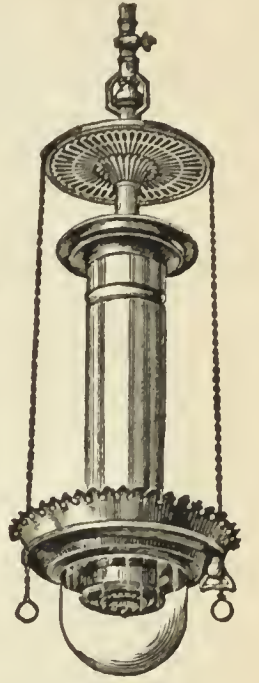

LUNGREN LAMP

THIRTEEN CANDLE POWER PER CUBIC FOOT OF GAS!

This result is obtained

SIMPLY BY THE SCIENTIFIC APPLICATION OF THE REGENERATIVE PRINCIPLE.

Consequently this largely increased illumination is always maintained without further cost and frequent attention.

THE SIEMENS-LUNCREN COMPANY,

N. E. Cor. 21st. St. and Washington Av., Phila., Pa.

THE PATENT "STANDARD" WASHER-SCRUBBER

(KIRKHAM, HULETT & CHANDLER PATENT.)

Has been adopted by gas companies in all parts of the world. Between 300 and 400 companies, with the enormous daily output of over 300,000,000 cubic feet, are now using it. "Standard" Washer-Scrubbers have been erected for the following gas light companies since Jan. 1, 1886:

WALLASEY, ENGLAND.....	750,000	cubic feet.	RICHMOND, SURREY, ENGLAND.....	1,500,000	cubic feet.
NEWARK, ENGLAND.....	350,000	"	BRIDGEPORT, U. S.....	500,000	"
BUFFALO, U. S. (MUTUAL).....	500,000	"	TORONTO, CANADA.....	1,000,000	"
BERLIN, GERMANY.....	1,250,000	"	HARTFORD, U. S.....	1,000,000	"
SO. BRISBANE, AUSTRALIA.....	300,000	"	DETROIT, U. S.....	750,000	"
LEEDS, ENGLAND.....	2,000,000	"	SINGAPORE, CEYLON.....	300,000	"
FURTH, GERMANY.....	400,000	"	BRUNSWICK, GERMANY.....	300,000	"
FREIBURG, GERMANY.....	200,000	"	LILLE, FRANCE.....	750,000	"
NINE ELMS, LONDON.....	3,000,000	"	CADIZ, SPAIN.....	300,000	"
MELBOURNE, AUSTRALIA (2).....	3,000,000	"	READING, ENGLAND.....	2,000,000	"
GLUCKAUF COKE WORKS, GERMANY.	200,000	"	LINCOLN, U. S.....	250,000	"
BOURNEMOUTH, ENGLAND.....	1,000,000	"	ST. LOUIS, U. S. (LACLEDE).....	1,000,000	"
			BROOKLYN, U. S.....	2,000,000	"
			BROOKLYN, U. S. (NASSAU).....	1,000,000	"
			DENVER, U. S.....	1,000,000	"

That this apparatus is really the *standard* is indicated by the following names of important houses who represent this invention in the different countries of the world:

FRANCE & BELGIUM, Mons. J. A. Berly, 31 Rue Boinod, Paris. HOLLAND & DUTCH COLONIES, Mess. W. Hoven & Zoon, Rotterdam.

GERMANY and AUSTRO-HUNGARY, Berlin-Anhaltische-Actiengesellschaft, Berlin, Moabit, and Dessau.

RUSSIA, Mr. F. Bley, Galernaya, 44, St. Petersburg. SPAIN, Mess. Nicolas, Chamon, Foiret & Cie., 29 Rue Claude-Vellefaux, Paris.

ITALY & MALTA, Sig. E. Canziani, 26 & 28 Portici, Vittorio Emmanuele, Genoa. Sig. Fratelli Scheuer, Via Chiaja, 124, Naples

NEW SOUTH WALES, Messrs. W. Coward & Sons, 143 Queen Victoria St., London.

NEW ZEALAND and VICTORIA, Messrs. G. D. Jennings & Co., 28 Gracechurch St., London.

Companies in the U. S. adopting this apparatus can now be assured of a market for the Ammoniacal Liquor at a remunerative price. Correspondence for purchase of "Standards" and Ammoniacal Liquor is solicited by the

GEO. SHEPARD PAGE, 69 WALL STREET, NEW YORK.

GAS WORKS APPARATUS AND CONSTRUCTION.

GAS WORKS APPARATUS AND CONSTRUCTION.

WORKS: { MILLVILLE, N. J.
FLORENCE, "
CAMDEN, "

R. D. WOOD & CO.,

OFFICES: { 400 CHESTNUT ST.,
PHILADELPHIA.

CAST-IRON PIPE 1½ to 72 Inches in Diameter.

Water Machinery and Gas Apparatus.

HEAVY CASTINGS.

HOLDERS,

PURIFIERS,

FLOORS AND ROOFS,

LAMP POSTS,

CONDENSERS,

FLANGED PIPE,

VALVES,

BENCH WORK,

FIRE HYDRANTS,

METER CASES.

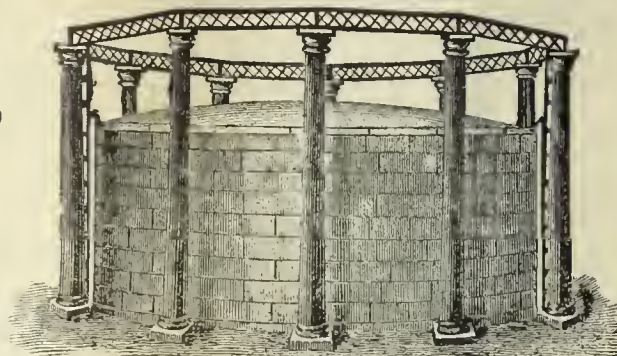
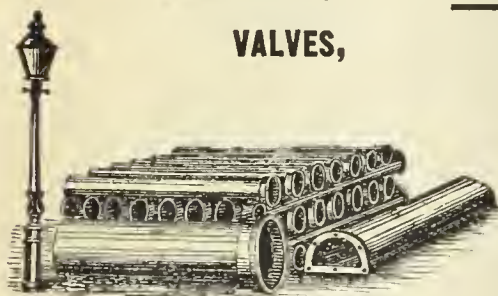

Estimates and Specifications for
NEW WORKS or **EXTENSIONS**
or **ALTERATIONS** of **OLD ONES.**

SOUTHWARK FOUNDRY AND MACHINE COMPANY,

Successors to MERRICK & SONS,

GAS APPARATUS,

Holdings, Purifiers, Washers, Etc., Etc. Boiler and Tank Work. Steam Engines.
Hydraulic Machinery. Bessemer Plants, Etc.

Washington Ave. and Fifth Street, Philadelphia, Pa.

MORRIS, TASKER & CO.,

Limited,

Builders of Gas Works,

PHILADELPHIA PA.

GASHOLDERS, PURIFIERS, SCRUBBERS, CONDENSERS, EXHAUSTERS,

Bench Castings, Iron Roofs, Lamp Posts,

VALVES, STREET MAIN SPECIALS, ETC.,

MANUFACTURED BY

KERR MURRAY MANUFACTURING COMPANY.

From 1880 to 1886, inclusive, we erected Gasholders for the following cities, viz.:

Adrian, Mich.	East End Gas Co., Pitts-	Janesville, Wis.	New Castle, Pa.	Valparaiso, Ind.
Akron, Ohio.	burgh, Pa.	Johnstown, Pa.	Niagara Falls, N. Y.	Van Wert, Ohio.
Albuquerque, N. M.	East Saginaw, Mich.	Key West, Fla.	Osawatomie, Kans.	Wabash, Ind.
Altoona, Pa.	Elgin, Ills.	La Crosse, Wis.	Pittsburgh, Pa. (2)	Waco, Texas.
Anderson, Ind.	Evanston, Ills.	Lebanon, Ind.	Plainfield, Ind.	Waukesha, Wis.
Bellaire, Ohio.	Eufaula, Ala.	Lima, Ohio.	Portage City, Wis.	Wheeling, West Va.
Birmingham, Ala.	Frankfort, Ind.	Logan, Ohio.	Sedalia, Mo.	Wellington, Kans.
Bucyrus, Ohio.	Freeport, Ills.	Louisville, Ky.	Sheboygan, Wis.	West Pittsburgh, Pa.
Canton, Ohio.	Galesburg, Ills.	Mankato, Minn.	South Bend, Ind.	Xenia, Ohio.
Circleville, Ohio.	Grafton, West Va.	Mansfield, Ohio.	South Chicago, Ills.	Youngstown, Ohio.
Colorado Springs, Col.	Greensburg, Pa.	Marshalltown, Iowa.	Springfield, Ills.	Ypsilanti, Mich.
Danbury, Conn.	Huntington, Ind. (2)	Meridian, Miss.	Streator, Ills.	
Delaware, Ohio.	Ironton, Ohio.	Minneapolis, Minn.	Topeka, Kans.	
Delphos, Ohio.	Jamestown, N. Y.	Muskegon, Mich.	Uniontown, Pa.	

Under construction, 1887.

Arkansas City, Kans.	Grand Forks, Dakota.	Mobile, Ala.	Santa Fe, N. M.	Fuel Gas and Electric Engi-
Dallas, Texas.	Grand Rapids, Mich.	Pittsburgh, Pa.	Wichita, Kans.	neering Co., Pittsburgh, Pa.
El Paso, Texas.	La Crosse, Wis.			

Estimates, with Plans and Specifications, for new or the rebuilding of old works, furnished on application. Correspondence solicited. Address

KERR MURRAY MANUFACTURING CO.,

A. D. CRESSLER, General Manager.

FORT WAYNE, IND.

GAS WORKS APPARATUS AND CONSTRUCTION.

GAS WORKS APPARATUS AND CONSTRUCTION.

JAMES R. FLOYD,

(SUCCESSOR TO HERRING & FLOYD)

Oregon Iron Works,

531 to 543 West 20th St., N. Y.

Practical Builders of Gas Works,

MANUFACTURERS OF

ALL KINDS OF CASTINGS

AND

APPARATUS FOR GAS-WORKS.

BENCH CASTINGS

from benches of one to six Retorts each.

WASHERS: MULTITUBULAR AND AIR CONDENSERS; CONDENSERS; SCRUBBERS

(wet and dry), and

EXHAUSTERS

for relieving Retorts from pressure.

BENDS and BRANCHES

all sizes and description.

FLOYD'S PATENT

MALLEABLE RETORT LID.

PATENT

SELF-SEALING RETORT LIDS.

FARMER'S

PATENT BYE-PASS DIP-PIPE.

SABBATON'S PATENT

FURNACE DOOR AND FRAME.

BUTLER'S

COKE SCREENING SHOVELS.

GAS GOVERNORS,

and everything connected with well regulated Gas Works at low price, and in complete order.

SELLER'S CEMENT

for stopping leaks in Retorts.

N. B.—**STOP VALVES** from three to thirty inches—very low prices.

Plans, Specifications, and Estimates furnished.

GAS vs. ELECTRIC LIGHT.

We would invite attention to the able and exhaustive argument of General A. Hickenlooper, President of the Cincinnati Gas Light and Coke Company, contained in a handsome pamphlet of 96 pages, entitled

"EDISON'S INCANDESCENT ELECTRIC LIGHTS FOR STREET ILLUMINATION. REPORT OF AN ARGUMENT DELIVERED BY A. HICKENLOOPER BEFORE THE COMMITTEE ON LIGHT, MUNICIPAL COUNCIL, CITY OF CINCINNATI, JULY 22, 1886."

This is a subject of special interest to all Gas Light Companies.

Prices.

25 copies..... \$7.50 100 copies..... \$22.50
50 copies..... 12.50 250 copies..... 50.00

A sample copy will be sent by mail on receipt of 50 cts.

A. M. CALLENDER, & CO., 42 PINE ST., N. Y. CITY.

THE CONTINENTAL IRON WORKS.

THOS. F. ROWLAND, Prest. WARREN E. HILL and CHAS. H. CORBETT, V.-Presds. THOS. F. ROWLAND, JR., Sec. & Treas.

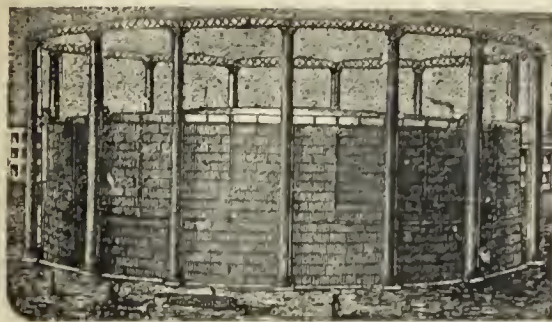

GAS HOLDERS OF ANY MAGNITUDE.

P. O. Station G., BROOKLYN, N. Y.

ENGINEERS AND MANUFACTURERS OF

Gas Holders

CONDENSERS, SCRUBBERS, VALVES,

PURIFIERS, SELF-SEALING RETORT LIDS,

Hydraulic Mains,

And all other articles connected with the manufacture and distribution of Gas.

H. RANSHAW, Prest. & Mangr. WM. STACEY, Vice-Prest. T. H. BIRCH, Asst. Mangr. R. J. TARVIN, Sec. & Treas.

STACEY MFG. CO.,

MANUFACTURERS OF

Single and Telescopic Gasholders,

IRON ROOFS, BRIDGES, LAMP POSTS,

Water and Oil Tanks, Coal Elevator Cars,

COKE CRUSHERS, BENCH CASTINGS,

And all kinds of Wrought and Cast Iron Work used in the erection of Coal and Oil Gas Works. Rolling Mill Machinery and Heavy Castings a Specialty.

Foundry:

33, 35, 37 & 39 Mill Street.

Wrought Iron Works:

16, 18, 20, 22, 24 & 26 Ramsey Street:

Cincinnati, Ohio.

1842. **DEILY & FOWLER,** 1887.

Laurel Iron Works.

Address, No. 39 Laurel Street, Philadelphia, Pa.

MANUFACTURERS OF

GASHOLDERS,

Single or Telescopic, with Cast or Wrought Iron Guide Frames.

HOLDERS BUILT SINCE 1881:

- | | | | | |
|-----------------------|---------------------------|---------------------------|----------------------------|----------------------------|
| Scranton, Pa. (2d) | Holidaysburg, Pa. | Jackson, Mich. | Montgomery, Ala. | New Castle, Pa. |
| West Point, N. Y. | Galveston, Texas (2d.) | Kalamazoo, Mich. (3d.) | Newport, R. I. | Long Island City, N. Y. |
| Fitchburgh, Mass. | Marlboro, Mass. | Glen Island, N. Y. | Portland, Oregon. | Macon, Ga. |
| New London, Conn. | Denver, Col. | Warren, Ohio. | Allegheny, Pa. (2d.) | York, Pa. |
| Derby, Conn. | Chicago, Ill. (West Side) | Bath, N. Y. | Atlanta, Ga. (2d.) | Chester, Pa. |
| Bridgeport, Conn. | Pittsburgh, Pa. (S. Side) | Lynn, Mass. | N.Y. City (Central Gas Co) | Hazleton, Pa. (2d.) |
| Allegheny, Pa. (1st.) | Pawtucket, R. I. | New Bedford, Mass. | Lynchburg, Va. (2d.) | Novelties Exh'., Phila |
| St. Hyacinth, Can. | Brookline, Mass. | Waterbury, Conn. | Saylesville, R. I. | Staten Island, N. Y. |
| Norwalk, O. | Sherbrooke, Can. | Deseronto, Can. | Rondout, N. Y. | Saugerties, N. Y. |
| Brattleboro, V | Burlington, N. J. (2d.) | Hoosic Falls, N. Y. (2d.) | Atlantic City, N. J. | Clinton, Mass. (Lan. Mills |
| Waltham, Mass. (2d.) | Bridgeon, N. J. | Bethlenem, Pa. | Augusta, Ga. | Chattanooga, Tenn. |
| West Chester, Pa. | Bay City, Mich. | Atlanta, Ga. (1st.) | Waltham, Mass. (2); | Galveston, Texas. (3d.) |
| Baltimore, Md. | Erie, Pa. | Savannah, Ga. | Mahanoy Citv. Pa. | Omaha, Neb. |

SMITH & SAYRE MFG. COMPANY,

G. PORTER, Prest.

245 Broadway, N. Y.

CHAS. W. ISBELL, Sec'y.

Machinery & Apparatus for Gas Works

Drawings, Plans, and Estimates Furnished for the Improvement, Extension, or Alteration of Gas Works, or for the Construction of New Works.

Mackenzie's Patent Rotary and Steam Jet Gas Exhausters, Governors, Compensators, Condensers, Washers, Scrubbers. Isbell's Patent Automatic Street Pressure Governor, Gas and Water Valves, Hydraulic Main Dip Regulator, Bench Castings, etc. Purifying Boxes and "Standard" Scrubbers. Isbell's Patent Self-Sealing Retort Doors.

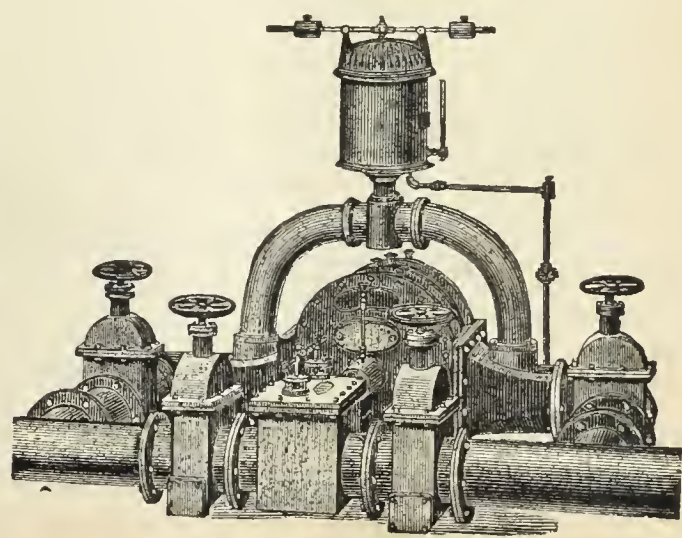

GAS COALS.

CANNEL COALS.

GAS ENRICHERS.

JAMES D. PERKINS.

PERKINS & CO.,

F. SEAVERNS.

General Sales Agents for

The Youghioghenny River Coal Company's**OCEAN MINE YOUGHIOGHENY GAS COAL.**

The Coal from the Ocean Mine (recently operated by *Messrs. W. L. Scott & Co.*, of Erie, Pa.,) is now used by all the leading Gas Companies in the United States from Maine to Texas, and is recognized as *the only reliable Youghioghenny Gas Coal.* (See Map on p. 87 of this Journal, Feb. 16, '85.)

P. O. Box 3695,
New York.**PERKINS & CO., 228 and 229 N. Y. Produce Exchange.**BEAVER STREET
ENTRANCE.**BRECKENRIDGE CANNEL,
OF KENTUCKY.**

This Colliery was re-opened in June, 1886, since which date the Cannel has been delivered to over sixty of the leading Gas Companies in this country and in Europe. As an enricher ONE TON of this Cannel will do the work of TWO TONS of any other available Cannel, and is more economical than Naptha or Oil of any character. It can be delivered in parcels of one car load or more to any point in the United States or Canada.

(See AMERICAN GAS LIGHT JOURNAL, June 16, '86, pp. 346-7.)

P. O. Box 3695,
New York.**PERKINS & CO., 228 and 229 N. Y. Produce Exchange**BEAVER STREET
ENTRANCE.**JAMES & WILLIAM WOOD,
Gas and Cannel Coal Contractors,**

No. 40 St. Enoch Sq., Glasgow. No. 2 Talbot Court, London.

Proprietors of the **BATHVILLE COLLIERIES** (which produce the celebrated **BOGHEAD CANNEL**), Shields, Shieldmuir, Drumpeller, and other Collieries. This Firm offer

STANDARD CANNELS,**Unequaled as Gas Enrichers.**

Analyses, prices, and all further information furnished on application to

Agency for U. S., Room 93, Nos. 2 & 4 Stone St., N.Y. City.**The Standard Oil Company,**

REFINERS OF

NAPTHA AND GASOLINES.

ALSO MANUFACTURERS OF

**A Special Grade of Naptha for
Gas Companies****FOR ENRICHING COAL GAS.**

Correspondence solicited.

No. 43 Euclid Avenue, Cleveland, Ohio.

To Gas Companies.We make to order **CAP BURNERS** to burn any amount under a stated pressure. Send for samples.Also, **SERVICE CLEANERS, DRIP PUMPS, and STREET MAIN PROVING APPARATUS.****C. A. GEFROER,**

248 N. 5th Street, Phila., Pa.

GOODWIN'S DIRECTORY**OF THE GAS LIGHT COMPANIES of the UNITED STATES & CANADA.**Price, **\$10.00.**

Orders may be sent to

A. M. CALLENDER & CO., No. 42 Pine Street, N. Y. City.

COKE CRUSHERS.

Newburgh Orrel Coal and Coke Co.

MINERS AND SHIPPERS OF

Mountain Brook Steam and Smithing Coals,
**NEWBURGH, PALATINE,
AURORA & TYRCONNELL
GAS COALS.**

Foundry & Crushed Coke Shipped Direct from Ovens
Mines Situated at
Newburgh, Flemington & Fairmont, W.Va.

HOME OFFICE,

33 S. Gay St., Baltimore.

CHAS. MACKALL, Gen. Mangr.

CHAS. W. HAYS, Agent in New York,

Room 147, WASHINGTON BUILDING, No. 1 Broadway.

Shipping wharves at Locust Point, Baltimore.

THE DESPARD COAL COMPANY

OFFER THEIR SUPERIOR

DESPARD COAL

To Gas Light Companies and Manufacturers of Fire Clay Goods
Throughout the Country.

ROUSSEL & HICKS, } AGENTS. { BANGS & HORTON,
71 Broadway, N. Y. } 16 Kilby St., Boston.

Mines in Harrison Co., West Va. Wharves, Locust Point, Balt.

Company's Office, 15 German St., Baltimore, Md.

Among the consumers of Despard Coal we name: Manhattan
Gas Light Co., N. Y.; Metropolitan Gas Light Co., N. Y.; Jersey
City, (N. J.) Gas Light Co.; Washington (D. C.) Gas Light Co.;
Portland (Maine) Gas Light Co. Reference to them is requested.

GAS COALS.

GAS COALS.

THE
PENN GAS COAL CO.

OFFER THEIR

Coal, Carefully Screened & Prepared for Gas Purposes.

Their Property is located in the Youghiogheny Coal Basin, near Irwin and Penn Stations on the
Pennsylvania Railroad, and on the Youghiogheny River.

Principal Office:

209 SOUTH THIRD STREET, PHILA., PA.

Points of Shipment:

Pennsylvania Railroad Piers; Greenwich Wharves, Delaware
River; Pier No. 1 (Lower Side), South Amboy, N. J.

Chesapeake & Ohio Railway Coal Agency,

FOR THE SALE OF THE

**Superior Kanawha Gas Coals, Cannelton Cannel,
Also, SPLINT AND STEAM COALS,**

From the Kanawha and New River Regions, on the line of the Chesapeake & Ohio R'way.

C. B. ORCUTT, Sales Agent. | OFFICE, 150 BROADWAY, N. Y.

FRANCIS H. JACKSON, Prest. EDMUND H. MCCULLOUGH, V.-Prest. CHAS. F. GODSHALL, Treas. H. C. ADAMS, Sec.

THE WESTMORELAND COAL CO.

Chartered 1854.

Mines situated on the Pennsylvania and the Baltimore
and Ohio Railroads, in Westmoreland County, Penn.

POINTS OF SHIPMENT:

PHILADELPHIA, BALTIMORE, SOUTH AMBOY, N. J.,
WATKINS (SENECA LAKE), N. Y.

Since the commencement of operations by this Company its well-known
Coal has been largely used by the Gas Companies of New England and the
Middle States, and its character is established as having no superior in gas-
giving qualities, and in freedom from sulphur and other impurities.

Principal Office, 224 South 3d St., Phila., Pa.

A. M. SCOTT, PRESIDENT. A. DEMPSTER, C.E., SECRETARY. W. K. GILLESPIE, TREASURER.

MONONGAHELA AND PETERS CREEK GAS COAL CO.,

PRODUCERS OF

Coal Bluff Gas Coal.

MINES LOCATED ON THE MONONGAHELA DIVISION OF THE PENNSYLVANIA RR.,
IN THE CENTRAL PORTION OF THE PITTSBURGH COAL FIELD.

Points of Shipment—Buffalo, Cleveland, Erie, Chicago, New Orleans.

Since the introduction of Coal Bluff Gas Coal it has taken rank among the few first-class Gas Coals, and ac-
knowledges no superior in gas-giving qualities, ease of working, quality of coke, and freedom from impurities.

Milwaukee Agents, F. R. BUELL & CO., - - - Milwaukee, Wis.

General Office, 43 Sixth Ave., Pittsburgh, Pa.

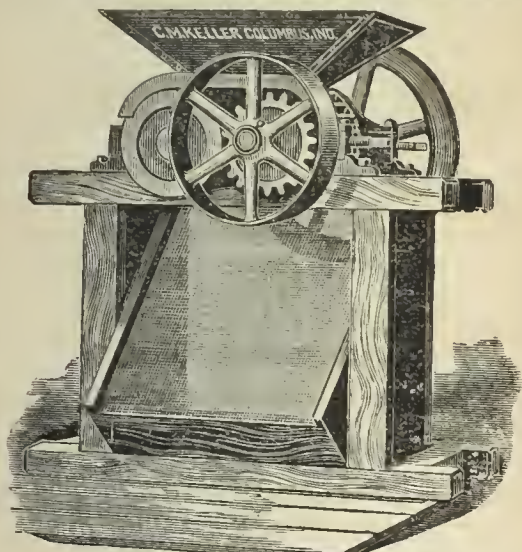

Keller's Adjustable Coke Crusher.

SIMPLE, STRONG, AND DURABLE.

C. M. Keller, Sec. & Supt. Gas Lt. & Coke Co. Columbus, Ind.

Correspondence Solicited.

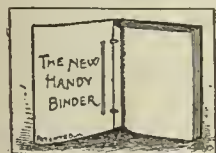

**THE NEW
HANDY BINDER.**

This article may be described as elegant
in appearance, strong, durable, and possessing many special
qualities of its own. It allows the opening of the pages per-
fectly flat, whether one or several numbers are in the binder.
Any number can be taken out and replaced without disturbing
the others. The papers are not mutilated for subsequent bind-
ing in permanent form. The binder is supplied with gilt side
title, and is an ornament to any desk or reading table. The
JOURNAL, filed in the Handy Binder, becomes a volume of great
value, always convenient for instant reference. Handy Binder,
Postage paid, \$1.00.

A. M. CALLENDER & CO., 42 Pine St., N. Y.

GAS METERS.

GAS METERS.

GAS METERS.



INTERNATIONAL--1876--EXHIBITION.

The U. S. Centennial Commission

HAVE DECREED AN AWARD TO

HARRIS, GRIFFIN & CO.,

Twelfth and Brown Streets, Philadelphia, Pa. No. 49 Dey Street, N. Y. City, and No. 75 North Clinton Street, Chicago, Ill.

FOR THE FOLLOWING REASONS :

The Exhibit consists of a Series of METERS from the Largest Size Station Meters for the use of the MANUFACTURE OF GAS, to those for the use of the ORDINARY CONSUMER. The Instruments are WELL MADE, RELIABLE as to INDICATION, and embody a number of sundry improvements which, with the general character of the Exhibit, entitle the whole to commendation.

Attest—J. L. CAMPBELL,
Secretary, pro-tem.

Signed—A. T. GOSHORN,
Director General

J. R. HAWLEY,
President

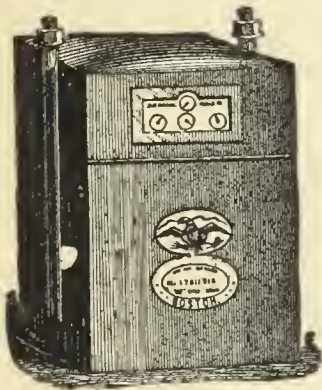

Dry Gas Meter.

With 39 years' experience and the best facilities for manufacturing, is enabled to furnish reliable work and answer orders promptly.

NATHANIEL TUFTS,*No. 153 Franklin Street, Boston, Mass.,*

MANUFACTURER OF

DRY GAS METERS.

Station Meters of any Capacity.

Test and Experimental Meters, Pressure Registers, Pressure Gauges, Pressure and Vacuum Gauges.

METER PROVERS, PHOTOMETERS, STREET LANTERNS, ETC., ETC.

Patent Cluster Lanterns for Street Illumination.

SCIENTIFIC BOOKS.

We are prepared to furnish to Gas Managers, and others interested in the topics treated of, the following books, at prices named :

KING'S TREATISE ON THE MANUFACTURE OF COAL GAS. Three vols.; \$10 per vol.	PRACTICAL TREATISE ON HEAT, by THOMAS BOX. Second edition. \$5.	THE GAS MANAGER IN THE LABORATORY, by a Practica Student. 8vo., Cloth. \$1.50.
GAS MANUFACTURE, by WILLIAM RICHARDS. 4to., with numerous Engravings and Plates, in Cloth binding. \$12.	GAS WORKS—THEIR ARRANGEMENT, CONSTRUCTION, PLANT, AND MACHINERY. \$8.	THE DOMESTIC USES OF COAL GAS, AS APPLIED TO LIGHTING, by W. SUGG. \$1.40.
THE GAS ANALYST'S MANUAL, by F. W. HARTLEY. \$2.50.	COAL; ITS HISTORY AND USE, by PROF. THORPE. \$3.50.	DISTILLATION OF COAL TAR AND AMMONIACAL LIQUOR by GEO. LUNGE. \$8.50.
TECHNICAL GAS ANALYSIS. \$2.80.	THE GAS WORKS OF LONDON, by COLBURN. 60 cents.	A TREATISE ON THE COMPARATIVE COMMERCIAL VALUES OF GAS COALS AND CANNELS, by D. A. GRAHAM 8vo., Cloth. \$3.
GAS MANAGER'S HANDBOOK, by THOS. NEWBIGGING. \$4.80.	THE GAS FITTER'S GUIDE, Showing the Principles and Practice of Lighting with Coal Gas, by JOHN ELDREDGE. 40 cents.	GAS AS A SOURCE OF LIGHT, HEAT, AND POWER, by C. J. R. HUMPHREYS. 10 cents.
GAS CONSUMER'S GUIDE. \$1.	GAS WORKS, AND MANUFACTURING COAL GAS, HUGHES. \$2.20.	GAS COMPANIES DIRECTORY. \$10.
A GUIDE TO GAS LIGHTING. 40 cents.	THE MANAGEMENT OF SMALL GAS WORKS, by C. J. R. HUMPHREYS. \$1.	GAS VERSUS ELECTRIC LIGHT. 50 cents.
GAS MEASUREMENT AND GAS METER TESTING, by F. W. HARTLEY. \$1.60	MANUAL FOR GAS ENGINEERING STUDENTS, by D. LEE, 40 cents.	PURIFICATION OF COAL GAS, by R. P. SPICE. 8vo. \$3.
GAS CONSUMER'S HANDBOOK, by WILLIAM RICHARDS, C.E.; 18mo., Sewed. 20 cents.	HOW TO MANAGE GAS, by F. WILKINS. Paper. 20 cents.	
A PRACTICAL TREATISE ON GAS AND VENTILATION with Special Relation to Illuminating, Heating, and Cooking by Gas, by E. E. PERKINS. \$1.25.		

The above will be forwarded by express, upon receipt of price. We take especial pains in securing and forwarding any other Works that may be desired, upon receipt of order. All remittances should be made by check, draft, or post office money order.

A. M. CALLENDER & CO., No. 42 Pine Street, New York.**KING'S TREATISE ON COAL GAS.**

The most complete work on Coal Gas ever published. Three vols., bound \$30.

A. M. CALLENDER & CO., No. 42 Pine Street, New York.

GAS METERS.

GAS METERS.

GAS METERS.

GEO. J. MoGOURKEY, Pres. WM. H. MoFADDEN, Vice-Pres. (Phila.) WM. N. MILSTED, Gen. Supt. & Treas. (New York) WM. H. DOWN Sec.

AMERICAN METER COMPANY,

WET AND DRY GAS METERS.

PRESSURE REGISTERS.

METER PROVERS.

STATION METERS.

PRESSURE & VACUUM REGISTERS.

PORTABLE TEST METERS.

EXHAUSTER GOVERNORS.

PRESSURE & VACUUM GAUGES.

EXPERIMENTAL METERS.

DRY CENTRE VALVES.

CRESSON GAS REGULATORS.

AMMONIA TEST METERS.

GOVERNORS FOR GAS WORKS.

MARSLAND WATER METERS.

BAR AND JET PHOTOMETERS.

Manufactories:512 W. 22d St., N. Y.
Arch & 22d Sts., Phila.**GAS STOVES,**SUGG'S "STANDARD" ARGAND BURNERS,
SUGG'S ILLUMINATING POWER METER,
Wet Meters, with Lizar's "Invariable Measuring" Drum.**Agencies:**177 Elm Street, Cincinnati.
244 & 246 N. Wells Street, Chicago.
810 North Second Street, St. Louis.
122 & 124 Sutter St., San Francisco.**HELME & McILHENNY,**

(Successors to Harris & Brother. Established 1848.)

GAS METER MANUFACTURERS,

CONTINUE AS HERETOFORE AT THE OLD ESTABLISHMENT.

Nos. 1339 to 1349 Cherry Street, Philadelphia, Pa.,

To Manufacture Wet and Dry Gas Meters, Station Meters, Experimental Meters, Meter Provers, Center Seals, Pressure Registers

GOVERNORS, INDICATORS, PHOTOMETERS, & ALL OTHER KINDS OF APPARATUS FOR USE IN GAS WORKS.

From our long practical experience of the business, and from our personal supervision of all work, we can guarantee all orders to be executed promptly and in every respect satisfactorily.

WM. WALLACE GOODWIN, Prest. and Treas.

WM. H. MERRICK, V.-Prest.

S. L. JONES, Sec.

S. V. MERRICK, Supt.

THE GOODWIN GAS STOVE AND METER COMPANY,

Successors to W. W. GOODWIN & CO.

1012, 1014 and 1016 Filbert St., Phila., Pa.

142 Chambers St., New York.

76 Dearborn St., Chicago, Ill.

WALDO BROS., Agents, 88 Water St., Boston.

MANUFACTURERS OF THE "SUN DIAL" GAS STOVES, FOR COOKING AND HEATING PURPOSES.

Dry and Wet GAS METERS, Station Meters (Square, Cylindrical or in Staves) Glazed Meters, King's and Sugg's Experimental Meter Post Meters, Etc., Etc., Meter Provers (sizes 2, 5 and 10 feet), Pressure Gauges of all kinds, Pressure Registers, Pressure and Vacuum Registers, Pressure Indicators (sizes 4 inch, 6 inch and 9 inch), King's Pressure and Vacuum Gauges, Dry and Wet Centre Seals, Dry and Wet Governors, Exhauster Governors, Photometers of all descriptions. Letheby's Sulphur and Ammonia Test Apparatus complete—also Testing and Chemical Apparatus of all kinds, and of the most perfect description, for all purposes relating to Gas.

GOODWIN'S IMPROVED LOWE'S JET PHOTOMETER.

Agents for Brav's Patent Gas Burners and Lanterns.Special attention to repairs of Meters, and all apparatus connected with the business.
All work guaranteed first class in every particular, and orders filled promptly.G. B. EDWARDS, Mang'r, New York.
E. H. B. TWINING, Mang'r, Chicago.
Represented by S. S. STRATTON.**D. McDONALD & CO.,****GAS METER MANUFACTURERS.**

(Established 1854.)

51 Lancaster St., Albany, N. Y.

34 & 36 West Monroe St., Chicago, Ill.

STATION METERS, EXPERIMENTAL METERS, METER PROVERS, PRESSURE & VACUUM REGISTERS, PRESSURE GAUGES, ETC.

Also STAR GAS STOVES, RANGES, and HEATING STOVES.

We use only the very best materials, and employ the most skilled labor, and by our long experience (32 years) and personal supervision of every detail, we feel justified in assuring the public that our goods will give perfect satisfaction. Every Meter emanating from our establishment will bear the State Inspector's Badge, and will be fully warranted by us. Our Annual and Calendar will be sent to Gas Companies upon application.

GAS STOVES.

GAS STOVES.

GAS STOVES.

THE GOODWIN GAS STOVE AND METER CO.,

1012-18 Filbert St., Phila., 142 Chambers St., N. Y., 76 Dearborn St., Chicago.

Agents, WALDO BROTHERS, 88 Water Street, Boston.

WM. W. GOODWIN, PRES. & TREAS.
W. H. MERRICK, VICE-PRES.
LEWIS JONES, SEC.
SAMUEL V. MERRICK, SUPT.

SOLE MANUFACTURERS OF THE

G. B. EDWARDS, Mang'r, N. Y.
E. H. B. TWINING, Mang'r, Chicago.
Represented by S. S. STRATTON.

"SUN DIAL" GAS STOVES

The Most Economical, Efficient, and Durable Gas Stove Made.

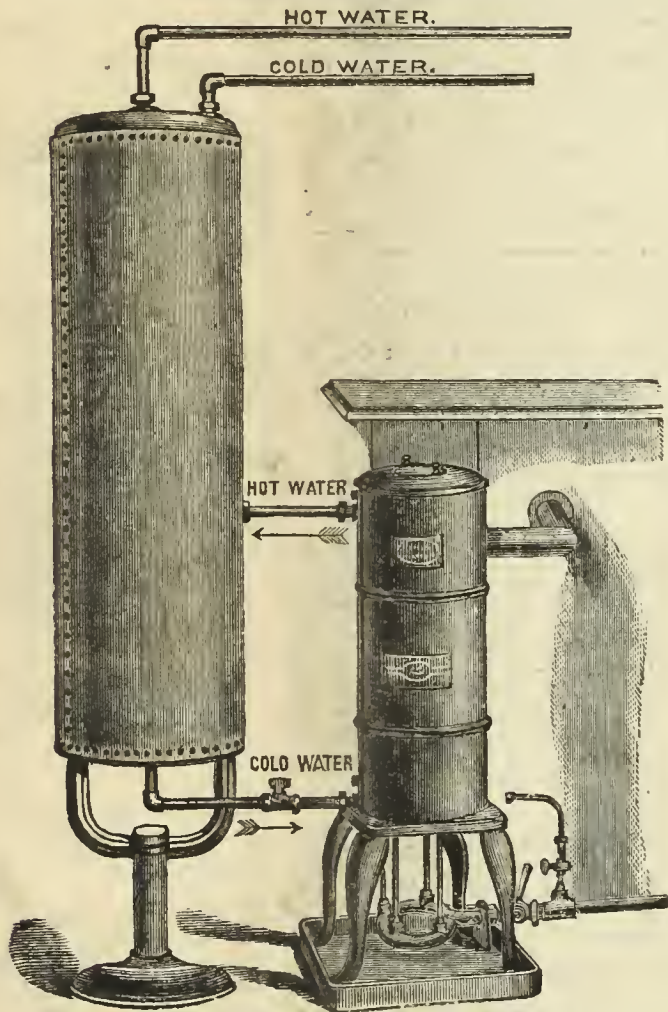

I.—Safety Hot Water Generator and Boiler.

Safety Hot Water Generator and Boiler.

Cut I. represents our Safety Gas Hot Water Generator and Boiler, arranged for home use. This most easy, quick, and economical way of preparing a warm bath, or for heating water for any domestic purpose, entirely supersedes any necessity for the use of ranges or stoves—a great comfort, particularly in hot weather. The boiler being self-filling, as the hot water is drawn off, can never become empty, thus preventing the possibility of any accident.

We beg to call attention to the cast iron pan which is now attached to the legs of the Generator (see illustration). This is to catch the drippings in the coil, which many persons suppose come from a leak, when in fact they are produced by condensation. This condensation is caused by the hot flame coming in contact with the coil filled with cold water.

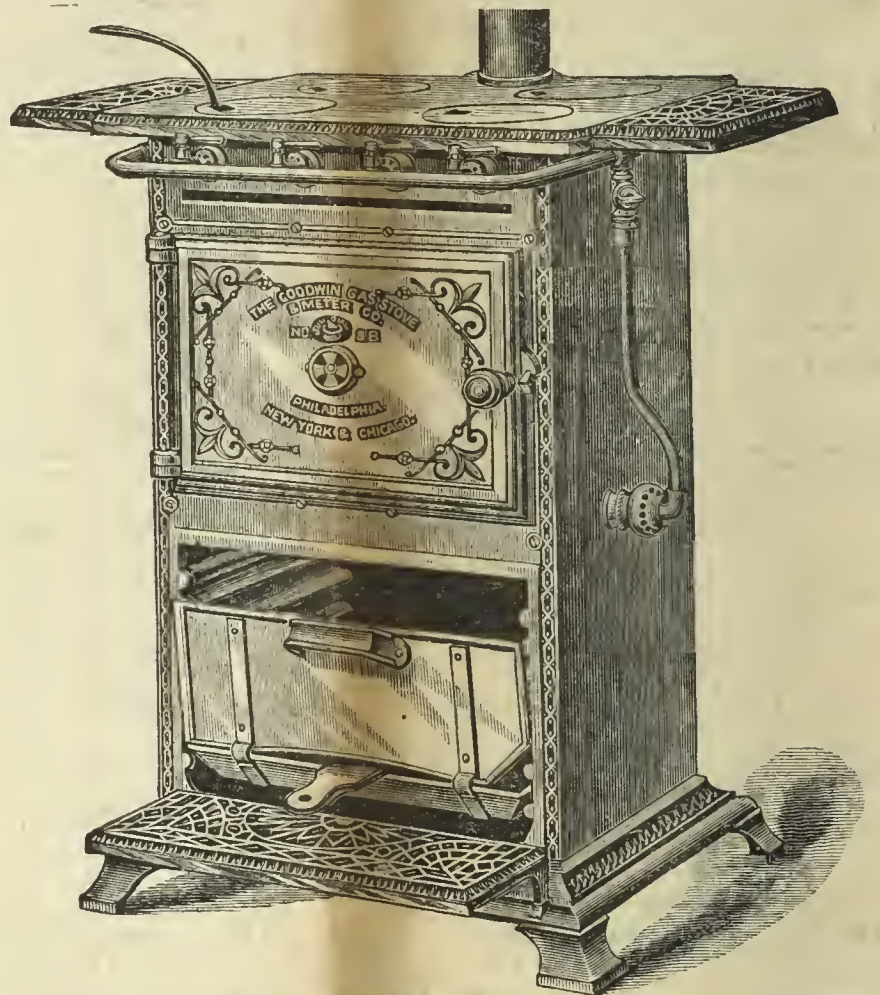

II.—Gas Cooking Stove No. 8 B.

New Style Gas Cooking Stove.

Cut II. represents our New Style Cooking Stove. As will be seen, it has an ornamented cast iron base and front, and extension shelves. The oven burner, which is atmospheric (unless otherwise ordered), is of an entirely new and improved pattern (patent applied for). The ovens are of greater capacity than those of the old style. The top, in conjunction with the outlet pipe, is designed to carry off all products of combustion; hence the outlet pipe must be connected with a flue, or the stove will not work properly.

This Stove has 4 boiling burners in top of hot plate. All fittings are nickel plated. We are making this style of Cooking Stove in the following sizes—viz., No. 7 B, No. 8 B, No. 9 B, and No. 10 B.

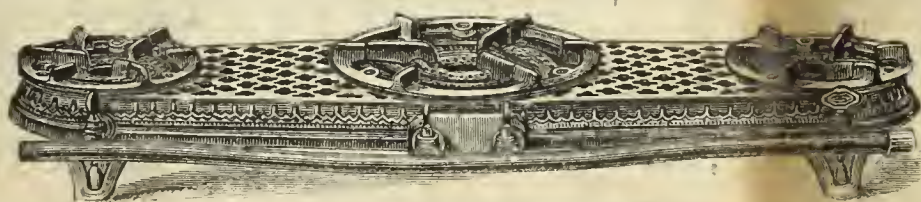

III.—Improved Hot Plate, No. 108.

New Style Hot Plates.

Cut II. represents our New Style of Hot Plates, of which we are making No. 106 (two small boiling burners), No. 107 (two medium sized boiling burners), and No. 108 (two medium and one large boiling burner). See new Catalogue and Price List for further particulars.

THE AMERICAN

GAS LIGHT JOURNAL

PUBLISHING OFFICE No. 42 PINE STREET

DEVOTED TO THE INTERESTS OF ILLUMINATION, VENTILATION, WATER SUPPLY AND DISTRIBUTION, & GENERAL SCIENCE.

VOLUME XLVII.—No. 2.
Whole No. 674.

NEW YORK, SATURDAY, JULY 16, 1887.

{ \$3 PER ANNUM,
IN ADVANCE.

A. M. CALLENDER & CO., Proprietors. C. E. SANDERSON, Manager.
JOS. H. THOMAS, C.E., Editor. T. J. CUNNINGHAM, Asst. Editor.

ENTERED AT THE POST OFFICE AT NEW YORK, N. Y.
AS SECOND CLASS MATTER.

Published on the 2d and 16th of each month, at No. 42 Pine Street, N. Y.

Terms of Subscription, Including Postage.—For the United States and Canada, \$3 per annum. European countries, \$3.50 (15 shillings—18 francs). All payments to be made in advance. Single copies, 15 cents.

Remittances should be made either by post-office order, registered letter, or bank draft on New York, payable to the order of A. M. Callender & Co.

Correspondence.—Wishing to make this JOURNAL a gazette of intelligent discussion to those of our readers who may wish to gain or give information on the subjects to which its columns are devoted, correspondence is solicited for publication from all who make the study of those subjects a pleasure or a profession.

The American News Company, Nos. 39 and 41 Chambers street, New York, are agents for this JOURNAL. Newsdealers will send orders to them.

Collections are invariably made directly from this office, for subscriptions, advertisements, etc. We have agents to solicit the same, but they are not authorized to receipt for money.

Books.—We will forward by express, at publisher's lowest rates, any book—scientific or otherwise—to any address in the United States or Canada. No books will be sent C. O. D.

CONTENTS.

An Asterisk (*) denotes an illustrated article.

EDITORIALS—

In Regard to the Proposed American Gas Institute..... 33

A Sample of the Gas Made by the "Baby Process"..... 34

Tenth Annual Meeting of the Western Gas Association—Official Report—Continued from page 8..... 34

Discussion on Mr. B. E. Chollar's Paper on the Rule of the Inverse Squares*
—Jottings from Rome, Italy, by E. Schinrock—Discussion—Furnishing Gas without a Holder, by J. W. Dunbar, New Albany, Ind.—Election of Officers
—Response of the President-elect—Report of Committee on Place of Meeting
—Election of Honorary Members—An Amendment to the By-Laws—Letter from Mr. R. Spencer, Burlington, Iowa.

A Glance at Some Past Projects for the Manufacture of Oil Gas, by N. H. Humphrys..... 39

* Tube Cutting and Screwing Machine..... 41

The Electric Light at the Suez Canal..... 41

Regulating the Storage of Inflammable Substances in the District of Columbia..... 41

Notes from the West, by "Retort"..... 42

ITEMS OF INTEREST FROM VARIOUS LOCALITIES..... 43

Adding to the Kerr Murray Company's List—After the Lighting—New Gas Works—Changes at Westerly, R. I.—The Duluth (Iowa) Plant Extensions—A Sult Compromised—Killed by Electricity—Marinette (Wis.) to Have Gas—Suits for Infringement—To be Lighted by Electricity—Superfluous Electric Lights—Cheaper Gas for Pontiac, Mich.—Named as Gas Inspector—At Greater Length—Lighted by Electricity—Parting with More of its Gas Stock—The Springer Gas Apparatus—Bro. Stein Sails for Europe—Mr. Hopper's New Venture—A Tribute to Their Late Manager's Worth—No Opposition Charter for Dubuque, Iowa—Purchased—Cheaper Gas for Gloucester, Mass. New Plant—Bro. Harbison Goes to Europe, by Proxy—And yet Another—A Superintendent for Springfield, Mass.—To Purchase the Plant.

The Market for Gas Securities..... 45

IN REGARD TO THE PROPOSED AMERICAN GAS INSTITUTE.

Perhaps the most interesting paper read at the May meeting of the Western Gas Association was that contributed by Mr. Frederic Egner, Engineer and Superintendent of the Laclede Gas Company, of St. Louis, Mo. That gentleman hardly requires a formal introduction to our readers, for they have often read in our columns articles from his ready pen, and which articles, we venture to say, have been perused with pleasure and studied with profit by the members of the fraternity. Mr. Egner's communications, aside from any consideration of their technical application, certainly carry the impression that their writer has no twofold purpose to serve; in other words, that he honestly means that which his language expresses. Now, with such an understanding of the author's straightforwardness, we take it for granted that his paper on a proposed American Gas Institute (it will be found in our issue for June 2, pp. 344-5-6) has been carefully read and digested by the fraternity, and that they are now ready to make intelligent and positive response to the questions contained in the circulars which the Committee, appointed by the Western Association on the subject, are now mailing to every gas company in the country.

The circular letter proposes five questions, and of these we reproduce the following:

II. Does the proposed scheme look feasible to you?

III. If not as a whole, which would you favor most—the union for mutual defense, or the establishment of a bureau of investigation for the spreading of useful knowledge, as proposed in the paper mentioned?

IV. Will your Company contribute towards the support of such an institution; and, if you can, please state for how long, and how much to begin with?

It goes without saying that these queries should not be very difficult to answer, for the discussion at St. Louis showed quite clearly that nearly all those present entertained decided opinions on the subject. In respect to question No. II., we believe that, as a whole, a divided answer may or must be given; therefore we can at once take up No. III. The idea of a union for mutual defense is by no means a new one, for that scheme has been broached at divers periods in the gas history of the country. In fact, at one time it seemed as if the plan were about to be accomplished, but the surface signs were fallacious, for when the negotiations seemingly approached the point where a tangible organization was to be made, differences of opinion regarding the levying and collection of the assessments, caused a decidedly sudden abandonment of the scheme. Perhaps the future may witness a more cohesive frame of mind on the part of the fraternity in regard to the system of a "defensive League," but the working members of the profession, being pretty well posted now about the jealous way that capital resents any interference with its disposition and government, are not likely to lend their aid any longer in the furtherance of a project that, after all, is not a prime personal factor in the conduct of their respective trusts. Coming to the second clause of the third question, "the establishment of a bureau of investigation for the spreading of useful knowledge," there can be but one answer thereto. Could such an institution be established—and we not only think it can, but that it eventually will be formed—the resultant

benefits from its working would seem to be absolutely immeasurable. Take, for instance, the deliberate opinion put forth by Mr. F. C. Sherman, of New Haven, Conn., during the discussion on this end of the Egner proposition. Mr. Sherman is not, as a general thing, given to the practice of speaking positively on mooted points—for he is rather conservative in his opinions—but here we find him willing to commit himself most decidedly on what we must look as a new departure. Quoting Mr. Sherman's judgment in the premises, we find that he said: "If we could apply to such an Institute for information in regard to any old or new process or invention brought before us, it would save our companies thousands of dollars each year." Other speakers preceded and followed him with remarks of a similar import. Now we think we are not far wrong in believing that as these gentlemen spoke so also will the majority of those to whom the committee circulars are addressed reply. The annual money assessment required to carry on the work of the Institute will be very small—in fact, infinitesimal when the value received therefor is estimated. Speaking for ourselves, we heartily favor the Egner project, and firmly believe that it is certain to become an accomplished fact. In conclusion we would ask that all those who receive a copy of the circular shall lose no time in making a reply thereto, even should some feel obliged to dissent to its propositions.

A SAMPLE OF THE GAS MADE BY THE "BABY" PROCESS.

We have hitherto given some account of the arguments put forth in favor of their plaint by the parties who are anxious to obtain a franchise for the right to construct and operate a gas works in opposition to the old Springfield (Mass.) Gas Light Company, and the truth is told when we say that the preliminary hearings did not disclose anything that differed materially from the usual stock arguments, so often heard on like occasions before scores of Council Boards in as many different sections of the country. The latest proceedings before the Springfield Board, however, have reversed this monotony, for these have introduced to us a somewhat remarkable pair of analyses, an examination of which will reveal to the student that some illuminating gases are fearfully and wonderfully made.

The local public interest that attaches to the present gas controversy at Springfield was amply shown by the large attendance of visitors during the sittings of the City Council during the evenings of July 6 and 7—both sessions lasted until midnight—and perhaps the residents of that charming city are now aware that the business of gas manufacture is a somewhat complicated affair. But aside from the value of the hearing, in respect of its tendency to act as an educator of the public in ways that are gaseous, we submit that some of the evidence adduced ought to go far towards causing many a gas engineer to think that a gas containing 29.39 per cent. of ingredients, which at best (or worst) are worthless as parts of a compound supposed to be manufactured for the ultimate purpose of producing light, is well entitled to the claim of being made under a "baby process." During the hearing Mr. W. A. Allen, Superintendent to the Company now supplying gas to Albany, N. Y., gave strong and positive testimony in regard to the merits of the "baby process" gas—that gas is used in Albany—but his testimony was confined to general statements. Indeed, Mr. Allen did not seem to know much about the Albany Company's capital, was equally at sea in point of figures concerning the economy of the process, and failed to remember distinctly the names of the constituents of the gas as shown by analytical tests. Mr. Long, of counsel for the Springfield Company (and he is ever ready to assist a brother engineer in distress) kindly came to Mr. Allen's aid, and supplied him (and the Council) with the results of two tests of Albany "baby process" gas. The determinations were made by Prof. C. W. Hinman, Gas Inspector for the State of Massachusetts, the examined product having been taken from different Albany levels. The figures are as follows:

Constituents.	First Test.	Second Test.
Illuminants.....	20.22	20.56
Marsh gas.....	25.21	25.56
Hydrogen.....	24.24	24.78
Carbonic oxide.....	1.56	.71
Nitrogen.....	19.43	18.98
Oxygen.....	4.46	4.32
Carbonic acid.....	4.88	5.09

From an inspection of the above is it to be wondered at that Mr. Allen was all at sea in respect to the constituents of the Albany product? Even the layman who looked over Prof. Hinman's figures might be excused for asserting that that "baby" had been prematurely born, and that said minor would need considerable reconstruction to enable it to escape from that condition of innocuous desuetude into which many other gaseous visions (so full of promise in their early youth) have faded.

[OFFICIAL REPORT.—Continued from page 8.]

Tenth Annual Meeting of the Western Gas Association.

HELD AT ST. LOUIS, MO., MAY 11, 12 AND 13, 1887.

SECOND DAY—MORNING SESSION.

Discussion on Mr. B. E. Chollar's Paper on the Rule of the Inverse Squares.*

Mr. McIlhenny—I would like to ask whether Mr. Chollar claims that the old and accepted rule of measuring light is incorrect. Instead of the rule of the square of the distances it seems to me that he has established another rule, or that of the square of the diameters of the spheres.

Mr. Chollar—I do not quite get your idea.

Mr. McIlhenny—I understood you to say that the square of the diameters of the spheres, instead of the square of the distances, is the proper rule of measurement.

Mr. Chollar—It is the square of the distances of the light from any given point. If there is a light at A and another light at B, there must

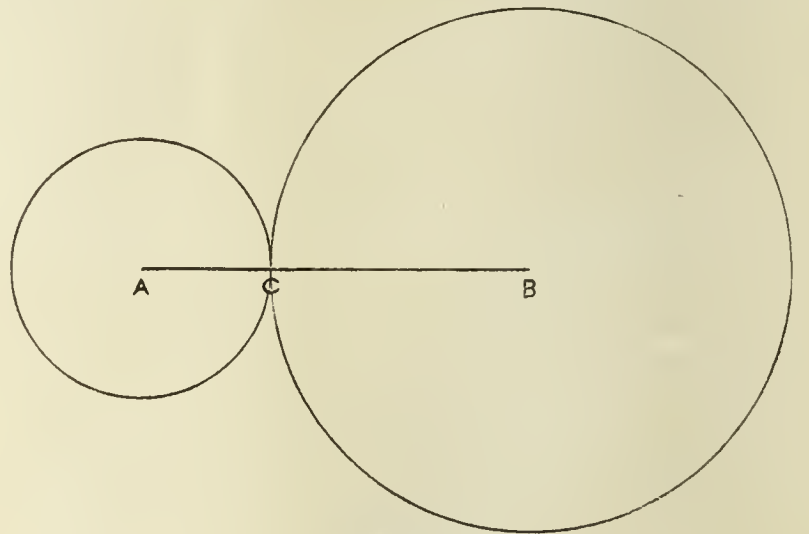

Diagram I.

be a point where the light is equal, and the intensities of those lights will be equal to the diameters of the squares.

Mr. McIlhenny—So that your theory really does not alter the old calculation?

Mr. Chollar—No. Although a sphere can have more than one point, yet if you consider the light to increase in magnitude then it is no longer

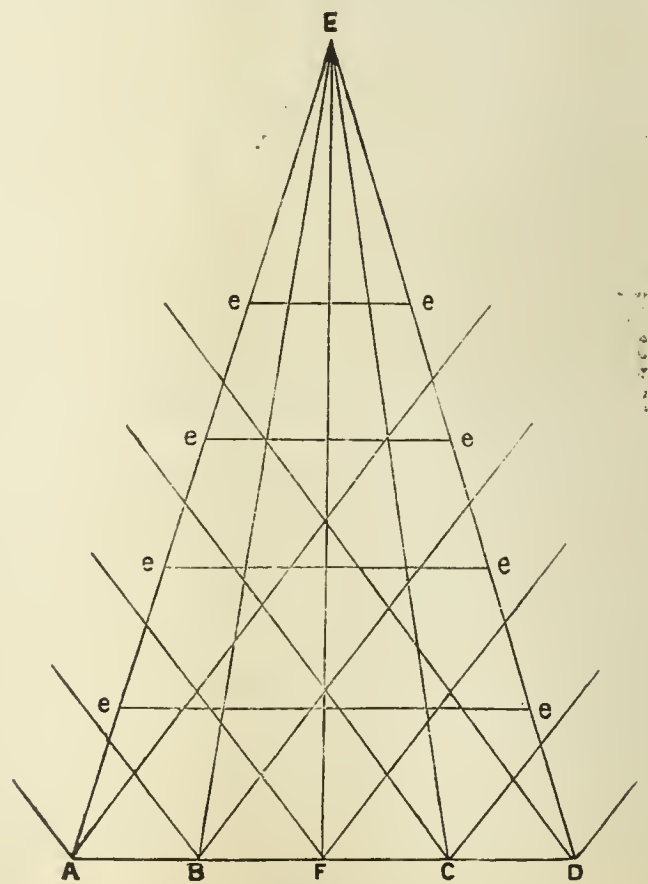

Diagram II.

a point. While there are rays that radiate from every possible point of that line, EF, there is one ray from each point which will pass through any point, for instance, through E, and consequently there will be a series of convergent rays passing, through any point in the diameter,

* For paper, see ante, p. 7.

from *E* to *F*. Now, the sections of these triangles being proportioned to the distance, and since every ray that passes in the direction of this point must keep within this triangle, it follows that the aggregate number of wave vibrations must be the same here [referring to diagram], because since they can neither get in nor out, they must necessarily stand in that triangle, and the total number of wave vibrations being so concentrated, the quantity of light is consequently independent of the distance.

Mr. McIlhenny—Therefore you reason that the intense arc light does not pass its rays as far as those from gas light.

Mr. Chollar—They diminish more rapidly. One follows the rule of inverse squares, while the other does not. The arc light approximates a point where nearly all the rays are diverted. It has no convergent rays—because the size of the light is so small—consequently that practically follows the law of inverse squares, and decreases very rapidly. But in a light like the Siemens-Lungren, or one with a large area, and having divergent rays at each point, although the intensity increases in proportion to the squares, yet the aggregate of light holds its own, and is independent of the distance.

Mr. McIlhenny—I rose to thank Mr. Chollar for his paper; and while I do say that those papers hitherto read by him have been of interest, I think his present contribution, and particularly the concluding remarks, must have been pleasing to us all. The gentlemen here who represent the gas interests should read it carefully and apply it to their business. I think that gas suffers a great deal, and in many ways, from the imperfect methods of consuming it. Mr. Chollar said, the full value of gas light is not received by those who pay for it. For instance, look at the gas fixtures in this room! Can anything be worse? The fixtures are at fault. All those solid balls—I suppose they are intended for ornamentation—beneath the globe are mistakenly placed. Then, the ground glass globes are also out of place—that they are not clean is another mistake. The heavy globe holders are in error. The less there is about a chandelier, by way of fixture and color of globe, the better will be the light. Enough attention is not paid to the location of the light itself. These are exceedingly valuable considerations, and deserve the attention of all engaged in the gas business. I have known instances where people who were paying for a large gas blaze, in a chandelier hung 8 or 10 feet from the floor, and were not getting as satisfactory results from that light as they would secure from a single bracket light. They would perhaps be better satisfied with 1 burner on a bracket than with 3 or 4 lights from a chandelier, hung in the center of the room, and surrounded by improper fixtures. Therefore, all such suggestions are exceedingly valuable. The more that such information is disseminated by the gas fraternity the more you will popularize the use of gas. Such practical suggestions will tend to reduce gas bills, and I have never yet seen a gas man who did not regret the fact when he knew that the bills rendered for gas were too large. I always regret seeing a man's bill larger than I think it ought to be; and when it is small it always gives me pleasure. Such suggestions popularize the use of gas, and the profits come back to us in the long run. I think that one of the most serious evils we suffer from today is this thing of defective service. If greater attention were given to locating the lights where they ought to be placed, gas bills, as a rule, would be reduced, and the people would be better satisfied. We should not expect our consumers to be satisfied with half-way service. They ought to have the best, and when they have the best they will be willing to pay for it. I think that this paper will draw attention to a subject which has needed more extensive attention than has been accorded it in the past.

Mr. Chollar—It would be a very great advantage if we could add 40 or 50 per cent. to our yield, but do we not practically accomplish the same result if we can develop 40 or 50 per cent. more light from our present yield? If we can do that, and without additional cost, gas would certainly prove to be the conqueror in its contest with the electric light. No one can deny that one Lungren burner will, in practice, easily displace 2½ incandescent (16-candle power) lamps; and this would make it appear that there is something wrong with the photometer in its capacity as a measure of light.

Mr. McIlhenny—You often have noticed how brilliant the incandescent light seems to be when shining through the small globe that incloses it. The electrical promoters see to it that the glass is clear, so that no obstruction is offered to the transmission of the rays of light through the glass. I think it important that the attention of members should be called to these very practical suggestions with regard to the light that might be (but which is not) obtained from gas; in other words, to the fact that we may increase by 40 or 50 per cent. the light developed, which will be substantially equivalent to an increase of 40 or 50 per cent. in the yield.

Mr. Chollar—I would like to call attention to the fact, as it appears to

me, that our estimate of the actual size of incandescent and arc lights is quite deceptive, being largely dependent on the irradiation effect on the observer. If, for instance, we look at the new moon we seem to find that the bright part of it looks larger than the dark part. That, so far as I have been able to discover, is due to a sort of defect in the eye—the intense light blurs a little on the retina. It might be illustrated by means of penmarks on paper. On smooth calendered paper the pen makes a fine or clean-cut ink mark; but if drawn on blotting paper the mark spreads somewhat. So the impression of light on the eye spreads a little, and a very bright light looks really larger than it actually is. I think there is a good deal of truth in the idea that in this respect the incandescent light swells up (like a cat's tail) and looks much larger than it really is. The filament in the incandescent light is quite small, but when it becomes illuminated it looks ten times as large as it actually is. It is an illusory light.

Mr. King—In former discussions on this subject the question whether an equal size of flame gave an equal volume of light, or whether water gas, under the photometer, would give a candle power equal to coal gas, or whether it would diffuse as far, or further, than coal gas was considered. I believe that as high authority as could be obtained on the question decided that it would not.

Mr. Chollar—If the product of the intensity and size is the same, a large light can be equal to a small light; but the factors will be different, or exactly as with the electric current. With certain power it can be of high potential and small current, or of low potential and large current. It is just like the blow of a hammer. A heavy blow of a small hammer will correspond to the light blow of a heavy hammer. They will not be identical, but the effects will be the same. Although the small water gas light will not be identical with the larger but less intense coal gas light, the energy of the total light given would be the more satisfactory because of its uniformity.

Mr. Boardman—I think the point that Mr. Chollar makes with regard to the areas of light may be illustrated in this way. [Here the speaker referred to Diagram I.] Let *B* represent an arc light of high intensity and small local point, while *A* represents the center of a gas flame. Then the small intensity will be represented by the area with *AC* as a radius. That is now the only point of that gas flame which is being measured against the local point of the arc light. If you give that flame any magnitude, each point of that flame illuminates an area equal to the surface of the circle *AC*, so that from each point of it you may draw a circle, which may be illustrated in this way. [See Diagram III.] Now,

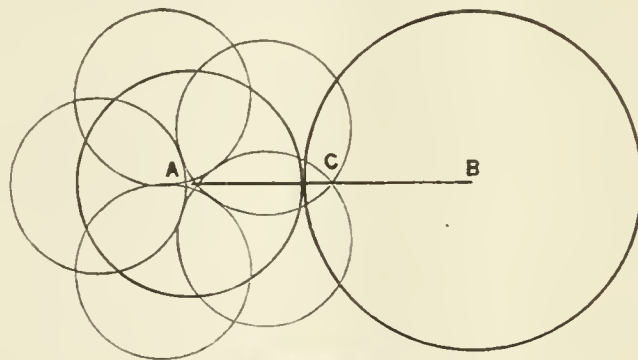

Diagram III.

the total illuminating power of that gas lamp is not represented by one of those circles, but by the sum of all of them—not taken individually, but by the entire surface inside of this circle. The divisibility of that light is represented by the large circle, including all these smaller circles. That is the illuminating power, and that intensity is to be multiplied by the area—which is the point I tried to make clear in my paper read last year before the American Association. Simply stated—that a great part of the value of a light depended upon its size, which latter feature determines its availability for illuminating space. The point that Mr. King made with regard to the water gas (having high intensity and equal areas with the coal gas flame) not diffusing its light so well, is not because the sizes of the flames are different, but, as I take it, may be traced to the difference in color. Suppose you take a water gas flame, with its higher heat, and, therefore, whiter light, and compare it with the flame from coal gas, with its lower temperature and greater proportion of yellow rays—each light to have the same area—the total product of the area into the intensity would be in favor of the whiter gas; but the diffusibility would not necessarily be the same, I think, on account of the difference in color. I think that this is a factor which should also be taken into consideration. We know that the yellow rays have greater diffusibility, and take up more room in the spectrum, than the lighter and whiter rays.

Mr. King—That is the point that I attempted to get at. I agree with Mr. Boardman in his statement of the case.

Mr. McMillin—Mr. Humphreys, Secretary of the American Association, is present, and if he heard Mr. Chollar's paper read we would be glad to to have him add something to the discussion.

Mr. Humphreys—I heard so little of the paper that I hardly feel like discussing it.

On motion of Mr. Jenkins the thanks of the Association were voted to Mr. Chollar.

Mr. McMillin—Although I am to be the reader of the next paper, I am nevertheless not its author. Most of you who attended the meeting of this Association, in Columbus, Ohio, last year will remember that the Messrs. Korting, of Germany, had a gas engine on exhibition at our gas works, and those who were interested in bringing that engine before your attention were moved thereto by the advice of Mr. Ernst Schinrock, who, although now a resident of Brussels, is I believe a naturalized American citizen. That gentleman has written a paper, and sent it here to our Secretary to be read at this meeting, its purport being to describe the system of retort furnaces now used in the gas works at Rome, Italy. The author claims to have sent on detailed drawings of the furnaces, but unfortunately these did not come to hand.

Mr. McMillin now read the following paper (it bears date of "Rome, Italy, April 28, 1887"), entitled

JOTTINGS FROM ROME.

Mr. President and Gentlemen of the Western Gas Association:—Last year I took great pleasure to place before you, at Columbus, Ohio, the first Korting gas engine ever shown on American soil, and to-day I find only enough time to tell you what I saw Sunday last, in the most renowned city of the past, and also of the future.

When I came to Rome I scarcely thought that this place might one day have an attraction for American gas engineers, who generally only visit England and Germany, in their hurried rambles through Europe, in trying to discover something new for introduction in their home works. The cities, towns and villages in our beautiful American country grow so fast that American gas engineers have had little time to think of devices; but how to save money by inventing simple and efficient, as well as cheap, furnaces for the distillation of coals being an important question, you will excuse this introduction. However, I will now come to the point that the gas works of Rome, and especially their Chief Engineer, Mr. Walter Jones, must be awarded the honor of having in actual operation the most efficient, simplest and cheapest furnaces, for they differ entirely from all other ovens, as will be seen by the drawings I hereby send.

The furnace is called a duplex furnace, and the plan is to get a deep fire in the high temperature furnace; to do away with the firebars; using two nostrils in the hearth floor; and a second fire, or low temperature furnace, caused by the hot scoria and small fuel which falls through the nostrils, the air being first let in through the lower firebars. The combustion is finished in the upper chamber, or high temperature furnace. The whole arrangement is so simple and inexpensive that it bids fair to do away with regenerator furnaces. The repairs are *nil*—no repairing being required, as the scoria itself repairs the furnace. The firebars being done away with, no clinkering is needed. In fact, the treatment is opposed to the existing system, as no force is required, and the brickwork, instead of being knocked about, is tenderly used.

From these it will be seen that no high chimneys are required; no deck foundations used; no stage floors are needed; no expensive repairs; no waste of materials; and no skilled laborers.

I asked the engineer and constructor of these furnaces if he could not hurriedly give me some particulars which I would communicate to the members of the Western Gas Association; and the following is a copy of the letter I received from that gentleman:

ROME, ITALY, April 25, 1887.

ERNST SCHINROCK, ESQ.: Dear Sir—A duplex furnace does not require more than 50 ordinary firebricks over and above the quantity used in constructing an ordinary furnace. Besides these we have 544 kilos. of special lumps, which compose the bottom of the temperature furnace, and last of all we have two extra doors and frames weighing 260 kilos. The cost, at Rome, of these materials is something less than \$25. This sum is saved in a very short period by the fact that no firebars are consumed, for the firebars in the low temperature furnace last the life of a furnace. The furnace outlives the duration of the retorts, because no clinkering is required. The repairs are *nil*.

The working results in 1886, in Rome, were as follows: The coal used was Newcastle, with 6 per cent. of Lancashire cannel. The average gas produced was 10,800 cubic feet. In the year, 49,485 tons of coal were

distilled, and 27,627 tons of good coke were sold to the contractor, who cleared the yards each 24 hours. This gives 55.82 per cent. of coke sold on coal distilled, and the 12.66 per cent. of fuel used under the retorts consisted of 7.50 per cent. of coke and 5.16 per cent. of breeze dust.

Besides the above, 2.52 per cent. of coke was used at the works for other than firing purposes.

The total quantity of coke made per ton of coal carbonized was 710 kilos. (0.7 of a ton), and is accounted for as follows: Sold to contractor, 55.82 per cent., or 1,250.3 lbs. per ton of coal carbonized. Fuel used for gas making, 7.50 per cent., rest dust breeze—12.66; for sundry purposes, 2.52 per cent.; total, 71 per cent. In fact, it may be stated as 58.3 per cent. sold and 12.66 per cent. used for fuel.

During the year 1885, 16 Liegel recuperative furnaces were used here, but have been abandoned, as the maintenance was too costly, and the results obtained not so good as with the duplex system.

There are now in working order in the Rome gas plant 84 duplex furnaces. Tar can be burnt in a liquid state in these furnaces, without any alteration to the latter, and with great economy. An opening of 50 centimeters (20 inches) is left at the middle of the slot, which consumes the whole of the tar-coke formed during its burning, which does away with the necessity for clinkering, for everything is consumed. We find that for each ton of tar consumed we make a saving of one ton of coke.

The profit in 1885, by the use of the duplex system, was £2,500 sterling, when only one-half of the ordinary furnaces had been altered. The profit from increased sale of coke during last year, as compared with 1884, was about £4,000 sterling.

Yours very truly,

WALTER R. JONES.

I can only add that the changing of old benches into the duplex ovens can be done within three days, at very trifling outlay for materials and labor. When in duty the saving of labor is great, and the manipulation of the furnace very simple, as compared with the old plan.

Whether it is advisable to introduce this duplex system into your American works I must leave to yourselves. It has already been adopted in several places in France and Italy, and Mr. Jones will gladly answer inquiries if further details are wanted. At the same time the Messrs. Jones, who superintend and manage the two Roman gas stations, invite their American brethren to pay them a friendly visit. A cordial reception awaits them, and they can then judge for themselves that Rome boasts gas works which can compare in internal improvements with any in the world of a similar size.

I hope, Mr. President and gentlemen, your time has not been taken up longer than 15 minutes, and that the intrusion upon your valuable hours will not have been without benefit to the members.

Discussion.

Mr. McMillin—It is unfortunate we have not received the drawings mentioned. It seems a remarkable statement that with an expenditure of about 50 bricks over those in an ordinary furnace, results can be obtained which enable them to sell over 50 per cent. of the weight of the coal in coke. That is about as much coke as we make when we use Ohio coal. I feel it is difficult for the Association to comprehend the construction of the furnace without the drawings. I am myself unable to see where any great benefit can be derived from this style of furnace, by passing the gas in through the scoria and small coke that falls down, the air being admitted at that point, and afterwards passed up through the main body of the coke. Unless that upper story of the furnace gets air from some other source, or there is secondary air introduced above the coke (of which he does not speak), I could hardly see how it would be possible for such results to be obtained. He has probably left that statement out. He could form carbonic acid in the lower furnace, and decompose it in the second chamber, and burn the carbonic oxide in the neighborhood of the retorts. That is possible. However, there are always two sides to these questions; and after spending a Sunday in an examination of a system of that kind, he might not become thoroughly competent to judge of its merits. The result, however, of the sale of coke by the year is certainly marvellous.

Mr. Lindsley—Has Mr. McMillin any idea as to the depth of the upper furnace?

Mr. McMillin—I have no idea of the depth of the upper furnace, but from the fact that it does not have any basement (for he speaks of that) and that it only takes fifty extra brick, we may conclude that it cannot be very deep unless the bricks are on end.

On motion of Mr. Lansden, the thanks of the Association were voted to Mr. Schinrock.

Secretary Littleton here read a paper, forwarded by its author (Mr. J. W. Dunbar, of New Albany, Ind.), who was unable to be present. The paper bore the title—

FURNISHING GAS WITHOUT A HOLDER,

and is as follows :

Having for a period of one week furnished gas to the citizens of New Albany without using a holder, or direct from retorts to the street mains, it may be of interest to those who may at some time be similarly situated to know the experience of one who so furnished it, and also the cause that occasioned the practice.

Our holder has a capacity of 60,000 cubic feet, our maximum daily sendout being 75,000 cubic feet, the minimum being 21,000 cubic feet. It was during the latter period of make that gas was furnished as above stated.

The inlet and outlet pipes to holder are 10 inches in diameter, being (in their upright position inside of holder) 2 feet apart. It was because first one and then the other admitted water through the lead joints on inside of holder, together with the leaky condition of the rivets and the seams of the iron, which leakage at one time amounted to as much as 20 per cent. of the gas produced, that necessitated this undertaking. The outlet pipe had been abandoned for several months, while the inlet one was admitting water to an extent that made the situation very alarming, so it was determined, as we have only one holder, to abandon it to repair leaks to stand-pipes, and to see what could be accomplished in the way of preventing the enormous leakage.

We have at our works 5 benches of threes, 4 of which were fired preparatory to commencing operations. Sunday was the day which I deemed best to commence operations, on account of the small amount of gas required on that day, as well as on account of it being the commencement of the full phase of the moon; but our President had no faith in the success of any undertaking commenced on the Sabbath, so it was deferred until the next day. The first thing to do at holder was to get 500,000 gallons of water out of the tank. On account of very low adjacent ground I was able, with two 3-inch siphons, to get out considerably over one-half of the water; a city steam fire engine was used to pump out the remainder, which operation required until up to midnight of Monday. Previous to siphoning out the water, however, the tank had been filled full of water, so as to leave as little gas in holder as possible when it was down, and the man-heads were first removed, care being taken, for a short time, that no fire was brought in the immediate vicinity. On Tuesday morning, six hours after tank was emptied, we were able to descend upon inside of holder—without experiencing any bad effects from foul air—to examine stand-pipes, which had been previously filled with water, in order that we might the more readily find the leaks. Fortunately we had no trouble in this. The stand-pipes are about 2 feet apart. Two lengths had been required to reach proper height, necessitating a lead joint, on both the inlet and outlet pipe, about 7 feet from the top. The leakage was found to be in there. The outlet pipe could be made to vibrate as much as 5, and the inlet pipe as much as 3 inches. All we found necessary was to thoroughly caulk the joints, which stopped the leakage, and we have had no like difficulty since.

In this connection the question as to what caused the leakage naturally arises. I can only account for it by supposing that the water, during an unusually cold spell, congealed upon inside of holder, and the expansive action of the ice caused the pipes to become separated or drawn further apart—for it was during one of the cold spells that the leakage commenced. The following summer the leakage was no worse than in the winter spoken of, but in the following winter, during extreme cold weather, the outlet pipe had to be abandoned on account of increased leakage, while the inlet was called on to perform the duty of the outlet in addition to its own work. Our holder is some distance from the works, so that (having no steam) it is impossible in winter to keep the tank water from freezing around the holder, thus necessitating the breakage and removal of the ice by means of manual labor. The average temperature at which our gas was registered during these extreme cold spells reached the low mark of 38° F., which, when subjected to further exposure, while in holder, with the atmospheric temperature ranging from zero to 15° below, the gas no doubt was below the freezing point. If anyone can account for this leakage by any other theory I shall be glad to have his opinion.

Having repaired the stand-pipes we next turned our attention to the devising of means to prevent the enormous leakage. In some places we found the holder seams were sufficiently parted to admit of the insertion of an ordinary knife blade between them. These we filled with a putty composed of litharge, red and white lead, worked with glycerine. That mixture hardens shortly after having been used. We found that many of the rivets had not been driven up as tight as they should have been, so these rivets on the inside, together with the seams, were given a coat of the mixture spoken of, care being exercised to thoroughly work the

paint into all the cracks and crevices. When this was completed the tank was filled with water and the gas admitted to holder, the first 8,000 to 10,000 cubic feet being permitted to escape. I may say that the painting of the rivets, together with the filling up of the cracks in seams, as above described, caused our holder to become a perfectly tight one. In fact all the labor now required on it is to paint it twice a year, which operation takes us but a few days, whereas formerly it required the expenditure of about three weeks of work at least twice each year. Previous to our successful attempt we tried everything suggested to prevent leakage, and while the leaks would be temporarily checked, yet, and in very short time, the holder would leak as badly as before. My opinion is that a leaking holder cannot be made tight by work done upon it from the outside, chiefly for the reason that the paint cannot be so easily and thoroughly applied. Again, after it is externally applied there are many things that act to remove it.

In furnishing gas without a holder we experienced no difficulties except during the first night, and these only lasted for a short time. In winter we give 1.9 inches and in summer 1.2 inches pressure, the latter amount being all that is required in that season.

When night of the first day approached we began charging our retorts, and ran the pressure up to 3 inches, at which point I determined to keep it; but it soon decreased, and with such rapidity that we could not check its downward course. It went as low as five-tenths, at which figure it remained only for a short time, or until the remaining retorts were charged, which action brought up the pressure to over 2 inches. Shortly thereafter our washer choked on us, and the pressure was again lowered to five-tenths. To remedy this we turned on a by-pass, and the pressure was once more raised to 2 inches. The next night I commenced charging the retorts earlier, and ran up the pressure to 5 inches before I stopped charging. When it commenced to go down we again charged more retorts, until finally all were charged. The coal was then permitted to remain in retorts until the pressure got down to 2 inches, when the retorts that were first charged were drawn and recharged; and so it continued through the night. No street lamps were lighted, except for a few hours on one night. Not much work was required, except for a few hours between 7 and 10 P.M. The quantity of gas made per hour was about 8,000 cubic feet. The weight of coal charged was about 325 pounds to the retort.

On the evening that the street lamps (475 in number) were lighted, our make was about 11,000 cubic feet per hour. We were able with this send-out to maintain 1.3 inches pressure. During the day we examined every stand-pipe, so as to have it clear at night, and also examined thoroughly the washer—in fact every pipe which we thought would be liable to choke up. Everything worked satisfactorily. No complaints were heard from the consumers. The illuminating quality of the gas was above the ordinary candle power, which, with an increase of pressure, caused the gas to be satisfactory to all who consumed it.

[A vote of thanks was passed to the author, owing to whose absence the paper was not discussed.]

ELECTION OF OFFICERS.

Mr. Jenkins from the Committee on Nomination of Officers presented the following report :

Gentlemen :—Your Committee on Nomination of Officers for the ensuing year beg leave to report as follows :

President—Emerson McMillin, Columbus, Ohio.

First Vice-President—Geo. G. Ramsdell, Vincennes, Ind.

Second Vice-President—E. J. King, Jacksonville, Ills.

Secretary and Treasurer—A. W. Littleton, Quincy, Ills.

Board of Directors—A. E. Boardman, Macon, Ga.; Geo. H. Wells, Nashville, Tenn.; A. T. Averill, Cedar Rapids, Iowa; R. C. Johnston, Lawrence, Kas.; Eugene Printz, Zanesville, Ohio; W. H. Odiorne, Springfield, Ills.; Frederic Egner, St. Louis, Mo.; C. H. Raynor, Adrian, Mich.; E. G. Cowdery, Milwaukee, Wis.

[Signed by the Committee.]

Mr. McMillin—Before action is taken on the report I suppose that remarks are in order. I know that every gentleman here realizes the fact that I appreciate the nomination to the Presidency of this Association, and I am probably as ambitious as anyone here; but there is a limit to one's ability to attend to these outside matters. I have just retired from the Presidency of the Ohio Association, and would feel greatly relieved to come in here at a later period—say ten years from now. If Mr. Ramsdell were here he would doubtless make the same sort of speech; but in his absence we could play a very nice practical joke on him by electing him President. In all seriousness I ask the Association to substitute Mr. Ramsdell's name for mine. The Presidency of these Associations does require a great deal of attention, and I would be glad to have

at least a few years vacation after retiring from the Presidency of one Association before I accepted the Presidency of another.

Mr. Lansden—I move that the report of the Committee be accepted, and that Mr. Jenkins be instructed to cast the vote of the Association in accordance with the recommendation of the Committee.

[The motion was carried. Mr. Jenkins announced the result of the ballot, and the President declared that the gentlemen recommended by the Nominating Committee had been elected to serve as officers of the Association during the ensuing year.]

RESPONSE OF THE PRESIDENT-ELECT.

Mr. Howard—We would like now to hear again from President-elect McMillin.

Mr. McMillin—I suppose it would hardly be in order to say that I sincerely thank you for the election; but if there is anything in the world that would compensate me for the disappointment in being elected, it is found in the fact that I am associated with the gentlemen named in that list—with such men as Ramsdell, King and Littleton, to make no individual mention of the Board of Directors, who are entirely too numerous for me to remember their names. I will doubtless be able to shift a great deal of responsibility and labor from my own shoulders to theirs; and that idea having occurred to me since I made my last speech, I do now sincerely thank you for the election. (Applause.)

REPORT OF COMMITTEE ON PLACE OF MEETING.

The President—We are ready for the report of the Committee authorized to select a place wherein to hold the next meeting.

Mr. Cosgrove reported that the Committee had decided to recommend Cincinnati, Ohio.

Mr. Lansden—I thought at one time it was well understood that the Western Association should hold one meeting at St. Louis, Mo., next at Chicago, Ills., and then go to Cincinnati, O., returning to St. Louis, on to Chicago again, and then to Indianapolis, Ind. We have now twice visited the extreme border, but last year the meeting was held at Columbus, Ohio, while now we are in St. Louis. This is not the heart of our district; but Chicago comes nearer than Cincinnati to being the most convenient for the largest number of our members. If we meet on the east side too often I do not think we will have the same success. Cincinnati is a very nice place to go to, and would properly come in, in its course, the following year.

Mr. Egner—I am very sorry to see that Mr. Lansden has lost all local patriotism, and I say it as an adopted St. Louis citizen. He deliberately proposes to adjourn at St. Louis to meet at Chicago. I hope, rather than do that, he will stick to the report of the Committee and go to Cincinnati. I do not wish to say anything about Chicago—there are some nice men there; but don't let us go from St. Louis to Chicago. (Laughter.)

Mr. Lansden—I am certainly interested in the success of this Association, and come to think of it, I believe that Brother Egner has met with us only once before the present time. I have been with the Association since it started, and think the interest of the Association demands that we should meet at times in the center of our territory, or at points where we can most conveniently meet. I hardly think it is to the interest of the Association to assemble in two successive years on the extreme eastern border of our territory.

Mr. McMillin—It would certainly afford me great pleasure to have you come to Ohio, for that seems to be the place for holding good meetings; but I am a little inclined to side with Lansden, for once in my life. The Ohio Association holds its annual meeting in March, and as almost all of the Ohio men now belong to that Association the attendance is very good. Of course, when you leave St. Louis and Chicago, to go over into Ohio, you must miss some of the far Western men, and you expect to make that loss up by securing the attendance of those further East, in order to have the usual number present at the meeting. As this Association holds its meeting so soon after that of the Ohio Association—the one being in March, and the other in May—I doubt very much if the attendance from the Ohio members would be large enough to compensate for what we would lose in attendance from the far West. I rather hoped that our next meeting would be in Louisville, Ky., and that we should pay a little deference to our Southern members—they are getting to be quite a factor in this Association; but the Committee, doubtless, have good reasons for suggesting Cincinnati. I want to offer the one suggestion that as the Ohio Association meeting takes place within 60 days of the meeting of the Western Association, it would very seriously interfere with the attendance of the Ohio members, or to such an extent that you could hardly make up in Ohio what you lose from cities so far west that the members would not feel able to come.

Mr. Jenkins—Perhaps the Committee have some reason for making this change.

Mr. Cosgrove—We had no personal preference for the location of the next meeting, but aimed to do that which seemed to be for the greatest good of the Association. Remembering that three years ago we met in St. Louis, two years ago in Chicago, and last year at Columbus—taking it away then from Cincinnati—we thought it best to recommend that the next meeting should be in Cincinnati. If we confine ourselves to this radius, alternating between the three large cities, Cincinnati would certainly be entitled to it next year. I think we have had but one meeting of the Association in Cincinnati. There was a preference expressed in a quiet way in behalf of Louisville. I felt very favorably towards having it there; but as no overtures (at least that I have heard of) from Louisville were put forward by the gas men of that city, we did not feel like presuming on her people. I shall be satisfied, as one of the Committee, to have the next meeting at Louisville, if such is the sense of the Association. The Committee are not at all arbitrary in the matter.

Mr. Barret—Speaking for the gas men of my city, I should be most happy to have the Association meet at Louisville. I did not deem it necessary to extend a formal invitation, supposing you would take it for granted that we would be glad to have you visit us. That invitation is now formally extended to you, is frankly given, and I hope it will be accepted.

Mr. King—This discussion seems to come up at almost every session of the Association, and we have always decided to take the regular course. The mapping out of this triangle of cities was proposed and agreed to for the reason that it gave the members of the different sections an opportunity once in three years of having a meeting near their own homes. If that be the idea, and this time we change our course and go to Cincinnati, because we did not go to Cincinnati last year, then next year we would probably go to Chicago, and the year after come back to St. Louis, thus holding the meeting here at an interval of only two years, and hence we would inflict ourselves upon the St. Louis people again in two years instead of three. It seems to me that in due time we will get around to Cincinnati and Louisville—I would myself like to go to Louisville; but it seems to me better to follow the regular course that we have heretofore adopted.

Mr. Lansden—I only desire that which is for the best interest of the Association. The success of our Society depends, to a great extent, upon the number of members who attend its meetings. I think if we have meetings at the extreme borders of our territory we will not be able to secure the attendance of as many members as we would if we followed the course heretofore pursued.

The President—Mr. Lansden, if you want to change the plan, why not make a motion to that effect.

Mr. Lansden—I move that the Association establish a permanent system of meeting; that they meet on the South one year, on the North one year, and on the East—either at Cincinnati, Indianapolis or Louisville—the third year; at St. Louis on the fourth year; on the fifth at Chicago; and then revert to the eastern cities again.

The President—To make that a permanent arrangement the resolution would have to be put in writing and laid over until the next year. All that you can do now is to make a motion as to where we shall meet next year. If you want to make a permanent arrangement you must make an amendment to the by-laws.

Mr. Howard—If our success in the past is any criterion I would call attention to the fact that the meeting at which we had the largest attendance, and the most satisfactory in other respects as well, was the one that was held in Cincinnati.

Mr. Lansden—I think there is a good deal in the suggestion made by Mr. McMillin that they are surfeited with gas conventions in Cincinnati; and it may not be well for us to meet in Cincinnati so soon after the meeting of the Ohio Association.

The President—But the Ohio Association does not meet in Cincinnati next time; the Convention for 1888 will assemble in Sandusky. There is only one city mentioned in the resolution. If no amendment is proposed I will put the question on that resolution.

Mr. Lansden—I move to amend by substituting Chicago for Cincinnati.

The amendment of Mr. Lansden was agreed to, and the Association voted to hold its next annual meeting at Chicago.

ELECTION OF HONORARY MEMBERS.

Mr. McMillin—We have here with us to-day the gentleman who occupies the position of Secretary of the American Gas Light Association. He is skilled in the profession which we follow, and is an honored member of the fraternity. He is a gentleman whom you will all be glad to know and to associate with. I nominate Mr. C. J. R. Humphreys, of Lawrence, Mass., the Secretary of the American Gas Light Association, for election to Honorary Membership in this Association.

The nomination was seconded by Mr. Howard, and the Secretary was instructed to cast the ballot of the Association, in accordance with the proposition made by Mr. McMillin. The Secretary having carried out the instructions, the President formally welcomed Mr. Humphreys to Honorary Membership. Mr. Humphreys made the following response:

I am greatly surprised at this action. I had no idea of being so honored. I wish to express to you, one and all, my sincere thanks for the honor, and my assurance that I fully appreciate an election to such membership in so energetic an Association.

Mr. Lansden—The New England Association saw fit, at its last meeting, to honor one of the members of the gas fraternity who, although now bearing manfully and patiently a severe affliction, is nevertheless now as active in mind in following out the complexities of our business as he was energetic in personal action when in possession of robust health. I refer to Mr. Geo. A. McIlhenny [applause] of Washington, D. C.; and I move that he be elected to Honorary Membership in this Association.

The nomination being ratified, the Secretary, by request, cast the ballot of the Association in favor of Mr. McIlhenny's election. The result, when announced by President Fullagar, was received with cheers.

Mr. Howard—I desire to place in nomination for election to Honorary Membership in this Association a gentleman who is well known to you all, and I think everyone will agree that he merits the elevation which such action on your part will award him. He was Secretary of the American Association, and he served its best interests faithfully and well. He has been a frequent attendant at the meetings of this Association, and his visits here have been appreciated by us. I now move that Capt. W. Henry White, of New York city, be elected to Honorary Membership in the Western Association.

The motion, seconded by Mr. King, was agreed to, and the Secretary cast an affirmative ballot. Capt. White having been declared elected an Honorary Member, was formally introduced to the members, and responded to the compliment in his usual genial and happy manner.

AN AMENDMENT TO THE BY-LAWS.

Mr. McMillin—In looking over the by-laws I noticed that the portion governing the election of Honorary members is decidedly obscure; and in order to make such practice plain in the future I herewith submit the following amendment:

HONORARY MEMBERS.—Section —. The Board of Directors may in their discretion recommend to the Association, for election to Honorary Membership, persons who may be eminent for their skill, or mental acquirements, in the manufacture of gas, or in gas engineering; and, when so recommended, the name or names so proposed shall be voted on, in the usual manner for election to active membership.

Honorary members shall not be required to pay dues.

[Under the rules the McMillin amendment goes over, to be decided at the next annual meeting.]

LETTER FROM MR. SPENCER.

The Secretary here read the following letter, from Mr. R. Spencer, of Burlington, Iowa:

To A. W. LITTLETON, Secretary Western Gas Association:—You ask me to contribute a paper for use at the May meeting of our Association, but I must not attempt it. I cannot edify you, therefore I will not bore you with commonplaces from my poor experiences. I am superannuated; absolutely shelved; practically out of the business. Despite that state of the case, I yet am desirous to acknowledge my indebtedness to and appreciation of the great value of the Western Gas Association, hence I have thought it not improper to show my good-will to you in a more modest and less pretentious way.

I regret that an engagement in New York will not permit me to be with you on the occasion referred to, to greet you all, as of yore, with joyousness—as no other experiences of my past life have given me more real pleasure. Aside, also, from the pleasure of meeting my brethren on these interesting occasions, I am impressed with the inestimable value of this and kindred Associations to their members professionally; and, through them, to the companies they represent, to the communities in which these companies are located, and to the whole people. Organized as we are, and meeting from year to year to discuss the best methods of construction, the best adaptation of means to ends, in distribution and administration, without antagonisms, without conflicting interests to mar the harmony of our meetings, with only a spirit of emulation to stimulate us all to our best endeavors for the advancement of the common cause, the results of our combined efforts cannot help being in the interest not only of the gas fraternity, but, through it, to society generally.

I cannot forbear in this connection to mention how much, in my humble judgment, this Association is indebted for its rapid growth, its interesting history, and its great usefulness, to the manly dignity, the wise councils, the uniform courtesy and forbearance of its first President, Mr. J. O. King,* the mention of whose name brings only pleasurable emotions to every member; whose every joyous experience in his declining years will give pleasure, and whose every sorrow will elicit the heart-felt sympathy of all.

As I write, the figure of our second President, Mr. Thomas Butterworth, arises before me in that robust and vigorous attitude so characteristic of him. Cut down in his prime, in the midst of his active usefulness—to our weak and finite perception, all too soon. Yet, realizing our shortsightedness, we must conclude that the Infinite Father had a higher sphere of usefulness for him in the Eternal City, illumined not with our poor product, but with radiance from the glory of the Divine Humanity. We cannot but mourn his loss. We will cherish his memory, and try to imitate his virtues.

Starting, as this Association did, under the wise leadership of the above-named presiding officers, and continuing under that of men happily chosen with special reference to their fitness for leadership, its affairs have always been conducted with signal ability; its meetings have been presided over with that dignity which commands respect and consideration; and its discussions have been conducted with animation, giving growing evidence of vigorous thought that tended to root out the unsound dogmatism of the past, arousing a determination to discover the truth and follow it whithersoever it might lead, regardless of consequences to old maxims and pet theories.

This hastily written and very imperfect review would not only be incomplete, but great injustice would be done, did I omit to mention the worthy Secretary of this Association, to whose untiring industry and persistent effort so much of its success is due. Ever present, as it were, to each member with written letters, with printed circulars, urging them to vigorous action, in season and out of season (if that were possible), inspiring them to more persistent effort to build up and strengthen our Association for more active work and a wider sphere of usefulness.

As an humble member, I am proud of this Association. Proud of its past history; of its great achievements. And my hope, as well as my confident expectation, is that its future will not only realize what its past history and its present prosperous condition promise, but that its sphere of usefulness will be greatly enlarged, and its efficiency much increased, to the end that its members may become more and more indispensable in their sphere of life to the communities in which their lots are cast.

(To be continued.)

A Glance at Some Past Projects for the Manufacture of Oil Gas.

Mr. N. H. Humphrys, F.C.S., etc., contributed the following interesting communication to a recent issue of the *London Journal*. The author wrote:

It is scarcely necessary to mention that the idea of gasifying hydrocarbon fluids is in no sense novel, as it dates back to the time when coal gas was first introduced. On account of the large yield of high quality gas that can be obtained from a suitable kind of fluid, it has always been a favorite with inventors in the "household gas works" line, who have aimed at enabling every householder to be his own gas maker, so that he may supply himself with as much gas as he requires, by means of a small retort attached to the kitchen range. It is not too much to say, perhaps, that gas making on the "household" scale can be carried on more successfully by means of a light oil than with coal. Looking back over the numerous ideas that have been proposed, some of which have been put into practice on the small scale, to a greater or less extent, it will be seen that many of them are extremely ingenious, and show a fair state of knowledge as to the conditions necessary to be observed. In many cases the apparatus is intimately linked with that used for coal and other solid materials. The plan patented by Hillary in 1846 may be cited as an example. His idea was to place the condenser (which was the common vertical arrangement) at an elevation above the retort, so that the condensed liquid could be returned into it. The retort was of the ordinary horizontal kind. In place of the ascension-pipe, however, there were three pipes; and these, instead of terminating inside the mouthpiece, curved at right angles, and extended nearly to the back of the retort—being situated close to the interior top surface. The retort was made sufficiently large in section to contain these pipes, and leave the usual space for coal, etc., besides. The center pipe formed the outlet for the gas; and the side ones the oil or tar pipes, which returned the

*Mr. Spencer's letter was written about a week prior to the decease of Ex-President King.

fluid from the condenser into the retort. Evidently, what is aimed at here is that the liquids on traveling through the hot pipes should be gasified. The vapors, escaping into the retort, would there mix with the gases evolved from the solid fuel, and pass off with them along the center pipe, which is maintained at the same temperature as the retort; being thoroughly mixed therewith, and, to use the popular expression, "fixed" by contact with the red-hot surface. This apparatus is mentioned because it combines nearly all the features of oil gas apparatus at present manufactured. The main idea seems to be that there should be no liquid residuals; the whole being converted into gas, or else deposited in the retort.

There is one remarkable difference in practical detail, as compared with the method of distilling coal for the production of gas, that is universally followed by oil gas makers. The rule in ordinary gas works is to get the gas out of the retort as rapidly as possible, so that it shall not come into contact with the red-hot surfaces, the interior of the retort, and the incandescent coke, more than can be helped. But in oil gas apparatus the gas, after being formed, is designedly brought into contact with red-hot surfaces, in order to "fix" it. In the original patent of Taylor, taken out in the year 1815, the arrangement resembles two tube retorts; the oil being gasified in the first, and the gas being fixed in the second. With the same object in view, changes have been rung by subsequent patentees on the use of two or perhaps more separate retorts, either empty or charged with materials calculated to assist the "fixing" process; on single retorts having tubes inside, or divided by diaphragms or partitions in such a manner as to afford the nascent gases a long extent of travel; or retorts U-shaped in longitudinal section; and on combinations of tube retorts. Of these, the twin retort patented by Laming and Evans in 1850 may be instanced. This consisted of two horizontal retorts joined together at the back, having a mouthpiece there common to both, and a separate mouthpiece to each at the front. This arrangement could be made in one piece, if desirable, and was so placed that one limb came exactly above the other. The ascension-pipe was situated on the lower mouthpiece, and both retorts could be charged and worked with any solid gas-making material. On the upper side of the top retort, toward the front, but still a sufficient distance therefrom to be situated at the hottest part of the retort, an inverted funnel-shaped attachment rises, extending out through the top of the setting, and closed with a suitable lid. A wrought iron tube, with a syphon seal and funnel, is screwed into this lid; so that oil, tar, or any suitable fluid may be dropped in regulated quantity into the heated retort. The gas generated by this means had to travel along to the back of the upper retort, then descend to the lower one, and flow through it to the mouthpiece at the front. In effect it was simply another and apparently a more practicable way of carrying out the ideas which animated Hillary and his predecessors. The oil gas, after generation, was caused to pass over a considerable extent of heated surface; and facility was also given for enabling it to mix with inferior gas from cheap coal or other material.

It will be observed that both the inventions above named afford ready access to all parts for the removal of deposited carbon. The Laming and Evans apparatus especially has no small tubes or parts where such would be likely to give annoyance, and shows signs of having been specially designed with this point in view. Judging from many of the forms of apparatus which have been proposed, considerable trouble has been experienced from deposits of solid carbon, and arrangements have been made for its removal. When the liquids are used in connection with solid material, the removal of the coke or debris left from the latter also brings with it the deposited carbon. In apparatus for liquids solely, many different expedients, some of an extremely ingenious character, have been suggested. Taylor, in 1815, placed his tube retorts at an inclination from the horizontal, and allowed the liquid to enter at the higher end; so that any portions escaping gasification for the time should trickle downwards, and so come in contact with fresh areas of red-hot surface. This idea has been repeated over and over again in one form and another. Many mechanical contrivances have also been introduced. One inventor uses an upright retort, and fills it with suspended chains, which are caused to "clank" one against the other by a simple mechanical device that can be actuated from the exterior; thus dislodging any deposited carbon and dropping it to the bottom, from whence it can be raked out by a side door. Mr. Goldsworthy Gurney, in 1862, adapted an ingenious arrangement to a round horizontal retort. A steel rod, working in a stuffing-box at one end, carried a half round hoe or scraper, fitting loosely to half the section of the interior of the retort, and also a "fin" or stirrer, consisting of a piece of steel, attached to the end of the rod at right angles, opposite to the hoe. On the outside of the setting, under the mouthpiece, was a recess or chamber, into which any accumulated matter could be raked. By this means any carbonaceous deposit

could be removed from the retort whilst in action. Messrs. Porter and Lane also proposed to adapt their well-known "screw retort" to the same purpose.

Others have sought to utilize the excess of carbon by converting it into carbonic oxide, in which case it would go to increase the bulk of the gas produced, though of course acting as a diluent. This was effected by introducing oxygen, either in the form of air or steam, into the retort. The objection to the admission of air is the loading of the gas with a large quantity of inert nitrogen. For the gasification of 6 lbs. of carbon, 8 lbs. of oxygen are required, or, say, 40 lbs. of air; from which it appears that, for the effective treatment of 1 lb. of carbon, something like 90 cubic feet of air, including nearly 70 cubic feet of nitrogen, will be needed. If steam is used the nitrogen is dispensed with; the result *in theory* being the formation of hydrogen and carbonic oxide gases, both of which are useful as heat producers. One pound of carbon should require $1\frac{1}{2}$ lbs. of steam, and should form therewith $2\frac{1}{2}$ lbs. carbonic oxide ($31\frac{1}{2}$ cubic feet) and $\frac{1}{4}$ lb. of hydrogen ($31\frac{1}{2}$ cubic feet). So the total bulk of diluent gas produced will be considerably less than that resulting from the use of air; and it will also be of more suitable quality, as the hydrogen assists in producing heat.

The difficulties in the practical application of this plan are numerous; but two may be specially named. These are: The poisonous nature of carbonic oxide; and the formation of a considerable quantity of carbonic acid, which deteriorates the value of the gas, and is costly to remove. Whatever the advocates of water gas may say, there is little question as to the danger and risk connected with the supply of a gas containing a large percentage of carbonic oxide. It has been proved that this gas is an active poison—about 100 times more injurious to animal life than carbonic acid. Possibly very light fluids, having a specific gravity of not more than 0.7, might be entirely converted into gas with the aid of steam. For example, a sample of commercial "benzoline" experimented upon by the writer yielded 107.5 cubic feet of gas per gallon, no tar, and only 1,250 grains of carbonaceous soot. The latter could be converted into gas by the addition of 1,875 grains of steam; the resulting product being about six cubic feet of carbonic oxide, and a corresponding quantity of hydrogen. This, added to the 107.5 cubic feet, would not produce too large a proportion of the poisonous element, nor would it dilute the gas to an undesirable extent. But it would never do, in practice, to be dependent upon an artificial product for a supply of gas-making material; so that this must not be taken as an indication of what could be done in everyday operations. The gas engineer would have to be prepared to deal with liquids yielding 20, 30, and perhaps nearly 40 per cent. of carbon and pitchy matters. Another difficulty is that a considerable extent of contact with red-hot surfaces is necessary for the formation of carbonic oxide; and this will have an injurious effect upon the light-yielding hydrocarbons, not only impoverishing the gas, but leaving as much carbon behind as is taken up as carbonic oxide. So far as existing or hitherto proposed forms of apparatus are concerned, the gasification of the carbon by the introduction of oxygen, either through the medium of steam or air, is impracticable. By the time the carbon was gasified the light-giving power of the gas would be reduced to a very low quality. This objection does not apply in the case of heating gas; and therefore, where the production of a fuel only is desired, it is quite possible to completely gasify the carbon.

If we look in the direction of the addition of a hydrogenous gas of poor quality to the oil gas, which could be done by means of either of the appliances already described, the retort being charged with the inferior coal, wood, or whatever the material may be, the prospect is more hopeful. It is known that the admixture of hydrogen with a rich gas hinders the decomposition, and consequent deposition of carbon and deterioration of quality, which results from its exposure to contact with red-hot surfaces. If olefiant gas is caused to pass through a tube raised to high temperature it is converted into marsh gas, with deposition of solid carbon; but if the olefiant gas be first mixed with an equivalent bulk of pure hydrogen, this action becomes limited to a great extent. If the experiment is repeated under the same conditions as before, only a little carbon will be deposited, and the illuminating value of the mixture will not suffer much. Consequently, while admixture with a poor quality of coal gas, or a gas similar in nature, will not lead to the reabsorption or gasification of carbon already deposited, it is evident it will greatly hinder the formation of such deposits.

But it has repeatedly been shown that the mere retention of carbon in the gas is not all that is to be looked for, in the securing of the best results as regards illuminating value. Many years ago there was a notion prevalent to the effect that the proportion of carbon in the gas had some relation to the illuminating value of the same; but we now know that this is not necessarily the case. It has been shown, for example, that

benzene (C_6H_6) is a better illuminating agent than ethylene (C_2H_4), to an extent greater than that proportioned to the larger quantity of carbon present in the former. So it is essential, in solving the problem of how to extract the best possible illuminating value out of any substance, not only to consider how to retain as much carbon as possible in the gas, but also how to retain it in the most suitable form. Gas engineers have found, from practical experience, that the best results are obtained from coal by the use of high heats, which secure rapid generation of gas, coupled with the removal of the gas as fast as it is made. It remains to be shown whether this point is confined to coal only, or whether it is also true as regards fluid hydrocarbons. It is directly opposed to the "fixing" process, or the conducting of the gas through a second retort, which is so dear to the hearts of oil gas inventors. For it is evident that this plan, applied to coal gas, would not only result in a depreciation of illuminating value to an extent proportioned to the amount of carbon deposited, but there would also be a loss in a greater degree.

Tube Cutting and Screwing Machine.

At the Manchester Exhibition, Messrs. John Cowley & Son (of No. 6 Clarendon street, Hyde, England) displayed a large assortment of hand and machine screwing devices, capable of screwing bolts and nuts up to $1\frac{1}{2}$ in. in diameter at one operation. They also exhibited a new design of machine for screwing gas and steam pipes up to 4 in. in diameter at one operation, an illustration of which accompanies this notice.

A slide rest and cutter is provided on the revolving die stock for cutting off nipples and various lengths of pipes. The cutter or tool used is of peculiar construction, in that it is composed of three pieces, the center one being a plain square-nosed parting tool, and the two side ones pointed and beveled. When plain pipe cutting is required, the center one only is used, by being made to project more prominently than the others; but when nipples are required the two side tools are used as well as the center one. This leaves the ends of the nipples beveled off without damaging the threads—a result not obtained by ordinary machines. The end of the slide rest screw is provided with a wheel on the rim of which there are projecting arms, so that at every revolution of the cutter one of these arms catches on a stop and partially turns the feed screw and puts on the cut.

The screwing dies have a large number of cutting edges in order to keep thin pipes perfectly cylindrical when being screwed. This arrangement secures a tighter joint and prevents the longitudinal cracking which so often occurs with dies having only four cutting edges, for when pressure is applied to such dies they press the pipe out of shape, and consequently subject it to a constant bending as they revolve; this very soon cracks and destroys thin pipes, especially when they are not of the best material, such as gas pipes.

The cut is put upon the dies by means of a spiral cam plate, which is fitted with an index. By this device the dies can be set to screw any standard size at one operation. The vice jaws for holding the work are tightened by a screw which is fitted with a worm and wheel in order to get a firm grip on the work. A complete set of dies and vice jaws are provided for all sizes of pipes. Many of the large steam and gas pipes used in the Exhibition were screwed by this machine in its present position.

The Electric Light at the Suez Canal.

Engineering says that the Cairo correspondent of a Glasgow paper has recently been engaged in making an inquiry regarding the use of the electric light in the Suez Canal. He says that the use of the electric light for navigating the Suez Canal by night is feasible as regards mail steamers and men-of-war, though whether it will remain in use permanently is open to doubt. As regards ordinary steamers, officers and crews of which are not so numerous and efficient as those of the men-of-war and mail vessels, the use of the electric light is likely to prove a delusion and a snare. Going southward, in the full glare of the Egyptian desert, facing the sun, unfits him much at nightfall. If at that time he exchanges the blazing sun for the dazzling electric light, by the time the vessel gets out of the Suez Canal the dazed and jaded skipper cannot be in a fit condition to take his ship the next night through

reefs which abound in the Gulf of Suez, and the endeavor to avoid which calls for his utmost vigilance, care, and skill. The writer goes on to say that after a few outward-bound ships have knocked their bottoms out in that part of the world, the underwriters will awake to the fact that the electric light in the Canal is to a great extent to blame for those catastrophes. Homeward-bound commanders, after running the gauntlet of the Red Sea shoals and the risks of the Gulf of Suez, find the Suez Canal a sufficiently tiresome business by day; but to do it by night in addition, by the aid of the electric light, means that by the time they reach Port Said every man on board will have been worked to death.

It is, he further says, hard enough in the daytime to get vessels safely by the dredgers and hoppers in the canal, but at night, when the dredgers chiefly work, the difficulty will be enormously increased, and particularly as extension works are supposed to be now going on.

No effort has been hitherto spared by the Canal Company to make the use of the electric light a success, so that as yet there has been an immunity from accident, which is regarded as being somewhat surprising. But when, in consequence of the difficulty of judging distances by means of the electric light, another dredger is capsized across the canal, or some ship is sunk in collision, causing another fortnight's delay, shipowners will perhaps begin to doubt

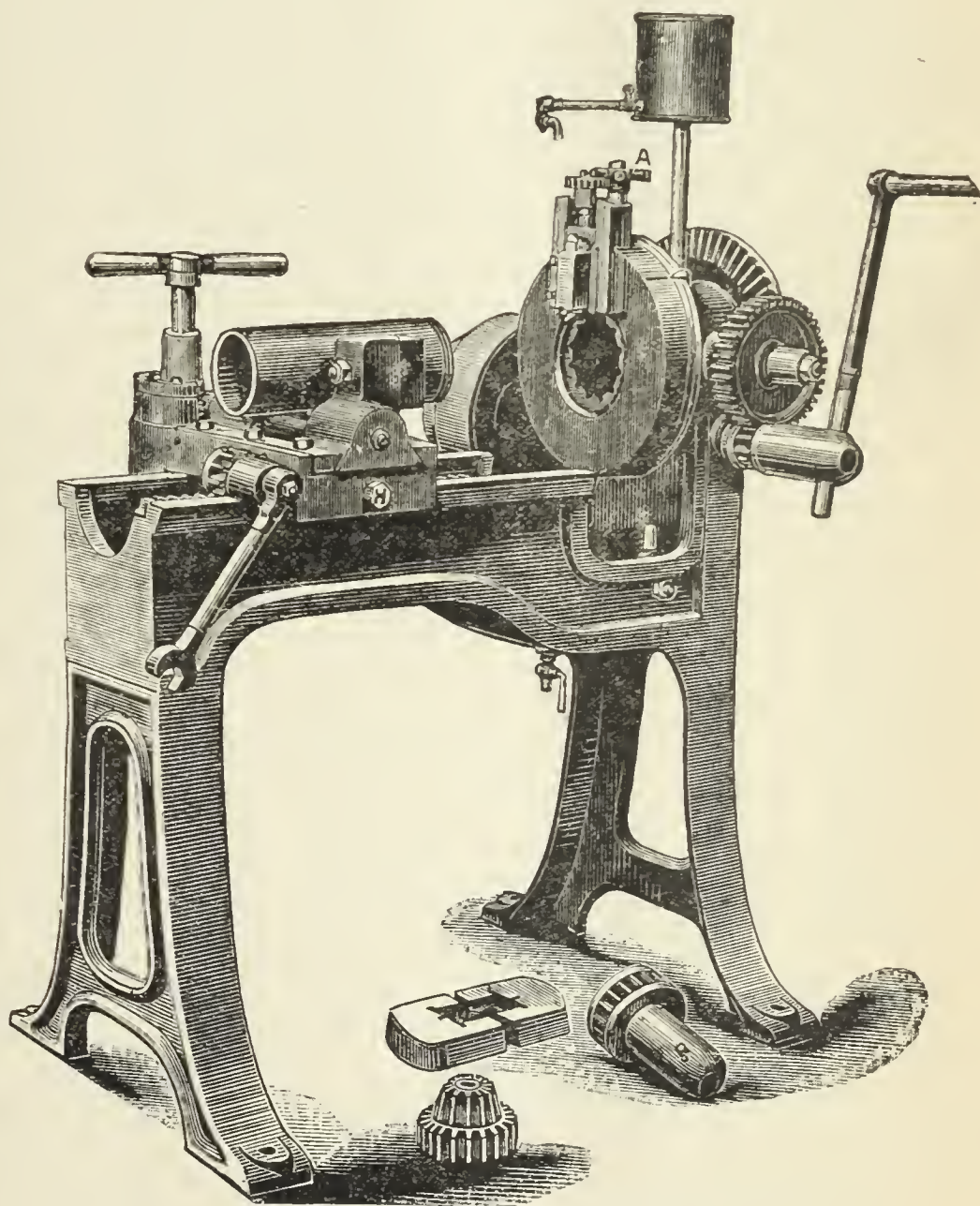

Cowley & Son's Tube Cutting and Screwing Machine.

whether this application of the electric light is such an unmixed blessing after all.

Regulating the Storage of Inflammable Substances in the District of Columbia.

The Commissioners of the District of Columbia, acting under the provisions of an act of Congress, approved Jan. 26, 1887, have published the following "police regulations" concerning the storage and sale, within the limits of the District, of the articles named:

"SEC. 1. No crude or refined petroleum, benzine, naphtha, turpentine, gasoline, or other highly inflammable oils or substances shall be stored

in any frame building or structure, or in any yard, or on any avenue, street, alley, sidewalk, parking, park, intersection, reservation, or public space within the District of Columbia; and all such articles and substances shall be removed by the consignee thereof from railroad depots or other places of consignment within 24 hours after notice of the arrival of the same.

SEC. 2. It shall be unlawful for any person to store or hold within any building in the District of Columbia, in any quantity whatsoever, any oil or any fluid made from petroleum or its product which will flash or give off an inflammable vapor at a temperature below 120° F., or have a density below 49° R. The chemist of the District of Columbia shall make the inspections and apply the tests provided for in this section.

SEC. 3. It shall be unlawful for any person to store or keep for sale in the District of Columbia any inflammable oil or fluid composed wholly or in part of petroleum, or any of its products, or any other highly inflammable fluid, without an annual license therefor first obtained from the Commissioners of the District, as provided in this article. Every person desiring such license shall make application therefor in writing to the said Commissioners, which application shall state the place, building, or part of building, in which the applicant desires so to store or keep such articles or any of them; and the said application shall be referred to the Inspector of Buildings and the Chief Engineer of the Fire Department of the District, who shall, within one week, examine the place or building described in the application and report in writing to the Commissioners their opinion as to the propriety of granting the license applied for. The fee for such license shall be \$3, which shall be paid to the Collector of Taxes of the District, to be applied to the expense of issuing such license and the inspections provided for by this Article.

SEC. 4. Every such license, when granted, shall begin and end with the fiscal year, and shall contain the name of the person licensed; a statement whether it is for storing or keeping, or both, the said articles or any of them; a description of the place, building or part of building for which the license is granted, and any limitations which the Commissioners may in each case see fit to impose upon the quantity of said articles, or of any of them, which may be stored or kept, or upon the manner of storing or keeping the same.

SEC. 5. A person holding such a license may store or keep said articles, or any of them, according to the terms of his license, either on his own account, or on account of any other person. Every person so licensed shall allow the Fire Marshal of the District, or such other person as may be designated by the Commissioners, to enter the premises described in his license, and to take such samples of said articles, and make such examinations of the said premises as the said Fire Marshal or other person aforesaid may deem expedient.

SEC. 6. No license will be granted for storing or keeping said articles, or any of them, in any part of a building occupied in whole or in part as a dwelling house; or upon any floor of a building above the first floor; or upon such first floor, unless the foundations and walls of the building are of brick, stone or iron, and the sills or walls are built without apertures for a space of at least one foot above such floor; and no license will be granted for storing or keeping crude petroleum, naphtha or gasoline in any part of a building above the cellar, unless said articles are contained in metallic vessels securely closed.

SEC. 7. No license will be granted for selling or keeping for sale at retail, for illuminating purposes, kerosene, refined petroleum or any product of petroleum which has not been inspected by the Chemist of the District, as provided in section one of this Article.

SEC. 8. Whoever, without a proper license therefor, as hereinbefore provided, shall store or keep any of the articles aforesaid, shall forfeit and pay a penalty of not less than \$10, nor more than \$100; and a violation of any of the terms of any license issued under this Article shall work a revocation of the same, and the Commissioners may at any time revoke any such license for other cause.

Notes from the West.

By RETORT.

JULY 8, 1887.

Steps have been taken anent the recently formed Chicago Gas Trust that will, in all probability, be finally settled by the Supreme Court, the agitators taking the ground that the charters of the more recently organized companies (the Consumers and the Equitable) contained provisos regarding the price at which gas was to be sold, and in definition of conditions which prohibited consolidation with companies already in existence or thereafter to exist. It is further asserted that such a combination of the nature of the present one "is contrary to public policy;" hence it is proposed to make the inquiry whether or not all the Chicago Gas

Companies have forfeited their franchises by entering into the existing "combine." The objects of the Gas Trust, as set forth in its articles of incorporation, are as follows:

"The object for which it is formed is to build, erect, purchase, lease, maintain, enlarge, extend, and operate or demise works in the city of Chicago, in the county of Cook, and State of Illinois, and in such other place or places in said State of Illinois as said corporation may by the vote of the majority of the stockholders elect, for the manufacture, supply, sale, and distribution of gas and electricity, or either, for the furnishing of light, heat, fuel, and power for any and all purposes for which gas or electricity may now or hereafter be used; and to purchase and hold or sell the capital stock, or purchase or lease or operate the property, plant, good-will, rights, and franchises of any gas works or gas company or compounds, or of any electric company or electric companies in said city of Chicago, Cook county, Illinois, or elsewhere in said State of Illinois, as said corporation may by vote of a majority of its stockholders elect; and to purchase, hold, sell, operate, or otherwise become interested in coal or other properties productive of material necessary or useful in the supply or manufacture of gas or other agency or medium of light, heat, power, or fuel, and to sell, improve, enlarge, extend, maintain, operate, or demise any and all property so purchased or leased."

The capital stock is \$25,000,000, divided into \$100 shares. Following is the way in which the shares were subscribed for:

Name.	Shares.	Amount.
C. G. Matthews	140,000	\$14,000,000
W. L. Elkins	1	100
P. A. B. Widener	1	100
C. T. Yerkes	1	100
W. W. Gibbs	1	100
C. R. Cummings	1	100
A. M. Billings	1	100
H. Fitzhugh	1	100
E. C. Benedict	1	100
S. A. Kent	1	100
P. A. McEwan	50,000	5,000,000
James Marsh	50,000	5,000,000
J. H. Winslow	9,991	999,100

The Chicago Tribune, of a recent date, says:

Messrs. McEwan and Marsh are probably representatives of Messrs. Kent and Cummings, and Mr. Matthews of Elkins and Widener, the Philadelphians. The directors elected at the first meeting were: Sidney A. Kent, Columbus R. Cummings, Charles T. Yerkes, A. A. Carpenter, C. L. Hutchinson, E. C. Benedict, Thos. Dolan, A. M. Billings, of the West Side Company, Peter A. B. Widener, William S. Elkins, William S. Reyburn, of the Consumers, Henry Fitzhugh, of the Equitable, and W. W. Gibbs. Probably nearly half of the stock of the Gas Trust is now in the market, selling at about 60 cents. Doubtless the majority will be held by the Philadelphians and their Chicago associates.

The first step toward combining the Chicago Companies was taken before the organization of the Gas Trust, when a majority of the stock of the South Side Company was bought by the Philadelphia syndicate, which later on sold its holdings to the Gas Trust. The Consumers went into bankruptcy, and was bought at court sale by Kent and Cummings, who subsequently sold to the Gas Trust. Then certain parties bought the whole or a majority of the stock and bonds of the Equitable, which, by the way, has yet furnished no gas, and disposed of that to the Gas Trust. That carried with it a large interest in the West Side Gas Company, but not a controlling one. Still later the additional stock needed to make a majority was secured, and along with it the control of the other West Side gas works on Division street. A majority of the stocks and bonds of the Hyde Park and Lake Companies were bought by Cummings and Kent, and then sold by them to the Gas Trust. That made a clean sweep of it. It will be seen that a majority of the Board of Directors of the Gas Trust can do about what they please in fixing the price of gas in Chicago and its vicinity, although technically not a single company has sold out to them or is seemingly controlled by them.

The charters of the two old companies and the city ordinances concerning them are silent on the subject of consolidation and combination. The ordinance which gave the Consumers Company power to operate works and lay mains in this city provides, however—

"And that such company or corporation will not sell, lease, or transfer its franchises and privileges to any other gas company, and shall and will not enter any combination with any other gas company concerning the rate (or price) to be charged for gas, and to pay all damages which the city of Chicago or any consumer of the gas furnished by such company or corporation shall suffer by reason of the failure of such company or corporation to perform any of the obligations or conditions of this ordinance."

A failure to live up to these conditions entails a forfeiture of the franchises. The company gave a \$500,000 bond that it would observe all these conditions, the bondsmen being the Consumers' Gas, Fuel and Light Company, of Chicago, as principal, and James W. Brockway, Richard S. Tuthill, Jesse S. Hildrup, Harvey T. Weeks, C. B. Farwell and Geo. H. Harlow as sureties. The Equitable ordinance has the same provision regarding combinations, but it is forbidden to sell out only to companies then existing—it is not forbidden to sell out to any company which might subsequently come into existence, like the Gas Trust.

Since it went into the hands of the Gas Trust the Chicago Gas Light Company has advanced its price 25 cents a thousand, the other companies have made no change. The Consumers' can by its ordinance charge up to \$1.75, and the West Side Company can go to \$2.50. There is no maximum price fixed for the Chicago Gas Light Company, and it can charge what it pleases. The gas men, therefore, will say that there has been no combination, for there is no uniformity of rates, and no company is now charging what the law allows it to; and that there has been no consolidation, because no corporation by its corporate act has sold or leased its property and franchises; that nothing forbids a stockholder in one gas company selling his stock to another gas company, an individual act not being a corporate one.

The questions, however, which will ultimately have to be decided are:

Whether a company can charge more than a reasonable price, even though the price demanded be less than the maximum fixed in its charter.

Whether it is not contrary to public policy to allow of the consolidation of gas companies when brought about by the act of the corporation or stockholders.

Whether that clause in the articles of incorporation of the Gas Trust allowing it to buy up franchises of other gas companies is not contrary to public policy, and therefore void.

ITEMS OF INTEREST FROM VARIOUS LOCALITIES.

ADDING TO THE KERR MURRAY COMPANY'S LIST.—We have been attempting to keep track of Bro. Cressler's movements, and thought we had succeeded fairly well; but the fact is he seems to have outjumped us. However, we herewith submit a list of the work that he has recently agreed to supply from the shops of the Kerr Murray Manufacturing Company, Fort Wayne, Ind.: A telescopic gasholder, 60 feet in diameter, with 14 feet lifts, to the order of the Wichita (Kas.) Gas and Electric Light Company. Single lift holders under contract include the following: El Paso (Texas) Gas, Coal and Coke Company, 60 feet diameter by 18 feet in depth; Pine Bluff (Ark.) Gas and Electric Light Company, 40 feet in diameter by 16 feet in depth; Fuel Gas and Electric Engineering Company, Pittsburgh, Pa., 60 feet in diameter by 18 feet in depth; Stillwater (Minn.) Gas Light Company, 60 feet in diameter by 18 feet in depth; Lexington (Mo.) Gas Light Company, 40 feet in diameter by 16 feet in depth; Dakota Gas and Fuel Company, Grand Forks, Dakota Ter., 33 feet in diameter by 14 feet in depth. The following benchwork is to be distributed as follows: Benches of fives for the gas plants at Huntsville, Ala., New Albany, Ind., and Sedalia, Mo., and a bench of threes for Shreveport, La. We may conclude the list by saying that self-sealing mouthpieces, and general work for benches of sixes, are to be put up in the Memphis (Tenn.) plant. We hope, for Cressler's sake, that it is cooler out his way than is the case (at the present writing) in New York city.

AFTER THE LIGHTING.—We understand that Penn Yan, N. Y., wants to be lighted by electricity, and that at least two electric companies are competing for the right to appease the demands of the residents—and Penn Yan is quite a small place.

PUBLIC LIGHTING IN OAKLAND, CAL.—We are indebted to a correspondent for the following: "Oakland pays out about \$30,000, on an average, for lighting its streets. In former years the Oakland Gas, Light and Heat Company has had no competition, but this year more than usual interest attaches to the letting of the contract, because the Pacific Coast Electrical Construction Company, and the Jenney Electric Light Company stated that they would endeavor to secure either a portion or all of the service. A special meeting of the City Council was held last night (Thursday, June 23) for the purpose of opening and reading the bids, and the following propositions were discussed: The Jenney Electric Light Company offered to furnish 175 lamps (2,000-candle power), to be mounted on masts, the latter to be either 100 or 125 feet in height, as desired by the authorities. The price named, per year per light, was \$163, the Company to maintain two lamps at the City Hall at its own expense. The bid was made on the basis of a two-year contract. The Pacific Coast

Electrical Construction Company offered to erect 160 lamps (2,000 candle power) on 125 feet masts, in consideration of a payment by the city of \$141 per year per light, or it would furnish any number of lights (to be located in accordance with mandate of Council) not less than 100, and up to 160, at \$155 per lamp per year, the contract to last for two years. One remarkable feature of the last bid—the feature is put forward as a reason why a contract should be granted—is the stress placed on the fact that the Company has invested a sum of money in a plot of land in the city, and has erected thereon a large and substantial building, furnished with a complete electric plant, including a 200-horse power steam provision. This plaint leads some of us to say, if such argument is to influence the authorities in their ultimate granting of a contract for the carrying on of the public lighting, that the Oakland Gas Company has been located here for some years, and originally took some pretty 'tall chances' in respect of the future growth of the Queen City of Alameda county. But, to finish my enumeration of the lighting propositions. The Oakland Gas, Light and Heat Company presented two bids—one to light the city with gas, and the other to do the work by electricity. Under the first it offered to maintain the present 872 gas lamps at the rate of 10½ cents per lamp per night. The bid for electric lighting assumed that in order to adequately light the city 350 arc lamps (2,000-candle power), on 75-foot masts, would be required, or 300 lamps in case 125-foot masts were used. The lights were to be maintained by the Company in consideration of a receipt of 60 cents per light, if a moon-table were followed, that sum to be increased to 80 cents in case the lamps were to be kept alight all night and every night in the year. I should have said that the electric bids, pure and simple, were based on the moonlight table. The bids were referred to the Street Light Committee of Council. Of course, it must seem somewhat hazardous were I to anticipate the action of the authorities in the premises; but let me here assume the uncertain (and unprofitable) *role* of a prophet by venturing the assertion that, whether gas or electricity be decided upon, the Oakland Gas Company is likely to be awarded the work. I think so simply because it is a corporation that stands well in the esteem of the people of our city, a position secured through its willingness to act fairly and equitably to those whom it serves. I will take pleasure in forwarding you information as to the final action of the authorities."

NEW GAS WORKS.—At a meeting of the City Council of Griffin, Ga.—held June 29—it was decided to authorize the construction of both gas and water works plant. It is presumed that these projects will absorb \$85,000, the scheme being to guarantee the constructors the right to supply the city with 80 public gas lamps, and 45 public hydrants. Griffin is the capital seat of Spalding county, Ga., and is on the old Georgia Central Railroad, where the latter joins the Savannah, Griffin and North Alabama Railroad. It is 43 miles south of Atlanta, and 60 miles west-northwest of Macon. It is a flourishing place, and has made much progress within the past five years. The population of Griffin must be close on to 5,000.

CHANGES AT WESTERLY, R. I.—At a recent meeting of the Board of Directors of the Westerly Gas Light Company the resignation of Mr. Jno. Loveland was read with regret and accepted with reluctance. Mr. Frank W. Taylor, who has been acting as master mechanic at the Carmichael mills, was appointed to succeed the retiring Superintendent who gave up the post of duty on Saturday last. Mr. Loveland has been Superintendent of the Westerly gas plant since the inception of the Company, in 1868. He was very generally esteemed. We wish Mr. Taylor all possible success in his management of the Westerly works.

THE DULUTH (IOWA) PLANT EXTENSIONS.—Some time ago we noted that the owners of the Duluth Gas and Water Company were about to make extensive plant alterations, and we are now in position to say that the betterments include the placing of extra large generators, and the placing of about 7 miles of gas mains, ranging between the extreme diameters of 4 and 10 inches. The water main system is to be extended a like number of miles, pipe diameters ranging between 6 and 20 inches. The pumping capacity of the plant is to be increased by the addition of a Worthington pump rated to a daily duty of 5 millions gallons. Mr. Wm. Craig, the General Manager of the Company, is a good one; he is not a bit afraid of work.

A SUIT COMPROMISED.—We are informed that, on June 30, an important suit pending between the gas and electric companies of Springfield, Mo., was compromised and dismissed. Although the Gas Company's exclusive franchise does not expire until 1892, last year the City Council contracted with the local electric light company for the maintenance of 50 arcs on streets not lighted by gas. When the electricians sought to obtain a payment on account of lighting duty performed, the

Gas Company sued out a writ of injunction restraining the authorities from handing over the money. Under the terms of the compromise the injunction is dissolved, and the electricians are permitted to maintain public lights on streets under which there are no gas mains, but shall remove said lights when the Gas Company puts its pipes in the said streets.

KILLED BY ELECTRICITY.—While attaching the wires of an arc electric light circuit to a ventilating fan motor in the kitchen of Lansing & Sickler's restaurant (No. 124 South Clark street, Chicago, Ills.), A. C. Holland, an electrician, was killed by the current. The accident happened on 1st inst.

MARINETTE (WIS.) TO HAVE GAS.—Responsible parties have applied to the authorities of Marinette for the right to construct a gas works at that place. The applicants are likely to succeed, and in view of a favorable response construction work is to be at once instituted. Marinette is a post village in Marinette township, Oconto county, Wis. It is on Green Bay, at the mouth of the Menominee river, and is about half a mile from Menominee, in Michigan. The Chicago and Northwestern Railroad passes through Marinette, which place is noted for its lumber mills.

SUITS FOR INFRINGEMENT.—We are informed that the Siemens-Lungren Company, of Phila., Pa., has brought suit against the U. S. Wenham Gas Lamp Company and the Sheldon Manufacturing Company, both of New York, for infringement of patent rights controlled by plaintiff.

TO BE LIGHTED BY ELECTRICITY.—Last April the City Council of Lafayette, Ind., contracted for the lighting of the city's public streets by electricity, 201 lamps having been determined upon. The intervening time (to June 30) has been taken up in getting the plant ready, and, as all arrangements have been perfected, Lafayette now has a chance to determine whether the new style is better than the old one. We await the verdict.

SUPERFLUOUS ELECTRIC LIGHTS.—The Music Teachers' National Association held their annual session this year at Tomlinson Hall, Indianapolis, Ind., and we are told that the sessions were characterized by concord and an appropriate volume of softened crescendo sound. Of course it is but natural to suppose that harmony would prevail amongst those who follow such a peaceful art, but it is to an echo that followed close upon the adjournment of the Association that we wish to call especial attention. No one will deny that the average daily newspaper man is much given to the manufacture of crescendo sounds when he toots his horn in regard to the virtue of the electric light as compared with the vice of gas light; hence we were hardly prepared for the bland note emitted by the Editor of the Indianapolis *Journal*, who, in commenting on the manner in which Tomlinson Hall was lighted during the gathering of the music teachers, said: "The gas chandeliers at Tomlinson Hall are sufficient to light that place, and do light it fully. The arc electric lights that are there are not only superfluous, but annoying and harmful to the eyesight." Truly, "music hath charms," etc.

CHEAPER GAS FOR PONTIAC, MICH.—We are informed by Mr. W. H. Morgans, Superintendent of the Medbury gas works, of Pontiac, that from and after August 1st the gross price for gas in that city is to be placed at \$2.50 per thousand cubic feet; but those who settle their bills, at the Company's office, on or before the 10th day from time of presentation of account are to receive a discount of 50 cents per thousand. Gas at \$2 in Pontiac looks like a cheap article, and we expect that Mr. Morgans' liberality will be appreciated by those to whose lighting needs he caters.

NAMED AS GAS INSPECTOR.—Mr. David A. Colton filed his official bond with the City Clerk of Detroit, Mich., on June 30. Mr. Colton is Detroit's gas inspector.

AT GREATER LENGTH.—In our current item columns we note that an application has been made for the right to construct a gas and water plant in Griffin, Ga. We can now add that Col. W. A. Jeter, representing the Brunswick (Ga.) Light and Water Company, was the applicant, and that his proposition to the City Council of Griffin was based on the following premises: The Light and Water Company to erect a gas and water plant at a cost of \$85,000, the city to bind itself to maintain 80 street lights and 45 hydrants, and to pay therefor the sum of \$4,000 per annum for a term of 25 years; also, to exempt the Company from the payment of taxes and license fees for the first ten years of its life. A second proposal was to the effect that, if the city preferred, the Company would erect the plants for \$85,000, and take in payment bonds of the city, to run 30 years and to bear 7 per cent. interest. If the first proposition

was accepted the Company was to bear all the expense of maintaining and keeping in order the hydrants and public lamps, including the lighting and extinguishing of the latter. We believe, however, that the city charter of Griffin will have to be altered by State legislation before the proposition submitted by Col. Jeter can be voted on by the inhabitants.

LIGHTED BY ELECTRICITY.—The Thomson-Houston Company's local branch at Augusta, Ga., commenced to supply light on date of June 30. The initial service was voted satisfactory by the residents; but the future will tell the story of its true merit.

PARTING WITH MORE OF ITS GAS STOCK.—Some time ago we noted that the authorities of Atlanta, Ga., had determined to dispose of a certain portion of the stock of the Atlanta Gas Light Company that was held by the city. The proceeds of the sale were to be devoted to equipping and beautifying the track and grounds of the Gentlemen's Driving Park Association, whose managers are largely interested in the yearly fairs held under the auspices of the Piedmont Fair Association. The aforesaid stock sale took place, and if we mistake not a very good average price was obtained for the security. At any rate it brought considerably over par, which must be reckoned as good evidence of the stability of a gas company that has been engaged in a gas war for several years. Having given the Driving Association a chance to put itself in shape, the city now proposes to aid the aims and ends of education, and the money for that object is to be secured in a manner similar to that which enabled the Driving Association to emerge from its conflict with a depleted treasury. The following advertisement, signed by John R. Gramling, Chairman Committee on Finance, explains what the city proposes to do in the matter: "In accordance with a resolution of the Mayor and General Council authorizing the same, and for the purpose of applying the proceeds thereof to the improvement of the female high school, and in constructing a new high school for boys, bids will be received for the purchase of 1,134 shares (\$25 par value each) of stock in the Atlanta Gas Light Company, belonging to the city of Atlanta. Bids will be received for the whole or for any number of said shares, up to 2 o'clock P.M. July 18, 1887. Bids to be sealed and addressed to the 'Clerk of Council, Atlanta, Ga.,' and marked 'Proposals for the purchase of gas stock.' The city reserves the right to reject any or all bids." We are sorry that the date selected for closing the bids follows so closely after the date of current issue of the *JOURNAL*, for no doubt many of our readers would like to bid for the securities which the Atlanta authorities seem to be so anxious to dispose of.

THE SPRINGER GAS APPARATUS.—We are in receipt of the following letter from the National Gas, Light and Fuel Company, of Chicago, Ills. It bears date of 7th inst., and carries its own explanation: "We are pleased to inform you that we have recently closed contracts for sets of Springer gas apparatus as follows: St. Paul (Minn.) Gas Light Company, daily capacity of 500,000 cubic feet; Stillwater (Minn.) Gas Light Company, capacity, 80,000 cubic feet; Sioux Falls (Dak. Ter.), capacity, 80,000 cubic feet. With reference to the first mentioned we would say that we think this the most emphatic indorsement we have ever received, as the St. Paul people had every opportunity to carefully investigate the results obtained at the Minneapolis plant. These were so satisfactory as to induce the St. Paul Company to discontinue its present water gas apparatus and adopt the Springer."

BRO. STEIN SAILS FOR EUROPE.—Brother Stein, of the Siemens-Lungren Company, of Phila., Pa., seems to have been so well pleased with his European trip of last winter that he must needs repeat that experience. At all events he departed from these shores per steamship *Trave*, on last Wednesday, and we hope that only pleasure awaits him.

MR. HOPPER'S NEW VENTURE.—We are in receipt of a letter from Messrs. T. C. Hopper & Co., No. 2227 Wood street, Phila., Pa., dated July 6, which notes that the orders now in hands of the Company include the following: *Automatic Differential Governors.*—Five 6-inch, three 8-inch, two 10-inch, two 12-inch, and one 20-inch. *Bye-Passes.*—Two 8-inch, and eight 10-inch. *Dry Center-Valve.*—One 10-inch. That looks like business.

A TRIBUTE TO THEIR LATE MANAGER'S WORTH.—Some time ago we chronicled the fact that Mr. W. A. Agard was to sever his connection with the Capital City (Des Moines, Iowa) Gas Light Company, and expressed our surprise that he should voluntarily retire from the management of a corporation on whose behalf he had always been so active and energetic. We must confess that we are still in the dark as to the reasons which impelled him to hand in his resignation, but beyond doubt they were based on proper grounds, for Mr. Agard is not likely to act on im-

pulse or without reason. Aside from any conjecture in the above regard, we may say that July 1st having been the last day of his connection with the Capital City Company, his employees determined also to make that day the occasion of showing how they regarded him in the light of his years amongst them. At noon, of July 1, the employees (fully 75 in number) gathered in a group at the works, and one of their number was delegated to invite Mr. Agard to bid formal good-by to his former co-workers. Having reached the group, and before a word could be spoken, Mr. J. S. McCormick addressed Mr. Agard thus: "My dear sir—Delegated by my associates for this pleasant duty, I present you with this address. In it we strive to commemorate your services to the Company and kindness to us, and to indicate the gratitude I cannot express for what you have done for us during the long time we have been together. Mr. Agard, I feel that the language of compliment is in this case superfluous. Were this an occasion of rejoicing, many things I might then say to testify, not alone my sentiments, but to voice as well the esteem of those you see around you, who so long have faithfully served you because it was a pleasure to do so; but this is rather a time of sorrow, of regret, and I can only say that wherever you go, whatsoever friends you may make (and may their name be legion) you will find none more anxious for your happiness, more earnest for your welfare, more desirous that all good things may be given you, than we are, your old associates and friends, who are here assembled to bid you farewell." In concluding his remarks the speaker presented Mr. Agard with the following address, which bore the signatures of his former associates: "Address to W. A. Agard, of the Capital City Gas Light Company (upon the occasion of his resigning his position of manager), by his employees: Dear Sir—With feelings of sincere regret we have learned that you are about to sever your connection with the Company, and that the relations which heretofore existed between us are about to be terminated. We are desirous of perpetuating the evidences of our esteem and affection, and of our good wishes for your future welfare. During the past ten years we have been associated together under your management, and we are gratified to be able to say that no dissensions such as too frequently disorganize business interests, and disturb the relations between employer and employed, have ever interrupted the harmony which has contributed so largely to the prosperity of the Company. Strikes and suspensions, lockouts and disturbances have never occurred among us. Your kindness and forbearance have never failed us, and we have striven to repay with faithful service the obligations to you, by which we are bound in gratitude and esteem. To the solution of the vexed problems of labor and capital you brought sympathy, kindness and justice, and the happy results thus achieved we may well wish could be attained by others. In the new fields of usefulness to which you go, you may feel assured our gratitude, esteem and affection follow you, and that fortune may be as kind to you as you have been to us is our most earnest wish and heartfelt desire." Now, we submit that the above is convincing testimony as to the manner of man that Brother Agard is, and to show that not only his employees but also the people of Des Moines hold like views in regard to him, we extract the following comments (published in the *Iowa State Register*, July 2) made by a local newsman in respect of the sentiments contained in the address as given above: "A more sincere and deserved tribute was never paid a man by those who had occasion to know him in every aspect of life, and it could not but be pleasing to the gentleman who had so thoroughly won it. During the ten years of Mr. Agard's life in this city he has steadily won his way in the respect and esteem of those with whom he came in contact, and his loss will be deeply felt in the community." Mr. Agard, we understand, will pass the remainder of this summer in Tolland, Conn., where he expects to enjoy the pleasures of a well-earned vacation. In the meantime, we are pleased to say, Mr. E. G. Pratt, who succeeded Mr. Agard at Des Moines, is meeting with the true measure of success that real merit deserves.

NO OPPOSITION CHARTER FOR DUBUQUE, IOWA.—Not long ago we called attention to a proposition made to Council by certain Dubuque parties who claimed to represent large holders of Eastern capital, under which the agitators sought to obtain a charter to operate a gas works in opposition to the old Key City Gas Company, of Dubuque. Of course, the threadbare banner bearing the promise of relief to the citizens from the oppression of an arrogant monopoly was unfurled; but somehow or another that ancient rag with its unhallowed inscription fails to flaunt as airily now as it did when the shoddy of its pledges had not been detected by means of the test of promises unfulfilled. Well, the Dubuque opposition flag flaunts no longer over Bro. Howard's devoted head, for the City Council (on date of June 30), in Committee of the Whole, declared, "That it is inexpedient to grant a charter to a new gas Company at this time, and that said application for a charter be rejected." Of course, it

is quite an easy matter for City Councils to break their faith with corporations, and we have had plenty of examples in proof of the ease with which such pledges are cast aside; but the Dubuque case happily affords an instance where the Council determined to live up to its word—although at one time it seemed as if the "word" was valueless. The city of Dubuque, on March 13, 1884, entered into a contract with the Key City Gas Company under the terms of which the latter was to be granted entire possession of the lighting field (for a period of 10 years, from July 1, 1884), provided that during the first five years of the agreement the Company supplied gas to the city at \$2 per thousand, and to the public at \$2.50. During the last 5 years of the contract the city was to be supplied at \$1.50 per M., and the public at \$2.25. No one claimed or averred that the Key City Company had violated the agreement, nevertheless the speculators, depending on certain influences that could be brought to bear in the proper direction, boldly asked that Dubuque should violate the civic end of the bargain; and that is the true extent of their modest(?) demand. However, since they were foiled, perhaps we might better turn aside from them, and place before our readers the action taken by the Key City gas men on the day following the final action of the Council. This will be understood on a perusal of the following resolution, passed by the Company's Directors on July 1: "Whereas, this Company wishes to show its appreciation of desire of Council to maintain in good faith the existing contract between the city and the Gas Company, it is resolved that this Company will now voluntarily so far modify the terms of said contract with the city as to charge for the remaining portion of the first period mentioned in said contract the reduced rates agreed upon for the second term; and from and after the first of July, 1887, will charge the city of Dubuque for gas at the rate of \$1.50 per thousand cubic feet, private consumers to be charged at the rate of \$2.25 per thousand." Messrs. Bell, Rider and Howard were evidently equal to the occasion, and know how to be generous in the hour of victory.

PURCHASED.—Messrs. A. N. Bradley and R. C. Pyrne, acting on behalf of the Municipal Gas Company, of Albany, N. Y., are said to have acquired the property of the West Troy Gas Company, paying therefor at the rate of 108.

CHEAPER GAS FOR GLOUCESTER, MASS.—Brother Coffin, of the Gloucester Gas Light Company, is fishing after the local public purse again, for he informs us that, beginning with 1st. inst., the gross price for gas consumed has been placed at \$2 per thousand. A discount of 10 per cent. is granted when bills are paid on or before the 15th of the month in which they are presented. The gas stove business is flourishing in Gloucester, and we submit that \$1.80 is a low price for gas in a city where at least 25 per cent. of the work done on main excavation must be carried on in solid rock. We notice that Brother Coffin, in his circular announcing the reduction, threatens to come down again, if the people will only help him.

NEW PLANT.—We are informed that the Washington (D. C.) Gas Light Company's plant is to be duplicated in the near future. The works will be constructed on land owned by the Company, just east of the Navy Yard, between M and N streets, and 12th and 13th streets, southeast.

BRO. HARBISON GOES TO EUROPE—BY PROXY.—The General Manager of the Hartford (Conn.) Gas Light Company, having placed a large portion of his earthly hopes in line with a desire to sell gas at a dollar a thousand, is now busily engaged in reconstructing the Hartford plant in order that a broad road to the dollar-way may be opened up. Thus hampered, of course he could not conscientiously pack his traps and hie him off to Europe; but Harbison, being fertile in expedient, devised a way out the dilemma, and the result is that his daughter, Miss Mamie L. F. Harbison, in company with the Reverend Dr. Parker and his daughter, Miss Lily Pond Parker, sailed for Europe, per steamship Hammonia, from this port on Thursday, July 7.

AND YET ANOTHER.—Mr. Eugene Vanderpool, President of the Newark (N. J.) Gas Light Company, accompanied by his family, sail for Europe, per steamship Saale, on the 20th inst.

A SUPERINTENDENT FOR SPRINGFIELD, MASS.—We understand that the Springfield Gas Light Company is to engage Mr. E. P. Holly (son of Mr. Birdsell Holly of water-works fame) as Superintendent. This will be a decided relief to Treasurer Hallet, who has been carrying too heavy a load on his shoulders.

TO PURCHASE THE PLANT.—The city authorities of Alameda (Cal.) have decided to purchase the local electric lighting plant.



A. M. CALLENDER & CO.,
PROPRIETORS.

Editor—JOS. R. THOMAS, C.E.
Asst. Editor—T. J. CUNNINGHAM.
Manager—C. E. SANDERSON.

PUBLISHED ON THE 2ND AND 16TH OF EACH MONTH
At No. 42 Pine Street, New York.

This is a recognized official organ of—
LIGHT, HEAT, STEAM, WATER-SUPPLY,
VENTILATION, SANITARY IMPROVEMENT,
AND GENERAL SCIENCE.

TERMS

SUBSCRIPTION—Three Dollars per annum, in advance.

AGENTS

NEW YORK—AMERICAN NEWS Co. 39 and 41 Chambers St.
BOSTON—S. M. PETTENGILL & Co., 6 State Street.
PHILADELPHIA—PRATT & Co., Corner 9th and Arch Streets.
England—C. W. HASTINGS, 22 Buckingham St., London, W C
Germany—B. WESTERMANN & Co., of New York

SATURDAY, JULY 16, 1887.

Kokomo (Ind.) and Her Gas Well.

The Kokomo (Ind.) *Dispatch*, of June 30, thus dilates on the gas well now known to fame as the "Great Five":

Two hours after the *Dispatch* was on the streets last Thursday, and while the public was yet scanning its modest account of the great gas find on the Sharader farm, 1½ miles southeast of the city, a second report came in.

The great drill, weighing upward of 2,200 pounds, with 900 feet of 2-inch cable at its back, that was powerless against the mighty flow of gas the night before, had been extra weighted and driven three feet further in the sand.

The result was marvelous.

What was before the best gas well in Indiana is to-day the equal, if not the superior, of any in America.

Kokomo rests at last. She will have nothing but the best. She has it. She is satisfied.

We had good wells before. They were above the average. But the Great Five is to them as Hyperion to the Pleiads.

Its magnitude is universally acknowledged. Of one accord, all who see it pronounce it King.

* * * * *

Only during the bustle and noise of the busy hours is the constant roar of the freed monster unheard, even in the heart of the city. About the quieter suburbs its hoarse voice is never silent. Alighting from the night trains at the upper railway stations, the first thing that greets the visitor's ear after the din of puffing engines is hushed is a steady, rumbling sound, like the near approach of a heavily laden train of cars. So complete is the illusion that he instinctively turns and glances down the

track, expecting to see the flashing headlight of the coming locomotive. Instead, he beholds far away on the dark southern horizon a bright reflection, steady and undiminishing as the boreal lights, for which, indeed, but for the season and its southerly location, it might be mistaken. He is quite three miles away from the Great Five, and it is said that twelve miles further to the northward the effect is not materially changed.

Mounting a hack, he is driven southward through the city, crossing the river by the Union street bridge. The reflection on the heavens gathers and spreads, mounting upward and upward like the burning of a hundred hayricks against an autumn sky. The sullen roar has increased to the loud, hoarse moan of an approaching hurricane sweeping through a distant forest. The rattling of the lumbering hack over the stones is no longer heard, and the passenger makes a trumpet of his hand to address the driver, as one on ship-board in a storm.

The summit of a hill is reached. Through the entwined boughs of trees a seething lake of fire is seen, while great tongues of flame leap skyward, seeming to lick the overhanging clouds. The noise now is like that of a mountain cataract, rushing with the volume of a Niagara. No one attempts to speak; that would be useless. A turn in the road to the east opens a panorama of sharp contrasts. To the right miles of fields, the golden color of their garnered grain heightened in the unnatural light; red-roofed barns, vine-clad cottages, great white farm houses; the frightened cattle, unaccustomed to the new intrusion on their sleeping hours, huddled together in dumb fear. To the left the roaring, blazing, quaking disturber of this pastoral quiet, making the very earth tremble with its unpent might, and paling the harvest moon to an ineffectual star by its dazzling brilliancy.

That's the great Five, the newest wonder, the King of Gas Wells.

* * * * *

They call it the King.

The roar is heard 18 miles.

People go into the next county to sleep.

The reflection is seen at Frankfort, 28 miles.

Three self-binders were put in the fields on the Sharader farm last night, cutting grain by the light of the Great Five.

The Market for Gas Securities.

The city gas share market has settled down to the slow routine of a decidedly dull summer season. It is true that quotations regularly appear on the tape, and it is also true that these quotations of late have been made on very low figures. In fact the uninitiated might be excused for thinking that Consolidated was on its last legs—or nearly so. The real state of the case, however, is this. The general stock market is in a very unsettled condition, and during these semi-panicky times the speculators pay no attention to the miscellaneous list. At time of writing (noon, July 14), 77 is bid for the stock; but we venture to say that a commission to purchase 500 shares, "at the market," would drive it up to 80. Mark what we say; Consolidated is a purchase at 80 or under. Other city shares are dull and neglected. In Brooklyn a better feeling is exhibited, and we believe that anything on the list, at present figures, offers a chance for a fair profit. The Baltimore see-saw

is at work again, Consolidated having advanced about 10 points within the fortnight; but perhaps it might better be let alone. However, we cannot help admitting that it looks tempting. As a rule, it may be written down that dullness reigns supreme.

Gas Stocks.

Quotations by Geo. W. Close, Broker and Dealer in Gas Stocks.
16 WALL ST., NEW YORK CITY.

JULY 16.

All communications will receive particular attention.
The following quotations are based on the par value of \$100 per share.

	Capital.	Par.	Bid	Asked
Consolidated.....	\$35,430,000	100	77½	—
Central.....	440,000	50	30	—
“ Scrip.....	220,000	—	47	57
Equitable.....	2,000,000	100	120	125
“ Bonds.....	1,000,000	—	113	115
Harlem, Bonds.....	170,000	—	—	—
Metropolitan, Bonds....	658,000	—	110	113
Mutual.....	3,500,000	100	102	105
“ Bonds.....	1,500,000	1000	101	—
Municipal, Bonds.....	750,000	—	—	—
Northern.....	125,000	50	30	—
“ Scrip.....	108,000	—	—	—
Yonkers	—	50	—	80
Richmond Co., S. I....	300,000	50	50	—
“ Bonds.....	12,000	—	—	—
Gas Co's of Brooklyn.				
Brooklyn.....	2,000,000	25	107	108
Citizens	1,200,000	20	58	—
“ S. F. Bonds....	320,000	1000	—	103
Fulton Municipal.....	3,000,000	100	—	141
“ Bonds....	300,000	—	—	106
Peoples	1,000,000	10	62	64
“ Bonds (5's).....	368,000	—	97	—
“ “ (6's).....	94,000	—	100	—
Metropolitan.....	1,000,000	100	85	—
Nassau.....	1,000,000	25	105	—
“ Cdfs.....	700,000	1000	100	—
Williamsburgh.....	1,000,000	50	—	128
“ Bonds... ..	1,000,000	—	111	—
Out of Town Gas Companies.				
Boston (Mass.) Gas Co.	2,500,000	500	193	200
Buffalo Mutual, N. Y... ..	750,000	100	90	95
“ Bonds.....	200,000	1000	95	100
Citizens, Newark.....	1,000,000	50	140	145
“ “ Bonds.....	45,000	—	—	—
Chicago Gas Trust.....	—	100	59	60
Cincinnati G. & C. Co..	6,000,000	100	184	185
Consolidated, Balt.....	6,000,000	100	66½	—
“ Bonds....	3,600,000	—	107	107½
Chesapeake, Balt.....	1,500,000	100	85	—
“	1,000,000	—	100	102
Consumers Toronto....	1,000,000	50	192	—
Central, S. F., Cal.....	—	—	86	100
Capital, Sacramento, Cal.	—	—	56	58
Hartford, Conn.....	750,000	25	140	142
Jersey City.....	750,000	20	168	—
Laclede, St. Louis, Mo.	2,000,000	100	125	—
Louisville, Ky.....	2,570,000	50	130	132
Little Falls, N. Y.....	50,000	100	95	100
“ Bonds.....	25,000	—	100	103
Montreal, Canada.....	2,000,000	100	220	221
New Haven, Conn.....	—	25	193	197
Oakland, Cal.....	—	—	37	37½
Peoples, Jersey City... ..	—	—	25	30
“ “ Bonds.. ..	—	—	—	—
Paterson, N. J.....	—	25	90	—
Rochester, N. Y.....	—	50	75	80
Syracuse, N. Y.....	350,000	25	—	—
St. Louis, Missouri.....	600,000	50	—	—
San Francisco Gas Co.				
San Francisco, Cal....	10,000,000	100	60	60½
Memphis (Tenn.) Gas... ..	750,000	100	—	—
“ Bonds.....	240,000	100	103	—
Washington, D. C.....	2,000,000	20	210	—
Wilmington, Del.....	—	50	200	208
Havana (Cuba) Gas Co.	3,000,000	100	18	20
“ Bonds.....	550,000	—	102	—

Advertisers Index.

GAS ENGINEERS.	
Jos. R. Thomas, New York City	56
Wm. Heury White, New York City	56
Wm. Mooney, New York City	56
William Gardner, Pittsburg, Pa.	56
GAS WORKS APPARATUS AND CONSTRUCTION.	
James R. Floyd, New York City	59
T. F. Rowland, Greenpoint, L. I.	59
Delly & Fowler, Phila., Pa.	59
Kerr Murray Mfg. Co., Fort Wayne, Ind.	58
Stacey Mfg. Co., Cincinnati, Ohio	59
Bartlett, Hayward & Co., Baltimore, Md.	49
Morris, Tasker & Co., Limited, Phila., Pa.	58
Davis & Faruun Mfg. Co., Waltham, Mass.	15
R. D. Wood & Co., Phila., Pa.	58
Southwark Foundry and Machine Co., Philadelphia, Pa.	58
Bouton Foundry Co., Chicago, Ills.	55
Smith & Sayre Manufacturing Co., New York City	59
PROCESSES.	
National Gas Light and Fuel Co., Chicago Ills.	50
GAS AND WATER PIPES.	
Gloucester Iron Works, Phila., Pa.	56
Mellert Foundry and Machine Co., Reading, Pa. (John Fox, Selling Agent, N. Y.)	56
Cincinnati and Newport Iron and Pipe Co., Newport, Ky.	56
Ohio Pipe Co., Columbus, Ohio	56
Pancoast & Rogers, New York City	56
M. J. Drummond, New York City	56
Wells Rustless Iron Co., New York City	48
R. D. Wood & Co., Phila., Pa.	58
GAS ENGINES.	
Schleicher, Schumm & Co., Phila., Pa.	64
Clerk Gas Engine Co., Phila., Pa.	51
RETORTS AND FIRE BRICK.	
J. H. Gautier & Co., Jersey City, N. J.	54
B. Kreisler & Sons, New York City	54
Adam Weber, New York City	54
Laclede Fire Brick Works, St. Louis, Mo.	54
Brooklyn Retort and Fire Brick Works, Brooklyn, N. Y.	54
Borgner & O'Brien, Phila., Pa.	54
James Gardner, Jr., Pittsburg, Pa.	54
Heury Maurer & Son, New York City	54
Chicago Retort and Fire Brick Works, Chicago, Ills.	54
Baltimore Retort and Fire Brick Co., Baltimore	54
Oakhill Gas Retort and Fire Brick Co., St. Louis, Mo.	54
Evens & Howard, St. Louis, Mo.	55
Cincinnati Gas Retort and Fire Brick Works, Cincinnati, O.	55
Emil Lenz, New York City	55
SCRUBBERS AND CONDENSERS.	
G. Shepard Page, New York City	57
R. D. Wood & Co., Phila., Pa.	58
REGENERATIVE FURNACES.	
Bartlett, Hayward & Co., Baltimore, Md.	49
Fred. Bredel, New York City	55
GAS GOVERNORS.	
T. C. Hopper, Phila., Pa.	52
Connelly & Co., New York City	51
CEMENTS.	
C. L. Gerould, Manchester, N. H.	54
GAS ENRICHERS.	
Standard Oil Co., Cleveland, Ohio	60

GAS METERS.	
Harris, Griffin & Co., Phila., Pa.	62
American Meter Co., New York and Philadelphia	63
The Goodwin Gas Stove and Meter Co., Philadelphia, Pa.	63
Helme & Melhenny, Phila., Pa.	63
D. McDonald & Co., Albany, N. Y.	63
Nathaniel Tufts, Boston, Mass.	62
EXHAUSTERS.	
P. H. & F. M. Roots, Connersville, Ind.	50
Smith & Sayre Manufacturing Co., New York City	59
Wilbraham Bros., Philadelphia, Pa.	51
Connelly & Co., New York City	51
GAS COALS.	
Penn Gas Coal Co., Phila., Pa.	61
Perkins & Co., New York City	60
Newburgh Orrel Coal Co., Baltimore Md.	61
Despard Coal Co., Baltimore, Md.	61
Chesapeake and Ohio R.R. Coal Agency, N. Y. City	61
Westmoreland Coal Company, Phila., Pa.	61
Monongahela & Peters Creek Gas Coal Co., Pittsburgh, Pa.	61
CANNEL COALS.	
Perkins & Co., New York City	60
J. & W. Wood, New York City	60
VALVES.	
Ludlow Valve Manufacturing Co., Troy, N. Y.	52
John McLean, New York City	52
Chapman Valve Manufacturing Co., Boston, Mass.	52
R. D. Wood & Co., Phila., Pa.	58
ENGINES AND BOILERS.	
Jarvis Engineering Co., Boston, Mass.	51
PURIFYING MATERIAL.	
S. H. Douglas, Ann Arbor, Mich.	55
Connelly & Co., New York City	51
GAS LAMPS.	
The Siemens-Lungren Co., Philadelphia, Pa.	57
G. Shepard Page, New York City	24
Albo-Carbon Light Co., Newark, N. J.	49
Standard Gas Lamp Co., Phila., Pa.	55
PURIFIER SCREENS.	
John Cabot, New York City	55
Geo. A. Mills, Baltimore, Md.	55
GAS STOVES.	
American Meter Co., New York and Philadelphia	53
The Goodwin Gas Stove and Meter Co., Phila. Pa.	32
STREET LAMPS.	
J. G. Miner, Morrisania, New York City	47
Bartlett Street Lamp Mfg Co., New York City	52
BURNERS.	
G. Gfroerer, Phila., Pa.	60
STEAM BLOWER FOR BURNING BREESE.	
H. E. Parson, New York City	58
GASHOLDER TANKS.	
W. C. Whyte, New York City	48
GAS FIXTURES.	
Mitchell, Vance & Co., New York City	52
COKE CRUSHER.	
C. M. Keller, Columbus, Ind.	61
GAS BAGS.	
Peerless Manuf'g Co., New York City	51
ELECTRICAL APPARATUS.	
Waterhouse Electric & Manufg Co., Hartford, Conn.	48

BOOKS, ETC.	
English Journal of Gas Lighting	47
Gas as a Source of Light, Heat and Power	52
Goodwin's Directory of Gas Light Companies	60
King's Treatise	62
Scientific Books	62
Management of Small Gas Works	52
Newbigging's Gas Manager's Handbook	62
Gas vs. Electricity	59

Engagement Desired.

The advertiser, an English Gas Engineer, age 25, seeks an engagement
As Gas Works Manager or Assistant Manager.
 Thoroughly understands the manufacture and distribution of gas, and is a good draughtsman and chemist. Address
 672-Gt "H." care this Office.

**FOR SALE,
 Two Sinuous Friction Condensers,**

Each 1 ft. 3 in. wide by 11 ft. 3 in. long, and 18 ft. high, of sufficient capacity for 225,000 cu. ft. per day. Apply to
 665-12 PETER COFFEY, Supt. Gas Co., Peoria, Ill.

**ENGLISH
 "Journal of Gas Lighting."**

Issued weekly. New volume commences Jan. 1, 1887. Price, \$7 per annum. Subscriptions taken by
CHARLES NETTLETON, Agent for U. S.,
 No. 115 BROADWAY, N. Y. CITY.



Are adapted for use of Streets, Parks, Depots, Ferries, & Private Grounds.
 WITH POSTS OR BRACKETS.

Jacob G. Miner,
 No. 823 Eagle Ave., New York, N. Y.

To All Whom It May Concern!

The SIEMENS-LUNGREN COMPANY hereby warns the public against the use of various infringing Regenerative Gas Lamps which are offered for sale. This Company has heretofore delayed bringing suit to enjoin the manufacture or importation of such infringing lamps, solely because of the practical worthlessness of the infringing devices; and although, in each instance, they infringe some one or more of the various patents owned or controlled by this Company, they have fallen into disuse sooner than any suit could be brought to a hearing. As, however, the introduction of these infringing lamps has tended to discredit the practicability of our Company's system of regenerative gas lighting, we have instructed our Attorneys, Messrs. Geo. Harding, C. S. Whitman, and Silas W. Pettit, to give notice that legal proceedings will in future be taken against all such infringers.

THE SIEMENS-LUNGREN CO., 21st St. & Washington Av., Phila., Pa.

THE ALBO-CARBON LIGHT!

The Perfection of Gas Lighting.

Producing the Highest Illumination yet obtained from Gas, and

EFFECTING A SAVING IN ITS CONSUMPTION.

It has been most effective in

Replacing Electricity,

AFFORDING A

SOFT WHITE LIGHT

of EXTREME BRILLIANCY & POWER.

It has been most successful in

Supplanting Kerosene,

Giving Increased Light, Less Heat, and Perfect Safety

WITHOUT ADDITIONAL COST.

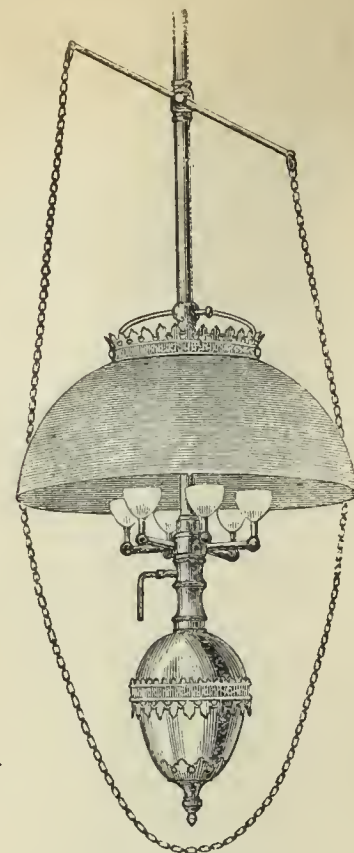
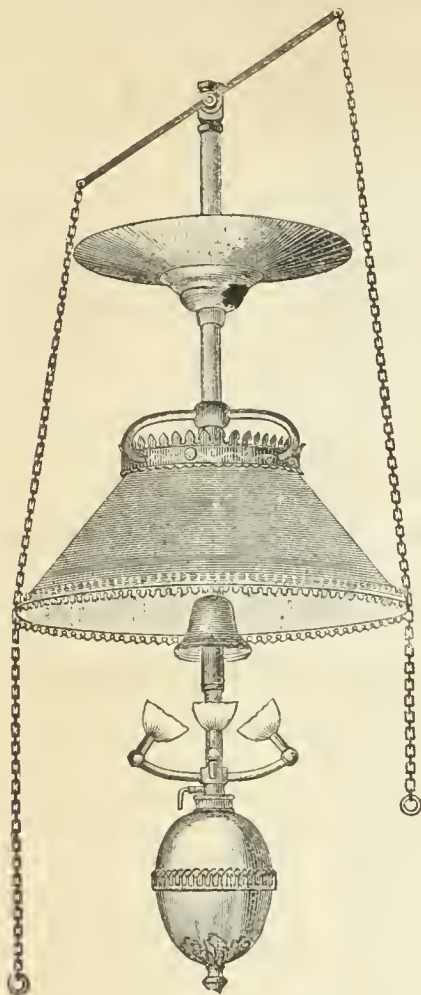

NOTICE.—Suits are pending in the United States Circuit Courts in Illinois and Pennsylvania against various parties for infringement of our Letters Patent No. 247,925, dated October 4, 1881, and No. 333,862, dated January 5, 1886. The first of these suits has come up for hearing, and an injunction has been granted therein. The second of said suits has not yet been reached for hearing. All persons are cautioned against manufacturing, selling, or using any apparatus or material which infringes our Patents. We intend to prosecute all parties infringing patents owned by us.

THE ALBO-CARBON LIGHT COMPANY, - - - NEWARK, N. J.,
Sole Manufacturers for the United States.

ELECTRIC ARC LIGHTING.

OFFICE OF CHURCH & Co.,
129 PEARL ST., N. Y., May 10, 1887. }

THE WATERHOUSE ELECTRIC AND MFG. Co.: Gentlemen—The record of the gentlemen connected with your Company for the production of first-class machinery led us to suppose that the workmanship of your apparatus, from a mechanical point of view, would be all that could be desired. Upon investigation we learned that the plants installed were giving entire satisfaction. The Harlem Lighting Company speak in the highest terms of your system, and certainly the wonderfully steady light produced from their station warrants the endorsement.

On this information we ordered a plant for our factory, and would say that you have fulfilled our expectations. The dynamo is the smoothest and stillest running machine we have seen, and the workmanship is indeed

first-class. The regulator performs its work, for we have run ten arc lights on our 35-light machine without an over-production of current, and with the machine perfectly cool. The exhibition made on starting the plant was as fine a test of automatic regulation as we ever expect to witness. With all of our lamps burning, the machine was connected at the binding posts, instantly cutting out all of the lamps and placing the machine in short circuit, and the machine was run in short circuit until satisfaction was made that we were satisfied.

In fact, your representations of regulation, power required, and steady light we think are well sustained. The light is perfectly adapted for inside illumination. We congratulate ourselves in securing such a fine system of electric lighting, for it is indeed a puzzle, amid all of the stalwart claims of the various systems, to select the best. Yours truly, CHURCH & CO.

A STRICTLY FIRST-CLASS SYSTEM OF ARC AND INCANDESCENT LIGHTING.

MANUFACTURED BY

THE WATERHOUSE ELECTRIC AND MFG. COMPANY,
Factory, Colt's West Armory. **Hartford, Conn.**

Water & Gas Pipe.

RUSTLESS

Send for New Catalogue.

RUSTLESS

The WELLS RUSTLESS IRON COMPANY,
Nos. 7 and 9 Cliff Street, New York City.

GASHOLDER TANK CONSTRUCTION, ETC.

Gas Companies and others about to erect Gasholders will find it profitable to consult W. C. WHYTE, who for over thirty years has made a specialty of

Holder Tank Excavation and Mason Work.

Fifty tanks now in operation show the sort of work done. Address

W. C. WHYTE, No. 15 Cortlandt St., N. Y. City.

BOOKS.

DISTILLATION OF COAL TAR AND
AMMONIACAL LIQUOR.

By GEORGE LUNGE. Price \$8.50.

A TREATISE ON THE COMPARATIVE
COMMERCIAL VALUES OF GAS
COALS AND CANNELS.

By DAVID A. GRAHAM. 8vo., Cloth. Price \$3.

Orders for these books may be sent to this office.

A. M. CALLENDER & CO.,

42 PINE ST., N. Y. CITY.

BARTLETT, HAYWARD & CO.

Baltimore, Md.

Munich Regenerative Furnace, System Drs. Schilling & Bunte.

Greatest durability; minimum of attention; complete distillation in 3½ hours; 10 to 13 pounds of coke to hundred-weight of coal; no clinker; no carbonic oxide in regenerative flues.

TWO AND THREE-LIFT TELESCOPIC GASHOLDERS,

With Wrought Iron Tanks, constructed above ground, of any magnitude.

Condensers, Scrubbers, Purifiers, Bench Castings, Roofs, Boilers, Etc.

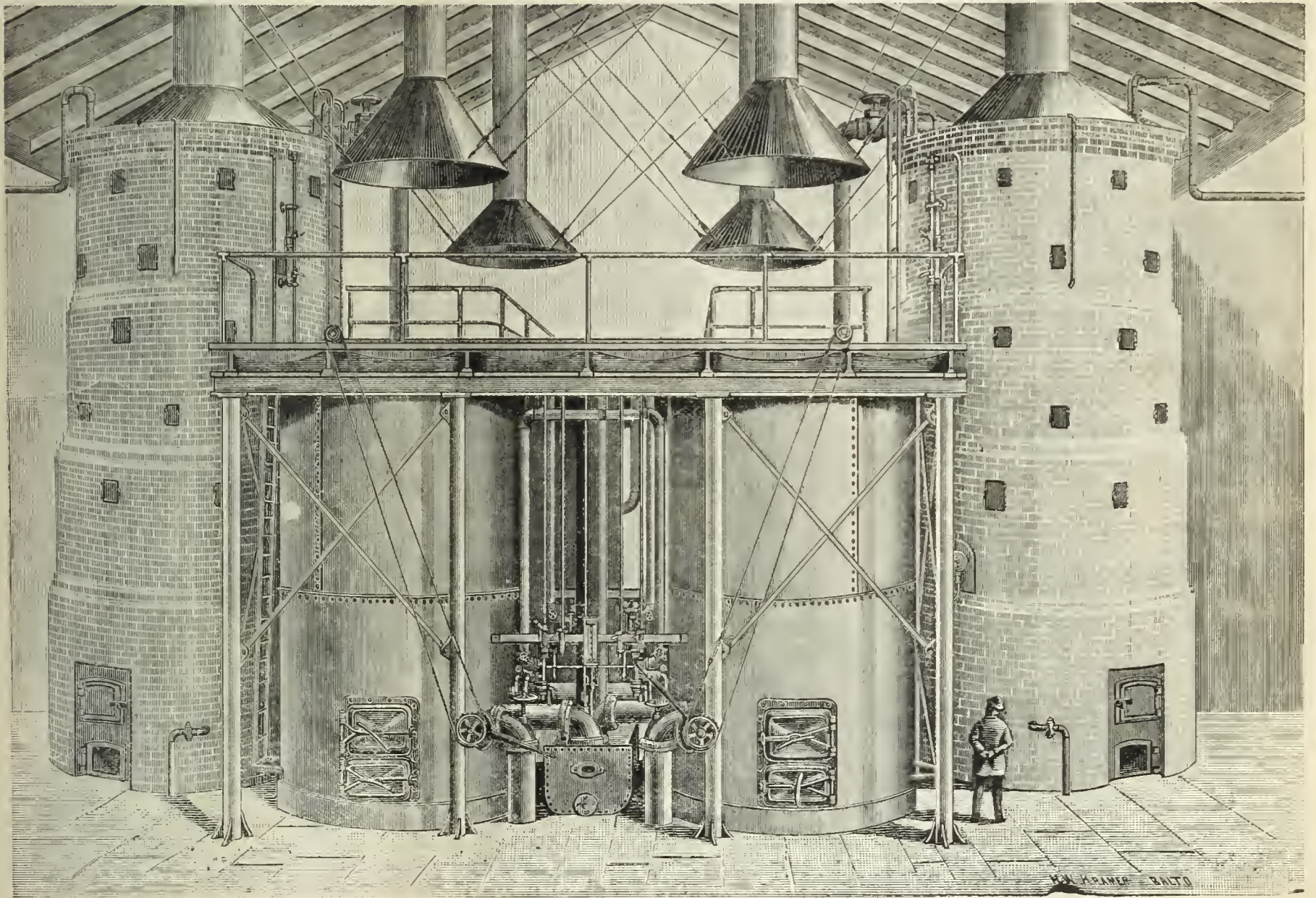

The Wilkinson Water Gas Process.

Introducing the Munich Regenerative Furnace for Coal Gas, we find on the part of many Gas Companies the desire to combine to a greater or less extent an efficient system of making high candle power Water Gas; and with a view of enabling this to be done WITHOUT EXCESSIVE CHARGES FOR PATENT RIGHTS, ETC., we have acquired, by purchase, the exclusive right to construct all the Water Gas Apparatus under the valuable "Wilkinson" Patents.

The results obtained by this Process are far better than those obtained by any other apparatus, especially where an illuminating gas of high candle power or a fuel gas of intense temperature is required.

The Process is uninterrupted, making gas of uniform quality and quantity. Its greatest advantages are maximum production with minimum material and labor, combined with great durability of apparatus.

The Process is in successful operation at the works of the N. Y. Mutual Gas Company, New York; Consolidated Gas Company, Baltimore, Md.; the Hudson County Gas Light Company, of Hoboken, N. J.; and at Rye, N. Y.

We shall be glad to give further detailed information upon application.

Sole Agents for the Celebrated Hazleton Boiler.

BARTLETT, HAYWARD & CO.

EXHAUSTERS.

EXHAUSTERS.

PROCESSES.

THE ROOTS GAS EXHAUSTER.

CINCINNATI, OHIO, March 24, 1887.

P. H. & F. M. Roots, Connersville, Ind.: Gentlemen—I have the honor to say that after the continuous and uninterrupted use of your Exhausters for a period of fifteen years, it affords me pleasure to endorse them in the highest possible terms. Very respectfully,

A. HICKENLOOPER, Prest. Cincinnati Gas Co.

CINCINNATI GAS LIGHT AND COKE CO., Cincinnati, Ohio, two No. 6 Gas Exhausters, with Engine, for their new works, which, with the two No. 6 Exhausters, without Engines, at their old works, and one No. 3, with Engine for pumping, for their station at Carthage, make five Exhausters in all for this Company.

CHICAGO, ILL., March 24, 1887.

Messrs. P. H. & F. M. Roots, Connersville, Ind.: Dear Sirs—We have two of your No. 6 Exhausters at our works, which have been running for several months, and are giving very good satisfaction. Yours truly,

THEO. FORSTALL, Prest.

THE CHICAGO GAS LIGHT AND COKE CO., Chicago, Ill., two No. 6 Gas Exhausters and Engine combined on same bed-plate.

ST. LOUIS, MO., March 21, 1887.

Messrs. P. H. & F. M. Roots, Connersville, Ind.: Dear Sirs—In 1872 one of your No. 5 Exhausters was placed in these works, and worked satisfactorily. March, 1885, it was replaced by one of your No. 6 Exhausters. The latter has been in almost constant use the past two years, has worked up to all my expectations, and is to-day in apparently as good condition as when first set up. It has not cost one cent for repairs in all that time. I have also had one of your No. 1 Exhausters, with Engine on same bed-

P. H. & F. M. ROOTS, Patentees and Manufacturers, CONNERSVILLE, IND.

S. S. TOWNSEND, Gen. Agt., 22 Cortlandt St., N. Y.

plate, fitted with your valves and Huntoon Governor, placed in a small works under my control, and in its operation it seems as near perfection as I ever expect an Exhauster to become. Without in the least disparaging Exhausters of other makes, I may say that your Exhauster may be safely recommended as unsurpassed by any other, to those requiring such machines. Yours respectfully,

FREDERIC EGNER, Eng. and Supt.

CLEVELAND, OHIO, March 22, 1887.

Messrs. P. H. & F. M. Roots, Connersville, Ind.: Gentlemen—Concerning the Exhauster furnished this Company by you last fall, I can say but little—indeed, much need not be said. It simply does its work perfectly, and in a way that inspires confidence that it will not shirk its duty when one's back is turned. If I wanted another 1,000,000 capacity I should try and duplicate our No. 4. Very respectfully,

EDWARD LINDSLEY, Eng. and Supt.

PEOPLES GAS LIGHT CO., Cleveland, Ohio, one No. 4 Exhauster and Engine combined on same bed-plate, Pipe Fittings, Gas and Bye-Pass Valves, Governor, etc.

INDIANAPOLIS, IND., March 21, 1887.

P. H. & F. M. Roots, Connersville, Ind.: Gentlemen—The No. 4 Exhauster and Engine which you erected for us last summer has done all you claimed for it, and has given us perfect satisfaction. Yours very truly,

JAS. SOMERVILLE, Eng. and Supt.

INDIANAPOLIS GAS LIGHT CO., Indianapolis, Ind., one No. 4 Gas Exhauster and Engine combined on same bed-plate, Pipe Fittings, Gas and Bye-Pass Valves, etc. This Exhauster has a capacity of 1,000,000 cu. ft.

COOKE & CO., Selling Agts., 22 Cortlandt St., N. Y.

DURING THE PAST YEAR, THE

NATIONAL GAS LIGHT AND FUEL CO.

218 LA SALLE ST., CHICAGO,

Have Erected Twelve Sets of Water Gas Generating Apparatus under the *Springer Cupola* System. They are as follows:

Newton Illuminating Company, Newton, Kansas.—Daily capacity, 120,000 cu. ft.

Wellington Light & Heat Co., Wellington, Kansas.—Daily capacity, 120,000 cu. ft.

Chippewa Falls, Gas Light Co., Chippewa Falls, Wis.—Daily capacity, 120,000 cu. ft.

Elkhart Gas Light & Coke Co., Elkhart, Indiana.—Daily capacity, 120,000 cu. ft.

Madison City Gas Light Company, Madison, Wis.—Daily capacity, 120,000 cu. ft.

South Bend Gas Light Co., South Bend, Indiana.—Daily capacity, 250,000 cu. ft.

Sheboygan National Gas Comp'y, Sheboygan, Wis.—Daily capacity, 120,000 cu. ft.

Salina Gas Light Company, Salina, Kansas.—Daily capacity, 120,000 cu. ft.

Rathbun Company, Deseronto, Province Ontario.—Daily capacity, 80,000 cu. ft.

Jefferson City Gas Light Co., Jefferson City, Mo.—Daily capacity, 120,000 cu. ft.

Mankato Gas Light Company, Mankato, Minnesota.—Daily capacity, 80,000 cu. ft.

Minneapolis Gas Lt. & Coke Co., Minneapolis, Minn.—Daily capacity, 1,000,000 cu. ft.

1886

1886

CONNELLY & CO., LTD.,

SOLE MANUFACTURERS OF THEIR PATENTED SPECIALTIES.

"IRON SPONGE." Saves money, saves labor, and is the most efficient purifying agent ever offered as a substitute for lime. Now used *in every State in the Union*, and purifying daily over *twenty-five million cubic feet*. Should be used in every gas works. Its own saving will pay for it many times over.

AUTOMATIC GOVERNOR. Has been on the market but *two years*, and in that time has been introduced *more generally* than any invention ever designed for use in gas works. Over *one hundred* of them now in use. Sensitive; reliable; perfectly automatic; reduces leakage; satisfies consumers, and gives great relief to the Manager. No gas works is *complete* without one of these machines.

STEAM JET EXHAUSTER. Designed particularly for small works. Combines Exhaust Tube, Steam Governor, Gas Compensator, and Bye-Pass Valves in the most compact form possible; occupies but little space; uses very little steam; operated by ordinary workmen; saves formation of carbon in retorts; increases yield 10 to 15 per cent. Specially adapted for *mixing air* with oil gas. *No works* too small to use them profitably.

Prices given on all our specialties *delivered at any point in the United States*. Correspondence solicited.

CONNELLY & CO., LTD., No. 177 Broadway, New York City.

WILBRAHAM GAS EXHAUSTER

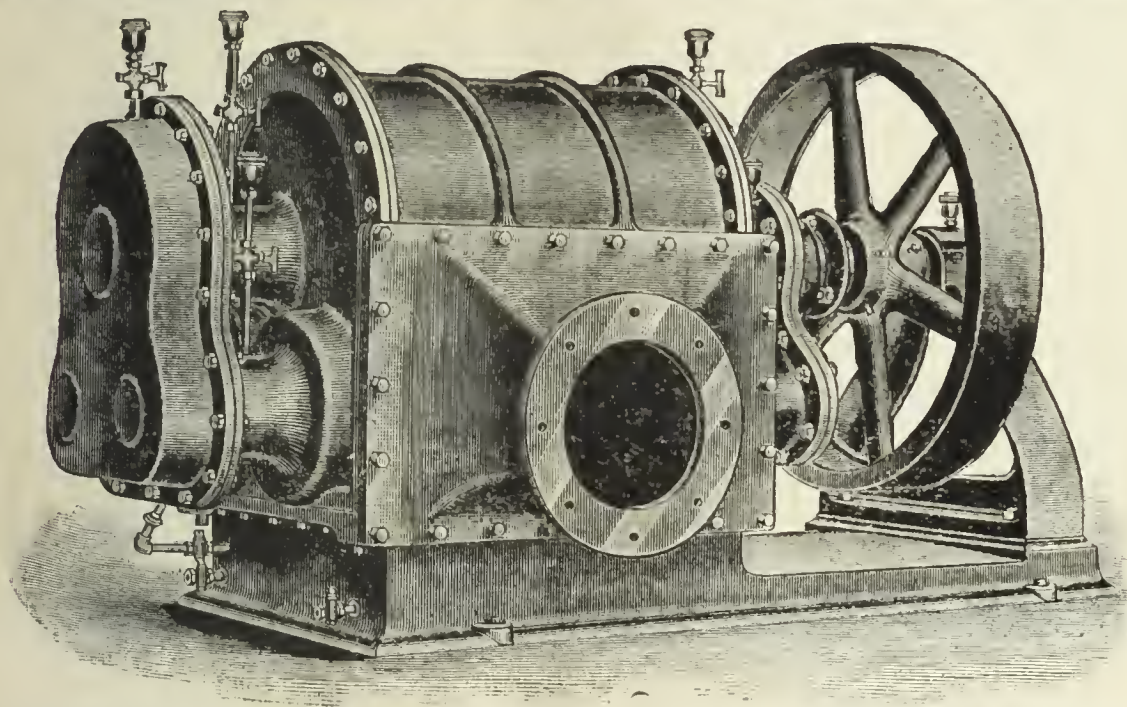

WILBRAHAM BROS.,
PHILADELPHIA, PA.

JARVIS ENGINEERING CO.,

61 Oliver St., Boston, Mass.

CONTRACTORS FOR ERECTING

COMPLETE STEAM OUTFITS FOR ELECTRIC LIGHTING STATIONS.

Steel Boilers set with Jarvis Pat. Boiler Setting,

To burn **COKE SCREENINGS** for Fuel.

ARMINGTON & SIMS CO. ENGINES,

Belted direct to Dynamos, without using Shafting.

SEND FOR CIRCULARS.

REFERENCES - Charlestown Gas & Electric Light Co., Charlestown, Mass.; Schenectady Gas & Electric Light Co., Schenectady, N. Y.; Brookline Gas Co., Brookline, Mass.

Improved Patent
GAS BAG OR
BLADDER VALVE.

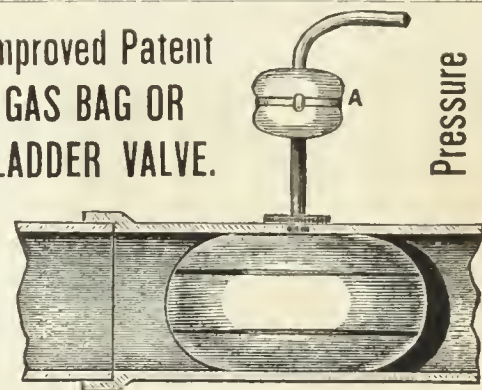

MANUFACTURED BY
PEERLESS MFG. CO., 34 Murray St., N.Y.

THE CLERK GAS ENGINE CO.,

Main Office, 1012, 1014, 1016, 1018 Filbert St., Philadelphia, Pa.

WM. W. GOODWIN, Prest.

E. STEIN, Sec.

S. LEWIS JONES, Asst. Sec.

A. J. DOTY, Supt.

The utility and convenience of the Gas Engine being no longer an open question, it only remains now for intending purchasers to select the BEST. We claim for the CLERK GAS ENGINE that it is equal to any other manufactured as regards steadiness in running, simplicity, and ease of keeping in repair, and that it gives the greatest amount of power for the least money (both in first cost and expense of running) of any engine made. In support of this claim we refer to the test of the Gas Engines made under the direction of the American Institute of New York, in December, 1885, and heretofore published in these columns. These engines are especially adapted for continuous running under heavy loads, and we can refer to Engines which have run 22 hours a day for months at a time.

Made in Sizes of 5, 10, 15, 20, and 25 Horse Power. All Engines Guaranteed for One Year.



CHAPMAN VALVE MANUFACTURING CO., LUDLOW VALVE MFG. CO.

MANUFACTURERS OF

Valves and Gates for Gas, Ammonia, Water, Etc.

Also, Gate Fire Hydrants With and Without Independent Nozzle Valve. All Work Guaranteed.

WORKS & GEN'L OFFICE:
Indian Orchard, Mass.

TREASURER'S OFFICE:
72 Kilby & 112 Milk Sts, Boston, Mass.



OFFICE AND WORKS,
938 to 954 River Street and 67 to 83 Vail Av.
TROY, N. Y.

How to Reduce Leakage to Its Minimum.

USE

HOPPER'S AUTOMATIC DIFFERENTIAL GAS GOVERNOR.

Needs No Attention. Simple, Reliable, Perfectly Automatic.
"Nearly Thirty in Use."

BYE-PASSES, DRY CENTER VALVES, PRESSURE REGISTERS. Also, GOVERNORS FOR STREET MAINS, *NOT DIFFERENTIAL*, and for EXHAUSTERS, GAS ENGINES, etc.

Our new Bye-Pass is threefold in its action—passes gas through, or bye-passes, or shuts off entirely. Correspondence solicited; information given. Send for circulars and testimonials.

T. C. HOPPER & CO., - - No. 227 Wood Street, Philadelphia, Pa.

G. S. COOK, Pres. THOS. DAVENPORT (late Davenport Bros.), Sec. & Treas

BARTLETT

Street Lamp Mfg. Co.

MANUFACTURERS OF

Bartlett's Patent

GLOBE LAMPS.

FOR

Streets, Parks, Railroad Stations, Public Buildings, Etc.

LAMP POSTS A SPECIALTY.

Office and Salesroom

40 & 42 College Place, N. Y. City.

Gas Companies and others intending to erect lamps and posts will do well to communicate with us.

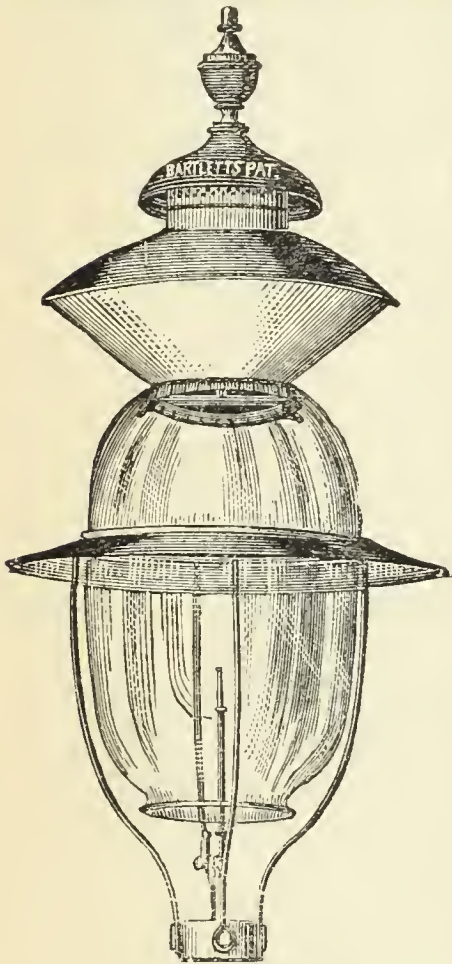

Hydraulic Main Dip Regulators, also Check Valves, Foot Valves, Yard-wash and Fire Hydrants. Send for Circulars.

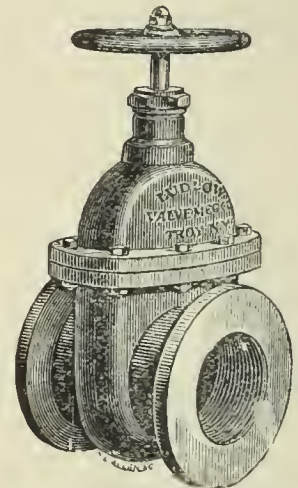

Valves.—Double and Single Gate, 1/2 in. to 48 in., outside and inside Screws. Indicator, etc., for Gas, Water, Steam, and Oil. Send for Circulars.

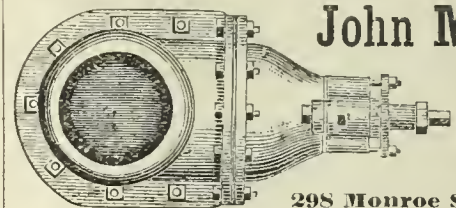

John McLean

Man'facturer of

GAS VALVES.

298 Monroe Street, N. Y.

MITCHELL, VANCE & CO.,

MANUFACTURERS OF

Chandeliers

and every description of

GAS FIXTURES.

Also manufacturers of Fine Gilt Bronzes and Marble Clocks, warranted best time-keepers. Mantel Ornaments, etc.

Salesrooms, 836 Broadway, N. Y.

Special Designs furnished for Gas Fixtures for Churches, Public Halls, Lodges, etc.

GAS AS A SOURCE OF LIGHT, HEAT, AND POWER.

By C. J. R. HUMPHREYS

A Pamphlet of twenty-nine pages, treating of the use of Gas as a source of Light, Heat, and Power.

DESIGNED FOR DISTRIBUTION BY GAS COMPANIES AMONG THEIR CUSTOMERS AND OTHERS.

Price, 10 cents each, \$5 per 100, \$50 per 1,000.

Gas Companies can have their own imprint placed on cover without extra charge. All orders to be sent to

A. M. CALLENDER & CO.,

No. 42 Pine Street, N. Y. City.

GAS STOVES.

GAS STOVES.

GAS STOVES.

THE AMERICAN METER CO.,

MANUFACTORIES,

508 to 514 West Twenty-second St., N. Y.

Arch and Twenty-second St., Phila.

Nos. 244 & 246 North Wells Street, Chicago, Ill.

AGENCIES,

No. 177 Elm Street, Cincinnati, Ohio.

Nos. 122 & 124 Sutter Street, San Francisco Cal.

No. 810 North Second Street, St. Louis, Mo.

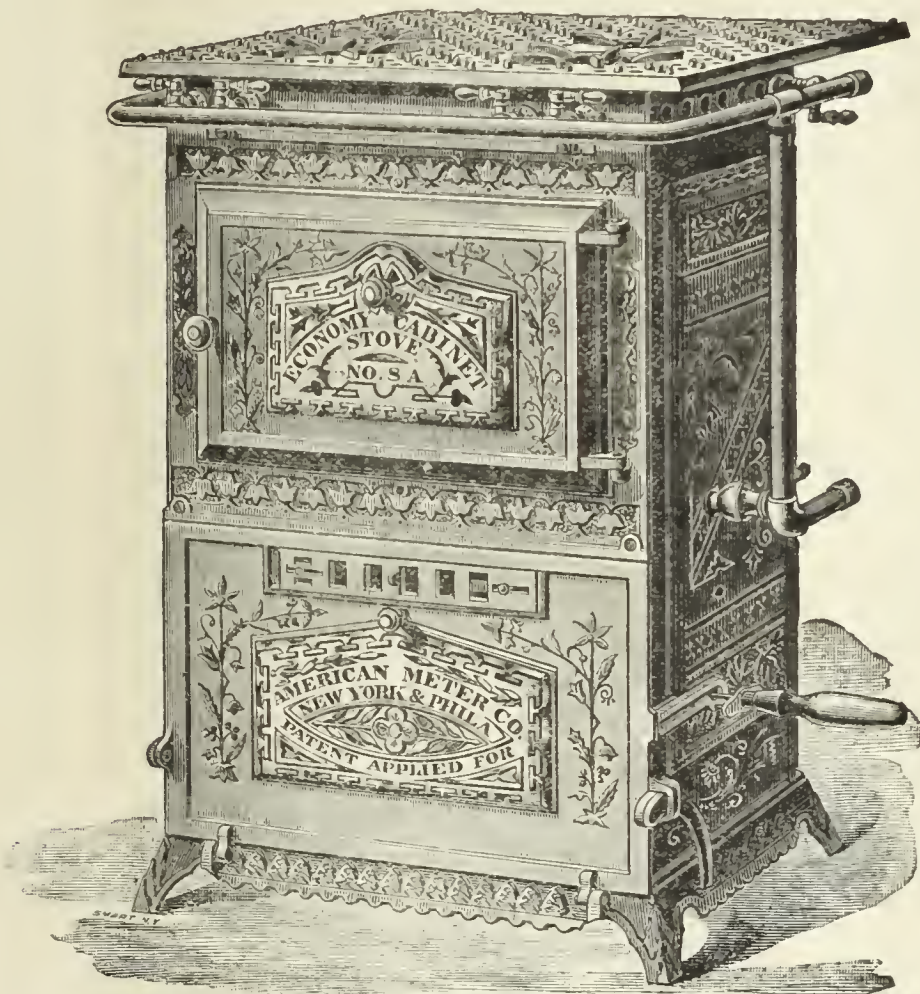

New Design Cast Iron "Economy" Cabinet Stoves.—With Open or Closed Top.

THE COMPANY MANUFACTURES

GAS STOVES FOR COOKING AND HEATING PURPOSES,

In All Sizes, for Domestic, Restaurant, and Hotel Use.

Also,

A Variety of Apparatus for Mechanical Purposes, Using Gas as Fuel.

These Stoves may be seen in operation at our Retail Store, No. 223 Sixth Avenue, N. Y. Call and examine.

SEND FOR ILLUSTRATED CATALOGUE SHOWING THE VARIOUS STYLES AND SIZES.

RETORTS AND FIRE BRICK.

J. H. CAUTIER & CO.,

CORNER OF

GREENE AND ESSEX STREETS,
JERSEY CITY, N. J.

MANUFACTURERS OF

**Clay Gas Retorts,
Gas House Tiles,
Fire Bricks, Etc. Etc.**Ground Clay, Fire Brick and
Fire Sand in Barrels,J. H. GAUTIER.
C. E. GREGORY.T. B. GAUTIER.
C. E. GAUTIER.**BROOKLYN**

Clay Retort & Fire Brick Works,

(EDWARD D. WHITE & CO.)

Manufacturers of Clay Retorts, Fire Brick,
Gas House and other Tile.VAN DYKE, ELIZABETH, RICHARDS & PARTITION STS.
Office, 88 Van Dyke St., Brooklyn, N. Y.

RETORTS AND FIRE BRICK.

LAGLEDE FIRE BRICK MFG. CO.,

MANUFACTURERS OF

Fire Brick, Gas Retorts,

AND

ST. LOUIS STANDARD SEWER PIPE.Blast Furnace and Cupola Linings, every description of Fire
Clay Material, Fire Clay Flue Linings, Chimney Tops
Dry Milled and Crude Fire Clays, etc.

OFFICE AND DEPOT

901, 903, and 905 Pine Street,
ST. LOUIS, MO.

ESTABLISHED IN 1845.

B. KREISCHER & SONS,

OFFICE FOOT OF HOUSTON ST., E.R., N.Y.

Gas Retorts,**TILES, FIRE BRICK.**

AND EVERYTHING IN THE FIRE CLAY LINE.

RETORTS AND FIRE BRICK.

MANHATTAN

FIRE BRICK & ENAMELLED CLAY

RETORT WORKS.**ADAM WEBER.****CLAY GAS RETORTS**

AND RETORT SETTINGS

FIRE BRICKS, TILES, ETC.,

Office and Works, 15th Street and Avenue C., N. Y.

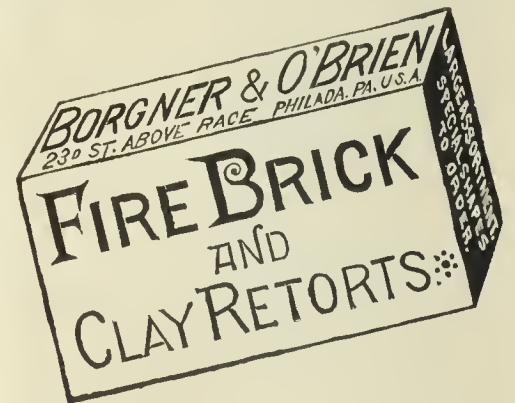

Works,

LOCKPORT STATION, PA.

—ESTABLISHED 1864.—

JAMES GARDNER, JR.,

Successor to WILLIAM GARDNER & SON.

Office, Rooms 19 & 20, Lewis Block,
PITTSBURGH, PA. P. O. Box 373.**Fire Clay Goods for Gas Works.**

CHAS. H. SPRAGUE & SON, No. 70 KILBY STREET, BOSTON, MASS., Agents for the New England States.

OFFICE, 418 to 422 East 23d St., New York.

ESTABLISHED 1856.

WORKS, PERTH AMBOY, NEW JERSEY.

HENRY MAURER & SON,
Excelsior Fire Brick & Clay Retort Works

CLAY GAS RETORTS, BENCH SETTINGS, FIRE BRICK, TILES, ETC.

CHICAGO

Retort & Fire Brick Works,

OFFICE AND FACTORY,
Clark, Forty-Fifth, and La Salle Streets,
CHICAGO, ILL.

GEORGE C. HICKS, PRES. PAUL P. AUSTIN, SEC. & TREAS.

STANDARD

Clay Retorts and Settings.**BLOCKS & TILES**

Of every Shape and Size to Order.

Standard Fire Bricks.**GEROULD'S IMPROVED RETORT CEMENT.**A Cement for patching retorts, putting on mouthpieces, and
making up all bench-work joints. This Cement is mixed ready
or use. Economic and thorough in its work. Fully warranted
stick. For recommendations and price list address**C. L. GEROULD,**
Manchester, N. H.

Western Agent, H. T. GEROULD, Mendota, Ill.

OAKHILL**GAS RETORT & FIRE BRICK**

Works.

Proprietors,

PARKER-RUSSELL MINING & MFG. CO.

City Office, 711 Pine Street,

ST. LOUIS, MO.

Our immense establishment is now employed almost entirely in
the manufacture of**MATERIALS FOR GAS COMPANIES.**We have studied and perfected three important points. Our re-
torts are made to stand changes of temperature, the strongest
heats of the furnace, and the abrasion of feeding and emptying.
Our customers are in almost every State of the Union, to all of
whom we refer.

THOS. SMITH, Prest.

AUGUST LAMBLA, Vice-Prest. & Sup

BALTIMORE**RETORT & FIRE BRICK CO.**

MANUFACTORY AT

LOCUST POINT, BALTIMORE, MD.

Connection with the City by Telephone.

**Clay Retorts, Blocks & Tiles,
FIRE BRICK, FIRE CLAY,
AND FIRE CEMENT.**Red and Buff Ornamental Tiles and Chim-
ney Tops. Drain and Sewer Pipe (from
2 to 30 inches). Baker Oven Tiles
12 x 12 x 2 and 10 x 10 x 2.**WALDO BROS., 88 WATER ST., BOSTON, MASS**

Sole Agents the New England States.

EVENS & HOWARD,
916 Market St., St. Louis. Mo.
Works, Howard Station, Mo. Pacific R.R.

Fire Brick, Gas Retorts
AND
RETORT SETTINGS.

Sewer Pipe, 3 to 24 in. diameter.
Glass Pot Clay, Ground Fire Clay, in barrels and in bulk. All kinds of Fire Clay Goods.

Cincinnati Gas Retort & Fire Brick Works.
—ESTABLISHED 1872.—

CHAS. TAYLOR,
MANUFACTURER OF
Gas Retorts, Fire Brick, and Tile.
Blast Furnace Linings, Cupola Blocks, Boiler Tiles, Grate Settings, and Stove Linings. Fire Cement, Fire Clay, Fire Sand, and all other Fire Clay Goods.

Branch Works, New Cumberland, W. Va.
GENERAL OFFICE AND WORKS,
Burns St., Cincinnati, Ohio.

EMIL LENZ,
2 & 4 Stone St., N. Y. City.
CLAY GAS RETORTS
(ENAMELED.)

Fire Brick, Blocks & Tiles.
FIRE CEMENT, RETORT ENAMEL, RETORT CEMENT, ETC., ETC.

Regenerative and Half-Regenerative Benches.
PORTLAND CEMENT.
Correspondence Respectfully Solicited.

Bouton Foundry Co.,
FOUNDERS AND MACHINISTS,
CHICAGO, ILL.

Gas Works Apparatus,
PURIFIERS, CONDENSERS,
Bench Work,
SPECIALS, LAMP POSTS,
SCRUBBERS,
Iron Roofs and Floors.

Plans and Estimates furnished for new works or extensions of old works.

PATENTS.
FRANKLIN H. HOUGH,
Solicitor of American & Foreign Patents
925 F. ST., WASHINGTON, D. C.
(NEAR U. S. PATENT OFFICE.)

Personal attention given to the preparation and prosecution of applications for Letters Patent. All business before the U. S. Patent Office attended to for moderate fees. No Agency in the United States possesses superior facilities for obtaining Patents, or for ascertaining the patentability of inventions. Copies of patents furnished for 25 cents each. Correspondence solicited.



STEPHEN A. MORSE, President.
GODFREY REBMANN, Vice-Pres.

M. B. DYOTT,
Superintendent.

EDWIN F. MORSE, Secretary.
CARLTON M. WILLIAMS, Treas.

STANDARD GAS LAMP CO.,

Office, 411 Cherry St. Factory, 1101, 1103 & 1105 Frankford Av.
Philadelphia, Pa.

It is to the interest of Gas Companies and Cities to use Dyott's Patent Champion Lamps, which give double the light with the same consumption of gas, and will save 50 per cent. over others in cost of keeping in repair. Gas Companies and others intending to erect Lamps of any description will do well to communicate with us. Special Drawings furnished and Estimates given on application upon Architects', Engineers' or our Draughtsmen's Plans.

Our Patent System of Instantaneously Lighting Gas (without electricity) for R. R. Depots is unequalled. Our High Candle Power Burner is superior to the Electric Light or any other High Candle Burner. We manufacture every description of Ornamental Lamps.

KLOENNE & BREDEL
IMPROVED REGENERATIVE FURNACES.

Self-Sealing Mouthpieces & Bridge-Pipes, Retort Houses,
WASHER-SCRUBBERS,
Gasholders, and Complete Gas Works.

Refers, by permission, to Mr. Eugene Vanderpool, of Newark, N. J.; Mr. E. G. Cowdery, of Milwaukee, Wis.; and Mr. Theo. Forstall, of Chicago, Ill. For further information apply to
FRED. BREDEL, 332 East 17th St., N. Y. City.

CHURCH'S REVERSIBLE TRAY

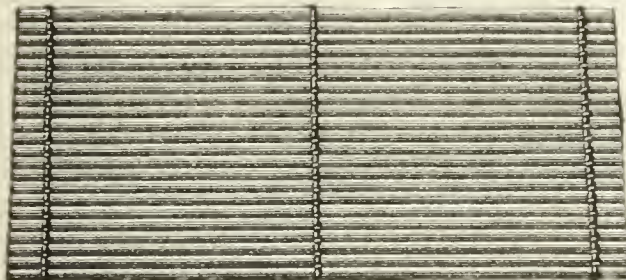

For Purifiers and Scrubbers.
OVAL OR RECTANGULAR SLATS.
FOR LIME OR IRON SPONGE.
MALLEABLE IRON CROSS BARS.
Strongest! Most Durable!
Most Easily Repaired!

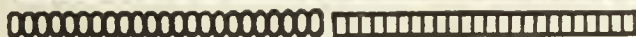

Patented July 9, 1878, and Feb. 5, 1884.
Used by the principal Companies in every State of the Union. Price List on application.

MANUFACTURED BY
JOHN CABOT,
306 to 310 Eleventh Ave., N. Y. City.

MILLS' REVERSIBLE LIME TRAY,

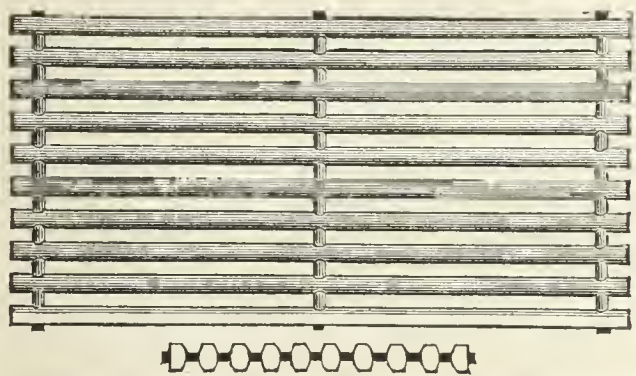

AND
WOODWORK
Of Every Description
NEEDED BY GAS WORKS.

SEND FOR CIRCULAR AND PRICE LIST TO
GEORGE A. MILLS,
Canton Av. & President St., Baltimore, Md.

Ferric Oxide for Gas Purification.

Ferric Oxide, as ground, screened, and prepared by me for purifying purposes, has now been in use for several years by many of the gas works throughout the country, including Detroit, Chicago, Milwaukee, East Saginaw, Burlington (Iowa), Ann Arbor, etc. It has proved, as I believe, the **Most Effective and Economical Agent** now in use. I am prepared to furnish the Oxide by the 100 lbs. or in car load lots, and will be pleased to give price f.o.b. cars at Ann Arbor or at place of destination. Address

S. H. DOUGLAS, Prest. Ann Arbor (Mich.) Gas Light Co.

GAS AND WATER PIPES.

GAS AND WATER PIPES.

ENGINEERS.

SAM'L R. SHIPLEY, Pres.
HENRY B. CHEW, Treas.JAS. P. MICHELLON, Sec.
WM. SEXTON, Supt.**GLOUCESTER IRON WORKS,**
GLOUCESTER CITY, N. J.

Cast Iron Gas & Water Pipes, Stop Valves, Fire Hydrants, Gasholders. &c.
Office No. 6 North Seventh Street, Philadelphia.

MATTHEW ADDY, President.

W. L. DAVIS, Selling Agent.

GEO. P. WILSHIRE, Sec. & Treas.

Cincinnati and Newport Iron and Pipe Company,
NEWPORT, KY.

Lamp Posts

AND

BENCH CASTINGS

A Specialty.

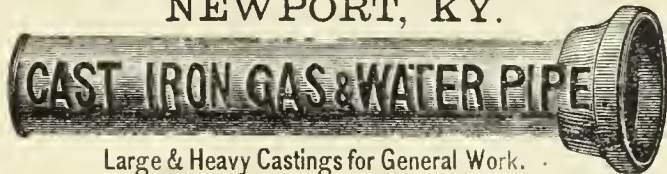

CAST IRON GAS & WATER PIPE

Large & Heavy Castings for General Work.

Branch

AND

SPECIAL CASTINGS

FOR GAS & WATER CO'S.

Manufacture Pipe from 2 to 48 inches. All work guaranteed first quality.

Pancoast & Rogers.**WROUGHT IRON PIPE,**

VALVES AND GATES,

Cast Iron Gas & Water Pipe.

28 Platt and 15 Gold St., New York.

Parson's Steam Blower,FOR IMPROVING BAD DRAUGHT IN BOILERS, AND FOR BURNING BREEZE
OR OTHER WASTE MATERIAL.**PARSON'S TAR BURNER,**

FOR UTILIZING COAL TAR AS FUEL.

PARSON'S AIR JET TUBE CLEANER,

FOR CLEANING BOILER TUBES.

These devices are all first-class. They will be sent to any responsible party for trial. No sale
unless satisfactory. Manufactured by the WATERTOWN STEAM BLOWER COMPANY.**H. E. PARSON. Supt., 42 PINE ST., N. Y.****The Management of Small Gas Works.**

By C. J. R. HUMPHREYS. Price, \$1.

A. M. CALLENDER & CO., 42 Pine St., N. Y.

P. D. WANNER, Chairman. A. H. MELLERT, Sec. & Treas.

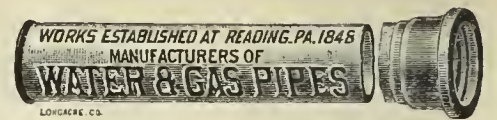
MELLERT FOUNDRY & MACHINE CO., Ltd.
Reading, Pa.Specials—Flange Pipe, Valves and Hydrants,
Lamp Posts, Retorts, etc.

General Foundry and Machine Work.

JOHN FOX, Selling Agent. 160 Broadway, N. Y.

THE OHIO PIPE COMPANY,

MANUFACTURERS OF

Cast Iron Gas & Water Pipe,

BRANCH AND SPECIAL CASTINGS.

Gas-House Bench Castings, Hydraulics, Lamp Posts, Flange Pipe
and Specials, Architectural Castings, Building Columns,
Joists, Cellar Grates, Sash Weights, etc.

GENERAL FOUNDERS AND MACHINISTS.

Columbus, Ohio.

M. J. DRUMMOND,

CAST IRON GAS & WATER PIPE

SPECIAL CASTINGS AND LAMP POSTS.

Equitable Building, 120 Broadway, N. Y.

JOS. R. THOMAS, C.E.,May be Consulted on all Mat-
ters Relating to Gas Works
and Gas Manufacture.

ADDRESS THIS OFFICE.

WM. MOONEY

(Successor to WM. FARMER)

27 Pearl Street, N. Y. City.

(One door from Whitehall Street.)

CONTRACTOR FOR THE ERECTION OF GAS WORKS, OR

APPARATUS OF ANY CAPACITY. AGENT FOR

WM. FARMER'S PATENTS.

Plans and Specifications Furnished.

WM. HENRY WHITE,

CONSULTING AND CONSTRUCTING

Gas Engineer & ContractorEstimates, Plans, and Specifications furnished for new works or
extensions of existing works.

No. 32 Pine Street, New York City.

Correspondence solicited.

WM. GARDNER,**Gas Engineer,**

Lewis Block, Room 20, Pittsburgh, Pa.

Those who intend to make alterations in existing gas plants, or
who contemplate the erection of new works, will find it to their
interest to open correspondence with the above. Plans made
and estimates furnished.

GAS LAMPS.

SCRUBBERS AND CONDENSERS.

The Siemens and Lungren REGENERATIVE GAS LAMPS.

A System of Burning Gas whereby its Illuminating Power is Increased from 300 to 400 per ct. without the Expense, Trouble and Annoyance resulting from the use of Hydrocarbon Enriching Material.

The Siemens-Lungren Company received the only Silver Medal or Highest Award for Gas Burners at the "Novelties" Exhibition of the Franklin Institute, held at Phila., Oct., '85.

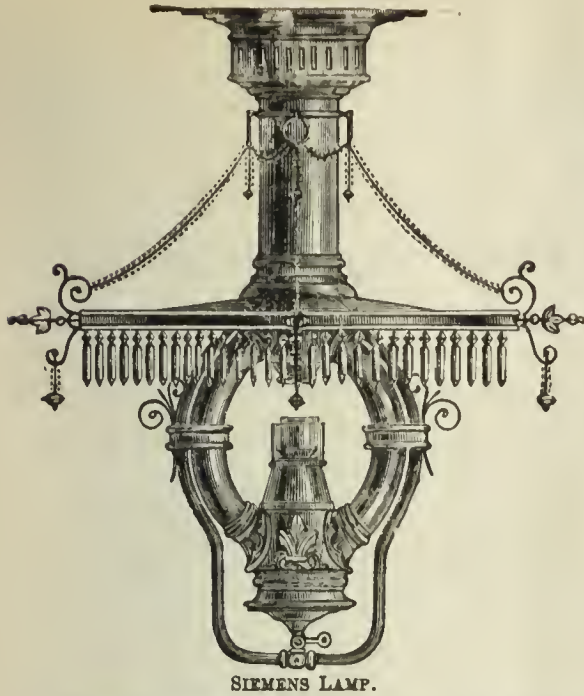

SIEMENS LAMP.

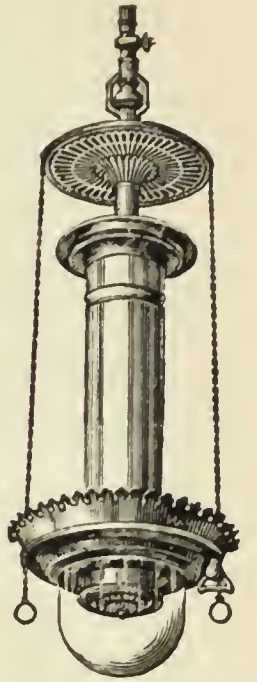

LUNGREN LAMP

THIRTEEN CANDLE POWER PER CUBIC FOOT OF GAS!

This result is obtained

SIMPLY BY THE SCIENTIFIC APPLICATION OF THE REGENERATIVE PRINCIPLE.

Consequently this largely increased illumination is always maintained without further cost and frequent attention.

THE SIEMENS-LUNCREN COMPANY,

N. E. Cor. 21st. St. and Washington Av., Phila., Pa.

THE PATENT "STANDARD" WASHER-SCRUBBER

(KIRKHAM, HULETT & CHANDLER PATENT.)

Has been adopted by gas companies in all parts of the world. Between 300 and 400 companies, with the enormous daily output of over 300,000,000 cubic feet, are now using it. "Standard" Washer-Scrubbers have been erected for the following gas light companies since Jan. 1, 1886:

WALLASEY, ENGLAND.....	750,000 cubic feet.	RICHMOND, SURREY, ENGLAND.....	1,500,000 cubic feet.
NEWARK, ENGLAND.....	350,000 "	BRIDGEPORT, U. S.....	500,000 "
BUFFALO, U. S. (MUTUAL).....	500,000 "	TORONTO, CANADA.....	1,000,000 "
BERLIN, GERMANY.....	1,250,000 "	HARTFORD, U. S.....	1,000,000 "
SO. BRISBANE, AUSTRALIA.....	300,000 "	DETROIT, U. S.....	750,000 "
LEEDS, ENGLAND.....	2,000,000 "	SINGAPORE, CEYLON.....	300,000 "
FURTH, GERMANY.....	400,000 "	BRUNSWICK, GERMANY.....	300,000 "
FREIBURG, GERMANY.....	200,000 "	LILLE, FRANCE.....	750,000 "
NINE ELMS, LONDON.....	3,000,000 "	CADIZ, SPAIN.....	300,000 "
MELBOURNE, AUSTRALIA (2).....	3,000,000 "	READING, ENGLAND.....	2,000,000 "
GLUCKAUF COKE WORKS, GERMANY.	200,000 "	LINCOLN, U. S.....	250,000 "
BOURNEMOUTH, ENGLAND.....	1,000,000 "	ST. LOUIS, U. S. (LACLEDE).....	1,000,000 "
		BROOKLYN, U. S.....	2,000,000 "
		BROOKLYN, U. S. (NASSAU).....	1,000,000 "
		DENVER, U. S.....	1,000,000 "

That this apparatus is really the *standard* is indicated by the following names of important houses who represent this invention in the different countries of the world:

FRANCE & BELGIUM, Mons. J. A. Berly, 31 Rue Boiod, Paris. HOLLAND & DUTCH COLONIES, Mess. W. Hoven & Zoon, Rotterdam.

GERMANY and AUSTRO-HUNGARY, Berlin-Anhaltische-Actiengesellschaft, Berlin, Moabit, and Dessau.

RUSSIA, Mr. F. Bley, Galernaya, 44, St. Petersburg. SPAIN, Mess. Nicolas, Chamon, Foiret & Cie., 29 Rue Claude-Vellefaux, Paris.

ITALY & MALTA, Sig. E. Canziani, 26 & 28 Portici, Vittorio Emmanuele, Genoa. Sig. Fratelli Scheuer, Via Chiaja, 124, Naples

NEW SOUTH WALES, Messrs. W. Coward & Sons, 143 Queen Victoria St., London.

NEW ZEALAND and VICTORIA, Messrs. G. D. Jennings & Co., 28 Gracechurch St., London.

Companies in the U. S. adopting this apparatus can now be assured of a market for the Ammoniacal Liquor at a remunerative price. Correspondence for purchase of "Standards" and Ammoniacal Liquor is solicited by the

GEO. SHEPARD PAGE, 69 WALL STREET, NEW YORK.

GAS WORKS APPARATUS AND CONSTRUCTION.

GAS WORKS APPARATUS AND CONSTRUCTION.

WORKS: { MILLVILLE, N. J.
FLORENCE, "
CAMDEN, "

R. D. WOOD & CO.,

OFFICES: { 400 CHESTNUT ST.,
PHILADELPHIA.

CAST-IRON PIPE 1½ to 72 Inches in Diameter.

Water Machinery and Gas Apparatus.

HEAVY CASTINGS.

HOLDERS,

PURIFIERS,

FLOORS AND ROOFS,

LAMP POSTS,

CONDENSERS,

FLANGED PIPE,

VALVES,

BENCH WORK,

FIRE HYDRANTS,

METER CASES.

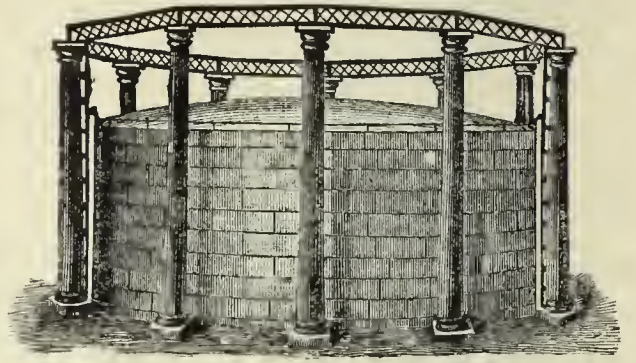
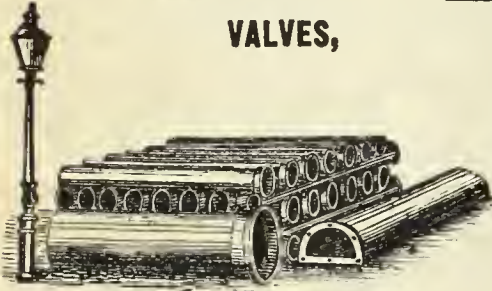

Estimates and Specifications for
NEW WORKS or **EXTENSIONS**
or **ALTERATIONS** of **OLD ONES.**

SOUTHWARK FOUNDRY AND MACHINE COMPANY,

Successors to MERRICK & SONS,

GAS APPARATUS,

HOLDERS, Purifiers, Washers, Etc., Etc. Boiler and Tank Work. Steam Engines.
Hydraulic Machinery. Bessemer Plants, Etc.

Washington Ave. and Fifth Street, Philadelphia, Pa.

MORRIS, TASKER & CO.,

Limited,

Builders of Gas Works,

PHILADELPHIA PA.

GASHOLDERS, PURIFIERS, SCRUBBERS, CONDENSERS, EXHAUSTERS,

Bench Castings, Iron Roofs, Lamp Posts,

VALVES, STREET MAIN SPECIALS, ETC.,

MANUFACTURED BY

KERR MURRAY MANUFACTURING COMPANY.

From 1880 to 1886, inclusive, we erected Gasholders for the following cities, viz.:

Adrian, Mich.	East End Gas Co., Pitts-	Janesville, Wis.	New Castle, Pa.	Valparaiso, Ind.
Akron, Ohio.	burgh, Pa.	Johnstown, Pa.	Niagara Falls, N. Y.	Van Wert, Ohio.
Albuquerque, N. M.	East Saginaw, Mich.	Key West, Fla.	Osawatomie, Kans.	Wabash, Ind.
Altoona, Pa.	Elgin, Ills.	La Crosse, Wis.	Pittsburgh, Pa. (2)	Waco, Texas.
Anderson, Ind.	Evanston, Ills.	Lebanon, Ind.	Plainfield, Ind.	Waukesha, Wis.
Bellaire, Ohio.	Eufaula, Ala.	Lima, Ohio.	Portage City, Wis.	Wheeling, West Va.
Birmingham, Ala.	Frankfort, Ind.	Logan, Ohio.	Sedalia, Mo.	Wellington, Kans.
Bucyrus, Ohio.	Freeport, Ills.	Louisville, Ky.	Sheboygan, Wis.	West Pittsburgh, Pa.
Canton, Ohio.	Galesburg, Ills.	Mankato, Minn.	South Bend, Ind.	Xenia, Ohio.
Circleville, Ohio.	Grafton, West Va.	Mansfield, Ohio.	South Chicago, Ills.	Youngstown, Ohio.
Colorado Springs, Col.	Greensburg, Pa.	Marshalltown, Iowa.	Springfield, Ills.	Ypsilanti, Mich.
Danbury, Conn.	Huntington, Ind. (2)	Meridian, Miss.	Streator, Ills.	
Delaware, Ohio.	Ironton, Ohio.	Minneapolis, Minn.	Topeka, Kans.	
Delphos, Ohio.	Jamestown, N. Y.	Muskegon, Mich.	Uniontown, Pa.	

Under construction, 1887.

Arkansas City, Kans.	Grand Forks, Dakota.	Mobile, Ala.	Santa Fe, N. M.	Fuel Gas and Electric Engi-
Dallas, Texas.	Grand Rapids, Mich.	Pittsburgh, Pa.	Wichita, Kans.	neering Co., Pittsburgh, Pa.
El Paso, Texas.	La Crosse, Wis.	Pine Bluff, Ark.	Lexington, Mo.	Stillwater, Minn.

Estimates, with Plans and Specifications, for new or the rebuilding of old works, furnished on application. Correspondence solicited. Address

KERR MURRAY MANUFACTURING CO.,

A. D. CRESSLER, General Manager.

FORT WAYNE, IND.

GAS WORKS APPARATUS AND CONSTRUCTION.

GAS WORKS APPARATUS AND CONSTRUCTION.

JAMES R. FLOYD,

(SUCCESSOR TO HERRING & FLOYD)

Oregon Iron Works,

531 to 543 West 20th St., N. Y.

Practical Builders of Gas Works,

MANUFACTURERS OF

**ALL KINDS OF CASTINGS
AND
APPARATUS FOR GAS-WORKS.**

BENCH CASTINGS

from benches of one to six Retorts each.

**WASHERS: MULTITUBULAR AND
AIR CONDENSERS; CONDENSERS;
SCRUBBERS**

(wet and dry), and

EXHAUSTERS

for relieving Retorts from pressure.

BENDS and BRANCHES

all sizes and description.

FLOYD'S PATENT

MALLEABLE RETORT LID.

PATENT

SELF-SEALING RETORT LIDS.

FARMER'S

PATENT BYE-PASS DIP-PIPE.

SABBATON'S PATENT

FURNACE DOOR AND FRAME

BUTLER'S

COKE SCREENING SHOVELS.

GAS GOVERNORS,

and everything connected with well regulated Gas Works at low price, and in complete order.

SELLER'S CEMENT

for stopping leaks in Retorts.

N. B.—STOP VALVES from three to thirty inches—at very low prices.

Plans, Specifications, and Estimates furnished.

THE CONTINENTAL IRON WORKS.

THOS. F. ROWLAND, Prest. WARREN E. HILL and CHAS. H. CORBETT, V.-Prests. THOS. F. ROWLAND, JR., Sec. & Treas.



GAS HOLDERS OF ANY MAGNITUDE.

P. O. Station G., BROOKLYN, N. Y.

ENGINEERS AND MANUFACTURERS OF

Gas Holders

CONDENSERS, SCRUBBERS, VALVES,

PURIFIERS, SELF-SEALING RETORT LIDS,

Hydraulic Mains,

And all other articles connected with the manufacture and distribution of Gas.

H. RANSHAW, Prest. & Mangr. WM. STACEY, Vice-Prest. T. H. BIRCH, Asst. Mangr. R. J. TARVIN, Sec. & Treas.

STACEY MFG. CO.,

MANUFACTURERS OF

Single and Telescopic Gasholders,

IRON ROOFS, BRIDGES, LAMP POSTS,

Water and Oil Tanks, Coal Elevator Cars,

COKE CRUSHERS, BENCH CASTINGS,

And all kinds of Wrought and Cast Iron Work used in the erection of Coal and Oil Gas Works. Rolling Mill Machinery and Heavy Castings a Specialty.

Foundry:

33, 35, 37 & 39 Mill Street.

Wrought Iron Works:

16, 18, 20, 22, 24 & 26 Ramsey Street.

Cincinnati, Ohio.

1842. DEILY & FOWLER, 1887.

Laurel Iron Works.

Address, No. 39 Laurel Street, Philadelphia, Pa.

MANUFACTURERS OF

GASHOLDERS,

Single or Telescopic, with Cast or Wrought Iron Guide Frames.

HOLDERS BUILT SINCE 1881:

- | | | | | |
|-----------------------|---------------------------|---------------------------|----------------------------|----------------------------|
| Scranton, Pa. (2d) | Holidaysburg, Pa. | Jackson, Mich. | Montgomery, Ala. | New Castle, Pa. |
| West Point, N. Y. | Galveston, Texas (2d.) | Kalamazoo, Mich. (3d.) | Newport, R. I. | Long Island City, N. Y. |
| Fitchburgh, Mass. | Marlboro, Mass. | Glen Island, N. Y. | Portland, Oregon. | Macon, Ga. |
| New London, Conn. | Denver, Col. | Warren, Ohio. | Allegheny, Pa. (2d.) | York, Pa. |
| Derby, Conn. | Chicago, Ill. (West Side) | Bath, N. Y. | Atlanta, Ga. (2d.) | Chester, Pa. |
| Bridgeport, Conn. | Pittsburgh, Pa. (S. Side) | Lynn, Mass. | N.Y. City (Central Gas Co) | Hazleton, Pa. 2d.) |
| Allegheny, Pa. (1st.) | Pawtucket, R. I. | New Bedford, Mass. | Lynchburg, Va. (2d.) | Novelties Exhib., Phila |
| St. Hyacinth, Can. | Brookline, Mass. | Waterbury, Conn. | Saylesville, R. I. | Stateo Island, N. Y. |
| Norwalk, O. | Sherbrooke, Can. | Deserono, Can. | Rondout, N. Y. | Saugerties, N. Y. |
| Brattleboro, V | Burlington, N. J. (2d.) | Hoosic Falls, N. Y. (2d.) | Atlantic City, N. J. | Clinton, Mass. (Lan. Mills |
| Waltham, Mass. (2d.) | Bridgeton, N. J. | Bethlenem, Pa. | Augusta, Ga. | Chattanooga, Tenn. |
| West Chester, Pa. | Bay City, Mich. | Atlanta, Ga. (1st.) | Waltham, Mass. (2); | Galveston, Texas. (3d.) |
| Baltimore, Md. | Erie, Pa. | Savannah, Ga. | Mahanoy Citv. Pa. | Omaha, Neb. |

GAS vs. ELECTRIC LIGHT.

We would invite attention to the able and exhaustive argument of General A. Hickenlooper, President of the Cincinnati Gas Light and Coke Company, contained in a handsome pamphlet of 96 pages, entitled

"EDISON'S INCANDESCENT ELECTRIC LIGHTS FOR STREET ILLUMINATION. REPORT OF AN ARGUMENT DELIVERED BY A. HICKENLOOPER BEFORE THE COMMITTEE ON LIGHT, MUNICIPAL COUNCIL, CITY OF CINCINNATI, JULY 22, 1886."

This is a subject of special interest to all Gas Light Companies.

Prices.

25 copies..... \$7.50 100 copies..... \$22.50
50 copies..... 12.50 250 copies..... 50.00

A sample copy will be sent by mail on receipt of 50 cts.

A. M. CALLENDER, & CO., 42 PINE ST., N. Y. CITY.

SMITH & SAYRE MFG. COMPANY,

G. PORTER, Prest.

245 Broadway, N. Y.

CHAS. W. ISBELL, Sec'y.

Machinery & Apparatus for Gas Works

Drawings, Plans, and Estimates Furnished for the Improvement, Extension, or Alteration of Gas Works, or for the Construction of New Works.

Mackenzie's Patent Rotary and Steam Jet Gas Exhausters, Governors, Compensators, Condensers, Washers, Scrubbers. Isbell's Patent Automatic Street Pressure Governor, Gas and Water Valves, Hydraulic Main Dip Regulator, Bench Castings, etc. Purifying Boxes and "Standard" Scrubbers. Isbell's Patent Self-Sealing Retort Doors.

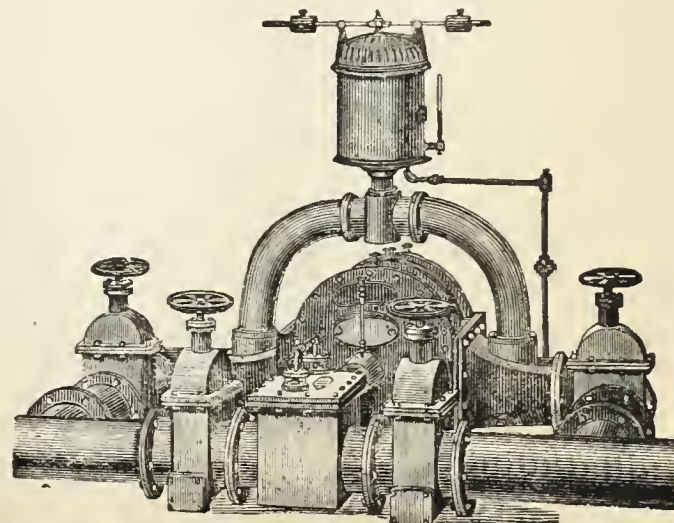

GAS COALS.

CANNEL COALS.

GAS ENRICHERS.

JAMES D. PERKINS.

PERKINS & CO.,

F. SEAVERNS.

General Sales Agents for

The Youghioghenny River Coal Company's

OCEAN MINE YOUGHIOGHENY GAS COAL.

The Coal from the Ocean Mine (recently operated by *Messrs. W. L. Scott & Co.*, of Erie, Pa.,) is now used by all the leading Gas Companies in the United States from Maine to Texas, and is recognized as *the only reliable Youghioghenny Gas Coal.* (See Map on p. 87 of this Journal, Feb. 16, '85.)

P. O. Box 3695,
New York.

PERKINS & CO., 228 and 229 N. Y. Produce Exchange.

BEAVER STREET
ENTRANCE.

BRECKENRIDGE CANNEL, OF KENTUCKY.

This Colliery was re-opened in June, 1886, since which date the Cannel has been delivered to over sixty of the leading Gas Companies in this country and in Europe. As an enricher ONE TON of this Cannel will do the work of two TONS of any other available Cannel, and is more economical than Naptha or Oil of any character. It can be delivered in parcels of one car load or more to any point in the United States or Canada.

(See AMERICAN GAS LIGHT JOURNAL, June 16, '86, pp. 346-7.)

P. O. Box 3695,
New York.

PERKINS & CO., 228 and 229 N. Y. Produce Exchange

BEAVER STREET
ENTRANCE.

JAMES & WILLIAM WOOD, Gas and Cannel Coal Contractors,

No. 40 St. Enoch Sq., Glasgow. No. 2 Talbot Court, London.

Proprietors of the BATHVILLE COLLIERIES (which produce the celebrated BOGHEAD CANNEL), Shields, Shieldmuir, Drumpeller, and other Collieries. This Firm offer

STANDARD CANNELS,

Unequaled as Gas Enrichers.

Analyses, prices, and all further information furnished on application to

Agency for U. S., Room 93, Nos. 2 & 4 Stone St., N.Y. City.

The Standard Oil Company,

REFINERS OF

NAPTHA AND GASOLINES.

ALSO MANUFACTURERS OF

A Special Grade of Naptha for Gas Companies

FOR ENRICHING COAL GAS.

Correspondence solicited.

No. 43 Euclid Avenue, Cleveland, Ohio.

To Gas Companies.

We make to order CAP BURNERS to burn any amount under a stated pressure. Send for samples.

Also, SERVICE CLEANERS, DRIP PUMPS, and STREET MAIN PROVING APPARATUS.

C. A. GEFROERER,

248 N. 8th Street, Phila., Pa.

GOODWIN'S DIRECTORY

OF THE GAS LIGHT COMPANIES of the UNITED STATES & CANADA.

Price, \$10.00.

Orders may be sent to

A. M. CALLENDER & CO., No. 42 Pine Street, N. Y. City.

COKE CRUSHERS.

GAS COALS.

GAS COALS.

Newburgh Orrel Coal and Coke Co.

MINERS AND SHIPPERS OF

Mountain Brook Steam and Smithing Coals,

**NEWBURGH, PALATINE,
AURORA & TYRCONNELL
GAS COALS.**

Foundry & Crushed Coke Shipped Direct from Ovens
Mines Situated at
Newburgh, Flemington & Fairmont, W.Va.

HOME OFFICE,

33 S. Gay St., Baltimore.

CHAS. MACKALL, Gen. Mangr.

CHAS. W. HAYS, Agent in New York,

Room 147, WASHINGTON BUILDING, No. 1 Broadway.

Shipping wharves at Locust Point, Baltimore.

THE DESPARD COAL COMPANY

OFFER THEIR SUPERIOR

DESPARD COAL

To Gas Light Companies and Manufacturers of Fire Clay Goods
Throughout the Country.

ROUSSEL & HICKS, } AGENTS. { BANGS & HORTON,
71 Broadway, N. Y. } 16 Kilby St., Boston.

Mines in Harrison Co., West Va. Wharves, Locust Point, Balt.

Company's Office, 15 German St., Baltimore, Md.

Among the consumers of Despard Coal we name: Manhattan
Gas Light Co., N. Y.; Metropolitan Gas Light Co., N. Y.; Jersey
City, (N. J.) Gas Light Co.; Washington (D. C.) Gas Light Co.;
Portland (Maine) Gas Light Co. Reference to them is requested.

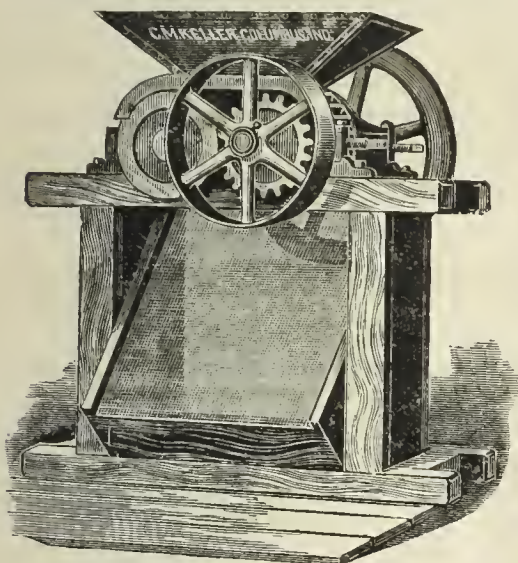

Keller's Adjustable Coke Crusher.

SIMPLE, STRONG, AND DURABLE.

C. M. Keller, Sec. & Supt. Gas Lt. & Coke Co. Columbus, Ind.

Correspondence Solicited.

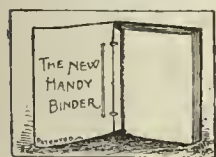

**THE NEW
HANDY BINDER.**

This article may be described as elegant
in appearance, strong, durable, and possessing many special
qualities of its own. It allows the opening of the pages per-
fectly flat, whether one or several numbers are in the binder.
Any number can be taken out and replaced without disturbing
the others. The papers are not mutilated for subsequent bind-
ing in permanent form. The binder is supplied with gilt side
title, and is an ornament to any desk or reading table. The
JOURNAL, filed in the Handy Binder, becomes a volume of great
value, always convenient for instant reference. Handy Binder,
Postage paid, \$1.00.

A. M. CALLENDER & CO., 43 Pine St., N. Y.

**THE
PENN GAS COAL CO.**

OFFER THEIR

Coal, Carefully Screened & Prepared for Gas Purposes.

Their Property is located in the Youghiogheny Coal Basin, near Irwin and Penn Stations on the
Pennsylvania Railroad, and on the Youghiogheny River.

Principal Office:

209 SOUTH THIRD STREET, PHILA., PA.

Points of Shipment:

Pennsylvania Railroad Piers; Greenwich Wharves, Delaware
River; Pier No. 1 (Lower Side), South Amboy, N. J.

Chesapeake & Ohio Railway Coal Agency,

FOR THE SALE OF THE

**Superior Kanawha Gas Coals, Cannelton Cannel,
Also, SPLINT AND STEAM COALS,**

From the Kanawha and New River Regions, on the line of the Chesapeake & Ohio R'way.

C. B. ORCUTT, Sales Agent. | OFFICE, 150 BROADWAY, N. Y.

FRANCIS H. JACKSON, Prest. EDMUND H. MCCULLOUGH, V.-Prest. CHAS. F. GODSHALL, Treas. H. C. ADAMS, Sec.

THE WESTMORELAND COAL CO.

Chartered 1854.

Mines situated on the Pennsylvania and the Baltimore
and Ohio Railroads, in Westmoreland County, Penn.

POINTS OF SHIPMENT:

PHILADELPHIA, BALTIMORE, SOUTH AMBOY, N. J.,
WATKINS (SENECA LAKE), N. Y.

Since the commencement of operations by this Company its well-known
Coal has been largely used by the Gas Companies of New England and the
Middle States, and its character is established as having no superior in gas
giving qualities, and in freedom from sulphur and other impurities.

Principal Office, 224 South 3d St., Phila., Pa.

A. M. SCOTT, PRESIDENT.

A. DEMPSTER, C.E., SECRETARY.

W. K. GILLESPIE, TREASURER.

MONONGAHELA AND PETERS CREEK GAS COAL CO.,

PRODUCERS OF

Coal Bluff Gas Coal.

MINES LOCATED ON THE MONONGAHELA DIVISION OF THE PENNSYLVANIA RR.,
IN THE CENTRAL PORTION OF THE PITTSBURGH COAL FIELD.

Points of Shipment—Buffalo, Cleveland, Erie, Chicago, New Orleans.

Since the introduction of Coal Bluff Gas Coal it has taken rank among the few first-class Gas Coals, and ac-
knowledges no superior in gas-giving qualities, ease of working, quality of coke, and freedom from impurities.

Milwaukee Agents, F. R. BUELL & CO., - - - Milwaukee, Wis.

General Office, 43 Sixth Ave., Pittsburgh, Pa.

GAS METERS.

GAS METERS.

GAS METERS.



INTERNATIONAL--1876--EXHIBITION.

The U. S. Centennial Commission

HAVE DECREED AN AWARD TO

HARRIS, GRIFFIN & CO.,

Twelfth and Brown Streets, Philadelphia, Pa. No. 49 Dey Street, N. Y. City, and No. 75 North Clinton Street, Chicago, Ill.

FOR THE FOLLOWING REASONS :

The Exhibit consists of a Series of METERS from the Largest Size Station Meters for the use of the MANUFACTURE OF GAS, to those for the use of the ORDINARY CONSUMER. The Instruments are WELL MADE, RELIABLE as to INDICATION, and embody a number of sundry improvements which, with the general character of the Exhibit, entitle the whole to commendation.

Attest—J. L. CAMPBELL,
Secretary, pro-tem

Signed—A. T. GOSHORN,
Director General

J. R. HAWLEY,
President

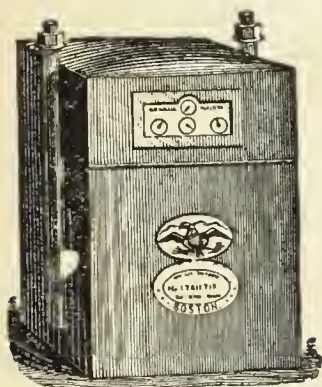

Dry Gas Meter.

With 39 years' experience and the best facilities for manufacturing, is enabled to furnish reliable work and answer orders promptly.

NATHANIEL TUFTS,

No. 153 Franklin Street, Boston, Mass.,

MANUFACTURER OF

DRY GAS METERS.

Station Meters of any Capacity.

Test and Experimental Meters, Pressure Registers, Pressure Gauges, Pressure and Vacuum Gauges.

METER PROVERS, PHOTOMETERS, STREET LANTERNS, ETC., ETC.

Patent Cluster Lanterns for Street Illumination.

SCIENTIFIC BOOKS.

We are prepared to furnish to Gas Managers, and others interested in the topics treated of, the following books, at prices named :

KING'S TREATISE ON THE MANUFACTURE OF COAL GAS. Three vols.; \$10 per vol.

GAS MANUFACTURE, by WILLIAM RICHARDS. 4to., with numerous Engravings and Plates, in Cloth binding. \$12.

THE GAS ANALYST'S MANUAL, by F. W. HARTLEY. \$2.50. TECHNICAL GAS ANALYSIS. \$2.80.

GAS MANAGER'S HANDBOOK, by THOS. NEWBIGGING. \$4.80.

GAS CONSUMER'S GUIDE. \$1.

A GUIDE TO GAS LIGHTING. 40 cents.

GAS MEASUREMENT AND GAS METER TESTING, by F. W. HARTLEY. \$1.60

GAS CONSUMER'S HANDBOOK, by WILLIAM RICHARDS, C.E.; 18mo., Sewed. 20 cents.

A PRACTICAL TREATISE ON GAS AND VENTILATION with Special Relation to Illuminating, Heating, and Cooking by Gas, by E. E. PERKINS. \$1.25.

PRACTICAL TREATISE ON HEAT, by THOMAS BOX. Second edition. \$5.

GAS WORKS—THEIR ARRANGEMENT, CONSTRUCTION, PLANT, AND MACHINERY. \$8.

COAL; ITS HISTORY AND USE, by PROF. THORPE. \$3.50.

THE GAS WORKS OF LONDON, by COLBURN. 60 cents.

THE GAS FITTER'S GUIDE, Showing the Principles and Practice of Lighting with Coal Gas, by JOHN ELDRIDGE. 40 cents.

GAS WORKS, AND MANUFACTURING COAL GAS, HUGHES. \$2.20.

THE MANAGEMENT OF SMALL GAS WORKS, by C. J. R. HUMPHREYS. \$1.

MANUAL FOR GAS ENGINEERING STUDENTS, by D. LEE, 40 cents.

HOW TO MANAGE GAS, by F. WILKINS. Paper. 20 cents.

THE GAS MANAGER IN THE LABORATORY, by a Practica Student. 8vo., Cloth. \$1.50.

THE DOMESTIC USES OF COAL GAS, AS APPLIED TO LIGHTING, by W. SUGG. \$1.40.

DISTILLATION OF COAL TAR AND AMMONIACAL LIQUOR by GEO. LUNGE. \$8.50.

A TREATISE ON THE COMPARATIVE COMMERCIAL VALUES OF GAS COALS AND CANNELS, by D. A. GRAHAM 8vo., Cloth. \$3.

GAS AS A SOURCE OF LIGHT, HEAT, AND POWER, by C. J. R. HUMPHREYS. 10 cents.

GAS COMPANIES DIRECTORY. \$10.

GAS VERSUS ELECTRIC LIGHT. 50 cents.

PURIFICATION OF COAL GAS, by R. P. SPICE. 8vo. \$3.

The above will be forwarded by express, upon receipt of price. We take especial pains in securing and forwarding any other Works that may be desired, upon receipt of order. All remittances should be made by check, draft, or post office money order.

A. M. CALLENDER & CO., No. 42 Pine Street, New York.

KING'S TREATISE ON COAL GAS.

The most complete work on Coal Gas ever published. Three vols., bound \$35.

A. M. CALLENDER & CO., No. 42 Pine Street, New York,

GAS METERS.

GAS METERS.

GAS METERS.

GEO. J. MoGOURKEY, Pres. WM. H. MoFADDEN, Vice-Pres. (Phila.) WM. N. MILSTED, Gen. Supt. & Treas. (New York). WM. H. DOWN Sec.

AMERICAN METER COMPANY,

WET AND DRY GAS METERS. STATION METERS. EXHAUSTER GOVERNORS. DRY CENTRE VALVES. GOVERNORS FOR GAS WORKS.

PRESSURE REGISTERS. PRESSURE & VACUUM REGISTERS. PRESSURE & VACUUM GAUGES. CRESSON GAS REGULATORS. MARSLAND WATER METERS.

METER PROVERS. PORTABLE TEST METERS. EXPERIMENTAL METERS. AMMONIA TEST METERS. BAR AND JET PHOTOMETERS.

Manufactories:
 512 W. 22d St., N. Y. }
 Arch & 22d Sts., Phila. }

GAS STOVES,
 SUGG'S "STANDARD" ARGAND BURNERS,
 SUGG'S ILLUMINATING POWER METER,
 Wet Meters, with Lizar's "Invariable Measuring" Drum.

Agencies:
 177 Elm Street, Cincinnati.
 244 & 246 N. Wells Street, Chicago.
 810 North Second Street, St. Louis.
 122 & 124 Sutter St., San Francisco.

HELME & McILHENNY,

(Successors to Harris & Brother. Established 1848.)

GAS METER MANUFACTURERS,

CONTINUE AS HERETOFORE AT THE OLD ESTABLISHMENT.

Nos. 1339 to 1349 Cherry Street, Philadelphia, Pa.,

To Manufacture Wet and Dry Gas Meters, Station Meters, Experimental Meters, Meter Provers, Center Seals, Pressure Registers
GOVERNORS, INDICATORS, PHOTOMETERS, & ALL OTHER KINDS OF APPARATUS FOR USE IN GAS WORKS.

From our long practical experience of the business, and from our personal supervision of all work, we can guarantee all orders to be executed promptly and in every respect satisfactorily.

WM. WALLACE GOODWIN, Prest. and Treas. WM. H. MERRICK, V.-Prest. S. L. JONES, Sec. S. V. MERRICK, Supt.

THE GOODWIN GAS STOVE AND METER COMPANY,

Successors to W. W. GOODWIN & CO.

1012, 1014 and 1016 Filbert St., Phila., Pa. 142 Chambers St., New York.
 76 Dearborn St., Chicago, Ill.

WALDO BROS., Agents, 88 Water St., Boston.

MANUFACTURERS OF THE "SUN DIAL" GAS STOVES, FOR COOKING AND HEATING PURPOSES.

Dry and Wet GAS METERS, Station Meters (Square, Cylindrical or in Staves) Glazed Meters, King's and Sugg's Experimental Met Lamp Post Meters, Etc., Etc., Meter Provers (sizes 2, 5 and 10 feet), Pressure Guages of all kinds, Pressure Registers, Pressure and Vacuum Registers, Pressure Indicators (sizes 4 inch, 6 inch and 9 inch), King's Pressure and Vacuum Gauges, Dry and Wet Centre Seals, Dry and Wet Governors, Exhauster Governors, Photometers of all descriptions. Letheby's Sulphur and Ammonia Test Apparatus complete—also Testing and Chemical Apparatus of all kinds, and of the most perfect description, for all purposes relating to Gas.

GOODWIN'S IMPROVED LOWE'S JET PHOTOMETER.

Agents for Bray's Patent Gas Burners and Lanterns.

Special attention to repairs of Meters, and all apparatus connected with the business.
 All work guaranteed first class in every particular, and orders filled promptly.

G. B. EDWARDS, Mang'r, New York.
 E. H. B. TWINING, Mang'r, Chicago.
 Represented by S. S. STRATTON.

D. McDONALD & CO.,

GAS METER MANUFACTURERS.

(Established 1854.)

51 Lancaster St., Albany, N. Y. 34 & 36 West Monroe St., Chicago, Ill.

STATION METERS, EXPERIMENTAL METERS, METER PROVERS, PRESSURE & VACUUM REGISTERS, PRESSURE GAUGES, ETC.

Also STAR GAS STOVES, RANGES, and HEATING STOVES.

We use only the very best materials, and employ the most skilled labor, and by our long experience (32 years) and personal supervision of every detail, we feel justified in assuring the public that our goods will give perfect satisfaction. Every Meter emanating from our establishment will bear the State Inspector's BADGE, and will be fully warranted by us. Our Annual and Calendar will be sent to Gas Companies upon application.

GAS ENGINES.

GAS ENGINES.

GAS ENGINES.

THE "OTTO" GAS ENGINE.

Guaranteed to Consume 25 to 75 ANY OTHER GAS ENGINE
Per Cent. LESS GAS than DOING THE SAME WORK.

TWIN ENGINES Impulse every revolution.
THE STEADIEST RUNNING GAS ENGINE YET MADE.

ENCINES AND PUMPS COMBINED,

For Hydraulic Elevators, Town Water Supply, or Railway Service.

Special Engines for Electric Light Work.

OVER 15,000
IN USE.

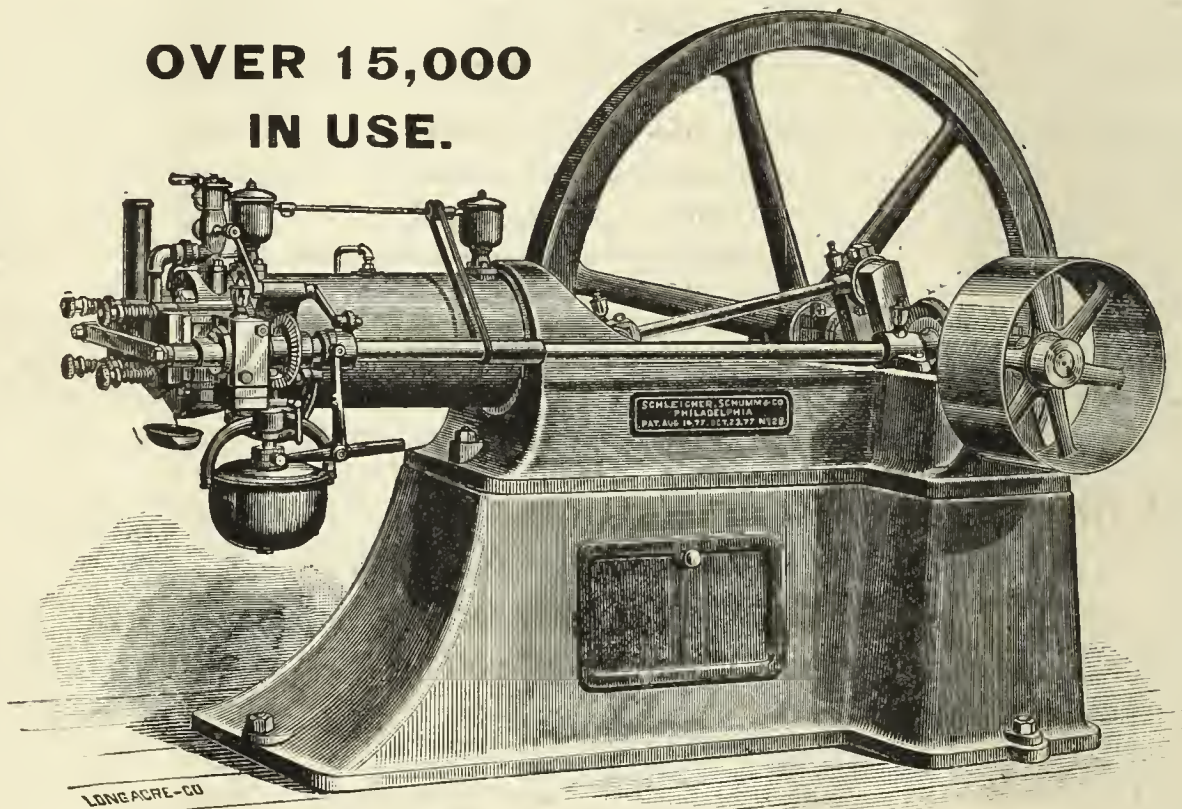

The Otto Gas Engine is now consuming, at a moderate computation, 2000 millions cubic feet of gas per year, nearly all of which is furnished during day time only.

**THE ONLY HIGHEST AWARD, ONLY GOLD MEDAL,
AT ELECTRICAL EXHIBITION, PARIS, 1881.**

MADE IN SIZES FROM 1 TO 25 HP. INDICATED.

FOR PARTICULARS, PRICES, ETC., APPLY TO

SCHLEICHER, SCHUMM & CO.,

Works:

N. E. Cor. 33d & Walnut Sts., Phila., Pa.

Branch Office:

130 Washington Street, Chicago, Ill.

THE AMERICAN

GAS LIGHT JOURNAL

REOMAN & VERNY, N. Y.

PUBLISHING OFFICE No. 42 PINE STREET

DEVOTED TO THE INTERESTS OF ILLUMINATION, VENTILATION, WATER SUPPLY AND DISTRIBUTION, & GENERAL SCIENCE.

VOLUME XLVII.—No. 3.
Whole No. 675.

NEW YORK, TUESDAY, AUGUST 2, 1887.

{ \$3 PER ANNUM,
IN ADVANCE.

A. M. CALLENDER & CO., Proprietors. C. E. SANDERSON, Manager.
JOS. R. THOMAS, C.E., Editor. T. J. CUNNINGHAM, Asst. Editor.

ENTERED AT THE POST OFFICE AT NEW YORK, N. Y.
AS SECOND CLASS MATTER.

Published on the 2d and 16th of each month, at No. 42 Pine Street, N. Y.

Terms of Subscription, Including Postage.—For the United States and Canada, \$3 per annum. European countries, \$3.50 (15 shillings—18 francs). All payments to be made in advance. Single copies, 15 cents.

Remittances should be made either by post-office order, registered letter, or bank draft on New York, payable to the order of A. M. Callender & Co.

Correspondence.—Wishing to make this JOURNAL a gazette of intelligent discussion to those of our readers who may wish to gain or give information on the subjects to which its columns are devoted, correspondence is solicited for publication from all who make the study of those subjects a pleasure or a profession.

The American News Company, Nos. 39 and 41 Chambers street, New York, are agents for this JOURNAL. Newsdealers will send orders to them.

Collections are invariably made directly from this office, for subscriptions, advertisements, etc. We have agents to solicit the same, but they are not authorized to receipt for money.

Books.—We will forward by express, at publisher's lowest rates, any book—scientific or otherwise—to any address in the United States or Canada. No books will be sent C. O. D.

CONTENTS.

An Asterisk (*) denotes an illustrated article.

EDITORIALS—

The Outcome at Springfield, Mass.....	65
The European Gas Association Meetings.....	66
Tenth Annual Meeting of the Western Gas Association—Official Report—Concluded from page 39.....	66
Question-Box—"Uses for coal tar"—"What causes the formation of small holes in the tops of some gasholders, even when the latter are but a few years old?"—Second Day, Afternoon Session—The Lungren Burner, by Mr. T. A. Cosgrove—Discussion—Enriching Natural Gas—Committee of Arrangements—Considering the Policy of Working Three Shifts of Men in the Report House Each 24 Hours—Votes of Thanks—Final Adjournment.	
Special English Correspondence.....	73
The Coke Market—Ammoniacal Liquor as a Manure—Detection of Leakage from Gas Mains—Purification of Oxide of Iron <i>in situ</i> —Societe Technique de l'Industrie du Gaz en France—The Production of Sulphate of Ammonia.	
Artesian and Gas Wells.....	74

ITEMS OF INTEREST FROM VARIOUS LOCALITIES.....

Creosoted Brick for Street Pavements—Old Wooden Water Pipes in Montreal, Can.—Holyoke (Mass.) to be Lighted by Electricity—The Transfer Completed—The Outcome at Decatur, Ills.—A Waif from Worcester, Mass.—Annual Meeting, Columbus, Ga.—A Line from Louisville, Ky.—Did not Like Gas Meters—What Does Elmira (N. Y.) Want with another Gas Company?—The Supreme Court (N. Y.) and Naphtha Gas—Mr. Garret Chosen a Director—Atlanta (Ga.) Gas Stock—Greenfield (Mass.) Gas Matters—A Line or Two from North Adams, Mass.—New Gas Company—Down Again at Nashua, N. H.—Something from Fosteria, O.—Street Lighting at Jackson, Mich.—The New Roots Exhauster—Brother Boardman Gets There—Improvements at Biddeford, Me.—Gas Matters at Fort Scott, Kas.—To be Absorbed—Home Again—Public Lighting at Oakland, Cal.—Improvements at Northampton, Mass.—Annual Meeting, Fall River, Mass.—Annual Meeting, Blughampton, N. Y.	
--	--

CORRESPONDENCE—

How Should the Flow from a Natural Gas Well be Determined?..	77
Seeking for Information.....	77
Protecting Tall Chimneys from Lightning Strokes.....	78
Coke in Russia.....	78
The Market for Gas Securities.....	78

THE OUTCOME AT SPRINGFIELD, MASS.

At an adjourned and final hearing held by the Springfield Board of Aldermen on the evening of July 18th, for the purpose of listening to closing arguments of counsel for and against the granting of an opposition gas franchise for that city, the proceedings were so interesting that the City Fathers noted not the lapse of time. In fact the town clock announced that dread midnight brooded o'er the scene ere the Chairman decided that the session was adjourned. It is no wonder that much interest attached to the proceedings, aside from the practical nature and possible effect of the official verdict subsequently to be rendered, for it is not on every night in the year that the ear of the average alderman is regaled with the tinkling, bell-like notes so easily commanded by that prince of special pleaders and most sparkling of wits—ex-Governor Robinson. We are quite aware that that Honorable gentleman is well entitled to the confidence, esteem and respect of the solid citizens of Massachusetts, and we are further aware that those who follow the profession of the law cannot always pick their company, and it is owing to such difficulty of choice, no doubt, that lawyers are often found pleading for the success of enterprises, which, to say the least, are not especially pregnant with the odor of the rose. Retainers are potent arguments, to which we might add that the smell of the rose does not equally tickle the nostrils of each inhaler—in other words, the retainer usually takes on its moral aspect irrespective of the hand that offers it. Now, we do not mean to say that we think that Mr. C. L. Long, who represented the interests of the remonstrants, is a match for the ex-Governor in the use of those witty, pleasant sentences which so often enthused the latter's political followers, but Mr. Long can quite as readily give tongue to useful facts, and is just as adept in the art of handling evidence as is the ex-Governor when the latter is at his best. We make mention of these things simply to show that the ex-Governor had a little the worst of the cause in the Springfield debate, and that therefore he can console himself for defeat by saying: "I did pretty well, under the circumstances." But we anticipate, as some ancient writers of fiction were wont to say.

Mr. Long, in opening his argument for the remonstrants, introduced a copy of the petition under which some of those confessedly interested in the company now seeking for a franchise in Springfield had managed to delude the municipal authorities of Albany (N. Y.) into giving them a chance to gobble up the old Albany Gas Light Company. The Albany case is now famous in the gas history of the country as the one in which Tony Brady managed to "drive a coach and four" clean through the provisions of a supposed-to-be iron-clad "municipal" contract.

When Counselor Long finished his recapitulation of the Albany contract he added thereto a statement which rather displeased the petitioners, and the statement was simply this: "For the benefit of the city the Springfield Gas Light Company voted yesterday that the price to be charged for gas, beginning with the quarter commencing on the 1st day of October, 1887, shall be at the rate of \$1.75 per thousand cubic feet; but consumers whose bills average \$150 a quarter shall receive their gas at \$1.65 per thousand. The city, for gas used in the public buildings and on the streets, to be charged \$1.25 per thousand." He then followed by calling attention to the fact that those most interested in the proposed Equitable Company were in reality strangers who sought

merely to accomplish financial gain, careless as to whether or not that success was secured at the cost of financial ruin to people whose ancestors actually founded and made possible the Springfield of the present. In connection with this we reproduce a line or two from that portion of Mr. Long's argument. He said: "Who are those composing the Springfield Gas Light Company? Look at some of their names—Chapin, Gunn, Brewer, Hallett. Are these men honest? Are they respected in and by the community? Years ago the founders of the Company, having faith in the future of their chosen place of residence, invested their money in a business that was deemed extra hazardous. After their early struggles came success, and this success has attracted the attention of foreigners. It is a question between the ownership of the gas works by citizens or by New York residents, who instead of being gas makers are bond makers." Mr. Long then went on to expose the fallacy of the "Baby Process," both in respect of the claims made regarding the cheapness with which gas could be manufactured by it, and as to its candle power. He asked why it was that the "Baby" had not been allowed complete swing in the works of the New York Equitable branch, if it were such a promising infant. Having noted the operations of the Equitable Company, as carried on at various points throughout the country, Mr. Long concluded his argument by saying the Equitable manipulators simply proposed to worry the old Company until its owners would consent to sell out. Mr. Long was followed by the ex-Governor, who, as before intimated, did the best that he could in view of the tools at his command. Nevertheless, wit is not argument, and flippancy does not amount to much as a converter, in view of which we will not worry our readers in reproducing remarks that, however much they entertained Springfield's Aldermen, constituted poor reasons in support of those who sought to parcel out the property of the local gas company.

The Aldermen took one week to digest the matter thoroughly, and the outcome of their ruminations was made public at the session held July 25th, when it was determined (by a vote of 7 in favor to 1 against) to grant the petitioners "leave to withdraw."

THE EUROPEAN GAS ASSOCIATION MEETINGS.

The Twenty-fourth Annual Meeting of the British Gas Institute, held this year in Glasgow, Scotland, fully redeemed the pleasant anticipations of its members, although the attendance, it appears, was not quite up to the usual mark. That defect may be accounted for, partly at least, by the necessity which required the putting forward of the time for gathering some days subsequent to those prescribed by the rules of the Society. This action was rendered necessary by the date appropriated for holding the Jubilee rejoicings, as was fully explained by our English correspondent in his letter printed in the July 2d issue of the JOURNAL. Mr. Wm. Foulis, C.E., President of the Institute, contributed a most excellent inaugural address, and subsequently directed the proceedings with rare ability and consummate tact. Indeed the reigning officer required to be a finished tactician, for he had to deal with one of those unfortunate personal matters that will occasionally crop out in the midst of the best regulated assemblies. Perhaps Mr. Bray and his friends feel satisfied over the "rumpus" which they created, and perhaps the Institute, as a whole, will have reason to be pleased with the affair when the matter is finally settled. At any rate, it seems to us that, in view of their Glasgow stand, the Brayites will speedily be given a chance to choose between fishing and cutting bait. The papers (10 in number) were up to the usual high standard, although the debates thereon seemed to lack crispness and originality. Good weather favored the members, and the purely social features of the gathering were most successfully carried out. Mr. Chas. Gandon was elected President for the ensuing year; and it was determined to hold the next annual meeting in the city of London.

The Annual Session of the Association of French Gas Managers (held this year in Nancy) was presided over by M. Alavoine, and the sessions were marked by close attention to business. In the competition for prizes offered by the Society for the best papers presented to the Congress, M. Lucien Monnier carried off first honors (500 francs), for his memoir on "The Flow of Gas through Long Pipes." The report of the Committee in charge of the affairs of the Association showed that the total membership consisted of 531 members, divided as follows: 18 honorary, 439 ordinary, and 74 associate. M. Ellissen was chosen to the Presidency for the ensuing year. The last day was devoted to the unvailing of a statue of Phillippe Lebon (it was fittingly erected in the town of Chaumont, Haute Marne, the birthplace of Lebon), whom all true Frenchmen hail as the real discoverer of illuminating gas. This statue resulted from a general subscription initiated some years ago by the Association of French Gas Managers.

[OFFICIAL REPORT.—Concluded from page 39.]

Tenth Annual Meeting of the Western Gas Association.

HELD AT ST. LOUIS, MO., MAY 11, 12 AND 13, 1887.

SECOND DAY—MORNING SESSION.

The President now directed that the

QUESTION-BOX

be opened. The first question drawn asked for information upon—
"Uses for coal tar."

Mr. Jenkins—Although I am not the author of that question I would like to have it thoroughly discussed, and am particularly interested in discovering whether or not tar can be advantageously used in the construction of sidewalks or roadways. In our Columbus (Ga.) works we, of course, have plenty of tar, refuse breeze, cinders, etc., and what I want to know is whether we can find an outlet for these materials by entering the list of roadway contractors. I understand that many of the Eastern and Western members of the fraternity have met with considerable success in the line indicated, and the question is of importance to us at Columbus, for we cannot sell our tar.

The President—Do you use lime in your purifiers?

Mr. Jenkins—No.

The President—I fear, then, that you will not be successful. For some 10 or 12 years (when we purified with lime at the Cincinnati works) we used the refuse from our boxes, in conjunction with tar and cinders, for making pavements; but since the oxide has come into fashion I find that the spent material is valueless as a pavement component. It seems to crumble and disintegrate. You want the sulphurous lime; but if you attempt to add enough sulphur to the spent oxide to make the latter as available as refuse lime you have too costly an article.

Mr. Odiorne—I have had some experience at Springfield, Ills., in making such pavements, and find that the tar resulting from Pittsburgh coal is the most satisfactory material for making walks out of. I find that tar and cinders, when mixed up in proper proportions, then carefully laid, and rolled smooth two or three days after being first put down, make very good pavements. When it wears a little rough on the top I pour some fresh coal tar on the face of the walk, brushing the tar on with a coarse broom or other device, then sprinkle it over with coke breeze or sand, which gives me a splendid road that will not crack. We probably have three or four blocks of such roadway around the gas works. In the city we have walks, some of them 400 feet in length, made in the way described, which are without a break to-day, although they have been down three or four years. I use nothing else than common rough cinders—just as they come out. We do not heat either the cinders or the tar. I did have a regular plant consisting of a mixer, grinder, and apparatus for heating the tar, but I have abolished it, and now simply use the raw tar and cinders.

Mr. Jenkins—Do you use anything besides coal tar and cinders?

Mr. Odiorne—As a rule, no. Sometimes I mix in coke breeze, and sometimes chips of stone—in fact anything that will answer the purpose.

Mr. Jenkins—Do you heat the tar?

Mr. Odiorne—No; we use it cold.

Mr. McMillin—Does the pavement become soft in the summer season?

Mr. Odiorne—Very little. It will not stick at all.

Mr. Page—What percentage of tar do you use?

Mr. Odiorne—I think we use about half a gallon of tar to a bushel of the cinders.

Mr. Page—Does the Springfield tar come from coal carbonized by regenerative furnaces?

Mr. Odiorne—No; we use the ordinary, old-fashioned furnace. Our benches are threes, of the old-fashioned kind.

Mr. Lindsley—I have had some experience in Cleveland during a period of 15 years in the manufacture and use of tar pavements, and my experience goes to show that, where raw tar had been used, in warm weather (by warm weather, I mean before it got to be very warm), for a long time the pavement would be "sticky." I have tried a mixture of pitch, as prepared for roofing purposes—about 20 or 25 per cent., as compared with the whole volume of material—and found that to be quite an advantage. In the absence of the material I boiled the tar. I do not know that I could give any precise formula with reference to my plan, and do not know what quantity of moisture I may have evaporated in the boiling process, but I boil it probably 10 or 15 minutes, or sufficiently long to feel convinced that the moisture contained had been pretty nearly forced out. Tar that has been so boiled appears to answer the purpose; but, as said, I found that when crude tar was mixed the pavement was likely to become too soft.

The President—In the suburbs of Cincinnati we sold from our works—until we adopted the iron sponge as a purifying material—all the tar, lime and breeze (worked up in the shape of a paving material) that we could handle, and received a very good price for it. In certain Cincinnati suburban localities you will find a great many tar walks that have been in use for years. They are composed of one-third fowl lime, two-thirds breeze or cinders, with just enough tar to hold them together. The action of the lime on the walk eats up and throws off the ammonia. You will find that such a pavement will be very soft at first, yet in two hours after it has been put down a man can walk over it, and after it has been down for a week a wagon can drive over it. It will last for years. In the winter time if you dig up such a pavement you will find no frost under it.

Mr. Howard—I understand that Mr. Sherman, of New Haven, Conn., has had considerable experience in the tar walk business; we would like to hear from him.

Mr. Sherman—Mr. Odiorne having stated my experience exactly, I cannot add anything of interest to what he has said. I have two or three acres of tar concrete walks around my works and in their vicinity. It makes a cheap walk, and is a great success with us. We find no occasion to use lime, in fact we never used it. Having very satisfactory walks about our works, we find it makes very little difference whether the footway is a trifle rough; but where we wish to secure a smooth surface finish we add another top dressing mixture of sand and tar, and obtain as smooth a walk as anyone engaged in the business can get by using lime.

Mr. Jenkins—Do you heat the tar?

Mr. Sherman—No, we do not heat it; we simply mix it up. We screen the cinders as they come from the furnace, using the finer portion for the top, and placing the coarser part on the bottom. We have our entire yard covered with this preparation, and find it to be a great success.

Mr. Knight—I would like to hear from Mr. Chollar, of Topeka, Kas., on this subject. Topeka, perhaps, has more tar walks than any other city in the country.

Mr. Chollar—Personally I have had very little experience with tar walks, but a resident of our city, who has followed up that business for several years, has, I suppose, probably laid 20 miles of sidewalk in Topeka. His plan affords a first rate pavement; but it is not made with crude tar. The foundation consists of the ordinary material used for macadamizing roads—perhaps broken a little smaller—which is covered with a slight coating of raw tar, and finally broken stone—the pitch is boiled and mixed with some proportion of tar, I do not know just how much—then a roller is passed over the mass which is pressed down solidly. Then the surface is covered with the screenings from the broken stone—it is a powdered limestone—when a slight sprinkling of tar is added, and the roller is once more brought into play. Very often when the walks are about ready for use they are brushed over with a swab, and then sprinkled with a pulverized stone that resembles clay. When so finished it is difficult to say whether the walks are of the tar variety, or whether they have been made from Trinidad bitumen. Aside from their looks they give excellent satisfaction as roadways.

Mr. Jenkins—Are these walks always reliable?

Mr. Chollar—Sometimes there is a little doubt about them. While not absolutely certain they have given good satisfaction. The price received by the contractor for walks of the sort described is 12½ cents per square foot.

Mr. King—A few years ago, while on a visit to Springfield, Mr. Odiorne's father made a very good suggestion to me. His theory was that tar walks gave out a great deal sooner because of the evaporation of the lighter oil, and that if we could in some way stop that evaporation we would gain by it. His idea was to cover the surface with a cement, or, when the last course of concrete was put down, to sprinkle it with cement. I thought his theory was right, and subsequently tried it with considerable success. Since that time (in the fall of 1886) I noticed (and here is where the electric light plant comes in again) that when our engineer blew out the flues of his boiler the blown-out stuff collected in a chamber in the rear of the boiler, and it occurred to me to use this refuse dust in walk making. Now, when the tar and concrete bed is ready for rolling we sprinkle the fine ashes over it, the last portion of the concrete being wetted with tar, so as to absorb a great deal of this ash. We then pass the roller over the mass, and the ash coating prevents the roller from adhering to the fresh concrete and tearing it up. Walks thus made appear to be a wonderful success, for those that we put down in the fall have stood through the winter, and are as nice looking as one could desire. In talking with Prof. Douglas about this matter he said that a great many tar walks had been put down in Ann Arbor, but the great

trouble was that they did not allow a sufficient depth to be given to the concrete mixture. The Professor says, if you put in a sufficient depth of concrete, roll thoroughly, and as the walks appear to dry out, swab with tar, allowing the same to dry, that tar walks will last for years and give good satisfaction.

Mr. Odiorne—We thoroughly roll our walks, and after grading them very nicely we sift down the coarser part to the bottom, leaving the finer material on the top. We first use a light roller, following that with one weighing about 500 pounds, and finish up with one weighing about 1,000 pounds. To keep the rollers from sticking we smear them with coal oil, and if that plan is followed you might pass them over raw tar without taking up any of the latter.

Mr. Page—I think this question is perhaps one of greater interest to the representatives of gas companies here assembled than is generally considered. The use of coal tar for the purpose of making walks has been carried on for many years in England, and to such an extent that it was impossible to buy tar from the smaller works at prices which the distiller could afford to pay. The distiller of coal tar cannot to-day afford to pay, for ordinary, good, rich tar, over 35 to 40 cents per ton of coal carbonized. Counting 12 gallons to the ton, that would be about 3 cents per gallon, or \$1.20 for a barrel of 40 gallons. It is a matter of fact that for many years a large percentage of the smaller gas companies of England have received from \$2.50 to \$3.50 per barrel. That is, as you see (instead of 35 to 40 cents), 80 cents to \$1 per ton of coal carbonized. Put that against the carbonization represented in this room to-day and you see an enormous return. The character of the coal tar, as I stated yesterday, is changing, not only among the larger companies, but among the smaller companies as well, owing to the higher heats which are carried in the present mode of carbonizing coal—in fact, the tar produced in works where regenerative furnaces are used is almost valueless for distillation. Therefore the question arises, "How shall we obtain the proper income from that important residual?" The only way that that can be obtained (and, singularly enough, a way that enhances its value) is by utilizing it for this purpose. The regenerative furnace is doing just precisely what my friend King alluded to. It is putting it into the best condition for making these walks. When you consider the condition of the soil in the Western and Southern countries in its relation to sidewalks, you will note that it is almost impossible to pass over the foot-passenger walks in many towns, simply because, wood had been chosen as the material for making them, and has been unequal to the task. They decay rapidly, and in two or three years' time they are gone. The expense of putting down wooden walks is heavy, whereas the expense for tar walks is light. It would be a great advantage to every gas manager here who is carbonizing 500, 5,000, or 10,000 tons of coal per annum to turn his entire tar product into this direction. Without any question it would bring a return, per ton of coal carbonized, in any town or city, of not less than 75 cents to \$1; and at the cost at which coal is being delivered in the Western and Southern sections of the country, you have but to put that in connection with the sale of coke, and with the gradually increasing value of the ammonia product, to see where it leads you. Therefore I would suggest, if the information already advanced is not sufficient, that further information as to proportions, to the mode, and the best appliances, be speedily gathered from those who have spoken upon the subject, in regard to the best way of doing this, in order that every gas manager may begin immediately to lay public walks at so much per square yard. Having inaugurated the system, he will find in a short time, if he does not care to continue the business with its consequent trouble, that someone will take it off his hands and continue on with it. Therefore, without any question, within two or three years every gallon of tar should be used for this purpose, and with the result that I name to you (keeping in view the fact that the value of tar as a distilling product is diminishing), which is the receipt of a return, larger I think than you can gain from the same effort bestowed upon any other given subject.

Mr. Jenkins—May I ask whether you would mix the lime and cinders together before you mix the tar with them?

The President—Yes; stir the lime, then sprinkle it over with cinders, and turn it over two or three times. You want to lay that on a bed of ashes first (if you can), and you will find that it will make a hard pavement.

Mr. Jenkins—I use a little lime. I have perhaps a bushel of fowl lime every time I change the purifiers, and that I can use very well.

The President—We could not get rid of our fowl lime or breeze; but when we put down some of the pavements spoken of a demand for the material was speedily created. To-day, were we in position to make that pavement, we could keep two or three hauling carts busy in transporting it. They have been trying to make pavements out of broken

stone and raw tar, but have not succeeded very well. Roadways of that sort speedily break up.

Mr. Page—One important point I feel that I should mention. The objection to tar walks, in Southern countries particularly, is because of the fact that the black surface attracts the sun and retains the heat, thus making it unpleasant to travel over them. In 1870, in England, I passed over a magnificent driveway—the most attractive driveway that I have ever seen in my life. It was all black and white. The white was in irregular forms. On examining it more closely I found that it was an ordinary tar pavement, made precisely as has been described by Mr. Odiorne, and broken pieces of marble, that were gathered from the marble shops as refuse, had been scattered over the surface, which destroyed the objectionable black. Residents of the Western and Southern sections have, in the vicinity of nearly every town, yellow gravel, which can be used as a finishing stone, in connection with sand. By doing so a harder surface will be secured, and the only important objection that can be urged against tar walks will be removed.

Mr. Egner—The President of a gas company, who was much interested in this pavement business, said to me that he found it an advantage to sprinkle a little salt over them. He said it caused them to become quite hard.

Mr. Lansden—Mr. Jenkins spoke of having a small amount of lime. I have made tar walks laid over a foundation of coal dust. I place the einders 5 or 7 inches deep, put over that layer a quantity of raw tar, then spread a small layer of lime—say 1 to 1½ inches thick—mix in tar with it, and rake it level on top and roll smooth. It generally takes a day or two to harden; but if made in the summer time it will harden when you run the roller over it. I never saw any cracks in a pavement so prepared. I use raw tar. I think the reason why pavements made out of boiled tar are liable to crack is because the boiling process takes out all the light oils, and there is no elasticity left. Mr. Jenkins might just as well take breeze; in fact, some superintendents do mix breeze in with the tar when they have no lime.

The next query was—

“What causes the formation of small holes in the tops of some gas-holders, even when the latter are but a few years old?”

The President—I would very much like to have some gentleman answer that question. I have a holder (it has been in use now for 12 or 13 years), on the southwest corner of which nearly every sheet is pierced right through with a small hole. On top the hole looks like a pinhole, but underneath it seems to be nicked away. It will run back three-quarters of an inch. These holes are always in one corner of the sheet.

Mr. Boardman—Is it on the under sheet?

The President—No; on the upper.

Mr. McMillin—How do you get to that southwest corner, when you go round in a circle?

The President—For the simple reason that the north side of the holder does not present or contain a bad sheet. These defects always appear on the south side of the holder.

Mr. Lansden—It has often seemed to me a singular thing that on the south side of a holder (it is several years old) under my charge there are about 500 small pinholes, while on the north side I do not find any of them.

Mr. Averill—I have had a similar experience, but the holes were in the holder top. I remedied the bother in this way: I scraped the top all over, taking all the tar off, put on a thin coating of mineral paint, followed that with a thick paint mixed in raw oil, and plastered a canvas over it. I painted and sanded the first canvas, then stretched a second canvas layer, and painted over that again. That top is now tight—and it ought to be. It is two years since I tried the scheme described.

Mr. Jenkins—That is, you have a composition roof on the top of your holder.

Mr. Averill—Yes; of mineral paint, canvas, and sand.

Mr. Lansden—Did the holes start from the inside or from the outside?

Mr. Averill—From the inside.

Mr. Lansden—The smallest part of the hole was on the outside?

Mr. Averill—Yes. They were such a bother to me that I thought I would try to stop them effectually.

Mr. Lansden—Was this repairing process conducted under pressure, or was the holder let down?

Mr. Averill—It was conducted under pressure, or while the holder was inflated.

Mr. Jenkins—Could not these holes be accounted for by the workmen dropping little globules of acid on the under side of the holder, and the rust collecting there until it had eaten through?

The President—These holes come almost on the line of the rivets. The hole runs down, and stops at the rivet line.

Mr. Lansden—I have taken sheets that were 30 years old, and found some on which the original black paint used to number the sheet was as good as the day it was put on, while other sheets were not only minus the number in black paint, but looked as if they had had the smallpox. I think it is due to the manufacture of the iron.

Mr. Chollar—The fact that two gentlemen noticed the corrosion of the iron on the south side of the holder would indicate that the heat of the sun had something to do with it.

The President—My holder is surrounded by buildings.

Mr. Chollar—But nevertheless the sun would strike with greater effect on the south side of the holder.

Mr. Boardman—It seems to me the action of the sun would have this effect—that if any chemical action took place, that change would be expedited by chemical heat. Perhaps some of the sheets, during transportation, had been exposed to contact with a spray of salt water.

A motion to take a recess until 2:30 P.M. prevailed at this point.

SECOND DAY—AFTERNOON SESSION.

Upon the termination of the recess the President introduced Mr. T. A. Cosgrove, of Evanston, Ills., who read the following paper on

THE LUNGREN BURNER.

I believe you will agree with me when I say that to-day, more than ever before, the gas interests and gas men are placed in a position identical with that of the old, reliable merchant, hitherto fairly prosperous commercially under a conservative method in conducting his affairs, but now made ostentatiously and regretfully aware that someone has located on the opposite corner, and is announcing to the public, in great flaming letters, aided by a glittering display, that he has a class of merchandise which can be adapted to the same purposes as can that of his neighbor—the pioneer. In fact, the newcomer claims that his wares will give even better results. This comparison is applicable, to-day, to the gas interests and their competitors.

I believe that it is our province to sell gas, and to sell no other agent for illumination, consequently I am not of the opinion that it is necessary for gas companies to conduct an electric plant; but having learned that some of my customers had, through the advent of the electric light, become converts to an intense, powerful light, centrally located, rather than continue with the old method of several less intense points of distribution, I looked about for some means to satisfy them without changing the nature of my business. Fortunately for me, and I believe for those interested in gas works generally, the Lungren lamp made its appearance, in its improved form, about that time. I invested in two lamps, just 13 months since, and placed them in a drug store, the proprietor of which had tried a number of various systems, but was still, although he was at once pleased with the volume of light, dissatisfied. He was skeptical at the beginning as to the merit of the lamp, claiming that he had never yet seen the gas appliance that would not consume more than the manufacturer claimed for it. We then took the state of his meter, and again at the end of 30 days—in the meantime he kept account of the number of hours of burning. The result proved even more satisfactory than I had anticipated, as the quantity of gas consumed for the number of hours of burning tallied exactly with the claims of the Company. It needed no persuasion to sell him the lamps at the price charged by the Company, with an additional reasonable charge for work in hanging. Recently this consumer happened to be at the office to pay his bill for the preceding month, and on referring to the book I noticed that the lamps had been sold him one year before. I asked him if he would like to dispose of them, and he answered that if he could not buy another he would not sell them at five times the price he had paid. Since selling that lamp I have introduced quite a number, and in each instance have sold the lamps outright to the consumers, volunteering to give any little attention that they might need, without making any charge for it. The result, in every instance, was highly satisfactory, both to the consumer and to our Company. Although we have not attempted to rent any lamps, I understand that, in many cities and towns, the rental system has been adopted with marked success. In a conversation with some of the members of the Company, at their office, I was told of Minneapolis, Minn., for instance, where the Gas Company rents the lamps under the name of the “Siemens-Lungren Renting Company,” of Minneapolis.

Their rental price, per lamp per month, is \$1.00, and they send a man twice a week to each lamp to clean the globes and keep the lamp in perfect condition. This, at the rental price, they can readily afford to do and still leave a very handsome margin of profit; and I have also seen

a copy of a letter from Mr. Raud, Vice-President of the Minneapolis Gas Company, in which he wrote that they will rent at least 500 the first year; that the merchants are pleased with the lamp, its illuminating power and the rental price, and that they have already placed 140 on rental within a space of 60 days. In the city of St. Louis, Mo., a rental company has been formed, composed of gentlemen connected with the gas interests here, and several prominent merchants. The price here is, I believe, similar to that in Minneapolis. The company here has fairly started, but their first victory won over their neighbor on the opposite corner is a notable one. The "Famous Shoe and Clothing Company," a prominent retail concern in St. Louis, occupying a large block near the market space, had an electric plant of their own, the plant having a capacity equal to the supply of 65 arc lights. These have been displaced by 120 Lungren lamps, on the rental plan, and the electric plant is for sale.

I have been informed, by members of the Siemens Lungren Company, that they will have a lamp ready, for outside illumination, this fall, as well as various additional sizes for indoor work.

In view of this effective weapon placed at our disposal, and with the surety of a very fair return on the investment, I believe it to be to the interest of everyone connected with the gas business to urge the introduction of these lamps, and I urge it most heartily and sincerely.

Discussion.

Mr. Cosgrove—In addition to the facts contained in the paper I can say that now I have four consumers who use the Lungren lamp. Prior to receiving the Lungren lamps I could not by any means induce any one of the four to burn gas—they had used kerosene oil for 14 years—so you see I am getting consumers for gas by the aid of the Lungren lamp that I never could get by any other means. I put the lamps up for them, allowed them to have the same for a week, and agreed not to charge them anything either for the lamp or gas if they were not pleased. In each case the lamp remained.

Mr. Gimper—In connection with the Lungren let me say that I have experimented with them. I was very cautious with them at first, for we invested in various other lamps before which proved to be unsatisfactory. I ordered two Lungren lamps to begin with, and their value was such that I ordered 15 more of them. I kept on purchasing them, and now we have 60 in use in our city. A large building under control of the city authorities is now partly lighted by the Lungren lamp. We sent two specimens of the lamp, together with a meter, for trial by the authorities—the latter inclined to the idea that the lamps would consume more gas than the rated quantity. The tests, which were carefully made, showed that the lamps kept within the 12 and 16 cubic foot per hour consumption quantities at which they were respectively rated. We have been able to replace quite a number of incandescent arc lights by means of the Lungren lamps. We rent them at 75 cents each per month; but in order to displace an electric light or lights, if the consumer refuses to pay rent, we let them have the lamp without charge. They are undoubtedly an excellent weapon with which to fight the electric light—at least we so find it; and I have no doubt that all who try them thoroughly, and introduce them properly, will be successful in routing the electric light.

Mr. Harbison—Before this discussion is closed let me say it seems to me, unless the members of this Association generally are already pretty well posted with regard to the merits of the Lungren lamp, that it is a subject well worthy their attention. I do not know of any other means of illumination that can compete with that produced from gas consumed in a Lungren burner, and I also think that the gas consumer, once its usefulness is shown to him, will be satisfied as to its economy. However, I do not agree with Mr. Gimper's way of doing business. He charges one consumer 75 cents per month for the use of the lamp, but makes no charge to another party who refuses to use it if obliged to pay a rental charge. I think that in one case he does an injustice to the consumer, while in the other case he does an injustice to the gas company. It would be better to equalize it and charge only that which would allow a reasonable interest on the investment made by the gas company in the purchase of the lamp, also making a proper allowance for wear and tear and use of the lamp. A rental charge of 75 cents per month would pay for a lamp in 2½ years, and I think that that is too large a dividend for a gas company to get out of a consumer. If the rental charge were put at 25 cents the company would still get a fair return for the money invested in the lamp, while a great many more consumers could afford to use it. Our Hartford doctrine is to treat each consumer alike, no matter what quantity of gas is used per month, and without reference to condition. The poor man who receives \$1.50 per day, on which he must support a family of five or six children, ought to get his gas at as low a

figure as that paid by the bondholder with his hundred-thousand-a-year income. That is the way we do in our city. Cause as many as you can to buy the lamp, and put it up for them at cost, and then you will reap a benefit from the sale of the gas so consumed; but if you rent the lamp, charge the same rent to everyone—put them all on an equality. Give them all the same quality of gas, and measure your gas to one as you do to another. If you do this you will find that it will not be necessary to put a great deal of your money in electric light plants, or in water gas plants, or in any of the other new-fangled notions constantly paraded before us. Adhere strictly to a legitimate coal gas business, and you will make money enough, at a fair price, on an honestly-invested capital. The Lungren lamp is worthy the careful attention of every gas man, and the greater the number of those lamps that you can introduce in your city the better it will be for the consumer and for yourselves. There is not so much variation in the gas bills of those who use the Lungren lamp as compared with cases where ordinary burners are employed, for, as a rule, in the latter instance a consumer will have from three to six jets in a room, hence the variation; but as one Lungren lamp will give as much light as that emitted from any 6-light chandelier, not only will there be greater uniformity in the bills but less gas is consumed. Some may say that it is a remarkable thing for a gas man to recommend the Lungren lamp (which will burn only 16 feet per hour, whereas a 6-light chandelier will burn 24 feet per hour), yet the success of a gas company does not depend altogether upon the amount of the gas bills of any one man, but rather on the general satisfaction of the whole number of consumers; and if you can so manage your business and so supply your consumers that every man who burns your gas is speaking a good word for you, kerosene lamps will disappear, and those who have not hitherto burned gas will begin to use it. Furnish it at a low price, and strive to increase your consumption in every way, for the greater consumption you have from your plant the cheaper you can afford to furnish the gas, and make just as much money for your stockholders.

Mr. Gimper—I agree with what Mr. Harbison says with regard to that; but we do not own an electric light plant, as he does.

Mr. Harbison—I beg your pardon; we do not own any electric light plant, and have not a dollar in that business.

Mr. Gimper—Then I have been misinformed. Perhaps we at Leavenworth have to deal with a different class of people than those who reside in Hartford.

Mr. Harbison—Yours may not be educated up to our standard yet; but keep on.

A vote of thanks was passed to Mr. Cosgrove.

The President having explained that the Question-Box had been emptied, the discussion turned to the subject of

ENRICHING NATURAL GAS.

Mr. McMillin—I think we should take up the question of the cost of enriching natural gas. The President made a very bold assertion here, and I hope someone may be able to show that he is mistaken about it. I have no testimony to offer myself. Messrs. Denniston and Critchlow, of Pittsburgh, Pa., are here, and as they have had considerable experience in this direction, perhaps they may be induced to enlighten us in regard to a very interesting subject.

The President—We shall be glad to hear from the gentlemen.

Mr. Denniston—I did not come here to speak, but rather to listen, for I knew that I thus could learn by so doing. I thank you, however, for the opportunity to say a word in regard to the topic raised by Mr. McMillin. I recognize the fact that the President, in his address, as well as from papers which have been read by other members here, tell us not only about what they know, but also about some things which they believe, but which they are not positive of. I have no doubt that the President believed what he said about natural gas, and I would have agreed with him three years ago, for at that time I held the same opinion that he does now. When I read, at the Cincinnati, Ohio, meeting of the American Association, my first paper* on natural gas, I asserted that various experiments, entailing considerable expenditure, had been made, but that as yet natural gas had not proved a success; that for the present I did not fear it as an illuminant; and that while it made a good fuel gas I did not believe it was going to come into competition with coal gas. Now you will bear me out, and the report in the AMERICAN GAS LIGHT JOURNAL will also bear me out, that I then said that if natural gas ever did assume the role of a competitor it was the province of coal gas men to take hold of it and make light of it—in both senses of the word; to use it, and make a good light of it. If it could be made available at all, I then claimed that it was the province of the coal gas men to utilize it,

* See JOURNAL, Dec. 2, '85, p. 232.

in lieu of the natural gas men, or those who were introducing it for fuel, and to occupy the field for illumination. That has been my experience. From that time I have been experimenting. As far as I was concerned, after spending some considerable money in the experiments, I failed; but, as I then suggested, some others have succeeded, and when they did succeed I immediately wanted to close in and get a part of the pie. I went to the parties who were successful in manipulating it, and when I found that it was really a success I put it into my own works. My coal gas benches are standing idle to-day. Those who last year attended the Philadelphia meeting of the American Association will remember that the cupolas in my works were not completed. Shortly after that meeting some of the delegates visited my works, and, while the plant was not in real working order, it was sufficiently advanced to show that a high candle power gas could be made from natural gas in the way proposed. I think it was demonstrated to most of them that gas could be so made at a lower cost than if coal gas were made. Since that time that fact has been amply proven; but, as the proof of the pudding is in the eating thereof, so the proof of success of this is that those who have tried it will bear me out in asserting that, like me, they have laid aside their coal gas benches. Their, retorts, stand-pipes, etc., stand cold, and they are making more gas with the small cupola furnace than they could with four benches of threes under the coal gas system. I do not want to occupy too much of your time over this matter, because I am free to say to you that I am personally interested in it. However, I will state that there are four things in its favor. First comes the cheapness of the plant—I have a small works that cost \$5,000, in which I make more gas, and at one-half the cost, than I can in a coal gas works that cost me \$25,000. The first proposition, then, is the cheapness of the plant. The second is the cheapness with which you can make the gas, because of the cheapness of the material—natural gas and oil (using any merchantable crude oil) and the coke or hard coal. You can make the gas without steam. I do not mean to say that you cannot make water gas, too, for you can; but you can make it with or without steam, as has been proven. Then, in the third place, we have the consideration of the high candle power that you can gain with this same material. I made, up to that time, 16-candle gas, which is the legal standard in our city. To-day, because of cheap natural gas, with an ordinary illuminating power of 8 candles, and the competition of incandescent and arc lights, which run anywhere from 8 candle power up, I have to sell an 18 to 20 candle power gas. Now we make out of this cheap plant, and this cheaply made gas, a better illuminant than was ever used in the East End of Pittsburgh before. One other thing in connection with this plant I should mention, and that is the fact that it requires no expenditure to keep it in repair. Each year, with coal gas works, you have to repair or rebuild retorts, stand-pipes, mouthpieces, benches, etc., while inside of this cupola you have simply firebrick. That is all there is about it. It does not cost \$25 to reline it, and it requires relining only once in about two years. That is a fact, as Mr. Egner said the other day—although you may not believe it—for it has been done. When the natural gas has been treated you have a high candle power, non-condensable gas. At Beaver Falls, Pa., where Mr. Critchlow has been running the process for two years, a pipe is exposed (between Beaver Falls and New Brighton) on a bridge which spans the Beaver river, but the drip at the end of that bridge has never yet been pumped. In fact, there is nothing in it to pump. If that were a condensable gas it would show itself right there. So, without occupying any more of your time, I want to say to those who are in the natural gas district—make friends of the natural gas men; for if you do not somebody will get up an opposition company. I am in the same boat with every man who has competition of that kind to deal with. I had it in my own place. I experimented, trying to make use of it. Then I went to them and said, "I am going to be a good customer of yours; sell to me cheaply, and I will use your natural gas for an illuminant. You cannot run it through the same line for both heat and light. If you get pressure enough on for heat, then it is too great for light; if you get it so low that you can use it for an illuminant, then it is too low for heating your furnaces, or even for use in your dwelling houses." They listened to me, and we agreed. I use natural gas in my house and in my office; and they in turn use my gas in their offices. They use mine as an illuminant, and I use theirs for fuel. I take their gas and make an illuminant of it; they furnish me my fuel. I would not be bothered with coal where I could get natural gas for fuel; and they on the other hand would not be bothered with their own gas for an illuminant, although they get it for nothing. Therefore, it is for the interest of parties who are coming in competition with natural gas throughout the Western country, and it is the interest of the natural gas men in your vicinity, that they should sell it to you, and that then you should make such a light of it that they cannot afford to use their own gas for

light. You can do it, and you can do it so cheaply that probably you would not believe me were I to tell you how cheaply it can be done. To anyone who wants to make the experiment, or who does not want to take my word for it, let him come to our works, or to any of the works in Western Pennsylvania, in Eastern Ohio, or in Southwestern New York, and see how it is done. If you do not go away satisfied, you are not the coal gas men that I take you to be.

Mr. Watts—How many pounds of anthracite coal, and how many gallons of oil, do you use per thousand feet of gas sold?

Mr. Denniston—I will leave my friend Critchlow, who is the patentee, to give you these items. I can tell you what I did, and you can count it on your fingers, if you wish to. I put in about 2,000 feet of natural gas, which cost me, say, 5 cents per thousand. You can call it 10 cents, or twice as much. Then I used 10 or 12 gallons of crude oil, which cost me 2 cents per gallon. It does not cost that much, in fact; but I am putting it at the highest figure. Neither does it cost that much for natural gas; but I am giving it to you so that you can have some data to go upon. Then I will use, say, 100 pounds of coke or hard coal (we use coke), which will cost about 20 cents.

A Member—Can you use coke or coal?

Mr. Denniston—Yes; but we don't use our own coke. It is not advisable to do so for the reason that you form so much clinker. You must bring it to incandescent heat—not only the coke or coal, but the brick-work above as well—and the natural gas, entering at the bottom and passing up through, comes in contact with the oil, which is fed in as a spray, or comes in with steam carried in through a pipe above. There you have the natural gas, the oil and the coke. That is all there is of expense, except the labor and purification. The first cost of the plant is insignificant, and the cost of your gas is comparatively insignificant. I have not given you the output. I put 6,000 feet of merchantable gas into the holder, averaging about 20-candle power.

A Member—With how much labor?

Mr. Denniston—One man will run two cupolas. It is very difficult, as you know about coal gas, to gauge what you can make gas for by what it costs me. Your location and surroundings, and so many things that enter into the first cost, so change the conditions that you cannot take my statement as a certain indication of what it might cost you. For instance, if you are only running from ten to fifty thousand feet per day it is fair to assume that it will cost you more, proportionately, than this cost me when I am making from 100,000 to 500,000 cubic feet per day. The more you make the cheaper it can be made in proportion. The output is, in part at least, the basis for your cost. If Mr. Fullagar can make gas as cheaply in Cincinnati as I think he can, and as cheap as any coal gas man, then I would like him to come and see what, in a small place, and with nothing like the output that he has, and with none of the modern appliances, in fact with only a small plant that was put in by this Company, what he can do it for. I think he will turn his tune and sing a different song next year. I venture that assertion and I can prove it.

Mr. Scofield—But Mr. Fullagar has no natural gas.

Mr. Denniston—He will have it.

Mr. Howard—What faith have you in the continuous supply of natural gas?

Mr. Denniston—I have faith in it for the reason that for 15 years, to my certain knowledge, the flow from one well has supplied the iron works at Sharpsburgh, across the river from Pittsburgh, and the diminution in the flow from that well does not amount to anything. On the other hand, I should not like to answer for the permanency of the flow where you get it at very shallow depths. Within the city limits there have been wells put down, and a considerable supply of natural gas found, but they have fallen away. They have also fallen away throughout the oil country in Western Pennsylvania, as they have throughout Ohio and Western Virginia. Where some years ago there was sufficient gas to supply engines, none is now found at all, so they have had to come back to the use of coal. Of course, the gas flow is not all alike, anything more than the making of your gas is. If the output is large the cost will be just so much less comparatively. Now suppose you only put out 50,000 feet. You must have a man attend to it. True, he may do it in a few hours; but that same man would make 300,000 feet with the simple additional cost of \$1,000 for a cupola. You can put out 300,000 feet at nearly the same cost for labor that you can put out 50,000 feet.

Mr. Boardman—You purify that gas, do you not?

Mr. Denniston—Certainly.

Mr. Boardman—How often do you change your purifiers?

Mr. Denniston—Not very often. There is nothing like the trouble that there is with coal gas. I only use two purifiers. I put in a layer of

sawdust first, and follow that with only a layer of lime. The gas is not very impure; but yet it needs purification. If you use a different enriching material—for instance, if you use naphtha, that will not cause the amount of impurity that crude oil does. I am using the dirtiest, stinkiest oil in the market. You cannot touch it without the smell remaining with you for days; and yet with that I am putting out this 20-candle gas to the extent that I have stated.

Mr. Harbison—What is the price of gas in Pittsburgh?

Mr. Denniston—Two years ago I was selling gas at \$2.50. I sold gas first at \$3, then at \$2.65, then at \$2.50, with 20 per cent. off; then at \$2, with 20 per cent. off, or \$1.60. Since I put in this machine I am selling gas at \$1.50, with 10 per cent. off, or \$1.35. And I may say to you that I have been offered an electric light plant, which was put up in my place just before I put in this machine, at 20 per cent. below what it cost a year ago. Next December the natural gas plant will have been in operation one year, but I can to-day buy that electric light plant, which took from \$8,000 to \$10,000 of my receipts from me inside of a year, at less than it cost them a year ago. And that is not a singular instance. There are others. The question was asked yesterday (but I did not like to intrude myself upon you, and hope you will pardon me for mentioning it now) as to how best to beat the electric light. I answer: First, get natural gas; then put up one of the Critchlow-McKay machines, and you are in a position to beat the electric light all to pieces.

Mr. Harbison—When you were selling coal gas what was your lowest price per thousand?

Mr. Denniston—\$1.60.

Mr. Harbison—So that your consumers have gained 25 cents per 1,000 feet by your introduction of natural gas?

Mr. Denniston—By the introduction of this process; and I give them better light than they ever got before.

Mr. Harbison—I wanted to bring out how the consumers were receiving a benefit from it.

Mr. Denniston—I will tell you something more than that. The receipts have kept up right along from the time I reduced from \$2.65—two and a half years ago. So that to-day, at \$1.35, my receipts per month are as good as they were then.

Mr. Watts—Has the town increased in population?

Mr. Denniston—Yes, we are increasing. Like some of our energetic Western towns we have increased in population by importing some from Connecticut, and some from across the "drink." But that increase would not make that difference if we had not what Mr. Harbison calls the good will of the consumers, for if they were not satisfied with this gas they would not use so much of it. They would use the natural gas, which they can get for one-twentieth of what they pay me for this gas. But they won't use that. Mr. Westinghouse, the President of the Philadelphia Natural Gas Company, pays me \$100 a quarter for light, and the other officers of that Company are using my light in the East End. I believe the light that I give is as good as the Edison, or any other incandescent light. I do say that you cannot get the same candle power from the present incandescent lights (and I am interested in an incandescent light plant) that you can from gas from this machine, or from any good coal gas.

Mr. Watts—I should think that your consumers would be dissatisfied because of the fact that you are making such a profit out of them.

Mr. Denniston—Mine is a suburban district. I am not in the center of the city. I have nearly 40 miles of pipe, and upon that 40 miles (until last year) I had only 1,000 consumers. I think I would be safe in saying that there is not another gas company in the United States, or in Canada, that had so much pipe, so large a plant, and so small a consumption. Of course, the class of consumption is good, when I get to it. They are people who do business in the city, and who live out at the East End. They are a good class of people, who live in a good class of houses, and are good cash customers. But the very best business street—in the central business portion of the East End, between the 19th, 20th and 21st wards—is lighted by incandescent lamps. On the other main streets, where my best consumption is, the houses average from 500 to 700 feet apart. In a building like this hotel, for instance, where there may be half a dozen meters, more gas is probably consumed than I could sell in a mile on one of those streets. The business portion, as I have stated, has been taken during the last year by the electric light.

Mr. Harbison—What is the estimated population of the territory in which your pipes are laid?

Mr. Denniston—I cannot give you that. I know about what the population of the city is.

Mr. Harbison—Have you 25,000 or 30,000 people.

Mr. Denniston—There is that number in my territory. My district extends from the Monongahela, on the south, to the Allegheny, on the

north; and from the old city line, as we know it, of Pittsburgh, on the east, out to Wilkesburgh, on the west. That area is five times larger than that of the city of Pittsburgh proper. I have got mains on only a few of the leading streets. I expect to have a mileage there some of these days that will come up to something like that of St. Louis or Chicago.

Mr. Page—The cost of the raw material, as given by you, would be as follows: 2,000 feet of natural gas, at five cents—ten cents; 12 gallons of crude oil, at two cents—24 cents; 100 pounds of anthracite coal, at 20 cents. How much gas do you get from that?

Mr. Denniston—I put into my holder, with my single cupola, anywhere from 5,000 to 6,000 cubic feet. One cupola at Sewickly, put up since mine was, and a little larger than mine, is being operated by a gentleman named Forbes, who says that he beats the record, for he puts in 10,000 cubic feet. As I have said, the cost of the gas will be in proportion to the output. In other words, if you can run two cupolas the cost of the gas will be less than if you run but one. If you make 100,000 feet it will cost proportionately less than if you make 20,000 feet.

Mr. Sherman—Is there any water gas in that?

Mr. Denniston—Not a particle, unless you want to put it in.

Mr. Sherman—In those figures no allowance was made for steam?

Mr. Denniston—No. We are operating the Springer cupola, because it answers our purpose better than any other, and because of its insignificant cost as compared with what others want to charge us. They made a fair arrangement with us for the use of their cupola, and we are using the Springer cupola in which to convert the natural gas. By means of an additional expenditure of \$500 these cupolas can be made ready to manufacture water gas in case natural gas fails. We made that arrangement with them. They guarantee that they will make water gas if we cannot get natural gas.

Mr. Egner—There is 12 gallons of oil, 2,000 feet of natural gas, and 100 pounds of coke. Now, as there is 4,000 feet of gas to be accounted for, are we to understand that the increase comes from the oil and the coke?

Mr. Denniston—Yes; but the increase in the bulk of the natural gas is considerable in itself.

Mr. Egner—I was in doubt about your statement, and wanted to understand it.

Mr. Denniston—Seeing is believing. I do not wonder at your doubting; I doubted myself at first. I want you to come and see it. It is worth your while to come and see it. If you conclude to try it and it does not do what is claimed for it, it will be taken away again without a cent being charged.

Mr. Harbison—At what temperature is the gas measured?

Mr. Denniston—I cannot tell you precisely. I presume at about the usual temperature of coal gas after passing through the purifier. I have a station meter, and I measure the gas as it goes through. We have tested it, both theoretically and by putting the meters on. We cannot get it exact, for the reason that, at the high pressure of the natural gas itself, it is difficult to use the meter; so we have to reduce that in order to make a correct measurement. We say to the people from whom we purchase the natural gas that it does not make any difference whether they take our estimate or put their meter on and measure it for themselves. In point of fact, I am paying them for 27½ per cent. of the output, and I do not believe that I use over 33 per cent. at the very most. Sometimes, possibly, it is over that. If you reduce the candle power you can take up more natural gas. If you want to get high candle power you can use that much less, and put in more oil, or steam.

Mr. Page—Is the gas more or less smoky than coal gas?

Mr. Denniston—I cannot notice much difference. It is probably not as smoky as rich coal gas. In any rich coal gas some unconsumed carbon is carried up to the ceilings of the rooms. I have noticed, when I attempted to make rich coal gas, that the ceilings got very dirty. It is not any more so with natural gas than with rich coal gas. It is being used in the best houses in the East End, and in Sewickly; and we have had no complaint wherever it has been put in.

Mr. Page—What is your estimate of the condensation?

Mr. Denniston—Nothing at all. I take no account of it. It does not condense in anything like the degree that coal gas does. Of course, if you want to hurry the operation you can make a condensable gas. You can run it through so rapidly that you will have only a vapor. If I could make coal gas as cheaply as this I would not be selling these machines right around Pittsburgh, where they can dump the coal right out of the coal bank into their works. Coal gas can be made there as cheaply as it can anywhere else in America. Of course, in estimating the cost of coal gas you consider your residuals and take them off your first cost. You expect to sell so much tar and coke, and, in large works, you expect to get something for your ammoniacal liquor. That all counts, and

of course reduces the first cost of your coal gas; but when these have been disposed of to the best possible advantage, and when such items as difference in cost of and repairs to plant are concerned, and a balance is struck, you will find that the Critchlow-McKay process gas is by far the cheapest. This process is now being used in Allegheny, Sewickley, in the West End, and in Pittsburgh proper. At first I did not like the name of the thing. I was fearful that the consumers would "kick;" that they might say, "These fellows are getting natural gas at 10 cents and selling it to us at \$1.50." I did not want any ill feeling of that kind, and so they did not know what they were getting until the general sentiment became decidedly pronounced in favor of the increased candle power of my gas.

Mr. Critchlow—I would like to answer Mr. Egner's question. He thinks that there is an apparent shortage in Mr. Denniston's account. That comes about in this way: The composition of natural gas is 70 to 90 per cent. marsh gas. The decomposition of that, as we find in practice, gives us 1,000 feet of hydrogen gas from putting 350 feet of natural gas into the eupola. That is a practical test. Theory will give you still more. We have demonstrated that fact—making all due allowance for temperature—that putting 350 feet of natural gas through incandescent coke puts 1,000 feet of gas in the holder, with the use of 2 gallons of oil per thousand. Since the question of cost has been raised, I do not know that our Company has any objection to going on record with regard to it. At West Pittsburgh we are putting gas in the holder, exclusive of superintendence, at a cost of 13 cents per thousand. We have 20 cupolas in Western Pennsylvania and in Ohio, where the price ranges from 11 to 18 cents per thousand. We use 2 gallons of crude oil per thousand (which costs us 2 cents per gallon at the works), or 4 cents for oil. We use 20 pounds of coke, which costs us about 5 cents a bushel at Pittsburgh. The cost of the natural gas is 5 or 6 cents per 1,000. We are satisfied, from experiments made, that in putting 1,000 cubic feet of gas into the holder we are only using one-third that amount of crude material; consequently we pay the natural gas people 2 cents per 1,000. Now, adding a fair charge for labor, we find that the fixed product costs us, at West Pittsburgh, about 13 cents, exclusive of superintendence. To be perfectly safe, we will put the cost at from 13 to 18 cents. I think I am entirely safe in saying that three-fourths of the illuminating gas made in Pittsburgh to-day is either from natural gas or decomposed water gas. One-third of it is water gas, one-third natural gas, and the balance is coal gas. If there is any apparent discrepancy in the statement as to what can be done, I shall be glad to be corrected by anybody who thinks he sees anything which is not strictly accounted for.

Mr. Scofield—What is the object in making water gas when natural gas is so much the cheaper?

Mr. Critchlow—Both at Allegheny and at Pittsburgh Mr. Young and Mr. McElroy had a contract with the Granger folks for the erection of these cupolas (theirs are the works in which the majority of this gas was made) prior to the successful operation of our system. In short, these gentlemen were making water gas, and in fact Messrs. McElroy and Young have only been converted to our system within the last 3 months. There are gentlemen in this room who will testify that, in answering inquiries made to them about our system, Messrs. McElroy and Young have spoken well of it.

Mr. Scofield—I have had some correspondence with Mr. McElroy. I visited his works last year, at which time Mr. Young was using 14 per cent. of natural gas. Hearing about the Critchlow process, I corresponded with Mr. Young, and also with Mr. McElroy, in order to learn from them the facts of the case, and they stated to me substantially what Mr. Critchlow says. They corroborated all of the statements that Mr. Critchlow has made, and I think went a little beyond, if anything. Being somewhat interested in the gas business, since I am located in the natural gas district in Kansas, I have been looking into this matter so that I might be able to hedge myself against all influences and combinations that might affect my business.

Mr. McMillin—It occurs to me that a little water gas might not be a bad thing in connection with this system. Having always been a water gas man, I feel like adding a word when I can. In passing natural gas through the incandescent coke, and decomposing it, they throw down some carbon. If they did not use that in heating up their eupolas of course they could use it very advantageously in decomposing steam and making water gas. It is already there at the proper temperature, and by passing steam through it they can make water gas cheaper than we could make water gas if we were making it in the usual way. And, again, the natural gas, before it is put through this process at any rate, and possibly after, is a little deficient in the properties that give it intensity. While it is the greatest heating gas known at the present time, so far as quantity is concerned, yet in intensity it is very low. I

would expect some advantage in using a little water gas in connection with it.

The President—I do not see what would be the use of going to the trouble of decomposing natural gas, and attempting to use it in Critchlow's process, or in any other, when this Welsbach burner is about to do away with all processes. All you have to do with it is to use the natural gas directly.

Mr. Denniston—Some statements have been made here with regard to the electric light. You would not need anything but gas when that new burner comes out. You remember what a tumble there was in gas stock some years ago. I did not believe in this thing for some time. I do not say it is not possible for you to have such a burner. I was guarded in my statement about natural gas as an illuminant. I have examined all the burners that came out. I have tried them all. There are some burners that will make a better light than the ordinary burner. You have to have a burner for coal gas, and a burner for water gas, and there is going to be a burner for this gas; but, in the meantime, do not fool away your time, but utilize what you have got.

The President—This burner is so great a success that it is said that some Pittsburgh and Philadelphia men have put \$10,000,000 into it.

Mr. Denniston—I have heard of that. You can see what you can do with one of these machines as against the electric light. I do not mean to say that you may not get a burner that will use natural gas and burn it well, but I do know that natural gas can be made a good and cheap illuminant—cheaper than you are making to-day out of coal gas—and that with it you can defy competition.

Mr. Egner—I will ask Mr. Critchlow to explain the method by which natural gas is converted into illuminating gas. I for one do not understand how they convert it. I guess at it, but I do not know it. For our general information perhaps he will tell us. It is patented, and so there can be no harm in describing it.

Mr. Critchlow—I have no objection to stating it. You pass the natural gas in as you would steam. We have the eupola so arranged that, by reversing the valves, we pass natural gas through the same opening that we did steam when making the water gas. It passes in at the base and up through the fire; the oil or hydrocarbon is injected above the fire, and it all passes through the superheater together, just as in water gas manufacture. The decomposition is effected in the passage through the fire. Our claims are strictly process claims, and are applicable to water gas apparatus.

Mr. McMillin—I think when Mr. Egner goes back to his office, and gets to figuring on the chemical composition of the gas as it enters the eupola, and what it would probably be when it emerges, after being subjected to that sort of heat, he will see that the claim they make—of getting three to one—is not an unreasonable one; and even if not enriched at all I would expect it to be a better light than it was before, by reason of the very large excess of free hydrogen which would be in it. In many localities the natural gas has no free hydrogen, and in none of them has it enough to give it the proper temperature. Those of you who have seen natural gas burning will remember that they had to burn a very large flame in order to get any light at all, and that there is no distinct demarcation between the blue part of the flame and the bright part—the blue runs up into the yellow, and the yellow runs down into the blue. The result is that the carbon burns up instead of becoming incandescent. It is all burning there together, because it is a compound. It is marsh gas, CH_4 . When he passes that through coke he breaks it up. He forms some compounds which are higher than marsh gas, and which will add illumination, even when burned under the same circumstances. In addition to that, he gets a larger per cent. of hydrogen, and that hydrogen will burn down towards the tip of the flame and heat the carbon up to incandescence. Natural gas so treated would give a better light, even were no oil used, than it would in its original state.

A Member—Does Mr. Critchlow measure the natural gas that is used?

Mr. Critchlow—We have measured it at times in order to demonstrate to the natural gas company that we were using such a proportion as we claimed to be using; but in ordinary practice we do not measure it. We prefer to have it go into the eupola at a pressure of two pounds, and having demonstrated that by paying them a certain percentage on our output we were making a just and equitable arrangement with the company, we then put it in directly from their high pressure mains. We have one works, however, at Titusville, Pa., where they measure it through a six-inch meter. It is much cheaper, however, to run it through under high pressure, as we can use a two-inch pipe; whereas, under a low pressure, and measuring it, we would have to use a six-inch pipe and large meter.

[This ended the discussion.]

COMMITTEE OF ARRANGEMENTS.

The President appointed, as a Committee of Arrangements for the next annual meeting, Messrs. Henry Pratt, E. H. B. Twining and Geo. C. Hicks.

A member asked the following question :

"Would it be policy to adopt three shifts of men in a retort house, each gang to work eight hours per day as a day's work?"

Mr. Egner—I believe it would be policy, for I think that 8 hours per day will eventually prevail, and I so believe it would seem to be good policy to take the bull by the horns. But we ought to introduce the system in the fall of the year, or when labor is looking for a market. During that season many men are looking for work, and there would be no difficulty in securing their services on equitable terms. Many men who can do eight hours' work in a retort house would break down were they asked to labor for 12 hours. I believe it would be a good thing for us to introduce it, because I am satisfied that eventually we will have to come to it. Retort house work is beastly work, and we will have to come to 8 hours unless we can get charging machines which will take the place of manual labor. Here in St. Louis ordinary laboring men get \$1.50 per day, while in the retort house we pay \$2.75. I believe that we could get three men to do the work at a sum equivalent to that which we now pay two.

The President—In view of the agitation of the labor question throughout the country this is an important matter. It may be that we shall have to fall back on Egner's plan of cheaper labor and shorter hours. We find now that it takes three men really to do the work of two. That is what it amounts to with us; but with our present high rate of wages we cannot afford to use three shifts of men.

VOTES OF THANKS.

On motion of Mr. Howard, the thanks of the Association were tendered to Mr. John Fullagar, the retiring President, for the able and impartial manner in which he discharged the duties of his office.

On motion of Mr. Thomas, a vote of thanks was passed to Secretary Littleton.

The Association then adjourned, to meet in Chicago, on the second Wednesday of May, 1888.

SPECIAL ENGLISH CORRESPONDENCE.

COMMUNICATED BY NORTON H. HUMPHRYS.

SALISBURY, July 9, 1887.

The Coke Market.—Ammoniacal Liquor as a Manure.—Detection of Leakage from Gas Mains.—Purification of Oxide of Iron in situ.—Societe Technique de l'Industrie du Gaz en France.—The Production of Sulphate of Ammonia.

The Belgian Association of Gas Managers have decided to hold an exhibition of coke heating appliances, with the object of stimulating the demand for that product, by bringing before the public a collection of the best appliances for its use. The stoves used for exhibition are first to be submitted to certain tests, and all that satisfactorily pass this criterion are to be exhibited free of cost to the owners, at some convenient place in Brussels, during the last four months of the present year. Jurors are to be selected by the Association, and the decisions of these gentlemen will be published before the exhibition opens—an excellent improvement, by-the-way, on the usual plan of not appointing the jurors until the close of the exhibition. Prizes to the value of £240 are promised. The organizing committee comprises the President of the Association and four prominent members, all occupying important positions in connection with the Belgian gas industry.

This enterprise, in connection with the most important bye-product in gas manufacture, is refreshing as compared with the indifference generally prevailing amongst the principal producers of gas coke in this country, who, for the most part, are satisfied to get rid of it for what it will fetch. Very large quantities are frequently sold to dealers at absurdly low rates, with the result that the whole of the country is deluged with cheap coke, and in small country towns, where, in the absence of competition, the limited production of gas coke could readily be disposed of at prices nearly equaling that of the current rates for coal in the district. The value obtainable is forced down, sometimes as much as one-half, by the influx of large consignments from a distance. Some years ago one of our principal gas engineers (I think it was Mr. Warner, of South Shields) showed that if each gas consumer used only a few hundred weight of coke per annum the whole of the surplus could readily be disposed of in the district. And there are noteworthy cases of gas managers having a large production of coke to dispose of who successfully

realize good values for the same in their own district, even in the face of active competition. Coal is cheaper than it used to be, and there is the increasing production of coke; so in any case we must expect some depreciation in market values. But this depreciation has been of late years considerably greater than is explainable by those causes, and I cannot account for it in any other way than the prevalence of the plan of selling coke at a take-it-away price, sometimes, and not unfrequently, with the proviso that it shall not be offered for sale within a certain distance of the seller's works. Thus some tritling and temporary advantage is secured, regardless of the fact that some other gas undertakings are seriously injured. Such a rash and mistaken policy cannot but result in an all-around levelling down of coke values in which those who practice it must inevitably share. And the general popular opinion respecting its value will diminish until at last it will be regarded as a refuse product, like breeze and cinders. Of course, the price obtainable in Belgium for coke is higher than that current here, and therefore a larger margin is available for a return on any expenses in the way of advertising it. For all that there is plenty of room for an enterprise of a similar nature in many of the large towns in this country. In Paris the gas company has always made a special department of the coke sales, including the introduction of suitable stoves for its consumption.

As there is a difficulty in disposing of ammoniacal liquor in small, out-of-the-way country towns, the following bit of information, contributed by "J. F." to the correspondence columns of the *Journal of Gas Lighting*, is worthy of reproduction: "It has been employed at Brackley, in Northamptonshire, on grass and other lands for the last two years with very good results. I induced a farmer to give it a trial on a piece of land near the gas works, and there is now on the land where the liquor was applied about the heaviest crop of grass to be seen in the neighborhood. He is so pleased with it that this year he has taken the whole stock of liquor." I have myself applied ammoniacal liquor to grass lands with very satisfactory results, and for several years the portion of the field that had been treated with the liquor was sharply defined by the luxuriance of the grass growing upon it, as compared with other parts of the field. The liquor was diluted with three or four parts of water, and applied by means of an ordinary road watering cart. The dilution is necessary to guard against the corrosive influence possessed by the sulphide of ammonium present in the liquor, which otherwise might wither the herbage; and it is possible that the neglect of this precaution in some cases may have brought ammoniacal liquor into disrepute with farmers.

A system for the detection of leakage from gas mains, devised by M. Rattier, has recently attracted a great deal of attention in France. The essential point of novelty is the adoption to the ordinary india rubber bag, used for temporarily plugging main pipes, of two tubes, each passing through the substance of the bag in two places, viz., at the point of greatest diameter and near the neck. They are sufficiently small to pass the plug hole by which the bag is introduced, and are situated on opposite sides. They thus furnish a direct communication from the interior of the main on each side to the exterior, and they can be coupled up to a meter or other indicator. The object of this arrangement is obvious. A section of main having been selected for experiment, the end of it farthest from the gas supply is plugged by any of the usual methods. At the other end one of the special bags is introduced, and the india rubber tubes furnish a communication both with the live main and with the section under test, and thus avoid the necessity of drilling special holes for that purpose. The pipe from the live main is then connected to the inlet of a meter, and that leading from the section to be tested to the outlet. By means of this system the mains could be tested without drilling any additional holes whatever, the nearest service pipe being used for the introduction of the rubber bags. It is especially easy of application when laying branches from a live main, the gas being allowed to follow each section at the close of the day, and thus the pipes could be proved before being covered up. In a similar manner it is very useful for testing services. By the aid of two or three of M. Rattier's bags the system can be readily modified to suit particular circumstances. It is imperative, of course, that the bags and tubes should be thoroughly sound, and this can be easily proved.

A new notion for the revivification of oxide of iron *in situ*, and without shutting off the gas, has recently been the subject of an experiment at Blackburn, conducted by Mr. Ogden, the manager of the gas works, and Messrs. Dempster, of Elland. For some years past the practice of admitting a trifling percentage of air to mix with the gas at some point anterior to the purifiers, for the purpose of prolonging the life of the oxide purifiers, and obviating the nuisance which arises when they are opened, has existed. But the objection has been that only the oxygen is absorbed in the purifiers, the nitrogen serving to dilute and depre-

ciate the gas, and necessitating the use of an additional quantity of canal to keep it up to the mark. Mr. Hawkins, as is well known, has attempted to meet this difficulty by carburetting the air before using it, and his process has attained some degree of success. Mr. Ogden, having learned that "Brin's Oxygen Company" had succeeded in producing pure oxygen for 66 cents per thousand cubic feet, decided to try that product instead of air. With pure oxygen there is the advantage that the whole of the extraneous gas admitted will be absorbed in the purifier, and if a slight excess should escape and pass on with the gas the result will be advantageous rather than otherwise, for it has been observed that the presence of not more than one per cent. of oxygen in coal gas improves its quality. The experimental apparatus comprises two purifiers, each 6 feet square, and special arrangements for admitting the oxygen in the proportion of one cubic foot to each 100 cubic feet of gas. About one million cubic feet of gas have already been treated, with highly satisfactory results. The oxygen has been brought from London, in a compressed state, contained in wrought iron vessels.

The annual meeting of the Societe Technique de l'Industrie du Gaz en France was held at Nancy, a fortnight since. The President, M. Alavoine, made the question of the gas supply of Paris, and the efforts that have recently been made by the municipality to introduce regulations as to the constitution of the same, the principal subject of his inaugural address, especially discussing the proportion of carbonic oxide usually present in coal gas, which had been assumed by the authorities to run as high as 10 or 12 per cent., whereas about 6 per cent. would be nearer the mark. I alluded to this subject in my letter which appeared on May 2. Some members of the Municipal Council appear to have had their attention directed to some experiments made in Germany, which go to show that the characteristic odor of gas is removed by filtration through a quantity of soil, and also to the fact that many cases of poisoning with water gas had occurred in America on account of the large proportion of carbonic oxide gas present in it, and they consequently fear that there is some risk of "deodorized" gas finding its way into houses from leakage in the mains, and poisoning the inmates by means of the carbonic oxide present in it. They wish to limit the proportion of carbonic oxide to something less than 4 per cent. An interesting array of papers was presented for the consideration of the meeting. A prize of 500 francs was awarded to M. Lucien Monnier, manager of the gas works at Saint-Jeand'Angelly, for his memoir entitled, "A Theoretical Study of the Flow of Gas in Long Pipes." Another memoir, on the subject of the "Condensation and the Washing of Gas," is to be converted into a communication by the author, whose name is not given.

In the report of the chief inspector under the Alkali, etc., Works Regulation Act, for the year 1886, it is stated that the total production of sulphate of ammonia throughout the year in the United Kingdom was 106,610 tons, of which gas works produced nearly four-fifths, and shale works the greater part of the remainder. Only about one-fifth is used for agricultural and chemical purposes in this country, the remainder being exported, principally to Germany. The chief Inspector (Mr. A. E. Fletcher) expresses a hope that English farmers will soon learn the value of this article as a manure. It is produced in all parts of the country, and must necessarily be more valuable in the immediate neighborhood than when loaded with heavy charges for carriage. Considerable attention is devoted to the Claus process for the production of pure sulphur from the fumes which are the residue from the manufacture of the sulphate of ammonia, as a means of turning the sulphuretted hydrogen to some useful account, the plant in use at the Leicester gas works being illustrated as an example. This is an interesting specimen of a modern sulphate plant on a large scale, its capabilities being nearly 40 tons per week. The sulphur plant comprises a small kiln or furnace, a condensing chamber 33 feet long by 12 feet wide, a long brick flue of large size, and an oxide purifier, 13 feet square.

Artesian and Gas Wells.

The *Scientific Press* says that within a radius of ten miles in and around Stockton, Cal., there are a goodly number of artesian wells, and an accompanying cut gives a view of the artesian well situated on the Cutler Salmon farm, 7 miles south of Stockton. It is 1,250 feet deep, and discharges 300 gallons a minute from a 7-inch pipe. In sinking, at 280 feet the auger passed through a layer of timber and rotten debris 20 feet thick.

From this point the water was dark colored, brackish, and unfit for use. When the well was finished the water rose 22 feet above the surface, and it was by accident discovered that this great volume of water was strongly impregnated with gas. A gasometer has been placed in the building, shown in the cut, and light and fuel are supplied for the resi-

dence. In the winter season the gas is kept burning all night. At a depth of 800 feet the water is tapped and brought to the surface in an independent pipe. This is a mineral water, and has been found very valuable as a remedial agent in the treatment of rheumatism, gout, and kidney complaints.

ITEMS OF INTEREST FROM VARIOUS LOCALITIES.

CREOSOTED BRICK FOR STREET PAVEMENT.—Many experimenters have endeavored, and with more or less success, during the last decade, to so treat red brick that it might be profitably employed as a material wherewith to pave roadways. The technical journals frequently contain reference to the attempts of this or that inventor to compass the desired end, but we are not aware that any special prominence has been accorded to the results obtained at Nashville, Tenn., by Mr. W. T. Watson, who it would seem has at least satisfied the Board of Public Works of that city that the Watson creosoted bricks answer the requirements needed in the construction of a satisfactory street pavement. Early in the present year Messrs. Ewing (Chairman) and Nestor, of the Nashville Board of Public Works, made a report regarding a specimen section of public roadway that had been put down by Mr. Watson, and, thinking that gas men will, for obvious reasons, be interested in the premises, we herewith reproduce the verdict of the Commissioners: "Nearly two years ago Mr. W. T. Watson, engaged in the business of roofing, paving, and the distillation of coal tar, stated to us that he had for years been carefully experimenting on creosoted brick as a material for street paving, and believed he had succeeded in so charging every pore of medium-quality bricks with coal tar that these were rendered practically indestructible as to wear; moreover, that bricks so treated became impermeable to all liquids, deleterious or otherwise. The Board thereupon allowed him, as an experiment, to cover with the creosoted brick the space at the intersection of Union and Cherry streets, including the treadway of the street railroad. That point, besides being perhaps the most traveled over of any in the city, presented a further obstacle to the life of a street pavement, in that the roadway is very narrow. Mr. Watson carried out his agreement, and the path was given over to the effects of ordinary, everyday travel. Recently the experimental section was thoroughly cleaned off and carefully examined, whereupon it was ascertained that the constant wheel-friction had not only not occasioned any abrasion of the bricks, but also no wheel marks were visible. In fact the wear and tear to which the road had been constantly subjected for nearly two years appeared simply to have polished the treated bricks, and caused them to deaden the rumble of vehicles which passed. The footway followed by the street railway horses exhibited but very little sign of wear. It is our judgment that the experiment of laying street pavement with creosoted brick is an entirely successful one, and we hope in the near future to witness a trial of the experiment on a more extended scale. It seems to us that this brick is to be the paving material of the future. The filling of the pores of the brick with boiling pitch apparently toughens the clay material, serving to remove the ordinary brittleness of burnt clay when the latter is subjected to great pressure. It being impervious to all liquids, while non-treated brick is not, is a feature of great value in a sanitary point of view. Durability, healthfulness, and noiselessness may, we think, be safely claimed for this new style of pavement." Perhaps gas men might do well to inquire more closely into the merits of the Watson process, for certainly the Nashville Board of Public Works seem to be believers in its merit.

OLD WOODEN WATER PIPES IN MONTREAL, CANADA.—A while ago we noted that the Montreal Gas Light Company proposed to extend and perfect its system of gas mains in the Cote St. Antoine district of that city. This work is now in progress, and during the course of the necessary excavation work a long line of disused wooden water pipe was observed. The pipes are about 12 ft. in length, one end being bound with a iron ring, the other extremity being somewhat pointed or tapering. The wood material (chiefly spruce) was in good preservation. A correspondent, in calling our attention to the fact, writes: "Considerable curiosity has been evinced as to how and when these pipes were laid, and I send you the following, from 'Sandham's Montreal, Past and Present,' in explanation. On page 83 of his book Sandham says: 'Great inconvenience had been felt by the inhabitants of the town from the scarcity of the water supply, the whole of which had either to be drawn from the river or from the town pumps in Place d'Armes, Market Place (now Custom House Square), Jesuit's Garden, near the Court House, and other points. In addition to the inconvenience was the necessity for a more copious supply in case of fire. To meet this want, on April 8, 1801, an act was passed constituting Jos. Frobisher, Jno. Gray,

Daniel Sutherland, Thos. Schielfelin and Thos. Sewell a company for supplying Montreal with water. They were authorized to erect buildings and lay down pipes within the city, and were to raise £8,000 among themselves, but should this not prove sufficient for the work, they were to raise a further sum of £4,000, but no proprietor was to hold more than 16 shares in the first and 8 in the second. The act vested in the company the exclusive right for 50 years, but the main pipes were to be laid before 7 years. The plan proposed by the company was to supply the city from a source in the rear of the mountain, and with this in view they expended large sums of money in laying down wooden pipes. But the supply of water was so scanty and the rude pipes so liable to leak and burst, that they failed to carry the plans into successful operation, and the charter was subsequently sold to another company." If Baunister and his associates could but take a look over the present gas and water supply of Montreal perhaps they might be forgiven for suggesting that they were the "original Jacobs," after all.

HOLYOKE, MASS., TO BE LIGHTED BY ELECTRICITY.—Something over a fortnight ago the local street lighting committee voted to accept the terms offered by the Holyoke Electric Light Company for furnishing public lights for a period of three years. The Company agrees to maintain 68 or more arc lights (to burn until midnight) at 37½ cents each per night, 50 cents to be paid for all-night lights. Last year the rates were 45 and 60 cents respectively.

THE TRANSFER COMPLETED.—We understand that the details concluding the transfer of the old Manchester (N. H.) Gas Light Company's plant to the promoters of the Peoples Gas Light Company were perfected on July 8. The new Company organized by electing Mr. John B. Varick to the Presidency, Mr. Frank Dowst having been chosen Vice-President. Mr. Africa has been named as Superintendent.

THE OUTCOME AT DECATUR, ILLS.—After two years of legal warfare, lines of battle at various times being drawn in the Circuit, Appellate, and Supreme Courts, the proprietors of the Decatur Gas Light Company have at last achieved a decisive victory, the "enemy" having been routed in the final contest before the Decatur City Council. The matter was about like this: The Company had been charging the city and ordinary consumers at the rate of \$2.15 per thousand cubic feet of gas consumed, and no particularly great objection was made to the charge. Some malcontent, however, discovered that the ordinance under which the Company operated contained the stipulation that gas should be sold at a price identical with the one which ruled in Springfield, Ills., the prevailing rate there being \$1.50 per thousand. By the way, that sort of bargain is not in as great favor now as was formerly the case, and a rather risky one it is in any event. For instance, the original obtainers of the Decatur grant pledged themselves not to exact a higher gas rate than that made in Springfield (39 miles west of Decatur), the promise being given at a time when, presumably, the two places were governed by something like similar commercial conditions; but, from one cause or another, Springfield progressed more rapidly than did its neighbor, and at the time of the malcontent's discovery the Springfield gas makers were selling annually 500 per cent. more gas than that sent out by their Decatur brethren. Despite the disparity, the Decatur man wanted his pound of flesh, but we are happy to add, owing to the action of Council, he had to be satisfied with a pound that contains, say, 8 ounces. Well, the malcontent roused his fellows, the result being that several consumers refused to pay in excess of \$1.50, and the matter was brought to the attention of the courts. When the Supreme Court stage was reached, that accumulation of the law decided that the Springfield price must govern. Not disheartened over the decision, the Company appealed to the Council, who, strange to say, listening to the voice of right and justice, consented to the repeal of the old ordinance, and the institution of a new agreement. Under the provisions of the new franchise the Company is authorized to charge \$2 per thousand to ordinary consumers, a discount of 25 per cent. being granted to those whose monthly bills show the consumption in that period to have been at or over 45,000 cu. ft. Of course, this enables the city to secure its gas supply at the rate of \$1.50. We congratulate the Decatur gas men on their pugnacity, to which we feel bound to add a word of praise in favor of the local Council. Indeed, the Decatur Council seems to be an exceptional body, for they appear to have some regard for other people's property.

A WAIF FROM WORCESTER, MASS.—Work on the new holder to the order of the Worcester Gas Light Company is being vigorously prosecuted. Although we mentioned something about it at the time it was determined to build the vessel, we may say that it is to have a capacity of

400,000 cu. ft., and that the proprietors of the Continental Iron Works (Brooklyn, N. Y.) are the constructors. In excavating for the tank a rather bad bed of sand and gravel was encountered, but good sheeting and careful engineering finally triumphed. The holder will be completed in time for the busy season of the coming winter. While talking of Worcester affairs, we are happy to be in position to say that Agent Rollins is rapidly recovering from a sickness which at one time appeared alarmingly dangerous.

ANNUAL MEETING, COLUMBUS, GA.—At the annual meeting of the stockholders in the Columbus Gas Light Company the following officers were chosen: President, T. E. Blanchard; Sec. and Treas., Amory Dexter; Supt., E. H. Jenkins; Directors, T. E. Blanchard, A. Dexter, C. B. Grimes, D. F. Wilcox, and W. L. Clark.

A LINE FROM LOUISVILLE, KY.—Another act in the Louisville gas drama (or farce) was completed on July 13th, the stage having been set in the office of Mr. Chas. R. Long. The "lines" called for the election of a board of officers to control the affairs of the Citizens Gas Light Company during the ensuing year. After considerable "prompting" the following were chosen: President, C. R. Long; Vice-President, J. M. Atherton; Directors, W. R. Ray, A. H. Barret, B. Bloom, A. P. Humphreys and E. W. Herman. The capital stock, which was formerly \$1,000,000, was reduced to \$50,000 "by the unanimous desire of the board."

DID NOT LIKE GAS METERS.—R. S. Clifford, a jeweller, living in Lowell, Mass., was arrested at the instance of the Lowell Gas Light Company for having tampered with a gas meter that was supposed to register the gas consumed in defendant's shop on Shattuck street—that is, the meter would have registered the gas were it not for Clifford's ingenuity. Defendant was also a firm believer in the utility of gas as an agent for domestic purposes, for it was subsequently discovered by the Gas Company's inspector that Clifford, by means of a false connection, had been using gas for cooking in the kitchen of his residence, the latter being located on Mt. Vernon street. It is needless to add that he paid as much for gas on Mt. Vernon street as he did on the Shattuck street site; the price being *nil* in both instances. Perhaps the neatest one of his swindling operations was that in which he managed to tap the telephone circuit of the local telephone company, and actually maintained a private exchange of his own, using a queerly-contrived switchboard devised by himself. Look at him in any light, Clifford must be regarded as an ingenious rascal, but we imagine that by the time he is through with the Lowell Gas Light Company that corporation will have convinced him that honesty is the best policy, after all.

WHAT DOES ELMIRA (N. Y.) WANT WITH ANOTHER GAS COMPANY?—On July 13th articles incorporating the Elmira Illuminating Company were filed at the office of the County Clerk. The following are named as the incorporators: Messrs. J. A. Reynolds, J. M. Shoemaker, J. B. Stanchfield, H. E. Baker, W. M. Clark, J. A. Woods and F. H. Leonard, Jr. The avowed object of the Company is to furnish gas and electricity for illuminating and motor purposes, and the capital stock is placed at \$200,000.

IN ORDER to better serve the convenience of the gas consumers of Louisville, Ky., President Morris has ordered that the city be divided into two collection districts, Fourth avenue being selected as the separating mark. In the district east of the avenue gas bills will be presented on the first of the month, while those in the western division will fall due on the 15th. This arrangement is intended to give all a fair chance to secure the rebate or discount which holds good but for five days from the presentation of the monthly account.

THE SUPREME COURT (N. Y.) AND NAPHTHA GAS.—We reproduce the following Associated Press despatch, dated "Middletown, N. Y., July 14: The General Term of the Supreme Court, Part II., in session at Poughkeepsie, has just handed down a decision affirming the verdict of the lower court in a novel and important case relating to the manufacture of gas from naphtha. Margaret Bohlen, whose dwelling adjoins the manufacturing plant of the Port Jervis Gas Light Company, brought suit, in the Supreme Court of Orange County, against the Company to recover damages for alleged injuries to the health and comfort of herself and family, and for the depreciation of the value of real estate caused by the noxious fumes exhaled in the process of manufacturing illuminating gas from naphtha. On trial of the cause, at the May term last year the jury found, as a matter of fact, that the plaintiff had suffered injuries by the noxious fumes from the gases complained of, and the jury assessed the damages at \$340, whereupon Judge Cullen, who

was on the bench, on motion of plaintiff's attorney, granted an injunction restraining the Company from continuing the manufacture of naphtha gas to the detriment of the plaintiff. The defendant subsequently obtained a stay of the injunction on appeal by giving bonds to answer all damages. The appeal now stands overruled, but the case will be probably carried to the higher tribunal for the adjudication of issues of far-reaching public concern."

MR. GARRET CHOSEN A DIRECTOR.—The annual meeting of the Consolidated Gas Light Company (Balt., Md.) was held on July 18. The ballot for officers brought out the largest vote ever known in the history of the Company, 46,908 shares being accounted for. The only change made in the *personnel* of the board was that Mr. Robt. Garret was selected to succeed Mr. A. Jenkins, who declined a re-election. Organization was effected in the following manner: President, Capt. Jno. W. Hall; Secretary, Col. L. R. Smoot; Treasurer, C. F. Peregoy. It was broadly hinted that Mr. Garret is still a large holder of Consolidated stock, and, having severed his connection with the Chesapeake and Equitable Companies, that he will lend his assistance entirely to the interests of the Consolidated Company.

ATLANTA (GA.) GAS STOCK.—In our last we noted that the authorities of Atlanta wished to dispose of enough of the stock owned by the city in the Atlanta Gas Light Company to insure the erection of a high school. The bids (2 in number) were opened at noon of July 18, and the sellers were surprised to find that Mr. J. M. Alexander offered to buy 100 shares at \$15 per share, while Messrs. Pratt & Jones, local bankers, offered \$17 a share for the lot. The officials thought that the offered prices were altogether too small, and some of them urged that the city should dispose of all its gas share holdings. Mr. Hemphill, who favored the latter project warmly, offered the following: "*Resolved*, That the Finance Committee and the Mayor sell, at private sale, all the gas stock owned by the city of Atlanta, and that \$25,000 of the amount received be turned over to the Board of Education, for the erection of the high school, as heretofore appropriated. The amount that is left to be held by the Committee, subject to the order of the General Council." The resolution was adopted, and Atlanta will soon be rid of the golden goose. The "private sale" portion of the resolution looks peculiar.

GREENFIELD (MASS.) GAS MATTERS.—The annual meeting of the Greenfield Gas Company was held on July 21. Mr. S. O. Lamb, who has been Clerk and Treasurer of the Company for over a quarter of a century, refused a re-election, and Mr. W. R. Howland was appointed in his place. The directors chosen were Messrs. F. R. Allen, W. B. Washburn, F. A. Pond, D. Malone, J. B. Hatch, and J. D. Safford. A committee was selected who were instructed to inquire about the wisdom of establishing an electric light plant in connection with the gas supply. It was also voted to reduce the price of gas from \$2.75 to \$2.50 per thousand cubic feet, prompt payment to entitle ordinary consumers to a rebate of 5 per cent., said discount to be increased to 10 per cent. where the consumption equaled 15,000 cubic feet per month. A special discount is to be granted on all gas consumed in churches.

A LINE OR TWO FROM NORTH ADAMS, MASS.—At the annual meeting of the North Adams Gas Company, a large number of stockholders being present, the following board of officers was chosen: President, W. L. Brown; Vice-President and Treasurer, F. S. Richardson; Clerk, A. D. Cady; Directors, J. Bracewell, W. H. Gaylord, W. L. Brown, E. B. Hamblen, C. Q. Richmond, E. A. Richmond, and F. S. Richardson. The Treasurer's report, covering the operations of the Company during the last fiscal year, showed that Brother Frank had been strictly adhering to business principles in the twelvemonth, for the sendout showed a gain over last year of something like 11 per cent. New mains are being put down in East Quincy and Brooklyn streets, and the usual amount of renewal work is underway.

NEW GAS COMPANY.—The Greely Gas and Coal Company, of Greely, Kansas, has been incorporated. Those interested in the enterprise are Messrs. W. F. Priest, J. B. Carley, C. H. Lathen, N. S. Endsley, Eli Truefitt, and H. Walker.

DOWN AGAIN, AT NASHUA, N. H.—That Honorable gas man who is in charge of the fortunes of the Nashua Gas Light Company once more appears in the ranks of the reducers, for we note that hereafter gas is to be sold there at the rate of \$1.40 per thousand cubic feet. If we mistake not this is equivalent to a reduction of 20 cents, and may perhaps give Supt. Norton facts and figures wherewith to further entertain the New England Association. The Nashua *Daily Telegraph*, in alluding to the con-

cession in gas rates, makes the following editorial comment: "We desire to renew, in a public way our repeated commendation of the Nashua Gas Light Company. It has made another voluntary reduction in rates, this time dropping to \$1.40, which is a lower figure than that ruling in any other city in New England, that is not three times as large as Nashua. If railroads were run as this corporation is run, the present scheme of monopoly and aggrandizement would not be witnessed in our State." We submit that the above sounds decidedly like "honorable mention."

SOMETHING FROM FOSTORIA, OHIO.—Brother J. Gwynn, Supt. of the Illuminating Department of the Northwestern Ohio Natural Gas Company, with headquarters at Fostoria, has been on the sick list, but his physical depression does not seem to have prevented him from "keeping close to the leaders" in the march of progress. That decision is based on the contents of the following circular, issued from the Company's office, on date of June 8. The circular reads: "During and after this month rates for manufactured illuminating gas will be as follows: For a consumption of less than 2,000 cubic feet per month, \$2 per thousand; over 2,000 cubic feet per month, \$1.80 per thousand. Gas used in summer in cooking stoves, \$1.50 per thousand, provided not less than 500 cubic feet are consumed. These rates will be subject to the usual discount of 10 per cent., if bills are paid at the office on or before the 10th of each month." Possibly the publication of this pronouncement acted as a sort of "heroic remedy" in the matter of routing Bro. Gwynn's illness. At any rate, we are glad to say that he is himself once more.

STREET LIGHTING AT JACKSON, MICH.—We are indebted to Mr. W. M. Eaton, Treasurer and Supt. of the Jackson Gas Light Company for the knowledge that the local authorities are inclined to give the lighting of the streets exclusively to the electricians. In passing we may say that under the present contract, which will soon expire, the city is lighted by about 40 arc lights (Messrs. Jarvis and Foote being the contractors, and they employ the Thomson-Houston system) and 125 gas lamps, the price paid for the former being 33½ cents per night, the gas company receiving \$2 per thousand for gas supplied. The lights burn all night and every night. The Council having called for bids for the future lighting of the city, the following proposals were received:

No. of Lights.	Jarvis & Foote.	Markle Engineering Co.
180.....	\$16,425	\$12,483
160.....	15,520	11,680
130.....	13,000	9,964
100.....	10,000	8,030
80.....	8,960	6,716

The bids were based on a 5-year contract, with the understanding that 2,000-candle power lights were to be furnished. The Markle Engineering Company, whose home office or headquarters is at Detroit, owns the Edison plant at Jackson, and therefore would have to do considerable construction work before it could proceed with the lighting. Both companies (their proposals as given above promised that all-night lighting would be called for) submitted a sixth proposition in reference to the demand of the city for 100 lights, to burn on not less than 15 nights and not more than 20 nights each month, and not less than 4 or in excess of 8 hours each night. Messrs. Jarvis & Foote said: "If the 100 lights are operated in connection with the 80 contemplated in the fifth proposition, the price to be 5 cents per hour per lamp, additional; if run independent, 8 cents per hour per lamp—in either case lamps to burn at least 1,200 hours per annum. Should they be burned 1,440 hours or more per year, 4½ and 6 cents, respectively. We will furnish the lamps as above on a five-years' contract, the same to be subject to review by each succeeding Council during the first 30 days of their existence." The Markle Company, in respect of the sixth proposition, said: "Three cents per hour for the time actually in use." Having read the proposals the Lighting Committee recommended the passage by the Council of the following peculiar resolution: "*Resolved*, That the Lighting Committee be authorized to make arrangements with the Markle Engineering Company to put up 25 test lights to run for 30 days. If this Company is finally awarded the contract to furnish the city with electric light, then the price shall be 19½ cents per light per night; if the Council should not conclude to award them the contract, then the price shall be 23 cents per light per night." The resolution was adopted without debate, which shows that the Jackson Council is not inclined to make a very hard fight over the fact as to whether the city shall pay 19½ cents or 23 cents per night per light. Under the existing contract the city pays about \$9,000 per annum for street lighting. It will be noted that the Jackson Gas Company did not bid at all, and Mr. Eaton explains that by saying: "We would have bid (on from 200 to 400 gas lamps) at a very low figure if any chance existed for us to secure an award; but as our Councilmen

are all very much in favor of arc lighting, we were convinced that it would be useless to submit any figures. In addition to the two electric light companies our city (it has a population of 20,000) will soon have two gas companies, for the National Gas Light and Fuel Company, of Chicago, Ills., is putting up a plant here. Hence, you see, Jackson will soon hold 'two pair,' and if natural gas should also be found, why, we would have a 'full hand.' The gas well is down 1,800 feet, and no gas as yet; but the contractor says the indications are good. I agree with him—that is, I think the indications are good for him to be paid to drill deeper."

THE NEW ROOTS EXHAUSTER.—By referring to the advertising card of the Messrs. P. H. & F. M. Roots, in this issue of the JOURNAL, it will be seen that they have at last completed their new exhauster, which is constructed on principles that differ entirely from those that governed the make-up of their old-style instrument. The Messrs. Roots claim that their new exhauster is as superior to their old-style of apparatus as that was superior to the general run of exhausters coeval with it in the market.

BROTHER BOARDMAN GETS THERE.—It has been matter of common rumor for some time back that certain financiers were anxious to supply the city of Macon, Ga., with a duplicate gas and water plant. Of course, that is nothing unusual in itself, for speculators are, as a rule, anxious to take advantage of the efforts of the pioneers who have built up a prosperous trade by dint of hard labor and unremitting attention; but as Supt. Boardman is not the man to sit idly by while others are attempting to wrest from him the fruits of his toil and intelligence, we imagined that when the proper time came the speculators would feel that they had not properly estimated the home strength of the old Macon Gas and Water Company. They know something about it now, however, for the city has recently entered into an agreement with the Company to keep up the water supply for a further period of 5 years from the expiration of the present contract. Good enough!

IMPROVEMENTS AT BIDDEFORD, MAINE.—Regenerative furnaces are to be put up in the plant of the Saco and Biddeford Gas Light Company.

GAS MATTERS AT FORT SCOTT, KANSAS.—Mr. L. K. Scofield seems to think that he has borne a trifle too heavy a responsibility in carrying on the financial affairs of the Fort Scott City Gas Company without assistance. At least we judge so from the fact that on the 1st inst. the ownership of the plant, franchises, etc., was vested in a joint-stock company, which is officered as follows: President and General Manager, L. K. Scofield; Vice-President, J. A. Durkee; Supt., E. W. Morse; Directors, L. K. Scofield, J. A. Durkee, W. Chenault, B. E. Langdon, and J. D. McCleverty. Supt. Morse has done yeoman's work under the direction of Mr. Scofield, and we are pleased to observe that Mr. Scofield's confreres have determined to retain Mr. Morse's services. Another important move made in the Company's affairs is the determination to take advantage of natural gas as an aid to coal gas, which determination resulted in the purchase, from the American Gas Improvement Company, of Pittsburgh, Pa., of the right to use the McKay-Critchlow process. [For a description and statement of results secured from this process see *ante*, p. 72.] The adoption of this process in the Fort Scott plant necessitated a considerable expenditure, but when everything is completed the Company will be in position to meet the draughts of all consumers. This last leads us to remark that the Company, in order to satisfy the rapidly increasing demands for gas from the citizens, has put down some 10 miles of gas mains during the present season, and that extension, perhaps more than anything else, will convince our readers that Mr. Scofield really needed help in carrying on the gas supply of his city. The finished gas product at Fort Scott will hereafter contain about 33 per cent. of treated natural gas.

TO BE ABSORBED.—It is more than likely that the proprietors of the Westfield (Mass.) Gas Light Company will purchase a controlling interest in the local electric light company.

HOME AGAIN.—Mr. Jas. Somerville, Engineer to the Indianapolis (Ind.) Gas Light Company, is once more in harness, and is quite pleased with the experiences gained during his recent European journeyings. In a letter to us announcing his arrival home Mr. Somerville says: "I had a most pleasant time. I visited Beckton and the new East Greenwich works, and ascended to the top of the 9,000,000 cu. ft. capacity holder which is being built there. What I saw looked to me more like boiler making than gas holder work. I also had the good fortune to

meet Mr. Carpenter, of Vauxhall, who kindly showed me one of his furnaces, which heated six benches of retorts. * * * I also visited one of the Scotch works, where they were making 30-candle gas. I saw no electric lights in London, save in one or two of the club houses."

PUBLIC LIGHTING AT OAKLAND, CAL.—As intimated by a correspondent in our last issue, the authorities have awarded the contract for public lighting to the Oakland Gas Light and Heat Company. Under the agreement the Company is to furnish gas to the 872 street lamps now erected in the city, and for any other lamps ordered erected, at the rate of 10½ cents per lamp per night. Gas is to be furnished for city buildings at 50 cents per 1,000 cu. ft. less than that charged to private consumers, but the rate for same is never to exceed \$2.50 per 1,000. The contract is to run for two years.

IMPROVEMENTS AT NORTHAMPTON, MASS.—A new bench of 5's is being added to the plant of the Northampton Gas Company.

ANNUAL MEETING, FALL RIVER, MASS.—At the annual meeting of the Manufacturers Gas Company, of Fall River, the following officers were elected: President, C. M. Shove; Clerk and Treasurer, J. A. Baker; Directors, F. H. Stafford, C. M. Shove, J. A. Baker, A. Brayton, F. H. Dewelly, and C. M. Hathaway.

ANNUAL MEETING, BINGHAMTON, N. Y.—At the annual meeting of the Binghamton Gas Light Company the following officers were chosen: President, J. W. Manier; Vice-President, J. C. Phelps; Secretary and Treasurer, W. G. Phelps; Directors, J. C. Phelps, G. S. Sessions, W. G. Phelps, S. J. Hirschmann, C. W. Stone, N. A. Phelps, and J. W. Manier.

The Capital Gas Company, of Sacramento, Cal., now operating the Thomson-Houston system, has purchased a 50-light plant of the Waterhouse type. Sacramento gas men are quite busy at present.

Correspondence

[The JOURNAL is not responsible for the opinions expressed by correspondents.]

How Should the Flow from a Natural Gas Well be Determined?

NEW YORK, July 23, 1887.

To the Editor AMERICAN GAS LIGHT JOURNAL:

Since the advent of natural gas, and the prospect of having it piped from the wells into neighboring cities, I have taken some interest in ascertaining the amount that would be delivered through a given diameter of pipe a given distance. For this purpose I used Professor Pole's formula (page 382, "King's Treatise on Coal Gas"), and compiled quite a number of calculations, putting them away in my notebook for future reference. However, a few weeks ago, on visiting a town supplied with natural gas, and observing the size of the pipes, the distance they ran, and the amount of gas issuing at the point of delivery, I came to the conclusion that my calculations were all wrong, as far as natural gas was concerned. The quantity delivered was at least ten times more than ought to have been delivered according to the formula.

I can, perhaps, partially account for this phenomenon by observing that the gas as it issued from the well was intensely cold—so much so that hoar frost (although the day was warm) collected round a leaky joint. Now, is it not possible that the gas, being at such a low temperature at the point of issue from the well, gradually expanded in volume as the temperature was raised, and, as it were, carried its pressure with it? I shall be glad to know if any of your readers have observed this; and if they have arrived at any accurate method of ascertaining the amount of natural gas delivered, allowing for the difference of temperature, which, in the formula I used, is assumed to be the same.

Yours, etc.,

J. S.

Seeking for Information.

BOSTON, MASS., July 29, 1887.

To the Editor AMERICAN GAS LIGHT JOURNAL:

In the matter of leakage of gas from street mains, *percentages* are so entirely deceptive, varying so much with the amount of business done by different companies and with the seasons of the year, in any case, that I desire to know what amount of leakage per year, *per mile of pipe*, ought to be tolerated by a gas manager? Can any of your subscribers give me any information on this point?

Yours truly,

SUBSCRIBER.



A. M. CALLENDER & CO.,
PROPRIETORS.

Editor—**JOS. R. THOMAS, C.E.**
Asst. Editor—**T. J. CUNNINGHAM.**
Manager—**C. E. SANDERSON.**

PUBLISHED ON THE 2ND AND 16TH OF EACH MONTH
At No. 42 Pine Street, New York.

This is a recognized official organ of—
LIGHT, HEAT, STEAM, WATER-SUPPLY,
VENTILATION, SANITARY IMPROVEMENT,
AND GENERAL SCIENCE.

TERMS

SUBSCRIPTION—Three Dollars per annum, in advance.

AGENTS

NEW YORK—AMERICAN NEWS Co. 39 and 41 Chambers St.
BOSTON—S. M. PETTINGILL & Co., 6 State Street.
PHILADELPHIA—PRATT & Co., Corner 9th and Arch Streets.
England—C. W. HASTINGS, 22 Buckingham St., London, W C
Germany—B. WESTERMANN & Co., of New York

TUESDAY, AUG. 2, 1887.

Protecting Tall Chimneys from Lightning Strokes.

M. Faraday, in a communication to the London *Architect and Builder*, believes that the conductor should be of half-inch copper rod, and should rise above the top of the chimney by a quantity equal to the width of the chimney at the top. The lengths of rod should be well joined metallically to each other, and this is perhaps best done by screwing the ends into a copper socket. The connection at the bottom should be good; if there are any pump pipes at hand going into a well they would be useful in that respect. As respects electrical conduction, no advantage is gained by expanding the rod horizonally into a strap or tube—surface does nothing; the solid section is the essential element. There is no occasion of insulation (of the conductor), for this reason. A flash of lightning has an intensity that enables it to break through many hundred yards (perhaps miles) of air, and therefore an insulation of 6 inches or 1 foot in length could have no power in preventing its lead to the brickwork, supposing that the conductor were not able to carry it away. Again, 6 inches or 1 foot is so little that it is equivalent almost to nothing. A very feeble electricity could break through that barrier, and a flash that could not break through 5 or 10 feet could do no harm to the chimney. A very great point is to have no insulated masses of metal. If, therefore, hoops are put round the chimney each should be connected metallically with the conductor, otherwise a flash might strike a hoop at a corner on the opposite side to the conductor, and then on the other side, on passing to the conductor, from the nearest part of the hoop, there might be an explosion, and the chimney injured there, or even broken through. Again, no rods or ties of metal should be wrought into the chimney

parallel to its length, and, therefore, to the conductor, and then to be left unconnected with it. The rod may be close along the brick or stone. It makes no difference. There will be no need of rod on each side of the building, but let the cast iron hoop and the others you speak of be connected with rod, and it will be in those places at least as if there were rods on every side of the chimney. A three-fourth rod is no doubt better than a half-inch, and, except for the expense, I like it better. But a half-inch has never yet failed. A rod at Coutts' brewery has been put up 1½ inches diameter; but they did not mind expense. The Nelson column, in London, has a half-inch rod—three-fourths is better. I do not know of any case of harm from hoop iron inclosed in the building, but if not in connection with the conductor I should not like it. Even then it might cause harm if the lightning took the end furthest from the conductor.

Coke in Russia.

An Exchange says that, according to a report just published by the Russian Minister of Finance, Russia imported last year a little more than 100,000 tons of coke, being a considerable advance on the total of the two previous years, although only about equal to the quantity entering the country in 1883. Nearly half arrived by the Baltic ports, mainly from England, while the bulk of the remainder was despatched across the Western frontier from Prussia, for the most part to the Vistula manufacturing districts. With regard to the Black Sea ports, only 100 tons were imported in 1883, and 90 tons in 1884. In 1885, however, the quantity jumped to 4,000 tons, and in the following year to 6,000 tons; upon which the Russian Government at once decided to raise the duty. Until quite recently the home manufacture of coke, except in the Donetz region, was very small; but a considerable capital is now being invested in establishing coke ovens, and, favored by the heavy duty, the enterprise promises to be a lucrative one for those concerned in it.

The Market for Gas Securities.

As intimated in our last the city gas share market has reached a point where extreme inactivity characterizes the situation. Towards the close of July Consolidated is reported to have declined to 74½ on an actual sale, but we incline to the idea that although a contract was professedly made at that figure, no shares parted hands. We think so because an order immediately given to purchase 200 shares at 75½ failed to elicit an offering. Undoubtedly some timid owners have parted with their stock at a price below 79, the reason given being that the completion of the works of the Standard Gas Light Company would precipitate a war of rates. It is quite likely that such a conflict may in time be precipitated, but it should be remembered that the latest gas creation of the Legislature, despite the fact that it was born amid the throes of those who were wildly engaged in an attempt to bring the Consolidated Gas Light Company to terms, is in the field to make money, and not to lose it. After war comes peace, so do not let the warriors rob you of a cent's worth of your property. By-the-way, we note that 5 shares Standard Gas Light Company's stock (full paid common, trust company's receipt) was recently sold at auction at 50½, and

it was dear at that. Mutual is very weak, while Equitable fairly holds its own. Brooklyn shares are sluggish; in fact a transfer in them is a rarity. Eastern shares are all firmly held. The rumors regarding a Boston Gas Trust, presumably on the style of the Chicago example, are rife. Old Boston stock is held now in the market at about 204, and it is quite likely to go higher. Baltimore gas matters are very much entangled. We note that Robt. Garret was elected a director in the Consolidated Company of that city, at its recent annual meeting. Recent sales at auction included the following Brooklyn shares: 61 Nassau at 100½; 116 Brooklyn, at 101½; \$1,800 Nassau scrip, at 95; 1 Metropolitan, at 86; 41 Citizens, at 58. Also \$29,000 Somerville and Raritan (N. J.) Gas Company's 6 per cent. bonds, at 41½.

Gas Stocks.

Quotations by Geo. W. Close, Broker and Dealer in Gas Stocks,
16 WALL ST., NEW YORK CITY.

AUGUST 2.

☞ All communications will receive particular attention.
☞ The following quotations are based on the par value of \$100 per share. ☞

	Capital.	Par.	Bid	Asked
Consolidated.....	\$35,430,000	100	73½	—
Central.....	440,000	50	30	—
“ Scrip.....	220,000	—	47	57
Equitable.....	2,000,000	100	120	125
“ Bonds.....	1,000,000	—	113	115
Harlem, Bonds.....	170,000	—	—	—
Metropolitan, Bonds....	658,000	—	110	113
Mutual.....	3,500,000	100	93	96
“ Bonds.....	1,500,000	1000	101	—
Municipal, Bonds.....	750,000	—	—	—
Northern.....	125,000	50	30	—
“ Scrip.....	108,000	—	—	—
Yonkers.....	—	50	—	80
Richmond Co., S. I.	300,000	50	50	—
“ Bonds.....	12,000	—	—	—
Gas Co's of Brooklyn.				
Brooklyn.....	2,000,000	25	101	102
Citizens.....	1,200,000	20	58	—
“ S. F. Bonds....	320,000	1000	—	103
Fulton Municipal.....	3,000,000	100	138	140
“ Bonds....	300,000	—	—	106
Peoples.....	1,000,000	10	61	62½
“ Bonds (5's).....	368,000	—	97	—
“ “ (6's).....	94,000	—	100	—
Metropolitan.....	1,000,000	100	82	84
Nassau.....	1,000,000	25	101	103
“ Ctfs.....	700,000	1000	100	—
Williamsburgh.....	1,000,000	50	125	128
“ Bonds... ..	1,000,000	—	111	—
Out of Town Gas Companies.				
Boston (Mass.) Gas Co.	2,500,000	500	204	208
Buffalo Mutual, N. Y....	750,000	100	90	95
“ Bonds... ..	200,000	1000	95	100
Citizens, Newark.....	1,000,000	50	140	145
“ “ Bonds.	45,000	—	—	—
Chicago Gas Trust.....	25,000,000	100	55½	58
Cincinnati G. & C. Co..	6,000,000	100	187	188
Consolidated, Balt.....	6,000,000	100	52½	52½
“ Bonds....	3,600,000	—	107	107½
Chesapeake, Balt.....	1,500,000	100	75	—
“	1,000,000	—	100	102
Consumers Toronto....	1,000,000	50	192	—
Central, S. F., Cal.....	—	—	80	100
Capital, Sacramento, Cal.	—	—	57½	60
Hartford, Conn.....	750,000	25	140	142
Jersey City.....	750,000	20	168	—
Laclede, St. Louis, Mo.	2,000,000	100	125	—
Louisville, Ky.....	2,570,000	50	130	132
Little Falls, N. Y.....	50,000	100	95	100
“ Bonds	25,000	—	100	103
Montreal, Canada.....	2,000,000	100	220	221
New Haven, Conn.....	—	25	193	197

Advertisers Index.

GAS ENGINEERS.		Page
Jos. R. Thomas, New York City	88	88
Wm. Henry White, New York City	88	88
Wm. Mooney, New York City	88	88
William Gardner, Pittsburgh, Pa.	88	88
GAS WORKS APPARATUS AND CONSTRUCTION.		
James R. Floyd, New York City	91	91
T. F. Rowland, Greenpoint, L. I.	91	91
Delly & Fowler, Phila., Pa.	91	91
Kerr Murray Mfg. Co., Fort Wayne, Ind.	90	90
Stacey Mfg. Co., Cincinnati, Ohio	91	91
Bartlett, Hayward & Co., Baltimore, Md.	81	81
Morris, Tasker & Co., Limited, Phila., Pa.	90	90
Davis & Farnum Mfg. Co., Waltham, Mass.	90	90
R. D. Wood & Co., Phila., Pa.	90	90
Southwark Foundry and Machine Co., Philadelphia, Pa.	90	90
Bonton Foundry Co., Chicago, Ills.	87	87
Smith & Sayre Manufacturing Co., New York City	91	91
PROCESSES.		
National Gas Light and Fuel Co., Chicago Ills	82	82
GAS AND WATER PIPES.		
Gloucester Iron Works, Phila., Pa	88	88
Mellert Foundry and Machine Co., Reading, Pa. (John Fox, Selling Agent, N. Y.)	88	88
Cincinnati and Newport Iron and Pipe Co., Newport, Ky.	88	88
Ohio Pipe Co., Columbus, Ohio	88	88
Pancoast & Rogers, New York City	88	88
M. J. Drummond, New York City	88	88
Wells Rustless Iron Co., New York City	87	87
R. D. Wood & Co., Phila., Pa.	90	90
GAS ENGINES.		
Schleicher, Schumm & Co., Phila., Pa.	64	64
Clerk Gas Engine Co., Phila., Pa.	83	83
RETORTS AND FIRE BRICK.		
J. H. Gautier & Co., Jersey City, N. J.	86	86
B. Kreischer & Sons, New York City	86	86
Adam Weber, New York City	86	86
Laclede Fire Brick Works, St. Louis, Mo.	86	86
Brooklyn Retort and Fire Brick Works, Brooklyn, N. Y.	86	86
Borgner & O'Brien, Phila., Pa.	86	86
James Gardner, Jr., Pittsburgh, Pa.	86	86
Henry Maurer & Son, New York city	86	86
Chicago Retort and Fire Brick Works, Chicago, Ills.	86	86
Baltimore Retort and Fire Brick Co., Baltimore.	86	86
Oakhill Gas Retort and Fire Brick Co., St. Louis, Mo.	86	86
Evens & Howard, St. Louis, Mo.	87	87
Cincinnati Gas Retort and Fire Brick Works, Cincinnati, O.	87	87
Emil Lenz, New York City	87	87
SCRUBBERS AND CONDENSERS.		
G. Shepard Page, New York City	89	89
R. D. Wood & Co., Phila., Pa.	90	90
REGENERATIVE FURNACES.		
Bartlett, Hayward & Co., Baltimore, Md.	81	81
Fred. Bredel, New York City	87	87
GAS GOVERNORS.		
T. C. Hopper, Phila., Pa	84	84
Counelly & Co., New York City	83	83
CEMENTS.		
C. L. Gerould, Manchester, N. H.	86	86
GAS ENRICHERS.		
Standard Oil Co., Cleveland, Ohio	92	92

GAS METERS.		Page
Harris, Griffin & Co., Phila., Pa.	91	91
American Meter Co., New York and Philadelphia	95	95
The Goodwin Gas Stove and Meter Co., Philadelphia, Pa.	95	95
Helme & Mellbenny, Phila., Pa.	95	95
D. McDonald & Co., Albany, N. Y.	95	95
Nathanlel Tufts, Boston, Mass.	91	91
EXHAUSTERS.		
P. H. & F. M. Roots, Connersville, Ind.	82	82
Smith & Sayre Manufacturing Co., New York City	91	91
Wilbraham Bros., Philadelphia, Pa.	83	83
Counelly & Co., New York City	83	83
GAS COALS.		
Penn Gas Coal Co., Phila., Pa.	93	93
Perkins & Co., New York City	92	92
Newburgh Orrel Coal Co., Baltimore Md	93	93
Despard Coal Co., Baltimore, Md.	93	93
Chesapeake and Ohio R.R. Coal Agency, N. Y. City	93	93
Westmoreland Coal Company, Phila., Pa.	93	93
Monongahela & Peters Creek Gas Coal Co., Pittsburgh, Pa.	93	93
CANNEL COALS.		
Perkins & Co., New York City	92	92
J. & W. Wood, New York City	92	92
VALVES.		
Ludlow Valve Manufacturing Co., Troy, N. Y.	81	81
John McLean, New York City	81	81
Chapman Valve Manufacturing Co., Boston, Mass.	81	81
R. D. Wood & Co., Phila., Pa.	90	90
ENGINES AND BOILERS.		
Jarvis Engineering Co., Boston, Mass.	83	83
PURIFYING MATERIAL.		
S. H. Douglas, Ann Arbor, Mich.	87	87
Counelly & Co., New York City	83	83
GAS LAMPS.		
The Siemens-Lungren Co., Philadelphia, Pa.	89	89
G. Shepard Page, New York City	88	88
Albo-Carbon Light Co., Newark, N. J.	79	79
Standard Gas Lamp Co., Phila., Pa.	87	87
PURIFIER SCREENS.		
John Cabot, New York City	55	55
Geo. A. Mills, Baltimore, Md.	87	87
GAS STOVES.		
American Meter Co., New York and Philadelphia	85	85
The Goodwin Gas Stove and Meter Co., Phila. Pa.	96	96
STREET LAMPS.		
J. G. Miner, Morrisania, New York City	47	47
Bartlett Street Lamp Mfg Co., New York City	84	84
BURNERS.		
G. Gefroerer, Phila., Pa.	92	92
STEAM BLOWER FOR BURNING BREESE.		
H. E. Parson, New York City	56	56
GASHOLDER TANKS.		
W. C. Whyte, New York City	87	87
GAS FIXTURES.		
Mitchell, Vance & Co., New York City	84	84
COKE CRUSHER.		
C. M. Keller, Columbus, Ind.	93	93
GAS BAGS.		
Peerless Manuf'g Co., New York City	83	83

ELECTRICAL APPARATUS.		Page
Waterhouse Electric & Manufg Co., Hartford, Conn.	80	80
BOOKS, ETC.		
English Journal of Gas Lighting	79	79
Gas as a Source of Light, Heat and Power	84	84
Goodwin's Directory of Gas Light Companies	92	92
King's Treatise	94	94
Scientific Books	94	94
Management of Small Gas Works	88	88
Newbigging's Gas Manager's Handbook	94	94
Gas vs. Electricity	91	91

Engagement Desired.

The advertiser, an English Gas Engineer, age 25, seeks an engagement
 As Gas Works Manager or Assistant Manager.
 Thoroughly understands the manufacture and distribution of gas, and is a good draughtsman and chemist. Address
 672-6t "H." care this Office.

**FOR SALE,
 Two Sinuous Friction Condensers,**

Each 1 ft. 3 in. wide by 11 ft. 3 in. long, and 18 ft high, of sufficient capacity for 225,000 cu. ft. per day. Apply to
 665-12 PETER COFFEY, Supt. Gas Co., Peoria, Ill.

**ENGLISH
 "Journal of Gas Lighting."**

Issued weekly. New volume commences Jan. 1, 1887. Price, \$7 per annum. Subscriptions taken by

CHARLES NETTLETON, Agent for U. S.,
 No. 115 BROADWAY, N. Y. CITY.

BOOKS.

DISTILLATION OF COAL TAR AND AMMONIACAL LIQUOR.

By GEORGE LUNGE. Price \$8.50.

A TREATISE ON THE COMPARATIVE COMMERCIAL VALUES OF GAS COALS AND CANNELS.

By DAVID A. GRAHAM. 8vo., Cloth. Price \$3.

Orders for these books may be sent to this office.
A. M. CALLENDER & CO.,
 42 PINE ST., N. Y. CITY.

THE ALBO-CARBON LIGHT.

THIS SYSTEM HAS SHOWN ITSELF IN THOUSANDS OF CASES—IN HALLS, CHURCHES, PICTURE GALLERIES, CONCERT HALLS, RESTAURANTS, BANKS, CLUBS, STORES, OFFICES, and PRIVATE RESIDENCES—TO BE THE

Best Adapted and Most Successful Method of Gas Lighting Ever Offered.

The SOFTNESS AND PURITY OF THE LIGHT make it most desirable for Office and Household Uses. Its BRILLIANCY and POWER render it unrivaled for lighting Halls, Churches, etc. Its ECONOMY secures for it general favor wherever used.

NOTICE.—Suits are pending in the United States Circuit Courts in Illinois and Pennsylvania against various parties for infringement of our Letters Patent No. 247,925, dated October 4, 1881, and No. 333,862, dated January 5, 1886. The first of these suits has come up for hearing, and an injunction has been granted therein. The second of said suits has not yet been reached for hearing. All persons are cautioned against manufacturing, selling, or using any apparatus or material which infringes our patents. We intend to prosecute all parties infringing patents owned by us.

ALBO-CARBON LIGHT CO. (Sole Manufacturers for the United States) Main Office, Newark, N. J.



**GASHOLDERS, PURIFIERS, SCRUBBERS, CONDENSERS, EXHAUSTERS,
Bench Castings, Iron Roofs, Lamp Posts,
VALVES, STREET MAIN SPECIALS, ETC.,**

MANUFACTURED BY

KERR MURRAY MANUFACTURING COMPANY.

From 1880 to 1886, inclusive, we erected Gasholders for the following cities, viz.:

Adrian, Mich.	East End Gas Co., Pitts-	Janesville, Wis.	New Castle, Pa.	Valparaiso, Ind.
Akron, Ohio.	burgh, Pa.	Johnstown, Pa.	Niagara Falls, N. Y.	Van Wert, Ohio.
Albuquerque, N. M.	East Saginaw, Mich.	Key West, Fla.	Osawatomie, Kans.	Wabash, Ind.
Altoona, Pa.	Elgin, Ills.	La Crosse, Wis.	Pittsburgh, Pa. (2)	Waco, Texas.
Anderson, Ind.	Evanston, Ills.	Lebanon, Ind.	Plainfield, Ind.	Waukesha, Wis.
Bellaire, Ohio.	Eufaula, Ala.	Lima, Ohio.	Portage City, Wis.	Wheeling, West Va.
Birmingham, Ala.	Frankfort, Ind.	Logan, Ohio.	Sedalia, Mo.	Wellington, Kans.
Bucyrus, Ohio.	Freeport, Ills.	Louisville, Ky.	Sheboygan, Wis.	West Pittsburgh, Pa.
Canton, Ohio.	Galesburg, Ills.	Mankato, Minn.	South Bend, Ind.	Xenia, Ohio.
Circleville, Ohio.	Grafton, West Va.	Mansfield, Ohio.	South Chicago, Ills.	Youngstown, Ohio.
Colorado Springs, Col.	Greensburg, Pa.	Marshalltown, Iowa.	Springfield, Ills.	Ypsilanti, Mich.
Danbury, Conn.	Huntington, Ind. (2)	Meridian, Miss.	Streator, Ills.	
Delaware, Ohio.	Ironton, Ohio.	Minneapolis, Minn.	Topeka, Kans.	
Delphos, Ohio.	Jamestown, N. Y.	Muskegon, Mich.	Uniontown, Pa.	

Under construction, 1887.

Arkansas City, Kans.	Grand Forks, Dakota.	Mobile, Ala.	Santa Fe, N. M.	Fuel Gas and Electric Engi-
Dallas, Texas.	Grand Rapids, Mich.	Pittsburgh, Pa.	Wichita, Kans.	neering Co., Pittsburgh, Pa.
El Paso, Texas.	La Crosse, Wis.	Pine Bluff, Ark.	Lexington, Mo.	Stillwater, Minn.

Estimates, with Plans and Specifications, for new or the rebuilding of old works, furnished on application. Correspondence solicited. Address

KERR MURRAY MANUFACTURING CO.,

A. D. CRESSLER, General Manager.

FORT WAYNE, IND.

ELECTRIC ARC LIGHTING.

OFFICE OF CHURCH & Co.,
129 PEARL ST., N. Y., May 10, 1887. }

THE WATERHOUSE ELECTRIC AND MFG. CO. : Gentlemen—The record of the gentlemen connected with your Company for the production of first-class machinery led us to suppose that the workmanship of your apparatus, from a mechanical point of view, would be all that could be desired. Upon investigation we learned that the plants installed were giving entire satisfaction. The Harlem Lighting Company speak in the highest terms of your system, and certainly the wonderfully steady light produced from their station warrants the endorsement.

On this information we ordered a plant for our factory, and would say that you have fulfilled our expectations. The dynamo is the smoothest and stillest running machine we have seen, and the workmanship is indeed

first-class. The regulator performs its work, for we have run ten arc lights on our 35-light machine without an over-production of current, and with the machine perfectly cool. The exhibition made on starting the plant was as fine a test of automatic regulation as we ever expect to witness. With all of our lamps burning, the machine was connected at the binding posts, instantly cutting out all of the lamps and placing the machine in short circuit, and the machine was run in short circuit until signification was made that we were satisfied.

In fact, your representations of regulation, power required, and steady light we think are well sustained. The light is perfectly adapted for inside illumination. We congratulate ourselves in securing such a fine system of electric lighting, for it is indeed a puzzle, amid all of the stalwart claims of the various systems, to select the best. Yours truly, CHURCH & CO.

A STRICTLY FIRST-CLASS SYSTEM OF ARC AND INCANDESCENT LIGHTING.

MANUFACTURED BY

THE WATERHOUSE ELECTRIC AND MFG. COMPANY,
Factory, Colt's West Armory. **Hartford, Conn.**

To All Whom It May Concern!

The SIEMENS-LUNGREN COMPANY hereby warns the public against the use of various infringing Regenerative Gas Lamps which are offered for sale. This Company has heretofore delayed bringing suit to enjoin the manufacture or importation of such infringing lamps, solely because of the practical worthlessness of the infringing devices; and although, in each instance, they infringe some one or more of the various patents owned or controlled by this Company, they have fallen into disuse sooner than any suit could be brought to a hearing. As, however, the introduction of these infringing lamps has tended to discredit the practicability of our Company's system of regenerative gas lighting, we have instructed our Attorneys, Messrs. Geo. Harding, C. S. Whitman, and Silas W. Pettit, to give notice that legal proceedings will in future be taken against all such infringers.

THE SIEMENS-LUNGREN CO., 21st St. & Washington Av., Phila., Pa.

BARTLETT, HAYWARD & CO.

Baltimore, Md.

Munich Regenerative Furnace, System Drs. Schilling & Bunte.

Greatest durability; minimum of attention; complete distillation in 3½ hours; 10 to 13 pounds of coke to hundred-weight of coal; no clinker; no carbonic oxide in regenerative flues.

TWO AND THREE-LIFT TELESCOPIC GASHOLDERS,

With Wrought Iron Tanks, constructed above ground, of any magnitude.

Condensers, Scrubbers, Purifiers, Bench Castings, Roofs, Boilers, Etc.

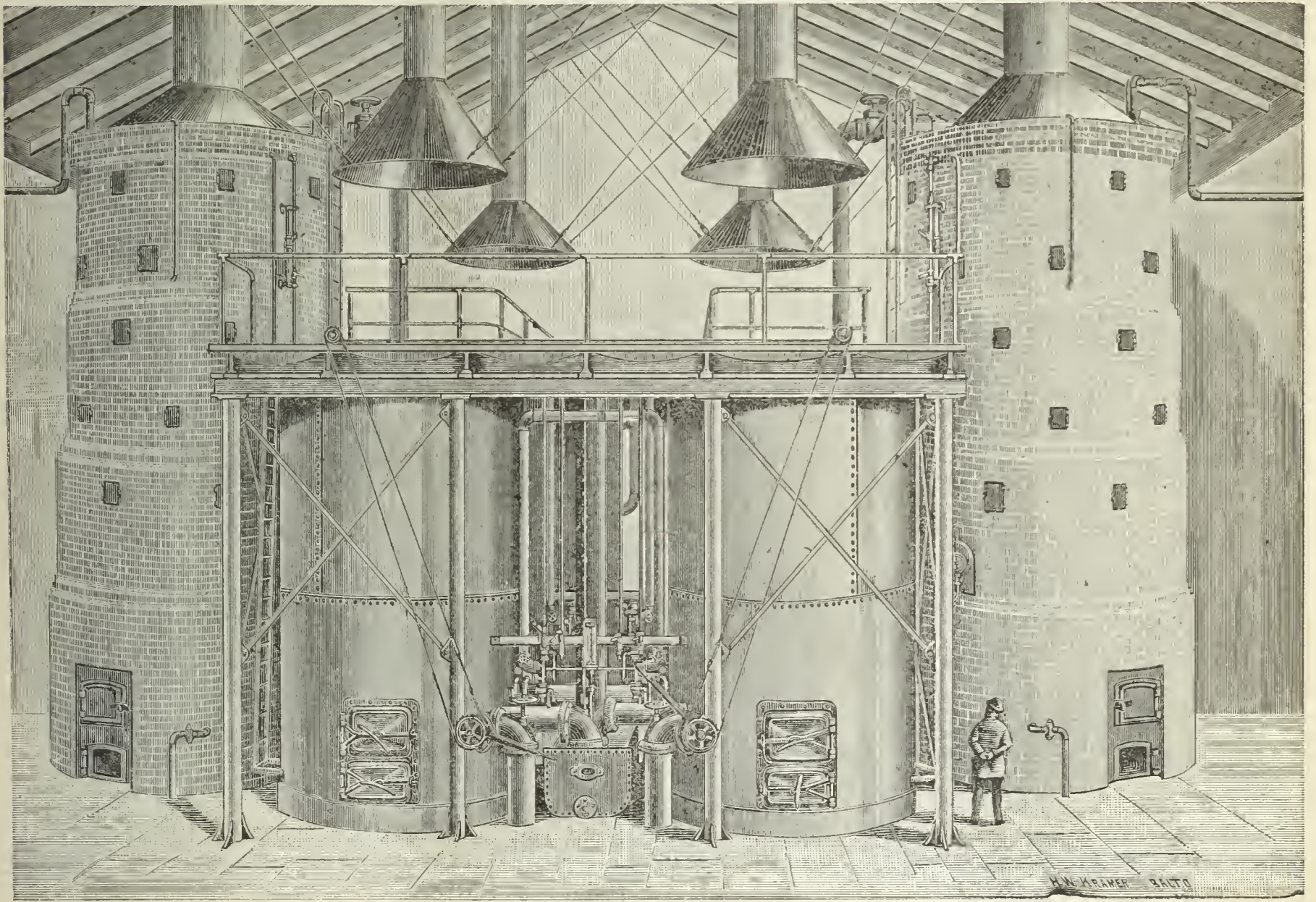

The Wilkinson Water Gas Process.

Introducing the Munich Regenerative Furnace for Coal Gas, we find on the part of many Gas Companies the desire to combine to a greater or less extent an efficient system of making high candle power Water Gas; and with a view of enabling this to be done WITHOUT EXCESSIVE CHARGES FOR PATENT RIGHTS, ETC., we have acquired, by purchase, the exclusive right to construct all the Water Gas Apparatus under the valuable "Wilkinson" Patents.

The results obtained by this Process are far better than those obtained by any other apparatus, especially where an illuminating gas of high candle power or a fuel gas of intense temperature is required.

The Process is uninterrupted, making gas of uniform quality and quantity. Its greatest advantages are maximum production with minimum material and labor, combined with great durability of apparatus.

The Process is in successful operation at the works of the N. Y. Mutual Gas Company, New York; Consolidated Gas Company, Baltimore, Md.; the Hudson County Gas Light Company, of Hoboken, N. J.; and at Rye, N. Y.

We shall be glad to give further detailed information upon application.

Sole Agents for the Celebrated Hazleton Boiler.

BARTLETT, HAYWARD & CO.

EXHAUSTERS.

EXHAUSTERS.

PROCESSES.

ROOTS' NEW GAS EXHAUSTER.

CINCINNATI, OHIO, }
 March 24, 1887. }

P. H. & F. M. Roots, Connersville, Ind.: Gentlemen—
 I have the honor to say that after the continuous and uninterrupted use of your Exhausters for a period of 15 years, it affords me pleasure to endorse them in the highest possible terms.

Very respectfully,
 A. HICKENLOOPER,
 Prest. Cincinnati Gas Co.

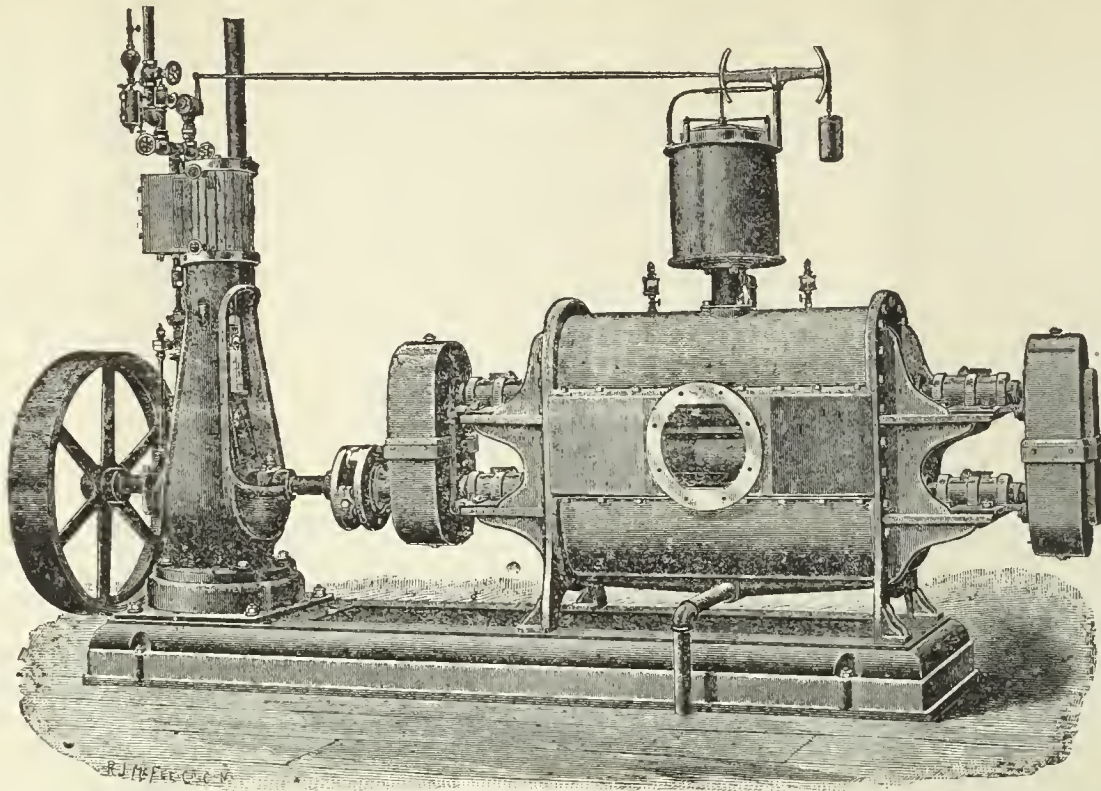

CHICAGO, ILL., }
 March 24, 1887. }

Messrs. P. H. & F. M. Roots, Connersville, Ind.:
 Dear Sirs—We have two of your No. 6 Exhausters at our works, which have been running for several months, and are giving very good satisfaction.

Yours truly,
 THEO. FORSTALL,
 Prest.

CONSTRUCTED ON ENTIRELY NEW PRINCIPLES.

THE ONLY EXHAUSTER MADE IN WHICH

The Internal Operating Parts Consist of Only Two Pieces, Each Cast Entire in One Piece.

Send for Descriptive Catalogue and Price List.

P. H. & F. M. ROOTS, Patentees and Manufacturers, **CONNERSVILLE, IND.**

S. S. TOWNSEND, Gen. Agt., 22 Cortlandt St., N. Y. COOKE & CO., Selling Agts., 22 Cortlandt St., N. Y.

DURING THE PAST YEAR, THE

NATIONAL GAS LIGHT AND FUEL CO.

218 LA SALLE ST., CHICAGO,

Have Erected Twelve Sets of Water Gas Generating Apparatus under the *Springer Cupola* System. They are as follows:

Newton Illuminating Company, Newton, Kansas.—Daily capacity, 120,000 cu. ft.

Wellington Light & Heat Co., Wellington, Kansas.—Daily capacity, 120,000 cu. ft.

Chippewa Falls, Gas Light Co., Chippewa Falls, Wis.—Daily capacity, 120,000 cu. ft.

Elkhart Gas Light & Coke Co., Elkhart, Indiana.—Daily capacity, 120,000 cu. ft.

Madison City Gas Light Company, Madison, Wis.—Daily capacity, 120,000 cu. ft.

South Bend Gas Light Co., South Bend, Indiana.—Daily capacity, 250,000 cu. ft.

Sheboygan National Gas Comp'y, Sheboygan, Wis.—Daily capacity, 120,000 cu. ft.

Salina Gas Light Company, Salina, Kansas.—Daily capacity, 120,000 cu. ft.

Rathbun Company, Deseronto, Province Ontario.—Daily capacity, 80,000 cu. ft.

Jefferson City Gas Light Co., Jefferson City, Mo.—Daily capacity, 120,000 cu. ft.

Mankato Gas Light Company, Mankato, Minnesota.—Daily capacity, 80,000 cu. ft.

Minneapolis Gas Lt. & Coke Co., Minneapolis, Minn.—Daily capacity, 1,000,000 cu. ft.

1886

1886

CONNELLY & CO., LTD.,

SOLE MANUFACTURERS OF THEIR PATENTED SPECIALTIES.

"IRON SPONGE." Saves money, saves labor, and is the most efficient purifying agent ever offered as a substitute for lime. Now used in every State in the Union, and purifying daily over twenty-five million cubic feet. Should be used in every gas works. Its own saving will pay for it many times over.

AUTOMATIC GOVERNOR. Has been on the market but two years, and in that time has been introduced more generally than any invention ever designed for use in gas works. Over one hundred of them now in use. Sensitive; reliable; perfectly automatic; reduces leakage; satisfies consumers, and gives great relief to the Manager. No gas works is complete without one of these machines.

STEAM JET EXHAUSTER. Designed particularly for small works. Combines Exhaust Tube, Steam Governor, Gas Compensator, and Bye-Pass Valves in the most compact form possible; occupies but little space; uses very little steam; operated by ordinary workmen; saves formation of carbon in retorts; increases yield 10 to 15 per cent. Specially adapted for mixing air with oil gas. No works too small to use them profitably.

Prices given on all our specialties delivered at any point in the United States. Correspondence solicited.

CONNELLY & CO., LTD., No. 177 Broadway, New York City.

WILBRAHAM GAS EXHAUSTER

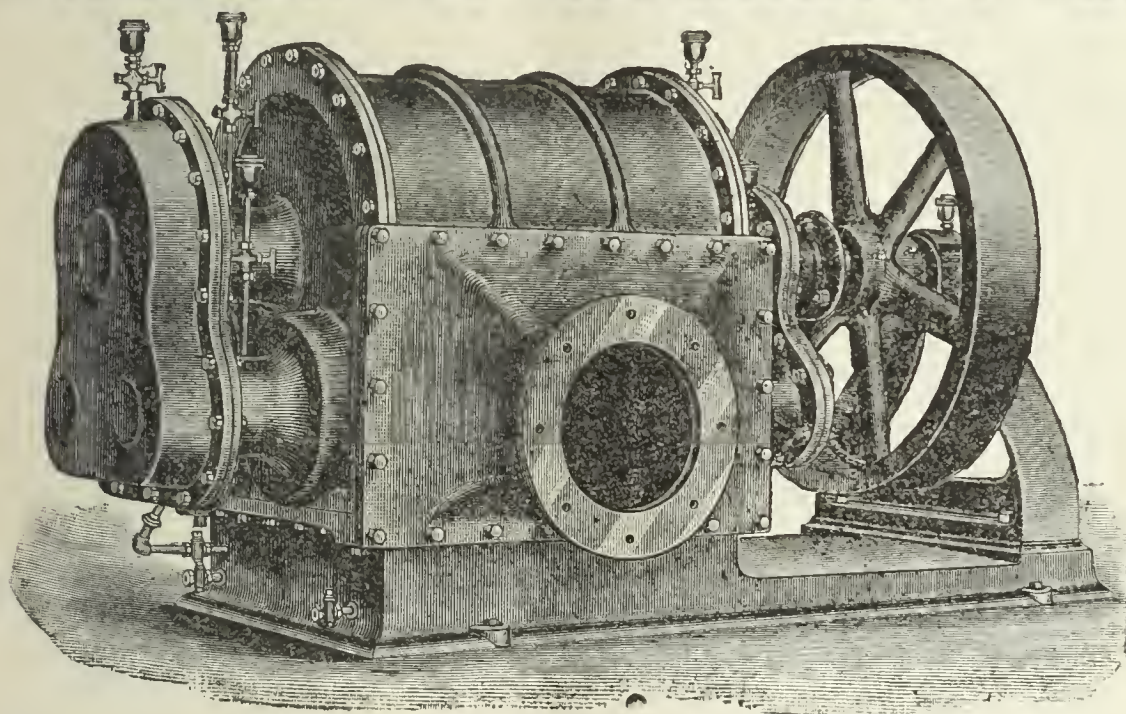

WILBRAHAM BROS.,
PHILADELPHIA, PA.

JARVIS ENGINEERING CO.,

61 Oliver St., Boston, Mass.

CONTRACTORS FOR ERECTING

COMPLETE STEAM OUTFITS FOR ELECTRIC LIGHTING STATIONS.

Steel Boilers set with Jarvis Pat. Boiler Setting,

To burn COKE SCREENINGS for Fuel.

ARMINGTON & SIMS CO. ENGINES,

Belting direct to Dynamos, without using Shafting.

SEND FOR CIRCULARS.

REFERENCES.—Charlestown Gas & Electric Light Co., Charlestown, Mass.; Schenectady Gas & Electric Light Co., Schenectady, N. Y.; Brookline Gas Co., Brookline, Mass.

Improved Patent
GAS BAG OR
BLADDER VALVE.

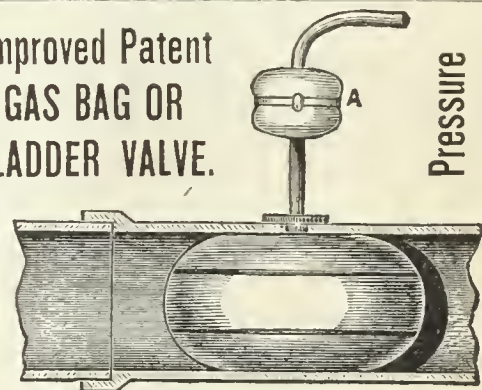

MANUFACTURED BY
PEERLESS MFG. CO., 34 Murray St., N.Y.

THE CLERK GAS ENGINE CO.,

Main Office, 1012, 1014, 1016, 1018 Filbert St., Philadelphia, Pa.

WM. W. GOODWIN, Prest.

E. STEIN, Sec.

S. LEWIS JONES, Asst. Sec.

A. J. DOTY, Supt.

The utility and convenience of the Gas Engine being no longer an open question, it only remains now for intending purchasers to select the BEST. We claim for the CLERK GAS ENGINE that it is equal to any other manufactured as regards steadiness in running, simplicity, and ease of keeping in repair, and that it gives the greatest amount of power for the least money (both in first cost and expense of running) of any engine made. In support of this claim we refer to the test of the Gas Engines made under the direction of the American Institute of New York, in December, 1885, and heretofore published in these columns. These engines are especially adapted for continuous running under heavy loads, and we can refer to Engines which have run 22 hours a day for months at a time.

Made in Sizes of 5, 10, 15, 20, and 25 Horse Power. All Engines Guaranteed for One Year.



CHAPMAN VALVE MANUFACTURING CO., LUDLOW VALVE MFG. CO.

MANUFACTURERS OF

Valves and Gates for Gas, Ammonia, Water, Etc.

Also, Gate Fire Hydrants With and Without Independent Nozzle Valve. All Work Guaranteed.

WORKS & GEN'L OFFICE:
Indian Orchard, Mass.

TREASURER'S OFFICE:
72 Kilby & 112 Milk Sts, Boston, Mass.



OFFICE AND WORKS,
938 to 954 River Street and 67 to 83 Vail Av.
TROY, N. Y.

How to Reduce Leakage to Its Minimum.

USE

HOPPER'S AUTOMATIC DIFFERENTIAL GAS GOVERNOR.

Needs No Attention. Simple, Reliable, Perfectly Automatic.
"Nearly Thirty in Use."

BYE-PASSES, DRY CENTER VALVES, PRESSURE REGISTERS. Also, GOVERNORS FOR STREET MAINS, *NOT DIFFERENTIAL*, and for EXHAUSTERS, GAS ENGINES, etc.

Our new Bye-Pass is threefold in its action—passes gas through, or bye-passes, or shuts off entirely. Correspondence solicited; information given. Send for circulars and testimonials.

T. C. HOPPER & CO., - - No. 227 Wood Street, Philadelphia, Pa.

Hydraulic Main Dip Regulators, also Check Valves, Foot Valves, Yard-wash and Fire Hydrants. Send for Circulars.

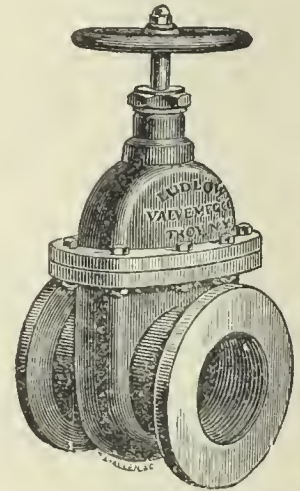

Valves.—Double and Single Gate, 1/2 in. to 48 in., outside and inside Screws. Indicator, etc., for Gas, Water, Steam, and Oil. Send for Circulars.

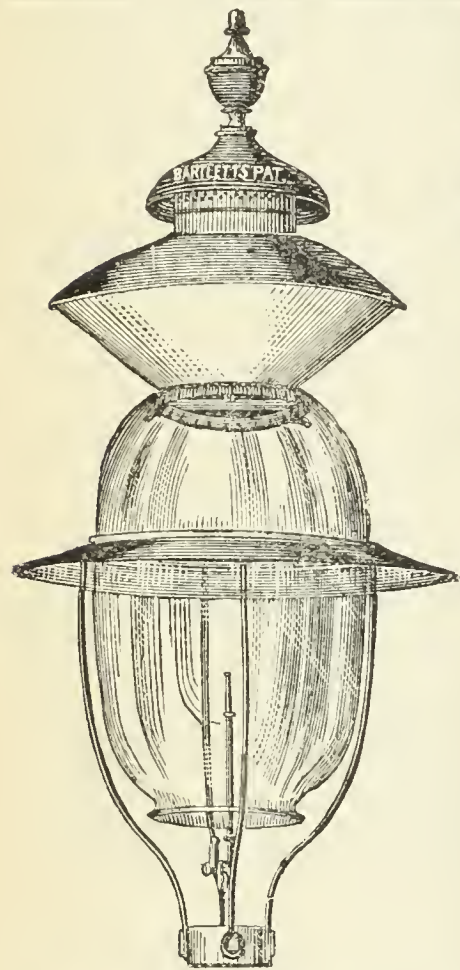

G. S. COOK, Pres. THOS. DAVENPORT (late Davenport Bros.), Sec. & Treas

BARTLETT Street Lamp Mfg. Co.

MANUFACTURERS OF

Bartlett's Patent

GLOBE LAMPS.

FOR

Streets, Parks, Railroad Stations, Public Buildings, Etc.

LAMP POSTS A SPECIALTY.

Office and Salesroom

40 & 42 College Place, N. Y. City.

Gas Companies and others intending to erect lamps and posts will do well to communicate with us.

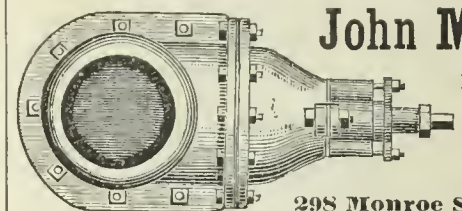

John McLean

Man'facturer of

GAS VALVES.

298 Monroe Street, N. Y.

MITCHELL, VANCE & CO.,

MANUFACTURERS OF

Chandeliers

and every description of

GAS FIXTURES.

Also manufacturers of Fine Gilt Bronzes and Marble Clocks, warranted best time-keepers. Mantel Ornaments, etc.

Salesrooms, 836 Broadway, N. Y.

Special Designs furnished for Gas Fixtures for Churches, Public Halls, Lodges, etc.

GAS AS A SOURCE OF LIGHT, HEAT, AND POWER.

By C. J. R. HUMPHREYS

A Pamphlet of twenty-nine pages, treating of the use of Gas as a source of Light, Heat, and Power.

DESIGNED FOR DISTRIBUTION BY GAS COMPANIES AMONG THEIR CUSTOMERS AND OTHERS.

Price, 10 cents each, \$5 per 100, \$50 per 1,000.

Gas Companies can have their own imprint placed on cover without extra charge. All orders to be sent to

A. M. CALLENDER & CO.,

No. 42 Pine Street, N. Y. City.

GAS STOVES.

GAS STOVES.

GAS STOVES.

THE AMERICAN METER CO.,

MANUFACTORIES,

508 to 514 West Twenty-second St., N. Y.

Arch and Twenty-second St., Phila.

Nos. 244 & 246 North Wells Street, Chicago, Ill.

AGENCIES,

No. 177 Elm Street, Cincinnati, Ohio.

Nos. 122 & 124 Sutter Street, San Francisco Cal.

No. 810 North Second Street, St. Louis, Mo.

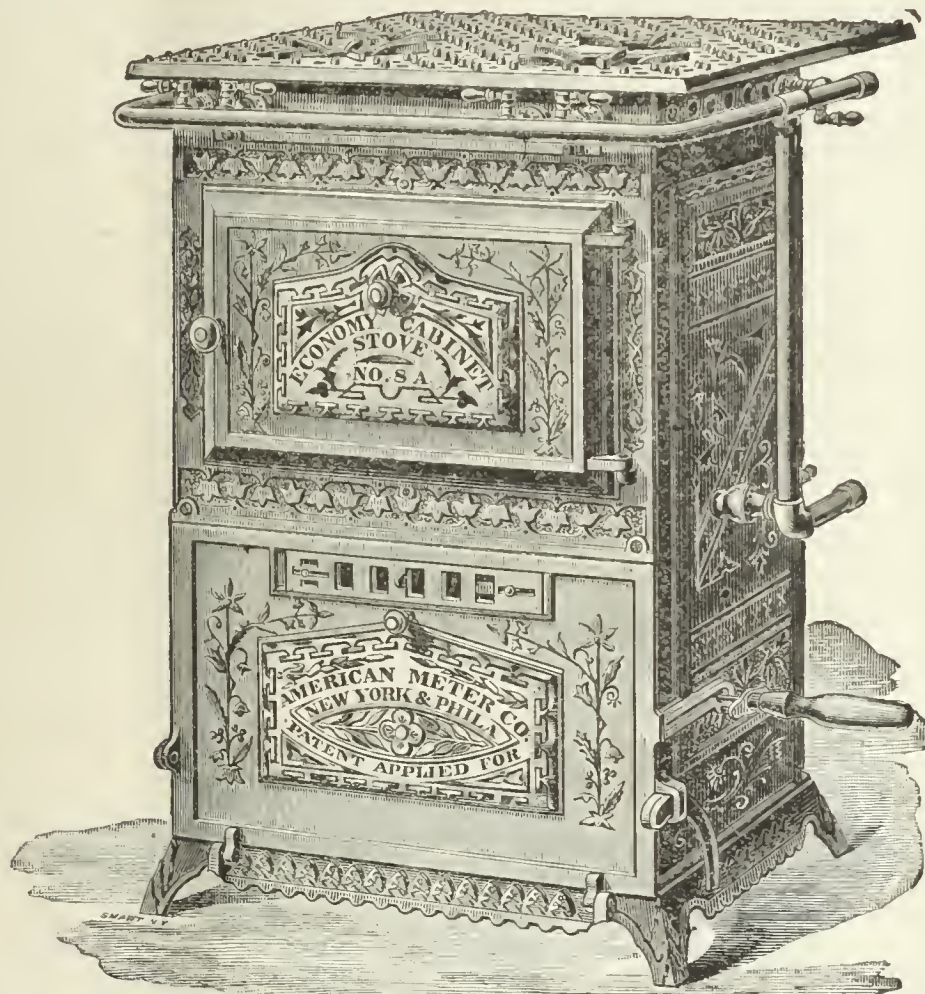

New Design Cast Iron "Economy" Cabinet Stoves.—With Open or Closed Top.

THE COMPANY MANUFACTURES

GAS STOVES FOR COOKING AND HEATING PURPOSES,

In All Sizes, for Domestic, Restaurant, and Hotel Use.

Also,

A Variety of Apparatus for Mechanical Purposes, Using Gas as Fuel.

These Stoves may be seen in operation at our Retail Store, No. 223 Sixth Avenue, N. Y. Call and examine.

SEND FOR ILLUSTRATED CATALOGUE SHOWING THE VARIOUS STYLES AND SIZES.

RETORTS AND FIRE BRICK.

J. H. CAUTIER & CO.,
CORNER OF
GREENE AND ESSEX STREETS,
JERSEY CITY, N. J.

MANUFACTURERS OF

**Clay Gas Retorts,
Gas House Tiles,
Fire Bricks, Etc. Etc.**

Ground Clay, Fire Brick and
Fire Sand in Barrels,

J. H. GAUTIER.
C. E. GREGORY.

T. B. GAUTIER.
C. E. GAUTIER.

BROOKLYN

Clay Retort & Fire Brick Works,
(EDWARD D. WHITE & CO.)

Manufacturers of Clay Retorts, Fire Brick,
Gas House and other Tile.

VAN DYKE, ELIZABETH, RICHARDS & PARTITION STS.
Office, 55 Van Dyke St., Brooklyn, N. Y.

RETORTS AND FIRE BRICK.

LAGLEDE FIRE BRICK MFG. CO.,

MANUFACTURERS OF

Fire Brick, Gas Retorts,

AND

ST. LOUIS STANDARD SEWER PIPE.

Blast Furnace and Cupola Linings, every description of Fire
Clay Material, Fire Clay Flue Linings, Chimney Tops
Dry Milled and Crude Fire Clays, etc.

OFFICE AND DEPOT

901, 903, and 905 Pine Street,
ST. LOUIS, MO.

ESTABLISHED IN 1845.

B. KREISCHER & SONS,

OFFICE FOOT OF HOUSTON ST., E. R., N. Y.

Gas Retorts,

TILES, FIRE BRICK.

AND EVERYTHING IN THE FIRE CLAY LINE.

RETORTS AND FIRE BRICK.

MANHATTAN

FIRE BRICK & ENAMELLED CLAY

RETORT WORKS.

ADAM WEBER.

CLAY GAS RETORTS

AND RETORT SETTINGS

FIRE BRICKS, TILES, ETC.,

Office and Works, 15th Street and Avenue C., N. Y.



Works,

LOCKPORT STATION, PA.

—ESTABLISHED 1864.—

JAMES GARDNER, JR.,

Successor to WILLIAM GARDNER & SON.

Office, Rooms 19 & 20, Lewis Block,
PITTSBURGH, PA., P. O. Box 373.

Fire Clay Goods for Gas Works.

CHAS. H. SPRAGUE & SON, No. 70 KILBY STREET, BOSTON, MASS., Agents for the New England States.

OFFICE, 418 to 422 East 23d St., New York.

ESTABLISHED 1856.

WORKS, PERTH AMBOY, NEW JERSEY.

HENRY MAURER & SON,
Excelsior Fire Brick & Clay Retort Works

CLAY GAS RETORTS, BENCH SETTINGS, FIRE BRICK, TILES, ETC.

CHICAGO

Retort & Fire Brick Works,

OFFICE AND FACTORY,
Clark, Forty-Fifth, and La Salle Streets,
CHICAGO, ILL.

GEORGE C. HICKS, PRES. PAUL P. AUSTIN, SEC. & TREAS.

STANDARD

Clay Retorts and Settings.

BLOCKS & TILES

Of every Shape and Size to Order.

Standard Fire Bricks.

GEROULD'S IMPROVED RETORT CEMENT.

A Cement for patching retorts, putting on mouthpieces, and
making up all bench-work joints. This Cement is mixed ready
or use. Economic and thorough in its work. Fully warranted
stick. For recommendations and price list address

C. L. GEROULD,
Manchester, N. H.

Western Agent, H. T. GEROULD, Mendota, Ill.

OAKHILL

GAS RETORT & FIRE BRICK

Works.

Proprietors,

PARKER-RUSSELL MINING & MFG. CO.

City Office, 711 Pine Street,

ST. LOUIS, MO.

Our immense establishment is now employed almost entirely in
the manufacture of

MATERIALS FOR GAS COMPANIES.

We have studied and perfected three important points. Our re-
torts are made to stand changes of temperature, the strongest
heats of the furnace, and the abrasion of feeding and emptying.
Our customers are in almost every State of the Union, to all of
whom we refer.

THOS. SMITH, Prest. AUGUST LAMBLA, Vice-Prest. & Sup

BALTIMORE

RETORT & FIRE BRICK CO.

MANUFACTORY AT

LOCUST POINT, BALTIMORE, MD.

Connection with the City by Telephone.

Clay Retorts, Blocks & Tiles,

FIRE BRICK, FIRE CLAY,

AND FIRE CEMENT.

Red and Buff Ornamental Tiles and Chim-
ney Tops. Drain and Sewer Pipe (from
2 to 30 inches). Baker Oven Tiles
12 x 12 x 2 and 10 x 10 x 2.

WALDO BROS., 88 WATER ST., BOSTON, MASS

Sole Agents the New England States.

EVENS & HOWARD,
916 Market St., St. Louis. Mo.
Works, Howard Station, Mo. Pacific R.R.

Fire Brick, Gas Retorts

AND
RETORT SETTINGS.

Sewer Pipe, 3 to 24 in. diameter.
Glass Pot Clay, Ground Fire Clay, in barrels and in bulk. All kinds of Fire Clay Goods.

Cincinnati Gas Retort & Fire Brick Works.
—ESTABLISHED 1872.—

CHAS. TAYLOR,

MANUFACTURER OF

Gas Retorts, Fire Brick, and Tile.

Blast Furnace Linings, Cupola Blocks, Boiler Tiles, Grate Settings, and Stove Linings. Fire Cement, Fire Clay, Fire Sand, and all other Fire Clay Goods.

Branch Works, New Cumberland, W. Va.
GENERAL OFFICE AND WORKS,
Burns St., Cincinnati, Ohio.

EMIL LENZ,

2 & 4 Stone St., N. Y. City.

GLAY GAS RETORTS

(ENAMELED.)

Fire Brick, Blocks & Tiles.

FIRE CEMENT, RETORT ENAMEL, RETORT CEMENT, ETC., ETC.

Regenerative and Half-Regenerative Benches.
PORTLAND CEMENT.

Correspondence Respectfully Solicited.

Bouton Foundry Co.,

FOUNDERS AND MACHINISTS,

CHICAGO, ILL.

Gas Works Apparatus,

PURIFIERS, CONDENSERS,

Bench Work,

SPECIALS, LAMP POSTS,

SCRUBBERS,

Iron Roofs and Floors.

Plans and Estimates furnished for new works or extensions of old works.

PATENTS.

FRANKLIN H. HOUGH,

Solicitor of American & Foreign Patents

925 F. ST., WASHINGTON, D. C.

(NEAR U. S. PATENT OFFICE.)

Personal attention given to the preparation and prosecution of applications for Letters Patent. All business before the U. S. Patent Office attended to for moderate fees. No Agency in the United States possesses superior facilities for obtaining Patents, or for ascertaining the patentability of inventions. Copies of patents furnished for 25 cents each. Correspondence solicited.



STEPHEN A. MORSE, President.
GODFREY REBMANN, Vice-Pros.

M. B. DYOTT,
Superintendent.

EDWIN F. MORSE, Secretary.
CARLTON M. WILLIAMS, Treas.

STANDARD GAS LAMP CO.,

Office, 411 Cherry St. Factory, 1101, 1103 & 1105 Frankford Av.

Philadelphia, Pa.

It is to the interest of Gas Companies and Cities to use Dyott's Patent Champion Lamps, which give double the light with the same consumption of gas, and will save 50 per cent. over others in cost of keeping in repair. Gas Companies and others intending to erect Lamps of any description will do well to communicate with us. Special Drawings furnished and Estimates given on application upon Architects', Engineers' or our Draughtsmen's Plans.

Our Patent System of Instantaneously Lighting Gas (without electricity) for R. R. Depots is unequalled. Our High Candle Power Burner is superior to the Electric Light or any other High Candle Burner. We manufacture every description of Ornamental Lamps.

KLOENNE & BREDEL

IMPROVED REGENERATIVE FURNACES.

Self-Sealing Mouthpieces & Bridge-Pipes, Retort Houses,

WASHER-SCRUBBERS,

Gasholders, and Complete Gas Works.

Refers, by permission, to Mr. Eugene Vanderpool, of Newark, N. J.; Mr. E. G. Cowdery, of Milwaukee, Wis.; and Mr. Theo. Forstall, of Chicago, Ill. For further information apply to

FRED. BREDEL, 332 East 17th St., N. Y. City.

Water & Gas Pipe.

RUSTLESS

Send for New Catalogue.

RUSTLESS

The **WELLS RUSTLESS IRON COMPANY,**
Nos. 7 and 9 Cliff Street, New York City.

GASHOLDER TANK CONSTRUCTION, ETC.

Gas Companies and others about to erect Gasholders will find it profitable to consult W. C. WHYTE, who for over thirty years has made a specialty of

Holder Tank Excavation and Mason Work.

Fifty tanks now in operation show the sort of work done. Address

W. C. WHYTE, No. 15 Cortlandt St., N. Y. City.

MILLS' REVERSIBLE LIME TRAY,

AND

WOODWORK

Of Every Description

NEEDED BY GAS WORKS.

SEND FOR CIRCULAR AND PRICE LIST TO

GEORGE A. MILLS,

Canton Av. & President St., Baltimore, Md.

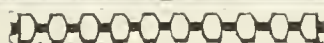
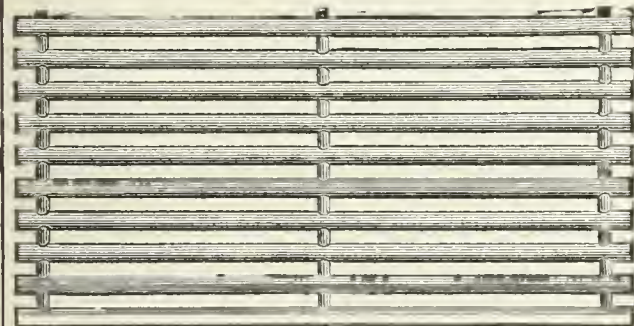

Ferric Oxide for Gas Purification.

Ferric Oxide, as ground, screened, and prepared by me for purifying purposes, has now been in use for several years by many of the gas works throughout the country, including Detroit, Chicago, Milwaukee, East Saginaw, Burlington (Iowa), Ann Arbor, etc. It has proved, as I believe, the Most Effective and Economical Agent now in use. I am prepared to furnish the Oxide by the 100 lbs. or in car load lots, and will be pleased to give price f.o.b. cars at Ann Arbor or at place of destination. Address

S. H. DOUGLAS, Prest. Ann Arbor (Mich.) Gas Light Co,

GAS AND WATER PIPES.

GAS AND WATER PIPES.

ENGINEERS.

SAM'L R. SHIPLEY, Pres.
HENRY B. CHEW, Treas.

JAS. P. MICHELLON, Sec.
WM. SEXTON, Supt.

P. D. WANNER, Chairman. A. H. MELLERT, Sec. & Treas.

GLOUCESTER IRON WORKS
GLOUCESTER CITY, N. J.

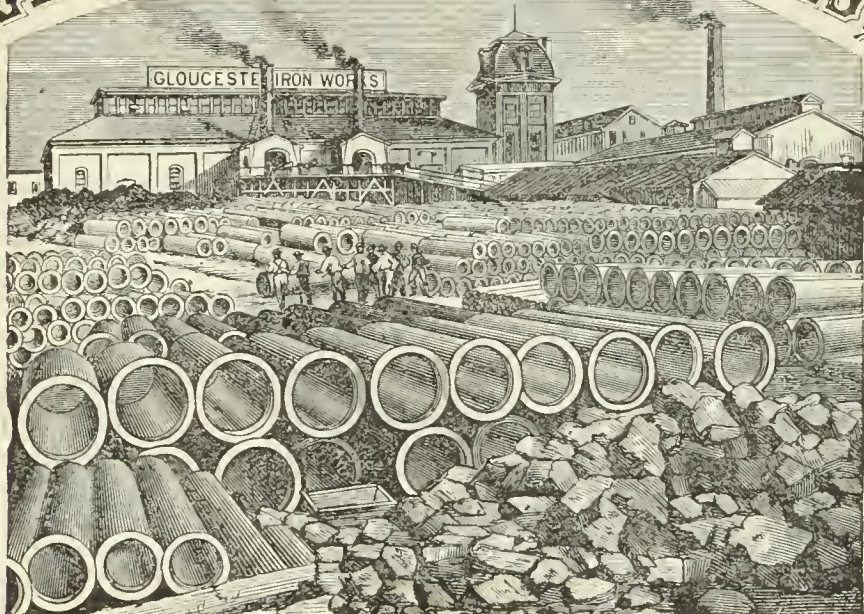

Cast Iron Gas & Water Pipes, Stop Valves, Fire Hydrants, Gasholders. &c.

Office No. 6 North Seventh Street, Philadelphia.

MELLERT FOUNDRY & MACHINE CO., Ltd.

Reading, Pa.

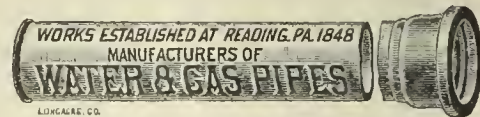

Specials—Flange Pipe, Valves and Hydrants, Lamp Posts, Retorts, etc.

General Foundry and Machine Work.

JOHN FOX, Selling Agent. 160 Broadway, N.Y.

THE OHIO PIPE COMPANY,

MANUFACTURERS OF

Cast Iron Gas & Water Pipe,

BRANCH AND SPECIAL CASTINGS.

Gas-House Bench Castings, Hydraulics, Lamp Posts, Flange Pipe and Specials, Architectural Castings, Building Columns, Joists, Cellar Grates, Sash Weights, etc.

GENERAL FOUNDERS AND MACHINISTS.

Columbus, Ohio.

M. J. DRUMMOND,



SPECIAL CASTINGS AND LAMP POSTS.

Equitable Building, 120 Broadway, N. Y.

JOS. R. THOMAS, C.E.,

May be Consulted on all Matters Relating to Gas Works and Gas Manufacture.

ADDRESS THIS OFFICE.

WM. MOONEY

(Successor to WM. FARMER)

27 Pearl Street, N. Y. City.

(One door from Whitehall Street.)

CONTRACTOR FOR THE ERECTION OF GAS WORKS, OR APPARATUS OF ANY CAPACITY. AGENT FOR

WM. FARMER'S PATENTS.

Plans and Specifications Furnished.

WM. HENRY WHITE,

CONSULTING AND CONSTRUCTING

Gas Engineer & Contractor

Estimates, Plans, and Specifications furnished for new works or extensions of existing works.

No. 32 Pine Street, New York City.

Correspondence solicited.

WM. GARDNER,

Gas Engineer,

Lewis Block, Room 20, Pittsburgh, Pa.

Those who intend to make alterations in existing gas plants, or who contemplate the erection of new works, will find it to their interest to open correspondence with the above. Plans made and estimates furnished.

MATTHEW ADDY, President.

W. L. DAVIS, Selling Agent.

GEO. P. WILSHIRE, Sec. & Treas.

Cincinnati and Newport Iron and Pipe Company,

NEWPORT, KY.

Lamp Posts

AND

BENCH CASTINGS

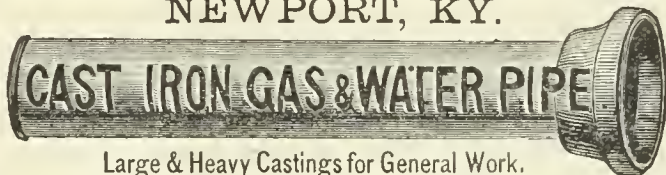

Branch

AND

SPECIAL CASTINGS

A Specialty.

Large & Heavy Castings for General Work.

FOR GAS & WATER CO'S.

Manufacture Pipe from 2 to 48 inches. All work guaranteed first quality.

Pancoast & Rogers.

WROUGHT IRON PIPE,

VALVES AND GATES,

Cast Iron Gas & Water Pipe.

28 Platt and 15 Gold St., New York.

GEO. SHEPARD PAGE,

No. 69 Wall Street, N. Y. City.

REPRESENTING

THE BOWER GAS LAMP.

C. & W. Walker's Carbonic Acid & Tar Extracting Washer

B. DONKIN & CO'S PAT. IMP. GAS VALVE.

Young & Beilby's Patents. Henry Aitkin's Patents.

R. P. SPICE, London, Eng. HENRY SIMON, Manchester, Eng.

The Management of Small Gas Works.

By C. J. R. HUMPHREYS. Price, \$1.

A. M. CALLENDER & CO., 42 Pine St., N. Y.

GAS LAMPS.

SCRUBBERS AND CONDENSERS.

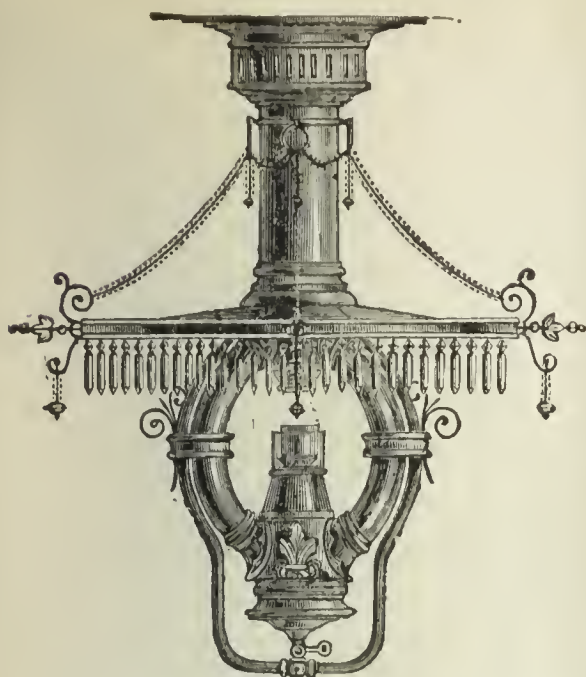

SIEMENS LAMP.

The Siemens and Lungren REGENERATIVE GAS LAMPS.

A System of Burning Gas whereby its Illuminating Power is Increased from 300 to 400 per ct. without the Expense, Trouble and Annoyance resulting from the use of Hydrocarbon Enriching Material.

The Siemens-Lungren Company received the only Silver Medal or Highest Award for Gas Burners at the "Novelties" Exhibition of the Franklin Institute, held at Phila., Oct., '85.

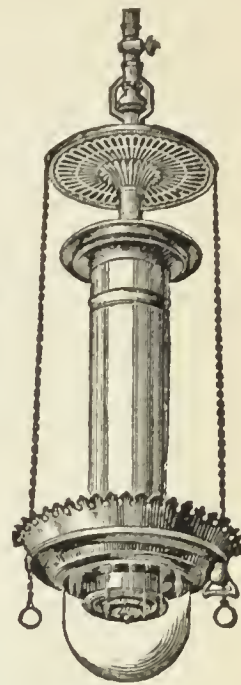

LUNGREN LAMP

THIRTEEN CANDLE POWER PER CUBIC FOOT OF GAS!

This result is obtained

SIMPLY BY THE SCIENTIFIC APPLICATION OF THE REGENERATIVE PRINCIPLE.

Consequently this largely increased illumination is always maintained without further cost and frequent attention.

THE SIEMENS-LUNCREN COMPANY,

N. E. Cor. 21st. St. and Washington Av., Phila., Pa.

THE PATENT "STANDARD" WASHER-SCRUBBER

(KIRKHAM, HULETT & CHANDLER PATENT.)

Has been adopted by gas companies in all parts of the world. Between 300 and 400 companies, with the enormous daily output of over 300,000,000 cubic feet, are now using it. "Standard" Washer-Scrubbers have been erected for the following gas light companies since Jan. 1, 1886:

WALLASEY, ENGLAND.....	750,000 cubic feet.	RICHMOND, SURREY, ENGLAND.....	1,500,000 cubic feet.
NEWARK, ENGLAND.....	350,000 "	BRIDGEPORT, U. S.....	500,000 "
BUFFALO, U. S. (MUTUAL).....	500,000 "	TORONTO, CANADA.....	1,000,000 "
BERLIN, GERMANY.....	1,250,000 "	HARTFORD, U. S.....	1,000,000 "
SO. BRISBANE, AUSTRALIA.....	300,000 "	DETROIT, U. S.....	750,000 "
LEEDS, ENGLAND.....	2,000,000 "	SINGAPORE, CEYLON.....	300,000 "
FURTH, GERMANY.....	400,000 "	BRUNSWICK, GERMANY.....	300,000 "
FREIBURG, GERMANY.....	200,000 "	LILLE, FRANCE.....	750,000 "
NINE ELMS, LONDON.....	3,000,000 "	CADIZ, SPAIN.....	300,000 "
MELBOURNE, AUSTRALIA (2).....	3,000,000 "	READING, ENGLAND.....	2,000,000 "
GLUCKAUF COKE WORKS, GERMANY.	200,000 "	LINCOLN, U. S.....	250,000 "
BOURNEMOUTH, ENGLAND.....	1,000,000 "	ST. LOUIS, U. S. (LACLEDE).....	1,000,000 "
		BROOKLYN, U. S.....	2,000,000 "
		BROOKLYN, U. S. (NASSAU).....	1,000,000 "
		DENVER, U. S.....	1,000,000 "

That this apparatus is really the *standard* is indicated by the following names of important houses who represent this invention in the different countries of the world:

FRANCE & BELGIUM, Mons. J. A. Berly, 31 Rue Boinod, Paris. HOLLAND & DUTCH COLONIES, Mess. W. Hoven & Zoon, Rotterdam.

GERMANY and AUSTRO-HUNGARY, Berlin-Anhaltische-Actiengesellschaft, Berlin, Moabit, and Dessau.

RUSSIA, Mr. F. Bley, Galernaya, 44, St. Petersburg. SPAIN, Mess. Nicolas, Chamon, Foiret & Cie., 29 Rue Claude-Vellefaux, Paris.

ITALY & MALTA, Sig. E. Canziani, 26 & 28 Portici, Vittorio Emmanuele, Genoa. Sig. Fratelli Scheuer, Via Chiaja, 124, Naples

NEW SOUTH WALES, Messrs. W. Coward & Sons, 143 Queen Victoria St., London.

NEW ZEALAND and VICTORIA, Messrs. G. D. Jennings & Co., 28 Gracechurch St., London.

Companies in the U. S. adopting this apparatus can now be assured of a market for the Ammoniacal Liquor at a remunerative price. Correspondence for purchase of "Standards" and Ammoniacal Liquor is solicited by the

GEO. SHEPARD PAGE, 69 WALL STREET, NEW YORK.

GAS WORKS APPARATUS AND CONSTRUCTION.

GAS WORKS APPARATUS AND CONSTRUCTION.

WORKS: { MILLVILLE, N. J.
FLORENCE, " "
CAMDEN, " "

R. D. WOOD & CO.,

OFFICES: { 400 CHESTNUT ST.,
PHILADELPHIA.

CAST-IRON PIPE 1½ to 72 Inches in Diameter.

Water Machinery and Gas Apparatus.

HEAVY CASTINGS.

HOLDERS,

LAMP POSTS,

VALVES,

PURIFIERS,

CONDENSERS,

BENCH WORK;

METER CASES.

FLOORS AND ROOFS,

FLANGED PIPE,

FIRE HYDRANTS,

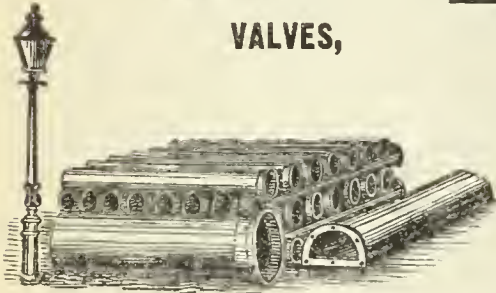

Estimates and Specifications for
NEW WORKS or **EXTENSIONS**
or **ALTERATIONS** of **OLD ONES.**

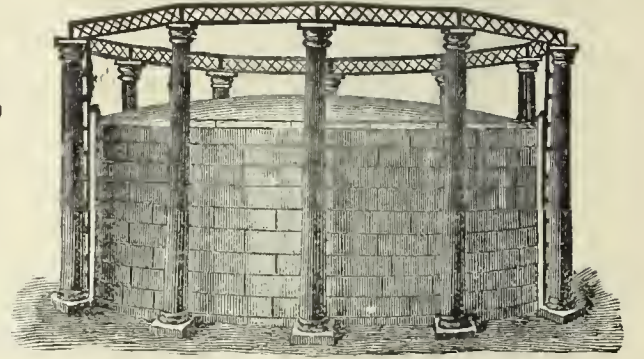

SOUTHWARK FOUNDRY AND MACHINE COMPANY,

Successors to MERRICK & SONS,

GAS APPARATUS,

Holdings, Purifiers, Washers, Etc., Etc. Boiler and Tank Work. Steam Engines.
Hydraulic Machinery. Bessemer Plants, Etc.

Washington Ave. and Fifth Street, Philadelphia, Pa.

MORRIS, TASKER & CO.,

Limited,

Builders of Gas Works,

PHILADELPHIA PA.

F. J. DAVIS & J. R. FARNUM,

TRUSTEES AND AGENTS FOR THE

SINUOUS FRICTION CONDENSER.

We desire to draw the attention of the gas community to the merits of the **SINUOUS FRICTION CONDENSER**. Companies intending to introduce new condensers into their works will do well to confer with us and examine plans and estimates before contracting for any other pattern. The **FRICTION CONDENSER** is now in use at the gas works located in the following places:

Portland, Me.	Brookline, Mass.	Pawtucket, R. I.	Frederickton, N. B.
Newport, R. I.	Chelsea, Mass.	Jamaica Plain, Mass.	St. John, N. B.
Gloucester, Mass.	Woburn, Mass.	Attleboro, Mass.	Paterson, N. J.
Newton & Water- town, Mass.	Peoria, Ill.	Calais, Me.	Dover, N. H.
	Clinton, Mass.	Fall River, Mass.	Waltham, Mass.
	Nassau Works, Brooklyn, N. Y.		

DAVIS & FARNUM MFG. CO.

MANUFACTURERS OF

Gas and Water Pipes,

AND

GAS AND WATER MACHINERY

OF THE MOST APPROVED PATTERN.

Also, Gasholders and Iron Roofing.

Orders from Gas and Water Companies promptly attended to.

WALTHAM, MASS.

Boston Office, Room 55, Mason Building, 70 Kilby Street.

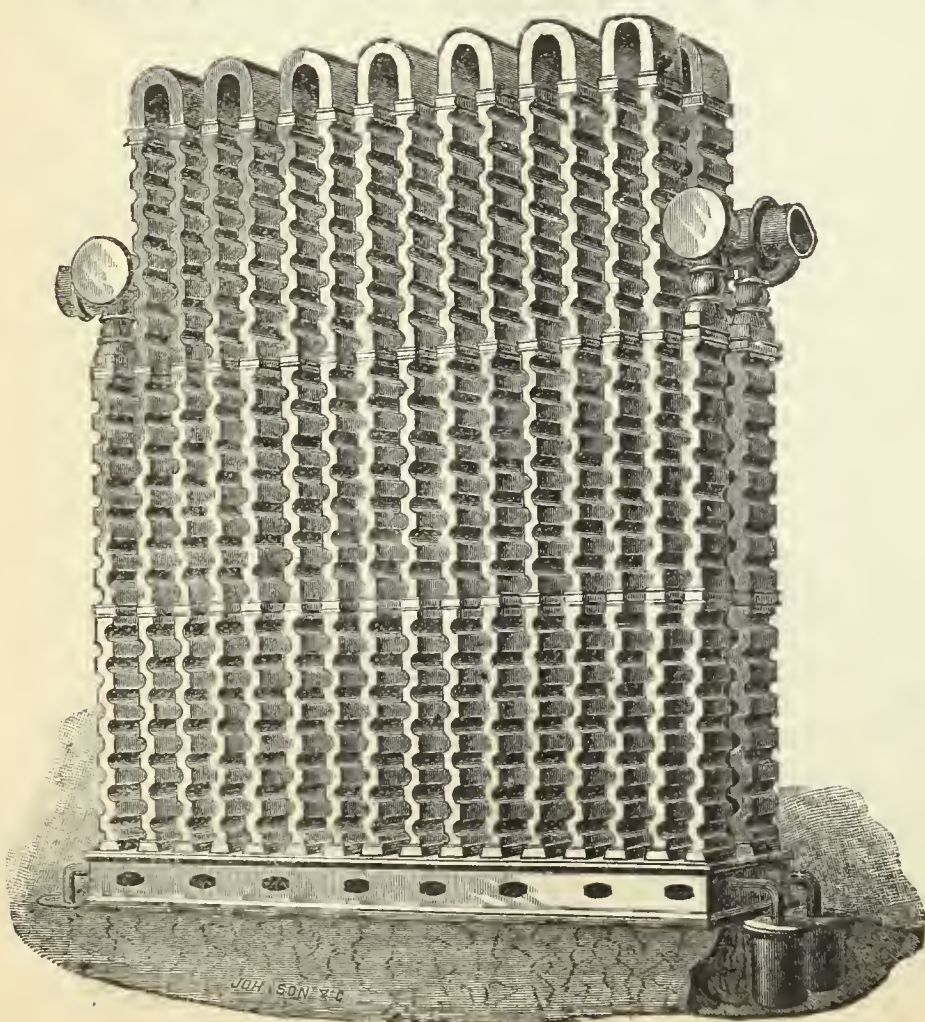

GAS WORKS APPARATUS AND CONSTRUCTION.

GAS WORKS APPARATUS AND CONSTRUCTION.

JAMES R. FLOYD,

(SUCCESSOR TO HERRING & FLOYD)

Oregon Iron Works,

531 to 543 West 20th St., N. Y.

Practical Builders of Gas Works,

MANUFACTURERS OF

ALL KINDS OF CASTINGS
AND

APPARATUS FOR GAS-WORKS.

BENCH CASTINGS

from benches of one to six Retorts each.

**WASHERS: MULTITUBULAR AND
AIR CONDENSERS; CONDENSERS;
SCRUBBERS**

(wet and dry), and

EXHAUSTERS

for relieving Retorts from pressure.

BENDS and BRANCHES

all sizes and description.

FLOYD'S PATENT

MALLEABLE RETORT LID.

PATENT

SELF-SEALING RETORT LIDS.

FARMER'S

PATENT BYE-PASS DIP-PIPE.

SABBATON'S PATENT

FURNACE DOOR AND FRAME.

BUTLER'S

COKE SCREENING SHOVELS.

GAS GOVERNORS,

and everything connected with well regulated Gas Works at low price, and in complete order.

SELLER'S CEMENT

for stopping leaks in Retorts.

N. B.—**STOP VALVES** from three to thirty inches—at very low prices.

Plans, Specifications, and Estimates furnished.

GAS vs. ELECTRIC LIGHT.

We would invite attention to the able and exhaustive argument of General A. Hickenlooper, President of the Cincinnati Gas Light and Coke Company, contained in a handsome pamphlet of 96 pages, entitled

"EDISON'S INCANDESCENT ELECTRIC LIGHTS FOR STREET ILLUMINATION. REPORT OF AN ARGUMENT DELIVERED BY A. HICKENLOOPER BEFORE THE COMMITTEE ON LIGHT, MUNICIPAL COUNCIL, CITY OF CINCINNATI, JULY 22, 1886."

This is a subject of special interest to all Gas Light Companies.

Prices.

25 copies..... \$7.50 100 copies..... \$22.50
50 copies..... 12.50 250 copies..... 50.00

A sample copy will be sent by mail on receipt of 50 cts.

A. M. CALLENDER, & CO., 42 PINE ST., N. Y. CITY.

THE CONTINENTAL IRON WORKS.

THOS. F. ROWLAND, Presl. WARREN E. HILL and CHAS. H. CORBETT, V.-Presl. THOS. F. ROWLAND, JR., Sec. & Treas.

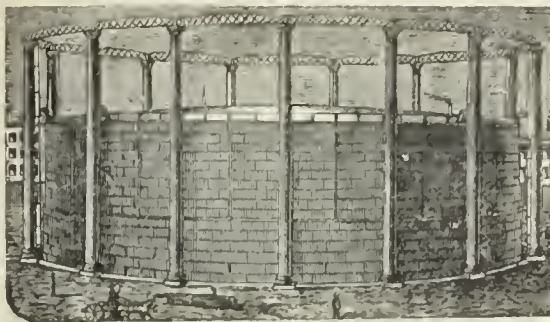

GAS HOLDERS OF ANY MAGNITUDE.

P. O. Station G., BROOKLYN, N. Y.

ENGINEERS AND MANUFACTURERS OF

Gas Holders

CONDENSERS, SCRUBBERS, VALVES,

PURIFIERS, SELF-SEALING RETORT LIDS,

Hydraulic Mains,

And all other articles connected with the manufacture and distribution of Gas.

H. RANSIAW, Presl. & Mangr. WM. STACEY, Vice-Presl. T. H. BIRCH, Asst. Mangr. R. J. TARVIN, Sec. & Treas.

STACEY MFG. CO.,

MANUFACTURERS OF

Single and Telescopic Gasholders,

IRON ROOFS, BRIDGES, LAMP POSTS,

Water and Oil Tanks, Coal Elevator Cars,

COKE CRUSHERS, BENCH CASTINGS,

And all kinds of Wrought and Cast Iron Work used in the erection of Coal and Oil Gas Works. Rolling Mill Machinery and Heavy Castings a Specialty.

Foundry:

33, 35, 37 & 39 Mill Street.

Wrought Iron Works:

16, 18, 20, 22, 24 & 26 Ramsey Street:

Cincinnati, Ohio.

1842. **DEILY & FOWLER,** 1887.

Laurel Iron Works.

Address, No. 39 Laurel Street, Philadelphia, Pa.

MANUFACTURERS OF

GASHOLDERS.

Single or Telescopic, with Cast or Wrought Iron Guide Frames.

HOLDERS BUILT SINCE 1881:

- | | | | | |
|-----------------------|----------------------------|---------------------------|----------------------------|----------------------------|
| Scranton, Pa. (3d) | Hollidaysburg, Pa. | Jackson, Mich. | Montgomery, Ala. | New Castle, Pa. |
| West Point, N. Y. | Galveston, Texas (2d.) | Kalamazoo, Mich. (3d.) | Newport, R. I. | Long Island City, N. Y. |
| Fitchburgh, Mass. | Marlboro, Mass. | Glen Island, N. Y. | Portland, Oregon. | Macon, Ga. |
| New London, Conn. | Denver, Col. | Warren, Ohio. | Allegheny, Pa. (2d.) | York, Pa. |
| Derby, Conn. | Chicago, Ill. (West Side). | Bath, N. Y. | Atlanta, Ga. (2d.) | Chester, Pa. |
| Bridgeport, Conn. | Pittsburgh, Pa. (S. Side) | Lynn, Mass. | N.Y. City (Central Gas Co) | Hazleton, Pa. (2d.) |
| Allegheny, Pa. (1st.) | Pawtucket, R. I. | New Bedford, Mass. | Lynchburg, Va. (2d.) | Novelties Exhib., Phila |
| St. Hyacinth, Can. | Brookline, Mass. | Waterbury, Conn. | Saylesville, R. I. | Staten Island, N. Y. |
| Norwalk, O. | Sherbrooke, Can. | Deseronto, Can. | Rondout, N. Y. | Saugerties, N. Y. |
| Brattleboro, V | Burlington, N. J. (2d.) | Hoosic Falls, N. Y. (2d.) | Atlantic City, N. J. | Clinton, Mass. (Lan. Mills |
| Waltham, Mass. (2d.) | Bridgeton, N. J | Bethlenem, Pa. | Augusta, Ga. | Chattanooga, Tenn. |
| West Chester, Pa.; | Bay City, Mich. | Atlanta, Ga. (1st.) | Waltham, Mass. (2.) | Galveston, Texas. (3d.) |
| Baltimore, Md. | Erie, Pa. | Savannah, Ga. | Mahanoy City, Pa. | Omaha, Neb. |

SMITH & SAYRE MFG. COMPANY,

G. PORTER, Presl.

245 Broadway, N. Y.

CHAS. W. ISBELL, Sec'y.

Machinery & Apparatus for Gas Works

Drawings, Plans, and Estimates Furnished for the Improvement, Extension, or Alteration of Gas Works, or for the Construction of New Works.

Mackenzie's Patent Rotary and Steam Jet Gas Exhausters, Governors, Compensators, Condensers, Washers, Scrubbers. Isbell's Patent Automatic Street Pressure Governor, Gas and Water Valves, Hydraulic Main Dip Regulator, Bench Castings, etc. Purifying Boxes and "Standard" Scrubbers. Isbell's Patent Self-Sealing Retort Doors.

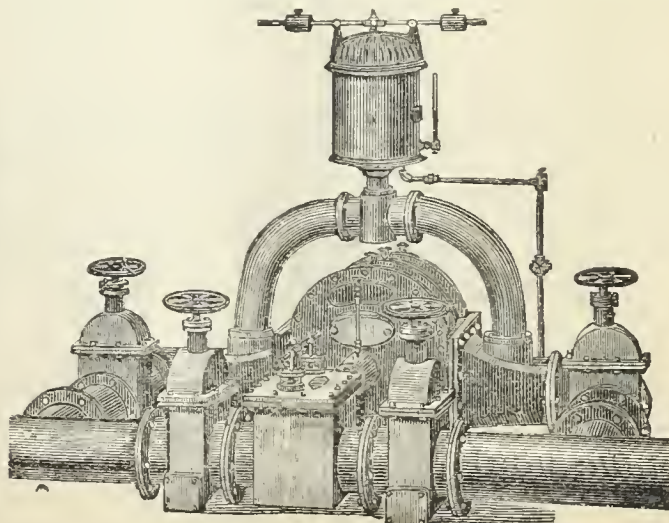

GAS COALS.

CANNEL COALS.

GAS ENRICHERS.

JAMES D. PERKINS,

PERKINS & CO.,

F. SEAVERNS.

General Sales Agents for

The Youghiogheny River Coal Company's

OCEAN MINE YOUGHIOGHENY GAS COAL.

The Coal from the Ocean Mine (recently operated by *Messrs. W. L. Scott & Co.*, of Erie, Pa.,) is now used by all the leading Gas Companies in the United States from Maine to Texas, and is recognized as *the only reliable Youghiogheny Gas Coal.* (See Map on p. 87 of this Journal, Feb. 16, '85.)

P. O. Box 3695,
New York.

PERKINS & CO., 228 and 229 N. Y. Produce Exchange.

BEAVER STREET
ENTRANCE.

BRECKENRIDGE CANNEL, OF KENTUCKY.

This Colliery was re-opened in June, 1886, since which date the Cannel has been delivered to over sixty of the leading Gas Companies in this country and in Europe. As an enricher ONE TON of this Cannel will do the work of TWO TONS of any other available Cannel, and is more economical than Naptha or Oil of any character. It can be delivered in parcels of one car load or more to any point in the United States or Canada.

(See AMERICAN GAS LIGHT JOURNAL, June 16, '86, pp. 346-7.)

P. O. Box 3695,
New York.

PERKINS & CO., 228 and 229 N. Y. Produce Exchange

BEAVER STREET
ENTRANCE.

JAMES & WILLIAM WOOD, Gas and Cannel Coal Contractors,

No. 40 St. Enoch Sq., Glasgow. No. 2 Talbot Court, London.

Proprietors of the BATHVILLE COLLIERIES (which produce the celebrated BOGHEAD CANNEL), Shields, Shieldmuir, Drumpeller, and other Collieries. This Firm offer

STANDARD CANNELS,

Unequaled as Gas Enrichers.

Analyses, prices, and all further information furnished on application to

Agency for U. S., Room 93, Nos. 2 & 4 Stone St., N.Y. City.

The Standard Oil Company,

REFINERS OF

NAPTHA AND GASOLINES.

ALSO MANUFACTURERS OF

A Special Grade of Naptha for Gas Companies

FOR ENRICHING COAL GAS.

Correspondence solicited.

No. 43 Euclid Avenue, Cleveland, Ohio.

To Gas Companies.

We make to order CAP BURNERS to burn any amount under a stated pressure. Send for samples.

Also, SERVICE CLEANERS, DRIP PUMPS, and STREET MAIN PROVING APPARATUS.

C. A. GEFRORER,

248 N. 8th Street, Phila., Pa.

GOODWIN'S DIRECTORY

OF THE GAS LIGHT COMPANIES of the UNITED STATES & CANADA.

Price, \$10.00.

Orders may be sent to

A. M. CALLENDER & CO., No. 42 Pine Street, N. Y. City.

COKE CRUSHERS.

GAS COALS.

GAS COALS.

Newburgh Orrel Coal and Coke Co.

MINERS AND SHIPPERS OF

Mountain Brook Steam and Smithing Coals,

**NEWBURGH, PALATINE,
AURORA & TYRCONNELL
GAS COALS.**

Foundry & Crushed Coke Shipped Direct from Ovens
Mines Situated at
Newburgh, Flemington & Fairmont, W.Va.

HOME OFFICE,

33 S. Gay St., Baltimore.

CHAS. MACKALL, Gen. Mangr.

CHAS. W. HAYS, Agent in New York,

Room 147, WASHINGTON BUILDING, No. 1 Broadway.

Shipping wharves at Locust Point, Baltimore.

THE DESPARD COAL COMPANY

OFFER THEIR SUPERIOR

DESPARD COAL

To Gas Light Companies and Manufacturers of Fire Clay Goods
Throughout the Country.

ROUSSEL & HICKS, } AGENTS. { BANGS & HORTON,
71 Broadway, N. Y. } 16 Kilby St., Boston.

Mines in Harrison Co., West Va. Wharves, Locust Point, Balt.

Company's Office, 15 German St., Baltimore, Md.

Among the consumers of Despard Coal we name: Manhattan
Gas Light Co., N. Y.; Metropolitan Gas Light Co., N. Y.; Jersey
City, (N. J.) Gas Light Co.; Washington (D. C.) Gas Light Co.;
Portland (Maine) Gas Light Co. Reference to them is requested.

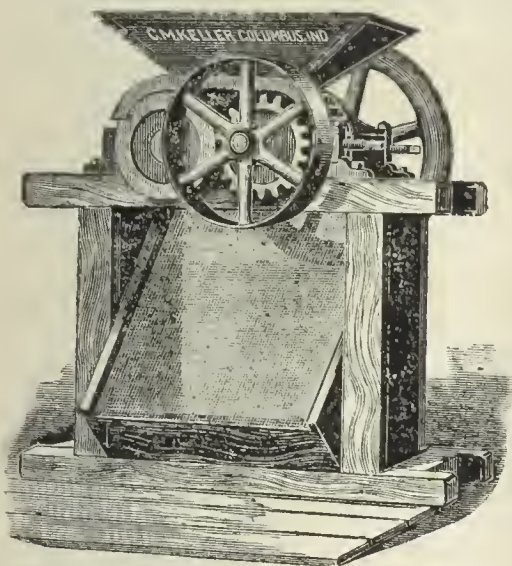

Keller's Adjustable Coke Crusher.

SIMPLE, STRONG, AND DURABLE.

C. M. Keller, Sec. & Supt. Gas Lt. & Coke Co. Columbus, Ind.

Correspondence Solicited.

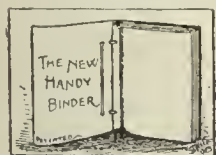

**THE NEW
HANDY BINDER.**

This article may be described as elegant
in appearance, strong, durable, and possessing many special
qualities of its own. It allows the opening of the pages per-
fectly flat, whether one or several numbers are in the binder.
Any number can be taken out and replaced without disturbing
the others. The papers are not mutilated for subsequent bind-
ing in permanent form. The binder is supplied with gilt side
title, and is an ornament to any desk or reading table. The
JOURNAL, filed in the Handy Binder, becomes a volume of great
value, always convenient for instant reference. Handy Binder,
Postage paid, \$1.00.

A. M. CALLENDER & CO., 42 Pine St., N. Y.

**THE
PENN GAS COAL CO.**

OFFER THEIR

Coal, Carefully Screened & Prepared for Gas Purposes.

Their Property is located in the Youghiogheny Coal Basin, near Irwin and Penn Stations on the
Pennsylvania Railroad, and on the Youghiogheny River.

Principal Office:

209 SOUTH THIRD STREET, PHILA., PA.

Points of Shipment:

Pennsylvania Railroad Piers; Greenwich Wharves, Delaware
River; Pier No. 1 (Lower Side), South Amboy, N. J.

Chesapeake & Ohio Railway Coal Agency,

FOR THE SALE OF THE

**Superior Kanawha Gas Coals, Cannelton Cannel,
Also, SPLINT AND STEAM COALS**

From the Kanawha and New River Regions, on the line of the Chesapeake & Ohio R'way.

C. B. ORCUTT, Sales Agent. | OFFICE, 150 BROADWAY, N Y

FRANCIS H. JACKSON, Prest. EDMUND H. MCCULLOUGH, V.-Prest. CHAS. F. GODSHALL, Treas. H. C. ADAMS, Sec.

THE WESTMORELAND COAL CO.

Chartered 1854.

Mines situated on the Pennsylvania and the Baltimore
and Ohio Railroads, in Westmoreland County, Penn.

POINTS OF SHIPMENT:

PHILADELPHIA, BALTIMORE, SOUTH AMBOY, N. J.,
WATKINS (SENECA LAKE), N. Y.

Since the commencement of operations by this Company its well-known
Coal has been largely used by the Gas Companies of New England and the
Middle States, and its character is established as having no superior in gas
giving qualities, and in freedom from sulphur and other impurities.

Principal Office, 224 South 3d St., Phila., Pa.

A. M. SCOTT, PRESIDENT. A. DEMPSTER, C.E., SECRETARY. W. K. GILLESPIE, TREASURER.

MONONGAHELA AND PETERS CREEK GAS COAL CO.,

PRODUCERS OF

Coal Bluff Gas Coal.

MINES LOCATED ON THE MONONGAHELA DIVISION OF THE PENNSYLVANIA RR.,
IN THE CENTRAL PORTION OF THE PITTSBURGH COAL FIELD.

Points of Shipment—Buffalo, Cleveland, Erie, Chicago, New Orleans.

Since the introduction of Coal Bluff Gas Coal it has taken rank among the few first-class Gas Coals, and ac-
knowledges no superior in gas-giving qualities, ease of working, quality of coke, and freedom from impurities.

Milwaukee Agents, F. R. BUELL & CO., - - - Milwaukee, Wis.

General Office, 43 Sixth Ave., Pittsburgh, Pa.

GAS METERS.

GAS METERS.

GAS METERS.



INTERNATIONAL--1876--EXHIBITION.

The U. S. Centennial Commission

HAVE DECREED AN AWARD TO

HARRIS, GRIFFIN & CO.,

Twelfth and Brown Streets, Philadelphia, Pa. No. 49 Dey Street, N. Y. City, and No. 75 North Clinton Street, Chicago, Ill.

FOR THE FOLLOWING REASONS :

The Exhibit consists of a Series of METERS from the Largest Size Station Meters for the use of the MANUFACTURE OF GAS, to those for the use of the ORDINARY CONSUMER. The Instruments are WELL MADE, RELIABLE as to INDICATION, and embody a number of sundry improvements which, with the general character of the Exhibit, entitle the whole to commendation.

Attest—J. L. CAMPBELL,
Secretary, pro-tem.

Signed—A. T. GOSHORN,
Director General

J. R. HAWLEY,
President

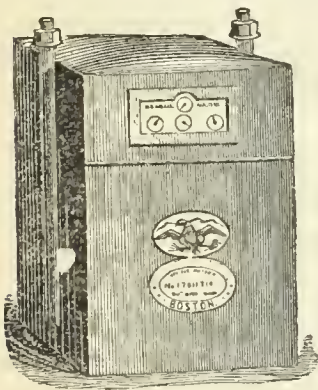

Dry Gas Meter.

With 39 years' experience and the best facilities for manufacturing, is enabled to furnish reliable work and answer orders promptly.

NATHANIEL TUFTS,*No. 153 Franklin Street, Boston, Mass.,*

MANUFACTURER OF

DRY GAS METERS.

Station Meters of any Capacity.

Test and Experimental Meters, Pressure Registers, Pressure Gauges, Pressure and Vacuum Gauges.

METER PROVERS, PHOTOMETERS, STREET LANTERNS, ETC., ETC.

Patent Cluster Lanterns for Street Illumination.

SCIENTIFIC BOOKS.

We are prepared to furnish to Gas Managers, and others interested in the topics treated of, the following books, at prices named:

KING'S TREATISE ON THE MANUFACTURE OF COAL GAS. Three vols.; \$10 per vol.	PRACTICAL TREATISE ON HEAT, by THOMAS BOX. Second edition. \$5.	THE GAS MANAGER IN THE LABORATORY, by a Practica Student. 8vo., Cloth. \$1.50.
GAS MANUFACTURE, by WILLIAM RICHARDS. 4to., with numerous Engravings and Plates, in Cloth binding. \$12.	GAS WORKS—THEIR ARRANGEMENT, CONSTRUCTION, PLANT, AND MACHINERY. \$8.	THE DOMESTIC USES OF COAL GAS, AS APPLIED TO LIGHTING, by W. SUGG. \$1.40.
THE GAS ANALYST'S MANUAL, by F. W. HARTLEY. \$2.50.	COAL; ITS HISTORY AND USE, by PROF. THORPE. \$3.50.	DISTILLATION OF COAL TAR AND AMMONIACAL LIQUOR by GEO. LUNGE. \$8.50.
TECHNICAL GAS ANALYSIS. \$2.80.	THE GAS WORKS OF LONDON, by COLBURN. 60 cents.	A TREATISE ON THE COMPARATIVE COMMERCIAL VALUES OF GAS COALS AND CANNELS, by D. A. GRAHAM 8vo., Cloth. \$3.
GAS MANAGER'S HANDBOOK, by THOS. NEWBIGGING. \$4.80.	THE GAS FITTER'S GUIDE, Showing the Principles and Practice of Lighting with Coal Gas, by JOHN ELDRIDGE. 40 cents.	GAS AS A SOURCE OF LIGHT, HEAT, AND POWER, by C. J. R. HUMPHREYS. 10 cents.
GAS CONSUMER'S GUIDE. \$1.	GAS WORKS, AND MANUFACTURING COAL GAS, HUGHES. \$2.20.	GAS COMPANIES DIRECTORY. \$10.
A GUIDE TO GAS LIGHTING. 40 cents.	THE MANAGEMENT OF SMALL GAS WORKS, by C. J. R. HUMPHREYS. \$1.	GAS VERSUS ELECTRIC LIGHT. 50 cents.
GAS MEASUREMENT AND GAS METER TESTING, by F. W. HARTLEY. \$1.60	MANUAL FOR GAS ENGINEERING STUDENTS, by D. LEE, 40 cents.	PURIFICATION OF COAL GAS, by R. P. SPICE. 8vo. \$3.
GAS CONSUMER'S HANDBOOK, by WILLIAM RICHARDS. C.E.; 18mo., Sewed. 20 cents.	HOW TO MANAGE GAS, by F. WILKINS. Paper. 20 cents.	
A PRACTICAL TREATISE ON GAS AND VENTILATION with Special Relation to Illuminating, Heating, and Cooking by Gas, by E. E. PERKINS. \$1.25.		

The above will be forwarded by express, upon receipt of price. We take especial pains in securing and forwarding any other Works that may be desired, upon receipt of order. All remittances should be made by check, draft, or post office money order.

A. M. CALLENDER & CO., No. 42 Pine Street, New York.**KING'S TREATISE ON COAL GAS.**

The most complete work on Coal Gas ever published. Three vols., bound \$30.

A. M. CALLENDER & CO., No. 42 Pine Street, New York.

GAS METERS.

GAS METERS.

GAS METERS.

GEO. J. McGOURKEY, Pres. WM. H. McFADDEN, Vice-Pres. (Phila.) WM. N. MILSTED, Gen. Supt. & Treas. (New York) WM. H. DOWN Sec.

AMERICAN METER COMPANY.

WET AND DRY GAS METERS.

PRESSURE REGISTERS.

METER PROVERS.

STATION METERS.

PRESSURE & VACUUM REGISTERS.

PORTABLE TEST METERS.

EXHAUSTER GOVERNORS.

PRESSURE & VACUUM GAUGES.

EXPERIMENTAL METERS.

DRY CENTRE VALVES.

CRESSON GAS REGULATORS.

AMMONIA TEST METERS.

GOVERNORS FOR GAS WORKS.

MARSLAND WATER METERS.

BAR AND JET PHOTOMETERS.

Manufactories:

512 W. 22d St., N. Y.
Arch & 22d Sts., Phila.

GAS STOVES,

SUGG'S "STANDARD" ARGAND BURNERS,
SUGG'S ILLUMINATING POWER METER,
Wet Meters, with Lizar's "Invariable Measuring" Drum.

Agencies:

177 Elm Street, Cincinnati.
211 & 216 N. Wells Street, Chicago.
810 North Second Street, St. Louis.
122 & 124 Sutter St., San Francisco.

HELME & McILHENNY,

(Successors to Harris & Brother. Established 1848.)

GAS METER MANUFACTURERS,

CONTINUE AS HERETOFORE AT THE OLD ESTABLISHMENT,

Nos. 1339 to 1349 Cherry Street, Philadelphia, Pa.,

To Manufacture Wet and Dry Gas Meters, Station Meters, Experimental Meters, Meter Provers, Center Seals, Pressure Registers

GOVERNORS, INDICATORS, PHOTOMETERS, & ALL OTHER KINDS OF APPARATUS FOR USE IN GAS WORKS.

From our long practical experience of the business, and from our personal supervision of all work, we can guarantee all orders to be executed promptly and in every respect satisfactorily.

WM. WALLACE GOODWIN, Prest. and Treas.

WM. H. MERRICK, V.-Prest.

S. L. JONES, Sec.

S. V. MERRICK, Supt.

THE GOODWIN GAS STOVE AND METER COMPANY,

Successors to W. W. GOODWIN & CO.

1012, 1014 and 1016 Filbert St., Phila., Pa.

142 Chambers St., New York.

76 Dearborn St., Chicago, Ill.

WALDO BROS., Agents, 88 Water St., Boston.

MANUFACTURERS OF THE "SUN DIAL" GAS STOVES, FOR COOKING AND HEATING PURPOSES.

Dry and Wet GAS METERS, Station Meters (Square, Cylindrical or in Staves) Glazed Meters, King's and Sugg's Experimental Met Lamp Post Meters, Etc., Etc., Meter Provers (sizes 2, 5 and 10 feet), Pressure Guages of all kinds, Pressure Registers, Pressure and Vacuum Registers, Pressure Indicators (sizes 4 inch, 6 inch and 9 inch), King's Pressure and Vacuum Gauges, Dry and Wet Centre Seals, Dry and Wet Governors, Exhauster Governors, Photometers of all descriptions. Letheby's Sulphur and Ammonia Test Apparatus complete—also Testing and Chemical Apparatus of all kinds, and of the most perfect description, for all purposes relating to Gas.

GOODWIN'S IMPROVED LOWE'S JET PHOTOMETER.

Agents for Bray's Patent Gas Burners and Lanterns.

Special attention to repairs of Meters, and all apparatus connected with the business.
All work guaranteed first class in every particular, and orders filled promptly.

G. B. EDWARDS, Mang'r, New York.
E. H. B. TWINING, Mang'r, Chicago.
Represented by S. S. STRATTON.

D. McDONALD & CO.,

GAS METER MANUFACTURERS.

(Established 1854.)

51 Lancaster St., Albany, N. Y. 34 & 36 West Monroe St., Chicago, Ill.

STATION METERS, EXPERIMENTAL METERS, METER PROVERS, PRESSURE & VACUUM REGISTERS, PRESSURE GAUGES, ETC.

Also STAR GAS STOVES, RANGES, and HEATING STOVES.

We use only the very best materials, and employ the most skilled labor, and by our long experience (32 years) and personal supervision of every detail, we feel justified in assuring the public that our goods will give perfect satisfaction. Every Meter emanating from our establishment will bear the State Inspector's Mark, and will be fully warranted by us. Our Annual and Calendar will be sent to Gas Companies upon application:

GAS STOVES.

GAS STOVES.

GAS STOVES.

THE GOODWIN GAS STOVE AND METER CO.,

1012-18 Filbert St., Phila., 142 Chambers St., N. Y., 76 Dearborn St., Chicago.

Agents, WALDO BROTHERS, 88 Water Street, Boston.

WM. W. GOODWIN, PRES. & TREAS.
W. H. MERRICK, VICE-PRES.
S. LEWIS JONES, SEC.
SAMUEL V. MERRICK, SUPT.

SOLE MANUFACTURERS OF THE

G. B. EDWARDS, Mang'r, N. Y.
E. H. B. TWINING, Mang'r, Chicago.
Represented by S. S. STRATTON.

"SUN DIAL" GAS STOVES

The Most Economical, Efficient, and Durable Gas Stove Made.

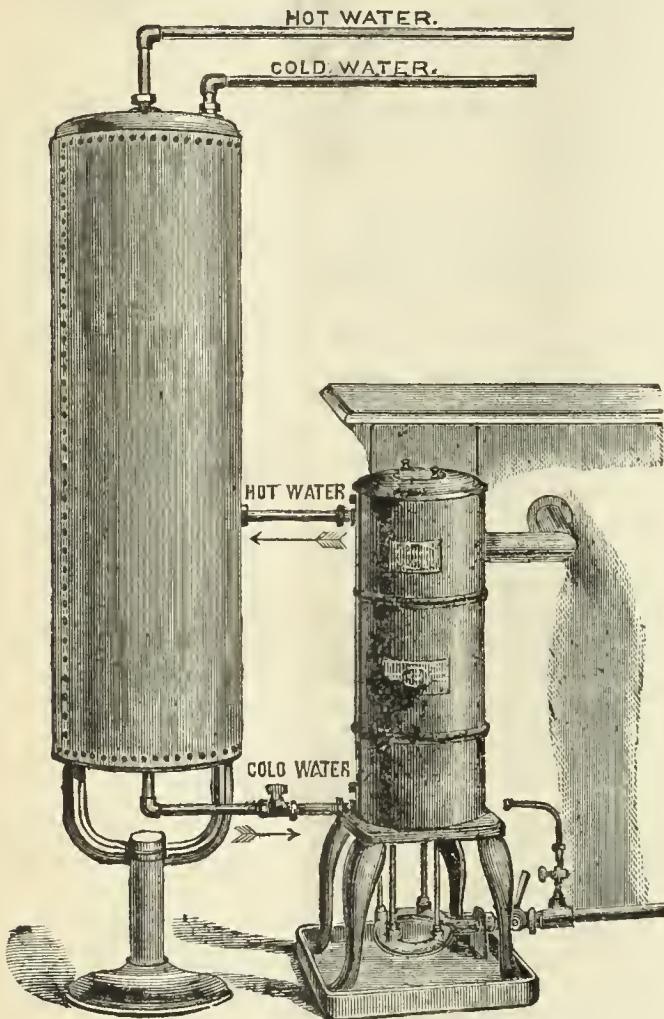

I.—Safety Hot Water Generator and Boiler.

Safety Hot Water Generator and Boiler.

Cut I. represents our Safety Gas Hot Water Generator and Boiler, arranged for home use. This most easy, quick, and economical way of preparing a warm bath, or for heating water for any domestic purpose, entirely supersedes any necessity for the use of ranges or stoves—a great comfort, particularly in hot weather. The boiler being self-filling, as the hot water is drawn off, can never become empty, thus preventing the possibility of any accident.

We beg to call attention to the cast iron pan which is now attached to the legs of the Generator (see illustration). This is to catch the drippings from the Coll, which many persons suppose come from a leak, when in fact they are produced by condensation. This condensation is caused by the hot flame coming in contact with the coil filled with cold water.

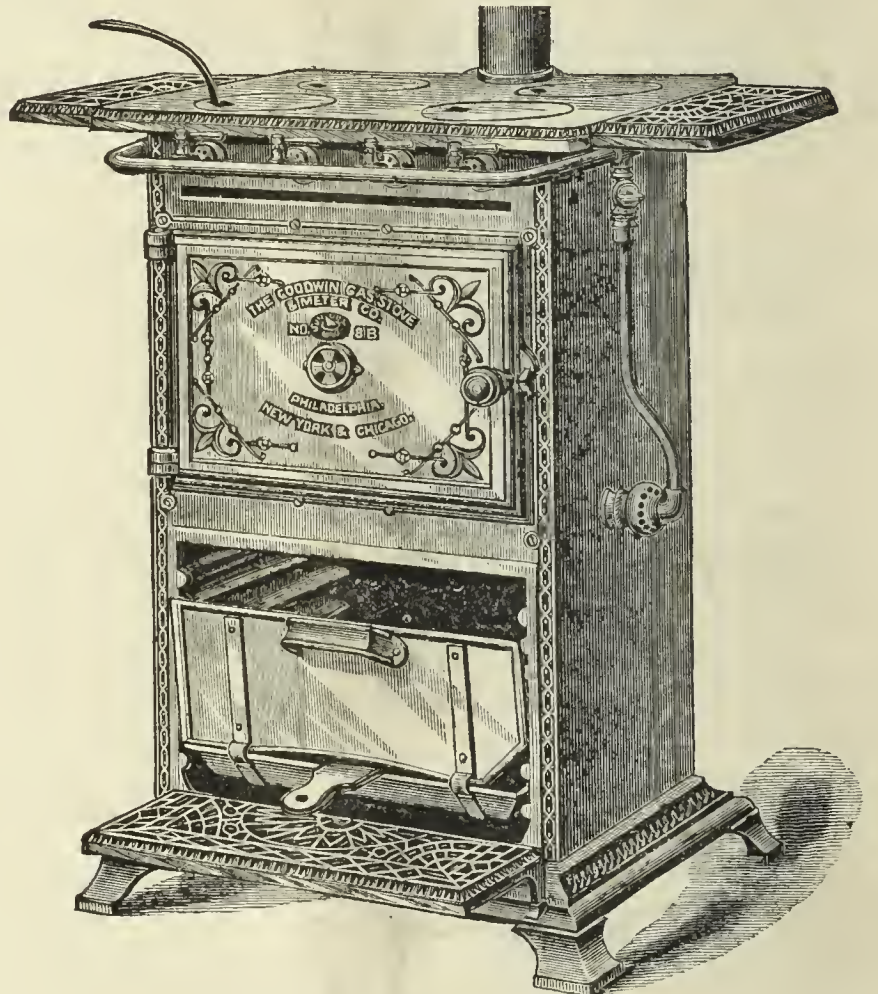

II.—Gas Cooking Stove No. 8 B.

New Style Gas Cooking Stove.

Cut II. represents our New Style Cooking Stove. As will be seen, it has an ornamented cast iron base and front, and extension shelves. The oven burner, which is atmospheric (unless otherwise ordered), is of an entirely new and improved pattern (patent applied for). The ovens are of greater capacity than those of the old style. The top, in conjunction with the outlet pipe, is designed to carry off all products of combustion; hence the outlet pipe must be connected with a flue, or the stove will not work properly.

This Stove has 4 boiling burners in top of hot plate. All fittings are nickel plated. We are making this style of Cooking Stove in the following sizes—viz., No. 7 B, No. 8 B, No. 9 B, and No. 10 B.

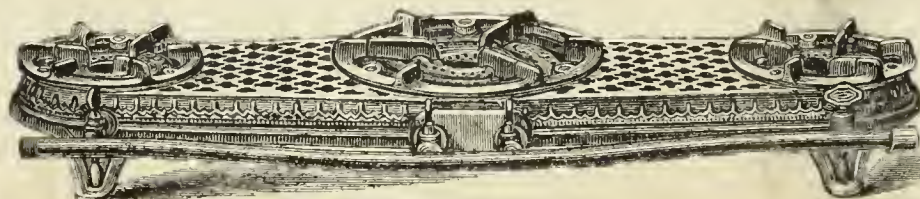

III.—Improved Hot Plate, No. 108.

New Style Hot Plates.

Cut III. represents our New Style of Hot Plates, of which we are making No. 106 (two small boiling burners), No. 107 (two medium sized boiling burners), and No. 108 (two medium and one large boiling burner). See new Catalogue and Price List for further particulars.

THE AMERICAN

GAS LIGHT JOURNAL

RODMAN & KENNY, N. Y.

PUBLISHING OFFICE No. 42 PINE STREET

DEVOTED TO THE INTERESTS OF ILLUMINATION, VENTILATION, WATER SUPPLY AND DISTRIBUTION, & GENERAL SCIENCE.

VOLUME XLVII.—No. 4. }
Whole No. 676.

NEW YORK, TUESDAY, AUGUST 16, 1887.

{ \$3 PER ANNUM,
IN ADVANCE.

A. M. CALLENDER & CO., Proprietors. C. E. SANDERSON, Manager.
JOS. R. THOMAS, C.E., Editor. T. J. CUNNINGHAM, Asst. Editor.

ENTERED AT THE POST OFFICE AT NEW YORK, N. Y.
AS SECOND CLASS MATTER.

Published on the 2d and 16th of each month, at No. 42 Pine Street, N. Y.
Terms of Subscription, Including Postage.—For the United States and
Canada, \$3 per annum. European countries, \$3.50 (15 shillings—18 francs).
All payments to be made in advance. Single copies, 15 cents.

Remittances should be made either by post-office order, registered letter, or
bank draft on New York, payable to the order of A. M. Callender & Co.

Correspondence.—Wishing to make this JOURNAL a gazette of intelligent dis-
cussion to those of our readers who may wish to gain or give information on
the subjects to which its columns are devoted, correspondence is solicited for
publication from all who make the study of those subjects a pleasure or a
profession.

The American News Company, Nos. 39 and 41 Chambers street, New
York, are agents for this JOURNAL. Newsdealers will send orders to them.

Collections are invariably made directly from this office, for subscriptions, ad-
vertisements, etc. We have agents to solicit the same, but they are not
authorized to receipt for money.

Books —We will forward by express, at publisher's lowest rates, any book—scien-
tific or otherwise—to any address in the United States or Canada. No books
will be sent C. O. D.

CONTENTS.

AN Asterisk (*) denotes an illustrated article.

OFFICIAL NOTICE—

American Gas Light Association..... 97

EDITORIALS—

Progress in the Matter of the Proposed Gas Institute..... 98

Levey's Electric Light Primer..... 98

Papers Read at the Recent Meeting of the British Gas Institute..... 99

*Coke, by Charles Gandon, 99—Gas Coke as a General Fuel, by C. E. Jones,
101.

Tests of Refrigerating Apparatus..... 104

*Humphrys' Patent Damper Frame for Furnaces..... 105

*Richard Brothers' Standard Gas Gauges..... 106

ITEMS OF INTEREST FROM VARIOUS LOCALITIES..... 106

Work in Progress at La Crosse, Wis.—Electric Light at Kingston, Can.—
Turned on at Quebec, Can.—To be Lighted by Gas—Likely to be Consolidated
—Dividend Declared—Important Patent Litigation—Death of the President
of the Davenport (Iowa) Gas Company—Baptized Anew—Improvements at
Adams, Mass.—A Queer Case—One Result of the Brooklyn (N. Y.) Gas Rate
—The Waterhouse Electric Lighting System—The Annual Report, English
Patent Office—New Public Works at Canton, Dak. Ter.—Gaseous Doings at
Des Moines, Iowa—Capital Increased—To Supply Electric Light—At Work
on the Station—In Regard to the Sale of the Oneida (N. Y.) Gas Light Com-
pany—Proposed New Gas Company—To Build a New Station Meter—Lowell's
New Holder—Suit against the County of Galveston, Texas—Brother Dennis-
ton at it Again—Oil City (Pa.) Gas Rates—Street Lighting at Belleville, Ills.
—Public Lighting at Detroit, Mich.—Messrs. P. H. & F. M. Roots Preparing
for a Busy Season—Personal—New Gas Company—And yet Another—Messrs.
R. & J. Dempster to Do the Work—A Word or Two from Wheeling, W. Va
—Interesting Figures—Going on with the Good Work—To Light the City's
Wharves—Postponed—To be Run by an Otto Gas Engine—Price of Gas Re-
duced—Consolidated—Will They Get a Contract?—The Subscription Books
are Open—Annual Election, Jamaica Plain, Mass.—A Tie Vote.

Driving Dynamos with Short Belts..... 109

Notes from the West, by "Retort"..... 110

A Fuel Gas Plant in Pittsburgh, Pa..... 110

The Market for Gas Securities..... 110

[OFFICIAL NOTICE.]

American Gas Light Association.

AUGUST 11, 1887.

To the Members of the American Gas Light Association :

The Fifteenth Annual Meeting of the Association will be held in New
York city, on Wednesday, Thursday and Friday, October 19th, 20th and
21st. The convention will be called to order on the morning of the first
mentioned day, at ten o'clock. While it is not possible at this early day
to give all the details of the meeting, I can, I think, give the members
enough information to assure them that those having the meeting in
charge are doing what they can to insure its success.

The difficulty of arranging for the accommodation of the members of
a convention at a single hotel in New York city during the fall months
increases, rather than decreases, year by year, so that it is now found
impossible to provide for the care of all the members of the Association
in a single hotel. The Committee of Arrangements have, therefore, in
deciding on a hotel for the headquarters of the Association, endeavored
to secure one which would be adjacent to other hotels, in order that the
members might be near together, even if the pleasure of being under one
roof were denied them. It has, therefore, been arranged that the head-
quarters of the Association will be at the Sturtevant House, and accom-
modation for the members will also be provided at the Coleman and
Grand, both of which are adjacent to the headquarters. The Sturtevant
is run on the American plan, while the others are maintained on the
European system. It will thus be possible for each member to select
according to his pleasure the plan upon which he will board during his
stay at the convention.

The hall in which the meetings will be held has not yet been positively
decided on, but it is hoped that one in the immediate neighborhood of
the hotels will be secured.

The banquet will take place at Delmonico's. The price of the tickets
I will be able to state at an early date, when I also hope to give more
fully the other details of the Convention.

Touching the literary part of the programme, I can only state that we
have a nucleus to start with, but that is all. It will be remembered that
at the last meeting the Association placed in the hands of the Executive
Committee the duty of securing at least five papers to be read next
October. The Executive Committee referred this matter to a sub-com-
mittee chosen from its own members, which has tried to discharge the
obligation imposed upon it. So far, however, the five papers have
not been secured. The nucleus mentioned is as follows :

"Fuel Gas," by Emerson McMillin, of Columbus, Ohio.

"Illumination vs. Candle Power," by Alex. C. Humphreys, of Phila-
delphia, Pa.

"Utilization of Residual Products," by Chas. H. Nettleton, of Birming-
ham, Conn.

From the above it will be noticed we have only three papers secured
thus far, and only a third of the number required to fill out nicely the
time at our disposal. I have so often spoken of the responsibility which
rests upon each member of the Association, as regards the preparation
of papers, that I feel anything I might say now would be but a repetition

of what I have said in former years. I would therefore drop the subject for the present, merely remarking that if the success of the literary portion of the programme of the coming meeting is to depend on three members, they must indeed be giants if they accomplish the task thrust upon them.

If a member has in mind a subject which he thinks it would be to the advantage of the Association to have discussed at the forthcoming Convention, I would be most happy to hear from him.

Respectfully,
C. J. RUSSELL HUMPHREYS,
Secretary.

PROGRESS IN THE MATTER OF THE PROPOSED GAS INSTITUTE.

The plan proposed by Mr. Frederic Egner, at the last meeting of the Western Gas Association, for the formation of an American Gas Institute, seems to have taken a firm hold on the fraternity, and it is quite likely now that the technical portion of the proposition will be indorsed in a practical manner by our gas makers. The Committee of the Western Gas Association on the American Gas Institute have bestirred themselves to some purpose—we suppose it is only fair to say that Committeeman Egner has properly borne the brunt of the labor—and their labor has not been in vain. They have mailed circular inquiries to every gas company in the country, and those who received the circulars have been, as a rule, quite prompt in forwarding replies thereto. Now, it seems to us that such promptness is in itself an indication of the interest that has been awakened in the Egner project; but when we are in position to add that 95 per cent. of the replies received at St. Louis speak unqualifiedly in favor of the establishment of a bureau for investigation and the “spreading of useful knowledge,” as per the outlines of the Egner plan, we think the ultimate success of the Institute is assured. Moreover, there seems to exist a perfect willingness on the part of those addressed to bind themselves to furnish the necessary funds wherewith to create and support a real live institution that will be of material benefit and help to them in the practice of their industry. Indeed we must say that the outlook for the establishment of a bureau of investigation is very bright, and confidently look forward to an early fruition of the seed sown under such favorable auspices last spring in St. Louis.

But if the sentiment seems to be unanimous in respect of the establishment of a bureau for the spreading of useful gaseous information, a count of hands in regard to the union for mutual defense, while unanimous also, shows that unanimity to be all against the idea. We opine, however, that such negation was more than expected—in fact that it would be made with force; but we hardly believe that Mr. Egner was prepared for the stern onslaught which has been made against that possible corner stone of the suggested Institute. Humanity is pretty much alike in all respects, and that similarity is strongly marked when it comes to a question of fighting other men's battles. “Laugh, and the world laughs with you,” but the world's tear ducts are not at the service of individual mourners. And so it seemingly is with corporations, using the latter word to signify stock companies. Perhaps that is one reason why corporations are said to be soulless, for certainly they have never been known to weep over the discomfiture of one of their kind. Apart, however, from such rambling lingerings after the unknowable, the fact remains that the “union for mutual defense,” and for years that idea has been periodically agitated amongst American gas makers (perhaps gas sellers would be nearer to the mark), has been relegated to obscurity by the combined voice of those who eagerly favor a united effort for technical progress.

Possibly some of those who received a copy of the circulars sent out by the Western Association's Special Committee may not, through press of business or otherwise, have responded to the Committee's wish in the matter of forwarding a reply to the questions asked. To those delinquents we would urge an early compliance with the Committee's request for answers to their message, even if an unfavorable response to the entire project must be made by the replier. Those who are so earnestly endeavoring to get at the true sense of the fraternity in respect to the Institute proposition are entitled to ordinary courtesy at the hands of their correspondents, and we feel sure that any remissness on the part of the latter is not to be charged to wilful neglect. Hand in your suffrages in order that the architects may not grope in the dark.

Before taking leave for the present of the subject under comment, we feel that the following extract (taken from an editorial in the *London Journal*, dated July 19) will be read with interest. The writer, in the course of an article headed, “Papers at the Gas Institute and Elsewhere,” says: “It has been remarked that the standard of communications for

the Gas Institute differs from that of other national societies of the kind; and a little more explanation of the differences may be given here. The papers read at the meetings of the American Gas Light Association come nearest to the British style—as might be expected. Yet the circumstances of gas supply on the two sides of the Atlantic are so essentially different that the technical transactions of the two representative associations cannot be altogether similar. The shadow of competition lies over the professional utterances of our American cousins. They appear in many instances to be men of business—of keen, cutting business—first, and gas engineers afterwards. Many topics, which to Englishmen are of the first importance, are never mentioned at meetings of American gas engineers. The Americans talk well, and often have something good to say; but again and again one is disappointed to find that writers of papers among them are infected with the forced jocularity and trivial verbiage of the ordinary American newspaper reporter. It is very significant of the conditions under which gas supply is conducted in the United States that at the last meeting of the Western Gas Association Mr. Frederic Egner proposed the founding of an American Gas Institute, which organization, instead of being a purely technical body for the cultivation of the science of gas engineering, was to be a ‘federation’ for mutual protection against ‘unfair competition,’ and for investigating inventions relating to gas making processes and apparatus. Of course, it is not for us to say that an organization of this character cannot be established, but regard for the meanings of words requires a protest against the misuse of the term, ‘Institute’ in connection with any such purely pecuniary scheme. It is sufficiently evident that not until the gas industry of America is settled upon a sound basis which shall relieve engineers and managers from daily fears for their means of living, and shall enable them to turn their attention from competitive rates, fighting funds, and other insecure props, to the essentials of gas supply in engineering, administration, and management as understood in the United Kingdom, can we expect the papers of the American gas engineers to approach more closely the best models of such productions.”

Our contemporary seldom speaks of American gas affairs in a style similar to the above, and we are at a loss to understand exactly what is meant in the present instance. Perhaps it is best to ask our readers to judge for themselves, and then all may be satisfied, each in his own way, over the inciting cause. Acknowledging the soft impeachment that our home gas engineers are “men of keen, cutting business,” we nevertheless submit that we have the temerity to hold them to be gas engineers, first and last. While they cannot and do not lay claim to be looked on as successors to either Addison or Macaulay, nevertheless they are abundantly able, through the papers prepared by them, to express their ideas in a manner easily comprehended by those whom they address. Perhaps Mr. Egner would have been closer to precision did he select some other title than that of “Institute” wherewith to designate his “movement;” but at the formal christening that slight defect may be remedied. Further, from the tenor of the replies so far received the “movement” is quite sure to be removed from the bane that seemingly attaches to a “purely pecuniary scheme.”

LEVEY'S ELECTRIC LIGHT PRIMER.

We are in receipt of a copy of a pamphlet which is simply neither more nor less than what is claimed for it by the author—Mr. Chas. L. Levey, of this city—who asserts that it is a “Simple and comprehensive digest of all the important facts connected with the running of the dynamo and electric lights, with precautions for safety, etc., for the use of persons whose duty it is to look after the plant.” Knowing that many gas companies are now operating electric lighting stations in connection with their gas plants, we think that Levey's primer has not made an inopportune appearance. It is just the sort of book that an intelligent foreman would appreciate and value. The object of the author in preparing the book is thus tersely stated in the preface: “It is not supposed that these pages will be of any value to the electrician, but the great difficulty of explaining a science in other than technical terms must be accepted as an excuse. The object of the writer has been to reduce a scientific subject to common-place language.”

BELATED WAIFS.—Just prior to going to press we received a most interesting collection of “Western Waifs,” for which our correspondent, “Diaphragm,” is responsible. Unfortunately the copy hook will have to care for them during the fortnight; but, as good things never spoil, they will make their appearance in our next issue. He introduces his budget by saying: “The gas men of the Buckeye and Hoosier States all speak hopefully of the future, and, without exception, report a decided increase in business this year as compared with that of 1886.”

Papers Read at the Recent Meeting of the British Gas Institute.

[In accordance with our usual custom we herewith commence the republication of some of the papers read at the 24th Annual Meeting of the Gas Institute. For our report of same we wish to acknowledge our indebtedness to the *London Journal*.]

Mr. Charles Gandon, of London, read the following paper on

COKE.

The subject of this paper is one that has not often occupied the attention of these meetings, probably because, although the advantageous use and disposal of coke is of importance to gas managers, there does not, at first sight, appear to be much that can be said upon it, as the varying conditions under which it has to be produced do not admit of any general principles being adopted in its treatment. I am afraid also that it will not greatly interest many who are present to-day, as the low cost of coal, in most of the northern and midland districts of England, and the quality of the coke obtained, more particularly where cannel is largely used for gas making, renders coke a question of minor importance, although the difficulty in disposing of it may be consequently increased. In the southern parts of England, however, or where the cost of coal is high, the successful working of a gas undertaking depends in no small degree upon finding good markets for the residual products, and especially for coke. The great fall, during the last year or two, in the value of all residuals produced in gas making, renders it interesting to consider whether means can be devised for increasing the demand for any or all of them. Without being prepared to indicate such means, I am induced to offer these few remarks, hoping thereby to produce a discussion, from which the experience of others may be obtained and some benefit arise.

The recently published reports and accounts of most gas undertakings, both in England and on the Continent, show that the amounts realized for residuals have, almost in all cases, fallen off to a serious extent. This applies perhaps more especially to tar and ammonia; but the value of coke has also decreased considerably in many places, and, in most cases, the latter does not appear to realize its proper value. It is generally assumed that the calorific value of ordinary coke is about equal, weight for weight, to that of coal—that is to say, that a pound of coke will evaporate the same quantity of water as a pound of coal; but if the prices obtained per ton of coke are compared with the cost per ton of coal, it will in most instances be found that the coke has to be disposed of much below its relative calorific value.

By details obtained from a number of gas works in various parts of the kingdom, as to cost per ton of the coal and the prices realized per ton for the coke sold, I find that, during the last half of the year 1885, the prices per ton obtained for the coke varied between 104.4 per cent. and 37.7 per cent. of the cost of the coal per ton; and for the last half of the year 1886 the prices varied in the same way between 118.7 per cent. and 40.3 per cent. of the cost of the coal per ton. In some cases the coke appears to have been sold for even more than the full value; but in many others less than half that value was obtained. These percentages do not seem to indicate that the relative values of the coal and the coke differed to any great extent during the two periods referred to; and the inference might be drawn that the recent reduced amounts realized for the whole of the residuals are not generally due to a fall in the value of coke, but there are instances where large reductions in the prices of coke have occurred during the last six or twelve months. The ever-increasing quantities produced for sale will, no doubt, in some measure account for the lesser value; but there seems reason to suppose that undue competition may also in some cases have contributed to its depreciation.

Coke produced in gas making is principally used for manufacturing and domestic purposes. For some mechanical purposes—such as smelting and for locomotive boilers—it is unsuitable, not being sufficiently dense, and not developing sufficient heat for the furnace space occupied; but for ordinary steam boilers, and for numerous mechanical operations, there seems to be no adequate reason why such coke should not be more extensively employed than it is, provided it is as cheap or cheaper than coal. A larger grate surface is required, so that the full effect cannot be obtained in furnaces intended for coal. But this can be easily supplied in most cases; and the freedom from smoke is one great recommendation for coke. It has been thought to have an injurious effect upon boilers, on account of considerable heat being developed in the vicinity of the furnace; but, by suitably shielding the parts likely to be exposed to such heat, no inconvenient result need arise from this. Numbers of boilers could be referred to which have been worked with coke for many years without suffering greater deterioration than would have

occurred if coal had been used; indeed, most gas works would furnish proof of this, as steam boilers in such works are very generally fired with coke or even with breeze. Of course, where space is of importance, either for furnace area or for storage room, as in the cases of locomotives or sea-going steamers, coke may be out of the question; but there are so many instances where it might be advantageously employed that its merits do not seem to be so generally appreciated or understood as they should be.

Coke appears also to be quite as little appreciated for domestic purposes. It may generally be purchased at about half the price of coal, and is better and more economical than the latter for many household requirements; yet its use, even by the poorer classes, is rather the exception than the rule. The reason for this has often been asked without being satisfactorily answered; apathy on the part both of buyer and seller may perhaps have something to do with it. We have so long been accustomed to supply our wants with coal that the idea of seeking a cheaper substitute does not occur to many. Coke as usually sold also needs more attention than coal in ordinary grates; and this is frequently considered a drawback to its use, especially by servants. Some time is required, after kindling a coke fire in a common grate, before the full heat is given out; and if the fire is allowed to burn too low before replenishing with fresh coke it is again some time before much heat is obtained. This occurs also with coal, but not to so great an extent; and a coal fire may be stimulated into activity by stirring, while with coke this does harm rather than good. The sluggish kindling of the coke may, however, be remedied, either by replenishing the fire with small quantities at more frequent intervals, or by mixing coal with it; and, if grates are employed in which an increased draught can be temporarily applied when fresh fuel is added, this objection would be still more completely removed.

Closed stoves are so little used in England that it is useless to say much about them; but they possess so many advantages that they should be more in demand, especially for warming halls, passages, and staircases. There is perhaps no country in the world where the houses are so defectively and so extravagantly warmed as in England, owing to no attempt being made to heat the air before it enters the apartments. There are numerous good slow-combustion stoves which, with a small consumption of coke, and with very little care, would remedy this, if fixed in entrance halls or other suitable positions; but any provision for this is rather the exception than the rule in English houses, although of late years gas stoves are becoming more in favor for such purposes. While encouraging the use of these, however, the sale of coke might be considerably increased if attention could be more generally drawn to the advantages of closed stoves for similar purposes. Wasteful as is our system of open coal fires, I am too great an admirer of their cheerful effect in our dull winter climate, and of the assistance they afford for ventilation, to advocate the general substitution of closed stoves in our dwelling-rooms. But I do think that the effect of the latter might be improved, and increased comfort and economy obtained, if they were supplemented by some means of warming the air before it enters the apartments; and I believe that no better or cheaper way can be found for doing this than by the use of closed stoves fired with coke.

Another objection to the use of coke is that, as produced in gas making, the pieces are generally so large that they will not burn freely in an open fireplace. To remedy this it is now in many gas works being broken by hand or by machinery to more convenient sizes, which, to a great extent, overcomes the difficulty before referred to, of its being troublesome to burn in ordinary grates; and I feel so convinced that, by this means, the demand for coke may be materially augmented that I would strongly urge all gas managers to try it, if they have not already done so. At the Crystal Palace District Gas Company's works coke has been sold so broken for several years, and much advantage obtained thereby. The district in question is practically a residential one, there being but few manufactories or other places where large coke could be used. During the last half of the year 1886 nearly 40 per cent. of the coke sold in the district was broken; and the greater part so sold would probably not have been disposed of at all if it had not been broken. The price charged for broken coke is 1d. per cwt. above the cost for the ordinary coke; and I believe that double the extra charge could be easily obtained. The labor for breaking costs 10d. per ton; and 10d. per ton is about sufficient for the cost of working the gas engine and for sundries. More breeze is necessarily produced, but this does not amount to more than 1 cwt. of breeze per ton of broken coke. Where the selling price of coke is high, the additional 1d. per cwt. may not be quite enough to cover the whole cost; but even if a small loss arises from the breaking, there may still be an advantage if the general price of the coke sold can be maintained higher. This broken coke is particularly adapted for use in

kitcheners or closed stoves, being much more economical than coal, and causing no choking of the flues by soot.

An illustration (see cut) is on the wall of a coke breaker which has been in use for several years at the Crystal Palace District Gas works, and has been found very efficient. The breaking portion consists of a hopper, at the bottom of which are fixed two horizontal shafts, having 12 serrated $\frac{1}{4}$ -inch steel disks mounted upon each, with distance pieces between each disk. These shafts rotate toward each other by means of gearing, and draw the coke down from the hopper, cutting or breaking it in its passage. The distance apart of the disk shafts can be varied by weighted levers attached to the two movable bearings of one shaft, so as to break the coke to any size needed. This breaker, when first used, was raised only a few feet from the ground, and the coke was thrown into the hopper by baskets. This was found to require considerable labor, and the breaker was afterward mounted upon an elevated platform 11 feet above the ground (as shown by the drawing)—the coke being raised by an elevator and tipped into the hopper. Much saving of labor is effected by this, not only for feeding the coke into the hopper, but also by enabling the broken coke to spread out on the ground without requiring to be shoveled away. In fact, the advantage of elevating the breaker has been found so great that, for a second one recently erected, the height above the ground has been increased to about 15 feet, which

one, which is being largely adopted, especially as a hand-breaking machine for small works; and some years since I saw a very excellent coke breaker at the York gas works, made by Messrs. Smith, Beacock and Tannett, of Leeds, and which was described in a paper read by Mr. Sellers in 1879 before the then British Association of Gas Managers.

Another point in the disposal of coke is the consideration whether selling by weight or by measure is preferable. In the north of England sale by weight is probably more general; but in the south, and especially in the neighborhood of London, or in what are termed the "Home Counties," measure is in many places the rule. Before the Weights and Measures Act of 1878 became law, the general practice in selling by measure was to reckon the chaldron equal to 36 heaped bushels; some uncertainty existed as to the cubical capacity of the heaped bushel, and it was manifestly difficult, if not impossible, to measure coke heaped in a measure such as described by the previous Acts, while it was equally impossible to measure a strike bushel, as required by the new Act. In some cases, after the passage of the Act of 1878, coke was sold by the chaldron of 36 strike bushels, instead of 36 heaped bushels, or about 48 strike bushels, as before. This caused much confusion, as purchasers were in doubt as to what quantity of coke would be received for a chaldron.

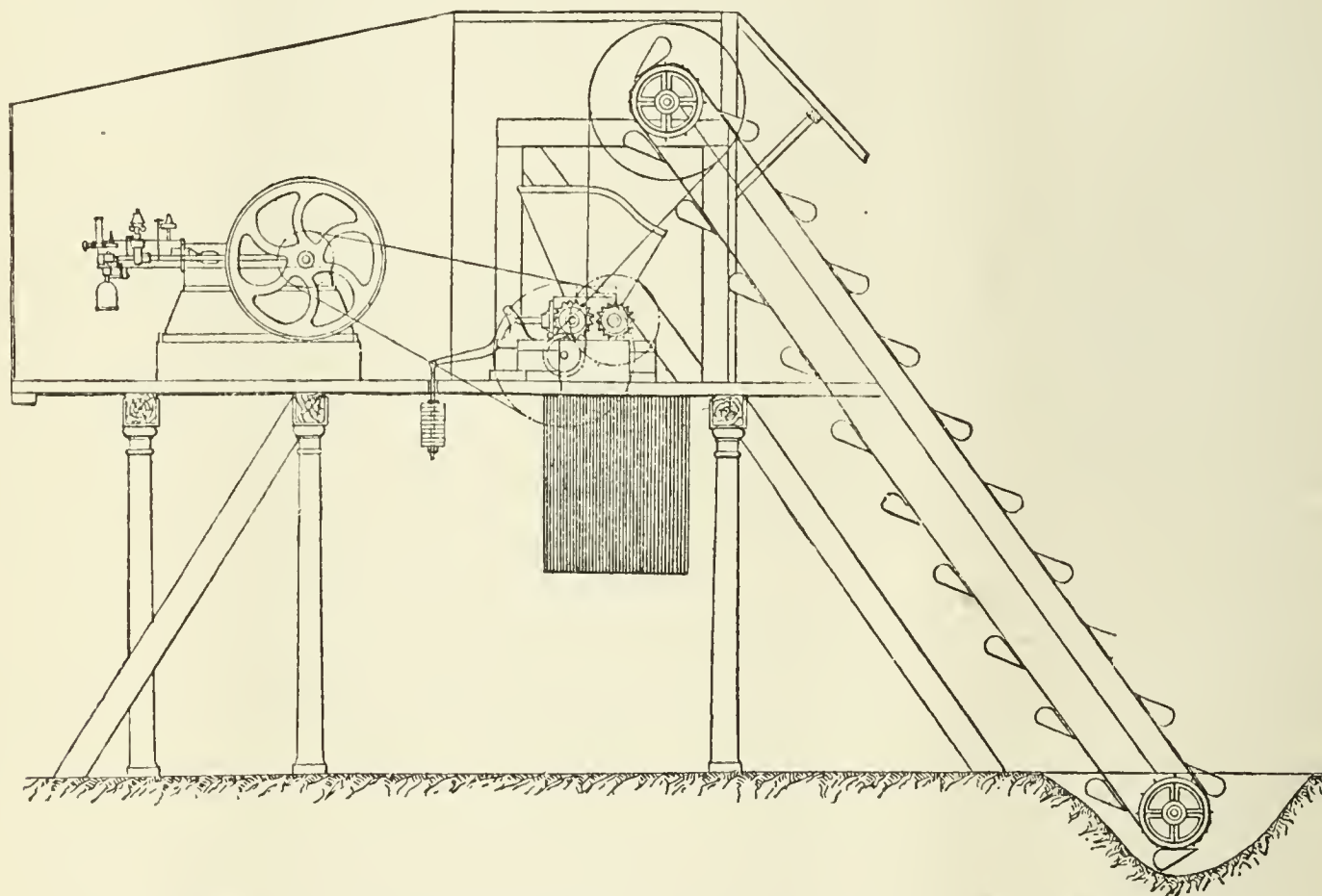

Coke Breaker in Use at the Works of the Crystal Palace District Gas Company, London.

will admit of the accumulation of larger heaps of broken coke without labor. The coke as it leaves the breaker falls down inclined screens for the separation of the breeze. This breaker, as described, and including the elevator, is worked by a $2\frac{1}{2}$ -horse power engine, and 8 to 10 tons of coke can be broken with it per hour. But the engine is scarcely powerful enough to work the breaker and elevator up to their full capacity, and it is proposed to replace it by one of $3\frac{1}{2}$ -horse power. The broken coke is, of course, variable in size; but for most purposes this is not found an inconvenience, provided the largest pieces do not much exceed 2 inches cube.

At the Paris gas works broken coke has been supplied for many years, and it is there divided into three or four sizes by means of a revolving cylindrical screen, with meshes of different sizes—varying prices being charged according to the size required. This plan has many advantages, especially where, as in Paris, coke is so generally used for many purposes. But the cost of breaking is thereby increased, more breeze is produced, and the sale is complicated; so that, until a good demand for variable sizes can be anticipated, it may perhaps be sufficient, in the first place, to familiarize English consumers with the use of the coke as it leaves the breakers simply freed from breeze.

The breaker used at Sydenham has been found to answer exceedingly well; but there is no reason to say that it is better than several others that can be obtained. Messrs. Thomas and Somerville have introduced

A further difficulty in selling by measure is that, if the coke has to be sent any distance, it will decrease materially in bulk by shaking together and the breakage of the pieces—giving rise to complaints that the proper quantity is not being received, although good measure may have been given when loading it.

Shortly after the passage of the Act of 1878 a meeting of the members of the Southern District Association of Gas Engineers and Managers was held in London, to consider the desirability or otherwise of selling by weight; and although some members then present were in favor of measure, it appeared that the more general preference was for weight. At that meeting I was an advocate for measurement. Further experience, however, caused me to arrive at the opposite conclusion, and since July, 1884, coke has been sold at the Crystal Palace District gas works by weight. The change appears to have given general satisfaction to purchasers, as complaints as to quantity delivered are now very rare; whereas, when selling by measure, they were more frequent. Selling by weight involves somewhat more labor, and there is a difficulty as to the increased quantity of water the coke may hold in wet weather. If sold soon after being drawn from the retorts, this question of water is of very small importance; but if the coke is stored in the open for any considerable time there is no doubt a large increase in weight in wet weather—amounting, as I have at times found, to from 15 to 20 per cent. This is, however, only on occasions when large stocks have accumulated.

The regulation of the selling price of coke, so as to dispose of it to the best advantage, is a point requiring much consideration, and one upon which there necessarily exists considerable difference of opinion; but I think it may be broadly assumed that it should be disposed of as soon as possible after being produced, as the quality and quantity both deteriorate by keeping, and expense is in most cases incurred for stacking. There is, of course, in some instances, a largely increased demand for coke at certain seasons, which may necessitate the accumulation of a stock; but as a rule the manager who can dispose of his coke as it is made is in a fortunate position. The demand must necessarily vary with the localities. In manufacturing districts all the coke produced can, as a rule, be sold within the area of the gas supply, without there being so much need to cultivate a demand for it for domestic use. But in residential districts this is frequently not the case; and it is often impossible to get rid of all the coke without sending it considerable distances, and probably coming into competition with the produce of other gas works. Much prejudice is sometimes caused by this; and it has been urged that one gas undertaking ought not so to compete with another. It cannot, however, be always avoided, as, if not directly done by the gas management, it will be by dealers, if the differences of price are sufficient. Coke is at times sold to distant consumers at largely reduced rates, in order to keep up the price in the locality where it is produced; but the policy of this appears to me to be very questionable. It is doubtful whether so good an average price is thereby obtained; and it seems desirable to give the gas consumers of the district where the gas is made the benefit of the lowest prices. Instances could be given where gas companies at great distances apart have been simultaneously sending coke into each other's districts, and thus evidently selling at lower prices, by at least the cost of the carriage, than would have been obtained if each company had kept within its own area. I believe the best policy will be found to have one uniform selling price, or, at the most, only small variations therefrom, and to so regulate this selling price that the accumulation of a large stock is avoided. At all events, it seems to me to be wrong in principle to make large reductions to purchasers at a distance, which is, as a general rule, unnecessary and prejudicial to all concerned, except perhaps to the carriers.

Most gas managers are more or less troubled with the disposal of breeze. One drawback to the sale of broken coke is that the amount of breeze is augmented; and it is the more necessary to consider whether any means can be found for getting rid of it. The increased quantity will not, I think, be found in most cases to be a very serious obstacle, as it does not exceed 1 cwt. per ton of broken coke sold; and if this is paid for by the extra price charged, the resulting breeze is so much to the good, unless indeed payment has to be made for its removal. I think, however, that the various purposes to which breeze may be applied are not in general sufficiently well appreciated. I can remember the time when the whole of the breeze could be disposed of at fair prices—being in demand for ballast burning, road making, and other purposes; but at the present time, with increasing production of breeze, and a partial cessation of building in our locality, there is an undoubted tendency for the breeze heap to extend in size.

The idea of forming breeze mixed with tar into a compressed fuel is by no means new; but this does not appear to be done in England to any extent, probably because of the difficulty of making such fuel without the admixture of so much tar that too much smoke is given off in burning. The Paris Gas Company has adopted this plan for many years, and has large and powerful machinery for manufacturing compressed blocks with tar and breeze, which is probably successful, because very great hydraulic pressure is employed, and the quantity of tar required is thereby considerably reduced. Many years since Mr. George Anderson also introduced a machine for making tar and breeze fuel, samples of which I have seen; but they appeared to contain too much tar, probably because sufficient pressure could not be employed. It would, however, be interesting to know if this machine is still used, and, if so, with what results.

A mixture of tar and breeze also makes an excellent footpath, not perhaps quite so durable as where gravel can be obtained; but, where the latter is expensive, breeze is a very good substitute. We have footpaths at the Crystal Palace District gas works made in this manner, which, to my knowledge, have been in use for over ten years, and are still in good condition. In laying such paths the great point, as in the preparation of tar fuel, is only to employ sufficient tar to effect the binding of the breeze; and this can be best accomplished by using a plentiful supply of water when mixing the tar, which is thereby effectually distributed through the whole of the breeze, while this can only be imperfectly done if the tar and breeze are mixed alone. A mixture of 24 gallons of tar per yard of breeze will make an excellent footpath if prepared in this way.

Fine breeze is also a good substitute for sand for mortar, even if sim-

ply mixed by hand, as is usual with sand; but the quality of the mortar is much improved by being ground in a mill, although this is also the case with sand. Such coal ash mortar is objectionable for some purposes on account of its dark color; but for inside work this is of no consequence, and for exteriors it may be obviated by pointing with sand mortar, if necessary.

At the Crystal Palace District gas works large quantities of concrete have also been used composed of breeze and clinkers, with lime or cement. We have there a tar and liquor tank of 400,000 gallons capacity, constructed entirely, including the arched top, of concrete made of these materials. The ground, however, in which the tank is built is a stiff clay, quite water-tight in itself, so that the chief duty of the tank walls is to hold up the ground; but we have other tanks above ground, built in the same manner, which have been made water-tight with cement rendering. Concrete composed of 10 to 12 parts of breeze to 1 part of cement would certainly be quite porous; but where the ground itself will not hold water there would be no difficulty in forming a water-tight tank with such concrete, either by clay puddle externally or with cement rendering internally. The foundations of all retort houses and other buildings, and for all apparatus at Sydenham, have for many years been formed of breeze concrete, the extensive use of which for such purposes has prevented the accumulation of breeze to any inconvenient extent.

Perret's breeze furnace, which has been introduced in England by Messrs. Bryan Donkin & Co., may also be mentioned as another means for utilizing this material which appears to merit more attention than it has yet received. This furnace can be fitted to any ordinary steam boiler, and consists mainly of thin deep fire bars placed closely together, the bottom edges of the bars being immersed in a trough of water in the ashpit, and the ashpit being closed. The breeze is spread upon the bars in thin layers, and a forced draught is blown through it from the closed ashpit by a fan or injector. I have had some experience of this furnace, and find it will burn the finest breeze; and the bars, being kept cool by dipping into water and from the air being forced between them, are not readily destroyed. Some inconvenience occurs from the fine fuel being carried by the draught into the flues; but with care not to work the air at too much pressure, and with suitable arrangements for readily clearing the flues, no great trouble arises from this. Weight for weight, more breeze is required than when coke or coal is used; but, with the relatively small value of the breeze, it is considerably cheaper.*

With sufficiently large retort furnaces and suitable means for the admission of air, breeze may also be consumed in these furnaces. At Sydenham this has been done to some extent, both with ordinary furnaces and in conjunction with tar. Furnaces have also been recently constructed in which it is hoped to work entirely with breeze; but as these have not yet been used, I cannot speak of their success.

I must apologize for having occupied so much time with these remarks; but, having experienced the heavy depreciation in the value of residuals, I am perhaps inclined to attach more importance to the subject than it deserves. If the few suggestions I have endeavored to make induce other members to give their views to the meeting, the time I have taken up will not have been altogether wasted.

Mr. Gandon was followed by Mr. C. E. Jones, of Chesterfield, who read the following paper, entitled—

GAS COKE AS A GENERAL FUEL.

It may be as well to indicate at the outset that one of the primary objects of this paper is to provoke discussion; its author being convinced that more technical advantage is secured by the collective experience of many than the isolated experience of one individual, however desirous or competent he may be to impart information to his professional brethren—a qualification not claimed by the writer of this paper. Frequent comparing of notes is of considerable benefit to all persons engaged in the same or similar paths of industry. Hence the author has been induced to introduce the question of gas coke in the hope of eliciting from those in a more favorable position than himself information respecting its manifold applications, and the means adopted for its disposal and extended uses. The question of the consumption of coke in gas works involves many points which may be advantageously discussed by the meeting; but it is by no means desired to confine observation to what takes place in a retort furnace. Rather is it sought to deal with coke from the point of view of the consumer; and by teaching such how to employ the

* Messrs. B. Donkin & Co. state that the number of pounds of water evaporated per pound of fuel is as follows:

With breeze or dust gas coke as burnt on Perret's grate.....	5½ lbs. water.
With dust Welsh coal as burnt on Perret's grate.....	8½ " "
With ordinary Welsh coal on ordinary grate.....	9 " "
With large gas coke burnt on ordinary grate.....	7½ " "

fuel to the best advantage, augment the area of absorption to the benefit of gas undertakings and the community generally.

While attempts are being made to introduce smokeless coal into large towns for domestic consumption, it may not be out of place to examine the claims of gas coke to be considered one of the chief agents at command for purposes where a smokeless solid fuel is required. Were we called upon to manufacture a superior solid smokeless fuel to supersede bituminous coal, in all probability we should have produced a similar if not the identical article known as gas coke, since it certainly possesses in an eminent degree the qualifications of such a fuel. By the aid of geological research it would be easy to show that the cosmogonies of our most ancient systems are unreliable as to the date of man's advent on the earth, and of his knowledge of coal and the practical uses to which primitive humanity applied the "black diamond." It is certain that coal was used in the "flint age," since an ax and other tools of this description and siliceous material have been found in disused coal measures where it was evident they had been employed in "winning coal." Many instances might be advanced connecting what we are pleased to call "primitive" man with coal. But it would be equally easy to demonstrate, on purely historical and logical grounds, that the present method of burning coal in an open grate with an exit for the smoke in the roof is, despite the proud boast of the march of civilization, as primitive, barbarous and wasteful as that adopted by the ancient Britons ages before the Roman invasion of Britain. In the last year of the reign of King Edward I., in consequence of the smoke created by "Sea-cole," as it was called, on account of its being sea-borne, its use was prohibited by royal proclamation (1273). The restriction was removed in the succeeding reign; and from that time till the present the "smoke nuisance" has been tolerated with lamentable results. The atmospheric condition of large towns is injurious to health and a deadly foe to longevity, solely due to the use of bituminous fuel. Were smokeless fuel employed the atmosphere would be entirely free from the infliction of smoky fogs. Sanitarians have overlooked the fact that gas coke is the panacea for the evils complained of. The remedy of King Edward might have proved worse than the disease; but it is nevertheless a fact that for 600 years the minds of men have been exercised to devise means to abolish the smoke nuisance, while here is offered a perfect cure, inexpensive and effective, and not even requiring the protection of a "patent." Smokeless fuels abound on all sides of us, and appear to be neglected. History is said to repeat itself; and it is remarkable that a return to the smoke legislation of Edward I. has been proposed in this year of Jubilee. Edward I., it might be observed, succeeded a King who rejoiced in a Royal Jubilee. How complete would be the parallel should the successor to Her Majesty Queen Victoria re-enact laws forbidding the use of bituminous coal.

Taking the volatile constituents of a ton of bituminous (Derbyshire) gas coal at 870 pounds, we have 1,370 pounds of coke, or, say, 61.16 per cent. of solid residue, and 38.84 of volatile and liquid products. The latter percentage represents a factor of the highest importance to the gas manufacturer. The former is not nearly so valuable. Why is this? The author believes that the answer is to be found in the indifference with which the general public regard the question of atmospheric pollution, and their want of knowledge of the excellent qualifications of gas coke as a smokeless fuel. It answers every purpose required of it when employed in domestic purposes. Its advantages over coal are manifold, as will be considered later on. Theoretically the extraction of the hydrocarbons or smoke-making constituents preparatory to employing the fuel in an open grate harmonizes perfectly with scientific teaching. It is perfect and solves the problem of smoky chimneys and atmospheric pollution completely. With this truism before us it is singular that gas coke commodity of comparatively low value. The present affords an excellent opportunity for endeavoring to advance the article in public estimation, not only by entering into competition with King Coal in the domestic arena, but in manufacturing circles as well. It is a mistake to suppose that coke will not burn well in ordinary open grates. It has been objected that the use of coke would entail enormous expense on property owners by necessitating structural alterations in dwelling houses. This is not so when the fuel is broken to suit the size of the grate. Nearly all grates will burn coke more advantageously than coal. The latter is broken to suit the grate; why not coke? Again, it is said a strong draught is needed to keep up combustion. This is also fallacious. The whole question, it appears to the writer, turns upon the size of the fuel as adapted to the form of the grate. Some fireplaces require coke the size of hazel nuts; others burn 2-inch cubes and upwards without difficulty. When the most suitable size of the coke has once been ascertained, no trouble is afterwards experienced.

One cause of the popularity of bituminous coal in households is its kindling properties. Coke fires can be started without coal; but where

time is important a few pieces of coal will assist the operation. Coal, when burning, cakes, and requires the use of the poker; coke falls together as it burns away, and requires but little attention. Coal burns with much smoke and flickering flame; coke, on the contrary, burns with a cheerful glow, with an absence of flame or smoke, and is far cheaper, dispensing as it does with the domestic evils known as "sweeps," with all the concomitant horrors attending their operations. Chimney sweeping alone is an important item in household economy, usually amounting, where coal is used, to 1s. and upwards per chimney per annum; but some chimneys and flues require cleansing three or four times a year, thus trebling or quadrupling the estimated cost. By using smokeless fuel this expense is entirely saved, besides the enjoyment of immunity from conflagrations, or the risk of being burnt out by means of chimneys taking fire. Should the next race of architects discard the open grate, and adopt the more scientific mode of heating dwellings and other buildings by hot water, no better fuel than coke is at present in the market, regard being had to its selling price. The use of coke increases the sum of domestic comfort and happiness, encourages longevity, promotes the purity of the air, and confers hygienic blessedness on suffering humanity. Bituminous coal does not, from the very nature of its composition, possess the above attributes; but when used in open grates, brings many evils in its train, with which, unfortunately, humanity is too familiar. This is no "fairy fable" or matter of conjecture, but clear to demonstration. It is not theory, but practice. For years gas coke has been employed in open grates and kitchen ranges in the domestic economy of the author, to the exclusion of coal, which is only tolerated for kindling purposes, or when mixed with inferior coke for greenhouse fires. In the offices of the Chesterfield Water Works and Gas Light Company, the same class of fuel is used with satisfactory results, coal being prohibited. Let other gas managers pursue the excellent practice of preaching by example and not precept alone, and gas coke will soon be established as a popular household fuel. After domestics become accustomed to its use it is preferred to bituminous coal. Experience abundantly justifies these observations.

Any steam user desirous of exercising economy in raising steam would do well to study the calorific value of fuels. Especially would he be benefited by a reference to the experience of Mr. Henry Hack, at the Saltley Gas Works, Birmingham, which that gentleman detailed in his able inaugural address to the Midland Association of Gas Managers last February. There he will find that the cost of evaporating water is largely in favor of coke as against "slack." But on theoretical grounds it can be shown that for steam purposes a porous fuel like coke is much superior to "slack" or colliery refuse, which contains, weight for weight, a large preponderance of mineral or foreign matter. Let any person employing steam daily make an honest test with coke, either in combination or without "slack;" and it is not too much to say that he will certainly decide in favor of coke. Perfect combustion cannot be secured with coal, on account of the interior of the mass being subjected to the process of destructive distillation. Coke offers many advantages in this respect over coal. When it is remembered that the quantity of carbon present in an average sample of gas coke is over 88 per cent., and that anthracite coal contains very little more—usually about 2½ per cent.—it will be readily conceded that we have a fuel under consideration of a very high order, evolving a heat duty of over 12,000 units per pound; pure carbon yielding, when burnt into CO₂ (carbonic acid), 14,500 units of heat only.

Gas coke is applied on a small scale to so many purposes that a mere enumeration of them would be tedious. It even competes with oven coke in small foundries, and some brass founders use it exclusively. It is also well adapted for forging purposes of nearly all classes, when care is taken to insure the correct size for the purpose required. The size needed by blacksmiths is a most important consideration. Blacksmiths engaged in light work require the hearth fuel much smaller than others forging heavy work. It is obvious that the man who makes an ax requires larger fuel than one who forges a penknife. Cleanliness in screening the coke is essential, and for steel forging, especially in cutlery, a coke yielding much sulphur in the ash is unsuitable for this purpose. If it be known that the coke is "sulphury" it is better not to recommend it for blacksmiths' use. The practice of the author has been to supply coke for manufacturing purposes as small as horsebeans, and as large as will pass through a 1½-inch circular ring, or thereabouts. Walnut size is perhaps in greater demand, and suits coach smiths, shoeing smiths, and general all-round work. As a rule, preference is given to uniform-sized coke—that is, without much variation from the given size. The disposition of gas coke to break up cubiform rather than laminar enables this requirement to be easily satisfied. From observation it appears that the quantity of coke used for domestic purposes during the summer

months is but one-fifth of that used in the winter quarter. That used for manufacturing purposes, allowing for the variation and vicissitudes of trade and commerce, may be taken as a constant all the year round.

In malting districts coke is found to be an excellent fuel for drying malt. Here, again, it may be desirable to observe that it must be well "burnt off," and contain a minimum of sulphur. If a large proportion of sulphur be present it spoils the quality of the malt. The finest coke screenings are utilized for burning lime and cement; and the ashes mixed with tar make good asphalt walks. Attempts are being made to convert coke dust, "slack" and tar into briquettes. It requires a little pitch also to bind the materials together; and when made small the briquettes will burn in open grates. So far, however, as the author's experience extends coke for open grates is infinitely superior to briquettes. The advantages of using coke for heating public buildings—such as churches, schools, workhouses, and other institutions now warmed by hot water apparatus or hot air—does not appear to be sufficiently appreciated; and much may be done by gas managers in their respective localities in making known its qualifications to the public advantage. For greenhouses or hothouses coke is well adapted, either alone or mixed with a little small coal. When fires are left to take care of themselves for nine or ten consecutive hours a little slack or small coal will keep the fire in more safely than coke alone, unless the grate or furnace be a large one, when coke fires answer admirably.

The author has very little to say on the subject of coke crushing machinery, which is generally delicate ground. A very simple roller machine of his own adaptation is found, by the crucial test of experience, to be efficient. It is driven by a portable engine, and, when fully fed, can crush and screen a ton of coke in four minutes. Other machines may do better; but probably it will be considered that this is not bad work. The screened material passes direct into railway trucks, and is ready when loaded for despatch. A vault under the crusher receives the dust falling from the screen. The bare cost of crushing, without interest on plant, works out to 1.73d. per ton during the time the machine is at work.

In works where coke is realizing good value the author would advise the manager to be thankful for his surroundings, and not put down coke crushing machinery, unless perfectly satisfied that an increased return will be the result. Where coke, however, is a drug in the market, even in the colliery districts, crushing it will nearly double its selling price. Much will depend on local circumstances; but, speaking generally, from a knowledge of several works where formerly coke in its large state was unsaleable at a few shillings per ton, reducing its size has increased its value, and enables that value to be maintained during the depression of trade. While the liquid products have suffered such an alarming fall in prices, the residual coke has in all cases remained firm, and in some instances increased in value, notwithstanding, as aforesaid, the prolonged depression in our national prosperity.

The experiences of other managers using bituminous coal will add to the interest attaching to this question. On account of its peculiar nature cannel coke has been omitted from consideration on this occasion; but any experience gained by managers using the better varieties will not be out of place, but fraught with practical value, while a broadcast dissemination of the virtues of gas coke from bituminous coal cannot fail to be productive of beneficial consequences to all interested in the question, be he a scientist, a disciple of Hygeia, a gas manager, or *Paterfamilias* himself.

Discussion.

Mr. H. Hack (Birmingham) said that all must admit the importance of the matter touched upon in these two papers. He would ask Mr. Gandon if he was quite sure of the accuracy of his information about coke being unsuitable for locomotives. He was under the impression that the London and Northwestern and the Midland Railway Companies used coke very largely in their locomotives. In Birmingham they employed it for the locomotives at the gas works, and found it to answer exceedingly well—indeed, better than coal, as it did not stop up the flues so much. Mr. Gandon said that no general principles could be adopted applicable to all places; and all would agree with this statement. Upon one matter, however, he thought all would equally agree, and that was that it did not pay to stack coke in large quantities; that, all things considered, it was advisable to get rid of the coke at such prices as it would fetch, as it was made—for while they were doing all they could to please their customers by breaking coke, etc. (following the plan which had been adopted for many years on the Continent), by stacking it in large quantities they would be undoing much of the good that had been accomplished, because coke deteriorated if stacked for a long time, and if a customer became once dissatisfied through being supplied with old coke, it was a difficult matter to get him to try it again. There could be no

doubt that broken coke was a very suitable fuel for domestic purposes. A short time ago he made some experiments in his own offices in regard to it, trying some of the best gas coal, then broken coke with coal, broken coke with slack, and broken coke by itself, each for 48 hours; thermometers being hung in different parts of the room and on the wall outside the building, and the temperature taken hourly night and day. Taking the difference of temperatures, quantity of fuel used, and all other things into account, the broken coke came out considerably the best.

Mr. W. Sugg (London) said it became his duty some years ago to make inquiries into this question, and, being in Paris, he ascertained what had been accomplished by the Paris Gas Company, who, he believed, had done more than anyone to popularize the burning of coke. The sale for coke there was so large that they had to pile it up in the summer, or they would be unable to supply the large demand in the winter. The principal thing they did at the outset was to study the methods of burning coke in private apartments. They found there were two or three kinds of stoves generally used in Paris, but the one chiefly employed was called the "Prussien," which resembled an English fireplace with the stove taken out, and a shutter in front, which could be lowered to the ground. Inside was a basket in which could be burned either coke or anything else. This answered very well for coke, because when the fire got low the shutter could be lowered, which made a rapid draught underneath, and the coke burnt up. The Paris Gas Company also produced several models of fireplaces, which were still used very satisfactorily; the key to the whole question being the necessity for securing a rapid draught when required. When there was not a blower to pull down the Paris Gas Company used a gauze shutter in front of the fire, so that there was always a draught going in over the front of the fire, and preventing the escape of sulphurous fumes into the room. By such means coke could always be burned well in private apartments, with less of the disagreeable dust which coke burned in an ordinary fireplace generally distributed all over the room, and which was very destructive to furniture. By having this gauze cover over the fire no dust could fall except that which fell to the bottom of the grate, and this could easily be prevented from coming into the room. He had tried coke in his own fireplaces, but he found that, as they were not constructed to burn even coal very well (for in certain positions of the wind the smoke came down the chimney instead of going up), when coke was introduced it was absolutely unbearable. There was no possibility of meeting this difficulty with ordinary fireplaces, and that was a great drawback to the use of coke. But even this might be overcome by the use of a blower, or one of the gauze screens he had described. The main cause of a down-draught was that the chimney throat was too wide, and sometimes it was too large all the way up. In some cases, however, this could be remedied by reducing the aperture at the top, thus preventing the down-draught and the escape of sulphur into the room. Where coke could be sold for domestic purposes—and this brought the best price—it was desirable to ascertain the kind of stoves in use, and then apply some such simple remedy as he had indicated, so that the consumers might be able to use coke advantageously. There was no doubt coke was best for kitcheners, because it kept the flues clear; but for this purpose it must be broken small. If this were done servants would prefer it.

Mr. W. H. Broadberry (Tottenham) said that he had to deal, like Mr. Gandon, with a residential district. At one time they sent the greater portion of their coke away to a distance; but, unfortunately, the representative of a large gas company in the neighborhood found out who was the customer, and business in that quarter dropped off, so that he had to see what he could do to dispose of it for domestic purposes. He commenced breaking the coke by hand, charging an extra price for it; and in the first year he managed to sell about 500 chaldrons in the broken condition. Then he introduced a machine, and the sale increased the next year to 1,200 chaldrons, and the following to 2,800; and he had no doubt it would go on increasing. At first they made a considerable quantity of breeze; but the amount made by the machine was nothing at all in comparison to that made by hand. They had also discovered accidentally that when broken up warm scarcely any breeze at all was made; it did not amount to more than 1½ bushels per ton. They first sold the coke by measure; but breaking it up necessitated selling by weight, and they had experienced no difficulty in making the change. With regard to keeping up the price, they found that doing so only benefited the coke merchant; and therefore they had lowered it at the works, and this, in conjunction with the breaking, was the main cause of the improved demand.

Mr. Lewis (Wellingborough) asked Mr. Gandon whether he included the dust made by the coke breaker in the amount of breeze per ton, which he gave as 1 cwt.; and also whether he experienced any difficulty in disposing of it. He (Mr. Lewis) had at times some trouble in getting

rid of the dust. They had tried it for asphaltting purposes, but people found other material cheaper, because the dust absorbed so large a quantity of tar. They had been breaking coke for about eight years, and had now succeeded in selling 50 per cent. of their make in a broken state. As to the breeze from the coke itself, they used it entirely under the boilers for raising steam. They broke the coke into different sizes for kitcheners and for blacksmiths' purposes. In the winter the latter kind rather accumulated, but it always went off in the summer. He thoroughly endorsed the opinion expressed in both papers as to the wisdom of breaking coke, and thus increasing its sale. He thought it would be wise of every manager to do this; and even those who were well situated at present for getting rid of their coke would materially assist consumers if they were to break it, as it was not altogether a question of £ s. d., but of meeting the customer's requirements in a proper manner, and thus, to a great extent, creating a further demand for coke for domestic and other purposes.

Mr. G. Anderson (London) said the manufacture of breeze into fuel had always been with him purely a commercial question. They had a lot of breeze at a certain gas works for which they formerly got 3s. a ton from the brickmakers; but the price went down by degrees until they were only offered 1s. He then told the manager not to sell it at this price; and as the brickmakers would not give more, he introduced a machine for mixing it with tar, using about 40 gallons to 1 ton of breeze. This did not produce a smoky fuel; on the contrary, it required some stirring to make it burn. It did not fall to pieces, but retained its shape. When the brickmakers saw what they were doing they bought the breeze at the old price. He therefore stopped the machine, because they had a bad sale for coke, and he did not want to make coke artificially. It was simply a commercial question with him, and he should not have introduced the machine at all if he could have sold the breeze.

Mr. Wilkinson (Harrogate) said his was a purely residential neighborhood, and for many years they had had an annual accumulation of coke, amounting sometimes to 900 or 1,000 tons. They used a good caking coal, containing very little sulphur; and from the coke produced after firing the furnaces, they had something like 12 cwt. per ton of coal carbonized for actual sale, which realized about 11s. 6d. per ton. By the use of a coke breaker the whole was now readily disposed of. They utilized the breeze and also their clinkers for making asphalt, which was sold for making paths. They also used the breeze, mixed with lime, for building purposes, putting in about a quart of tar to each pug-mill panful, and intimately mixing. This made a mortar which was almost as good as cement. If a cartload were made on Saturday, it would take a pickax to separate it on Monday. The small coke breeze, when all which could be otherwise utilized had been picked out of it, was spread over the coal before putting it in the retort; so that they got it back again in the shape of coke, and without at all deteriorating the sample of coke or gas. With reference to the calorific value of coke, he might say that they had to use road steamers and wagons to fetch their coal; and during the Jubilee celebration they volunteered to take about 500 children in their coal wagons in the procession. The train consisted of one 8-horse power road engine and five large wagons gaily decorated. They only used broken coke for firing, had neither smoke nor dust, and took a load of 40 or 50 tons very easily up some steep gradients—as much as 1 in 13. The pressure in the boiler was easily maintained at from 150 to 160 lbs. when required.

Mr. F. D. Marshall (Copenhagen) said he had about a dozen coke crushers, and his difficulty was to get a material which would stand the wear and tear. He had tried teeth on rollers, toothed rollers, plain rollers, cast iron, wrought iron and malleable iron; but until lately had never been able to get a tooth which would stand the heavy work. After about a week the rollers failed and the teeth had to be replaced. Recently he had obtained some Swedish cast iron, which seemed absolutely indestructible. It had been in use now for three or four months, and showed no signs of wear. This was a very important matter, as the cost of a set of teeth was from £1 to £2. He should like to know what material Mr. Gandon used.

Mr. Fish (London) was about to refer to some of the historical points brought out in Mr. Jones' paper, when

The President suggested that, though ancient history was very interesting, the time at the disposal of the meeting would hardly allow of their going so far back.

Mr. Gandon (Sydenham) said he had noticed one or two points in which Mr. Jones did not quite agree with him—for example, in the cost of crushing, which Mr. Jones put at 1.73d., whereas he gave it at 10d. per ton; and naturally people might think the evidence conflicting. All he could say was that he had his coke broken by contract, and that was what he paid; and the contractors were not getting very rich upon it.

Whether Mr. Jones had a superior machine, or a superior kind of laborer, he did not know. Then Mr. Jones said that where the coke realized a good price he would not recommend it being broken; but he (Mr. Gandon) could not agree with that. Where they obtained a good price for unbroken coke they might get a still better price for broken; at any rate it was worth trying. Mr. Jones also said that while the liquid products had suffered great depression, coke had remained firm, and in some cases had increased in value. This was true; but many could bear testimony that in other instances it had declined. When he spoke of the use of coke in locomotives he referred only to gas coke, and that was not an absolute rule, because they had a small locomotive at his works in which they employed coke. So far as he knew, however, railway engines used a specially-made coke; he had never known them to burn gas coke for long journeys or heavy loads. Mr. Sugg's remarks were very useful as to the necessity of producing a quick draught when fresh coke was put on in domestic fireplaces. In answer to Mr. Lewis' question he would say that the breaking caused 1 cwt. of breeze, besides what there would be were the coke sold unbroken. With regard to the crusher teeth, he used discs, $\frac{1}{4}$ -inch thick, mounted on a shaft with distance pieces between them, and the discs could be taken off and new ones fixed. He agreed with Mr. Marshall as to this difficulty; in fact it was the only difficulty he had with the breaker. If Mr. Marshall had some material which did not wear out he should feel very grateful for some samples. He had tried wrought iron, cast iron, Swedish iron and steel; but the cheapest he had found, which were at all good, were made of malleable cast steel, costing about 3s. each. He had excellent ones made of some kind of steel at 6s. each; but this was rather too dear. He was practically satisfied with the cheaper ones, and found that they lasted about six months, the sets on each roller being replaced alternately, at intervals of three months.

The President said these were two very practical papers on a very practical subject. In the north they had a different quality of coal to deal with, and the coke produced was unsuited for domestic purposes. Still they managed in Glasgow to sell about 80,000 tons a year, by far the larger portion of which went for a purpose for which it would not at first sight appear very suitable—viz., for use in smelting furnaces. Of course, they only obtained a low price. He thought the best means which could be adopted for developing the sale of coke for domestic purposes was to pay more attention to the stoves and fireplaces in which it was burned; for it was the difficulty of burning it more than anything else that prevented its more general use. He knew the fires to which Mr. Sugg had referred in Paris. They were very cheap and efficient; and he did not know why they could not be introduced here. Why should not gas companies sell them or hire them out, as they did gas stoves for cooking and heating?

Test of Refrigerating Apparatus.

The approaches to the great bridge which spans the East River are immense structures of masonry, and these arches or vaults have been utilized in a sensible manner by closing them at either side and converting the rooms thus formed into cold storage warehouses, for the purpose of keeping articles which would be perishable at the natural temperature. This system of refrigeration is based upon the volatilization of anhydrous ammonia, and the heat absorbed in this evaporation of the ammonia chills a solution of chloride of calcium, which circulates through pipes in the warehouse, and reduces the temperature by direct absorption of the heat radiated toward the pipes.

These refrigerating machines were installed under a contract guaranteeing that each one should have the capacity of absorbing, every 24 hours, a quantity of heat sufficient to melt 40,000 lbs. of ice. The question of their conformity to the specifications was referred to Messrs. Collingwood, Martin, and Abbott, all members of the American Society of Civil Engineers, and they found that each machine possessed a refrigerating capacity equivalent to the melting capacity of 43,595 lbs. of ice, or 9 per cent. in excess of the contract.

The weight of the solution used was 73.48 lbs. per cubic foot, or 1.16314 specific gravity, and its specific heat was found by experiment to be .827. The brine was measured by a water meter, and differences in temperature indicated by a thermometer. They avoided a frequent and inexcusable error by ascertaining the specific heat of the solution by actual experiment, instead of assuming it to be unity. There is no statement made relative to the kind of thermometer used, but for low temperatures alcohol would be superior to mercury thermometers.

The efficiency of the apparatus for 24 hours was found by adding the products of the cubic feet of brine circulating through the pipes by the corresponding differences in temperature in the ingoing and outgoing

currents of brine as observed at frequent intervals, and this sum was multiplied by the specific heat of the brine (.827) and its weight per cubic foot (73.48), and the final product—applying all allowances for corrections from various sources—amounted to 6,218,816 heat units as the amount abstracted in 24 hours.

According to the determination made by Dessains and De la Provostaye, 142.65 British thermal units are necessary to melt 1 lb. of ice; and therefore this apparatus has a refrigerating capacity equivalent to that produced by 43,565 lbs. of ice in 24 hours. This result was accomplished by the combustion of 2,000 lbs. of coal under the boiler operating the pump condensing the anhydrous ammonia vapor. If this coal possessed a theoretical calorific value of 13,500 heat units per pound, the total amount of energy of combustion in 24 hours would be $2,000 \times 13,500 = 27,000,000$ heat units, and the result of the process of transformation of energy was, as already stated, 6,218,816 heat units, showing an efficiency of 23 per cent., which is certainly very high in comparison with other methods of transformation of energy in connection with prime movers; and it is safe to assume that it would be practicable to increase this ratio of efficiency with a plant on a larger scale.

Humphrys' Patent Damper Frame for Furnaces.

Our versatile and accomplished English correspondent would seem to be a tolerably busy man, judging from the fact that he is Engineer to the Salisbury Gas Company (which sends out about 70 millions cubic feet of gas per annum), is a frequent contributor to the English technical journals, and is often called upon to give his fellows the benefit of his judgment and experience in the matter of experiments, analyses, and the like. However, the multiplicity of his avocations does not appear to have prevented him from taking a hand in the field of invention, in proof whereof we submit the following description (reprinted from a late issue of the *London Journal*) of a patent damper frame for furnaces, which he has recently placed on the English market. Our authority says:

The increased attention that has of late been directed to the combustion of fuel, with a view of securing the full heating power of the material, and also the avoidance of smoke, has created a demand for a better and more delicate method of adjusting the area of the opening controlled by the damper than the various rough-and-ready plans that are at present generally adopted. Especially in the case of furnaces on the generator system is a delicate adjustment of the damper area, both in respect to the air supply and to the products of combustion, of importance. And whether it be for the generation of steam, for heating retorts at gas works, or, in short, for any kind of furnace, the advantage gained by being able to accurately adjust the damper goes without saying. Mr. Norton H. Humphrys, of Salisbury, having experienced a difficulty in obtaining an accurate adjustment of dampers in the retort house, especially in connection with closing them during 12 hours' stoppage on Sundays, has directed his attention to overcoming the same, and the result is the invention we are about to describe.

One of the first conditions ascertained was that, in order to secure thoroughly satisfactory results, the regulating apparatus must be as close as possible to the damper itself; as all devices comprising chains passing over pulleys and carried to the front of the furnace, and such like, are unreliable for practical working. The chains are apt to expand and contract according to the variations in temperature to which they may be exposed, and also to stretch slightly under the constant tension to which they are subjected. Since a variation of only $\frac{1}{4}$ inch may lead to erroneous results—and such a variation may readily occur over a length of 40 to 50 feet of chain—it is obviously impossible to secure, under such conditions, the accurate adjustment that is indispensable for modern kinds of furnaces. It is claimed that the arrangement now under notice will admit of delicate and reliable regulation, so that, if desired, the damper may be closed entirely, and subsequently replaced with absolute certainty in exactly the original position, by a momentary operation, capable of being performed by an ordinary laborer, and in the dark if necessary; also that it is simple in construction and easily made, being free from screws or other mechanical parts likely to get out of order or be interfered with by dust or dirt.

The salient features of the invention (which is made in several modifications, to suit the size and position of the dampers for which it is to be used) are a frame for receiving the portion of the damper drawn out of the flue, a graduated bar, perforated at suitable intervals either with slots or round holes, a handle, an adjustable connecting link, and a linch-pin. These may all be in separate parts, connected together by bolts and nuts, or in any convenient manner, or any two or more may be joined in one

piece, according to requirements, the size of the damper, and the direction of travel; and the various modifications admit and include the fixing of the frame above, below, or on either side of a horizontal flue or a vertical flue, and, of course, are equally applicable to flues inclined at any angle. The specification also includes the use of guide rollers and counterpoise weights, the enclosure of the arrangement completely, by adding plates on each side of the frame, and adapting a lock or padlock so as to secure the damper from being tampered with by unauthorized persons. The frame may be of cast or wrought iron, as preferred, and the other parts of wrought iron. In width the frame is made rather more than the thickness of the damper, so as to protect it from accidental injury. The measurements on the bar may be simply lineal, or may show the area of the opening left by the damper.

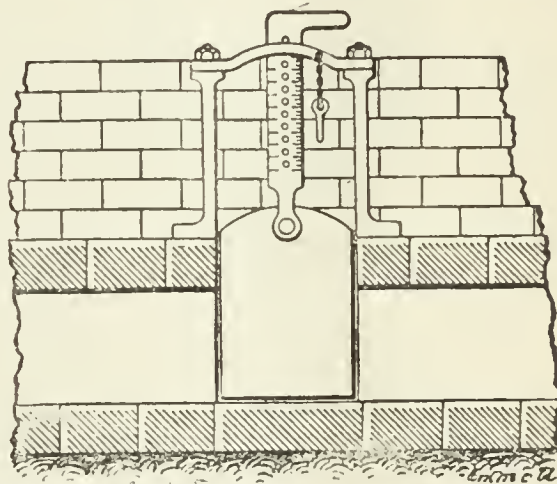
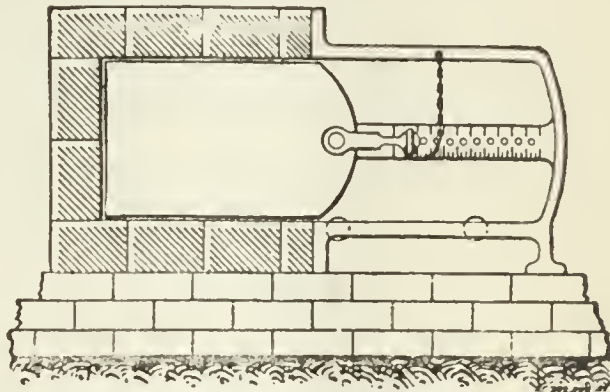

Humphrys' Patent Damper Frame for Furnaces.

The engravings show two forms of applying the arrangement—fig. 1 being suitable for a horizontal, and fig. 2 for a vertical travel of the damper. In the former the graduated bar may be cast in one piece with the frame, or attached to it; and the handle is fixed to the link, which also carries a perforation corresponding to those on the bar. The frame, with the linch pin connected to it by a loose chain in a convenient position, having been fixed, the damper is placed in position, and the adjustable link with handle connected thereto. The damper being close home, the link is adjusted so as to make the perforation in it exactly register with that representing the zero mark on the bar, when the linch-pin will engage with both holes. In this position the damper is closed and maintained so. Let us now suppose that the damper is to be opened to the extent of 6 inches, which with a 12-inch damper would give an area of 72 square inches. The pin is removed, the damper drawn out by means of the handle until the perforation on the link registers with that corresponding to 6 inches or 72 square inches on the scale, and the pin again inserted and fastened with a padlock if desired. In like manner other widths of opening may be obtained, the scale and number of perforations being adapted to the width of the flue and the degree of delicacy of adjustment required.

Fig. 2 shows a simple and cheap modification for rough work, The frame is made in three pieces, and the perforated bar and link in one piece. The uprights having been secured to the brickwork by projecting tongues which are built in, the damper is placed in position as closed, and the link and bar affixed. The bridge-piece, which has a slot for the bar to travel in, is then put on, and so adjusted by introducing washers on the threads which receive it at the top of the upright pieces that the hole corresponding to the zero mark is just capable of receiving the linch-pin above the bridge-piece. The handle is then attached to the top of the bar. The manner of working will be obvious from the description of the other arrangement. The handle is grasped with one hand, and the pin removed with the other. The damper is then pulled up until the perforation corresponding to the desired extent of opening comes above the slot,

when the pin is inserted, and serves to support the whole arrangement.

In fig. 2 the device is shown as applied to one of a series of furnaces, opening into a bottom main flue situated immediately behind them.

Richard Brothers' Standard Gas Gauges.

M. Jouanne, writing in a late issue of *Le Gaz*, calls attention to the fact that the glass tubes or gauges generally used in gas works present certain inconveniences well known to gas men, especially with reference to reading the two columns, ordinarily out of level, and usually covered with a greasy film, which makes its appearance with surprising quickness. The latter condition, of course, necessitates a frequent dismounting of the tubes so that they may be cleaned. Now, that is not always an agreeable operation, and under any and all circumstances constitutes one of the petty annoyances of the gas maker's trade, which albeit of no very vital importance, is nevertheless one of those things that it would be well to get rid of.

In furthering the attempt to dissipate that annoyance he thinks it may interest the readers of *Le Gaz* to hear that an instrument to do away



Fig. 1.—DIAL-PLATE GAUGE FOR DETERMINING GAS PRESSURES AND CHIMNEY DRAUGHTS.

with the vexatious glass tubes, and at the same time present an arrangement as practical and as agreeable as any of the dial-plate gauges employed to register high pressures, has been placed on the market.

This apparatus, constructed by the Messrs. Richard Brothers, is, to all intents and purposes, a small dial-plate gauge. It is very sensitive, quite easy to read, and easily portable. It can not only be used as a stationary gauge, but may also be employed to determine the pressure existing in

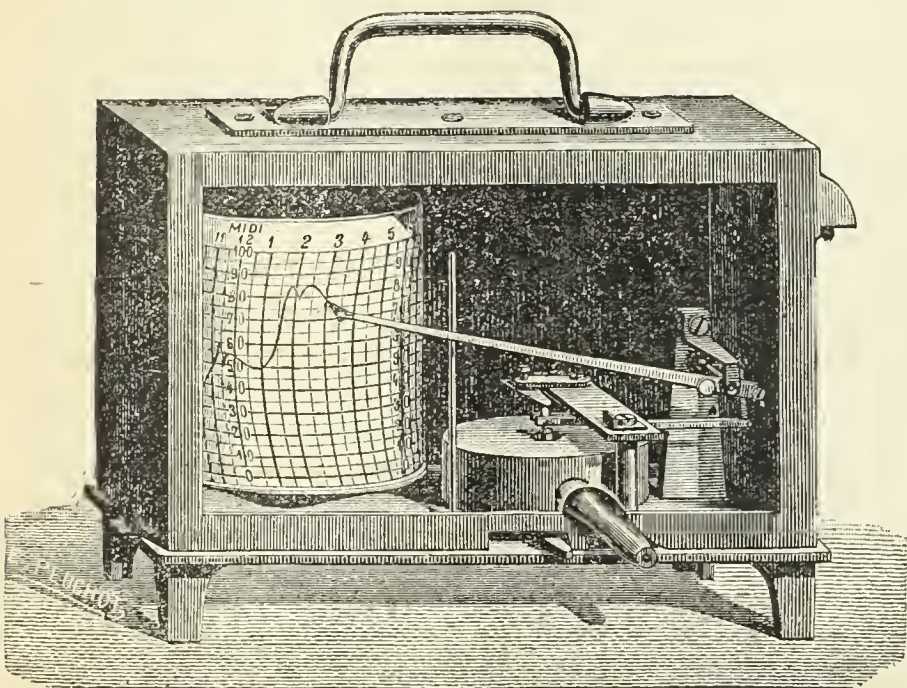

Fig. 2.—GAUGE REGISTER FOR GAS WORKS.

main. Further, it is sensitive enough to measure the draughts in chimneys and flues.

Figure 1, which gives a front view of the instrument, renders unnecessary any detailed description of the arrangement of the parts. The pressure of the gas exerted on a very sensitive flexible membrane puts the indicating needle in play in a manner analogous to the working of high pressure gauges.

The Messrs. Richard Brothers have brought out still another apparatus which recommends itself to the favorable attention of the managers of gas works. This device is a registering gauge capable of indicating the smallest pressure and vacuum, and consequently permitting the examiner to observe and note correctly the variations of pressure at different parts of a main, the draught in the benches of retorts, etc.

Figure 2 shows the mechanism of the apparatus. The gas enters, by means of a rubber pipe, in the small cylinder fastened to the bottom of a rectangular box, and actuates a flexible membrane, whose movements of depression or elevation put in play a jointed lever that carries, at its extreme end, the pen which traces the diagram on a sheet of paper that is rolled conveniently around a drum. The rotation of the drum is produced by means of a clockwork mechanism, as in ordinary pressure indicators, and in the greater number of known registering apparatus. This gauge, being small in size and easily carried, seems to us likely to be of great assistance on many occasions.

ITEMS OF INTEREST FROM VARIOUS LOCALITIES.

WORK IN PROGRESS AT LA CROSSE, WIS.—Mr. Geo. McMillan, Superintendent of the La Crosse Gas Light Company, cannot have had many idle days this summer, for he has been kept quite busy directing the movements of the workmen engaged in perfecting the plant improvements mapped out by the Company last spring. The principal items in the list of betterments include a telescopic holder, and an extensive addition to the purifying system, which latter extension guarantees an ability to pass 400,000 cubic feet per diem through the boxes. While the Company's sendout has not yet reached that maximum, Mr. McMillan reports that, in consequence of the greatly extended use of gas stoves in La Crosse, he believes the purifying system will at no distant day be no more than adequate for the Company's needs. The holder now in process of construction is to have a capacity of 140,000 cubic feet, and it will be of immense value to the Company, for the La Crosse folks have been working pretty close to the wind in the matter of storage facilities. The ground in which the tank was sunk proved to be of the solid sort, although it was found necessary to put in some timberwork on the bottom. The tank wall, of brick, is 36 inches at the base, diminishing to 26 inches at the top, and rests on a solid foundation of concrete. It is estimated that the entire cost of the holder and tank will be in the neighborhood of \$16,500, and that sum, we presume, will have been about doubled when the purifying plant extensions and other general betterments are paid for. Perhaps it is just as well that Bro. McMillan's vacation was curtailed, because the work that necessitated his "sticking to business" this summer will furnish a recompense, in the shape of guaranteeing to him a mind at ease during the dark hours of the coming winter.

ELECTRIC LIGHT AT KINGSTON, CANADA.—We understand that all the plant requisite for lighting the city of Kingston by electricity has been purchased, and that the work of erecting the same is now in progress.

TURNED ON AT QUEBEC, CANADA.—While Kingston anticipates the coming of the light of the future, Quebec now basks in the full glow of the sparkle from betwixt the carbon points, the current having been turned on about a fortnight ago. The new departure was inaugurated with music and "cheers," and several hundred people gathered about the musicians, who were appropriately grouped or perched in eligible situations on Dufferin Terrace, ushered in the electric illuminant to the strains of, "See, the conquering hero," etc. The power that operates the Quebec electric light plant is derived from the Falls of Montmorenci.

TO BE LIGHTED BY GAS.—We understand that responsible parties are negotiating for the right to operate a gas works in Marysville, Ohio, with every prospect that their demands will be acceded to. Marysville is the capital of Union county, Ohio, and is located in Paris township. Mill Creek runs through the place, as also does the railroad which connects Delaware with Springfield. It is 17 miles west-southwest of Delaware, and 28 miles northwest of Columbus. Marysville gives promise of becoming an important business center. In fact it may be said to have achieved considerable prominence already, since it contains a good court house building, 4 banks, 5 churches, and a grammar school, and supports two newspapers. An extensive growth of hard wood surrounds the place, and that material gives work to a large number of persons who are employed in the manufacture of butter tubs, wagon spokes, etc. Population about 4,500.

LIKELY TO BE CONSOLIDATED.—Rumor has it that the owners of the New Bedford (Mass.) Gas Light Company have instituted negotiations

looking to the purchase of the local electric lighting company's franchise. [The purchase has been made.]

DIVIDEND DECLARED.—At a meeting of the Directors of the Vicksburg (Miss.) Gas Light Company, held during the last week of July, a dividend of 2½ per cent. was declared out of the earnings for the last six months. The Company seems to be in fairly prosperous condition, although much yet remains to be accomplished in the matter of plant betterment. That remark applies, perhaps, more particularly to conduit improvements.

IMPORTANT PATENT LITIGATION.—According to late advices it seems that Dr. Otto, of Germany, the inventor and patentee of the justly celebrated gas engine bearing his name, has commenced an action in the United States Court, Southern District of New York, for an injunction and heavy damages, against parties making and using the motor known as the Korting gas engine. Among those impleaded as defendants we note the names of Messrs. Adolph Witteman, Geo. F. Sturken, Jno. C. Seaman and Melville C. Thwing, all of this city. Dr. Otto is in earnest about the present suit, and the trial developments ought to furnish interesting reading to the gas fraternity of this country.

DEATH OF THE PRESIDENT OF THE DAVENPORT (IOWA) GAS COMPANY.—We regret exceedingly to have to announce the death of Mr. C. E. Putnam, late President of the Davenport Gas Light Company. Beyond this meager statement we are at present unable to go, but hope at some future time to place before our readers a few facts connected with his busy life.

BAPTIZED ANEW.—Brother Norton and his associates, seemingly not satisfied with the scope of their former line of action, and having obtained the necessary legislative consent, have decided that the old Nashua Gas Light Company, *per se*, is a thing of the past—as far as its former corporate title is concerned. The present corporate title is that of the "Nashua Heat and Power Company," and the capital stock is limited to \$200,000. The old-new Company now has the right to supply any and all sorts of artificial light. May its future in the new order of things be as prosperous as was that of its past.

IMPROVEMENTS AT ADAMS, MASS.—The owners of the Adams Gas Light Company are extending their delivery system. The principal addition consists of a new 6-inch main, in Park street, that is to terminate at the junction of Commercial and Center streets.

A QUEER CASE.—According to Newark (N. J.) advices, the case of Alden vs. the Citizens Gas Light Company of that city, which case has been in litigation for something like 20 years, was recently revived on a motion made by R. Wayne Parker, counsel for the plaintiff, for the correction of a verdict. It seems that the Gas Company took the property on which its plant is now located subject to the dower interest of Mrs. Alden, and subsequently became mortgagor in possession through the assignment of a mortgage for \$1,800. Tax titles and other complex questions were disposed of, and, as the dower could not well be assigned without injury to the works, in 1878 a sheriff's inquiry resulted in a verdict fixing the widow's annual income interest in the property. To this was to be added interest for eight years, and Mr. Parker claimed that, instead of calculating the interest on each item for 8, 7, 6, etc., years respectively, interest had been calculated on but one item, and multiplied by 8. The Gas Company, by Thos. N. McCarter, contended that the verdict, after the end of the term of Court when it was returned, could neither be altered nor corrected, and the Court held that Mr. McCarter's argument or view was correct.

ONE RESULT OF THE BROOKLYN (N. Y.) GAS RATE.—In 1886 the assessment rolls for the city of Brooklyn showed that the gas companies of the city were assessed, in the item of stock values as a basis for personal property taxation purposes, at a total of \$4,135,500, whereas the corresponding return for the current year shows the valuation to have been put at \$3,323,400, or a decrease of \$812,100. The Brooklyn *Daily Eagle*, in commenting on the above fact, says: "The difference (\$812,000) represents the depreciation in value of gas stock during the past twelve months, occasioned largely by the recently enacted law of Senator Griswold, reducing the price of gas in this city from \$2 to \$1.60 per thousand cubic feet, but due in a measure also to the competition of electric lights."

THE WATERHOUSE ELECTRIC LIGHTING SYSTEM.—The proprietors of the Willimantic (Conn.) Electric Light Company, who operate under the Waterhouse system, have recently increased their plant, and are

now supplying both arc and incandescent lights (taken from the same circuit) to their customers.

THE ANNUAL REPORT, ENGLISH PATENT OFFICE.—The Report of the Comptroller of the English Patent Office, for the year 1886, has been presented to Parliament. From it we learn that the numbers of applications for patents for the three years during which the last Patent Act has been in force are as follows: 1884, 17,100; 1885, 16,101; 1886, 17,162; 14,822 of the '86 applications were accompanied by provisional specifications, and 2,340 by complete ones. Of the applications for the year 1885, 54 per cent. were proceeded with, as compared with 58 per cent. of those of 1884. Up to the present date no applications have been received for the granting of compulsory licenses, a provision permitting such applications having been introduced for the first time into the Patent Act of 1883. Only three volumes of abridgements, and all of those in continuation of former series, have been issued during the year. The report fails to mention what progress has been made with the new subject-matter indexes, which, according to statements uttered before the Departmental Committee of the Patent Office, were shortly to be issued. The total receipts of the office during the year amounted to \$534,770, the payments amounting to \$547,835, leaving a deficit of \$13,065. This deficit, however, is really only an apparent one, because the whole cost of the purchase of certain new offices, amounting to \$131,760, is charged to the year under review. 23,717 designs and 324 sets of designs were registered during the year. The total number of applications for trademarks was 10,677.

NEW PUBLIC WORKS AT CANTON, DAK. TER.—The Canton Improvement Company has asked the local council for an exclusive franchise to construct and operate water, gas, and electric light works within the town limits. The applicants agree to supply the authorities with 16 fire hydrants for town purposes, provided an annual total rental of \$800 is paid for the same. The petition is likely to be acted on favorably. Canton is the capital seat of Lincoln county, Dak.; is on the Big Sioux river, at a point opposite Beloit, Iowa; and is 41 miles west-northwest of Sheldon, Iowa. It is growing with amazing rapidity.

GASEOUS DOINGS AT DES MOINES, IOWA.—Brother Pratt, the former Superintendent of the North Attleboro (Mass.) Gas Light Company, but now in charge of the Capital City Gas Light Company, of Des Moines, Iowa, is "doing quite well" in his new field of action. An auxiliary water gas plant has been added to the Capital City works, and, as we understand it, an illuminating product composed of one-third water gas and two-thirds coal gas is now being sent out from the works. The Des Moines *Register* asserts that \$40,000 have been expended in perfecting the Capital City Company's manufacturing plant.

CAPITAL INCREASED.—From a certificate filed with the Albany (N. Y.) authorities, we learn that the capital stock of the Salamanca Gas Company has been increased to \$60,000. Former capital, \$30,000.

TO SUPPLY ELECTRIC LIGHT.—The proprietors of the Rome (N. Y.) Gas Light Company have petitioned the City Council for an amendment to their charter which will permit them to furnish incandescent electric lights for domestic lighting.

AT WORK ON THE STATION.—The contractors are busily engaged in carrying on the work of constructing the Brush electric light station at Geneva, N. Y. The plans call for the erection of a building 40 ft. in width by 100 ft. in depth, the skeleton to be of wood, with a covering of corrugated iron.

IN REGARD TO THE SALE OF THE ONEIDA (N. Y.) GAS LIGHT COMPANY.—A recent issue of the Utica *Herald* contained the following: "A current rumor, which appears to have much foundation on fact, is to the effect that the Oneida Gas Company has sold its plant and franchise to parties from New York and Rhode Island. It is asserted by some that the sale is in the interest of the American Electric Light Company, and that in fact the contract is complete for the sale and transfer. This, however, is not substantiated by the Gas Company, the President of which says that parties from New York and Providence have been negotiating for the purchase of the plant, and that while the contract is not yet complete, the indications are that the deal will undoubtedly be consummated. There are certain conditions yet to be fulfilled before the contract could be said to be closed. A clear majority of the stock must be transferred, and the President was busy interviewing the stockholders in an attempt to gain the assent of a majority to the sale. The officers will see every stockholder, so as to give each of them an opportunity to dispose of his holdings. The President also said that the parties negotiating for the

plant are others than the American Electric Light Company. The presence in town of a couple of the officers of that Company led to the belief that they were the parties who were after the gas plant. In the event of the transfer being completed, possession will not be given until Sept. 1, when the former proprietors of the Oneida Gas Light Company will step down and out."

PROPOSED NEW GAS COMPANY.—Martinez (Cal.) is to have a gas works. This place is the capital seat of Contra Costa county, and is on the south shore of Suisun Bay, at the east end of the Strait of Carquinez. It is some 36 miles (by water) northeast of San Francisco, and 3 miles south of Benecia. The climate is very even, and the soil is quite fertile.

TO BUILD A NEW STATION METER.—The American Meter Company is under contract to construct a station meter to the order of the Utica (N. Y.) Electric and Gas Company. It will be finished in ample time to register the coming winter's output.

LOWELL'S NEW HOLDER.—The Lowell (Mass.) Gas Light Company's new holder is well underway. In fact it is expected that Oct. 1st will find it in working duty. Its capacity is rated at 750,000 cubic feet, and the Lowell *Citizen* calmly predicts that, owing to the increased storage facilities thus created, the Gas Company will probably be enabled pretty soon "to reduce its selling rate to \$1 per thousand cubic feet." We hope so; but Bro. Cushing is the one to speak with authority about such things.

SUIT AGAINST THE COUNTY OF GALVESTON, TEXAS.—The cases of the Galveston Gas Company and the Galveston Wharf Company vs. the county of Galveston came up for hearing on July 25th, in the Galveston District Court, after having remained in abeyance for some time. These suits were originally instituted against the county in the year 1876, the plaintiffs alleging as a cause for action that the authorities had imposed an illegal assessment upon them, and the suits were brought with a view to compel the county to return the moneys paid under the alleged wrongfully imposed assessment of 1876. Each plaintiff contended that, in the year cited, it had been assessed considerably in excess of the actual valuation of the property, and sought reimbursement. The case of the Galveston Gas Company was primarily heard in the District Court, at which time it was agreed that the Wharf Company should accept the decree rendered in the trial case. The first hearing was decided in favor of the county; but an appeal from the ruling, argued in the Supreme Court, resulted in a reversal of the judgment of the lower court, and a remanding of the case back to the District Court. It seems that the county is likely to be worsted this time. The amount at stake in the case of the Gas Company is \$1,949.60, which, with interest for 11 years, would make a very acceptable addition to its treasury.

BROTHER DENNISTON AT IT AGAIN.—The following announcement has recently been made to the gas consumers on the roster of the East End Gas Company, Pittsburgh, Pa.: "On and after Oct. 1, 1887, the price of illuminating gas will be as follows—prompt payment to be observed in all instances:

Monthly Consumption.	Net Rate.
8,000 cu. ft. or over.....	\$1.00
5,000 "	1.12½
2,500 "	1.20
Less than 1,000 cu. ft.	1.30"

Now, we submit that this is evidence of Brother Denniston's good intentions, and we expect that he will soon have to add more Critchlow-McKay machines to the present East End plant. The \$ mark keeps cropping out; and often may it do so.

OIL CITY (PA.) GAS RATES.—The proprietors of the Oil City Gas Company have determined upon the following selling rates, as per notice given during the last week in July: The following rates will be charged for gas (natural) for illuminating purposes, from and after Aug. 1—

Nature of Service.	Per Month.
One jet.....	\$0.20
Two or more jets, each.....	.15
Siemens lamp, small.....	.50
" " large75
Lungren lamp, small40
" " large.....	.50
Street torches, ½ opening	1.00

STREET LIGHTING AT BELLEVILLE, ILLS.—It is reported that the St. Clair Steam Supply and Electric Light Company will light the streets of Belleville for the next three years. By the proposals submitted the Com-

pany offered to maintain 75 arc lamps at an annual charge of \$125 each, but if 100 (or over) lights were to be maintained, each lamp would be supplied at an annual charge of \$120. We cannot say which proposal was accepted.

PUBLIC LIGHTING AT DETROIT, MICH.—The Aldermanic Board some time ago decided to accept the terms of the bid for public lighting submitted by the Brush Company, and the matter was then forwarded to the Mayor for final sanction—the Brush Company was awarded the contract for a three-year term. It was not supposed that the Mayor would offer any objection to the decision of the Board, but a correspondent informs us that "The most prominent feature of the Aldermanic session held Aug. 3 was the reception of a communication from the Mayor by which that official vetoed the three-years public lighting contract with the Brush Electric Light Company. The Mayor, in explanation of his adverse action, said that a three-years contract would result in but trifling advantage to the city, because the rebate or shrinkage on the payment really figured out only \$15,900, were the three-year contract to prevail instead of accepting the Company's offer for one year. If the long-term policy were to be agreed to the city would be shut out from all benefit that might accrue from advances made in the generation and distribution of electric light during the life of the contract. The Mayor further said that lighting by gas was being rapidly improved and cheapened, and that it would be unwise to shut the city out from any possible benefit in such direction by entering into a long-term contract with the Brush Company. The Mayor also mentioned the fact that the Brush Company had ignored the ordinance requiring it to place its wires underground." Detroit evidently is ruled by a Mayor whose action is founded on common sense, and who also has the courage to "speak right out in meetin'." The veto message commanded close attention, and was not without effect on some of the "long termers," although Ald. Burt, who we believe is a firm believer in arc lighting in general, and a decided advocate of the Brush system in particular, immediately seized the bull by the horns in offering a motion "that the resolution authorizing the City Controller to contract with the Brush Company for three years be passed, notwithstanding the veto of the Mayor." Others of the long termers, seemingly disposed to deal tenderly with the aforesaid "horns," suggested that Ald. Burt's motion indicated undue haste. This idea found favor with the majority, and a motion to table the matter prevailed. In the meantime it looks to us as if the Detroit Aldermen (or at least some members of that body) were dangling somewhere between the devil and the deep sea. In either event the danglers are not on very solid footing, especially since it is unlikely that they are either salamandrine or web-footed.

MESSRS. P. H. & F. M. ROOTS PREPARING FOR A BUSY SEASON.—The Messrs. P. H. & F. M. Roots, of Connersville, Ind., in order to keep pace with the demands made upon them for their well-known specialties, have found it necessary to make large additions to their buildings. When these improvements have been completed (the scheme of betterment will involve an expenditure of about \$18,000) the Company will have as complete facilities for filling orders and turning out work as any other manufacturing establishment in the country. The Messrs. Roots have just issued their new gas exhauster catalogue, a copy of which will be mailed to anyone who addresses them at their headquarters in Connersville, Ind.

PERSONAL.—Mr. A. B. Stannard, although somewhat browned by travel, is as brisk and alert as ever. He tried the celebrated Hoyt estate elevator, which has done duty for several years in numerous Pine street mansions (of course, No. 42 is one of these), and although inclined to complain about the principle on which the said elevator is constructed, he had "breath" enough left to say that the tan on his cheeks was caused by the necessity which obliged him to be constantly on the road as a trusted Special Agent of the American Water Works and Guarantee Company, whose headquarters are at present in Muncie, Ind. We understand, however, that the Company, owing to the many and extensive franchises now controlled by it, will shortly locate in one of the largest cities in the West. The Company is a sterling concern, and in Special Agent Stannard it has secured a bright and energetic attache. May good luck follow him in his travels.

NEW GAS COMPANY.—Responsible parties have determined to organize a gas company in the town of North La Crosse, Wis. Why this step should be taken we fail to understand, for it would seem as if the La Crosse Gas Light Company (if we mistake not, North La Crosse is really a ward of the city of La Crosse) was quite equal to the duty of furnishing all the illuminating gas needed in that locality. Perhaps Supt. McMillan,

of the old La Crosse gas plant, would post us in respect to the proposed new company.

AND YET ANOTHER.—Pomona, Cal., is to have a gas company—this, we think, is the seventh gas company that has been proposed in the Golden State during the present year. Pomona is in Los Angeles county, Cal., and is on the Yuma division of the Southern Pacific Railroad. It is 33 miles east of Los Angeles.

MESSRS. R. & J. DEMPSTER TO DO THE WORK.—Some time ago we noted that Messrs. C. & W. Walker, of London, England, were to build a holder (1,200,000 cubic feet capacity) to the order of the Toronto (Can.) Gas Light Company. We can supplement that statement by saying that the Messrs. R. & J. Dempster, of Manchester, England, have received an order from the Toronto Company for a wrought iron roof for a retort house now in process of erection. The house has a dimension of 302 feet by 76 feet, and the Messrs. Dempster have agreed to deliver and fix the roof within a period of 16 weeks from the date of signing the contract.

A WORD OR TWO FROM WHEELING, WEST VA.—It has been determined to add a Pelouze and Audouin condenser to the plant of the Wheeling gas works. Mr. Jas. Dyson, who has for some years most creditably filled the position of City Gas Inspector at Wheeling, has resigned in order to accept a similar office in the service of the Natural Gas Company, of West Virginia.

INTERESTING FIGURES.—We are indebted to Mr. Charles Nickson, Supt. of the Manchester (England) Corporation Gas Works, for a copy of the "abstract of the accounts" of that huge undertaking for the year ended March 31, 1887. From this source we learn that the total quantity of coal (including cannel) carbonized during the year was 292,335 tons, which produced 3,021,682,000 cubic feet of gas, or an average of 10,336 cubic feet per ton of coal carbonized. The quantity of gas transmitted from the works, in comparison with that sent out last year, shows an increase of 4.47 per cent.; but the quantity measured and accounted for shows a gain of 6 per cent., which latter is largely attributable to the fact that the loss from leakage and condensation (1887) was 6.34 per cent., as compared with 7.69 per cent. for 1886. The illuminating power of the gas averaged (mean of 4 daily readings) 19.44 candles, and was fully equal to legal requirement in respect of freedom from impurities. The largest quantity of gas ever consumed in Manchester in one day occurred on December 30, 1886, when 19 millions cubic feet passed through the station meters. During the week ended December 23, 1886, the consumption reached a total of 107,291,000 cubic feet. The number of gas cookers, heaters, etc., out on hire on March 31, 1887, was 1,609, or an increase of 165 as compared with the previous year. The capital invested in these appliances is £4,534, and the amount received for hire was £521. The estimated quantity of gas consumed by the stoves is 14,207,400 cubic feet, yielding a revenue of £1,999 12s. 10d. The total amount of gas rentals, meter rents and stove hire was £371,197 14s., being 2.72 per cent. increase on the previous year, and the year's work resulted in a gross profit of £92,200 13s. 6d., street lighting maintenance, interest charges, and sinking fund requirements reducing the gross to £25,452 net profit. The maximum charge for gas was 2s. 8d. per thousand cubic feet. The total number of meters in use is 77,655, or an increase for the year of 975. The total length of mains is returned at 657 miles. This shows that Mr. Nickson has the care of a huge establishment. One feature that seemed peculiar to us is the comparatively small number (1,609) of cooking and heating stoves in use, when compared with the large number (77,655) of consumers' meters in duty.

GOING ON WITH THE GOOD WORK.—The new proprietors of the Utica (N. Y.) Electric and Gas Company are actively engaged in extending their conduit system, which by Sept. 1st will have had 9 miles added to its former length. A Lungren lamp is to be placed in the assembly room of the City Council.

TO LIGHT THE CITY'S WHARVES.—The contract for lighting the principal wharves in Pittsburgh, Pa., has been awarded to the Allegheny County Light Company. The Company is to furnish twenty 2,000-candle power arcs, receiving therefor \$180 each per annum. Is not that a pretty steep price?

POSTPONED.—The sale of the right to erect poles and to string wires for the purpose of furnishing a complete system of arc and incandescent lights and motor power for Flushing, L. I., which was to have taken place in the Town Hall, at 4 P.M., Monday, Aug. 1, was postponed until the first Monday in September, same hour and place. Mr. Jno. H. Wilson, President of the Board of Village Trustees, naively explains

that no sale was had on the appointed day because of the non-attendance of bidders. Sufficient reason, surely. Better luck in September—perhaps. It will be cooler then.

TO BE RUN BY AN OTTO GAS ENGINE.—The Washington (Ind.) Gas Light Company has purchased an arc light plant of the Waterhouse type. It is to be operated by a 25-horse power Otto gas engine.

PRICE OF GAS REDUCED.—On Aug. 3 the Directors of the Ottawa (Can.) Gas Light Company decided to reduce the price of gas to \$2 per thousand cubic feet.

CONSOLIDATED.—The Excelsior Electric Light and the Stillwater Gas Light Companies, of Stillwater, Minn., have been consolidated. It is expected that the water gas plant now in process of erection will be ready for duty by Oct. 1.

WILL THEY GET A CONTRACT?—At a meeting of the Des Moines (Iowa) City Council, held on 1st inst., Alderman Morris succeeded in securing the passage of a resolution ordering that bids be received from the electric light companies for lighting the city when the present contract with the Capital City Gas Light Company shall have expired. Ald. Morris is taking time by the forelock, for the gas contract holds good until Jan. 1.

THE SUBSCRIPTION BOOKS ARE OPEN.—At a recent meeting of the Directors of the Louisville (Ky.) Electric Light Company, held Aug. 2, J. S. Briggs was elected President and E. B. Lapping was chosen Secretary and Treasurer. Books for the purpose of entering the names of intending stock purchasers were opened. The Company's officials are in communication with the owners and patentees of several systems of electric lighting, but have not yet determined upon a selection.

ANNUAL ELECTION, JAMAICA PLAIN, MASS.—At the annual meeting of the Directors of the Jamaica Plain Gas Light Company the following Directors were chosen: Messrs. John C. Pratt, C. F. Curtis, A. H. Wing, M. R. Wendell, A. J. Peters, I. P. George, and F. Seaver. Subsequently Mr. John C. Pratt was elected President, Mr. I. P. George being chosen Clerk and Treasurer. A semi-annual dividend (the 60th) of 4 per cent. was declared.

A TIE VOTE.—At a special election, held on Aug. 8, by the taxpayers of the town of Canastota, N. Y., for the purpose of determining whether or not the sum of \$2,000 should be raised by special tax for lighting the streets by electricity during the ensuing year, 166 votes were polled. A count proved that 83 were in favor of the project, while an equal number opposed the plan. Another ballot has been ordered.

Driving Dynamos with Short Belts.

An English authority asserts that when fast dynamos are driven by belting there is a waste of power owing to friction between the driven spindle and its bearings. This is usually kept small by using a long belt so as to obtain a long angle of contact of the belt with the small driven pulley. But long belts are inconvenient, and in confined spaces, as on board ships or in guards' vans, impracticable. But with small belts used in the ordinary way the small angle of contact of the belt with the driven pulley necessitates a large tension on the belt, causing considerable pressure on the bearings and waste of power by friction. Various plans have been devised for overcoming this difficulty; for instance, the tightening pulley of Messrs. Mather and Platt, and forms of friction gearing, including the ingenious one of Mr. J. S. Raworth for driving dynamos.

Professors Ayrton and Perry have recently brought out another method. It consists in hanging the dynamo pulley from a short belt passing round the engine flywheel, the belt being only just long enough to embrace the flywheel and dynamo pulley without the two being brought into contact. The dynamo is supported so as to turn round an axis at right angles to the axis of rotation of the armature. The method of fixing the dynamo is to remove the pulley from the spindle and fix the dynamo in a cradle turning on trunnions in such a position that the dynamo and cradle just balance. Then if p_1 , p_2 be the pressure of the armature spindle on the two bearings, respectively nearer to and further from the pulley end of the dynamo, $p_1 + p_2$ will be equal to the weight of armature commutator and spindle. The pulley, which is heavier than an ordinary dynamo pulley, and of cast iron, is now keyed to the armature spindle and hung in the belt, and as the entire weight of the pulley is supported by the belt, the dynamo by itself still balances, and the pressures on the bearings are simply p_1 , p_2 as before.



A. M. CALLENDER & CO.,

PROPRIETORS.

Editor—JOS. R. THOMAS, C.E.
Asst. Editor—T. J. CUNNINGHAM.
Manager—C. E. SANDERSON.

PUBLISHED ON THE 2ND AND 16TH OF EACH MONTH
At No. 42 Pine Street, New York.

This is a recognized official organ of—

LIGHT, HEAT, STEAM, WATER-SUPPLY,
VENTILATION, SANITARY IMPROVEMENT,
AND GENERAL SCIENCE.

TERMS

SUBSCRIPTION—Three Dollars per annum, in advance.

AGENTS

NEW YORK—AMERICAN NEWS Co. 39 and 41 Chambers St.
BOSTON—S. M. PETTENGILL & Co., 6 State Street.
PHILADELPHIA—PRATT & Co., Corner 9th and Arch Streets.
England—C. W. HASTINGS, 22 Buckingham St., London, W C.
Germany—B. WESTERMANN & Co., of New York

TUESDAY, AUG. 16, 1887.

Notes from the West.

By RETORT.

AUGUST 8, 1887.

Mr. H. C. Thompson, the former agent of the American Meter Company, at Cincinnati, O., assumed charge of the Spokane Falls, Wash. Ter., Gas Company on August 1st.

Mr. Chas. S. Ferson, bookkeeper for the Council Bluffs (Ia.) Gas Company, was drowned while boating on Lake Manawa on August 5th. Mr. Ferson, with other excursionists, was returning home after a day's outing, when a sudden squall drove their steamer against some hidden obstruction with such force as to open a gap in the hull of the vessel. The latter speedily filled and sank in a very few minutes. Seven persons lost their lives by this disaster.

The City Council of Shelbyville, Ills., at its last meeting, held on the 2d inst., voted unanimously for the adoption of a system of lighting the city by electricity, the same to be furnished by the Shelbyville Water Company. The Mayor, after investigating the matter, refused to sign the ordinance. Shelbyville, at last accounts, did not have a gas company, so that for once it cannot be claimed that the gas company "owns the Council."

I note a chronological error in the last issue of the *Scientific American*, for, in the course of an article copied from *Invention*, it is stated: "The first shop lighted in London by this new method (coal gas) was Mr. Ackerman's, in the Strand, 1840." The shop of Mr. Ackerman, according to "Newbigging's Handbook," and "King's Treatise," as well, was lighted 28 years earlier, or in 1812. Mr. Clegg, who had charge of that work, becoming the engineer of the

chartered Gas Light and Coke Company during the succeeding year (1813), while from the same authority we learn that Mr. Winsor lighted Pall Mall in 1807.

Something of a flutter was caused in Chicago's financial circles by a rumor, which became current early in the week, to the effect that the Chicago Gas Light and Coke Company was about to issue \$5,000,000 to \$7,000,000 of bonds for improvements. Reportorial investigation failed equally to establish or disprove the truthfulness of the report, but a prominent broker, however, intimated a knowledge of the matter, and virtually admitted the fact of such an issue in the near future. He further stated that the Trust would, in October next, begin paying a quarterly dividend of one per cent.

At a recent meeting of the Municipal Assembly of St. Louis, Delegate Stern introduced a resolution, which he claims was offered in obedience to an apparent popular demand, to investigate the terms of the St. Louis Gas Trust agreement, into which the old St. Louis, the Carondelet and the water gas companies had entered. This investigation is to ascertain if the water gas franchise is being violated in the pooling of the business of the companies. Mr. Stern, in a subsequent interview, is reported as saying: "The newspapers and the people say they are pooling, and if that is so we want to know how and to what extent the law is being violated. The city is a stockholder in the St. Louis Gas Light Company, and especially for this reason we ought to know all about this secret business arrangement. When the committee is organized we shall go at once to the investigation of the organization of the Gas Trust, and discover, if possible, what it is and who is in it. We should have begun work on the investigation before, but it is likely to be an arduous and time-consuming affair, and we haven't had the time to give to it. After we begin we can continue our work beyond the adjournment of the Assembly, if we find it necessary."

A Fuel Gas Plant in Pittsburgh, Pa.

The *American Manufacturer* says that no little interest has been excited by the announcement that a plant is being built in Pittsburgh for the manufacture of fuel gas, and no little inquiry has been made as to the occasion for such a works. It was suggested that Pittsburgh, being so favored with natural gas, would certainly not require a fuel gas plant, at least until natural gas was practically exhausted, a time so far in the future as to make any preparation for such an event at this date somewhat previous.

Inquiry develops the fact that this plant is being erected by the Fuel Gas and Electric Engineering Company, Limited, which is a Pittsburgh organization, for the purpose of exhibiting their new gas making process for the manufacture of fuel gas in localities where natural gas does not exist, and to test coals from different sections of the country, in order to determine their fuel gas value for metallurgical, steam and domestic uses. This company believe that they have completely solved not only the problem of the economic production of fuel gas, but every question connected with the distribution and utilization of gas under pressure. The plant above referred to will be completed about the first of September, and will have a capacity for making fuel gas on a large

scale—about a million cubic feet per day. Either bituminous or anthracite coal can be used as the basis of the process. The gas will have a higher heating power than what is known as water gas, will have a pungent odor, and its cost, when made in districts where coal is abundant—say, for example, in Cincinnati or St. Louis—will be so low that its use cannot fail to become universal. It is also believed that manufacturing interests using this method of producing fuel gas will be able to maintain themselves in respect to fuel cost against the competition of other centers where natural gas exists in abundance. There is practically no limit to the quantity that can be manufactured at the works erected upon the plans of this Company, whether the demand be for thousands or millions of cubic feet per day.

This Company, which has been engaged in perfecting its plans for some months, will be ready some time in September to furnish plans for the installation of a complete gas plant in any locality, covering not only the manufacture of gas, and its safe and economic conveyance, but also its utilization in the best manner. Their engineering plans have been carefully worked out, and are so arranged as to include, if desired, the utilization of present piping systems of illuminating gas plants, changing district by district from their present use to that of distributing heating gas, while, as we have already pointed out in the *Manufacturer*, they will be prepared to change the system of illumination from gas to electric lighting.

The Market for Gas Securities.

The ostensible market quotations for Consolidated gas have been of the most fantastic sort during the fortnight. At one time the operators on the bear side actually marked the asking price down to 72, a figure but slightly in excess of the one at which the shares sold when they first made their appearance in the street. Some genuine transfers undoubtedly took place at and below 73, but the sellers will live to regret their haste, for there is no valid reason why Consolidated gas should be rated at anything below 85. A recent issue of the *New York Daily Times* reports that a prominent member of the stock exchange, who has large interests in the Consolidated Company, explains the situation in the following manner:

"One of the features of the bearish attacks has been to assail investment shares. The bears find it easy to mark down prices, owing to the absence of speculative dealing; but oh, how hard to cover when the turn comes! The disorganization of holders and no concerted support invites attack. Just such an inviting danger to bears will Consolidated Gas prove. People will burn gas, good crops or bad crops; and, with an increase of consumption over last year of nearly 30 per cent., and with prospective increase of dividends, a short interest of over 10,000 shares and the assistance of the heavy investment interest, the bear raiders can be made to feel uncomfortable at 80, or even at a ten-point advance."

When the settling day comes many a bear on Consolidated will be troubled with a very sore head. At the close of last week the price hardened to 76, and every indication points to higher figures. Equitable is somewhat weaker, and Mutual shows no improvement. Brooklyn shares are neglected, although an occasional inquiry is made for old Brooklyn gas. We note that Williamsburgh is decidedly weak. Baltimore Con. has moved up a peg or two, while Chicago Gas Trust is bid for at 50.

Gas Stocks.

Quotations by Geo. W. Close, Broker and Dealer in Gas Stocks.

16 WALL ST., NEW YORK CITY.

AUGUST 16.

All communications will receive particular attention.
The following quotations are based on the par value of \$100 per share.

	Capital.	Par.	Bid	Asked
Consolidated.....	\$35,430,000	100	75 3/4	76
Central.....	440,000	50	30	—
“ Scrip.....	220,000	—	47	57
Equitable.....	2,000,000	100	118	122
“ Bonds.....	1,000,000	—	113	115
Harlem, Bonds.....	170,000	—	—	—
Metropolitan, Bonds....	658,000	—	110	113
Mutual.....	3,500,000	100	93	96
“ Bonds.....	1,500,000	1000	101	—
Municipal, Bonds.....	750,000	—	—	—
Northern.....	125,000	50	30	—
“ Scrip.....	108,000	—	—	—
Yonkers.....	—	50	—	80
Richmond Co., S. I.	300,000	50	50	—
“ Bonds.....	12,000	—	—	—
Gas Co's of Brooklyn.				
Brooklyn.....	2,000,000	25	104	106
Citizens.....	1,200,000	20	56	—
“ S. F. Bonds....	320,000	1000	—	103
Fulton Municipal.....	3,000,000	100	138	139
“ Bonds....	300,000	—	—	106
Peoples.....	1,000,000	10	60	62
“ Bonds (5's).....	368,000	—	97	—
“ “ (6's).....	94,000	—	100	—
Metropolitan.....	1,000,000	100	82	84
Nassau.....	1,000,000	25	101	103
“ Ctf's.....	700,000	1000	100	—
Williamsburgh.....	1,000,000	50	115	120
“ Bonds... ..	1,000,000	—	111	—
Out of Town Gas Companies.				
Boston (Mass.) Gas Co.	2,500,000	500	204	208
Buffalo Mutual, N. Y. ...	750,000	100	90	95
“ Bonds... ..	200,000	1000	95	100
Citizens, Newark.....	1,000,000	50	140	145
“ “ Bonds.	45,000	—	—	—
Chicago Gas Trust.....	25,000,000	100	50	53
Cincinnati G. & C. Co..	6,000,000	100	187	188
Consolidated, Balt.	6,000,000	100	56	—
“ Bonds....	3,600,000	—	107	107 1/2
Chesapeake, Balt.....	1,500,000	100	75	80
“ “	1,000,000	—	100	102
Consumers Toronto....	1,000,000	50	192	—
Central, S. F., Cal.....	—	—	80	100
Capital, Sacramento, Cal.	—	—	57 1/2	60
Hartford, Conn.....	750,000	25	140	142
Jersey City.....	750,000	20	168	—
Laclede, St. Louis, Mo.	2,000,000	100	125	—
Louisville, Ky.....	2,570,000	50	130	132
Little Falls, N. Y.....	50,000	100	95	100
“ Bonds	25,000	—	100	103

Advertisers Index.

	Page
GAS ENGINEERS.	
Jos. R. Thomas, New York City	120
Wm. Henry White, New York City.....	120
Wm. Mooney, New York City.....	120
William Gardner, Pittsburgh, Pa.....	120
GAS WORKS APPARATUS AND CONSTRUCTION.	
James R. Floyd, New York City	123
T. F. Rowland, Greenpoint, L. I.....	123
Deily & Fowler, Phila., Pa.....	123
Kerr Murray Mfg. Co., Fort Wayne, Ind.....	122
Stacey Mfg. Co., Cincinnati, Ohio.....	123
Bartlett, Hayward & Co., Baltimore, Md.....	113
Morris, Tasker & Co., Limited, Phila., Pa.....	122
Davis & Farnum Mfg. Co., Waltham, Mass	90
R. D. Wood & Co., Phila., Pa.....	122
Southwark Foundry and Machine Co., Philadelphia, Pa.....	122
Bouton Foundry Co., Chicago, Ills	119
Smith & Sayre Manufacturing Co., New York City.....	123
PROCESSES.	
National Gas Light and Fuel Co., Chicago Ills.	114

GAS AND WATER PIPES.

Gloucester Iron Works, Phila., Pa	120
Mellert Foundry and Machine Co., Reading, Pa. (John Fox, Selling Agent, N. Y.).....	120
Cincinnati and Newport Iron and Pipe Co., Newport, Ky....	120
Ohio Pipe Co., Columbus, Ohio.....	120
Pancoast & Rogers, New York City.....	120
M. J. Drummond, New York City	120
Wells Rustless Iron Co., New York City.....	112
R. D. Wood & Co., Phila., Pa.....	122

GAS ENGINES.

Siedelcher, Schumm & Co., Phila., Pa.....	128
Clerk Gas Engine Co., Phila., Pa.	115

RETORTS AND FIRE BRICK.

J. H. Gautier & Co., Jersey City; N. J.....	118
B. Kreisler & Sons, New York City.....	118
Adam Weber, New York City.....	118
Laclede Fire Brick Works, St. Louis, Mo.....	118
Brooklyn Retort and Fire Brick Works, Brooklyn, N. Y.	118
Borgner & O'Brien, Phila., Pa.....	118
James Gardner, Jr., Pittsburgh, Pa.....	118
Henry Maurer & Son, New York City.....	118
Chicago Retort and Fire Brick Works, Chicago, Ills.....	118
Baltimore Retort and Fire Brick Co., Baltimore.....	118
Oakhill Gas Retort and Fire Brick Co., St. Louis, Mo.....	118
Evens & Howard, St. Louis, Mo.....	119
Cincinnati Gas Retort and Fire Brick Works, Cincinnati, O.	119
Emil Lenz, New York City.....	119

SCRUBBERS AND CONDENSERS.

G. Shepard Page, New York City.....	121
R. D. Wood & Co., Phila., Pa.....	122

REGENERATIVE FURNACES.

Bartlett, Hayward & Co., Baltimore, Md.....	113
Fred. Bredel, New York City.....	119

GAS GOVERNORS.

T. C. Hopper, Phila., Pa.....	116
Connelly & Co., New York City.....	115

CEMENTS.

C. L. Gerould, Manchester, N. H.....	118
--------------------------------------	-----

GAS ENRICHERS.

Standard Oil Co., Cleveland, Ohio.....	124
--	-----

GAS METERS.

Harris, Griffin & Co., Phila., Pa.....	126
American Meter Co., New York and Philadelphia	127
The Goodwin Gas Stove and Meter Co., Philadelphia, Pa....	127
Helme & McIlhenny, Phila., Pa.....	127
D. McDonald & Co., Albany, N. Y.....	127
Nathaniel Tufts, Boston, Mass.....	126

EXHAUSTERS.

P. H. & F. M. Roots, Connersville, Ind.....	114
Smith & Sayre Manufacturing Co., New York City.....	123
Willbraham Bros., Philadelphia, Pa.....	115
Connelly & Co., New York City	115

GAS COALS.

Penn Gas Coal Co., Phila., Pa.....	125
Perkins & Co., New York City	124
Newburgh Orrel Coal Co., Baltimore Md	125
Despard Coal Co., Baltimore, Md.....	125
Chesapeake and Ohio R.R. Coal Agency, N. Y. City.....	125
Westmoreland Coal Company, Phila., Pa.....	125
Monongahela & Peters Creek Gas Coal Co., Pittsburgh, Pa....	125

CANNEL COALS.

Perkins & Co., New York City.....	124
J. & W. Wood, New York City.....	124

VALVES.

Ludlow Valve Manufacturing Co., Troy, N. Y.	116
John McLean, New York City.....	116
Chapman Valve Manufacturing Co., Boston, Mass.....	116
R. D. Wood & Co., Phila., Pa.....	122

ENGINES AND BOILERS.

Jarvis Engineering Co., Boston, Mass.....	115
---	-----

PURIFYING MATERIAL.

S. H. Douglas, Ann Arbor, Mich.....	119
Connelly & Co., New York City.....	115

GAS LAMPS.

The Siemens-Lungren Co., Philadelphia, Pa.....	121
G. Shepard Page, New York City.....	88
Albo-Carbon Light Co., Newark, N. J.....	112
Standard Gas Lamp Co., Phila., Pa.....	119

PURIFIER SCREENS.

John Cabot, New York City.....	119
Geo. A. Mills, Baltimore, Md.....	119

GAS STOVES.

American Meter Co., New York and Philadelphia.....	117
The Goodwin Gas Stove and Meter Co., Phila., Pa.....	96

STREET LAMPS.

J. G. Miner, Morrisania, New York City.....	111
Bartlett Street Lamp Mfg Co., New York City.....	116

BURNERS.

C. A. Gefroerer, Phila., Pa.....	124
----------------------------------	-----

STEAM BLOWER FOR BURNING BREASE.

H. E. Parson, New York City.....	120
----------------------------------	-----

GASHOLDER TANKS.

W. C. Whyte, New York City.....	112
---------------------------------	-----

GAS FIXTURES.

Mitchell, Vance & Co., New York City.....	116
---	-----

COKE CRUSHER.

C. M. Keller, Columbus, Ind.....	125
----------------------------------	-----

GAS BAGS.

Peerless Manufg Co., New York City.....	115
---	-----

ELECTRICAL APPARATUS.

Waterhouse Electric & Manufg Co., Hartford, Conn.....	112
---	-----

Position Desired.

A man of correct habits desires a position
As Superintendent, Engineer, or Con-
structor of Gas Works.

Thoroughly understands water gas processes, as well as coal, oil, or wood gas. Perfectly familiar with the erection of gas works in every detail; also designing, drawing, analysis, photometry, etc. Will take a non-paying works and put it on a paying basis; or take charge of the erection of a works and manage it after completion. Address
676-2 "G. A. S.," care this Journal.

Engagement Desired.

The advertiser, an English Gas Engineer, age 25, seeks an engagement

As Gas Works Manager or Assistant Manager.

Thoroughly understands the manufacture and distribution of gas, and is a good draughtsman and chemist. Address
672-6t "H.," care this Office.

FOR SALE,

Two Sinuous Friction Condensers,

Each 1 ft. 3 in. wide by 11 ft. 3 in. long, and 18 ft. high, of sufficient capacity for 235,000 cu. ft. per day. Apply to
665-12 PETER COFFEY, Supt Gas Co., Peoria, Ill.

ENGLISH

"Journal of Gas Lighting."

Issued weekly. New volume commences Jan. 1, 1887. Price, \$7 per annum. Subscriptions taken by

CHARLES NETTLETON, Agent for U. S.,

No. 115 BROADWAY, N. Y. CITY.

THE GLOBE
STREET LAMP.



MINER'S PATENT
STREET LAMPS.

Are adapted for use of Streets, Parks,
Depots, Ferries, & Private Grounds.

WITH POSTS OR BRACKETS.

Jacob G. Miner,

No. 823 Eagle Ave., New York, N. Y.

THE ALBO-CARBON LIGHT.



THIS SYSTEM HAS SHOWN ITSELF IN THOUSANDS OF CASES—IN HALLS, CHURCHES, PICTURE GALLERIES, CONCERT HALLS, RESTAURANTS, BANKS, CLUBS, STORES, OFFICES, and PRIVATE RESIDENCES—TO BE THE

Best Adapted and Most Successful Method of Gas Lighting Ever Offered.

The SOFTNESS AND PURITY OF THE LIGHT make it most desirable for Office and Household Uses. Its BRILLIANCY and POWER render it unrivaled for lighting Halls, Churches, etc. Its ECONOMY secures for it general favor wherever used.

NOTICE.—Suits are pending in the United States Circuit Courts in Illinois and Pennsylvania against various parties for infringement of our Letters Patent No. 247,925, dated October 4, 1881, and No. 333,862, dated January 5, 1886. The first of these suits has come up for hearing, and an injunction has been granted therein. The second of said suits has not yet been reached for hearing. All persons are cautioned against manufacturing, selling, or using any apparatus or material which infringes our patents. We intend to prosecute all parties infringing patents owned by us.

ALBO-CARBON LIGHT CO. (Sole Manufacturers for the United States) Main Office, Newark, N. J.

ARC AND INCANDESCENT LIGHTING.

Steady Lights, Economy of Power,
INSTANTANEOUS AUTOMATIC REGULATION,

ARE ALL CONTAINED IN

THE WATERHOUSE SYSTEM

A Complete System that will knock out competition and secure the trade. We invite the most critical investigation, as we have no "outs" to apologize for.

Send for Catalogue!

Send for Catalogue!

THE WATERHOUSE ELECTRIC AND MFG. COMPANY,
Factory, Colt's West Armory. **Hartford, Conn.**

To All Whom It May Concern!

The SIEMENS-LUNGREN COMPANY hereby warns the public against the use of various infringing Regenerative Gas Lamps which are offered for sale. This Company has heretofore delayed bringing suit to enjoin the manufacture or importation of such infringing lamps, solely because of the practical worthlessness of the infringing devices; and although, in each instance, they infringe some one or more of the various patents owned or controlled by this Company, they have fallen into disuse sooner than any suit could be brought to a hearing. As, however, the introduction of these infringing lamps has tended to discredit the practicability of our Company's system of regenerative gas lighting, we have instructed our Attorneys, Messrs. Geo. Harding, C. S. Whitman, and Silas W. Pettit, to give notice that legal proceedings will in future be taken against all such infringers.

THE SIEMENS-LUNGREN CO., 21st St. & Washington Av., Phila., Pa.

Water & Gas Pipe.

RUSTLESS Send for New Catalogue. **RUSTLESS**

The WELLS RUSTLESS IRON COMPANY,
Nos. 7 and 9 Cliff Street, New York City.

GASHOLDER TANK CONSTRUCTION, ETC.

Gas Companies and others about to erect Gasholders will find it profitable to consult W. C. WHYTE, who for over thirty years has made a specialty of

Holder Tank Excavation and Mason Work.

Fifty tanks now in operation show the sort of work done. Address

W. C. WHYTE, No. 15 Cortlandt St., N. Y. City.

BOOKS.

DISTILLATION OF COAL TAR AND AMMONIACAL LIQUOR.

By GEORGE LUNGE. Price \$8.50.

A TREATISE ON THE COMPARATIVE COMMERCIAL VALUES OF GAS COALS AND CANNELS.

By DAVID A. GRAHAM. 8vo., Cloth. Price \$3.

Orders for these books may be sent to this office.

A. M. CALLENDER & CO.,
42 PINE ST., N. Y. CITY.

BARTLETT, HAYWARD & CO.

Baltimore, Md.

Munich Regenerative Furnace, System Drs. Schilling & Bunte.

Greatest durability; minimum of attention; complete distillation in 3½ hours; 10 to 13 pounds of coke to hundred-weight of coal; no clinker; no carbonic oxide in regenerative flues.

TWO AND THREE-LIFT TELESCOPIC GASHOLDERS,

With Wrought Iron Tanks, constructed above ground, of any magnitude.

Condensers, Scrubbers, Purifiers, Bench Castings, Roofs, Boilers, Etc.

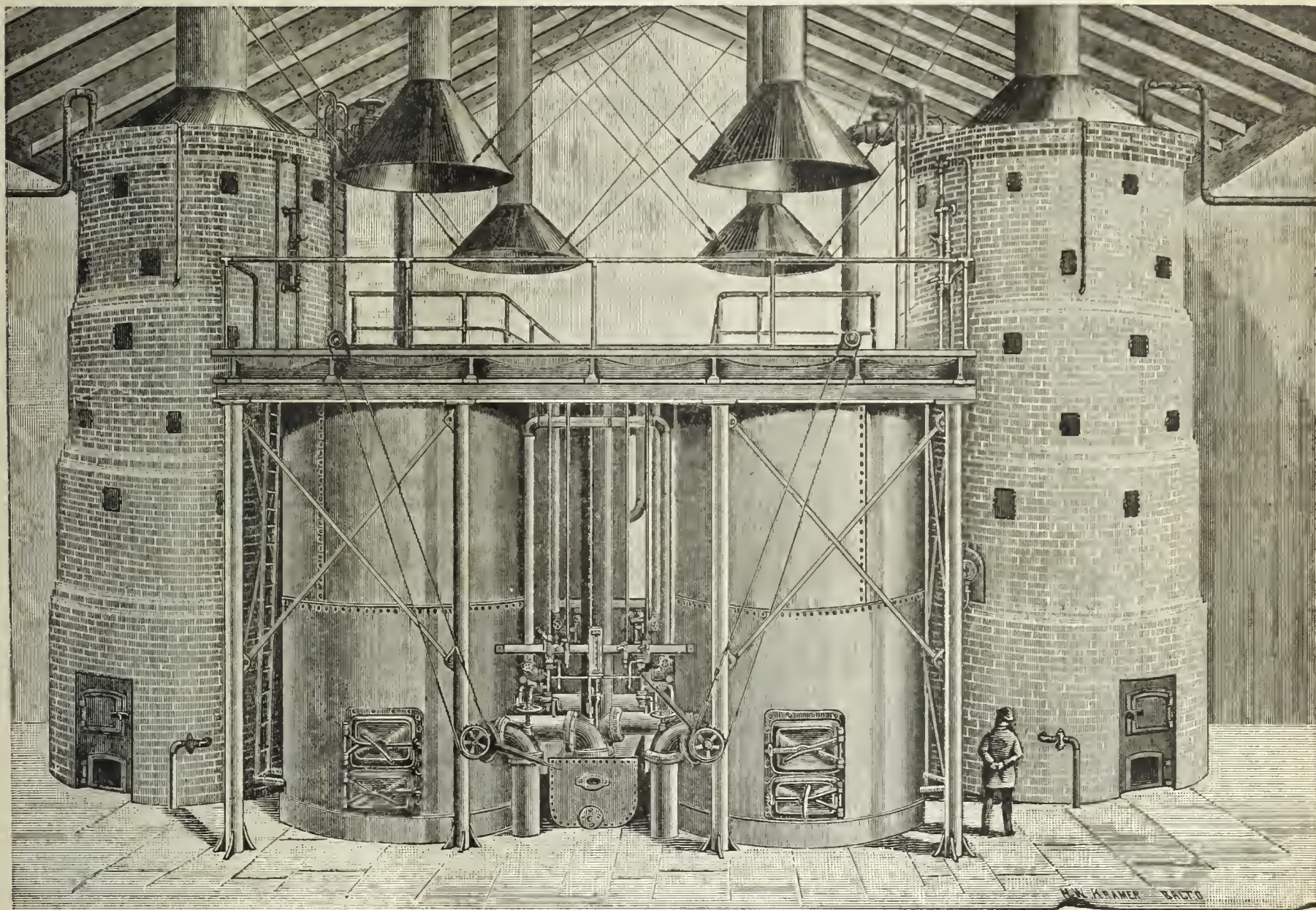

The Wilkinson Water Gas Process.

Introducing the Munich Regenerative Furnace for Coal Gas, we find on the part of many Gas Companies the desire to combine to a greater or less extent an efficient system of making high candle power Water Gas; and with a view of enabling this to be done WITHOUT EXCESSIVE CHARGES FOR PATENT RIGHTS, ETC., we have acquired, by purchase, the exclusive right to construct all the Water Gas Apparatus under the valuable "Wilkinson" Patents.

The results obtained by this Process are far better than those obtained by any other apparatus, especially where an illuminating gas of high candle power or a fuel gas of intense temperature is required.

The Process is uninterrupted, making gas of uniform quality and quantity. Its greatest advantages are maximum production with minimum material and labor, combined with great durability of apparatus.

The Process is in successful operation at the works of the N. Y. Mutual Gas Company, New York; Consolidated Gas Company, Baltimore, Md.; the Hudson County Gas Light Company, of Hoboken, N. J.; and at Rye, N. Y.

We shall be glad to give further detailed information upon application.

Sole Agents for the Celebrated Hazleton Boiler.

BARTLETT, HAYWARD & CO.

EXHAUSTERS.

EXHAUSTERS.

PROCESSES.

ROOTS' NEW GAS EXHAUSTER.

St. Louis, Mo., }
 March 21, 1887. }

Messrs. P. H. & F. M. Roots, Connersville, Ind.:
 Dear Sirs—In 1872 one of your No. 5 Exhausters was placed in these works, and worked satisfactorily. In March, 1885, it was replaced by one of your No. 6 Exhausters. The latter has been in almost constant use the past two years, has worked up to all my expectations, and is to-day in apparently as good condition as when first set up. It has not cost one cent for repairs in all that time. I have also

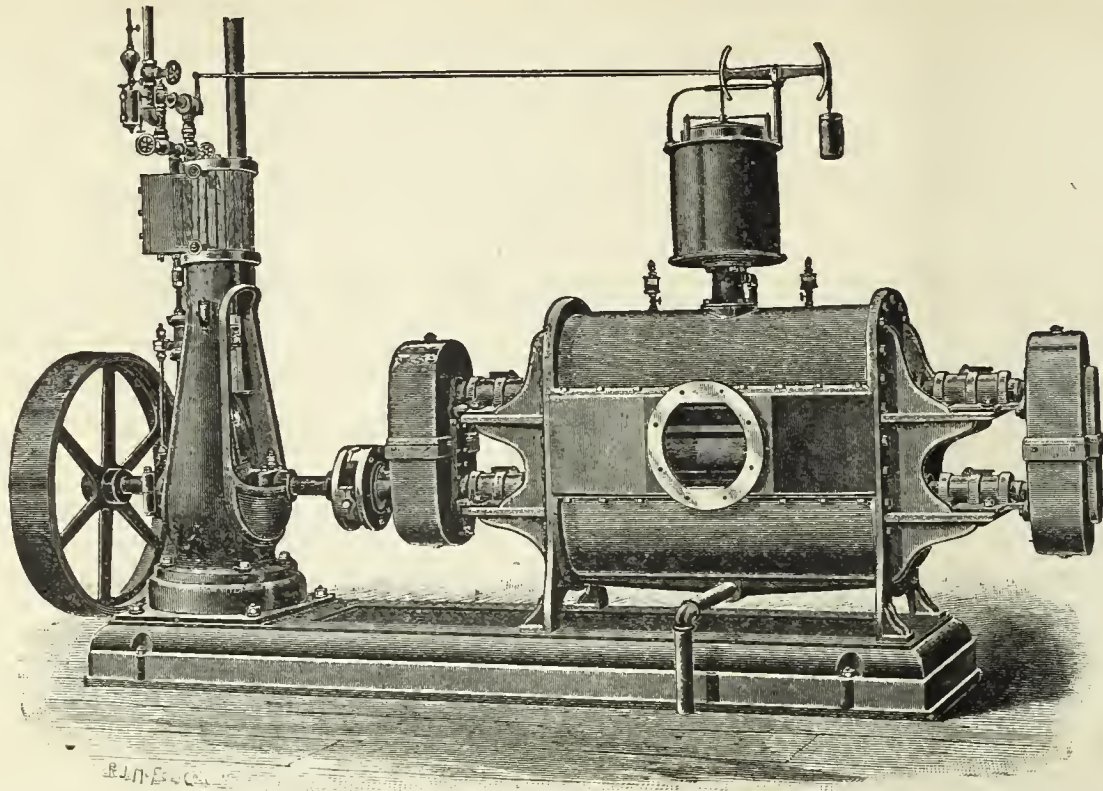

had one of your No. 1 Exhausters, with Engine on same bed-plate, fitted with your valves and Huntoon Governor, placed in a small works under my control, and in its operation it seems as near perfection as I ever expect an Exhauster to become. Without in the least disparaging Exhausters of other makes, I may say that your Exhauster may be safely recommended as unsurpassed by any other, to those requiring such machines.

Yours respectfully,
 FREDERIC EGNER,
 Eng. and Supt.

CONSTRUCTED ON ENTIRELY NEW PRINCIPLES.

THE ONLY EXHAUSTER MADE IN WHICH

The Internal Operating Parts Consist of Only Two Pieces, Each Cast Entire in One Piece.

Send for Descriptive Catalogue and Price List.

P. H. & F. M. ROOTS, Patentees and Manufacturers, **CONNERSVILLE, IND.**

S. S. TOWNSEND, Gen. Agt., 22 Cortlandt St., N. Y. COOKE & CO., Selling Agts., 22 Cortlandt St., N. Y.

DURING THE PAST YEAR, THE

NATIONAL GAS LIGHT AND FUEL CO.

218 LA SALLE ST., CHICAGO,

Have Erected Twelve Sets of Water Gas Generating Apparatus under the *Springer Cupola* System. They are as follows:

Newton Illuminating Company, Newton, Kansas.—Daily capacity, 120,000 cu. ft.

Wellington Light & Heat Co., Wellington, Kansas.—Daily capacity, 120,000 cu. ft.

Chippewa Falls, Gas Light Co., Chippewa Falls, Wis.—Daily capacity, 120,000 cu. ft.

Elkhart Gas Light & Coke Co., Elkhart, Indiana.—Daily capacity, 120,000 cu. ft.

Madison City Gas Light Company, Madison, Wis.—Daily capacity, 120,000 cu. ft.

South Bend Gas Light Co., South Bend, Indiana.—Daily capacity, 250,000 cu. ft.

Sheboygan National Gas Comp'y, Sheboygan, Wis.—Daily capacity, 120,000 cu. ft.

Salina Gas Light Company, Salina, Kansas.—Daily capacity, 120,000 cu. ft.

Rathbun Company, Deseronto, Province Ontario.—Daily capacity, 80,000 cu. ft.

Jefferson City Gas Light Co., Jefferson City, Mo.—Daily capacity, 120,000 cu. ft.

Mankato Gas Light Company, Mankato, Minnesota.—Daily capacity, 80,000 cu. ft.

Minneapolis Gas Lt. & Coke Co., Minneapolis, Minn.—Daily capacity, 1,000,000 cu. ft.

1886

1886

CONNELLY & CO., LTD.,

SOLE MANUFACTURERS OF THEIR PATENTED SPECIALTIES.

"IRON SPONGE." Saves money, saves labor, and is the most efficient purifying agent ever offered as a substitute for lime. Now used *in every State in the Union*, and purifying daily over *twenty-five million cubic feet*. Should be used in every gas works. Its own saving will pay for it many times over.

AUTOMATIC GOVERNOR. Has been on the market but *two years*, and in that time has been introduced *more generally* than any invention ever designed for use in gas works. Over *one hundred* of them now in use. Sensitive; reliable; perfectly automatic; reduces leakage; satisfies consumers, and gives great relief to the Manager. No gas works is *complete* without one of these machines.

STEAM JET EXHAUSTER. Designed particularly for small works. Combines Exhaust Tube, Steam Governor, Gas Compensator, and Bye-Pass Valves in the most compact form possible; occupies but little space; uses very little steam; operated by ordinary workmen; saves formation of carbon in retorts; increases yield 10 to 15 per cent. Specially adapted for *mixing air* with oil gas. *No works* too small to use them profitably.

Prices given on all our specialties *delivered at any point in the United States*. Correspondence solicited.

CONNELLY & CO., LTD., No. 177 Broadway, New York City.

WILBRAHAM GAS EXHAUSTER

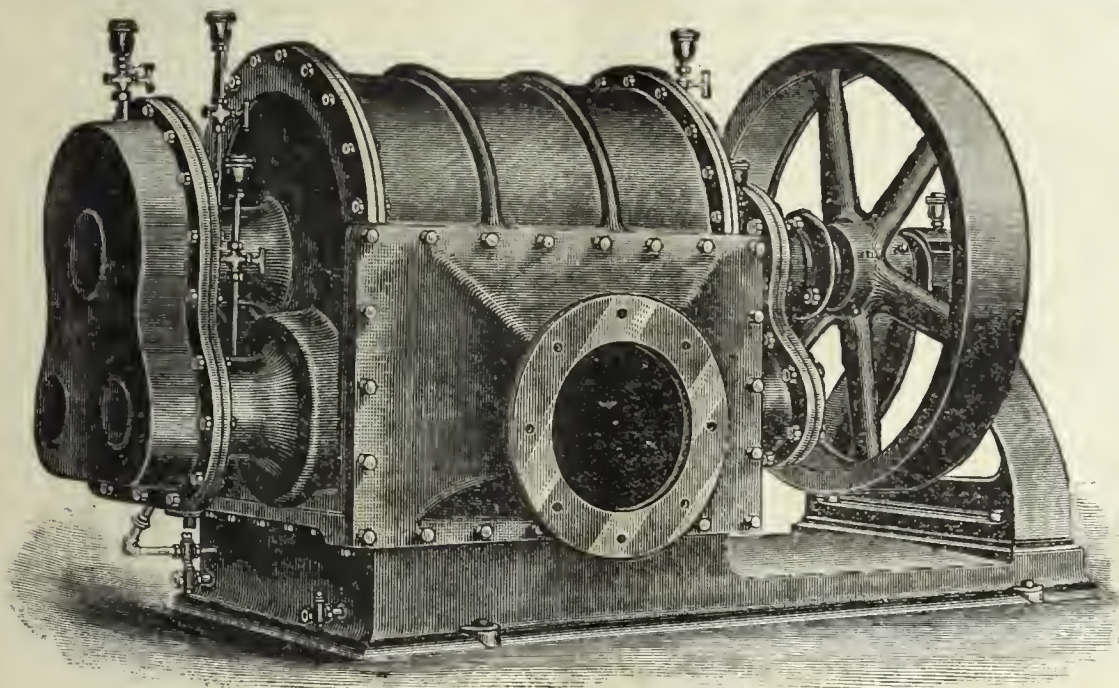

WILBRAHAM BROS.,
PHILADELPHIA, PA.

JARVIS ENGINEERING CO.,

61 Oliver St., Boston, Mass.

CONTRACTORS FOR ERECTING

COMPLETE STEAM OUTFITS FOR ELECTRIC LIGHTING STATIONS.

Steel Boilers set with Jarvis Pat. Boiler Setting,

To burn **COKE SCREENINGS** for Fuel.

ARMINGTON & SIMS CO. ENGINES,

Belted direct to Dynamos, without using Shafting.

SEND FOR CIRCULARS.

REFERENCES.—Charlestown Gas & Electric Light Co., Charlestown, Mass.; Schenectady Gas & Electric Light Co., Schenectady, N. Y.; Brookline Gas Co., Brookline, Mass.

Improved Patent
GAS BAG OR
BLADDER VALVE.

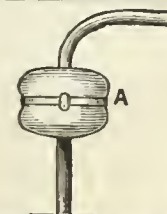

Pressure
Indicator.

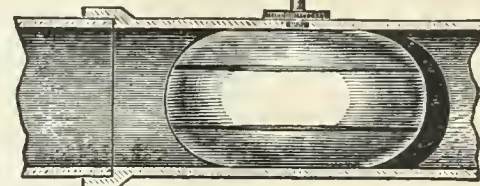

MANUFACTURED BY

PEERLESS MFG. CO., 34 Murray St., N.Y.

THE CLERK GAS ENGINE CO.,

Main Office, 1012, 1014, 1016, 1018 Filbert St., Philadelphia, Pa.

WM. W. GOODWIN, Prest.

E. STEIN, Sec.

S. LEWIS JONES, Asst. Sec.

A. J. DOTY, Supt.

The utility and convenience of the Gas Engine being no longer an open question, it only remains now for intending purchasers to select the BEST. We claim for the CLERK GAS ENGINE that it is equal to any other manufactured as regards steadiness in running, simplicity, and ease of keeping in repair, and that it gives the greatest amount of power for the least money (both in first cost and expense of running) of any engine made. In support of this claim we refer to the test of the Gas Engines made under the direction of the American Institute of New York, in December, 1885, and heretofore published in these columns. These engines are especially adapted for continuous running under heavy loads, and we can refer to Engines which have run 22 hours a day for months at a time.

Made in Sizes of 5, 10, 15, 20, and 25 Horse Power. All Engines Guaranteed for One Year.



CHAPMAN VALVE MANUFACTURING CO.,

MANUFACTURERS OF

Valves and Gates for Gas, Ammonia, Water, Etc.

Also, Gate Fire Hydrants With and Without Independent Nozzle Valve. All Work Guaranteed.

WORKS & GEN'L OFFICE:
Indian Orchard, Mass.

TREASURER'S OFFICE:
72 Kilby & 112 Milk Sts, Boston, Mass.

LUDLOW VALVE MFG. CO.



OFFICE AND WORKS,
938 to 954 River Street and 67 to 83 Vail Av
TROY, N. Y.

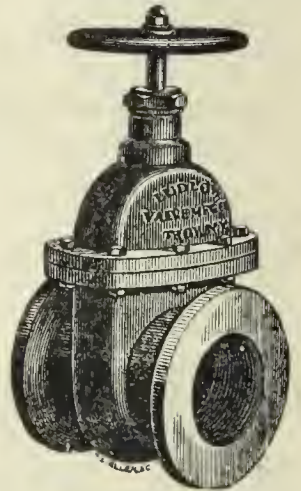

Hydraulic Main Dip Regulators, also
Check Valves, Foot Valves, Yard-
wash and Fire Hydrants.
Send for Circulars.

Valves. - Double and Single Gate, 1/2 in. to
48 in., outside and inside Screws. Indica-
tor, etc., for Gas, Water, Steam, and Oil.
Send for Circulars.

How to Reduce Leakage to Its Minimum.

USE

HOPPER'S AUTOMATIC DIFFERENTIAL GAS GOVERNOR.

Needs No Attention. Simple, Reliable, Perfectly Automatic.
"Nearly Thirty in Use."

BYE-PASSES, DRY CENTER VALVES, PRESSURE REGISTERS. Also, GOVERNORS FOR
STREET MAINS, NOT DIFFERENTIAL, and for EXHAUSTERS, GAS ENGINES, etc.

Our new Bye-Pass is threefold in its action—passes gas through, or bye-passes, or shuts off entirely.
Correspondence solicited; information given. Send for circulars and testimonials.

T. C. HOPPER & CO., - - No. 2227 Wood Street, Philadelphia, Pa.

G. S. COOK, Pres. THOS. DAVENPORT (late Davenport Bros.), Sec. & Treas

BARTLETT

Street Lamp Mfg. Co.

MANUFACTURERS OF

Bartlett's Patent

GLOBE LAMPS.

FOR

Streets, Parks, Railroad Stations, Public
Buildings, Etc.

LAMP POSTS A SPECIALTY.

Office and Salesroom

40 & 42 College Place, N. Y. City.

Gas Companies and others intending to erect lamps and posts
will do well to communicate with us.

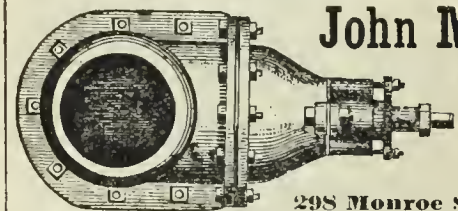
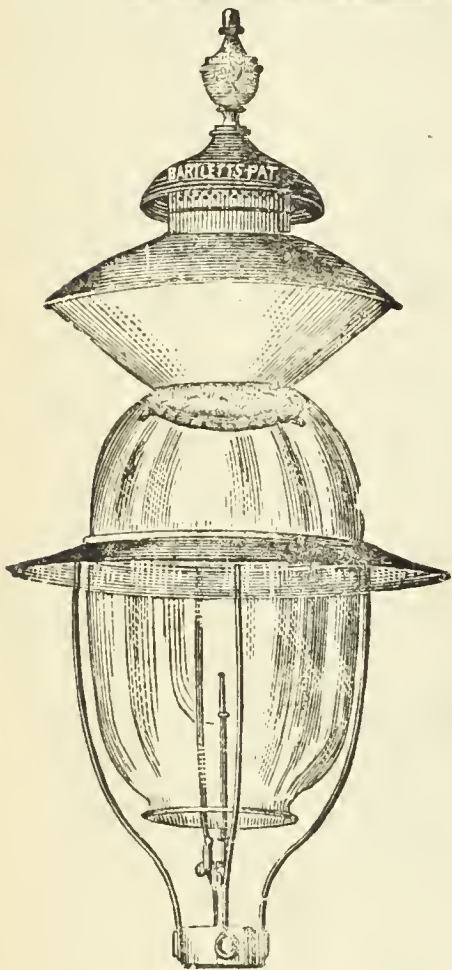

John McLean

Man'furer of

**GAS
VALVES.**

298 Monroe Street, N. Y.

MITCHELL, VANCE & CO.,

MANUFACTURERS OF

Chandeliers

and every description of

GAS FIXTURES.

Also manufacturers of Fine Gilt Bronzes and Marble Clocks.
warranted best time-keepers. Mantel Ornaments, etc.

Salesrooms, 836 Broadway, N. Y.

Special Designs furnished for Gas Fixtures for Churches, Public
Halls, Lodges, etc.

GAS AS A SOURCE OF LIGHT, HEAT, AND POWER.

By C. J. R. HUMPHREYS

A Pamphlet of twenty-nine pages, treating of the use of Gas as a
source of Light, Heat, and Power.

DESIGNED FOR DISTRIBUTION BY GAS COMPANIES AMONG THEIR CUSTOMERS AND OTHERS.

Price, 10 cents each, \$5 per 100, \$50 per 1,000.

Gas Companies can have their own imprint placed on cover without extra charge. All orders to be sent to

A. M. CALLENDER & CO.,

No. 42 Pine Street, N. Y. City.

GAS STOVES.

GAS STOVES.

GAS STOVES.

THE AMERICAN METER CO.,

MANUFACTORIES,

508 to 514 West Twenty-second St., N. Y.

Arch and Twenty-second St., Phila.

Nos. 244 & 246 North Wells Street, Chicago, Ill.

AGENCIES,

No. 177 Elm Street, Cincinnati, Ohio.

Nos. 122 & 124 Sutter Street, San Francisco Cal

No. 810 North Second Street, St. Louis, Mo.

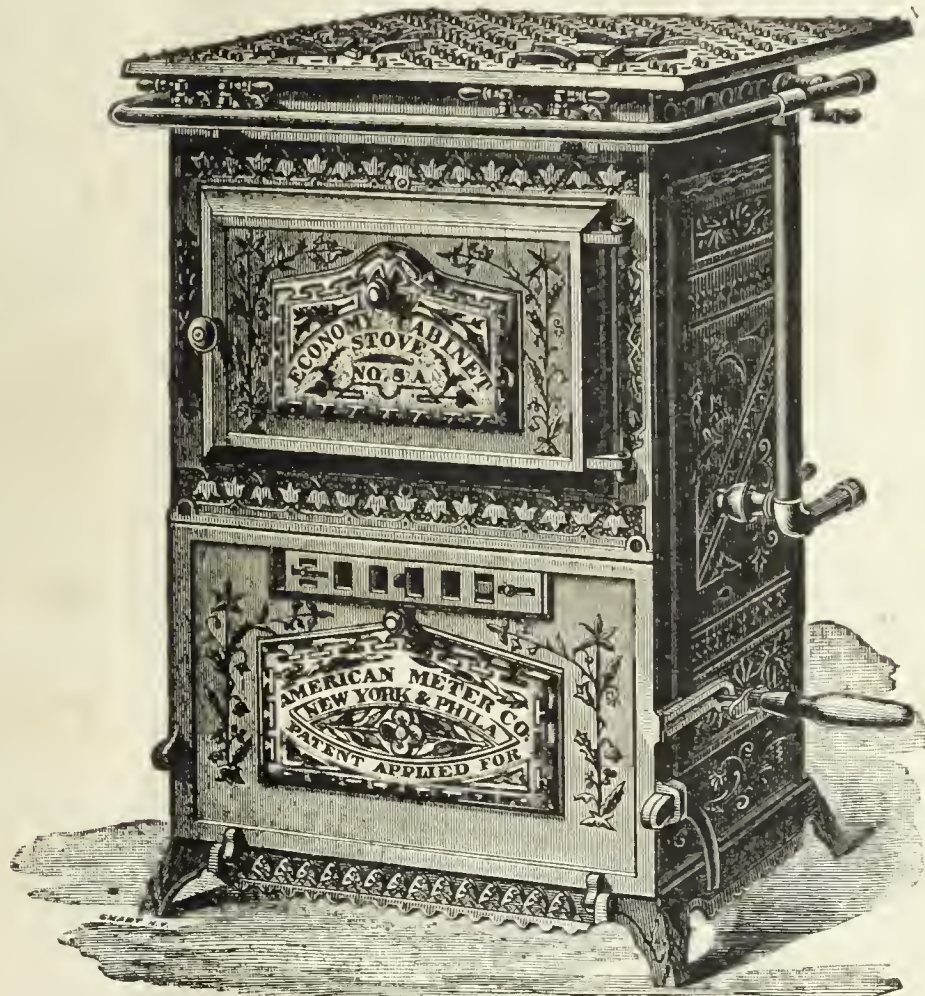

New Design Cast Iron "Economy" Cabinet Stoves.—With Open or Closed Top.

THE COMPANY MANUFACTURES

GAS STOVES FOR COOKING AND HEATING PURPOSES,

In All Sizes, for Domestic, Restaurant, and Hotel Use.

Also,

A Variety of Apparatus for Mechanical Purposes, Using Gas as Fuel.

These Stoves may be seen in operation at our Retail Store, No. 223 Sixth Avenue, N. Y. Call and examine.

SEND FOR ILLUSTRATED CATALOGUE SHOWING THE VARIOUS STYLES AND SIZES.

RETORTS AND FIRE BRICK.

J. H. GAUTIER & CO.,
CORNER OF
GREENE AND ESSEX STREETS,
JERSEY CITY, N. J.

MANUFACTURERS OF

**Clay Gas Retorts,
Gas House Tiles,
Fire Bricks, Etc. Etc.**

Ground Clay, Fire Brick and
Fire Sand in Barrels,

J. H. GAUTIER.
C. E. GREGORY.

T. B. GAUTIER.
C. E. GAUTIER.

BROOKLYN

Clay Retort & Fire Brick Works,
(EDWARD D. WHITE & CO.)

Manufacturers of Clay Retorts, Fire Brick,
Gas House and other Tile.

VAN DYKE, ELIZABETH, RICHARDS & PARTITION STS.
Office, 88 Van Dyke St., Brooklyn, N. Y.

RETORTS AND FIRE BRICK.

LACLEDE FIRE BRICK MFG. CO.,
MANUFACTURERS OF
Fire Brick, Gas Retorts,

AND

ST. LOUIS STANDARD SEWER PIPE.

Blast Furnace and Cupola Linings, every description of Fire
Clay Material, Fire Clay Flue Linings, Chimney Tops
Dry Milled and Crude Fire Clays, etc.

OFFICE AND DEPOT

901, 903, and 905 Pine Street,
ST. LOUIS, MO.

ESTABLISHED IN 1845.

B. KREISCHER & SONS,

OFFICE FOOT OF HOUSTON ST., E. R., N. Y.

Gas Retorts,

TILES, FIRE BRICK.

AND EVERYTHING IN THE FIRE CLAY LINE.

RETORTS AND FIRE BRICK.

MANHATTAN
FIRE BRICK & ENAMELLED CLAY
RETORT WORKS.

ADAM WEBER.

**CLAY GAS RETORTS
AND RETORT SETTINGS
FIRE BRICKS, TILES, ETC.,**

Office and Works, 15th Street and Avenue C., N. Y.



Works,
LOCKPORT STATION, PA.

—ESTABLISHED 1864.—

JAMES GARDNER, JR.,

Successor to WILLIAM GARDNER & SON.

Office, Rooms 19 & 20, Lewis Block,
PITTSBURGH, PA, P. O. Box 373.

Fire Clay Goods for Gas Works.

CHAS. H. SPRAGUE & SON, No. 70 KILBY STREET, BOSTON, MASS., Agents for the New England States.

OFFICE, 418 to 422 East 23d St., New York.

ESTABLISHED 1856.

WORKS, PERTH AMBOY, NEW JERSEY.

HENRY MAURER & SON,
Excelsior Fire Brick & Clay Retort Works
CLAY GAS RETORTS, BENCH SETTINGS, FIRE BRICK, TILES, ETC.

CHICAGO

Retort & Fire Brick Works,

OFFICE AND FACTORY,
Clark, Forty-Fifth, and La Salle Streets,
CHICAGO, ILL.

GEORGE C. HICKS, PRES. PAUL P. AUSTIN, SEC. & TREAS.

STANDARD

Clay Retorts and Settings.

BLOCKS & TILES

Of every Shape and Size to Order.

Standard Fire Bricks.

GEROULD'S IMPROVED RETORT CEMENT.

A Cement for patching retorts, putting on mouthpieces, and
making up all bench-work joints. This Cement is mixed ready
or use. Economic and thorough in its work. Fully warranted
stock. For recommendations and price list address

C. L. GEROULD,
Manchester, N. H.

Western Agent, H. T. GEROULD, Mendota, Ill.

OAKHILL

GAS RETORT & FIRE BRICK

Works.

Proprietors,

PARKER-RUSSELL MINING & MFG. CO.

City Office, 711 Pine Street,

ST. LOUIS, MO.

Our immense establishment is now employed almost entirely in
the manufacture of

MATERIALS FOR GAS COMPANIES.

We have studied and perfected three important points. Our re-
torts are made to stand changes of temperature, the strongest
heats of the furnace, and the abrasion of feeding and emptying.
Our customers are in almost every State of the Union, to all of
whom we refer

THOS. SMITH, Prest. AUGUST LAMBLA, Vice-Prest. & Sup

BALTIMORE

RETORT & FIRE BRICK CO.

MANUFACTORY AT

LOCUST POINT, BALTIMORE, MD.

Connection with the City by Telephone.

**Clay Retorts, Blocks & Tiles,
FIRE BRICK, FIRE CLAY,
AND FIRE CEMENT.**

Red and Buff Ornamental Tiles and Chim-
ney Tops. Drain and Sewer Pipe (from
2 to 30 inches). Baker Oven Tiles
12x12x2 and 10x10x2.

WALDO BROS., 88 WATER ST., BOSTON, MASS
Sole Agents the New England States.

EVENS & HOWARD,
 916 Market St., St. Louis. Mo.
 Works, Howard Station, Mo. Pacific R.R.

Fire Brick, Gas Retorts
 AND
RETORT SETTINGS.

Sewer Pipe, 3 to 24 in. diameter.
 Glass Pot Clay, Ground Fire Clay, in barrels and in bulk. All kinds of Fire Clay Goods.

Cincinnati Gas Retort & Fire Brick Works.
 —ESTABLISHED 1872.—

CHAS. TAYLOR,
 MANUFACTURER OF
Gas Retorts, Fire Brick, and Tile.
 Blast Furnace Linings, Cupola Blocks, Boiler Tiles, Grate Settings, and Stove Linings. Fire Cement, Fire Clay, Fire Sand, and all other Fire Clay Goods.

Branch Works, New Cumberland, W. Va.
 GENERAL OFFICE AND WORKS,
Burns St., Cincinnati, Ohio.

EMIL LENZ,
 2 & 4 Stone St., N. Y. City.
CLAY GAS RETORTS
 (ENAMELED.)

Fire Brick, Blocks & Tiles.
 FIRE CEMENT, RETORT ENAMEL, RETORT CEMENT, ETC., ETC.

Regenerative and Half-Regenerative Benches.
PORTLAND CEMENT.
 Correspondence Respectfully Solicited.

Bouton Foundry Co.,
 FOUNDERS AND MACHINISTS,
CHICAGO, ILL.

Gas Works Apparatus,
 PURIFIERS, CONDENSERS,
 Bench Work,
 SPECIALS, LAMP POSTS,
SCRUBBERS,
 Iron Roofs and Floors.

Plans and Estimates furnished for new works or extensions of old works.

PATENTS.
FRANKLIN H. HOUGH,
 Solicitor of American & Foreign Patents
 925 F. ST., WASHINGTON, D. C.
 (NEAR U. S. PATENT OFFICE.)

Personal attention given to the preparation and prosecution of applications for Letters Patent. All business before the U. S. Patent Office attended to for moderate fees. No Agency in the United States possesses superior facilities for obtaining Patents, or for ascertaining the patentability of inventions. Copies of patents furnished for 25 cents each. Correspondence solicited.



STEPHEN A. MORSE, President. M. B. DYOTT, Superintendent. EDWIN F. MORSE, Secretary. GODFREY REBMANN, Vice-Pres. CARLTON M. WILLIAMS, Treas.

STANDARD GAS LAMP CO.,

Office, 411 Cherry St. Factory, 1101, 1103 & 1105 Frankford Av.
Philadelphia, Pa.

It is to the interest of Gas Companies and Cities to use Dyott's Patent Champion Lamps, which give double the light with the same consumption of gas, and will save 50 per cent. over others in cost of keeping in repair. Gas Companies and others intending to erect Lamps of any description will do well to communicate with us. Special Drawings furnished and Estimates given on application upon Architects', Engineers' or our Draughtsmen's Plans.

Our Patent System of Instantaneously Lighting Gas (without electricity) for R. R. Depots is unequalled. Our High Candle Power Burner is superior to the Electric Light or any other High Candle Burner. We manufacture every description of Ornamental Lamps.

KLOENNE & BREDEL
IMPROVED REGENERATIVE FURNACES.

Self-Sealing Mouthpieces & Bridge-Pipes, Retort Houses,
WASHER-SCRUBBERS,
Gasholders, and Complete Gas Works.

Refers, by permission, to Mr. Eugene Vanderpool, of Newark, N. J.; Mr. E. G. Cowdery, of Milwaukee, Wis.; and Mr. Theo. Forstall, of Chicago, Ill. For further information apply to
FRED. BREDEL, 332 East 17th St., N. Y. City.

CHURCH'S REVERSIBLE TRAY



For Purifiers and Scrubbers.
 OVAL OR RECTANGULAR SLATS.
FOR LIME OR IRON SPONGE.
 MALLEABLE IRON CROSS BARS.
Strongest! Most Durable!
Most Easily Repaired!

Patented July 9, 1878, and Feb. 5, 1884.
 Used by the principal Companies in every State of the Union. Price List on application.

MANUFACTURED BY
JOHN CABOT,
 306 to 310 Eleventh Ave., N. Y. City.

MILLS' REVERSIBLE LIME TRAY,

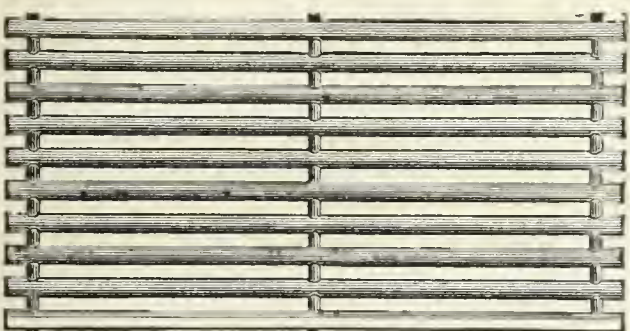

AND
WOODWORK
 Of Every Description
NEEDED BY GAS WORKS.

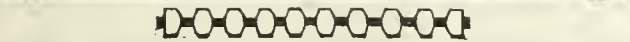

SEND FOR CIRCULAR AND PRICE LIST TO
GEORGE A. MILLS,
 Canton Av. & President St., Baltimore, Md.

Ferric Oxide for Gas Purification.

Ferric Oxide, as ground, screened, and prepared by me for purifying purposes, has now been in use for several years by many of the gas works throughout the country, including Detroit, Chicago, Milwaukee, East Saginaw, Burlington (Iowa), Ann Arbor, etc. It has proved, as I believe, the **Most Effective and Economical Agent** now in use. I am prepared to furnish the Oxide by the 100 lbs. or in car load lots, and will be pleased to give price f.o.b. cars at Ann Arbor or at place of destination. Address

S. H. DOUGLAS, Prest. Ann Arbor (Mich.) Gas Light Co.

GAS AND WATER PIPES.

GAS AND WATER PIPES.

ENGINEERS.

SAM'L R. SHIPLEY, Pres.
HENRY B. CHEW, Treas.

JAS. P. MICHELLON, Sec.
WM. SEXTON, Supt.

P. D. WANNER, Chairman. A. H. MELLERT, Sec. & Treas.

GLOUCESTER IRON WORKS,

GLOUCESTER CITY, N. J.

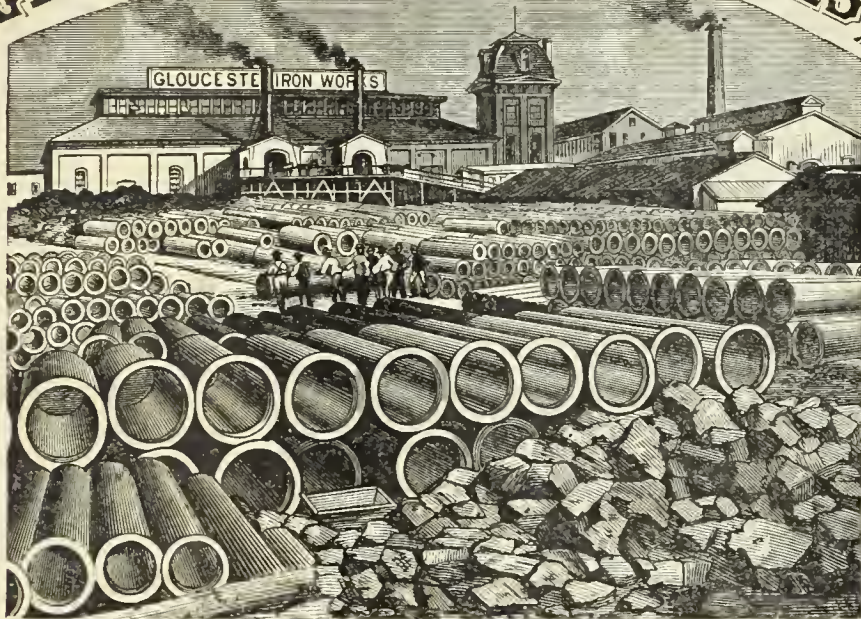

Cast Iron Gas & Water Pipes, Stop Valves, Fire Hydrants, Gasholders, &c.

Office No. 6 North Seventh Street, Philadelphia.

MATTHEW ADDY, President.

W. L. DAVIS, Selling Agent.

GEO. P. WILSHIRE, Sec. & Treas.

Cincinnati and Newport Iron and Pipe Company,

NEWPORT, KY.

Lamp Posts

AND

BENCH CASTINGS

A Specialty.

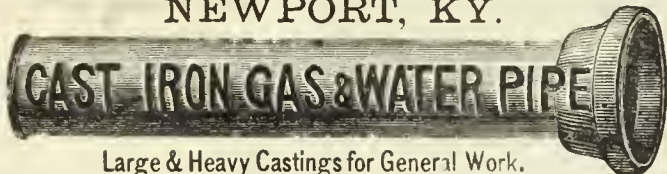

Branch

AND

SPECIAL CASTINGS

FOR GAS & WATER CO'S.

Large & Heavy Castings for General Work.

Manufacture Pipe from 2 to 48 inches. All work guaranteed first quality.

Pancoast & Rogers.

WROUGHT IRON PIPE,

VALVES AND GATES,

Cast Iron Gas & Water Pipe.

28 Platt and 15 Gold St., New York.

Parson's Steam Blower,

FOR IMPROVING BAD DRAUGHT IN BOILERS, AND FOR BURNING BREEZE OR OTHER WASTE MATERIAL.

PARSON'S TAR BURNER,

FOR UTILIZING COAL TAR AS FUEL.

PARSON'S AIR JET TUBE CLEANER,

FOR CLEANING BOILER TUBES.

These devices are all first-class. They will be sent to any responsible party for trial. No sale unless satisfactory. Manufactured by the WATERTOWN STEAM BLOWER COMPANY.

H. E. PARSON, Supt., 33 & 35 Liberty St., N.Y.

The Management of Small Gas Works.

By C. J. R. HUMPHREYS. Price, \$1.

A. M. CALLENDER & CO., 42 Pine St., N. Y.

MELLERT FOUNDRY & MACHINE CO., Ltd.

Reading, Pa.



Specials—Flange Pipe, Valves and Hydrants, Lamp Posts, Retorts, etc.

General Foundry and Machine Work.

JOHN FOX, Selling Agent. 160 Broadway, N.Y.

THE OHIO PIPE COMPANY,

MANUFACTURERS OF

Cast Iron Gas & Water Pipe,

BRANCH AND SPECIAL CASTINGS.

Gas-House Bench Castings, Hydraulics, Lamp Posts, Flange Pipe and Specials, Architectural Castings, Building Columns, Joists, Cellar Grates, Sash Weights, etc.

GENERAL FOUNDERS AND MACHINISTS.

Columbus, Ohio.

M. J. DRUMMOND,



SPECIAL CASTINGS AND LAMP POSTS.

Equitable Building, 120 Broadway, N. Y.

JOS. R. THOMAS, C.E.,

May be Consulted on all Matters Relating to Gas Works and Gas Manufacture.

ADDRESS THIS OFFICE.

WM. MOONEY

(Successor to WM. FARMER)

27 Pearl Street, N. Y. City.

(One door from Whitehall Street.)

CONTRACTOR FOR THE ERECTION OF GAS WORKS, OR APPARATUS OF ANY CAPACITY. AGENT FOR

WM. FARMER'S PATENTS.

Plans and Specifications Furnished.

WM. HENRY WHITE,

CONSULTING AND CONSTRUCTING

Gas Engineer & Contractor

Estimates, Plans, and Specifications furnished for new works or extensions of existing works.

No. 32 Pine Street, New York City.

Correspondence solicited.

WM. GARDNER, Gas Engineer,

Lewis Block, Room 20, Pittsburgh, Pa.

Those who intend to make alterations in existing gas plants, or who contemplate the erection of new works, will find it to their interest to open correspondence with the above. Plans made and estimates furnished.

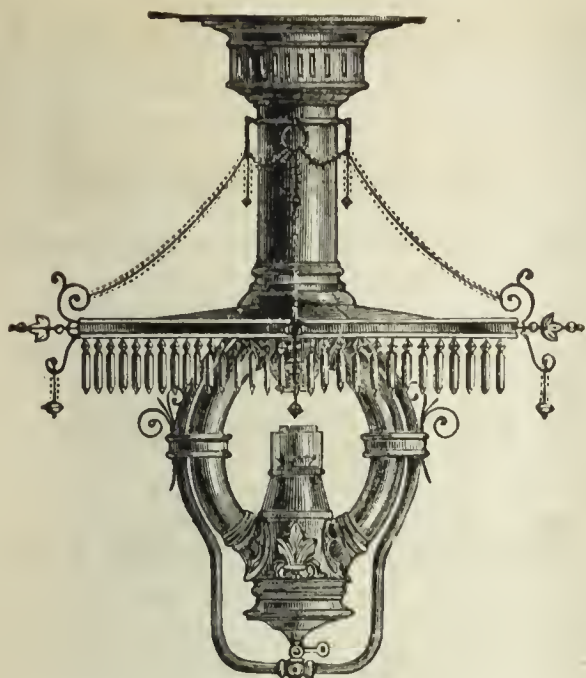

SIEMENS LAMP.

The Siemens and Lungren REGENERATIVE GAS LAMPS.

A System of Burning Gas whereby its Illuminating Power is Increased from 300 to 400 per ct. without the Expense, Trouble and Annoyance resulting from the use of Hydrocarbon Enriching Material.

The Siemens-Lungren Company received the only Silver Medal or Highest Award for Gas Burners at the "Novelties" Exhibition of the Franklin Institute, held at Phila., Oct., '85.

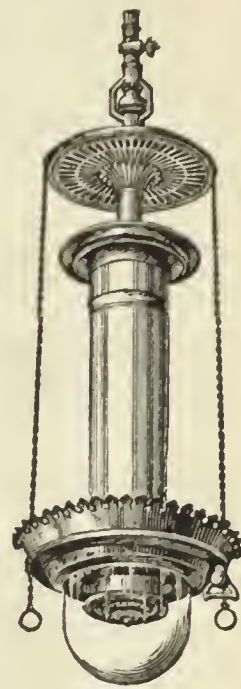

LUNGREN LAMP

THIRTEEN CANDLE POWER PER CUBIC FOOT OF GAS!

This result is obtained

SIMPLY BY THE SCIENTIFIC APPLICATION OF THE REGENERATIVE PRINCIPLE.

Consequently this largely increased illumination is always maintained without further cost and frequent attention

THE SIEMENS-LUNCREN COMPANY,

N. E. Cor. 21st. St. and Washington Av., Phila., Pa.

THE PATENT "STANDARD" WASHER-SCRUBBER

(KIRKHAM, HULETT & CHANDLER PATENT.)

Has been adopted by gas companies in all parts of the world. Between 300 and 400 companies, with the enormous daily output of over 300,000,000 cubic feet, are now using it. "Standard" Washer-Scrubbers have been erected for the following gas light companies since Jan. 1, 1886:

WALLASEY, ENGLAND.....	750,000	cubic feet.	RICHMOND, SURREY, ENGLAND.....	1,500,000	cubic feet.
NEWARK, ENGLAND.....	350,000	"	BRIDGEPORT, U. S.....	500,000	"
BUFFALO, U. S. (MUTUAL).....	500,000	"	TORONTO, CANADA.....	1,000,000	"
BERLIN, GERMANY.....	1,250,000	"	HARTFORD, U. S.....	1,000,000	"
SO. BRISBANE, AUSTRALIA.....	300,000	"	DETROIT, U. S.....	750,000	"
LEEDS, ENGLAND.....	2,000,000	"	SINGAPORE, CEYLON.....	300,000	"
FURTH, GERMANY.....	400,000	"	BRUNSWICK, GERMANY.....	300,000	"
FREIBURG, GERMANY.....	200,000	"	LILLE, FRANCE.....	750,000	"
NINE ELMS, LONDON.....	3,000,000	"	CADIZ, SPAIN.....	300,000	"
MELBOURNE, AUSTRALIA (2).....	3,000,000	"	READING, ENGLAND.....	2,000,000	"
GLUCKAUF COKE WORKS, GERMANY.	200,000	"	LINCOLN, U. S.....	250,000	"
BOURNEMOUTH, ENGLAND.....	1,000,000	"	ST. LOUIS, U. S. (LACLEDE).....	1,000,000	"
			BROOKLYN, U. S.....	2,000,000	"
			BROOKLYN, U. S. (NASSAU).....	1,000,000	"
			DENVER, U. S.....	1,000,000	"

That this apparatus is really the *standard* is indicated by the following names of important houses who represent this invention in the different countries of the world:

FRANCE & BELGIUM, Mons. J. A. Berly, 31 Rue Boindod, Paris. HOLLAND & DUTCH COLONIES, Mess. W. Hoven & Zoon, Rotterdam

GERMANY and AUSTRO-HUNGARY, Berlin-Anhaltische-Actiengesellschaft, Berlin, Moabit, and Dessau.

RUSSIA, Mr. F. Bley, Galernaya, 44, St. Petersburg. SPAIN, Mess. Nicolas, Chamon, Foiret & Cie., 29 Rue Claude-Vellefaux, Paris.

ITALY & MALTA, Sig. E. Canziani, 26 & 28 Portici, Vittorio Emmanuele, Genoa. Sig. Fratelli Scheuer, Via Chiaja, 124, Naples

NEW SOUTH WALES, Messrs. W. Coward & Sons, 143 Queen Victoria St., London.

NEW ZEALAND and VICTORIA, Messrs. G. D. Jennings & Co., 28 Gracechurch St., London.

Companies in the U. S. adopting this apparatus can now be assured of a market for the Ammoniacal Liquor at a remunerative price. Correspondence for purchase of "Standards" and Ammoniacal Liquor is solicited by the

GEO. SHEPARD PAGE, 69 WALL STREET, NEW YORK.

GAS WORKS APPARATUS AND CONSTRUCTION.

GAS WORKS APPARATUS AND CONSTRUCTION.

WORKS: { MILLVILLE, N. J.
FLORENCE, "
CAMDEN, "

R. D. WOOD & CO.,

OFFICES: { 400 CHESTNUT ST.,
PHILADELPHIA.

CAST-IRON PIPE 1½ to 72 Inches in Diameter.

Water Machinery and Gas Apparatus.

HEAVY CASTINGS.

HOLDERS,

LAMP POSTS,

VALVES,

PURIFIERS,

CONDENSERS,

BENCH WORK,

METER CASES.

FLOORS AND ROOFS,

FLANGED PIPE,

FIRE HYDRANTS,

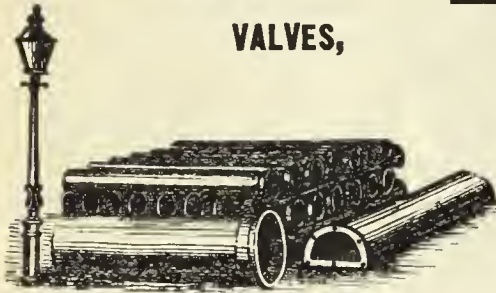

Estimates and Specifications for
NEW WORKS or EXTENSIONS
or ALTERATIONS of OLD ONES.

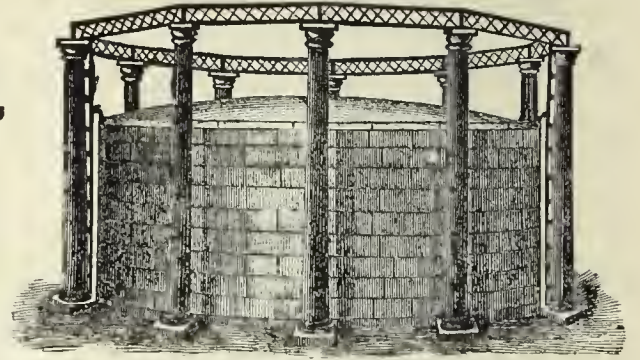

SOUTHWARK FOUNDRY AND MACHINE COMPANY,

Successors to MERRICK & SONS,

GAS APPARATUS,

Holder, Purifiers, Washers, Etc., Etc. Boiler and Tank Work. Steam Engines.
Hydraulic Machinery. Bessemer Plants, Etc.

Washington Ave. and Fifth Street, Philadelphia, Pa.

MORRIS, TASKER & CO.,

Limited,

Builders of Gas Works,

PHILADELPHIA PA.

GASHOLDERS, PURIFIERS, SCRUBBERS, CONDENSERS, EXHAUSTERS,

Bench Castings, Iron Roofs, Lamp Posts,

VALVES, STREET MAIN SPECIALS, ETC.,

MANUFACTURED BY

KERR MURRAY MANUFACTURING COMPANY.

From 1880 to 1886, inclusive, we erected Gasholders for the following cities, viz.:

Adrian, Mich.	East End Gas Co., Pitts-	Janesville, Wis.	New Castle, Pa.	Valparaiso, Ind.
Akron, Ohio.	burgh, Pa.	Johnstown, Pa.	Niagara Falls, N. Y.	Van Wert, Ohio.
Albuquerque, N. M.	East Saginaw, Mich.	Key West, Fla.	Osawatomie, Kans.	Wabash, Ind.
Altoona, Pa.	Elgin, Ills.	La Crosse, Wis.	Pittsburgh, Pa. (2)	Waco, Texas.
Anderson, Ind.	Evanston, Ills.	Lebanon, Ind.	Plainfield, Ind.	Waukesha, Wis.
Bellaire, Ohio.	Eufaula, Ala.	Lima, Ohio.	Portage City, Wis.	Wheeling, West Va.
Birmingham, Ala.	Frankfort, Ind.	Logan, Ohio.	Sedalia, Mo.	Wellington, Kans.
Bucyrus, Ohio.	Freeport, Ills.	Louisville, Ky.	Sheboygan, Wis.	West Pittsburgh, Pa.
Canton, Ohio.	Galesburg, Ills.	Mankato, Minn.	South Bend, Ind.	Xenia, Ohio.
Circleville, Ohio.	Grafton, West Va.	Mansfield, Ohio.	South Chicago, Ills.	Youngstown, Ohio.
Colorado Springs, Col.	Greensburg, Pa.	Marshalltown, Iowa.	Springfield, Ills.	Ypsilanti, Mich.
Danbury, Conn.	Huntington, Ind. (2)	Meridian, Miss.	Streator, Ills.	
Delaware, Ohio.	Ironton, Ohio.	Minneapolis, Minn.	Topeka, Kans.	
Delphos, Ohio.	Jamestown, N. Y.	Muskegon, Mich.	Uniontown, Pa.	

Under construction, 1887.

Arkansas City, Kans.	Grand Forks, Dakota.	Mobile, Ala.	Santa Fe, N. M.	Fuel Gas and Electric Engi-
Dallas, Texas.	Grand Rapids, Mich.	Pittsburgh, Pa.	Wichita, Kans.	neering Co., Pittsburgh, Pa.
El Paso, Texas.	La Crosse, Wis.	Pine Bluff, Ark.	Lexington, Mo.	Stillwater, Minn.

Estimates, with Plans and Specifications, for new or the rebuilding of old works, furnished on application.
Correspondence solicited. Address

KERR MURRAY MANUFACTURING CO.,

A. D. CRESSLER, General Manager.

FORT WAYNE, IND.

GAS WORKS APPARATUS AND CONSTRUCTION.

GAS WORKS APPARATUS AND CONSTRUCTION.

JAMES R. FLOYD,

(SUCCESSOR TO HERRING & FLOYD)

Oregon Iron Works,

531 to 543 West 20th St., N. Y.

Practical Builders of Gas Works,

MANUFACTURERS OF

ALL KINDS OF CASTINGS

AND

APPARATUS FOR GAS-WORKS.

BENCH CASTINGS

from benches of one to six Retorts each.

WASHERS: MULTITUBULAR AND AIR CONDENSERS; CONDENSERS; SCRUBBERS

(wet and dry), and

EXHAUSTERS

for relieving Retorts from pressure.

BENDS and BRANCHES

all sizes and description.

FLOYD'S PATENT

MALLEABLE RETORT LID.

PATENT

SELF-SEALING RETORT LIDS.

FARMER'S

PATENT BYE-PASS DIP-PIPE.

SABBATON'S PATENT

FURNACE DOOR AND FRAME.

BUTLER'S

COKE SCREENING SHOVELS.

GAS GOVERNORS,

and everything connected with well regulated Gas Works at low price, and in complete order.

SELLER'S CEMENT

for stopping leaks in Retorts.

N. B.—STOP VALVES from three to thirty inches—at very low prices.

Plans, Specifications, and Estimates furnished.

GAS vs. ELECTRIC LIGHT.

We would invite attention to the able and exhaustive argument of General A. Hickenlooper, President of the Cincinnati Gas Light and Coke Company, contained in a handsome pamphlet of 96 pages, entitled

"EDISON'S INCANDESCENT ELECTRIC LIGHTS FOR STREET ILLUMINATION. REPORT OF AN ARGUMENT DELIVERED BY A. HICKENLOOPER BEFORE THE COMMITTEE ON LIGHT, MUNICIPAL COUNCIL, CITY OF CINCINNATI, JULY 22, 1886."

This is a subject of special interest to all Gas Light Companies.

Prices.

25 copies..... \$7.50 100 copies..... \$22.50
50 copies..... 12.50 250 copies..... 50.00

A sample copy will be sent by mail on receipt of 50 cts.

A. M. CALLENDER, & CO., 42 PINE ST., N. Y. CITY.

THE CONTINENTAL IRON WORKS.

THOS. F. ROWLAND, Prest. WARREN E. HILL and CHAS. H. CORBETT, V.-Pres. THOS. F. ROWLAND, JR., Sec. & Treas.



GAS HOLDERS OF ANY MAGNITUDE.

P. O. Station G., BROOKLYN, N. Y.

ENGINEERS AND MANUFACTURERS OF

Gas Holders

CONDENSERS, SCRUBBERS, VALVES,

PURIFIERS, SELF-SEALING RETORT LIDS,

Hydraulic Mains,

And all other articles connected with the manufacture and distribution of Gas.

H. RANSHAW, Prest. & Mangr. WM. STACEY, Vice-Prest. T. H. BIRCH, Asst. Mangr. R. J. TARVIN, Sec. & Treas.

STACEY MFG. CO.,

MANUFACTURERS OF

Single and Telescopic Gasholders,

IRON ROOFS, BRIDGES, LAMP POSTS,

Water and Oil Tanks, Coal Elevator Cars,

COKE CRUSHERS, BENCH CASTINGS,

And all kinds of Wrought and Cast Iron Work used in the erection of Coal and Oil Gas Works. Rolling Mill Machinery and Heavy Castings a Specialty.

Foundry:

33, 35, 37 & 39 Mill Street.

Wrought Iron Works:

16, 18, 20, 22, 24 & 26 Ramsey Street.

Cincinnati, Ohio.

1842. **DEILY & FOWLER,** 1887.

Laurel Iron Works.

Address, No. 39 Laurel Street, Philadelphia, Pa.

MANUFACTURERS OF

GASHOLDERS,

Single or Telescopic, with Cast or Wrought Iron Guide Frames.

Holders Built Since 1881:

- | | | | | |
|-----------------------|---------------------------|---------------------------|-----------------------------|----------------------------|
| Seranton, Pa. (2d) | Hollidayshurg, Pa. | Jackson, Mich. | Montgomery, Ala. | New Castle, Pa. |
| West Point, N. Y. | Galveston, Texas (2d.) | Kalamazoo, Mich. (3d.) | Newport, R. I. | Long Island City, N. Y. |
| Fitchburgh, Mass. | Marlboro, Mass. | Glen Island, N. Y. | Portland, Oregon. | Macon, Ga. |
| New London, Conn. | Denver, Col. | Warren, Ohio. | Allegheny, Pa. (2d.) | York, Pa. |
| Derby, Conn. | Chicago, Ill. (West Side) | Bath, N. Y. | Atlanta, Ga. (2d.) | Chester, Pa. |
| Bridgeport, Conn. | Pittsburgh, Pa. (S. Side) | Lynn, Mass. | N. Y. City (Central Gas Co) | Hazleton, Pa. 2d.) |
| Allegheny, Pa. (1st.) | Pawtucket, R. I. | New Bedford, Mass. | Lynchburg, Va. (2d.) | Novelties Exhib. Phila |
| St. Hyacinth, Can. | Brookline, Mass. | Waterbury, Conn. | Saylesville, R. I. | Staten Island, N. Y. |
| Norwalk, O. | Sherbrooke, Can. | Deseronto, Can. | Rondout, N. Y. | Saugerties, N. Y. |
| Brattleboro, V | Burlington, N. J. (2d.) | Hoosie Falls, N. Y. (2d.) | Atlantic City, N. J. | Clinton, Mass. (Lan. Mills |
| Waltham, Mass. (2d.) | Bridgeton, N. J | Bethlenem, Pa. | Augusta, Ga. | Chattanooga, Tenn. |
| West Chester, Pa. | Bay City, Mich. | Atlanta, Ga. (1st.) | Waltham, Mass. (2) | Galveston, Texas. (3d.) |
| Baltimore, Md. | Erie, Pa. | Savannah, Ga. | Mahanoy Citv, Pa. | Omaha, Neb. |

SMITH & SAYRE MFG. COMPANY,

G. PORTER, Prest.

245 Broadway, N. Y.

CHAS. W. ISBELL, Sec'y.

Machinery & Apparatus for Gas Works

Drawings, Plans, and Estimates Furnished for the Improvement, Extension, or Alteration of Gas Works, or for the Construction of New Works.

Mackenzie's Patent Rotary and Steam Jet Gas Exhausters, Governors, Compensators, Condensers, Washers, Scrubbers. Isbell's Patent Automatic Street Pressure Governor, Gas and Water Valves, Hydraulic Main Dip Regulator, Bench Castings, etc. Purifying Boxes and "Standard" Scrubbers. Isbell's Patent Self-Sealing Retort Doors.

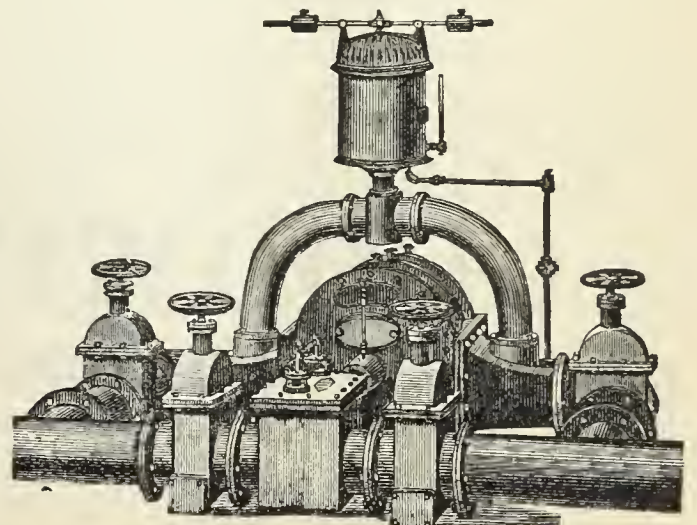

GAS COALS.

CANNEL COALS.

GAS ENRICHERS.

JAMES D. PERKINS.

PERKINS & CO.,

F. SEAVERNS.

General Sales Agents for

The Youghiogheny River Coal Company's

OCEAN MINE YOUGHIOGHENY GAS COAL.

The Coal from the Ocean Mine (recently operated by *Messrs. W. L. Scott & Co.*, of Erie, Pa.,) is now used by all the leading Gas Companies in the United States from Maine to Texas, and is recognized as *the only reliable Youghiogheny Gas Coal.* (See Map on p. 87 of this Journal, Feb. 16, '85.)

P. O. Box 3695,
New York.

PERKINS & CO., 228 and 229 N. Y. Produce Exchange.

BEAVER STREET
ENTRANCE.

BRECKENRIDGE CANNEL, OF KENTUCKY.

This Colliery was re-opened in June, 1886, since which date the Cannel has been delivered to over sixty of the leading Gas Companies in this country and in Europe. As an enricher ONE TON of this Cannel will do the work of TWO TONS of any other available Cannel, and is more economical than Naptha or Oil of any character. It can be delivered in parcels of one car load or more to any point in the United States or Canada.

(See AMERICAN GAS LIGHT JOURNAL, June 16, '86, pp. 346-7.)

P. O. Box 3695,
New York.

PERKINS & CO., 228 and 229 N. Y. Produce Exchange

BEAVER STREET
ENTRANCE.

JAMES & WILLIAM WOOD, Gas and Cannel Coal Contractors,

No. 40 St. Enoch Sq., Glasgow. No. 2 Talbot Court, London.

Proprietors of the BATHVILLE COLLIERIES (which produce the celebrated BOGHEAD CANNEL), Shields, Shieldmuir, Drumpeller, and other Collieries. This Firm offer

STANDARD CANNELS,

Unequaled as Gas Enrichers.

Analyses, prices, and all further information furnished on application to

Agency for U. S., Room 93, Nos. 2 & 4 Stone St., N.Y. City.

The Standard Oil Company,

REFINERS OF

NAPTHA AND GASOLINES.

ALSO MANUFACTURERS OF

A Special Grade of Naptha for Gas Companies

FOR ENRICHING COAL GAS.

Correspondence solicited.

No. 43 Euclid Avenue, Cleveland, Ohio.

To Gas Companies.

We make to order CAP BURNERS to burn any amount under a stated pressure. Send for samples.

Also, SERVICE CLEANERS, DRIP PUMPS, and STREET MAIN PROVING APPARATUS.

C. A. GEFROER,

248 N. 8th Street, Phila., Pa.

GOODWIN'S DIRECTORY

OF THE GAS LIGHT COMPANIES of the UNITED STATES & CANADA.

Price, \$10.00.

Orders may be sent to

A. M. CALLENDER & CO., No. 42 Pine Street, N. Y. City.

COKE CRUSHERS.

Newburgh Orrel Coal and Coke Co.

MINERS AND SHIPPERS OF

Mountain Brook Steam and Smithing Coals,

**NEWBURGH, PALATINE,
AURORA & TYRCONNELL
GAS COALS.**

Foundry & Crushed Coke Shipped Direct from Ovens
Mines Situated at
Newburgh, Flemington & Fairmont, W.Va.

HOME OFFICE,

33 S. Gay St., Baltimore.

CHAS. MACKALL, Gen. Mangr.

CHAS. W. HAYS, Agent in New York,

Room 147, WASHINGTON BUILDING, No. 1 Broadway.

Shipping wharves at Locust Point, Baltimore.

THE DESPARD COAL COMPANY

OFFER THEIR SUPERIOR

DESPARD COAL

To Gas Light Companies and Manufacturers of Fire Clay Goods
Throughout the Country.

ROUSSEL & HICKS, } AGENTS. { BANGS & HORTON,
71 Broadway, N. Y. } 16 Kilby St., Boston.

Mines in Harrison Co., West Va. Wharves, Locust Point, Balt.

Company's Office, 15 German St., Baltimore, Md.

Among the consumers of Despard Coal we name: Manhattan
Gas Light Co., N. Y.; Metropolitan Gas Light Co., N. Y.; Jersey
City, (N. J.) Gas Light Co.; Washington (D. C.) Gas Light Co.;
Portland (Maine) Gas Light Co. Reference to them is requested.

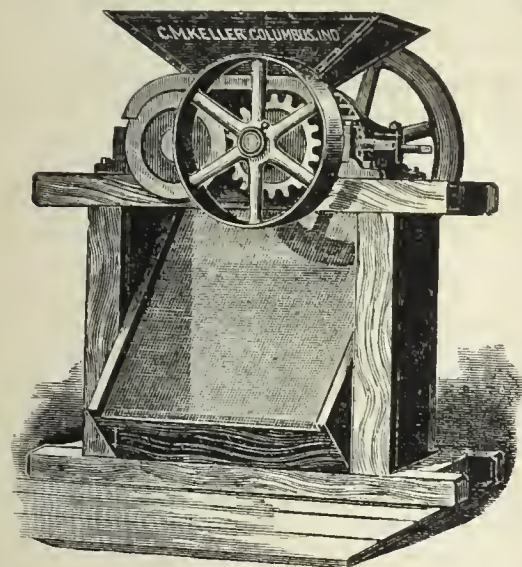

Keller's Adjustable Coke Crusher.

SIMPLE, STRONG, AND DURABLE.

C. M. Keller, Sec. & Supt. Gas Lt. & Coke Co. Columbus, Ind.

Correspondence Solicited.

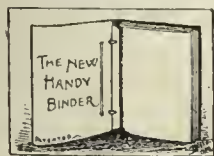

**THE NEW
HANDY BINDER.**

This article may be described as elegant
in appearance, strong, durable, and possessing many special
qualities of its own. It allows the opening of the pages per-
fectly flat, whether one or several numbers are in the binder.
Any number can be taken out and replaced without disturbing
the others. The papers are not mutilated for subsequent bind-
ing in permanent form. The binder is supplied with gilt side
title, and is an ornament to any desk or reading table. The
JOURNAL, filed in the Handy Binder, becomes a volume of great
value, always convenient for instant reference. Handy Binder.
Postage paid, \$1 00.

A. M. CALLENDER & CO., 42 Pine St., N. Y.

GAS COALS.

GAS COALS.

**THE
PENN GAS COAL CO.**

OFFER THEIR

Coal, Carefully Screened & Prepared for Gas Purposes.

Their Property is located in the Youghiogheny Coal Basin, near Irwin and Penn Stations on the
Pennsylvania Railroad, and on the Youghiogheny River.

Principal Office:

209 SOUTH THIRD STREET, PHILA., PA.

Points of Shipment:

Pennsylvania Railroad Piers; Greenwich Wharves, Delaware
River; Pier No. 1 (Lower Side), South Amboy, N. J.

Chesapeake & Ohio Railway Coal Agency,

FOR THE SALE OF THE

**Superior Kanawha Gas Coals, Cannelton Cannel,
Also, SPLINT AND STEAM COALS**

From the Kanawha and New River Regions, on the line of the Chesapeake & Ohio R'way.

C. B. ORCUTT, Sales Agent. | OFFICE, 150 BROADWAY, N Y

FRANCIS H. JACKSON, Prest. EDMUND H. MCCULLOUGH, V.-Prest. CHAS. F. GODSHALL, Treas H. C. ADAMS,

THE WESTMORELAND COAL CO.

Chartered 1854.

Mines situated on the Pennsylvania and the Baltimore
and Ohio Railroads, in Westmoreland County, Penn.

POINTS OF SHIPMENT:

PHILADELPHIA, BALTIMORE, SOUTH AMBOY, N. J.,
WATKINS (SENECA LAKE), N. Y.

Since the commencement of operations by this Company its well-known
Coal has been largely used by the Gas Companies of New England and the
Middle States, and its character is established as having no superior in gas
giving qualities, and in freedom from sulphur and other impurities.

Principal Office, 224 South 3d St., Phila., Pa.

A. M. SCOTT, PRESIDENT. A. DEMPSTER, C.E., SECRETARY. W. K. GILLESPIE, TREASURER.

MONONGAHELA AND PETERS CREEK GAS COAL CO.,

PRODUCERS OF

Coal Bluff Gas Coal.

MINES LOCATED ON THE MONONGAHELA DIVISION OF THE PENNSYLVANIA RR.,
IN THE CENTRAL PORTION OF THE PITTSBURGH COAL FIELD.

Points of Shipment—Buffalo, Cleveland, Erie, Chicago, New Orleans.

Since the introduction of Coal Bluff Gas Coal it has taken rank among the few first-class Gas Coals, and ac-
knowledges no superior in gas-giving qualities, ease of working, quality of coke, and freedom from impurities.

Milwaukee Agents, F. R. BUELL & CO., - - - Milwaukee, Wis.

General Office, 43 Sixth Ave., Pittsburgh, Pa.

GAS METERS.

GAS METERS.

GAS METERS.



INTERNATIONAL--1876--EXHIBITION.

The U. S. Centennial Commission

HAVE DECREED AN AWARD TO

HARRIS, GRIFFIN & CO.,

Twelfth and Brown Streets, Philadelphia, Pa. No. 49 Dey Street, N. Y. City, and No. 75 North Clinton Street, Chicago, Ill.

FOR THE FOLLOWING REASONS:

The Exhibit consists of a Series of METERS from the Largest Size Station Meters for the use of the MANUFACTURE OF GAS, to those for the use of the ORDINARY CONSUMER. The Instruments are WELL MADE, RELIABLE as to INDICATION, and embody a number of sundry improvements which, with the general character of the Exhibit, entitle the whole to commendation.

Attest—J. L. CAMPBELL,
Secretary, pro-tem.

Signed—A. T. GOSHORN,
Director General

J. B. HAWLEY,
President

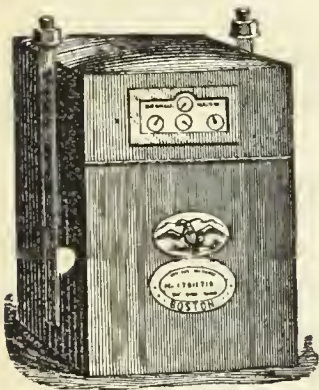

Dry Gas Meter.

With 39 years' experience and the best facilities for manufacturing, is enabled to furnish reliable work and answer orders promptly.

NATHANIEL TUFTS,

No. 153 Franklin Street, Boston, Mass.,

MANUFACTURER OF

DRY GAS METERS.

Station Meters of any Capacity.

Test and Experimental Meters, Pressure Registers, Pressure Gauges,
Pressure and Vacuum Gauges.

METER PROVERS, PHOTOMETERS, STREET LANTERNS, ETC., ETC.

Patent Cluster Lanterns for Street Illumination.

SCIENTIFIC BOOKS.

We are prepared to furnish to Gas Managers, and others interested in the topics treated of, the following books, at prices named:

KING'S TREATISE ON THE MANUFACTURE OF COAL GAS. Three vols.; \$10 per vol.	PRACTICAL TREATISE ON HEAT, by THOMAS BOX. Second edition. \$5.	THE GAS MANAGER IN THE LABORATORY, by a Practical Student. 8vo., Cloth. \$1.50.
GAS MANUFACTURE, by WILLIAM RICHARDS. 4to., with numerous Engravings and Plates, in Cloth binding. \$12.	GAS WORKS—THEIR ARRANGEMENT, CONSTRUCTION, PLANT, AND MACHINERY. \$8.	THE DOMESTIC USES OF COAL GAS, AS APPLIED TO LIGHTING, by W. SUGG. \$1.40.
THE GAS ANALYST'S MANUAL, by F. W. HARTLEY. \$2.50.	COAL; ITS HISTORY AND USE. by PROF. THORPE. \$3.50.	DISTILLATION OF COAL TAR AND AMMONIACAL LIQUOR by GEO. LUNGE. \$3.50.
TECHNICAL GAS ANALYSIS. \$2.80.	THE GAS WORKS OF LONDON, by COLBURN. 60 cents.	A TREATISE ON THE COMPARATIVE COMMERCIAL VALUES OF GAS COALS AND CANNELS, by D. A. GRAHAM 8vo., Cloth. \$3.
GAS MANAGER'S HANDBOOK, by THOS. NEWBIGGING. \$4.80.	THE GAS FITTER'S GUIDE, Showing the Principles and Practice of Lighting with Coal Gas, by JOHN ELDREDGE. 40 cents.	GAS AS A SOURCE OF LIGHT, HEAT, AND POWER, by C. J. R. HUMPHREYS. 10 cents.
GAS CONSUMER'S GUIDE. \$1.	GAS WORKS, AND MANUFACTURING COAL GAS, HUGHES. \$2.20.	GAS COMPANIES DIRECTORY. \$10.
A GUIDE TO GAS LIGHTING. 40 cents.	THE MANAGEMENT OF SMALL GAS WORKS, by C. J. R. HUMPHREYS. \$1.	GAS VERSUS ELECTRIC LIGHT. 50 cents.
GAS MEASUREMENT AND GAS METER TESTING, by F. W. HARTLEY. \$1.60	MANUAL FOR GAS ENGINEERING STUDENTS, by D. LEE, 40 cents.	PURIFICATION OF COAL GAS, by R. P. SPICE. 8vo. \$3.
GAS CONSUMER'S HANDBOOK, by WILLIAM RICHARDS, C.E.; 18mo., Sewed. 20 cents.	HOW TO MANAGE GAS, by F. WILKINS. Paper. 20 cents.	
A PRACTICAL TREATISE ON GAS AND VENTILATION with Special Relation to Illuminating, Heating, and Cooking by Gas, by E. E. PERKINS. \$1.25.		

The above will be forwarded by express, upon receipt of price. We take especial pains in securing and forwarding any other Works that may be desired, upon receipt of order. All remittances should be made by check, draft, or post office money order.

A. M. CALLENDER & CO., No. 42 Pine Street, New York.

KING'S TREATISE ON COAL GAS.

The most complete work on Coal Gas ever published. Three vols., bound \$30.

A. M. CALLENDER & CO., No. 42 Pine Street, New York.

GAS METERS.

GAS METERS.

GAS METERS.

GEO. J. MoGOURKEY, Pres. WM. H. MoFADDEN, Vice-Pres. (Phila.) WM. N. MILSTED, Gen. Supt. & Treas. (New York). WM. H. DOWN Sec.

AMERICAN METER COMPANY.

WET AND DRY GAS METERS.

PRESSURE REGISTERS.

METER PROVERS.

STATION METERS.

PRESSURE & VACUUM REGISTERS.

PORTABLE TEST METERS.

EXHAUSTER GOVERNORS.

PRESSURE & VACUUM GAUGES.

EXPERIMENTAL METERS.

DRY CENTRE VALVES.

CRESSON GAS REGULATORS.

AMMONIA TEST METERS.

GOVERNORS FOR GAS WORKS.

MARSLAND WATER METERS.

BAR AND JET PHOTOMETERS.

Manufactories:

512 W. 22d St., N. Y.
Arch & 22d Sts., Phila.

GAS STOVES,

SUGG'S "STANDARD" ARGAND BURNERS,
SUGG'S ILLUMINATING POWER METER,
Wet Meters, with Lizar's "Invariable Measuring" Drum.

Agencies:

177 Elm Street, Cincinnati.
244 & 246 N. Wells Street, Chicago.
810 North Second Street, St. Louis.
122 & 124 Sutter St., San Francisco.

HELME & McILHENNY,

(Successors to Harris & Brother. Established 1848.)

GAS METER MANUFACTURERS,

CONTINUE AS HERETOFORE AT THE OLD ESTABLISHMENT.

Nos. 1339 to 1349 Cherry Street, Philadelphia, Pa.,

To Manufacture Wet and Dry Gas Meters, Station Meters, Experimental Meters, Meter Provers, Center Seals, Pressure Registers
GOVERNORS, INDICATORS, PHOTOMETERS, & ALL OTHER KINDS OF APPARATUS FOR USE IN GAS WORKS.

From our long practical experience of the business, and from our personal supervision of all work, we can guarantee all orders to be executed promptly and in every respect satisfactorily.

WM. WALLACE GOODWIN, Prest. and Treas.

WM. H. MERRICK, V.-Prest.

S. L. JONES, Sec.

S. V. MERRICK, Supt.

THE GOODWIN GAS STOVE AND METER COMPANY,

Successors to W. W. GOODWIN & CO.

1012, 1014 and 1016 Filbert St., Phila., Pa. 142 Chambers St., New York.
76 Dearborn St., Chicago, Ill.

WALDO BROS., Agents, 88 Water St., Boston.

MANUFACTURERS OF THE "SUN DIAL" GAS STOVES, FOR COOKING AND HEATING PURPOSES.

Dry and Wet GAS METERS, Station Meters (Square, Cylindrical or in Staves) Glazed Meters, King's and Sugg's Experimental Met Lamp Post Meters, Etc., Etc., Meter Provers (sizes 2, 5 and 10 feet), Pressure Guages of all kinds, Pressure Registers, Pressure and Vacuum Registers, Pressure Indicators (sizes 4 inch, 6 inch and 9 inch), King's Pressure and Vacuum Gauges, Dry and Wet Centre Seals, Dry and Wet Governors, Exhauster Governors, Photometers of all descriptions. Lethby's Sulphur and Ammonia Test Apparatus complete—also Testing and Chemical Apparatus of all kinds, and of the most perfect description, for all purposes relating to Gas.

GOODWIN'S IMPROVED LOWE'S JET PHOTOMETER.

Agents for Bray's Patent Gas Burners and Lanterns.

Special attention to repairs of Meters, and all apparatus connected with the business.
All work guaranteed first class in every particular, and orders filled promptly.

G. B. EDWARDS, Mang'r, New York.
E. H. B. TWINING, Mang'r, Chicago.
Represented by S. S. STRATTON.

D. McDONALD & CO.,

GAS METER MANUFACTURERS.

(Established 1854.)

51 Lancaster St., Albany, N. Y. 34 & 36 West Monroe St., Chicago, Ill.

STATION METERS, EXPERIMENTAL METERS, METER PROVERS, PRESSURE & VACUUM REGISTERS, PRESSURE GAUGES, ETC.

Also STAR GAS STOVES, RANGES, and HEATING STOVES.

We use only the very best materials, and employ the most skilled labor, and by our long experience (32 years) and personal supervision of every detail, we feel justified in assuring the public that our goods will give perfect satisfaction. Every Meter emanating from our establishment will bear the State Inspector's Badge, and will be fully warranted by us. Our Annual and Calendar will be sent to Gas Companies upon application.

GAS ENGINES.

GAS ENGINES.

GAS ENGINES.

THE "OTTO" GAS ENGINE.

Guaranteed to Consume 25 to 75 ANY OTHER GAS ENGINE
Per Cent. LESS GAS than DOING THE SAME WORK.

TWIN ENGINES Impulse every revolution.
THE STEADIEST RUNNING GAS ENGINE YET MADE.

ENCINES AND PUMPS COMBINED,

For Hydraulic Elevators, Town Water Supply, or Railway Service.

Special Engines for Electric Light Work.

OVER 15,000
IN USE.

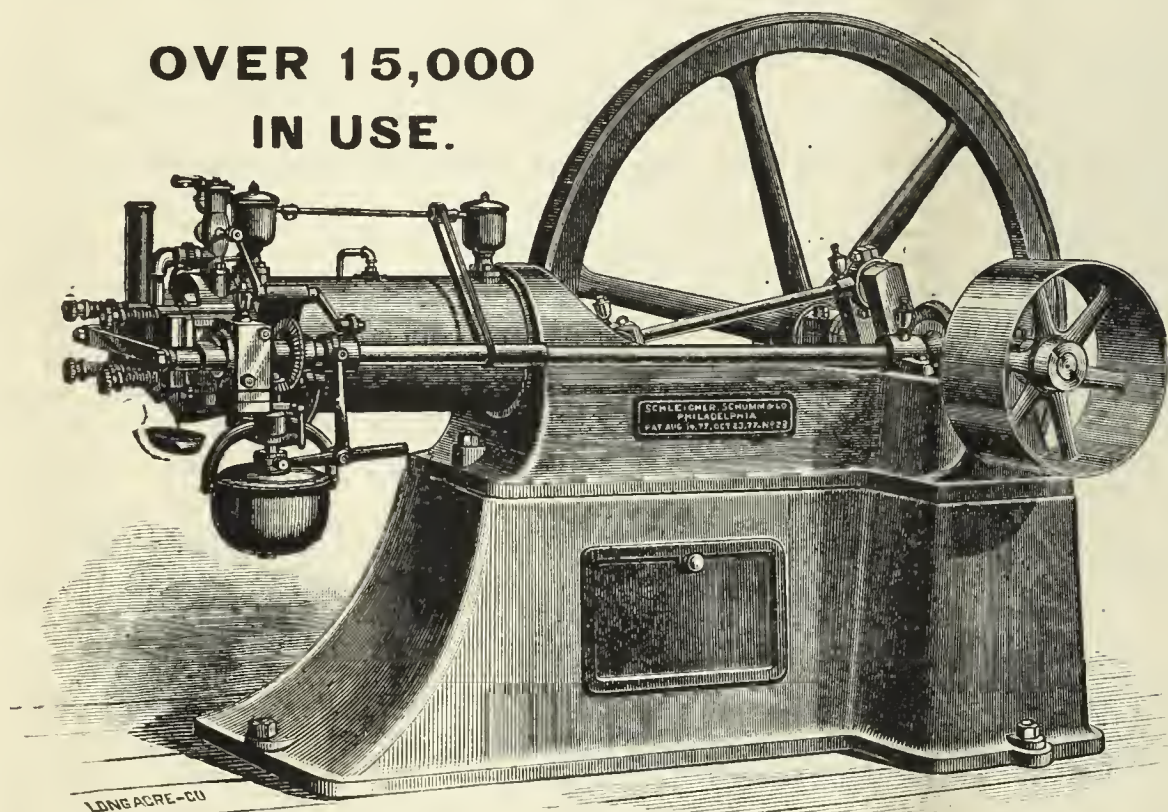

The Otto Gas Engine is now consuming, at a moderate computation, 2000 millions cubic feet of gas per year, nearly all of which is furnished during day time only.

**THE ONLY HIGHEST AWARD, ONLY GOLD MEDAL,
AT ELECTRICAL EXHIBITION, PARIS, 1881.**

MADE IN SIZES FROM 1 TO 25 HP. INDICATED.

FOR PARTICULARS, PRICES, ETC., APPLY TO

SCHLEICHER, SCHUMM & CO.,

Works:

Branch Office:

N E. Cor. 33d & Walnut Sts., Phila., Pa.

130 Washington Street, Chicago, Ill.

THE AMERICAN

GAS LIGHT JOURNAL

REDMAN & KENNY, N. Y.

PUBLISHING OFFICE No. 42 PINE STREET

DEVOTED TO THE INTERESTS OF ILLUMINATION, VENTILATION, WATER SUPPLY AND DISTRIBUTION, & GENERAL SCIENCE.

VOLUME XLVII.—No. 5.
Whole No. 677.

NEW YORK, FRIDAY, SEPTEMBER 2, 1887.

{ \$3 PER ANNUM,
IN ADVANCE.

A. M. CALLENDER & CO., Proprietors. C. E. SANDERSON, Manager.
JOS. R. THOMAS, C. E., Editor. T. J. CUNNINGHAM, Asst. Editor.

ENTERED AT THE POST OFFICE AT NEW YORK, N. Y.
AS SECOND CLASS MATTER.

Published on the 2d and 16th of each month, at No. 42 Pine Street, N. Y.

Terms of Subscription, Including Postage.—For the United States and Canada, \$3 per annum. European countries, \$3.50 (15 shillings—18 francs). All payments to be made in advance. Single copies, 15 cents.

Remittances should be made either by post-office order, registered letter, or bank draft on New York, payable to the order of A. M. Callender & Co.

Correspondence.—Wishing to make this JOURNAL a gazette of intelligent discussion to those of our readers who may wish to gain or give information on the subjects to which its columns are devoted, correspondence is solicited for publication from all who make the study of those subjects a pleasure or a profession.

The American News Company, Nos. 39 and 41 Chambers street, New York, are agents for this JOURNAL. Newsdealers will send orders to them.

Collections are invariably made directly from this office, for subscriptions, advertisements, etc. We have agents to solicit the same, but they are not authorized to receipt for money.

Books.—We will forward by express, at publisher's lowest rates, any book—scientific or otherwise—to any address in the United States or Canada. No books will be sent C. O. D.

CONTENTS.

An Asterisk (*) denotes an illustrated article.

EDITORIALS—

The Decision of the Dayton (Ohio) City Council.....	129
Personal Mention, and Corporate Luck.....	130
Notes from the West, by "Retort".....	130
Papers Read at the Recent Meeting of the British Gas Institute.....	131
* The Guide Framing of Gasholders, by W. H. Y. Webber.	
The Pyro-Magnetic Dynamo—Summary of a Paper by T. A. Edison	136
Special English Correspondence.....	137

Coke and Breeze as Boiler Fuels—Mr. Lewis T. Wright Lectures on Coal Gas—A Remarkable Accident—Mr. Magnus Ohren and the Sulphur Compounds—The Accounts of the Gas Light and Coke Company.

Dr. Flock's Experiments on Coal Oil Lamps.....	138
--	-----

ITEMS OF INTEREST FROM VARIOUS LOCALITIES..... 138

To Furnish Electric Light—In Disgrace—Changes at St. Paul, Minn.—The Jarvis System Adopted at Lawrence, Mass.—Water, and Gas, too, for Sanford, Me.—The Artificial Lighting Industry of Norristown, Pa.—Georgetown, Col., Chooses Gas—New Gas Company—What is the Matter with the Local Rulers of Fort Madison, Iowa?—Something Worth Remembering—To Enlarge the Works—The Keller Coke Crusher—Western Waifs, by "Diaphragm"—Securing Control—Cheaper Gas for Poughkeepsie, N. Y.—Not New to the New Orleans, La., Gas Light Company—Almost Ready—Allegheny County (Pa.) Gas Receipts—Leased—The Parkinson Three-Partition Drum Gas Meter—Improvements at North Adams, Mass.—Bro. Gilbert Comes Down Once More—Formation of a Construction Company—Bonded—Progress at Columbus, Ohio—Changed Hands—Public Lighting at Bath, Me.—Killed by the Electric Current—Poor Reno, Nev.—Cheaper Gas for Chattanooga, Tenn.—Consolidated—Bonding the Washington (D. C.) Gas Light Company—Trouble over Meter Rent Charges, etc.—At the New Hampshire State House.

Regulating the Speed of Engines for Driving Dynamos	141
Generator Furnaces for Small Gas Works.....	141
Painting Ironwork.....	142
The Market for Gas Securities.....	142

THE DECISION OF THE DAYTON (OHIO) CITY COUNCIL.

Our Western correspondent, "Retort," in his current letter to the JOURNAL, briefly mentions the fact that the City Council of Dayton, Ohio, has refused to grant an opposition gas franchise to those who figured as the nominal organizers of the incorporation known as "The Merchants National Gas and Fuel Company;" but, believing that the action of the Council merits a somewhat more extended notice, we herewith present a summary of the proceedings of the meeting at which the petitioners' plaint was rejected.

The inciting cause for the organization of the Merchants' Company scheme, if the assertions of its projectors are to be deemed worthy of believe, was the usual desire to furnish the local residents with good gas at a cheaper rate than that charged by the existing Company. It seems really to be misuse of space and a waste of ink to mention the "inciting causes" of this and similar opposition movements; and in order that hereafter we may, when referring to operations of the sort, keep the space and save the ink, we shall expect our readers to remember the stereotyped claims which invariably preface the handing-in of a petition to any and all Councils for the privilege to operate an opposition gas works. Now (in order to determine whether the Merchants' Company sponserers had any real foundation for their burning desire "to supply a cheaper and better gas" than that already supplied in Dayton), we submit that the Daytonites had not much cause for complaint in respect of the service rendered them by the old Dayton Gas Light Company. And our impression we think will be shared in by the fraternity, who, through the columns of our issue for April 16 last, were informed that some days prior to the 1st day of that month the Dayton Company's Board of Directors caused the publication of the following announcement: "Resolved, That on and after April 1, 1887, the price of gas be reduced to \$1.25 per thousand cubic feet, and a discount of 10 cents per thousand cubic feet be allowed on all bills paid at the office of the Company on or before the 5th of the month." It goes without saying that a net rate of \$1.15 per thousand cubic feet means even more than a reasonably cheap gas service for a city situated like Dayton, and we are not aware that any well-founded complaint was made against the illuminating power of the gas supplied. In fact, if memory does not betray us, the lighting power of the Dayton Gas Company's product approximates closely to an average of 19 candles, which value will compare favorably with that sent out by any other Ohio Company. Further, a well-finished 19-candle gas will better answer the requirements of the consumer, let the latter be located where he may, than any of the so-called 25-candle power gases over which so much talk has been wasted.

Prior to the April reduction the Dayton Company's gross rate was fixed at \$1.50 per thousand, but by means of a liberal system of discounts the average net figure paid by the people was probably not in excess of \$1.35 per thousand. These things all go to prove the falsity of the stock-trade arguments of the Merchants' Company projectors, and we are pleased to say that the fairness of the policy pursued by the old Company was not entirely forgotten by those most potent in the government of the city. When the nature of the application was being considered by Council (the petitioners asked for a decidedly broad franchise) it was suggested that, as the applicants claimed to be properly and legally in

corporated and organized, and the stock had been subscribed for, they would allow a special committee of the Council the right to examine the books of the Company. A committee of that nature was appointed, the members whereof subsequently reported their inability to find out anything specific about the matters which had been relegated to them for investigation. The report, in substance, was something like this: When the committee put the question to the reputed organizers the latter replied that there were 18 stockholders who held \$150,000 of the entire capital (\$200,000) amongst them, and that others stood ready to subscribe for the balance, "when the ordinance was passed;" but that they (the organizers) would neither reveal names nor would they produce any books. Now, if the reputed progenitors of a "Merchants' Company" were engaged in a *bona fide* effort we fail to understand why they should object to making public such simple "secrets" as those that were sought after by the inquiring committee of the Council. If they were backed by the Dayton merchants, would not the broadcast publication of that fact help their cause rather than injure it? Whether harm or help accrued to their cause by reason of their unwillingness to act in other than a peculiarly mystifying manner, we are unable to say, but the certainty remains that, shortly after the reception of the committee's report, the Council decided, by a vote of 12 to 4, to reject the petition and refuse the franchise. In the future, then, the owners and managers of the Dayton Gas Light Company will be allowed to reap the fruit of their investment and toil.

In closing our reference to this affair we might add that much stress was placed on the fact that the Merchants' Company (it was organized by non-residents) would bring much "foreign capital" to Dayton, in response to which prattle the Dayton *Journal* replied: "A franchise of the streets of Dayton, owned by foreign capitalists, will prove a perpetual depletion of our home capital. Instead of being advantageous to the people it would be a constant drain upon their resources for the benefit of foreign capital." Yes; foreign capital ever manages to extract domestic compensation.

PERSONAL MENTION AND CORPORATE LUCK.

The Associated Press despatches of August 18 gave the details of a railroad accident that occurred to passenger train No. 8 of the Pittsburgh, Fort Wayne and Chicago Railroad at an early hour of that date. Close by a place known as Byand station, which is some 12 miles east of Alliance, Ohio, the rear sleeper of the swiftly moving train was thrown from the track—owing, it is said, to the spreading of the rails—and several passengers received severe injuries. The sufferers included a well-known member of the gas fraternity, Mr. W. H. Denniston, of the East End Gas Company, of Pittsburgh, Pa., who is also Chairman of the American Gas Improvement Company, of the same city. Mr. Denniston was badly shaken up, and although he escaped fatal injury, the nature of the bruises received obliged the sufferer to remain perfectly quiet for several days. We are more than pleased, however, to announce that he is able to move about again, although frequent twinges remind him of his narrow escape from a frightful death. The car occupied by Mr. Denniston contained two other passengers and the usual porter. Of these, the latter was instantly killed, and the other inmates received injuries of a most severe character. Taking everything into consideration the Pittsburgh gas man has much to be thankful for, and his brethren can but rejoice with him over his fortunate escape.

Mentioning this occurrence puts us in mind that misfortune is said never to come singly, and perhaps the American Gas Improvement Company is at present inclined to side with the originator of that ancient proverb. First, we have the serious accident to its Chairman; second, the principal office of the Company came within one of being destroyed in the disastrous fire that occurred on 5th street, Pittsburgh, about a fortnight ago; and finally, its Secretary, Mr. J. M. Critchlow, while returning home from a business trip to St. Louis, met with rough treatment at the hands of some sleeping car thief. While sound asleep in a Pullman car berth the "knights of the road" managed to deprive him of a valuable watch and chain, a considerable sum in cash, and \$7,500 in drafts and checks. The latter, however, did not avail them much, since the "paper was not negotiable." The Company, nevertheless keeps on in the even tenor of its way, for we note that at its recent annual meeting (held last Saturday) the former board of officers was re-elected, and a semi-annual dividend of 6 per cent. was declared. Thus it would seem, after all, that the cumulus which overshadowed the Company and its officers was lined with silver.

Mr. Geo. A. McIlhenny, President of the Washington (D. C.) Gas Light Company, has suffered severely this summer from an attack of

malarial fever. We are rejoiced to say that his condition improves daily, and are constrained to add that if ever there was a hero Mr. McIlhenny is one.

The fraternity will be pleased to hear that Mr. W. W. Goodwin is rapidly recovering from the severe illness that caused his friends so much uneasiness. May many years of activity be his portion.

Notes from the West.

By RETORT.

AUGUST 27, 1887.

The Canton (Ohio) Gas Light and Coke Company has increased its capital stock from \$55,000 to \$150,000.

The Owensboro (Ky.) Gas Company has sold its plant and franchise to the Southern Illuminating Company, of Louisville, Ky., and the new proprietors will introduce a water gas plant. The price obtained for the stock was 75, realizing \$16,500.

At the annual meeting of the stockholders of the Toledo (Ohio) Electric Light Company, held in January last, the long standing differences of opinion that existed between rival factions of the concern developed into an open quarrel, which resulted in the election of two boards of directors and a double list of officers. The affair, quite naturally, resulted disastrously for the Company, and the property was finally advertised for sale by the Sheriff. The approach of the date of sale necessitated immediate action on the part of the local stockholders, who have applied for a receiver.

A few days ago it was announced through the press that James M. Clark *et al*, of Cincinnati, Ohio, had sued the Findlay (O.) Gas Light Company for \$100,000 damages because of the failure of the latter to fulfill a bargain made for the sale of the famous Karg and other gas wells belonging to the Company. The announcement seems to have been premature, as investigation discloses the fact that Clark failed to make the necessary deposit (\$45) to secure the costs, as required by the County Clerk. Hence the case seems to be "hung up."

The City Council of Topeka, Kansas, has refused to renew its contract with Bro. Chollar, and has contracted with the Brush Electric Light Company to light its streets with the tower system. The Brush folks will erect eight towers, each 150 feet high, at such points in the city as the Council may designate, and for the sum of \$9,000 per year keep burning on each tower four electric lights of 2,000-candle power each all night, on each night of the year, for a period of three years.

The city is to grant the Company the use of the tower on Kansas avenue. All other towers are to be erected at the Company's expense.

The gas war in Uncle Joe Light's district is over, and appearances indicate that the Dayton (O.) Gas Light Company is on top. The opposition came before the City Council under the name of "The Merchants' National Gas Company," and asked for the right to enter the streets, alleys, etc., in consideration of cheap gas. The ordinance was referred to a special committee who reported in favor of the ordinance—with certain conditions, however, compelling the new company to cover with its mains the same territory as that operated in by the old Company, and prohibiting any transfer of franchise or consolidation. That ordinance, if passed, would compel the new Company to become a genuine competitor, with a maximum charge for gas of \$1.15 per thousand. It is not surprising, therefore, to hear that the ordinance was defeated at the next meeting of the Council.

A new departure seems to have been taken at Bellevue, Ky., where they have established a water gas plant, and propose to manufacture a fuel gas and use the same for illuminating purposes, on the principle of incandescent gas lighting. The Company was given a 25-year franchise, and receives \$25 per year for its street lights.

The works have a daily capacity of 150,000 cubic feet. For illumination light is to be obtained by using a magnesia comb—which forms the principal feature of a Swedish patent—and it can only be employed with gas made by this particular process. The price for gas will be 50 cents per thousand cubic feet. The Company claims that at that figure the gas is cheaper than coal for fuel; and that a thousand feet of it is equal in candle power (used in the patent burner) to a thousand feet of ordinary coal gas. Perhaps Bro. Salter, who lives only a couple of miles away, or Bro. Fullagar, who is just across the river, could be persuaded to visit the Bellevue works, and write the matter up for the JOURNAL.

[Reprinted from the London Journal.]

Papers Read at the Recent Meeting of the British Gas Institute.

Mr. W. H. Y. Webber, of London, read the following paper on

THE GUIDE FRAMING OF GASHOLDERS.

The subject of the stability of gasholders, and the determination of the forces that tend to disturb this necessary quality in such structures, has occupied the attention of the foremost gas engineers of the age in this and other countries; and it may therefore appear presumptuous in the writer to ask the members of the Gas Institute to follow him in a critical review of the principles concerned in this important problem, which has for its avowed object the suggestion and maintenance of a fresh hypothesis calculated to seriously modify the elements of future gasholder design. In order to avoid this reproach, therefore, it may be well to premise that in what follows there is no intention to dogmatize, but only to put forward certain observations which appear to the writer to arise from reflection upon observed facts, and which may or may not bear practical fruit in abler hands on a future day.

The object of this paper is, in brief, to investigate the principle upon which the guide framing of gasholders has hitherto been constructed, in order to determine what office is filled by this part of gasholder structures, and how it fulfills its purpose. With this idea the writer proposes to review the existing theory and practice upon the general subject, and upon this review to base the suggestion for a new departure.

It may facilitate, at the commencement, the understanding by the meeting of the writer's intention if it is stated at once that the purpose of this paper is to show that the ordinary guide framing of gasholders may be safely dispensed with, and its place supplied by a system of guiding from the base, which may be shortly described as a development by duplication of the bottom curb and rollers. It is evident that if the lofty framework now generally considered necessary for guiding holders up and down their vertical course could be done without, a very considerable economy will result. The standing guide framing is not only costly and troublesome to erect; it also takes a long time to put together and adjust, and ever after requires annual outlay for painting. If the teaching of this paper is accepted there will be no trouble on this score, and the sole provision for guiding and maintaining the stability of a holder will be the rollers on the outer lift working against guides in the tank, and only carried by short piers or brackets to the height of 5 or 6 feet above the water line. If the writer's suggestions do not upon examination commend themselves to the better judgment of members of the Institute, it is hoped that the general review of the actualities of gasholder construction, and the observations thereupon which may be made upon this occasion, will, after all, prove to have not unworthily occupied the meeting.

The difficulty of this question of gasholder stability has been acknowledged by the highest authorities. M. Arson, the learned Chief Engineer of the Paris Gas Company (whose memoir upon gasholder construction, prepared for the French Society of Civil Engineers, and translated by Dr. W. Pole, F.R.S., will be found in the second volume of "King's Treatise on Coal Gas"), admits in this classical work, under the section "Guides," that the stability of the bell of a gasholder constitutes a problem as difficult to realize as it is important to solve. And Mr. Benjamin Baker, M. Inst. C.E.—an engineer in whom facility in mathematics and practical experience are remarkably combined—declares, in his report upon Mr. George Livesey's first three-lift holder, that "the gasholder under consideration is one of that class of structures in which it is impossible to foresee the exact intensity and nature of the stresses." Thus it is that when an engineer, having to design a gasholder with its framing, wishes to go to work in a rational manner—that is to say, to attain his objects with the least possible outlay for material and labor—he finds himself confronted at the outset with an exasperating uncertainty respecting the value and effect of the stresses for which he has to provide.

The writer's attention has been occupied with this subject for many years—first as a matter of professional duty, and latterly, perhaps, because of the fascination which the unknown rarely fails to exert upon those who have once come face to face with it. He has seen holders wrecked that should have been standing to this hour, and he knows of holders still standing and doing good service that ought, according to rule, to have been blown down fifty times over. The latter are like the proverbial cab horse, that cannot fall down and die because he is bitted and harnessed up so tight. So with these everlasting holders; they stand simply because they cannot help it—or, as this may seem a very unscientific explanation of the facts, they stand perhaps by virtue of some overlooked factor of stability, or because they have never been sub-

jected to such destructive stresses as are supposed to be inevitable for such structures.

Investigation into this question can only take one course—first, to ascertain the nature and amount of the forces which a gasholder must withstand; secondly, to determine how these stresses may best be met. In the first place, therefore, we have to realize the conditions of a gasholder—a cylindrical iron vessel with a cover, required to float in water with its lower open edge downward. Hence the vessel is in unstable equilibrium. M. Arson says truly, "the center of gravity of the bell is much above its center of figure * * * and it tends to topple over as soon as the two centers cease to be maintained in the same vertical line." Neither M. Arson, however, nor any other writer upon this subject, has thought it necessary to compute the natural overturning moment of a gasholder, for the sufficient reason that the conditions of its usefulness require that this force should be kept *nil*—that is to say, that every gasholder, to be a holder at all, must be so guided at all possible altitudes that the center of gravity and the axis, or center of figure, shall be always in a vertical line. If this condition is seriously disturbed, swift destruction of holder and framing together must ensue. So long as the balance is maintained, however, the tendency to topple over remains a tendency rather than an active force. It is nothing until the rising of the holder brings the center of gravity above the water line, after which it progressively increases, attaining its maximum when the holder is full. Although we may not require to compute the overturning moment of a holder due to its form and condition, we must not ignore it, as Mr. Arson and those who have followed him have done.

Besides this inherent tendency to capsize, a holder may be blown over by the wind. How much pressure wind may be reasonably expected to exert against a gasholder is not by any means a settled and agreed quantity. According to some engineers and meteorologists, any exposed structure in this country may have to withstand a wind pressure of 56 pounds per square foot, and even more. This figure is the Board of Trade Committee's maximum. Mr. B. Baker, however, whose experiments and observations upon wind pressure at the Forth Bridge works and elsewhere have thrown much light upon this obscure question, is doubtful whether an actual wind storm averaging 20 lbs. per square foot over any considerable area has ever occurred in this country. Mr. Baker has declared his disbelief that the Old Kent Road three-lift holder will ever be exposed to one-third of the assumed wind pressure of 40 lbs. per square foot. It is true that the anemometer at the Greenwich Observatory has stopped registering at an indicated pressure of 51 lbs. per square foot; and a King's gauge at the Old Kent Road works has been observed by Mr. Livesey to register a pressure of 26 lbs. per square foot. Where these extreme velocities are credited, however, they are always admitted to be momentary in duration and limited in area. Mr. Baker, moreover, has demonstrated the fallacy of instrumental indications of wind pressure by producing an index effect of 65 lbs. with an actual sudden gust of 20 lbs. per square foot. Mr. C. Shaler Smith, an American engineer, who has made a special study of the effects of tornadoes (inspecting examples of damage from wind—such as vehicles overturned, walls thrown down, etc.—and computing the force necessary in every case to produce the observed effect), states that a maximum of 30 lbs. per square foot is the utmost that need be allowed for. In view of these considerations, it will therefore be fair to assume that a pressure of 20 lbs. to the square foot is the greatest actual force that wind is likely to exert over the whole exposed surface of a gasholder erected anywhere in the United Kingdom.

Then we have to determine how much of the force of wind stated with reference to impact upon a vertical plane can take effect upon a cylindrical gasholder with shallow domed top. Mr. Baker takes 41 per cent.; Mr. Arson admits 46 per cent.; the highest estimate is 57 per cent. Taking the resistance of the top into consideration, it will probably be a near approximation to take 50 per cent. of the area of vertical cross-section of a gasholder as representing the actual equivalent plane exposed to the wind. This is the same thing as multiplying the diameter and height and this product by 10 for the maximum wind pressure on a holder.

Now comes the question—How is this pressure exerted? M. Arson and all his followers have taken this total stress as being divided, first among as many guide columns as the rollers on the holder bear against at one time, and then among the points of contact with these guides, as counted in the tiers of rollers. Thus, supposing any two columns or vertical lines of guidance to uphold a telescopic holder 100 ft. by 50 ft., we should say, according to these principles of calculating, that the total wind stress on such a holder is $100 \times 50 \times 10 = 50,000$ lbs., which is taken by two vertical guides, each of which therefore sustains a thrust of 25,000 lbs., divided equally among the top, middle, and bottom rollers;

the thrust at every point being therefore 8,333.33 lbs. Then all we should have to do would be to make our uprights strong enough to sustain this pressure applied with leverages (in the two upper tiers of rollers) of 50 ft. and 25 ft. respectively above the point of attachment of the column and standards at the base, and the problem is solved. It is very simple, but, in the writer's opinion, altogether wrong.

There is no justification whatever for the assumption that wind pressure tends to push a gasholder *bodily along a horizontal plane*—which is the hypothesis underlying this system of computing the strength necessary to uphold a holder. Test this hypothesis by the method of reduction. If the wind pressure can be equally divided among any number of horizontal tiers of guide rollers, we need only make them strong enough and we can diminish their number to two (fig. 1), or even to one.

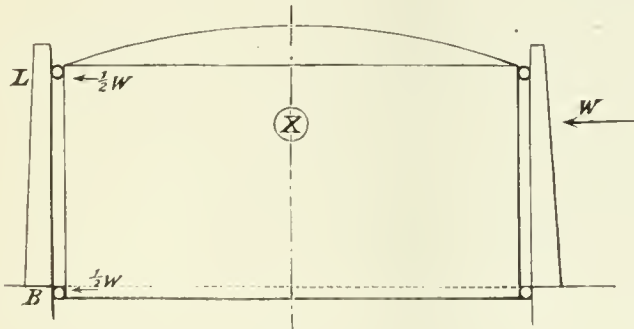

Fig. 1.

Thus, in the example cited, the 25,000 lbs. on a vertical guide, instead of being divided among three tiers of rollers, might be made 12,500 lbs. upon each of two rollers, or the whole 25,000 lbs. might be concentrated upon one roller—it is only as much weight as comes upon a locomotive engine wheel every day; and we could easily provide a sufficiently strong horizontal abutment to resist it. You do not want me to show by argument, however, that this process would not answer, because we have here not a stable bulk pushing against a horizontal abutment, but an unstable body which when pushed against will *capsize before it will slide*. That is to say, the wind pressure on a gasholder is an overturning force. The great unstable bell must be stayed in two horizontal planes. It tends to turn over in the direction of the wind, in order that its elevated center of gravity may assume a lower position of stable repose (fig. 2); and so

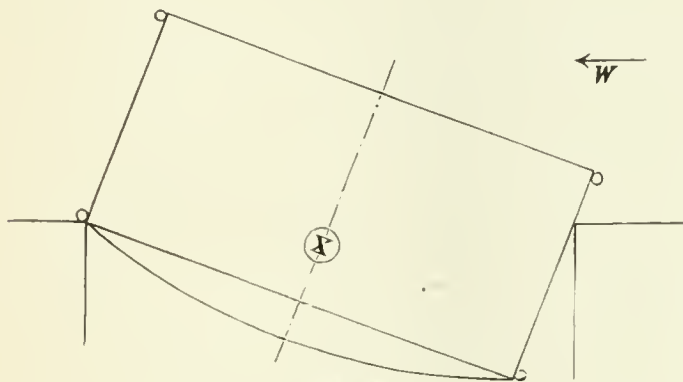

Fig. 2.

far from the bottom rollers taking the same strain and in the same direction as the top rollers, it is the *counter leverage* of the bottom rollers upon the opposite side of the tank—i.e., the side from which the wind is blowing—that maintains the stability of the holder (fig. 3).

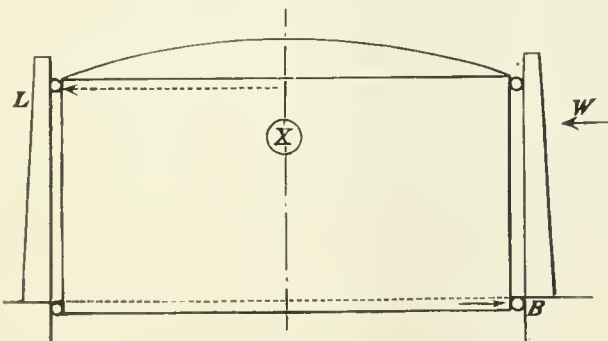

Fig. 3.

This is the explanation of the well-known fact—well known at least to practical gasholder builders—that the steadiness of a holder depends far more upon the tightness of the bottom rollers than upon any other condition. It is the practice of good gasholder erectors to make the bottom rollers fit the tank guides as tightly as they can be dropped into place. When this is done the proper adjustment of the upper rollers will enable

a holder to work without a tremor, however gusty the weather. Where the bottom rollers are loose, the absence of the necessary leverage permits the holder to roll about alarmingly, and no amount of nicety of adjustment of the top rollers will cure the mischief. When the bottom rollers bear tightly all round, the overturning leverage of the top-heavy holder is constantly opposed by the leverage between the *leeward* top roller and the *windward* bottom roller; and as the distance from the latter to the center of gravity is very much greater than the distance from the same center to the top roller, its controlling effect is correspondingly greater.

This demonstration of the part played by leverage, as distinguished from horizontal equable thrust, in the conditions of a holder's stability concludes the part of this paper which deals with established principles. We have now to inquire whether full acceptance of the hypothesis which has been thus briefly and imperfectly—but it is hoped intelligibly—sketched out entails any change in the ordinary method of gasholder guiding. The position of the writer is that it does involve an alteration of practice in correspondence with the altered conception of principle; and, further, that this change is in the direction of economy of material and shortening of time required for gasholder construction.

If the stability of a gasholder depends upon leverage as between the opposite top and bottom rollers, so that the tendency of the holder under outside pressure on one side to turn over without changing the horizontal position of its center of gravity is only balanced by this leverage, we have next to determine whether an equivalent leverage cannot be obtained in a better way than by calling in the intervention of a lofty framework—whether, in effect, the point of effort of the leverage XL , which is required to oppose XB in fig. 3, must necessarily be at the full height of the holder above the ground. From this point we must abandon all hope of obtaining light from experience gathered in gasholder construction, and must rely wholly upon inductive reasoning, based upon the example of other structures. We know that if a pole, for example, is required to be set upright on the ground (figs. 4 and 5), we can

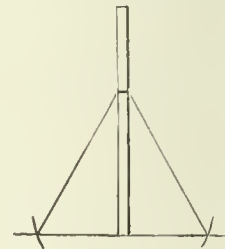

Fig. 4.



Fig. 5.

put it into a socket deep enough to supply the leverage necessary to its stability; or we can guy it from the top. To put it into a socket, however, implies a sufficient substance and strength in the pole to withstand the effect of the leverage of the free end, which tends under side stress to snap it off at the top of the socket. If we are doubtful as to the material of the pole being strong enough to endure this treatment, it must be guyed. Consider, now, a gasholder under the analogous position of being *stepped into a socket*, instead of guyed as the practice now is—have we any warrant for supposing that such a system of staying from the base instead of from the top would be safe? The answer to this query depends upon the sufficiency of the strength of the holder at the horizontal line of the supposed socket to withstand the overturning moment, which at this point becomes a force tending to tear apart the windward side and to crush the sheets on the leeward side of the holder (fig. 6).

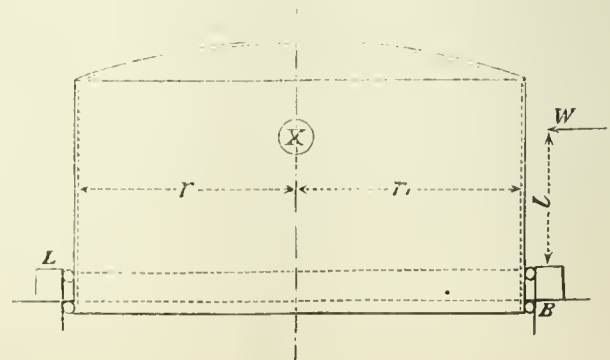

Fig. 6.

Returning to the already cited example of a telescopic holder 100 ft. diameter and 50 ft. high, which is supposed to be subjected to a maximum wind pressure of 20 lbs. to the square foot—amounting to a total pressure of 50,000 lbs. Let us now regard this as a pressure tending to break off the holder, held fast at the base in a kind of socket (L, B , fig. 6), just

like a stumpy pole similarly fixed. Let it be assumed also that the socket is 6 feet deep. Practically, the socket would consist of a circle of short piers carrying a continuation of the tank guides; and the requisite two points of bearing for the holder would be supplied by the ordinary bottom rollers secured to the bottom curb and a second tier 6 feet above them (fig. 6). There is no particular reason for the selection of 6 feet as the depth of the socket; this is merely a chosen depth for explaining the principle. We have here, then, a wind pressure of 50,000 lbs. to reckon with; and with reference to chimneys similarly strained, Rankine ["Applied Mechanics," 3d ed., p. 240] lays it down that the whole resultant of the pressure may, without appreciable error, be assumed to act in a horizontal line through the center of gravity of the vertical diametral section. In most holders the center of gravity is about one-fourth of the height from the top curve (see *X* in the diagrams). Hence, with the holder full, we should have to provide for the leverage of a force of 50,000 lbs. applied at a height of 12.5 feet from the top, and acting at a horizontal line of resistance 6 feet from the bottom. We have here, therefore, in this holder a vertical beam, of hollow cylindrical section, fixed at one end, and loaded at the other. The formula for computing the strength of a beam of this description is—

$$lW = \frac{SI}{x};$$

in which *l* is the length of the beam, in inches, between the center of pressure and the socket; *W* is the weight or pressure, in pounds, which will just break it; *S* is the coefficient of resistance to cross breaking, or modulus of rupture; *I* is the *moment of inertia* of the section of the

This is the breaking strain. Taking a factor of safety of one-fifth, we have a working strain of $\frac{18,842,660}{5} = 3,768,530$ lbs., which might be applied at the center of gravity of the holder under consideration. As a matter of fact, however, we have already seen that the holder cannot reasonably be expected to be exposed to more than 50,000 lbs. wind pressure; so that it may be regarded, upon this showing, as perfectly safe under the contemplated conditions—that is, without lofty guide framing, and merely stepped as it were into a socket 6 feet deep. The excess of strength may indicate some inapplicability of the formula; but it is the only one even remotely suggested for the solution of the question, and it is inserted here, without warranty, for what it is worth.

Now comes the question of the rigidity of the socket itself, which does not present any difficulty. Taking the extreme view that the holder is a lever of the third order, with a weight of 50,000 lbs. at *W*, supported by a power at *L* against an immovable fulcrum at *B*, the power *L* is found by the formula $L \times 72 \text{ in.} = 50,000 \times 450$; whence the resistance at *L* must be 312,500 lbs.

With the combination of tangential and radial rollers supposed to be employed in this case, two-thirds of the twelve dwarf piers which take the upper tier of guide rollers come into play at the same time. Hence we have $\frac{312,500}{8} = 39,062.50$ lbs. as the stress that may come upon any one of these points of resistance. These piers may be built of concrete or of bricks in cement, or may be made of iron, as preferred. The holder being one foot in the tank, the pressure will be at a height of 5

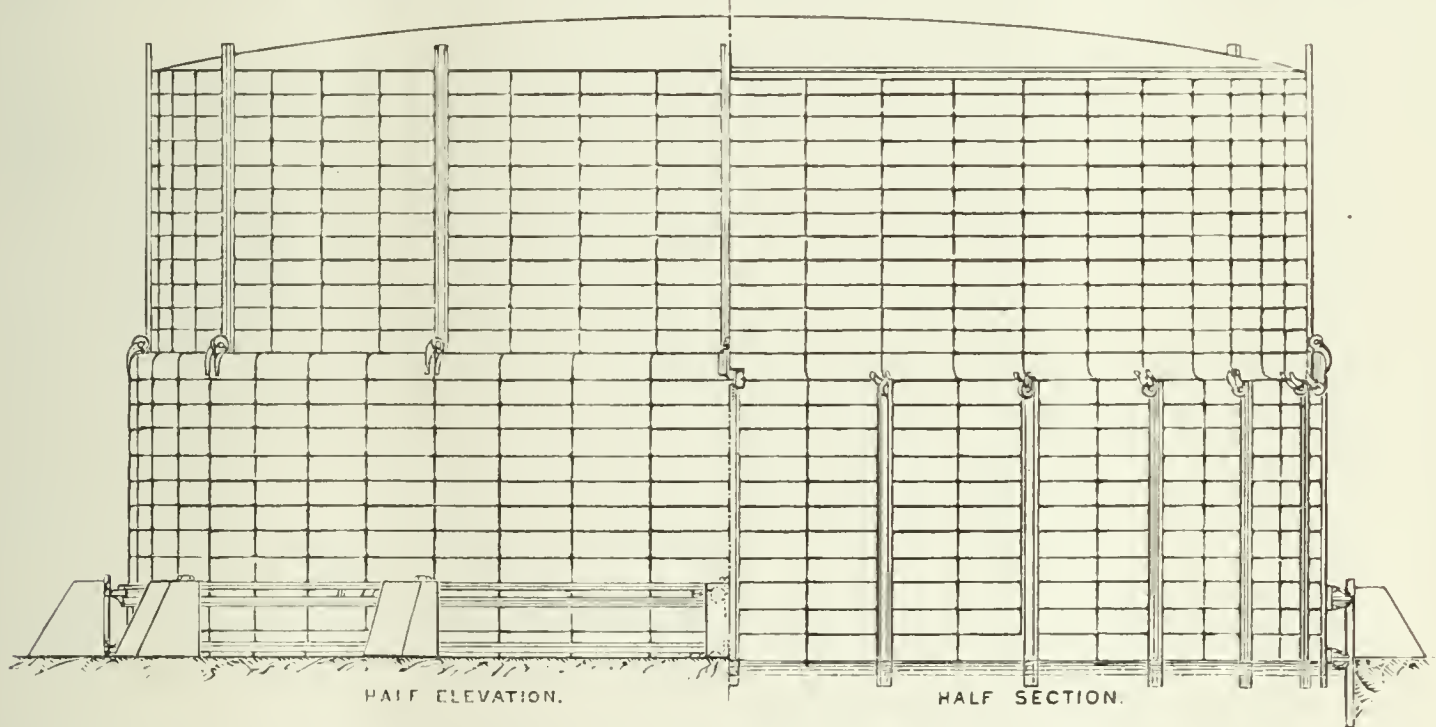

beam about its neutral axis; and *x* is the distance, in inches, of the neutral axis from the extreme fiber of the cross section.

In this case

$$l = 378$$

$$S = 42,000$$

$$\frac{I}{x} = \frac{\pi(r^4 - r_1^4)}{4r}$$

r and *r*₁ being the radii of the outside and inside of the cross section in inches.

The formula is very simple, but involves a good deal of work. The more correct way of applying it in the present case would be to use it for the determination of the thickness of the side plates and stiffeners of the holder. It will be simpler, however, to assume the value of *r* - *r*₁, or the thickness of the side sheeting, from considerations of common practice, and with this to work out the strength. Thus, in a 100-foot holder, the side sheeting will be (say) No. 14 S. W. G., or 0.080 inch thick; and the substance of the usual vertical stays, if equally spread over the sides, would increase their thickness by another $\frac{1}{16}$ inch. Thus we get an average gross thickness of about 0.15 inch; and the inner radius of the holder is, therefore, 599.85 inches, while its outer radius is 600 inches. The determination of the length of the beam, *l*, is arrived at by taking the distance from the center of gravity, *X*, which is 12 ft. 6 in. from the top curb of the holder to the top of the socket, which is 6 ft. higher than the bottom curb. It is, therefore, 31 ft. 6 in., or 378 inches. We can now write the formula as follows:

$$378 W = \frac{60 \times 3.1416 (600^4 - 599.85^4)}{400 \times 600}$$

$$W = 18,842,660.$$

feet above the bases of the piers. The tank guides, rectangular wrought iron boxes filled with concrete, 6 in. deep by 6 in. wide, are carried up the inner faces of these piers, and are the first to take the strain, of which they can be trusted with 4,190 lbs. This leaves 39,062.50 - 4,190 = 34,872.50 lbs. to be taken by the piers. Cement or brick piers 6 ft. deep at the base and 2 ft. 3 in. wide would be ample for this purpose.

One more observation, and the writer's task is done. It may be asked if the holder is strong enough to transmit all these strains to the point of support without taking some of the pressure off by means of external framing. To this it may be replied that if the holder is strong enough to withstand the strain at the top of the socket, where it is most severe—and this has been shown to be the case—it must necessarily be able to carry them at other points where they are less. So long as the holder preserves its true figure it will transmit exterior strains to the ground as perfectly as would a surrounding framework, and it must always preserve its figure while the pressure of gas from within is in excess of that of the wind outside, even without the help of the vertical stays and the curbs. A wind pressure of 20 pounds per square foot is only equal to a gas pressure of 38-10ths; so that most holders have an ample margin of internal force.

The writer is not desirous of claiming any originality for the proposal to dispense with lofty framing for gasholders. Recent correspondence in the *Journal of Gas Lighting* has shown that practical trials, and successful ones, too, were made in this direction by Mr. Joshua Horton, gasholder builder, of Smethwick, who took out a patent for his method of construction in 1851. This design dispensed with the top rollers, but placed short standards on the top of the grip of the outer lift, with fixed

rollers bearing against the sides of the top lift to insure the cupping of the holder. This is, indeed, the critical period of the working of the holder; and in the accompanying illustration a modification of the same device has been adopted for additional security. In a paper read before the North of England Gas Managers' Association, in 1882, Mr. V. Wyatt also sketched a telescopic holder without lofty guide framing. Mr. Wyatt's holder, however, although its stability would depend upon the principles herein set forth, differs from the writer's ideal in several particulars. Mr. George Livesey also said, at the meeting of the Institute in 1882, that "with the combined system of rollers it may be found that gasholders will work well and safely with a guide framing considerably short of the height to which the holder rises." A desirable sense of actuality is imparted to the present discussion of this subject by the fact that Mr. Livesey is about to add a third lift to a holder at Rotherhithe without correspondingly raising the guide framing.

While refraining from claiming originality, however, for the idea of seriously modifying the guiding arrangements of gasholders so as to dispense with lofty framing, the writer believes that this is the first attempt to place the subject upon a rational basis which renders the problem susceptible of theoretical and practical investigation and proof by any engineer who may be sufficiently interested in the matter.

Discussion.

The President said, to prevent any misunderstanding he ought to state that the drawing did not represent any holder now being constructed.

Mr. Corbet Woodall (London) said, although they might not be disposed to adopt Mr. Webber's theories with reference to gasholder construction, they would all thank him for having given an admirable paper, and a healthy shock to anything that might be called stereotyped ideas on gasholder guiding and construction generally. It was quite possible to acquiesce with very much of Mr. Webber's reasoning, while differing altogether from the conclusions at which he arrived. If a floating gasholder could be properly compared to a stumpy pole fixed in the ground, or to a chimney set upon its base on the solid, then he should be much more disposed to agree with Mr. Webber; but he thought it would be found that these comparisons failed in several respects. The primary object of the guide framing of a gasholder was clearly to allow of the holder rising and falling freely, and at the same time to prevent it taking such a cant as would be likely either to cause it to wreck itself by tumbling over, or to do so to such an extent as to jamb between the guides, or to unseat the cup. Two things, therefore, had to be provided for—one that the framing should have strength enough to resist the utmost effect of the wind pressure, or the unequal leewarding through snow; and, secondly, to keep the holder upright and counteract any tendency to tilt. As to the wind pressure, he was satisfied they would be perfectly safe in accepting Mr. Webber's estimate of 20 pounds per square foot as the maximum pressure on the side of the holder, and in taking half the vertical cross section of the holder as the area exposed to that pressure, in which case 50,000 pounds, or 22½ tons, would be the total amount of pressure ever brought on the holder. So far he agreed; but he differed entirely as to the effect of the pressure and its distribution. The center of pressure would in the case of a holder be at the center of its height, which was "the center of gravity of its diametral section," and not at the center of gravity of the weight of the holder. This being so, then in a holder guided according to present custom, the pressure would be evenly divided between the top and bottom rollers on the leeward side; each taking (in the case suggested in the paper) 11¼ tons. The pressure on each tier would be the same as if the entire wind pressure were concentrated in the center, and applied by simple leverage to the two rows of guide rollers. He could see no reason why because the center of gravity of a holder was high, the center of pressure of the wind acting uniformly over the whole area should be high also. Turning to the question of weight, the conditions were different. It must be admitted that a floating vessel, such as a gasholder, having its center of gravity very high and far above the center of buoyancy, could have no stability of its own, such as a chimney, and as it would itself have if lifted off the water and set upon the ground. If it rolled, it had no righting power as a ship possessed, because, unlike the case of a ship, there was no movement of the center of buoyancy to balance the alteration of gravity. Taking Mr. Webber's statement that the center of gravity was at a quarter of the height from the top, or 12½ feet down, then only while the holder was floating at a less height than this would it have any stability; when it rose higher than 12½ feet it would turn over before the first mild breeze, if not kept firmly in place by the guide framing. If the holder was allowed to cant to one side, then (and to the extent of the cant) the weight of the holder would aid the overturning tendency; and in this case, differing entirely from

the wind effect, the pressure on the rollers would be distributed, as Mr. Webber stated, between the leeward at top and windward at bottom. Assuming the weight of the holder to be 100 tons, then there would be an overturning tendency or moment of 100 tons multiplied by the distance through which the center of gravity was moved. He maintained that beyond doubt the effect of a strong wind upon a holder in such a condition, if guided in the ordinary manner, would be to push it upright against the leeward guides. Suppose it was lying over against the top roller, and the wind were blowing with the maximum force of 20 lbs. per square foot, then the pressure would act upon the top roller as a fulcrum, with a moment of 22½ tons multiplied by 25 feet, the leverage from the center of pressure, and would exert a force of 562 foot-tons in the direction named—viz., to set the holder upright. If, however, the rollers were arranged as Mr. Webber proposed, then the stresses due to wind were clearly added to those due to weight, instead of tending to neutralize them. Much importance did not attach to the matter of weight in an ordinary holder, because it should never come into play. With Mr. Webber's plan it was very important, because the holder would be much more likely to tilt. It was hardly necessary to point out the advantage of having the points of support at a considerable distance apart vertically, in order to counteract this tendency to tilt. Allowing that there was some horizontal play between the rollers and the guides, then the vertical tilt would be greater than this horizontal play in the proportion of the diameter to the vertical distance between the rollers.

Taking Mr. Webber's 6 feet for 100 feet diameter, it would be $\frac{100}{6} = 16\frac{2}{3}$.

Consequently, ½ inch of play would mean a tilt of 8 inches. But the proposal assumed a degree of accuracy in fitting the guides and rollers of a holder, and a degree of strength in the sides, which was practically impossible of attainment. Gasholders must, it seemed to him, become different, more costly, and elaborate structures altogether, if the scheme were to be adopted with a chance of success. The proposal to use the strength of the holder itself, instead of relying on an external framing was one with which in itself the meeting would be in sympathy; but, upon consideration, he greatly questioned the wisdom of conveying the heavy strains to which the holder was subjected through itself to the base, having regard to its primary object, which was to contain gas, and not to lose it through leaks. The tendency to tear the sheets across on the windward side, which was the only method of failure dealt with by Mr. Webber, was, in his (Mr. Woodall's) opinion, not so formidable a risk as would be the risk of local failures from indentation about the roller carriages under strain. He thought, for the reasons he had given, that while the risk from adopting the author's proposal would be inconsiderable, the promised economy was very doubtful. The cost of a holder so built would be very heavy, probably as great as one provided with external framing. In order to make the bottom rings of rollers so rigid as to keep their form and resist the tendency to crush in, to however slight an extent (for almost absolute rigidity was essential even to the existence of such a holder), so much metal must be used in internal curbs and otherwise as would go far to dissipate the outside saving. Extra vertical guides would have to be provided, and in workmanship as well as material the expenditure must be greater. Altogether, it seemed to him that, interesting and valuable as was the suggestion made by the writer of the paper, the probability of his plan as now set forth being adopted was not a bright one.

Mr. C. Hunt (Birmingham) said that, unlike Mr. Woodall, he saw no reason to differ from the author in regarding the gasholder as a post or pole fixed in a socket, nor in accepting his proposition respecting the effect of the overturning force on the center of gravity. Of course, they knew wind pressure was exerted, presumably, equally over the area; but the effect must follow its capacity of resistance proportioned to its weight and depth. While agreeing with Mr. Webber so far, he could not admit the formula which he had put forward as applicable to this case; and although he had not been able to follow out the logarithms which accompanied the diagram, he had been favored with a copy of the paper, and had taken the precaution to work out the calculation. His figures had been carefully checked, with the result that he made the measure of resistance of such a holder as 18,000,000 odd pounds, instead of 1,800,000 odd, according to Mr. Webber. The meeting would, therefore, no doubt agree that one of the two must be wrong. [As intimated in the paper, this correction has now been made.] But even apart from that, the resistance of the holder by that formula was shown to be so excessive that he did not think it could possibly touch the case at all. There must be a limit to the application of such formulæ. It was no doubt adapted to moderate-sized girders standing on end; but he doubted extremely its application to gasholder construction. All the same, while not prepared to admit the feasibility of Mr. Webber's plan, he would

rather reserve his judgment upon it until he had seen that portion of it which was advocated by Mr. Livesey carried out. He was not prepared to deny the practicability or utility of the plan under discussion; but at the same time it was one the merits of which could not be decided by theoretical reasoning.

Mr. G. Livesey (London) said he certainly was not going into these figures on such an occasion. He might say they were about to try trebling a double-lift gasholder without continuing the framing up to the third lift; and after a very full consideration of the subject (his friend, Mr. Morton, had given a good deal of thought to it), they came to the conclusion that there was no objection whatever, and no difficulty and no danger in so doing, by adopting the combined system of rollers—the tangential and radial—for the two lower lifts. The upper lift would have its jib and radial roller to guide it until the second lift was cupped, then it would go clear of the framing, and the jibs stand free, feeling, as it were, in the air for the guides which they could not find. He thought the large holder at East Greenwich might be done in the same way; particularly when they found it was necessary to adopt the system of four lifts for that holder. Originally it was to have three lifts, each 60 feet deep; but the nature of the ground compelled them to alter that, and to adopt four 45-foot lifts. He then felt that there would be considerable saving if they could dispense with the guide framing for the upper lift. A very eminent engineer, perhaps the most eminent in the profession with regard to stresses and wind pressure, was consulted; and he said there would be such a variation in the stresses and strains brought on the upper lift, that to meet them would be more troublesome than the old system, that it was thought advisable to give up such an experiment on so large a structure. He was satisfied, however, it could have been done for all that, and they were now doing the same thing at Rotherhithe. Mr. Ashmore had it in hand, and he did not think he had any fear as to the result. Mr. Webber had stated that something of the kind was tried successfully at Bankside; but in that case he thought the word “successfully” might be left out, for he was informed by Mr. Somerville, who inquired of men on the premises, that the gasholder was never inflated. It was a three-lift holder, with framing up to the height of the second lift. The inner lift was to be guided until it cupped by an arrangement like that on Mr. Webber’s plan. But it would not go upright; the inner lift would tilt. It never was filled, and after standing a year or two empty, Mr. Innes, the then Engineer of the Phoenix Gas Company, decided to pull it down—that was the end of it. He could not agree with Mr. Webber that a gasholder would be safe guided as he had shown. He was not able here to enter into arguments to prove he was wrong; but he had the feeling that there was some uncertain element in the question which would bring a gasholder to grief if guided in that way. Possibly the use of the system of combined rollers adopted at the Old Kent Road would help materially. One great difficulty was that he did not see how the inner lift was to be guided until it was cupped. He felt quite certain that if the inner lift was guided with just a series of rollers stuck a few feet above the cup of the second lift bearing against the outside of the inner lift, it would tilt continuously and regularly. Then it came to this, that although he could not prove Mr. Webber was wrong, he asked himself the question, What was the good of it? What was the good of trying to dispense with framing altogether? Mr. Woodall had touched on the same point; but even if Mr. Webber were right, it would probably cost as much or more (besides considerably increasing the weight of the holder) than carrying the framing up to the height of one lift. Now, he believed a gasholder could be successfully guided by having the framing up to this height. Thus, with a holder of three lifts, 30 feet each, the guide framing would be carried up to the height of about 35 feet. This would guide the inner lift until it lifted the second, when the top rollers would go above the framing. The second lift would then be guided until it lifted the third, and its rollers, in turn, would go above the framing; and then the stability of the holder would be dependent on the top and bottom rollers of the third lift, which, he really believed, would be sufficient to safely support a gasholder properly constructed. If this were so, he should contend that it would certainly be cheaper and more simple than the plan recommended by Mr. Webber; but, after all, it was only a question of degree. Nothing had come up more strongly in the paper and discussion than the further proof that these gasholder questions were extremely difficult to understand. There was an element of uncertainty, and however bold an engineer might be, they must be governed by prudence. It would certainly not be wise for any engineer to make an experiment of this kind unless perfectly certain it would be safe. He was afraid that Mr. Webber had not convinced them that it would be perfectly safe; and, this being so, he should say, “Do not try it,” but they might dispense with the top part of the guide framing in the first instance. This they were trying, and he had very little doubt

of success. They might then take another step, and dispense with the second tier of framing; but there he should stop.

Mr. Moore (Macclesfield) said he was not going to discuss the paper, as it was impossible for him to examine reasoning based on figures which were so intricate offhand and without due time for thought. He rather rose to suggest that arrangements should be made for members of the Institute who took an interest in any particular paper obtaining copies in time for them to condense their remarks in an intelligible and concise way, so that the meeting would have the patience to listen to them. With respect to wind pressure he wished to say that some four years ago when designing a gasholder, and when this matter was very much in his mind, a storm occurred a little to the south-east of Manchester, and blew a railway truck off the line into a field. He put himself in communication with the railway people, and found afterwards, from the weight of the material and other particulars he had obtained, that, using the ordinary formula, it would take 38 lbs. on a square foot to exert sufficient force to blow the truck into the field. To the windward of the truck, only 400 yards off, there were several trees uprooted; but to the leeward of it, and in the direct line of the storm at the same distance, there was a hay shed, a very fragile structure, quite uninjured. This led him to the belief that these wind pressures were very largely determined by the focussing of the force, and sometimes on a very small area; and something of this description must have occurred in the case he alluded to.

Mr. T. May (Richmond) said it seemed to him that the strength of the holder would be very much increased if some part of the guide rollers to the bottom lift were kept in the channel guides by the short piers. There appeared to be no stay for the upper lift when it was rising, because the lower lift was free to swing about between the guides.

Mr. W. T. Batten (Singapore) asked what would be the excess of the extra back pressure which a holder constructed in the way suggested would give; because, for small works, this was a very important consideration. If there were a heavy back pressure the manager would find his purifiers blowing, and many other disadvantages from which perhaps many large works would not suffer.

Mr. Webber desired to thank those gentlemen who had criticised his paper. One word, however, would dispose of a good deal of the criticism which had been offered. He had simply put forward a suggestion, and mentioned in almost the first words of the paper that it was nothing but a suggestion which had to be proved. He did not go so far as Mr. Livesey by a long way, because that gentleman actually said there should be no hesitation in doing this, that or the other. He (Mr. Webber) simply said that this was a matter that could be proved by experimental research; and if anyone would undertake the necessary experiments he would find that the results would point in the direction to which his paper referred. With regard to the back pressure, this was a matter which could be easily computed by the weight of metal put in. Mr. May suggested the difficulty of another roller. That was a matter of compromise. Mr. Moore cited the example of a railway truck having been blown over, which only went to prove what he said in the paper with regard to the pressure of wind—that these intense pressures were always very local. Even in the case of American experience, where they had tornadoes, which very frequently blew down houses, it was quite possible that another house standing next door would be untouched. There had never been any record of a pressure of that intensity being distributed over such a large area as the whole surface of a gasholder. The difference between Mr. Livesey and himself was only one of degree; in fact Mr. Livesey was more convinced really than he was himself, because Mr. Livesey said he should have no hesitation in putting up a three-lift holder with a framing up to the bottom lift only. He (Mr. Webber) should be perfectly content with this, too, for a step; and he felt that, if Mr. Livesey could do this, he would find the other matter—shortening the leverage from the top of the bottom lift down to the height of 6 or 7 feet above the tank—would be merely a further step. He fully admitted that in this matter they must proceed by steps. He could not agree with either Mr. Livesey or Mr. Woodall in the idea that there was nothing to be gained by his suggestion, as it must be evident to anybody that any extra weight of material that was needed in a holder of this description was very much less indeed than that required for an ordinary framework; and, what was more, it was much more easily applied, because, if anything, it was only the strengthening of members which already belonged to the gasholder. They already had vertical stays and curbs, and only needed to modify them a little, and perhaps make them rather stronger. The holder looked very heavy and formidable on the drawing. But that was not made to scale; it was merely to show how the thing could be put together. Again, the element of time in the erection of a gasholder was a very serious one. Gasholder constructors did not always finish by the time they promised; and if they could relieve

them from the necessity of putting up external framing after the holder was in, and going through all the arrangements of plumbing it, there would be a very great saving of time and money. Mr. Hunt differed from Mr. Woodall and practically answered him, because he accepted fully the theory which Mr. Woodall denied—that a holder could be regarded as a stumpy post set in a socket—and he would leave these two gentlemen to settle their difference between them. He (Mr. Webber) fully admitted the difficulty that the formula for a beam fixed at one end and loaded at the other had never been applied to the scale to which he had expanded it now. It had never been proved by anybody that the formula could not be so extended; but as they all knew that the strength of the beam depended upon its depth, and as the beam was so extremely deep in proportion to its length, he thought he was rather on the safe side. However, with regard to all these matters, what he should strongly recommend to settle all these doubts and difficulties was experiment. It was impossible to refute these suggestions, except by reference to facts which were not at present in the possession of any member. He had looked into the matter thoroughly, and he thought that if any two or three gentlemen wanted to construct a gasholder, and they would only have a scale model constructed, observing, as nearly as possible the actual proportion between the scale and the original—just the same as big shipbuilders did with regard to the building of ships in order to find out the actual velocity at which a ship would go—if they would do this, follow it out, and see how it would stand, such an experiment would teach them more than anything he had been able to say. His only object was to get at the truth of a very intricate matter.

The President said however much they might differ in their views with regard to the paper, it was one full of suggestion on a subject which was certainly very intricate. A gasholder was a thoroughly unstable structure, having in itself no stability whatever; and the difficulty of estimating exactly the different forces which acted upon it involved problems which were exceedingly complicated, and at present almost impossible to solve for want of experimental data. He therefore thought that Mr. Webber's suggestion that they should make experiments so as to ascertain really what forces were required to maintain a gasholder in an upright position was a very wise one. It would be exceedingly interesting to determine what force it was which restored a holder to the perpendicular position when it was rocking with the wind. Certainly not gravity, which would tend to throw it still further out of the perpendicular; yet in some way or other its equilibrium was restored. It was exceedingly important to ascertain what the restoring force was. Most probably, he thought, the explanation was this, that the holder did not rock as they supposed by going first over at the top, but the bottom ring being more elastic than the stiff top ring, it yielded to the pressure of the wind, causing the holder to fall over towards the wind. The elasticity of the bottom ring would thus be the righting force. This was an important point which might be determined by experiment. Mr. Webber based a great deal of what he said upon the assumption that the wind pressure had no tendency to push a gasholder along a horizontal plane. But in this he could not agree with him. A gasholder was, to a certain extent, a floating body like a floating ship—an unstable ship, certainly; and the wind tendency must be to press such a body forward laterally, and just because it did press it forward laterally a holder did not require anything like the amount of framing which would otherwise be necessary. The holder, when fairly resting upon both top and bottom guides, became then a complete structure in one with the guides, and the weight of the holder then tended to prevent upsetting.

The Pyro-Magnetic Dynamo.

During the recent sessions of the American Association for the Advancement of Science many interesting papers were read, but probably the one that will have the greatest attraction for gas engineers was contributed by Mr. Thos. A. Edison (the paper was read by Prof. Geo. F. Barker), who wrote on "The Pyro-Magnetic Dynamo—a Machine for Producing Electricity Directly from Fuel." We herewith reproduce the essential points of Mr. Edison's communication:

The production of electricity directly from coal is a problem which has occupied the closest attention of the ablest inventors for many years. Could the enormous energy latent in coal be made to appear as electric energy by means of a simple transferring apparatus which accomplishes its result with reasonable economy, it will be conceded probably that the mechanical method of the entire world would be revolutionized thereby, and that another of those grand steps of progress would be taken of which the nineteenth century justly boasts.

The simple production of a potential difference by means of heat is as

old as Leebeck and Melloni. The science of thermo-electricity, thus originated, has been developed by Becquerel, by Peltier, by Thomson, and by Tait, and the thermo batteries of Clamond and Noe have found many important practical uses. The results already attained in these generators have stimulated research marvelously, and many investigators have believed that in this direction lay the philosopher's stone. Our fellow member, Moses G. Farmer, worked long and assiduously in this field, producing, it is believed, the most satisfactory results as regards economy which have ever been obtained. But even these results were not very encouraging. He never succeeded in converting one per cent. of the energy of the coal into electric energy.

Quite recently Lord Rayleigh has discussed with his well-known ability the law of efficiency of the thermo battery from the standpoint of the second law of thermo dynamics, and he concludes that for a copper-iron couple, working between the extreme limits of temperature possible for these metals, a conversion of not more than one three-hundredth part of the coal energy can be hoped for. As a heat engine, therefore, the thermo-cell appears to follow precisely the law of Carnot, and hence can have at the most no higher efficiency than the reversible engine of this eminent philosopher. If, therefore, the result hoped for is to be attained at all it must be looked for in some other direction obviously.

It has long been known that the magnetism of the magnetic metals, and especially of iron, cobalt and nickel, is markedly affected by heat. According to Becquerel, nickel loses its power of being magnetized at 400°, iron at a cherry-red heat, and cobalt at a white heat. Since, when ever a magnetic field varies in strength in the vicinity of a conductor a current is generated in that conductor, it occurred to me that by placing an iron core in a magnetic circuit, and by varying the magnetizability of that core by varying the temperature, it would be possible to generate a current in a coil of wire surrounding this coil. This idea constituted the essential feature of the new generator, which, therefore, I have called a pyro-magnetic generator of electricity.

The principle of utilizing the variation of magnetizability by heat as the basis of electric machines, though clearly applicable to generators, was first applied to the construction of a simple form of heat engine, which I have called a pyro-magnetic motor. A description of this motor will help us to understand the generator subsequently constructed. Suppose a permanent magnet having a bundle of small tubes made of thin iron placed between its poles, and capable of rotation about an axis perpendicular to the plane of the magnet, after the fashion of an armature. Suppose, further, that by suitable means, such as a blast or a draught, hot air can be made to pass through these tubes so as to raise them to redness, suppose that by a flat screen symmetrically placed across the face of this bundle of tubes and covering one-half of them, access of the heated air to the tubes beneath it is prevented. Then it follows that if this screen be so adjusted that its ends are equidistant from the two legs of the magnet, the bundle of tubes will not rotate about the axis, since the cooler and magnetic portions of the tube-bundle—that is, those beneath the screen—will be equidistant from the poles, and will be equally attracted on the two sides. But if the screen be turned about the axes of rotation so that one of its ends is nearer one of the poles, and the other nearer the other, then rotation of the bundle will ensue, since the portion under the screen, which is cooler, and therefore magnetizable, is continually more strongly attracted than the other and heated portion. This device acts, therefore, as a pyro-magnetic motor, the heat now passing through the tubes in such a way as to produce a dissymmetry in the lines of force of the iron field, the rotation being due to the effort to make these symmetrical. The guard-plate in this case has an action analagous to that of the commutator in an ordinary armature.

The first experimental motor constructed on this principle was heated by means of two small Bunsen burners, arranged with an air blast, and it developed about 700 foot pounds a minute. A second and larger motor is now about finished, which will weigh nearly 1,500 pounds, and is expected to develop about three-horse power. In both these machines electro magnets are used in place of permanent magnets, the current to energize them being derived from an external source. In the latter machine the air for the combustion is first forced through the tubes to aid in cooling them, and then goes into the furnace at a high temperature.

The earliest experiments in the direction of the pyro-magnetic production of electricity were made with a very simple apparatus. The success was such that the construction of a machine of sufficient size to demonstrate the feasibility of producing continuous currents on a large scale in this way was at once begun. This machine is placed upon the top of any suitable furnace, fed by a blast, so that the products of combustion are forced up through the tubes which are not covered by the guard-plate and raise them to a high temperature.

The potential difference developed by this dynamo will obviously de-

pend (1) upon the number of turns of wire upon the armature coils; (2) upon the temperature difference in working; (3) upon the rate of temperature variation; (4) upon the proximity of the maximum point of effect. Experiments have shown that the guard-plate can probably be made to revolve 120 times a minute. Since the potential difference is proportional to the number of lines of force cut per second, it is evident that, by doubling the speed or rotation, twice as many lines of force would flow across the generating coils per second, and the output of energy would be quadrupled. Exactly what thickness of metal is the more suitable for the purpose; what the relative volume occupied by metal and by air space in the interstitial armature should be; what is the best diameter for this armature, or even the best metal; what the best limits of temperature, and what the best speed of rotation to produce the maximum potential difference; all these are questions which must be decided by experiments made upon the generator itself.

The results thus far obtained lead to the conclusion that the economy of production of electric energy from fuel by the pyro-magnetic dynamo will be at least equal to, and probably greater than that of, any of the methods in present use. But the actual output of the dynamo will be less than that of an ordinary dynamo of the same weight. To furnish 30 sixteen-candle lights in a dwelling house would probably require a pyro-magnetic generator weighing two or three tons. Since, however, the new dynamo will not interfere with using the excess of energy of the coal for warming the house itself, and since there is no attendance required to keep it running, there would seem to be already a large field of usefulness for it. Moreover, by using the regenerative principle in connection with it, great improvement may be made in its capacity, and its practical utility may very probably equal the interesting scientific principles which it embodies.

SPECIAL ENGLISH CORRESPONDENCE.

COMMUNICATED BY NORTON H. HUMPHRYS.

SALISBURY, August 10, 1887.

Coke and Breeze as Boiler Fuels.—Mr. Lewis T. Wright Lectures on Coal Gas.—A Remarkable Accident.—Mr. Magnus Ohren and the Sulphur Compounds.—The Accounts of the Gas Light and Coke Company.

Some experiments on the use of coke, also of breeze and screenings, as fuels for steam boilers, have recently been carried out at the St. Pancras station of the Gas Light and Coke Company, London. They are interesting in a twofold sense; first as illustrating a useful application for coke, and, secondly, as showing the possibility of turning to account that which has hitherto been regarded as an almost valueless residual. Both fuels were taken from the usual produce of the works, and the coke was burnt in an ordinary furnace, while a special arrangement, known as Perret's patent grate, which has already acquired a footing as a capable appliance for using coal dust or other powdered fuel, was used for the screenings. The experiments were conducted under the joint direction of Mr. G. N. Horton, the engineer of the works, and Messrs. Bryan Donkin & Company, the manufacturers and agents for the sale of Perret's patent grate. Attention has already been drawn to the use of coke as a boiler fuel by Mr. Thomas Fletcher and others; but the application of what may be termed the refuse from the coke and breeze heaps is of a novel character. The coke was used under an ordinary Lancashire boiler, 26 feet long by 7 feet diameter, and so worked as to maintain a steam pressure of 44 pounds per square inch. The quantity used during the 8 hours' trial was 1,937 pounds, or 242 pounds per hour. The coke contained 5 per cent. of moisture, and left a residue of unconsumed ash and clinker amounting to 8½ per cent. The draught in the chimney was equivalent to 0.3 inches of water, the temperature of the products of combustion 556°, and an analysis of the gases showed that combustion was complete, the air supply being 50 per cent. in excess. This shows that the coke was used to the best advantage obtainable in an ordinary grate furnace. The quantity of water evaporated was 18,363 pounds, or 2,295 pounds per hour, and taking the value of the coke at \$3.60 per ton, the cost of a quantity sufficient to evaporate 1,000 gallons of water would be \$1.69.

This compares very favorably with the cost of coal, and in comparing it with other published experiments it is well to remember that sometimes the results are stated in pounds of water evaporated at 212°, or, at any rate, with a much less pressure of steam.

The results with breeze dust are perhaps the most interesting, because at many gas works this is given away to anyone who will fetch it, and in any case it is not worth carting to any considerable distance, therefore any plan for utilizing it on the spot is the more attractive. In this case

two Cornish boilers, each 24 feet long by 6 feet diameter, were used, the steam pressure being maintained at 44 pounds, as in the former case. The quantity of fuel used was 3,835 pounds in eight hours, or 479 pounds per hour. It contained 5 per cent. of moisture, and left a residue of unconsumed ash and clinker of 18 per cent. The layer of fuel in the furnace was only 7 inches thick, whereas with the coke it was 15 inches thick. The draught in the chimney was equivalent to 0.2 inches of water, and the temperature of escaping gases 485°. Combustion was not quite complete in this case, as, although the air supply was adjusted in the same proportion as when coke was used, the products of combustion were found to contain 2.21 per cent. of carbonic oxide. The presence of an excess of free oxygen, and also of carbonic oxide in flue gases is rather unusual. Probably, on account of the large percentage of ash, the distribution of the air supply was not equal in all parts of the furnace. The quantity of water evaporated was 25,005 pounds, or 3,126 pounds per hour, from which it would appear that the breeze firing could be introduced to any boiler, without any important reduction in evaporative effect. And it is remarkably cheap. The value per ton at St. Pancras is only 16½ cents, at which rate the cost of a quantity sufficient to evaporate 1,000 gallons of water would be only 11½ cents.

Perhaps the most important public event, so far as the gas industry is concerned, during the past month has been the delivery of four lectures by Mr. Lewis T. Wright, Engineer of the Nottingham Corporation gas department, at the City and Guilds of London Institute, South Kensington, before the students who are preparing for the Institute's examination in "Gas Manufacture." At most of our principal towns, such as London, Manchester, Nottingham, Birmingham, etc., there are now centers for cheap technical education, and the gas industry, of course, ranks amongst the subjects taught; so that any young man who is so fortunate as to reside in one of these cities, or has the means of living in them for a time, can get a technical training so far as the educational part is concerned. It is unfortunate that those who do not enjoy these facilities are shut out. For instance, a manager of a gas works in a small country town may have a son growing up whom he would wish to bring on to succeed him in his business; but unless he can afford to send the lad to one of these towns for at least six months or so these advantages are lost to him. Every now and then there is a sort of spasm on this educational question in the Gas Institute, and it appears to waken to a sense that something ought to be done with regard to the training of future gas engineers; while it does nothing, however, the Government and these Institutes are silently filling up the gap, and the question for the Gas Institute gradually becomes narrowed into the consideration of what assistance it can offer, if any, to those members who are desirous of participating in these advantages. And these lectures by Mr. Wright seem to be a move in the direction of spreading the facilities offered for technical instruction beyond the immediate neighborhood in which the Institute operates. Many young men who are unable to enter for a course of lessons could manage to attend lectures; and in addition to this there is the important consideration that the lecture hall admits of much fuller illustration, in the way of specimen, model and diagram, than the class-room. To students who have already laid in a foundation of knowledge gathered from books, from inspection of existing gas works plant, and, best of all, from practical experience, such lectures are more valuable than a course of lessons, and in order to give an idea of the nature of those delivered by Mr. Wright, it will be sufficient to remark that the first was devoted to a consideration of the various kinds of coal and other raw material used for the production of gas; the second to destructive distillation and the retort house work; the third to the removal of impurities from the crude gas, and the fourth to gas testing and analysis.

An accident which has occurred at a small private gas works supplying some spinning mills is worthy the attentive consideration of gas engineers. An old gasholder was to be dismantled and removed to make room for a new one. Accordingly a workman, having first removed the manhole cover, proceeded to rip the plates off the roof with a pickaxe. In doing this he produced sparks by the violence of his blows, and an explosion followed which tore up the whole structure. The sparks ignited the contents of the crown of the holder, into which sufficient air had leaked to form an explosive mixture. Four men were on the holder at the time; one of these has already died, whilst a second fell into the tank and was killed, and the others are severely injured. If the manhole cover had been removed some hours previously to commencing operations, say, on the day before, this disaster would not have happened; and it illustrated the importance of avoiding anything in the way of percussion in localities where an explosive mixture of gas and air may possibly exist.

Mr. Magnus Ohren, Secretary of the Crystal Palace District Gas Company, and a past president of the Gas Institute—who, by-the-way, cele-

brates his jubilee this year in common with Her Majesty, the Queen, since he has just completed his fiftieth year's experience in connection with the gas industry—in writing to a local authority in his district in reference to a compliment as to the low proportion of sulphur compounds in the gas supplied by his company, remarks; “I am to point out, as we have done on former occasions, that we at all times take every precaution, and adopt the best known means for maintaining the purity of our gas; but with our present knowledge of the so-called sulphur compounds, it is impossible to keep them at one uniform standard, and we find, as a rule, that we get the best results in warm weather.” As is common with most of the London Gas Companies, the Crystal Palace District Company is now, according to the returns of the official examiner, sending out gas containing not more than 10 grains of sulphur per 100 cubic feet, and often considerably less. This quantity represents about one part in 2,200, or something less than one-twentieth of one per cent.

The directors and all concerned in the management of the Gas Light and Coke Company are to be congratulated upon the remarkable improvement in the state of their affairs, which is evidenced by the statement of accounts for the six months, ended June 30th last. The profit earned during the period in question is £601,930, whereas during the corresponding period of 1886 it was £477,282. There is a magnificent increase in profits to the extent of more than £120,000, or some 25 per cent. on the gross amount, and yet, strange to say, this remarkable event is passed over without notice in the shareholders' report. The result is that whilst in the two previous periods, the first and second half of 1886, a large dip had to be made in the balance of undivided profit in order to pay the maximum dividends, the Company is now in a position to recoup at one stroke a considerable part of this deficiency, as the sum above named, after providing for full dividends, leaves a handsome balance of about £100,000. One naturally turns with curiosity to the statement of accounts in order to find the cause of this improvement, and it is at once evident that, while the receipts have been increased, the expenses for the most part have been reduced. About one-half of the increase in profits above noted is accountable by the increase in quantity of gas sold, and the increased receipts for tar and liquor, and the remainder is chiefly due to a reduction in the cost of coal, and in the “Repair and maintenance of works, mains and meters.” The latter items now amount to about £180,000, whereas during the corresponding period of last year they were something like £230,000, so there is a saving of £50,000; and I look with interest for the report of the shareholders' meeting, at which it is possible that some explanation will be offered as to the causes which have enabled this large economy to be effected, and also as to whether it may be expected to be of a permanent character. The Company has been put to a heavy expense for legal charges; but with their enormous scale of working, this is a mere trifle to them. The directors, however, very pertinently remark: “The fact of the Company being thus harassed by legal proceedings, carried on to a great extent at its own expense, may or may not obtain the sympathy of the public; but it should be clearly understood that the effect of such wasteful and unnecessary expenditure by local authorities must be to render more remote a reduction in the price of gas to the consumers.” This fact cannot be too clearly laid before the consumers; for where an undertaking is worked under limitation as to rate of dividend, it is evident that any extraordinary expenses must be defrayed out of the balance of profits remaining after paying for materials, labor and establishment charges; or if the expenses are defrayed out of capital, they then become a permanent debt upon which interest must be paid.

Dr. Flock's Experiments on Coal Oil Lamps.

In the earlier part of the current year Dr. Flock, of Berlin, was engaged by the Normal Aichungs Commission, of Germany, to carry on a complete series of investigations in regard to explosions happening in lamps in which oil was used. The Doctor, having completed his experiments, tabulated the results of the same in an interesting communication to the Prussian Union for Promoting Trade Industries. The Doctor, among other things, said:

In a vessel holding petroleum the formation of a mixture with vapor of the maximum explosive power does not depend only on the temperature of the oil, but also on that of the wick impregnated therewith; this is not constant. In experiments on special explosive danger, glass vessels were used, provided with openings. The latter were closed with corks during the burning of the oil; and if an explosion was desired the cork was removed and an electric spark, or small flame, introduced. The strength of the resulting detonation measured the power of the explosion.

At first a second opening was provided to prevent the expected breaking of the vessel on explosion; but soon this was found to be superfluous, because in more than 1,500 trials the vessel was broken in only one instance, then due to imperfect thickness of sides.

If it be considered that, according to the theory, such an explosion creates a pressure of about 12 atmospheres, the fact seems strange, for such a glass vessel should at maximum be only able to sustain a pressure of 4 atmospheres, or 60 pounds per square inch. To clear up this it was necessary to discover whether in such explosions 12 to 14 atmospheres was really the amount of pressure. Experiments proved this was so, but also showed that if only a very small orifice was left, a considerable decrease of the pressure indicated was the result. That among so many trials no breakage occurred was also due to the small openings in the cover just around the wick protectors; also through the wick. Indeed, the latter was sufficient of itself, in many cases, to carry off the burning gases, and save the vessel from breakage; this was shown when the other openings were tightly closed. It should be here stated that risk of explosion, *per se*, is slight. It is otherwise with fire danger, or the so-called hot burning [overheating] of lamps, which may result in melting the protectors of wicks and breaking the lamps.

In this respect the two kinds of danger must be distinguished. On the one part is that of explosion, which impends when the temperature of the vessel approaches the so-called danger temperature, which is about 14° F. above the inflammation point of the oil on trial; on the other part is the fire danger, which consists in allowing the temperature of the oil vessel to exceed the so-called ignition temperature of the oil on trial to a degree about 22° F. above the inflammation point. The fire danger is as great as the explosive danger is small. Both would be greatly diminished if oils were used having the highest possible standard as to degrees of ignition and inflammation. Danger would also be considerably diminished if instead of glass lamps only those made of metal, stone ware, or hard rubber were used. Such would not only enable withstanding of greater pressure, but might prevent those explosions which occur through breaking of glass lamps upon their being dropped or overturned.

ITEMS OF INTEREST FROM VARIOUS LOCALITIES.

TO FURNISH ELECTRIC LIGHT.—On Aug. 19 the Massachusetts Board of Gas Commissioners granted the petition of the Clinton Gas Light Company, whose proprietors asked that they be allowed to furnish electric light to the inhabitants of Clinton and Lawrence. Mr. J. W. Corcoran appeared as counsel for the petitioners, and no objection was made to the petition. Mr. Corcoran, in his argument before the Board, stated that the arc electric lighting plant now existing in Clinton was to be purchased by the Gas Company.

IN DISGRACE.—The advertising columns of the Savannah (Ga.) *Morning News* recently contained a formal notice to the effect that T. B. Catherwood had been discharged from the service of the Mutual Gas Light Company of that city. Catherwood acted as collector for the Company, and it is said that his discharge resulted from inattention to business coupled with a discrepancy in his accounts. President Blun is reported to have said that Catherwood is something over \$1,000 behind in his obligations to the Company.

CHANGES AT ST. PAUL, MINN.—Having received several inquiries as to the significance of the change in the executive management of the St. Paul Gas Light Company, we herewith take occasion to say that the present board of officers is made up as follows: President, H. H. Sibley; Vice President and General Manager, Edward I. Frost; Secretary and Treasurer, W. Henry Patterson. From this arrangement it will be seen that the genial “Ed.” has been promoted; and thus is the true inwardness of the situation revealed.

THE JARVIS SYSTEM ADOPTED AT LAWRENCE, MASS.—The proprietors of the Lawrence Gas Light Company having decided to put in a complete and new steam plant, for the purpose of operating an electric lighting station in connection with their system of gas supply, instituted search for the method which would best meet their needs. Careful and prolonged examination of the subject induced them to award the palm of merit to the plan followed by the Charlestown Gas Light Company, and in consequence of that decision they have made a contract with the Jarvis Engineering Company, of Boston, Mass. The contractors are under orders to equip the Lawrence works with a complete steam plant, the same to include two Armington & Sims Company engines, and two boilers, to be set with the Jarvis boiler setting and Sheffield grates, which arrangement permits of the use of coke screenings for fuel. The

contract also calls for a National feed water heater, pump, injector, piping, and iron stack. Mr. Neal, of Charlestown, is thoroughly well satisfied with the working of the Jarvis system.

WATER, AND GAS, TOO, FOR SANFORD, ME.—The owners of the Sanford Electric Light Company have determined to branch out largely from their original purpose, for, at a stockholders' meeting held last month, it was decided to increase the capital stock and to so amend their charter that they will have the right to construct and operate both water and gas works. The water works project will be carried out first, and it is not likely that the gas plant will be constructed before the spring of '88.

THE ARTIFICIAL LIGHTING INDUSTRY OF NORRISTOWN, PA.—From what we presume is a transcript of the Norristown assessment rolls we learn the following concerning the artificial lighting industry of that flourishing place: The works of the Norristown Gas Company were erected in 1852, and the gas is distributed through 16 miles of pipes to the residents of Norristown and the adjacent town of Bridgeport. The buildings and machinery are of a substantial character, and the value of the plant, etc., is \$150,000. The capacity of the works can be depended on to supply a monthly output of about 15 millions cubic feet. Next comes the Norristown Electric Light and Power Company, which is officered as follows: President, I. H. Brendlinger; Sec. and Treas., W. F. Solly. The Company supplies both arc and incandescent lights, the Thomson Houston and the Edison systems being followed. No figures as to the value of the plant are given. The third occupant of the lighting field is the Norristown Electric Light, Heat, and Power Company, with S. P. Hanson as President; Dr. T. A. Foster, Secretary; and R. Sheetz, Treasurer. The Company employs the Excelsior system of electrical supply. The returns are silent on the value of the Company's property. Having read the above list, the conclusion must be reached that Norristown is abundantly supplied with dispensers of artificial light.

GEORGETOWN, COL., CHOOSES GAS.—At a regular meeting of the Georgetown City Council (held last month), when ordinary routine business had been disposed of, the Board went into executive session for the purpose of considering the bids that had been submitted by the gas and electric light companies for the public lighting of the town. The Georgetown Gas Company offered to supply gas to 44 lamps, on an annual lighting schedule of 3,600 hours, for the sum of \$71 per month. The Electric Light Company offered to maintain 44 lamps (20-candle power incandescents), to burn from the setting in of night to midnight, for the sum of \$61 per month. Both bidders agreed to do the work of lighting and extinguishing. The bids having been read, a motion was made that the Gas Company's bid be accepted, and that the contract be made to cover a period of three years, with the right to extend the same to five years. The motion was adopted.

NEW GAS COMPANY.—Local parties have secured a franchise for the operation of a gas works in the town of Riverside, California. The projectors say that the works will be ready to supply gas by Jan. 1, 1888. Riverside is a post village or town of San Bernardino county, Cal., on the Santa Ana river, and is about 7 miles from Colton station, on the So. Pacific Railroad. The latter place is 57 miles east of Los Angeles. It seems somewhat strange that a village which was only founded in 1870—we believe by a company of Massachusetts capitalists, who, appreciating the natural advantages of the locality in question, determined to enter upon the cultivation, on a large scale, of oranges, lemons, grapes, figs, etc.—can have gained that magnitude where a gas supply is necessary for the comfort of its residents; but, strange or otherwise, such seems to be the fact.

PASADENA, Los Angeles county, also has a gas company. The active man in its management is Mr. H. J. Roche, Secretary.

WHAT IS THE MATTER WITH THE LOCAL RULERS OF FORT MADISON, IA?—Having heard something which led us to believe that the public authorities of Fort Madison were acting in a most unaccountable and arbitrary manner towards those in charge of the gas supply of that city, and not caring to mention the particulars until we had positive confirmation that the rumors were based on facts, we addressed an inquiry to Mr. P. M. Hanley, Supt. of the Company, who very courteously returned the following reply:

“FORT MADISON, IOWA, Aug. 16, 1887.

“To the Editor AMERICAN GAS LIGHT JOURNAL: Your favor to hand, and noted. It is true we are having some trouble with our gas plant in Fort Madison, arising through the illegal interference of the city's Aldermen with our property and rights. The Council, on the information and advice of a few uninformed private citizens, who asserted that the

leakage (alleged) from the gas mains was killing the shade trees on the streets, passed a resolution declaring our works a nuisance. We were consequently served with a notice to at once cease manufacturing gas, and on our failure to do so the City Marshal was directed to remove the caps from the street lamps, and thus permit the gas to escape from the holders. We proceeded to refill the holders, whereupon our gas makers were arrested and jailed, without any proper or legal authority—in fact the proceeding has been illegal and unwarranted from beginning to end. This is a brief statement of the facts in the case. Our works are now shut down, and we will make no more gas until the damages to our business, for which we shall at once bring suit, are paid. We are, of course, manufacturing gas under a franchise which amply protects us. The fact that the shade trees not only continued to die on our pipe lines for nearly a month after our works were shut down, but that the trees in the town which are located a mile or more away from the pipe lines are also dying, does not increase the confidence of our Aldermen and citizens in the justice of their late high handed action.

“Yours, etc., P. M. HANLEY, Supt.”

Supt. Hanley's letter, which affords beyond doubt a just statement of the matter described, furnishes a unique contribution to the gas history of the country. High-handed action! Well, that hardly specifies it. But when the time of reckoning comes perhaps the Fort Madison tree-sparers will wish that they had looked before they leaped. We wish to thank Supt. Hanley for his courtesy to us in this matter.

SOMETHING WORTH REMEMBERING.—Printed matter may be copied on any paper of an absorbent nature by dampening the surface with a weak solution of acetate of iron and pressing in an ordinary copying press. Old writing may also be copied on unsized paper if wetted with a weak solution of sulphate of iron mixed with a simple solution of sugar syrup.

TO ENLARGE THE WORKS.—According to plans recently filed with the Building Department, the proprietors of the Fulton Municipal Gas Company, of Brooklyn, N. Y., will build a brick extension to their works located on the west side of Nevins street, between Sackett and Degraw streets. The betterments will involve the expenditure of about \$10,000. The contract for the mason work has been awarded to Mr. R. A. Deeves.

THE KELLER COKE CRUSHER.—We are in receipt of a handsomely-arranged circular and lithographic cardboard illustration descriptive of the C. M. Keller Adjustable Coke Crusher. A good machine sells readily, but we were hardly prepared to concede that Brother Keller's little giant had met with such widespread success; a success, however, that is in all respects deserved. The circular contains 23 testimonials as to the merit of the machine discussed, and of the 23 no less than 19 are from members of the gas fraternity, who cheerfully accord the crusher all praise. The machine is now furnished in four sizes, the classification being as follows: No. 0 is a coke crusher and coal breaker, as well; No. 1 may be employed on either oven or gas coke; No. 2 is intended for gas coke alone, as also is No. 3; but the latter is a hand power machine. There can be no doubt about the fact that a coke crushing machine is a valuable article to have in the gas works yard.

WESTERN WAIFS, BY “DIAPHRAGM.”—A hurried visit through parts of the Hoosier and Buckeye States proves that the gas men are busily engaged setting their houses in order. All speak hopefully of the future, and without exception report a pleasant increase in volume of business. With that preface let me say that General Manager Somerville, of Indianapolis, looks and feels decidedly better—the result of his recent visit to Europe. He has made many improvements at the works, and reports that the prospect of obtaining natural gas for Indianapolis remains in *statu quo*. Before piping in from a distance efforts are being made to find gas at a point nearer to the city. The chances of success are very poor.—Supt. Tracy, of Peru, Ind., has the new plant nearly completed. Fires will be lighted under the benches early this month, yet it will be a month later before he can say, “All is done.” When underway the Peru plant will be a model 6-inch specimen. The Kerr Murray Company furnishes all the iron work, the bench work being supplied by the Laclède folks. Arrangements have been perfected to install an electric light plant, and the American system has been chosen. The new departure ought to be ready for duty by the 15th inst. There has been quite a gratifying increase in the sendout this summer at Peru, due largely to Brother Tracy's success in placing a number of gas stoves this season. By-the-way, the steady and solid growth of the city augurs well for the future of the Peru Gas Company.—The electric light war at Lafayette, Ind., between the local company (Brush system) and the Gas Company (Thomson-Houston plan) wages merrily. The first named company has

offered to supply commercial lights at the extremely low figure of \$3 per month.—A new bench of 6's is being put up in the Crawfordsville plant, also over half a mile of new pipe has been added to the distributing plant. Besides these items Supt. Somerville has built for himself one of the handsomest residences in the city. The new home was to be "moved into" yesterday. Having fixed up the works, and thus made "things snug" for the demand of the coming long nights, Brother Somerville evidently intends to live a life of "ease and luxury" during the coming winter.—Supt. Hensley, of Hamilton, Ohio, after several months of hard work, has his plant in readiness for the coming season. His latest acquisition is an 8-inch Roots rotary exhauster. The old one—a 6-inch—goes to Fon du Lac, Wis. The Gas Company has taken the lighting of Hamilton into its own hands (as it should), and will have an electric plant in working order by the 15th inst. All attempts to find natural gas at Hamilton proved futile.—Edwin M. Starr has succeeded his father in the active management of the Richmond, Ind., works. The eagle eye of the "Governor," however, still scans the situation. Two new benches of 6's, fired on the regenerative plan, have been placed in the Richmond works this summer, while over a mile of main has been put underground, with another half mile yet to go down. The piano factory prospers, and in consequence the jolly (including avoirdupois) and deservedly popular Starr is transcendently happy. May he never wane!—Supt. Leefers, of Shelbyville, Ind., reports business as excellent and prospects very encouraging. They have vainly sought for natural gas. All hope of finding it has been abandoned.—Sec'y. Keller, of Columbus, Ind., was discovered in a happy state of mind. The business of furnishing light (electric and gas) is in a flourishing condition, whilst his unequaled coke crushers are being shipped all over the continent.—The genial Joe. Light, at Dayton, Ohio, gave your scribe a cordial welcome. His auxiliary (U. G. I. system) water gas plant is running, and to his satisfaction. Notwithstanding that an incandescent electric light plant was started early in the spring, the Gas Company's business has shown an unexpectedly large growth. The coke trade is a feature of the Dayton Company's business. Not a bushel of that valuable residual is in the yards, while orders are in hand for something like 35,000 bushels. A 16-inch Connelly governor has recently been ordered.—Supt. McNaughton has been quite successful in introducing gas stoves at Connersville, Ind. His city is growing steadily, and the Gas Company's business keeps pace therewith. He contemplates making extensive improvements to the Connersville works next season.—At Franklin, Ind., Supt. Woollen celebrated the completion of some new buildings with appropriate ceremonies. The Council recently ordered the Gas Company to erect 20 new lamp posts at various points in the city.

SECURING CONTROL.—The proprietors of the Meriden (Conn.) Gas Light Company have purchased a controlling interest in the stock of the Meriden Electric Light Company. The price paid has not been made public.

CHEAPER GAS FOR POUGHKEEPSIE, N. Y.—President Atwater, of the Poughkeepsie Gas Light Company, must be classed with those who believe in selling gas at a low rate, whereupon we congratulate Supt. Tracy, for the latter has always argued that cheap gas constitutes a bulwark of safety for the gas maker. According to the official announcement (published on August 25) the old Poughkeepsie Company agrees to supply consumers in accordance with the following schedule, the same to take effect on and after Sept. 1st:

Quarterly consumption.	Net rate per M.
8,000 cubic feet, or under.....	\$2.00
Over 8,000 cubic feet.....	1.25

NOT NEW TO THE NEW ORLEANS (LA.) GAS LIGHT COMPANY.—The following communication, from M. F. Carroll, Manager of the New Orleans Gas Light Company, explains itself: "Noticing the illustration and description of the Humphrys' Patent Damper Frame for Furnaces (p. 105, issue of JOURNAL for Aug. 16), I may state that for 26 years past our stack had a large central flue connected with tall chimneys. The flues of each bench were separately connected with the main flue, and all the regulating dampers for draught in the benches were arranged precisely as represented in the plan patented by Mr. Humphrys. We have at present in duty (it has been in use for over 30 years) a specimen of the device named which regulates the draught in a boiler furnace."

ALMOST READY.—Rapid progress is being made on the work of putting the finishing touches to the gas plant which is to supply gas to the people of Asheville, N. C. In fact it is hoped that the 15th inst. will witness the inauguration of the new departure.

GONE TO EUROPE.—Mr. Emil Lenz, the urbane and wideawake representative in this country of the "Stettiner Chamotte Fabrik Actien Gesellschaft," of Stettin, Germany, sailed for Europe, per steamship Fulda, on Aug. 27. Mr. Lenz expects to return shortly, and will bring back with him a specimen of the Stettin Company's machine for charging and drawing retorts. May wind and wave be favorable to the voyager.

ALLEGHENY COUNTY (PA.) GAS RECEIPTS.—According to a Pittsburgh authority a statement of the receipts of the illuminating gas companies doing business in Allegheny county, for the fiscal year 1886-7, has been filed in the office of the County Commissioner. That action is necessary to allow a *pro rata* assessment to provide for the payment of the salary and expenses of the County Gas Inspector, R. M. McKinney, which by law must be paid by the companies whose gas is examined. The Inspector's salary and expenses for the year just closed footed up to \$3,050 (salary, \$2,500; expenses, \$550), and providing for that amount necessitated the levying an assessment of 4 and 3.11 mills upon each dollar of receipts. The following table shows what each company contributed:

Name of Company.	Receipts.	Amount of Assessment.
East End.....	\$ 55,389.45	\$ 228.12
Braddock.....	6,158.80	26.31
South Side.....	54,770.05	234.02
Sharpsburg.....	4,806.89	20.54
West End.....	6,668.18	28.49
Allegheny.....	177,119.00	756.28
Pittsburgh.....	303,577.74	1,296.10
Sewickley.....	5,599.99	23.93
McKeesport.....	10,791.01	46.11
Consolidated.....	91,352.88	390.10
Totals.....	\$714,233.99	\$3,050.00

According to Inspector McKinney's last official report the illuminating values of the gas supplied by the different companies was as follows: Sewickley, 17.52; Braddock, 19.05; McKeesport, 16.43; Sharpsburg, 15.93; Allegheny, 20.20; Pittsburgh, 21; Consolidated, 18.18; East End, 19.04; South Side, 16.42; West End, 17.07.

LEASED.—The property of the Anderson (Ind.) Gas Light Company has been leased to the Anderson Natural Gas and Oil Company. The proprietors of the latter will hereafter supply Anderson with the light of the present.

THE PARKINSON THREE-PARTITION DRUM GAS METER.—The American Meter Company calls attention to the fact that it is now ready "to give estimates for new station meters, or rebuilding old station meters," on the Parkinson Three-Partition Drum plan. This Company is the sole licensee for the right to manufacture the Parkinson meter in the United States, and if the success which it has met with in England is to be the gauge of its popularity here, it will speedily find favor with American gas suppliers.

IMPROVEMENTS AT NORTH ADAMS, MASS.—Cheap gas seems to have made business lively with Brother Richardson, for he has added a bench of fives and a bench of threes to the North Adams plant. They will be fired with regenerative furnaces.

BROTHER GILBERT COMES DOWN ONCE MORE.—The following notice, which now appears in the Grand Rapids (Mich.) papers, tells the story of the determination that possesses the owners of the Grand Rapids Gas Company to reach, at no distant day, the point where gas will be sold at the dollar rate to all classes of consumers:

"The Gas Company announces its fifth annual reduction in the price of gas, to take effect on gas used after Jan. 1st, next, and to continue until further notice. To those who use 20,000 cubic feet of gas or over (through one meter) in one month, the price for that month will be:

	\$1.20 per M., gross.	\$1.00, net.
From 5,000 to 20,000....	1.50	1.20
" 1,000 to 5,000....	1.50	1.30
Less than 1,000.....	2.50	2.00

"This early notice is given in order that those who may be solicited to use some other method of lighting may act intelligently as to the plans and purposes of the Gas Company. By order of the Board of Directors, T. D. GILBERT, Secretary." Forewarned is forearmed, and the "warning" sounds possess the proper timbre.

FORMATION OF A CONSTRUCTION COMPANY.—Articles incorporating the Southern Gas Trust and Construction Company were recently filed

in the office of the County Clerk of Newark, N. J. Messrs. F. P. Mersereau, H. G. Payne and J. M. Dow were named as incorporators. The capital stock was placed at \$100,000, and the purport of the business is to be the construction and operation of gas and water works at various points in the State of Florida.

BONDED.—The Utica (N. Y.) Electric and Gas Company recently recorded a mortgage for \$150,000 on its property and franchise in favor of the Central Trust Company, of New York city, for the purpose of obtaining funds wherewith to complete the plant extensions now in progress.

PROGRESS AT COLUMBUS, OHIO.—A meeting of the stockholders of the Columbus Gas Light and Coke Company was held last month, the cause therefor being found in the desire to discuss the wisdom of a proposition to extend the corporate powers of the Company in the prosecution of its business. Several resolutions were submitted, the purport of same being to place the Company in position to supply electric light. Mr. Hubbard submitted a resolution asking that the Company be empowered to furnish gas for heating purposes. The resolutions were adopted unanimously, and Manager McMillin is likely to have few idle hours for many a day to come. In passing we might say that that table of comparative gas prices recently published by the Columbus Company carries its own story, the several chapters of which resulted, no doubt, from the researches made by "Mac" into the records of "Places where Gas is Sold at Bottom Prices." Our readers have already been told that Columbus is one of these places.

CHANGED HANDS.—A Springfield (Mass.) correspondent writes that Messrs. F. A. Sawyer, of Portland, Me., Col. Stedman, of New York, and Horace Woodman, of Biddeford, Me., have purchased the plant and franchises of the old Biddeford and Saco (Me.) Gas Light Company, and will take possession on the first of next month. He adds that in reality the purchasers have acted on behalf of the Traders Electric Light Company, of Biddeford, which is thus placed in control of the light supply of the city.

PUBLIC LIGHTING AT BATH, ME.—The Bath City Council has made a contract with the Bath Electric and Power Company whereby the latter is to maintain 20 high candle power arcs on the streets, the service to cost \$2,000 a year.

THE COLUMBUS (Miss.) Gas works will be enlarged.

KILLED BY THE ELECTRIC CURRENT.—At an early hour on the morning of Aug. 13, Frank Young, an employe of the Brush Electric Light Company, of New Orleans, La., while engaged in repairing a defective wire, was instantly killed by an electric shock. Deceased was caught and held by the wires, his body remaining suspended in mid-air until his companions caused the current to be shut down so that they could ascend the pole in safety to remove the body to the street.

POOR RENO, NEVADA.—Reno has a grievance, and it is like this. The local electric lighting plant derives its power from the Truckee river, but somebody above their wheel shuts down a dam during the night for the purpose of sending a raft of logs down the river "with a rush" on the following morning. In this manner the log rollers extinguish Reno's public lights, and the Reno Council insists that the electricians must put in a steam plant. Why not jail the log rollers?

CHEAPER GAS FOR CHATTANOOGA, TENN.—At a recent meeting of the Chattanooga Gas Light Company's Directors it was resolved to reduce the price of gas in accordance with the following schedule: Gross, \$1.70 per 1,000 cu. ft., with 10 cents off on all monthly bills over \$40 and under \$100, that concession to be doubled on bills over \$100. A meter rent of 25 cents per month is to be charged where the monthly consumption fails to reach 200 cubic feet. Prior rate, \$2 per 1,000.

CONSOLIDATED.—The Stillwater (Minn.) Gas Light Company has been consolidated with the local electric light company. The new title of the incorporation has, therefore, been changed to that of the Stillwater Gas and Electric Light Company. The capital stock is \$60,000.

BONDING THE WASHINGTON (D. C.) GAS LIGHT COMPANY.—According to the *Washington Republican*, "A deed of trust has been made of record at the Recorder's Office, given by C. G. Grover and C. A. James, on all the Company's real and personal property to secure the payment of \$1,000,000. The deed declares that at a meeting of the Board of Directors, held on June 4, it was decided that such action should be taken in order to provide additional facilities for the business of the

Company, by the erection of suitable structures in square 1025, and in squares south of 1025, south of M street, between 12th and 13th streets, east, etc." It is further declared that the extension of the plant has become a necessity, because the consumption of gas has almost reached the capacity of the present works, and no available ground exists for the Company's purpose at the existent G street station. The bonds are to be graded in \$100, \$500, and \$1,000, are to bear interest at the rate of 6 per cent., and are made payable at the expiration of 40 years, but may be redeemed after 15 years.

It is asserted that a large issue of bonds is to be made by the Chicago (Ills.) Gas Trnst, the proceeds of the same to be devoted to plant betterment on a grand scale.

TROUBLE OVER METER RENT CHARGES, ETC.—The New Orleans (La.) Gas Light Company has notified those of its consumers who are also using electric lights that hereafter, "when the amount of the deposit left with the Company, as a guarantee for the payment of the bill and the safe return of the meter, covers more than the average monthly bill, notice is to be sent to the consumer to present his certificate at the office of the Company, when the original deposit will be refunded and a new one, proportioned to the actual monthly consumption of gas, will be issued in place of the original." Further, the Company has decided to charge the same class of light users a meter rental where the consumer insists on retaining a meter the size of which is in excess of the actual needs of the consumer as shown by his average monthly gas bills. That tariff is adjusted as follows: 150-light, \$3 per month; 100-light, \$2; 80-light, \$1.75; 45-light, \$1.50; 30-light, \$1.25; 20-light, 75 cents; 10-light, 50 cents; 5-light, 25 cents. A consumer named Jackson has brought suit in Civil Court for an injunction to restrain the Company from carrying the rules into effect. This will bring the matter to proper legal test; and we incline to the view that the Courts will eventually uphold the Gas Company's course as being within the limit of the law.

AT THE NEW HAMPSHIRE STATE HOUSE.—On Aug. 25 the House Committee on Incorporations of the New Hampshire Legislature, now in session, held a hearing on the petition asking for a charter for a new gas company for the city of Manchester. The hearing attracted much attention, and several representative citizens addressed the Committee. Of course the views of the speakers differed widely, or in accordance with the way in which their interests swayed them. No determination was arrived at.

Regulating the Speed of Engines for Driving Dynamos.

M. Menges, who has devoted much consideration to the subject, calls attention to a device that he has perfected for regulating the speed of gas and other engines employed in driving dynamos. By the Menges method the supply of gas to the motor is controlled electrically by means of a solenoid coupled up with the lamps, either in series or in parallel, according as a constant potential or a constant current service is required. A soft iron core is placed in the solenoid, and any variation of the current in the latter causes a corresponding change in the position of the core. The core is connected by a lever to the gas valve, the opening through which is thus varied *pari passu* with the current through the coil. This is so arranged that the greater the load on the dynamo the wider is the gas valve opened, with the curious result that the speed of the engine is greater under high loads than under low.

Generator Furnaces for Small Gas Works.

In editorially commenting on the experience gained in the above direction, by Mr. T. Blyth, of the Kingskettle gas works (who communicated his findings in the premises in the shape of a paper, read at the last meeting of the North British Association of Gas Managers), the *London Journal* says: "From it [Mr. Blyth's paper] we gather ample evidence of the power which is now at the command of every gas manager, however small the scale of his works, to improve his methods of carbonization by the aid of the gas generator furnaces. The idea that this class of furnace, with all that is necessary in the way of heated air supply for the secondary combustion, must be beyond the means and understanding of managers of small works never received any countenance in these columns, and must be regarded as exploded by the recorded statements of such witnesses as Mr. Blyth, of Kingskettle, and Mr. Turnbull, of Lauder. It is now conclusively shown that, for the expenditure of a very little money and a not stupendous amount of brain power, the best benefits of gaseous firing may be secured by a man who does all his own work in summer, and only has another man to help him in winter. In this, as in most other things, it is the head that saves the hands. The painstaking and intelligent working manager can find in the gas furnace the means to spare his own labor and to do better for his employers; while the careless, dull, or uninterested engineer of a huge undertaking may go on in the ways taught to him by his dead-and-gone master in days when the name of Siemens was unknown. It is the former, however, who are more deserving of honor among their fellows."



A. M. CALLENDER & CO.,

PROPRIETORS.

Editor—JOS. R. THOMAS, C.E.

Asst. Editor—T. J. CUNNINGHAM.

Manager—C. E. SANDERSON.

PUBLISHED ON THE 2ND AND 16TH OF EACH MONTH
At No. 42 Pine Street, New York.

This is a recognized official organ of—

LIGHT, HEAT, STEAM, WATER-SUPPLY,
VENTILATION, SANITARY IMPROVEMENT,
AND GENERAL SCIENCE.

TERMS

SUBSCRIPTION—Three Dollars per annum, in advance.

AGENTS

NEW YORK—AMERICAN NEWS Co. 39 and 41 Chambers St.

BOSTON—S. M. PETTENGILL & Co., 6 State Street.

PHILADELPHIA—PRATT & Co., Corner 9th and Arch Streets.

England—C. W. HASTINGS, 22 Buckingham St., London, W.C.

Germany—B. WESTERMANN & Co., of New York

FRIDAY, SEPT. 2, 1887.

Painting Ironwork.

A writer in the *Plumber's Review* says when ironwork has to be painted the engineer has a task to perform. Cast and wrought iron behave very differently under atmospheric influences, and require somewhat different treatment. The decay of iron becomes very marked in certain situations, and weakens the metal in direct proportion to the depth to which it has penetrated, and although where the metal is in quantity this is not very appreciable, it really becomes so when the metal is under $\frac{3}{4}$ -inch in thickness. The natural surface of cast iron is very much harder than the interior, occasioned by its becoming chilled, or by its containing a large quantity of silica, and affords an excellent natural protection, but should this surface be broken rust attacks the metal and soon destroys it. It is very desirable that the casting be protected as soon after it leaves the mould as possible, and a priming coat of paint should be applied for this purpose; the other coats thought requisite can be given at leisure. In considering the painting of wrought iron it must be noticed that when iron is oxidized by contact with the atmosphere two or three distinct layers of scale form on the surface, which, unlike the skin upon cast iron, can be readily detached by bending or hammering the metal. It will be seen that the iron has a tendency to rust from the moment it leaves the hammer or rolls, and the scale above described must come away. One of the plans to preserve iron has been to coat it with paint when still hot at the mill; and although this answers for a while, it is a very troublesome method, which ironmasters cannot be persuaded to adopt, and the subsequent cutting processes to which it is submitted leave many parts of the iron bare. Besides, a good deal of the scale remains, and until this has fallen off or been removed any painting over it will be of little value. The

only effectual way of preparing wrought iron is to effect a thorough and chemical cleansing of the surface of the metal upon which the paint is to be applied; that is, it must be immersed for three or four hours in water containing from 1 to 2 per cent. of sulphuric acid. The metal is afterwards rinsed in cold water, and, if necessary, scoured with sand, put again into the pickle, and then well rinsed. If it is desired to keep iron already cleansed for a short time before painting it is necessary to preserve it in a bath rendered alkaline by caustic lime, potash, soda, or their carbonates. Treatment with caustic lime water is, however, the cheapest and most easy method, and iron which has remained in it some hours will not rust by a slight exposure to a damp atmosphere. Having obtained a clean surface the question arises, What paint should be used upon iron? Bituminous paints, as well as those containing variable quantities of lead, were formerly considered as solely available, but their failure was made apparent when the structures to which they were applied happened to be of magnitude, subjected to great inclemency of weather, or to constant vibration. Recourse has, therefore, been had to iron oxide itself, and with satisfactory results. A pound of iron oxide paint, when mixed ready for use in the proportions of two-thirds oxide to one-third linseed oil, with careful work, should cover 21 square yards of sheet iron, which is more than is obtained with lead compound. Oxide of iron paint endures a very great heat without material alteration, and keeps both its color and preservative qualities well. There is this difference to be noticed between painting of iron and wood—that with the former, when the painter comes to spots of rust that cannot be removed, he should endeavor to incorporate them with the paint rather than paint over them. The repainting of iron involves carefully washing down and removing all dust, dirt and so on from the entire surface, every particle of rust being scraped and chipped off, the work receiving from two to four coats in oil, properly applied. The real value of any paint depends on the quality of the linseed oil, the quality and character of the pigment, and the care bestowed on grinding and mixing, and as all this is entirely a matter of expense, cheap paints are not to be relied upon.

The Market for Gas Securities.

The record of the market for city gas shares during the fortnight presents but little that is comforting to investors in such securities, and there is absolutely no reason for the downward tendency that has characterized the tradings. The general share market seems for the time being to be completely under control of the bearish element, but operators on the short side only court disaster when they play fast and loose with a property of the sort represented by the plant and franchises of the Consolidated Gas Light Company. To-day Consolidated is quoted at 72½, whereas a twelvemonth ago it was rated worth 80½. Taking into account every factor involved in the situation, there can be no doubt but that the Company is in all respects stronger now than it was a year ago. The vagaries of the stock market, however, are little short of inexplicable, but the eccentricity of that mart cannot affect the intrinsic value of the shares sold thereon, in the long run at all events. Those who buy Consolidated at 80 or under cannot make a mistake in so doing. Other city

shares are dull, but the next month will note a decided change. Williamsburgh gas looks like a purchase.

The annual meeting of the stockholders of the Providence (R. I.) Company will be held next week, and the showing for the year will be apt to surprise some of its shareowners. It was predicted not long ago that the local electric lighting company would make an inroad on the Gas Company's sales; but advices recently received from there state that "some of the results of the general introduction of electric lighting into this city have been a decided increase in the quantity of gas burned in competition, especially in shops, show windows, etc." The out-of-town situation presents nothing of particular interest.

Gas Stocks.

Quotations by Geo. W. Close, Broker and Dealer in Gas Stocks.

16 WALL ST., NEW YORK CITY.

SEPTEMBER 2.

All communications will receive particular attention.
The following quotations are based on the par value of \$100 per share.

	Capital.	Par.	Bid	Asked
Consolidated.....	\$35,430,000	100	72½	73
Central.....	440,000	50	30	—
“ Scrip.....	220,000	—	47	57
Equitable.....	2,000,000	100	—	120
“ Bonds.....	1,000,000	—	113	115
Harlem, Bonds.....	170,000	—	—	—
Metropolitan, Bonds....	658,000	—	110	113
Mutual.....	3,500,000	100	92	94
“ Bonds.....	1,500,000	1000	101	—
Municipal, Bonds.....	750,000	—	—	—
Northern.....	125,000	50	30	—
“ Scrip.....	108,000	—	—	—
Yonkers.....	—	50	—	80
Richmond Co., S. I.	300,000	50	50	—
“ Bonds.....	12,000	—	—	—
Gas Co's of Brooklyn.				
Brooklyn.....	2,000,000	25	100	102
Citizens.....	1,200,000	20	—	57
“ S. F. Bonds....	320,000	1000	—	103
Fulton Municipal.....	3,000,000	100	132	135
“ Bonds....	300,000	—	—	106
Peoples.....	1,000,000	10	58	61
“ Bonds (5's).....	368,000	—	97	—
“ “ (6's).....	94,000	—	100	—
Metropolitan.....	1,000,000	100	78	80
Nassau.....	1,000,000	25	100	104
“ Cts.....	700,000	1000	100	—
Williamsburgh.....	1,000,000	50	115	120
“ Bonds... ..	1,000,000	—	111	—
Out of Town Gas Companies.				
Boston (Mass.) Gas Co.	2,500,000	500	204	208
Buffalo Mutual, N. Y....	750,000	100	90	95
“ Bonds... ..	200,000	1000	95	100
Citizens, Newark.....	1,000,000	50	140	145
“ Bonds.....	45,000	—	—	—
Chicago Gas Trust.....	25,000,000	100	45	50
Cincinnati G. & C. Co..	6,000,000	100	187	188
Consolidated, Balt.....	6,000,000	100	54	56
“ Bonds....	3,600,000	—	107	107½
Chesapeake, Balt.....	1,500,000	100	—	75
“	1,000,000	—	100	102
Consumers Toronto....	1,000,000	50	192	—
Central, S. F., Cal.....	—	—	80	100
Capital, Sacramento, Cal.	—	—	57½	60
Hartford, Conn.....	750,000	25	140	142
Jersey City.....	750,000	20	168	—
Laclede, St. Louis, Mo.	2,000,000	100	125	—
Louisville, Ky.....	2,570,000	50	130	132
Little Falls, N. Y.....	50,000	100	95	100
“ Bonds.....	25,000	—	100	103
Montreal, Canada.....	2,000,000	100	220	221
Memphis (Tenn.) Gas... ..	750,000	100	—	—
“ Bonds.....	240,000	100	103	—
New Haven, Conn.....	—	25	193	197
Oakland, Cal.....	—	—	87	37½
Peoples, Jersey City... ..	—	—	60	—
“ “ Bonds..	—	—	—	—

Washington, D. C.....	2,000,000	20	210	—
Wilmington, Del.....		50	200	208
Havana (Cuba) Gas Co.	3,000,000	100	18	20
“ Bonds.....	550,000		102	—

Advertisers Index.

GAS ENGINEERS.		Page
Jos. R. Thomas, New York City.....		152
Wm. Henry White, New York City.....		152
Wm. Mooney, New York City.....		152
William Gardner, Pittsburgh, Pa.....		152
GAS WORKS APPARATUS AND CONSTRUCTION.		
James R. Floyd, New York City.....		155
T. F. Rowland, Greenpoint, L. I.....		155
Delly & Fowler, Phila., Pa.....		155
Kerr Murray Mfg. Co., Fort Wayne, Ind.....		154
Stacey Mfg. Co., Cincinnati, Ohio.....		155
Bartlett, Hayward & Co., Baltimore, Md.....		145
Morris, Tasker & Co., Limited, Phila., Pa.....		154
Davis & Farnum Mfg. Co., Waltham, Mass.....		144
R. D. Wood & Co., Phila., Pa.....		151
Southwark Foundry and Machine Co., Philadelphia, Pa.....		154
Bouton Foundry Co., Chicago, Ills.....		151
Smith & Sayre Manufacturing Co., New York City.....		155
PROCESSES.		
National Gas Light and Fuel Co., Chicago Ills.....		146
GAS AND WATER PIPES.		
Gloucester Iron Works, Phila., Pa.....		152
Mellert Foundry and Machine Co., Reading, Pa. (John Fox, Selling Agent, N. Y.).....		152
Cincinnati and Newport Iron and Pipe Co., Newport, Ky.....		152
Ohio Pipe Co., Columbus, Ohio.....		152
Pancoast & Rogers, New York City.....		152
M. J. Drummond, New York City.....		152
Wells Rustless Iron Co., New York City.....		151
R. D. Wood & Co., Phila., Pa.....		154
GAS ENGINES.		
Schleicher, Schumm & Co., Phila., Pa.....		128
Clerk Gas Engine Co., Phila., Pa.....		147
RETORTS AND FIRE BRICK.		
J. H. Gautier & Co., Jersey City, N. J.....		150
B. Kreisler & Sons, New York City.....		150
Adam Weber, New York City.....		150
Laclede Fire Brick Works, St. Louis, Mo.....		150
Brooklyn Retort and Fire Brick Works, Brooklyn, N. Y.....		150
Borgner & O'Brien, Phila., Pa.....		150
James Gardner, Jr., Pittsburgh, Pa.....		150
Henry Maurer & Son, New York City.....		150
Chicago Retort and Fire Brick Works, Chicago, Ills.....		150
Baltimore Retort and Fire Brick Co., Baltimore.....		150
Oakhill Gas Retort and Fire Brick Co., St. Louis, Mo.....		150
Evens & Howard, St. Louis, Mo.....		151
Cincinnati Gas Retort and Fire Brick Works, Cincinnati, O.....		151
Emil Lenz, New York City.....		151
SCRUBBERS AND CONDENSERS.		
G. Shepard Page, New York City.....		153
R. D. Wood & Co., Phila., Pa.....		154
REGENERATIVE FURNACES.		
Bartlett, Hayward & Co., Baltimore, Md.....		145
Fred. Bredel, New York City.....		151
GAS GOVERNORS.		
T. C. Hopper, Phila., Pa.....		148
Connelly & Co., New York City.....		147

CEMENTS.		
C. L. Gerould, Manchester, N. H.....		150
GAS ENRICHERS.		
Standard Oil Co., Cleveland, Ohio.....		156
GAS METERS.		
Harris, Griffin & Co., Phila., Pa.....		158
American Meter Co., New York and Philadelphia.....		159
The Goodwin Gas Stove and Meter Co., Philadelphia, Pa.....		159
Heime & McIlhenny, Phila., Pa.....		159
D. McDonald & Co., Albany, N. Y.....		159
Nathaniel Tufts, Boston, Mass.....		158
EXHAUSTERS.		
P. H. & F. M. Roots, Connersville, Ind.....		146
Smith & Sayre Manufacturing Co., New York City.....		155
Wilbraham Bros., Philadelphia, Pa.....		147
Connelly & Co., New York City.....		147
GAS COALS.		
Penn Gas Coal Co., Phila., Pa.....		157
Perkins & Co., New York City.....		156
Newburgh Orrel Coal Co., Baltimore Md.....		157
Despard Coal Co., Baltimore, Md.....		157
Chesapeake and Ohio R.R. Coal Agency, N. Y. City.....		157
Westmoreland Coal Company, Phila., Pa.....		157
Monongahela & Peters Creek Gas Coal Co., Pittsburgh, Pa.....		157
CANNEL COALS.		
Perkins & Co., New York City.....		156
J. & W. Wood, New York City.....		156
VALVES.		
Ludlow Valve Manufacturing Co., Troy, N. Y.....		148
John McLean, New York City.....		148
Chapman Valve Manufacturing Co., Boston, Mass.....		148
R. D. Wood & Co., Phila., Pa.....		154
ENGINES AND BOILERS.		
Jarvis Engineering Co., Boston, Mass.....		147
PURIFYING MATERIAL.		
S. H. Douglas, Ann Arbor, Mich.....		151
Connelly & Co., New York City.....		147
GAS LAMPS.		
The Siemens-Lungren Co., Philadelphia, Pa.....		153
G. Shepard Page, New York City.....		152
Albo-Carbon Light Co., Newark, N. J.....		143
Standard Gas Lamp Co., Phila., Pa.....		151
PURIFIER SCREENS.		
John Cabot, New York City.....		119
Geo. A. Mills, Baltimore, Md.....		151
GAS STOVES.		
American Meter Co., New York and Philadelphia.....		149
The Goodwin Gas Stove and Meter Co., Phila. Pa.....		160
STREET LAMPS.		
J. G. Miner, Morrisania, New York City.....		111
Bartlett Street Lamp Mfg Co., New York City.....		148
BURNERS.		
C. A. Gefroerer, Phila., Pa.....		156
STEAM BLOWER FOR BURNING BREESE.		
H. E. Parson, New York City.....		120
GASHOLDER TANKS.		
W. C. Whyte, New York City.....		151
GAS FIXTURES.		
Mitchell, Vance & Co., New York City.....		148

COKE CRUSHER.		
C. M. Keller, Columbus, Ind.....		157
GAS BAGS.		
Peerless Manuf'g Co., New York City.....		147
ELECTRICAL APPARATUS.		
Waterhouse Electric & Manufg Co., Hartford, Conn.....		144
BOOKS, ETC.		
English Journal of Gas Lighting.....		143
Gas as a Source of Light, Heat and Power.....		148
Goodwin's Directory of Gas Light Companies.....		156
King's Treatise.....		158
Scientific Books.....		158
Management of Small Gas Works.....		152
Newhigging's Gas Manager's Handbook.....		158
Gas vs. Electricity.....		155

Engagement Desired
AS SUPERINTENDENT OF SMALL GAS WORKS,
 By a practical, live man of 20 years' experience in the manufacture and distribution of coal and water gas in all branches. Satisfactory references given. Address "V. E.," care this Office.

Position Desired.
 A man of correct habits desires a position
As Superintendent, Engineer, or Constructor of Gas Works.
 Thoroughly understands water gas processes, as well as coal, oil, or wood gas. Perfectly familiar with the erection of gas works in every detail; also designing, drawing, analysis, photometry, etc. Will take a non-paying works and put it on a paying basis; or take charge of the erection of a works and manage it after completion. Address
 676-2 "G. A. S.," care this Journal.

Engagement Desired.
 The advertiser, an English Gas Engineer, age 25, seeks an engagement
As Gas Works Manager or Assistant Manager.
 Thoroughly understands the manufacture and distribution of gas, and is a good draughtsman and chemist. Address
 672-6t "H." care this Office.

FOR SALE,
Two Sinuous Friction Condensers,
 Each 1 ft. 3 in. wide by 11 ft. 3 in. long, and 18 ft. high, of sufficient capacity for 225,000 cu. ft. per day. Apply to
 665-12 PETER COFFEY, Supt. Gas Co., Peoria, Ill.

ENGLISH
"Journal of Gas Lighting."
 Issued weekly. New volume commences Jan. 1, 1887. Price, \$7 per annum. Subscriptions taken by
CHARLES NETTLETON, Agent for U. S.,
 No. 115 BROADWAY, N. Y. CITY.

THE ALBO-CARBON LIGHT.



THIS SYSTEM HAS SHOWN ITSELF IN THOUSANDS OF CASES—IN HALLS, CHURCHES, PICTURE GALLERIES, CONCERT HALLS, RESTAURANTS, BANKS, CLUBS, STORES, OFFICES, and PRIVATE RESIDENCES—TO BE THE

Best Adapted and Most Successful Method of Gas Lighting Ever Offered.

The **SOFTNESS AND PURITY OF THE LIGHT** make it most desirable for Office and Household Uses. Its **BRILLIANCY** and **POWER** render it unrivaled for lighting Halls, Churches, etc. Its **ECONOMY** secures for it general favor wherever used.

NOTICE.—Suits are pending in the United States Circuit Courts in Illinois and Pennsylvania against various parties for infringement of our Letters Patent No. 247,925, dated October 4, 1881, and No. 333,862, dated January 5, 1886. The first of these suits has come up for hearing, and an injunction has been granted therein. The second of said suits has not yet been reached for hearing. All persons are cautioned against manufacturing, selling, or using any apparatus or material which infringes our patents. We intend to prosecute all parties infringing patents owned by us.

ALBO-CARBON LIGHT CO. (Sole Manufacturers for the United States) Main Office, Newark, N. J.

ARC AND INCANDESCENT LIGHTING.

**Steady Lights, Economy of Power,
INSTANTANEOUS AUTOMATIC REGULATION,**

ARE ALL CONTAINED IN

THE WATERHOUSE SYSTEM

A Complete System that will knock out competition and secure the trade. We invite the most critical investigation, as we have no "outs" to apologize for.

Send for Catalogue!

Send for Catalogue!

THE WATERHOUSE ELECTRIC AND MFG. COMPANY,
Factory, Colt's West Armory. **Hartford, Conn.**

To All Whom It May Concern!

The SIEMENS-LUNGREN COMPANY hereby warns the public against the use of various infringing Regenerative Gas Lamps which are offered for sale. This Company has heretofore delayed bringing suit to enjoin the manufacture or importation of such infringing lamps, solely because of the practical worthlessness of the infringing devices; and although, in each instance, they infringe some one or more of the various patents owned or controlled by this Company, they have fallen into disuse sooner than any suit could be brought to a hearing. As, however, the introduction of these infringing lamps has tended to discredit the practicability of our Company's system of regenerative gas lighting, we have instructed our Attorneys Messrs. Geo. Harding, C. S. Whitman, and Silas W. Pettit, to give notice that legal proceedings will in future be taken against all such infringers.

THE SIEMENS-LUNGREN CO., 21st St. & Washington Av., Phila., Pa.

F. J. DAVIS & J. R. FARNUM,

TRUSTEES AND AGENTS FOR THE

SINUOUS FRICTION CONDENSER.

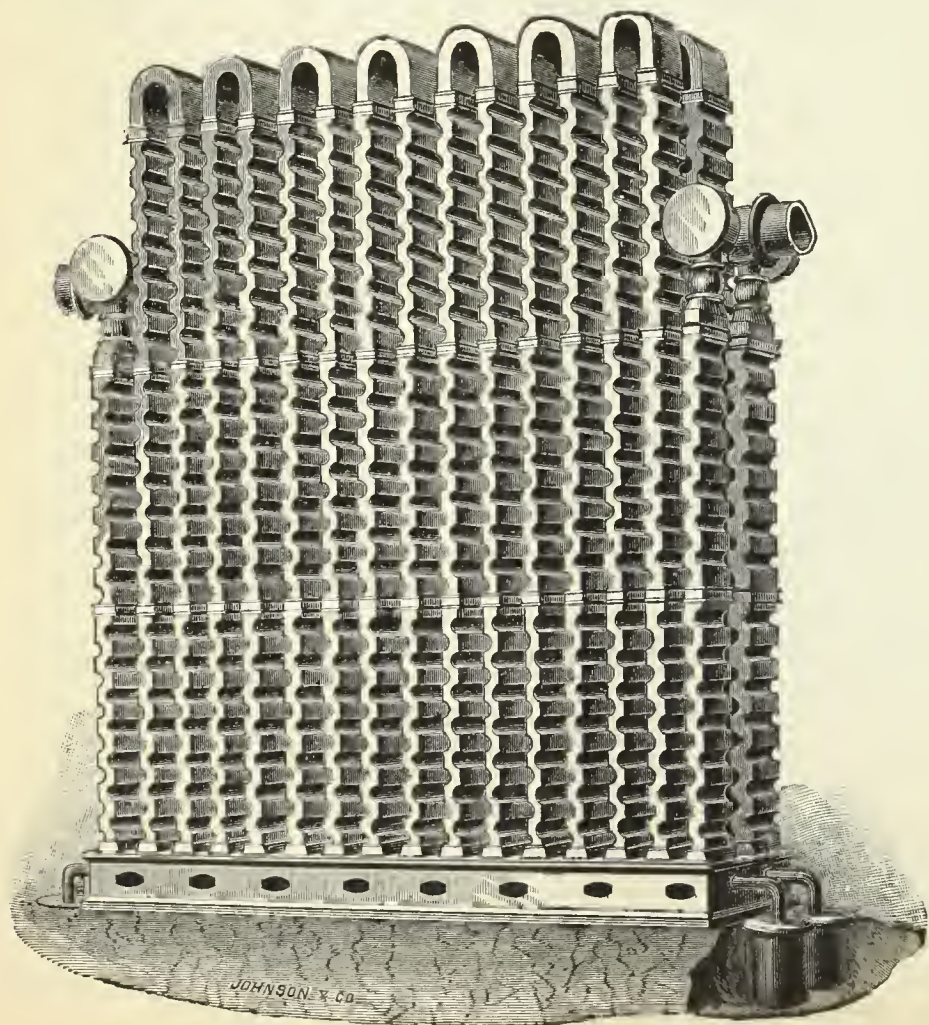

We desire to draw the attention of the gas community to the merits of the SINUOUS FRICTION CONDENSER. Companies intending to introduce new condensers into their works will do well to confer with us and examine plans and estimates before contracting for any other pattern. The FRICTION CONDENSER is now in use at the gas works located in the following places:

Portland, Me.	Brookline, Mass.	Pawtucket, R. I.	Frederickton, N. B.
Newport, R. I.	Chelsea, Mass.	Jamaica Plain, Mass.	St. John, N. B.
Gloucester, Mass.	Woburn, Mass.	Attleboro, Mass.	Paterson, N. J.
Newton & Water- town, Mass.	Peoria, Ill.	Calals, Me.	Dover, N. H.
	Clinton, Mass.	Fall River, Mass.	Waltham, Mass.
		Nassau Works, Brooklyn, N. Y.	

DAVIS & FARNUM MFG. CO.

MANUFACTURERS OF

Gas and Water Pipes,

AND

GAS AND WATER MACHINERY

OF THE MOST APPROVED PATTERN.

Also, Gasholders and Iron Roofing.

Orders from Gas and Water Companies promptly attended to.

WALTHAM, MASS.

Boston Office, Room 55, Mason Building, 70 Kilby Street.

BARTLETT, HAYWARD & CO.

Baltimore, Md.

Munich Regenerative Furnace, System Drs. Schilling & Bunte.

Greatest durability; minimum of attention; complete distillation in 3½ hours; 10 to 13 pounds of coke to hundred-weight of coal; no clinker; no carbonic oxide in regenerative flues.

TWO AND THREE-LIFT TELESCOPIC GASHOLDERS,

With Wrought Iron Tanks, constructed above ground, of any magnitude.

Condensers, Scrubbers, Purifiers, Bench Castings, Roofs, Boilers, Etc.

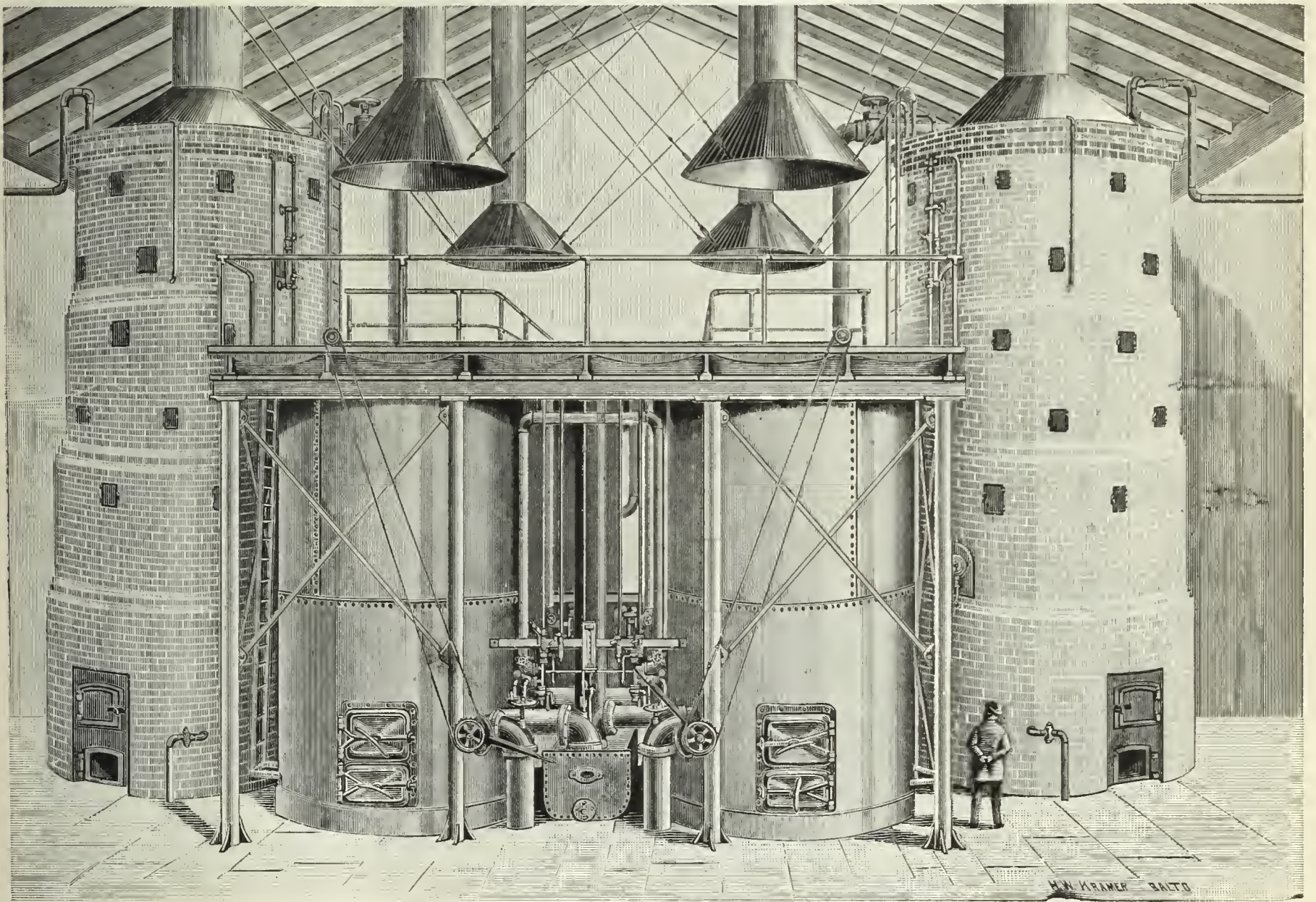

The Wilkinson Water Gas Process.

Introducing the Munich Regenerative Furnace for Coal Gas, we find on the part of many Gas Companies the desire to combine to a greater or less extent an efficient system of making high candle power Water Gas; and with a view of enabling this to be done WITHOUT EXCESSIVE CHARGES FOR PATENT RIGHTS, ETC., we have acquired, by purchase, the exclusive right to construct all the Water Gas Apparatus under the valuable "Wilkinson" Patents.

The results obtained by this Process are far better than those obtained by any other apparatus, especially where an illuminating gas of high candle power or a fuel gas of intense temperature is required.

The Process is uninterrupted, making gas of uniform quality and quantity. Its greatest advantages are maximum production with minimum material and labor, combined with great durability of apparatus.

The Process is in successful operation at the works of the N. Y. Mutual Gas Company, New York; Consolidated Gas Company, Baltimore, Md.; the Hudson County Gas Light Company, of Hoboken, N. J.; and at Rye, N. Y.

We shall be glad to give further detailed information upon application.

Sole Agents for the Celebrated Hazelton Boiler.

BARTLETT, HAYWARD & CO.

EXHAUSTERS.

EXHAUSTERS.

PROCESSES.

ROOTS' NEW GAS EXHAUSTER.

St. Louis, Mo.,
March 21, 1887.

Messrs. P. H. & F. M. Roots, Connorsville, Ind.:
Dear Sirs—In 1872 one of your No. 5 Exhausters was placed in these works, and worked satisfactorily. In March, 1885, it was replaced by one of your No. 6 Exhausters. The latter has been in almost constant use the past two years, has worked up to all my expectations, and is to-day in apparently as good condition as when first set up. It has not cost one cent for repairs in all that time. I have also

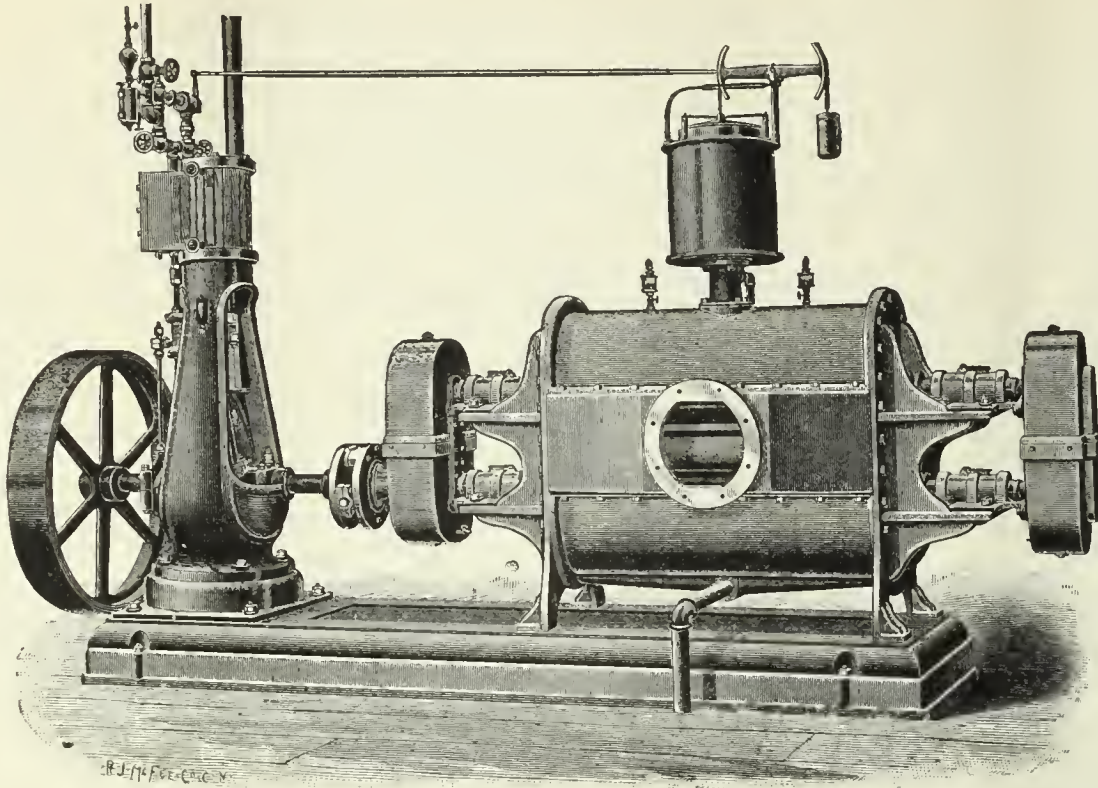

had one of your No. 1 Exhausters, with Engine on same bed-plate, fitted with your valves and Huntoon Governor, placed in a small works under my control, and in its operation it seems as near perfection as I ever expect an Exhauster to become. Without in the least disparaging Exhausters of other makes, I may say that your Exhauster may be safely recommended as unsurpassed by any other, to those requiring such machines.

Yours respectfully,
FREDERIC EGNER,
Eng. and Supt.

CONSTRUCTED ON ENTIRELY NEW PRINCIPLES.

THE ONLY EXHAUSTER MADE IN WHICH

The Internal Operating Parts Consist of Only Two Pieces, Each Cast Entire in One Piece.

Send for Descriptive Catalogue and Price List.

P. H. & F. M. ROOTS, Patentees and Manufacturers, **CONNERSVILLE, IND.**

S. S. TOWNSEND, Gen. Agt., 22 Cortlandt St., N. Y. COOKE & CO., Selling Agts., 22 Cortlandt St., N. Y.

DURING THE PAST YEAR, THE

NATIONAL GAS LIGHT AND FUEL CO.

218 LA SALLE ST., CHICAGO,

Have Erected Twelve Sets of Water Gas Generating Apparatus under the *Springer Cupola* System. They are as follows:

Newton Illuminating Company, Newton, Kansas.— Daily capacity, 120,000 cu. ft.

Wellington Light & Heat Co., Wellington, Kansas.— Daily capacity, 120,000 cu. ft.

Chippewa Falls, Gas Light Co., Chippewa Falls, Wis.— Daily capacity, 120,000 cu. ft.

Elkhart Gas Light & Coke Co., Elkhart, Indiana.— Daily capacity, 120,000 cu. ft.

Madison City Gas Light Company, Madison, Wis.— Daily capacity, 120,000 cu. ft.

South Bend Gas Light Co., South Bend, Indiana.— Daily capacity, 250,000 cu. ft.

Sheboygan National Gas Comp'y, Sheboygan, Wis.— Daily capacity, 120,000 cu. ft.

Salina Gas Light Company, Salina, Kansas.— Daily capacity, 120,000 cu. ft.

Rathbun Company, Deseronto, Province Ontario.— Daily capacity, 80,000 cu. ft.

Jefferson City Gas Light Co., Jefferson City, Mo.— Daily capacity, 120,000 cu. ft.

Mankato Gas Light Company, Mankato, Minnesota.— Daily capacity, 80,000 cu. ft.

Minneapolis Gas Lt. & Coke Co., Minneapolis, Minn.— Daily capacity, 1,000,000 cu. ft.

1886

1886

CONNELLY & CO., LTD.,

SOLE MANUFACTURERS OF THEIR PATENTED SPECIALTIES.

"IRON SPONGE." Saves money, saves labor, and is the most efficient purifying agent ever offered as a substitute for lime. Now used in every State in the Union, and purifying daily over twenty-five million cubic feet. Should be used in every gas works. Its own saving will pay for it many times over.

AUTOMATIC GOVERNOR. Has been on the market but two years, and in that time has been introduced more generally than any invention ever designed for use in gas works. Over one hundred of them now in use. Sensitive; reliable; perfectly automatic; reduces leakage; satisfies consumers, and gives great relief to the Manager. No gas works is complete without one of these machines.

STEAM JET EXHAUSTER. Designed particularly for small works. Combines Exhaust Tube, Steam Governor, Gas Compensator, and Bye-Pass Valves in the most compact form possible; occupies but little space; uses very little steam; operated by ordinary workmen; saves formation of carbon in retorts; increases yield 10 to 15 per cent. Specially adapted for mixing air with oil gas. No works too small to use them profitably.

Prices given on all our specialties delivered at any point in the United States. Correspondence solicited.

CONNELLY & CO., LTD., No. 177 Broadway, New York City.

WILBRAHAM GAS EXHAUSTER AND ENGINE COMBINED.

WILBRAHAM BROS., PHILADELPHIA, PA.

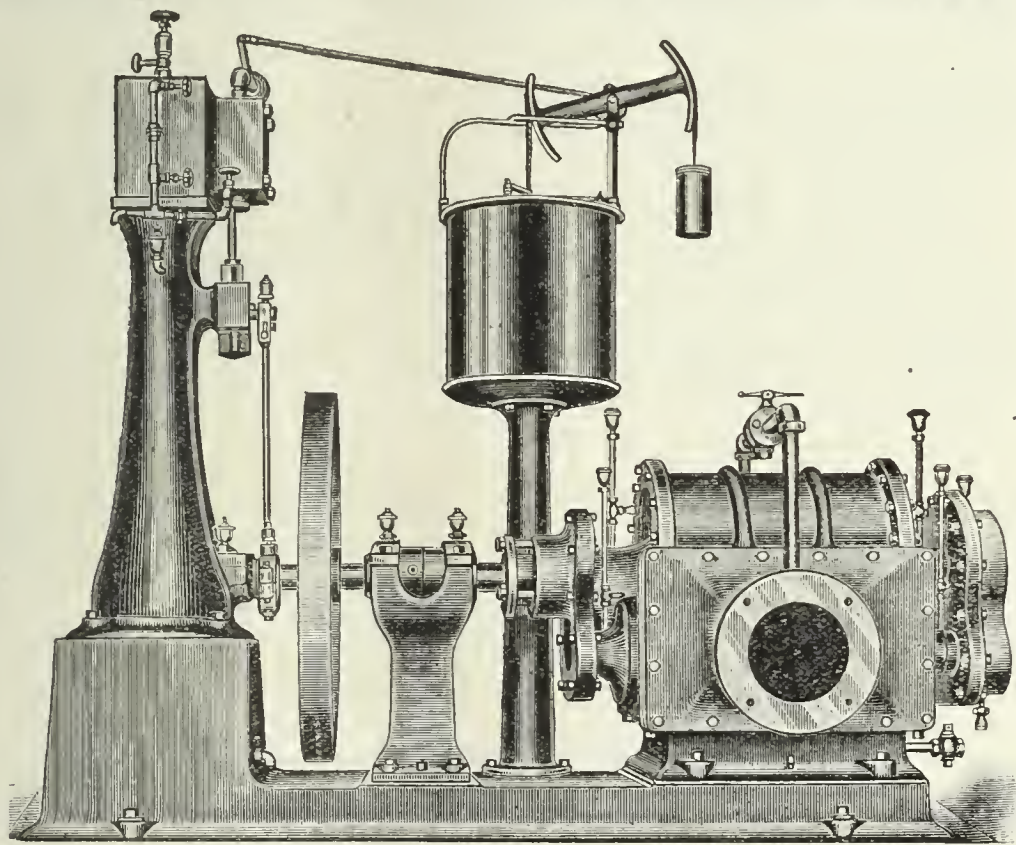

JARVIS ENGINEERING CO.,

61 Oliver St., Boston, Mass.

CONTRACTORS FOR ERECTING

COMPLETE STEAM OUTFITS FOR ELECTRIC LIGHTING STATIONS.

Steel Boilers set with Jarvis Pat. Boiler Setting

To burn **COKE SCREENINGS** for Fuel.

ARMINGTON & SIMS CO. ENGINES,

Belting direct to Dynamos, without using Shafting.

SEND FOR CIRCULARS.

REFERENCES.—Charlestown Gas & Electric Light Co., Charlestown, Mass.; Schenectady Gas & Electric Light Co., Schenectady N. Y.; Brookline Gas Co., Brookline, Mass.

Improved Patent
GAS BAG OR
BLADDER VALVE.

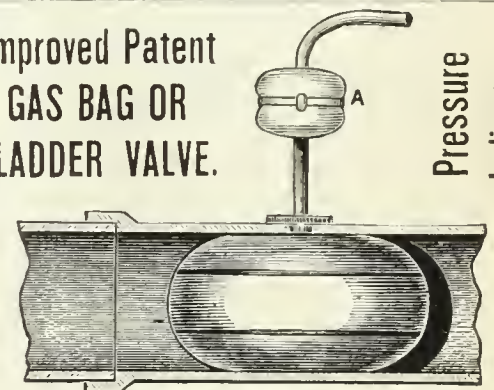

Pressure Indicator.

MANUFACTURED BY

PEERLESS MFG. CO., 34 Murray St., N.Y.

THE CLERK GAS ENGINE CO.,

Main Office, 1012, 1014, 1016, 1018 Filbert St., Philadelphia, Pa.

WM. W. GOODWIN, Prest.

E. STEIN, Sec.

S. LEWIS JONES, Asst. Sec.

A. J. DOTY, Supt.

The utility and convenience of the Gas Engine being no longer an open question, it only remains now for intending purchasers to select the BEST. We claim for the CLERK GAS ENGINE that it is equal to any other manufactured as regards steadiness in running, simplicity, and ease of keeping in repair, and that it gives the greatest amount of power for the least money (both in first cost and expense of running) of any engine made. In support of this claim we refer to the test of the Gas Engines made under the direction of the American Institute of New York, in December, 1885, and heretofore published in these columns. These engines are especially adapted for continuous running under heavy loads, and we can refer to Engines which have run 22 hours a day for months at a time.

Made in Sizes of 5, 10, 15, 20, and 25 Horse Power. All Engines Guaranteed for One Year.

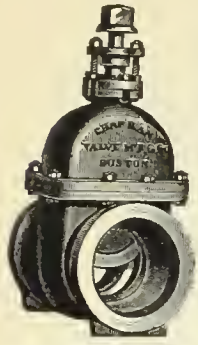

CHAPMAN VALVE MANUFACTURING CO.,

MANUFACTURERS OF

Valves and Gates for Gas, Ammonia, Water, Etc.

Also, Gate Fire Hydrants With and Without Independent Nozzle Valve. All Work Guaranteed.

WORKS & GEN'L OFFICE:
Indian Orchard, Mass.

TREASURER'S OFFICE:
72 Kilby & 112 Milk Sts, Boston, Mass.

LUDLOW VALVE MFG. CO.

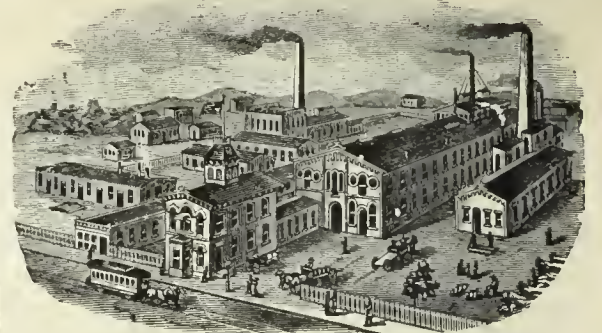

OFFICE AND WORKS,
938 to 954 River Street and 67 to 83 Vail Av
TROY, N. Y.

Hydraulic Main Dip Regulators, also
Check Valves, Foot Valves, Yard-
wash and Fire Hydrants.
Send for Circulars.

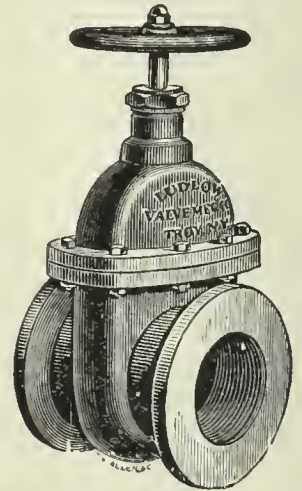

Valves.—Double and Single Gate, ½ in. to
48 in., outside and inside Screws. Indica-
tor, etc., for Gas, Water, Steam, and Oil.
Send for Circulars.

How to Reduce Leakage to Its Minimum.

USE

HOPPER'S AUTOMATIC DIFFERENTIAL GAS GOVERNOR.

Needs No Attention. Simple, Reliable, Perfectly Automatic.
"Nearly Thirty in Use."

BYE-PASSES, DRY CENTER VALVES, PRESSURE REGISTERS. Also, GOVERNORS FOR
STREET MAINS, *NOT DIFFERENTIAL*, and for EXHAUSTERS, GAS ENGINES, etc.
Our new Bye-Pass is threefold in its action—passes gas through, or bye-passes, or shuts off entirely.
Correspondence solicited; information given. Send for circulars and testimonials.

T. C. HOPPER & CO., - - No. 2227 Wood Street, Philadelphia, Pa.

G. S. COOK, Pres. THOS. DAVENPORT (late Davenport Bros.), Sec. & Treas

BARTLETT

Street Lamp Mfg. Co.

MANUFACTURERS OF

Bartlett's Patent

GLOBE LAMPS.

FOR

Streets, Parks, Railroad Stations, Public
Buildings, Etc.

LAMP POSTS A SPECIALTY

Office and Salesroom

40 & 42 College Place, N. Y. City.

Gas Companies and others intending to erect lamps and posts
will do well to communicate with us.

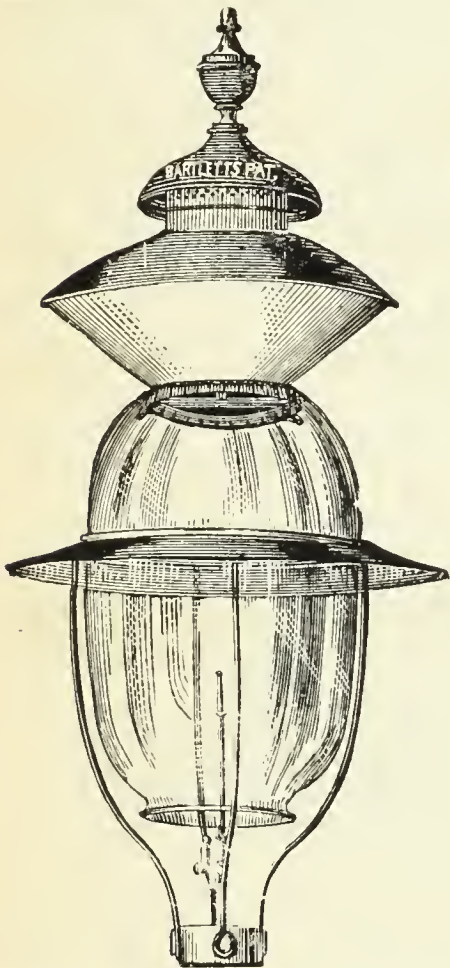

John McLean
Man'facturer of
GAS VALVES.
298 Monroe Street, N. Y.

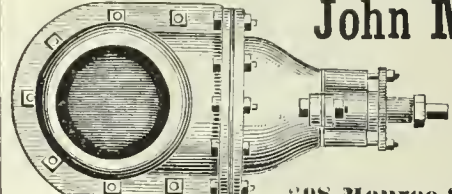

MITCHELL VANCE & CO.,
MANUFACTURERS OF
Chandeliers
and every description of
GAS FIXTURES.
Also manufacturers of Fine Gilt Bronzes and Marble Clocks,
warranted best time-keepers. Mantel Ornaments, etc.
Salesrooms, 836 Broadway, N. Y.
Special Designs furnished for Gas Fixtures for Churches, Public
Halls, Lodges, etc.

GAS AS A SOURCE OF LIGHT, HEAT, AND POWER.

By C. J. R. HUMPHREYS

A Pamphlet of twenty-nine pages, treating of the use of Gas as a
source of Light, Heat, and Power.

DESIGNED FOR DISTRIBUTION BY GAS COMPANIES AMONG THEIR CUSTOMERS AND OTHERS.

Price, 10 cents each, \$5 per 100, \$50 per 1,000.

Gas Companies can have their own imprint placed on cover without extra charge. All orders to be sent to

A. M. CALLENDER & CO.,

No. 42 Pine Street, N. Y. City.

GAS METERS.

GAS METERS.

GAS METERS.

THE AMERICAN METER CO.,

MANUFACTURERS OF

WET AND DRY GAS METERS.

Extreme Simplicity in construction! More Freedom in action! Less Friction when at work! Greater Facility for Cleaning! Perfect Accuracy in Registration!

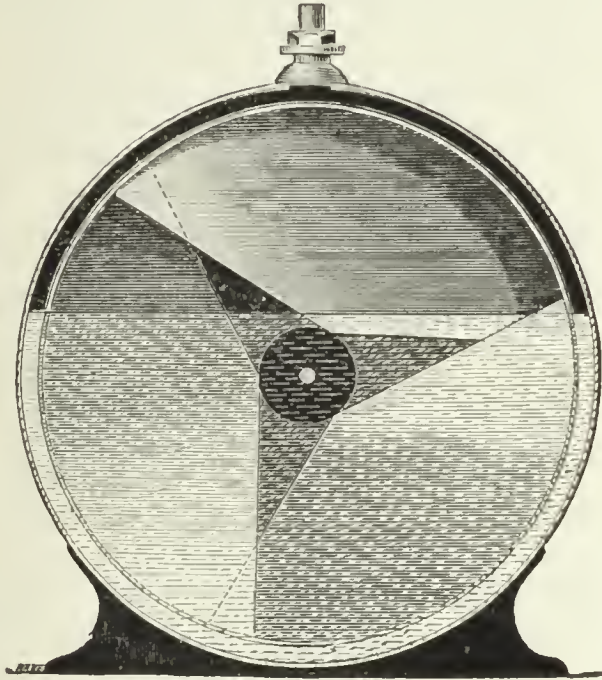

Patented May 27, 1884.

Nearly 5,000 Meters fitted with these Three-Partition Drums are in use, including Consumers' Meters, Official Standard Test Meters, and Station Meters in all sizes.

Sole Licensees in the United States for

PARKINSON'S THREE-PARTITION DRUM

For Consumers' and Station Meters.

August 22d, 1887.

Having thoroughly examined this improvement in Meter Drums, we confidently recommend their use in *Station Meters* and *Wet Meters* of smaller sizes. Among the many advantages that can be claimed for this Drum is its Increased Capacity—amounting to nearly 25 per cent. We are prepared to give estimates for new station meters or rebuilding old station meters upon this system. AMERICAN METER COMPANY.

MANUFACTORIES,

508 to 514 West Twenty-second St., N. Y.

Arch and Twenty-second St., Phila.

Nos. 244 & 246 North Wells Street, Chicago, Ill.

AGENCIES,

No. 177 Elm Street, Cincinnati, Ohio.

No. 222 Sutter Street, San Francisco Cal

No. 810 North Second Street, St. Louis, Mo.

GAS STOVE SHOW ROOMS, No. 223 Sixth Avenue, New York City.

RETORTS AND FIRE BRICK.

J. H. GAUTIER & CO.,
CORNER OF
GREENE AND ESSEX STREETS,
JERSEY CITY, N. J.

MANUFACTURERS OF

Clay Gas Retorts,
Gas House Tiles,
Fire Bricks, Etc. Etc.

Ground Clay, Fire Brick and
Fire Sand in Barrels,

J. H. GAUTIER.
C. E. GREGORY.

T. B. GAUTIER.
C. E. GAUTIER.

BROOKLYN
Clay Retort & Fire Brick Works,
(EDWARD D. WHITE & CO.)

Manufacturers of Clay Retorts, Fire Brick,
Gas House and other Tile.

VAN DYKE, ELIZABETH, RICHARDS & PARTITION STS.
Office, 88 Van Dyke St., Brooklyn, N. Y.

RETORTS AND FIRE BRICK.

LAGLEDE FIRE BRICK MFG. CO.,

MANUFACTURERS OF

Fire Brick, Gas Retorts,

AND

ST. LOUIS STANDARD SEWER PIPE.

Blast Furnace and Cupola Linings, every description of Fire
Clay Material, Fire Clay Flue Linings, Chimney Tops
Dry Milled and Crude Fire Clays, etc.

OFFICE AND DEPOT

901, 903, and 905 Pine Street,
ST. LOUIS, MO.

ESTABLISHED IN 1845.

B. KREISCHER & SONS,

OFFICE FOOT OF HOUSTON ST., E.R., N.Y.

Gas Retorts,

TILES, FIRE BRICK.

AND EVERYTHING IN THE FIRE CLAY LINE.

RETORTS AND FIRE BRICK.

MANHATTAN
FIRE BRICK & ENAMELLED CLAY
RETORT WORKS.

ADAM WEBER.

CLAY GAS RETORTS
AND RETORT SETTINGS
FIRE BRICKS, TILES, ETC.,

Office and Works, 15th Street and Avenue C., N. Y.

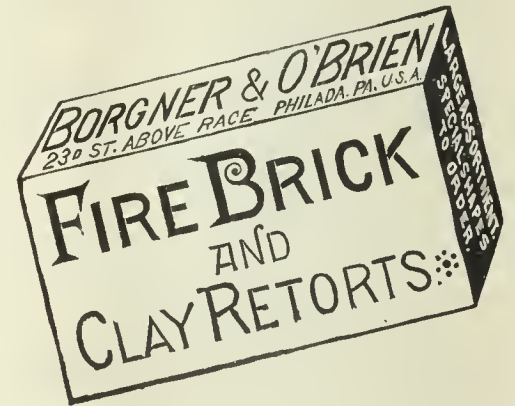

Works,
LOCKPORT STATION, PA.

—ESTABLISHED 1864.—

JAMES GARDNER, JR.,

Successor to WILLIAM GARDNER & SON.

Fire Clay Goods for Gas Works.

CHAS. H. SPRAGUE & SON, No. 70 KILBY STREET, BOSTON, MASS., Agents for the New England States.

Office, Rooms 19 & 20, Lewis Block,
PITTSBURGH, PA, P. O. Box 373.

OFFICE, 418 to 422 East 23d St., New York.

ESTABLISHED 1856.

WORKS, PERTH AMBOY, NEW JERSEY.

HENRY MAURER & SON,
Excelsior Fire Brick & Clay Retort Works
CLAY GAS RETORTS, BENCH SETTINGS, FIRE BRICK, TILES, ETC.

CHICAGO

Retort & Fire Brick Works,

OFFICE AND FACTORY,
Clark, Forty-Fifth, and La Salle Streets,
CHICAGO, ILL.

GEORGE C. HICKS, PRES. PAUL P. AUSTIN, SEC. & TREAS.

STANDARD

Clay Retorts and Settings.

BLOCKS & TILES

of every Shape and Size to Order.

Standard Fire Bricks.

OAKHILL

GAS RETORT & FIRE BRICK

Works.

Proprietors,

PARKER-RUSSELL MINING & MFG. CO.

City Office, 711 Pine Street,

ST. LOUIS, MO.

Our immense establishment is now employed almost entirely in
the manufacture of

MATERIALS FOR GAS COMPANIES.

We have studied and perfected three important points. Our re-
torts are made to stand changes of temperature, the strongest
heats of the furnace, and the abrasion of feeding and emptying.
Our customers are in almost every State of the Union, to all of
whom we refer

THOS. SMITH, Prest. AUGUST LAMBLA, Vice-Prest. & Sud

BALTIMORE

RETORT & FIRE BRICK CO.

MANUFACTORY AT

LOCUST POINT, BALTIMORE, MD.

Connection with the City by Telephone.

Clay Retorts, Blocks & Tiles,
FIRE BRICK, FIRE CLAY,
AND FIRE CEMENT.

Red and Buff Ornamental Tiles and Chim-
ney Tops. Drain and Sewer Pipe (from
2 to 30 inches). Baker Oven Tiles
12 x 12 x 2 and 10 x 10 x 2.

WALDO BROS., 88 WATER ST., BOSTON, MASS

Sole Agents the New England States.

GEROULD'S IMPROVED RETORT CEMENT.

A Cement for patching retorts, putting on mouthpieces, and
making up all bench-work joints. This Cement is mixed ready
or use. Economic and thorough in its work. Fully warranted
stick. For recommendations and price list address

C. L. GEROULD,

Manchester, N. H.

Western Agent, H. T. GEROULD, Mendota, Ill.

EVENS & HOWARD,
 916 Market St., St. Louis. Mo.
 Works, Howard Station, Mo. Pacific R.R.
Fire Brick, Gas Retorts
 AND
RETORT SETTINGS.
 Sewer Pipe, 3 to 24 in. diameter.
 Glass Pot Clay, Ground Fire Clay, in barrels and in bulk. All
 kinds of Fire Clay Goods.

Cincinnati Gas Retort & Fire Brick Works.
 —ESTABLISHED 1872.—
CHAS. TAYLOR,
 MANUFACTURER OF
Gas Retorts, Fire Brick, and Tile.
 Blast Furnace Linings, Cupola Blocks, Boiler Tiles, Grate Set-
 tings, and Stove Linings. Fire Cement, Fire Clay, Fire
 Sand, and all other Fire Clay Goods.
 Branch Works, New Cumberland, W. Va.
 GENERAL OFFICE AND WORKS,
Burns St., Cincinnati, Ohio.

EMIL LENZ,
 2 & 4 Stone St., N. Y. City.
CLAY GAS RETORTS
 (ENAMELED.)
Fire Brick, Blocks & Tiles.
 FIRE CEMENT, RETORT ENAMEL, RETORT
 CEMENT, ETC., ETC.
 Regenerative and Half-Regenerative Benches.
PORTLAND CEMENT.
 Correspondence Respectfully Solicited.

Bouton Foundry Co.,
 FOUNDERS AND MACHINISTS,
CHICAGO, ILL.
Gas Works Apparatus,
 PURIFIERS, CONDENSERS,
 Bench Work,
SPECIALS, LAMP POSTS,
SCRUBBERS,
Iron Roofs and Floors.

Plans and Estimates furnished for new works or extensions of
 old works.

PATENTS.
FRANKLIN H. HOUGH,
 Solicitor of American & Foreign Patents
 925 F. ST., WASHINGTON, D. C.

(NEAR U. S. PATENT OFFICE.)
 Personal attention given to the preparation and prosecution
 of applications for Letters Patent. All business before the U. S.
 Patent Office attended to for moderate fees. **No Agency in
 the United States possesses superior facilities
 for obtaining Patents,** or for ascertaining the patent-
 ability of inventions. Copies of patents furnished for 25 cents
 each. Correspondence solicited.



STEPHEN A. MORSE, President. M. B. DYOTT, Superintendent. EDWIN F. MORSE, Secretary.
 GODFREY REBMANN, Vice-Pres. CARLTON M. WILLIAMS, Treas.

STANDARD GAS LAMP CO.,

Office, 411 Cherry St. Factory, 1101, 1103 & 1105 Frankford Av.

Philadelphia, Pa.

It is to the interest of Gas Companies and Cities to use Dyott's Patent Champion Lamps, which
 give double the light with the same consumption of gas, and will save 50 per cent. over others in
 cost of keeping in repair. Gas Companies and others intending to erect Lamps of any description
 will do well to communicate with us. Special Drawings furnished and Estimates given on appli-
 cation upon Architects', Engineers' or our Draughtsmen's Plans.

Our Patent System of Instantaneously Lighting Gas (without electricity) for R. R. Depots is
 unequalled. Our High Candle Power Burner is superior to the Electric Light or any other High
 Candle Burner. We manufacture every description of Ornamental Lamps.

KLOENNE & BREDEL
IMPROVED REGENERATIVE FURNACES.

Self-Sealing Mouthpieces & Bridge-Pipes, Retort Houses,
WASHER-SCRUBBERS,
Gasholders, and Complete Gas Works.

Refers, by permission, to Mr. Eugene Vanderpool, of Newark, N. J.; Mr. E. G. Cowdery, of
 Milwaukee, Wis.; and Mr. Theo. Forstall, of Chicago, Ill. For further information apply to

FRED. BREDEL, 332 East 17th St., N. Y. City.

Water & Gas Pipe.

RUSTLESS Send for New Catalogue. **RUSTLESS**

The WELLS RUSTLESS IRON COMPANY,
 Nos. 7 and 9 Cliff Street, New York City.

GASHOLDER TANK CONSTRUCTION, ETC.

Gas Companies and others about to erect Gasholders will find it profitable to consult W. C. WHYTE,
 who for over thirty years has made a specialty of

Holder Tank Excavation and Mason Work.

Fifty tanks now in operation show the sort of work done. Address

W. C. WHYTE, No. 15 Cortlandt St., N. Y. City.

MILLS' REVERSIBLE LIME TRAY,

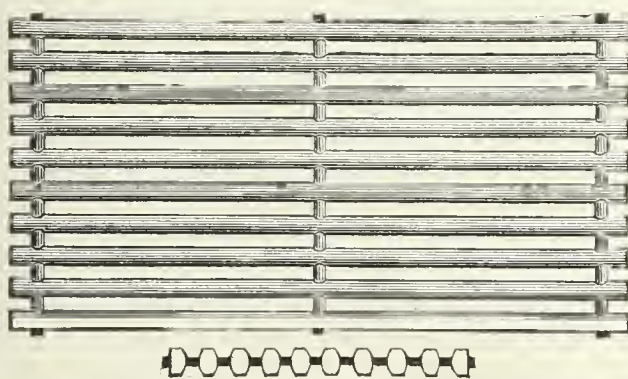

AND
WOODWORK
 Of Every Description
NEEDED BY GAS WORKS.

SEND FOR CIRCULAR AND PRICE LIST TO

GEORGE A. MILLS,
 Canton Av. & President St., Baltimore, Md.

Ferric Oxide for Gas Purification.

Ferric Oxide, as ground, screened, and prepared by me for purifying
 purposes, has now been in use for several years by many of the gas works
 throughout the country, including Detroit, Chicago, Milwaukee, East Sagi-
 naw, Burlington (Iowa), Ann Arbor, etc. It has proved, as I believe, the
Most Effective and Economical Agent now in use. I am prepared to furnish
 the Oxide by the 100 lbs. or in car load lots, and will be pleased to give
 price f.o.b. cars at Ann Arbor or at place of destination. Address

S. H. DOUGLAS, Prest. Ann Arbor (Mich.) Gas Light Co.

GAS AND WATER PIPES.

GAS AND WATER PIPES.

ENGINEERS.

SAM'L R. SHIPLEY, Pres.
HENRY B. CHEW, Treas.

JAS. P. MICHELLON, Sec.
WM. SEXTON, Supt.

P. D. WANNER, Chairman. A. H. MELLERT, Sec. & Treas.

GLOUCESTER IRON WORKS,
GLOUCESTER CITY, N. J.



Cast Iron Gas & Water Pipes, Stop Valves, Fire Hydrants, Gasholders. &c.

Office No. 6 North Seventh Street, Philadelphia.

MATTHEW ADDY, President.

W. L. DAVIS, Selling Agent.

GEO. P. WILSHIRE, Sec. & Treas.

Cincinnati and Newport Iron and Pipe Company,
NEWPORT, KY.

Lamp Posts
AND
BENCH CASTINGS

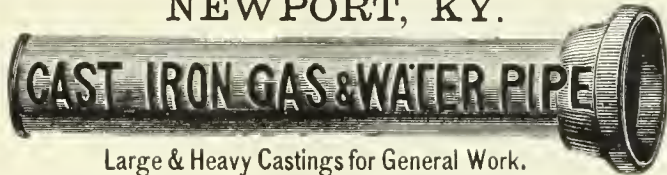

Branch
AND
SPECIAL CASTINGS

A Specialty.

Large & Heavy Castings for General Work.

FOR GAS & WATER CO'S.

Manufacture Pipe from 2 to 48 inches. All work guaranteed first quality.

Pancoast & Rogers.

WROUGHT IRON PIPE,

VALVES AND GATES,

Cast Iron Gas & Water Pipe.

28 Platt and 15 Gold St., New York.

GEO. SHEPARD PAGE,

No. 69 Wall Street, N. Y. City.

REPRESENTING

THE BOWER GAS LAMP.

C. & W. Walker's Carbonic Acid & Tar Extracting Washer

B. DONKIN & CO'S PAT. IMP. GAS VALVE.

Young & Beilby's Patents. Henry Aitkin's Patents.

R. P. SPICE, London, Eng. HENRY SIMON, Manchester, Eng.

The Management of Small Gas Works.

By **C. J. R. HUMPHREYS.** Price, \$1.

A. M. CALLENDER & CO., 42 Pine St., N. Y.

MELLERT FOUNDRY & MACHINE CO., Ltd.
Reading, Pa.



Specials—Flange Pipe, Valves and Hydrants, Lamp Posts, Retorts, etc.

General Foundry and Machine Work.

JOHN FOX, Selling Agent. 160 Broadway, N. Y.

THE OHIO PIPE COMPANY,

MANUFACTURERS OF

Cast Iron Gas & Water Pipe,

BRANCH AND SPECIAL CASTINGS.

Gas-House Bench Castings, Hydraulics, Lamp Posts, Flange Pipe and Specials, Architectural Castings, Building Columns, Joists, Cellar Grates, Sash Weights, etc.

GENERAL FOUNDERS AND MACHINISTS.

Columbus, Ohio.

M. J. DRUMMOND,



SPECIAL CASTINGS AND LAMP POSTS.

Equitable Building, 120 Broadway, N. Y.

JOS. R. THOMAS, C.E.,

May be Consulted on all Matters Relating to Gas Works and Gas Manufacture.

ADDRESS THIS OFFICE.

WM. MOONEY

(Successor to WM. FARMER)

27 Pearl Street, N. Y. City.

(One door from Whitehall Street.)

CONTRACTOR FOR THE ERECTION OF GAS WORKS, OR APPARATUS OF ANY CAPACITY. AGENT FOR

WM. FARMER'S PATENTS.

Plans and Specifications Furnished.

WM. HENRY WHITE,

CONSULTING AND CONSTRUCTING

Gas Engineer & Contractor

Estimates, Plans, and Specifications furnished for new works or extensions of existing works.

No. 32 Pine Street, New York City.

Correspondence solicited.

WM. GARDNER,

Cas Engineer,

Lewis Block, Room 20, Pittsburgh, Pa.

Those who intend to make alterations in existing gas plants, or who contemplate the erection of new works, will find it to their interest to open correspondence with the above. Plans made and estimates furnished.

GAS LAMPS.

SCRUBBERS AND CONDENSERS.

The Siemens and Lungren REGENERATIVE GAS LAMPS.

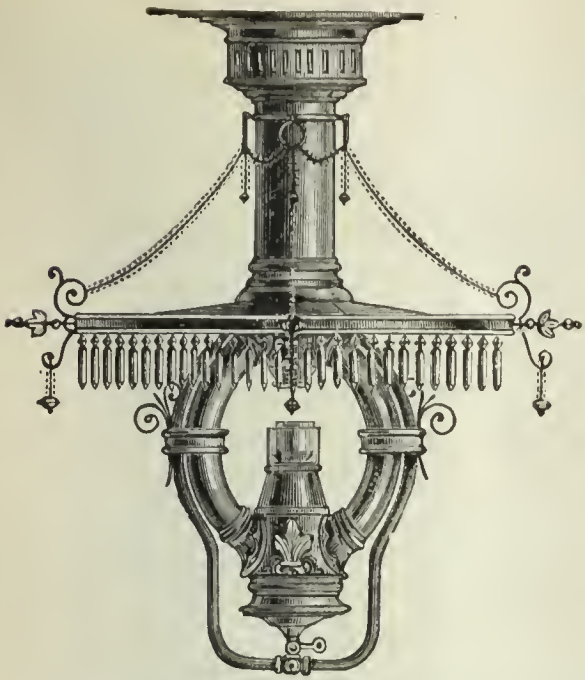

SIEMENS LAMP.

A System of Burning Gas whereby its Illuminating Power is Increased from 300 to 400 per ct. without the Expense, Trouble and Annoyance resulting from the use of Hydrocarbon Enriching Material.

The Siemens-Lungren Company received the only Silver Medal or Highest Award for Gas Burners at the "Novelties" Exhibition of the Franklin Institute, held at Phila., Oct., '85.

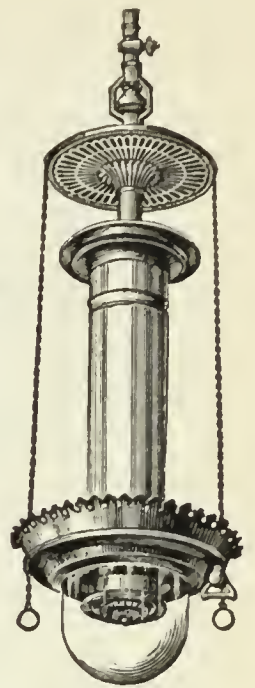

LUNGREN LAMP.

THIRTEEN CANDLE POWER PER CUBIC FOOT OF GAS!

This result is obtained

SIMPLY BY THE SCIENTIFIC APPLICATION OF THE REGENERATIVE PRINCIPLE.

Consequently this largely increased illumination is always maintained without further cost and frequent attention.

THE SIEMENS-LUNGREN COMPANY,

N. E. Cor. 21st. St. and Washington Av., Phila., Pa.

KIRKHAM, HULETT & CHANDLER, Limited,
London, S. W., England.

325 PATENT "STANDARD" WASHER-SCRUBBERS,

Equal to a Daily Capacity of

288,492,500 Cu. Ft. of Gas,

Have been Supplied Throughout the World, and are

GIVING UNIVERSAL SATISFACTION!

During the present year the following Companies in the United States have ordered "Standard" Washer-Scrubbers:

Hartford, Conn.

Laclede (St. Louis, Mo.)

Lincoln, Neb.

Brooklyn, N. Y. (2)

Denver, Col.

Nassau (Brooklyn, N. Y.).

Altoona, Pa.

Lawrence, Mass.

Lynn, Mass.

GEO. SHEPARD PAGE, 69 WALL STREET, NEW YORK,

Agent for the Western Hemisphere.

GAS WORKS APPARATUS AND CONSTRUCTION.

GAS WORKS APPARATUS AND CONSTRUCTION.

WORKS: { MILLVILLE, N. J.
FLORENCE, "
CAMDEN, "

R. D. WOOD & CO.,

OFFICES: { 400 CHESTNUT ST.,
PHILADELPHIA.

CAST-IRON PIPE 1½ to 72 Inches in Diameter.

Water Machinery and Gas Apparatus.

HEAVY CASTINGS.

HOLDERS,

PURIFIERS,

FLOORS AND ROOFS,

LAMP POSTS,

CONDENSERS,

FLANGED PIPE,

VALVES,

BENCH WORK,

FIRE HYDRANTS,

METER CASES.

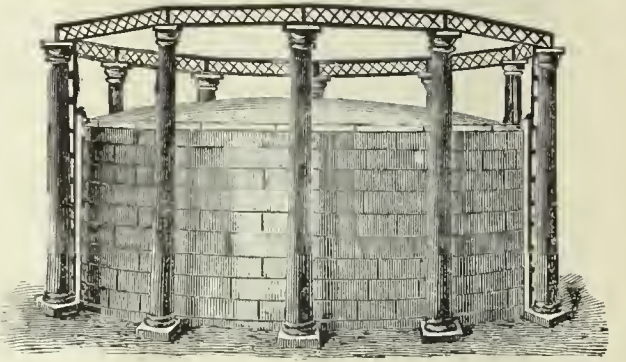
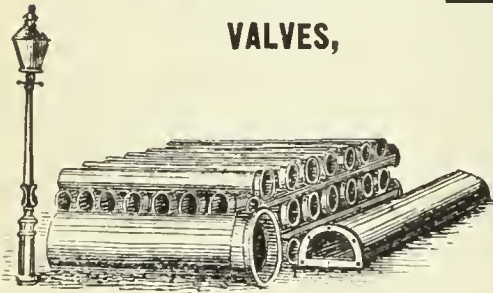

Estimates and Specifications for
NEW WORKS or **EXTENSIONS**
or **ALTERATIONS** of **OLD ONES.**

SOUTHWARK FOUNDRY AND MACHINE COMPANY,

Successors to MERRICK & SONS,

GAS APPARATUS,

Holdings, Purifiers, Washers, Etc., Etc. Boiler and Tank Work. Steam Engines.
Hydraulic Machinery. Bessemer Plants, Etc.

Washington Ave. and Fifth Street, Philadelphia, Pa.

MORRIS, TASKER & CO.,

Limited,

Builders of Gas Works,

PHILADELPHIA PA.

GASHOLDERS, PURIFIERS, SCRUBBERS, CONDENSERS, EXHAUSTERS,

Bench Castings, Iron Roofs, Lamp Posts,

VALVES, STREET MAIN SPECIALS, ETC.,

MANUFACTURED BY

KERR MURRAY MANUFACTURING COMPANY.

From 1880 to 1886, inclusive, we erected Gasholders for the following cities, viz.:

Adrian, Mich.	East End Gas Co., Pitts-	Janesville, Wis.	New Cas le, Pa.	Valparaiso, Ind.
Akron, Ohio.	burgh, Pa.	Johnstown, Pa.	Niagara Falls, N. Y.	Van Wert, Ohio.
Albuquerque, N. M.	East Saginaw, Mich.	Key West, Fla.	Osawatomie, Kans.	Wabash, Ind.
Altoona, Pa.	Elgin, Ills.	La Crosse, Wis.	Pittsburgh, Pa. (2)	Waco, Texas.
Anderson, Ind.	Evanston, Ills.	Lebanon, Ind.	Plainfield, Ind.	Waukesha, Wis.
Bellaire, Ohio.	Eufaula, Ala.	Lima, Ohio.	Portage City, Wis.	Wheeling, West Va.
Birmingham, Ala.	Frankfort, Ind.	Logan, Ohio.	Sedalia, Mo.	Wellington, Kans.
Bucyrus, Ohio.	Freeport, Ills.	Louisville, Ky.	Sheboygan, Wis.	West Pittsburgh, Pa.
Canton, Ohio.	Galesburg, Ills.	Mankato, Minn.	South Bend, Ind.	Xenia, Ohio.
Cireleville, Ohio.	Grafton, West Va.	Mansfield, Ohio.	South Chicago, Ills.	Youngstown, Ohio.
Colorado Springs, Col.	Greensburg, Pa.	Marshalltown, Iowa.	Springfield, Ills.	Ypsilanti, Mich.
Danbury, Conn.	Huntington, Ind. (2)	Meridian, Miss.	Streator, Ills.	
Delaware, Ohio.	Ironton, Ohio.	Minneapolis, Minn.	Topeka, Kans.	
Delphos, Ohio.	Jamestown, N. Y.	Muskegon, Mich.	Uniontown, Pa.	

Under construction, 1887.

Akansas City, Kans.	Grand Forks, Dakota.	Mobile, Ala.	Santa Fe, N. M.	Fuel Gas and Electric Engi-
Dallas, Texas.	Grand Rapids, Mich.	Pittsburgh, Pa.	Wichita, Kans.	neering Co., Pittsburgh, Pa.
El Paso, Texas.	La Crosse, Wis.	Pine Bluff, Ark.	Lexington, Mo.	Stillwater, Minn.

Estimates, with Plans and Specifications, for new or the rebuilding of old works, furnished on application.
Correspondence solicited. Address

KERR MURRAY MANUFACTURING CO.,

A. D. CRESSLER, General Manager.

FORT WAYNE, IND.

GAS WORKS APPARATUS AND CONSTRUCTION.

GAS WORKS APPARATUS AND CONSTRUCTION.

JAMES R. FLOYD,

(SUCCESSOR TO HERRING & FLOYD)

Oregon Iron Works,

531 to 543 West 20th St., N. Y.

Practical Builders of Gas Works,

MANUFACTURERS OF

ALL KINDS OF CASTINGS

AND

APPARATUS FOR GAS-WORKS.

BENCH CASTINGS

from benches of one to six Retorts each.

WASHERS: MULTITUBULAR AND AIR CONDENSERS; CONDENSERS; SCRUBBERS

(wet and dry), and

EXHAUSTERS

for relieving Retorts from pressure.

BENDS and BRANCHES

all sizes and description.

FLOYD'S PATENT

MALLEABLE RETORT LID.

PATENT

SELF-SEALING RETORT LIDS.

FARMER'S

PATENT BYE-PASS DIP-PIPE.

SABBATON'S PATENT

FURNACE DOOR AND FRAME.

BUTLER'S

COKE SCREENING SHOVELS.

GAS GOVERNORS,

and everything connected with well regulated Gas Works at low price, and in complete order.

SELLER'S CEMENT

for stopping leaks in Retorts.

N. B.—**STOP VALVES** from three to thirty inches—a very low price.

Plans, Specifications, and Estimates furnished.

GAS vs. ELECTRIC LIGHT.

We would invite attention to the able and exhaustive argument of General A. Hickenlooper, President of the Cincinnati Gas Light and Coke Company, contained in a handsome pamphlet of 96 pages, entitled

"EDISON'S INCANDESCENT ELECTRIC LIGHTS FOR STREET ILLUMINATION. REPORT OF AN ARGUMENT DELIVERED BY A. HICKENLOOPER BEFORE THE COMMITTEE ON LIGHT, MUNICIPAL COUNCIL, CITY OF CINCINNATI, JULY 22, 1886."

This is a subject of special interest to all Gas Light Companies.

Prices.

25 copies..... \$7.50 100 copies..... \$22.50
50 copies..... 12.50 250 copies..... 50.00

A sample copy will be sent by mail on receipt of 50 cts.

A. M. CALLENDER, & CO., 42 PINE ST., N. Y. CITY.

THE CONTINENTAL IRON WORKS.

THOS. F. ROWLAND, Prest. WARREN E. HILL and CHAS. H. CORBETT, V.-Presds. THOS. F. ROWLAND, JR., Sec. & Treas.

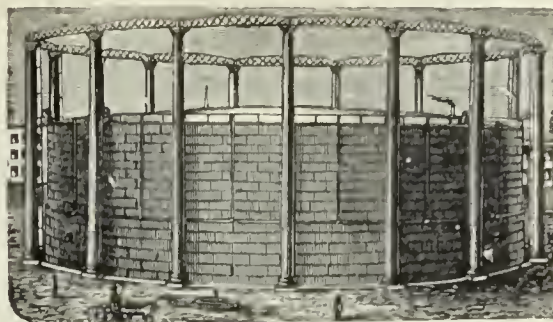

GAS HOLDERS OF ANY MAGNITUDE.

P. O. Station G., BROOKLYN, N. Y.

ENGINEERS AND MANUFACTURERS OF

Gas Holders

CONDENSERS, SCRUBBERS, VALVES,

PURIFIERS, SELF-SEALING RETORT LIDS,

Hydraulic Mains,

And all other articles connected with the manufacture and distribution of Gas.

H. RANSIAW, Prest. & Mangr. WM. STACEY, Vice-Prest. T. H. BIRCH, Asst. Mangr. R. J. TARVIN, Sec. & Treas.

STACEY MFG. CO.,

MANUFACTURERS OF

Single and Telescopic Gasholders,

IRON ROOFS, BRIDGES, LAMP POSTS,

Water and Oil Tanks, Coal Elevator Cars,

COKE CRUSHERS, BENCH CASTINGS,

And all kinds of Wrought and Cast Iron Work used in the erection of Coal and Oil Gas Works. Rolling Mill Machinery and Heavy Castings a Specialty.

Foundry:

33, 35, 37 & 39 Mill Street.

Wrought Iron Works:

16, 18, 20, 22, 24 & 26 Ramsey Street.

Cincinnati, Ohio.

1842. **DEILY & FOWLER,** 1887.

Laurel Iron Works.

Address, No. 39 Laurel Street, Philadelphia, Pa.

MANUFACTURERS OF

GASHOLDERS,

Single or Telescopic, with Cast or Wrought Iron Guide Frames.

HOLDERS BUILT SINCE 1881:

- | | | | | |
|-----------------------|---------------------------|---------------------------|----------------------------|----------------------------|
| Seranton, Pa. (2d) | Hollidaysburg, Pa. | Jackson, Mich. | Montgomery, Ala. | New Castle, Pa. |
| West Point, N. Y. | Galveston, Texas (2d.) | Kalamazoo, Mich. (3d.) | Newport, R. I. | Long Island City, N. Y. |
| Fitchburgh, Mass. | Marlboro, Mass. | Glen Island, N. Y. | Portland, Oregon. | Macon, Ga. |
| New London, Conn. | Denver, Col. | Warren, Ohio. | Allegheny, Pa. (2d.) | York, Pa. |
| Derby, Conn. | Chicago, Ill. (West Side) | Bath, N. Y. | Atlanta, Ga. (2d.) | Chester, Pa. |
| Bridgeport, Conn. | Pittsburgh, Pa. (S. Side) | Lynn, Mass. | N.Y. City (Central Gas Co) | Hazleton, Pa. (2d.) |
| Allegheny, Pa. (1st.) | Pawtucket, R. I. | New Bedford, Mass. | Lynchburg, Va. (2d.) | Novelties Exhib., Phila |
| St. Hyacinth, Can. | Brookline, Mass. | Waterbury, Conn. | Saylesville, R. I. | State Island, N. Y. |
| Norwalk, O. | Sherbrooke, Can. | Deseronto, Can. | Rondout, N. Y. | Sangerties, N. Y. |
| Brattleboro, V. | Burlington, N. J. (2d.) | Hoosic Falls, N. Y. (2d.) | Atlantic City, N. J. | Clinton, Mass. (Lan. Mills |
| Waltham, Mass. (2d.) | Bridgeton, N. J. | Bethlehem, Pa. | Augusta, Ga. | Chattanooga, Tenn. |
| West Chester, Pa. | Bay City, Mich. | Atlanta, Ga. (1st.) | Waltham, Mass. (2d.) | Galveston, Texas. (3d.) |
| Baltimore, Md. | Erie, Pa. | Savannah, Ga. | Mahanov City, Pa. | Omaha, Neb. |

SMITH & SAYRE MFG. COMPANY,

G. PORTER, Prest.

245 Broadway, N. Y.

CHAS. W. ISBELL, Sec'y.

Machinery & Apparatus for Gas Works

Drawings, Plans, and Estimates Furnished for the Improvement, Extension, or Alteration of Gas Works, or for the Construction of New Works.

Mackenzie's Patent Rotary and Steam Jet Gas Exhausters, Governors, Compensators, Condensers, Washers, Scrubbers. Isbell's Patent Automatic Street Pressure Governor Gas and Water Valves, Hydraulic Main Dip Regulator, Bench Castings, etc. Purifying Boxes and "Standard" Scrubbers. Isbell's Patent Self-Sealing Retort Doors.

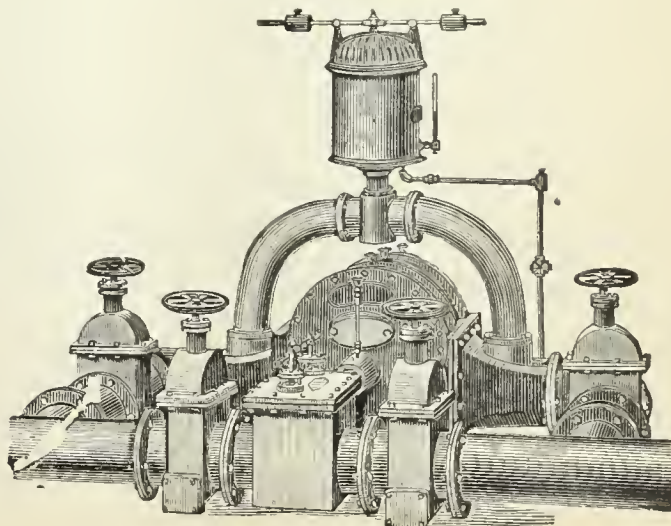

GAS COALS.

CANNEL COALS.

GAS ENRICHERS.

JAMES D. PERKINS.

PERKINS & CO.,

F. SEAVERNS.

General Sales Agents for

The Youghioghenny River Coal Company's**OCEAN MINE YOUGHIOGHENY GAS COAL.**

The Coal from the Ocean Mine (recently operated by *Messrs. W. L. Scott & Co.*, of Erie, Pa.,) is now used by all the leading Gas Companies in the United States from Maine to Texas, and is recognized as *the only reliable Youghioghenny Gas Coal.* (See Map on p. 87 of this Journal, Feb. 16, '85.)

P. O. Box 3695,
New York.**PERKINS & CO., 228 and 229 N. Y. Produce Exchange.**BEAVER STREET
ENTRANCE.**BRECKENRIDGE CANNEL,
OF KENTUCKY.**

This Colliery was re-opened in June, 1886, since which date the Cannel has been delivered to over sixty of the leading Gas Companies in this country and in Europe. As an enricher ONE TON of this Cannel will do the work of TWO TONS of any other available Cannel, and is more economical than Naptha or Oil of any character. It can be delivered in parcels of one car load or more to any point in the United States or Canada.

(See AMERICAN GAS LIGHT JOURNAL, June 16, '86, pp. 346-7.)

P. O. Box 3695,
New York.**PERKINS & CO., 228 and 229 N. Y. Produce Exchange**BEAVER STREET
ENTRANCE.**JAMES & WILLIAM WOOD,
Gas and Cannel Coal Contractors,**

No. 40 St. Enoch Sq., Glasgow. No. 2 Talbot Court, London.

Proprietors of the **BATHVILLE COLLIERIES** (which produce the celebrated **BOGHEAD CANNEL**), Shields, Shieldmuir, Drumpeller, and other Collieries. This Firm offer

STANDARD CANNELS,**Unequaled as Gas Enrichers.**

Analyses, prices, and all further information furnished on application to

Agency for U. S., Room 93, Nos. 2 & 4 Stone St., N. Y. City.**The Standard Oil Company,**

REFINERS OF

NAPTHA AND GASOLINES.

ALSO MANUFACTURERS OF

**A Special Grade of Naptha for
Gas Companies****FOR ENRICHING COAL GAS.**

Correspondence solicited.

No. 43 Euclid Avenue, Cleveland, Ohio.

To Gas Companies.We make to order **CAP BURNERS** to burn any amount under a stated pressure. Send for samples.Also, **SERVICE CLEANERS, DRIP PUMPS, and STREET MAIN PROVING APPARATUS.****C. A. GEFROER,**

248 N. 8th Street, Phila., Pa.

**GOODWIN'S DIRECTORY
OF THE GAS LIGHT COMPANIES of the UNITED STATES & CANADA.****Price, \$10.00.**

Orders may be sent to

A. M. CALLENDER & CO., No. 42 Pine Street, N. Y. City.

COKE CRUSHERS.

GAS COALS.

GAS COALS.

Newburgh Orrel Coal and Coke Co.

MINERS AND SHIPPERS OF

Mountain Brook Steam and Smithing Coals,

**NEWBURGH, PALATINE,
AURORA & TYRCONNELL
GAS COALS.**

Foundry & Crushed Coke Shipped Direct from Ovens
Mines Situated at
Newburgh, Flemington & Fairmont, W. Va.

HOME OFFICE,

33 S. Gay St., Baltimore.

CHAS. MACKALL, Gen. Mangr.

CHAS. W. HAYS, Agent in New York,

Room 147, WASHINGTON BUILDING, No. 1 Broadway.

Shipping wharves at Locust Point, Baltimore.

THE DESPARD COAL COMPANY

OFFER THEIR SUPERIOR

DESPARD COAL

To Gas Light Companies and Manufacturers of Fire Clay Goods
Throughout the Country.

ROUSSEL & HICKS, } AGENTS. { BANGS & HORTON,
71 Broadway, N. Y. } 16 Kilby St., Boston.

Mines in Harrison Co., West Va. Wharves, Locust Point, Balt.

Company's Office, 15 German St., Baltimore, Md.

Among the consumers of Despard Coal we name: Manhattan
Gas Light Co., N. Y.; Metropolitan Gas Light Co., N. Y.; Jersey
City, (N. J.) Gas Light Co.; Washington (D. C.) Gas Light Co.;
Portland (Maine) Gas Light Co. Reference to them is requested.

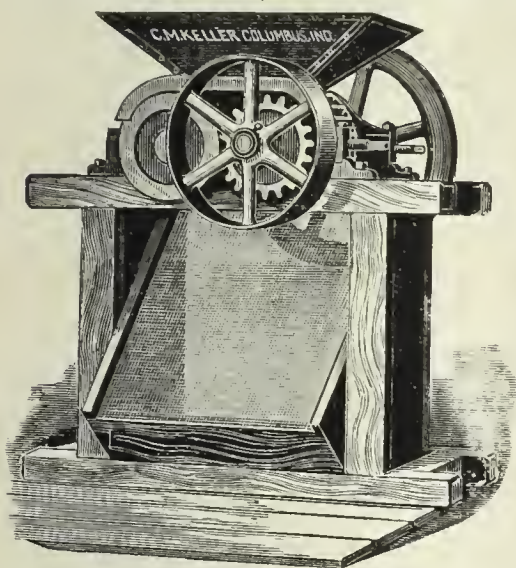

Keller's Adjustable Coke Crusher.

SIMPLE, STRONG, AND DURABLE.

C. M. Keller, Sec. & Supt. Gas Lt. & Coke Co. Columbus, Ind.

Correspondence Solicited.

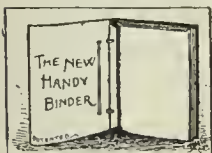

**THE NEW
HANDY BINDER.**

This article may be described as elegant
in appearance, strong, durable, and possessing many special
qualities of its own. It allows the opening of the pages per-
fectly flat, whether one or several numbers are in the binder.
Any number can be taken out and replaced without disturbing
the others. The papers are not mutilated for subsequent bind-
ing in permanent form. The binder is supplied with gilt side
title, and is an ornament to any desk or reading table. The
JOURNAL, filed in the Handy Binder, becomes a volume of great
value, always convenient for instant reference. Handy Binder,
Postage paid, \$1 00.
A. M. CALLENDER & CO., 42 Pine St., N. Y.

**THE
PENN GAS COAL CO.**

OFFER THEIR

Coal, Carefully Screened & Prepared for Gas Purposes.

Their Property is located in the Youghiogeny Coal Basin, near Irwin and Penn Stations on the
Pennsylvania Railroad, and on the Youghiogeny River.

Principal Office:

209 SOUTH THIRD STREET, PHILA., PA.

Points of Shipment:

Pennsylvania Railroad Piers; Greenwich Wharves, Delaware
River; Pier No. 1 (Lower Side), South Amboy, N. J.

Chesapeake & Ohio Railway Coal Agency,

FOR THE SALE OF THE

**Superior Kanawha Gas Coals, Cannelton Cannel,
Also, SPLINT AND STEAM COALS,**

From the Kanawha and New River Regions, on the line of the Chesapeake & Ohio R'way.

C. B. ORCUTT, Sales Agent. | OFFICE, 150 BROADWAY, N. Y.

FRANCIS H. JACKSON, Prest. EDMUND H. McCULLOUGH, V.-Prest. CHAS. F. GODSHALL, Treas. H. C. ADAMS,

THE WESTMORELAND COAL CO.

Chartered 1854.

Mines situated on the Pennsylvania and the Baltimore
and Ohio Railroads, in Westmoreland County, Penn.

POINTS OF SHIPMENT:

PHILADELPHIA, BALTIMORE, SOUTH AMBOY, N. J.,
WATKINS (SENECA LAKE), N. Y.

Since the commencement of operations by this Company its well-known
Coal has been largely used by the Gas Companies of New England and the
Middle States, and its character is established as having no superior in gas
giving qualities, and in freedom from sulphur and other impurities.

Principal Office, 224 South 3d St., Phila., Pa.

A. M. SCOTT, PRESIDENT. A. DEMPSTER, C.E., SECRETARY. W. K. GILLESPIE, TREASURER.

MONONGAHELA AND PETERS CREEK GAS COAL CO.,

PRODUCERS OF

Coal Bluff Gas Coal.

MINES LOCATED ON THE MONONGAHELA DIVISION OF THE PENNSYLVANIA RR.,
IN THE CENTRAL PORTION OF THE PITTSBURGH COAL FIELD.

Points of Shipment—Buffalo, Cleveland, Erie, Chicago, New Orleans.

Since the introduction of Coal Bluff Gas Coal it has taken rank among the few first-class Gas Coals, and ac-
knowledges no superior in gas-giving qualities, ease of working, quality of coke, and freedom from impurities.

Milwaukee Agents, F. R. BUELL & CO., - - - Milwaukee, Wis.

General Office, 43 Sixth Ave., Pittsburgh, Pa.

GAS METERS.

GAS METERS.

GAS METERS.



INTERNATIONAL--1876--EXHIBITION.

The U. S. Centennial Commission

HAVE DECREED AN AWARD TO

HARRIS, GRIFFIN & CO.,

Twelfth and Brown Streets, Philadelphia, Pa. No. 49 Dey Street, N. Y. City, and No. 75 North Clinton Street, Chicago, Ill.

FOR THE FOLLOWING REASONS:

The Exhibit consists of a Series of METERS from the Largest Size Station Meters for the use of the MANUFACTURE OF GAS, to those for the use of the ORDINARY CONSUMER. The Instruments are WELL MADE, RELIABLE as to INDICATION, and embody a number of sundry improvements which, with the general character of the Exhibit, entitle the whole to commendation.

Attest—J. L. CAMPBELL,
Secretary, pro-tem.

Signed—A. T. GOSHORN,
Director General

J. R. HAWLEY,
President

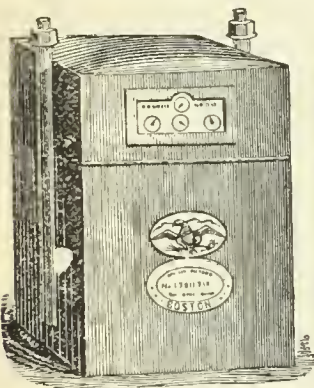

Dry Gas Meter.

With 39 years' experience and the best facilities for manufacturing, is enabled to furnish reliable work and answer orders promptly.

NATHANIEL TUFTS,*No. 153 Franklin Street, Boston, Mass.,*

MANUFACTURER OF

DRY GAS METERS.

Station Meters of any Capacity.

Test and Experimental Meters, Pressure Registers, Pressure Gauges, Pressure and Vacuum Gauges.

METER PROVERS, PHOTOMETERS, STREET LANTERNS, ETC., ETC.

Patent Cluster Lanterns for Street Illumination.

SCIENTIFIC BOOKS.

We are prepared to furnish to Gas Managers, and others interested in the topics treated of, the following books, at prices named:

KING'S TREATISE ON THE MANUFACTURE OF COAL GAS. Three vols.; \$10 per vol.	PRACTICAL TREATISE ON HEAT, by THOMAS BOX. Second edition. \$5.	THE GAS MANAGER IN THE LABORATORY, by a Practica Student. 8vo., Cloth. \$1.50.
GAS MANUFACTURE, by WILLIAM RICHARDS. 4to., with numerous Engravings and Plates, in Cloth binding. \$12.	GAS WORKS—THEIR ARRANGEMENT, CONSTRUCTION, PLANT, AND MACHINERY. \$8.	THE DOMESTIC USES OF COAL GAS, AS APPLIED TO LIGHTING, by W. SUGG. \$1.40.
THE GAS ANALYST'S MANUAL, by F. W. HARTLEY. \$2.50.	COAL; ITS HISTORY AND USE, by PROF. THORPE. \$3.50.	DISTILLATION OF COAL TAR AND AMMONIACAL LIQUOR by GEO. LUNGE. \$8.50.
TECHNICAL GAS ANALYSIS. \$2.80.	THE GAS WORKS OF LONDON, by COLBURN. 60 cents.	A TREATISE ON THE COMPARATIVE COMMERCIAL VALUES OF GAS COALS AND CANNELS, by D. A. GRAHAM 8vo., Cloth. \$3.
GAS MANAGER'S HANDBOOK, by THOS. NEWBIGGING. \$4.80.	THE GAS FITTER'S GUIDE, Showing the Principles and Practice of Lighting with Coal Gas, by JOHN ELDREDGE. 40 cents.	GAS AS A SOURCE OF LIGHT, HEAT, AND POWER, by C. J. R. HUMPHREYS. 10 cents.
GAS CONSUMER'S GUIDE. \$1.	GAS WORKS, AND MANUFACTURING COAL GAS, HUGHES. \$2.20.	GAS COMPANIES DIRECTORY. \$10.
A GUIDE TO GAS LIGHTING. 40 cents.	THE MANAGEMENT OF SMALL GAS WORKS, by C. J. R. HUMPHREYS. \$1.	GAS VERSUS ELECTRIC LIGHT. 50 cents.
GAS MEASUREMENT AND GAS METER TESTING, by F. W. HARTLEY. \$1.60	MANUAL FOR GAS ENGINEERING STUDENTS, by D. LEE, 40 cents.	PURIFICATION OF COAL GAS, by R. P. SPICE. 8vo. \$3.
GAS CONSUMER'S HANDBOOK, by WILLIAM RICHARDS, C.E.; 18mo., Sewed. 20 cents.	HOW TO MANAGE GAS, by F. WILKINS. Paper. 20 cents.	
A PRACTICAL TREATISE ON GAS AND VENTILATION with Special Relation to Illuminating, Heating, and Cooking by Gas, by E. E. PERKINS. \$1.25.		

The above will be forwarded by express, upon receipt of price. We take especial pains in securing and forwarding any other Works that may be desired, upon receipt of order. All remittances should be made by check, draft, or post office money order.

A. M. CALLENDER & CO., No. 42 Pine Street, New York.**KING'S TREATISE ON COAL GAS.**

The most complete work on Coal Gas ever published. Three vols., bound \$30.

A. M. CALLENDER & CO., No. 42 Pine Street, New York.

GAS METERS.

GAS METERS.

GAS METERS.

GEO. J. McGOURKEY, Pres. WM. H. McFADDEN, Vice-Pres. (Phila.) WM. N. MILSTED, Gen. Supt. & Treas. (New York). WM. H. DOWN Sec.

AMERICAN METER COMPANY,

WET AND DRY GAS METERS. STATION METERS. EXHAUSTER GOVERNORS. DRY CENTRE VALVES. GOVERNORS FOR GAS WORKS.

PRESSURE REGISTERS. PRESSURE & VACUUM REGISTERS. PRESSURE & VACUUM GAUGES. CRESSON GAS REGULATORS. MARSLAND WATER METERS.

METER PROVERS. PORTABLE TEST METERS. EXPERIMENTAL METERS. AMMONIA TEST METERS. BAR AND JET PHOTOMETERS.

<p>Manufactories: 512 W. 22d St., N. Y. Arch & 22d Sts., Phila.</p>	<p>GAS STOVES, SUGG'S "STANDARD" ARGAND BURNERS, SUGG'S ILLUMINATING POWER METER, Wet Meters, with Lizar's "Invariable Measuring" Drum.</p>	<p>Agencies: 177 Elm Street, Cincinnati. 214 & 216 N. Wells Street, Chicago. 810 North Second Street, St. Louis. 222 Sutter St., San Francisco.</p>
--	--	--

HELME & McILHENNY,

(Successors to Harris & Brother. Established 1848.)

GAS METER MANUFACTURERS,

CONTINUE AS HERETOFORE AT THE OLD ESTABLISHMENT,

Nos. 1339 to 1349 Cherry Street, Philadelphia, Pa.,

To Manufacture Wet and Dry Gas Meters, Station Meters, Experimental Meters, Meter Provers, Center Seals, Pressure Registers
GOVERNORS, INDICATORS, PHOTOMETERS, & ALL OTHER KINDS OF APPARATUS FOR USE IN GAS WORKS.

From our long practical experience of the business, and from our personal supervision of all work, we can guarantee all orders to be executed promptly and in every respect satisfactorily.

WM. WALLACE GOODWIN, Pres. and Treas. WM. H. MERRICK, V.-Pres. S. L. JONES, Sec. S. V. MERRICK, Supt.

THE GOODWIN GAS STOVE AND METER COMPANY,

Successors to W. W. GOODWIN & CO.

1012, 1014 and 1016 Filbert St., Phila., Pa. 142 Chambers St., New York.
76 Dearborn St., Chicago, Ill.

WALDO BROS., Agents, 88 Water St., Boston.

MANUFACTURERS OF THE "SUN DIAL" GAS STOVES, FOR COOKING AND HEATING PURPOSES.

Dry and Wet GAS METERS, Station Meters (Square, Cylindrical or in Staves) Glazed Meters, King's and Sugg's Experimental Meter Post Meters, Etc., Etc., Meter Provers (sizes 2, 5 and 10 feet), Pressure Gauges of all kinds, Pressure Registers, Pressure and Vacuum Registers, Pressure Indicators (sizes 4 inch, 6 inch and 9 inch), King's Pressure and Vacuum Gauges, Dry and Wet Centre Seals, Dry and Wet Governors, Exhauster Governors, Photometers of all descriptions. Letheby's Sulphur and Ammonia Test Apparatus complete—also Testing and Chemical Apparatus of all kinds, and of the most perfect description, for all purposes relating to Gas.

GOODWIN'S IMPROVED LOWE'S JET PHOTOMETER.

Agents for Bray's Patent Gas Burners and Lanterns.

Special attention to repairs of Meters, and all apparatus connected with the business.
All work guaranteed first class in every particular, and orders filled promptly.

G. B. EDWARDS, Mang'r, New York.
E. H. B. TWINING, Mang'r, Chicago.
Represented by S. S. STRATTON.

D. McDONALD & CO.,

GAS METER MANUFACTURERS.

(Established 1854.)

51 Lancaster St., Albany, N. Y. 34 & 36 West Monroe St., Chicago, Ill.

STATION METERS, EXPERIMENTAL METERS, METER PROVING, PRESSURE & VACUUM REGISTERS, PRESSURE GAUGES, ETC.

Also STAR GAS STOVES, RANGES, and HEATING STOVES.

We use only the very best materials, and employ the most skilled labor, and by our long experience (32 years) and personal supervision of every detail, we feel justified in assuring the public that our goods will give perfect satisfaction. Every Meter emanating from our establishment will bear the State Inspector's BADGE, and will be fully warranted by us. Our Annual and Calendar will be sent to Gas Companies upon application.

GAS STOVES.

GAS STOVES.

GAS STOVES.

THE GOODWIN GAS STOVE AND METER CO.,

1012-18 Filbert St., Phila., 142 Chambers St., N. Y., 76 Dearborn St., Chicago.

Agents, WALDO BROTHERS, 88 Water Street, Boston.

WM. W. GOODWIN, PRES. & TREAS.
W. H. MERRICK, VICE-PRES.
S. LEWIS JONES, SEC.
SAMUEL V. MERRICK, SUPT.

SOLE MANUFACTURERS OF THE

G. B. EDWARDS, Mang'r, N. Y.
E. H. B. TWINING, Mang'r, Chicago.
Represented by S. S. STRATTON.

"SUN DIAL" GAS STOVES

The Most Economical, Efficient, and Durable Gas Stove Made.

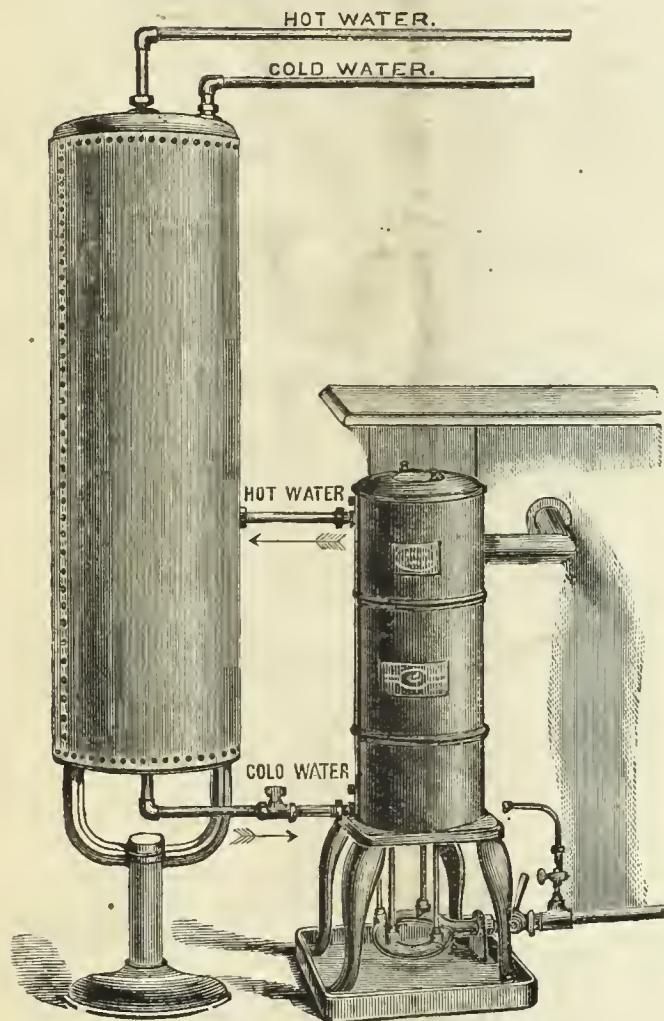

I.—Safety Hot Water Generator and Boiler.

Safety Hot Water Generator and Boiler.

Cut I. represents our Safety Gas Hot Water Generator and Boiler, arranged for home use. This most easy, quick, and economical way of preparing a warm bath, or for heating water for any domestic purpose, entirely supersedes any necessity for the use of ranges or stoves—a great comfort, particularly in hot weather. The boiler being self-filling, as the hot water is drawn off, can never become empty, thus preventing the possibility of any accident.

We beg to call attention to the cast iron pan which is now attached to the legs of the Generator (see illustration). This is to catch the drippings from the Coil, which many persons suppose come from a leak, when in fact they are produced by condensation. This condensation caused by the hot flame coming in contact with the coil filled with cold water.

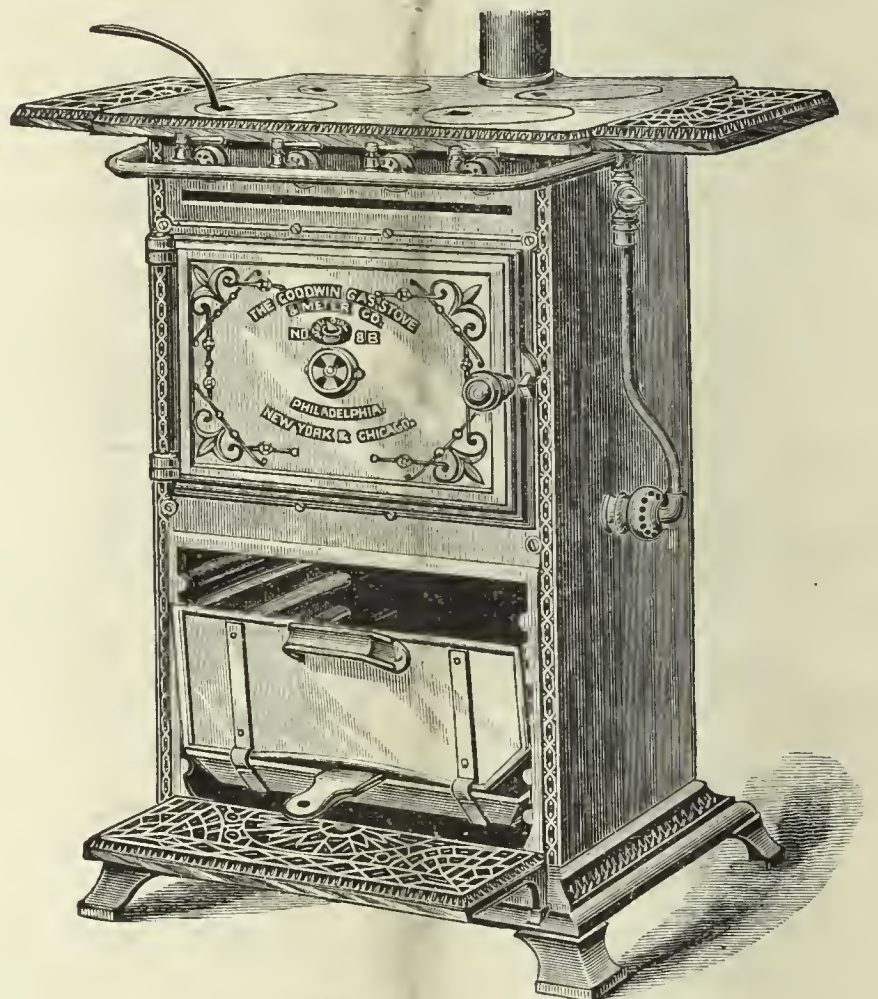

II.—Gas Cooking Stove No. 8 B.

New Style Gas Cooking Stove.

Cut II. represents our New Style Cooking Stove. As will be seen, it has an ornamented cast iron base and front, and extension shelves. The oven burner, which is atmospheric (unless otherwise ordered), is of an entirely new and improved pattern (patent applied for). The ovens are of greater capacity than those of the old style. The top, in conjunction with the outlet pipe, is designed to carry off all products of combustion; hence the outlet pipe must be connected with a flue, or the stove will not work properly.

This Stove has 4 boiling burners in top of hot plate. All fittings are nickel plated. We making this style of Cooking Stove in the following sizes—viz., No. 7 B, No. 8 B, No. 9 B, No. 10 B.

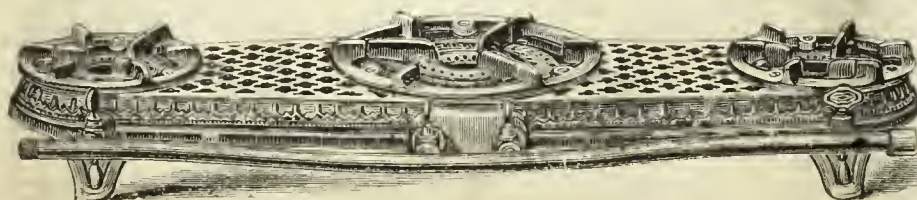

III.—Improved Hot Plate, No. 108.

New Style Hot Plates.

Cut III. represents our New Style of Hot Plates, of which we are making No. 106 (two small boiling burners), No. 107 (two medium sized boiling burners), and No. 108 (two medium and one large boiling burner). See new Catalogue and Price List for further particulars.

THE AMERICAN

GAS LIGHT JOURNAL

REDMAN KENN. N.Y.

PUBLISHING OFFICE No. 42 PINE STREET

DEVOTED TO THE INTERESTS OF ILLUMINATION, VENTILATION, WATER SUPPLY AND DISTRIBUTION, & GENERAL SCIENCE.

VOLUME XLVII.—No. 6.
Whole No. 678.

NEW YORK, THURSDAY, SEPTEMBER 16, 1887.

{ \$3 PER ANNUM,
IN ADVANCE.

A. M. CALLENDER & CO., Proprietors. C. E. SANDERSON, Manager.
JOS. R. THOMAS, C.E., Editor. T. J. CUNNINGHAM, Asst. Editor.

ENTERED AT THE POST OFFICE AT NEW YORK, N. Y.
AS SECOND CLASS MATTER.

Published on the 2d and 16th of each month, at No. 42 Pine Street, N. Y.

Terms of Subscription, Including Postage.—For the United States and Canada, \$3 per annum. European countries, \$3.50 (15 shillings—18 francs). All payments to be made in advance. Single copies, 15 cents.

Remittances should be made either by post-office order, registered letter, or bank draft on New York, payable to the order of A. M. Callender & Co.

Correspondence.—Wishing to make this JOURNAL a gazette of intelligent discussion to those of our readers who may wish to gain or give information on the subjects to which its columns are devoted, correspondence is solicited for publication from all who make the study of those subjects a pleasure or a profession.

The American News Company, Nos. 39 and 41 Chambers street, New York, are agents for this JOURNAL. Newsdealers will send orders to them.

Collections are invariably made directly from this office, for subscriptions, advertisements, etc. We have agents to solicit the same, but they are not authorized to receipt for money.

Books.—We will forward by express, at publisher's lowest rates, any book—scientific or otherwise—to any address in the United States or Canada. No books will be sent C. O. D.

CONTENTS.

An Asterisk (*) denotes an illustrated article.

OFFICIAL NOTICE—

American Gas Light Association..... 161

EDITORIALS—

The Coming Meeting of the American Association..... 162

Obituary Note—Chas. E. Putnam..... 162

Purification in Closed Vessels, and Avoidance of Nuisance in the Manufacture of Gas, by Wm. Young..... 163

The Preservation of Railroad Ties and Timber by the Use of Antiseptics, by Jos. P. Card 166

Regenerative Retort Firing System for Small Gas Works, by T. Blythe..... 168

Distribution by Alternating Currents..... 169

ITEMS OF INTEREST FROM VARIOUS LOCALITIES..... 170

St. Paul (Minn.) Proposes to Have a Grand Illumination—Making no Charge for Putting in Services—As to its Legality—The Proposed Sale of the Halifax (N. S.) Gas Works—Would Like to Get a Franchise—Wasted Gas—Consolidated—News from Birmingham, Conn.—Instructing the Inspectors—Incorporated—The American Gas Improvement Company—A Newsy Letter from Brother Dunbar—Sale of the Flushing (L. I.) Electric Light Franchise—Restored—A Brisk Trade in the Connelly & Co. Specialties—Another Gas Thief—The Halifax (N. S.) Gas Company Favors the Jarvis Furnace—Annual Election, Providence (R. I.) Gas Company—Public Lighting at Portland, Oregon—Topeka, Kas. Similarly Affected—Offering to Lease the Works—The Gleason Company Controls the Sale of the Gregory Burners—Something More about the Petition for the Town of Lake Gas Franchise—Another Opposition Company—Brother Cressler Keeps it Up—Going Ahead at Wichita, Kas.—Negotiating—Does it Mean a War of Rates?—New Gas Company—Electric Light at Louisville, Ky.

Western Waifs, by Diaphragm..... 173

Hints to Gas Managers..... 174

In New Quarters..... 174

The Market for Gas Securities..... 174

[OFFICIAL NOTICE.]

American Gas Light Association.

SEPTEMBER 10, 1887.

To the Members of the Association :

GENTLEMEN : The fifteenth annual meeting of the Association will be held, as already announced, on Wednesday, Thursday and Friday, October 19, 20 and 21. The Convention will be called to order on the morning of the first-mentioned day, at ten o'clock, by the President, Malcolm S. Greenough, Esq. As the local Committee of Arrangements has not completed all the details of the work committed to it, I cannot now give a complete programme of the Convention, but can lay before the members the chief features of the meeting.

As I said in my last circular, the difficulty of arranging for the accommodation of the members of a convention in New York city during the fall months increases rather than decreases year by year, so that it is now found impossible to provide for the care of all the members at a single hotel ; hence the Committee, in deciding on the headquarters of the Association, endeavored to secure one which would be adjacent to other hotels, in order that the members might be near each other, as the pleasure of being under one roof would be denied them. It has, therefore, been arranged that the headquarters shall be at the Sturtevant House, and accommodations for the members will also be provided at the Coleman and Grand. The Sturtevant House is situated at the corner of Broadway and Twenty-ninth street, and is run on the American plan; both the Coleman and Grand are run on the European system, the former being at Broadway and Twenty-eighth street, the latter at Broadway and Thirty-second street. Members should secure rooms in advance, by writing direct to the hotel at which they intend stopping.

The meetings will be held at Dockstader's Hall, directly opposite the Sturtevant House.

I am not able to state where the banquet will take place, but the date has been fixed for October 20.

The members still show a disposition to hold back in the matter of papers. At present we have the following promised:

"Fuel Gas," by Emerson McMillin, of Columbus, Ohio; "Illumination vs. Candle Power," by Alex. C. Humplreys, of Philadelphia, Pa.; "Utilization of Residual Products," by Chas. H. Nettleton, of Birmingham, Conn.; "The Advantages of Gas Companies Engaging in the Electric Light Business," by E. J. King, of Jacksonville, Ill.; "Water Gas," by Walton Clark.

From the above list it will appear that we have only five papers promised, but we need several more to fill out our time nicely. I sincerely hope that before the time comes around for sending out another notice our list of papers will foot up ten instead of five. I wish some of the members would decide on a subject for a paper and send me the title of the same at an early date. I would also suggest that the members might be thinking of the topics suggested by the foregoing list of essays, and come prepared to make the discussions on these papers very lively.

If a member has a subject in mind which he would like to have discussed at the meeting, I would be pleased to hear from him.

One member suggests as a topic for a paper the use of coke for mak-

ing steam. If any member has had special experience in this direction, and could give us the comparative cost of coke and coal when employed for this purpose, he would confer a favor on several members if he would prepare a paper on the subject.

Respectfully,

C. J. RUSSELL HUMPHREYS,

Secretary.

THE COMING MEETING OF THE AMERICAN ASSOCIATION

We presume it is needless, in view of the concise and forcible manner in which Secretary Humphreys has called the attention of the members to the fact, to say that but something over a month's time will have elapsed when the delegates to the Fifteenth Annual Meeting of the American Gas Light Association shall be assembled in business session. However, no harmful effect can follow from a reminder at our pen at this time that, if the fullest measure of true success is to be the portion of the assemblage, now is the time to prepare for the gathering; and it necessarily follows that such preparation, to be thorough, must be based on studious effort.

Although the Secretary quite properly hints that five papers will not overburden or overfill the hours allotted to the presentation and discussion of technical subjects, and we are completely at one with him in the hope that his next official notice will show that the spirit of progress has induced five additional contributors to enter the lists, we nevertheless must congratulate the Association upon the caliber of the men who have so far agreed to write for its delectation and instruction. Furthermore, while each and all of the gentlemen specified are well qualified to handle any division of the gas maker's craft, we must add congratulation over the aptness with which they have decided in selecting themes for elaboration. Take Mr. McMillin, for instance. The ubiquitous Columbus man has been, to our knowledge, a close student of the subject of "Fuel Gas" for years back; and, in fact, he is now engaged in a study of the best system for manufacturing and supplying fuel gas to the residents of his city. Following Mr. McMillin comes Mr. Nettleton, of Birmingham, who elects to consider that important subject, the "Utilization of Residual Products." This gentleman has made the residuals account quite an important item in the economy of the Derby Gas Light Company, and the success gained by him there ought to be duplicated at other places in the States with much more frequency than is the actual case. From Mr. Nettleton's accurate practical knowledge of the subject that he is to treat upon, we are certain that his remarks will be listened to with great interest. Next in sequence appears the name of Mr. E. J. King, of Jacksonville, the worthy son of a father whose memory is yet fragrant and green in the affections and respect of the members of our craft. Mr. King was one of the first to seriously consider the wisdom of operating the combined supply of gas and electricity. Studious, painstaking and the soundest of reasoners, but one result can follow the reception of what he will say on his chosen theme said result being the knowledge that those who listened heard the judgment of one who knew whereof he spoke. Mr. W. Clark, of New Orleans, is also thoroughly qualified to handle "Water Gas" in all its phases, since he is far from occupying a tyro's position in regard to its manufacture. Last of all we welcome the appearance of Mr. A. C. Humphreys to the list of paper writers, and venture to assert that something new and important will, by means of his contribution, be added to the literature of this vexed (although decidedly mystifying and far from determined) question—"Illumination vs. Candle Power."

Coming now to the suggestion thrown out by Secretary Humphreys that a valuable topic for a paper is to be found in the steam raising capacity or value of coke, we sincerely hope that the gage will be accepted. It may seem rather forward to express a preference in these columns as to whom we would be especially glad to hear from in respect of the mooted question, but no harm can ensue to the Association did we hint that either Mr. Thos. Curley, of Wilmington, Del., or Mr. Jas. Somerville, of Indianapolis, Ind., would fill the bill completely. A better proposition than the last would seem to be set forth were we to expunge "either," substituting "both" therefor.

It is quite on the cards for all the visitors to know that New York is at its best in the nut-brown month of October, the only drawback (if it can be so called) being, despite the multiplicity and hugeness of our city's hotels, the difficulty of housing at comparatively short notice all heads beneath one roof. The tact and generalship of that division of the local Committee of Arrangements, however, has been most happily shown. The Sturtevant, Coleman and Grand Hotels are within easy hailing distances, are well kept and appointed hostelrys, and are in the very heart of the city, with the certainty that any desired point can be

easily and comfortably reached, and by almost any sort of transportation method wished. To crown all, Dockstader's Hall cannot fail to prove a most desirable place for assembling in business session, all of which goes to prove that in respect to accommodation the members are amply secured. In the meantime, remember the hints of your wide-awake Secretary, who will make no complaint should you, within a fortnight, compel him to double up the list of papers promised for the coming October gathering.

OBITUARY NOTE.—CHARLES E. PUTNAM.

By E. G.

In the issue of the JOURNAL, dated August 16, you make brief mention of the death of Mr. Chas. E. Putnam, of Davenport, Iowa. Not only was Mr. Putnam an able and upright member of the Iowa bar, but his well-known interest in all that pertains to the welfare of the community led him, at an early period, to devote a large share of his time to the development of the business of the Davenport Gas Light Company, of which corporation he was President at the time of his death.

No other event of late years has more greatly stirred that beautiful Western city than the passing away of this splendid type of a perfect citizen, for all denominations of religion, and all classes of men, united in testifying to his worth, and in bearing witness to the loss which they have sustained through his demise.

The burial service was held at Davenport, on July 22, and was attended by numerous friends, numbers of whom traveled many miles in order that they might be present at the obsequies over their loved dead. The Rev. Mr. Williston, who conducted the services, spoke feelingly in his address of the worth and character of our departed friend. In referring to the personality of the deceased, the speaker said:

"His always seemed to me a knightly soul. Dishonor could wound no nature more keenly than his. I have found myself since he died involuntarily repeating to myself the old Platonic formula for a finished humanity—'the true, the good, the beautiful'—and so my heart would chant it again now, its votive strain to the memory of the friend who will return no more. I know how his lip would have curled if ever a bad thing was done in his sight. I am sure he never stooped and did another a wrong. The mean cases did not seek his defense. Rascality passed the firm of Putnam & Rogers by. Here were two upright men. For a quarter of a century they held their names above reproach—champions of the sacredness of law, and brave enough to keep their practice clean."

Mr. Putnam was born at Saratoga, and sprang from one of the oldest and most honored families of that place. Like many others of his day and time, the West presented an attraction and charm for his vigorous intellect and indomitable energy, and having removed thereto we note, during the first year of his residence in that great section of the country, he became united in marriage to Mary Louise Duncan, the accomplished daughter of Joseph Duncan, Governor of the State of Illinois—one of the men who contributed largely to the welfare and progress of that State in its developmental days. Their marriage created almost an ideal union—the energy, cheerfulness and talents of the wife, appreciated and recognized by the husband, filled up the measure of his broad and useful life.

A friend, bearing testimony to the many-sided culture and talent of the deceased, remarks:

"One of the characteristics of Charles E. Putnam was the unflagging interest he maintained in literature, science and art. Pressed by the demands of an extensive business, and with the cares of a large family, his mind never succumbed to these necessities, but he was ever master of circumstances. With calmness, wisdom and energy, he gave minute and careful attention to every detail of business, to every desire of his growing family, but there remained the reserved force and sentiment of an elevated character. He found time for the advancement of those general interests in education, science and art which belong to a large community, and also for individual study and enjoyment in this direction. His friends, while sincerely lamenting their loss, can derive consolation in remembering that his beautiful

"Soul, of origin divine,
God's glorious image freed from clay,
In heaven's eternal sphere shall shine,
A star of day!

The sun is but a spark of fire,
A transient meteor in the sky;
The soul, immortal as its sire,
Shall never die."

Purification in Closed Vessels, and Avoidance of Nuisance in the Manufacture of Gas.

[The following interesting paper was read by the author (Mr. William Young) at the last meeting of the North British Association of Gas Managers.]

The subject of this paper is so wide in its range—embracing as it does all the stages of gas manufacture, from the liming of coal in the retorts, and the treatment of gas during condensation and scrubbing, to the final stages for the elimination of the bisulphide of carbon—that it would be impossible to enter into minute details in the limited time at our disposal. I therefore purpose confining my remarks to the broad principles involved, more particularly in the removal of carbonic acid, sulphuretted hydrogen, bisulphide of carbon, and the sulpho-hydrocarbon compounds, by the ammonia and pure hydrocarbons derived from the coal itself. Before entering, however, upon the main subject, I may be permitted to make some allusion to matters that have suggested themselves to mind as having an intimate bearing upon the avoidance of nuisance during the manufacture of gas.

You are all aware that the quantity and nature of the impurities which are to be removed at the purification stage proper are principally dependent upon the constitution of the crude material used in the production of the gas. Were it possible to obtain a supply of a pure hydrocarbonaceous substance—such as refined petroleum or mineral oil—there would be no impurities. But in coal we have the hydrocarbonaceous portion combined with oxygen, nitrogen, and sulphur—all of which lead by combination to the formation of impurities which have to be removed from the gas before it is fit for consumption. The sulphur is undoubtedly the most objectionable of these substances, as the compounds resulting from its combustion tend to the formation of acid products which are very injurious and destructive. It depends very much, however, upon the manner in which the sulphur is present in the coal, what is the nature of the combinations of sulphur produced during destructive distillation, and the comparative ease or difficulty of removing them from the gas. Broadly, the sulphur may be present in the coal in two forms of combination. It may be associated with the organic portion of the coal, or it may be combined with the mineral substances such as go to form the ash, lime, iron, etc. When in the former state of combination it may be evolved as sulphuretted hydrogen, which is easily removed by any of the well-known processes. But it is also frequently given off in combination with hydrogen, carbon, and possibly nitrogen, in a form sufficiently volatile not to be removed during condensation, or by any process at present in use. This, therefore, is the sulphur which unavoidably accompanies the gas, and leads to its banishment from all places where the acid sulphur compounds resulting from its combustion have proved injurious. When the sulphur is in combination with the mineral matter, it is more or less fixed and retained in combination, dependent upon the substance with which it is combined. If with lime or the alkalis, it remains in combination; but if associated with iron, as pyrites, it is more or less set free. And I have no doubt that it is from this source that the compound bisulphide of carbon is principally derived, which gives us so much trouble to remove.

You are aware that sulphide of carbon is decomposed when heated, commingled with hydrogen or water vapor, at a temperature far short of a gas-making temperature. You are also aware that the sulphur is not liberated from its combination with the iron by heat below that which is destructive of bisulphide of carbon in the presence of water vapor or hydrogen. Taking these facts into consideration, it is reasonable to infer that the sulphide of carbon is principally formed during the latter stages of the destructive distillation of the coal, when there is a great mass of incandescent carbon, and the temperature is sufficiently high to liberate part of the sulphur from the pyrites. The sulphur coming in contact with this incandescent carbon when there is a comparative absence of water vapor or hydrogen to form sulphuretted hydrogen, unites with the carbon, and forms carbon bisulphide. Should this inference prove correct (and some crude experiments which I have made lead me to believe that it is), then it follows that if water vapor or hydrogen were admitted into the retort, so as to commingle with the gas at a temperature high enough to decompose the bisulphide of carbon, we could get rid of this compound by having the sulphur converted in the easily removable sulphuretted hydrogen. If steam were employed this could be effected, if it were not introduced so far in as to lead to its decomposition by the fixed carbon, and to the production of carbonic acid. Indeed, it is questionable if it would be necessary to introduce the steam into the retort at all, as, from the recent investigations of Mr. W. Foulis on the temperature of the gas in the stand-pipe, it would appear that it would only be required to introduce the steam into the stand-pipe.

I have no doubt that the comparative freedom of the gas from bisulphide of carbon, when the coal is mixed with lime, is principally due to the liberation of the water of hydration of the lime during the later stages of the distillation, when any sulphur which is given off from the mineral matter in the coal is formed into sulphuretted hydrogen. The sulphur left in combination with the mineral matter after carbonization is also liable to create a nuisance; for when sulphide of lime is brought into contact with water and carbonic acid at comparatively low temperatures, the sulphur is liberated as sulphuretted hydrogen. The sulphur left in combination with the iron is rapidly given off as sulphurous acid when the coke is exposed to the air, and when being quenched, as sulphuretted hydrogen. During the time that the coke is wheeled out into the open air, and during quenching with water, I have good reasons for believing more sulphur is liberated into the air than accompanies the gas from the same coal as at present purified. The sudden quenching of the coke also tends to its disintegration, and the production of breeze or small coke; and there is also a quantity of ammonia liberated which is lost.

It has occurred to me that this nuisance could be avoided without loss, if not with profit, by cooling our coke in close vessels. Of course, in this as in other remarks on purification in close vessels, I refer to the larger-sized works. I should propose that the coke, as it comes from the retorts, should be run directly, by an endless chain arrangement in hutches, to the top of a cooling chamber, in much the same way as the spent shale in oil works is at present taken to the top of the *debris* heap. The cooling chamber in its construction would resemble a close-topped blast furnace or lime kiln. The upper part of the chamber would consist of an annular steam producer; the lower being a structure composed of a shell of sheet iron lined with firebrick. The coke would be tipped into the top of the cooling arrangement through a hopper and valve, and coming into contact with the sides of the steam producer, rapid evaporation would take place. The steam thus generated would be taken down to the bottom of the cooling chamber, and ascending through the coke, the latter would be cooled, while the former would become gradually heated, until, passing through the last introduced coke, it would be partially decomposed, setting free sulphuretted hydrogen and ammonia, which would be drawn off by a pipe, and the ammonia and sulphur recovered by any of the well-known processes. The coke, thus rendered free from sulphur, and less disintegrated by the slow cooling, would be more valuable as a fuel, and could be drawn off at the bottom by a suitable opening, at a rate proportional to that at which it was introduced at the top.

Having made these preliminary suggestions, I will now pass on to the main subject of this paper—viz., the principles involved in the purification of coal gas from carbonic acid, sulphuretted hydrogen, bisulphide of carbon, and other sulphur compounds, by means of the ammonia and hydrocarbons produced from the coal employed in the manufacture of the gas. My reasons for discussing the principles rather than their application are because they have not as yet been practically tested on a large scale, and because a knowledge of the theory (which I believe is not so general as might be desired) will enable those interested in the subject to more easily understand the various processes that have been patented for purification in close vessels, and put them in a position to judge of their respective merits. I trust this excuse will be considered sufficient by those present who are already familiar with the chemistry and principles upon which these processes depend.

Purification of gas by ammonia resembles that by lime, with this important difference—that the one purifying agent is a solution of an alkaline gas, which can be handled by pumps through pipes, and applied in closed vessels; whereas the other is a solid, entailing the periodical opening of the vessels wherein it is used, causing a nuisance which is entirely avoided in the case of liquid purification. In many respects, however, the processes are closely analogous; and as purification by lime is well understood, a comparison of the two systems may perhaps be the best means of conveying to the mind a clear conception of purification by an alkaline solution. Were I to take a piece of limestone, or carbonate of lime, and heat it to bright redness, the carbonic acid would be dissociated or wrenched from the lime or oxide of calcium, and, being gaseous, would leave the solid lime behind. On allowing the lime to cool, and adding water, it would be converted into calcium hydrate, in which state it is strongly alkaline, and on being placed in the purifiers absorbs the acid gases, carbonic acid and sulphuretted hydrogen, and becomes carbonate and sulphhydrate of lime. But as the affinity between lime and carbonic acid is stronger than that between lime and sulphuretted hydrogen, by the continuous passage of a gas containing carbonic acid, the lime may be wholly converted into carbonate in the first purifiers, and the sulphuretted hydrogen driven forward to the last. The sulphhydrate of calcium

so formed combines with the bisulphide of carbon so as to form the sulpho-carbonate of calcium. The carbonated lime, on being removed from the purifiers, may be reburnt and converted into calcium oxide, to be again applied as a purifying agent. When spent lime is to be reburnt in this manner it is necessary that any sulphuretted hydrogen present should be replaced by carbonic acid, as the affinity between lime and sulphur is so great at high temperatures that a sulphide is formed which, by exposure to the atmosphere, becomes oxidized into sulphate, having no purifying effect, and remaining only as so much inert matter, entailing a large and useless expenditure of heat. The importance of this fact was recently illustrated in a case in which the writer was consulted, when analysis showed that the so-called revived lime contained less than 20 per cent. of calcium oxide; the remainder being sulphate and silica and other foreign matter. While I go on to examine the action of ammonia when used for gas purification, I wish these facts to be kept in mind, as they have some resemblance to the waste of energy that may attend the revivifying of ammoniacal solution.

I have here a piece of carbonate of ammonia. If I attempt to dissociate the carbonic acid therefrom by heating it, you will observe that it disappears into the air. Both the alkaline ammonia and the carbonic acid, being gaseous at the temperature of dissociation, pass away together in the form of gas. I will drop this piece of carbonate into a test tube, and then heat it. It is dissociated—the mixed gases, carbonic acid and ammonia, passing away till the lower temperature in the upper part of the tube allows them to recombine, and to be again deposited as carbonate on the sides. It is evident, therefore, that we cannot reburn or revivify solid carbonate of ammonia, as in the case of lime, when the alkaline substance is a refractory solid. We further see that the temperature at which carbonic acid is dissociated from ammonia is far lower than in the case of lime. Indeed this temperature is considerably under the boiling point of water.

I have here another test-tube containing a little water, which I bring to the boiling point, and into this water (which I withdraw from the flame and allow to fall below 212° F.) I drop this piece of carbonate of ammonia. You will observe how violently dissociation takes place. This proves the dissociating temperature of carbonate of ammonia to be under 212° F.; but it also proves something else. There is now no deposit of carbonate of ammonia in the upper part of the tube, as was the case when the dry carbonate was dissociated. You will observe that when I thrust a lighted match into the tube it is at once extinguished; showing the presence of some heavy gas which is not a supporter of combustion. You will also observe that on adding this acid solution of litmus to the water it is immediately changed blue; showing that the water holds an alkali in solution. How has the presence of the water so modified the results? You are all aware of the great affinity or solvent power of water for ammonia. We employ this affinity to free our gas from ammonia. You are also aware that water dissolves carbonic acid gas; but its solvent power is very small—only about 1-600th that which it has for ammonia.

Now, when I dropped the piece of carbonate of ammonia into the water slightly below the boiling point, dissociation at once commenced; the chemical affinity between the ammonia and the carbonic acid being completely overcome by the heat. The relative solubility of the ammonia led to its almost complete absorption by the water, whilst the comparatively insoluble carbonic acid escaped as a gas, accompanied by a small quantity of ammonia. Sulphuretted hydrogen is, if anything still more easily dissociated from the ammonia than carbonic acid; and therefore, in this respect, ammonia possesses advantages over lime. If, then, I were to keep up the temperature of the water in the tube, and drop a further quantity of carbonate of ammonia in, the water would by and by become saturated, and both the ammonia and the carbonic acid would be evolved together; and were the temperature reduced to less than about 180° F., dissociation would cease. These facts limit the strength of the solution of ammonia salts which can be dissociated, under ordinary conditions, to those containing 2½ per cent. or 1-40th of their weight of ammonia—that is, for every ton of caustic ammonia produced, there would have to be heated to the temperature of dissociation about 40 tons of water, entailing the employment of very large dissociating plant; and the bringing of such large quantities of weak solutions of ammonia into contact with the gas would also necessitate very extensive purifying plant, and in this respect would incur a cost similar to that of reburning and purifying with lime containing 80 per cent. of foreign matter, to which I have already referred.

Accordingly many attempts have been made from time to time to obviate this difficulty. In 1870 Mr. F. C. Hills devised a plan by which comparatively weak solutions were concentrated by distillation; and in 1881 the writer, and shortly after Mr. Claus, patented processes by which

the ammonia is separated from the weak solutions in the anhydrous or gaseous state, and directly mixed with the gas to be purified. These processes had undoubted advantages; but they had also counterbalancing disadvantages. The quantity of fuel required to distil the ammonia from the weak causticized solution was very great, and the commingling of the ammonia gas with the coal gas direct led to troublesome deposits of carbonate of ammonia in the vessels in which they were brought into contact. Some difficulty was also experienced in regulating the quantity of ammonia gas to that necessary to effect purification; while the reabsorption of the ammonia had the disadvantage already mentioned of requiring large plant. All these facts pointed to the desirableness both of using and revivifying the ammonia in solution and in a concentrated condition. It has been seen, from the experiment, that the ammonia can be revivified or dissociated from the carbonate in a weak solution, owing to its solubility in water. It is therefore evident that if we were in a position to increase this solubility at the temperature of dissociation, a condition of things would be induced which would enable us to effect the object desired. I have pointed out the difficulties which beset our path in the process of purification by ammonia, and I have endeavored to explain the principles by which we have thus far been guided. I will now direct your attention to a physical law which has been taken advantage of only in the process lately devised by myself.

The quantity of gas taken up or held in solution by a liquid is in direct proportion to the pressure, and in inverse proportion to the temperature; and thus the boiling of water depends upon the vapor tension, which is increased in direct ratio to the pressure. On the other hand, chemical affinity is not subject to the same law; and although, in some cases, the temperature at which chemical changes take place is considerably modified by pressure, it does not materially interfere with the dissociation of ammonia from the salts formed by its union with carbonic acid and sulphuretted hydrogen. Bearing these facts in mind, it will readily occur to you that if, instead of dissociating the gases from the solution of ammonia salts under atmospheric pressure, we did so in strong vessels under a much higher pressure, we could employ a stronger solution with little or no loss of ammonia, and the separation of the gases could be conducted more rapidly from the higher temperature which could with safety be employed. I am sorry that the experiments, which have led to this conviction in my mind, are of such a nature that I cannot avail myself of the pleasure of performing them in your presence. I may, however, explain that they were made with solutions of carbonate and sulphide of ammonia, about three times the strength of ordinary gas liquor, in a strong malleable iron still under different pressures; and that the ammonia passing along with the gases was carefully estimated, as well as the quantity held in solution, together with the carbonic acid and sulphuretted hydrogen. The results were such as were anticipated. As the pressure under which dissociation was effected was increased, the quantity of ammonia gas passing away with the acid gases was diminished, whilst the quantity held in solution in a caustic state in the still increased with the pressure.

Having considered the physico-chemical principles in virtue of which ammonia may be separated from its salts in strong solutions, let us now examine the arrangement of such mechanical apparatus as may be necessary effectively and economically to secure the end in view. In order to revivify the ammonia by its separation from the carbonic acid and sulphuretted hydrogen with which it has become combined in purifying the gas, it must be forced into a strong vessel and raised to a temperature above that at which dissociation takes place to render it caustic; and before it can be again used as an absorbent of impurities it must be cooled to ordinary temperature. This heating and cooling can, in a measure, be done by what is known as regeneration, or, in other words, transferring the heat of the caustic solution flowing out of the vessel in which decomposition is effected to the cold solution of carbonates and sulphides flowing in. As, however, the solution of these salts has to absorb the small quantity of ammonia which accompanies the acid gases as they are set free, it is evident that the interchange of heat should take place after the inflowing solution has been employed for that purpose.

I now come to the mode in which the ammonia should be applied for the purification of the gas. When lime is employed, the gas is made to enter the purifier which contains the nearly exhausted or saturated lime, and the gas leaves the purifier which has been last charged; and so, when water is used to absorb ammonia, the pure water is brought in contact with the pure (or nearly pure) gas, and is drawn off where the gas enters, and after it has become nearly saturated with the ammonia from the crude gas. This system is quite suitable in cases where the purifying agent is a solid, such as lime, or a fluid difficult to volatilize, such as water; but it is inapplicable to a highly volatile substance such as ammonia.

I have here a Woulfe's bottle containing a solution of caustic ammonia, such as would be employed in purifying the gas. Through this I will pass the gas supplied to this room. You will observe that, on allowing the gas to blow against this turmeric paper, it is at once turned brown, indicating that some of the ammonia has been taken up in diffusion. To show you that the quantity is considerable, I will displace the air in this flask by the gas, and by stopping the neck with a cork having a kneed tube inserted in it, I convert the flask into a modified Cooper tube. I will now fill the knee of the tube with water, and bring it in contact with the ammonia by shaking it. On plunging it into water and removing my finger, the water rises in the neck of the flask, showing the quantity of ammonia that has been absorbed. Now I have here another Woulfe's bottle with a solution containing exactly the same percentage of ammonia as the other bottle, though in this case it is not caustic, but is combined with carbonic acid and sulphuretted hydrogen—in fact, just such a liquor as would result from the saturation of the caustic ammonia in the first bottle with these gases. In performing with this bottle the same experiment as with the other, you will see that the turmeric paper is not so rapidly affected, and the water does not rise into the neck of the flask—showing, indeed, that only an extremely small portion of ammonia is diffused through the gas. I will now pass the gas first through the caustic solution of ammonia, and then through the solution containing the salts of ammonia, and collect the gas in a flask as before. On absorbing the ammonia with pure water, you will see how very slightly the volume is reduced. These experiments show that, in solutions containing equal quantities of ammonia, it is more volatile, and more readily diffused through the gas, when in the caustic state than in a state of combination; and not only so, but that the solution containing the carbonates and sulphides has the power of absorbing a considerable quantity of caustic ammonia from the gas, and holding it in solution.

Now, in employing ammonia as a purifying agent, it is desirable to retain the solution in as concentrated a form as possible. But it is evident, from what we have just seen, that if the revived solution were first brought in contact with the nearly pure gas, a large amount of the caustic ammonia would be diffused through the gas and carried forward, and the purer the gas the larger would be this amount. The solution would thus be rendered weaker, and the gas so contaminated would require washing or scrubbing to recover the ammonia. If, however, we reverse the order in which the ammoniacal solution and the gas are brought into contact—that is, bring the impure gas and the revived solution of caustic ammonia first into contact, and cause them to flow, not against each other, but in the same direction—then a large quantity of the impurities would at once enter into combination with the ammonia, and form compounds which are comparatively fixed; and as solutions of these can absorb caustic ammonia gas, any ammonia volatilized from the solution into the gas will be reabsorbed by the solution of salts of ammonia as they come in contact by flowing together. Consequently the gas will pass from the purifying vessel with comparatively little ammonia in diffusion. The solution of ammonia will be retained proportionably stronger, and the gas will require less treatment and smaller vessels for freeing it from the diminished quantity of ammonia in diffusion. There are other advantages attending this method of using the ammoniacal solution. The chemical affinity between carbonic acid and ammonia is greater than that between ammonia and sulphuretted hydrogen, and, therefore, by allowing the solution of ammonia and the gas to travel together, the carbonic acid will, to a large extent, be first absorbed; and more particularly will this be the case in strong solutions of ammonia, due to the fact that in weak solutions the superior chemical affinity of the carbonic acid is partly counteracted by the greater solubility of sulphuretted hydrogen in water. The carbonic acid being first removed will allow the formation of sulphhydrate of ammonia at the final stages of purification; and, as you are aware, this compound of ammonia has the power of combining with and removing bisulphide of carbon from the gas.

There are many other minor matters relating to purification by ammonia—such as the recovery of the cyanogen compounds and sulphur, and the simultaneous production of salts of ammonia—that deserve attention. To deal with these, however, would require more time than can now be given thereto.

Having now taken into consideration the main principles involved in the application of ammonia to the purification of gas, it might be well, before leaving the subject, briefly to recapitulate the various salient points. We have thus seen: That the ammonia, being gaseous at ordinary temperatures, cannot, as in the case of the solid alkaline substance lime, be dissociated and separated by heat from its combination with acid gases. That the separation of the alkaline ammonia from the acid gas can only be effected by the introduction of the solvent affinity of water.

That under atmospheric pressure the solvent affinity of water at the temperature at which dissociation takes place is only capable of holding in solution from 2 to 2½ per cent. of ammonia gas. That the employment of such weak solutions would involve the use of very large plant, both for the dissociation of the acid gases from the ammonia and also in the application of ammoniacal solution to the acid gases and other impurities in the coal gas; that it would entail a larger fuel expenditure; and that, in endeavoring to increase the chemical action between the impurities in the gas and the ammonia by concentrating the weak solution, or rendering the ammonia gaseous by distillation, the cost for fuel would be increased, as also the dimensions of the dissociating and distilling vessels. That by effecting dissociation under pressure, stronger solutions can be revived without loss of ammonia, owing to the fact that the ammonia is much more solvent in water under increased pressure. That by employing the solution of salts of ammonia, formed by the union of the impurities and the caustic ammonia, to absorb and hold in solution the surplus caustic ammonia, the strength of the solutions is not materially reduced in their application to the purification of the gas. Also that the employment of such stronger solutions enables the work to be done with smaller and simpler apparatus, and with the expenditure of less fuel. The mechanical arrangements for carrying these principles of purification into effect have already appeared in the pages of journals devoted to the industry, and to these I beg to refer you.

It now only remains for me to make a few remarks upon the purification of coal gas from the more complex and difficultly-removable sulphur compounds of carbon, hydrogen, and probably nitrogen. I have already had the pleasure of making three communications to this Association on the subject. The first was in 1876, in a paper upon the utilization of waste shale gases and the recovery from these gases of the liquid hydrocarbons diffused in them, when I drew attention to the affinity of these hydrocarbon fluids for sulphur compounds. Again, in 1879, I went more fully into the subject, describing particularly the physical conditions necessary to the successful abstraction of the sulphur compounds from coal gas. In the succeeding year I again referred to the subject, and gave practical illustrations of the method by which the hydrocarbon fluid should be applied to the gas to remove these compounds. Since communicating these papers millions of gallons of volatile hydrocarbon fluids have been recovered from the waste shale gases. So far as I am aware, however, no attempt has been made on a practical scale to apply them to the purposes described in these communications. I have no doubt, however that they, or kindred hydrocarbons from our tar, will in future play an important part in gas purification, more particularly in conjunction with liquid purification by ammonia. For details relating to the subject I must refer you to these papers, as time will not permit us to more fully investigate it. As, however, in experimenting upon purification by ammonia I had occasion to return to this matter, I may be permitted to make a few remarks more especially bearing upon the use of ordinary coal tar naphtha, or the first of the distillate of tar, for this purpose.

Ordinary coal tar naphtha, as you are aware, consists of a series of hydrocarbons having different boiling points, and identical in constitution with the hydrocarbons which are found diffused through coal gas, and which confer upon it much of its illuminating power. The presence of these hydrocarbons in the tar is partly due to the approach to saturation of the gas with them, but also in part to the solvent affinity of the heavier oils, with which they are associated during condensation, robbing them from the gas. If the isolated naphtha were presented to the gas, the gas would take up the hydrocarbons present in such proportions as would lead to approximate saturation; but if a quantity of heavy oil from the tar were added to the naphtha, equivalent in solvent affinity to the original tar with which it was condensed, then there would be a balance, and there would be neither absorption nor volatilization. Now, suppose if, instead of presenting the whole of the naphtha to the gas, we were to remove the benzol portion, and then bring the denuded naphtha and heavy oil into contact with the gas, it is evident that the solvent affinity of the naphtha, being balanced for all the other members of the hydrocarbons present in the gas, but disturbed in the benzol portion, the latter would be at once dissolved or absorbed out of the gas by the other hydrocarbons until the balance of solvent affinity was restored. Suppose, instead of the benzol part, we were to isolate and remove any other part, a similar disturbance of balance of relative solubility or diffusion would be effected, with like results. It is evident, therefore, that the character and constitution of the naphtha derived from the tar of a given coal will bear a relation to the character or constitution of the hydrocarbons diffused through the gas, and that the more perfect the process of condensation, the more certainly will this be the case—that is, if the tar is rich in benzol, so will be the gas; and, therefore, it follows that if the

naphtha is rich in volatile organic sulphur compounds, so also will be the gas. In the same manner, a coal that yields a large quantity of ammonia will produce a strong ammoniacal liquor. But just as the liquor is strong in ammonia, so will it tend to remain in diffusion in the gas, the solvent affinity of the water being balanced by the tendency of the ammonia to diffuse itself through the gas. Now, if we were to take the ammoniacal water condensed from the gas in the condensers, distil out the ammonia, and cool the denuded water, and then bring it into contact with the gas in the scrubber, we could, by its renewed solvent affinity and the fractional manner of its application, remove every trace of ammonia. If, then, by the solvent affinity of water we can remove all traces of ammonia from the gas, why should we not be able to remove the complex sulphur compounds diffused through the gas, by the solvent affinity of naphtha? The only essential condition which could possibly interfere with such a result would be that the naphtha does not possess a solvent affinity for the sulphur compounds equal to that of water for ammonia, or at least sufficiently great to make it available, and that the sulphur compounds could not be conveniently separated from the pure hydrocarbons.

The nature and constitution of the more complex sulphocarbonaceous compounds present in crude naphtha, and diffused through coal gas, are not well known. They are, no doubt, dependent upon the original form in which the sulphur is in combination in the coal from which they are derived, but also on the manner in which the coal has been carbonized. Bisulphide of carbon is undoubtedly present in considerable quantities amongst these sulphur compounds, and that they are all solvent in the associated hydrocarbons is shown by them remaining in solution, and not being precipitated by concentration. That, like bisulphide of carbon, they are not very stable compounds, is proved by some of them undergoing decomposition at comparatively low temperatures. Washing with sulphuric acid removes a very large proportion of the sulphur compounds, which might indicate that the sulphur forms part of a basic hydrocarbon containing nitrogen. This is further indicated by the fact that, when decomposed, ammonia or a volatile base is frequently evolved. Alternate washing with aqueous solution of caustic soda and sulphuric acid, and distillation, render the naphtha almost free from sulphur compounds; but the most convenient way of rendering the naphtha sufficiently pure and suitable for removing the sulphur compounds from coal gas is by simply washing with sulphuric acid, and then with an alcoholic solution of caustic soda.

I have here three Woulfe's bottles containing such purified naphtha. This fourth bottle contains bisulphide of carbon. By burning the gas supplied to this room after being brought into contact with the bisulphide of carbon, the fact that it takes up a portion in diffusion is at once made evident by allowing the products of combustion to come into contact with a disc of slightly alkaline litmus paper. You observe it is at once changed red by the sulphurous acid fumes resulting from the combustion of the bisulphide of carbon vapors diffused through the gas. You will further observe that the gas has little or no illuminating power, due to the fact that the presence of these vapors has a very injurious effect upon the illuminating power of the gas, and also because the hydrocarbon vapors in the gas, being soluble in the liquid bisulphide of carbon, are, to a great extent, removed; thus beautifully illustrating the balance that must exist between the nature of the vapor diffused through a gas and the liquids with which it comes in contact. I will now bring the gas, thus highly charged with the bisulphide of carbon vapors, into contact with the purified naphtha in the other three bottles. You will notice, on my lighting the gas, that the illuminating power is nearly restored, and that the products of combustion no longer change the color of the litmus paper; showing that the pure naphtha has dissolved out of the gas the diffused bisulphide of carbon vapors, and that a quantity of naphtha vapors have been diffused through the gas. The rapidity with which this action takes place is shown on lighting the gas after it has only once been in contact with the pure naphtha. You will observe that some considerable time elapses before the alkaline litmus paper is changed red.

The volume of bisulphide of carbon vapor which can be dissolved out of the gas by the pure naphtha is very large. I have here a glass flask which I fill with the gas saturated with bisulphide of carbon vapors; and by means of this perforated cork, I attach into the neck of the flask this tube with the knee at the lower end sealed with water, add a small quantity of purified naphtha, and bring it in contact with the gas by shaking. On removing my finger under water, you will notice how rapidly the water rushes in to take the place of the very large volume of vapor absorbed out of the gas.

It now only remains for us to consider how purified naphtha could be most effectively and most economically applied in purifying the gas

from the complex sulphur compounds. The system described in the paper I had the pleasure in communicating to this Association at Perth, in 1880, is probably one of the best—that was by commingling the naphtha and ammonia sulphhydrate in the one vessel, so that as the solvent affinity of the naphtha reduced the sulphur compounds diffused through the gas to the liquid form, they would thus be brought into contact with the sulphhydrate of ammonia, and any of the sulphur compounds capable of entering into chemical combination with the sulphhydrate of ammonia would be at once removed, leaving the naphtha in a fit condition to again absorb a further quantity. The naphtha, on becoming charged with the sulphur compounds not removable by the sulphhydrate of ammonia, would be drawn off at the bottom of the purifying vessel, and subjected to the treatment to render it again pure.

From a careful consideration of the subject, and from many experiments, I feel convinced of the practicability of the entire purification of gas by means of the liquid products derived from coal; and I have every confidence that the matter only requires to be taken up by an energetic member of this or some kindred Association, who is practically engaged in the manufacture of gas, to make it an accomplished fact in the near future.

The Preservation of Railroad Ties and Timber by the Use of Antiseptics.

[A paper read by Mr. Joseph P. Card, at the last meeting of the Western Society of Engineers.]

The antiseptics that have been used up to the present time, to any considerable extent, in the preservation of railway ties and timber are: Corrosive sublimate, kyanizing; sulphate of copper, Boucherie; chloride of zinc, Burnettizing; and dead-oil, creosoting.

Many others, however, have been tried in the past or 50 more years, and abandoned for one cause and another, which I will not attempt to explain, but will confine my remarks to those now in use.

Corrosive sublimate is the most powerful poison of them all, and its antiseptic properties are some 50 or more times greater than sulphate of copper or chloride of zinc; that is, a solution of one part corrosive sublimate in 10,000 parts of water would, according to the best authorities, be more than an equivalent to sulphate of copper, diluted, one part in 400, or chloride of zinc, one part in 200 of water, which is about the minimum at which they will preserve.

In treating timber with corrosive sublimate, it is generally placed in large wooden vats for one day for each inch in thickness, not counting the day it is put in or taken out, or say 10 days for an 8 in. by 8 in. square stick.

The handling of the timber after treatment has to be done with care, or serious consequences may follow. The solution used has generally been one part in 100 of water.

The treatment with sulphate of copper has generally been done by the Boucherie process, or in copper cylinders, on account of its corrosive properties, while the treatment with chloride of zinc is done in iron cylinders, which cost, say, ten times less than copper. All three of these salts being more or less liable to be chemically changed or washed out of the wood, and as the chloride of zinc has, under most conditions, when injected in proper quantities, answered equally as well, and being cheaper and more economically handled, it has come more generally into use than either of the others. In fact, comparatively speaking, corrosive sublimate and sulphate of copper have practically gone out of use.

Chloride of zinc has served a good purpose in the preservation of railroad ties in Germany, while in England the treatment has not been satisfactory—in fact, has been abandoned. Now, why this great difference in results? The road-beds are, as I understand, alike (rock-ballasted); consequently, the drainage is the same. It must be on account of the impurities absorbed into the ties, from England's moist climate, which changes gradually the chloride into a non-antiseptic, for rainfall, as a rule, will not, so far as my observations go, wash it out. It takes more than rain; in fact, it means submerging it in water, and this would hardly occur on a rock-ballasted roadbed. If a tie were reasonably dry and in rock ballast, and it should rain, it would absorb moisture slowly as it rained; the flow would be inward, taking more or less of the salt with it, for any of the soluble salts mentioned will, to a certain extent, move around through the wood in whatever direction the moisture goes. When it rains, it goes inward or towards the center; when the moisture evaporates, to the point of evaporation. I have had this tested by analysis, to my entire satisfaction.

If ties were submerged, or partially so, in water for any considerable time, the chloride being of greater specific gravity than water, its tendency would be to go out of the ties rather than inward, or to equalize

with the water surrounding them. Again, if the ties were in sand (like the Rock Island ties, which I will mention later on), the result would be, when your sand was moist or wet, they would absorb moisture where they came in contact with it, and as it gradually moved to the point of evaporation, which would be the top or exposed portion of the tie, it would carry with it more or less of the chloride. This constant, or, at certain seasons of the year, long-continued evaporation, weakens, in my opinion, the strength of the chloride at point of contact with the ground or moisture below the minimum of its preserving properties, and in the case of the Rock Island ties, which were in clean sand, they gradually decayed where they came in contact with the ground, but remained sound on top, as a general thing.

Again, should there be impurities in the ground or water surrounding the ties, or in the rainfall, that would combine with the chloride or any salt and transform it into a non-antiseptic, as oxide of zinc, the change would be more or less rapid, and it is in this way that I account for the bad results with chloride of zinc in England; and from rainfall, if the ties are on rock ballast.

I know of Burnettized gunwood ties that were placed in cinder and slack-coal ballast in 1880 (the cinders and slack came from a coal mine dump which had been burned over) which were worthless in 12 months after being placed in the track, while ties treated at the same time, that were placed in sand, are sound to-day, or were when I examined them last year.

I do not mean to say that all cinders and slack will produce this result, but these did; neither do I wish to convey the idea that the changes mentioned heretofore occur in a day. Some of them may in a month, or, as in the case of the Rock Island ties, their average life was over 15 years.

There is a section of some 20 miles of the Union Pacific Railroad where the ties have been preserved, ever since the road was first built, by the soil in which they lie.

With reference to creosoting or the use of dead-oil in wood-preserving, if you inject a sufficient quantity of oil (of proper quality, after steaming and vacuum) into ties or timber, they will remain sound so long as the oil remains undisturbed, if it enters the wood but $\frac{1}{2}$ in., or even less, on the sides of, say, a 10 in. by 10 in. stick of timber, notwithstanding the oil remains practically where it is placed at the time of treatment, and does not diffuse through the wood, like chloride of zinc, and for the following reasons:

Dead-oil contains carbolic and other acids, which are more or less soluble in water, and enough of these acids combine with the moisture in the wood at the time of treatment to destroy the fermentable or other matter then in the wood, that tends to decay, and any impurities or germs of decay thereafter coming from the outside will have to pass through the dead-oil, and in doing so are destroyed or rendered inert.

The trouble with creosoting is to get the dead-oil where you want it (it will stay where you put it), and the cost. The trouble with a mineral salt or chloride of zinc is to keep it where you put it, or where it places itself shortly after treatment, if the work on your part is properly done.

Having given you my experience, as well as ideas as to the benefits to be expected from the proper use of mineral salts and dead-oil when used by themselves, I will now submit for your consideration and discussion before this Society the process known as the "zinc-creosote" process, which consists in the use of both dead-oil and chloride of zinc in combination, for the preservation of railroad ties from decay, as well as protection against the attacks of the teredo where timber is placed in the sea.

For railroad ties, bridge-timber and the like, or where timber is subjected to no considerable moisture, as when placed on or in the ground, the process is as follows:

After preparing the timber in the usual way, by steaming and vacuum, the dead-oil is run into the cylinder, and such quantity as may be desired is forced into the wood.

For railroad ties or timber, I would recommend, say, $\frac{1}{2}$ gallon to the cubic foot, or $1\frac{1}{2}$ gallons to the tie. A less amount may be found to answer. After the timber has been treated with oil, the oil removed and the cylinder charged with chloride of zinc, when, by pressure, it can be made to enter the wood, pass through and beyond the oil, and impregnate by diffusion that portion of the wood that the oil will not penetrate, especially where timber is not well-seasoned or dense like oak. The aim of this process is to get the benefit of the dead-oil treatment where ties or timber come in contact with the ground or moisture, with one-half or less oil, besides having those portions of the wood not penetrated by the oil impregnated by the zinc chloride. The zinc chloride, surrounded as it is by oil, should be protected for a long time in railroad ties or bridge timber against moisture. I find that less than

one-half the quantity of oil used in ordinary creosoting can be distributed by this process through every portion of the wood penetrated by the greater quantity injected in the usual way.

Creosoting, as practiced abroad, unless a much larger quantity of oil is used on railroad ties than is used in England (6 to 10 pounds to the cubic foot), is of little value, in my opinion, unless a chair is placed under the rail, to take the wear, for the following reasons:

Where dense woods are used—and, in fact, it is the case also with many of those woods which are considered porous—the heart-wood will take the oil but skin deep; consequently, the oil is in time worn off by the rail, decay begins, and at the worst possible place the spike becomes loose and the tie valueless.

This is probably the reason why there were so few American creosoted ties shown at the Exhibition of Railroad Appliances, in 1883, and the few that were there had been treated to at least 2 gallons of oil to the cubic foot. If I am not correct, I would ask what has become of the thousands that have been treated in the past 30 years in this country, where we use no chairs under the rails?

I have here one of a lot of ties treated by a Mr. Pelton some years since for the Chicago, Rock Island & Pacific Company, and put in the track near Englewood, Ill. It was taken up in May, 1883, to be shown at the Chicago Exposition of that year. These ties were treated in 1872 by what is known as the Seely process, and, although they contained but little oil (less than 4 lbs. to the cubic foot), they were sound, so far as examined by me, where they came in contact with the ground, but commenced to decay (so I was told) under the rail as soon as the oil wore off, and not before.

If a sufficient quantity of oil is used to impregnate the ties to a considerable depth at point of contact with the rail (which means for oil 50 cents, or 6 gallons to the tie, and this applies to soft woods only and not to oak), a good result would be obtained; otherwise, a chair must be used.

If you will show me one tie that has served a good purpose, I will convince you that it was treated to, at least, 6 gallons of oil, or a chair had been used. Not but what a much less quantity would preserve it from decay, if it were placed in the ground as a post, and undisturbed; but should you remove the oil at the ground line—it matters not to what extent, so that the untreated timber is exposed—you will find your creosoting of little value, and this is the experience of all.

Mr. J. W. Putnam, of New Orleans, in a letter to the Chairman of the Committee on Preservation of Timber of the American Society of Civil Engineers, says: "With reference to creosoting, wherever the coating is broken, and the air, with its dust, allowed to come in contact with the untreated wood, decay follows, and extends in each direction from the opening," and he is but one of the many who make this or similar statements.

The Burnettized ties on the Chicago, Rock Island & Pacific Railway, near Englewood—and, so far as I have examined, those on other roads, also, where the work was well done—were sound under the rail, but decayed where they came in contact with the ground. Mr. Alexander, in his report of March 23, 1882, to Mr. Hugh Riddle, then President of the Rock Island Company, says: "I have made a careful examination of the Burnettized hemlock ties we laid in the main track just west of Englewood, in November, 1866, last summer, and found at least 75 per cent. of them still in the track, and, in my opinion, in such a state of preservation that they will be serviceable for two or three years longer. Some 5 or 6 of these ties were taken out of track, and found to be sound and solid in the center, and only decayed to the depth of $\frac{1}{2}$ to $\frac{3}{4}$ in. on the surface and sides. The rail has not worn into these hemlock ties to any greater extent than would have occurred with oak, and they hold a spike fully as well as the oak tie. The pine and cedar ties that were Burnettized at the same time have worn out in the 15 years' service and have disappeared. The tamarack have held out about the same as the hemlock." Continuing, he says: "My experience is that untreated hemlock ties decay first in the center or heart, when the spike becomes loose and the tie crumbles; but these treated ties are sound in the center, which shows that where the chloride of zinc is not washed out, the wood is in a perfect state of preservation."

I saw these ties a short time after they were taken up, and examined those remaining in the track in June, 1883 (they had then been down over 17 years), and found them to be sound under the rail, with hardly an exception. I also had the sound wood from several of these ties analyzed, and found them to contain from 0.05 to 0.14 per cent. of chloride of zinc to weight of the wood when dry.

Again, in the same report (March 23, 1882), Mr. Alexander says: "In 1872, we laid in second track, east of Washington Heights, about 5,000 hemlock ties that were subjected to the creosoting process. These ties I

do not believe to have been thoroughly treated. They seemed to be tolerably sound at the bottom, but are badly decayed on the surface, and the rail wears into them to a much greater extent than it does into those that were treated with chloride of zinc. There is probably not more than from 30 to 50 per cent. of these creosoted ties now in track, and these will, no doubt, be all taken out this summer.

I examined these ties, or what there was left of them, in June, 1883, finding few then in the track, but was fortunate, however, in finding several hundred that had just been taken up and piled along the track.

If I am correct, what can be expected of creosoted ties with but 6 to 10 lbs. of oil to the cubic foot, if used, as they are in this country, in direct contact with the rail, and what must we do to get best results in the preservation of our ties? Use a chair, as in England, or open, porous woods, and inject 50 to 75 cents' worth of oil into each tie; or will a double treatment, first with dead-oil and then with chloride of zinc, answer the purpose—the dead-oil to preserve the outer or exposed parts, which it will do, and the zinc chloride the central portions, which the oil does not penetrate to any considerable extent in our most desirable woods? So far as my observations and experiments go, I am satisfied that time will demonstrate that dead-oil and chloride of zinc, injected into ties and timber as proposed, will give the best results for money invested, and where dense woods are used, especially for ties, the best result, without regard to cost.

You may say that the old way of creosoting closed the pores, thereby keeping out moisture. Dead-oil will not keep moisture in or out of wood, like paint, tar, or pitch, for any considerable time. Moisture will not enter a creosoted tie above the surface of the water surrounding it, or without pressure; neither will it enter, except under same conditions, where the fiber is oiled. This being the case, your ties, under most conditions, will remain dry, and the zinc chloride should be protected.

Again, you seldom see decay in wood the fiber of which has once been covered with dead oil to such an extent as to be seen by the eye. The zinc-creosote process will, as I said before, distribute one-half or less oil in every part penetrated by the greater quantity when injected in the old way, and in such quantities as can be readily seen.

You may say, Would it not be better to first inject the chloride, and then the dead-oil? If the treatment were reversed, you would have to remove a portion of the moisture before the oil could be injected. Wood being one of our best non-conductors of heat, the process would be tedious, and timber or ties would be more or less injured by the long continued application of the heat required to evaporate sufficient moisture. In fact, the only cheap and practical way would be to air-dry or stack the timber until sufficient moisture has evaporated, and then apply the oil. I do not believe there would be anything gained by so doing, and it would add greatly to the cost.

With reference to the treatment of piling with dead-oil, as protection against the teredo, the old way is to inject all the oil the timber will take (which depends on the piles being more or less dry and the kind of wood operated on)—from one to three gallons to the cubic foot. The object of the zinc-creosote process is to economize in the quantity of oil used, and nothing more, and consists in first injecting, say, two-thirds (one-half may be found to answer) of the quantity used in the old way, and then, by substituting some other fluid for the oil, as chloride of zinc, air, or water, by pressure, compress or force the two-thirds previously injected solidly to the center, which leaves the two ends—the one in the mud or ground, the other above water—with their fibers virtually painted with the dead-oil, while the center of the pipe, or that portion in the water, is as well treated, and contains as much oil as would be the case if the whole quantity used had been oil. I would prefer an antiseptic for the second injection, as it would help to preserve that portion above water from decay.

Regenerative Retort Firing System for Small Gas Works.

[At the last meeting of the North British Association of Gas Managers Mr. T. Blyth, of Kingskettle, read the following paper. The paper is reprinted from the *London Journal*.]

Having been asked by the Committee of this Association to write a paper on the regenerative system of retort firing for small gas works, it was not without some hesitation that I agreed to approach the question, knowing, as I do, that I have had very little experience in the working of regenerative furnaces compared with many of those now present.

Having had a conference with Mr. MacPherson, of Kirkcaldy, on the regenerative system, and received a full explanation of the system, and being about to put in new retorts, I resolved to have a trial of this system, with an oven measuring 5 ft. 6 in. in breadth, and 6 ft. in height from the floor level, with three -retorts 14 in. by 16 in. by 8 ft. long.

[The author then explained, by the aid of a diagram, the construction of the regenerator adopted by him. It consists of flues built of ordinary firebricks set on edge, and bricks placed flat on the top of these, forming 4-inch flues. The heat passes from the producer under the top retort, and travels backward and forward along the flues until it makes its exit by the chimney. The secondary air enters by the middle one of the three bottom flues, passes to the back of the oven, then enters the flue above and comes forward, and joins the gas from the producer.]

The heat in the setting is perfectly uniform from one end to the other. The flues are built so that they are easy of access should they happen to get choked up; but after having had them working for six months, and damped them down for the season about the middle of March, I have never had any trouble or obstruction in the flues. When I examined them this summer, when building a new producer, I found there was only about a shovelful of ash in the two uppermost ones; the others were quite clean.

As regards the size of the producer, it is built with circular bricks to form a 2-foot cylinder inside. It is 4 ft. in height, and the bottom of it stands only 2 ft. under the floor level. There is a clinkering port 6-in. square, built in the front at the bottom of the producer. My reason for adding this is that I had some trouble in clinkering, owing to the mouth-piece of the top retort being right over the producer cover, preventing the free use of the clinkering bar, and thus exposing the workman for a longer period than is desirable to the intense heat from the open producer. But by this means free access can be had to the bottom of the producer if required. In my experience the clinker forms on the producer 4 or 5 inches above where the primary air enters; but it is easily removed when proper access is obtained to it. I also had a $\frac{3}{4}$ -inch malleable iron tube bent round the outside of the producer. This tube was connected with a small cistern, and had three stopcocks on it for water to drop into the portholes to raise steam; but it was of very little use, unless the water was dropping on the hot coke.

I have now another arrangement which I may explain. I procured a vessel to hold 30 gallons of water, and placed it on the top of the bench. This I filled with water by a force-pump, and from it lead a pipe for steam, which passes down the front of the bench. The heat which rises from the bench is sufficient to produce as much steam as I require. The cover of this vessel is surrounded by a water-lute 3 in. deep, to prevent the steam from escaping.

One advantage to be gained by this system in small gas works, such as those of Kingskettle (where only one man is on the night shift, and one on the day shift in the winter time—the fires having to be banked up by myself in the summer), is the little trouble it necessitates. As we all know, a stoker's work in small gas works is different from that in large gas works. In small works a stoker has coals to break, purifiers to clean, lime to prepare, tar to pump, etc.; and no doubt, anxious sometimes in the short days to get forward with his work, he may forget to attend to the furnace at the proper time—and filling up a furnace with cold coke when it is almost burned down means, in my experience, a quarter of an hour's loss of heat.

I hold that the regenerative system is the most practical and independent system of heating retorts in small gas works, as the producer can run from four to five hours with very little attention, and you can easily see by looking into the oven, by the flow of gas from the producer, when the fuel is nearly exhausted and requires recharging. Another advantage gained by this system is the conservation of heat in the retorts at night when banked up. By filling the producer full either of hot or cold coke you can run it from six to eight hours, as may be required, by the working of the secondary-air slides and the damper at the stalk. By doing this you will have a firmer heat in the morning; and this is of great importance in small gas works. With the old system, however, I always found that in the morning, after the furnace had been banked up all night, although the heat looked well, I could never produce the quantity of gas, by 200 cubic feet, from the first charge of three retorts that I did in the ordinary working. It also takes about half an hour after the clinkering of the furnace to get it into proper working order.

In my short experience with the regenerative furnace, when it had been banked up for six or eight hours I was able to produce from the first charge within 20 cubic feet of the ordinary working; and this certainly is a great advantage. Another advantage of the system is that less coke is required by $\frac{1}{2}$ cwt. every four hours. I had a similar oven working alongside this one, with three retorts of the same dimensions fired with solid fuel, and it used $1\frac{1}{2}$ cwt. of coke every four hours, while the regenerative system required only 1 cwt. every four hours, which enabled me to use more of those cannels which yield a coke of inferior quality. This is also a great saving, for I have found, in purchasing

such cannels, that 5s. and upward per ton can be saved on coal giving an inferior coke, which will produce the same quantity and quality of gas as those producing a good coke.

The expense of the oven, retorts, and producer as constructed at Kingskettle I find to be—

Three new retorts, at 36s. 3d. each.....	£5 8 9
650 firebricks.....	2 2 5
Bricks and castings for producer.....	1 18 0
Total.....	£9 9 2
Average cost per mouthpiece.....	£3 3 0½

I know the importance of this subject demands something very much better than I have laid before you; but I have merely given you the rough outline, as the time at my disposal would not permit me to do more.

At the close of the paper—

Mr. W. Foulis (Glasgow) said he thought Mr. Blyth deserved very great credit for the manner in which he had designed and constructed the furnace he had shown them. He had got it up in a way that certainly must be exceedingly cheap, and easily constructed. For small works he did not know that anything more perfect could be designed that would serve the purpose better. He was very much struck with Mr. Blyth being able to get such good results from so small a producer—a producer only 2 ft. by 4 ft. He considered it was a step in the right direction, where small settings were required. His purpose in rising was just to express his satisfaction with the paper which had been read, and with Mr. Blyth's enterprise in the matter. One thing he would say, that the method of getting steam, by placing the cistern on the top of the retort bench, was exceedingly ingenious.

Mr. J. Turnbull (Lauder) expressed the opinion that Mr. Blyth's furnace was considerably in advance of the one he (Mr. Turnbull) described in the paper he read before the Association last year, and it was in the right direction. They were all very glad to see an advance made, even for small works, and he thought Mr. Blyth deserved the thanks of the meeting for the very able paper he had presented.

The President, in closing the discussion, said he agreed that Mr. Blyth deserved their best thanks for coming forward with his paper, and for the interesting sketch he had given of his setting. Mr. Turnbull had alluded to the paper he gave the Association last year, and he (the President) thought Mr. Turnbull might go away gratified that his paper had been an incentive to Mr. Blyth. There was no doubt that in country gas works a great advance might be made by the introduction of gaseous fuel, and the sooner this was accomplished the better. He asked the members to give Mr. Blyth a hearty vote of thanks for his paper.

The motion was carried by acclamation.

Distribution by Alternating Currents.

The following report (read by Mr. M. M. Slattery, Chairman of Committee appointed to investigate the subject of the "Electrical Distribution by Alternating Currents") was presented at the Boston meeting of the National Electric Light Association:

One short year ago the commercial success of the branch of electric lighting in which induction coils are used was, by some of our best authorities, considered very problematical, but practical use of the induction system has not only succeeded in commercially converting high tension electricity to low tension for electric lighting purposes, but also high tension theoretical opponents by practical demonstration of facts.

Upon the occasion of the last convention, the extensive use of the induction system received its first authoritative indorsement by our esteemed friend, Dr. Otto A. Moses, and although he was by some considered over enthusiastic in his statements, time has served to prove the correctness of his views, and the realization of many of his anticipations.

We will go back six months, and, mentally, what do we see in this business from here? A few experimental plants scattered about in various parts of the country struggling for public recognition, and with the innumerable detail difficulties which dog the footsteps of every new departure; difficulties the magnitude of which are usually in proportion to our ignorance of their nature, and therefore more frequently than not unduly magnified.

Now, what have those difficulties been, and has the past six months' experience enabled the manufacturing companies engaged in this branch of business to eliminate them?

We find there were three factors in the induction system that required

all the ability of the electrical engineer to work out and place upon a proper footing, namely, the dynamo machine, the induction coil, and the disposition of the external circuit to take the best advantage of the use of the induction coil.

Of course, there were alternating dynamos in existence, as were also induction coils, before this branch of business had acquired any prominence, but they were not such as would meet the new requirements.

We will first take the dynamo. It will be familiar to all of you that no matter how intimately acquainted you may be with the construction of dynamo machines, when you start in to build a new type, your previous experience, however valuable it may be, does not enable you to foresee innumerable detail difficulties which will assuredly develop with practical use, and which take time to ascertain and remedy.

Well, so far as we have been able to learn the weaknesses which developed in this apparatus were first, the liability of the current to jump across the coils in the event of the field being excited with the armature circuit open. This open circuit sometimes happened by a dead cross occurring in some place in the mains, blowing the fuse at the dynamo, thus opening the circuit, and then the field being fully excited, the armature would generate an exceedingly high electromotive force for an instant; the current, under the circumstances, would be very liable to jump across the coils of the armature, and other hurtful effects to the machine would ensue; the remedy for that was inserting at every branch in the external circuit a junction fuse, and at various points along the mains and sub-mains section fuses to such an extent as to make an open main a remote contingency. It was also found that the armatures heated excessively, owing to the presence of the plaguey Foucault currents. It was found that this evil could be almost wholly suppressed by building the armature without iron, and avoiding as much as possible the use of masses of metal in proximity with the armature coils. In this connection Siemens' early type of alternating dynamo, slightly modified to meet the new requirements, might read us a lesson.

It was a bold step when the alternating dynamos were constructed with iron cores, and those who make this class of machine for this high tension incandescent business might give us some interesting information. To my mind this iron core construction speaks of disagreeably high temperature. I do not say that they will not be able to present a rational theory why this evil may not be, or has been, greatly modified, but the fact existed in the past, and as far as we have been able to ascertain stands unrefuted at present. One thing, however, is pretty evident, that just now this type of machine appears to be finding a rather extensive use, evidencing that it must be doing good work. So much for the alternating current dynamo, a machine destined to play a most important part in the future electric lighting business, and in the light of the past experience no doubt should exist in the minds of anyone here that these dynamos in practical use are now almost, if not quite, as reliable as any other dynamo; while coupled with this is the important factor of a pretty close self-regulating property attainable in this system, without the necessity for any particular method of winding, that property following chiefly as the result of the use of the induction coils. It is satisfactory to know that during the probation of this system every accident of any importance which has occurred to the dynamos has been of a purely mechanical nature, and our mechanics have reduced them to a minimum.

No doubt the induction coils have been the source of considerable anxiety; not because there was any obstacle in the way of obtaining high electrical efficiency, as this latter appears not to have been by any means a difficult problem to solve. The source of greatest trouble has been, as far as I can learn, that of insulation. In what form will the weakness appear has been a question often asked himself by a timid electrician, and as usual the most unlooked-for troubles developed. At one time an unaccountable defect in the insulation of the secondary coil would occur, cutting out a number of convolutions, thereby causing an annoyance by reducing the incandescence of the lamp in its circuit; the remedy was simple—increase the insulation of the wire and exercise still greater care. The same accident would still more frequently happen to the primary coil; the same remedy applied overcame it; sometimes a number of the layers of the primary coil would thus be suddenly cut out, resulting in the passage of a much heavier current than the fuse in the coil box had carrying capacity for; the fuse would then melt and possibly draw an arc that you had a great deal rather do without if you could; the remedy for that was, keep on insulating the primary coil layers from each other until the trouble ceased, and increase the distance between the ends of the primary fuse to such an extent that when the latter melted, an arc, no matter how great its volume, would not be able to bridge over the distance which, after all, was calculable because the E. M. F. was constant. Then, again, metallic con-

tact would take place between the induction coil and the iron box in which it was mounted, and if that box happened to be placed anywhere near a ground, possibly unpleasant electrical experiences might be related in wet weather. It was again only a question of looking out for the insulation to reduce such defects to a minimum; well, the insulation appears to have been looked out for, as the smooth and safe working of that branch of the business would now seem to testify, and to-day that part of the system can be made as reliable, simple, and as easily disposed of as any other part of an incandescent system.

Thus the two new and troublesome factors have gradually and surely been strengthened for their future work.

The next in the system, viz., that method of distribution which would enable you to utilize the induction coil to the best advantage, although apparently presenting the simplest problems at the outset, has required a great deal more thought than was anticipated. It was found that no particular rule, as in the case of low tension distribution, could be carried out, the methods of distribution varying with the condition of the district in which you had to distribute. In some cases the wires were run out from the central station through the center of distribution, and tapped at any point along the route where lights were required. This was the earliest and simplest form of distribution, and answers perfectly well for comparatively small installations, it being desirable to keep the loss in the mains down to about two per cent., and perhaps about two or three per cent. in the induction coils, so that the incandescence of the lamps should not vary appreciably throughout the system—this arrangement of the circuit may be carried out in small and very scattered towns where it has been found to answer admirably. In other cases where the district is more densely populated, and a large installation is required, the inductoriums are placed in the centers of distribution and used like so many stationary dynamos, the high tension primary current, with comparatively small conductors, feeding each of these centers, the secondary or distributing circuit being taken where lights are required; still other methods of distribution are carried out, but what has been stated in this connection will serve to show that again the past year's familiarity with the business has given an opportunity to perceive and profit by many advantages the system offers.

One of the last, but by no means the least, points that I shall touch upon in this interesting subject is the question of comparative cost of the main conductors required in installation of an induction and low tension incandescent plant. Not at all infrequently we shall find ourselves called upon to figure upon a plant like this:

From the source of generation to the point of distribution is one mile and a half, making a three-mile circuit: at the point of distribution you are required to distribute some 400 16-c. p. lamps, at, say, 5 per cent. fall of potential, which appears to be about the limit allowed the induction system. The conductors for this purpose in the induction systems now in use would be No. 2, Brown & Sharpe, which will cost about \$230 per mile. In the case of the low tension installations upon the low tension system, you would require a conductor costing about \$1,050 per mile.

Should you be required to distribute throughout the whole of the length of the circuit, wire such as is used for ordinary arc lighting purposes would be amply sufficient for the induction, and of course a proportional reduction may be made in the low tension.

Now, a great many exaggerated statements are made with regard to the dangerous shocks to be expected from this alternating current, and while I am not prepared to say that the physiological experience of a shock from a thousand-volt dynamo is the most agreeable thing in the world, I am prepared to say that the shock is by no means as severe as that received from a continuous current dynamo of the same voltage. A few weeks ago a man showed me his hands, which were horribly burned. He had received a shock from an 1,100-volt dynamo, and he said, with a visible tremor in his arms, as if the recollection of that shock was still vividly impressed upon his mind, that he experienced the effect of that shock for more than a week afterward. A friend of mine was testing a 400-light, 1,050-volt alternating dynamo, fully loaded, only a few days ago, and going towards the machine his foot slipped and he fell quite close to it; in his confusion he quickly reached out his hands and unfortunately placed them directly upon the poles of the dynamo. He said from where he fell to the wall behind him was about fifteen feet, and it seemed to him as if that dynamo was suddenly converted into an electrical gun, and he got shot across the room until the velocity of his movement was interfered with by the wall. There was scarcely the appearance of a burn on his hands, merely a pin's head matter, while the effect of the shock was felt by him only for a few hours. It might be said that the difference of effect of the shock was owing to the difference in the temperament of the two men; that may be so, but I have received

three pretty severe shocks from a 1,000-volt alternating machine, and however much I may have felt inclined to dispense with the shaking up it gave me, the experience has been of value to me—one cannot have everything.

One word more in conclusion. The induction system has evidently come to stay, not because enthusiastic advocates think or say so, but because the expert public, the central station public, have practically indorsed it, because it more nearly than anything else meets their immediate and anticipates many of their future requirements. More especially is its advent doubly welcomed just now with this misconducted overhead conductor warfare pressing on every side, and which is every day acquiring seriousness in proportion to the increase of copper wire in the air, and I think that this system, with its comparatively small mass of conductors, will postpone for a considerable time the necessity of going under ground with the electric light wires until more extended experiments shall have given us the confidence in underground systems that experience in the past has materially shaken.

ITEMS OF INTEREST FROM VARIOUS LOCALITIES.

ST. PAUL, MINN., PROPOSES TO HAVE A GRAND ILLUMINATION.—A St. Paul correspondent, writing under date of 2d inst., says that "those who witnessed the grand street illumination in this city during the progress of the State Fair last year, and expected to see but a mere repetition of that spectacle this year, will be most agreeably disappointed. All the pleasing features of last year's illumination are to be reproduced, but new designs will be shown to make a sight that will completely outshine St. Paul's previous efforts in the direction indicated. The entire work of designing the plan of the illumination has been relegated to the able management of Wm. A. Slyke, who, ably seconded by the earnest efforts of many leading citizens, has been unremitting in his labors, and his promise is sufficient guarantee that everything will be in readiness at his end of the line when the Fair opens. The details of the lighting arrangements are about like the following: A row of lights will answer for the side illumination of Third street, from Sibley to Wabasha street. Beginning at the corner of Sibley and Third streets, large cross-arches will be erected at all the street crossings, up to Bridge square, at which point it is intended to place a lighting design of striking effectiveness and beauty. Besides the cross-arches at the street corners, in the center of each block heavy double semicircles of lamps will be thrown across Third street. Over the sidewalks lengths of tubes have been run to the buildings on either side, to serve the double purpose of supporting the tubing along the curbstones, and also to carry a number of incandescent electric lights. The sidewalks will have a line of lights extending from Sibley to Wabasha streets, and the arches at the street corners, with the intermediate arches in the center of each block, will form an illuminated covering or canopy over the roadway. On Wabasha street double arches will be placed at Fifth street, and near the Capitol. The line of light on the sidewalks will extend from Third street to the Capitol. Other lines of illumination follow on Robert street, from Third to Seventh; on Jackson, from Third to Seventh; on Sibley, from Third to Seventh; and on Seventh, from Jackson to Broadway, with four arches within that distance. Colored globes (six different shades) will cause the illumination to have a rich effect. For instance, the arch at the corner of Third and Sibley streets will be finished in ruby colored globes; the globes on the next arch on Third street are to be of an amber hue; at the corner of Third and Jackson blue globes will be employed, while at the corner of Third and Cedar an arch of ruby globes, surmounted by a crown of crystal, will be the fact. The crowning triumph, however, of the illumination is intended to occur at Bridge square. Surrounding the electric light mast at that point arches of colored globes will run to all the street corners, and to posts on West Third street. This will be joined by a large ring of tubing completely encircling the mast. On this ring spires of light are to be arranged, and trees of colored globes are to be placed on all the arches, the whole forming a magnificent canopy of lights, the effect of which it is believed will surpass anything heretofore attempted in a similar direction. Let me close my hasty and, I fear, hardly intelligible description by saying that during Fair week Third street is to be closed to vehicle traffic every evening at 7 o'clock, when the roadway is to be thoroughly swept in order that it may be used for a public promenade. Concerts are to be given every evening, three bands having been engaged to play at stands to be erected in the center of every alternate block." It will be noted that our correspondent fails to say whether or not gas is to be called on to furnish the greater portion of the light required, but we presume he means us to infer that such is to be the case. At all events, "Fair Week" promises to be a bright one

on the St. Paul calendar, and we would like to be on hand to witness the spectacle.

MAKING NO CHARGE FOR PUTTING IN SERVICES.—The Municipal Gas Company, of Albany, N. Y., advertises that those who wish gas services laid on to their houses, etc., can have that work done at the Company's expense, provided notice of such intention is given to the Company on or before Nov. 15 next. That is liberal, and should result in the placing of many new meters.

AS TO ITS LEGALITY.—Corporation Counsel Green (Chicago, Ills.) it is said will present his report in (regard to the legality or otherwise of the Gas Trust formed some time ago in that city) to the Common Council, in time to be read at the session to be held on the 26th inst. He has forwarded a list of questions to those in subsidiary control of the companies forming the Trust, and expects to incorporate the replies thereto in his message to the Council. Some of the legal and financial experts of Chicago confidently assert that the Equitable and Consumers' Companies' charters, upon a fair construction of their terms, preclude them from legally acting as members of the Trust.

THE PROPOSED SALE OF THE HALIFAX (N. S.) GAS WORKS.—It was generally supposed that all the preliminary details necessary to a transfer of the Halifax plant and franchises had been arranged, but that conclusion appears to have been premature, for, according to advices bearing date of August 29, it seems that only a small attendance of shareholders greeted Chairman Boak at the meeting (held on August 27) which was to decide the question. Our informant then goes on to say that, "While the meeting was supposed to be of the most secret nature, all the facts have leaked out. The Hon. Robt. Boak read the offer of J. R. Bothwell for the purchase of the franchises, privileges and property of the company, which proposition was, in effect, as follows: \$500,000, one-half to be paid within thirty days of the acceptance of the offer, the remainder within sixty days; Mr. Bothwell to complete all existing contracts, and the other assets of the company, in the shape of coal, etc., to be paid for in addition to the purchase money named. The buyer agreed to deposit \$100,000 in cash, to bind the contract, \$50,000 of which was to be deposited on or before —, the remainder shortly thereafter, \$50,000 to be forfeited if the buyer did not adhere faithfully to the terms of the proposition. [It should be said here that the Bothwell bid had been accepted by the Directors at a previous meeting, the session under consideration being called to secure the acquiescence of the shareholders.] Bothwell, it seems, shortly before the shareholders' meeting, repented his rashness, and failed to deposit the \$50,000, giving as a reason therefor that he had been informed by his solicitor that, before the company could transfer its property, it would have to secure the passage of an enabling legislative act, and that as the Legislature would not meet for several months his (Bothwell's) financial arrangements had been sadly interfered with. When the state of affairs was disclosed to the shareholders, they, after much discussion, passed a resolution to the effect 'that the Directors have power to negotiate a sale at such time and terms as they deem advisable.' This resolution does not amount to much, for, no matter what the Directors decide upon, such decision (according to the Company's franchise) is of necessity subject to ratification by the shareholders. Meanwhile the projected 'deal' hangs fire, and some people predict that it will never 'go off.' In my opinion, this is too valuable a property to be hawked about the market."

WOULD LIKE TO GET A FRANCHISE.—Towards the end of last month the projectors of the Economic Light and Heat Company asked permission, through an ordinance submitted to the Council of Lake, Ills., to lay gas mains through the streets of the town. They agreed to supply gas for public purposes at price not to exceed \$1.25 per thousand cubic feet; to others, gas for heating purposes at \$1.25, and gas for illuminating demands at \$1.50. The gas was to have an illuminating value of not less than 25 candles. The matter was referred.

WASTED GAS.—In Omaha, Neb., something over a fortnight ago, a gas main passing under the Eighteenth street bridge was fractured, and the Gas Company lost thereby about 150,000 cubic feet of gas.

CONSOLIDATED.—The Meriden (Conn.) Gas Company and the Meriden Electric Light Company joined forces on the 1st inst. The capital stock was adjusted at \$250,000, and Mr. George R. Curtis, formerly President of the Gas Company, was elected President of the combined venture.

NEWS FROM BIRMINGHAM, CONN.—We note that the Derby Gas Company is building a dumping station on Derby avenue, on a plot of land recently purchased from John Coleman.

INSTRUCTING THE INSPECTORS.—Hereafter, in consequence of a resolution passed by the Philadelphia authorities, the Department of Public Works has been requested to instruct its inspectors of gas meters to leave a copy of their report, showing the state of the gas meter, with each householder when the monthly readings have been made.

INCORPORATED.—Articles incorporating the Cicero Water, Gas and Electric Light Company to operate at Oak Park, Ills., have been filed. The capital stock is returned at \$65,000, and E. S. Conway, O. W. Herrick and W. M. Luff are named as the incorporators. Oak Park is in Cicero township, Cook County, Ills., and is on the Des Plaines river (also the Chicago and Northwestern Railroad) at a point 8½ miles west of Chicago. Population, about 4,500.

THE AMERICAN GAS IMPROVEMENT COMPANY.—This Company has plenty of business on hand, and more coming in. We note that plants on the McKay-Critchlow system have been recently completed and put in operation at Sharon, Pa.; Fostoria, Ohio; and Fort Scott, Kansas, while Tiffin and Wellsville, Ohio, are now being equipped on the same plan.

ORLANDO, Florida, is now lighted by gas, and the residents are happy.

A NEWSY LETTER FROM BRO. DUNBAR.—Supt. J. W. Dunbar, of the New Albany (Ind.) Gas Light and Coke Company, writing under date of Sept. 1, says: "We have added to our gas plant, by purchase from the American Electric Manufacturing Company, a complete specimen of the electric lighting outfit supplied by that Company, and expect to have the same in perfect running order by the first of October. We purpose to supply the arc light, and have determined to operate what I might call an early and late circuit, lights on the former to be extinguished at 9:30 P.M., those on the latter to be put out at midnight. We propose to charge \$75 each per annum for the short-hour supply, the longer service to be paid for at the rate of \$100 per lamp per annum. These are to be strictly commercial lights, since it is not our intention to light the streets with electricity. We believe that all gas companies should turn their attention to the joint supply of gas and electricity, so that consumers can be supplied with whatever description of lighting agent they choose to demand. I am firmly of the opinion that a gas company can make a greater profit out of the supply of electric light than can be made by those who seek to supply it independently; and there is no doubt but that we will be able to make as large a percentage of profit from our electric business as we do from our gas business—all things taken into consideration. Our initial capacity will be that from a 50-light dynamo, but that is likely to be increased to a 100-light machine by the 1st of January, 1888. We now light 475 gas lamps on the streets of our city, for which we are paid only at the rate of \$18 per post per annum. We are obliged for that sum to keep the lamps in repair, and to light on those nights when the moon is obscured. On account of the dense foliage of our shade trees, joined to the fact that the lighting is performed at such a cheap rate, the authorities do not think it would be wisdom on their part to try electricity for street illumination. Our bills for gas supplied to ordinary consumers are made out on the basis of \$2.10 per thousand cubic feet, where the monthly consumption is in excess of 3,000 cu. ft., while those who use less than that quantity are charged \$2.35 per thousand. One year ago we charged \$2.45 and \$2.70 per thousand, and since the reduction went into effect a comparison of send-out quantities shows that so far this year we have sold 13 per cent. more gas than for same time last year. Southern Indiana has been overrun by parties engaged in the search for natural gas, but despite the activity of the drillers only surface gas, not sufficient in volume to permit of its utilization, has been obtained. In all these wells the drills have penetrated the Trenton, but results, as well as the prospects, have been most unsatisfactory. In fact the repeated failures have about convinced the prospectors that Southern Indiana is not in the 'gas belt.' About a year ago your correspondent, 'Retort,' mentioned that, at De Pauw's plate glass works, located in this city, fuel gas was to be manufactured and used for fuel purposes. He also said that the proposed new departure was attracting a great share of attention. Now, as to the final results of the glass works experiment. About \$100,000 was expended in the development of the project, but, for some reason or another, the trial ended in complete failure. At the present time the owners of the glass works are drilling on their premises, the bore-hole having already reached a depth of 2,300 feet, at which point it is thought the Trenton ought to have been reached. They will admit a failure if gas is not encountered on or before the drills sink to a depth of 3,500 feet."

SALE OF THE FLUSHING (L. I.) ELECTRIC LIGHT FRANCHISE.—Some time ago we noted that the authorities of Flushing were anxious to sell

at public auction the right to operate an electric lighting plant in that village. The original date named for holding the sale was Aug. 1, but in consequence of the absence of bidders a postponement to the first Monday of September was ordered. The second attempt resulted in a sale, although only two bidders put in an appearance; but the residents of the handsome Long Island village are quite satisfied at the figure obtained. Mr. J. H. Wilson, President of the Board of Trustees, acted as auctioneer, and after some spirited bidding the franchise was sold to Mr. E. H. Hurst, who represented an Eastern Company, it is said. He agreed to pay into the village treasury 25 per cent. of the gross earnings during each year in which the plant remained in operation. A resident of Flushing, in commenting on the terms of the bargain, said he doubted whether any company could pay such an exorbitant rental, and carry on business for any length of time.

RESTORED.—The plant of the Homer and Cortland (N. Y.) Gas Light Company, which suffered somewhat severely from damage by fire not long since, is being restored on a decidedly substantial scale. Two fire-proof buildings (constructed of stone, topped with substantial roofs) are being erected, the larger of which (124 ft. by 29 ft.) is intended to house the coal supplies, while the other (75 ft. by 25 ft.) will be devoted to coke, lime, etc., storage. Locomotive sparks will no more cause trouble to the Homer & Cortland gas men, and Bro. Wood is one of the latter.

A BRISK TRADE IN THE CONNELLY & CO. SPECIALTIES.—The Messrs. Connelly have no reason to find fault with their list of shipments for the month of August. The returns show the following sales and deliveries for the period in question: *Automatic Governors.*—One 20-inch to Grand Rapids, Mich.; one 16-inch, to St. Louis, Mo., and 2 to Dayton, O.; 12-inch to Chattanooga, Tenn.; 10-inch to Wichita, Kas.; 8-inch (1 each) to Johnstown, N. Y., Chillicothe, Ohio, and Victoria, British Columbia; and 6-inch to Beverly, Mass. *Iron Sponge.*—8,000 bushels to Equitable Company, N. Y. City; 5,000 bushels to Phila., Pa., gas works; 800 bushels to San Diego, Cal.; 100 bushels to Fostoria, Ohio; 600 bushels to Plainfield, N. J.; 75 bushels to Cadiz, Ohio, and 50 bushels to Evanston, Ill. *Gas Exhausters.*—6-inch instruments of this class were shipped to Lewisburg, Pa., Perth Amboy, N. J., and Cardenas, Cuba. A pretty well distributed trade, and all will concede that these enterprising merchants merit the success that has attended their efforts.

ANOTHER GAS THIEF.—A man named W. Spielmeyer, a resident of No. 1009 North Bond street, Baltimore, has been indicted by a grand jury of that city on a charge of violating the Maryland act intended to protect gas companies from the depredations of those who surreptitiously tap gas mains. The defendant made free with a main of the Consolidated Gas Light Company, which would seem to indicate that he is a purloiner with decidedly small ideas, for gas is pretty cheap in Baltimore just now. He gave bail for trial. Spielmeyer's knavery was discovered by one of the private detectives employed by the Baltimore detective agency of Smith, West & Lyons.

THE HALIFAX (N. S.) GAS COMPANY FAVORS THE JARVIS FURNACE.—The proprietors of the Halifax Gas Light Company, thinking that economy means money, are equipping two boilers with the Jarvis Furnace, in order that wetted coke can be used for fuel. It is claimed that thoroughly wetted coke, when consumed under boilers set with the Jarvis Furnace, which system permits of the delivery of a supply of hot air above the fire proper, insures an intense heat, the same being gained at a very low cost. Boilers set in the way above noted are now in operation at the following gas works: Charlestown and Brookline, Mass., Burlington, Vt., and Schenectady, N. Y.

ANNUAL ELECTION PROVIDENCE (R. I.) GAS COMPANY.—A Providence correspondent writes that "the stockholders of the Gas Company met at noon, Monday, Sept. 5, President A. C. Barstow occupying the chair. The President read the annual report of the Directors (it was quite brief), and the same was accepted, approved and filed. The report conveyed the information that about three miles of main pipe had been laid during the year, the total length of pipe now owned by the Company aggregating 154 miles. The price of gas had been reduced from \$1.70 to \$1.50 per thousand cubic feet, no distinction being made between the city or private consumers. The use of gas stoves and gas ranges was steadily increasing, and it seemed to be the general opinion among those who used them that gas cookers were economical in the items of time, money and convenience. When the report was disposed of, the ballot for a Board of Directors resulted in the selection of the following: Messrs. Wm. Goddard, Amos C. Barstow, Alpheus B. Slater, Royal C. Taft, Edward Bierce, Jesse Metcalf, Amos N. Beckwith, Geo. W. R. Matteson

and Lucien Sharpe. Subsequently the Directors organized by electing Amos C. Barstow, President; Wm. Goddard, Vice-President; A. B. Slater (of course) being named Secretary and Treasurer. The business of the Company is in an eminently satisfactory condition, and those in charge thereof are entitled to all possible praise." Since we completely agree with our correspondent in his final expression of opinion, we have only to respond, "Amen!"

PUBLIC LIGHTING AT PORTLAND, OREGON.—The authorities of Oregon have asked for proposals for the public lighting of that city, but have concluded to be somewhat more liberal than their original plan seemed to indicate. The initial suggestion was to the effect that the city should only ask for bids for oil lamps, but the "dark age" advocates were finally induced to grant gas and electricity a chance in the field. Of course, there would be no trouble in obtaining a plentiful supply of gas, but the electric lighting end of the proposition is involved in a pretty thick cloud of doubt. It is reported that a Mr. Hogue intends to put up an electric light plant near a large sawmill (located on Water street) owned by him, but some of the Councilmen are afraid that, should Hogue put in a bid and secure a contract for the city lighting, his plant might not be completed in time to do the work. Very nice reasoning (on the part of a Councilman), no doubt, but is it not fair to assume that Hogue knows what he is about. However, Portland is ruled by a remarkably queer collection of city fathers, and the Portland Gas Company will, we think, coincide in that opinion; but we respectfully suggest that they give Hogue a chance, for they cannot, in any event, act in the future more meanly towards him than they did with the Gas Company in the past.

TOPEKA, KAS., SIMILARLY AFFECTED.—Writing about City Councilmen, and the surprising fondness exhibited by many of them for kerosene oil, etc., as a street lighting agent, puts us in mind of a letter recently received by the JOURNAL from J. T. Clark, Secretary of the Excelsior Coke and Gas Company, of Topeka, Kansas. Our correspondent takes us to task for an inaccuracy that occurred in "Retort's" letter, published in our last issue, in which it was stated that the City Council of Topeka, after refusing to renew its contract with the Gas Company, had awarded the public lighting of the city to the Brush Electric Light Company. Accepting Secretary Clark's disclaimer and rebuke with that humility so characteristic of those who "write for the press," we herewith cheerfully (because we wish to straighten out the mistake) and sadly (because Topeka is in the hands of such unprogressive rulers) publish his concise account of just what action was taken by Topeka's City Fathers anent the public lighting contract. The Secretary says: "Our City Council have not contracted with the Brush Electric Light Company for lighting the city by the tower or any other electric system, and there is no probability that it will be done. Our City Council have, on the contrary, ordered the whole city lighted with *oil lamps*, although our Company proposed to furnish gas light, fully equal in quality to the best in use in any city of the country, at a *less cost* than is paid for the common oil lamps. Surely our Council must have imagined themselves back in the dark ages, and were fearful too much light might hurt their eyes." Could it be, Mr. Secretary, that the Councilmen, instead of being fearful about having their eyes dazzled, were actuated by reasons which might have affected their personal pockets? If such a consummation were reached in this section of the country, a grand jury might be called upon to take a look over the proceedings that led to the adoption of a contract contrary in every sense to the efficient and cheap service of those whom it was intended to benefit.

OFFERING TO LEASE THE WORKS.—It is reported that a proposition to lease that plant has been made to the proprietors of the Lebanon (Pa.) Gas Company. The proposers offer to take the works for 99 years at a rental of 10 per cent. on the capital stock (\$70,000), with the option of buying out the Company at any time within the first 10 years of the life of the leasehold, for the sum of \$100,000. One reason advanced in favor of the lease, by those who are anxious to secure it, is that the electric light is likely to seriously interfere with the Lebanon gas supply. But, if so, would not that fact equally interfere with the prosperity of those who are now negotiating for the property?

THE GLEASON COMPANY CONTROLS THE SALE OF THE GREGORY BURNERS.—Mr. George H. Gregory, patentee and former manufacturer of the "Retort" and "Incandescent" gas burner specialties, has given notice to the trade that the Gleason Manufacturing Company has purchased the exclusive right to manufacture and sell the burners and lamps protected by patents issued to Mr. Gregory on Oct. 31, 1882, and May 31, 1887.

SOMETHING MORE ABOUT THE PETITION FOR THE TOWN OF LAKE GAS FRANCHISE.—Elsewhere we note that a petition had been made to the Board of Trustees, of Lake, Ills., for the right to operate a gas works in the locality named. Later advices state that Mr. C. E. Judson, President of the Lake Gas Company, forwarded a letter to the Trustees in which he called attention to the fact that by an ordinance previously granted to the Northwestern Gas Company the exclusive right to lay gas mains within Lake township was granted to the incorporators of that Company for a period of 30 years. President Judson says that his Company would insist upon that right, and if the Board intended granting any other Company a right which would interfere with the present Company, or the exclusive right granted it, legal proceedings would be instituted. The letter was referred to a committee, the members whereof recommended that it be placed on file. President Sherwood, of the Economic (opposition) Light and Heat Company was present and addressed the Board on the subject, stating that himself and associates intended to furnish a good gas at much cheaper rates than those charged by President Judson's Company. He (Sherwood) said if the Board granted the ordinance asked for a bond indemnifying the town against the results of any suit for damages that might be brought would be entered into. And thus the matter stands.

ANOTHER OPPOSITION COMPANY.—Articles incorporating the Zenith Gas and Water Company, of Duluth, Minnesota, have been filed. The capital stock is placed at \$500,000; those comprising the initial Board of Directors are Messrs. Prosper L. Knappen, D. Pineo, H. H. Bell, A. J. Whiteman, G. G. Hartley, R. C. Mitchell and C. M. Parkhurst; and it is proposed to manufacture gas under the system for which patents have been granted to T. G. Hall.

BRO. CRESSLER KEEPS IT UP.—The Kerr Murray Manufacturing Company, of Fort Wayne, Ind., report that their latest contracts include the following: Single lift holder, 50 ft. in diameter by 20 ft. in depth, for the Saginaw (Mich.) Gas Light Company; 2 benches of 6's, to be fired with improved furnaces, for the Fuel Gas and Electric Engineering Company, Pittsburg, Pa.; 4 benches of 6's, fitted with the "Doty" anti-seal dip and bridge pipes, for the Memphis (Tenn.) Gas Light Company; extension to the Chattanooga (Tenn.) Gas Light Company's plant, consisting of 4 annular frictional condensers, 36 ft. in diameter by 24 ft. in height; 1 tower washer, 7 ft. in diameter by 25 ft. in height; 1 set of purifiers, 20 ft. by 20 ft., and 5 ft. in depth, with 16-inch center seal and connections and hydraulic lifting apparatus for operating covers to boxes.

GOING AHEAD AT WICHITA, KANSAS.—The proprietors of the Wichita Gas, Electric Light and Power Company are progressing steadily. A wideawake correspondent in that bustling city informs us that the gas plant is being put in fine condition for the winter's calls upon it, the improvements embracing 3 benches (additional) of 6's and a double lift (62 ft. in diameter) holder. He adds: "Despite the fact that 400 are electric lights are in duty, the Company confidently expects this winter to treble the quantity of gas that was sent out in the corresponding season of a twelvemonth ago." The main system has been extended through 5 miles of new gas territory. The Wichita men are going ahead.

NEGOTIATING.—We understand that it is quite probable that Mr. M. McMillin, present lessee of the Marietta (Ohio) gas works is about to dispose of the property.

DOES IT MEAN A WAR OF RATES?—In our last we published a new schedule of rates promulgated by the old Poughkeepsie (N. Y.) Gas Light Company. Shortly after came an announcement from those interested in the management of the Citizens' Gas Light Company (same city) that from and after first inst. the following rates would prevail:

Quarterly Consumption.	Rate per M.
Less than 4,000 cu. ft.	\$1.75
Over 4,000 but under 7,000 cu. ft.	1.50
" 7,000 " " 10,000 "	1.25
" 10,000 " " " "	1.00

Ten per cent. to be added to the face of bills remaining unpaid 10 days from date of presentation. The Citizens Company's schedule being lower than that advertised by the Poughkeepsie Company, the latter immediately conformed its rates to those instituted by its rival. All of which seems to indicate that Poughkeepsie is to have another war of gas rates.

NEW GAS COMPANY.—This Los Guilicos (Cal.) Water, Light and Improvement Company has been incorporated, with the right to supply both gas and electricity. The capital stock is \$250,000, and Messrs. J. M. Donahue, N. W. Griswold, A. S. Rhorer, W. J. J. Matthews and H. N. Bird are the interested parties.

ELECTRIC LIGHT AT LOUISVILLE, KY.—The Louisville offshoot of the United States Electric Light Company is engaged in a desperate attempt to popularize incandescent electric lighting in that city. We understand that 16-candle power lamps have been offered to the residents at as low a rate as 75 cents each per month. Who can figure out a profit to the suppliers thereof on that basis of working?

Western Waifs.

BY DIAPHRAGM.

THE outlook for business throughout the territory that I visited during the fortnight looks most promising, and gas men are more hopeful about a gratifying increase during the coming year. In the language of the day, this is as it should be.

THE ever-popular Cosgrove, of Evanston, Ill., is busy putting down 3,000 feet of 10-inch main, that addition being found necessary to meet the increasing gas demands of his growing city. Additional improvements comprise a new 40-horse power boiler, an 18 by 4 scrubber and a bench of 3's.

SUPERINTENDENT Wright, of La Porte, Ind., has reported for duty after enjoying a well-deserved and pleasantly-spent month's vacation at Newport. Quite an addition is being made to the retort-house capacity at La Porte.

THE gratifying increase in consumption at South Bend, Ind., this summer is to be traced to Supt. Perkins' successful introduction of a large number of gas stoves.

SUPT. Raynor, of Adrian, Mich., who wears a pleasant smile, says: "Business has been very good, and prospects are excellent. We are putting in a new setting of 5's."

AT Elkhart, Ind., Supt. Murdock is busily engaged in altering the plant from a 6 to an 8-inch one. When the season's work will have been finished his main system will be larger, for he has put down 2 miles of 3-inch pipes, and is to bury some 4-inch lines. These extensions were absolutely necessary, because of the material growth of the city. In his dual capacity as the "gas and water man," Bro. Murdock, like the proverbial bee, is "kept humming."

OVER a mile of 4-inch pipe is necessary to reach the paper mills to the south of Niles, Mich., but Supt. Kirkham says it will be put down at once.

THE old retort house at Fort Wayne, Ind., is being raised 4 feet and is to be covered with an iron roof. To take care of the unexpected increase in the demand for more gas, new arches have been erected, and 4 benches of 6's have been placed therein. J. M. Wood is the gentleman who succeeded C. S. Knight as Superintendent.

AFTER several years of unceasing labor, Supt. G. A. Hyde, jr., of East Saginaw, Mich., has a model works, in which he justly takes great pride. This summer he found time to work up the gas stove business, and made marvellous progress at the work. Two new settings of 5's are being put in, a new forge and blower are recent additions, while a new and well-built dock (65 by 130), to facilitate the handling of coal, has just been completed. The writer has occasion to visit numerous gas works, and, for a demonstration of the theory that "cleanliness is next to cheap gas," Mr. Hyde wins the laurels.

SUPT. W. W. Prichard, of Ironton, O., is back at his post, after a lively skirmish with erysipelas. A new setting of 4's has been put in at the Ironton works, and Mr. P. announces that he is now ready for the fall campaign.

NOTWITHSTANDING the decided opposition of the local electric lighting companies, the Bay City (Mich.) Gas Light Company seems to thrive under Supt. Calhoun's conservative management. He will place 2,000 feet of 3-inch pipe this month, and erect 2 new settings (one of 5's, the other of 3's), which goes to prove the residents of Bay City are appreciative people. Mr. Calhoun hopes to announce a reduction in price shortly.

CHAS. NEUENDORF is the new Secretary and Superintendent of the Saginaw City (Mich.) Gas Light Company, vice N. Cameron. The Kerr-Murray folks have almost completed a new 50 by 20 holder for this Company. Extensive improvements are to be made next season.

THE Parker-Russell folks are setting 3 new benches of 5's for the Lima (Ohio) Gas Company. The furnaces are arranged to consume oil for fuel.

THE new (350,000 cub. ft. capacity) telescopic holder for the Grand Rapids (Mich.) Gas Light Company is nearly completed. The recent reduction in prices (noted in last issue of JOURNAL) will be the more appreciated by consumers when it is considered that the same was voluntary—no outside influence figuring as a factor in the action taken.



A. M. CALLENDER & CO.,
PROPRIETORS.

Editor—JOS. R. THOMAS, C.E.
Asst. Editor—T. J. CUNNINGHAM.
Manager—C. E. SANDERSON.

PUBLISHED ON THE 2ND AND 16TH OF EACH MONTH
At No. 42 Pine Street, New York.

This is a recognized official organ of—
LIGHT, HEAT, STEAM, WATER-SUPPLY,
VENTILATION, SANITARY IMPROVEMENT,
AND GENERAL SCIENCE.

TERMS

SUBSCRIPTION—Three Dollars per annum, in advance.

AGENTS

NEW YORK—AMERICAN NEWS Co. 39 and 41 Chambers St.
BOSTON—S. M. PETTINGILL & Co., 6 State Street.
PHILADELPHIA—PRATT & Co., Corner 9th and Arch Streets.
England—C. W. HASTINGS, 22 Buckingham St., London, W.C.
Germany—B. WESTERMANN & Co., of New York

FRIDAY, SEPT. 16, 1887.

Hints to Gas Managers.

Mr. Geo. Anderson, C.E., writing to the *Gas World*, believes that the following "hints" afford the outlines of a plan which, if carefully followed, will assist the prudent gas manager greatly in the conduct of his business:

1. Get pulling down for repairs done at odd times when hands can be spared, rather than employ extra labor, and don't employ skilled labor on it except where necessary.
2. The above especially applies to retorts. Cause all old bricks, whole or broken, to be cleaned and rebuilt, especially in parts of the work where heat is not intense—such as in bottom of ashpits, filling in front round retorts, extreme back end of oven, top flues, and the like.
3. Old bolts and washers keep in a state of repair and use up before going to stock for new ones—same applies to pieces of service pipes, old cocks, etc.
4. Keep good heats, tight retorts and lids, coals dry, charge evenly spread, and as heavy as can be fairly burned off, and always backed in from the front so that no part of the charge is nearer than 18 inches from front of mouth piece, and no leakages on any part of the works, especially in the retort house.
5. Never clinker after but always before the charge, nor let the fuel in the furnace get so low as to have holes through it.
6. Return as much as possible of pan breeze to fuel, and only breeze and clinkers to be sent out to yard.
7. Never charge all the retorts in a setting at the one draw, but rather one or two in each of several settings, thus better maintaining a good heat.
8. Never let carbon gather on the back end of a retort nor on any other part over an inch in thickness, but scurf when it is needed whenever you have retorts to spare, which may be at least every Monday, and don't scurf with an

open retort, but insert a piece of cast-iron pipe through a hole in an old lid; lute up at front and take off bonnet at top of ascension pipe to cause a circulation of air through the retort, which will clean out the pipe; and remove the lid from time to time, and with a sharp bar some of the scale may be removed, and let the first, or it may be also the second charge after scurfing, be of breeze and tar, or till the retort is tight. This you can observe at the chimney top. There never should be smoke at any chimney top, but especially at the chimney of a gas works where smokeless fuel is mostly used—therefore smoke at the chimney top is a loss to you and to me, and it is both your duty and your interest to inquire into and remove the cause of it.

9. I presume that you observe, as you pass every morning, the condition of the various pressure gauges over the works and note any change, and are never caught by pipes being so stopped as to cause gas to burst through the apparatus, and perhaps require make of gas to be stopped till pipes are cleared out. Such a manager may be compared to a traveler who, in broad daylight, walks plump into a deep hole while there is a finger-post telling him to avoid it.

10. Keep your charges as evenly spread over time as possible, so that make of gas may be nearly uniform at all times. By this your manufacturing plant, condensers, exhausters, washers, scrubbers, purifiers and station meter will do their work better, and more of it in a given time, than if the make of gas is irregular from hour to hour.

11. Always know the hours at which charges should be on, and, if you are near, give a look as you pass; you may be able to detect things that escape the notice of the men.

12. Don't allow retort lids to be exploded; it shakes the retorts and annoys the neighborhood.

13. As far as your apparatus is capable, remove every trace of ammonia from the gas before it enters the purifiers; therefore, inspect the action of your washers and scrubbers.

14. Fill lime purifiers as full as they will hold of lime, as wet as it can be made (while retaining its shape, and not falling into mortar); don't hesitate, though the layer on a tray be 12 inches thick; lime to be newly slaked, but cool, and don't fear lime thus wet giving much pressure—the wetter it is the less pressure it gives (always providing it does not cake into mortar), and the more work it will do, and have the least odor when taken out.

15. Lime purifiers need not be changed till you find carbonic acid at the middle of the last lime purifier when you have oxide ones to follow. Never allow carbonic acid to be in your purified gas.

16. In filling oxide purifiers, leave at least an inch of space between each layer, or, say, 12 to 15 per cent. of empty space, as it swells as it absorbs sulphur from the gas.

17. You will find the oxide to do more duty if you let about 1½ per cent. of air pass in with the gas, but this must be regulated so as, on no account, to injure the gas.

18. Keep your gas as uniform in illuminating power as is possible, and always over the standard. You will have fewer complaints with uniform 14-candle gas than with gas that varies from 14 to 18 candles—it is the differences that most people notice. The same applies to pressure of supply.

19. Test the day consumption by the meter provided for that purpose, at least once a week, always at the same hour and at same pressure. Such an observation has led us to look for a leak, and discover a broken main which otherwise might not have been discovered till much gas had been lost.

20. Have meter indices read at the fixed periods that your accounts may compare with the corresponding periods, and you will save yourself much trouble with customers. For the same reason, the water line of meters should be kept uniform by frequent inspection.

21. Do all you can to instruct consumers in the right use of gas—good burners, staunch pipes—so that they may get the full value of the gas. Thus you will extend its use.

22. Should your advice be received with suspicion—even should you receive a brusque reception from some—never mind that, but consider that out of hundreds of customers there will always be some who are laboring under some malady of mind or body that has upset them, and put it down to that, and never lose your temper.

23. Conduct your business so as to never require to make an apology. Stick to your colors, and always behave like a gentleman.

In New Quarters.

As intimated in a former issue, the principal offices of the American Water Works and Guarantee Company (which Company, among other ventures, controls the gas works at Muncie and Marion, Ind., Galion, Ohio, and Braddock, Pa.) are now located in the premises known as the "English Block," Pittsburgh, Pa. We are also informed that Mr. A. B. Stannard is no longer in the Company's employ.

The Market for Gas Securities.

The local market for gas securities is absolutely featureless, although average quotations for the fortnight show that the bears were not so pronounced in their hostility to Consolidated shares. While dullness is the ruling factor, and the brokers are loudly complaining thereof, it is quite likely that October is to be a busy month, for some inquiry has been made by out-of-town parties for certain New York and Brooklyn gas specialties. To-day (noon, Sept. 14) Consolidated is quoted at 73 to 74, but no large lot could be purchased, in our opinion, at a lower figure than 75. Mutual gas is more firmly held—it shows an advance of something like 3 points for the fortnight—and we incline to the view that Mutual will shortly be considered cheap at 105. Brooklyn shares have been neglected, but beyond doubt are cheap at ruling figures—that comment being especially trustworthy in connection with Williamsburgh and Nassau.

The out-of-town situation is also enveloped in lethargy; but holders seem in no way disposed to seek for a market. A bulletin (dated Sept. 12) from the publishers of the Boston "News Bureau" states that the "Bay State gas syndicate seems no nearer gaining control than several months ago. The extension of the Bay State system, however, goes on rapidly, and its large pipe will reach Chester Park in a few days. Boston gas people claim no figures have been mentioned. They have put the matter in the hands of a committee, with instructions not to consider any offer under \$1,200 per share." Cincinnati gas is a trifle weaker, while Consolidated of Baltimore has advanced.

Gas Stocks.

Quotations by Geo. W. Close, Broker and Dealer in Gas Stocks.

16 WALL ST., NEW YORK CITY.

SEPTEMBER 16.

Table of gas stock quotations including Consolidated, Central, Equitable, Harlem, Metropolitan, Mutual, Municipal, Northern, Yonkers, Richmond Co., S. I., Gas Co's of Brooklyn, Citizens, Fulton Municipal, Peoples, Nassau, Williamsburgh, Out of Town Gas Companies, Buffalo Mutual, Citizens, Newark, Chicago Gas Trust, Cincinnati G. & C. Co., Consolidated, Balt., Chesapeake, Consumers Toronto.

Advertisers Index.

Table of advertiser index listing names and page numbers under categories: GAS ENGINEERS, GAS WORKS APPARATUS AND CONSTRUCTION, PROCESSES, GAS AND WATER PIPES.

GAS ENGINES.

Table listing gas engine manufacturers and prices: Schleicher, Schumm & Co., Clerk Gas Engine Co.

RETORTS AND FIRE BRICK.

Table listing retort and fire brick manufacturers and prices: J. H. Gantler & Co., B. Kreisler & Sons, Adam Weber, Laclede Fire Brick Works, Brooklyn Retort and Fire Brick Works, Borgner & O'Brien, James Gardner, Jr., Henry Manner & Son, Chicago Retort and Fire Brick Works, Baltimore Retort and Fire Brick Co., Oakhill Gas Retort and Fire Brick Co., Evens & Howard, Cincinnati Gas Retort and Fire Brick Works, Emul Lenz.

SCRUBBERS AND CONDENSERS.

Table listing scrubbers and condensers: G. Shepard Page, R. D. Wood & Co.

REGENERATIVE FURNACES.

Table listing regenerative furnaces: Bartlett, Hayward & Co., Fred. Bredel.

GAS GOVERNORS.

Table listing gas governors: T. C. Hopper, Connelly & Co.

CEMENTS.

Table listing cements: C. L. Gerould.

GAS ENRICHERS.

Table listing gas enrichers: Standard Oil Co.

GAS METERS.

Table listing gas meters: Harris, Griffin & Co., American Meter Co., The Goodwin Gas Stove and Meter Co., Hehne & Mellhenny, D. McDonald & Co., Nathaniel Tufts.

EXHAUSTERS.

Table listing exhausters: P. H. & F. M. Roots, Smith & Sayre Manufacturing Co., Wilbraham Bros., Connelly & Co.

GAS COALS.

Table listing gas coals: Penn Gas Coal Co., Perkins & Co., Newburgh Orrel Coal Co., Despard Coal Co., Chesapeake and Ohio R.R. Coal Agency, Westmoreland Coal Company, Monongahela & Peters Creek Gas Coal Co.

CANNEL COALS.

Table listing cannel coals: Perkins & Co., J. & W. Wood.

VALVES.

Table listing valves: Ludlow Valve Manufacturing Co., John McLean, Chapman Valve Manufacturing Co., R. D. Wood & Co., The Combination Gas Machine Co.

ENGINES AND BOILERS.

Table listing engines and boilers: Jarvis Engineering Co.

PURIFYING MATERIAL.

Table listing purifying material: S. H. Douglas, Connelly & Co.

GAS LAMPS.

Table listing gas lamps: The Siemens-Lungren Co., G. Shepard Page, Albo-Carbon Light Co., Standard Gas Lamp Co.

PURIFIER SCREENS.

Table listing purifier screens: John Cabot, Geo. A. Mills.

GAS STOVES.

Table listing gas stoves: American Meter Co., The Goodwin Gas Stove and Meter Co., The Combination Gas Machine Co.

STREET LAMPS.

Table listing street lamps: J. G. Miner, Bartlett Street Lamp Mfg Co.

BURNERS.

Table listing burners: C. A. Gefroter.

STEAM BLOWER FOR BURNING BREASE.

Table listing steam blower: H. E. Parson.

GASHOLDER TANKS.

Table listing gasholder tanks: W. C. Whyte.

GAS FIXTURES.

Table listing gas fixtures: Mitchell, Vance & Co.

COKE CRUSHER.

Table listing coke crusher: C. M. Keller.

GAS BAGS.

Table listing gas bags: Peerless Manuf'g Co.

ELECTRICAL APPARATUS.

Table listing electrical apparatus: Waterhouse Electric & Manufg Co.

BOOKS, ETC.

Table listing books and other publications: English Journal of Gas Lighting, Gas as a Source of Light, Heat and Power, Goodwin's Directory of Gas Light Companies, King's Treatise, Scientific Books, Management of Small Gas Works, Newbigging's Gas Manager's Handbook, Gas vs. Electricity.

ENGLISH

"Journal of Gas Lighting."

Issued weekly. New volume commences Jan. 1, 1887. Price, \$7 per annum. Subscriptions taken by

CHARLES NETTLETON, Agent for U. S., No. 115 BROADWAY, N. Y. CITY.

THE GLOBE STREET LAMP.



MINER'S PATENT STREET LAMPS.

Are adapted for use of Streets, Parks, Depots, Ferries, & Private Grounds.

WITH POSTS OR BRACKETS.

Jacob G. Miner,

No. 823 Eagle Ave., New York, N. Y.

GAS STOVES

Of Every Description, for Heating, Cooking, Laboratory, and Mechanical Purposes.

Weber Straight-Way Valves

FOR GAS, STEAM, AND WATER.

Catalogues on Application.

Correspondence Solicited.

THE COMBINATION GAS MACHINE CO., Detroit, Mich. Windsor, Ont.

163 Maiden Lane, N. Y. City.

87 Dearborn Street, Chicago, Ill.

THE ALBO-CARBON LIGHT.

THIS SYSTEM HAS SHOWN ITSELF IN THOUSANDS OF CASES—IN HALLS, CHURCHES, PICTURE GALLERIES, CONCERT HALLS, RESTAURANTS, BANKS, CLUBS, STORES, OFFICES, and PRIVATE RESIDENCES—TO BE THE

Best Adapted and Most Successful Method of Gas Lighting Ever Offered.

The SOFTNESS AND PURITY OF THE LIGHT make it most desirable for Office and Household Uses. Its BRILLIANCY and POWER render it unrivaled for lighting Halls, Churches, etc. Its ECONOMY secures for it general favor wherever used.

NOTICE.—Suits are pending in the United States Circuit Courts in Illinois and Pennsylvania against various parties for infringement of our Letters Patent No. 247,925, dated October 4, 1881, and No. 333,862, dated January 5, 1886. The first of these suits has come up for hearing, and an injunction has been granted therein. The second of said suits has not yet been reached for hearing. All persons are cautioned against manufacturing, selling, or using any apparatus or material which infringes our patents. We intend to prosecute all parties infringing patents owned by us.

ALBO-CARBON LIGHT CO. (Sole Manufacturers for the United States) Main Office, Newark, N. J.

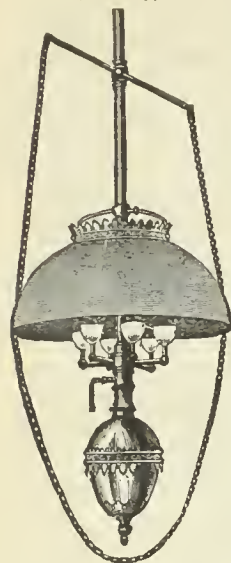

The Waterhouse System of Arc & Incandescent Lighting

Is invariably appreciated by electricians. The light produced is remarkably steady, and the regulation wonderful. The efficiency of the dynamo (closed circuit) is a large percentage in our favor as compared with that of the open circuit machines, so that we show GREAT ECONOMY.

Investigation Invited by Electrical Experts and Others.

SEND FOR CATALOGUE.

THE WATERHOUSE ELECTRIC AND MFG. COMPANY,
Factory, Colt's West Armory. Hartford, Conn.

To All Whom It May Concern!

The SIEMENS-LUNGREN COMPANY hereby warns the public against the use of various infringing Regenerative Gas Lamps which are offered for sale. This Company has heretofore delayed bringing suit to enjoin the manufacture or importation of such infringing lamps, solely because of the practical worthlessness of the infringing devices; and although, in each instance, they infringe some one or more of the various patents owned or controlled by this Company, they have fallen into disuse sooner than any suit could be brought to a hearing. As, however, the introduction of these infringing lamps has tended to discredit the practicability of our Company's system of regenerative gas lighting, we have instructed our Attorneys Messrs. Geo. Harding, C. S. Whitman, and Silas W. Pettit, to give notice that legal proceedings will in future be taken against all such infringers.

THE SIEMENS-LUNGREN CO., 21st St. & Washington Av., Phila., Pa.

Water & Gas Pipe.

RUSTLESS

Send for New Catalogue.

RUSTLESS

The WELLS RUSTLESS IRON COMPANY,
Nos. 7 and 9 Cliff Street, New York City.

GASHOLDER TANK CONSTRUCTION, ETC.

Gas Companies and others about to erect Gasholders will find it profitable to consult W. C. WHYTE, who for over thirty years has made a specialty of

Holder Tank Excavation and Mason Work.

Fifty tanks now in operation show the sort of work done. Address

W. C. WHYTE, No. 15 Cortlandt St., N. Y. City.

BOOKS.

DISTILLATION OF COAL TAR AND AMMONIACAL LIQUOR.

By GEORGE LUNGE. Price \$8.50.

A TREATISE ON THE COMPARATIVE COMMERCIAL VALUES OF GAS COALS AND CANNELS.

By DAVID A. GRAHAM. 8vo., Cloth. Price \$3.

Orders for these books may be sent to this office.

A. M. CALLENDER & CO.,

42 PINE ST., N. Y. CITY.

BARTLETT, HAYWARD & CO.

Baltimore, Md.

Munich Regenerative Furnace, System Drs. Schilling & Bunte.

Greatest durability; minimum of attention; complete distillation in $3\frac{1}{2}$ hours; 10 to 13 pounds of coke to hundred-weight of coal; no clinker; no carbonic oxide in regenerative flues.

TWO AND THREE-LIFT TELESCOPIC GASHOLDERS,

With Wrought Iron Tanks, constructed above ground, of any magnitude.

Condensers, Scrubbers, Purifiers, Bench Castings, Roofs, Boilers, Etc.

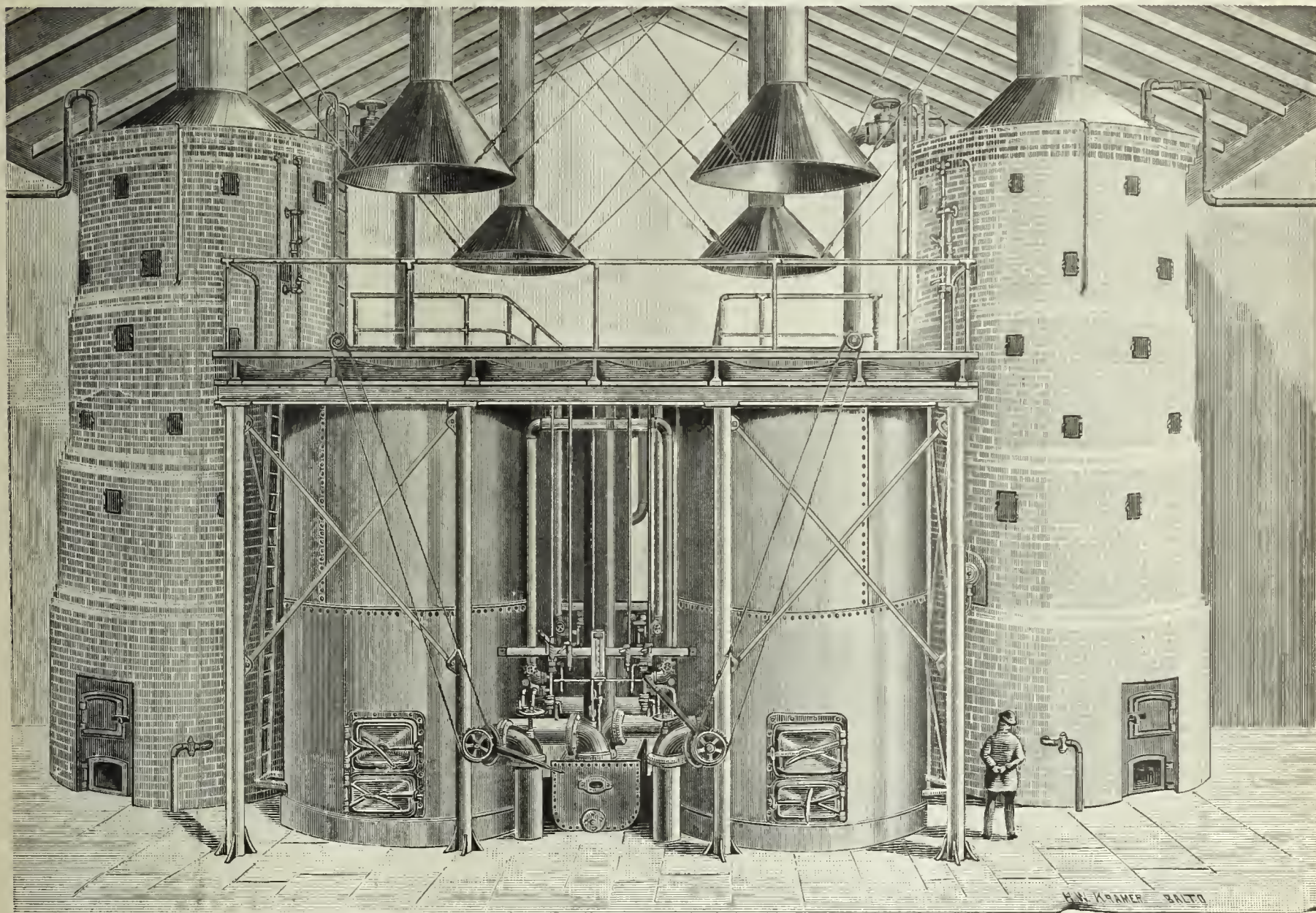

The Wilkinson Water Gas Process.

Introducing the Munich Regenerative Furnace for Coal Gas, we find on the part of many Gas Companies the desire to combine to a greater or less extent an efficient system of making high candle power Water Gas; and with a view of enabling this to be done WITHOUT EXCESSIVE CHARGES FOR PATENT RIGHTS, ETC., we have acquired, by purchase, the exclusive right to construct all the Water Gas Apparatus under the valuable "Wilkinson" Patents.

The results obtained by this Process are far better than those obtained by any other apparatus, especially where an illuminating gas of high candle power or a fuel gas of intense temperature is required.

The Process is uninterrupted, making gas of uniform quality and quantity. Its greatest advantages are maximum production with minimum material and labor, combined with great durability of apparatus.

The Process is in successful operation at the works of the N. Y. Mutual Gas Company, New York; Consolidated Gas Company, Baltimore, Md.; the Hudson County Gas Light Company, of Hoboken, N. J.; and at Rye, N. Y.

We shall be glad to give further detailed information upon application.

Sole Agents for the Celebrated Hazelton Boiler.

BARTLETT, HAYWARD & CO.

EXHAUSTERS.

EXHAUSTERS.

PROCESSES.

ROOTS' NEW GAS EXHAUSTER.

St. Louis, Mo.,
March 21, 1887.

Messrs. P. H. & F. M. Roots, Connorsville, Ind.:
Dear Sirs—In 1872 one of your No. 5 Exhausters was placed in these works, and worked satisfactorily. In March, 1885, it was replaced by one of your No. 6 Exhausters. The latter has been in almost constant use the past two years, has worked up to all my expectations, and is to-day in apparently as good condition as when first set up. It has not cost one cent for repairs in all that time. I have also

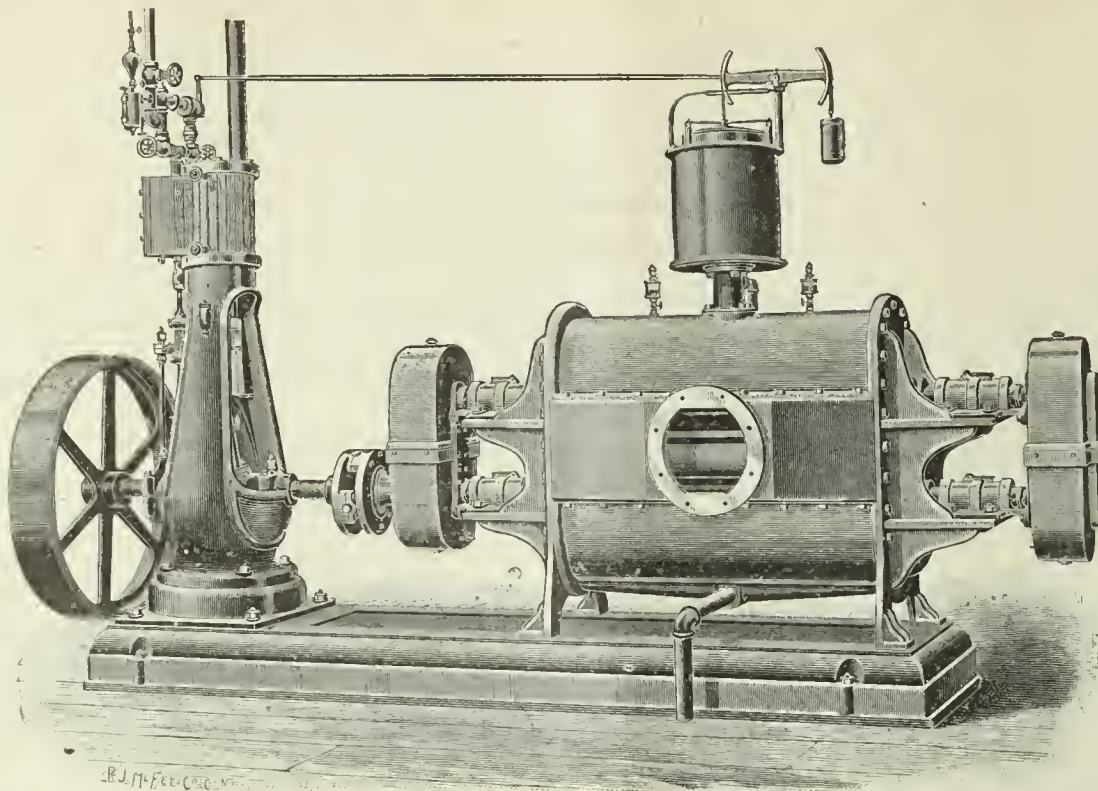

had one of your No. 1 Exhausters, with Engine on same bed-plate, fitted with your valves and Huntoon Governor, placed in a small works under my control, and in its operation it seems as near perfection as I ever expect an Exhauster to become. Without in the least disparaging Exhausters of other makes, I may say that your Exhauster may be safely recommended as unsurpassed by any other, to those requiring such machines.

Yours respectfully,
FREDERIC EGNER,
Eng. and Supt.

CONSTRUCTED ON ENTIRELY NEW PRINCIPLES.

THE ONLY EXHAUSTER MADE IN WHICH

The Internal Operating Parts Consist of Only Two Pieces, Each Cast Entire in One Piece.

Send for Descriptive Catalogue and Price List.

P. H. & F. M. ROOTS, Patentees and Manufacturers, **CONNERSVILLE, IND.**

S. S. TOWNSEND, Gen. Agt., 22 Cortlandt St., N. Y. COOKE & CO., Selling Agts., 22 Cortlandt St., N. Y.

DURING THE PAST YEAR, THE

NATIONAL GAS LIGHT AND FUEL CO.

218 LA SALLE ST., CHICAGO,

Have Erected Twelve Sets of Water Gas Generating Apparatus under the *Springer Cupola* System. They are as follows:

Newton Illuminating Company, Newton, Kansas.—Daily capacity, 120,000 cu. ft.

Wellington Light & Heat Co., Wellington, Kansas.—Daily capacity, 120,000 cu. ft.

Chippewa Falls, Gas Light Co., Chippewa Falls, Wis.—Daily capacity, 120,000 cu. ft.

Elkhart Gas Light & Coke Co., Elkhart, Indiana.—Daily capacity, 120,000 cu. ft.

Madison City Gas Light Company, Madison, Wis.—Daily capacity, 120,000 cu. ft.

South Bend Gas Light Co., South Bend, Indiana.—Daily capacity, 250,000 cu. ft.

Sheboygan National Gas Comp'y, Sheboygan, Wis.—Daily capacity, 120,000 cu. ft.

Salina Gas Light Company, Salina, Kansas.—Daily capacity, 120,000 cu. ft.

Rathbun Company, Deseronto, Province Ontario.—Daily capacity, 80,000 cu. ft.

Jefferson City Gas Light Co., Jefferson City, Mo.—Daily capacity, 120,000 cu. ft.

Mankato Gas Light Company, Mankato, Minnesota.—Daily capacity, 80,000 cu. ft.

Minneapolis Gas Lt. & Coke Co., Minneapolis, Minn.—Daily capacity, 1,000,000 cu. ft.

1886

1886

CONNELLY & CO., LTD.,

SOLE MANUFACTURERS OF THEIR PATENTED SPECIALTIES.

"IRON SPONGE." Saves money, saves labor, and is the most efficient purifying agent ever offered as a substitute for lime. Now used in every State in the Union, and purifying daily over twenty-five million cubic feet. Should be used in every gas works. Its own saving will pay for it many times over.

AUTOMATIC GOVERNOR. Has been on the market but two years, and in that time has been introduced more generally than any invention ever designed for use in gas works. Over one hundred of them now in use. Sensitive; reliable; perfectly automatic; reduces leakage; satisfies consumers, and gives great relief to the Manager. No gas works is complete without one of these machines.

STEAM JET EXHAUSTER. Designed particularly for small works. Combines Exhaust Tube, Steam Governor, Gas Compensator, and Bye-Pass Valves in the most compact form possible; occupies but little space; uses very little steam; operated by ordinary workmen; saves formation of carbon in retorts; increases yield 10 to 15 per cent. Specially adapted for mixing air with oil gas. No works too small to use them profitably.

Prices given on all our specialties delivered at any point in the United States. Correspondence solicited.

CONNELLY & CO., LTD., No. 177 Broadway, New York City.

WILBRAHAM GAS EXHAUSTER AND ENGINE COMBINED.

WILBRAHAM BROS., PHILADELPHIA, PA.

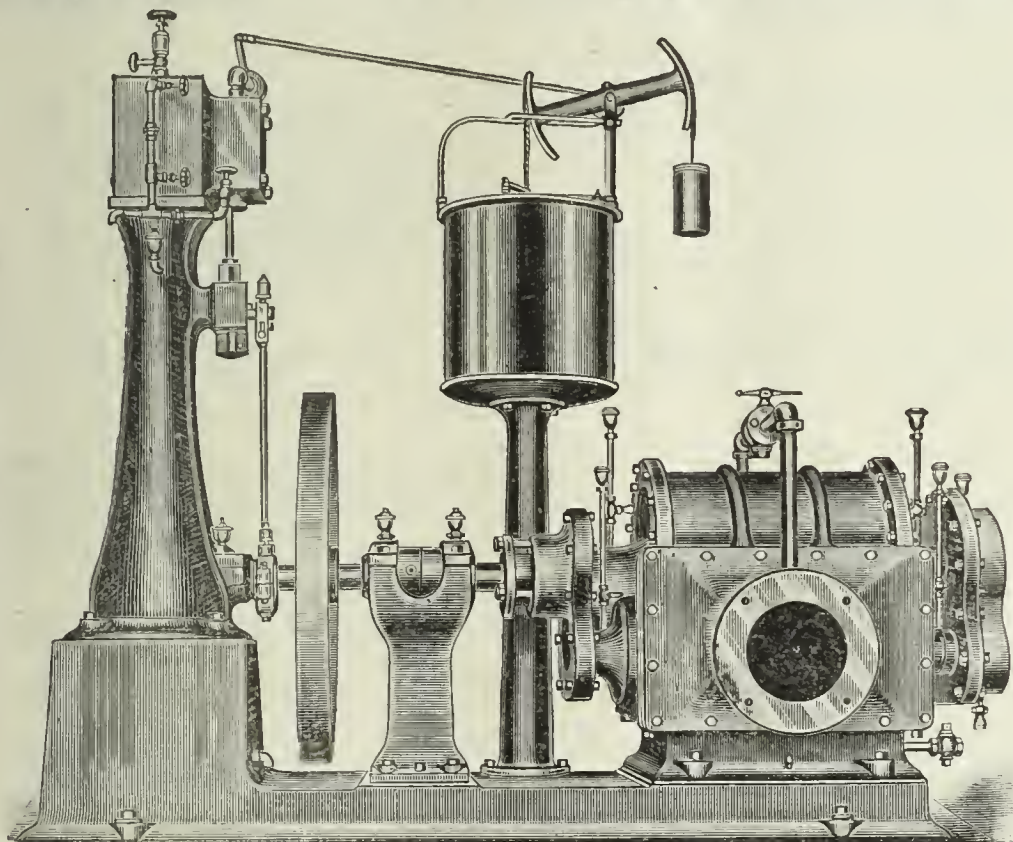

JARVIS ENGINEERING CO.,

61 Oliver St., Boston, Mass.

CONTRACTORS FOR ERECTING

COMPLETE STEAM OUTFITS FOR ELECTRIC LIGHTING STATIONS.

Steel Boilers set with Jarvis Pat. Boiler Setting

To burn **COKE SCREENINGS** for Fuel.

ARMINGTON & SIMS CO. ENGINES,

Belted direct to Dynamos, without using Shafting.

SEND FOR CIRCULARS.

REFERENCES - Charlestown Gas & Electric Light Co., Charlestown, Mass.; Schenectady Gas & Electric Light Co., Schenectady N. Y.; Brookline Gas Co., Brookline, Mass.

Improved Patent
**GAS BAG OR
BLADDER VALVE.**

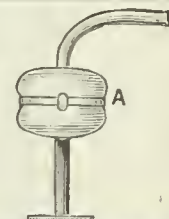

Pressure
Indicator.

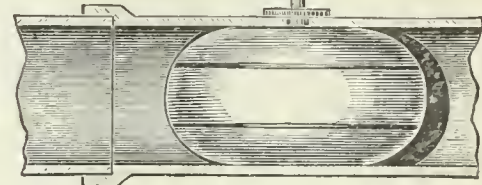

MANUFACTURED BY

PEERLESS MFG. CO., 34 Murray St., N.Y.

THE CLERK GAS ENGINE CO.,

Main Office, 1012, 1014, 1016, 1018 Filbert St., Philadelphia, Pa.

WM. W. GOODWIN, Prest.

E. STEIN, Sec.

S. LEWIS JONES, Asst. Sec.

A. J. DOTY, Supt.

The utility and convenience of the Gas Engine being no longer an open question, it only remains now for intending purchasers to select the BEST. We claim for the CLERK GAS ENGINE that it is equal to any other manufactured as regards steadiness in running, simplicity, and ease of keeping in repair, and that it gives the greatest amount of power for the least money (both in first cost and expense of running) of any engine made. In support of this claim we refer to the test of the Gas Engines made under the direction of the American Institute of New York, in December, 1885, and heretofore published in these columns. These engines are especially adapted for continuous running under heavy loads, and we can refer to Engines which have run 22 hours a day for months at a time.

Made in Sizes of 5, 10, 15, 20, and 25 Horse Power. All Engines Guaranteed for One Year.

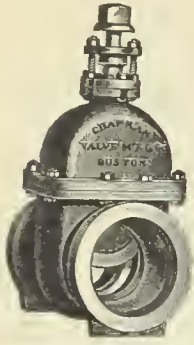

CHAPMAN VALVE MANUFACTURING CO., LUDLOW VALVE MFG. CO.

MANUFACTURERS OF

Valves and Gates for Gas, Ammonia, Water, Etc.

Also, Gate Fire Hydrants With and Without Independent Nozzle Valve. All Work Guaranteed.

WORKS & GEN'L OFFICE:
Indian Orchard, Mass.

TREASURER'S OFFICE:
72 Kilby & 112 Milk Sts, Boston, Mass.



OFFICE AND WORKS,

938 to 954 River Street and 67 to 83 Vail Av
TROY, N. Y.

How to Reduce Leakage to Its Minimum.

USE

HOPPER'S AUTOMATIC DIFFERENTIAL GAS GOVERNOR.

Needs No Attention. Simple, Reliable, Perfectly Automatic.

"Nearly Thirty in Use."

BYE-PASSES, DRY CENTER VALVES, PRESSURE REGISTERS. Also, GOVERNORS FOR STREET MAINS, *NOT DIFFERENTIAL*, and for EXHAUSTERS, GAS ENGINES, etc.

Our new Bye-Pass is threefold in its action—passes gas through, or bye-passes, or shuts off entirely. Correspondence solicited; information given. Send for circulars and testimonials.

T. C. HOPPER & CO., - - No. 2227 Wood Street, Philadelphia, Pa.

G. S. COOK, Pres. THOS. DAVENPORT (late Davenport Bros.), Sec. & Treas

BARTLETT

Street Lamp Mfg. Co.

MANUFACTURERS OF

Bartlett's Patent

GLOBE LAMPS.

FOR

Streets, Parks, Railroad Stations, Public Buildings, Etc.

LAMP POSTS A SPECIALTY.

Office and Salesroom

40 & 42 College Place, N. Y. City.

Gas Companies and others intending to erect lamps and posts will do well to communicate with us.

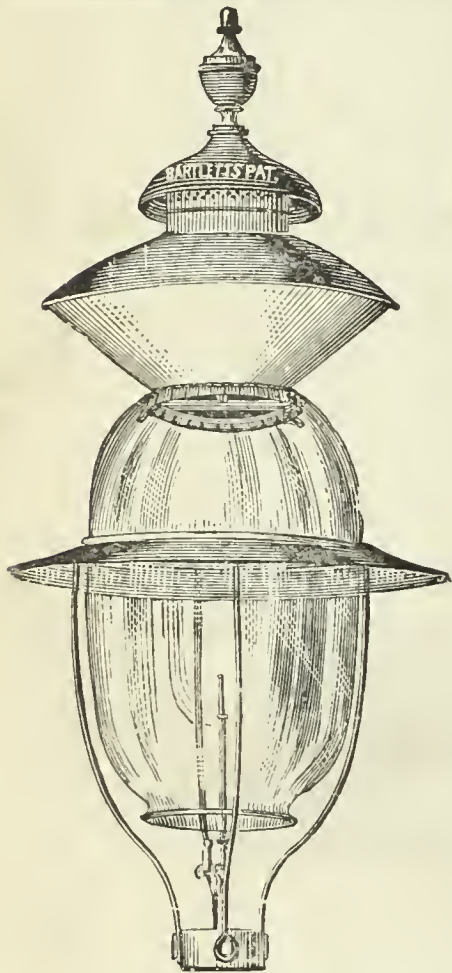

Hydraulic Main Dip Regulators, also Check Valves, Foot Valves, Yard-wash and Fire Hydrants. Send for Circulars.

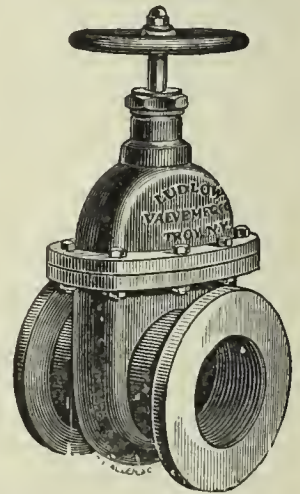

Valves.—Double and Single Gate, 1/2 in. to 48 in., outside and inside Screws. Indicator, etc., for Gas, Water, Steam, and Oil. Send for Circulars.

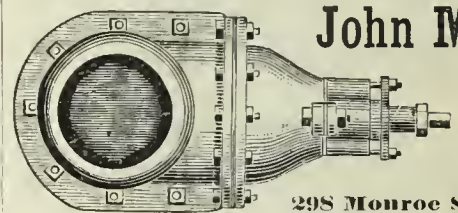

John McLean

Manufacturer of

GAS VALVES.

298 Monroe Street, N. Y.

MITCHELL, VANCE & CO.,

MANUFACTURERS OF

Chandeliers

and every description of

GAS FIXTURES.

Also manufacturers of Fine Gilt Bronzes and Marble Clocks, warranted best time-keepers. Mantel Ornaments, etc.

Salesrooms, 836 Broadway, N. Y.

Special Designs furnished for Gas Fixtures for Churches, Public Halls, Lodges, etc.

GAS AS A SOURCE OF LIGHT, HEAT, AND POWER.

By C. J. R. HUMPHREYS

A Pamphlet of twenty-nine pages, treating of the use of Gas as a source of Light, Heat, and Power.

DESIGNED FOR DISTRIBUTION BY GAS COMPANIES AMONG THEIR CUSTOMERS AND OTHERS.

Price, 10 cents each, \$5 per 100, \$50 per 1,000.

Gas Companies can have their own imprint placed on cover without extra charge. All orders to be sent to

A. M. CALLENDER & CO.,

No. 42 Pine Street, N. Y. City.

GAS METERS.

GAS METERS.

GAS METERS.

THE AMERICAN METER CO.,

MANUFACTURERS OF

WET AND DRY GAS METERS.

Extreme Simplicity in construction! More Freedom in action! Less Friction when at work! Greater Facility for Cleaning! Perfect Accuracy in Registration!

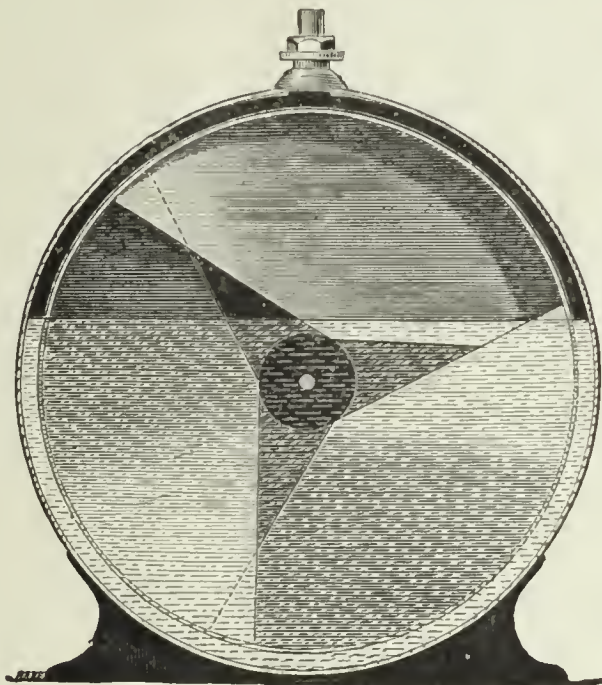

Patented May 27, 1884.

Nearly 5,000 Meters fitted with these Three-Partition Drums are in use, including Consumers' Meters, Official Standard Test Meters, and Station Meters in all sizes.

Sole Licensees in the United States for

PARKINSON'S THREE-PARTITION DRUM

For Consumers' and Station Meters.

August 22d, 1887.

Having thoroughly examined this improvement in Meter Drums, we confidently recommend their use in *Station Meters* and *Wet Meters* of smaller sizes. Among the many advantages that can be claimed for this Drum is its Increased Capacity—amounting to nearly 25 per cent. We are prepared to give estimates for new station meters or rebuilding old station meters upon this system. AMERICAN METER COMPANY.

MANUFACTORIES,

508 to 514 West Twenty-second St., N. Y.

Arch and Twenty-second St., Phila.

Nos. 244 & 246 North Wells Street, Chicago, Ill.

AGENCIES,

No. 177 Elm Street, Cincinnati, Ohio.

No. 222 Sutter Street, San Francisco, Cal.

No. 810 North Second Street, St. Louis, Mo.

GAS STOVE SHOW ROOMS, No. 223 Sixth Avenue

RETORTS AND FIRE BRICK.
J. H. GAUTIER & CO.,
 CORNER OF
GREENE AND ESSEX STREETS,
JERSEY CITY, N. J.
 MANUFACTURERS OF
Clay Gas Retorts,
Gas House Tiles,
Fire Bricks, Etc. Etc.
 Ground Clay, Fire Brick and
 Fire Sand in Barrels,
 J. H. GAUTIER. T. B. GAUTIER.
 C. E. GREGORY. C. E. GAUTIER.

BROOKLYN
Clay Retort & Fire Brick Works,
 (EDWARD D. WHITE & CO.)
 Manufacturers of Clay Retorts, Fire Brick,
 Gas House and other Tile.
 VAN DYKE, ELIZABETH, RICHARDS & PARTITION STS.
 Office, 88 Van Dyke St., Brooklyn, N. Y.

RETORTS AND FIRE BRICK.
LACLEDE FIRE BRICK MFG. CO.,
 MANUFACTURERS OF
Fire Brick, Gas Retorts,
 AND
ST. LOUIS STANDARD SEWER PIPE.
 Blast Furnace and Cupola Linings, every description of Fire
 Clay Material, Fire Clay Flue Linings, Chimney Tops
 Dry Milled and Crude Fire Clays, etc.
 OFFICE AND DEPOT
 901, 903, and 905 Pine Street,
 ST. LOUIS, MO.

ESTABLISHED IN 1845.
B. KREISCHER & SONS,
 OFFICE FOOT OF HOUSTON ST., E.R., N.Y.
Gas Retorts,
TILES, FIRE BRICK.
AND EVERYTHING IN THE FIRE CLAY LINE.

RETORTS AND FIRE BRICK.
MANHATTAN
FIRE BRICK & ENAMELLED CLAY
RETORT WORKS.
ADAM WEBER.
CLAY GAS RETORTS
AND RETORT SETTINGS
FIRE BRICKS, TILES, ETC.,
 Office and Works, 15th Street and Avenue C., N. Y.



Works,
 LOCKPORT STATION, PA. **—ESTABLISHED 1864.—**
JAMES GARDNER, JR.,
 Successor to WILLIAM GARDNER & SON.
Fire Clay Goods for Gas Works.
 CHAS. H. SPRAGUE & SON, No. 70 KILBY STREET, BOSTON, MASS., Agents for the New England States.
 Office, Rooms 19 & 20, Lewis Block,
 PITTSBURGH, PA. P. O. Box 373.

OFFICE, 418 to 422 East 23d St., New York. **ESTABLISHED 1856.** WORKS, PERTH AMBOY, NEW JERSEY.
HENRY MAURER & SON,
Excelsior Fire Brick & Clay Retort Works
CLAY GAS RETORTS, BENCH SETTINGS, FIRE BRICK, TILES, ETC.

CHICAGO
Retort & Fire Brick Works,
 OFFICE AND FACTORY,
 Clark, Forty-Fifth, and La Salle Streets,
CHICAGO, ILL.
 GEORGE C. HICKS, PRES. PAUL P. AUSTIN, SEC. & TREAS.
STANDARD
Clay Retorts and Settings.
BLOCKS & TILES
 Of every Shape and Size to Order.
Standard Fire Bricks.

GEROLD'S IMPROVED RETORT CEMENT.
 A Cement for setting on mouthpieces, and
 making... Cement is mixed ready
 of... Fully warranted
 address
LD,
 Mendota, Ill.

OAKHILL
GAS RETORT & FIRE BRICK
Works.
Proprietors,
PARKER-RUSSELL MINING & MFG. CO.
City Office, 711 Pine Street,
ST. LOUIS, MO.

Our immense establishment is now employed almost entirely in
 the manufacture of
MATERIALS FOR GAS COMPANIES.
 We have studied and perfected three important points. Our re-
 torts are made to stand changes of temperature, the strongest
 heats of the furnace, and the abrasion of feeding and emptying.
 Our customers are in almost every State of the Union, to all of
 whom we refer

THOS. SMITH, Prest. AUGUST LAMBLA, Vice-Prest. & Sup
BALTIMORE
RETORT & FIRE BRICK CO.
 MANUFACTORY AT
LOCUST POINT, BALTIMORE, MD.
 Connection with the City by Telephone.
Clay Retorts, Blocks & Tiles,
FIRE BRICK, FIRE CLAY,
AND FIRE CEMENT.

Red and Buff Ornamental Tiles and Chim-
 ney Tops. Drain and Sewer Pipe (from
 2 to 30 inches). Baker Oven Tiles
 12 x 12 x 2 and 10 x 10 x 2.
WALDO BROS., 88 WATER ST., BOSTON, MASS
 Sole Agents the New England States.

EVENS & HOWARD,
916 Market St., St. Louis. Mo.
Works, Howard Station, Mo. Pacific R.R.

Fire Brick, Gas Retorts

AND
RETORT SETTINGS.

Sewer Pipe, 3 to 24 in. diameter.
Glass Pot Clay, Ground Fire Clay, in barrels and in bulk. All kinds of Fire Clay Goods.

Cincinnati Gas Retort & Fire Brick Works.
—ESTABLISHED 1872.—

CHAS. TAYLOR,
MANUFACTURER OF
Gas Retorts, Fire Brick, and Tile.
Blast Furnace Linings, Cupola Blocks, Boiler Tiles, Grate Settings, and Stove Linings. Fire Cement, Fire Clay, Fire Sand, and all other Fire Clay Goods.

Branch Works, New Cumberland, W. Va.
GENERAL OFFICE AND WORKS,
Burns St., Cincinnati, Ohio.

EMIL LENZ,
2 & 4 Stone St., N. Y. City.
CLAY GAS RETORTS
(ENAMELED.)

Fire Brick, Blocks & Tiles.
FIRE CEMENT, RETORT ENAMEL, RETORT CEMENT, ETC., ETC.
Regenerative and Half-Regenerative Benches.
PORTLAND CEMENT.
Correspondence Respectfully Solicited.

Bouton Foundry Co.,
FOUNDERS AND MACHINISTS,
CHICAGO, ILL.

Gas Works Apparatus,
PURIFIERS, CONDENSERS,
Bench Work,
SPECIALS, LAMP POSTS,
SCRUBBERS,
Iron Roofs and Floors.

Plans and Estimates furnished for new works or extensions of old works.

PATENTS.
FRANKLIN H. HOUGH,
Solicitor of American & Foreign Patents
925 F. ST., WASHINGTON, D. C.
(NEAR U. S. PATENT OFFICE.)

Personal attention given to the preparation and prosecution of applications for Letters Patent. All business before the U. S. Patent Office attended to for moderate fees. No Agency in the United States possesses superior facilities for obtaining Patents, or for ascertaining the patentability of inventions. Copies of patents furnished for 25 cents each. Correspondence solicited.

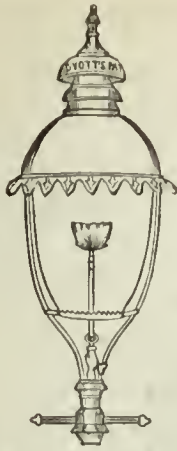

STEPHEN A. MORSE, President.
GODFREY REBMANN, Vice-Pres.

M. B. DYOTT,
Superintendent.

EDWIN F. MORSE, Secretary.
CARLTON M. WILLIAMS, Treas.

STANDARD GAS LAMP CO.,

Office, 411 Cherry St. Factory, 1101, 1103 & 1105 Frankford Av.
Philadelphia, Pa.

It is to the interest of Gas Companies and Cities to use Dyott's Patent Champion Lamps, which give double the light with the same consumption of gas, and will save 50 per cent. over others in cost of keeping in repair. Gas Companies and others intending to erect Lamps of any description will do well to communicate with us. Special Drawings furnished and Estimates given on application upon Architects', Engineers' or our Draughtsmen's Plans.

Our Patent System of Instantaneously Lighting Gas (without electricity) for R. R. Depots is unequalled. Our High Candle Power Burner is superior to the Electric Light or any other High Candle Burner. We manufacture every description of Ornamental Lamps.

KLOENNE & BREDEL
IMPROVED REGENERATIVE FURNACES.

Self-Sealing Mouthpieces & Bridge-Pipes, Retort Houses,
WASHER-SCRUBBERS
Gasholders, and Complete Gas Works.

Refers, by permission, to Mr. Eugene Vanderpool, of Newark, N. J.; Mr. E. G. Cowdery, of Milwaukee, Wis.; and Mr. Theo. Forstall, of Chicago, Ill. For further information apply to
FRED. BREDEL, 332 East 17th St., N. Y. City.

CHURCH'S REVERSIBLE TRAY

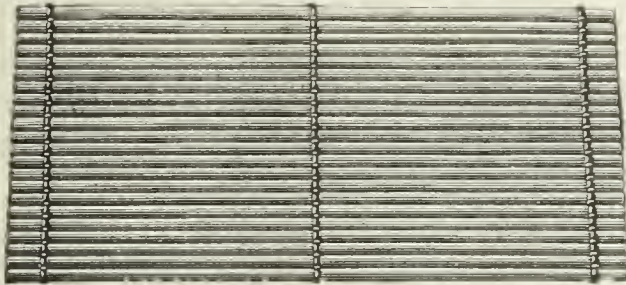

Patented July 9, 1878, and Feb. 5, 1884.
Used by the principal Companies in every State of the Union. Price List on application.

For Purifiers and Scrubbers.

OVAL OR RECTANGULAR SLATS.
FOR LIME OR IRON SPONGE.
MALLEABLE IRON CROSS BARS.

Strongest! Most Durable!
Most Easily Repaired!

MANUFACTURED BY
JOHN CABOT,
306 to 310 Eleventh Ave., N. Y. City.

MILLS' REVERSIBLE LIME TRAY,

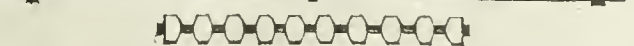

AND
WOODWORK

Of Every Description
NEEDED BY GAS WORKS.

SEND FOR CIRCULAR AND PRICE LIST TO
GEORGE A. MILLS,
Canton Av. & President St., Baltimore, Md.

Ferric Oxide for Gas Purification.

Ferric Oxide, as ground, screened, and prepared by me for purifying purposes, has now been in use for several years by many of the gas works throughout the country, including Detroit, Chicago, Milwaukee, East Saginaw, Burlington (Iowa), Ann Arbor, etc. It has proved, as I believe, the Most Effective and Economical Agent now in use. I am prepared to furnish the Oxide by the 100 lbs. or in car load lots, and will be pleased to give price f.o.b. cars at Ann Arbor or at place of destination. Address

S. H. DOUGLAS, Prest. Ann Arbor (Mich.) Gas Light Co.

GAS AND WATER PIPES.

GAS AND WATER PIPES.

ENGINEERS.

SAM'L R. SHIPLEY, Pres.
HENRY B. CHEW, Treas.

JAS. P. MICHELLON, Sec.
WM. SEXTON, Supt.

GLOUCESTER IRON WORKS,
GLOUCESTER CITY, N. J.



Cast Iron Gas & Water Pipes, Stop Valves, Fire Hydrants, Gasholders. &c.
Office No. 6 North Seventh Street, Philadelphia.

MATTHEW ADDY, President.

W. L. DAVIS, Selling Agent.

GEO. P. WILSHIRE, Sec. & Treas.

Cincinnati and Newport Iron and Pipe Company,
NEWPORT, KY.

Lamp Posts
AND
BENCH CASTINGS

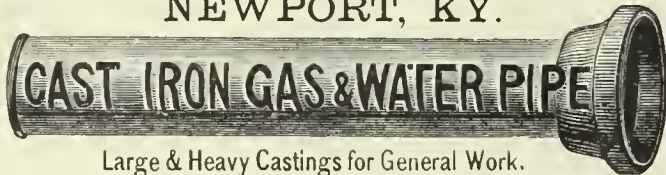

Branch
AND
SPECIAL CASTINGS

A Specialty.

Large & Heavy Castings for General Work.

FOR GAS & WATER CO'S.

Manufacture Pipe from 2 to 48 inches. All work guaranteed first quality.

Pancoast & Rogers.

WROUGHT IRON PIPE,

VALVES AND GATES,

Cast Iron Gas & Water Pipe.

28 Platt and 15 Gold St., New York.

Parson's Steam Blower,

FOR IMPROVING BAD DRAUGHT IN BOILERS, AND FOR BURNING BREEZE OR OTHER WASTE MATERIAL.

PARSON'S TAR BURNER,

FOR UTILIZING COAL TAR AS FUEL.

PARSON'S AIR JET TUBE CLEANER,

FOR CLEANING BOILER TUBES.

These devices are all first-class. They will be sent to any responsible party for trial. No sale unless satisfactory. Manufactured by the WATERTOWN STEAM BLOWER COMPANY.

H. E. PARSON. Supt., 33 & 35 Liberty St., N. Y.

The Management of Small Gas Works.

By C. J. R. HUMPHREYS. Price, \$1.

A. M. CALLENDER & CO., 42 Pine St., N. Y.

P. D. WANNER, Chairman. A. H. MELLERT, Sec. & Treas.
MELLERT FOUNDRY & MACHINE CO., Ltd.
Reading, Pa.



Specials—Flange Pipe, Valves and Hydrants, Lamp Posts, Retorts, etc.

General Foundry and Machine Work.

JOHN FOX, Selling Agent. 160 Broadway, N. Y.

THE OHIO PIPE COMPANY,

MANUFACTURERS OF

Cast Iron Gas & Water Pipe,

BRANCH AND SPECIAL CASTINGS.

Gas-House Bench Castings, Hydraulics, Lamp Posts, Flange Pipe and Specials, Architectural Castings, Building Columns, Joists, Cellar Grates, Sash Weights, etc.

GENERAL FOUNDERS AND MACHINISTS.

Columbus, Ohio.

M. J. DRUMMOND,



SPECIAL CASTINGS AND LAMP POSTS.

Equitable Building, 120 Broadway, N. Y.

JOS. R. THOMAS, C.E.,

May be Consulted on all Matters Relating to Gas Works and Gas Manufacture.

ADDRESS THIS OFFICE.

WM. MOONEY

(Successor to WM. FARMER)

27 Pearl Street, N. Y. City.

(One door from Whitehall Street.)

CONTRACTOR FOR THE ERECTION OF GAS WORKS, OR

APPARATUS OF ANY CAPACITY. AGENT FOR

WM. FARMER'S PATENTS.

Plans and Specifications Furnished.

WM. HENRY WHITE,

CONSULTING AND CONSTRUCTING

Gas Engineer & Contractor

Estimates, Plans, and Specifications furnished for new works or extensions of existing works.

No. 32 Pine Street, New York City.

Correspondence solicited.

WM. GARDNER,
Gas Engineer,

Lewis Block, Room 20, Pittsburgh, Pa.

Those who intend to make alterations in existing gas plants, or who contemplate the erection of new works, will find it to their interest to open correspondence with the above. Plans made and estimates furnished.

GAS LAMPS.

SCRUBBERS AND CONDENSERS.

The Siemens and Lungren REGENERATIVE GAS LAMPS.

A System of Burning Gas whereby its Illuminating Power is Increased from 300 to 400 per ct. without the Expense, Trouble and Annoyance resulting from the use of Hydrocarbon Enriching Material.

The Siemens-Lungren Company received the only Silver Medal or Highest Award for Gas Burners at the "Novelties" Exhibition of the Franklin Institute, held at Phila., Oct., '85.

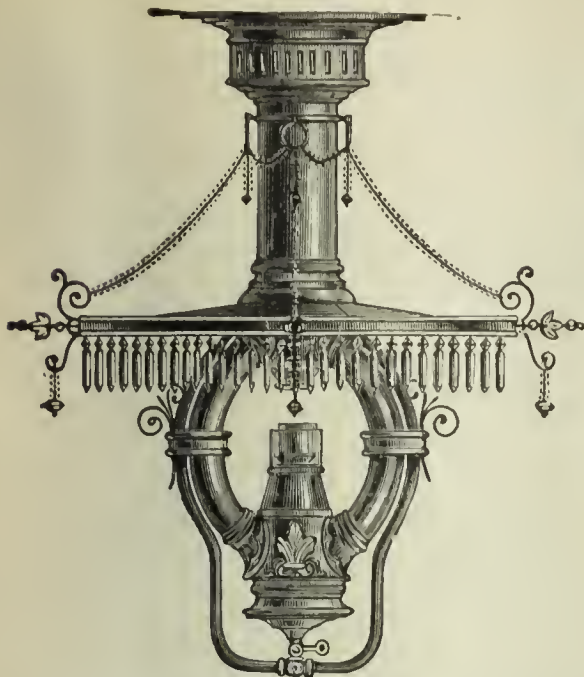

SIEMENS LAMP.



LUNGREN LAMP

THIRTEEN CANDLE POWER PER CUBIC FOOT OF GAS!

This result is obtained

SIMPLY BY THE SCIENTIFIC APPLICATION OF THE REGENERATIVE PRINCIPLE.

Consequently this largely increased illumination is always maintained without further cost and frequent attention.

THE SIEMENS-LUNCREN COMPANY,

N. E. Cor. 21st. St. and Washington Av., Phila., Pa.

KIRKHAM, HULETT & CHANDLER, Limited,
London, S. W., England.

325 PATENT "STANDARD" WASHER-SCRUBBERS,

Equal to a Daily Capacity of

288,492,500 Cu. Ft. of Gas,

Have been Supplied Throughout the World, and are

GIVING UNIVERSAL SATISFACTION!

During the present year the following Companies in the United States have ordered "Standard" Washer-Scrubbers:

Hartford, Conn.

Laclede (St. Louis, Mo.)

Lincoln, Neb.

Brooklyn, N. Y. (2)

Denver, Col.

Nassau (Brooklyn, N. Y.).

Altoona, Pa.

Lawrence, Mass.

Lynn, Mass.

GEO. SHEPARD PAGE, 69 WALL STREET, NEW YORK,

Agent for the Western Hemisphere.

GAS WORKS APPARATUS AND CONSTRUCTION.

GAS WORKS APPARATUS AND CONSTRUCTION.

WORKS: { MILLVILLE, N. J.
FLORENCE, " "
CAMDEN, " "

R. D. WOOD & CO.,

OFFICES: { 400 CHESTNUT ST.,
PHILADELPHIA.

GAST-IRON PIPE 1½ to 72 Inches in Diameter.

Water Machinery and Gas Apparatus.

HEAVY CASTINGS.

HOLDERS,

PURIFIERS,

FLOORS AND ROOFS,

LAMP POSTS,

CONDENSERS,

FLANGED PIPE,

VALVES,

BENCH WORK,

FIRE HYDRANTS,

METER CASES.

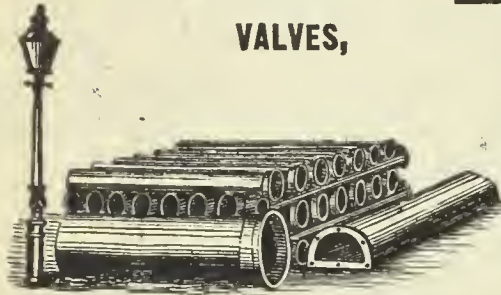

Estimates and Specifications for
NEW WORKS or EXTENSIONS
or ALTERATIONS of OLD ONES.

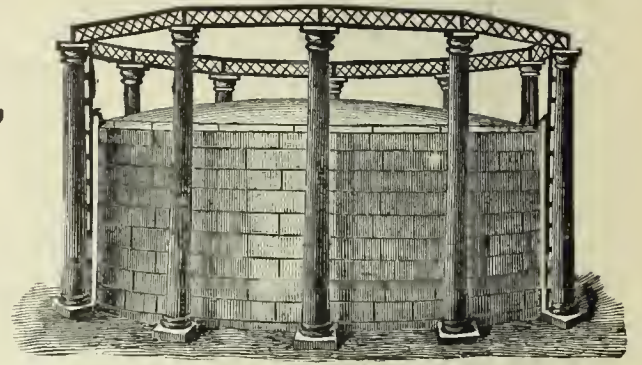

SOUTHWARK FOUNDRY AND MACHINE COMPANY,

Successors to MERRICK & SONS,

GAS APPARATUS,

Holders, Purifiers, Washers, Etc., Etc. Boiler and Tank Work. Steam Engines.
Hydraulic Machinery. Bessemer Plants, Etc.

Washington Ave. and Fifth Street, Philadelphia, Pa.

MORRIS, TASKER & CO.,

Limited,

Builders of Gas Works,

PHILADELPHIA PA.

GASHOLDERS, PURIFIERS, SCRUBBERS, CONDENSERS, EXHAUSTERS,

Bench Castings, Iron Roofs, Lamp Posts,

VALVES, STREET MAIN SPECIALS, ETC.,

MANUFACTURED BY

KERR MURRAY MANUFACTURING COMPANY.

From 1880 to 1886, inclusive, we erected Gasholders for the following cities, viz.:

Adrian, Mich.	East End Gas Co., Pitts-	Janesville, Wis.	New Castle, Pa.	Valparaiso, Ind.
Akron, Ohio.	burgh, Pa.	Johnstown, Pa.	Niagara Falls, N. Y.	Van Wert, Ohio.
Albuquerque, N. M.	East Saginaw, Mich.	Key West, Fla.	Osawatomie, Kans.	Wabash, Ind.
Altoona, Pa.	Elgin, Ills.	La Crosse, Wis.	Pittsburgh, Pa. (2)	Waco, Texas.
Anderson, Ind.	Evanston, Ills.	Lebanon, Ind.	Plainfield, Ind.	Waukesha, Wis.
Bellaire, Ohio.	Eufaula, Ala.	Lima, Ohio.	Portage City, Wis.	Wheeling, West Va.
Birmingham, Ala.	Frankfort, Ind.	Logan, Ohio.	Sedalia, Mo.	Wellington, Kans.
Bucyrus, Ohio.	Freeport, Ills.	Louisville, Ky.	Sheboygan, Wis.	West Pittsburgh, Pa.
Canton, Ohio.	Galesburg, Ills.	Mankato, Minn.	South Bend, Ind.	Xenia, Ohio.
Circleville, Ohio.	Grafton, West Va.	Mansfield, Ohio.	South Chicago, Ills.	Youngstown, Ohio.
Colorado Springs, Col.	Greensburg, Pa.	Marshalltown, Iowa.	Springfield, Ills.	Ypsilanti, Mich.
Danbury, Conn.	Huntington, Ind. (2)	Meridian, Miss.	Streator, Ills.	
Delaware, Ohio.	Ironton, Ohio.	Minneapolis, Minn.	Topeka, Kans.	
Delphos, Ohio.	Jamestown, N. Y.	Muskegon, Mich.	Uniontown, Pa.	

Under construction, 1887.

Akansas City, Kans.	Grand Forks, Dakota.	Mobile, Ala.	Santa Fe, N. M.	Fuel Gas and Electric Engi-
Dallas, Texas.	Grand Rapids, Mich.	Pittsburgh, Pa.	Wichita, Kans.	neering Co., Pittsburgh, Pa.
El Paso, Texas.	La Crosse, Wis.	Pine Bluff, Ark.	Lexington, Mo.	Stillwater, Minn.

Estimates, with Plans and Specifications, for new or the rebuilding of old works, furnished on application.
Correspondence solicited. Address

KERR MURRAY MANUFACTURING CO.,

A. D. CRESSLER, General Manager.

FORT WAYNE, IND.

GAS WORKS APPARATUS AND CONSTRUCTION.

GAS WORKS APPARATUS AND CONSTRUCTION.

JAMES R. FLOYD,
(SUCCESSOR TO HERRING & FLOYD)
Oregon Iron Works,
531 to 543 West 20th St., N. Y.
Practical Builders of Gas Works,
MANUFACTURERS OF
**ALL KINDS OF CASTINGS
AND
APPARATUS FOR GAS-WORKS.**

BENCH CASTINGS
from benches of one to six Retorts each.
**WASHERS: MULTITUBULAR AND
AIR CONDENSERS; CONDENSERS;
SCRUBBERS**
(wet and dry), and
EXHAUSTERS
for relieving Retorts from pressure.
BENDS and BRANCHES
all sizes and description.
**FLOYD'S PATENT
MALLEABLE RETORT LID.
PATENT
SELF-SEALING RETORT LIDS.
FARMER'S
PATENT BYE-PASS DIP-PIPE.
SABBATON'S PATENT
FURNACE DOOR AND FRAME.
BUTLER'S
COKE SCREENING SHOVELS.**

GAS GOVERNORS,
and everything connected with well regulated Gas Works at
low price, and in complete order.

SELLER'S CEMENT
for stopping leaks in Retorts.
N. B.—**STOP VALVES** from three to thirty inches—
at very low prices.
Plans, Specifications, and Estimates furnished.

GAS vs. ELECTRIC LIGHT.

We would invite attention to the able and exhaustive
argument of General A. Hickenlooper, President of the
Cincinnati Gas Light and Coke Company, contained in a
handsome pamphlet of 96 pages, entitled

"EDISON'S INCANDESCENT ELECTRIC LIGHTS FOR STREET
ILLUMINATION. REPORT OF AN ARGUMENT DELIV-
ERED BY A. HICKENLOOPER BEFORE THE COMMITTEE
ON LIGHT, MUNICIPAL COUNCIL, CITY OF CINCINNATI,
JULY 22, 1886."

This is a subject of special interest to all Gas Light Com-
panies.

Prices.

25 copies..... \$7.50 100 copies..... \$22.50
50 copies..... 12.50 250 copies..... 50.00

A sample copy will be sent by mail on receipt of 50 cts.
A. M. CALLENDER, & CO., 42 PINE ST., N. Y. CITY.

THE CONTINENTAL IRON WORKS.

THOS. F. ROWLAND, Prest. WARREN E. HILL and CHAS. H. CORBETT, V.-Pres. THOS. F. ROWLAND, JR., Sec. & Treas.

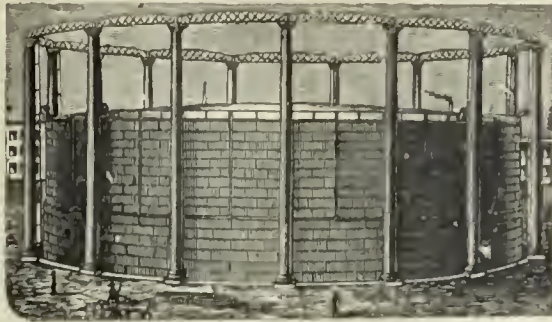

GAS HOLDERS OF ANY MAGNITUDE.

P. O. Station G., BROOKLYN, N. Y.

ENGINEERS AND MANUFACTURERS OF

Gas Holders

**CONDENSERS, SCRUBBERS, VALVES,
PURIFIERS, SELF-SEALING RETORT LIDS,
Hydraulic Mains,**

And all other articles connected with the man-
ufacture and distribution of Gas.

H. RANSHAW, Prest. & Mangr. WM. STACEY, Vice-Prest. T. H. BIRCH, Asst. Mangr. R. J. TARVIN, Sec. & Treas.

STACEY MFG. CO.,

MANUFACTURERS OF

Single and Telescopic Gasholders,

IRON ROOFS, BRIDGES, LAMP POSTS,

Water and Oil Tanks, Coal Elevator Cars,

COKE CRUSHERS, BENCH CASTINGS,

And all kinds of Wrought and Cast Iron Work used in the erection of Coal and Oil Gas Works.
Rolling Mill Machinery and Heavy Castings a Specialty.

Foundry:
33, 35, 37 & 39 Mill Street.

Wrought Iron Works:
16, 18, 20, 22, 24 & 26 Ramsey Street:

Cincinnati, Ohio.

1842. **DEILY & FOWLER,** 1887.

Laurel Iron Works.

Address, No. 39 Laurel Street, Philadelphia, Pa.

MANUFACTURERS OF

GASHOLDERS,

Single or Telescopic, with Cast or Wrought Iron Guide Frames.

Holders Built Since 1881:

- | | | | | |
|-----------------------|----------------------------|---------------------------|----------------------------|----------------------------|
| Scranton, Pa. (2d) | Holidaysburg, Pa. | Jackson, Mich. | Montgomery, Ala. | New Castle, Pa. |
| West Point, N. Y. | Galveston, Texas (2d.) | Kalamazoo, Mich. (3d.) | Newport, R. I. | Long Island City, N. Y. |
| Fitchburgh, Mass. | Marlboro, Mass. | Glen Island, N. Y. | Portland, Oregon. | Macon, Ga. |
| New London, Conn. | Denver, Col. | Warren, Ohio. | Allegheny, Pa. (2d.) | York, Pa. |
| Derby, Conn. | Chicago, Ill. (West Side). | Bath, N. Y. | Atlanta, Ga. (2d.) | Chester, Pa. |
| Bridgeport, Conn. | Pittsburgh, Pa. (S. Side) | Lynn, Mass. | N.Y. City (Central Gas Co) | Hazleton, Pa. 2d.) |
| Allegheny, Pa. (1st.) | Pawtucket, R. I. | New Bedford, Mass. | Lynchburg, Va. (2d.) | Novelties Exhbn., Phila |
| St. Hyacinth, Can. | Brookline, Mass. | Waterbury, Conn. | Saylesville, R. I. | State Island, N. Y. |
| Norwalk, O. | Sherbrooke, Can. | Deseronto, Can. | Rondout, N. Y. | Saugerties, N. Y. |
| Brattleboro, V. | Burlington, N. J. (2d.) | Hoosic Falls, N. Y. (2d.) | Atlantic City, N. J. | Clinton, Mass. (Lan. Mills |
| Waltham, Mass. (2d.) | Bridgeton, N. J. | Bethlehem, Pa. | Augusta, Ga. | Chattanooga, Tenn. |
| West Chester, Pa. | Bay City, Mich. | Atlanta, Ga. (1st.) | Waltham, Mass. (2): | Galveston, Texas. (3d.) |
| Baltimore, Md. | Erie, Pa. | Savannah, Ga. | Mahanoy City, Pa. | Omaha, Neb. |

SMITH & SAYRE MFG. COMPANY,

G. PORTER, Prest. 245 Broadway, N. Y. CHAS. W. ISBELL, Sec'y.

Machinery & Apparatus for Gas Works

Drawings, Plans, and Estimates Furnished for the Improvement, Exten-
sion, or Alteration of Gas Works, or for the
Construction of New Works.

Mackenzie's Patent Rotary and Steam Jet Gas Exhausters, Governors, Compensators,
Condensers, Washers, Scrubbers. Isbell's Patent Automatic Street Pressure Governor
Gas and Water Valves, Hydraulic Main Dip Regulator, Bench Castings, etc. Purifying
Boxes and "Standard" Scrubbers. Isbell's Patent Self-Sealing Retort Doors.

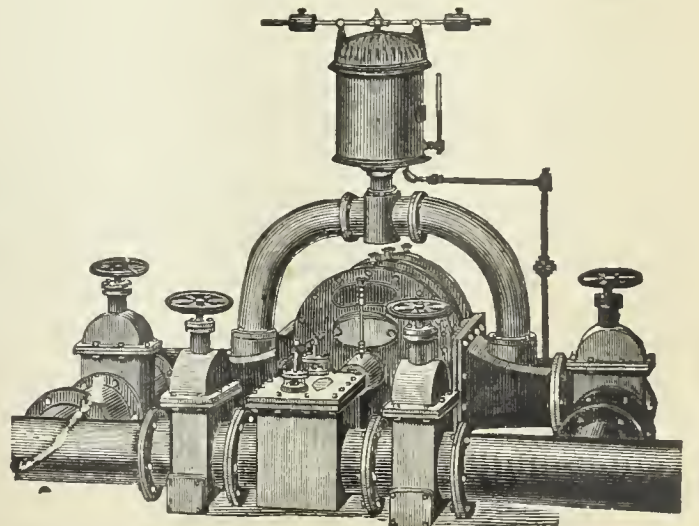

GAS COALS.

CANNEL COALS.

GAS ENRICHERS.

JAMES D. PERKINS.

PERKINS & CO.,

F. SEAVERN.

General Sales Agents for

The Youghioghenny River Coal Company's**OCEAN MINE YOUGHIOGHENY GAS COAL.**

The Coal from the Ocean Mine (recently operated by *Messrs. W. L. Scott & Co.*, of Erie, Pa.,) is now used by all the leading Gas Companies in the United States from Maine to Texas, and is recognized as *the only reliable Youghioghenny Gas Coal.* (See Map on p. 87 of this Journal, Feb. 16, '85.)

P. O. Box 3695,
New York.**PERKINS & CO., 228 and 229 N. Y. Produce Exchange.**BEAVER STREET
ENTRANCE.**BRECKENRIDGE CANNEL,
OF KENTUCKY.**

This Colliery was re-opened in June, 1886, since which date the Cannel has been delivered to over sixty of the leading Gas Companies in this country and in Europe. As an enricher ONE TON of this Cannel will do the work of TWO TONS of any other available Cannel, and is more economical than Naptha or Oil of any character. It can be delivered in parcels of one car load or more to any point in the United States or Canada.

(See AMERICAN GAS LIGHT JOURNAL, June 16, '86, pp. 346-7.)

P. O. Box 3695,
New York.**PERKINS & CO., 228 and 229 N. Y. Produce Exchange**BEAVER STREET
ENTRANCE.**JAMES & WILLIAM WOOD,****Gas and Cannel Coal Contractors,**

No. 40 St. Enoch Sq., Glasgow. No. 2 Talbot Court, London.

Proprietors of the **BATHVILLE COLLIERIES** (which produce the celebrated **BOGHEAD CANNEL**), Shields, Shieldmuir, Drumpeller, and other Collieries. This Firm offer

STANDARD CANNELS,**Unequaled as Gas Enrichers.**

Analyses, prices, and all further information furnished on application to

Agency for U.S., Room 93, Nos. 2 & 4 Stone St., N.Y. City.**The Standard Oil Company,**

REFINERS OF

NAPTHA AND GASOLINES.

ALSO MANUFACTURERS OF

**A Special Grade of Naptha for
Gas Companies****FOR ENRICHING COAL GAS.**

Correspondence solicited.

No. 43 Euclid Avenue, Cleveland, Ohio.

To Gas Companies.We make to order **CAP BURNERS** to burn any amount under a stated pressure. Send for samples.Also, **SERVICE CLEANERS, DRIP PUMPS, and STREET MAIN PROVING APPARATUS.****C. A. GEFROER,**

248 N. 8th Street, Phila., Pa.

GOODWIN'S DIRECTORY**OF THE GAS LIGHT COMPANIES of the UNITED STATES & CANADA.**Price, **\$10.00.**

Orders may be sent to

A. M. CALLENDER & CO., No. 42 Pine Street, N. Y. City.

COKE CRUSHERS.

Newburgh Orrel Coal and Coke Co.

MINERS AND SHIPPERS OF

Mountain Brook Steam and Smithing Coals,
**NEWBURGH, PALATINE,
AURORA & TYRCONNELL
GAS COALS.**

Foundry & Crushed Coke Shipped Direct from Ovens
Mines Situated at
Newburgh, Flemington & Fairmont, W.Va.

HOME OFFICE,

33 S. Gay St., Baltimore.

CHAS. MACKALL, Gen. Mangr.

CHAS. W. HAYS, Agent in New York,

Room 147, WASHINGTON BUILDING, No. 1 Broadway.

Shipping wharves at Locust Point, Baltimore.

THE DESPARD COAL COMPANY

OFFER THEIR SUPERIOR

DESPARD COAL

To Gas Light Companies and Manufacturers of Fire Clay Goods
Throughout the Country.

ROUSSEL & HICKS, } AGENTS. { BANGS & HORTON,
71 Broadway, N. Y. } 16 Kilby St., Boston.

Mines in Harrison Co., West Va. Wharves, Locust Point, Balt.

Company's Office, 15 German St., Baltimore, Md.

Among the consumers of Despard Coal we name: Manhattan
Gas Light Co., N. Y.; Metropolitan Gas Light Co., N. Y.; Jersey
City, (N. J.) Gas Light Co.; Washington (D. C.) Gas Light Co.;
Portland (Maine) Gas Light Co. Reference to them is requested.

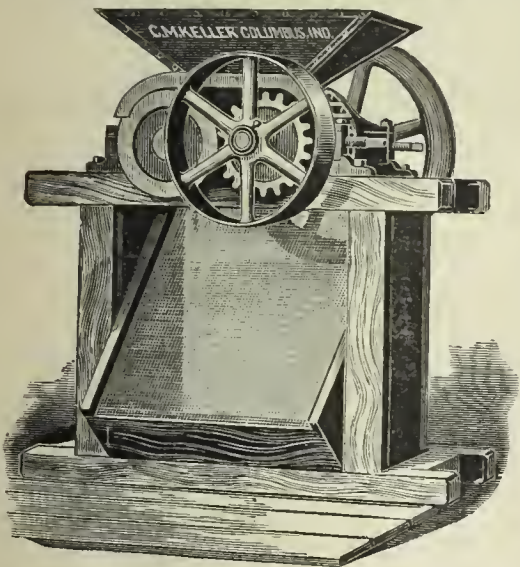

Keller's Adjustable Coke Crusher.

SIMPLE, STRONG, AND DURABLE.

C. M. Keller, Sec. & Supt. Gas Lt. & Coke Co. Columbus, Ind.

Correspondence Solicited.

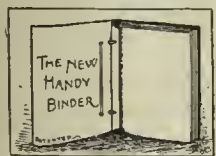

**THE NEW
HANDY BINDER.**

This article may be described as elegant
in appearance, strong, durable, and possessing many special
qualities of its own. It allows the opening of the pages per-
fectly flat, whether one or several numbers are in the binder
Any number can be taken out and replaced without disturbing
the others. The papers are not mutilated for subsequent bind-
ing in permanent form. The binder is supplied with gilt side
title, and is an ornament to any desk or reading table. The
JOURNAL, filed in the Handy Binder, becomes a volume of great
value, always convenient for instant reference. Handy Binder,
Postage paid, \$1 00.

A. M. CALLENDER & CO., 42 Pine St., N. Y.

GAS COALS.

GAS COALS.

THE
PENN GAS COAL CO.

OFFER THEIR

Coal, Carefully Screened & Prepared for Gas Purposes.

Their Property is located in the Youghiogheny Coal Basin, near Irwin and Penn Stations on the
Pennsylvania Railroad, and on the Youghiogheny River.

Principal Office:

209 SOUTH THIRD STREET, PHILA., PA.

Points of Shipment:

Pennsylvania Railroad Piers; Greenwich Wharves, Delaware
River; Pier No. 1 (Lower Side), South Amboy, N. J.

Chesapeake & Ohio Railway Coal Agency,

FOR THE SALE OF THE

**Superior Kanawha Gas Coals, Cannelton Cannel,
Also, SPLINT AND STEAM COALS,**

From the Kanawha and New River Regions, on the line of the Chesapeake & Ohio R'way.

C. B. ORCUTT, Sales Agent. | OFFICE, 150 BROADWAY, N Y

FRANCIS H. JACKSON, Prest. EDMUND H. MCCULLOUGH, V.-Prest. CHAS. F. GODSHALL, Treas. H. C. ADAMS,

THE WESTMORELAND COAL CO.

Chartered 1854.

**Mines situated on the Pennsylvania and the Baltimore
and Ohio Railroads, in Westmoreland County, Penn.**

POINTS OF SHIPMENT:

PHILADELPHIA, BALTIMORE, SOUTH AMBOY, N. J.,
WATKINS (SENECA LAKE), N. Y.

Since the commencement of operations by this Company its well-known
Coal has been largely used by the Gas Companies of New England and the
Middle States, and its character is established as having no superior in gas
giving qualities, and in freedom from sulphur and other impurities.

Principal Office, 224 South 3d St., Phila., Pa.

A. M. SCOTT, PRESIDENT. A. DEMPSTER, C.E., SECRETARY. W. K. GILLESPIE, TREASURER.

MONONGAHELA AND PETERS CREEK GAS COAL CO.,

PRODUCERS OF

Coal Bluff Gas Coal.

MINES LOCATED ON THE MONONGAHELA DIVISION OF THE PENNSYLVANIA RR.,
IN THE CENTRAL PORTION OF THE PITTSBURGH COAL FIELD.

Points of Shipment—Buffalo, Cleveland, Erie, Chicago, New Orleans.

Since the introduction of Coal Bluff Gas Coal it has taken rank among the few first-class Gas Coals, and ac-
knowledges no superior in gas-giving qualities, ease of working, quality of coke, and freedom from impurities.

Milwaukee Agents, F. R. BUELL & CO., - - - Milwaukee, Wis.

General Office, 43 Sixth Ave., Pittsburgh, Pa.

GAS METERS.

GAS METERS.

GAS METERS.



INTERNATIONAL--1876--EXHIBITION.

The U. S. Centennial Commission

HAVE DECREED AN AWARD TO

HARRIS, GRIFFIN & CO.,

Twelfth and Brown Streets, Philadelphia, Pa. No. 49 Dey Street, N. Y. City, and No. 75 North Clinton Street, Chicago, Ill.

FOR THE FOLLOWING REASONS:

The Exhibit consists of a Series of METERS from the Largest Size Station Meters for the use of the MANUFACTURE OF GAS, to those for the use of the ORDINARY CONSUMER. The Instruments are WELL MADE, RELIABLE as to INDICATION, and embody a number of sundry improvements which, with the general character of the Exhibit, entitle the whole to commendation.

Attest—J. L. CAMPBELL,
Secretary, pro-tem.

Signed—A. T. GOSHORN,
Director General

J. B. HAWLEY,
President



Dry Gas Meter.

With 39 years' experience and the best facilities for manufacturing, is enabled to furnish reliable work and answer orders promptly.

NATHANIEL TUFTS,

No. 153 Franklin Street, Boston, Mass.,

MANUFACTURER OF

DRY GAS METERS.

Station Meters of any Capacity.

Test and Experimental Meters, Pressure Registers, Pressure Gauges,
Pressure and Vacuum Gauges.

METER PROVERS, PHOTOMETERS, STREET LANTERNS, ETC., ETC.

Patent Cluster Lanterns for Street Illumination.

SCIENTIFIC BOOKS.

We are prepared to furnish to Gas Managers, and others interested in the topics treated of, the following books, at prices named:

KING'S TREATISE ON THE MANUFACTURE OF COAL GAS. Three vols.; \$10 per vol.	PRACTICAL TREATISE ON HEAT, by THOMAS BOX. Second edition. \$5.	THE GAS MANAGER IN THE LABORATORY, by a Practical Student. 8vo., Cloth. \$1.50.
GAS MANUFACTURE, by WILLIAM RICHARDS. 4to., with numerous Engravings and Plates, in Cloth binding. \$12.	GAS WORKS—THEIR ARRANGEMENT, CONSTRUCTION, PLANT, AND MACHINERY. \$8.	THE DOMESTIC USES OF COAL GAS, AS APPLIED TO LIGHTING, by W. SUGG. \$1.40.
THE GAS ANALYST'S MANUAL, by F. W. HARTLEY. \$2.50.	COAL; ITS HISTORY AND USE. by PROF. THORPE. \$3.50.	DISTILLATION OF COAL TAR AND AMMONIACAL LIQUOR by GEO. LUNGE. \$8.50.
TECHNICAL GAS ANALYSIS. \$2.80.	THE GAS WORKS OF LONDON, by COLBURN. 60 cents.	A TREATISE ON THE COMPARATIVE COMMERCIAL VALUES OF GAS COALS AND CANNELS, by D. A. GRAHAM 8vo., Cloth. \$3.
GAS MANAGER'S HANDBOOK, by THOS. NEWBIGGING. \$4.80.	THE GAS FITTER'S GUIDE, Showing the Principles and Practice of Lighting with Coal Gas, by JOHN ELDREDGE. 40 cents.	GAS AS A SOURCE OF LIGHT, HEAT, AND POWER, by C. J. R. HUMPHREYS. 10 cents.
GAS CONSUMER'S GUIDE. \$1.	GAS WORKS, AND MANUFACTURING COAL GAS, HUGHES. \$2.20.	GAS COMPANIES DIRECTORY. \$10.
A GUIDE TO GAS LIGHTING. 40 cents.	THE MANAGEMENT OF SMALL GAS WORKS, by C. J. R. HUMPHREYS. \$1.	GAS VERSUS ELECTRIC LIGHT. 50 cents.
GAS MEASUREMENT AND GAS METER TESTING, by F. W. HARTLEY. \$1.60	MANUAL FOR GAS ENGINEERING STUDENTS, by D. LEE, 40 cents.	PURIFICATION OF COAL GAS, by R. P. SPICE. 8vo. \$3.
GAS CONSUMER'S HANDBOOK, by WILLIAM RICHARDS, C.E.; 18mo., Sewed. 20 cents.	HOW TO MANAGE GAS, by F. WILKINS. Paper. 20 cents.	
A PRACTICAL TREATISE ON GAS AND VENTILATION with Special Relation to Illuminating, Heating, and Cooking by Gas, by E. E. PERKINS. \$1.25.		

The above will be forwarded by express, upon receipt of price. We take especial pains in securing and forwarding any other Works that may be desired, upon receipt of order. All remittances should be made by check, draft, or post office money order.

A. M. CALLENDER & CO., No. 42 Pine Street, New York.

KING'S TREATISE ON COAL GAS.

The most complete work on Coal Gas ever published. Three vols., bound \$30.

A. M. CALLENDER & CO., No. 42 Pine Street, New York,

GAS METERS.

GAS METERS.

GAS METERS.

GEO. J. McGOURKEY, Pres. WM. H. McFADDEN, Vice-Pres. (Phila.). WM. N. MILSTED, Gen. Supt. & Treas. (New York). WM. H. DOWN Sec.

AMERICAN METER COMPANY.

WET AND DRY GAS METERS.

PRESSURE REGISTERS.

METER PROVERS.

STATION METERS.

PRESSURE & VACUUM REGISTERS.

PORTABLE TEST METERS.

EXHAUSTER GOVERNORS.

PRESSURE & VACUUM GAUGES.

EXPERIMENTAL METERS.

DRY CENTRE VALVES.

CRESSON GAS REGULATORS.

AMMONIA TEST METERS.

GOVERNORS FOR GAS WORKS.

MARSLAND WATER METERS.

BAR AND JET PHOTOMETERS.

Manufactories:

512 W. 22d St., N. Y.
Arch & 22d Sts., Phila.

GAS STOVES,

SUGG'S "STANDARD" ARGAND BURNERS,
SUGG'S ILLUMINATING POWER METER,
Wet Meters, with Lizar's "Invariable Measuring" Drum.

Agencies:

177 Elm Street, Cincinnati.
214 & 216 N. Wells Street, Chicago.
810 North Second Street, St. Louis.
222 Sutter St., San Francisco.

HELME & McILHENNY,

(Successors to Harris & Brother. Established 1848.)

GAS METER MANUFACTURERS,

CONTINUE AS HERETOFORE AT THE OLD ESTABLISHMENT,

Nos. 1339 to 1349 Cherry Street, Philadelphia, Pa.,

To Manufacture Wet and Dry Gas Meters, Station Meters, Experimental Meters, Meter Provers, Center Seals, Pressure Regis-

GOVERNORS, INDICATORS, PHOTOMETERS, & ALL OTHER KINDS OF APPARATUS FOR USE IN GAS WORKS.

From our long practical experience of the business, and from our personal supervision of all work, we can guarantee all orders to be executed and in every respect satisfactorily.

WM. WALLACE GOODWIN, Pres. and Treas.

WM. H. MERRICK, V.-Pres.

S. L. JONES, Sec.

S. V. MERRICK

THE GOODWIN GAS STOVE AND METER

Successors to W. W. GOODWIN & CO.

1012, 1014 and 1016 Filbert St., Phila., Pa.

76 Dearborn St., Chicago

WALDO BROS., Agents, 88 W

MANUFACTURERS OF THE "SUN DIAL" GAS STOVES,

Dry and Wet GAS METERS, Station Meters (Square, Cylindrical, or in Lamp Post Meters, Etc., Etc., Meter Provers (sizes 2, 5 and 10 feet), Pressure Registers, Pressure Indicators (sizes 4 inch, 6 inch and 9 inch), King's Pressure Meters, Exhauster Governors, Photometers of all descriptions. Letheby's Sun Testing and Chemical Apparatus of all kinds, and of the most perfect

GOODWIN'S IMPROVED LOW

Agents for Brav's Patent C

Special attention to repairs of Meters, and all apparatus connected with them. All work guaranteed first class in every particular, and orders filled

D. McDONALD

GAS METER MANUFACTURERS

(Established 1848)

51 Lancaster St., Albany, N. Y. 3

STATION METERS, EXPERIMENTAL METERS, METER PROVING

Also STAR GAS STOVES, RAN

We use only the very best materials, and employ the most skilled labor, and by this we feel justified in assuring the public that our goods will give perfect satisfaction. Every article we sell has a TRADE MARK, and will be fully warranted by us. Our Annual and Calendar will be sent to

GAS ENGINES.

GAS ENGINES.

“Otto”

Gas Engine Works,

Schleicher, Schumm & Co.,

CHICAGO,

PHILADELPHIA.

New York Agency,

VESEY ST.

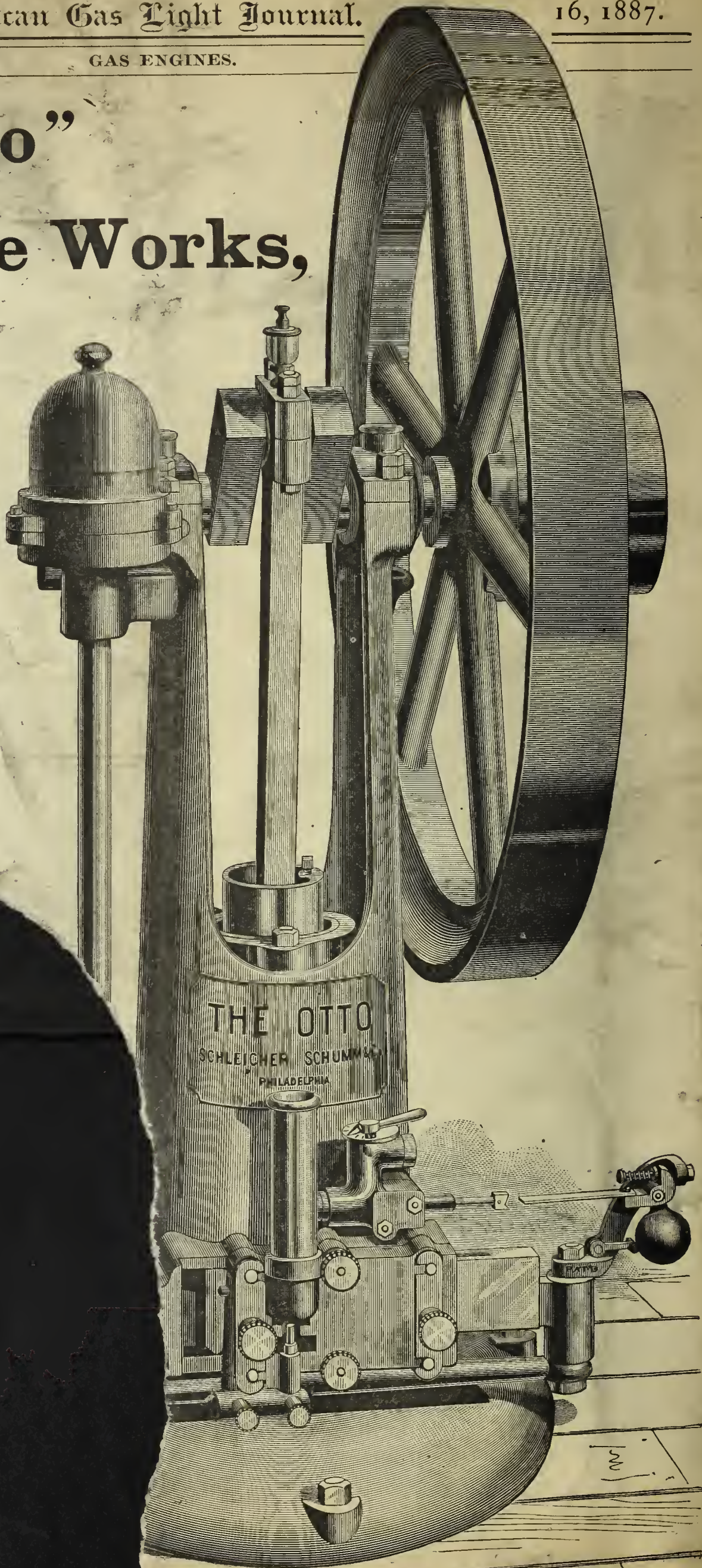

THE AMERICAN

GAS LIGHT JOURNAL

REDMAN & KENNEDY, N. Y.

PUBLISHING OFFICE No. 42 PINE STREET

DEVOTED TO THE INTERESTS OF ILLUMINATION, VENTILATION, WATER SUPPLY AND DISTRIBUTION, & GENERAL SCIENCE.

VOLUME XLVII.—No. 7.
Whole No. 679.

NEW YORK, MONDAY, OCTOBER 3, 1887

\$3 PER ANNUM,
IN ADVANCE.

A. M. CALLENDER & CO., Proprietors. C. E. SANDERSON, Manager.
JOS. R. THOMAS, C.E., Editor. T. J. CUNNINGHAM, Asst. Editor.

ENTERED AT THE POST OFFICE AT NEW YORK, N. Y.
AS SECOND CLASS MATTER.

Published on the 2d and 16th of each month, at No. 42 Pine Street, N. Y.

Terms of Subscription, including Postage.—For the United States and Canada, \$3 per annum. European countries, \$3.50 (15 shillings—18 francs). All payments to be made in advance. Single copies, 15 cents.

Remittances should be made either by post-office order, registered letter, or bank draft on New York, payable to the order of A. M. Callender & Co.

Correspondence.—Wishing to make this JOURNAL a gazette of intelligent discussion to those of our readers who may wish to gain or give information on the subjects to which its columns are devoted, correspondence is solicited for publication from all who make the study of those subjects a pleasure or a profession.

CONTENTS.

An Asterisk (*) denotes an illustrated article.

OFFICIAL NOTICE—

American Gas Light Association..... 193

EDITORIALS—

The Exeter Disaster..... 194

Welcome Home..... 194

The Manufacture of Coal Gas—An Abstract of Four Lectures, by Mr.

Lewis T. Wright..... 195

*The Waterhouse Standard Ammeter..... 199

The English Gas Companies and Mineral Oil..... 199

Compressed Air as a Motive Power..... 200

Special English Correspondence..... 200

Mr. W. J. Doherty on Photometrical Standards—Gas and the Stage—A New Edition of Lunge on "Coal Tar and Ammonia"—A Petroleum Scare.

ITEMS OF INTEREST FROM VARIOUS LOCALITIES..... 202

Death of a French Gas Engineer—Electric Light for the Bureau of Printing and Engraving—New Gas Company—Public Lighting at San Antonio, Texas—Successful in any Event—An Agency Dissolved—Concerning the Chicago (Ills.) Gas Bonds—Will Marysville (O.) Have a Gas Works?—Public Lighting at Helena, Montana—Cheaper Gas for Elizabethtown, N. J.—Bro. Gwynn is at it again—To Bring the Suit—New Station Meters—A Great Success—Annual Election, East Portland, Oregon—Sumter (S. C.) to be Lighted by Electricity—Destroyed—Absorbed—The Law as it Stands—Extending the Main System—New Electric Light Companies—To Furnish Electric Light, Too—About the Sacramento (Cal.) Gas Company—Franchise Allowed—To Put in an Electric Plant—Cheaper Gas for Keokuk, Iowa—Light for Grand Island, Neb.—Assigned—Public Lighting at Washington, Ind.—Reported Adversely—Columbus (Ga.) to Have Electric Lights—The Combination Plan at Jackson, Teun.—Send for a Copy—Other Meters Underway—Will They Succeed?—An Electric Plant—Other New Gas Companies—The Sloper Patent Sufferers—More Patent Apparatus—Annual Report Jamaica Plain (Mass.) Gas Light Company.

Mersault's Coal Washer..... 205

Briefly Told..... 205

CORRESPONDENCE—

A Simple Plan..... 205

The Market for Gas Securities 206

[OFFICIAL NOTICE.]

American Gas Light Association.

SEPTEMBER 28, 1887.

To the Members of the Association :

GENTLEMEN : The fifteenth annual meeting of the American Gas Light Association will be held, as already announced, on Wednesday, Thursday and Friday, October 19, 20 and 21. The Convention will be called to order on the morning of the first-mentioned day, at ten o'clock, by

the President, Malcolm S. Greenough, Esq., of Boston. The local Committee of Arrangements has not completed yet all the work committed to it, so I cannot now give a complete programme of the Convention, but I can lay before the members the chief features of the meeting.

As I said in my last circular, the difficulty of arranging for the accommodation of the members of a convention in New York city during the fall months increases rather than decreases year by year, so that it is now found impossible to provide for the care of all the members at a single hotel : hence the Committee, in deciding on the headquarters of the Association, endeavored to secure a hotel which would be adjacent to other hotels, in order that the members might be near each other, as the pleasure of being under one roof would be denied them. It has, therefore, been arranged that the headquarters shall be at the Sturtevant House, and accommodations for the members will also be provided at the Coleman and Grand. The Sturtevant House is situated at the corner of Broadway and Twenty-ninth street, and is run on the American plan. The Coleman is at the corner of Broadway and Twenty-eighth street, and is run on the European system. The Grand is also on Broadway, being at the corner of Thirty-second street. It likewise is run on the European plan.

Members should secure rooms in advance, by writing direct to the hotel at which they intend to stop.

The meetings will be held at Dockstader's Minstrel Hall, directly opposite the Sturtevant House.

The banquet will take place on the evening of the 20th. The tickets will be \$5.00 each.

The papers so far promised are the following :

"Fuel Gas," by Emerson McMillin, of Columbus, Ohio; "Illumination vs. Candle Power," by Alex. C. Humphreys, of Philadelphia, Pa.; "Utilization of Residual Products," by Chas. H. Nettleton, of Birmingham, Conn.; "The Advantages of Gas Companies Engaging in the Electric Light Business," by E. J. King, of Jacksonville, Ill.; "Water Gas," by Walton Clark; "Development of the Half-Depth Regenerative Furnace and Some of the Results," by O. B. Weber, of New York; "The Comparative Illuminating Power of Gas Purified with Lime vs. Oxide of Iron," by C. W. Blodget, of Brooklyn, N. Y.

We have also the partial promise of a paper treating of the value of coke for the purpose of making steam. It has been suggested to me that it would be well to have a paper on "The disadvantages arising from the fluctuations in candle power, owing to experiments, the irregular mingling of gases, etc." I would be glad to have someone come forward with a paper on this subject. I would also remind the members that we are still in need of essays in order that the time of our meeting should be filled up nicely. I would be glad to have some volunteers come forward. I would suggest that the members be thinking over the topics given in the foregoing list of subjects, and come prepared to make the discussions lively. If a member has a subject in mind which he would like to have discussed at the meeting I would be pleased to hear from him. It has been suggested to me that a paper on the value of coke for the making of steam would be very useful. Some members have trouble in selling their coke, and have tried to induce steam users to employ it in place of coal, but find trouble in pushing its use for this purpose. If

someone who has had experience in this direction would write a paper on the subject, showing the value of coke as compared with coal, it would probably be of assistance to some of the members.

I am able to state that on the third day of the convention an excursion up the Hudson river will be tendered to the members of the Association and their friends.

Respectfully,

C. J. RUSSELL HUMPHREYS, Sec.

THE EXETER DISASTER.

In these days of brisk competition in all branches of commerce and industry—a competition that grows keener with every forward stride taken either in the development of old methods, or the putting on of that which is comparatively new to practice or unknown to fame—it is but natural that rivals for public favor should seek to make capital for their own interest out of the failings or mishaps of their competitors. It matters not to the carper whether his snarl is based on the groundwork of fairness; and we fear that the average business rival shares in some degree the practice of the first named. Give the minimum starting point of fact to either, and the subsequent elaboration of fact and fancy causes the construction of a most wonderful argument—wonderful chiefly because of the length or volume of the argument that is bound together by so little of the cement of truth. While human nature remains as it is—and we fear that the records of the past necessarily forbid us to believe that but slight amelioration of its leading impulses is to be expected in the future—we must accept the inevitable, and plod along, satisfied at last if partial justice be done. Just now the newspapers of the world are discussing the details of the recent destruction by fire of a pretty theater located in Exeter, England, and the horrible holocaust that accompanied the blighting touch of the flames which consumed it. We are told that nearly if not quite 200 souls perished miserably within its doomed walls; and the very thought causes the people of this country to, with added horror, revert to that bleak night in December, many years ago, when the same devouring element plunged the third city of the Union in mourning. Thousands of our citizens will recall the destruction of the Brooklyn Theater, which disaster caused the death of hundreds. We are told by the advocates of electric lighting that these and similar catastrophes were directly traceable to the method followed for the interior illumination of the structure. Perhaps they hardly put it that way, for then they would be asserting the real truth. No; they say, baldly, "Gas caused the conflagration." And that is followed up by the wonderful argument so strangely constructed out of fancy but with such a small binding of the cement of truth. The gas light no doubt was the agent that started the deadly blaze; but is the method under which the gas was used not alone responsible for the ensuing effect? Our English correspondent, in speaking elsewhere in our columns about the Exeter disaster, says: "Prevention is better than cure, and the lights must be inclosed in cases; so that there is no risk of the 'flies' blowing against the miserable wire globe which is called a protection(?) to the gas burner. The heated products of combustion must be removed, and not allowed to come in contact, possibly at a distance of a few feet above the flame, with closely packed rolls of canvas scenery, painted in oil or other inflammable substances. I learn that the Exeter stage was closely packed with scenery. So long as large quantities of gas are consumed on stages 'closely packed with scenery,' with no provision for preventing the heated products of combustion from coming in contact with the same, so long will there be the risk of conflagration." And he might have added thereto, that that risk will exist under those conditions whether gas or electricity be employed to perform the lighting. We do not wish here to claim that gas lighting is free from danger, but we do assert that those in charge of the illumination of places of public assembly—and theaters particularly—can cause that duty to be carried out by gas in a manner as free from peril as that which attends any other lighting system. But the wire globe and the naked jet must go, for fit and safe appliances are at hand to supersede them; and if the parsimonious theater proprietor objects on the score of increased expense perhaps the law may ultimately force him to adopt less penurious views. As hinted before, the necessities of competition have induced the electricians to loudly ring the changes on the dangers of gas as an illuminant, and each unfortunate example of the nature of the last one, unhappily furnished by the Exeter catastrophe, is paraded before the people as proof of the saving virtue of the electric current. Comparisons, save in extreme cases, seldom advance anyone's cause; but while the electrical din sounds shrillest, we would call the attention of those interested to the verdict (rendered last January) of the jury who investigated the causes that led to the destruction by fire of the Temple Theater and Museum, Philadelphia, Pa., on the night of December 27, last. The building was lighted throughout by incandescent

lamps, but, fortunately for humanity, the fire occurred at an hour (11 A. M.) when perhaps not a score of visitors were on the premises. Well, after three weeks of patient investigation, it was determined that the fire was caused by electricity, and it was also agreed upon, "That without proper workmanship, care and conditions, it is possible to cause fire by means of incandescent light circuits of low potential in many ways," which sentence explains it all. A sane man would not expect to prolong his life by thrusting a torch into an open (or air-tightly closed, either) keg of gunpowder; but seemingly sane theatrical managers so arrange gauzy "flies" that a slight puff of air will waft the gossamer right over a "wire-protected" gas light. If safety is to be expected in such instances, "proper workmanship, care and conditions" must constantly prevail, be either gas or electricity employed as the lighting agent.

In closing our reference to this matter, we herewith reproduce the following editorial comment on the Exeter disaster as made in the last issue to hand of the *London Journal*:

"The Opera Comique in Paris was burnt down in May last; and upon that occasion 100 people lost their lives. Last week this catastrophe was far surpassed by the terrible fire at the Exeter Theater, when nearly 200 persons perished in the flames or by suffocation or crushing. This was the most dreadful occurrence of its kind that has ever been recorded in the history of conflagrations in this country; and at the moment of writing these lines the shock of it still agitates all ranks of the people. We do not mention the deplorable event merely for the sake of printing a few words upon the subject that is at present uppermost in most men's minds, or to add anything to the speculations that have been advanced respecting the origin and course of the fire, and the influence which its effects may exert upon the arrangement of theaters now or to be built. It is necessary, however, that we should not pass over, without due recognition, the assertion, which is probably correct enough, that this terrible fire was caused by the ignition of some gauzes which, for scenic purposes, were placed near the gas battens in the 'flies' of the stage. After the manner of their kind, electricians of the advertising class have rushed into print to point the moral of this statement, which is, according to them, that gas should be abolished from the theaters, and electricity placed in its stead. Now it is perfectly open to any believer in gas as a means of lighting theaters in common with other public and private buildings, to argue, on the contrary, that the true moral of a disaster of this character is not that gas should be banished, but that it should be properly used. In the first place, if nothing but electric lighting can be depended upon for theaters, it follows that the days, or rather the nights, of the drama in the provinces are numbered. We have no hesitation in saying that the cost of electric lighting would be prohibitive in the case of the very great majority of provincial theaters, the less of which have in most cases the greatest difficulty in making both ends meet. They can hardly pay their gas bills; how then could they pay twice or three times as much for incandescent lighting? They would prefer to shut up their houses altogether. It is a good stroke of business on the part of certain London theaters to advertise the fact that their houses are lighted wholly or in part by electricity; but would the same men, if they had to run a theater in a small, quiet cathedral city undertake to pay as much as they now do for their lighting bill? The idea is absurd. If gas lighting is not to be trusted, the British provincial drama is doomed to extinction. But there is no reason why gas should not be used, provided that proper precautions are taken, firstly, to prevent fires; secondly, to localize them; and, thirdly, to enable places of entertainment to be emptied in the shortest possible time. With the question whether public places of amusement should or should not be put under the supervision of a Government Inspector, we have here nothing to do, save to acknowledge that under some such system the crude, inefficient, and scamped arrangement of the gas lighting in many theaters besides that at Exeter, which are actually a peril to the public, would be corrected."

WELCOME HOME.

Mr. E. Stein, of the Siemens-Lungren Company, of Philadelphia, arrived home on Saturday last, looking the picture of contentment, happiness, and health. The good ship Umbria, to which he intrusted his avoirdupois, came pretty near wiping out the record of previous fast ocean voyages, having compassed the journey in 6 days 5 hours. In fact, it was hinted that if Brother Stein kept proper direction over his movements when promenading the Umbria's deck, the ocean greyhound might have actually clipped the record. He reports great activity existing in English gas circles, and notes that not a single arc light is used in the public street lighting of London. Mr. S. has brought over one or two novelties, and of these notice will be made at the proper time.

Mr. R. P. Spice sailed Saturday for America. His objective point is the coming meeting of the American Gas Light Association.

The Manufacture of Coal Gas.

[An abstract of four lectures delivered, by Mr. Lewis T. Wright, F. C.S., etc., and Engineer to the Nottingham Corporation Gas Department, before the City and Guilds of London Institute. The chief object of the lecturer was to prepare students to satisfactorily pass the examinations shortly to be made in the department of the Institute devoted to a study of the subject of "Gas Manufacture." That intention explains the elementary character of Mr. Wright's discourse. Our report is taken from the *London Journal*.]

The first lecture was devoted to a consideration of the raw material used in the manufacture of gas, and was illustrated by specimens of various classes of coal, and of the coke made therefrom; while on the wall was a table giving analyses of the following descriptions: Nottinghamshire Silkstone, Derbyshire Silkstone, South Yorkshire Silkstone, Newcastle coal, cannel from the Barnsley seam, *pseudo-cannel*, cannel from the Silkstone seam, and Australian cannel. The lecturer commenced by saying that the manufacture of coal gas is one of those modern inventions which help to distinguish the present century from all preceding ones. In common with the use of the steam engine, it has spread within the last three-quarters of a century all over the civilized world, until there is now hardly any town in which gas is not the principal illuminant. The making of gas has also had its influence upon other chemical manufactures, being the starting point of many scientific and commercially valuable operations. Theoretically, it must be treated as a chemical, and not as a mechanical operation. Any manufacturing process which changes the appearance and form only of a material, without changing its chemical composition, is a mechanical operation; but any manufacture which has for its object the chemical alteration of a material, by depriving it of some of its constituents by adding to them or by dividing and rearranging them, so as to produce new bodies having new properties and uses, is a chemical operation. It has been the fashion to treat gas manufacture as an engineering business; and so it is in respect to the lifting, transporting, and handling of the bulky materials which have to be moved about a gas works, and also as regards providing the machinery and plant necessary for the various operations; but in its theory it is purely mechanical. In practice it is partly chemical and partly mechanical.

As the basis of every chemical manufacture there is some raw material, which has to be made the subject of the chemical and engineering operations; and the raw material of gas works is the fossilized *debris* of the carboniferous age. Though there are other geological formations which contain deposits of coal, and of substances allied to it, yet in this country at least the coals employed for gas making purposes are all obtained from the upper and middle carboniferous series. Every coal, however, is not suited for gas making; some, like anthracite, being quite useless for this purpose. But there are many qualities of coal which are never used by the gas maker, and which might be used but for the competition of better qualities. Though the varieties of coal are very numerous, they are capable, for the purpose of gas making, of being divided, with tolerable sharpness, into two classes—first, caking coals, or those which give, on distillation, a volume of gas of from 9,800 to 11,000 cubic feet per ton, and ranging in quality from 14 to 17½ candles; and, secondly, cannel coals, giving from 10,000 to 15,000 cubic feet of gas per ton, of a quality ranging from 20 to 45 or even 50 candles. Of the 8½ million tons of coal annually employed in gas making in this country about 7¼ millions are common coals, and only 1½ millions are cannel. Common coals, although yielding gas of lower luminosity than cannel, are found more profitable, because, being more abundant and more easily worked, they are cheaper; and also because they give a coke of considerably greater commercial value than that produced by cannel. This distinction cannot always be sharply drawn. The Wigan cannel, for instance, yields a coke similar to that from caking coal; it is therefore called caking cannel. Any sample of coal will, on examination, be found either to consist of laminations of varying thickness and of different kinds of coal, or to be homogeneous in appearance, giving no sign of lamination or stratification. All the common or caking coals are laminated, and consist principally of two kinds of coal. The first is a bright, glistening material, like black glass, and having a cross fracture in the thicker laminations more or less cubical. The second variety is a duller material, more like charcoal. The relative proportion between the glassy coal, called "jet" coal, and the dull kind, called "smut" coal, determines the character of the coal. Evidences of smut or charcoal will be found in every laminated coal, and traces of it may also be found in cannel. This material is really a charcoal—being woody matter which has already been submitted to a carbonizing action; and it is therefore of very little value for gas making. On heating it neither

coke nor alters its appearance, though it loses some 20 per cent. of volatile matter; and the analysis of it, showing a very small percentage of hydrogen, is very significant. The bright coal is much richer in hydrogen than the smut coal, and contains less ash. Very hard coals are built up of alternate laminations of bright coal and of charcoal. The finest caking coals do not contain more than 2 per cent. of ash, which should be light, similar in structure to the ash of wood, and varying in color from white to a brick red. In some coals the charcoal and earthy appearance are almost entirely absent; and it is only on very close inspection that the laminated character can be detected. Thus they have, to a certain extent, the appearance of cannel, and are sometimes called and sold by that name. This material occurs in tolerable thickness, and contains but little ash—therein differing from cannel; and on distillation it cokes into a very fair gas coke.

In the term "cannel" are included many kinds of coal, the extreme members of which offer more differences in practical results than the other class of coals. Under this head are included all hard, non-laminated coals having a homogeneous character. When having a flaky fracture and earthy appearance it is often called shale. In gas phrasology all hard coals, homogeneous in appearance, and yielding gas of 20-candle power and upwards, are called cannel. The richer classes are dull and brown; the poorer or secondary cannels are generally bright and black; the third class, yielding gas of about 20-candle power, are dull and black. True cannels do not cake, but yield on distillation a residue similar (with the exception of some cracks and fissures) to coal. These cracks, however, indicate the laminated structure which was not visible in the original cannel. The ash is greater in quantity than in caking coals, and often shows the laminated structure more clearly than the coke. Cannels yield more tar and of a lighter specific gravity than caking coals.

Whilst the physical difference between common coal and cannel is well marked, the same cannot be said of the chemical differences between the various cannels and the caking coals; certain cannels having precisely the same elementary composition as some caking coals. In common cannels, yielding about 10,000 cubic feet of 21-candle gas per ton, the carbon is about thirteen times as much as the hydrogen. In the highest members, such as Boghead or Australian shale, the carbon is from 7.2 to 7.7 times the hydrogen. Coals vary in quality inch by inch, not only vertically, but laterally in the same seam; and this makes it impossible to determine the character of any particular coal simply by the inspection of an analysis. The structure of cannel is suggestive of its having been originally in a highly divided form as an organic mud; and it leaves on combustion an ash as bulky as the coal. The richest cannels generally contain most of this earthy admixture. This is a very troublesome property, because it makes their cokes difficult to consume in furnaces; the ash, which is very light, blocking up the airways, and preventing the access of air to the furnace. [The lecturer here gave a description of the principal coal fields, and described the characteristics of the coals obtained from each; pointing out that the same seam would sometimes produce every variety, from rich cannel to anthracite, so that the district, or even the seam from which the coal was produced, was not an absolute criterion of the quality of coal likely to be obtained.]

Another feature to be observed in connection with coals is the destructive agency of atmospheric exposure—alternate wettings and dryings, changes of temperature and frost. Cannel coals suffer less from exposure than the caking coals. When coal is distilled in a gas works there are four principal products obtained: (1) A luminous gas; (2) tar; (3) water, holding in solution certain salts of ammonia; and (4) the carbonaceous solid residue known as coke. These, again, are each mixtures of various bodies, which in their turn are capable of separation. Newcastle coal produces about 70 per cent. of coke; the tar is rather low, and also the sulphur compounds. There is nothing remarkable in the nitrogen, which is rather higher than in Derbyshire coal—not less, as is sometimes stated; the reason probably being that in some parts of the country, where Midland coal is chiefly used, scrubbing is more carefully conducted than in the South where Newcastle coals are mainly employed. It is worthy of notice that as the amount of moisture or natural liquor increases the tar becomes thinner, and the specific gravity decreases. Probably the presence of so much steam in the distillation products protects the tar from the destructive action of the heat in the retorts. The products obtained from any coal are strictly limited by the elements constituting it. It is impossible by any method of distillation to get out more carbon or more hydrogen from the coal than it originally contained.

With regard to coal analysis, there are four methods in common use. The first is that of proximate analysis, as described in chemical text books. The second is elementary analysis, as also described in books on quantitative analysis. By this method it is difficult, and in some cases

even impossible, to determine anything as to the character of the coals. The third is practical analysis, as ordinarily carried on in an experimental iron retort set over a furnace of firebrick (to which is attached a small condenser for collecting the tar and water), a purifier, and a gas-holder, in connection with a photometer for determining the illuminating power. The usual quantity of coal employed in such analysis is 1000th of a ton. Most of the public analyses and those issued by collieries are obtained in this way, which gives results from 5 to 10 per cent. higher than with clay retorts on the large scale. The results arrived at in this way are the volume and quality of gas, and the quantities of tar, liquor and coke; but nothing can be learnt as to the quality of the coke. Then there is the fourth or practical analysis on the large scale, conducted with apparatus similar in size and in every other respect to that used in gas works. At Nottingham the plant is identical with that employed on the works; and by means of such tests accurate information can be obtained on all points of interest. Many people think that the laboratory analysis, which, no doubt, gives an indication of what is really in the coal, is the best mode, and that the results shown can be obtained in practice; but this is not the case, because, as will be seen later on, it is impossible practically to get the whole of the gas that is in the coal.

The second lecture was devoted to a consideration of the distillation process. The distillation products of two substances having the same elementary composition, such as starch and dextrin, were, the lecturer said, not identical; depending, among other things, upon the temperature, but also on the original constitution of the bodies operated upon. In the distillation of coal the process went on by steps, and consisted partly of breaking up and partly of reconstruction, and was much complicated by the presence of nitrogen and sulphur in addition to carbon, hydrogen and oxygen. The tendency now-a-days, he continued, was to the use of broad A-shaped clay retorts; the manner of setting which he briefly explained. These fireclay retorts when in use cracked and allowed the escape of gas to some extent: though this was largely prevented by the deposition of carbon on the interior. The amount of gas lost in this way had not been exactly determined, but was probably more than most people imagined. Economy of fuel was a great point in carbonizing coal, and depended on the proper supply of air. This was best attained by dividing the air supply into two portions by means of a generator furnace, which had also the advantage of heating both the primary and the secondary supply of air. The details of mouthpiece, ascension-pipe, dip and hydraulic main were described. The latter, the lecturer remarked, acted not only as an automatic valve and gas collector, but also as a condenser; 60 per cent. of the tarry particles in the gas being deposited there in a liquid form. The phenomena of choked ascension-pipes and plugged hydraulic mains were next explained, and the causes pointed out. The modern tendency was to distil coal at higher temperatures; thus not only driving off more free carbon, but also increasing the temperature of the hydraulic main, and thereby preventing it acting well as a condenser. To remedy this it was necessary to devise means for securing a circulation of the liquid in the main. It was certain that the increase of temperature in the process of distillation augmented the volume of gas given off, but at the same time it lowered the illuminating power, and also the weight of tar, though it doubled the amount of free carbon in the tar, its specific gravity being increased. The higher heats also produced more bisulphide of carbon and sulphuretted hydrogen. The product which was most remarkable, however, with high heats was cyanogen, which was ten times as great with high heats as with low ones. A very low temperature was unfavorable to the production of ammonia; but at a temperature giving about 9,500 cubic feet of gas per ton of ordinary coal, it reached its maximum—higher temperatures again showing a diminution. Other causes, however, not yet ascertained, also affected the proportion of ammonia. On the whole, the balance of advantages was in favor of high heats. This was exemplified by two tables showing the products of 100 parts of Derbyshire Silkstone coal, distilled at high and low temperatures respectively. Cannel coal, the lecturer went on to remark, behaved in a somewhat similar manner; but there was rather less diminution of illuminating power at high temperatures. There were great differences in the character of the coke produced from the same coal, partly dependent on the temperature employed, and partly on the kind of retort used. Gas coke was often spoken of as carbon; but it also contained nitrogen, sulphur, hydrogen and oxygen. The distillation products generally varied with the origin of the coal; Newcastle yielding a different class of tar, etc., to Derbyshire and South Yorkshire, which was probably the purest of all.

The third lecture was devoted to the subject of the removal of impurities from the gas. Crude gas, it was stated, may be said to enter the

purification stage directly it reaches the hydraulic main, at which point the impurities consist of tarry bodies, carbonic acid, ammonia, sulphuretted hydrogen, and sulphur compounds other than sulphuretted hydrogen. Ammonia and sulphuretted hydrogen are always legal impurities; and the other sulphur compounds are sometimes prohibited to a greater extent than from 15 to 25 grains per 100 cubic feet. In the first place, the gas has to be cooled; and as it cools the vapors of various hydrocarbons and their organic compounds with watery vapors condense into the liquid form. Some of these bodies, however, still remain suspended in the gas in the form of fog. The temperature to which the gas can be lowered is dependent to some extent on atmospheric influences; but the operation is extremely simple—the gas having only to be conveyed through a series of iron pipes offering sufficient superficial area, and freely exposed to the air. The amount of condensing surface required varies with the quantity of watery vapor and tar in the crude gas. For gas yielding about 12 gallons of liquor per 1,000 cu. ft., it should be 5 to 6 superficial feet; while for gas yielding more liquor—some going as high as 25 gallons—10 or more superficial feet of cooling surface are required for each 1,000 feet made per diem. The operation termed condensation is, in reality, twofold—consisting, firstly, in cooling the gas to the required temperature; and, secondly, in clearing it from the liquefied tar, watery vapor, etc. The orthodox methods in use do not completely effect the second object; and although isolated attempts have been made to introduce other apparatus after cooling, they have not yet assumed a sufficiently successful shape to become generally adopted, and the usual course is to clear the gas of the tarry vapors in other parts of the plant. If the cooling has been efficient, practically the whole of the tar and the water (which contains certain ammonia salts) are, by a suitable overflow arrangement, let off into the tar-well. In some works the tar and liquor flow together into an apparatus called a separator, which divides the tar from the liquor, and sends each liquid forward to its proper receptacle. In other cases the separation takes place in the well. The pipe connecting the outlet of the hydraulic main with the condenser is called the foul main, and at the entrance to the condenser is a seal-pot or tub into which the main dips, so as to allow the tar and liquor to flow one way whilst the gas passes the other into the condenser. If the tar from the hydraulic main and that from the condensing apparatus be separately collected, they will show considerable differences both with regard to specific gravity and the proportion of free carbon; the latter being lighter, and containing 15 to 18 per cent. of free carbon, as against 30 to 35 per cent. in the former. The liquor also varies in composition. One-half of the total ammonia is generally deposited during the process of condensation; and the remainder has to be dealt with by special means afterward. When the ammonia is absorbed by the condensed water, it combines with carbonic acid, sulphuretted hydrogen, hydrochloric acid, sulphocyanogen, and other bodies, forming ammonium compounds with these various acids, which are found in the liquor. At the outlet of the condenser an exhauster is placed for the purpose of drawing away the gas from the retorts, and forcing it through the purifiers and into the gas-holder. On the inlet side, therefore, there is a vacuum sufficient to overcome the resistance of the seal in the hydraulic main, and also any resistance in the condenser, which may be taken at $2\frac{1}{2}$ inches. On the outlet side the pressure will be about 24 inches—viz., 2 inches for the scrubber, 14 inches for the purifiers, and 8 inches for the gasholder; but this varies with the character of the plant.

The next operation is to remove the remaining ammonia, which is effected by washing with water. The liquor naturally condensed will also absorb a good deal more ammonia; and it is therefore used for this purpose—thus making the liquor more concentrated, and consequently more valuable. At Nottingham two scrubbers are employed in this way, consisting of circular towers 12 ft. in diameter and 60 ft. high; their cubical capacity being 6,750 cubic feet per 100 tons of coal distilled per diem. The gas enters at the bottom, and rises up to within a few feet of the top; the space being filled with boards, over which the liquor trickles down to the bottom, where it makes its exit by means of a seal cup, and flows away to the liquor well. Steam pumps are employed to force the liquor to the top of the scrubbers. As the gas leaves the scrubbers it contains only one-tenth of its total original ammonia; and this is removed by washing with clean water in a horizontal washer, consisting of a closed tank divided into compartments, through which runs a shaft carrying bundles of thin iron plates, which are kept constantly revolving in water at the bottom so that a large surface, continually wetted, is presented to the gas. By the use of from 2 to 4 gallons of clean water per ton of coal distilled the last traces of ammonia may be removed. The operation of scrubbing, however is largely affected by the temperature; and in very hot weather the results just stated cannot be realized. The strength of the liquor turned out by a gas works recovering the whole of

its ammonia will be determined by the amount of ammonia in the gas and the quantity of liquor containing it. If there are 7 lbs. of ammonia to 1 ton of coal, and the coal yields 18 gallons of natural liquor, 2 gallons of additional clean water being required to thoroughly cleanse the gas, there will be 20 gallons of liquor, the strength of which will be $3\frac{1}{2}$ per cent.—equal to about 16-oz liquor or 8° Twaddel. When the temperature is over 70° , liquor of 8° Twaddel cannot be run down the scrubbers without loss of ammonia, and then more clean water must be used in the horizontal washer. As a matter of fact, the strongest liquor is not made in the summer, when the plant is being less worked, and therefore when the capacity of the scrubbing plant is greatest in proportion, but in the winter, when the weather, being cold, is favorable to the formation of some of the ammonia compounds. The amount of ammonia varies largely with different coals, and also with the circumstances of the distillation. About 20 per cent. of the ammonia in the liquor combines with the sulphuric, hydrochloric, and other acids; and as the salts thus formed do not decompose on simple boiling, this is called fixed ammonia. There will be found 80 per cent. in combination with certain feeble acids, carbonic acid, hydrosulphuric acid, and sulphuretted hydrogen; and as this can be expelled by boiling, it is technically termed free ammonia. The trouble in scrubbing in warm weather is caused by the fact that this free ammonia is easily dissociated by heat; and as the temperature rises this tendency increases. The 80 per cent. of ammonia which is combined with the carbonic acid and sulphuretted hydrogen forms two series of compounds—one in which two volumes of nitrogen combine with two of the acid, and the other in which four volumes of nitrogen combine with two of the acid. If the first series alone were formed the ammonia would do double the amount of work in removing the other sulphur compounds; but this cannot be secured. As a matter of fact, 100 volumes of nitrogen will be found to combine with $62\frac{1}{2}$ volumes of the two acids; but not in equal proportions. The carbonic acid is always in considerable excess over the sulphuretted hydrogen; roughly speaking, in the ratio of 50 : 12 $\frac{1}{2}$ —varying with the strength of the liquor and the temperature at which it is made. The gas liquor condensed in different parts of the gas plant will vary very much; and these figures apply to the total product.

Having been freed from ammonia, the gas still contains the surplus carbonic acid, sulphuretted hydrogen, some bisulphide of carbon and cyanogen. The whole of these bodies can be removed by the use of moist slaked lime; but, for reasons of economy, it is usual to employ oxide of iron to remove the sulphuretted hydrogen, with which it forms two sulphides—one (monosulphide) very soluble, and the other insoluble in water. The sulphhydrate, and very possibly the hydroxide, has the property of absorbing bisulphide of carbon; and it is used for this purpose in the process of gas purification. These sulphur compounds, if once formed, cannot be entirely destroyed by the continued action of coal gas containing carbonic acid; but if calcium sulphhydrate and also sulphocarbonate are treated with such gas, there is a formation of calcium carbonate, with the elimination of sulphuretted hydrogen and bisulphide of carbon. In economical gas purification these opposing actions have to be controlled, regulated, and balanced. Oxide of iron, either as found naturally or artificially prepared, is in some forms active with sulphuretted hydrogen, forming two sulphides by an exchange of the oxygen for sulphur. The exact condition which makes the oxide active is not known; probably it is the hydrated oxide. Both sulphides are readily oxidized on exposure to the atmosphere, and the sulphur is then separated out; thus leaving the original material, ferric oxide or ferric hydrate. This gives a simple and economical means of getting rid of sulphuretted hydrogen by the continual sulphiding of the oxide and the reconversion of sulphide, with the elimination of free sulphur; and thus the same material may be used over and over again.

[A description was then given, with the aid of diagrams, of a series of purifiers, alternately lime and oxide. The arrangement recommended was one for first removing the carbonic acid by lime; next the sulphuretted hydrogen by oxide of iron; then the bisulphide of carbon by calcium sulphides or sulphhydrates of lime; and finally the last traces of sulphuretted hydrogen by clean lime or oxide. But it was pointed out that the order of these might be changed, so long as the removal of the bisulphide of carbon followed the other two.]

Normal Newcastle coal generally contains about 45 grains of sulphur other than sulphuretted hydrogen per 100 cubic feet of gas. Of this 10 grains will be removed by the carbonic acid vessels. The best oxide of iron comes from Ireland, and is known as bog ore. In some places it is usual to mix a quantity of sawdust with it to lighten it; but it is better not to do so if the purifiers are of sufficient capacity. This natural oxide usually contains 50 per cent. of water, 32 per cent. of hydrated oxide, and 18 per cent. of vegetable matter; only 22 per cent. of the oxide,

however, being in a form active with sulphuretted hydrogen, though it was not known whether the remaining 10 per cent. afterward became active or not. It does not work satisfactorily if it contains much more than 25 per cent. of moisture; in fact, the drier it is the better, so that it is not powdery or dusty, in which state it would fall through the grids of the purifiers. If the vessels are in a proper condition, the gas which enters the third purifier, filled with lime which has absorbed sulphuretted hydrogen and so become sensitive to bisulphide of carbon, containing 35 grains of bisulphide (10 grains having already been removed), leaves it with only from 8 to 10 grains of sulphur; and this will not be in the form of bisulphide, but in some form at present uninvestigated—probably cyanogen, or something of that kind, not active with any known reagent; and there are, therefore, no means of removing it. These vessels are not changed except at long intervals; which is so much the better, because when opened they are very offensive. It is, said Mr. Wright, a scandal to the gas profession that in many cases no steps are taken to avoid this nuisance, which has brought great discredit on the method of purification in question. The system thus described is a scientific one, because each pair of vessels has a specific duty to perform; and a very satisfactory result can be obtained with great economy. There are, however, other systems, some depending solely on the use of oxide of iron; but this does not remove the carbonic acid and bisulphide of carbon. Gas can also be purified by lime only, which will take out all the impurities; but in that case much more lime is required than when it is alternated with oxide of iron. Iron sulphides react on alkaline cyanides, with the formation of ferrocyanide compounds; and, finally, Prussian blue is obtained, which locks up a very large quantity of iron, and renders the oxide inactive. Oxide through which gas containing much cyanogen has been passed can rarely be made to hold more than from 38 to 40 per cent. of free sulphur. By treating it, however, with from 2 to 3 per cent. of lime well wetted, a certain amount of the iron is again liberated. On the Continent such iron can be disposed of for the sake of the Prussian blue it contains; but in this country it can only be sold for the sulphur. At one time the sulphur was extracted by means of solvents; but this was not found economical, and it is now roasted for the manufacture of sulphuric acid.

For determining the amount of sulphuretted hydrogen and carbonic acid in gas, it is washed, dried in a calcium chloride tube, and passed into another tube containing a mixture of copper phosphates, which absorb the sulphuretted hydrogen. It is then again dried, and sent into a tube charged with soda-lime, which absorbs the carbonic acid. A known quantity having been allowed to go through and weighed before and after each operation, the quantity of the impurities can be calculated. If the gas contains ammonia this must be first removed by passing it through a tube containing phosphoric acid. [Samples of oxide of iron and of lime in various degrees of impurity were exhibited; and the lecture was further illustrated by a large diagram of an ideal gas works, in which the different stages of the manufacture and purification were traced, from the coal truck to the pressure gage at the outlet of the gas-holder.]

The fourth lecture was devoted to a description of the various methods of gas analysis, and was illustrated by a collection of the most approved apparatus, lent by Messrs. Alex. Wright & Co., of Westminster. The lecturer commenced by remarking that purified coal gas was a mixture of hydrogen, carbonic oxide, and various hydrocarbons which are gaseous at ordinary temperatures. Prominent among them is marsh gas. There are also some hydrocarbons, which may be liquid at ordinary temperatures, and a small quantity of nitrogen. The presence of oxygen denotes careless manufacture and some atmospheric contamination. There are also traces of sulphur and certain other compounds of a phenolic character. The hydrocarbons are divided by chemists into two classes. The first comprises those which are absorbable by such reagents as fuming sulphuric acid or bromine, and which are generally called heavy or luminiferous hydrocarbons. Their precise composition, however, is not known, and they are, therefore, generally designated by the formula C_nH_n , as the precise number of atoms of carbon or hydrogen in the molecules is not known. The other class consists of those hydrocarbons which are not absorbable by fuming sulphuric acid or bromine, and these are called generally marsh gas. But, as a matter of fact, they may be marsh gas plus other members of the paraffine series; and the methods of gas analysis at present known are not sufficient to distinguish between mixtures of paraffines—so that all these are reckoned as CH_4 —the first members of the paraffine series. Ordinary coal gas, of 16 to 17 candles illuminating power, is of about this composition: Absorbable hydrocarbons, 4 per cent.; carbonic acid, 6 per cent.; hydrogen, 5 per cent.; nitrogen, 2 per cent.; and paraffine, 38 per cent. Richer gases made

from cannel coal generally contain a larger proportion of the absorbable hydrocarbons; but a large percentage of these does not always imply great luminosity. [A specimen was examined containing 17 per cent.; and yet the luminosity was only 25 candles.] Great interest attaches to these hydrocarbons, because in old days it was always thought that the illuminating power might be determined indirectly by analysis. This is now known to be impossible, as the proportion of these hydrocarbons in any gas is no criterion of its luminosity. Coal gas analysis, using glass vessels sealed with mercury, is a difficult operation, requiring considerable skill and knowledge; and the information it gives is somewhat limited. It is unfortunate not to be able to distinguish between a mixture of hydrogen and paraffine, and a mixture of paraffines themselves; but this necessitates treating the remaining hydrocarbons as marsh gas. Pure marsh gas, however, has only a luminosity of 2 candles; and if 4 per cent. of the absorbable hydrocarbons, which are commonly supposed to supply the whole luminosity, are removed, there remains a mixture containing 38 per cent. of marsh gas as expressed by analysis. Consequently, a luminosity of 8 candles has to be accounted for by the presence of 38 per cent. of a gas which in itself only yields the light of 2 candles. It must always be borne in mind, therefore, that marsh gas represents certain unknown paraffines, which in some way add to the luminosity. Still, gas analysis is very useful, and absolutely necessary; and there is no harm in stating the results in this way, provided they are understood. The only danger is that people may run away with the idea that there are no paraffines present under the first section.

As a rule, the carbon shows greater variation than the hydrogen in these hydrocarbons. Benzol and toluol, no doubt, are present to the extent of 0.75 per cent.—sometimes more, sometimes less. Naphthaline which occurs in exceedingly small amount, is very troublesome, as gas saturated in it cannot be cooled without depositing some of it in the crystalline form, in which condition a very slight quantity is sufficient to block up small service pipes, and, in exceptional cases, it may even obstruct the mains. This body is always found among the decomposition products of organic substances when submitted to the action of high temperature. It is also very prominent in gas and tars resulting from the distillation of those coals which yield thick tars with small natural amounts of gas liquor. Newcastle coals and the finest of the South Yorkshire Silkstones are especially prominent in giving much of this troublesome body. Up to the present time no one has been able to remove this substance in the gas works. Coals yielding thin tars do not deposit solid naphthaline in the mains, and absorb but small quantities of a light oil containing some naphthaline in solution. Fortunately, naphthaline never accumulates to such an extent as to necessitate its bodily removal from gas mains; and when it condenses in the service pipes it is usual to blow it back again into the main, and trust to its being picked up by the inflowing gas. Gas made during the daytime, not being artificially cooled, cannot have a lower temperature than that of the atmosphere—in fact, it is generally slightly higher; and on going out into the street mains in the evening, when the temperature is much cooler, there is a tendency to deposit this substance, especially in shallow mains and exposed services. If the gas in the works is saturated with the vapor of any substance, on further cooling it will be deposited; and probably all the substances forming the liquid portion of the tar are represented in the gas, with the exception of those which have been chemically removed by the purifiers. They are not there necessarily to the full extent of their vapor tension at the temperature the gas had at the time it left the tar.

To fully understand this subject it is necessary to study the researches on the question of vapor tension and hydrocarbons, especially the physical properties and constituents of coal gas as regards their liquid and vaporous condition, and their vapor tension under various circumstances of temperature in the presence of each other. The scientific knowledge at present existing on this matter can only be found in memoirs treating on questions connected with the higher branches of chemical theory; the literature of gas manufacture containing no scientific investigation of these points. There must be a gradual deposition of the less volatile bodies forming the tar from the more volatile gaseous ones which form the permanent gas. Gas analysis as carried on by such apparatus as Frankland and Ward's, or Thomas's, or by any mercurial apparatus, is too complicated to be briefly dealt with. In gas works generally an apparatus called Cooper's tube is used, the principal advantage of which is that just what results are desired may be obtained by it. When gas is held in a tube sealed with some liquid not mercury, the liquid generally interferes, by its solvent action, with some of the bodies which are not required to be estimated. Hempel's apparatus is specially designed to get rid of this solvent action; the liquid forming the seal being first saturated before the estimation is made. [A description of the mode of

working this apparatus was then given.] The quantity of gas dealt with is 100 c.c. If there is carbonic acid present the gas is first driven over into a potash pipette which has been used several times. Absorption of the carbonic acid takes place; and then the gas is brought back again, and the loss measured. In the same way, hydrocarbons absorbed by fuming sulphuric acid are dealt with—the carbonic acid being ascertained by absorption in cuprous chloride solution; and arrangements may be made for determining the oxygen, if any should be present, though it ought not to be found in properly made gas. The solution of cuprous chloride will absorb some of the hydrocarbons, ethylene and acetylene, so that these bodies must be removed before the cuprous chloride is used.

The testing of finished coal gas comprises the following estimations: First, a qualitative test for sulphuretted hydrogen. In some places in America this impurity may be left in. The test is exceedingly simple. Bibulous paper, moistened with a 10 per cent. solution of acetate of lead, is submitted to the action of 10 cubic feet of gas; and to make the test more severe, the whole of the gas may be caused to play on one spot on the paper. If the paper is not discolored, the gas is clean. The next is a quantitative one for sulphur compounds other than sulphuretted hydrogen—commonly called carbon disulphide, but really carbon bisulphide *plus* other sulphur compounds. The principle of the method employed for this test is that of burning gas in a small jet with a plentiful supply of air; the whole of the sulphur being oxidized to sulphurous acid. The apparatus is so arranged that the air round the gas jet is charged with ammonia vapor; the object being that when the products are slightly cooled the ammonia shall condense on the glass marbles which fill the vessel, and form a scrubber by which all the sulphurous acid in the gas may be arrested. The gas passing through is measured in a meter constructed to shut itself off after the passing of 10 cubic feet of gas; and the water containing the ammonium sulphate is then collected. It is essential, in order that this test may be accurate, that the air supplied to the burning gas should be as pure as possible. In some gas works it is customary to put the apparatus in any little corner out of the way; and the results obtained are often very gratifying to the manager. The next quantitative test has reference to the presence of ammonia, which is tested by passing the gas through a tube filled with glass beads, and wetted, in which the ammonia is dissolved. This test must be taken before the gas passes into the meter, otherwise the water in the meter would vitiate the result. The quantity of ammonia present is estimated by two standard solutions—one of sulphuric acid of such strength that 100 septems equal 4 grains of free ammonia, and the other an ammonia solution of such a strength that 100 septems equal 1 grain of ammonia. This method can be used by anyone without special skill, only bearing in mind that accurate results are not obtained with new tubes.

The next test is that for illuminating power; and various attempts have been made to accomplish this without direct experiment. At one time it was thought it could be done by ascertaining the specific gravity of the gas. This it was always well to know, and the method of ascertaining it by Schilling's apparatus was pointed out by the lecturer; but it did not give any information as to the illuminating power. Then chemists tried to find a method by which they could calculate the absorbable hydrocarbons into illuminating power; and after this was given up the jet photometer was supposed to provide a means of testing. The idea was that the illuminating power of gas could be found from the length of a given jet of flame. This, however, was not the case. Still, the method was useful when one was acquainted with the instrument. There was found to be a certain relation between flame-length and luminosity; and a good working rule was the following: To compare the flame-length of one gas with another, it is necessary to take equal volumes of each, and reckoning $2\frac{1}{2}$ cubic feet per hour as the standard rate, burn it in a jet photometer, and carefully measure the flame-length. Every inch multiplied by 2 gives the candle power. This is found to hold good with gas having a lighting power ranging from 15 to 26 candles. The proper method, however, of determining the illuminating value of gas is to do it directly. [The method of effecting this by the standard candles was here carefully described, and the Methven screen explained.] For practical purposes, said the lecturer, the latter was much superior to candles, the flame being more convenient, and one reading being sufficient.

After referring to the presence of cyanogen compounds in gas as a subject which called for further investigation the lecturer concluded the course by remarking that he could not say whether coal gas was likely in future to maintain its present position, and stand the assaults of other competitors. This, he thought, must largely depend on those to whom was intrusted the duty of developing the gas industry; and he warned

those who intended devoting themselves to this calling that they must bring to their aid the most powerful weapons which could be obtained from the arsenal of Science—not a cheap and easily acquired quack sort of science, but something which would cost many hours of diligent study and anxious thought. Students must do their best to cultivate habits of accurate observation, so as to be able to correctly interpret what they saw. This habit could only be acquired by severe mental discipline in scientific methods of research. Gifted with the power of correct interpretation, they would be able to unravel many complicated tissues of phenomena; and having done so they would perhaps obtain some results which would be of great value. In this way they would remove forever from the gas industry the last trace of a reproach which (unwittingly, no doubt) was put upon it by its first exponent, Accum; who said: "The manufacture of coal gas requires nothing more than the most ignorant person with any degree of care and attention is competent to perform."

A short description may here be given of the apparatus which Messrs. A. Wright & Co. supplied for illustrating the concluding lecture. First of all mention must be made of their improved dome photometer, arranged on the Lethby-Bunsen principle, but provided with a dark chamber, consisting of curtains, so as to dispense with the darkened room. This photometer is fitted with a gas meter and combined clock of special character, in so far as it includes a method of automatically keeping the clock wound up during the whole time the experiments are in progress. The entire apparatus is of a very unique and chaste design.

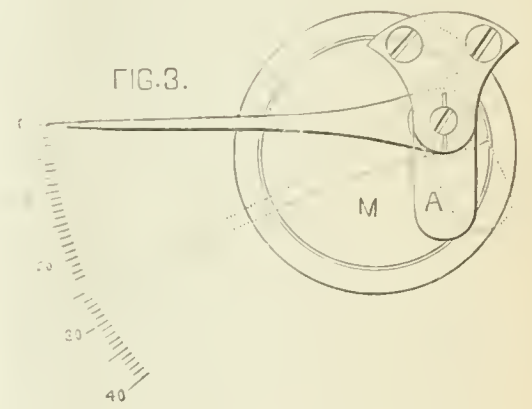
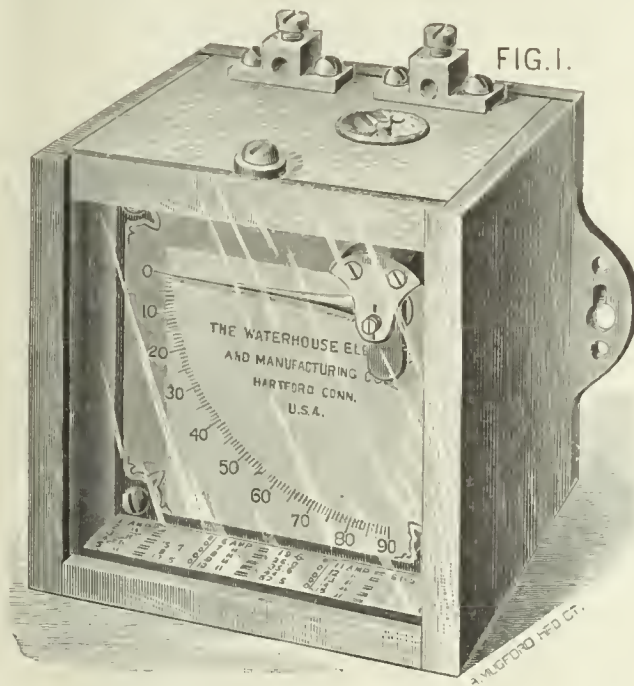
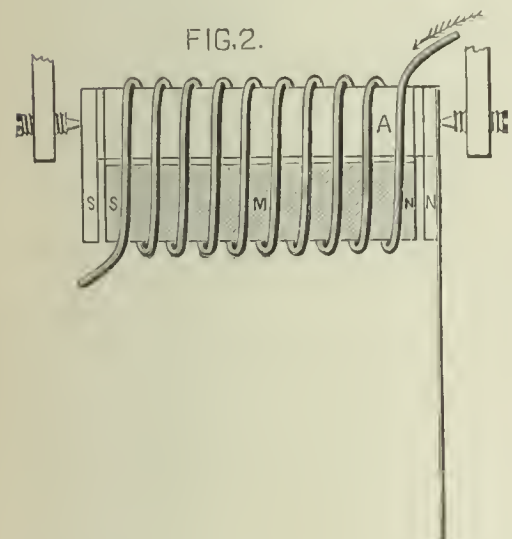

They also furnished a complete set of apparatus for testing for sulphur and ammonia in coal gas according to the "Instructions" of the Metropolitan Gas Referees, in which was included one of Wright's new pattern automatic stop-action meters, and a gas calorimeter, as devised by the late Mr. F. W. Hartley, and shown at the Inventions Exhibition. They likewise supplied one of Wright's new pattern Crossley pressure and exhaust recorders, handsomely finished in Gothic design, the tank being octagonal in form and japanned, and the clock and scale drum inclosed in a crystal case with bronzed metal frame. This recorder comprises several novelties, the object of which is to limit the friction generally entailed in guiding the gasholder and marker. The latter in this case consists of a small glass syphon pen, charged with ink, which is mounted in a light frame having a pendulous action, which can be adjusted so as to permit the marker to bear with very great delicacy against the scale-paper. This marker is suspended by a fine waterproof silk line, which descends from an overhead arrangement of light grooved wheels placed above the clock. The cord is in connection with the gasholder, from which it takes its motion. By arranging the relative diameter of the overhead wheels, any desired and convenient proportion of scale on the drum may be obtained with one and the same gasholder. This arrangement has, we believe, worked most successfully; the friction generally experienced with the Crossley recorders being almost entirely overcome. The instrument is of elegant design, but is at the same time very durable.

The Waterhouse Standard Ammeter.

The advent of a reliable ammeter will be gladly hailed by practical electricians, and the one now about to be placed on the market by the Waterhouse Company seems to merit a close examination. In fact its

manufacturers go so far as to assert that they are convinced that, in the new instrument, the objections common to ammeters hitherto on the market have been overcome.

In a communication descriptive of the "Waterhouse Standard Ammeter," we are told:

The best electrical measuring instruments in use depend for their action upon a permanent magnet, or, in their construction, a coiled spring is used, so that the magnetism of the magnet or the resiliency of the spring is a varying quantity, hence frequent calibration is necessary to correct the noted variations. The object in producing the Waterhouse instrument was to build an ammeter on a new principle intended to cause the action of the same to be unvarying, or so that, when once standardized, its reliability would be lasting.

The Waterhouse instrument is most sensitive to the variations in the current transmitted through it, and is not only adapted for use in electric lighting stations, but also for the finest laboratory tests. A number of these instruments have been in use—and in both of the above mentioned capacities—for some time, and are giving entire satisfaction.

Fig. 1 shows a front view of a finished or completed ammeter—a volt meter is also made on the same principle, besides an ammeter and volt meter combined. On top (Fig 1) are shown the binding posts for circuit wires, and also a small compass for denoting the direction of the current. The front presents a dial with silver indicator, and the floor is occupied by a table on which the calibration of the instrument is recorded. These are inclosed by a glass that is secured in position by a screw and washer at top and in front. The principle involved is displayed in Figs. 2 and

3. Fig. 2 shows a section of the working parts, consisting of a coiled conductor wound around a stationary core, *M*, of soft iron, said core having a longitudinal slot, the latter being situated to the left of the median line of the upper edge of the periphery of the core. In this slot is placed a soft iron armature, *A*, which is provided with iron pendant pole pieces and a silver pointer. The armature, *A*, with its pole pieces and pointer are in reality in one. They are finely pivoted at each end, and are free to swing or vibrate, while the core, *M*, is stationary.

The current in the coiled conductor polarizes each end of *M* and *A* alike, so that the poles attached to *A* are of the same sign as the same ends of *M*. The result is that like poles repel, which causes the pendant parts of *A* to swing away from the center of the core, *M*, as shown in Fig. 3, carrying the pointer (as shown in dotted lines) to an angle corresponding to the intensity of the current passing through the conductor to be measured. Use is made of the repelling power of magnetism for the reason that it is prolonged, and also exerted evenly, whereas that of attraction would be variable. When the current is cut off gravitation carries the pointer back to *O*. The use of the repelling power of magnetism and gravitation for returning the indicator to *O* overcomes the necessity for either a permanent magnet or a coiled spring.

The English Gas Companies and Mineral Oil.

Engineering, in discussing the above, says: "We announced last week that the Russian Government intends holding a petroleum exhibition at St. Petersburg in November, to which foreign manufacturers are invited to send goods. In the meantime we note that the Imperial Russian Technical Society has issued a circular to all the public bodies in Russia, inviting information as to the method of illumination used in

the towns, manufactories, public buildings and private houses of each district, specifying whether electricity, gas, mineral oil, or candles are employed. The information will be interesting, and a similar inquiry set on foot in the United Kingdom might be productive of useful results. Mr. Geo. Livesey, Chairman of the South Metropolitan Gas Company, in a speech to the shareholders a few weeks ago, stated that he did not fear the competition of electricity in the least, but 'gas had a great competitor in petroleum, which was becoming very cheap, and which threatened serious competition.' When the chairman of such a great gas corporation expresses fears of this kind, we may rest assured that gas already feels the rivalry of mineral oil in the metropolis. Nor is the rivalry confined to London only. At the last or Manchester meeting of the Gas Institute the other day the chairman urged that the competition should be met by companies boldly adopting mineral oil as an illuminant, and lending lamps to customers for a small rent, as they now do gas stoves. There is a good deal to be said on behalf of such a scheme. An English gas company has just fitted the Opera House at Vienna with the electric light, and why should not others—as vendors of illuminants—provide people with lamps? A well made and handsome lamp cannot be purchased under half a guinea, particularly if provided with safety appliances, and two or three times that figure is very commonly paid. In Brussels there are companies that lend lamps and trim them daily for a small fee. Why could not gas companies adopt this plan? There is more than one type of safety lamp in the market which will give a light of 43 candles—the equivalent of the ordinary gas-lamp—for less than half the price (2s. 5d. per 1,000 ft.) charged by the South Metropolitan Gas Company for gas. The fact that within little more than a year 300,000 such lamps have been sold, indicates a determination on the part of the public to make use of the cheapest and purest light, particularly when coupled with absolute safety. If gas companies do not adopt the suggestion recently made at Manchester, there would appear to be every probability that the Brussels system will be followed here by special mineral oil companies, and the opposition referred to by Mr. Livesey will become still more formidable."

Compressed Air as a Motive Power.

In mining operations compressed air for several years past has been extensively used underground for the driving of ordinary machinery, and in the construction of tunnels, and that with unquestioned success and economy. Above ground, however, it has certainly not made the progress that might have been expected. Yet the power is the safest there is, can be easily applied, and is more economical than steam for all purposes. Now, however, its value is being recognized, and it is about to be tried on a comparatively large scale for factory machinery and other uses in which steam is now employed. Compressed air, it may be said at starting, is of rather recent date as a motive power. With respect to it, Letters Patent were granted in June, 1856, to Mr. James Atkinson Longridge for "improvements in obtaining and applying motive power for the conveyance of minerals, pumping, and other purposes in mines in which motive power is required." This the patentee proposes to do by the use of compressed air forced into suitable reservoirs by means of a head of water acting on pumps or other apparatus suitable for the purpose. But instead of so obtaining the air by means of a head of water, Mr. Longridge stated that the compressed air might be compressed by an engine or suitable machinery above ground, and then conveyed by pipes to the reservoirs in a mine. This latter system has been adopted at a considerable number of mines, and the drawback in the first instance, caused from the loss of heat through having to work two machines instead of one, was, in a great degree, remedied by improvements in the engines used for the compressors, as well as in the compressors. In the driving of underground machinery the success has been of a marked character, as it has even in a higher degree in the working of coal cutting machines, where the power has been used at long distances from the bottom of the mine shafts. It has also been proved in working that the percentage of power lost in the friction of the pipes which convey the power is less for air at a high pressure than it is at a low pressure, as the power at the lower pressure is so much less portable than at the higher. Then there is the expansive force of the air by the application of heat before it is finally used, which is considered of great importance by those who have studied the application of compressed air as contradistinguished from that of steam power. With respect to this Mr. Longridge, in his specification, says, "After the air is compressed I sometimes further augment its expansive force by the application of heat, and I employ the force of the air so compressed and heated in mines for the purpose of haulage by the use of locomotive engines actuated by such compressed air; or stationary engines actuated by such compressed and

heated air, may be employed in haulage or for other purposes in mines in which motive power is required." As we have before stated, the use of compressed air as a motive power, up to a rather recent period, has been principally confined to mining purposes, the air, as a rule, being compressed at the surface, and sent into the workings by means of pipes. The engines at the bottom, so worked, are and can be put down at any point or place in the intake or in the return airway, so that the air can be exhausted into the roads without any injurious effects whatever—indeed it may be made the means of improving the ventilation of some places by exhausting into the intake airways. But the compressed air is also now being successfully used in the driving of tramcars in Leeds and other large towns, and its extension to our leading manufacturing centers as the motive power instead of steam is now likely to take place, and that on economical grounds more especially. Birmingham has taken the initiatory, and after a year or two's consideration the company there formed has made known the fact that it is now about to put down the necessary plant for compressing air and distributing it—in one district at least to commence with—to those who are users of steam power. This will do away with a good deal of hard and exhausting work, such as stoking, the removal of ashes, etc., whilst there will be no necessity for furnaces and boilers. Leeds, it appears, has obtained the contract for the engines and other appliances, and for these the town has a reputation beyond all others, compressed air material for many years having been employed in and around it for coal cutting machines as well as for other purposes. The engines are to be vertical beam, triple expansion, compound condensers, calculated to produce a maximum of 15,000 horse power: but at first it is proposed to put down some six compressing sets, each one being equal to a thousand-horse power. This will make an excellent commencement, and there is no doubt that such satisfaction by it will be given that the general adoption of the principle will be eagerly sought after by the great body of the manufacturers in Birmingham, followed by those in all other of our leading industrial and producing centers in which motive power is an indispensable factor. In the first instance, however, we are informed that the Birmingham Company intend to supply three of the wards in the town, in which there are 258 steam engines in constant use with 3,588 nominal horse power, most of the engines in use being under 20-horse power. These engines can easily be adapted to the using of air instead of steam, all the other appliances being dispensed with. The area of the Company's district is said to be close upon 1½ mile, and requiring 23 miles of mains. The air is to be compressed to a minimum of 45 pounds to the square inch, or 59.7 absolute. The actual cost of compressed air as compared with steam, leaving out of question the other advantages appertaining to the former, is also such as must lead to its general adoption in all cases where economy is of consequence. The Birmingham Company, in having the air pure before being compressed by careful filtration, and so stored, estimate they will be able to supply it at about £13 per annum for each indicated horse power, as against the existing cost of the general steam horse power average in that town of £17 12s. 8½d.—a saving of more than 20 per cent. The result of the initiative labors of the Birmingham Company, there is no question, will be looked forward to with absorbing interest, not only by the manufacturers of this country, but by those in all parts of the world where steam is used to any extent for productive purposes. A great many of the mine owners at home are fully acquainted with and appreciate the value of compressed air as a motive power for every mining purpose, whilst its value at foreign mines, metalliferous more especially, should lead to its adoption at them as the safest, simplest, and most economical of powers, the easiest stored, and the easiest applied.—*London Mining Journal*.

SPECIAL ENGLISH CORRESPONDENCE.

COMMUNICATED BY NORTON H. HUMPHRYS.

SALISBURY, Sept. 10, 1887.

Mr. W. J. Dibdin on *Photometrical Standards*.—*Gas and the Stage*.—*A New Edition of "Lunge on Coal Tar and Ammonia."*—*A Petroleum Scare*.

Mr. W. J. Dibdin, F.I.C., F.C.S., has just completed an important series of experiments on "Photometrical Standards." He is the superintending gas examiner, as well as the chemist to the Metropolitan Board of Works, and in reporting to his committee some three years since on this subject, he stated the results of certain experiments which he had at that time carried out, as to the possibility of finding something more suitable than the existing legal standard of artificial light in this country—the sperm candle of six to the pound, consuming 120 grains of sperm per hour. For several years it has been known that the candle is of an er-

ratio and contrary nature; to start with, it obstinately refuses to burn at the prescribed rate. Instead of keeping to the straight course of 120 grains per hour, it will persist in careering either to the right or to the left at its own sweet will, so that the operator cannot be sure on commencing whether the candle will burn at the rate of 110 or 130 grains. Such skittish behavior is most undesirable in what should be a staid, straight-up-and-down, rigid, Parliamentary standard, but hitherto the legal authorities have been compelled to say of the sperm candle, "With all thy faults I love thee still," for the simple reason that no system, tried and proved to be better in an all round sense, and therefore worthy of replacing it, was known. Mr. Dibdin, in his report, presented in the early part of 1885, mentioned that his experiments showed that no less than four reliable substitutes for the wayward candle existed—viz., the pentane standard as proposed by Mr. Vernon Harcourt, the Methven screen, the Sugg's 10-candle screen, and the Keates' oil lamp. And his experiments also agree with those of previous investigators in showing that, even if the sperm candle does by any chance happen to burn "according to contract," the actual amount of light yielded is not constant. This is a serious indictment. If the sperm candle will not give a fixed and rigid quantity of light per grain of sperm consumed, then it is not fit for its present exalted position, and it must be politely requested to take a back seat. For the chief axiom in the system of light measurement by the medium of the candle is the assumption that the weight of sperm used is in direct proportion to the amount of light afforded. In the report in question, Mr. Dibdin mentioned certain directions in which the apparatus at his command was incomplete and unsuited for comparative experiments with three or four different sources of light, and recommended that a series of tests should be carried out with a fourway photometer for the purpose of determining, under conditions beyond all question, which of these various systems would give in practical working the most uniform results, and the nearest approximation to the standard sperm candle. This recommendation was accepted, and he was authorized to procure such special apparatus as was necessary. Accordingly a room was specially fitted up, and a fourway photometer constructed for the occasion by Messrs. W. Sugg & Co., with every known improvement. With this apparatus a series embracing no less than 2,100 experiments, representing ten times that number of actual observations, has been carried out, under the superintendence of Mr. Dibdin, by gentlemen selected from the London gas examiners, and consequently experienced photometrists. The result of these researches which have been so carefully conducted with every possible precaution, that the probability of their being questioned is very remote, is to show that the previous bad character given to the candle is by no means undeserved. It stands last on the list, with the Keates' oil lamp in close conjunction to it. The apparatus that has most successfully passed this searching ordeal is the pentane air gas, known after the name of the inventor as the "Harcourt standard." But the "screens" proposed by Mr. Sugg and Mr. Methven follow very closely behind, and, indeed, show out very creditably as reliable standards of light. The Hefner-Alteneck lamp, which consumes amyl-acetate, gives very good results, but the color is considered objectionable. Experiments were also tried with other less known systems that have been suggested, but these have little practical importance in connection with the practical valuation of coal gas.

At the moment I am writing comes the news of another awful catastrophe in a theater. At 10 o'clock one evening this week the Exeter theater was filled with an interested audience of some 800 persons, witnessing the performance of a new play. In another half hour the scene had changed for one whose horrors defy description. The scenery rolled up above the stage by some means became well ignited before it was observed, and the performers rushed out in alarm, having first lowered the curtain. They were surrounded with flame before they knew it. A large door at the back of the stage was left open, and the draught carried the flame through into the upper part of the auditorium. The occupants in the pit, stalls, etc., escaped, but the ill-fated people in the gallery were overpowered and destroyed. The building was literally devoured by the flames in the course of an hour or so, and the morning sun rose upon a mass of smoking ruins that included the charred remains of nearly 100 human beings, mostly mangled and burned beyond recognition, whilst a number of corpses sufficient to bring up the death roll to 200 had been removed to neighboring houses. In many cases a watch or other trinket found in the ruins is all that remains to convey the sad tale to a sorrowing household. The awfulness of the catastrophe may well excuse my dwelling for a moment upon its horrors, though the reason for mentioning it here is to consider the result of this disaster, following so closely upon two others of a similar nature, as regards the use of gas in theaters. Electricians have not failed to take advantage of the popular excitement which followed the fires at Paris and New York,

with a view of securing the adoption of the electric light in these places of entertainment. It has yet to be proved that by this means immunity from fire can be secured, for conflagrations have already been caused by electric lighting wires, notwithstanding the very limited extent to which they are used. But it is evident that, with the elaborate effects and the numerous changes of scenery that have now become usual in modern theaters, the system and mode of lighting theatrical stages as usually adopted must be thoroughly overhauled. The theater in question was a handsome modern building, designed by a prominent London architect, and despite rumors to the contrary, I see no reason for believing it to be deficient in exit capacity. It is little better than a delusion to talk about "more exits than one," and making wider passages, etc., for the more rapid emptying of the house in case of accident. When people see a body of flame bursting through the act drop they will not form themselves into companies like a regiment of soldiers, each company leaving by its special entrance in good marching order. No; there is a stampede, some one falls; there is a general block * * * my friends at Exeter can describe the rest. Prevention is better than cure, and the lights used should be inclosed in cases so that there is no risk of the "flies" blowing against the miserable wire globes which are called a protection(?) to the gas burner. The heated products of combustion must be removed and not allowed to come in contact, possibly at a distance of a few feet above the flame, with closely packed rolls of canvas scenery, painted in oil or other inflammable mediums. I learn that the Exeter stage was closely packed with scenery. So long as large quantities of gas are consumed on stages "closely packed with scenery," with no provision for preventing the heated products of combustion from coming in contact with the same, so long will there be the risk of conflagration. It is not impossible to light a stage with absolute safety by means of gas. If closed lamps of the regenerative type, such as Sugg's, Wenham, Lungren, and other well-known makes, had been in use at the Exeter theater probably the sad accident I am now recording would not have happened. Lamps of this kind would also assist the ventilation of the building, providing the exit flues were properly disposed. Indeed a plan on this principle is very generally adopted for the footlights, so as to prevent any risk of a performer's dress catching fire.

A new edition of Prof. Lunge's well-known work on "Coal Tar and Ammonia" has been issued. Just five years ago the first edition came out, and now the author has extended his ground. The earlier work treated of distillation only in connection with these substances, but it has now been expanded into a general treatise. It is doubled, both in respect of letterpress and engravings, and may be commended as containing a vast amount of information as to the sources of coal tar and ammonia, the quantity produced, the various purposes for which they are in demand, and generally as treating of the commercial and financial, as well as of the scientific and technical, parts of the question. In view of the recent variations in the market, and the important effect thus produced on the finances of gas undertakings, this work possesses special interest. I observe that Prof. Lunge agrees with the plan first suggested by Mr. G. Livesey and since adopted at many gas works, of burning a considerable proportion of the total quantity produced as fuel on the works, with a view of diminishing the quantity thrown on the market, and thus raising prices.

Some gas people are feeling themselves disquieted about cheap petroleum, which, it is rumored, is to be brought from the neighborhood of the Caspian Sea, and retailed in London for 3½d., and in Bristol for 6d. per gallon (it may be in Bristol for 3½d. and 6d. in London, I am not quite sure), and in more inland places at proportionately cheap rates. Petroleum certainly seems to be springing up all around us, and every mail, almost, brings intelligence of its being discovered somewhere or other where it was never known before. If "prospecting" is going to continue at this rate the earth will soon be dotted all over with borings like a worm-caten plank. But I see several rays of comfort for the nervous ones. When the electric light was first introduced someone hailing from the stars and stripes side of the Atlantic very pertinently put the question, "Is it come to stop?" and I think we may say the same as regards petroleum. There are rumors that some of the best wells in the States are gradually failing, and that their yield is growing smaller by degrees and beautifully less. No doubt there remain plenty of fresh fields to be worked, so that a bountiful supply can be depended upon. There is no reason to think that petroleum is going to be used up. But living costs money, and anyone that has gone to the expense of making a well will not be inclined to give away the yield for next to nothing if he is doubtful as to how long it is going to last. He will want to make hay while the sun shines. Another thing, and that is the fact that in the States it seems that coal gas undertakings yet manage to keep alive, even with a petroleum field as a neighbor on one side, and a natural gas

blower on the other. So I am not inclined to despair as to the future of the English gas industry. It can hold its own against the field. But gas engineers will have to advance with the times, and take advantage of every possible means that offers for cheapening the price of gas.

ITEMS OF INTEREST FROM VARIOUS LOCALITIES.

DEATH OF A FRENCH GAS ENGINEER.—M. Leonce Vee, who was a prominent figure in French gas circles for many years, died on the 29th of August. M. Vee, who had reached the age of 50, was an ex-Treasurer and ex-Vice-President of the French Association of Gas Managers.

ELECTRIC LIGHT FOR THE BUREAU OF PRINTING AND ENGRAVING.—It is understood that the favorable report returned by the experts, to whom was referred the subject of lighting the rooms in the building occupied by the Bureau of Printing and engraving (Washington, D. C.), has been approved by Acting Secretary Thompson, of the Treasury Department, whose assent virtually makes the contract. It is estimated that 1,000 lights will be necessary to illuminate the place satisfactorily. The chief argument advanced in favor of the substitution of electricity for gas was based on the "excessive heat" developed by the latter. The Bureau interior is a model specimen of the architectural efforts of the dark ages, hence artificial illumination must be resorted to at most unlikely hours.

NEW GAS COMPANY.—A gas works is to be constructed at a point between the villages of Palmer and Monson, Mass. These places are something like 15 miles east of Springfield, and the Chicopee river constitutes the northern boundary line of Monson. The population of the two villages probably numbers 6,000.

PUBLIC LIGHTING AT SAN ANTONIO, TEXAS.—It is quite a difficult matter to say positively whether or not the action—to all intents and purposes binding and final—of city councils can be accepted as settling a contract, for we have been altogether too frequently treated to examples which proved nothing or everything. With that understanding of the eccentricity of the rulings of city fathers in general, we herewith chronicle the fact that the San Antonio City Council has authorized the local Gas Company to maintain a mixed public lighting service, in accordance with the following: 50 arc lights (2,000-candle power) at \$14.40 each per month, and 200 gas lamps, at \$2 each per month. We hope that this action ends the San Antonio street lighting squabble, and congratulate the local gas men on the result.

SUCCESSFUL IN ANY EVENT.—Mr. R. D. Wirt, who is President of the Independence (Mo.) Natural Gas and Coal Company, is quite elated over the "find" made by drillers in the Company's employ who are now engaged in the attempt to extract natural gas from the bowels of the Sheley farm, which plot is about one mile distant from the town. On the 12th inst. the drills passed through two veins of good bituminous coal, the first being encountered at a depth of 459 feet, while the second was pierced at a depth of 465 feet. The first vein is four feet thick, the second being 3 feet 6 inches. Although Mr. Wirt confesses that natural gas (the prime object of his search) has not yet been developed in anything like paying volume on the Sheley property, he is far from being discouraged at the outlook, because the drills have not yet (Sept. 14) gone below 500 feet. In any event those coal seams will go far towards consoling him should the gas field ultimately prove barren.

AN AGENCY DISSOLVED.—Messrs. F. R. Buell & Co., who for some time past have acted as agents at Milwaukee, Wis., for the sale of the gas coal mined by the Monongahela and Peters Creek Gas Coal Company, are no longer to act in that capacity.

CONCERNING THE CHICAGO (ILL.) GAS BONDS.—Some time ago we intimated that an important issue of bonds was about to be made by those now in control of the gas supply of Chicago, and, although a weak denial of the intimation was circulated shortly thereafter, it is nevertheless a fact that the bonds are now on the market. The following statement concerning the issue appeared in the Chicago *Tribune*, dated Sept. 17th: "The trust deed securing the proposed issue of \$10,000,000 gold bonds by the Gas Light and Coke Company, although not yet entered of record, has been printed, and contains a good deal that is of interest to investors. The mortgage authorizes an issue of \$10,000,000, of which \$7,650,000 will be placed immediately, the remaining \$2,350,000 to be emitted from time to time as needed for improvements and extensions, the amounts so issued never to exceed 90 per cent. of the cost of the improvements. The instrument is dated July 1, 1887, and the bonds are 5 per cent. gold

bonds, in \$1,000 each, maturing July 1, 1937. Interest is payable on Jan. 1 and July 1, at the office of the Central Trust Company, New York city. The Trustee under the mortgage is the Fidelity Insurance, Trust and Safe Deposit Company, of Philadelphia. In case there should be default for 6 months on the interest, the mortgage provides that the principal shall be declared due, and the property come into possession of the bondholders. The security pledged consists of all the property of the Gas Company, including its franchise, real estate, mains, etc. But why should the old Gas Company issue bonds at all? That is the question now being asked by investors. It is answered in the mortgage thus: 'For payment for property already acquired, for payment for property to be acquired, and for improving, enlarging, extending, developing, and equipping and completing the works of the Company.' Two inferences are deducible from this language: The Company owns property not fully paid for, and it contemplates outlays on extensions and betterments. While it is not known that the Company has any floating debt to be wiped out by the bonds, it is said, and pretty generally believed, that the cost value of its property is more than twice the face of its stock—\$5,000,000. The construction account, it is said by people who have seen the books, foots up a big sum, the total cost of all the property having been about \$13,500,000, which makes the property account \$8,500,000 in excess of the capital stock, and undoubtedly forms the basis for part of the issue of bonds. Friends of the Company say, however, that the bulk of the bonds will be devoted to improvements and extensions. It is said that great changes are in contemplation, that the plant is to be improved so as to produce a better quality of gas, and that extensions in many directions are proposed. The Company already has 250 miles of mains and 27,000 consumers. Its output so far this year has been between 25 and 30 per cent. larger than in the corresponding period of 1886, and its net earnings for 1887, it is estimated, will be nearly \$900,000. As stated in yesterday's *Tribune*, Messrs. Drexel & Co. have taken \$3,650,000 of the bonds; but it appears that they did not get the securities at the low figure named. They paid an even 95, and agreed not to place any of the bonds on the market for 6 months. The remaining \$4,000,000 are now being negotiated, with a probability that they will very shortly be placed abroad at 95." The above ought to cause food for thought in the craniums of those who parted with their stock to the Philadelphia syndicate at a price little in excess of that paid by an eminent and ancient financier, whose peculiar penchant led him to dicker for birthrights. The seller got the pottage, but the buyer kept the pot.

WILL MARYSVILLE, OHIO, HAVE A GAS WORKS?—Some of the residents of Marysville want a gas works, while others say that such an innovation shall never transpire. In the meantime the Village Clerk, Mr. J. C. Guthrie, is receiving bids for the construction of a works, and the malcontents propose to invoke the law in order to compel him to desist from carrying out the wishes of the innovators. Marysville is the capital of Union county, Ohio, and the stream known as Mill Creek passes through or by it. It is located on the Railroad that connects Delaware with Springfield, being 17 miles west-southwest of the former city and 28 miles northwest of Columbus.

PUBLIC LIGHTING AT HELENA, MONTANA.—In compliance with a request from the City Council to bid on the public lighting, the Helena Gas Company offered to place and maintain on the streets 125 gas lamps, in consideration of the annual receipt of \$30 for each lamp, that figure to be reduced in accordance with any material reduction made in the local charge for coal. The Helena Steam Power and Lighting Company offered to maintain 25 arc lights, provided the city would agree to pay \$20 per lamp per month. These propositions did not enthuse the Councilmanic heart to any great extent. It was agreed that re-advertising for bids would be the proper move under the circumstances, because the gas bids were too high, although they were decidedly cheap when placed in comparison with "the exorbitant demands of the electricians." Councilman Howey suggested that a bill recently passed by the local legislature would enable them to solve the whole problem, for under its tenets the city could erect a lighting plant and thus supply its every lighting need "at cost price." Another solon hinted that delay would not be dangerous on this occasion, for another lighting company was anxious to enter the field, and that that entrance would speedily be made, provided its projectors were assured of a slice of the city's patronage. The debate terminated in the passage of the following order: "That the Lighting Committee advertise for proposals to furnish light to the city of Helena, either by electricity or gas, the former to be supplied from not less than 25, and the latter from not less than 125, lamps—the city to elect which shall be adopted—said committee eventually to report all proceedings in connection with their investigation and action at a stated meeting of the

Council." The \$30 per annum gas rate in Helena would perhaps equal a \$22 rate in this section of the country.

CHEAPER GAS FOR ELIZABETHTOWN, N. J.—We are indebted to Mr. F. A. Price, Secretary of the Elizabethtown Gas Light Company, for the information that from and after the 1st. inst. gas is to be supplied at the rate of \$1.75 per thousand cubic feet. When it is understood that \$2.50 per thousand was formerly charged our readers will concur in the belief that the Elizabethtown gas men mean business.

BROTHER GWYNN IS AT IT AGAIN.—A few months (perhaps it was only weeks) ago we published the news that the North Western Ohio Natural Gas Company, of Fostoria, had put in force a new schedule of gas selling rates, the said schedule showing figures much lower than those that preceded them. Not satisfied with the first concession, and seeing the way clear to take a further step in the same direction, the Company, on Aug. 30, sent out the following circular to the Fostorians: "On and after Sept. 1 rates for illuminating gas (manufactured) will be as follows:

Monthly Consumption.	Price per 1,000.
Less than 2,000 cu. ft.	\$1.77
2,000 to 4,000 "	1.61
4,000 to 10,000 "	1.33
Over 10,000 "	1.11

"The above rates will be subject to the usual discount of 10 per cent. if the bills are paid on or before the 10th of each month." This would seem to justify the advice given by Supt. J. Gwynn to his employers, for there is no doubt that he was the prime mover of the proposition to introduce the McKay-Critchlow process at the Fostoria plant of the North Western Company.

TO BRING THE SUIT.—Following up our report of the outrageous manner with which the Fort Madison (Iowa) Company was treated by the local authorities, we can now say that the Company has entered a suit for damages (laid at \$10,000) against the city. The case is to be tried at the District Court now in session in Keokuk.

NEW STATION METERS.—The American Meter Company is under contract to furnish 4-ft. station meters to the gas plants located at White Plains and Rye and Portchester, N. Y.

A GREAT SUCCESS.—The projected illumination (outlined in our last issue) of certain St. Paul streets, during the continuance of the State Fair, has since been practically carried out, and with results that far exceeded the most extravagant hopes of its promoters.

ANNUAL ELECTION, EAST PORTLAND, OREGON.—At the annual meeting (held Sept. 18) of the stockholders of the East Portland Gas Light Company the following officers were elected: President, Jos. Paquet; Secretary, C. B. Bellinger; Treasurer, Jos. Burkhard; Directors, J. Burkhard, J. L. Sperry, J. Paquet, Chas. Logns, and A. J. Knott. The annual reports show that the affairs of the Company are in good shape, and that business is steadily progressing. Contractors might do well to note that extensive improvements will shortly be made on the East Portland plant.

SUMTER (S. C.) TO BE LIGHTED BY ELECTRICITY.—The Town Council of Sumter has closed a contract with Mr. J. H. Furman, General Manager of the Maryland Electric Manufacturing Company, of Baltimore, for the erection of an electric plant to light the town's streets. The contract calls for 10 arc lamps, to be placed at the discretion of the Council; the plant to be in operation by Mar. 1, 1888, and Furman is granted an exclusive privilege for 5 years from that date. By-the way, why would Sumter not be a good point to locate a gas works in?

DESTROYED.—A despatch, by way of Peoria, Ills., dated Sept. 19, says: "The electric light station at Pekin, Ills., was destroyed by fire this morning. The accident will put the city in darkness, since the station furnished the current to the public lamps. Loss on building and machinery, \$6,000; no insurance."

ABSORBED.—A letter from Findlay, Ohio, dated Sept. 20, conveys the information that the City Gas Company purchased the plant and franchises of the old Findlay Gas Light Company, the price paid therefor being \$75,000 in specially issued city bonds. That action places the authorities in absolute control of the gas business of the city.

THE LAW AS IT STANDS.—Now that the charter under which the Louisville (Ky.) Gas Light Company operates is, by limitation, fast closing in its race with time, perhaps the letter of the law giving the city

the right to purchase the gas works may have some interest for our readers. The "option act" is as follows: "Section 19, Chapter 1179, Acts of the General Assembly of the Commonwealth of Kentucky. Approved Jan. 30, 1867. The City of Louisville, if it so elect, may purchase the gas works at the termination of this charter at a fair estimation of what said works are worth at the time; *Provided*, That the city shall notify the Company of said election on her part at least one year before the termination of this charter—the value of the works to be ascertained by two competent engineers, selected, one by each of the parties, and, in case of their disagreeing, by an umpire whom they may select; the proceeds of which sale is to be divided *pro rata* among the stockholders, including the city of Louisville. This charter is to be valid and in full force when accepted by those who hold the majority of the shares of stock in the present Company; and the new company shall become successors to and owners of all real estate and other property belonging to the old Company."

EXTENDING THE MAIN SYSTEM.—Brother Jenks evidently thinks that gas is going to hold its own yet awhile with other illuminating agents now and likely to be furnished within the precincts of the quaint and pleasing borough of Woonsocket, R. I., for we note that he is taking up a two-inch main at the northerly end of Grove street and replacing it with a three-inch one. The latter-sized pipe will be laid on Carrington avenue, from Grove street, running easterly, and also extended down Grove street to Willow street, and at its junction with Grove to Park avenue.

NEW ELECTRIC LIGHT COMPANIES.—The Oneonta and the Catskill Electric Light and Power Companies (both to operate in New York State) have been incorporated. Capital stock in the former, \$15,000; in the latter, \$20,000.

TO FURNISH ELECTRIC LIGHT, TOO.—Mr. Wm. Thorupson, Supt. of the Reno (Nevada) Gas Light Company, writes: "Our Company will, early in the coming spring, put in an electric plant in connection with the gas works. The power will be furnished by steam, and the lights will be of the best. Every effort will be made to supply either gas or electric light to our patrons at the lowest possible rates compatible with efficient service."

ABOUT THE SACRAMENTO (CAL.) GAS COMPANY.—Sacramento has no reason to complain about the quality of the public spirit that pervades those in charge of her artificial lighting supply, even though, through force of circumstance, consumers are called upon to pay the seemingly high figure of \$3 per thousand cu. ft. The Sacramento works were constructed in 1854, and are located on a plot of land (on Front and T streets) having the dimension of 300 by 400 feet, which insures plenty of room for further extensions. In fact an extensive system of plant betterment is now being carried out. The Sacramento gas men also operate an electric plant, and thus are enabled to meet the wishes of the residents in respect of a mixed system of public lighting. The city now maintains about 250 public gas lamps, together with 36 arc lights, the latter being suspended on poles varying from 60 to 150 feet in height. The business of the Company is in every way satisfactory to those in control of its operations.

YAZOO CITY, Mississippi, residents are clamoring for street lamps. Perhaps they are ready to support a gas company.

GREENVILLE (MISS.) is to have a gas company, for, at a recent session of the City Council, a contract was made between the authorities and Messrs. Archer Harmon, H. D. Fitch and S. W. Ferguson—who have incorporated the Greenville Gas Light Company—which binds the city to maintain at least 75 public lights, and to pay therefor the sum of \$2.50 per light per month. The contract is to remain in force for 25 years. Greenville is the capital of Washington county, Miss., and is located on the Mississippi river, at a point about 100 miles northwest of Jackson. It is quite a small place, but has good possibilities in sight.

FRANCHISE ALLOWED.—We understand that the Board of Trustees of the Town of Lake, Ills., have granted the franchise asked for by the projectors of the Economic Light and Heat Company. The Company was placed under \$50,000 bonds to guard the town against any damages that may be secured against the town by reason of the grant—this matter was alluded to in our last issue. We think that the present gas suppliers have a pretty good title to the territory in dispute, and believe that the town, in case the Economic projectors really intend to compete with those now in possession of the Lake gas field, will have reason to call upon the above-mentioned \$50,000 "bond guarantee."

TO PUT IN AN ELECTRIC PLANT.—At a recent meeting of the Jackson (Tenn.) City Council, a proposition made by the Citizens Gas Light Company, to at once establish an electric light plant, in order that the city might be partly lighted by electricity, was accepted. The Gas Company agreed to maintain 25 arc lights (a moon-table to be followed) for the sum of \$2,000 per annum. [For more complete information, see below.]

CHEAPER GAS FOR KEOKUK, IOWA.—The proprietors of the Keokuk Gas Company have again notified their consumers of a reduction in selling rates. The gross price (\$2 per thousand) remains as before, but the discount granted those who pay promptly, or within ten days from presentation of accounts, is increased to 20 per cent. This is equivalent to a reduction of 20 cents per thousand, and affords pleasant testimony about the earnestness of those in charge of the gas supply to deal in a liberal and public-spirited manner with their customers.

LIGHT FOR GRAND ISLAND, NEB.—Some months ago we announced that a gas company had been organized in Grand Island. Now we can say that the works were put in duty on September 19th. The plant represents an investment of about \$65,000.

ASSIGNED.—We note that recent Carthage (Ills.) advices chronicle the demise of the Warsaw Electric Light Company, the proprietors whereof made an assignment to G. J. Rogers, on the 19th ult. The liabilities are less (not much, though) than \$5,000. It is said that operations will not be renewed.

PUBLIC LIGHTING AT WASHINGTON, IND.—At a recent meeting of the Washington City Council the authorities ordered that a contract (to comprise 86 gas lamps, at \$22.50 per post per annum, and 10 arc lights, at \$8 each per month) for public lighting be at once entered into with the Washington Gas and Electric Light Company.

REPORTED ADVERSELY.—A proposal to purchase or lease the plant of the Middletown (O.) Gas Light Company has been considered by the Lighting Committee of the City Council. The investigators finally reported against the proposition, and that adverse action has been ratified by the Council.

COLUMBUS (GA.) TO HAVE ELECTRIC LIGHTS.—The Columbus authorities have awarded a partial contract for the public lighting of that city to the Brush Electric Light Company. Seventeen arcs are to be employed, and the price agreed upon was \$108 each per annum. The lights are to be strung over Broad and Randolph streets.

THE COMBINATION PLAN AT JACKSON, TENN.—Jackson insisted on having arc street lighting, and the local Gas Company thought it should have a chance to supply the same. A proposition submitted by the latter, in which it agreed to put in an electric plant at once, was accepted by the Council, who ordered that the city bind itself to take 25 arcs (to be lighted in accordance with a moon-table) and pay therefor the sum of \$2,000 per annum. The contract is to last for five years, and the Gas Company has pledged itself to turn on the current in time for the Christmas holidays—or nights.

SEND FOR A COPY.—The Combination Gas Machine Company, whose home office is in Detroit, Mich., manufactures many specialties that appeal forcibly to the gas maker. The Company is circulating a handsome catalogue descriptive of the wares sought to be disposed of, and a postal card sent to the Company's address will insure the receipt of a copy of the catalogue at the home of the inquirer.

OTHER METERS UNDERWAY.—Elsewhere we mention two station meters now being constructed by the American Meter Company. To complete the list we add the following:

Dimension, inches.	Name of Company.
60 × 60.....	Grand Forks, Dak. Ter.
96 × 96.....	Utica, N. Y.
60 × 60.....	Vancouver, Brit. Col.
126 × 126.....	Birmingham, Ala.

WILL THEY SUCCEED?—Cleveland, Ohio, is favored with a Gas Company that has acted throughout its corporate life in accordance with the principles of honesty and fair dealing; but many a time and oft the gas field of that city has attracted the attention of those who hate to see others in the undisputed possession of a prosperous business. So far, however, the adventurers have met with slight success in their attempts at dividing the said territory, but the defeats of the past do not seem to exert a positively deterring influence on the desires of newcomers who, in their eagerness to "do" overlook the likelihood that to "die"—in their grabbing attempt—will be their ultimate portion. The aspirants for a

gas charter for Cleveland appeared about a fortnight ago before the Council, and begged that body to pass an ordinance which would give life to the "Cleveland Fuel, Power and Lighting Company." The petitioners pledge themselves to supply gas for illuminating purposes at a charge not to exceed 90 cents per thousand cu. ft. to ordinary consumers, while the city "and manufacturers are to be supplied at 10 per cent. less." The petition was referred to the Board of Improvements. We are inclined to believe that Cleveland is not particularly anxious for the establishment of another gas company.

AN ELECTRIC PLANT.—It is proposed to establish an electric plant, at Olcott Falls, on the Connecticut river, for the purpose of lighting the towns of Hanover, Lebanon, West Lebanon and White River Junction, in New Hampshire, and Hartford, in Vermont.

GAS WORKS are being constructed at Ogden, Cal. It is quite a small place.

OTHER NEW GAS COMPANIES.—The Collinsville (Ills.) Gas and Water Company has been incorporated by Messrs. O. B. Wilson, Wm. Stearns, and H. S. Merrell. This place is a post village of Madison county, Ills., on the St. Louis, Vandalia and Terre Haute Railroad, and is 12 miles east-northeast of St. Louis, Mo. It is also announced that the proprietors of the old East New York Gas Light Company (it is now called the Union Company) intend to extend their pipe system to the town of Woodhaven, L. I., which place is about midway of East New York and Jamaica. They have, however, seemingly organized a separate Company. A Company to supply Black River Falls, Wis., has been formed by Messrs. T. B. Mills, W. R. O'Hearn, and H. B. Cole. This place is the capital of Jackson county, Wis., is on the Black river, and also on the West Wisconsin Railroad, at a point 127 miles north-north-west of Madison, or 55 miles southeast of Eau Claire. There is an abundance of water power in the vicinity, and several flourishing saw and flour mills make it a busy spot. While it is rapidly growing in importance, the present population is not in excess of 3,000 souls. The right to erect a gas works at Anniston, Ala., has been granted to Messrs. T. G. Foster & Co., of Montgomery, Ala. Anniston is in Calhoun county, Ala., on the old line of the Selma, Rome and Dalton Railroad, at a point 14 miles south-west of Jacksonville. Great deposits of iron ore are there found.

THE SLOPER PATENT SUFFERERS.—A recent issue of the Philadelphia *Record* contained the following. By the way, it might be hinted that Sloper, so far at least, has failed to revolutionize the process of gas making; he promised to do so shortly after receiving the parchment from the Patent Office that guaranteed protection to the evolutions of his genius. The *Record* said: "As joint owners of an option to purchase the territorial rights for the State of Pennsylvania of a patent granted to Byron Sloper for the manufacture of illuminating gas, Chas. W. Kreim and Edward Hoffman brought suits recently against the patentee and D. F. Hamlink. The plaintiffs say they paid to Sloper \$750 for the option, and that they have since expended \$500 on the faith of representations contained in a pamphlet relative to the cost and quality of the gas, which, it is now alleged, were false. Bail was allowed by Judge Reed in \$2,500." Moral: Put not your trust in pamphlets.

MORE PATENT APPARATUS.—A certificate incorporating the Archer Gas and Fuel Company has been filed with the State Secretary of Indiana, which proposes to operate at Terre Haute. The capital stock is placed at \$500,000, and the business of the concern is to be the manufacture of patent apparatus for the production of gas. The Directors are Messrs. N. K. Elliott, W. Kedder, J. G. Williams, A. J. Crawford, J. A. Wildman, and J. R. Kendall.

ANNUAL REPORT, JAMAICA PLAIN (MASS.) GAS LIGHT COMPANY.—We are indebted to Mr. John C. Pratt, President of the Jamaica Plain Gas Light Company, for a copy of the 32d Annual Report of that corporation to its shareholders. This time the report—in order to comply with the regulation of the State Gas Commission ordering that the fiscal year is to terminate on the last day of June in each year—embraces a period of 15 months; and from it we learn that the Company received the sum of \$68,015.75, while the expenditures footed up \$45,528.85. This shows a net profit (for the 15 months) of \$22,486.90, out of which two dividends (4 per cent. each), amounting to \$16,000, were paid. The balance (\$6,486.90) was credited to surplus, that account now standing at \$43,172.20. The Company's proportion of the Gas Commission expense was \$263.48. In the summary President Pratt says: "The foregoing statement shows the net earnings of the Company to have been \$22,486.90. The net earnings for twelve months were \$20,004.38, against \$17,922.31 for the previous twelve months, showing a gain

of \$2,082.07. The Directors have commenced the extension of their mains into the village of Roslindale, and will the present season lay about 25,000 feet of pipe. The rapid growth of this part of the ward affords good ground for the hope that this may prove a profitable investment. To pay the expense of this extension, and the plot on South street, purchased for the erection of a gasholder whenever it shall be required for that district, the Directors have negotiated a loan of \$20,000, to run for 10 years, at 4½ per cent. interest, deeming that course preferable to the issue of stock. Our surplus (\$43,172.20) is represented by the cost of enlarging and rebuilding our works in 1883—amounting to \$43,886.11—for which the Company has the right at any time to issue stock and divide the same among the stockholders. The works of the Company in every department are in excellent condition, and, so far as practicable, no depreciation is allowed to take place. The following statistics are appended: Gas made in 15 months (April 1, 1886, to June 30, 1887), 34,126,400 cu. ft.; coal carbonized, 3,294 tons; candle power of gas, 18; coke sold, 1,777 chaldrons—being 57 per cent. of the quantity made; meters in use, 947; street lights, 569." Evidently Mr. Pratt's executive ability is as staunch and sound as ever; and long may it continue so to be.

Marsault's Coal Washer.

The *Colliery Guardian*, in detailing the construction and operation of Marsault's coal washer, explains that the body of this machine consists of a large tank 6 feet x 10 feet x 24 feet deep, open at the top, and with sliding doors in the bottom, by means of which the sluices may be discharged without stopping the action of the machine. Above the tank an inverted cylinder is fixed, to the piston-rod of which is attached an iron cage 10 feet in height. The ends of this cage are left entirely open, the bottom being formed of an ordinary coal washing sieve; on the closed sheet iron sides there are fixed, one above another, a series of horizontal ledges, on which slide three rectangular wooden frames, fitting loosely within the cage, and made like drawers without bottoms, the depth of each frame being determined by the nature of the coal to be washed. This cage slides between guides, which are fixed from the top to the bottom of the washing tank, between the slides of which and the cage there is a clearance of space of less than ¼ inch.

The tank being filled with water, and the cage fixed up in the top of the tank by means of bolts at the sides, a charge of from 3 to 5 tons is let fall into the cage from a chute placed over the machine at a height above the top of the tank determined so as to insure the whole of the stuff becoming at once thoroughly soaked by falling into the water in the tank.

In order to equalize the distribution of the charge over the whole of its area, the loaded cage is first subjected to two or three jigs of considerable height, after which it is allowed to fall to the bottom of the tank by a regular succession of short drops, adjusted beforehand to suit the size of the stuff treated, and this height is capable of being varied as circumstances may require, from ¾ inch to 8 inches, by regulating the escape of the water from the hydraulic cylinder from which the cage is suspended.

At each drop of the cage the water passes through the sieve in the upward direction at a speed due to the restricted area of passage and the relative weight of the immersed cage with its load, and the mass of stuff in the cage is thereby lifted off the sieve, or rather the sieve drops away from beneath it, while the charge remains momentarily at rest; then all the separate particles of the charge fall severally through the still water with their own individual limiting velocities, modified only by their mutual interference, as in all other washers. With a charge of 4 ft. to 4 ft. 3 in. in thickness in the cage, a total broken fall of 10 ft. to 13 ft. through the water is generally sufficient; if, however, the tank should not be deep enough, or the sorting not perfect, the fall can be repeated with the same charge as many times as may be necessary.

On the cage reaching the bottom of the tank a few seconds pause is made to allow the largest of the minute light particles, which have not fallen so fast as the rest, to become deposited upon the charge. The cage is then drawn up out of the water and fixed in position by the side bolts, the three sliding frames successively pushed out at the front by the action of a horizontal hydraulic cylinder placed behind them, and by these means the washed coal, the stuff to be rewashed, and the shale are each discharged into a separate hopper.

On a level with the upper part of the washing tank is an overflow tank, equal in area, and its depth 2½ feet. The object of this tank is to diminish the variation in the water level in the washing tank, consequent upon the alternate filling and emptying of the cage. A return pipe leads from the bottom of the overflow tank into the lower part of the washing tank, and this pipe is fitted with a floating check-valve, which opens down-

wards, so as to prevent the water from being driven upwards through it during the descent of the cage. The same water is used over and over again, the only loss which has to be compensated for being the small quantity which is carried off with the washed stuff; and the whole of the water is drawn off and renewed when found necessary, during the time that the apparatus is not at work.

From 120 to 150 tons of coal can without difficulty be turned out in 10 hours from the above machine by one man, the power required to work the machine being about 1-horse power.

Briefly Told.

Some weeks ago we intimated that the Washington (D. C.) Gas Light Company had purchased a large plot of ground on which it was proposed to construct an additional station, the demands of the gas consumers of the Capitol City being in excess of the capacity of the present plant. Within the last fortnight permits were issued to the Company for the erection, on the recently acquired property, of a retort house (60 x 249 ft.) to cost \$30,000, and an engine room and pumping house (63 x 100 ft.) to cost \$22,500. When these buildings are completed we understand that two gasholders will be erected.

NEVADA CITY (Cal.) has voted to adopt the Waterhouse system of electric lighting for its streets.

Correspondence

[The JOURNAL is not responsible for the opinions expressed by correspondents.]

A Simple Plan.

OFFICE OF PERU AMERICAN GAS CO., }
PERU, INDIANA, Sept. 26, 1887. }

To the Editor AMERICAN GAS LIGHT JOURNAL:

I noticed in your issue for Sept. 16 an item concerning instructions that had been given to the inspectors employed at the Philadelphia gas works. I have employed a similar system here for a year, and am well pleased with the results. I inclose you a blank of the form I use. [See below.] I place a copy of it near the meter, and as the indices are taken I enter the state and amount used each month in the proper place. I find that the consumers pay more attention to their meters, and in fact I have many now who can read them quite readily. As a consequence the "kickers" are not so numerous now as when I took charge of this plant.

There is no copyright attached to this form, and all the readers of your valuable JOURNAL are at liberty to use it if they so desire.

Yours truly,
WM. TRACY, Supt.

Copy of Form in Use at the Peru Works.

MR.
PERU AMERICAN GAS COMPANY.
INDICES METER, 188..

MONTH.	DAY.	INDEX.	AMOUNT.	REMARKS.
January
February
March
April
May
June
July
August
September
October
November
December



A. M. CALLENDER & CO.,

PROPRIETORS.

Editor—JOS. R. THOMAS, C.E.
Asst. Editor—T. J. CUNNINGHAM.
Manager—C. E. SANDERSON.

PUBLISHED ON THE 2ND AND 16TH OF EACH MONTH
At No. 42 Pine Street, New York.

This is a recognized official organ of—
LIGHT, HEAT, STEAM, WATER-SUPPLY,
VENTILATION, SANITARY IMPROVEMENT
AND GENERAL SCIENCE.

TERMS

SUBSCRIPTION—Three Dollars per annum, in advance.

AGENTS

NEW YORK—AMERICAN NEWS Co. 39 and 41 Chambers St.
BOSTON—S. M. PETTINGILL & Co., 6 State Street.
PHILADELPHIA—PRATT & Co., Corner 9th and Arch Streets.
England—C. W. HASTINGS, 22 Buckingham St., London, W C.
Germany—B. WESTERMANN & Co., of New York

MONDAY, OCTOBER 3, 1887.

The Market for Gas Securities.

The market for city gas shares still remains in a most unsettled and restricted condition, and with no valid reason for the seeming lack of confidence exhibited. During the fortnight Consolidated touched the lowest point yet recorded, and although the extreme depression did not last long, nevertheless the confidence of holders was pretty sorely tried when the tape reported sales at a figure below 69. No doubt our reiteration of the view that Consolidated shares are selling at prices much below their real value is becoming somewhat monotonous to our readers, in view of the daily market quotations, but that opinion is founded on our knowledge of the business being done by the Company and the great value of its property. Its immense real estate holdings are simply a gold mine. But although Wall street seems just now to be able to dictate values at its own sweet will, a day of reckoning is sure to come. Mutual is weaker, 20 shares having been sold within the fortnight, at 92½. Some Brooklyn shares are fairly steady, if not strong, while others are weaker. The Fulton Municipal Company has declared a quarterly dividend of 3 per cent., payable on the 15th inst. Baltimore quotations show a fairly steady market, Consolidated being quite strongly held. The Chicago situation is badly mixed, Trust certificates having been freely offered at 43. The Mercantile Trust Company, of this city, will pay the October interest coupons of bonds of the Baltimore Equitable Company. Eastern shares are strongly held. A few shares in the Springfield (Mass.) Company recently changed hands, the price paid being 158. The Boston situation is about as before, but well informed parties say that important developments may be looked for in the nearfuture. In any event, the holders of shares in the old Boston Company are not likely to part with them without having received their full value.

Gas Stocks.

Quotations by Geo. W. Close, Broker and Dealer in Gas Stocks.

16 WALL ST., NEW YORK CITY.

OCTOBER 3.

All communications will receive particular attention.
The following quotations are based on the par value of \$100 per share.

	Capital.	Par.	Bid	Asked
Consolidated.....	\$35,430,000	100	71½	—
Central.....	440,000	50	30	—
“ Scrip.....	220,000	—	47	57
Equitable.....	2,000,000	100	115	120
“ Bonds.....	1,000,000	—	113	115
Harlem, Bonds.....	170,000	—	—	—
Metropolitan, Bonds....	658,000	—	110	113
Mutual.....	3,500,000	100	91	93
“ Bonds.....	1,500,000	1000	101	—
Municipal, Bonds.....	750,000	—	—	—
Northern.....	125,000	50	39	—
“ Scrip.....	108,000	—	—	—
Yonkers.....	—	50	—	80
Richmond Co., S. I.	300,000	50	50	—
“ Bonds.....	12,000	—	—	—
Gas Co's of Brooklyn.				
Brooklyn.....	2,000,000	25	100	102
Citizens.....	1,200,000	20	50	52
“ S. F. Bonds....	320,000	1000	—	103
Fulton Municipal.....	3,000,000	100	—	127x
“ Bonds....	300,000	—	—	106
Peoples.....	1,000,000	10	60	62
“ Bonds (5's).....	368,000	—	97	—
“ “ (6's).....	94,000	—	100	—
Metropolitan.....	1,000,000	100	77	79
Nassau.....	1,000,000	25	—	100
“ Cts.....	700,000	1000	100	—
Williamsburgh.....	1,000,000	50	112	113
“ Bonds... ..	1,000,000	—	111	—
Out of Town Gas Companies.				
Boston (Mass.) Gas Co.	2,500,000	500	204	208
Buffalo Mutual, N. Y....	750,000	100	90	95
“ Bonds... ..	200,000	1000	95	100
Citizens, Newark.....	1,000,000	50	140	145
“ “ Bonds.	45,000	—	—	—
Chicago Gas Trust.....	25,000,000	100	42	44
Cincinnati G. & C. Co..	6,000,000	100	182½	185
Consolidated, Balt.....	6,000,000	100	52½	58¼
“ Bonds....	3,600,000	—	107	107½
Chesapeake, Balt.....	1,500,000	100	—	75
“	1,000,000	—	—	102
Consumers Toronto....	1,000,000	50	192	—

Advertisers Index.

GAS ENGINEERS.	Page
Jos. R. Thomas, New York City	216
Wm. Henry White, New York City.....	216
Wm. Mooney, New York City.....	216
William Gardner, Pittsburgh, Pa.....	216
GAS WORKS APPARATUS AND CONSTRUCTION.	
James R. Floyd, New York City	219
T. F. Rowland, Greenpoint, L. I.....	219
Deily & Fowler, Phila., Pa.....	219
Kerr Murray Mfg. Co., Fort Wayne, Ind.....	218
Stacey Mfg. Co., Cincinnati, Ohio.....	219
Bartlett, Hayward & Co., Baltimore, Md.....	209
Morris, Tasker & Co., Limited, Phila., Pa.....	218
Davis & Farnum Mfg. Co., Waltham, Mass.....	208
R. D. Wood & Co., Phila., Pa.....	218
Bouton Foundry Co., Chicago, Ills.....	215
Smith & Sayre Manufacturing Co., New York City.....	219
PROCESSES.	
National Gas Light and Fuel Co., Chicago, Ills.....	210
American Gas Improvement Co., Pittsburgh, Pa.....	207
GAS AND WATER PIPES.	
Gloucester Iron Works, Phila., Pa.....	216
Mellert Foundry and Machine Co., Reading, Pa. (John Fox, Selling Agent, N. Y.).....	216
Cincinnati and Newport Iron and Pipe Co., Newport, Ky.....	216
Ohio Pipe Co., Columbus, Ohio.....	215
Pancoast & Rogers, New York City.....	216
M. J. Drummond, New York City.....	216
Wells Rustless Iron Co., New York City.....	216
R. D. Wood & Co., Phila., Pa.....	218

GAS ENGINES.

Schleicher, Schumm & Co., Phila., Pa.....	192
Clerk Gas Engine Co., Phila., Pa.....	211

RETORTS AND FIRE BRICK.

J. H. Gautier & Co., Jersey City, N. J.....	214
B. Kreisler & Sons, New York City.....	214
Adam Weber, New York City.....	214
Laclede Fire Brick Works, St. Louis, Mo.....	214
Brooklyn Retort and Fire Brick Works, Brooklyn, N. Y.....	214
Borgner & O'Brien, Phila., Pa.....	214
James Gardner, Jr., Pittsburgh, Pa.....	214
Henry Maurer & Son, New York City.....	214
Chicago Retort and Fire Brick Works, Chicago, Ills.....	214
Baltimore Retort and Fire Brick Co., Baltimore.....	214
Oakhill Gas Retort and Fire Brick Co., St. Louis, Mo.....	214
Evens & Howard, St. Louis, Mo.....	215
Cincinnati Gas Retort and Fire Brick Works, Cincinnati, O.....	215
Emil Lenz, New York City.....	215

SCRUBBERS AND CONDENSERS.

G. Shepard Page, New York City.....	217
R. D. Wood & Co., Phila., Pa.....	218

REGENERATIVE FURNACES.

Bartlett, Hayward & Co., Baltimore, Md.....	209
Fred. Bredel, New York City.....	215

GAS GOVERNORS.

T. C. Hopper, Phila., Pa.....	212
Connelly & Co., New York City.....	211

CEMENTS.

C. L. Gerould, Manchester, N. H.....	214
--------------------------------------	-----

GAS ENRICHERS.

Standard Oil Co., Cleveland, Ohio.....	220
--	-----

GAS METERS.

Harris, Griffin & Co., Phila., Pa.....	222
American Meter Co., New York and Philadelphia.....	213
The Goodwin Gas Stove and Meter Co., Philadelphia, Pa.....	223
Helme & McIlhenny, Phila., Pa.....	223
D. McDonald & Co., Albany, N. Y.....	223
Nathaniel Tufts, Boston, Mass.....	222

EXHAUSTERS.

P. H. & F. M. Roots, Connersville, Ind.....	210
Smith & Sayre Manufacturing Co., New York City.....	219
Wilbraham Bros., Philadelphia, Pa.....	211
Connelly & Co., New York City.....	211

GAS COALS.

Penn Gas Coal Co., Phila., Pa.....	221
Perkins & Co., New York City.....	220
Newburgh Orrel Coal Co., Baltimore Md.....	221
Despard Coal Co., Baltimore, Md.....	221
Chesapeake and Ohio R.R. Coal Agency, N. Y. City.....	221
Westmoreland Coal Company, Phila., Pa.....	221
Monongahela & Peters Creek Gas Coal Co., Pittsburgh, Pa.....	221

CANNEL COALS.

Perkins & Co., New York City.....	220
J. & W. Wood, New York City.....	220

VALVES.

Ludlow Valve Manufacturing Co., Troy, N. Y.....	212
John McLean, New York City.....	212
Chapman Valve Manufacturing Co., Boston, Mass.....	212
R. D. Wood & Co., Phila., Pa.....	218
The Combination Gas Machine Co., Detroit, Mich.....	207

ENGINES AND BOILERS.

Jarvis Engineering Co., Boston, Mass.....	211
---	-----

PURIFYING MATERIAL.

S. H. Douglas, Ann Arbor, Mich.....	215
Connelly & Co., New York City.....	211

GAS LAMPS.

The Siemens-Lungren Co., Philadelphia, Pa.....	217
G. Shepard Page, New York City.....	212
Alho-Carbon Light Co., Newark, N. J.....	207
Standard Gas Lamp Co., Phila., Pa.....	215

PURIFIER SCREENS.

John Cahot, New York City.....	183
Geo. A. Mills, Baltimore, Md.....	212

GAS STOVES.

American Meter Co., New York and Philadelphia.....	223
The Goodwin Gas Stove and Meter Co., Phila. Pa.....	224
The Combination Gas Machine Co., Detroit, Mich.....	207
Dinsmore Manufacturing Co., Boston, Mass.....	207

STREET LAMPS.

J. G. Miner, Morrisania, New York City.....	175
Bartlett Street Lamp Mfg Co., New York City.....	215

BURNERS.

C. A. Gefroter, Phila., Pa.....	220
---------------------------------	-----

STEAM BLOWER FOR BURNING BREASE.
H. E. Parson, New York City..... 184

GASHOLDER TANKS.
W. C. Whyte, New York City..... 218

GAS FIXTURES.
Mitchell, Vance & Co., New York City..... 212

COKE CRUSHER.
C. M. Keller, Columbus, Ind.... 221

GAS BAGS.
Peerless Manuf'g Co., New York City..... 211

ELECTRICAL APPARATUS.
Waterhouse Electric & Manufg Co., Hartford, Conn..... 208

BOOKS, ETC.
English Journal of Gas Lighting..... 207
Gas as a Source of Light, Heat and Power..... 212
Goodwin's Directory of Gas Light Companies..... 220
King's Treatise..... 222
Scientific Books..... 222
Management of Small Gas Works..... 216
Newbigging's Gas Manager's Handbook..... 222
Gas vs. Electricity..... 219
Practical Electric Lighting..... 207
Electric Light Primer..... 207

Position Wanted.

A Gas Engineer and Mechanical Draughtsman, thoroughly experienced in construction and erection of machinery for coal, oil, and water gas, is open for suitable employment. First-class references. Address "A. M., 15," care this Journal.



FOR HEATING rooms of any size. Warranted odorless, or the purchase money refunded. DINSMORE MANUFACTURING CO., 28 Kneeland Street, Boston, Mass. Send for Catalogue.

ENGLISH
"Journal of Gas Lighting."

Issued weekly. New volume commences Jan. 1, 1887. Price, \$7 per annum. Subscriptions taken by
CHARLES NETTLETON, Agent for U. S.,
No. 115 BROADWAY, N. Y. CITY.

Practical Electric Lighting,

By A. BROMLEY HOLMES, A.M.I.C.E.
With 87 Illustrations. Third Edition. Price, \$1.00.

Electric Light Primer.

By CHARLES L. LEVEY.
A simple and comprehensive Digest of all the most important facts connected with the running of the Dynamo and Electric Lights, with Precautions for Safety, etc.
Price, 50 cents.

A. M. CALLENDER & CO., 42 Pine St., N. Y.

ENGAGEMENT DESIRED

As Superintendent of Small Gas Works or Assistant in a Large Works.

Best of references given. Address 679-1 "C. J.," care this Journal.

Situation Wanted.

A practical young man of several years' experience as Superintendent of Small Gas Works desires to make a change. Best of references. Address "M.," Care this Journal.

GAS STOVES

Of Every Description, for Heating, Cooking, Laboratory, and Mechanical Purposes.

Weber Straight-Way Valves

FOR GAS, STEAM, AND WATER. Catalogues on Application. Correspondence Solicited.

THE COMBINATION GAS MACHINE CO.,
Detroit, Mich. Windsor, Ont.

163 Maiden Lane, N. Y. City. 87 Dearborn Street, Chicago, Ill.

Illuminating Gas from Natural Gas.

THE AMERICAN GAS IMPROVEMENT CO., Limited, 95 Fifth Avenue, Pittsburgh, Pa.

Erect Apparatus for the treatment of Natural Gas for an Illuminant under the

McKAY-CRITCHLOW SYSTEM.

Satisfaction in Economy and Quality Guaranteed.

Apparatus adapted to the manufacture of Water Gas, without any change whatever, should it be desirable to do so on account of Natural Gas playing out. Apparatus erected or Licenses sold at the following Works.

Pittsburgh Gas Works, J. H. McElroy, Engr.
Allegheny Gas Works, Robt. Young, Engr.
East End Gas Works, W. H. Denniston, Engr.
West Pittsburgh Gas Works, E. C. Critchlow, Supt.
Beaver Falls Gas Works, H. F. Dillon, Supt.
Titusville Gas Works, E. T. Roberts, Treas.
Salamanca, N. Y.
Jamestown, N. Y.
Meadville, Pa., Wm. Reynolds, Prest.

Warren, Pa., S. S. Franklin, Supt.
Franklin, Pa., C. W. Gilfillan, Prest.
Oil City, Pa.
Erie Gas Co., Erie, Pa., W. H. Hill, Engr.
Greensburg, Pa., Jas. C. Clarke, Prest.
Sewickley, Pa., J. W. Forbes, Supt.
Bellaire, Ohio, John Ferguson, Supt.
New Castle, Pa., D. T. Flick, Supt.
Corry, Pa.

Sharon, Pa., S. Perkins, Prest.
Fort Scott, Kansas, L. K. Scofield, Owner.
Fostoria, Ohio, Jos. Gwynn, Supt.
Emporia, Kansas.
Tiffin, Ohio.
Wellsville, Ohio.
Brownsville, Pa.

THE ALBO-CARBON LIGHT.

THIS SYSTEM HAS SHOWN ITSELF IN THOUSANDS OF CASES—IN HALLS, CHURCHES, PICTURE GALLERIES, CONCERT HALLS, RESTAURANTS, BANKS, CLUBS, STORES, OFFICES, and PRIVATE RESIDENCES—TO BE THE

Best Adapted and Most Successful Method of Gas Lighting Ever Offered.

The SOFTNESS AND PURITY OF THE LIGHT make it most desirable for Office and Household Uses. Its BRILLIANCY and POWER render it unrivaled for lighting Halls, Churches, etc. Its ECONOMY secures for it general favor wherever used.

NOTICE.—Suits are pending in the United States Circuit Courts in Illinois and Pennsylvania against various parties for infringement of our Letters Patent No. 247,925, dated October 4, 1881, and No. 333,862, dated January 5, 1886. The first of these suits has come up for hearing, and an injunction has been granted therein. The second of said suits has not yet been reached for hearing. All persons are cautioned against manufacturing, selling, or using any apparatus or material which infringes our patents. We intend to prosecute all parties infringing patents owned by us.

ALBO-CARBON LIGHT CO. (Sole Manufacturers for the United States) Main Office, Newark, N. J.



The Waterhouse System of Arc & Incandescent Lighting

Is invariably appreciated by electricians. The light produced is remarkably steady, and the regulation wonderful. The efficiency of the dynamos (closed circuit) is a large percentage in our favor as compared with that of the open circuit machines, so that we show **GREAT ECONOMY.**

Investigation Invited by Electrical Experts and Others.

SEND FOR CATALOGUE.

THE WATERHOUSE ELECTRIC AND MFG. COMPANY,
Factory, Colt's West Armory. **Hartford, Conn.**

To All Whom It May Concern!

The SIEMENS-LUNGRÉN COMPANY hereby warns the public against the use of various infringing Regenerative Gas Lamps which are offered for sale. This Company has heretofore delayed bringing suit to enjoin the manufacture or importation of such infringing lamps, solely because of the practical worthlessness of the infringing devices; and although, in each instance, they infringe some one or more of the various patents owned or controlled by this Company, they have fallen into disuse sooner than any suit could be brought to a hearing. As, however, the introduction of these infringing lamps has tended to discredit the practicability of our Company's system of regenerative gas lighting, we have instructed our Attorneys, Messrs. Geo. Harding, C. S. Whitman, and Silas W. Pettit, to give notice that legal proceedings will in future be taken against all such infringers.

THE SIEMENS-LUNGRÉN CO., 21st St. & Washington Av., Phila., Pa.

F. J. DAVIS & J. R. FARNUM,

TRUSTEES AND AGENTS FOR THE

SINUOUS FRICTION CONDENSER.

We desire to draw the attention of the gas community to the merits of the **SINUOUS FRICTION CONDENSER.** Companies intending to introduce new condensers into their works will do well to confer with us and examine plans and estimates before contracting for any other pattern. The **FRICTION CONDENSER** is now in use at the gas works located in the following places:

Portland, Me.	Brookline, Mass.	Pawtucket, R. I.	Frederickton, N. B.
Newport, R. I.	Chelsea, Mass.	Jamaica Plain, Mass.	St. John, N. B.
Gloucester, Mass.	Woburn, Mass.	Attleboro, Mass.	Paterson, N. J.
Newton & Water- town, Mass.	Peoria, Ill.	Calais, Me.	Dover, N. H.
	Clinton, Mass.	Fall River, Mass.	Waltham, Mass.
		Nassau Works, Brooklyn, N. Y.	

DAVIS & FARNUM MFG. CO.

MANUFACTURERS OF

Gas and Water Pipes,

AND

GAS AND WATER MACHINERY

OF THE MOST APPROVED PATTERN.

Also, Gasholders and Iron Roofing.

Orders from Gas and Water Companies promptly attended to.

WALTHAM, MASS.

Boston Office, Room 55, Mason Building, 70 Kilby Street.

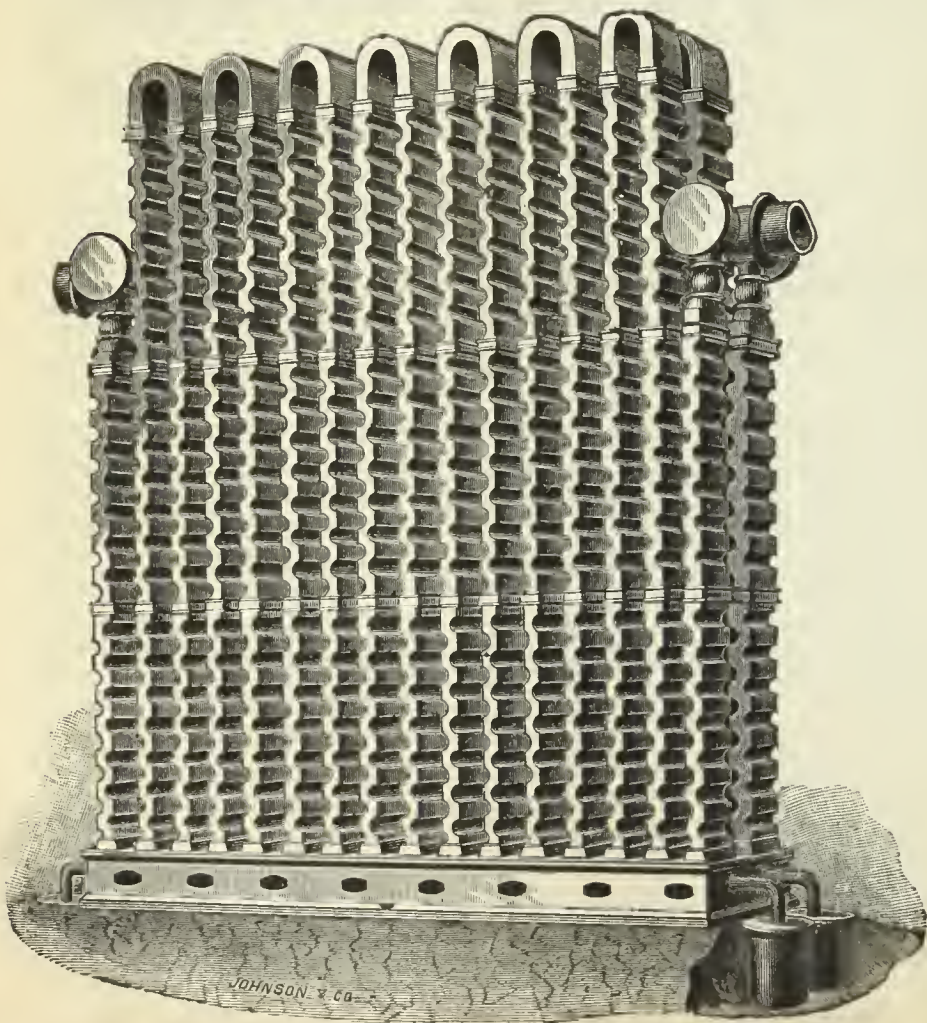

BARTLETT, HAYWARD & CO.

Baltimore, Md.

Munich Regenerative Furnace, System Drs. Schilling & Bunte.

Greatest durability; minimum of attention; complete distillation in 3½ hours; 10 to 13 pounds of coke to hundred-weight of coal; no clinker; no carbonic oxide in regenerative flues.

TWO AND THREE-LIFT TELESCOPIC GASHOLDERS,

With Wrought Iron Tanks, constructed above ground, of any magnitude.

Condensers, Scrubbers, Purifiers, Bench Castings, Roofs, Boilers, Etc.

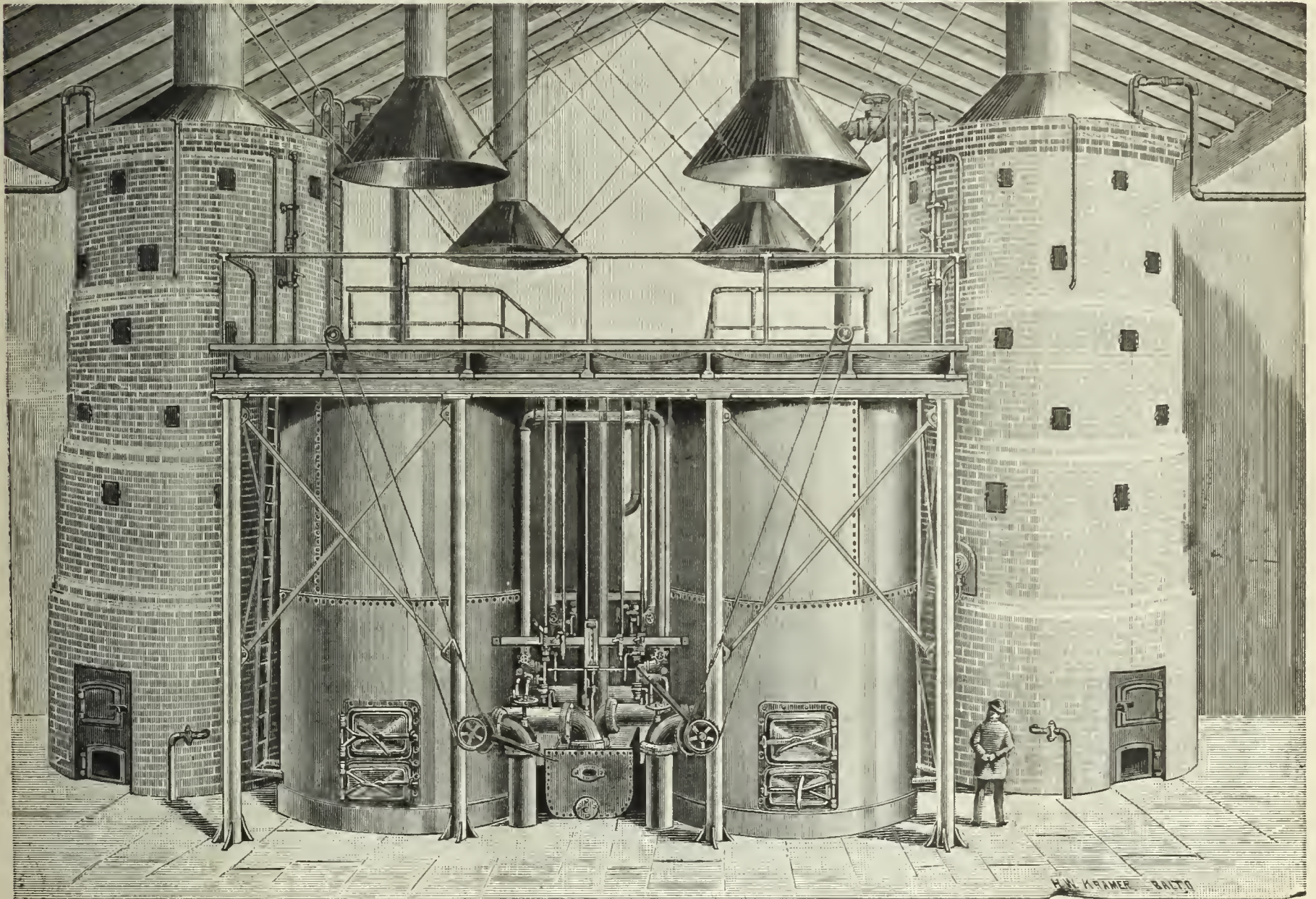

The Wilkinson Water Gas Process.

Introducing the Munich Regenerative Furnace for Coal Gas, we find on the part of many Gas Companies the desire to combine to a greater or less extent an efficient system of making high candle power Water Gas; and with a view of enabling this to be done WITHOUT EXCESSIVE CHARGES FOR PATENT RIGHTS, ETC., we have acquired, by purchase, the exclusive right to construct all the Water Gas Apparatus under the valuable "Wilkinson" Patents.

The results obtained by this Process are far better than those obtained by any other apparatus, especially where an illuminating gas of high candle power or a fuel gas of intense temperature is required.

The Process is uninterrupted, making gas of uniform quality and quantity. Its greatest advantages are maximum production with minimum material and labor, combined with great durability of apparatus.

The Process is in successful operation at the works of the N. Y. Mutual Gas Company, New York; Consolidated Gas Company, Baltimore, Md.; the Hudson County Gas Light Company, of Hoboken, N. J.; and at Rye, N. Y.

We shall be glad to give further detailed information upon application.

Sole Agents for the Celebrated Hazelton Boiler.

BARTLETT, HAYWARD & CO.

EXHAUSTERS.

EXHAUSTERS.

PROCESSES.

ROOTS' NEW GAS EXHAUSTER.

St. Louis, Mo., }
March 21, 1887. }

Messrs. P. H. & F. M. Roots, Connorsville, Ind.:
Dear Sirs—In 1872 one of your No. 5 Exhausters was placed in these works, and worked satisfactorily. In March, 1885, it was replaced by one of your No. 6 Exhausters. The latter has been in almost constant use the past two years, has worked up to all my expectations, and is to-day in apparently as good condition as when first set up. It has not cost one cent for repairs in all that time. I have also

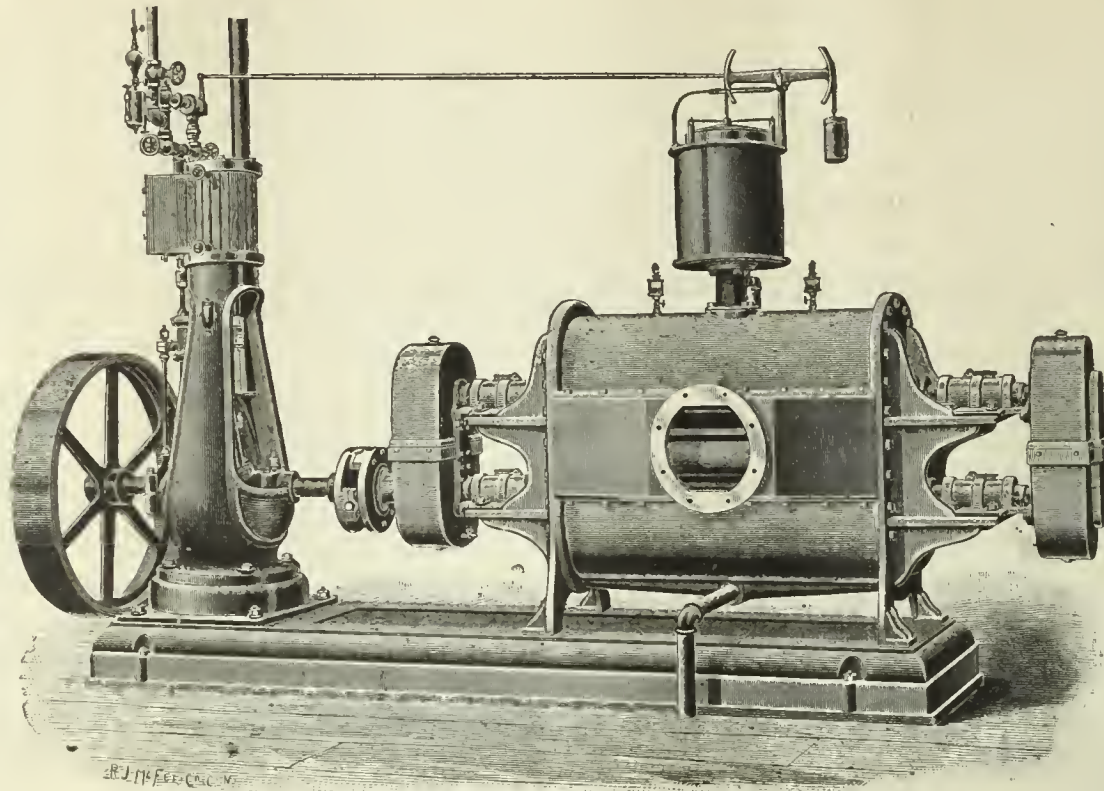

had one of your No. 1 Exhausters, with Engine on same bed-plate, fitted with your valves and Hnntoon Governor, placed in a small works under my control, and in its operation it seems as near perfection as I ever expect an Exhauster to become. Without in the least disparaging Exhausters of other makes, I may say that your Exhanster may be safely recommended as unsurpassed by any other, to those requiring such machines.

Yours respectfully,
FREDERIC EGNER,
Eng. and Supt.

CONSTRUCTED ON ENTIRELY NEW PRINCIPLES.

THE ONLY EXHAUSTER MADE IN WHICH

The Internal Operating Parts Consist of Only Two Pieces, Each Cast Entire in One Piece.

Send for Descriptive Catalogue and Price List.

P. H. & F. M. ROOTS, Patentees and Manufacturers, **CONNERSVILLE, IND.**

S. S. TOWNSEND, Gen. Agt., 22 Cortlandt St., N. Y. COOKE & CO., Selling Agts., 22 Cortlandt St., N. Y.

NATIONAL GAS LIGHT AND FUEL COMPANY,

No. 218 La Salle Street, Chicago.

THE SPRINGER SYSTEM

OF

Fuel and Illuminating Water Gas Works.

REFERENCES.

People's Gas Light and Coke Co.....	Chicago, Ill.	Mankato Gas Light Co.....	Mankato, Minn.
Elgin National Watch Co.....	Elgin, Ill.	Minneapolis Gas Light and Coke Co.....	Minneapolis, Minn.
C. R. I. & P. R. R. Shops.....	Chicago, Ill.	Lima Gas Light Co.....	Lima, Ohio.
Decatur Gas Light and Coke Co.....	Decatur, Ill.	Bellevue Water and Fuel Gas Light Co.....	} Bellevue, Campbell County, Ky.
Niles Gas Light Co.....	Niles, Mich.	Bucyrus Gas Light and Fuel Co.....	
Newton Illuminating Co.....	Newton, Kansas.	Morris Gas Co.....	Morris, Ill.
Wellington Light and Heat Co.....	Wellington, Kansas.	Los Angeles Gas Co.....	Los Angeles, Cal.
Chippewa Falls Gas Light Co.....	Chippewa Falls, Wis.	San Diego Gas Fuel and Electric Lt. Co.....	San Diego, Cal.
Elkhart Gas Light and Coke Co.....	Elkhart, Ind.	Jackson National Gas Co.....	Jackson, Mich.
Madison City Gas Light Co.....	Madison, Wis.	Sioux Falls Gas Co.....	Sioux Falls, Dak.
South Bend Gas Light Co.....	South Bend, Ind.	Dakota Gas and Fuel Co.....	Grand Forks, Dak.
Sheboygan National Gas Co.....	Sheboygan, Wis.	St. Johns Mutual Gas Co.....	St. Johns, Mich.
Salina Gas Light Co.....	Salina, Kansas.	Stillwater Gas Light Co.....	Stillwater, Minn.
The Rathbnn Co.....	Deseronto, Prov. Ont.	St. Paul Gas Light Co.....	St. Paul, Minn.
Jefferson City Gas Light Co.....	Jefferson City, Mo.		

GUARANTEED ESTIMATES of Cost of Gas Furnished on Application.

CONNELLY & CO., LTD.,

SOLE MANUFACTURERS OF THEIR PATENTED SPECIALTIES.

"IRON SPONGE." Saves money, saves labor, and is the most efficient purifying agent ever offered as a substitute for lime. Now used *in every State in the Union*, and purifying daily over *twenty-five million cubic feet*. Should be used in every gas works. Its own saving will pay for it many times over.

AUTOMATIC GOVERNOR. Has been on the market but *two years*, and in that time has been introduced *more generally* than any invention ever designed for use in gas works. Over *one hundred* of them now in use. Sensitive; reliable; perfectly automatic; reduces leakage; satisfies consumers, and gives great relief to the Manager. No gas works is *complete* without one of these machines.

STEAM JET EXHAUSTER. Designed particularly for small works. Combines Exhaust Tube, Steam Governor, Gas Compensator, and Bye-Pass Valves in the most compact form possible; occupies but little space; uses very little steam; operated by ordinary workmen; saves formation of carbon in retorts; increases yield 10 to 15 per cent. Specially adapted for *mixing air* with oil gas. *No works* too small to use them profitably.

Prices given on all our specialties *delivered at any point in the United States*. Correspondence solicited.

CONNELLY & CO., LTD., No. 177 Broadway, New York City.

WILBRAHAM GAS EXHAUSTER AND ENGINE COMBINED.

WILBRAHAM BROS., PHILADELPHIA, PA.

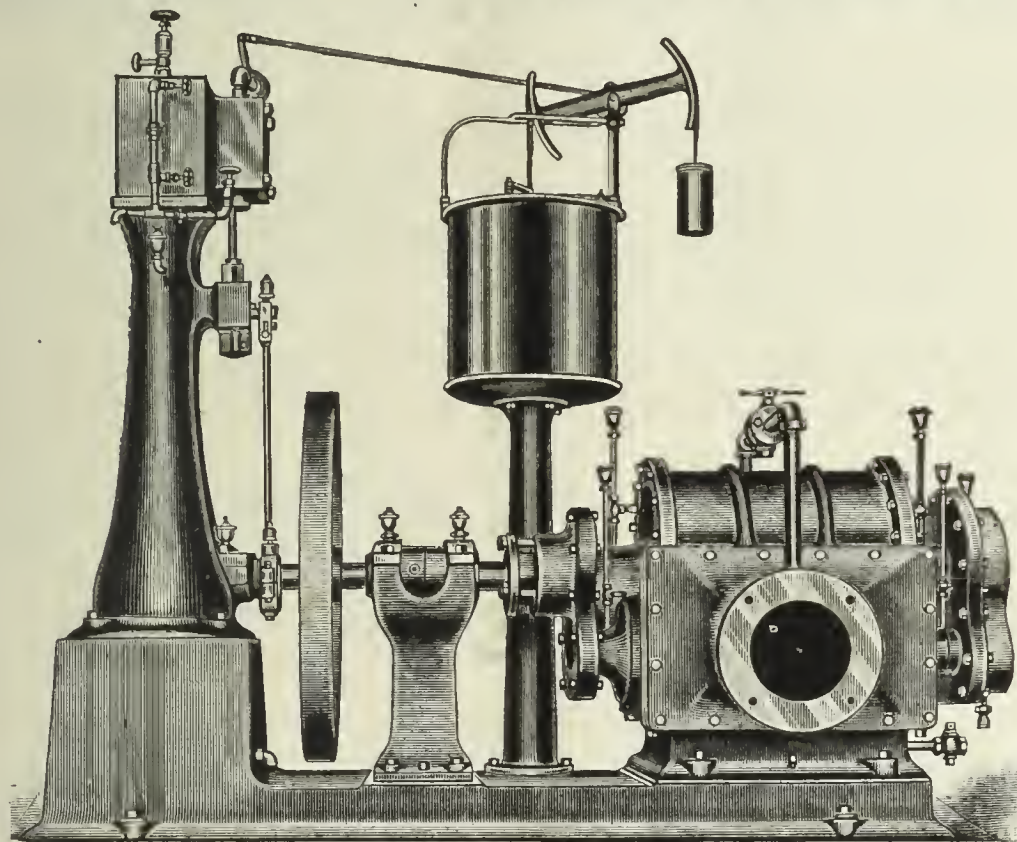

JARVIS ENGINEERING CO.,

61 Oliver St., Boston, Mass.

CONTRACTORS FOR ERECTING

COMPLETE STEAM OUTFITS FOR ELECTRIC LIGHTING STATIONS.

Steel Boilers set with Jarvis Pat. Boiler Setting

To burn **COKE SCREENINGS** for Fuel.

ARMINGTON & SIMS CO. ENGINES,

Belting direct to Dynamos, without using Shafting.

SEND FOR CIRCULARS.

REFERENCES:—Charlestown Gas & Electric Light Co., Charlestown, Mass.; Schenectady Gas & Electric Light Co., Schenectady N. Y.; Brookline Gas Co., Brookline, Mass.

Improved Patent GAS BAG OR BLADDER VALVE.

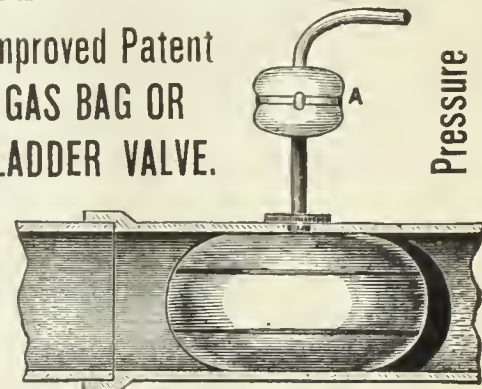

Pressure Indicator.

MANUFACTURED BY PEERLESS MFG. CO., 34 Murray St., N.Y.

THE CLERK GAS ENGINE CO.,

Main Office, 1012, 1014, 1016, 1018 Filbert St., Philadelphia, Pa.

WM. W. GOODWIN, Prest.

E. STEIN, Sec.

S. LEWIS JONES, Asst. Sec.

A. J. DOTY, Supt.

The utility and convenience of the Gas Engine being no longer an open question, it only remains now for intending purchasers to select the BEST. We claim for the CLERK GAS ENGINE that it is equal to any other manufactured as regards steadiness in running, simplicity, and ease of keeping in repair, and that it gives the greatest amount of power for the least money (both in first cost and expense of running) of any engine made. In support of this claim we refer to the test of the Gas Engines made under the direction of the American Institute of New York, in December, 1885, and heretofore published in these columns. These engines are especially adapted for continuous running under heavy loads, and we can refer to Engines which have run 22 hours a day for months at a time.

Made in Sizes of 5, 10, 15, 20, and 25 Horse Power. All Engines Guaranteed for One Year.

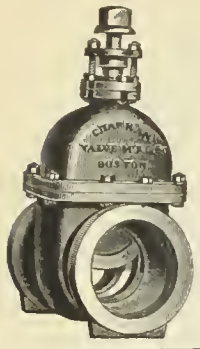

CHAPMAN VALVE MANUFACTURING CO.,

MANUFACTURERS OF

Valves and Gates for Gas, Ammonia, Water, Etc.

Also, Gate Fire Hydrants With and Without Independent Nozzle Valve. All Work Guaranteed.

WORKS & GEN'L OFFICE:
Indian Orchard, Mass.

TREASURER'S OFFICE:
72 Kilby & 112 Milk Sts, Boston, Mass.

LUDLOW VALVE MFG. CO.

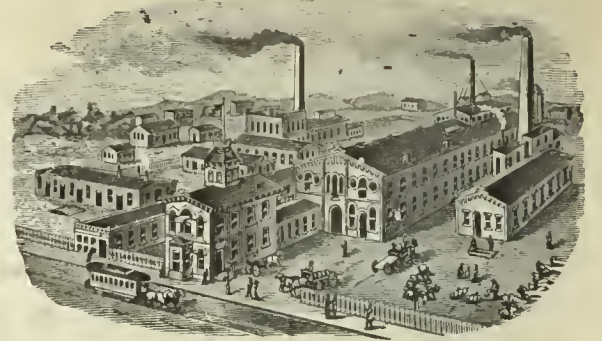

OFFICE AND WORKS,
938 to 954 River Street and 67 to 83 Vail Av
TROY, N. Y.

Hydraulic Main Dip Regulators, also
Check Valves, Foot Valves, Yard-
wash and Fire Hydrants.
Send for Circulars.

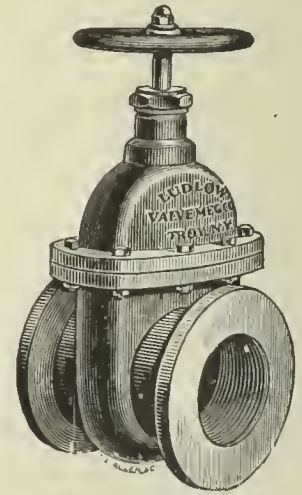

Valves.—Double and Single Gate, ½ in. to
48 in., outside and inside Screws. Indica-
tor, etc., for Gas, Water, Steam, and Oil.
Send for Circulars.

How to Reduce Leakage to Its Minimum.

USE

HOPPER'S AUTOMATIC DIFFERENTIAL GAS GOVERNOR.

Needs No Attention. Simple, Reliable, Perfectly Automatic.
"Nearly Thirty in Use."

BYE-PASSES, DRY CENTER VALVES, PRESSURE REGISTERS. Also, GOVERNORS FOR
STREET MAINS, *NOT DIFFERENTIAL*, and for EXHAUSTERS, GAS ENGINES, etc.
Our new Bye-Pass is threefold in its action—passes gas through, or bye-passes, or shuts off entirely.
Correspondence solicited; information given. Send for circulars and testimonials.

T. C. HOPPER & CO., - - No. 227 Wood Street, Philadelphia, Pa.

MILLS' REVERSIBLE LIME TRAY,

AND

WOODWORK

Of Every Description

NEEDED BY GAS WORKS.

SEND FOR CIRCULAR AND PRICE LIST TO

GEORGE A. MILLS,

Canton Av. & President St., Baltimore, Md.

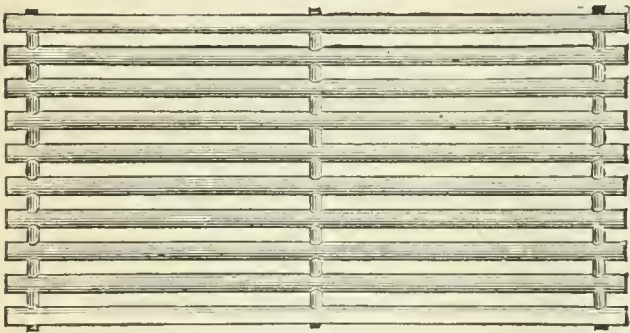

GEO. SHEPARD PAGE,

No. 69 Wall Street, N. Y. City.

REPRESENTING

THE BOWER GAS LAMP.

C. & W. Walker's Carbonic Acid & Tar Extracting Washer

B. DONKIN & CO.'S PAT. IMP. GAS VALVE.

Young & Beilby's Patents. Henry Aitkin's Patents.

R. P. SPICE, London, Eng. HENRY SIMON, Manchester, Eng.

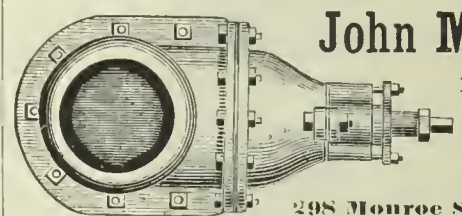

John McLean

Man'facturer of

**GAS
VALVES.**

298 Monroe Street, N. Y.

MITCHELL VANCE & CO.,

MANUFACTURERS OF

Chandeliers

and every description of

GAS FIXTURES.

Also manufacturers of Fine Gilt Bronzes and Marble Clocks,
warranted best time-keepers. Mantel Ornaments, etc.

Salesrooms, 836 Broadway, N. Y.

Special Designs furnished for Gas Fixtures for Churches, Public
Halls, Lodges, etc.

GAS AS A SOURCE OF LIGHT, HEAT, AND POWER.

By C. J. R. HUMPHREYS

A Pamphlet of twenty-nine pages, treating of the use of Gas as a
source of Light, Heat, and Power.

DESIGNED FOR DISTRIBUTION BY GAS COMPANIES AMONG THEIR CUSTOMERS AND OTHERS.

Price, 10 cents each, \$5 per 100, \$50 per 1,000.

Gas Companies can have their own imprint placed on cover without extra charge. All orders to be sent to

A. M. CALLENDER & CO.,

No. 42 Pine Street, N. Y. City.

GAS METERS.

GAS METERS.

GAS METERS.

THE AMERICAN METER CO.,

MANUFACTURERS OF

WET AND DRY GAS METERS.

Extreme Simplicity in construction! More Freedom in action! Less Friction when at work! Greater Facility for Cleaning! Perfect Accuracy in Registration!

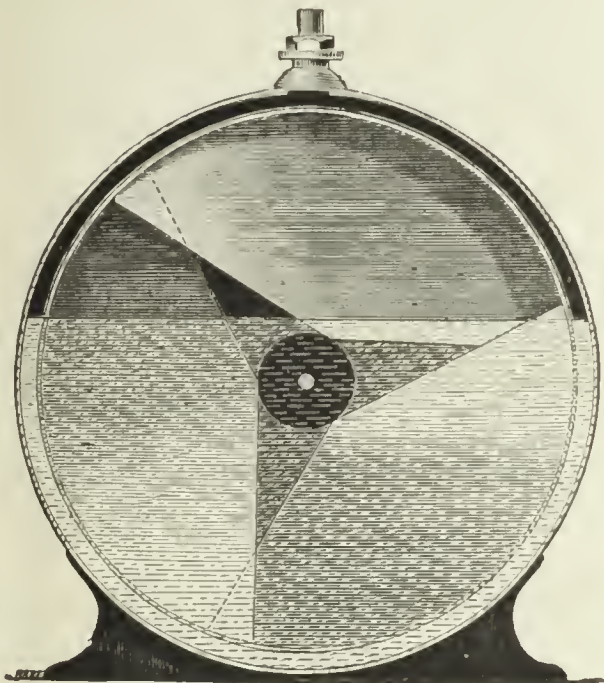

Patented May 27, 1884.

Nearly 5,000 Meters fitted with these Three-Partition Drums are in use, including Consumers' Meters, Official Standard Test Meters, and Station Meters in all sizes.

Sole Licensees in the United States for

PARKINSON'S THREE-PARTITION DRUM

For Consumers' and Station Meters.

August 22d, 1887.

Having thoroughly examined this improvement in Meter Drums, we confidently recommend their use in *Station Meters* and *Wet Meters* of smaller sizes. Among the many advantages that can be claimed for this Drum is its Increased Capacity—amounting to nearly 25 per cent. We are prepared to give estimates for new station meters or rebuilding old station meters upon this system. AMERICAN METER COMPANY.

MANUFACTORIES,

508 to 514 West Twenty-second St., N. Y.

Arch and Twenty-second St., Phila.

Nos. 244 & 246 North Wells Street, Chicago, Ill.

AGENCIES,

No. 177 Elm Street, Cincinnati, Ohio.

No. 222 Sutter Street, San Francisco Cal.

No. 810 North Second Street, St. Louis, Mo.

GAS STOVE SHOW ROOMS, No. 223 Sixth Avenue, New York City.

RETORTS AND FIRE BRICK.

J. H. GAUTIER & CO..

CORNER OF

GREENE AND ESSEX STREETS.

JERSEY CITY, N. J.

MANUFACTURERS OF

Clay Gas Retorts,**Gas House Tiles,****Fire Bricks, Etc. Etc.**Ground Clay, Fire Brick and
Fire Sand in Barrels,J. H. GAUTIER.
C. E. GREGORY.T. B. GAUTIER.
C. E. GAUTIER.**BROOKLYN****Clay Retort & Fire Brick Works,**

(EDWARD D. WHITE & CO.)

Manufacturers of Clay Retorts, Fire Brick,
Gas House and other Tile.

VAN DYKE, ELIZABETH, RICHARDS & PARTITION STS.

Office, 88 Van Dyke St., Brooklyn, N. Y.

RETORTS AND FIRE BRICK.

LAGLEDE FIRE BRICK MFG. CO.,

MANUFACTURERS OF

Fire Brick, Gas Retorts,

AND

ST. LOUIS STANDARD SEWER PIPE.Blast Furnace and Cupola Linings, every description of Fire
Clay Material, Fire Clay Flue Linings, Chimney Tops
Dry Milled and Crude Fire Clays, etc.

OFFICE AND DEPOT

901, 903, and 905 Pine Street,

ST. LOUIS, MO.

ESTABLISHED IN 1845.

B. KREISCHER & SONS,

OFFICE FOOT OF HOUSTON ST., E. R., N. Y.

Gas Retorts,**TILES, FIRE BRICK.**

AND EVERYTHING IN THE FIRE CLAY LINE.

RETORTS AND FIRE BRICK.

MANHATTAN

FIRE BRICK & ENAMELLED CLAY

RETORT WORKS.**ADAM WEBER.****CLAY GAS RETORTS**

AND RETORT SETTINGS

FIRE BRICKS, TILES, ETC.,

Office and Works, 15th Street and Avenue C., N. Y.



Works,

LOCKPORT STATION, PA.

—ESTABLISHED 1864.—

JAMES GARDNER, JR.,

Successor to WILLIAM GARDNER & SON.

Office, Rooms 19 & 20, Lewis Block,

PITTSBURGH, PA., P. O. Box 373.

Fire Clay Goods for Gas Works.

CHAS. H. SPRAGUE & SON, No. 70 KILBY STREET, BOSTON, MASS., Agents for the New England States.

OFFICE, 418 to 422 East 23d St., New York.

ESTABLISHED 1856.

WORKS, PERTH AMBOY, NEW JERSEY.

HENRY MAURER & SON,**Excelsior Fire Brick & Clay Retort Works**

CLAY GAS RETORTS, BENCH SETTINGS, FIRE BRICK, TILES, ETC.

CHICAGO**Retort & Fire Brick Works,**

OFFICE AND FACTORY,

Clark, Forty-Fifth, and La Salle Streets,

CHICAGO, ILL.

GEORGE C. HICKS, PRES. PAUL P. AUSTIN, SEC. & TREAS.

STANDARD

Clay Retorts and Settings.**BLOCKS & TILES**

Of every Shape and Size to Order.

Standard Fire Bricks.**GEROULD'S IMPROVED RETORT CEMENT.**A Cement for patching retorts, putting on mouthpieces, and
making up all bench-work joints. This Cement is mixed ready
or use. Economic and thorough in its work. Fully warranted
stick. For recommendations and price list address**C. L. GEROULD,**

Manchester, N. H.

Western Agent, H. T. GEROULD, Mendota, Ill.

OAKHILL**GAS RETORT & FIRE BRICK**

Works.

Proprietors,

PARKER-RUSSELL MINING & MFG. CO.

City Office, 711 Pine Street,

ST. LOUIS, MO.

Our immense establishment is now employed almost entirely in
the manufacture of**MATERIALS FOR GAS COMPANIES.**We have studied and perfected three important points. Our re-
torts are made to stand changes of temperature, the strongest
heats of the furnace, and the abrasion of feeding and emptying.
Our customers are in almost every State of the Union, to all of
whom we refer

THOS. SMITH, Prest.

AUGUST LAMBLA, Vice-Prest. & Sup

BALTIMORE**RETORT & FIRE BRICK CO.**

MANUFACTORY AT

LOCUST POINT, BALTIMORE, MD.

Connection with the City by Telephone.

Clay Retorts, Blocks & Tiles,**FIRE BRICK, FIRE CLAY,****AND FIRE CEMENT.**Red and Buff Ornamental Tiles and Chim-
ney Tops. Drain and Sewer Pipe (from
2 to 30 inches). Baker Oven Tiles
12 x 12 x 2 and 10 x 10 x 2.

WALDO BROS., 88 WATER ST., BOSTON, MASS

Sole Agents the New England States.

EVENS & HOWARD,

916 Market St., St. Louis. Mo.

Works, Howard Station, Mo. Pacific R.R.

Fire Brick, Gas Retorts

AND

RETORT SETTINGS.

Sewer Pipe, 3 to 24 in. diameter.

Glass Pot Clay, Ground Fire Clay, in barrels and in bulk. All kinds of Fire Clay Goods.

Cincinnati Gas Retort & Fire Brick Works.

—ESTABLISHED 1872.—

CHAS. TAYLOR,

MANUFACTURER OF

Gas Retorts, Fire Brick, and Tile.

Blast Furnace Linings, Cupola Blocks, Boiler Tiles, Grate Settings, and Stove Linings. Fire Cement, Fire Clay, Fire Sand, and all other Fire Clay Goods.

Branch Works, New Cumberland, W. Va.

GENERAL OFFICE AND WORKS,

Burns St., Cincinnati, Ohio.

EMIL LENZ,

2 & 4 Stone St., N. Y. City.

CLAY GAS RETORTS

(ENAMELED.)

Fire Brick, Blocks & Tiles.

FIRE CEMENT, RETORT ENAMEL, RETORT CEMENT, ETC., ETC.

Regenerative and Half-Regenerative Benches.

PORTLAND CEMENT.

Correspondence Respectfully Solicited.

Bouton Foundry Co.,

FOUNDERS AND MACHINISTS,

CHICAGO, ILL.

Gas Works Apparatus,

PURIFIERS, CONDENSERS,

Bench Work,

SPECIALS, LAMP POSTS,

SCRUBBERS,

Iron Roofs and Floors.

Plans and Estimates furnished for new works or extensions of old works.

PATENTS.

FRANKLIN H. HOUGH,

Solicitor of American & Foreign Patents

925 F. ST., WASHINGTON, D. C.

(NEAR U. S. PATENT OFFICE.)

Personal attention given to the preparation and prosecution of applications for Letters Patent. All business before the U. S. Patent Office attended to for moderate fees. No Agency in the United States possesses superior facilities for obtaining Patents, or for ascertaining the patentability of inventions. Copies of patents furnished for 25 cents each. Correspondence solicited.

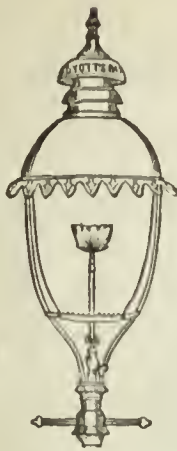

STEPHEN A. MORSE, President.
GODFREY REBMANN, Vice-Pres.

M. B. DYOTT,
Superintendent.

EDWIN F. MORSE, Secretary.
CARLTON M. WILLIAMS, Treas.

STANDARD GAS LAMP CO.,

Office, 411 Cherry St. Factory, 1101, 1103 & 1105 Frankford Av.

Philadelphia, Pa.

It is to the interest of Gas Companies and Cities to use Dyott's Patent Champion Lamps, which give double the light with the same consumption of gas, and will save 50 per cent. over others in cost of keeping in repair. Gas Companies and others intending to erect Lamps of any description will do well to communicate with us. Special Drawings furnished and Estimates given on application upon Architects', Engineers' or our Draughtsmen's Plans.

Our Patent System of Instantaneously Lighting Gas (without electricity) for R. R. Depots is unequalled. Our High Candle Power Burner is superior to the Electric Light or any other High Candle Burner. We manufacture every description of Ornamental Lamps.

KLOENNE & BREDEL

IMPROVED REGENERATIVE FURNACES.

Self-Sealing Mouthpieces & Bridge-Pipes, Retort Houses,

WASHER-SCRUBBERS

Gasholders, and Complete Gas Works.

Refers, by permission, to Mr. Eugene Vanderpool, of Newark, N. J.; Mr. E. G. Cowdery, of Milwaukee, Wis.; and Mr. Theo. Forstall, of Chicago, Ill. For further information apply to

FRED. BREDEL, 332 East 17th St., N. Y. City.

G. S. COOK, Pres.

THOS. DAVENPORT (late Davenport Bros.), Sec. & Treas

BARTLETT

Street Lamp Mfg. Co.

MANUFACTURERS OF

Bartlett's Patent

GLOBE LAMPS,

FOR

Streets, Parks, Railroad Stations, Public Buildings, Etc.

LAMP POSTS A SPECIALTY.

Office and Salesroom

40 & 42 College Place, N. Y. City.

Gas Companies and others intending to erect lamps and posts will do well to communicate with us.

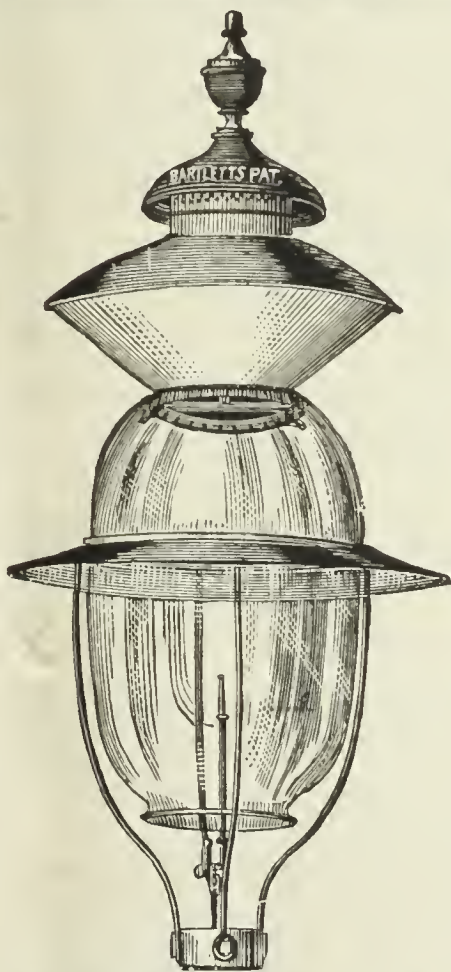

Ferric Oxide for Gas Purification.

Ferric Oxide, as ground, screened, and prepared by me for purifying purposes, has now been in use for several years by many of the gas works throughout the country, including Detroit, Chicago, Milwaukee, East Saginaw, Burlington (Iowa), Ann Arbor, etc. It has proved, as I believe, the Most Effective and Economical Agent now in use. I am prepared to furnish the Oxide by the 100 lbs. or in car load lots, and will be pleased to give price f.o.b. cars at Ann Arbor or at place of destination. Address

S. H. DOUGLAS, Prest. Ann Arbor (Mich.) Gas Light Co.

GAS AND WATER PIPES.

GAS AND WATER PIPES.

ENGINEERS.

SAM'L R. SHIPLEY, Pres.
HENRY B. CHEW, Treas.

JAS. P. MICHELLON, Sec.
WM. SEXTON, Supt.

P. D. WANNER, Chairman. A. H. MELLERT, Sec. & Treas.

GLOUCESTER IRON WORKS.
GLOUCESTER CITY, N. J.



Cast Iron Gas & Water Pipes, Stop Valves, Fire Hydrants, Gasholders. &c.

Office No. 6 North Seventh Street, Philadelphia.

MATTHEW ADDY, President.

W. L. DAVIS, Selling Agent.

GEO. P. WILSHIRE, Sec. & Treas.

Cincinnati and Newport Iron and Pipe Company,

NEWPORT, KY.

Lamp Posts

AND

BENCH CASTINGS

A Specialty.

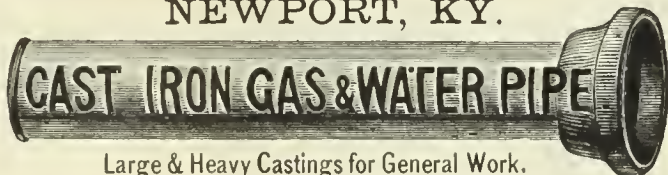

Large & Heavy Castings for General Work.

Manufacture Pipe from 2 to 48 inches. All work guaranteed first quality.

Branch

AND

SPECIAL CASTINGS

FOR GAS & WATER CO'S.

Pancoast & Rogers.

WROUGHT IRON PIPE,

VALVES AND GATES,

Cast Iron Gas & Water Pipe.

28 Platt and 15 Gold St., New York.

Water & Gas Pipe.

RUSTLESS

Send for New Catalogue.

RUSTLESS

The **WELLS RUSTLESS IRON COMPANY,**
Nos. 7 and 9 Cliff Street, New York City.

The Management of Small Gas Works.

By C. J. R. HUMPHREYS. Price, \$1.

A running commentary on the different sections of gas management with reference to small undertakings, with some notes on the erection of the necessary plant.

A. M. CALLENDER & CO., 42 Pine St., N. Y.

MELLERT FOUNDRY & MACHINE CO., Ltd.

Reading, Pa.



Specials—Flange Pipe, Valves and Hydrants, Lamp Posts, Retorts, etc.

General Foundry and Machine Work.

JOHN FOX, Selling Agent. 160 Broadway, N. Y.

THE OHIO PIPE COMPANY,

MANUFACTURERS OF

Cast Iron Gas & Water Pipe,

BRANCH AND SPECIAL CASTINGS.

Gas-House Bench Castings, Hydraulics, Lamp Posts, Flange Pipe and Specials, Architectural Castings, Building Columns, Joists, Cellar Grates, Sash Weights, etc.

GENERAL FOUNDERS AND MACHINISTS.

Columbus, Ohio.

M. J. DRUMMOND,



SPECIAL CASTINGS AND LAMP POSTS.

Equitable Building, 120 Broadway, N. Y.

JOS. R. THOMAS, C.E.,

May be Consulted on all Matters Relating to Gas Works and Gas Manufacture.

ADDRESS THIS OFFICE.

WM. MOONEY

(Successor to WM. FARMER)

27 Pearl Street, N Y. City.

(One door from Whitehall Street.)

CONTRACTOR FOR THE ERECTION OF GAS WORKS, OR APPARATUS OF ANY CAPACITY. AGENT FOR

WM. FARMER'S PATENTS.

Plans and Specifications Furnished.

WM. HENRY WHITE,

CONSULTING AND CONSTRUCTING

Gas Engineer & Contractor

Estimates, Plans, and Specifications furnished for new works or extensions of existing works.

No. 32 Pine Street, New York City.

Correspondence solicited.

WM. GARDNER,

Gas Engineer,

Lewis Block, Room 20, Pittsburgh, Pa.

Those who intend to make alterations in existing gas plants, or who contemplate the erection of new works, will find it to their interest to open correspondence with the above. Plans made and estimates furnished.

GAS LAMPS.

SCRUBBERS AND CONDENSERS.

The Siemens and Lungren REGENERATIVE GAS LAMPS.

A System of Burning Gas whereby its Illuminating Power is Increased from 300 to 400 per ct. without the Expense, Trouble and Annoyance resulting from the use of Hydrocarbon Enriching Material.

The Siemens-Lungren Company received the only Silver Medal or Highest Award for Gas Burners at the "Novelties" Exhibition of the Franklin Institute, held at Phila., Oct., '85.

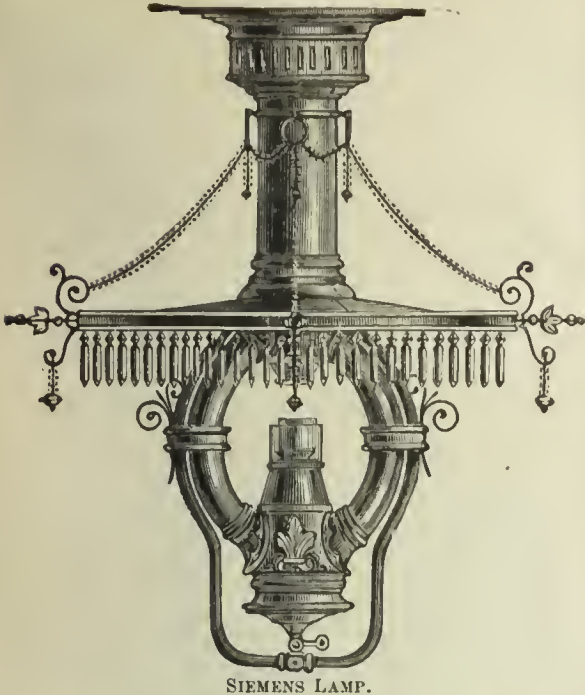

SIEMENS LAMP.

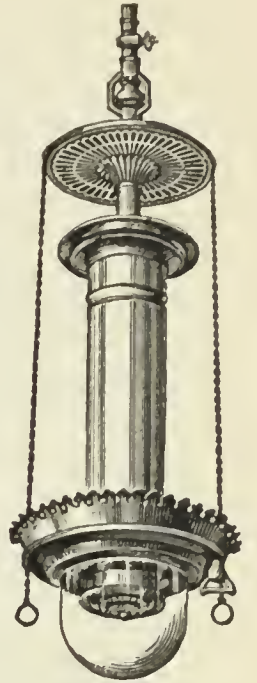

LUNGREN LAMP

THIRTEEN CANDLE POWER PER CUBIC FOOT OF GAS!

This result is obtained

SIMPLY BY THE SCIENTIFIC APPLICATION OF THE REGENERATIVE PRINCIPLE.

Consequently this largely increased illumination is always maintained without further cost and frequent attention

THE SIEMENS-LUNCREN COMPANY,

N. E. Cor. 21st. St. and Washington Av., Phila. Pa.

KIRKHAM, HULETT & CHANDLER, Limited,
London, S. W., England.

PATENT "STANDARD" WASHER-SCRUBBERS.

Following are extracts from letters received from some of the Gas Light Companies now using the "Standard" Washer-Scrubber:

CONSOLIDATED GAS CO. OF NEW YORK,
METROPOLITAN WORKS, NEW YORK, Aug. 27, 1887. }

GEO. SHEPARD PAGE, Esq.:

Dear Sir—In reply to yours, would say that the "Standard" Washer-Scrubber at these Works continues to operate satisfactorily.

Respectfully yours,

WM. B. LUNDIE, Supt.

DORCHESTER, MASS., Sept. 1, 1887.

MR. GEO. S. PAGE:

Dear Sir—In answer to yours, I can freely say that I think the "Standard" Scrubber an excellent machine. With it we can easily remove all of the ammonia from the gas.

Yours truly,

CHAS. D. LAMSON,
Boston Gas Light Co.

PROVIDENCE, R. I., Sept. 5, 1887.

GEORGE SHEPARD PAGE, Esq.:

Dear Sir—In answer to yours, would say that the "Standard" continues to give good satisfaction.

Yours truly,

A. B. SLATER, Treas.,
Providence Gas Co.

HALIFAX, N. S., Sept. 10, 1887.

GEORGE SHEPARD PAGE, Esq.:

Dear Sir—In reply to yours, I have to say that your "Standard" Washer-Scrubber continues to give entire satisfaction.

Yours truly,

BOBT. BAXTER, Manager,
Halifax Gas Light Co.

GEO. SHEPARD PAGE, 69 WALL STREET, NEW YORK,

Agent for the Western Hemisphere.

GAS WORKS APPARATUS AND CONSTRUCTION.

GAS WORKS APPARATUS AND CONSTRUCTION.

WORKS: { MILLVILLE, N. J.
FLORENCE, "
CAMDEN, "

R. D. WOOD & CO.,

OFFICES: { 400 CHESTNUT ST.,
PHILADELPHIA.

GAST-IRON PIPE 1½ to 72 Inches in Diameter.

Water Machinery and Gas Apparatus.

HEAVY CASTINGS.

HOLDERS,

PURIFIERS,

FLOORS AND ROOFS,

LAMP POSTS,

CONDENSERS,

FLANGED PIPE,

VALVES,

BENCH WORK,

FIRE HYDRANTS,

METER CASES.

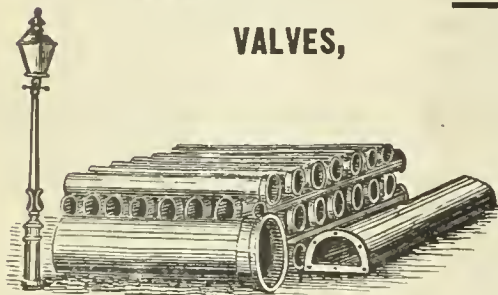

Estimates and Specifications for
NEW WORKS or **EXTENSIONS**
or **ALTERATIONS** of **OLD ONES.**

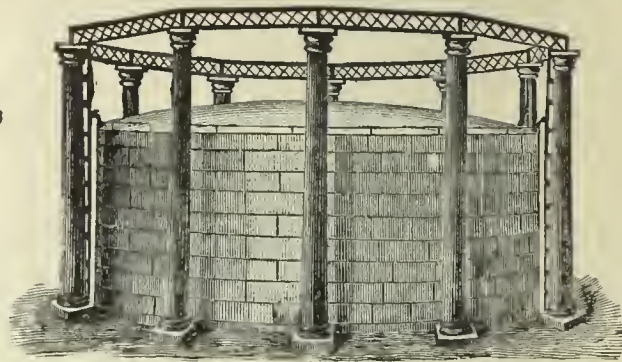

GASHOLDER TANK CONSTRUCTION, ETC.

Gas Companies and others about to erect Gasholders will find it profitable to consult W. C. WHYTE, who for over thirty years has made a specialty of

Holder Tank Excavation and Mason Work.

Fifty tanks now in operation show the sort of work done. Address

W. C. WHYTE, No. 15 Cortlandt St., N. Y. City.

MORRIS, TASKER & CO.,

Limited,

Builders of Gas Works,

PHILADELPHIA PA.

GASHOLDERS, PURIFIERS, SCRUBBERS, CONDENSERS, EXHAUSTERS,
Bench Castings, Iron Roofs, Lamp Posts,
VALVES, STREET MAIN SPECIALS, ETC.,

MANUFACTURED BY

KERR MURRAY MANUFACTURING COMPANY.

From 1880 to 1886, inclusive, we erected Gasholders for the following cities, viz.:

Adrian, Mich.	East End Gas Co., Pitts-	Janesville, Wis.	New Cas le, Pa.	Valparaiso, Ind.
Akron, Ohio.	burgh, Pa.	Johnstown, Pa.	Niagara Falls, N. Y.	Van Wert, Ohio.
Albuquerque, N. M.	East Saginaw, Mich.	Key West, Fla.	Osawatomie, Kans.	Wabash, Ind.
Altoona, Pa.	Elgin, Ills.	La Crosse, Wis.	Pittsburgh, Pa. (2)	Waco, Texas.
Anderson, Ind.	Evanston, Ills.	Lebanon, Ind.	Plainfield, Ind.	Waukesha, Wis.
Bellaire, Ohio.	Eufaula, Ala.	Lima, Ohio.	Portage City, Wis.	Wheeling, West Va.
Birmingham, Ala.	Frankfort, Ind.	Logan, Ohio.	Sedalia, Mo.	Wellington, Kans.
Bucyrus, Ohio.	Freeport, Ills.	Louisville, Ky.	Sheboygan, Wis.	West Pittsburgh, Pa.
Canton, Ohio.	Galesburg, Ills.	Mankato, Minn.	South Bend, Ind.	Xenia, Ohio.
Circleville, Ohio.	Grafton, West Va.	Mansfield, Ohio.	South Chicago, Ills.	Youngstown, Ohio.
Colorado Springs, Col.	Greensburg, Pa.	Marshalltown, Iowa.	Springfield, Ills.	Ypsilanti, Mich.
Danbury, Conn.	Huntington, Ind. (2)	Meridian, Miss.	Streator, Ills.	
Delaware, Ohio.	Ironton, Ohio.	Minneapolis, Minn.	Topeka, Kans.	
Delphos, Ohio.	Jamestown, N. Y.	Muskegon, Mich.	Uniontown, Pa.	

Under construction, 1887.

Arkansas City, Kans.	Grand Forks, Dakota.	Mobile, Ala.	Santa Fe, N. M.	Fuel Gas and Electric Engi-
Dallas, Texas.	Grand Rapids, Mich.	Pittsburgh, Pa.	Wichita, Kans.	neering Co., Pittsburgh, Pa.
El Paso, Texas.	La Crosse, Wis.	Pine Bluff, Ark.	Lexington, Mo.	Stillwater, Minn.

Estimates, with Plans and Specifications, for new or the rebuilding of old works, furnished on application. Correspondence solicited. Address

KERR MURRAY MANUFACTURING CO.,

A. D. CRESSLER, General Manager.

FORT WAYNE, IND.

GAS WORKS APPARATUS AND CONSTRUCTION.

GAS WORKS APPARATUS AND CONSTRUCTION.

JAMES R. FLOYD,

(SUCCESSOR TO HERRING & FLOYD)

Oregon Iron Works,

531 to 543 West 20th St., N. Y.

Practical Builders of Gas Works,

MANUFACTURERS OF

**ALL KINDS OF CASTINGS
AND
APPARATUS FOR GAS-WORKS.**

BENCH CASTINGS

from benches of one to six Retorts each.

**WASHERS: MULTITUBULAR AND
AIR CONDENSERS; CONDENSERS;
SCRUBBERS**

(wet and dry), and

EXHAUSTERS

for relieving Retorts from pressure.

BENDS and BRANCHES

all sizes and description.

FLOYD'S PATENT

MALLEABLE RETORT LID.

PATENT

SELF-SEALING RETORT LIDS.

FARMER'S

PATENT BY-PASS DIP-PIPE.

SABBATON'S PATENT

FURNACE DOOR AND FRAME.

BUTLER'S

COKE SCREENING SHOVELS.

GAS GOVERNORS,

and everything connected with well regulated Gas Works at low price, and in complete order.

SELLER'S CEMENT

for stopping leaks in Retorts.

N. B.—**STOP VALVES** from three to thirty inches—at very low prices.

Plans, Specifications, and Estimates furnished.

GAS vs. ELECTRIC LIGHT.

We would invite attention to the able and exhaustive argument of General A. Hickenlooper, President of the Cincinnati Gas Light and Coke Company, contained in a handsome pamphlet of 96 pages, entitled

"**EDISON'S INCANDESCENT ELECTRIC LIGHTS FOR STREET ILLUMINATION. REPORT OF AN ARGUMENT DELIVERED BY A. HICKENLOOPER BEFORE THE COMMITTEE ON LIGHT, MUNICIPAL COUNCIL, CITY OF CINCINNATI, JULY 22, 1886.**"

This is a subject of special interest to all Gas Light Companies.

Prices.

25 copies..... \$7.50 100 copies..... \$22.50
50 copies..... 12.50 250 copies..... 50.00

A sample copy will be sent by mail on receipt of 50 cts.

A. M. CALLENDER, & CO., 42 PINE ST., N. Y. CITY.

THE CONTINENTAL IRON WORKS.

THOS. F. ROWLAND, Prest. WARREN E. HILL and CHAS. H. CORBETT, V.-Presds. THOS. F. ROWLAND, JR., Sec. & Treas.



GAS HOLDERS OF ANY MAGNITUDE.

P. O. Station G., BROOKLYN, N. Y.

ENGINEERS AND MANUFACTURERS OF

Gas Holders

CONDENSERS, SCRUBBERS, VALVES,

PURIFIERS, SELF-SEALING RETORT LIDS,

Hydraulic Mains,

And all other articles connected with the manufacture and distribution of Gas.

H. RANSHAW, Prest. & Mangr. WM. STACEY, Vice-Prest. T. H. BIRCH, Asst. Mangr. R. J. TARVIN, Sec. & Treas.

STACEY MFG. CO.,

MANUFACTURERS OF

Single and Telescopic Gasholders,

IRON ROOFS, BRIDGES, LAMP POSTS,

Water and Oil Tanks, Coal Elevator Cars,

COKE CRUSHERS, BENCH CASTINGS,

And all kinds of Wrought and Cast Iron Work used in the erection of Coal and Oil Gas Works. Rolling Mill Machinery and Heavy Castings a Specialty.

Foundry:

33, 35, 37 & 39 Mill Street.

Wrought Iron Works:

16, 18, 20, 22, 24 & 26 Ramsey Street.

Cincinnati, Ohio.

1842. **DEILY & FOWLER,** 1887

Laurel Iron Works.

Address, No. 39 Laurel Street, Philadelphia, Pa.

MANUFACTURERS OF

GASHOLDERS,

Single and Telescopic.

HOLDERS Built 1882 to 1886, Inclusive:

- | | | | | |
|----------------------------|--------------------------|----------------------------|----------------------------|---------------------------|
| Denver, Col. | Warren, Ohio. | Allegheny, Pa. (21.) | York, Pa. | Salem, N. J. (2d) |
| Chicago, Ill. (West Side). | Bath, N. Y. | Atlanta, Ga. (2d.) | Chester, Pa. | Omaha, Neb. (2d) |
| Pittsburgh, Pa. (S. Side) | Lynn, Mass. | N.Y. City (Central Gas Co) | Hazleton, Pa. (2d.) | Lynn, Mass. (2d) |
| Pawtucket, R. I. | New Bedford, Mass. | Lynchburg, Va. (2d.) | Staten Island, N. Y. | Little Rock, Ark. |
| Brookline, Mass. | Waterbury, Conn. | Saylesville, R. I. | Saugerties, N. Y. | Irvington, N. Y. |
| Sherbrooke, Can. | Deseronto, Can. | Rondout, N. Y. | Clinton, Mass. (Lao Mills) | South Boston, Mass. |
| Burlington, N. J. (2d.) | Hoosic Falls, N. Y. (2d) | Atlantic City, N. J. | Chattanooga, Tenn. | Rye, N. Y. (2) |
| Bridgeton, N. J. | Bethlenem, Pa. | Augusta, Ga. | Galveston, Texas. (3d.) | Woodstock, Ont. |
| Bay City, Mich. | Atlanta, Ga. (1st.) | Waltham, Mass. (2) | Omaha, Neb. | Malden, Mass. |
| Erie, Pa. | Savannah, Ga. | Mahanov City, Pa. | Fort Plain, N. Y. | Staten Island, N. Y. (2d) |
| Jackson, Mich. | Montgomery, Ala. | New Castle, Pa. | Brunswick, Ga. | |
| Kalamazoo, Mich. (3d.) | Newport, R. I. | Long Island City, N. Y. | Port Chester, N. Y. | |
| Glen Island, N. Y. | Portland, Oregon. | Macon, Ga. | New Rochelle, N. Y. | |

SMITH & SAYRE MFG. COMPANY,

G. PORTER, Prest.

245 Broadway, N. Y.

CHAS. W. ISBELL, Sec'y.

Machinery & Apparatus for Gas Works

Drawings, Plans, and Estimates Furnished for the Improvement, Extension, or Alteration of Gas Works, or for the Construction of New Works.

Mackenzie's Patent Rotary and Steam Jet Gas Exhausters, Governors, Compensators, Condensers, Washers, Scrubbers. Isbell's Patent Automatic Street Pressure Governor Gas and Water Valves, Hydraulic Main Dip Regulator, Bench Castings, etc. Purifying Boxes and "Standard" Scrubbers. Isbell's Patent Self-Sealing Retort Doors.

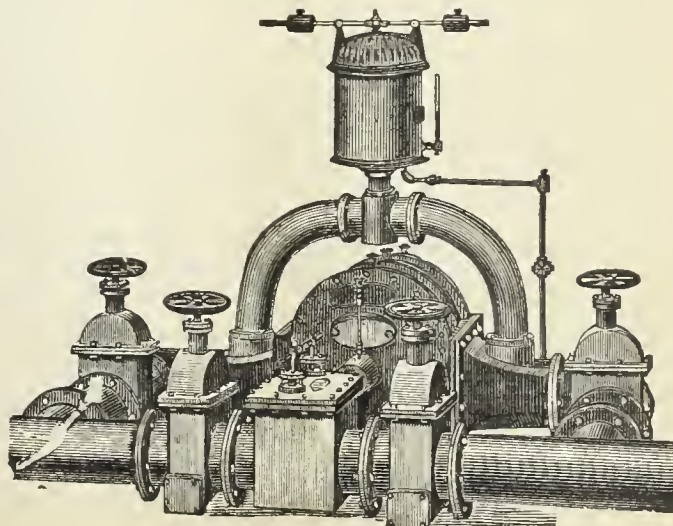

GAS COALS.

CANNEL COALS.

GAS ENRICHERS.

JAMES D. PERKINS.

PERKINS & CO.,

F. SEAVERN.

General Sales Agents for

The Youghiogheny River Coal Company's

OCEAN MINE YOUGHIOGHENY GAS COAL.

The Coal from the Ocean Mine (recently operated by *Messrs. W. L. Scott & Co.*, of Erie, Pa.,) is now used by all the leading Gas Companies in the United States from Maine to Texas, and is recognized as *the only reliable Youghiogheny Gas Coal.* (See Map on p. 87 of this Journal, Feb. 16, '85.)

P. O. Box 3695,
New York.

PERKINS & CO., 228 and 229 N. Y. Produce Exchange.

BEAVER STREET
ENTRANCE.

BRECKENRIDGE CANNEL, OF KENTUCKY.

This Colliery was re-opened in June, 1886, since which date the Cannel has been delivered to over sixty of the leading Gas Companies in this country and in Europe. As an enricher ONE TON of this Cannel will do the work of TWO TONS of any other available Cannel, and is more economical than Naptha or Oil of any character. It can be delivered in parcels of one car load or more to any point in the United States or Canada.

(See AMERICAN GAS LIGHT JOURNAL, June 16, '86, pp. 346-7.)

P. O. Box 3695,
New York.

PERKINS & CO., 228 and 229 N. Y. Produce Exchange

BEAVER STREET
ENTRANCE.

JAMES & WILLIAM WOOD, Gas and Cannel Coal Contractors,

No. 40 St. Enoch Sq., Glasgow. No. 2 Talbot Court, London.

Proprietors of the BATHVILLE COLLIERIES (which produce the celebrated BOGHEAD CANNEL), Shields, Shieldmuir, Drumpeller, and other Collieries. This Firm offer

STANDARD CANNELS, Unequaled as Gas Enrichers.

Analyses, prices, and all further information furnished on application to

Agency for U. S., Room 93, Nos. 2 & 4 Stone St, N.Y. City.

The Standard Oil Company, REFINERS OF NAPHTHA AND GASOLINES.

ALSO MANUFACTURERS OF

A Special Grade of Naptha for
Gas Companies

FOR ENRICHING COAL GAS.

Correspondence solicited.

No. 43 Euclid Avenue, Cleveland, Ohio.

To Gas Companies.

We make to order CAP BURNERS to burn any amount under a stated pressure. Send for samples.

Also, SERVICE CLEANERS, DRIP PUMPS, and STREET MAIN PROVING APPARATUS.

C. A. GEFROERER,

248 N. 5th Street, Phila., Pa.

GOODWIN'S DIRECTORY

OF THE GAS LIGHT COMPANIES of the UNITED STATES & CANADA.

Price, \$10.00.

Orders may be sent to

A. M. CALLENDER & CO., No. 42 Pine Street, N. Y. City.

COKE CRUSHERS.

GAS COALS.

GAS COALS.

Newburgh Orrel Coal and Coke Co.

MINERS AND SHIPPERS OF

Mountain Brook Steam and Smithing Coals,

**NEWBURGH, PALATINE,
AURORA & TYRCONNELL
GAS COALS.**

Foundry & Crushed Coke Shipped Direct from Ovens

Mines Situated at

Newburgh, Flemington & Fairmont, W.Va.

HOME OFFICE,

33 S. Gay St., Baltimore.

CHAS. MACKALL, Gen. Mangr.

CHAS. W. HAYS, Agent in New York,

Room 147, WASHINGTON BUILDING, No. 1 Broadway.

Shipping wharves at Locust Point, Baltimore.

THE DESPARD COAL COMPANY

OFFER THEIR SUPERIOR

DESPARD COAL

To Gas Light Companies and Manufacturers of Fire Clay Goods
Throughout the Country.

ROUSSEL & HICKS, } AGENTS. { BANGS & HORTON,
71 Broadway, N. Y. } 16 Kilby St., Boston.

Mines in Harrison Co., West Va. Wharves, Locust Point, Balt.

Company's Office, 15 German St., Baltimore, Md.

Among the consumers of Despard Coal we name: Manhattan
Gas Light Co., N. Y.; Metropolitan Gas Light Co., N. Y.; Jersey
City, (N. J.) Gas Light Co.; Washington (D. C.) Gas Light Co.;
Portland (Maine) Gas Light Co. Reference to them is requested.

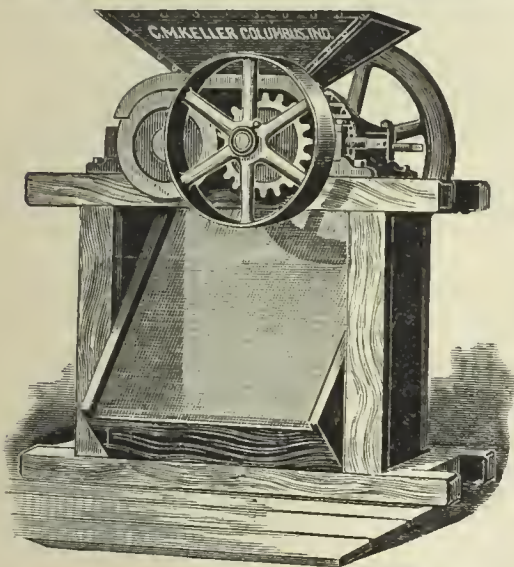

Keller's Adjustable Coke Crusher

SIMPLE, STRONG, AND DURABLE.

C. M. Keller, Sec. & Supt. Gas Lt. & Coke Co. Columbus, Ind.

Correspondence Solicited.

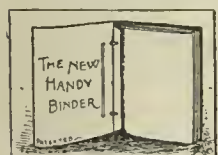

**THE NEW
HANDY BINDER.**

This article may be described as elegant
in appearance, strong, durable, and possessing many special
qualities of its own. It allows the opening of the pages per-
fectly flat, whether one or several numbers are in the binder.
Any number can be taken out and replaced without disturbing
the others. The papers are not mutilated for subsequent bind-
ing in permanent form. The binder is supplied with gilt side
title, and is an ornament to any desk or reading table. The
JOURNAL, filed in the Handy Binder, becomes a volume of great
value, always convenient for instant reference. Handy Binder,
Postage paid, \$1 00.

A. M. CALLENDER & CO., 42 Pine St., N. Y.

THE
PENN GAS COAL CO.

OFFER THEIR

Coal, Carefully Screened & Prepared for Gas Purposes.

Their Property is located in the Youghiogheny Coal Basin, near Irwin and Penn Stations on the
Pennsylvania Railroad, and on the Youghiogheny River.

Principal Office:

209 SOUTH THIRD STREET, PHILA., PA.

Points of Shipment:

Pennsylvania Railroad Piers; Greenwich Wharves, Delaware
River; Pier No. 1 (Lower Side), South Amboy, N. J.

Chesapeake & Ohio Railway Coal Agency,

FOR THE SALE OF THE

**Superior Kanawha Gas Coals, Cannelton Cannel,
Also, SPLINT AND STEAM COALS.**

From the Kanawha and New River Regions, on the line of the Chesapeake & Ohio R'way.

C. B. ORCUTT, Sales Agent. | OFFICE, 150 BROADWAY, N Y

FRANCIS H. JACKSON, Prest. EDmund H. McCULLOUGH, V.-Prest. CHAS. F. GODSHALL, Treas. H. C. ADAMS,

THE WESTMORELAND COAL CO.

Chartered 1854.

**Mines situated on the Pennsylvania and the Baltimore
and Ohio Railroads, in Westmoreland County, Penn.**

POINTS OF SHIPMENT:

PHILADELPHIA, BALTIMORE, SOUTH AMBOY, N. J.,
WATKINS (SENECA LAKE), N. Y.

Since the commencement of operations by this Company its well-known
Coal has been largely used by the Gas Companies of New England and the
Middle States, and its character is established as having no superior in gas
giving qualities, and in freedom from sulphur and other impurities.

Principal Office, 224 South 3d St., Phila., Pa.

A. M. SCOTT, PRESIDENT. A. DEMPSTER, C.E., SECRETARY. W. K. GILLESPIE, TREASURER.

MONONGAHELA AND PETERS CREEK GAS COAL CO.,

PRODUCERS OF

Coal Bluff Gas Coal.

MINES LOCATED ON THE MONONGAHELA DIVISION OF THE PENNSYLVANIA RR.,
IN THE CENTRAL PORTION OF THE PITTSBURGH COAL FIELD.

Points of Shipment—Buffalo, Cleveland, Erie, Chicago, New Orleans.

Since the introduction of Coal Bluff Gas Coal it has taken rank among the few first-class Gas Coals, and ac-
knowledges no superior in gas-giving qualities, ease of working, quality of coke, and freedom from impurities.

Milwaukee Agents, F. R. BUELL & CO., - - - Milwaukee, Wis.

General Office, 43 Sixth Ave., Pittsburgh, Pa.

GAS METERS.

GAS METERS.

GAS METERS.



INTERNATIONAL--1876--EXHIBITION.

The U. S. Centennial Commission

HAVE DECREED AN AWARD TO

HARRIS, GRIFFIN & CO.,

Twelfth and Brown Streets, Philadelphia, Pa. No. 49 Dey Street, N. Y. City, and No. 75 North Clinton Street, Chicago, Ill.

FOR THE FOLLOWING REASONS:

The Exhibit consists of a Series of METERS from the Largest Size Station Meters for the use of the MANUFACTURE OF GAS, to those for the use of the ORDINARY CONSUMER. The Instruments are WELL MADE, RELIABLE as to INDICATION, and embody a number of sundry improvements which, with the general character of the Exhibit, entitle the whole to commendation.

Attest—J. L. CAMPBELL,
Secretary. pro-tem

Signed—A. T. GOSHORN,
Director General

J. R. HAWLEY,
President

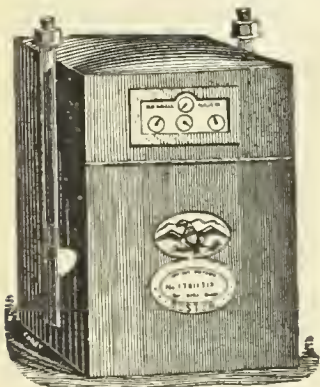

Dry Gas Meter.

With 39 years' experience and the best facilities for manufacturing, is enabled to furnish reliable work and answer orders promptly.

NATHANIEL TUFTS,

No. 153 Franklin Street, Boston, Mass.,

MANUFACTURER OF

DRY GAS METERS.

Station Meters of any Capacity.

Test and Experimental Meters, Pressure Registers, Pressure Gauges, Pressure and Vacuum Gauges.

METER PROVERS, PHOTOMETERS, STREET LANTERNS, ETC., ETC.

Patent Cluster Lanterns for Street Illumination.

SCIENTIFIC BOOKS.

We are prepared to furnish to Gas Managers, and others interested in the topics treated of, the following books, at prices named:

KING'S TREATISE ON THE MANUFACTURE OF COAL GAS. Three vols.; \$10 per vol.	PRACTICAL TREATISE ON HEAT, by THOMAS BOX. Second edition. \$5.	THE GAS MANAGER IN THE LABORATORY, by a Practical Student. 8vo., Cloth. \$1.50.
GAS MANUFACTURE, by WILLIAM RICHARDS. 4to., with numerous Engravings and Plates, in Cloth binding. \$12.	GAS WORKS—THEIR ARRANGEMENT, CONSTRUCTION, PLANT, AND MACHINERY. \$8.	THE DOMESTIC USES OF COAL GAS, AS APPLIED TO LIGHTING, by W. SUGG. \$1.40.
THE GAS ANALYST'S MANUAL, by F. W. HARTLEY. \$2.50.	COAL; ITS HISTORY AND USE, by PROF. THORPE. \$3.50.	DISTILLATION OF COAL TAR AND AMMONIACAL LIQUOR by GEO. LUNGE. \$8.50.
TECHNICAL GAS ANALYSIS. \$2.80.	THE GAS WORKS OF LONDON, by COLBURN. 60 cents.	A TREATISE ON THE COMPARATIVE COMMERCIAL VALUES OF GAS COALS AND CANNELS, by D. A. GRAHAM 8vo., Cloth. \$3.
GAS MANAGER'S HANDBOOK, by THOS. NEWBIGGING. \$4.80.	THE GAS FITTER'S GUIDE, Showing the Principles and Practice of Lighting with Coal Gas, by JOHN ELDRIDGE. 40 cents.	GAS AS A SOURCE OF LIGHT, HEAT, AND POWER, by C. J. R. HUMPHREYS. 10 cents.
GAS CONSUMER'S GUIDE. \$1.	GAS WORKS, AND MANUFACTURING COAL GAS, HUGHES. \$2.20.	GAS COMPANIES DIRECTORY. \$10.
A GUIDE TO GAS LIGHTING. 40 cents.	THE MANAGEMENT OF SMALL GAS WORKS, by C. J. R. HUMPHREYS. \$1.	GAS VERSUS ELECTRIC LIGHT. 50 cents.
GAS MEASUREMENT AND GAS METER TESTING, by F. W. HARTLEY. \$1.60	MANUAL FOR GAS ENGINEERING STUDENTS, by D. LEE, 40 cents.	PURIFICATION OF COAL GAS, by R. P. SPICE. 8vo. \$3.
GAS CONSUMER'S HANDBOOK, by WILLIAM RICHARDS, C.E.; 18mo., Sewed. 20 cents.	HOW TO MANAGE GAS, by F. WILKINS. Paper. 20 cents.	
A PRACTICAL TREATISE ON GAS AND VENTILATION with Special Relation to Illuminating, Heating, and Cooking by Gas, by E. E. PERKINS. \$1.25.		

The above will be forwarded by express, upon receipt of price. We take especial pains in securing and forwarding any other Works that may be desired, upon receipt of order. All remittances should be made by check, draft, or post office money order.

A. M. CALLENDER & CO., No. 42 Pine Street, New York.

KING'S TREATISE ON COAL GAS.

The most complete work on Coal Gas ever published. Three vols., bound \$30.

A. M. CALLENDER & CO., No. 42 Pine Street, New York,

GAS METERS.

GAS METERS.

GAS METERS.

GEO. J. MCGOURKEY, Pres. WM. H. MCFADDEN, Vice-Pres. (Phila.) WM. N. MILSTED, Gen. Supt. & Treas. (New York) WM. H. DOWN, Sec.

AMERICAN METER COMPANY,

WET AND DRY GAS METERS.

PRESSURE REGISTERS.

METER PROVERS.

STATION METERS.

PRESSURE & VACUUM REGISTERS.

PORTABLE TEST METERS.

EXHAUSTER GOVERNORS.

PRESSURE & VACUUM GAUGES.

EXPERIMENTAL METERS.

DRY CENTRE VALVES.

CRESSON GAS REGULATORS.

AMMONIA TEST METERS.

GOVERNORS FOR GAS WORKS.

MARSLAND WATER METERS.

BAR AND JET PHOTOMETERS

Manufactories:

512 W. 22d St., N. Y.
Arch & 22d Sts., Phila.

GAS STOVES,

SUGG'S "STANDARD" ARGAND BURNERS,
SUGG'S ILLUMINATING POWER METER,
Wet Meters, with Lizar's "Invariable Measuring" Drum.

Agencies:

177 Elm Street, Cincinnati.
214 & 216 N. Wells Street, Chicago.
810 North Second Street, St. Louis.
222 Sutter St., San Francisco.

HELME & McILHENNY,

(Successors to Harris & Brother. Established 1848.)

GAS METER MANUFACTURERS,

CONTINUE AS HERETOFORE AT THE OLD ESTABLISHMENT,

Nos. 1339 to 1349 Cherry Street, Philadelphia, Pa.,

To Manufacture Wet and Dry Gas Meters, Station Meters, Experimental Meters, Meter Provers, Center Seals, Pressure Registers
GOVERNORS, INDICATORS, PHOTOMETERS, & ALL OTHER KINDS OF APPARATUS FOR USE IN GAS WORKS.

From our long practical experience of the business, and from our personal supervision of all work, we can guarantee all orders to be executed promptly and in every respect satisfactorily.

WM. WALLACE GOODWIN, Prest. and Treas.

WM. H. MERRICK, V.-Prest.

S. L. JONES, Sec.

S. V. MERRICK, Supt.

THE GOODWIN GAS STOVE AND METER COMPANY,

Successors to W. W. GOODWIN & CO.

1012, 1014 and 1016 Filbert St., Phila., Pa.

142 Chambers St., New York.

76 Dearborn St., Chicago, Ill.

WALDO BROS., Agents, 88 Water St., Boston.

MANUFACTURERS OF THE "SUN DIAL" GAS STOVES, FOR COOKING AND HEATING PURPOSES.

Dry and Wet GAS METERS, Station Meters (Square, Cylindrical, or in Staves) Glazed Meters, King's and Sugg's Experimental Meter Lamp Post Meters, Etc., Etc., Meter Provers (sizes 2, 5 and 10 feet), Pressure Gauges of all kinds, Pressure Registers, Pressure and Vacuum Registers, Pressure Indicators (sizes 4 inch, 6 inch and 9 inch), King's Pressure and Vacuum Gauges, Dry and Wet Centre Seals, Dry and Wet Governors, Exhauster Governors, Photometers of all descriptions. Letheby's Sulphur and Ammonia Test Apparatus complete—also Testing and Chemical Apparatus of all kinds, and of the most perfect description, for all purposes relating to Gas.

GOODWIN'S IMPROVED LOWE'S JET PHOTOMETER.

Agents for Bray's Patent Gas Burners and Lanterns.

Special attention to repair of Meters, and all apparatus connected with the business.
All work guaranteed first class in every particular, and orders filled promptly.

G. B. EDWARDS, Mang'r, New York.
E. H. B. TWINING, Mang'r, Chicago.
Represented by S. S. STRATTON.

D. McDONALD & CO.,

GAS METER MANUFACTURERS.

(Established 1854.)

51 Lancaster St., Albany, N. Y.

34 & 36 West Monroe St., Chicago, Ill.

STATION METERS, EXPERIMENTAL METERS, METER PROVERS, PRESSURE & VACUUM REGISTERS, PRESSURE GAUGES, ETC.

Also STAR GAS STOVES, RANGES, and HEATING STOVES.

We use only the very best materials, and employ the most skilled labor, and by our long experience (32 years) and personal supervision of every detail, we feel justified in assuring the public that our goods will give perfect satisfaction. Every Meter emanating from our establishment will bear the State Inspector's BADGE, and will be fully warranted by us. Our Annual and Calendar will be sent to Gas Companies upon application.

GAS STOVES.

GAS STOVES.

GAS STOVES.

THE GOODWIN GAS STOVE AND METER CO.,

1012-18 Filbert St., Phila., 142 Chambers St., N. Y., 76 Dearborn St., Chicago.

Agents, WALDO BROTHERS, 88 Water Street, Boston.

WM. W. GOODWIN, PRES. & TREAS.
W. H. MERRICK, VICE-PRES.
S. LEWIS JONES, SEC.
SAMUEL V. MERRICK, SUPT.

SOLE MANUFACTURERS OF THE

G. B. EDWARDS, Mang'r, N. Y.
E. H. B. TWINING, Mang'r, Chicago.
Represented by S. S. STRATTON.

"SUN DIAL" GAS STOVES

The Most Economical, Efficient, and Durable Gas Stove Made.

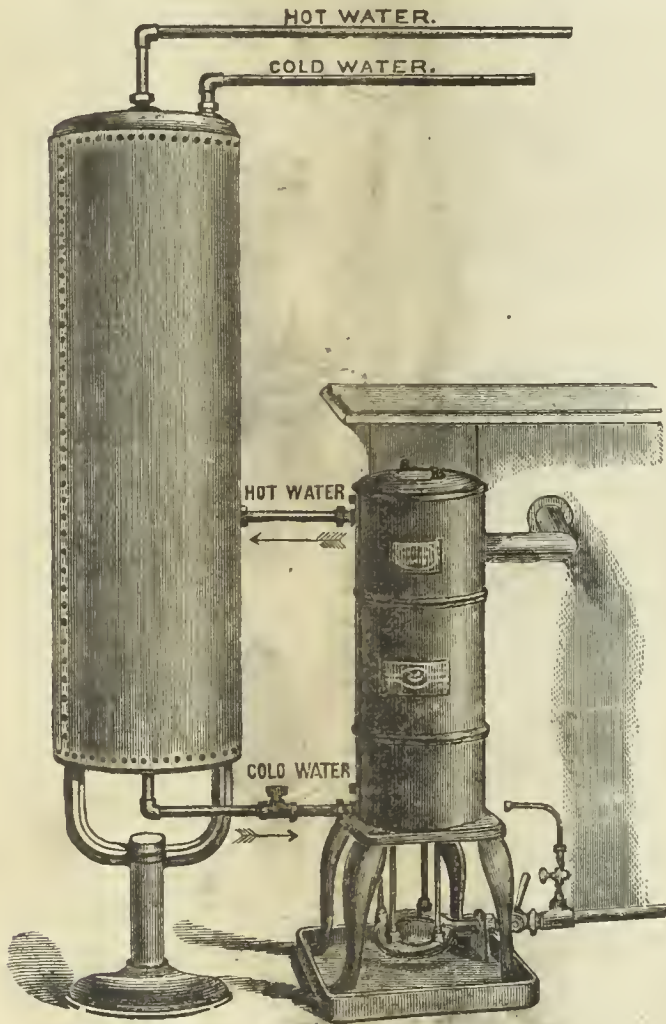

I.—Safety Hot Water Generator and Boiler.

Safety Hot Water Generator and Boiler.

Cut I. represents our Safety Gas Hot Water Generator and Boiler, arranged for home use. This most easy, quick, and economical way of preparing a warm bath, or for heating water for any domestic purpose, entirely supersedes any necessity for the use of ranges or stoves—a great comfort, particularly in hot weather. The boiler being self-filling, as the hot water is drawn off, can never become empty, thus preventing the possibility of any accident.

We beg to call attention to the cast iron pan which is now attached to the legs of the Generator (see illustration). This is to catch the drippings from the Coil, which many persons suppose come from a leak, when in fact they are produced by condensation. This condensation caused by the hot flame coming in contact with the coil filled with cold water.

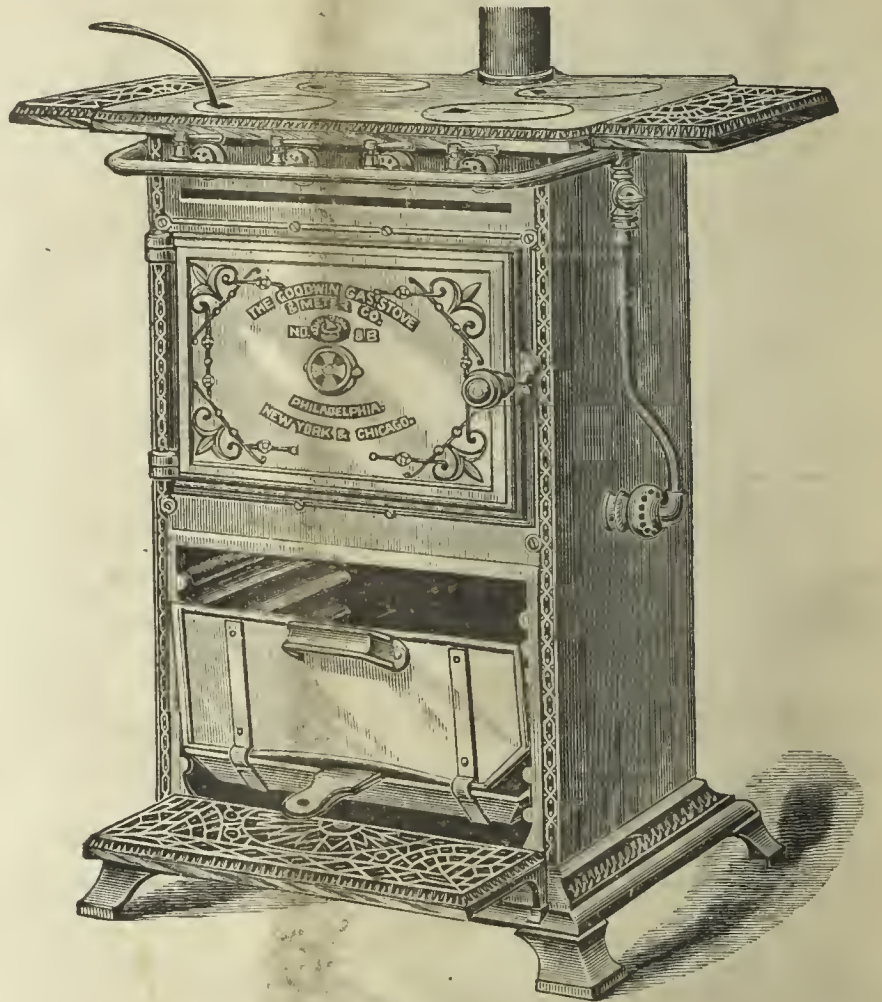

II.—Gas Cooking Stove No. 8 B.

New Style Gas Cooking Stove.

Cut II. represents our New Style Cooking Stove. As will be seen, it has an ornamented cast iron base and front, and extensive shelves. The oven burner, which is atmospheric (unless otherwise ordered), is of an entirely new and improved pattern (patent applied for). The ovens are of greater capacity than those of the old style. The top, in conjunction with the outlet pipe, is designed to carry off all products of combustion; hence the outlet pipe must be connected with a flue, or the stove will not work properly.

This Stove has 4 boiling burners in top of hot plate. All fittings are nickel plated. We are making this style of Cooking Stove in the following sizes—viz., No. 7 B, No. 8 B, No. 9 B, No. 10 B.

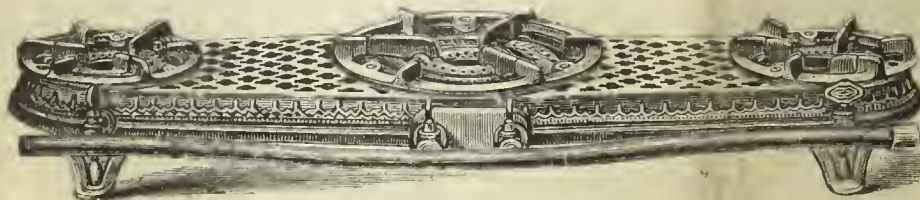

III.—Improved Hot Plate, No. 108.

New Style Hot Plates.

Cut III. represents our New Style of Hot Plates, of which we are making No. 106 (two small boiling burners), No. 107 (two medium sized boiling burners), and No. 108 (two medium and one large boiling burner). See new Catalogue and Price List for further particulars.

THE AMERICAN

GAS LIGHT JOURNAL

RODMAN & KENNY, N. Y.

PUBLISHING OFFICE No. 42 PINE STREET

DEVOTED TO THE INTERESTS OF ILLUMINATION, VENTILATION, WATER SUPPLY AND DISTRIBUTION, & GENERAL SCIENCE.

VOLUME XLVII.—No. 8.
Whole No. 680.

NEW YORK, MONDAY, OCTOBER 17, 1887.

{ \$3 PER ANNUM,
IN ADVANCE.

A. M. CALLENDER & CO., Proprietors. C. E. SANDELLSON, Manager.
JOS. R. THOMAS, C.E., Editor. T. J. CUNNINGHAM, Asst. Editor.

ENTERED AT THE POST OFFICE AT NEW YORK, N. Y.
AS SECOND CLASS MATTER.

Published on the 2d and 16th of each month, at No. 42 Pine Street, N. Y.

Terms of Subscription, Including Postage.—For the United States and Canada, \$3 per annum. European countries, \$3.50 (15 shillings—18 francs). All payments to be made in advance. Single copies, 15 cents.

CONTENTS.

An Asterisk (*) denotes an illustrated article.

OFFICIAL NOTICE—

American Gas Light Association..... 225

EDITORIALS—

Perplexities in the Chicago Gas Situation.....	225
The Final Warning.....	226
Oil and Water Gas as Illuminants.....	226
The Effect of Carbonic Acid upon the Illuminating Power of Coal Gas, by J. T. Sheard.....	227
Petroleum in Russia.....	229
Electric Lighting from Central Stations.....	231
* A Handy Machine for Piercing Gas Pipes.....	232
On the Determination of Hydrous and Anhydrous Peroxide of Iron in Irish Bog Oxide of Iron.....	232
The Dangers of Oil Lamps.....	232
* The Alavoine Plan of Hydraulic Main, as Used in the Dijon Gas Works.....	233
ITEMS OF INTEREST FROM VARIOUS LOCALITIES.....	234

Notice to Lighting Contractors—Appointed Superintendent of Lamps—Cheaper Gas for Stockton, Cal.—Public Lighting at Jersey City, N. J.—Public Lighting at Little Rock, Ark.—Making it Pleasant for the Company that Proposes to Work under the Hall Patents—Cheaper Gas for Portland, Oregon—Public Lighting at East Albany, N. Y.—A Good Exhibit—Getting Ready—Burying the Hatchet—Gas Trust (St. Louis, Mo.) Election—Appointed as Superintendent—Do the People Want it?—Public Lighting Proposals, Buffalo, N. Y.—Marysville's Plight—That Hamilton (Ohio) Suit—Annual Meeting, Concord, N. H.—Another Gas Company for San Francisco, Cal.—Objecting to the Choice Made—No Longer in Charge at Pottstown, Pa.—Contract Awarded—Changed Hands—The Sale is Off—Other Maine Gas News—Cheaper Gas for Belleville, Ontario—Public Lighting at Trenton, N. J.—What the Consolidation May Mean—A Table of Prices Paid for Arc Lights—Taxes Paid by Some New Yorkers—A Springer Apparatus for Emporia, Kansas—An Explosion at Toronto, Canada—A Maryland Company and its Purposes—Notes from the West, by "Retort"—Killed by the Current—A New Southern Enterprise.

Gas into Electricity..... 237

CORRESPONDENCE—

Tar Pavements.....	237
Western Waifs, by Diaphragm.....	238
The Market for Gas Securities.....	238

[OFFICIAL NOTICE.]

American Gas Light Association.

OCTOBER 12, 1887.

To the Members of the Association :

GENTLEMEN : The fifteenth annual meeting of the American Gas Light Association will be held, as already announced, on Wednesday, Thursday and Friday, October 19, 20 and 21. The Convention will be called to order on the morning of the first-mentioned day, at ten o'clock, by the President, Malcolm S. Greenough, Esq., of Boston.

The headquarters will be at the Sturtevant House, and accommodations for the members will also be provided at the Coleman and Grand.

The Sturtevant House is situated at the corner of Broadway and Twenty-ninth street, and is run on the American plan. The Coleman is at the corner of Broadway and Twenty-eighth street, and is run on the European system. The Grand is also on Broadway, being at the corner of Thirty-second street. It likewise is conducted on the European plan.

Members should secure rooms in advance, by writing direct to the hotel at which they intend to stop.

The meetings will be held at Doekstader's Minstrel Hall, directly opposite the Sturtevant House.

The papers so far promised are the following :

"Fuel Gas," by Emerson McMillin, of Columbus, Ohio; "Illumination vs. Candle Power," by Alex. C. Humphreys, of Philadelphia, Pa.; "Utilization of Residual Products," by Chas. H. Nettleton, of Birmingham, Conn.; "The Advantages of Gas Companies Engaging in the Electric Light Business," by E. J. King, of Jacksonville, Ill.; "Water Gas," by Walton Clark; "Development of the Half-Depth Regenerative Furnace and Some of the Results," by O. B. Weber, of New York; "The Comparative Illuminating Power of Gas Purified with Lime vs. Oxide of Iron," by C. W. Blodget, of Brooklyn, N. Y.; "Disadvantages Occasioned by Fluctuations of Candle Power in Gas Furnished to Consumers," by Richard J. Monks; "The Advantages of Regenerative Furnaces for Large and Small Gas Works," by Fred. Bredel.

We have also the partial promise of a paper treating of the value of coke for the purpose of making steam. I wish members who have any data in this direction would come prepared to give the Association the benefit of their information. I would also suggest that members be thinking over the topics contained in the foregoing list of papers, and come prepared to participate in the discussions.

Turning from the feast of reason to the lighter portion of the programme, I would remark that the banquet will be held on Thursday evening, the 20th inst., at 7:30 o'clock, at Lyrie Hall, Sixth avenue and 42d street, where we will be in the hands of a well-known New York caterer. The Committee has made such arrangements that the banquet tickets will be placed at \$3.

On Friday, the 21st inst., members of the Association and their ladies will have the privilege of participating in an excursion as the guests of the manufacturers of New York city and vicinity. The excursion will consist of a sail around the bay and up the Hudson to West Point, or as far as time will permit. The start will be made at 9 in the morning, luncheon will be served on board for the members and their lady friends, and, as the steamer chartered will be one of the Iron Steamboat fleet, the participants in the excursion may safely reckon on having an enjoyable day. The return will be made at 5:30 in the evening.

During the time of convention the Committee of Arrangements will endeavor to see that the ladies, accompanying members, shall enjoy their visit to the metropolis.

C. J. R. HUMPHREYS, Sec'y.

PERPLEXITIES IN THE CHICAGO GAS SITUATION.

According to late advices it seems as if the Chicago gas situation were becoming pretty badly muddled, and that piping times are in store for those in charge of it. We have from time to time alluded to the proposed issue of bonds, the same to become a charge on the plant and

franchises of the old Chicago Company, in its capacity as a member of the recently created Trust; and all doubt as to the purposes of those behind the scenes, in respect of the bonding scheme, was removed some time since. Now, however, we are informed that Mr. J. Edward Addicks, who is not unknown in Eastern gas circles, seeks to enjoin the Trust from issuing the bonds. Further, the City Council of Chicago is said to be about to pass a resolution condemning the franchises of the Consumers and Equitable Companies—also members of the Trust—on the ground that the provisions thereof have been violated. We have no particular desire to enter into the merits of the controversy; but it does seem to us that Mr. Addicks appears to be engaged in an attempt to lock the stable door on an empty stall. Judging the men who compose the Trust to be pretty apt financiers—and some of their prior financial efforts appear to support that conclusion—we rather incline to the view that they have kept within the letter of the law. Again, the present Chicago authorities are simply suffering from the inane acts of their predecessors in office. At most, two gas companies could supply the present and future gas demands of Chicago, but owing to the inanity of the past the Chicagoese now have many companies to do the work of two. It looks to us as if the disputed charters will ultimately be found to be “quite binding.” [Since the above was written, the City Council, by a vote of 28 to 5, revoked the Equitable Company’s charter.]

THE FINAL WARNING.

This number of the JOURNAL contains Secretary Humphrey’s final note of warning to the members of the American Association, and in fact before its hints and promises have been conned by our far-Western readers the convention will be engaged in earnest work at Dockstader’s Hall. From the official notice it is learned that other gentlemen than those previously announced have promised to entertain the convention with papers, on subjects pregnant with interest to the fraternity. Indeed the list is quite promising, and its make up insures a plentitude of matter wherewith to keep the members busily engaged during the hours allotted to the strictly technical sittings of the Society. Although the local Committee of Arrangements, at the outset of its labors, encountered some difficulty in figuring out a plan for the satisfactory entertainment of the Association, it now remains to be said that those who are to profit (in a strictly pleasurable sense) by its work will subsequently agree with us that the Committee knew no such word as fail—“Cap.” White and the genial proprietor of the Oregon Iron Works are aware, however, that its expurgation from their vocabulary was only accomplished by dint of labor. It will also be noticed that the price of tickets to the banquet has been fixed at \$3 instead of \$5, as reported in the Secretary’s prior notice. We can but add that a large attendance is the only requisite needed to complete the Association’s measure of satisfaction. Hence let the clans assemble.

Oil and Water Gas as Illuminants.

Mr. Chas. F. Prichard, of Lynn, Mass., contributed the following specially prepared paper to the *American Manufacturer*:

The illuminating gas commonly spoken of as water gas is in reality a mixture composed of about two-thirds water gas and one-third oil gas, the former produced by the action of incandescent carbon on steam and the latter by the distillation of petroleum or its products. The illuminating power of a gas is due to certain compounds of hydrogen and carbon called heavy hydrocarbons, a small amount being sufficient to produce considerable illuminating power. For instance, in coal gas 6 per cent. of the mixture produces the illumination. Water gas is composed as follows:

Hydrogen	45
Marsh gas.....	2
Carbonic oxide.....	45
CO ² , N., O., &c., (impurities).....	8
	100

This evidently contains no illuminants and consequently has no illuminating power. The question, therefore, naturally arises why it has assumed such importance in illuminating gases if it has no illuminating power. Had it not been for the discovery of petroleum in such great quantities, its cheapness and the ready means of producing a large amount of these illuminants by its distillation, water gas would not have been known as an ingredient in illuminating gas, for the cost of adding illuminants from any other source than petroleum would have made the selling price prohibitory. Water gas is wasteful of illuminants, requiring double the amount needed by coal gas to produce the same candle-power. The ease and low cost of producing illuminants from oil

has, however, offset this disadvantage, and at present prices there is no difficulty in gas made from water gas competing with other gas, if the place of manufacture is not too far distant from the oil fields.

As petroleum became plenty processes, plans and patents for the production of an oil gas multiplied. Stripped of their various details, all are substantially the same and consist in subjecting the oil to a red heat. By almost any means of accomplishing this, 70 cubic feet of 70-candle-gas can be produced from a gallon of oil. This gas is composed of about 60 per cent. marsh gas and 40 per cent. hydrocarbons or illuminants; it is of high specific gravity and costly per cubic foot, but, as its illuminants indicate, of high candle-power.

This large percentage of illuminants makes it extremely difficult to secure complete combustion, and while the result of incomplete combustion in other gases may not be noticed, in oil gases it produces a disagreeable smoke and an extremely offensive smell, particularly if the oil is crude or if, perhaps, the distillation has not been perfect. More than this, its heaviness and the difficulty which each particle of carbon in the concentrated mass meets with in its endeavor to secure its complement of oxygen results in a slow, prolonged combustion, and the production of a yellowish light, not the desirable white light which the intense heat of a quick combustion would produce. Besides these, its heaviness, cost per cubic foot, concentration requiring small burners which clogged badly, and its difficulty of distribution soon demonstrated to both manufacturer and consumer that a lighter, more bulky gas was needed.

The most obvious remedy is to dilute the oil gas, and to dilute with air is the most natural suggestion. A gas containing about one-half air makes a fairly good gas for small towns and factories, but it is a heavy mixture, of sluggish flame, not suitable for open burners of low flame temperature, and the dilution cannot be carried far enough to enable the gas to compete with other gases. The desirable qualities of a diluent are such that it should be a combustible, of low specific gravity; that it should be generated cheaply and with rapidity, and that it should be of high flame temperature. Many gases have been tried, and in actual working to-day oil gas is combined with producer gas, mixed producer and water gas, wood gas, natural gas, the product of the “cracking-up” of natural gas and coal gas. Barring natural gas, which is of course not everywhere available, and coal gas, to which oil gas is added as an enricher, the choice of a diluent may be brought down to producer gas and water gas.

	Producer Gas.	Water Gas.
Hydrogen	6	45
Marsh gas.....	3	2
Carbonic oxide.....	23	45
Nitrogen	65	2
Other impurities.....	3	6
	100	100
Specific gravity.....	97	57

Bearing in mind the main requisites of the diluting gas, a glance at the composition of these two gases indicates at once which is the better. Being composed almost entirely of combustible gases, water gas is far superior to producer gas in this respect. Its superior lightness is shown by its specific gravity, and its higher flame temperature is indicated, without the necessity of calculation, by the small amount of non-combustibles as compared with the larger amount of heat absorbing nitrogen in the producer, while the necessity of distributing 65 per cent. of a gas which is positively detrimental is a serious obstacle to the use of producer gas, or indeed any gas containing large amounts of non-combustibles.

Any mixture of the two gases forming what is known as producer water gas would have the same objections in a lesser degree, but still powerful enough to more than compensate for the advantages of a continuous process, which producer gas or producer water gas would have.

In conclusion, it may be said that generally speaking water gas has been found by theory and practice to be the best diluent for oil gas, which accounts for its use in the manufacture of illuminating gas, but although water gas constitutes two-thirds of the mixture popularly called water-gas, and although it bears with the public its name, nevertheless it is of secondary consideration and its use is to dilute, to aid distribution, and by its heat to intensify, the illuminating value lying latent in a gallon of oil, and the gas which actually lights our houses is oil gas, when so-called water gas is used.

We beg leave to say that, by arrangement with the Goodwin Gas Stove and Meter Company, we are prepared to offer the “Directory of Gas Light Companies in the United States and Canada,” published by that house, at the price of \$3 per copy.

The Effect of Carbonic Acid upon the Illuminating Power of Coal Gas.

[An article, communicated to the *London Journal*, by Mr. Jno. T. Sheard, F.C.S., Chemist to the Salford Corporation Gas Department.]

That the presence of carbonic acid in coal gas is injurious to the illuminating power of the latter is a truth not only self-evident from theoretical considerations, but realized as an actual (sometimes a distressing) fact in the experience of most gas managers. It is therefore extremely valuable, as well as interesting, to know the nature and extent of such hurtful influence. Important, however, as is this matter to the manufacturer of gas, it would seem—judging from the paucity of information that is available on the subject, and the almost complete absence from the literature of gas making of any records of actual tests—to have received little attention at the hands of experimentalists. With the exception of a paper, by Mr. C. J. Russell Humphreys, of Lawrence, Mass., read before the American Guild of Gas Managers,* I have been unable to find that the subject has come (during the last 10 or 11 years at least) before any of the now numerous Associations of Gas Managers; while such mention of it as there is in the ordinary works of reference may be summed up in the somewhat vague statement that 1 per cent. of the impurity in question reduces the illuminating power of coal gas to the extent of from 6 to 8 or 10 per cent.

Mr. Humphreys' paper is interesting and valuable, so far as it goes; but it does not go far enough. It contains the results of a series of tests upon the illuminating power of gas containing carbonic acid, and corresponding tests upon the same gas after the removal of the impurity in a lime purifier. It deals with gas from which the carbonic acid had been partially removed, by means of lime, in the ordinary course of purification; while the amount of the impurity remaining in the gas appears to have been determined only on one occasion, although the tests extended over several days. And notwithstanding that the proportion of carbonic acid in gas produced from different coals, or under different conditions of distillation, varies very considerably, there is nothing to show that means were taken to insure that the gas tested was of precisely similar composition on every occasion. Further, the actual illuminating power of the gas is not stated; the difference observed between the two series of tests only being given. From all which it will be gathered that the paper in question, lacking (or, shall we say, omitting to mention?) such desirable particulars, and, moreover, essaying to deal only partially with the subject, does not supply the whole of the information that is wanting, but leaves room for further experiments and fuller investigations.

Before proceeding to detail the results of my own experiments, which have called forth this article, it may be advisable to restate, in brief summary, the results arrived at by Mr. Humphreys, as follows: An analysis of the gas operated upon (which, as already remarked, had undergone partial purification from carbonic acid in lime purifiers) showed that it contained 1.32 per cent., by volume, of carbonic acid (CO₂). When tested in the photometer, using a "D" Argand burner, the observed illuminating power (on an average of five tests) was 0.8 candle below that obtained in corresponding and immediately succeeding tests after the gas had been completely freed from its carbonic acid in a small purifier near to the photometer. Tested by various flat-flame burners, a difference (average of 7 tests) of 1.03 candles was found. The paper subsequently proceeds to discuss the relative cost of abstracting the 1.32 per cent. of carbonic acid, and of making up for the lost illuminating power by the use of more cannel. With this branch of the subject I am not, as regards the present article, concerned.

I had long purposed the carrying out of a somewhat similar series of experiments, designed to shed light upon this subject; and, as far as might be, to determine the extent to which the illuminating power of coal gas suffers from the presence of carbonic acid. Circumstances, however, prevented me, until quite recently, from accomplishing this purpose in the careful and complete manner I desired, and which the importance of the information to be obtained demanded. While I have followed, to some extent, Mr. Humphreys' lead, I have endeavored, by more numerous and varied experiments, to secure results which should be both more valuable in themselves and of wider service; and also to supply the deficiencies which, as above indicated, detract from his otherwise valuable experiments.

The gas produced at the Salford gas works is not purified from carbonic acid, the illuminating power being maintained by the means of cannel. The first requisite for the carrying out of the experiment was, therefore, at hand. But, in order that satisfactory results might be obtained, it seemed to me essential that the gas to be tested should be of the same quality and composition throughout—in so far at least as this could

be secured by the means at disposal. A supply of gas was required that might be depended upon to remain the same, in general composition, at the end as at the beginning of the experiments; so that the results should not be liable to vary by reason of differences in the proportion of carbonic acid on the one hand, or of illuminating power on the other. Accordingly, on Aug. 8, of the present year, a gasholder at one of the Salford gas stations, containing at the time about 90,000 cubic feet of gas, was shut off at both inlet and outlet, and connection made, by means of a 1-inch wrought iron tube, between its interior and the photometer. A small purifier, charged with well-moistened lime, was arranged close to the photometer, with bye-pass connections, so that the gas might proceed direct from the gasholder to the photometers, or be caused first to travel through the purifier. A second and smaller bye-pass was subsequently arranged, in order that, while passing the great bulk of the gas through the purifier, a small portion of the stream might be diverted and afterwards allowed to mix with that which had been purified. The object of this arrangement was to enable a gas containing a smaller proportion of carbonic acid than originally existed in that in the gasholder to be tested. By its means it became possible to vary artificially, so to speak, the composition of the gas passing to the photometers, and, by careful adjustment, to produce at will a mixture containing any required proportion of carbonic acid smaller than the original.

The tests commenced on the 10th of August, and continued, with occasional intervals, to the beginning of September. The first experiments were made upon the gas as it existed in the gasholder, and which contained, as will be seen, rather more than 2½ per cent., by volume, of carbonic acid. Simultaneous tests were made with the Bunsen photometer, Lowe's jet, and Sugg's illuminating power meter. In Mr. Humphreys' experiments the gas was consumed, in the Bunsen photometer, at the same rate when purified from carbonic acid as when unpurified. This, I maintain, is a faulty principle, as it is possible (and, indeed, very likely) thereby to do an injustice to the gas in one or other experiment, and it prevents the realization of that which it is especially intended to attain—viz., the consumption of the gas under the same conditions in both cases. The true principle (and that which I have adopted in these experiments) is to adjust the flame always to the height at which the gas is being burnt to the greatest advantage as regards the development of light; whereby equal justice is done to the purified and unpurified gas, and truly comparative results obtained. The observed illuminating power is in all cases corrected to the standard rate of 5 cubic feet per hour, and to the barometrical pressure of 30 inches, and temperature of 60 degrees F., so that the whole of the results hereinafter set forth are strictly comparative with each other. In the Bunsen photometer the gas was consumed through a burner similar to the one used by Mr. Humphreys—viz., a Sugg's "D" Argand, having 24 holes; and sperm candles were employed as the comparison standard. The light value of candles being notoriously variable, a different pair was employed for almost every test, as is indicated in the second column of the tables; and an average obtained from the result of ten experiments. For with candles as the standard, we cannot expect to get absolutely correct results; we can only hope, by means of averages, to approximate very nearly thereto. It must, however, be understood that in each complete experiment (consisting of a determination of the illuminating power of the gas before and after the removal of carbonic acid), the same candles were employed for the two operations. With each photometrical experiment, or group of immediately succeeding experiments upon the unpurified gas, a determination was made of the amount of carbonic acid it contained. This was effected with facility and accuracy by means of the improved method described by the writer in a recent issue of the *Journal* (*ante*, p. 240). Similar determinations were made, in some instances, on the gas after it had passed the lime purifiers; when it was found, as the result of several tests, that the amount of carbonic acid remaining in the gas was under 0.1 per cent.

Table I. contains the results of experiments with an Argand burner—the first half of the table showing the effect of 2.68 per cent. of carbonic acid (the full amount originally contained in the gas) in reducing the illuminating power; the second half showing the corresponding loss experienced when the gas contains only 1.06 per cent. of the impurity. In these results it will be noted, as of the first interest, that 2½ per cent. of carbonic acid causes a reduction of illuminating power of only 1½ candles, or less than 7 per cent. reckoned upon that of the purified gas; and 1 per cent. of the impurity, a reduction of only two-thirds of a candle, or 3 per cent. The latter result—a loss of 0.69 candle for 1.06 per cent. of carbonic acid—agrees very closely with the result obtained by Mr. Humphreys with the same burner—viz., 0.8 candle for 1.32 per cent. It differs, however, very much from the commonly received statement that 1 per cent. of carbonic acid reduces the illuminating power 6

*See Vol. XLII., p. 288.

cent. or more. Even supposing the latter statement to refer only to common coal gas of (say) 16-candle power, I doubt very much its truth. Doubtless the effect of carbonic acid is in inverse proportion to the illuminating power of the gas, or a given percentage of the impurity will exert a less depreciatory effect upon rich gas than upon poor; but I imagine that the actual loss of illuminating power due to carbonic acid is, within moderate limits, a constant quantity, no matter what the illuminating power. That is, speaking generally, I suppose that 2½ per cent., for instance, of the impurity will cause a loss of 1½ candles, and 1 per cent. a loss of two-thirds of a candle upon gas of 16-candle power, as well as upon gas of 23 candles. Even in that case, the 1 per cent. of carbonic acid would reduce the illuminating power only by some 4 (not 6) per cent. These observations, however, are put forward merely as a thoughtful surmise on the subject, as they are based upon no actual experience. It is to me somewhat remarkable, and a result which I should hardly have expected, that the destructive effect of carbonic acid is in nearly exact proportion to the quantity contained. Thus, 2.68 per cent. of the impurity causes a loss of 1.56 candles, and 1.06 per cent. a loss of 0.69 candle; or at the rate of 0.58 candle for each 1 per cent. in the former case and 0.65 candle in the latter. Whether this correspondence would be maintained with a higher percentage, is, I think, more than doubtful. Reason would teach that the proportional effect will diminish with each increment of carbonic acid; as, indeed, the figures show that it does, but to only a very small extent.

TABLE I.—Sugg's "D" Argand Burner.

Date.	Distinctive Mark of Candles Employed.	Carbonic Acid (CO ₂) in Gas. Percentage by Volume.	Illuminating Power of Gas.					
			Bunsen Photometer.			Mean of Lowe's Jet and Sugg's Illuminating Power Meter.		
			CO ₂ Present.	CO ₂ Absent.	Difference.	CO ₂ Present.	CO ₂ Absent.	Difference.
1887.			Candl's.	Candl's.	Candl's.	Candl's.	Candl's.	Cdles.
Aug. 10...	A	2.67	19.68	21.52	1.84	19.82	20.97	1.15
" 11...	B	2.64	20.88	21.89	1.01	20.38	21.46	1.08
" 15...	C	2.69	21.00	21.84	0.84	19.52	20.15	0.63
" 17...	C	2.60	21.78	24.64	2.86	20.52	21.60	1.08
" 18...	D	2.69	21.29	22.94	1.65	20.48	21.62	1.14
	E	2.69	21.80	23.38	1.58	20.61	21.62	1.01
	F	2.69	21.80	23.26	1.46	20.61	21.67	1.06
Aug. 24...	J	2.69	21.88	23.66	1.78	20.29	21.30	1.01
	K	2.69	23.30	24.73	1.43	20.29	21.30	1.01
Aug. 26...	L	2.72	22.57	23.74	1.17	20.78	21.70	0.92
Average...	2.68	21.60	23.16	1.56	20.33	21.34	1.01
Aug. 19...	D	1.10	21.84	23.08	1.24	21.40	21.66	0.26
	E	1.10	22.16	22.73	0.57	21.40	21.66	0.26
	F	1.10	22.28	22.72	0.44	21.40	21.66	0.26
Aug. 20...	G	1.17	22.10	22.78	0.68	21.00	21.37	0.37
" 22...	H	1.01	22.63	23.39	0.76	21.04	21.30	0.26
	I	1.01	22.95	23.16	0.21	21.04	21.30	0.26
	I	1.01	21.39	22.40	1.01	21.16	21.41	0.25
Aug. 23...	D	0.99	20.92	21.68	0.76	20.70	20.96	0.26
" 26...	L	1.06	22.32	23.21	0.89	21.56	21.88	0.32
	M	1.06	22.46	22.82	0.36	21.56	21.88	0.32
Average...	1.06	22.11	22.80	0.69	21.23	21.51	0.28

Specific Gravity of the Gas (Air = 1,000).

	CO ₂ Present.	CO ₂ Absent.
August 10.....	527	500
" 11.....	516	503
" 15.....	500	495
" 17.....	518	492
" 18 (three tests).....	516	493
Average.....	516	496

The other most noticeable feature of the results exhibited in Table I. is the much smaller extent to which the indications of the inferential photometers are affected by carbonic acid than are those of the Bunsen. Thus, while 2½ per cent. of the impurity causes a loss of 1½ candles according to the Bunsen photometer, by the inferential photometers a difference of only 1 candle is experienced. Similarly, 1 per cent. of carbonic acid causes a loss of 0.69 candle by the former, and only 0.28 candle by the latter. This result was not altogether unexpected. It was but reasonable to suppose that, as the Bunsen photometer took cognizance both of intensity and quantity of light, while the inferential

photometers recognized only the latter, the sum total of the effect of carbonic acid (which diminishes the heat intensity as well as dilutes the flame) would be greater upon the indications of the Bunsen than on those of the inferential photometer. In an article on "Experimental Investigations on Photometry," contributed to the *Journal* a year ago, the present writer, referring to this subject and reasoning from theoretical considerations, stated: "The general conclusion to be drawn * * is that coal gas containing nitrogen or carbonic acid will give higher results, as regards illuminating power, when tested in the inferential photometer, than when tested in the Bunsen; and, of the two, carbonic acid having the higher specific heat will exert the greater effect."

Having determined the effect of carbonic acid upon the illuminating power of gas when consumed in an Argand burner, it remained to do as much for burners of the flat-flame type. In order to obtain extreme yet truly representative results, two burners, each the cheapest and simplest of its class, but of widely dissimilar construction, were employed—viz., Bray's No. 3 regulator union jet, and Sugg's No. 3 steatite flat-flame. The same principle was followed in the adjustment of the rate of gas consumption with these burners as with the Argand—that, namely, of burning the particular amount of gas which could be most effectively consumed. This condition is satisfied, in the case of flat-flame burners, when the flame is just upon the point of flagging; or, with the particular burners mentioned, sufficiently near for practical purposes when the horns which form, with an excessive pressure, at the sides of the flame just disappear. The results thus obtained are contained in Table II., which is thus strictly comparative, as regards flat-flame burners, with Table I.

TABLE II.—Flat-Flame Burners. Sugg's Steatite Flat-Flame Burner, No. 2.

Date.	Distinctive Mark of Candles Employed.	Carbonic Acid (CO ₂) in Gas. Percentage by Volume.	Illuminating Power of Gas.					
			Bunsen Photometer.			Mean of Lowe's Jet and Sugg's Illuminating Power Meter.		
			CO ₂ Present.	CO ₂ Absent.	Difference.	CO ₂ Present.	CO ₂ Absent.	Difference.
1887.			Candl's.	Candl's.	Candl's.	Candl's.	Candl's.	Cdles.
Aug. 30...	M	2.65	15.74	18.09	2.35	20.09	21.18	1.09
	N	2.65	16.13	19.29	3.16	20.09	21.18	1.09
	O	2.65	16.09	19.02	2.93	20.09	21.18	1.09
	P	2.65	16.78	19.22	2.44	20.09	21.18	1.09
Sept. 1....	S	2.63	17.86	19.95	2.09	20.10	21.14	1.04
Average...	2.65	16.52	19.11	2.59	20.09	21.17	1.08

Bray's Regulator Union-Jet Burner, No. 3.

Aug. 31...	N	2.58	8.72	11.68	2.96	20.20	21.27	1.07
	O	2.58	8.74	11.17	2.43	20.20	21.27	1.07
	P	2.58	8.72	11.34	2.62	20.20	21.27	1.07
Sept. 1....	Q	2.63	8.63	11.31	2.68	20.13	21.17	1.04
	R	2.63	8.32	10.66	2.34	20.13	21.17	1.04
Average...	2.60	8.62	11.23	2.61	20.17	21.23	1.06
Gener'l } Average }	2.62	12.57	15.17	2.60	20.13	21.20	1.07

Sugg's Steatite Flat-Flame Burner, No. 3.

Sept. 7....	N	1.06	18.77	19.65	0.88	20.72	21.10	0.38
	S	1.06	18.78	19.71	0.93	20.72	21.10	0.38
Sept. 8....	T	1.04	18.32	19.48	1.16	20.62	21.05	0.43
	W	1.04	18.70	20.40	1.70	20.62	21.08	0.46
	X	1.04	18.21	19.23	1.02	20.66	21.05	0.39
Average...	1.05	18.56	19.70	1.14	20.67	21.08	0.41

Bray's Regulator Union-Jet Burner, No. 3.

Sept. 3....	Q	1.18	10.07	11.06	0.99	20.52	20.90	0.38
	R	1.18	9.26	10.44	1.18	20.52	20.90	0.38
Sept. 6....	T	1.13	11.78	12.84	1.06	21.25	21.68	0.43
	U	1.10	11.76	12.42	0.66	21.25	21.68	0.43
	V	1.10	11.58	13.30	1.72	21.25	21.68	0.43
Average...	1.14	10.89	12.01	1.12	20.96	21.37	0.41
Gener'l } Average }	1.09	14.72	15.85	1.13	20.81	21.22	0.41

A glance at the results exhibited in the second table will show that, while the observed illuminating power is in all cases much less, the difference between the illuminating power of the gas containing carbonic acid and of that from which the impurity had been removed is much greater than in Table I. Had not Mr. Humphreys' experiments shown that carbonic acid exerts a greater effect upon the illuminating power of flat-flames than of the other class, such a result might have been anticipated from theoretical considerations. The effect of carbonic acid in a flame is twofold. In the first place it dilutes the combustible gas with an inert substance; in the second, it refrigerates or cools the flame. The former action is common to, and equal in the flames of both the Argand and flat-flame burners. But it will be obvious that the cooling action of the impurity will exert a greater effect upon the flame which is the brighter or more intense—viz., the flat-flame—than upon the other; because it is notorious that the illuminating power of a flame increases in a much greater ratio than the heat intensity. Thus it comes about that 2.62 per cent. of carbonic acid causes, with flat-flame burners, a loss of illuminating power equal to 2.60 candles, and 1.09 per cent. a loss of 1.13 candles; being 67 and 64 per cent. respectively more than with the Argand burner. Calculated upon the illuminating power developed in each case, the loss is very much greater; being 17 and 7 per cent. respectively with the flat-flame burners, as against 7 and 3 per cent. with the Argand. It is a most noteworthy circumstance that, while the two flat-flame burners employed developed from the gas widely differing proportions of the total illuminating power, the actual loss of light, through the presence of carbonic acid, was practically the same. Consequently the loss, represented in terms of the amount of light developed in each case, is much the greater on the less economical burner. Thus, 1 per cent. of carbonic acid is responsible for a loss of 9 per cent. of illuminating power with the union-jet, and of only 6 per cent. with the other burner. It seems, therefore, that it is all a question of burner whether the percentage effect shall be high or low; and the very divergent statements on this head, which have hitherto constituted the only available information, are now explained. There is also observed in the results obtained with flat-flame burners what was likewise noted in the case of the Argand—that the percentage effect of the impurity in destroying the illuminating power is practically the same with the large as with the small amount.

In conclusion, let me endeavor briefly to summarize the results that have been established through this investigation. These are that 2½ per cent. of carbome acid (the full amount originally contained in the gas under examination) destroyed the illuminating power of 23-candle gas to the extent of 1½ candles when the gas was burnt in an Argand burner, and of rather less than 2½ candles when flat-flame burners were employed; that 1 per cent. caused a similar loss of two-thirds of a candle with an Argand, and of rather more than 1 candle with flat-flame burners; that the actual loss of illuminating power, when flat-flame burners are employed, is practically the same, with an equal amount of impurity, whether the illuminating power developed be high or low; but, as an inseparable corollary, that the percentage loss of light increases as the "duty" of the burner decreases; and that the effect of carbonic acid in destroying the illuminating power of coal gas increases, *ceteris paribus*, in nearly equal proportion with the amount of the impurity contained.

Petroleum in Russia.

In the course of a report made to the United States Government by Jas. A. Chambers, now acting as the Consular Agent of this country at the port of Batoum, Asiatic Russia, the compiler says:

The great petroleum producing district is about 8 miles northeast of Baku, and is called Balakhani, taking the name of the Tartar village near it. Different parts of the district are known by other names, such as Sabunchi on the south, the Garden on the east, and Shaitan Bazar in the center; and local statisticians have again subdivided the fields into groups, of which there are 17 in the Balakhani district and 1 at Surakhani, about 5 miles southeast of the main district. At Surakhani there have been twenty-three wells drilled, the last one I think about the year 1879, but I find no estimate for the production of these wells, and I understand that they have produced little or no oil for several years. There is also a large refinery at Surakhani, which is supplied with crude oil by pipe-line from Balakhani.

Between 2 and 3 miles south of Baku, on the seashore, is another producing district, the area of which, as at present divided, is very small, called Bibi-Eibat. Twenty-two wells have been drilled here, and 14 of them were producing in July, 1886. In September one of those wells was drilled deeper, resulting in a large flow of oil. The production of

this well, it was claimed, was from 30,000 to 40,000 barrels (42 gallons each) per day for 15 days, after which it ceased to flow entirely. This well was less than 700 feet deep, but it was the deepest well in the Bibi-Eibat district, and had been producing from a shallower depth for two years. There is also a large and very modern refinery at this place.

The depth of the wells varies from 175 to 1,030 ft., there being only one well of the latter depth, and I am not positive that it is producing profitably. The average depth of the wells is steadily increasing, and is now said to be 500 ft. as against 350 ft. in 1882. The average depth of new wells is, however, more than 500 ft. I think it is over 600 ft. By many it is claimed that the increasing depth of the drilling is proof positive of the exhaustion of the territory, and that the depth of the drilling increases 50 ft. for every 500,000,000 gallons of crude taken out, but I have seen no calculations as to the depth of the lower strata of oil. Others claim that both the yield and the quality of the crude improves with deeper drilling, and that the territory will continue to produce from much greater depths. From my own observation, I am inclined to believe that the quality of the crude as an illuminant improves as the drilling gets deeper, but as to the increase in the product I am not informed.

Even here in Russia there is a great difference of opinion as to the relative merits of Russian and American illuminating oil, and while it is not generally asserted that the Russian refined can be made as good an illuminant as the American, there is no doubt that it can be and is made to burn quite good enough for all purposes, and emits no disagreeable odor while burning.

After taking from Russian crude oil say 30 per cent. illuminating distillate, about 15 per cent. is taken from the residuum, which is called "solar oil," and which, although a nice-looking white oil, is too high fire-test to burn in ordinary lamps, and not sufficiently good for lubricating purposes. This is generally mixed with the "astatki" or crude residuum, although the last Baku congress of petroleum people "*Resolved* that its use should be made compulsory for the purpose of lighting public buildings, theatres, circuses, hotels, etc., that the use of kerosene, (refined) should be prohibited in such buildings, and that the ordinary restrictions applied to mineral oils, in transportation, storage, etc., should be taken off solar oil, and it placed in the same category with vegetable oils." This is, however, only a petroleum producers' resolution, which will be understood, no doubt, in America. After the solar oil is taken, the lubricating oil distillate is taken off, and varies from 20 per cent. to 25 per cent. From this distillate a very good lubricant is made, as it is affected neither by intense heat nor great cold. The lubricating oil is made in Baku, but great quantities of the distillate are also shipped to England, France, Belgium and Germany, and there purified and made into lubricating oils. After the foregoing proportions are taken from the crude, the residuum, down to about fifteen per cent. of the whole, is taken off, and generally mixed with the solar oil. This is called "astatki" or crude residuum, and is the fuel of southeastern Russia. As the Caspian and Volga steamers, many of the railroads in eastern Russia, and the Transcaucasian Railroad use it for fuel, there is a great demand for it, and it sells at an average price of 0.1 cent per gallon on board cars or steamers at Baku. The 15 per cent. left in the still is called "mazoot," and, as it will not burn, is a total waste. A few years ago it was used in limited quantities to sprinkle the streets of Baku, which was a very good idea from a sanitary point of view.

Estimated as above, the yield of Russian crude in merchantable products is about 85 per cent., as follows:

	Per cent.
Illuminating oil.....	30
Lubricating oil.....	20
Solar oil.....	} 35
Astatki (crude residuum) }	
Waste.....	15
Total.....	100

Iron tanks for crude oil are but seldom used, as is also iron pipe for conducting the crude from wells to reservoirs. Instead of iron pipe, wooden box-troughs or dirt ditches are used for the latter purpose, and reservoirs are made by excavating the ground in the vicinity of the well, or by simply throwing up walls with the sand that has been thrown out of the wells. Of course there is a loss from the ground absorbing the crude, but the price is so low that this loss is insignificant. From the reservoirs the crude is pumped through pipes to the refineries, which are located on the seashore, about two miles east of Baku, at Chornai-Gorod (Black Town).

The specific gravity of Balakhani crude oil varies, but not sufficiently to make any difference in its value, so that it is all run together, forming a crude of about 0.865 specific gravity, or 32° Beaume. It contains no

paraffine, and very little benzine is made from it, none of which is lighter than 0.700 specific gravity. As I have said before, I think it exceedingly probable that the crude will be of a less specific gravity as the drilling deepens, as I find the oil from Nobels' No. 32 about 0.850 specific or $34\frac{1}{2}^{\circ}$ Beaume.

The distance from the wells to refineries is about 8 miles, and as the average elevation of the wells above the Caspian Sea is 175 ft., the piping of the crude is not at all difficult. There are now 14 pipe-lines, from 3 to 6 in. in diameter, and belonging to 13 different owners. The pumps used are either of American manufacture or made in England or Russia from American patterns, with the knowledge and consent of the American manufacturers and patentees. The latter, I am informed by men of experience with both kinds, are by no means as good as those made in America, and I have heard surprise expressed at the American manufacturers allowing their machinery to be so indifferently constructed in England and Russia.

The aggregate daily capacity of the 14 pipe-lines is about 100,000 barrels. The nominal pipeage charge is 1 kopeck per pood (about 4 cents per barrel), but the pipe-lines are generally owned in connection with both wells and refineries.

The great market for Russian petroleum is of course Russia itself, where it is protected from American competition by a prohibitory tariff. The Russian markets are reached principally by water transportation, *via* Caspian Sea and Volga River, to the eastern termini of the Russian railroads, and thence by railroad. Barrels were formerly used for the transportation; several barrel factories were erected at Baku and one at Tsaritzin on the Volga. The machinery in these factories is principally of German manufacture, and when made was probably as good as any in America. Now, however, it is not up to the American machinery for the same purpose. Labor was, however, cheaper than steam, and the steam-barrel works were a failure. Timber for barrels was always expensive, and the increased demand which came with the increased production made some other method of transportation absolutely necessary, and the result was the construction, for Nobel Bros., in Sweden, of a steamer to carry petroleum in bulk, which proved a great success, and completely did away with the use of barrels in the Baku trade. The Nobels have 13 of these steamers in service, carrying from 4,000 to 6,000 barrels each, all of which were constructed in Sweden and brought from the Baltic Sea *via* canal to the Volga River. The short locks in the canal necessitated the steamers being constructed so as to be taken through in two pieces and again joined together when the Volga is reached. This method of getting the steamers to the Caspian is of course very tedious and expensive, notwithstanding which there is now a large fleet of them in service.

The petroleum products are carried in these bulk steamers to a point at the mouth of the Volga River called "Davit Foot" (meaning 9 ft. of water), about 400 miles north of Baku and 90 miles from Astrakhan, where they are transferred into barges which are towed by small steam tug-boats to the various distributing points on the Volga, where tanks have been constructed for their reception and arrangements made for railroad shipments. The chief distributing point upon the Volga is Tsaritzin, about 350 miles from Astrakhan, but there is also tankage at Saratof, Kazan and Nijni Novgorod. From these points it is distributed all over Russia in tank-cars. Some is also exported to Germany *via* Riga and Libau (by sea), Eidtkunen by railroad and to Austria *via* Warsaw and Brody and Pod Volochisk. Owing to the gauge of the Russian railroad system being 5 ft., while that of the continental railroad system is the standard gauge, another transfer of the oil must be made at Eidtkunen for Germany, and at Warsaw, Brody and Pod Volochisk for Austria.

The number of tank cars in service upon Russian railroads north of the Caucasus is 2,500, or was a few months ago, as the number is constantly being increased. The tank-car is of the same style as the modern American tanks, but of uniform size and capacity, holding, nominally, 600 poods, although usually taking 660 poods or about 3,300 gallons.

Previous to the year 1883 all petroleum products were shipped from Baku by water. In that year the completion of the Transcaucasian Railroad provided another outlet to the Black Sea. Two ports on the Black Sea, Poti and Batoum, were available for the export trade, but Batoum was selected by this trade because of the superiority of its harbor and the advantage of its being a free port. The railroad company provided tank-cars to the number of 475 in 1883, and iron tanks were erected at Batoum. A can and case manufactory, with a capacity of about 7,000 cans 3,500 cases per day was erected by a large refiner of and dealer in Russian oil, the machinery necessary, together with the workmen to put it in running order, coming from America. Others also started to manufacture cans and cases by hand, and the business in-

creased so rapidly that in 1884 and 1885 the railroad company added 750 more tank-cars to its rolling stock.

The railroad from Batoum to Baku is 560 miles long, and is an exceedingly expensive road to operate, owing to the heavy grades in crossing the mountains. The highest point upon the road is the Suram Pass, about 135 miles east of Batoum, which is over 3,000 ft. above the level of the Black Sea. Upon the west side of the mountain the average grade for $3\frac{1}{2}$ miles is 185 ft. to the mile, and $1\frac{1}{2}$ miles of it is 238 ft. to the mile. Upon the east side of the mountain there is a grade of 253 ft. to the mile, but the greatest grade shown by the official statistics is 238 ft. to the mile for nearly 2 miles, while the average grade for 6 miles is 210 ft. to the mile. Work will soon be commenced upon a tunnel, or rather two tunnels, a long and short one, through the mountain at Suram, which when completed will materially lessen the grade. The long tunnel will be almost 3 miles, and, as the contour of the road will have to be changed materially for 10 to 12 miles, it is estimated that the work will require about 4 years for its completion. There is some talk about the railroad capacity being temporarily increased next year by double-tracking the road over the pass, but this would also require a great deal of time and money, and I have been reliably informed that nothing of the kind is contemplated by the company. The railroad company is steadily adding new tank-cars to its rolling stock (in January 500 more tank-cars besides 350 put in service by two large refining firms.) How much these additions to the tank-car service will increase the petroleum carrying capacity of the railroad I am unable to say. It requires about 1 hour and 25 minutes for a passenger-train to cross the Suram Pass, a distance of 10 miles, and for a freight-train nearly 2 hours; and with a constantly increasing general freight business it would not seem that the petroleum carrying capacity could be increased materially. The price charged by the railroad for transporting oil from Baku to Batoum is, at present rate of exchange, about 1.4 cents per gallon, and the yard charges, etc., at Batoum will increase the price to about $1\frac{1}{2}$ cents per gallon.

There are now in the oil business from Batoum 10 tank-steamers, with an aggregate yearly capacity, to the ports for which they are usually chartered, of from 75,000,000 to 80,000,000 gallons; and two or three more are reported due soon, while the carrying capacity of the railroad at present is not estimated at more than 70,000,000 gallons yearly. Thus it would seem that the gratuitous (?) puffing which the Russian petroleum business has lately had in the European press, with the very plain object of sending much needed capital to its assistance, has been only doubtfully successful, inasmuch as it has resulted in sending to the assistance of the trade, not money, but ships in such numbers as to advance the price of oil their charterers are compelled to buy, in order to keep them employed, to such a figure as to make the loss from the sale of it in European markets so great as to startle even the Russian exporter, who has heretofore exhibited such a courageous disregard of financial results. The situation must undoubtedly improve; because, at present prices for Russian refined at Batoum, profitable competition with American oil at present prices at New York is impossible, even in the Levant. Some of the many steamers chartered for the trade will be compelled to remain idle at the expense of the charterer, and of course all the charterers of these vessels feel very sure that they will not suffer in this manner, but that their competitors here must, and thus allow them to continue to export at no loss, and perhaps (with an advance in prices in America) at a profit.

The lesson the Batoum trade is now learning is undoubtedly an expensive one, and may impress upon it the fact that the price of refined at Batoum, and consequently the business of exporting, is wholly dependent upon the capacity of the railroad for carrying oil from Baku to Batoum, a material increase of which seems further away than ever, since it is currently reported and believed in Tiflis that the project of tunneling the Suram Pass has been pronounced impracticable (impossible is the word used) and abandoned by the engineers who had charge of the preliminary work. Some private tank-cars will be added to the rolling stock of the railroad in the spring, but the conditions upon which these cars are accepted by the railroad company, viz., that they can only be taken over the Suram Pass after all the cars belonging to the company are out of the way, seem to indicate a doubt in the minds of the railroad officials as to their ability to handle any more cars than are now in service.

The project of constructing a pipe line from Baku to Batoum, after having been definitely decided by a notorious English romancer, who published his specifications for the line in an English journal several months ago, was finally considered by a joint council of the ministries of Finance and State Domain, in St. Petersburg, January 12 (24 new style), and a conclusion arrived at against the construction of a line by

the Government, but ostensibly favorable to the granting of a concession for the construction of a line (for crude only, and subject to strict Government control) under certain conditions, 16 in number. I have had a translation made of these conditions, and while it would no doubt prove of great interest to American readers, in showing them the remarkable ideas held by Russian pipe line experts, I do not give it because the one clause viz., "No. 10. The company must prepare all necessary pipes and reservoirs at Russian works and of Russian material," precludes any possibility of American competition for furnishing material for it, and consequently the other conditions are of no importance to Americans. I will merely say that of the 16 conditions, there are 8, any one of which would, I believe, prevent any one with even the slightest practical knowledge of the pipe-line business from accepting this concession.

Electric Lighting from Central Stations.

Prof. Geo. Forbes, M.A., F.R.S., in addressing the members of the British Association on the above-named topic, remarked that, five years ago, disastrous speculation in purchasing and licensing patents at exorbitant rates paralyzed the financial community with regard to the public supply of electric light. A panic among gas shareholders in the House of Commons and elsewhere created, by Act of Parliament, obstacles to the industry. At the same time, crude and impossible schemes for distributing electricity, made out by incompetent persons, were tried and found wanting. The mistrust then engendered is now wholly unwarranted, and the common sense of the country must be re-awakened if this nation is to take any lead in the future applications of electricity to industry and the arts. Municipal authorities, capitalists, and members of Parliament seem to be in ignorance of the completeness of the systems now at the disposal of the electrical engineer, and of the enormous experience which we have gained by studying what has been done abroad. I hope to be able to explain away these doubts to some extent by a simple statement of the methods now generally adopted.

Having described the apparatus by which the electric light is produced, Prof. Forbes went on to say:

When I was asked to choose a subject on which to lecture to you, I felt that I should best be discharging my duty if I chose that branch of practical and applied science to which I have devoted the most attention. This subject is the means of distributing electric current to a large district from a central station. In this case a thin wire does not suffice to carry the large current required for all the lamps. Such a wire would get very hot, and more steam power might be used in heating the main conductors than in causing the lamp to shine. It is easy to calculate what size of conductor would be the most economical. I have here two great rods, each a foot in diameter, and this is the size required to supply a district with 100,000 lamps in the most economical way if the conductors were made of the best material, which is pure copper. You can see at a glance that the cost of some miles of such conductors would be prohibitive. The great difficulty of an engineering character which was encountered in the early attempts to introduce central-station electric lighting lay in the enormous cost of the copper conductors required to carry the current. This, as much as the electric lighting act of 1882, was the cause of the abandonment of all the earlier schemes. If we do not lay down thick conductors we suffer in two ways. First, the electric pressure is used up in the mains to such an extent that different consumers along the route of the mains do not get the same electric pressure, and the pressure at each house varies with the amount of light being used in other houses. Secondly, there is a great loss of energy in forcing the current through the thin mains. By thickening the mains we increase our capital expenditure, but we reduce the annual waste of energy in the mains, and it is easy for the engineer to determine the most economical arrangement. On doing this it was found that the cost was prohibitory for supplying large districts.

Deeply interested as engineers were in the progress of electric lighting, no engineer of eminence supported these early and crude schemes. The plan originally proposed was to lay positive and negative mains all over the streets, and to connect the lamps, singly or in groups, to these mains by wires. This can only be done economically in small establishments where the greatest distance of a lamp from the machine along the route of the conductors is little more than 200 yards. It is excellent for clubs, hotels, and country houses. If we connect each pair of our lamps in series, so that the same current passes through both, the electric pressure must be doubled, but the current is halved; and at once we have a reduction in the size required for the mains. The disadvantage of this is that if one of the lamps of a pair goes out, or is put out, the other lamp of the pair also goes out, as you see when I try the experiment. Here

are 12 lamps arranged in 6 pairs, and when I extinguish one of a pair the other goes out. Now, if I connect together by another wire all the wires connecting the pairs, you will see that when I extinguish one lamp there is still a course open for the current, and no other lamp goes out. But you do notice that the three top lamps are fed by the same amount of current as the six bottom ones, and are so much brighter. This is a serious disadvantage, but can be remedied by leading the middle connecting wire, which I just now introduced, to the middle of the battery or other source of electric energy which I am using. Now you see there is no difference in the brightness of the light, however many I may extinguish. This way of using three wires introduces a considerable economy in conductors, and extends the distance to which we can work economically to a quarter of a mile, as has been found from numerous trials, especially in America. This is generally called the three-wire system.

This, however, still leaves us a long distance from central-station lighting on a large scale. The idea of using high electric pressure in the mains commends itself because it cheapens our conductors. We have doubled our pressure by using the three-wire system. Can we advance farther in the same direction? If we use 2,000 volts pressure instead of 100 volts (the ordinary pressure of a glow lamp), we reduce the copper in our conductors about twenty-fold. But it is impossible to permit 2,000 volts pressure in houses where people might get shocks and be killed. It has been proposed to charge 1,000 cells of a secondary battery in series from a central station, and discharge them to a small district 50 cells in series. This would involve a storehouse for every quarter of a square mile, or even less. The system would be very good were it not for the expense of secondary or storage batteries. This puts the matter at present out of the question. It may come in time. It has the enormous advantage of leaving the system in working order even when machinery gives way, and of storing up an unusual amount of energy for special occasions, such as a general illumination. At present there is only one system thoroughly worked out for using high pressure in the mains and low pressure in the lamps. It is founded upon Faraday's discovery of induction. When I send an electric current through a coil of wire which has an iron core, the latter becomes a magnet, and continues to be one so long as the current is continued. During the act of magnetizing, a certain amount of work is done, and is stored up in the magnet. At the moment when the current ceases this energy is restored by the magnet in the form of additional current. Here I have an electromagnet with two iron limbs separately wound. The wire of one limb can be connected with an incandescent lamp; that of the other with a battery. I now pass a current through the wire on one limb. Next I connect a glow lamp with the wire of the other limb. I now break the electric circuit, and you see that the glow lamp in the second circuit glows for a moment. The energy stored in the magnet is given up to the glow lamp. An induction coil consists of an iron core surrounded by two coils, one of thick wire, the other some miles long, but of very thin wire. It also has a means for rapidly interrupting the electric current from a battery in the short thick coil. This magnetizes and demagnetizes the iron core. The iron core gives off energy to the long thin coil, and an intermittent current of very high pressure is set up in that wire. You see that long sparks flash through the air from one end of the wire to the other. I now pass the current thus obtained through a resistance equivalent to many miles of telegraph wire, and send it through the thin coils of induction apparatus at the other end of the room. This magnetizes and demagnetizes the iron core, and if I connect the thick coils of the distant apparatus with glow lamps, you see them shine brightly. Here we have a high-pressure current which can be sent over a distance of many miles through a thin wire, and then converted into the ordinary low pressure required for lighting purposes. The system, to be perfect, must be worked by a dynamo machine which gives a high-pressure current of electricity alternating in direction. The first person to use such an alternating current of high tension in the mains, and to convert it by means of efficient apparatus into a current of the ordinary pressure required for the lamps in a house, was M. Gaulard. It is now being largely used, both in Europe and America. An engineer has the greater confidence in recommending this system, because, if ever storage batteries become available, the same system of conductors will do, and no change need be made.

I must now say a word about the main conductors. These may be laid either overhead or underground. The former plan has most generally been adopted in England and America. In America because the prime cost is less; in England because the electric lighting act imposes prohibitive conditions on underground conductors, but does not deal with overhead ones. For a permanent works there is no doubt that underground conductors are the best, and also the cheapest in the end if

the contractors are not mulcted for the concession. It has been said that no good system of underground conductors exists. This is sheer nonsense. The plan I will explain is not by any means the only one, but I believe it to be the cheapest and perhaps the most complete. It has also the merit, as a system to describe, of novelty.

Gas pipes are laid down in the ordinary way to serve as a trough for the conductors. Gas pipes are used because sixty years' experience has taught us what they will do, and made our workmen acquainted with them; and they cost little. Two porcelain discs in each pipe serve as insulators. They are pierced with three holes (say an inch diameter) for the three-wire system, and with more or less holes in other systems, according to requirements. Through these holes are passed thin split copper tubes, which by springing out grip the porcelain insulators. Into the ends of these the ends of additional lengths of split tubing are squeezed. Thus we get a long length of gas piping, with two or three or more insulated copper tubes. These copper tubes are not the conductors, but serve other purposes. Manholes with sumps are provided at every cross street. Naked wire is drawn through the copper tubes, only as much copper wire being used as suffices for immediate wants. Additional wire can be added as consumers are added to the district. When a house is to be joined to any part of the mains, a hole is tapped in the gas pipe and wires soldered on to the copper tubes, and inclosed in a small iron gas tube screwed into the main pipe. The number of wires can at any time be added to or diminished. When the tube is two-thirds full it is difficult to pull more wire through. The old wires may then be removed and a bare cable of wire filling the whole tube drawn through. I believe that in speaking to practical working men, as I am just now, I am addressing those who can appreciate the benefits of this system, which I have not time to dwell on more fully at present. It will be described in Section G of the British Association in a few days.

In conclusion, let me say a few words on the progress of central-station electric lighting. In this country it has been slow, owing largely to the electric lighting act of 1882. If electricity be put on the same terms as gas, and if you have your station on a river bank or any place where coal and water are cheap, you can be well supplied with electric light at the same price as gas at 3s. per thousand cubic feet, with a fair profit to the undertakers. On the continent of Europe there are numerous central stations, mostly small, some supplying 30,000 lights. In America the progress has been enormous. Arc lights in series are used largely for street lighting and for shops, and central stations for glow lamps have been plentifully started on the parallel, three-wire, and induction systems. Most of the best companies concerned pay good dividends. The total money invested in electric lighting in the United States is estimated this year to amount to £30,000,000. In 1886 there were 58 Edison central stations supplying 149,000 lamps, besides 181,463 lamps in isolated plants. The Westinghouse Company has during this year been setting up central stations at the rate of 12,000 lamps per month. It is estimated that in 1885 the Brush Company alone had 96,000 arc lamps in use in the States, the number having doubled in each year from 1881. At present there are probably 300,000 arc lamps in use in that country. The Americans are also getting the start of us in electric railways. We once beat the whole world in steam railways. Our pre-eminence in steam has gone far to make this country what it is. So let it be with electricity, for we are now passing into the age of electricity.

A Handy Machine for Piercing Gas Pipes.

The recent English jubilee rejoicings were, among other things, notable for the large quantities of gas consumed in the various illuminating devices that were employed in almost every town or village that could boast of a gas works.

The Messrs. Winn & Co., of Birmingham, appreciating the fact that there would be a good demand for a handy and reliable instrument for piercing or perforating the pipes composing the illuminating devices, accordingly introduced a machine, the type of which is illustrated in the accompanying cut.

The *Engineer*, in calling attention to the Winn apparatus, says of it: "It is not only a labor-saving, but, what is more important in these matters, a time-saving contrivance. Moreover, the holes made by it are regular in size, and are all pierced straight and true."

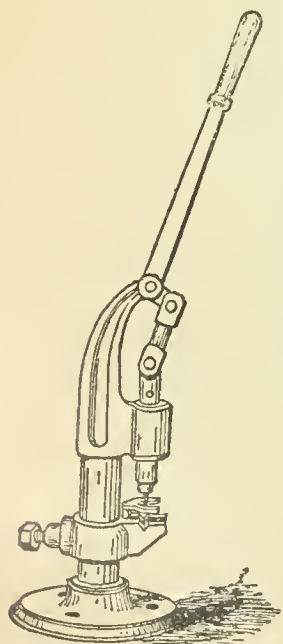

The Winn Device for Piercing Gas Pipes.

On the Determination of Hydrous and Anhydrous Peroxide of Iron in Irish Bog Oxide of Iron.

Jas. Sutherland, F.I.C., in an article contributed to the *Gas and Water Review*, remarks that a few months ago he read with special interest the case of the Swansea Gas Company v. Abbott and Company, which took place before Justice Stephen and a special jury, in the High Court of Justice, Queen's Bench Division, London, and was much struck with the nature of the evidence given by the various chemists and engineers on both sides. Mr. Sutherland then continues:

Dr. Morgan, of Swansea, stated that he never met with anhydrous peroxide in bog oxide, and Mr. C. Heisch, F.C.S., F.I.C., stated there was no way of telling, by means of analyses, what amount of oxide was hydrated; and again Mr. Bernard Dyer, F.C.S., F.I.C., stated that he was not aware of any mode by which a rigid line might be drawn between the hydrated and anhydrated oxides.

Now, in our bog oxide deposits the ore exists, both in an anhydrated and hydrated condition, the anhydrous oxide being invariably hard and metallic, resembling slag or melted dross, whilst the hydrated exists when taken from the deposits as a grey, unctuous, soft clay. The depth of the deposits vary, say two to six feet thick, with a superstratum of bog or peat. Where this superstratum exists to a great depth, as it is frequently the case, it has not been found economical to work the oxide.

As is stated, the oxide (which is really a protoxide) exists as a soft, grey clay, and is easily worked—in fact, the natives handle the oxide in exactly the same manner as they do their peat. It is thrown to the surface by peat spades, and spread on the bog, being frequently turned over, so as to expose it to the atmosphere, and thereby in a few months it becomes peroxidised, changing to a light, flocculent brown.

The anhydrous oxide has rarely any covering, and is frequently associated with boulders and overlying basalt, although it is not uncommon to find it existing in a thin stratum underneath the grey clay deposit of protoxide. In such cases the *till*, or stratum underneath, is composed of hard gravel, and frequently solid rock. This anhydrous oxide is sure to be mixed more or less with the superimposed stratum, and where it exists close to the surface the temptation is strong to add it to the mass of the hydrated oxide.

Regarding now the determination of the hydration of the peroxide, it will be readily perceived that this will vary considerably in different cargoes.

The amount of combined water, so as to determine the hydration, is easily estimated by true chemical analysis. A weighed quantity is introduced into a combustion tube, one end of which is connected with a weighed chloride of calcium tube, and this to an aspirating apparatus, the other end of the combustion tube being connected with a small chloride of calcium tube, to absorb any atmospheric moisture. The combustion tube is slowly heated to redness, and the aspirator set in action. At the end of the experiment the increase in weight of the chloride of calcium tube will give the weight of combined water in the oxide taken; or in the absence of an aspirator, a combustion tube with a closed end may be used, and connected with the chloride of calcium tube.

It is, therefore, a patent fact that anhydrous oxide does exist more or less in all our Irish bog oxide of iron, and that the existence of either oxides can be easily chemically determined. Other processes for determining hydration are being continually practised here, but I consider the foregoing the most accurate.

The whole subject is one of vast importance, and I will take an early opportunity of going into such further details as will not only prove to be interesting, but advantageous, to gas managers and users of our Irish bog oxide of iron.

The Dangers of Oil Lamps.

Messrs. S. B. Newbury and W. P. Cutter, of Cornell University, have published an article (it appeared in the *Scientific American*) upon the question of the safety of modern oil lamps. To determine this the experimenters selected three of the most powerful patterns of lamps now in vogue, including one fitted with a duplex burner, and compared the action of these with that of a lamp carrying a single flat wick one inch in width. So far as could be the same flames were tested with metal and glass bodies. In all cases the temperature of the oil was taken by means of a small thermometer, the bulb of which was immersed to a depth of an inch below the surface of the oil. The lamps were lit for 2½ hours before examination; and the effect of placing a white shade upon the lamp was also tested.

The result goes to show that the temperature of the oil in a metal lamp is higher by 1° or 2° than that of a glass lamp; and when a white shade

was put upon a metal lamp the temperature of the oil rose in a duplex lamp to 110° F. In a tubular wick lamp, with central air supply, the temperature was 104°. In the common single flat-wick lamp the temperature never rose above 94°. This burner may serve as the type of those generally used a few years ago; and by comparison with this the increased heat of the more powerful descriptions of lamps is clearly shown. It therefore appears that in various patterns of modern lamps the oil may be dangerously heated; and that in any case an oil which flashes below 120° is not suitable for use in a high-power lamp.

The Alavoine Plan of Hydraulic Main as Used in the Dijon Gas Works.

Something over two years ago the *Journal of Gas Lighting* published an illustrated description of an apparatus and method, devised by M.

him with special reference to the adoption therein of the Alavoine straining device.

The accompanying cut (it is reproduced from the *Revue Industrielle*) plainly reveals the method of working under what we may call the Alavoine-Leclaire plan. In the upper part of the hydraulic main, which is flat, there are several oval-shaped openings, A, arranged in zigzag order with the dip-pipes, whereby access is readily obtained to the strainers. These openings are closed by means of plugs of cast iron, the weight of which is sufficient to insure their tightness. The strainers are kept in position by two angle-irons, B, fixed on the vertical sides of the hydraulic main in such a way that the upper surfaces of the strainers are on the same horizontal plane. It will be seen that the gas is taken off at the side of the main, by means of a cast iron pipe communicating with

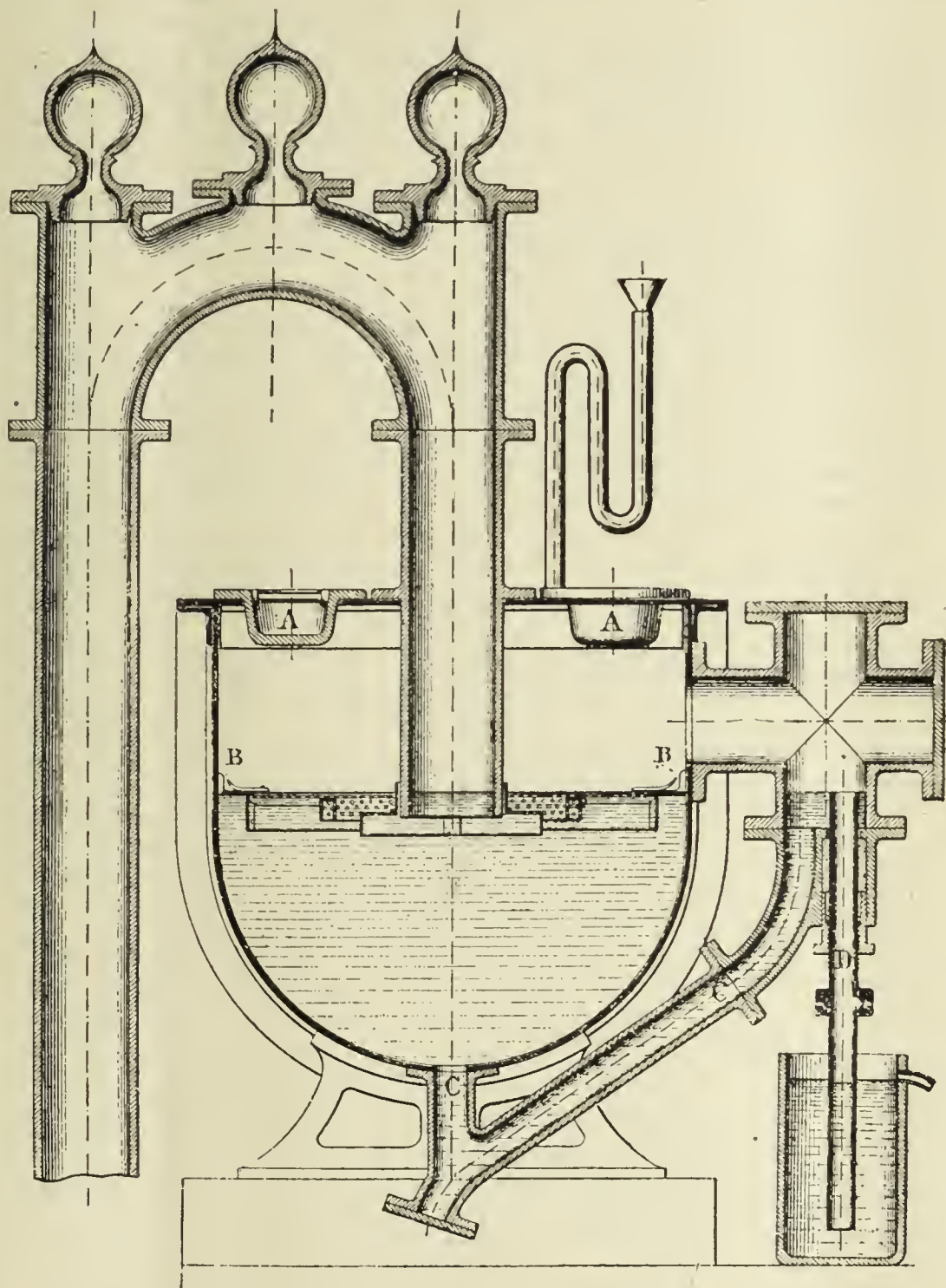

Alavoine, Superintendent of the Beauvais gas works, for separating, in the hydraulic main, the heavy properties of gas, and for generally facilitating condensation. The appliance consisted of two perforated plates, fixed at a certain distance above each other, and forming a kind of shallow box, attached to the bottom of the dip-pipe, so that the gas had to travel under water for a distance of about two feet before passing out of the hydraulic main. In this way not only was there a more complete condensation with less pressure, but the quality of the tar was improved. The arrangement of perforated plates, to which the far from inappropriate name of "strainer" was given, was applied by M. Alavoine to a number of dip-pipes at the Beauvais works, with very satisfactory results.

At the Paris meeting of the Societe Technique de l'Industrie du Gaz en France last year, the inventor gave an account of his further experience with the appliance; while at the Nancy meeting (1887) of the French Association M. Leclaire described a hydraulic main designed by

the collecting main by a valve. The cooling of the main is effected by sending in a stream of ammoniacal liquor through the S-pipe fixed upon the lid. The heavy tar is removed by the pipe, C, which discharges the excess of tar into another pipe, D, which dips into an overflow vessel. This pipe, which is screw-threaded on a portion of its upper outer surface, passes into a stuffing-box, the cast iron cap of which is also threaded internally. By turning the pipe the level of the liquor in the hydraulic main may be raised or lowered—an operation which can be performed without the least inconvenience while work is going on. It is claimed for this arrangement that by it the minimum of dip is insured in all cases; while at the same time there is no possibility of the gas passing back into the ascension-pipes at the time of charging the retorts. Four hydraulic mains on this system have been installed in the new gas works at Dijon on a similar number of settings of nine retorts, placed back to back; and at the date of the French Society's meeting two of the benches had been working satisfactorily for three months.

ITEMS OF INTEREST FROM VARIOUS LOCALITIES.

NOTICE TO LIGHTING CONTRACTORS.—Mr. J. F. Cunningham, Chairman of the Board of Trustees of the "California Hospital for the Chronic Insane," which institution we believe is located in the city of San Jose, Cal., has been authorized to receive "plans, specifications and bids for constructing, furnishing, setting up and putting in satisfactory and successful operation a system of lighting for said Hospital, either by electricity, coal gas or gasoline gas." The time limit for the reception of bids will expire at 6 o'clock P. M., Monday, Oct. 24. The bids must be accompanied by a bond in amount equal to 10 per cent. of their face value. The "bids are to include the cost of the plans and specifications, which said plans and specifications presented by the successful bidder are to become the property of the Hospital upon the awarding of the contract to such bidder or bidders."

APPOINTED SUPERINTENDENT OF LAMPS.—The Board of Commissioners for the District of Columbia have appointed W. H. Harrison to the position of Superintendent of Public Lamps, vice H. O. Bailey. Supt. Harrison took charge on October first.

CHEAPER GAS FOR STOCKTON, CAL.—Mr. Henry Adams, Supt. of the Stockton Gas, Light and Heat Company, has been empowered to again furnish practical proof of the spirit that actuates those who control the Company's affairs. Bro. Adams' pronouncement, which bears date of Sept. 20, is as follows: "On the first day of November next the price of gas will be reduced to \$2.75 per 1,000 cu. ft. The Stockton Gas, Light and Heat Company, takes pleasure in renewing the assurance of a continuation of the same liberal policy governing it in the past, and will avail itself of all improved methods for cheapening the cost of gas to our citizens. We propose to continue to furnish a superior light at the lowest possible price, even less than is charged in any other city of this State containing at least twice our population." That is the way to talk—and to act.

PUBLIC LIGHTING, JERSEY CITY, N. J.—The following are the bids submitted by those in interest for the public lighting of Jersey City and suburbs: United Gas Improvement Company—not less than 925 posts in old Jersey City and Lafayette, at \$18 per post per annum; not less than 1,225 posts in old Bergen and Hudson cities, at \$19.50 per post per annum; not less than 125 posts in Greenville, at \$25 each per annum. The Company proposes to submit to a deduction of 2 per cent. for each lamp "out" on an average of 1 night per month during the year. In the proposal the Company adds the following clause: "These bids are made subject to the condition that the city shall in the contract pay to the Company \$75 per month to cover damages caused by extraordinary breakage of lantern glasses and the replacement of same. This condition is made necessary by past experience, the protection afforded the lamps not being sufficient to prevent the constant and wanton breakage of glass by mischievous persons whose destructive acts ought to be prevented by the city." [The stand thus taken is an eminently proper one, and ought to be imitated by every gas company in the country.] The New York and New Jersey Globe Gas Light Company offered to maintain from 1,000 to 1,500 naphtha lanterns, at the rate of \$1.62½ each per month. The Jersey City Electric Light Company offered to maintain 40 electric lights, or above or below that number at the rate of 40 cents per lamp per night, that price to be reduced to 33 cents per night in case the arcs are maintained in duty each and every night in the year.

PUBLIC LIGHTING AT LITTLE ROCK, ARK.—The residents of Little Rock are anxious that some portion of their public lighting should be accomplished under the arc method. In order, if possible, to satisfy their demands, Mayor Whipple and the Board of Public Affairs are carrying on negotiations with the local gas and electric light companies, with a view to perfecting a plan whereby the gas lamps on some of the leading business streets shall be supplanted by arc lights.

MAKING IT PLEASANT FOR THE COMPANY THAT PROPOSES TO WORK UNDER THE HALL PATENTS.—A month ago we announced the incorporation of the Zenith Gas and Water Company, to operate in Duluth, Minnesota, under the system of gas manufacture outlined in what is known as the Hall patent. Mr. Wm. Craig, General Manager of the old Duluth Gas and Water Company, proposes to give the new comers an excellent opportunity of showing how cheap gas can be made and sold under the Hall process. In fact, Mr. Craig, on behalf of the old company, has published a schedule of selling rates, to take effect from first instant, that ought to "cure" the Hall people of their desire to

compete with those already in possession of the Duluth field of gas supply.

CHEAPER GAS FOR PORTLAND, OREGON.—The proprietors of the Portland Gas Light Company have decreed that from and after first instant the net price of gas shall be adjusted at the figure of \$2.50 per thousand cubic feet. We believe that this signifies a reduction of 25 cents per thousand. It should be added that the concession now made public only takes effect on accounts settled within 3 days from the presentation of bills.

PUBLIC LIGHTING AT EAST ALBANY, N. Y.—The village trustees of East Albany, or Greenbush, have closed a contract with the East Albany Gas Company, under which the latter agrees to maintain any desired number of gas lamps in consideration of the receipt of 9½ cents per lamp per night. The lights are to be in duty all night and every night in the year. The Company is to light, extinguish, and clean; and the burners are rated to a duty of 4 feet per hour.

A GOOD EXHIBIT.—A most interesting exhibit at the Chicago (Ills.) Exhibition is that made by the Chicago Gas Stove Company. The "dollar gas" that prevailed during the protracted war of gas rates in the wonderful Metropolis of the West taught one important thing to the Chicago housewife—that a gas cooker was and is an unalloyed blessing.

GETTING READY.—The city having awarded a contract for a mixed system (gas and electricity) of public lighting to the Cohoes (N. Y.) Gas Light Company, the proprietors of the latter have purchased the property formerly occupied as a site for a paper mill—it is close to the best dam on the Mohawk river—and are getting the structure in readiness for the dynamos. Wiring operations are being vigorously prosecuted.

BURYING THE HATCHET.—We understand that the Westinghouse Electric Light Company, of Pittsburgh, Pa., and the Thomson-Houston Electric Light Company, of Boston, Mass., will amicably terminate all existing difficulties by consolidating their forces. All suits between the Companies have been withdrawn.

GAS TRUST (ST. LOUIS, MO.) ELECTION.—Advices from St. Louis, dated Oct. 5, say: "The St. Louis Gas Trust election yesterday was a very tame and one-sided affair. The victorious interest went into the contest with over 30,000 shares pledged to it, and as that meant a clear majority of all the certificates in the Trust, the representatives of the anticipated opposition simply threw up their hands, thus permitting the uncontested election of Messrs. W. H. Thompson, James O'Connor, John R. Lionberger, H. L. Newman, and W. W. Gibbs as a Board of Trustees. At a subsequent meeting of the Board Mr. W. H. Thompson was chosen President. 38,880 shares were voted."

APPOINTED AS SUPERINTENDENT.—Mr. Henry T. Hardcastle has been appointed Secretary and Superintendent of the Appleton (Wis.) Gas Light Company. We wish him all possible success.

DO THE PEOPLE WANT IT?—Articles incorporating the Peoples' Gas Company, of Fort Wayne, Ind., have been filed with the Secretary of that State. The capital stock is placed at \$50,000. Perhaps this is another sample of the Tooley street tailor's famous "resolve." Then, again, perhaps it is simply a natural gas speculation.

PUBLIC LIGHTING PROPOSALS, BUFFALO, N. Y.—Buffalo advices state that proposals for supplying the city with light, for one year from 1st. inst., were recently submitted to Councils. The Buffalo, Mutual, and Citizens Gas Light Companies offered to supply gas at the uniform rate of \$1.35 per thousand cubic feet, and to keep up repairs to public lamps at the rate of 17 cents per post per month. The United States, Brush, and Thomson-Houston Electric Light Companies offered to maintain arc lights at the rate of 47½ cents per light per night. The bids were referred to the Committee on Lamps and Gas. During the discussion one astute City Father, in the person of Alderman White, expressed the grave opinion that the gas companies had been in the habit of "mixing gasoline with the gas supplied to the public lamps." He meant it, too; for, at his suggestion, the City Chemist was added to the Committee on Lamps and Gas, the "addition" being instructed to find out whether the gas men were as black as intimated by City Father White.

MARYSVILLE'S PLIGHT.—A Columbus (Ohio) correspondent writes: "I notice that you mentioned something in the JOURNAL about the Marysville (Ohio) struggle for a gas works, which leads me to say that the residents there have a most interesting fight on hand concerning this

topic. The present Marysville Council was elected on the prohibition issue, but, having occupied their seats in perfect ease and quiet for some time, they finally managed to 'raise another issue.' In hunting over the former records it was discovered that an election had been held in the town a few years ago, and the matters then balloted for, it seems, included the question whether or not a gas works should be built. The 'ayes had it,' and it was further proved that the State Legislature, by special enactment, authorized the Council to issue bonds for the erection of the coveted plant. The Council then in power, presumably for financial reasons, concluded not to exert its authority in the premises; but the present body assumed the responsibility—at least it went so far as to advertise for the sale of the bonds, and invited contractors to tender for the work. In the meantime some of those (and I fear they included many who did not greatly favor the prohibition issue) opposed to the idea—candor compels me to add that the objectors consisted largely of the tax-paying members of the community—petitioned the Council to defer the gas works project, for a time at least. The petition was granted no attention whatever, and the signers then prayed for a writ of injunction, which was temporarily allowed. The argument to make it permanent was heard at Bellefontaine, before Judge Coats, in the latter part of September, but I have not been advised as to his rulings in the case. However, that lack of information, as regards the Coates decision, is not material just now; for in any event the case will be appealed to the Supreme Court, which fact insures the retention of the gasoline public lamp at Marysville for some time to come."

THAT HAMILTON (OHIO) SUIT.—The Hamilton Gas Light and Coke Company has, in the local Court of Common Pleas, brought suit against the Cincinnati & Richmond Railroad Company, alleging as cause for action that it owns an individual interest in 110 feet of ground, fronting on High street, and extending back to the center of an old gasholder tank; that the defendants have already entered thereon with their tracks without consent from or compensation to the plaintiff; that the defendants are about to still further similarly enter thereon, and that such action will greatly interfere with and injure the gas works, etc. Plaintiff, therefore, prays for an injunction, or the issuance of an order compelling defendants to pay over a fair compensation for the right of way. A temporary restraining order was issued, and a day has been named for arguing the merits of the case. Our informant adds that "this dispute is apparent rather than real, although the gas men are far from being satisfied at the dilatoriness of the railroad folks in keeping up to their agreement. Some 3 months ago everything relative to the passage of the Pan Handle road over the land in question was settled upon between the parties, and the railroad folks assert that the preparation of the papers was only prevented because of other urgent matters that cropped out relative to the management of the road. It is well to note, nevertheless, that the urgency of the outcroppings did not prevent the railroaders from seeking to put down their rails over the coveted territory. For my part, I think the Hamilton gas men acted wisely and well, for 'an ounce of prevention,' etc., seems to suit this case quite neatly."

ANNUAL MEETING, CONCORD, N. H.—At a recent meeting of the Directors of the Concord Gas Light Company, the following officers were elected: President, John Kimball; Treasurer and Agent, John M. Hill; Clerk, Sylvester Dana. It was decided that the President and Treasurer be appointed a committee to make arrangements for the construction of a new gasholder, to be erected on the plot of land, on Turnpike street, recently purchased from Mr. Woodman. The holder is to have a capacity of not less than 100,000 cu. ft. The Directors also resolved to lower the dividend rate to 8 per cent. (10 has been the rule) until the holder expense had been wiped out. The company is in a prosperous condition, but there is small cause for wonder at that for its fortunes are controlled by wise and progressive men.

ANOTHER GAS COMPANY FOR SAN FRANCISCO, CAL.—The Standard Gas, Light and Fuel Company, to manufacture and sell gas for illumination and fuel to the city and residents of San Francisco, has been incorporated. Henry McGurren, of Chicago, Ills., Wm. B. Cluff and Jas. D. Boyer, of Alameda, and Benjamin B. Duncan and William F. Harris, of San Francisco, comprise the Directors. The capital stock is fixed at \$3,000,000.

OBJECTING TO THE CHOICE MADE.—Owensboro, Ky., is not an exceedingly large place, but it seems to have sufficient attraction for gas works builders, or speculators in such operations. At any rate the owners of a new company chartered for the locality purchased a plot of land whereon to erect a works, the site selected being in the neighborhood of

St. Stephens Church—a part of the city where many small residences are located. The church congregation and others of the surrounding property holders have addressed a petition to the City Council strongly remonstrating against the granting of a building permit, claiming that a gas works would not only be a great nuisance, but would also seriously impair the value of their property.

NO LONGER IN CHARGE AT POTTSTOWN, PA.—Mr. J. J. H. Bassett, who for the past 18 years acted as Superintendent of the Pottstown Gas Light Company, has resigned that post. Here is a chance to secure the services of a thoroughly competent and reliable man.

CONTRACT AWARDED.—Messrs. Mayher, Robinson and Flockhart have been awarded the contract for furnishing lamp posts to the city of Newark, N. J. We understand that \$5 10 per post was the price agreed upon.

CHANGED HANDS.—Mr. C. W. Lobdell informs us that he has disposed of his interest in the franchise and plant of the Moline (Ills.) Gas Light Company; but fails to mention the name or names of those who made the purchase. We are right sorry that Mr. Lobdell has determined to step down and out.

THE SALE IS OFF.—Some time ago we announced that a syndicate, acting through Messrs. Goff, Stedman, and Sawyer, had arranged for the purchase of the Saco and Biddeford (Maine) Gas Light Company. It was supposed that all the details of the transfer had been perfected, and that by now the syndicate would be in actual possession of the property. Advices from Biddeford, under date of 5th inst., go to show that the syndicate failed to complete the agreement. Our correspondent says: "The initial steps at negotiation were taken last May, when the syndicate made an offer to President Woodman for the purchase of the plant. He refused to accept the offer then made, but named a price at which he would sell. They asked for time to consider the proposition, and the request was acceded to. The option period was subsequently extended for five weeks, or until Aug. 10; but the latter date found them still unable to complete the purchase. The syndicate then communicated with Mr. Woodman with a view to securing a third extension of time, and he declared his willingness to keep the matter open until Oct. 1, provided they posted a forfeit to prove they really meant business. The forfeit sum was deposited, but the designated day brought a despatch requesting additional grace, the saving power of the latter to become valueless at 3 P.M. of Oct. 4. On the evening of said day the gentlemen in whose hands the forfeit had been placed wired Mr. Woodman that the stock had not been taken up, and the option was no longer good. Had the sale been consummated the Kennebec electric light plant would have been removed to the gas works, and both systems of lighting thus centered in one control. While the negotiations were pending Mr. Woodman delayed the carrying out of the changes contemplated by him last spring in the carbonizing plant of the gas works, but these will now be pushed vigorously forward. Regenerative furnaces are to be introduced, the material for which construction is already on the ground. I was opposed to the sale, and am therefore inclined to say, 'All's well that ends well!'"

OTHER MAINE GAS NEWS.—We are in position to say that the Kennebec Light and Heat Company, having purchased the franchise and works of the Augusta (Me.) Gas Light Company, will make extensive alterations to the newly acquired plant. A new holder will be erected. The manager of the Company is Mr. J. W. Averill.

CHEAPER GAS FOR BELLEVILLE, ONTARIO.—Mr. S. R. Earle, Manager of the Belleville Gas Company, has been authorized to say to the residents of his city that, beginning with first day of current month, "the price of gas will be \$2.25 net per thousand cubic feet. The bills will be rendered at \$2.50 per thousand, and a discount of 10 per cent. given if accounts are paid at the Company's office on or before the 20th of the month." The extension of the discount period to the 20th of the month certainly affords ample time for all customers to secure the benefit of the Company's concession in the line of cheaper gas. The rate charged for gas used for domestic and power purposes remains as before—\$1.25 per thousand.

PUBLIC LIGHTING AT TRENTON, N. J.—It is reported that a contract for electrically lighting the streets of Trenton has been awarded to the People's Electric Light Company. The price to be charged is 50 cents per light per night.

WHAT THE CONSOLIDATION MAY MEAN.—Elsewhere we report the fact that the Westinghouse and Thomson-Houston Electric Light Com-

panies have agreed to consolidate their interests. An exchange, in alluding to the consolidation, says: "The consolidation of the Companies named is looked upon as being very significant by electricians, who assert it is the beginning of a combination that is to extend all over the country, in opposition to Mr. Edison. The latter was recently granted a patent for the multiple arc system of distribution, which, if sustained by the courts, will give Mr. Edison absolute control of the incandescent system, and will compel the Westinghouse people, and all of the other companies now supplying incandescent lights from a central station as well, to either abandon their business or pay tribute to the erstwhile Wizard of Menlo Park. The especial patent granted to Mr. Edison covers the plan of distributing electrical power to a system of incandescent lamps from a common station, and under that protection Mr. Edison can bring suit against all of the other incandescent systems for infringement. The effect of the granting of this patent has been to unsettle the values of other incandescent electric companies, but as Edison will be compelled to bring suit in the courts to establish the truth of the charge of infringement upon his patents by other companies, there is a vigorous legal fight in prospect—unless compromise suggests a way in which the conflicting interests may be harmonized. In any event, the Westinghouse-Thomson-Houston amalgamation makes the position of these properties much more secure than if their interests were divided."

A TABLE OF PRICES PAID FOR ARC LIGHTS.—The following table shows the number (and cost per night) of public arc lights maintained in the cities and towns enumerated:

	No. Arc Lights in Use.	Price each per Night, in Cents.
Auburn, N. Y.	42	27.4
Albany, N. Y.	481	50
Atlanta, Ga.	40	39
Buffalo, N. Y.	546	60
Binghamton, N. Y.	100	50
Boston, Mass.	501	65
Baltimore, Md.	489	50
East Saginaw, Mich.	100	27.4
Fitchburg, Mass.	43	24.7
Fall River, Mass.	180	58.3
Gloucester, Mass.	11	26.6
Galveston, Texas.	50	72
Haverhill, Mass.	27	47
Ithaca, N. Y.	94	40
Knoxville, Tenn.	30	32.9
Kansas City, Mo.	27	55
Lowell, Mass.	100	55
Lockport, N. Y.	28	37
Meriden, Conn.	28	41
Minneapolis, Minn.	306	50
New York, N. Y.	1576	20 to 60
New Haven, Conn.	102	55
Norfolk, Va.	145	28.8
Nashville, Tenn.	30	50
Providence, R. I.	175	50
Peoria, Ills.	235	34.2
Poughkeepsie, N. Y.	184	35
Rochester, N. Y.	890	27
Reading, Pa.	100	45
Syracuse, N. Y.	133	39
St. Paul, Minn.	...	50
Salem, Mass.	142	47
Sandusky, Ohio.	45	24.7
Troy, N. Y.	255	47
Toledo, Ohio.	47	50
Terre Haute, Ind.	210	24.1
Utica, N. Y.	53	53
Vicksburg, Miss.	40	40
Watertown, N. Y.	90	18.6
Worcester, Mass.	113	55
Woonsocket, R. I.	41	50

Of course, in many of the places named a moon-table is followed, but we are unable to separate these with certainty. The table is a very suggestive one. The lighting value in each case cited is returned at 2,000 candles, save in New York city.

TAXES PAID BY SOME NEW YORKERS.—The receiver of Taxes for New York city (Mr. G. W. McLean) is now gathering in the shekels of those who rejoice in the possession of the "unearned" (or earned; which is it?) "increment" that occasions such great trouble to the washed and

unwashed followers of Henry George. We mention Mr. McLean's present occupation simply for the purpose of making it apparent that the checks so far received by him included one for \$223,310.96, drawn to the order of the city by the officials of the Consolidated Gas Light Company.

A SPRINGER APPARATUS FOR EMPORIA, KANSAS.—The National Gas Light and Fuel Company is under contract to erect a set of Springer gas-making apparatus at the works of the Emporia, Kansas, Gas and Electric Light Company. The plant is to have a capacity of 120,000 cu. ft. per diem. The cupola is to be of the new "pitcher-spout," solid arch pattern, similar to that in use at Lima, Ohio.

AN EXPLOSION AT TORONTO, CANADA.—People promenading along King street (Toronto), close by where it crosses Yonge street, were, on the morning of October 4th, somewhat startled by a loud explosion. The shock to their ears was speedily followed by a surprise to their eyes, when they beheld the windows of H. L. Hime & Co.'s brokerage office making a bee-line for the center of the street, closely pursued by the flying forms of two of the clerks of the dismantled establishment. The first explosion was succeeded by others of a less severe nature, but with the general result that Hime & Co. will have to expend several hundred dollars before their counting-room shall have assumed its normal appearance. The aforesaid clerks were not much the worse, bodily, for their unconventional flight, and the others of the Hime force, including that gentleman himself, luckily escaped serious injury. Some weeks or so before the explosion, the basement and cellar in the rear of the store had been occupied as a workshop by an agent of the Toronto Portable Gas Company, and it is presumed that when the agent "moved" he neglected to take away all the "chemicals" used in "generating the gas manufactured on the premises." By way of explanation it may be said that the Portable Company's gaseous article turns out to be an old acquaintance, since the ingredients used to produce it are "sulphuric acid, marble dust, water, iron and coal oil." The furnace that heats the Hime building is located in the basement of what formerly filled the function of a gas works, and as a fire was first needed on the day of the disaster the cause of the latter is made somewhat plain. Therefore, we would say, "Rent not your cellars to makers of portable gases."

A MARYLAND COMPANY AND ITS PURPOSES.—Articles incorporating the Consumers Water and Illuminating Company, of Baltimore County, have been filed. The Company, according to those who created it, is formed for the purpose "of supplying pure water and illuminating gas to the towns of Woodberry, Woodlawn, Hampden and their vicinage, and for acquiring property, maintaining buildings, and manufacturing and selling gas," etc." Messrs. J. D. Mallory, R. J. Capron, Wm. M. Busey, G. B. Morton and W. H. Watkins, comprise the Board of Directors. The capital stock is \$200,000.

NOTES FROM THE WEST, BY "RETORT."—"Coal gas men have long been under the impression that the little irregularities practiced by their patrons were based on the desire of the latter to 'get even' with the former; but we now learn that our natural gas suppliers, who almost give their commodities away, are experiencing troubles like unto those of our own, since we find it reported that the Youngstown (O.) Natural Gas Company, through its Inspector, recently discovered that some of the consumers were 'boring out' their burners. In one instance the Company found that a consumer who was paying for the quantity of gas that would pass through a No. 3 burner, had, by careful boring, managed to make it equal the capacity of a No. 7.—Winfield, Kas., is to have an arc and incandescent electric light plant, the same to be owned by the city. Bonds are to be issued to meet the expense incurred.—Mr. Conway, Secy. of the Wichita (Kas.) Gas Light and Power Company, is pretty busy just now. In addition to putting down a large amount of new main pipes, he found it necessary to thoroughly overhaul the old ones because of a largely increased leakage account. The services gave out rapidly, too—the trouble in both instances can be traced to peculiarities in the soil of the vicinity—and they are to be replaced by galvanized iron pipe. The city has recently ordered 100 additional street lamps. Mr. Conway is also erecting a very elaborate gas arch, spanning Main street, to the order of the local Museum Company.—The Bellevue (Ky.) Company, mention of whose novel plant was made in my last letter to the JOURNAL, seeks new territory for conquest. Its proprietors have cast their hook into Newport, and the City Council seems to be nibbling at the bait. A legal fight is anticipated, and apparently provided for.—Gen. Hickenlooper's return to Cincinnati from his wanderings in foreign lands was made memorable by the rousing reception given him by the employees of the Cincinnati Gas Company. Speeches, music, flowers, and cheers were showered on him

almost before he crossed the sidewalk in front of his house. Although somewhat taken aback, the General met the volley of goodwill in thoroughly characteristic fashion."

KILLED BY THE CURRENT.—Sept. 25, F. Nelson, in employ of Brush Company, Philadelphia, Pa. Oct. 3, H. Corliss, lineman, Brush Company, Detroit, Mich.

A NEW SOUTHERN ENTERPRISE.—On Oct. 8 the Jeter and Boardman Gas and Water Association was incorporated at Macon, Ga., with a capital of \$200,000. The object of the Company, as indicated by its title, is to build, operate, lease or purchase gas, water and electric light works throughout the "New South." Its officers are: W. A. Jeter, of the Brunswick (Ga.) Gas Company, President; A. E. Boardman, of the Macon (Ga.) Gas Company, Secretary and Treasurer; and Messrs. J. W. Wilcox, J. H. Campbell, and J. S. Scofield (all of Macon), Directors. We wish the new venture every success, and must say it starts out quite promisingly, having already secured the right to construct water works at Sumter, S. C., also at Ocala and Tampa, Fla.

Gas Into Electricity.

A recent issue of the Boston *Sunday Herald* said:

In its September number *Practical Electricity* has an interesting account of "an unique lighting plant" in Spencer, Mass., in which gas furnishes the motive power, and by means of gas engines and dynamo machines is transmitted into electricity for lighting purposes. Some thing over a year ago the *Herald*, in an article on gas and electricity, ventured the prediction that the time would come when a better and more intense illumination could be had from gas by means of the gas engine and dynamo electric machine than from the gas itself; and, according to the article in *Practical Electricity*, this has been accomplished in Spencer. From the account in that journal, it appears that early last spring the gas company of Spencer—of recent establishment—began to consider the question of electric lighting, and first tried the experiment of operating 25 arc lights in the town by means of a single 10-horse power gas engine and a small steam engine belted to counter shafting. Although not a success from an electrical standpoint, the people of the town were immensely pleased, and, in a public meeting, they voted, authorizing the selectmen to make a contract with the Spencer Gas Company to furnish 60 arc lights for one year, at 33½ cents each per night. Three new Otto gas engines were purchased, an extra dynamo, additional lamps to make a full quota of 60, and the necessary wiring was also accomplished. On the first day of last July the entire plant was put in operation, and has been successfully operated since that time.

A visit by a representative of *Practical Electricity* to the plant at Spencer gives sufficient data and evidence to show that gas can be cheaply and successfully used to do an electric lighting business. Three Otto gas engines, with an indicated total capacity of 45-horse power, were operating two Ball dynamos. The dynamo pulleys had a speed of 1,200 revolutions; but of the 45-horse power of the engines the writer estimated that the dynamos actually received not more than 36-horse power of energy. "Nevertheless," he writes, "both engines and dynamos worked magnificently, and will work better after having been longer in use. Taking both engines and dynamos at their best at this rating, sufficient power was given off to successfully operate at least 20 more lights. The amount of gas consumed in the run of 4½ hours was 3,910 cubic feet. Calling it in round numbers 4,000 cubic feet, there was an expense for fuel of \$2, the cost of the gas being rated by the Company at 50 cents per thousand cubic feet. Hence the cost of the 60 lights on the circuit was 3½ cents per lamp for 4½ hours' run. It will be seen, further, that, in this case, the dynamos were operating very nearly two lamps per horse power. The writer has not the smallest doubt of the approximate accuracy of the above figures. Finally, it may be said that the only items of expense to be figured into the cost of operating these lights are the salary of the man (\$15 per week) who looks after the station and the lamps and conductors also, the cost of the carbons, and the oil used for lubrication. The rental of the room is virtually nothing."

Correspondence

[The JOURNAL is not responsible for the opinions expressed by correspondents.]

Tar Pavements.

OFFICE OF STRATFORD GAS COMPANY, }
STRATFORD, ONTARIO, Sept. 29, 1887. }

To the Editor AMERICAN GAS LIGHT JOURNAL:

I read with much interest your report (contained in issue of JOURNAL for Aug. 2) of the discussion, at the meeting of the Western Gas Asso-

ciation, on the uses to which the tar made on gas works may be put. Noting that many of the members of the Association seemed to have been quite successful in constructing tar-made roadways or footwalks, and having had some experience in that direction I thought that a description of the method pursued here would be acceptable to your readers. From one cause or another I deferred that recital till now, for we are at the present time using up in the manufacture of asphalt walks the tar made in our works since last June.

At first, or about ten years ago, by way of a trial, we used tar mixed in with common cinders in our plan of sidewalk construction. We took the cinders as they came from the furnaces adding sufficient tar to thoroughly saturate them, and placed the mixture (about 4 or 5 inches in depth) over a piece of footwalk that had a good clay bed. The mixture was then rammed and rolled until it had been thoroughly packed. Now, although I may say that that section of footway shows no sign to-day of wear and tear, we have done a good deal of experimenting since then with the result that we claim to be able to make a first-class tar sidewalk not only at much less expense, but also a much more durable footway is secured, than if wood were employed. Further, we get as good price for our tar as any that I have seen reported in the JOURNAL. I may say we have either ourselves mixed or sold to others for asphalt mixing purposes, all the tar made by us during the last four years, and the demand is rapidly increasing. In fact our City Council have passed a resolution authorizing the local Board of Public Works to contract with us for a supply of asphalt for next season.

Our process of preparing the material is to first crush the cinders quite fine (we subsequently pass them through a screen fitted with a 1-inch by ¾-inch mesh), and then add coarse, clean sand to them—using the same screen—in the proportion of 2 parts sand to 1 part cinders. To 1 cubic yard of the compost we add about 0.75 of a barrel of tar, and with rakes thoroughly mix the mass until it, for want of a better expression, acts like thick brown sugar does when the latter is disturbed by the hand—that is, it appears to "crawl" on being moved. At first our mixing process was a slow operation, but practice taught us how to advance. By means of the apparatus now in use we can mix quite rapidly. In fact, with three men, we are able to mix 10 cubic yards per day; and that quantity is taken by the city, the authorities removing it from our premises. The city puts this pavement down, and makes a charge of \$5 for each cubic yard.

We erected a furnace to heat the compost, and the following will describe its features: The heating pan (it is estimated to contain 1 cubic yard) is made of boiler plate, being 10 feet long by 4 feet wide, and 9 inches high, on three sides, the remaining side being open in order to facilitate shoveling. Pieces of T-iron are riveted on the bottom of the pan, in order to prevent warping because of the fire underneath. This pan is placed on a brickwork structure, which rises about 2 feet from the ground, built furnace fashion, with furnace door and grate bars, and a stack in the rear. By using a very small quantity of wood we are able to heat 1 cubic yard of the composition as fast as the men can prepare another.

The tar is pumped directly into a caldron that is arranged with a coil of pipe through which steam is passed. Thus it is seen that all the components of the mixture are kept in a heated state, and that the operation is easily and readily performed.

The composition (asphalt, we call it here) is spread to a depth of 3 inches over a properly prepared bed lined out in just the shape required to be taken on when finished—the Stratford authorities have usually put the mixture over a specially-prepared gravel bed, but that precaution I consider unnecessary. Indeed, some two years ago I experimented with the mixture on a simple clay bed, and I firmly believe, from the teaching of that trial, that the clay-bedded walk will outlast the gravel-bedded ones. I am satisfied that anything of an over-porous character will not answer for a tar walk foundation, for the underneath drying-out action must cause cracking in the upper mass. On the other hand, a solid, firm bed will hold the under side of the asphalt in an elastic manner, with durability as the result.

At Stratford we give these tar made walks no protection when once they are finished. The finishing process consists in rolling them thoroughly with a 700-pound roller—sprinkling a little fine sand over the mass when it is spread, in order to keep the roller from tearing up the mixture. When the rolling is completed the walk is covered with a nice coat of thin sand, and the footway is ready for use.

Believing that I have occupied too much of your space, nevertheless if our experience here in this instance in disposing profitably of a by-product in gas making is worth anything to the fraternity, I shall feel grateful.

Yours truly,

JOHN READ, Manager.



A. M. CALLENDER & CO.,
PROPRIETORS.

Editor—JOS. R. THOMAS, C.E.
Asst. Editor—T. J. CUNNINGHAM.
Manager—C. E. SANDERSON.

PUBLISHED ON THE 2ND AND 16TH OF EACH MONTH
At No. 42 Pine Street, New York.

This is a recognized official organ of—
LIGHT, HEAT, STEAM, WATER-SUPPLY,
VENTILATION, SANITARY IMPROVEMENT
AND GENERAL SCIENCE.

TERMS

SUBSCRIPTION—Three Dollars per annum, in advance.

AGENTS

NEW YORK—AMERICAN NEWS Co. 39 and 41 Chambers St.
BOSTON—S. M. PETTENGILL & Co., 6 State Street.
PHILADELPHIA—PRATT & Co., Corner 9th and Arch Streets.
England—C. W. HASTINGS, 22 Buckingham St., London, W.C.
Germany—B. WESTERMANN & Co., of New York

MONDAY, OCTOBER 17, 1887.

Western Waifs.

By DIAPHRAGM.

Your correspondent, on the occasion of a recent visit to Jacksonville, Ills., found the urbane King indisposed. It was a question whether he would feel able to endure the fatigue consequent on the journey East to attend the convention. It is to be hoped he will show up, smiling and entirely well. He has been very busy indeed. Jacksonville has paved a mile and a-half of her streets, thus far this season, and the Gas Company has relaid on these streets larger mains, renewed every old service, and put in services to curbstone on each vacant lot on the line. There is yet as much more to do before December. Two new settings of 5's are going in, a new meter room (32 by 18) is under way, and a new 5-ft. station meter is being built. Considerable water pipe has also been laid, to serve as an additional fire protection. The day consumption is increasing. Besides a number of engines more than 100 gas stoves are in use. That the coke trade is good is evidenced by the fact that the Jacksonville Gas Light Company is more than 3,000 bushels behind the orders now on the books for that residual. Among contemplated improvements for next year I note a new holder (60 ft.), and a building to house additional electric plant. By the way, Mr. King has for sale purifiers, condensers, hydraulic main, and other apparatus that go to make up a six-inch plant. The present Jacksonville plant is an 8-inch one throughout.

President Wakelee, of the Battle Creek, Mich., Company, reports a steady gain in business. They have put in a new setting of sixes, and completed over a mile of main extensions this season. Next year much more work will be necessary.

Said Supt. Decker, of Hannibal, Mo., "Our town is not booming, as all Western towns ap-

pear to be. Our growth, however, is steady, and the Gas Company's business increases in similar manner. We have no reason to complain, and prospects are bright. We have done nothing in the way of extensions or improvements. How is the water company? Powerful busy; me, too."

Dame Fortune has smiled kindly upon Col. John Dell, of St. Louis. Unearthing his money from fireclay mines, the Colonel invested in silver mining stocks, all of which turned out well—particularly, one block of 2,000 shares (purchased at 25 cents per share) is now worth \$1.25, and none selling. John's many friends will be glad to hear of his good luck.

The expiration of electric light contracts at Vincennes, Ind., is keeping Supt. Ramsdell quite busy. His report at the end of the fiscal year shows an increase of 20 per cent. in consumption—very gratifying, certainly, to Mr. Ramsdell and his directors. The Laclde people are building a new bench of sixes—half regenerative—for Vincennes.

"The improvements at St. Joe, Mo., are progressing rapidly, and it is hoped to have everything in order by Nov. 1," said Secretary Farish, to the writer, recently in St. Louis.

The many friends of Supt. Cannings, of Henderson, Ky., will sympathize with him in the loss of his son, a bright young man of 24 years, who was buried Oct. 2. The project agitated in the City Council to light the streets of Henderson with electricity has been abandoned—gas is good enough. A new bench of 6's (Evens & Howard) has been erected, and a new tower condenser and scrubber (from Stacey Manufacturing Company) was placed on the first of this month. Business has been beyond Mr. Cannings' most sanguine expectations. Next season another bench of sixes, and a new rotary exhauster as well, will be added to the plant.

President Griswold, of the East St. Louis Gas Company, having disposed of his valuable Forest Park property, has bought a house in and taken up his residence at Castleton, Vt. Pretty far away, eh? He still retains his interests at E. St. Louis, and, under Supt. Ewing, good results are guaranteed. Over a mile of new pipe has been laid this season to meet the demands of a rapidly increasing consumption. Besides extending the retort house and adding therein a new bench of 3's, besides other improvements on the plant, three very nice cottages have been erected, in close proximity to the works, for the use of the men in the employ of the Company. Much new work is laid out for next season.

Your scribe had a pleasant visit last week with "Gus" Littleton, at Quincy, Ills. Though very busy the weary traveler was received and granted a hearing. Although no improvements worthy of mention were made at the Quincy plant this year, the purchase, on the 1st inst., of the local electric lighting company by the Gas Company marks an important era in the history of the latter institution. There is much work ahead for Supt. Littleton.

Supt. Coffey, of the Peoria (Ills.) Gas Light Company, has returned from his tour of Europe, vastly improved in health—information that will delight his numerous friends.

There promises to be an exodus of Western men to New York. The writer predicts a larger

number of Western men will attend the American convention this year than appeared at any meeting heretofore held in the East.

The Market for Gas Securities.

The city market for gas shares remains in a state similar to that which we have been obliged to chronicle for the past two or three months. We hold, however, to the opinion that a lively upward turn will shortly take place in Consolidated. Other city gas shares are weak and lower, Equitable having suffered a loss of 5 points in the fortnight. Brooklyn shares maintain their recent values fairly well, and we incline to the view that Nassau and old Brooklyn present good opportunities for investment purchases. The Chicago situation, as will be noted in other pages of this issue, is decidedly mixed just now, but Trust certificates at quoted prices look very tempting. The Baltimore war of rates still keeps money out of the pockets of holders of Monumental City gas shares, but shrewd observers predict that the end of the knifing operation draws near. Eastern gas shares are on the up-track—in fact it is hard to say what figures would really tempt holders to part with their pet securities. The Montreal Gas Company is now paying the regular semi-annual dividend of 6 per cent. The annual meeting of the Consumers Gas Company, of Toronto, is to be held on the 31st inst.

Gas Stocks.

Quotations by Geo. W. Close, Broker and Dealer in Gas Stocks.

16 WALL ST., NEW YORK CITY.
OCTOBER 17.

All communications will receive particular attention.
The following quotations are based on the par value of \$100 per share.

	Capital.	Par.	Bid	Asked
Consolidated.....	\$35,430,000	100	71	—
Central.....	440,000	50	30	—
“ Scrip.....	220,000	—	47	57
Equitable.....	2,000,000	100	110	115
“ Bonds.....	1,000,000	—	113	115
Harlem, Bonds.....	170,000	—	—	—
Metropolitan, Bonds....	658,000	—	110	113
Mutual.....	3,500,000	100	88	91
“ Bonds.....	1,500,000	1000	101	—
Municipal, Bonds.....	750,000	—	—	—
Northern.....	125,000	50	30	—
“ Scrip.....	108,000	—	—	—
Yonkers.....	—	50	—	80
Richmond Co., S. I.	300,000	50	50	—
“ Bonds.....	12,000	—	—	—
Gas Co's of Brooklyn.				
Brooklyn.....	2,000,000	25	—	102
Citizens.....	1,200,000	20	50	—
“ S. F. Bonds....	320,000	1000	—	103
Fulton Municipal.....	3,000,000	100	125	128
“ Bonds....	300,000	—	—	106
Peoples.....	1,000,000	10	57	60
“ Bonds (5's).....	368,000	—	97	—
“ “ (6's).....	94,000	—	100	—
Metropolitan.....	1,000,000	100	75	78
Nassau.....	1,000,000	25	—	100
“ Ctf's.....	700,000	1000	95	100
Williamsburgh.....	1,000,000	50	112	115
“ Bonds... ..	1,000,000	—	111	—
Out of Town Gas Companies.				
Boston (Mass.) Gas Co.	2,500,000	500	220	—
Buffalo Mutual, N. Y....	750,000	100	90	95
“ Bonds... ..	200,000	1000	95	100
Citizens, Newark.....	1,000,000	50	140	145
“ “ Bonds.	45,000	—	—	—
Chicago Gas Trust.....	25,000,000	100	34	36
Cincinnati G. & C. Co..	6,000,000	100	182½	185

Advertisers Index.

GAS ENGINEERS.		Page
Jos. R. Thomas, New York City	248
Wm. Henry White, New York City	248
Wm. Mooney, New York City	248
William Gardner, Pittsburgh, Pa.	248
GAS WORKS APPARATUS AND CONSTRUCTION.		
James R. Floyd, New York City	251
T. F. Rowland, Greenpoint, L. I.	251
Deily & Fowler, Phila., Pa.	251
Kerr Murray Mfg. Co., Fort Wayne, Ind.	250
Stacey Mfg. Co., Cincinnati, Ohio	251
Bartlett, Hayward & Co., Baltimore, Md.	241
Morris, Tasker & Co., Limited, Phila., Pa.	250
Davis & Farnum Mfg. Co., Waltham, Mass.	208
R. D. Wood & Co., Phila., Pa.	250
Bouton Foundry Co., Chicago, Ills.	251
Smith & Sayre Manufacturing Co., New York City	251
PROCESSES.		
National Gas Light and Fuel Co., Chicago, Ills.	242
American Gas Improvement Co., Pittsburgh, Pa.	240
GAS AND WATER PIPES.		
Gloucester Iron Works, Phila., Pa.	248
Mellert Foundry and Machine Co., Reading, Pa. (John Fox, Selling Agent, N. Y.)	248
Cincinnati and Newport Iron and Pipe Co., Newport, Ky.	248
Ohio Pipe Co., Columbus, Ohio	248
Pancoast & Rogers, New York City	248
M. J. Drummond, New York City	248
Wells Rustless Iron Co., New York City	248
R. D. Wood & Co., Phila., Pa.	250
GAS ENGINES.		
Schleicher, Schumm & Co., Phila., Pa.	256
Clerk Gas Engine Co., Phila., Pa.	243
RETORTS AND FIRE BRICK.		
J. H. Gautier & Co., Jersey City, N. J.	246
B. Kreisler & Sons, New York City	246
Adam Weber, New York City	246
Laclede Fire Brick Works, St. Louis, Mo.	246
Brooklyn Retort and Fire Brick Works, Brooklyn, N. Y.	246
Borgner & O'Brien, Phila., Pa.	246
James Gardner, Jr., Pittsburgh, Pa.	246
Henry Maurer & Son, New York City	246
Chicago Retort and Fire Brick Works, Chicago, Ills.	243
Baltimore Retort and Fire Brick Co., Baltimore	246
Oakhill Gas Retort and Fire Brick Co., St. Louis, Mo.	246
Evens & Howard, St. Louis, Mo.	247
Cincinnati Gas Retort and Fire Brick Works, Cincinnati, O.	247
Emil Lenz, New York City	247
SCRUBBERS AND CONDENSERS.		
G. Shepard Page, New York City	249
R. D. Wood & Co., Phila., Pa.	250
REGENERATIVE FURNACES.		
Bartlett, Hayward & Co., Baltimore, Md.	241
Fred. Bredel, New York City	247
GAS GOVERNORS.		
T. C. Hopper, Phila., Pa.	244
Connelly & Co., New York City	243
CEMENTS.		
C. L. Gerould & Co., Brooklyn, N. Y.	246
GAS ENRICHERS.		
Standard Oil Co., Cleveland, Ohio	252
GAS METERS.		
Harris, Griffin & Co., Phila., Pa.	254
American Meter Co., New York and Philadelphia	255
The Goodwin Gas Stove and Meter Co., Philadelphia, Pa.	255
Helme & McIlhenny, Phila., Pa.	255
D. McDonald & Co., Albany, N. Y.	255
Nathaniel Tufts, Boston, Mass.	254
EXHAUSTERS.		
P. H. & F. M. Roots, Connersville, Ind.	242
Smith & Sayre Manufacturing Co., New York City	251
Wilbraham Bros., Philadelphia, Pa.	243
Connelly & Co., New York City	243
GAS COALS.		
Penn Gas Coal Co., Phila., Pa.	253
Perkins & Co., New York City	252
Newburgh Orrel Coal Co., Baltimore Md.	253
Despard Coal Co., Baltimore, Md.	253
Chesapeake and Ohio R.R. Coal Agency, N. Y. City	253
Westmoreland Coal Company, Phila., Pa.	253
Monongahela & Peters Creek Gas Coal Co., Pittsburgh, Pa.	253
CANNEL COALS.		
Perkins & Co., New York City	252
J. & W. Wood, New York City	252

VALVES.		
Ludlow Valve Manufacturing Co., Troy, N. Y.	244
John McLean, New York City	241
Chapman Valve Manufacturing Co., Boston, Mass.	241
R. D. Wood & Co., Phila., Pa.	250
The Combination Gas Machine Co., Detroit, Mich.	239
ENGINES AND BOILERS.		
Jarvis Engineering Co., Boston, Mass.	243
PURIFYING MATERIAL.		
S. H. Douglas, Ann Arbor, Mich.	247
Connelly & Co., New York City	243
GAS LAMPS.		
The Siemens-Lungren Co., Philadelphia, Pa.	249
G. Shepard Page, New York City	242
Albo-Carbon Light Co., Newark, N. J.	240
Standard Gas Lamp Co., Phila., Pa.	247
PURIFIER SCREENS.		
John Cabot, New York City	230
Geo. A. Mills, Baltimore, Md.	241
GAS STOVES.		
American Meter Co., New York and Philadelphia	245
The Goodwin Gas Stove and Meter Co., Phila. Pa.	224
The Combustion Gas Machine Co., Detroit, Mich.	239
Dinsmore Manufacturing Co., Boston, Mass.	239
STREET LAMPS.		
J. G. Muer, Morrisania, New York City	230
Bartlett Street Lamp Mfg Co., New York City	247
BURNERS.		
C. A. Gefroerer, Phila., Pa.	252
STEAM BLOWER FOR BURNING BREESE.		
H. E. Parson, New York City	244
GASHOLDER TANKS.		
W. C. Whyte, New York City	250
GAS FIXTURES.		
Mitchell, Vance & Co., New York City	244
COKE CRUSHER.		
C. M. Keller, Columbus, Ind.	253
ELECTRICAL APPARATUS.		
Waterhouse Electric & Manufg Co., Hartford, Conn.	240
BOOKS, ETC.		
English Journal of Gas Lighting	230
Gas as a Source of Light, Heat and Power	244
Goodwin's Directory of Gas Light Companies	252
King's Treatise	254
Scientific Books	254
Management of Small Gas Works	248
Newbigging's Gas Manager's Handbook	254
Gas vs. Electricity	247
Practical Electric Lighting	243
Electric Light Primer	243

Position Wanted,

By a young man (22)

As Superintendent of a Gas Works.

Understands thoroughly the manufacture and distribution of coal and water gas, and is also a graduate chemist of the School of Mines, N. Y. Address R. E. SLADE, Yonkers, N. Y.

ENGLISH

"Journal of Gas Lighting."

Issued weekly. New volume commences Jan. 1, 1887. Price, \$7 per annum. Subscriptions taken by

CHARLES NETTLETON, Agent for U. S., No. 115 BROADWAY, N. Y. CITY.



CONE GAS STOVE

FOR HEATING rooms of any size. Perfect combustion. No injurious odors to be carried away by a chimney. Warranted odorless, or the purchase money refunded. DINSMORE MFG. CO., 28 Kneeland Street, Boston, Mass. Send for Catalogue.

THE GLOBE STREET LAMP.



MINER'S PATENT STREET LAMPS.

Are adapted for use of Streets, Parks, Depots, Ferries, & Private Grounds. WITH POSTS OR BRACKETS.

Jacob G. Miner,

No. 823 Eagle Ave., New York, N. Y.

GAS STOVES

Of Every Description, for Heating, Cooking, Laboratory, and Mechanical Purposes.

Weber Straight-Way Valves

FOR GAS, STEAM, AND WATER.

Catalogues on Application.

Correspondence Solicited.

THE COMBINATION GAS MACHINE CO.,
Detroit, Mich. Windsor, Ont.

163 Maiden Lane, N. Y. City.

87 Dearborn Street, Chicago, Ill.

CHURCH'S REVERSIBLE TRAY

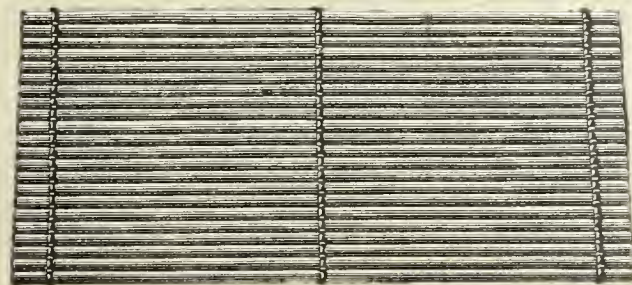

For Purifiers and Scrubbers.

OVAL OR RECTANGULAR SLATS.

FOR LIME OR IRON SPONGE.

MALLEABLE IRON CROSS BARS.

Strongest! Most Durable!
Most Easily Repaired!

MANUFACTURED BY

JOHN CABOT,

306 to 310 Eleventh Ave., N. Y. City.

Patented July 9, 1878, and Feb. 5, 1884.

Used by the principal Companies in every State of the Union. Price List on application.

ILLUMINATING GAS FROM NATURAL GAS.**THE AMERICAN GAS IMPROVEMENT CO., Limited,** 95 Fifth Avenue, Pittsburgh, Pa.

Erect Apparatus for the treatment of Natural Gas for an Illuminant under the

McKAY-CRITCHLOW SYSTEM.

Satisfaction in Economy and Quality Guaranteed.

Apparatus adapted to the manufacture of Water Gas, without any change whatever, should it be desirable to do so on account of Natural Gas playing out. Apparatus erected or Licenses sold at the following Works.

Pittsburgh Gas Works, J. H. McElroy, Engr.
 Allegheny Gas Works, Robt. Young, Engr.
 East End Gas Works, W. H. Denniston, Engr.
 West Pittsburgh Gas Works, E. C. Critchlow, Supt.
 Beaver Falls Gas Works, H. F. Dillon, Supt.
 Titusville Gas Works, E. T. Roberts, Treas.
 Salamanca, N. Y.
 Jamestown, N. Y.
 Meadville, Pa., Wm. Reynolds, Prest.

Warren, Pa., S. S. Franklin, Supt.
 Franklin, Pa., C. W. Gilfillan, Prest.
 Oil City, Pa.
 Erie Gas Co., Erie, Pa., W. H. Hill, Engr.
 Greensburg, Pa., Jas. C. Clarke, Prest.
 Sewickley, Pa., J. W. Forbes, Supt.
 Bellaire, Ohio, John Ferguson, Supt.
 New Castle, Pa., D. T. Flick, Supt.
 Corry, Pa.

Sharon, Pa., S. Perkins, Prest.
 Fort Scott, Kansas, L. K. Scofield, Owner.
 Fostoria, Ohio, Jos. Gwynn, Supt.
 Emporia, Kansas.
 Tiffin, Ohio.
 Wellsville, Ohio.
 Brownsville, Pa.

THE ALBO-CARBON LIGHT.

THIS SYSTEM HAS SHOWN ITSELF IN THOUSANDS OF CASES—IN HALLS, CHURCHES, PICTURE GALLERIES, CONCERT HALLS, RESTAURANTS, BANKS, CLUBS, STORES, OFFICES, and PRIVATE RESIDENCES—TO BE THE

Best Adapted and Most Successful Method of Gas Lighting Ever Offered.

The SOFTNESS AND PURITY OF THE LIGHT make it most desirable for Office and Household Uses. Its BRILLIANCY and POWER render it unrivaled for lighting Halls, Churches, etc. Its ECONOMY secures for it general favor wherever used.

NOTICE.—Suits are pending in the United States Circuit Courts in Illinois and Pennsylvania against various parties for infringement of our Letters Patent No. 247,925, dated October 4, 1881, and No. 333,862, dated January 5, 1886. The first of these suits has come up for hearing, and an injunction has been granted therein. The second of said suits has not yet been reached for hearing. All persons are cautioned against manufacturing, selling, or using any apparatus or material which infringes our patents. We intend to prosecute all parties infringing patents owned by us.

ALBO-CARBON LIGHT CO. (Sole Manufacturers for the United States) Main Office, Newark, N. J.**The Waterhouse System of Arc & Incandescent Lighting**

Is invariably appreciated by electricians. The light produced is remarkably steady, and the regulation wonderful. The efficiency of the dynamos (closed circuit) is a large percentage in our favor as compared with that of the open circuit machines, so that we show GREAT ECONOMY.

Investigation Invited by Electrical Experts and Others.

SEND FOR CATALOGUE.

THE WATERHOUSE ELECTRIC AND MFG. COMPANY,
Factory, Colt's West Armory. Hartford, Conn.**To All Whom It May Concern!**

The SIEMENS-LUNGREN COMPANY hereby warns the public against the use of various infringing Regenerative Gas Lamps which are offered for sale. This Company has heretofore delayed bringing suit to enjoin the manufacture or importation of such infringing lamps, solely because of the practical worthlessness of the infringing devices; and although, in each instance, they infringe some one or more of the various patents owned or controlled by this Company, they have fallen into disuse sooner than any suit could be brought to a hearing. As, however, the introduction of these infringing lamps has tended to discredit the practicability of our Company's system of regenerative gas lighting, we have instructed our Attorneys, Messrs. Geo. Harding, C. S. Whitman, and Silas W. Pettit, to give notice that legal proceedings will in future be taken against all such infringers.

THE SIEMENS-LUNGREN CO., 21st St. & Washington Av., Phila., Pa.

BARTLETT, HAYWARD & CO.

Baltimore, Md.

Munich Regenerative Furnace, System Drs. Schilling & Bunte.

Greatest durability; minimum of attention; complete distillation in 3½ hours; 10 to 13 pounds of coke to hundred-weight of coal; no clinker; no carbonic oxide in regenerative flues.

TWO AND THREE-LIFT TELESCOPIC GASHOLDERS,

With Wrought Iron Tanks, constructed above ground, of any magnitude.

Condensers, Scrubbers, Purifiers, Bench Castings, Roofs, Boilers, Etc.

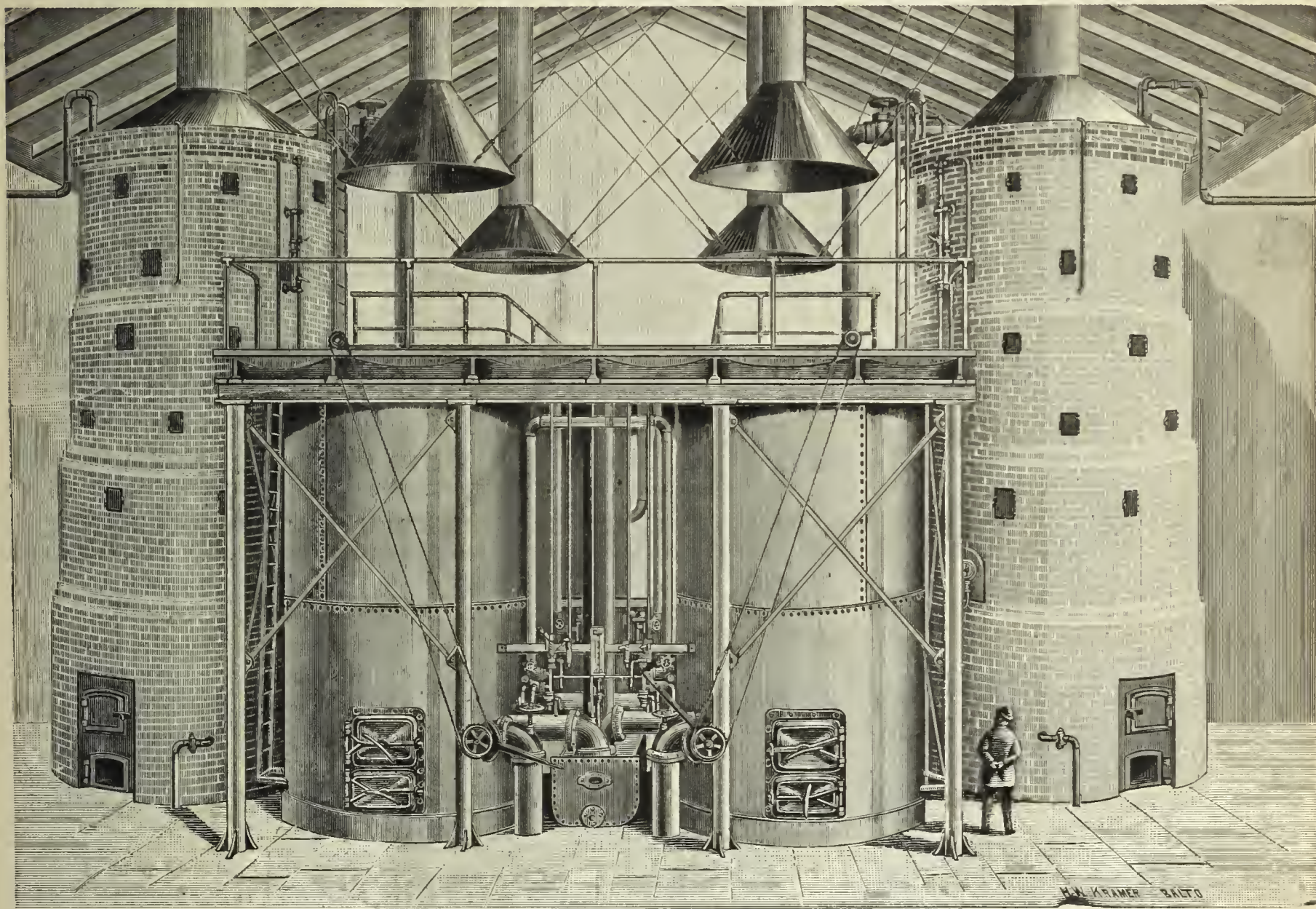

The Wilkinson Water Gas Process.

Introducing the Munich Regenerative Furnace for Coal Gas, we find on the part of many Gas Companies the desire to combine to a greater or less extent an efficient system of making high candle power Water Gas; and with a view of enabling this to be done WITHOUT EXCESSIVE CHARGES FOR PATENT RIGHTS, ETC., we have acquired, by purchase, the exclusive right to construct all the Water Gas Apparatus under the valuable "Wilkinson" Patents.

The results obtained by this Process are far better than those obtained by any other apparatus, especially where an illuminating gas of high candle power or a fuel gas of intense temperature is required.

The Process is uninterrupted, making gas of uniform quality and quantity. Its greatest advantages are maximum production with minimum material and labor, combined with great durability of apparatus.

The Process is in successful operation at the works of the N. Y. Mutual Gas Company, New York; Consolidated Gas Company, Baltimore, Md.; the Hudson County Gas Light Company, of Hoboken, N. J.; and at Rye, N. Y.

We shall be glad to give further detailed information upon application.

Sole Agents for the Celebrated Hazelton Boiler.

BARTLETT, HAYWARD & CO.

EXHAUSTERS.

EXHAUSTERS.

PROCESSES.

NATIONAL GAS LIGHT AND FUEL COMPANY,

No. 218 La Salle Street, Chicago.

THE SPRINGER SYSTEM

OF

Fuel and Illuminating Water Gas Works.

REFERENCES.

People's Gas Light and Coke Co.....	Chicago, Ill.	Mankato Gas Light Co.....	Mankato, Minn.
Elgin National Watch Co.....	Elgin, Ill.	Minneapolis Gas Light and Coke Co.....	Minneapolis, Minn.
C. R. I. & P. R. R. Shops.....	Chicago, Ill.	Lima Gas Light Co.....	Lima, Ohio.
Decatur Gas Light and Coke Co.....	Decatur, Ill.	Bellevue Water and Fuel Gas Light Co.....	{ Bellevue, Campbell County, Ky.
Niles Gas Light Co.....	Niles, Mich.	Bucyrus Gas Light and Fuel Co.....	Bucyrus, Ohio.
Newton Illuminating Co.....	Newton, Kansas.	Morris Gas Co.....	Morris, Ill.
Wellington Light and Heat Co.....	Wellington, Kansas.	Los Angeles Gas Co.....	Los Angeles, Cal.
Chippewa Falls Gas Light Co.....	Chippewa Falls, Wis.	San Diego Gas Fuel and Electric Lt. Co.....	San Diego, Cal.
Elkhart Gas Light and Coke Co.....	Elkhart, Ind.	Jackson National Gas Co.....	Jackson, Mich.
Madison City Gas Light Co.....	Madison, Wis.	Sioux Falls Gas Co.....	Sioux Falls, Dak.
South Bend Gas Light Co.....	South Bend, Ind.	Dakota Gas and Fuel Co.....	Grand Forks, Dak.
Sheboygan National Gas Co.....	Sheboygan, Wis.	St. Johns Mutual Gas Co.....	St. Johns, Mich.
Salina Gas Light Co.....	Salina, Kansas.	Stillwater Gas Light Co.....	Stillwater, Minn.
The Rathbun Co.....	Deseronto, Prov. Ont.	St. Paul Gas Light Co.....	St. Paul, Minn.
Jefferson City Gas Light Co.....	Jefferson City, Mo.		

GUARANTEED ESTIMATES of Cost of Gas Furnished on Application.

ROOTS' NEW GAS EXHAUSTER.

St. Louis, Mo., }
March 21, 1887. }

Messrs. P. H. & F. M. Roots, Connersville, Ind.:
Dear Sirs—In 1872 one of your No. 5 Exhausters was placed in these works, and worked satisfactorily. In March, 1885, it was replaced by one of your No. 6 Exhausters. The latter has been in almost constant use the past two years, has worked up to all my expectations, and is to-day in apparently as good condition as when first set up. It has not cost one cent for repairs in all that time. I have also

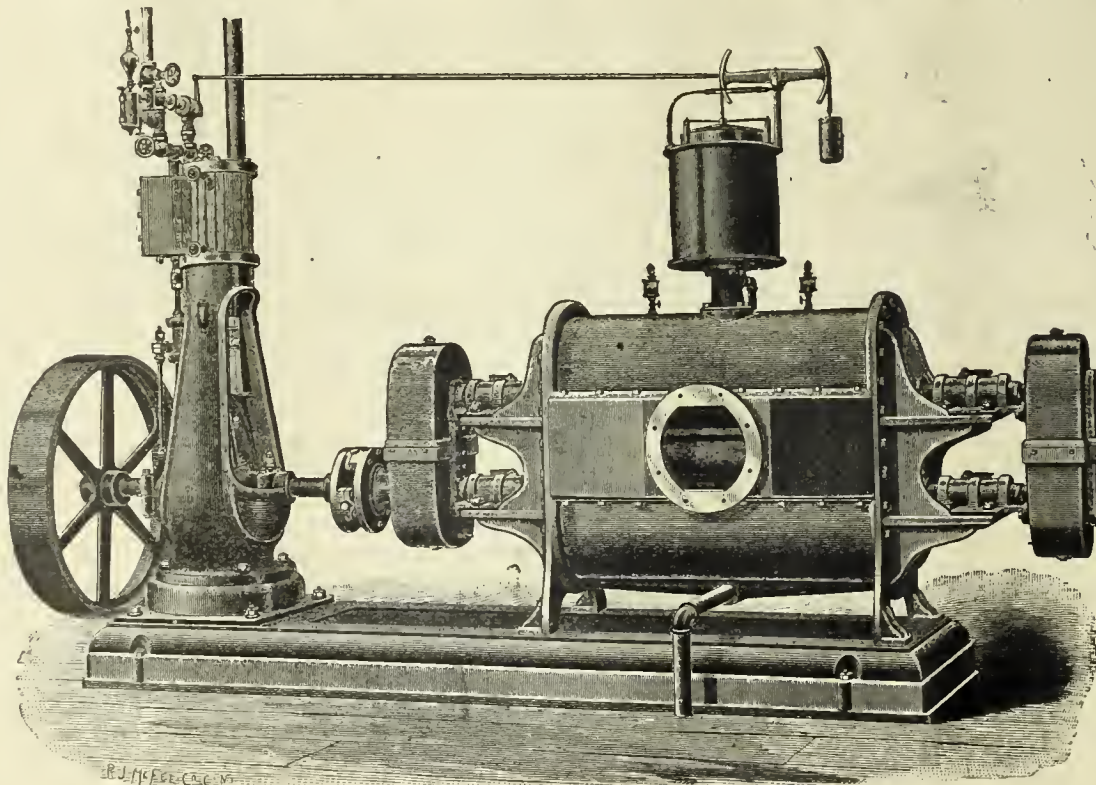

had one of your No. 1 Exhausters, with Engine on same bed-plate, fitted with your valves and Huntoon Governor, placed in a small works under my control, and in its operation it seems as near perfection as I ever expect an Exhauster to become. Without in the least disparaging Exhausters of other makes, I may say that your Exhauster may be safely recommended as unsurpassed by any other, to those requiring such machines.

Yours respectfully,
FREDERIC EGNER,
Eng. and Supt.

CONSTRUCTED ON ENTIRELY NEW PRINCIPLES.

THE ONLY EXHAUSTER MADE IN WHICH

The Internal Operating Parts Consist of Only Two Pieces, Each Cast Entire in One Piece.

Send for Descriptive Catalogue and Price List.

P. H. & F. M. ROOTS, Patentees and Manufacturers, CONNERSVILLE, IND.

S. S. TOWNSEND, Gen. Agt., 22 Cortlandt St., N. Y. COOKE & CO., Selling Agts., 22 Cortlandt St., N. Y.

CONNELLY & CO., LTD.,

SOLE MANUFACTURERS OF THEIR PATENTED SPECIALTIES.

"IRON SPONGE." Saves money, saves labor, and is the most efficient purifying agent ever offered as a substitute for lime. Now used *in every State in the Union*, and purifying daily over *twenty-five million cubic feet*. Should be used in every gas works. Its own saving will pay for it many times over.

AUTOMATIC GOVERNOR. Has been on the market but *two years*, and in that time has been introduced *more generally* than any invention ever designed for use in gas works. Over *one hundred* of them now in use. Sensitive; reliable; perfectly automatic; reduces leakage; satisfies consumers, and gives great relief to the Manager. No gas works is *complete* without one of these machines.

STEAM JET EXHAUSTER. Designed particularly for small works. Combines Exhaust Tube, Steam Governor, Gas Compensator, and Bye-Pass Valves in the most compact form possible; occupies but little space; uses very little steam; operated by ordinary workmen; saves formation of carbon in retorts; increases yield 10 to 15 per cent. Specially adapted for *mixing air* with oil gas. *No works* too small to use them profitably.

Prices given on all our specialties *delivered at any point in the United States*. Correspondence solicited.

CONNELLY & CO., LTD., No. 177 Broadway, New York City.

WILBRAHAM GAS EXHAUSTER

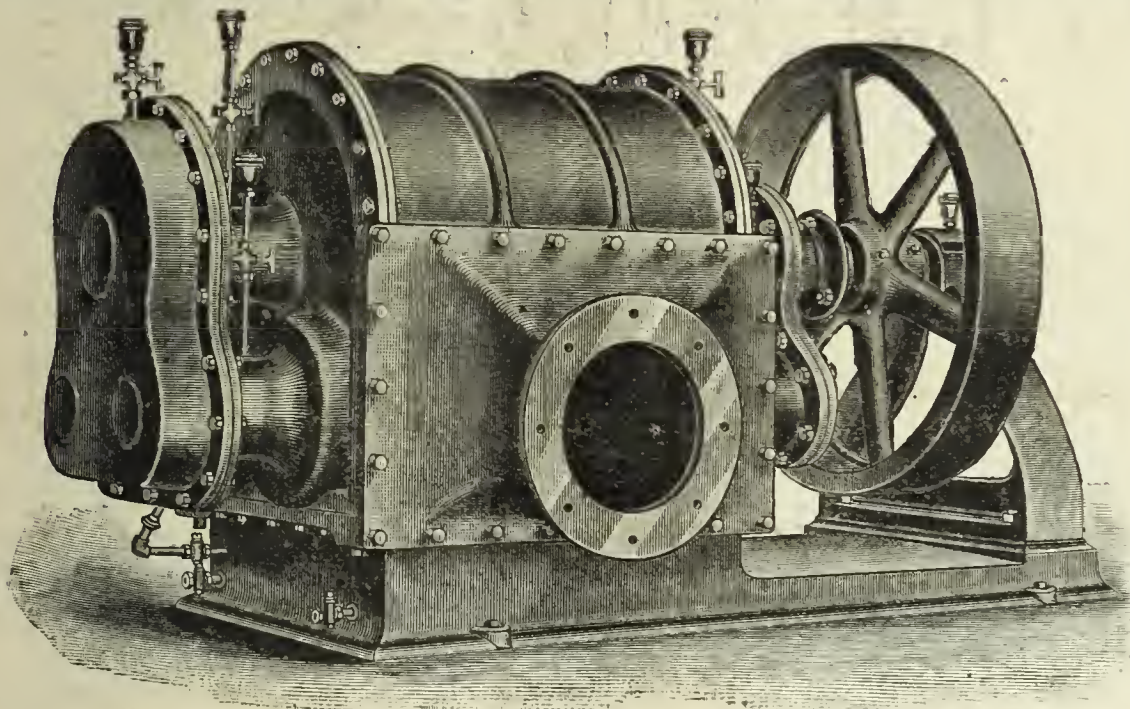

WILBRAHAM BROS.,
PHILADELPHIA, PA.

JARVIS ENGINEERING CO.,

61 Oliver St., Boston, Mass.

CONTRACTORS FOR ERECTING

COMPLETE STEAM OUTFITS FOR ELECTRIC LIGHTING STATIONS.

Steel Boilers set with Jarvis Pat. Boiler Setting

To burn **COKE SCREENINGS** for Fuel.

ARMINGTON & SIMS CO. ENGINES,

Belting direct to Dynamos, without using Shafting.

SEND FOR CIRCULARS.

REFERENCES — Charlestown Gas & Electric Light Co., Charlestown, Mass.; Schenectady Gas & Electric Light Co., Schenectady N. Y.; Brookline Gas Co., Brookline, Mass.

Practical Electric Lighting,

By A. BROMLEY HOLMES, A.M.I.C.E.

With 87 Illustrations. Third Edition. Price, \$1.00.

Electric Light Primer.

By CHARLES L. LEVEY.

A simple and comprehensive Digest of all the most important facts connected with the running of the Dynamo and Electric Lights, with Precautions for Safety, etc.

Price, 50 cents.

A. M. CALLENDER & CO., 42 Pine St., N.Y.

THE CLERK GAS ENGINE CO.,

Main Office, 1012, 1014, 1016, 1018 Filbert St., Philadelphia, Pa.

WM. W. GOODWIN, Prest.

E. STEIN, Sec.

S. LEWIS JONES, Asst. Sec.

A. J. DOTY, Supt.

The utility and convenience of the Gas Engine being no longer an open question, it only remains now for intending purchasers to select the BEST. We claim for the CLERK GAS ENGINE that it is equal to any other manufactured as regards steadiness in running, simplicity, and ease of keeping in repair, and that it gives the greatest amount of power for the least money (both in first cost and expense of running) of any engine made. In support of this claim we refer to the test of the Gas Engines made under the direction of the American Institute of New York, in December, 1885, and heretofore published in these columns. These engines are especially adapted for continuous running under heavy loads, and we can refer to Engines which have run 22 hours a day for months at a time.

Made in Sizes of 5, 10, 15, 20, and 25 Horse Power. All Engines Guaranteed for One Year.



CHAPMAN VALVE MANUFACTURING CO., LUDLOW VALVE MFG. CO.

MANUFACTURERS OF

Valves and Gates for Gas, Ammonia, Water, Etc.

Also, Gate Fire Hydrants With and Without Independent Nozzle Valve. All Work Guaranteed.

WORKS & GEN'L OFFICE:
Indian Orchard, Mass.

TREASURER'S OFFICE:
72 Kilby & 112 Milk Sts, Boston, Mass.



OFFICE AND WORKS,

938 to 954 River Street and 67 to 83 Vail Av
TROY, N. Y.

How to Reduce Leakage to Its Minimum.

USE

HOPPER'S AUTOMATIC DIFFERENTIAL GAS GOVERNOR.

Needs No Attention. Simple, Reliable, Perfectly Automatic.
"Nearly Thirty in Use."

BYE-PASSES, DRY CENTER VALVES, PRESSURE REGISTERS. Also, GOVERNORS FOR STREET MAINS, *NOT DIFFERENTIAL*, and for EXHAUSTERS, GAS ENGINES, etc.

Our new Bye-Pass is threefold in its action—passes gas through, or bye-passes, or shuts off entirely. Correspondence solicited; information given. Send for circulars and testimonials.

T. C. HOPPER & CO., - - No. 2227 Wood Street, Philadelphia, Pa.

MILLS' REVERSIBLE LIME TRAY,

AND

WOODWORK

Of Every Description

NEEDED BY GAS WORKS.

SEND FOR CIRCULAR AND PRICE LIST TO

GEORGE A. MILLS,

Canton Av. & President St., Baltimore, Md.

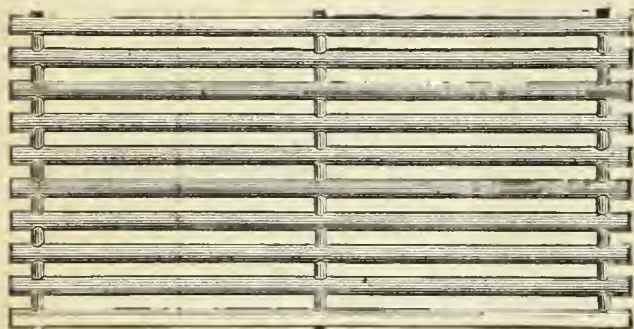

Parson's Steam Blower,

FOR IMPROVING BAD DRAUGHT IN BOILERS, AND FOR BURNING BREEZE OR OTHER WASTE MATERIAL.

PARSON'S TAR BURNER.

FOR UTILIZING COAL TAR AS FUEL.

PARSON'S AIR JET TUBE CLEANER,

FOR CLEANING BOILER TUBES.

These devices are all first-class. They will be sent to any responsible party for trial. No sale unless satisfactory. Manufactured by the WATERTOWN STEAM BLOWER COMPANY.

H. E. PARSON. Supt., 33 & 35 Liberty St., N. Y.

Hydraulic Main Dip Regulators, also Check Valves, Foot Valves, Yard-wash and Fire Hydrants. Send for Circulars.

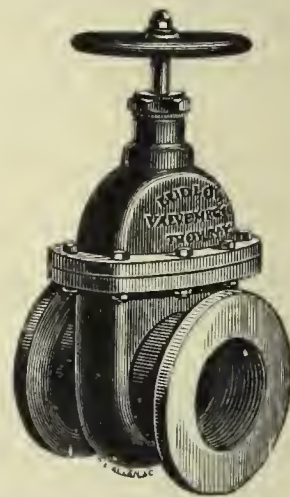

Valves.—Double and Single Gate, 1/2 in. to 48 in., outside and inside Screws. Indicator, etc., for Gas, Water, Steam, and Oil. Send for Circulars.

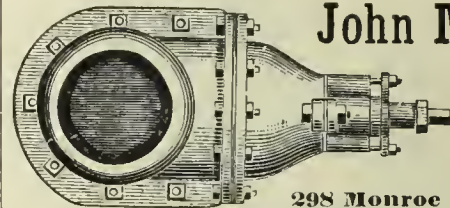

John McLean

Manufacturer of

GAS VALVES.

298 Monroe Street, N. Y.

MITCHELL VANCE & CO.,

MANUFACTURERS OF

Chandeliers

and every description of

GAS FIXTURES.

Also manufacturers of Fine Gilt Bronzes and Marble Clocks, warranted best time-keepers. Mantel Ornaments, etc.

Salesrooms, 836 Broadway, N. Y.

Special Designs furnished for Gas Fixtures for Churches, Public Halls, Lodges, etc.

GAS AS A SOURCE OF LIGHT, HEAT, AND POWER.

By C. J. R. HUMPHREYS

A Pamphlet of twenty-nine pages, treating of the use of Gas as a source of Light, Heat, and Power.

DESIGNED FOR DISTRIBUTION BY GAS COMPANIES AMONG THEIR CUSTOMERS AND OTHERS.

Price, 10 cents each, \$5 per 100, \$50 per 1,000.

Gas Companies can have their own imprint placed on cover without extra charge. All orders to be sent to

A. M. CALLENDER & CO.,

No. 42 Pine Street, N. Y. City.

GAS STOVES.

GAS STOVES.

GAS STOVES.

THE AMERICAN METER CO.,

MANUFACTURERS OF

GAS COOKING AND HEATING STOVES.

Gas
Heating
Stoves
in
all
Sizes
for
Parlors,
Chambers
and
Offices.



Verity's and Wilson's Patent Gas Fires For Open Fireplaces.

Gas
Cooking
Stoves
and
Ranges
in
all
Sizes
for
Family
and
Hotel
Use.



Catalogues and Price Lists on Application.

Catalogues and Price Lists on Application.

MANUFACTORIES,

508 to 514 West Twenty-second St., N. Y.

Arch and Twenty-second St., Phila.

Nos. 244 & 246 North Wells Street, Chicago, Ill.

AGENCIES,

No. 177 Elm Street, Cincinnati, Ohio.

No. 222 Sutter Street, San Francisco Cal

No. 810 North Second Street, St. Louis, Mo.

GAS STOVE SHOW ROOMS, No. 223 Sixth Avenue, New York City.

RETORTS AND FIRE BRICK.

J. H. GAUTIER & CO.,CORNER OF
GREENE AND ESSEX STREETS,
JERSEY CITY, N. J.

MANUFACTURERS OF

**Clay Gas Retorts,
Gas House Tiles,
Fire Bricks, Etc. Etc.**Ground Clay, Fire Brick and
Fire Sand in Barrels,J. H. GAUTIER.
C. E. GREGORY.T. B. GAUTIER.
C. E. GAUTIER.**BROOKLYN****Clay Retort & Fire Brick Works,**
(EDWARD D. WHITE & CO.)Manufacturers of Clay Retorts, Fire Brick,
Gas House and other Tile.VAN DYKE, ELIZABETH, RICHARDS & PARTITION STS.
Office, 88 Van Dyke St., Brooklyn, N. Y.

RETORTS AND FIRE BRICK.

LACLEDE FIRE BRICK MFG. CO.,

MANUFACTURERS OF

Fire Brick, Gas Retorts,

AND

ST. LOUIS STANDARD SEWER PIPE.Blast Furnace and Cupola Linings, every description of Fire
Clay Material, Fire Clay Flue Linings, Chimney Tops
Dry Milled and Crude Fire Clays, etc.

OFFICE AND DEPOT

901, 903, and 905 Pine Street,
ST. LOUIS, MO.

ESTABLISHED IN 1845.

B. KREISCHER & SONS,

OFFICE FOOT OF HOUSTON ST., E. R., N. Y.

Gas Retorts,**TILES, FIRE BRICK.**

AND EVERYTHING IN THE FIRE CLAY LINE.

RETORTS AND FIRE BRICK.

MANHATTAN

FIRE BRICK & ENAMELLED CLAY

RETORT WORKS.**ADAM WEBER.****CLAY GAS RETORTS**

AND RETORT SETTINGS

FIRE BRICKS, TILES, ETC.,

Office and Works, 15th Street and Avenue C., N. Y.

Works,
LOCKPORT STATION, PA.

—ESTABLISHED 1864.—

JAMES GARDNER, JR.,Office, Rooms 19 & 20, Lewis Block,
PITTSBURGH, PA., P. O. Box 373.

Successor to WILLIAM GARDNER & SON.

Fire Clay Goods for Gas Works.

CHAS. H. SPRAGUE & SON, No. 70 KILBY STREET, BOSTON, MASS., Agents for the New England States.

OFFICE, 418 to 422 East 23d St., New York.

ESTABLISHED 1856.

WORKS, PERTH AMBOY, NEW JERSEY.

HENRY MAURER & SON,
Excelsior Fire Brick & Clay Retort Works
CLAY GAS RETORTS, BENCH SETTINGS, FIRE BRICK, TILES, ETC.**CHICAGO****Retort & Fire Brick Works,**OFFICE AND FACTORY,
Clark, Forty-Fifth, and La Salle Streets,
CHICAGO, ILL.

GEORGE C. HICKS, PRES. PAUL P. AUSTIN, SEC. & TREAS.

STANDARD

Clay Retorts and Settings.**BLOCKS & TILES**

Of every Shape and Size to Order.

Standard Fire Bricks.**GEROULD'S IMPROVED RETORT CEMENT.**A Cement for patching retorts, putting on mouthpieces, and
making up all bench-work joints. This Cement is mixed ready
for use. Economic and thorough in its work. Fully warranted
to stick. For recommendations and price list address**C. L. GEROULD & CO.,**

5 & 7 Skillman St., Brooklyn, N. Y.

Western Agent, H. T. GEROULD, Mendota, Ill.

OAKHILL**GAS RETORT & FIRE BRICK**

Works.

Proprietors,

PARKER-RUSSELL MINING & MFG. CO.

City Office, 711 Pine Street,

ST. LOUIS, MO.

Our immense establishment is now employed almost entirely in
the manufacture of**MATERIALS FOR GAS COMPANIES.**We have studied and perfected three important points. Our re-
torts are made to stand changes of temperature, the strongest
heats of the furnace, and the abrasion of feeding and emptying.
Our customers are in almost every State of the Union, to all of
whom we refer

THOS. SMITH, Prest. AUGUST LAMBLA, Vice-Prest. & Sup

BALTIMORE**RETORT & FIRE BRICK CO.**

MANUFACTORY AT

LOCUST POINT, BALTIMORE, MD.

Connection with the City by Telephone.

**Clay Retorts, Blocks & Tiles,
FIRE BRICK, FIRE CLAY,
AND FIRE CEMENT.**Red and Buff Ornamental Tiles and Chim-
ney Tops. Drain and Sewer Pipe (from
2 to 30 inches). Baker Oven Tiles
12x12x2 and 10x10x2.**WALDO BROS., 88 WATER ST., BOSTON, MASS**

Sole Agents the New England States.

EVENS & HOWARD,

916 Market St., St. Louis. Mo.
Works, Howard Station, Mo. Pacific R.R.

Fire Brick, Gas Retorts

AND

RETORT SETTINGS.

Sewer Pipe, 3 to 24 in. diameter.

Glass Pot Clay, Ground Fire Clay, in barrels and in bulk. All kinds of Fire Clay Goods.

Cincinnati Gas Retort & Fire Brick Works.

—ESTABLISHED 1872.—

CHAS. TAYLOR,

MANUFACTURER OF

Gas Retorts, Fire Brick, and Tile.

Blast Furnace Linings, Cupola Blocks, Boiler Tiles, Grate Settings, and Stove Linings. Fire Cement, Fire Clay, Fire Sand, and all other Fire Clay Goods.

Branch Works, New Cumberland, W. Va.

GENERAL OFFICE AND WORKS,

Burns St., Cincinnati, Ohio.

EMIL LENZ,

2 & 4 Stone St., N. Y. City.

CLAY GAS RETORTS

(ENAMELED.)

Fire Brick, Blocks & Tiles.

FIRE CEMENT, RETORT ENAMEL, RETORT CEMENT, ETC., ETC.

Regenerative and Half-Regenerative Benches.

PORTLAND CEMENT.

Correspondence Respectfully Solicited.

GAS vs. ELECTRIC LIGHT.

We would invite attention to the able and exhaustive argument of General A. Hickenlooper, President of the Cincinnati Gas Light and Coke Company, contained in a handsome pamphlet of 96 pages, entitled

"EDISON'S INCANDESCENT ELECTRIC LIGHTS FOR STREET ILLUMINATION. REPORT OF AN ARGUMENT DELIVERED BY A. HICKENLOOPER BEFORE THE COMMITTEE ON LIGHT, MUNICIPAL COUNCIL, CITY OF CINCINNATI, JULY 22, 1886."

This is a subject of special interest to all Gas Light Companies.

Prices.

25 copies.....	\$7.50	100 copies.....	\$22.50
50 copies.....	12.50	250 copies.....	50.00

A sample copy will be sent by mail on receipt of 50 cts.

A. M. CALLENDER, & CO., 42 PINE ST., N. Y. CITY.

PATENTS.

FRANKLIN H. HOUGH,

Solicitor of American & Foreign Patents

925 F. ST., WASHINGTON, D. C.

(NEAR U. S. PATENT OFFICE.)

Personal attention given to the preparation and prosecution of applications for Letters Patent. All business before the U. S. Patent Office attended to for moderate fees. **No Agency in the United States possesses superior facilities for obtaining Patents,** or for ascertaining the patentability of inventions. Copies of patents furnished for 25 cents each. Correspondence solicited.

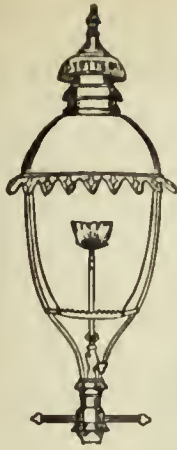

STEPHEN A. MORSE, President.
GODFREY REBMANN, Vice-Pres.

M. B. DYOTT,
Superintendent.

EDWIN F. MORSE, Secretary.
CARLTON M. WILLIAMS, Treas.

STANDARD GAS LAMP CO.,

Office, 411 Cherry St. Factory, 1101, 1103 & 1105 Frankford Av.

Philadelphia, Pa.

It is to the interest of Gas Companies and Cities to use Dyott's Patent Champion Lamps, which give double the light with the same consumption of gas, and will save 50 per cent. over others in cost of keeping in repair. Gas Companies and others intending to erect Lamps of any description will do well to communicate with us. Special Drawings furnished and Estimates given on application upon Architects', Engineers' or our Draughtsmen's Plans.

Our Patent System of Instantaneously Lighting Gas (without electricity) for R. R. Depots is unequalled. Our High Candle Power Burner is superior to the Electric Light or any other High Candle Burner. We manufacture every description of Ornamental Lamps.

KLOENNE & BREDEL

IMPROVED REGENERATIVE FURNACES.

Self-Sealing Mouthpieces & Bridge-Pipes, Retort Houses,

WASHER-SCRUBBERS

Gasholders, and Complete Gas Works.

Refers, by permission, to Mr. Eugene Vanderpool, of Newark, N. J.; Mr. E. G. Cowdery, of Milwaukee, Wis.; and Mr. Theo. Forstall, of Chicago, Ill. For further information apply to

FRED. BREDEL, 332 East 17th St., N. Y. City.

G. S. COOK, Pres.

THOS. DAVENPORT (late Davenport Bros.), Sec. & Treas

BARTLETT

Street Lamp Mfg. Co.

MANUFACTURERS OF

Bartlett's Patent

GLOBE LAMPS.

FOR

Streets, Parks, Railroad Stations, Public Buildings, Etc.

LAMP POSTS A SPECIALTY.

Office and Salesroom

40 & 42 College Place, N. Y. City.

Gas Companies and others intending to erect lamps and posts will do well to communicate with us.

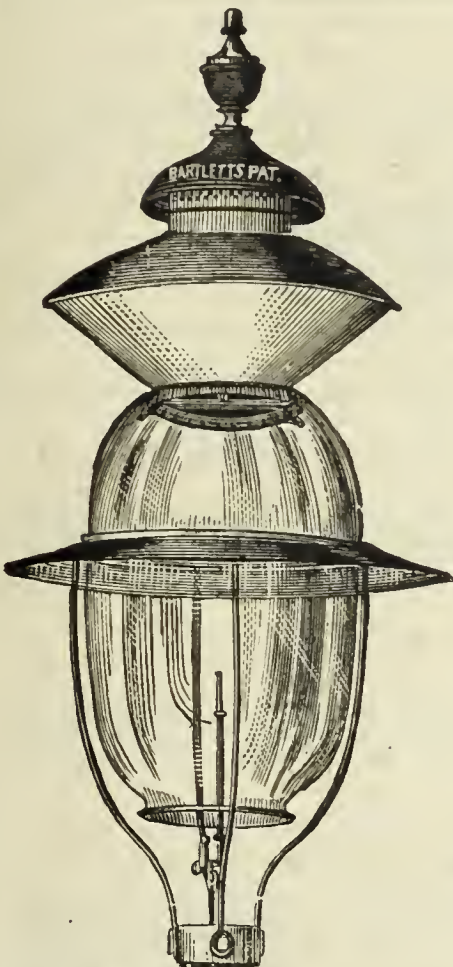

Ferric Oxide for Gas Purification.

Ferric Oxide, as ground, screened, and prepared by me for purifying purposes, has now been in use for several years by many of the gas works throughout the country, including Detroit, Chicago, Milwaukee, East Saginaw, Burlington (Iowa), Ann Arbor, etc. It has proved, as I believe, the **Most Effective and Economical Agent** now in use. I am prepared to furnish the Oxide by the 100 lbs. or in car load lots, and will be pleased to give price f.o.b. cars at Ann Arbor or at place of destination. Address

S. H. DOUGLAS, Prest. Ann Arbor (Mich.) Gas Light Co.

GAS AND WATER PIPES.

GAS AND WATER PIPES.

ENGINEERS.

SAM'L R. SHIPLEY, Pres.
HENRY B. CHEW, Treas.

JAS. P. MICHELLON, Sec.
WM. SEXTON, Supt.

GLOUCESTER IRON WORKS,
GLOUCESTER CITY, N. J.



Cast Iron Gas & Water Pipes, Stop Valves, Fire Hydrants, Gasholders, &c.

Office No. 6 North Seventh Street, Philadelphia.

MATTHEW ADDY, President.

W. L. DAVIS, Selling Agent.

GEO. P. WILSHIRE, Sec. & Treas.

Cincinnati and Newport Iron and Pipe Company,

NEWPORT, KY.

Lamp Posts

AND

BENCH CASTINGS

A Specialty.

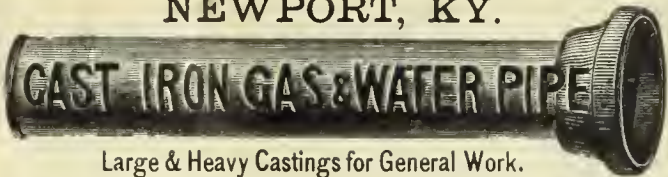

Large & Heavy Castings for General Work.

Branch

AND

SPECIAL CASTINGS

FOR GAS & WATER CO'S.

Manufacture Pipe from 2 to 48 inches. All work guaranteed first quality.

Pancoast & Rogers.

WROUGHT IRON PIPE,

VALVES AND GATES,

Cast Iron Gas & Water Pipe.

28 Platt and 15 Gold St., New York.

Water & Gas Pipe.

RUSTLESS

Send for New Catalogue.

RUSTLESS

The WELLS RUSTLESS IRON COMPANY,

Nos. 7 and 9 Cliff Street, New York City.

The Management of Small Gas Works.

By C. J. R. HUMPHREYS. Price, \$1.

A running commentary on the different sections of gas management with reference to small undertakings, with some notes on the erection of the necessary plant.

A. M. CALLENDER & CO., 42 Pine St., N. Y.

P. D. WANNER, Chairman. A. H. MELLERT, Sec. & Treas.
MELLERT FOUNDRY & MACHINE CO., Ltd.
Reading, Pa.



Specials—Flange Pipe, Valves and Hydrants, Lamp Posts, Retorts, etc.

General Foundry and Machine Work.

JOHN FOX, Selling Agent. 160 Broadway, N. Y.

THE OHIO PIPE COMPANY,

MANUFACTURERS OF

Cast Iron Gas & Water Pipe,

BRANCH AND SPECIAL CASTINGS.

Gas-House Bench Castings, Hydraulics, Lamp Posts, Flange Pipe and Specials, Architectural Castings, Building Columns, Joists, Cellar Grates, Sash Weights, etc.

GENERAL FOUNDERS AND MACHINISTS.

Columbus, Ohio.

M. J. DRUMMOND,



SPECIAL CASTINGS AND LAMP POSTS.

Equitable Building, 120 Broadway, N. Y.

JOS. R. THOMAS, C.E.,

May be Consulted on all Matters Relating to Gas Works and Gas Manufacture.

ADDRESS THIS OFFICE.

WM. MOONEY

(Successor to WM. FARMER)

27 Pearl Street, N. Y. City.

(One door from Whitehall Street.)

CONTRACTOR FOR THE ERECTION OF GAS WORKS, OR APPARATUS OF ANY CAPACITY. AGENT FOR WM. FARMER'S PATENTS.

Plans and Specifications Furnished.

WM. HENRY WHITE,

CONSULTING AND CONSTRUCTING

Gas Engineer & Contractor

Estimates, Plans, and Specifications furnished for new works or extensions of existing works.

No. 32 Pine Street, New York City.

Correspondence solicited.

WM. GARDNER,

Gas Engineer,

Lewis Block, Room 20, Pittsburgh, Pa.

Those who intend to make alterations in existing gas plants, or who contemplate the erection of new works, will find it to their interest to open correspondence with the above. Plans made, and estimates furnished.

GAS LAMPS.

SCRUBBERS AND CONDENSERS.

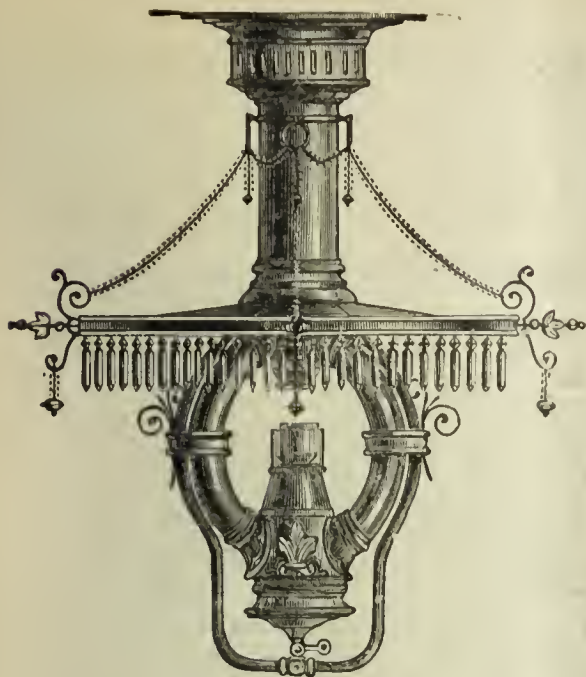

SIEMENS LAMP.

The Siemens and Lungren REGENERATIVE GAS LAMPS.

A System of Burning Gas whereby its Illuminating Power is Increased from 300 to 400 per ct. without the Expense, Trouble and Annoyance resulting from the use of Hydrocarbon Enriching Material.

The Siemens-Lungren Company received the only Silver Medal or Highest Award for Gas Burners at the "Novelties" Exhibition of the Franklin Institute, held at Phila., Oct., '85.

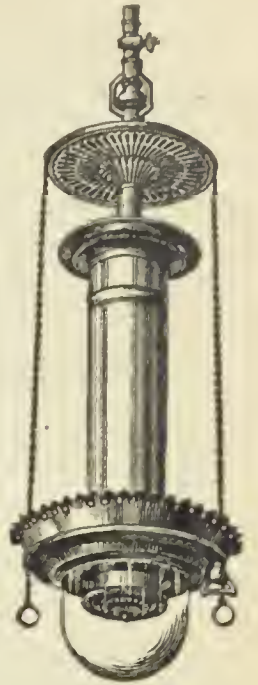

LUNGREN LAMP

THIRTEEN CANDLE POWER PER CUBIC FOOT OF GAS!

This result is obtained

SIMPLY BY THE SCIENTIFIC APPLICATION OF THE REGENERATIVE PRINCIPLE.

Consequently this largely increased illumination is always maintained without further cost and frequent attention.

THE SIEMENS-LUNCREN COMPANY,

N. E. Cor. 21st. St. and Washington Av., Phila.. Pa.

KIRKHAM, HULETT & CHANDLER, Limited,
London, S. W., England.

PATENT "STANDARD" WASHER-SCRUBBERS.

Following are extracts from letters received from some of the Gas Light Companies now using the "Standard" Washer-Scrubber:

GEO. SHEPARD PAGE, Esq.:

SAN FRANCISCO, Sept. 21, 1887.

Dear Sir—In reply to yours, would say that the ammonia is entirely removed from the gas by the use of the "Standard" Washer Scrubber.

Yours truly, J. B. CROCKETT, Prest.,
San Francisco Gas Lt. Co.

GEO. SHEPARD PAGE, Esq.:

BOSTON, Mass., Aug. 30, 1887.

Dear Sir—The "Standard" Washer-Scrubber at these works is giving good satisfaction, and the increased amount of ammonia eliminated from the gas by its use enables us to obtain a larger income from the ammoniacal liquor.

Truly yours, THOS. J. PISHON, Supt.,
Roxbury Gas Lt. Co.

GEORGE SHEPARD PAGE, Esq.:

GEORGETOWN, D. C., Sept. 27, 1887.

Dear Sir—The "Standard" Washer-Scrubber, together with all the work of connecting the same with these works, has given entire satisfaction.

Truly yours, J. B. CATHELL, Supt.,
Georgetown Gas Lt. Co.

GEORGE SHEPARD PAGE, Esq.:

BROOKLYN, N. Y., Sep. 8, 1887.

Dear Sir—By the use of the "Standard" Washer-Scrubber at these works the ammonia is entirely removed from the gas, and our income from the ammoniacal liquor has been increased 100 per cent.

Yours truly,
C. W. BLODGET, Sec.,
Williamsburgh Gas Lt. Co.

GEO. SHEPARD PAGE, 69 WALL STREET, NEW YORK,

Agent for the Western Hemisphere.

GAS WORKS APPARATUS AND CONSTRUCTION.

GAS WORKS APPARATUS AND CONSTRUCTION.

WORKS: { MILLVILLE, N. J.
FLORENCE, " "
CAMDEN, " "

R. D. WOOD & CO.,

OFFICES: { 400 CHESTNUT ST.,
PHILADELPHIA.

GAST-IRON PIPE 1½ to 72 Inches in Diameter.

Water Machinery and Gas Apparatus.

HEAVY CASTINGS.

HOLDERS,

LAMP POSTS,

VALVES,

PURIFIERS,

CONDENSERS,

BENCH WORK,

METER CASES.

FLOORS AND ROOFS,

FLANGED PIPE,

FIRE HYDRANTS,

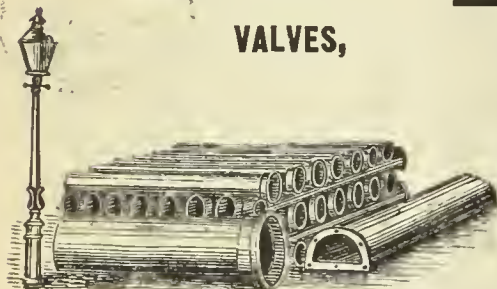
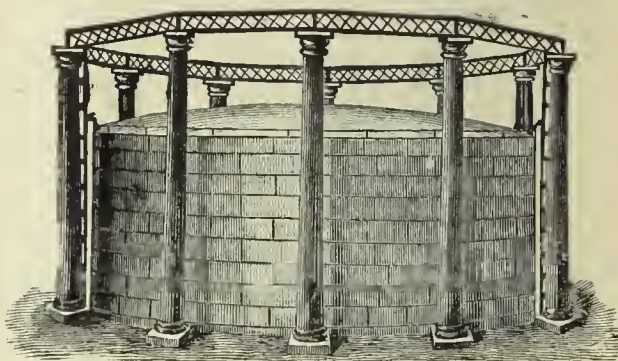

Estimates and Specifications for
NEW WORKS or EXTENSIONS
or ALTERATIONS of OLD ONES.

GASHOLDER TANK CONSTRUCTION, ETC.

Gas Companies and others about to erect Gasholders will find it profitable to consult W. C. WHYTE, who for over thirty years has made a specialty of

Holder Tank Excavation and Mason Work.

Fifty tanks now in operation show the sort of work done. Address

W. C. WHYTE, No. 15 Cortlandt St., N. Y. City.

MORRIS, TASKER & CO.,

Limited,

Builders of Gas Works,

PHILADELPHIA PA.

GASHOLDERS, PURIFIERS, SCRUBBERS, CONDENSERS, EXHAUSTERS,

Bench Castings, Iron Roofs, Lamp Posts

VALVES, STREET MAIN SPECIALS, ETC.,

MANUFACTURED BY

KERR MURRAY MANUFACTURING COMPANY

From 1880 to 1886, inclusive, we erected Gasholders for the following cities, viz.:

Adrian, Mich.	East End Gas Co., Pitts-	Janesville, Wis.	New Castle, Pa.	Valparaiso, Ind.
Akron, Ohio.	burgh, Pa.	Johnstown, Pa.	Niagara Falls, N. Y.	Van Wert, Ohio.
Albuquerque, N. M.	East Saginaw, Mich.	Key West, Fla.	Osawatomie, Kans.	Wabash, Ind.
Altoona, Pa.	Elgin, Ills.	La Crosse, Wis.	Pittsburgh, Pa. (2)	Waco, Texas.
Anderson, Ind.	Evanston, Ills.	Lebanon, Ind.	Plainfield, Ind.	Waukesha, Wis.
Bellaire, Ohio.	Eufaula, Ala.	Lima, Ohio.	Portage City, Wis.	Wheeling, West Va.
Birmingham, Ala.	Frankfort, Ind.	Logan, Ohio.	Sedalia, Mo.	Wellington, Kans.
Bucyrus, Ohio.	Freeport, Ills.	Louisville, Ky.	Sheboygan, Wis.	West Pittsburgh, Pa.
Canton, Ohio.	Galesburg, Ills.	Mankato, Minn.	South Bend, Ind.	Xenia, Ohio.
Circleville, Ohio.	Grafton, West Va.	Mansfield, Ohio.	South Chicago, Ills.	Youngstown, Ohio.
Colorado Springs, Col.	Greensburg, Pa.	Marshalltown, Iowa.	Springfield, Ills.	Ypsilanti, Mich.
Danbury, Conn.	Huntington, Ind. (2)	Meridian, Miss.	Streator, Ills.	
Delaware, Ohio.	Ironton, Ohio.	Minneapolis, Minn.	Topeka, Kans.	
Delphos, Ohio.	Jamestown, N. Y.	Muskegon, Mich.	Uniontown, Pa.	

Under construction, 1887.

Akansas City, Kans.	Grand Forks, Dakota.	Mobile, Ala.	Santa Fe, N. M.	Fuel Gas and Electric Engi-
Dallas, Texas.	Grand Rapids, Mich.	Pittsburgh, Pa.	Wichita, Kans.	neering Co., Pittsburgh, Pa.
El Paso, Texas.	La Crosse, Wis.	Pine Bluff, Ark.	Lexington, Mo.	Stillwater, Minn.

Estimates, with Plans and Specifications, for new or the rebuilding of old works, furnished on application. Correspondence solicited. Address

KERR MURRAY MANUFACTURING CO.,

A. D. CRESSLER, General Manager.

FORT WAYNE IND.

GAS WORKS APPARATUS AND CONSTRUCTION.

GAS WORKS APPARATUS AND CONSTRUCTION.

JAMES R. FLOYD,

(SUCCESSOR TO HERRING & FLOYD)

Oregon Iron Works,

531 to 543 West 20th St., N. Y.

Practical Builders of Gas Works,

MANUFACTURERS OF

ALL KINDS OF CASTINGS

AND

APPARATUS FOR GAS-WORKS.

BENCH CASTINGS

from benches of one to six Retorts each.

WASHERS: MULTITUBULAR AND AIR CONDENSERS; CONDENSERS; SCRUBBERS

(wet and dry), and

EXHAUSTERS

for relieving Retorts from pressure.

BENDS and BRANCHES

all sizes and description.

FLOYD'S PATENT

MALLEABLE RETORT LID.

PATENT

SELF-SEALING RETORT LIDS.

FARMER'S

PATENT BY-PASS DIP-PIPE.

SABBATON'S PATENT

FURNACE DOOR AND FRAME.

BUTLER'S

COKE SCREENING SHOVELS.

GAS GOVERNORS,

and everything connected with well regulated Gas Works at low price, and in complete order.

SELLER'S CEMENT

for stopping leaks in Retorts.

N. B.—**STOP VALVES** from three to thirty inches at very low prices.

Plans, Specifications, and Estimates furnished.

THE CONTINENTAL IRON WORKS.

THOS. F. ROWLAND, Prest. WARREN E. HILL and CHAS. H. CORBETT, V.-Pres. THOS. F. ROWLAND, JR., Sec. & Treas.



GAS HOLDERS OF ANY MAGNITUDE.

P. O. Station G., BROOKLYN, N. Y.

ENGINEERS AND MANUFACTURERS OF

Gas Holders

CONDENSERS, SCRUBBERS, VALVES,

PURIFIERS, SELF-SEALING RETORT LIDS,

Hydraulic Mains,

And all other articles connected with the manufacture and distribution of Gas.

H. RANSIAW, Prest. & Mangr. WM. STACEY, Vice-Prest. T. H. BIRCH, Asst. Mangr. R. J. TARVIN, Sec. & Treas.

STACEY MFG. CO.,

MANUFACTURERS OF

Single and Telescopic Gasholders,

IRON ROOFS, BRIDGES, LAMP POSTS,

Water and Oil Tanks, Coal Elevator Cars,

COKE CRUSHERS, BENCH CASTINGS,

And all kinds of Wrought and Cast Iron Work used in the erection of Coal and Oil Gas Works. Rolling Mill Machinery and Heavy Castings a Specialty.

Foundry:

33, 35, 37 & 39 Mill Street.

Wrought Iron Works:

16, 18, 20, 22, 24 & 26 Ramsey Street:

Cincinnati, Ohio.

Bouton Foundry Co.,

FOUNDERS AND MACHINISTS,

CHICAGO, ILL.

Gas Works Apparatus,

PURIFIERS, CONDENSERS,

Bench Work,

SPECIALS, LAMP POSTS,

SCRUBBERS,

Iron Roofs and Floors.

Plans and Estimates furnished for new works or extensions of old works.

1842. **DEILY & FOWLER,** 1887.

Laurel Iron Works.

Address, No. 39 Laurel Street, Philadelphia, Pa.

MANUFACTURERS OF

GASHOLDERS,

Single and Telescopic.

Holder Built 1882 to 1886, Inclusive:

- | | | | | |
|----------------------------|--------------------------|----------------------------|----------------------------|---------------------------|
| Denver, Col. | Warren, Ohio. | Allegheny, Pa. (21.) | York, Pa. | Salem, N. J. (2d) |
| Chicago, Ill. (West Side). | Bath, N. Y. | Atlanta, Ga. (2d.) | Chester, Pa. | Omaha, Neb. (2d) |
| Pittsburgh, Pa. (S. Side) | Lynn, Mass. | N.Y. City (Central Gas Co) | Hazleton, Pa. (2d.) | Lynn, Mass. (2d) |
| Pawtucket, R. I. | New Bedford, Mass. | Lynchburg, Va. (2d.) | Staten Island, N. Y. | Little Rock, Ark. |
| Brookline, Mass. | Waterbury, Conn. | Saylesville, R. I. | Saugerties, N. Y. | Irvington, N. Y. |
| Sherbrooke, Can. | Deseronto, Can. | Rondout, N. Y. | Clinton, Mass. (Lan Mills) | South Boston, Mass. |
| Burlington, N. J. (2d) | Hoosic Falls, N. Y. (2d) | Atlantic City, N. J. | Chattanooga, Tenn. | Rye, N. Y. (2) |
| Bridgeton, N. J. | Bethlehem, Pa. | Augusta, Ga. | Galveston, Texas. (3d.) | Woodstock, Ont. 5 |
| Bay City, Mich. | Atlanta, Ga. (1st.) | Waltham, Mass. (2) | Omaha, Neb. | Malden, Mass. |
| Erie, Pa. | Savannah, Ga. | Mahanoy City, Pa. | Fort Plain, N. Y. | Staten Island, N. Y. (2d) |
| Jackson, Mich. | Montgomery, Ala. | New Castle, Pa. | Brunswick, Ga. | |
| Kalamazoo, Mich. (3d.) | Newport, R. I. | Long Island City, N. Y. | Port Chester, N. Y. | |
| Glen Island, N. Y. | Portland, Oregon. | Macon, Ga. | New Rochelle, N. Y. | |

SMITH & SAYRE MFG. COMPANY,

G. PORTER, Prest.

245 Broadway, N. Y.

CHAS. W. ISBELL, Sec'y.

Machinery & Apparatus for Gas Works

Drawings, Plans, and Estimates Furnished for the Improvement, Extension, or Alteration of Gas Works, or for the Construction of New Works.

Mackenzie's Patent Rotary and Steam Jet Gas Exhausters, Governors, Compensators, Condensers, Washers, Scrubbers. Isbell's Patent Automatic Street Pressure Governor Gas and Water Valves, Hydraulic Main Dip Regulator, Bench Castings, etc. Purifying Boxes and "Standard" Scrubbers. Isbell's Patent Self-Sealing Retort Doors.

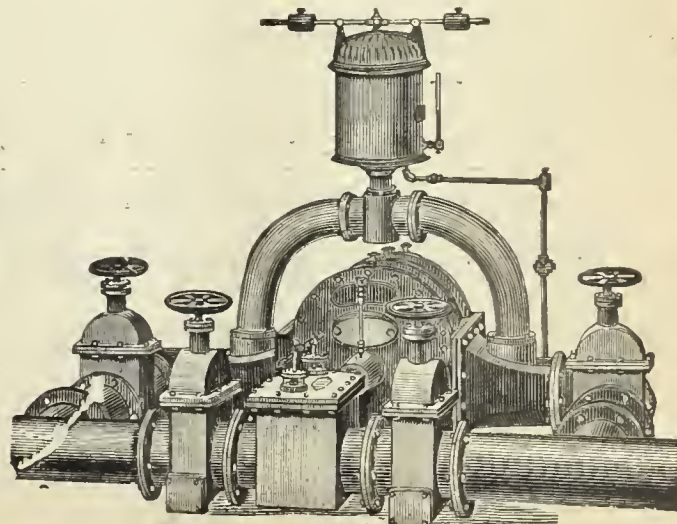

GAS COALS.

CANNEL COALS.

GAS ENRICHERS.

JAMES D. PERKINS.

PERKINS & CO.,

F. SEAVERNS.

General Sales Agents for

The Youghioghenny River Coal Company's**OCEAN MINE YOUGHIOGHENY GAS COAL.**

The Coal from the Ocean Mine (recently operated by *Messrs. W. L. Scott & Co.*, of Erie, Pa.,) is now used by all the leading Gas Companies in the United States from Maine to Texas, and is recognized as *the only reliable Youghioghenny Gas Coal.* (See Map on p. 87 of this Journal, Feb. 16, '85.)

P. O. Box 3695,
New York.**PERKINS & CO., 228 and 229 N. Y. Produce Exchange.**BEAVER STREET
ENTRANCE.**BRECKENRIDGE CANNEL,
OF KENTUCKY.**

This Colliery was re-opened in June, 1886, since which date the Cannel has been delivered to over sixty of the leading Gas Companies in this country and in Europe. As an enricher ONE TON of this Cannel will do the work of TWO TONS of any other available Cannel, and is more economical than Naptha or Oil of any character. It can be delivered in parcels of one car load or more to any point in the United States or Canada.

(See AMERICAN GAS LIGHT JOURNAL, June 16, '86, pp. 346-7.)

P. O. Box 3695,
New York.**PERKINS & CO., 228 and 229 N. Y. Produce Exchange**BEAVER STREET
ENTRANCE.**JAMES & WILLIAM WOOD,****Gas and Cannel Coal Contractors,**

No. 40 St. Enoch Sq., Glasgow. No. 2 Talbot Court, London.

Proprietors of the **BATHVILLE COLLIERIES** (which produce the celebrated **BOGHEAD CANNEL**), Shields, Shieldmuir, Drumpeller, and other Collieries. This Firm offer

STANDARD CANNELS,**Unequaled as Gas Enrichers.**

Analyses, prices, and all further information furnished on application to

Agency for U. S., Room 93, Nos. 2 & 4 Stone St., N.Y. City.**The Standard Oil Company,**

REFINERS OF

NAPTHA AND GASOLINES.

ALSO MANUFACTURERS OF

**A Special Grade of Naptha for
Gas Companies****FOR ENRICHING COAL GAS.**

Correspondence solicited.

No. 43 Euclid Avenue, Cleveland, Ohio.

To Gas Companies.We make to order **CAP BURNERS** to burn any amo
under a stated pressure. Send for samples.Also, **SERVICE CLEANERS, DRIP PUMPS, and STRE
MAIN PROVING APPARATUS.****C. A. GEFROER,**

248 N. 8th Street, Phila., Pa.

GOODWIN'S DIRECTORY**OF THE GAS LIGHT COMPANIES of the UNITED STATES & CANADA.**Price, **\$8.00.**

Orders may be sent to

A. M. CALLENDER & CO., No. 42 Pine Street, N. Y. City.

COKE CRUSHERS.

Newburgh Orrel Coal and Coke Co.

MINERS AND SHIPPERS OF

Mountain Brook Steam and Smithing Coals,

**NEWBURGH, PALATINE,
AURORA & TYRCONNELL
GAS COALS.**

Foundry & Crushed Coke Shipped Direct from Ovens

Mines Situated at

Newburgh, Flemington & Fairmont, W.Va.

HOME OFFICE,

33 S. Gay St., Baltimore.

CHAS. MACKALL, Gen. Mangr.

CHAS. W. HAYS, Agent in New York,

Room 147, WASHINGTON BUILDING, No. 1 Broadway.

Shipping wharves at Locust Point, Baltimore.

THE DESPARD COAL COMPANY

OFFER THEIR SUPERIOR

DESPARD COAL

To Gas Light Companies and Manufacturers of Fire Clay Goods
Throughout the Country.

ROUSSEL & HICKS, } AGENTS. { BANGS & HORTON,
71 Broadway, N. Y. } { 16 Kilby St., Boston.

Mines in Harrison Co., West Va. Wharves, Locust Point, Balt.

Company's Office, 15 German St., Baltimore, Md.

Among the consumers of Despard Coal we name: Manhattan
Gas Light Co., N. Y.; Metropolitan Gas Light Co., N. Y.; Jersey
City, (N. J.) Gas Light Co.; Washington (D. C.) Gas Light Co.;
Portland (Maine) Gas Light Co. Reference to them is requested.

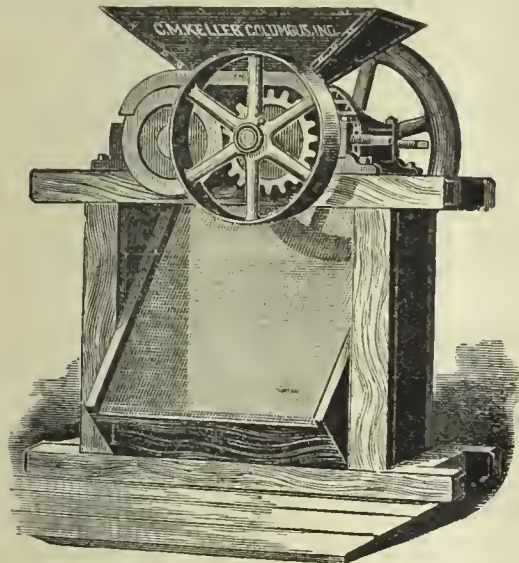

Keller's Adjustable Coke Crusher.

SIMPLE, STRONG, AND DURABLE.

C. M. Keller, Sec. & Supt. Gas Lt. & Coke Co. Columbus, Ind.

Correspondence Solicited.

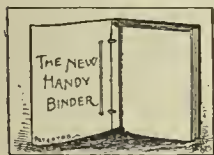

**THE NEW
HANDY BINDER.**

This article may be described as elegant
in appearance, strong, durable, and possessing many special
qualities of its own. It allows the opening of the pages per-
fectly flat, whether one or several numbers are in the binder
Any number can be taken out and replaced without disturbing
the others. The papers are not mutilated for subsequent bind-
ing in permanent form. The binder is supplied with gilt side
title, and is an ornament to any desk or reading table. The
JOURNAL, filed in the Handy Binder, becomes a volume of great
value, always convenient for instant reference. **Handy Binder,**
Postage paid, \$1.00.

A. M. CALLENDER & CO., 47 Pine St., N. Y.

GAS COALS.

GAS COALS.

THE
PENN GAS COAL CO.

OFFER THEIR

Coal, Carefully Screened & Prepared for Gas Purposes.

Their Property is located in the Youghiogeny Coal Basin, near Irwin and Penn Stations on the
Pennsylvania Railroad, and on the Youghiogeny River.

Principal Office:

209 SOUTH THIRD STREET, PHILA., PA.

Points of Shipment:

Pennsylvania Railroad Piers; Greenwich Wharves, Delaware
River; Pier No. 1 (Lower Side), South Amboy, N. J.

Chesapeake & Ohio Railway Coal Agency,

FOR THE SALE OF THE

**Superior Kanawha Gas Coals, Cannelton Cannel,
Also, SPLINT AND STEAM COALS,**

From the Kanawha and New River Regions, on the line of the Chesapeake & Ohio R'way.

C. B. ORCUTT, Sales Agent. | OFFICE, 150 BROADWAY, N. Y.

FRANCIS H. JACKSON, Prest. EDMUND H. MCCULLOUGH, V.-Prest. CHAS. F. GODSHALL, Treas. H. C. ADAMS,

THE WESTMORELAND COAL CO.

Chartered 1854.

**Mines situated on the Pennsylvania and the Baltimore
and Ohio Railroads, in Westmoreland County, Penn.**

POINTS OF SHIPMENT:

PHILADELPHIA, BALTIMORE, SOUTH AMBOY, N. J.,
WATKINS (SENECA LAKE), N. Y.

Since the commencement of operations by this Company its well-known
Coal has been largely used by the Gas Companies of New England and the
Middle States, and its character is established as having no superior in gas
giving qualities, and in freedom from sulphur and other impurities.

Principal Office, 224 South 3d St., Phila., Pa.

A. M. SCOTT, PRESIDENT. A. DEMPSTER, C.E., SECRETARY. W. K. GILLESPIE, TREASURER.

MONONGAHELA AND PETERS CREEK GAS COAL CO.,

PRODUCERS OF

Coal Bluff Gas Coal.

MINES LOCATED ON THE MONONGAHELA DIVISION OF THE PENNSYLVANIA RR.,
IN THE CENTRAL PORTION OF THE PITTSBURGH COAL FIELD.

Points of Shipment—Buffalo, Cleveland, Erie, Chicago, New Orleans.

Since the introduction of Coal Bluff Gas Coal it has taken rank among the few first-class Gas Coals, and ac-
knowledges no superior in gas-giving qualities, ease of working, quality of coke, and freedom from impurities.

General Office, 43 Sixth Ave., Pittsburgh, Pa.

GAS METERS.

GAS METERS.

GAS METERS.



INTERNATIONAL--1876--EXHIBITION.

The U. S. Centennial Commission

HAVE DECREED AN AWARD TO

HARRIS, GRIFFIN & CO.,

Twelfth and Brown Streets, Philadelphia, Pa. No. 49 Dey Street, N. Y. City, and No. 75 North Clinton Street, Chicago, Ill.

FOR THE FOLLOWING REASONS:

The Exhibit consists of a Series of METERS from the Largest Size Station Meters for the use of the MANUFACTURE OF GAS, to those for the use of the ORDINARY CONSUMER. The Instruments are WELL MADE, RELIABLE as to INDICATION, and embody a number of sundry improvements which, with the general character of the Exhibit, entitle the whole to commendation.

Attest—J. L. CAMPBELL,
Secretary, pro-tem.

Signed—A. T. GOSHORN,
Director General

J. R. HAWLEY,
President



Dry Gas Meter.

With 39 years' experience and the best facilities for manufacturing, is enabled to furnish reliable work and answer orders promptly.

NATHANIEL TUFTS,

No. 153 Franklin Street, Boston, Mass.,

MANUFACTURER OF

DRY GAS METERS.

Station Meters of any Capacity.

Test and Experimental Meters, Pressure Registers, Pressure Gauges,
Pressure and Vacuum Gauges.

METER PROVERS, PHOTOMETERS, STREET LANTERNS, ETC., ETC.

Patent Cluster Lanterns for Street Illumination.

SCIENTIFIC BOOKS.

We are prepared to furnish to Gas Managers, and others interested in the topics treated of, the following books, at prices named:

KING'S TREATISE ON THE MANUFACTURE OF COAL GAS. Three vols.; \$10 per vol.	PRACTICAL TREATISE ON HEAT, by THOMAS BOX. Second edition. \$5.	THE GAS MANAGER IN THE LABORATORY, by a Practica Student. 8vo., Cloth. \$1.50.
GAS MANUFACTURE, by WILLIAM RICHARDS. 4to., with numerous Engravings and Plates, in Cloth binding. \$12.	GAS WORKS—THEIR ARRANGEMENT, CONSTRUCTION, PLANT, AND MACHINERY. \$8.	THE DOMESTIC USES OF COAL GAS, AS APPLIED TO LIGHTING, by W. SUGG. \$1.40.
THE GAS ANALYST'S MANUAL, by F. W. HARTLEY. \$2.50.	COAL; ITS HISTORY AND USE. by PROF. THORPE. \$3.50.	DISTILLATION OF COAL TAR AND AMMONIACAL LIQUOR by GEO. LUNGE. New Edition. \$12.50.
TECHNICAL GAS ANALYSIS. \$2.80.	THE GAS WORKS OF LONDON, by COLBURN. 60 cents.	A TREATISE ON THE COMPARATIVE COMMERCIAL VALUES OF GAS COALS AND CANNELS, by D. A. GRAHAM 8vo., Cloth. \$3.
GAS MANAGER'S HANDBOOK, by THOS. NEWBIGGING. \$4.80.	THE GAS FITTER'S GUIDE, Showing the Principles and Practice of Lighting with Coal Gas, by JOHN ELDREDGE. 40 cents.	GAS AS A SOURCE OF LIGHT, HEAT, AND POWER, by C. J. R. HUMPHREYS. 10 cents.
GAS CONSUMER'S GUIDE. \$1.	GAS WORKS, AND MANUFACTURING COAL GAS, HUGHES. \$2.20.	GAS COMPANIES DIRECTORY. \$3.
A GUIDE TO GAS LIGHTING. 40 cents.	THE MANAGEMENT OF SMALL GAS WORKS, by C. J. R. HUMPHREYS. \$1.	GAS VERSUS ELECTRIC LIGHT. 50 cents.
GAS MEASUREMENT AND GAS METER TESTING, by F. W. HARTLEY. \$1.60	MANUAL FOR GAS ENGINEERING STUDENTS, by D. LEE, 40 cents.	PURIFICATION OF COAL GAS, by R. P. SPICE. 8vo. \$3.
GAS CONSUMER'S HANDBOOK, by WILLIAM RICHARDS, C.E.; 18mo., Sewed. 20 cents.	HOW TO MANAGE GAS, by F. WILKINS. Paper. 20 cents.	
A PRACTICAL TREATISE ON GAS AND VENTILATION with Special Relation to Illuminating, Heating, and Cooking by Gas, by E. E. PERKINS. \$1.25.		

The above will be forwarded by express, upon receipt of price. We take especial pains in securing and forwarding any other Works that may be desired, upon receipt of order. All remittances should be made by check, draft, or post office money order.

A. M. CALLENDER & CO., No. 42 Pine Street, New York.

KING'S TREATISE ON COAL GAS.

The most complete work on Coal Gas ever published. Three vols., bound \$30.

A. M. CALLENDER & CO., No. 42 Pine Street, New York.

GAS METERS.

GAS METERS.

GAS METERS.

GEO. J. MCGOURKEY, Pres. WM. H. McFADDEN, Vice-Pres. (Phila.) WM. N. MILSTED, Gen. Supt. & Treas. (New York). WM. H. DOWN Sec.

AMERICAN METER COMPANY,

WET AND DRY GAS METERS.	PRESSURE REGISTERS.	METER PROVERS.
STATION METERS.	PRESSURE & VACUUM REGISTERS.	PORTABLE TEST METERS.
EXHAUSTER GOVERNORS.	PRESSURE & VACUUM GAUGES.	EXPERIMENTAL METERS.
DRY CENTRE VALVES.	CRESSON GAS REGULATORS.	AMMONIA TEST METERS.
GOVERNORS FOR GAS WORKS.	MARSLAND WATER METERS.	BAR AND JET PHOTOMETERS.

Manufactories:
512 W. 22d St., N. Y.
Arch & 22d Sts., Phila.

GAS STOVES,
SUGG'S "STANDARD" ARGAND BURNERS,
SUGG'S ILLUMINATING POWER METER,
Wet Meters, with Lizar's "Invariable Measuring" Drum.

Agencies:
177 Elm Street, Cincinnati.
214 & 216 N. Wells Street, Chicago.
810 North Second Street, St. Louis.
222 Sutter St., San Francisco.

HELME & McILHENNY,

(Successors to Harris & Brother. Established 1848.)

GAS METER MANUFACTURERS,

CONTINUE AS HERETOFORE AT THE OLD ESTABLISHMENT,

Nos. 1339 to 1349 Cherry Street, Philadelphia, Pa.,

To Manufacture Wet and Dry Gas Meters, Station Meters, Experimental Meters, Meter Provers, Center Seals, Pressure Registers
GOVERNORS, INDICATORS, PHOTOMETERS, & ALL OTHER KINDS OF APPARATUS FOR USE IN GAS WORKS.

From our long practical experience of the business, and from our personal supervision of all work, we can guarantee all orders to be executed promptly and in every respect satisfactorily.

WM. WALLACE GOODWIN, Prest. and Treas.

WM. H. MERRICK, V.-Prest.

S. L. JONES, Sec.

S. V. MERRICK, Supt.

THE GOODWIN GAS STOVE AND METER COMPANY,

Successors to W. W. GOODWIN & CO.

1012, 1014 and 1016 Filbert St., Phila., Pa.

142 Chambers St., New York.

76 Dearborn St., Chicago, Ill.

WALDO BROS., Agents, 88 Water St., Boston.

MANUFACTURERS OF THE "SUN DIAL" GAS STOVES, FOR COOKING AND HEATING PURPOSES.

Dry and Wet GAS METERS, Station Meters (Square, Cylindrical, or in Staves) Glazed Meters, King's and Sugg's Experimental Meters, Lamp Post Meters, Etc., Etc., Meter Provers (sizes 2, 5 and 10 feet), Pressure Gauges of all kinds, Pressure Registers, Pressure and Vacuum Registers, Pressure Indicators (sizes 4 inch, 6 inch and 9 inch), King's Pressure and Vacuum Gauges, Dry and Wet Centre Seals, Dry and Wet Governors, Exhauster Governors, Photometers of all descriptions. Letheby's Sulphur and Ammonia Test Apparatus complete—also Testing and Chemical Apparatus of all kinds, and of the most perfect description, for all purposes relating to Gas.

GOODWIN'S IMPROVED LOWE'S JET PHOTOMETER.

Agents for Bray's Patent Gas Burners and Lanterns.

Special attention to repairs of Meters, and all apparatus connected with the business.
All work guaranteed first class in every particular, and orders filled promptly.

G. B. EDWARDS, Mang'r, New York.
E. H. B. TWINING, Mang'r, Chicago.
Represented by S. S. STRATTON.

D. McDONALD & CO.,

GAS METER MANUFACTURERS.

(Established 1854.)

51 Lancaster St., Albany, N. Y. 34 & 36 West Monroe St., Chicago, Ill.

STATION METERS, EXPERIMENTAL METERS, METER PROVERS, PRESSURE & VACUUM REGISTERS, PRESSURE GAUGES, ETC.

Also STAR GAS STOVES, RANGES, and HEATING STOVES.

We use only the very best materials, and employ the most skilled labor, and by our long experience (32 years) and personal supervision of every detail, we feel justified in assuring the public that our goods will give perfect satisfaction. Every Meter emanating from our establishment will bear the State Inspector's BADGE, and will be fully warranted by us. Our Annual and Calendar will be sent to Gas Companies upon application.

GAS ENGINES.

GAS ENGINES.

“Otto”

Gas Engine Works,

Schleicher, Schumm & Co.,

**CHICAGO,
PHILADELPHIA.**

New York Agency,

18 VESEY ST.

New “Otto”

Vertical Gas Engine,

GIVING

ONE HORSE POWER

ON THE PULLEY.

Price, - \$290

At Shops in

PHILADELPHIA.

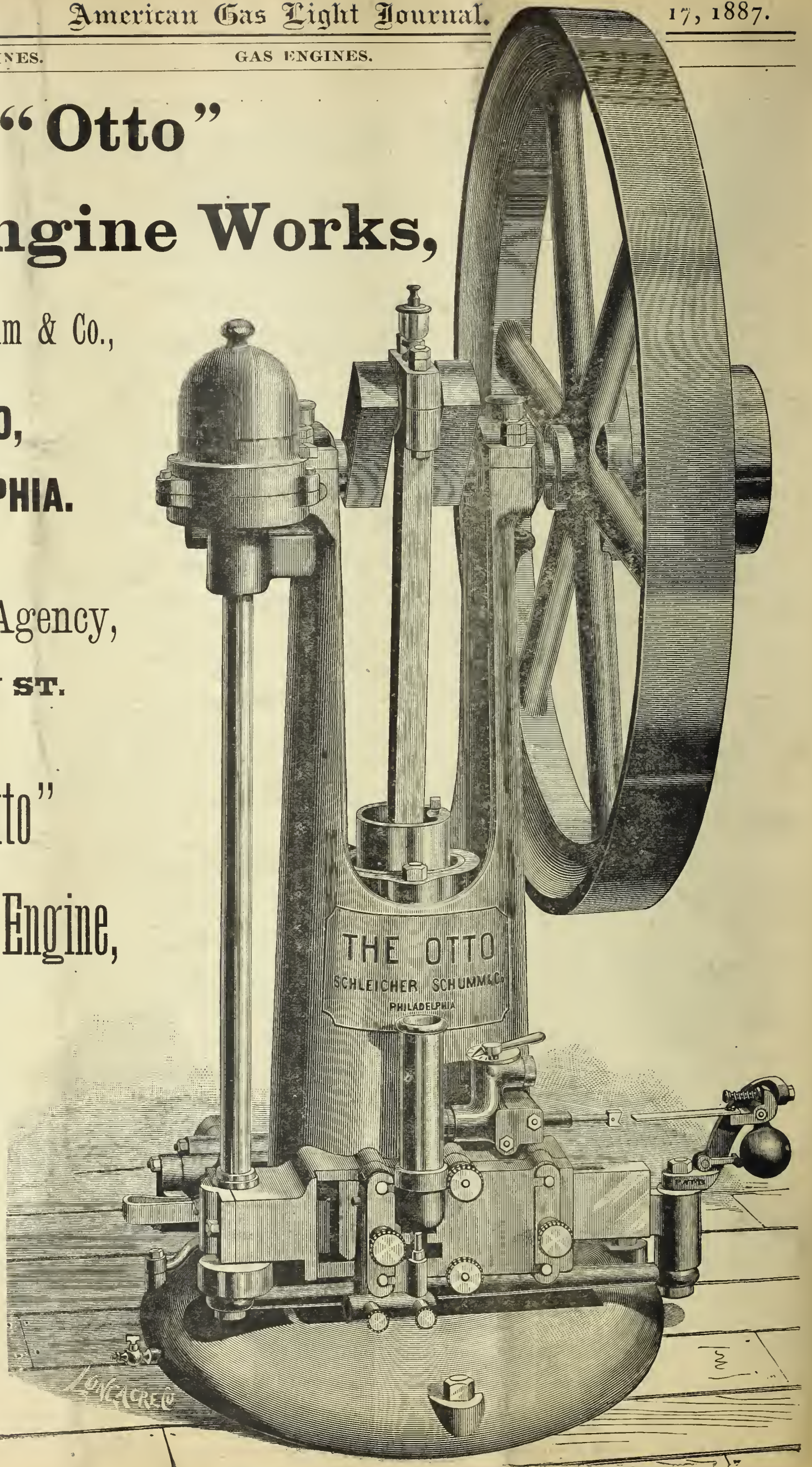

THE AMERICAN

GAS LIGHT JOURNAL

REDMAN & KENNY, N. Y.

PUBLISHING OFFICE No. 42 PINE STREET

DEVOTED TO THE INTERESTS OF ILLUMINATION, VENTILATION, WATER SUPPLY AND DISTRIBUTION, & GENERAL SCIENCE.

VOLUME XLVII.—No. 9. }
Whole No. 681.

NEW YORK, WEDNESDAY, NOVEMBER 2, 1887.

{ \$3 PER ANNUM,
IN ADVANCE.

A. M. CALLENDER & CO., Proprietors. C. E. SANDEBSON, Manager.
JOS. R. THOMAS, C.E., Editor. T. J. CUNNINGHAM, Asst. Editor.

ENTERED AT THE POST OFFICE AT NEW YORK, N. Y.
AS SECOND CLASS MATTER.

CONTENTS.

An Asterisk (*) denotes an illustrated article.

EDITORIALS—

The New York Meeting.....	257
Effect of Carbonic Acid on the Illuminating Power of Coal Gas, by C. W. Hinman.....	258
Special English Correspondence.....	259

Effect of Gas on the Blinding of Books—A Coal Gas Basis—The Claus Process—Advice to Gas Consumers—New Filling for Coke Scrubbers—The North of Ireland Association of Gas Managers.

ITEMS OF INTEREST FROM VARIOUS LOCALITIES..... 260

Public Lighting at Detroit, Mich.—Getting Ready for the Winter's Work—Public Lighting at Morristown, N. J.—Approaching a Termination—The Cost of it at Paris, Ill.—In Place of T. B. Catherwood—It Might have been Worse—Doubling Up—Electric Light in San Francisco, Cal.—A Retort House Roof Comes Down—In New Hands—All Improvements—Killed by the Current—Contributed by the Gas Company—Did Some of the Money go to his Shirtmaker?—Incorporated—In Working Order—Refused—Electric Light for Catskill, N. Y.—A Word from Denver, Col.—Elected Directors—Public Lighting at Hoosick Falls, N. Y.—How Officials are Selected at Wheeling, West Va.—Gas for Moorhead, Minn.—In Charge at Cheyenne, Wyo. Ter.—The Dallas City (Tex.) Boom Still in Bloom—Resigned—The Cost of It—At Work—Personal—Public Lighting at Stockton, Cal.—Plenty of Zirconia—Change in Title—Annual Election, Mansfield, Ohio—The Combination Plan at Columbus, Ga.—Electric Eccentricities at New Orleans, La.—Improvements on the Stamford (Conn.) Plant—The Candle Power—Public Lamps, Chicago, Ill.—No Gasoline in Buffalo's Gas—Elected—Well!—In Favor of Plaintiff—Reorganized—Cheaper Gas for San Antonio, Tex.—New Gas Company—An Item from Tremont, Neb.—Public Lighting at Butte, Montana.

Fifteenth Annual Meeting American Gas Light Association—Official Report..... 263

First Day, Morning Session—Routine Business—Applications for Membership—Roll Call—Report of Treasurer and Secretary—Report of Executive Committee, including Draft of Proposed Constitution—Discussing the Report—Report of Finance Committee—Report of Committee on Uniformity of Meter Connections—Election of New Members—Amending Art. IV. of the Constitution—President's Address—Committee on President's Address—Appointment of Special Committees—Invited to a Seat on the Platform—Reading the Papers—Water Gas, by Walton Clark—Discussion—"Illumination vs. Candle Power,"* by A. C. Humphreys—The Relation of Intensity of Light and Visual Perception, by Ed. C. Jones—Joint Discussion—Utilization of Residual Products, by C. H. Nettleton—Discussion—Second Day, Morning Session—Naming Place for Next Meeting—Report of Committee on President's Address—Election of Officers.

End of the Baltimore Gas War..... 284

Complaints..... 285

The Market for Gas Securities 285

THE NEW YORK MEETING.

The American Association's preceding visit to the metropolis does not, when trusting to memory only, seem to have been made at as late a date as 1883, but a glance over the records reveals the fact that such was the case, and we are thus almost led to institute a comparison between the records made then at Teutonia Hall and those now being chronicled as the results of the '87 assemblage in Dockstader's. But such impulse is checked by the thought that as every tub must stand on its own bottom, so also should the doings of the separate assemblies be allowed to speak for themselves. Thus balked at the outset in the endeavor to enter fairly into the field of retrospect, we may, however, be pardoned for indulging ourselves so far as to assert that '87 would not suffer were the comparison instituted.

As a rule, the clerk of the weather is very kind to the inhabitants of our section of the country during the back end of October, when we are led from past experience to look for the most glorious days of the golden period so oddly known to common fame as Indian summer. But per-

haps at certain stages in the lapse of the years, the particular Indian who usually measures out the golden days in unstinted measure strays from his post with the result that a malicious substitute orders the reverse of that which would obtain were the good, though wandering, spirit in his accustomed place. Good Indian or bad, as the spirit in charge may have been, it is an undisputable truth that the evening preceding the 15th annual was a drippingly desolate one. New York city's approaches, especially those on the river fronts, are not very inviting at best, but when to their ordinary disagreeableness is added the discomfort that a sharp rainfall entails, then is the weary traveler's lot rendered a most unhappy one. However, personal discomfort did not prevent many of the delegates who intended to be first in the field from putting in an appearance at the place of rendezvous. Naturally enough the Sturtevant House, from its propinquity to the hall in which the sessions were to be held, attracted the larger number of the early birds; and by 9 P.M., or thereabouts, of Tuesday evening the halls and waiting room resounded with cheery greetings. Familiar faces beamed on every side, and all indications thus early favored the success of the New York reunion.

Wednesday dawned in gloomy manner, but the delegates were on hand in great force, and seemingly uninfluenced by the fact that rain was in the air. At the hour named for the opening of the convention Dockstader's presented a very different appearance from that which it usually takes on. The "minstrel boys" were supplanted for the nonce by men whose aim and purpose sought that advancement in their profession which is best brought about by open council and honest interchange of expression and opinion. We had counted on a larger attendance, not that it was not a numerically strong one as it was; but the Association's muster roll has been largely added to since the last gathering in New York, when the members present at least equalled, if not exceeded, in number those who responded to their names this year. A consideration of this brings to mind the fact—for it was made quite apparent during the discussion which followed the acceptance of Mr. Pearson's invitation to the Association to hold its next annual meeting in Toronto, Canada—that the sentiment of many favors a change in the date for holding the annual reunions of the Society. The objection has been urged to the present practice that it obliges the delegates to be away from their working districts at a time when the demands from their consumers are beginning to assume huge proportions. It seems to be thought that the last week in September, or at the latest, the first week in October, would better suit the convenience of the majority; still, in accordance with the Constitution of the body as at present modelled, the majority could not move off-hand (meaning without a year's delay) in the matter of a change without securing unanimous consent. This, it is almost unnecessary to say, could not be obtained. We also note that in the draft of the new Constitution submitted at this meeting by the Executive Committee it is proposed (see Sec. 34) to retain the 3d Wednesday of October as the initial meeting day. However, when the new form shall come up for consideration the objectors will be afforded ample opportunity to show their strength.

One particularly pleasing thing to the convention was the presence of three gentlemen, out of those whom it felt delighted to honor in the past with an election to honorary membership—Dr. Henry Morton, President of the Stevens Institute of Technology; Mr. R. P. Spice, perhaps as well

known to the whole gas world by his *sobriquet*, "The Hermit of Westminster," as by any of the other titles earned in connection with engineering pursuits, and whose annual visit to America to attend the Association's meetings is regularly and pleasantly anticipated; and Dr. E. G. Love, the clever and competent official gas examiner for the metropolis. Yet another distinguished visitor was present in the person of Mr. F. E. Barker, a member of the Massachusetts State Gas Commission, a body which has, by its careful and conservative action so far, demonstrated thoroughly the value of, if not the necessity for, having such a board of arbiters to intervene between the gas maker, the gas consumer and the bond maker. Of course, many faces were missed from amongst the gathering whom we would have wished to see—notably the sage of Indianapolis: but the roll call tells the story.

Once settled down to work, the discrimination of the veriest tyro in such matters would be sufficient to enable him to comprehend the fact that a master hand was on the gavel; and it is not at all too much to say that were it not for President Greenough's apt and firm rulings, some portion of the third day—set apart for guidance at the hands of the local Committee of Arrangements—would have to be devoted to a business session: that is, if the technical matters before the convention were to have been properly taken care of. The report of the Executive Committee was more than ordinarily interesting this year, chiefly because of the draft of the new Constitution submitted. We give it in full in our other pages, and presume it will receive that careful attention which the importance of its future effect on the Society calls for. Some of its provisions, notably sections 38 and 39, we are at first glance disposed to view unfavorably, because they seem to open the way to methods of procedure which might sometimes border on those of the star chamber order. It will be noted that three papers were read whose titles did not appear in Secretary Humphrey's final official notice. Although unanticipated, they were, nevertheless, completely appreciated. One of these, "The Use and Value of Coke for Generating Steam," by Mr. J. L. Hallett, of Springfield, Mass., was prepared in response to the Secretary's especial appeal for information of that description; while President elect Turner's "Purification Puzzles," aside from its technical value—and owing to the train of thought it opens up, to say nothing of the masterly manner in which the subject was treated, that value is very great—affords ample proof that his pledge* made to the '86 meeting was kept to the letter. The papers, as a whole, probably exceed in interest those hitherto read at any of the Association's gatherings, and where all are meritorious it would perhaps savor of bad taste to single out any for especial comment. Speaking simply for ourselves, we incline to the view that those which will be found of especial interest to the fraternity at large are contained in the manuscripts submitted by Messrs. Nettleton, King, McMillin, Humphreys, Jones and Hallett. However, those which do not appear in this issue will speedily be given to our readers, and they constitute a jury perfectly qualified to decide without fear or favor.

President Greenough's address is just what might be expected from a man who carefully weighs what he wants to say before saying it, and that style of measurement is much preferable to the one which consists of speaking first and then attending to the delicate matter of adjusting the scale-weights. Mr. Westinghouse will, with others interested in another direction as well, receive cold comfort from his candid utterances. In one case, however, we feel that we would be untrue to ourselves did we not dissent from his conclusions in regard to the Institute proposition now under consideration by a special committee of the Western Association. We fail to see wherein Mr. Egner's suggestion is not in every way superior to that proposed as a sort of substitute at the New York meeting. Paying no heed to the minor objection about the name selected, which may or may not be considered inappropriate according as individual fancy dictates, we venture to say there will be no difficulty in obtaining a score of working managers for the Institute, who could and would be trusted implicitly, if such a duplication were deemed necessary. In our opinion, all the whipping that can be devoted to it would not cause the Investigating Committee to even remotely answer the purpose for which it has been created. There is too wide a division of responsibility. We may be mistaken in this, but are yet with Mr. Egner. However, Toronto and '88 will develop something tangible, either for or against. The address is a vigorous one, and its lessons are many and valuable.

Those who have not attempted the task, strange as it may seem, can have no idea as to the difficulty of arranging for the organized entertainment of many people in the city of New York, at this season of the year especially. Countless visitors throng the hotels, and the suburban out-

lets are bleak and cheerless. Despite these drawbacks the local committee of arrangements were equal to the contract, and acquitted themselves in royal fashion. Such a long period of time has elapsed since the festivities of the occasion that any extended mention of them now would be rather tame. The first "independent" banquet of the Association was spread in Lyric Hall, by caterer Terhune; and his name is a sufficient guarantee that profusion and elegance signalized the *menu*. President Greenough played the role of entertainer with grace and tact, although at one time his wand of office looked rather awe-inspiring.

The excursion party who were to board the iron steamboat *Cygnus* at 10 A.M. of Friday, were somewhat inclined to doubt the pleasure of the trip, for the clouds were lowering and a rather stiff northwest wind reminded them that "it was an eager and a nipping air." However, the weather conditions righted somewhat before the start was made, and improved continuously throughout what turned out to be a delightful journey to the 180—of whom perhaps 50 were of the gentler sex—who participated in it. Leaving the foot of West 23d street the *Cygnus* made here way down the North or Hudson river to the sister stream whose broad and surging waters have been conquered by the noble pile known to all the world as the New York and Brooklyn Bridge, thence on and up to that famous retreat known as Blackwell's Island. Returning over the same course, entrance was made, through Buttermilk channel, to the Narrows, on past the forts, including dismantled Lafayette, reposing dark and grim in the path of the ocean voyager, and redolent with memories of '61. A few miles further on, and with Coney Island's sands glistening in the struggling sunbeams, the *Cygnus* deftly swung about, and ploughed her way once more to the beautiful Hudson. The return passage enabled the voyagers to become acquainted with Madame Liberty, who, from her lofty height on Bedloe's Island, holds out the light of hope. Then on up through the Hudson, amidst a bewildering change of scene, every succeeding feature of which seemed more beautiful than its predecessor. The hour was growing late, and that necessitated the order for a return to be made when Sing-Sing had been reached. Luncheon and dinner were served at appropriate times, and an excellent band of music enhanced the pleasure of the voyagers. In fact, when the dinner had been discussed, the music proved so irresistible that the "decks were cleared for action," and many couples were speedily engaged in paying active devotion to the goddess of the twinkling feet. The point of debarkation was reached in good time, and thus ended a most pleasant day—fitting sequel to a red-letter convention of the American Gas Light Association.

Effect of Carbonic Acid on Illuminating Power of Coal Gas.

Mr. C. W. Hinman, Gas Inspector for the State of Massachusetts, under date of Boston, Mass., Oct. 24, writes as follows:

I see in your last issue an article, by Jno. T. Sheard, originally published in the *London Journal*, on the "Effect of Carbonic Acid upon the Illuminating Power of Coal Gas." The article in question is a valuable one, and it gives a series of determinations of the loss of candle power arising from the presence of from 1 to 2½ per cent. of carbonic acid in the gas. Mr. Sheard's knowledge of the literature of the subject appears, however, to be somewhat limited, as he only mentions two or three experiments by Mr. C. J. R. Humphreys, on gas containing 1½ per cent. carbonic acid. Mr. Lewis T. Wright, some 30 years ago, made a series of determinations of the effect of varying amounts of carbonic acid on the light produced. Mr. Fred. E. Stimpson also investigated the subject. In my report to the Massachusetts Legislature for the year 1882 may be found the results of several experiments. Also Dr. Percy R. Frankland, in the *Jour. Chem. Soc.*, London, 1884, gives the results of mixing various amounts of carbonic acid with ethylene. As my own results are contained in a report which only a few gas men have ever seen, and which has never been republished, I may perhaps be pardoned for referring to the results. The gas, both free from carbonic acid and containing various quantities of it, was burned both from an Argand burner and from a slit steatite burner. The gas was in all cases burned at the rate best adapted to it, which was not far from 5 feet per hour. The following are the results:

Argand Burner.		
Carbonic Acid in Gas.	Loss of Light.	Ratio.
1.3 per cent.	2.3 per cent.	1.8
2.8 "	5.4 "	1.9
4.9 "	9.2 "	1.9
7.5 "	15.1 "	2.0
Slit Burner.		
1.4 per cent.	6.3 per cent.	4.5
2.5 "	12.4 "	5.0
3.9 "	16.9 "	4.3

The gas had an illuminating power of about 19 candles. If Mr. Sheard's results are calculated on the same basis as mine they give, with the Argand burner, the ratio of the loss of light to each per cent. of carbonic acid as 2.5, and with the open burner the ratio becomes 5.1; or he found carbonic acid to have a somewhat greater effect than my experiments indicated.

*The Charleston Gas Company suffered great damage from the earthquake shocks in that locality in '86. President Turner, having recited some of the losses incurred, closed the narration by saying, "Although badly wrecked, we propose to go ahead."

SPECIAL ENGLISH CORRESPONDENCE.

COMMUNICATED BY NORTON H. HUMPHRYS.

SALISBURY, Oct. 10, 1887.

Effect of Gas on the Binding of Books.—A Coal Gas Basis.—The Claus Process.—Advice to Gas Consumers.—New Filling for Coke Scrubbers.—The North of Ireland Association of Gas Managers.

Mr. C. J. Woodward, of Birmingham, has been trying some experiments with strips of leather, by exposing them to an artificially foul atmosphere, for a period of 1,000 hours. The impure atmosphere was obtained by burning a jet of gas in an unventilated fume cupboard in sufficient quantity to produce a temperature ranging from 130° to 160° F.; and the object in view, in submitting the leather to this slow cooking process, is to exemplify the effect of the products of gas consumption upon the leather bindings of books in public libraries. The most straightforward way of doing this would be to go to the libraries and examine the books, and if necessary to arrange for a series of experiments under ordinary circumstances. It is not the usual custom to put books for preservation in an unventilated hot closet, having an abnormally hot and foul atmosphere; and the phenomena obtained under such conditions cannot be accepted as any indication of that which actually occurs in ordinary libraries. Mr Woodward tested the strength of his strips before and after their hot bath, and found that they were weakened both as regards elasticity and breaking strain to the extent of 50 per cent. or so. They were also found to have absorbed an appreciable quantity of sulphuric acid, ranging from 1 to 3 per cent., presumably from the sulphur compounds present in the gas; but it is interesting to notice that the extent of depreciation in strength is in no way proportioned to the quantity of sulphuric acid absorbed. I make a special point of this, because it has always been usual among opponents of gas to quote "the sulphur compounds" as especially liable to cause corrosion of book bindings, hangings, curtains, etc., but Mr Woodward's experiments distinctly show that they are not all concerned in the matter. This question was well threshed out in the great sulphur fight of 1887, before a Parliamentary Committee, on the occasion when the Gas Light and Coke Company, and also the Crystal Palace District Gas Company, sought to be relieved from the sulphur clauses imposed upon them by Parliament, which limited the quantity of these substances allowed to be present in the gas under heavy penalties in default. The applications were opposed on behalf of the consumers, and no expense was spared on either side. A great number of expert witnesses gave evidence, in some cases illustrating their views by experiments performed before the Committee. The general evidence went to show that excessive heat and want of ventilation were the chief factors in producing the injury to property attributed to the sulphur compounds, and this view is distinctly supported by Mr Woodward's experiments.

A new system of selling gas has been originated by the directors of a small gas undertaking in Scotland, who have recently changed from coal to paraffine oil as their staple material. The oil gas is said to be of 60-candle power, and, of course, one result of introducing such a great improvement in photometrical value was a diminution in the quantity required. The consumers found that a less quantity of gas was necessary to produce the same amount of light. Under these circumstances, instead of directly announcing that the price of the gas would be increased in proportion to the increase of quality, some imaginative genius on the board hit upon the happy plan of selling according to a fictitious mode of calculation which he dubbed the "coal gas basis." Assuming that the oil gas was worth two and a half times as much as the coal gas, this convenient process consisted of multiplying the consumption, as indicated by the meter, by 2.5. It is beautifully simple, and the advantage of the "basis" to the directors of the gas company is obvious; formerly they received \$1.90 per 1,000 cubic feet, but this figure, under the magical influence of the "basis," becomes \$4.75 per 1,000 cubic feet. Unfortunately the consumers do not see matters in this light. They fail to appreciate the argument, and insist that gas sold at the price last named must necessarily be much dearer than the old coal gas; and they also object to having the "basis" forced upon them. I think that under any circumstances it would be difficult to raise the price of gas to the extent of 2.5 times, notwithstanding the fact that equal value may be given in quality. Consumers need instructions in the way of using such rich gas to the best advantage. But matters are not likely to be assisted by introducing roundabout ways of dealing, like the "coal gas basis," which only increase difficulties by creating suspicion and distrust.

A recent issue of the *Journal of Gas Lighting* contains an interesting article on the Claus system of purification, by Messrs. Heaton & Watts, the chemists who have superintended the experimental trial on a practi-

cal scale that has been conducted at the Winsor street gas works, Birmingham. In this system the gas, after being freed from tar, is treated in scrubbers or washers with caustic ammonia, separately and continuously prepared from gas liquor, with a regulated quantity of sulphur, and finally with the spent liquor from the ammonia still. In this way it is purified as completely as is possible by the usual process entirely by the use of liquids in closed vessels, whilst sulphur in the solid form, and other valuable by-products are obtained. The advantages claimed are, therefore, avoidance of nuisance—an important point in the case of gas works situated in crowded or near fashionable localities—some economy in labor, seeing that liquids are more cheaply moved about than solids, as they can readily be pumped from place to place, and some addition to revenue by means of the bye-products recovered. The gentlemen above named give an exhaustive description of the plant used, and conclude with an estimate of the cost, based upon their experience at Birmingham. The gross cost works out to 7.4 cents per ton of coal; but against this must be credited sulphur, ferrocyanide of potassium, and economy in the manufacture of sulphate of ammonia, which works out to 13.18 cents. So it will be seen that there is a clear profit due to the process of 5.78 cents per ton of coal carbonized. The estimate, however, is not complete. It does not include interest on plant, allowance for repairs and depreciation, or for the royalty that would have to be paid by other users. Taking these issues into consideration, it is too much to expect that it could be worked at a profit under ordinary circumstances; but at the same time there is no reason why it should not be cheaper than the ordinary dry process.

Mr. Veevers, of the Denton Local Board Gas Works, has issued a circular for the use of his customers, in which he points out that although the meter is usually correct, the majority of the consumers do not get the equivalent in illumination for the amount of gas they pay for. This state of things is brought about by the gas being burnt under improper conditions, the most common of which is excessive pressure. Having enlarged on this point, he passes on to notice the advantage of using a good automatic governor at the outlet of the meter, examples of which may be seen at the gas works, and proceeds to remark that ordinary burners require to be changed, in the interests of economy, about once a year. He warns gas consumers against the pretensions of hawkers who sell inferior burners at a high price, and announces that the best make of burners may be obtained at the gas works at cost price. Many efforts have been made of late years to instruct consumers. The example set by the veteran Mr. Rutter, of Brighton, who issued pamphlets for the use of consumers about half a century ago, has found many followers, but yet there remains much to be done. At the same time we may congratulate ourselves that there is a marked improvement in the methods of using gas. Consumers begin to recognize the intimate relation between the description of burners they use and the value they receive in return for the money they spend in gas.

At the recent meeting of the British Association Prof. Lunge described a new apparatus he has arranged for condensing or absorbing gases by contact with liquids. It consists of a tower scrubber packed with a special kind of tile. These tiles are flat, and so shaped that they may be packed in layers. They contain fine perforations about half an inch apart, and are so arranged that the holes in one layer baffle with those of the next. A small annular ridge or projection stands about one-eighth inch above the top surface of the tile, around each hole, and there are also ridges extending in parallel lines and at right angles, so arranged as to form a shallow cup or basin surrounding each hole, which retains a small quantity of liquid. The liquid descending through the holes drops upon the ridges in the layer next below, and is thus evenly distributed and diffused. If the holes are so small as to be plugged by the drops of liquid, a further advantage is secured. This form of scrubber may be commended to the attention of all who are experimenting with liquid purification, but it is obvious that the gas must be thoroughly free from tar before passing into it.

A gas managers association has just been formed in Ireland, under the title of "The North of Ireland Association of Gas Managers." Mr. E. Stears, of Lisburn, was elected as the first President, and Mr. J. Whimster, of Armagh (at whose works the first meeting was held), as Secretary and Treasurer. A committee of six was also elected, to manage the affairs. Fourteen of the gentlemen present entered their names as members, and Mr. Whimster was able to announce that eleven others had signified by letter their desire to join the Association in the event of its being formed. Two extraordinary members were also nominated. It was decided that the annual meeting should be held on the second Tuesday in August in each year. The subscription was fixed at 5s. per annum for ordinary members and associates, and half a guinea for extraordinary members. The committee was requested to prepare a list of

rules, and to submit the same to the members at the first general meeting which is to be held at Lisburn. The newly-fledged President and Secretary then proceeded to inaugurate their new duties in an appropriate manner, by respectively occupying the chair and the vice-chair at a social dinner. In the after proceedings, it is needless to add, the toast of the new Association was proposed and enthusiastically received.

For some few years past the gas managers of Ireland have recognized the disadvantage at which they were placed in not possessing a distinct Association, and various efforts have been made in the way of bringing about a meeting for the formation of the same. It remained, however, for Mr. Whimster to promote the successful gathering, on the occasion above mentioned. It should be observed that the business meeting was by no means a proceeding of mere routine. An animated discussion took place, which showed that the matter had been well digested by several of the gentlemen present. Altogether the Association has made an excellent start—quite as good as the Gas Institute and our English District Associations. It only remains to express a hope that the result of the meeting at Armagh may be the gradual development of a sound and healthy Association, that will serve as a source of wholesome instruction and benefit to its members for many years to come.

ITEMS OF INTEREST FROM VARIOUS LOCALITIES.

PUBLIC LIGHTING AT DETROIT, MICH.—The people of Detroit appear to be in a quandary over the lighting of their streets. They are far from being satisfied with the imperfect service, despite the steep figure paid for the same, rendered in the near past by the Brush Company, but they are not disposed to forego the arc system of illumination. The Brush folks, however, seem to think that "all things come to those who wait," and consequently are indisposed to reduce the figure (as to time or money) submitted by them to the authorities. The Detroit gas companies in the meantime have asked the Council to consider a proposition to readmit them to the public lighting field. Briefly stated, the gas men say: "If necessary, enter into a contract with the Brush Company to light the city for another year, at the expiration of which period we will be in the field with an electric plant. Then you (the city) will be in position to have, at least, whatever benefit attaches to *bona fide* competition." This proposition seems likely to shut the Brush Company out from a three-year's grip on the fund for lighting Detroit's thoroughfares. It might be said that some of the Detroiters want the authorities to purchase the local Brush plant and operate it on behalf of the public.

GETTING READY FOR THE WINTER'S WORK.—The Stacey Manufacturing Company is constructing two gasholders on the Water street property of the Fall River (Mass.) Gas Company. We understand that this construction will put an end to many a complaint indulged in of late years by the Fall River gas consumer, who seems to be somewhat crankier than even the average growler of his class. It appears that the old holders were inclosed with wooden housings, and that fact led some consumers to ask how it was "possible for them to obtain a good supply of gas when the Company employed barns for storehouses!"

PUBLIC LIGHTING AT MORRISTOWN, N. J.—After several months of delay the Morristown Council has decided on how that city is to be lighted for the ensuing year. Mayor Wertz, as the result of a special meeting recently held, was authorized to execute a contract with the Gas Company for a certain number of gas lamps at the rate of \$16 each per annum; also to contract with the electric light company for 12 or more arc lights, at \$120 each per year, and one (or more) incandescent lights, at the rate of \$17.50 per annum. Judging from the indefiniteness of the electric lighting portion of the agreement, it looks as if electricity might be called on to perform the lion's share of the illumination.

APPROACHING A TERMINATION.—If indications can be trusted the protracted Baltimore, Md., war of gas rates is about to end in peace and plenty. The Baltimore *Herald* (of Oct. 21) says in regard thereto: "There is now little doubt that the war between the Consolidated and Chesapeake Gas Companies is liable to be settled at any moment. Two days ago Mr. J. W. Hall, President of the Consolidated Company, went to Philadelphia, where he met President Benedict, of the Chesapeake Company. Yesterday the executive committee of the Consolidated held a meeting, and rumor had it that the session was called for the purpose of making the final arrangements for a settlement. Another important fact that tends to show conclusively that consumers will not long get gas at 50 cents per thousand is that both companies have withdrawn their canvassers. The rumors of the approaching settlement had the effect of making Consolidated stock very active, sales being effected at as high a figure as 63. Upon what basis the settlement will be made it is hard to determine, but the general supposition is there

will be an equal division of the business of the city between the two companies, and that the price of gas will be advanced to \$1.25 or \$1.50 per thousand." Springfield (Mass.) papers please copy. [An agreement has been reached.]

THE COST OF IT AT PARIS, ILLS.—We are informed that it costs the town of Paris at the rate of about \$4,000 per annum to operate its electric lighting plant.

IN PLACE OF T. B. CATHERWOOD.—Some time ago we had occasion to announce that T. B. Catherwood (who acted in the capacity of accountant to the Savannah, Ga., Gas Light Company), owing to irregularities, had been discharged. His place is now filled by Mr. W. J. Golden.

IT MIGHT HAVE BEEN WORSE.—The Winnemucca (Nev.) Gas Company's plant had a narrow squeak from destruction by fire about a fortnight ago. Prompt action, however, saved the citizens from the necessity of groping in the dark o' nights—for a time at least.

DOUBLING UP.—The Augusta (Ga.) Gas Light Company is about to double its gas making capacity.

ELECTRIC LIGHT IN SAN FRANCISCO, CAL.—According to the report of the local gas inspector the California Electric Light Company supplies the city with 16 masts—15 of these are 150 feet in height, each—which carry a total of 61 lamps of the nominal 2,000-candle power sort. Each lamp is paid for at the rate of 66 cents per night, the lights being in duty on 329 nights of the year.

A RETORT HOUSE ROOF COMES DOWN.—Shortly after midday of October 16, the stokers employed in the retort house of the Metropolitan station of the Consolidated Gas Light Company, of this city, were treated to a great surprise. The house is on the south side of 42d street, and is about 275 feet in length by 60 feet in width, the walls being perhaps 22 feet high. The roof frame, etc., is of the truss pattern, and, it is said, was constructed originally in 1861. It certainly looked substantial enough, and had been inspected in September last. The result of that inspection caused certain minor repairs to be made on the structure, which presumably put an end to all doubt concerning its stability. At the time noted above, however, the workmen, who were about to resume their labors at the end of the midday recess, were startled by an ominous cracking sound. Glancing upwards it was seen that the eastern end of the roof was swaying as if subjected to the influence of a sudden gust of wind. The trembling lasted for some seconds, thus enabling those furthest from the section first affected to escape into the yard. To employ the words of one who witnessed the occurrence: "The roof began to fall at the eastern end. About 30 feet of it came down in a lump, and then the impulse was slowly communicated from girder to girder and along the whole length of the structure until it was all down. This took several seconds, and it went down like a row of bricks set on end." Five of the employes were unable to make their escape, but strange to say all escaped fatal injury. While the house after the crash looked like a pretty bad wreck, a clean up showed that none of the benches suffered material damage, and the operation of gas making was not interrupted. Many theories have been put forth in explanation of the disaster, but these differ so widely that it is better, perhaps, at the present time not to mention any of them. Among the injured was Supt. W. B. Lundie, who, besides having a fractured leg, also suffered the loss of a portion of his scalp. His wounds were of a most painful nature, and necessitated his removal to the Roosevelt Hospital, the surgeons of which institution informed him that weeks would elapse ere he could emerge from their care. To make matters worse Mr. Lundie had previously arranged for a most important event, the latter being nothing less than his marriage to a most estimable lady, the day for the ceremony having been announced for Oct. 17. The fiat of the surgeons was smiled at by the sufferer, who said they might better have employed the word "days" instead of "weeks." Mr. Lundie knew what he was talking about, too; for on the afternoon of Oct. 24 he instructed the physicians to adjust his splint encased limb with more than ordinary care, because he intended to become a Benedict on that day. They demurred, but he insisted. Finally, his persistence conquered, and in a short while the courageous Superintendent, comfortably (at least in a measure) reclining on his bed, was carried down to a vehicle in waiting and driven to his home, where he was united in marriage to the woman of his choice. As a morning daily puts it: "Mr. and Mrs. Lundie are now on their wedding trip, and it is not to the hospital, either." A pretty determined man Mr. Lundie evidently is, and his action proves that love not only laughs at locksmiths, but at doctors, too.

IN NEW HANDS.—On Oct. 18 the entire plant of the Belvidere (N. J.) Electric Lighting Company was sold, at public sale, to Geo. F. Wiley, of Phila., Pa., by John Simerson, auditor. The latter acted in accordance with an order of the court under an attachment suit. The plant consists of

a complete outfit, the property being seized by the sheriff about six months ago, on the night the first trial for lighting the town was to be made.

ALL IMPROVEMENTS.—Something over a fortnight ago the Supervisors of the town of Bakersville, Cal., granted franchises for the operation of a street railway, a gas and electric light company, and a water works. Judging from this, Bakersville must be enjoying considerable of a boom. Bakersville is the capital of Kern county, Cal., and is located on the Kern river at a point close to the line of the old Visalia division of the Central Pacific Railroad. It is 300 miles southeast of San Francisco.

KILLED BY THE CURRENT.—On the morning of Oct. 18 a lineman named Borchert, in the employ of the New Orleans (La.) Telephone Company, was stringing a telephone wire through Lafayette street to the Exchange on the corner of Poydras and Carondelet streets. Everything progressed smoothly until Rampart street was reached, where it became necessary to cross a Brush electric light wire. No danger was anticipated from this wire—it was a small copper wire insulated, and supposed not to carry more than 100 volts of current. Instead of that it came direct from a Brush main line, and when the telephone wire was thrown over it Borchert, who was letting out the slack, received a shock which killed him instantly.

CONTRIBUTED BY THE GAS COMPANY.—The illumination of the city of Charleston (S. C.) during what is known as Festival Week was quite a success. At one time it was feared that such a verdict could not be rendered, but the public-spirited action of the proprietors of the Charleston Gas Light Company—who agreed to furnish gas for the festive illumination of those quarters of the city to which the plant of the electric light company did not extend—alone made it possible.

DID SOME OF THE MONEY GO TO HIS SHIRTMAKER?—The Leadville (Col.) Illuminating Gas Company has filed a complaint in the District Court against ex-Senator H. A. W. Tabor, the complainant seeking to recover the sum of \$43,000. It is alleged in the complaint that several years ago the Company, needing money, issued bonds for \$100,000, which were secured by the usual trust deed. These bonds were intrusted to Mr. Tabor, who at the time was President of the Company, with instructions to dispose of them and, with the proceeds, to settle its out-standing debts. Mr. Tabor sold the securities and settled with the Company's creditors. It is claimed that a balance of \$27,000 remained in the President's hands, which sum has not been turned into the Company's treasury. That balance plus interest is what the Company wants the ex-Senator to pay over.

INCORPORATED.—Articles incorporating the Francis Incandescence Gas Lamp and Regulator Company have been filed with the Recorder, St. Louis, Mo. The capital is fixed at \$20,000, and Messrs. M. Treadway, J. P. Richardson, J. L. Huse, Jos. Peters and H. T. Kleibacher are returned as stockholders.

IN WORKING ORDER.—The new electric light plant for the supply of Ash-tabula, Ohio, was started up on the evening of Oct. 18.

REFUSED.—In our last issue we mentioned that certain residents, whose premises were in proximity to the site chosen for a gas works by the proprietors of an opposition gas company, at Owensboro, Ky., petitioned the City Council to refuse the newcomers a building permit. The opposition was based on the ground that a gas works would depreciate the value of the remonstrant's property. The Council considered the petition on the night of Oct. 18, and it was determined not only to refuse the permit, but also to establish an ordinance prohibiting any gas company from erecting a works for the manufacture of gas within the city limits without first obtaining a permit from the proper authorities.

ELECTRIC LIGHT FOR CATSKILL, N. Y.—The Catskill Electric Light Company, to light the village of Catskill, has been incorporated. Capital, \$20,000. Trustees, J. H. Posson, W. H. Palmer and Eleanor Posson, all of Catskill.

A WORD FROM DENVER, COL.—The new plant hitherto spoken of by us as being in course of construction, has been fired up. The *Denver Republican* says that Bro. Fay's new property is complete and handsome. Work on the conduit in which the local electric light company proposes to place its wires is now underway. Perhaps the New York city subway commissioners might receive a useful hint or two about the matter they are supposed to have under consideration were they to visit the "Elevated City."

ELECTED DIRECTORS.—At a recent meeting of the stockholders of the Schuyler Electric Light Company, held at Middletown, Conn., the following were elected Directors: Messrs. J. M. Camp, H. Woodward, O. V. Coffin and S. H. Butler, of Middletown, C. E. Dustin, of Hartford, F. Foster, of Fitchburg, Mass., and C. N. Wayland, of New York.

PUBLIC LIGHTING, HOOSICK FALLS, N. Y.—At the mid-October meeting of the Board of Trustees of Hoosick Falls, the principal object discussed was the granting of a contract for the lighting of the streets by electricity. The bidders included the local Gas Company, J. W. Wakefield, of Portland, Me., and Messrs. Holmes, Loeke and Hurd. After a protracted session and many ballots the contract was awarded to the last named, and they bound themselves to have everything in readiness for the work in hand before Jan. 1st. Further than that the Trustees adopted a nominal 1,200-candle power arc as the standard, we are unable to say anything in regard to the conditions which bind the contractors.

HOW OFFICIALS ARE SELECTED AT WHEELING, WEST VA.—The Wheeling gas works are owned by the city, and are managed by a board of Trustees, the latter being selected every two years. The Board, of course, have the right to say who shall serve under them, and the result is that the political leanings of the Trustees cause changes to be made oftener than would seem for the best interest of the property under their care. With so much in explanation, the following letter received by us from a Richmond (Va.) correspondent will be readily understood: "The new Board of Trustees of the Wheeling Gas Works, comprising Messrs. F. P. Jepson, T. E. Lewis and H. Seamon, met on Oct. 18 for the purpose of selecting some of the officials to practically manage the gas plant for two years, beginning Nov. 1. These consist of Secretary, Assistant Secretary, Collector and Superintendent. Not much interest attached to the filling of the three first-named places, and the following gentlemen were chosen to perform the duties attaching to the different berths: Sec., A. J. Seamon; Assist., S. F. Faris; Collector, C. A. Reed. Now, however, came the real tug—the Board room was liberally sprinkled with the faces and forms of those prominent in Wheeling politics. Two years ago, or when a democratic Board was chosen, they found the Superintendent's position filled by Mr. Jas. M. Dillon, who was acknowledged to be a thoroughly capable man, in all respects save that of his politics. He knew how to run a gas works, and gave every satisfaction to the people for years; but the democrats wanted a man of their own faith, and replaced him in the person of S. M. Darrah, whose democracy was unquestioned. Not a word can be said against Mr. Darrah on the score of fitness; in fact his administration during the time he has been in office has given unqualified satisfaction. However, the political tide having once more turned, and as soon as the result of the last civil election was made known, the republicans made no secret of their intention to return Mr. Dillon to his old place. Well, they kept their promise. When the other berths had been filled by the selection of those named above, a ballot for Superintendent (only Messrs. Dillon and Darrah were placed in nomination) resulted in the election of Mr. Dillon, although Trustee Jepson voted for the retention of the present incumbent. Justice would certainly seem to be served by the action taken, and we must concede that Mr. Darrah, in any event, can have slight cause for complaint at the result. Still it would be better for all concerned if the Superintendency of the gas works was removed altogether from the field of political prizes, for it seems to me that the gas consumers want gas and not politics. In conclusion I submit that the Wheeling instance affords a good reason, as is advocated frequently by some enthusiasts, why the gas supply of a city or town should never be operated or controlled as a public measure."

GAS FOR MOORHEAD, MINN.—Some time ago we noted that the residents of Moorhead wanted gas, and that a project for the establishment of a plant was being considered. Now as Fargo, although located in Dakota Territory, is only one mile west of Moorhead, and as Fargo already rejoiced in the possession of a gas works, the proprietors of the latter proposed to meet Moorhead's gas wants from their mains. They applied to the Moorhead Council for a franchise, which was granted, that guarantees them the exclusive right to supply gas in the new territory for a period of 20 years. The connecting link (in the shape of a gas main) is now being buried.

IN CHARGE AT CHEYENNE, WYO. TER.—Mr. N. L. Maher has been for some time past in charge of the works of the Cheyenne City Gas Company.

THE DALLAS CITY (TEX.) BOOM STILL IN BLOOM.—A letter recently received by us from Mr. Wm. Enfield, Supt. of the Dallas City Gas Light Company, says, among other things: "The boom of last year shows no signs of collapse; in fact, if anything, we are busier than ever. Since coming here I have been obliged to double the capacity of the plant, and now we are working it to the limit, with every prospect of being speedily called on to double up once more. The electric light does not hurt, but has rather relieved us. Put it down that our people are not discouraged. Our new 110,000 cu. ft. holder works finely. The holder and tank are as tight as drums." Work never did frighten Bro. Enfield.

RESIGNED.—We are informed by Mr. W. H. Hopper that he, on Oct. 18, resigned his position as Assistant Treasurer (at Philadelphia) of the Ameri-

can Meter Company. Mr. Hopper's connection with the Company dates from 1870.

THE COST OF IT.—The building to house the plant of the American Illuminating Electric Light Company, of Jacksonville, Fla., according to the local *Times-Union*, is said to have cost \$1,200. A gas company would have saved that sum in construction, perhaps.

AT WORK.—The Hauss Electric Light Company, of Chattanooga, Tenn., expected to be in readiness to supply light yesterday.

THE PACIFIC GAS IMPROVEMENT COMPANY, of San Francisco, Cal., can supply a maximum demand of 1,500,000 cu. ft. per diem. Up to Oct. 1 the Company's main system comprised 67 miles of pipe. The old San Francisco Company's capacity is equal to a daily demand of 5,000,000 cu. ft., and it owns 220 miles of street mains. The salary and expenses of the California Gas Inspector (R. F. McCarthy) were returned for the year at \$1,857.75.

PERSONAL.—Mr. R. P. Spice, otherwise known to gas men as the "Hermit of Westminster," sailed for home on the steamer Umbria on Oct. 29.

PUBLIC LIGHTING, STOCKTON, CAL.—Mr. C. A. Campbell, City Clerk of Stockton, asks for sealed proposals, which will be received up to 7:30 P.M. of Nov. 14, for the public lighting of that city for a period of two years from Jan. 1, 1888. Four forms are submitted, viz.: First, for lighting the streets with gas, either natural or manufactured; second, for lighting with electric lights; third, for lighting with gas and electricity; fourth, with any material or substance other than those before mentioned. The "form" also prescribes that "if the contract be awarded to any person or persons not having pipes or apparatus already in place, the City Council may allow until the first day of April, 1888, for preparing themselves for the work, and the contract shall run two years from that date."

PLENTY OF ZIRCONIA.—Prof. Brooks, late State Geologist, says that zirconia is found in inexhaustible quantities, and easy of access and removal, in several sections of California. The most important deposits are located in the following sections: Arroyo Seco and Irish Hill, Amador county; Spring Valley hydraulic mine, Cherokee, Butte county; Picayune Flat, Fresno county; in the sands of the Novarro river, Anderson Valley, Mendocino county; and at Eagle Gulch and Rock Island, Plumas county.

CHANGE IN TITLE.—The publication hitherto known as the *Sanitary Engineer* now bears the title, *The Engineering and Building Record*. Mr. W. H. Brinckerhoff, C.E., has accepted a position on its editorial staff. We wish him every possible success in his new line of work.

ANNUAL ELECTION, MANSFIELD, OHIO.—At the annual meeting of the Mansfield Gas Light Company, and the Mansfield Electric Light and Power Company, the following officers were chosen: For the Gas Company, President, L. A. Strong; Vice-President, S. E. Bird; Treasurer, Jos. Hedges; Secretary, W. C. Hedges; Supt., G. S. Harris. For the Electric Company, Prest., S. E. Bird; Vice-Prest., J. B. Netscher; Treas., Jos. S. Hedges; Secy., W. C. Hedges; Supt., G. S. Harris. Judging from these lists, one might conclude there will not be much difference between the companies when it comes to a question as to which shall secure a lighting contract.

THE COMBINATION PLAN AT COLUMBUS, GA.—Messrs. T. E. Blanchard, A. Dexter, E. H. Jenkins, W. L. Clark and D. F. Wilcox—all of whom are interested in the Columbus Gas Company—recently petitioned the City Council for the right to erect and operate an electric lighting plant in that city. The required consent was granted, and the necessary steps are now being taken to have the plant ready for business on Dec. 1. The gas men intend to supply both arc and incandescent lamps. Three circuits have been arranged for, the first to be closed at 9 P.M.; the second at midnight; the third at 6 A.M. More work for Bro. Jenkins.

ELECTRIC ECCENTRICITIES AT NEW ORLEANS, LA.—Elsewhere we chronicle the death of a lineman, caused by a shock from an electric light wire. This occurrence was supplemented, at a later hour of the same day, by the following list of electric eccentricities: The roof of the St. Charles Theater caught fire from an electric wire; the hat store of Fox & Hire, and Redwitz's saloon, suffered slight damage from a similar cause; and the cornice of the building occupied by the "Chess, Checkers and Whist Club," as well as the gallery of Cassidy's Hotel were also singed. While the damage in each case were comparatively slight, the happenings, nevertheless, go to emphasize the necessity for watching the wires pretty closely.

IMPROVEMENTS ON THE STAMFORD (CONN.) PLANT.—Acting under instructions from Treas. Gay, Supt. Miller, during the past summer, carried out plans that have resulted in placing the Stamford plant in position to meet

the demand that will be made on it during the coming winter. An extension of 35 feet to the retort house enabled the placing of a new bench of 6's, and also guarantees room for a similar sample of benchwork next year. The Company intends to construct a gasholder (to have a capacity of about 60,000 cu. ft.) in the spring of '88. The Company's business steadily increases.

THE CANDLE POWER.—From the report of the local Gas Inspector, we learn that the illuminating value of the gas supplied by the San Francisco Gas Light Company averaged, during the month of September, 20.17-candle power. The same official reports an average of 20.35 candles for the gas furnished by the Pacific Gas Improvement Company.

PUBLIC LAMPS, CHICAGO, ILLS.—Chicago has 20,034 public lamps, of which 14,569 burn gas.

NO GASOLINE IN BUFFALO'S GAS.—A fortnight ago, when reporting the figures that had been submitted by the various lighting companies, in response to the Council's demand for proposals for the public lighting of Buffalo, N. Y., we noted that Councilman White thought the gas companies were addicted to the practice of "mixing gasoline with the gas supplied to the public lamps." In order to clear up the doubt the city chemist—Mr. F. P. Vandenberg—was instructed to determine whether or not the Councilman's charge was founded on fact. Mr. Vandenberg carried out the order, and reports that the gas supplied is fully up to the required standards of purity and candle power.

ELECTED.—Capt. J. B. Parrmore has been elected President of the South Florida Gas and Electric Light Company, of Orlando, Fla.

WELL!—Corporation Counsel O'Brien has rendered an opinion to the effect that the gas mains, whenever such conduits interfere with the electrical subways now in process of construction(?) in this city, must be removed by the gas companies.

IN FAVOR OF PLAINTIFF.—Something over a year ago J. M. Gordon entered into a contract with the Louisville (Ky.) Gas Light Company to take all the ammonia that would be produced in its works, the agreement to last for 5 years. At the end of the first year Gordon refused to continue, and the Company entered suit for damages. The case was tried in the United States District Court, before a jury, who rendered for the plaintiff, assessing the damages at \$4,500.

REORGANIZED.—The plant and franchises of the Middletown (Ohio) Gas Light and Coke Company, recently sold at public sale, were purchased by a syndicate of local business men. Organization was effected by the election of Simon Goldman, President, and Geo. N. Clapp was made Manager and Superintendent. We understand the Company's capital is \$24,000.

CHEAPER GAS FOR SAN ANTONIO, TEX.—Mr. R. C. Morton, Secretary of the San Antonio Gas Company, has notified "San Antone's" residents that, until further notice, they are to have their gas bills made out on the basis of \$3 per thousand. We think this is a reduction of 25 cents per thousand.

ONALASKA, Wis., is to be lighted with gas from the mains of the La Crosse Gas Light Company. These points are about 5 miles apart.

NEW GAS COMPANY.—W. L. Whitaker and associates have secured the exclusive right (to run 20 years) to furnish gas to the city and citizens of Texarkana, Ark. Capital, \$53,000. This place is the capital of Miller county. It is 145 miles southwest of Little Rock, and 222 east by north of Dallas, Tex. It is on the line of the T. & P. Railroad, and is the southern terminus of the St. Louis and Iron Mountain Road. Population, about 5,000.

AN ITEM FROM TREMONT, NEB.—The Tremont Gas and Electric Light Company is putting in a 50 light plant—lights to have an illuminating value of 2,000 candles each—of the American Company's type. It is intended to have the plant in operation by December 15.

It is claimed that Bob. Ingersoll is one of the incorporators of the Standard Gas Light Company, whose proposed field of operation is Cheyenne. Evidently the noted unbeliever is at last convinced that mining securities are risky properties, despite Col. Jno. Dell's experience to the contrary.

PUBLIC LIGHTING AT BUTTE, MONTANA.—The electricians have had control of the public lighting of Butte City for some time back, but at present it seems as if the Gas Company is to be granted a chance. The city is lighted now by means of 13 arc lights of the 2,000-candle power type, the total annual cost thereof being \$3,120—pretty high? At a recent meeting of the Council the Gas Company offered to supply 100 or more gas lamps (5-foot burners), and to light, extinguish, and clean the same for the sum of \$2.50 each per month—moonlight schedule, and contract to run for 5 years. The electricians offered to maintain 20 arcs—moonlight schedule, contract to run for 3 years—they to receive \$18 per month for each lamp. In the discussion that followed, Mayor Kenyon advocated a slight amendment—it referred to the locating of the gas lamps—to the Gas Company's proposition, which the latter accepted. The City Clerk was then instructed to draw up a contract with the Gas Company, the same to be submitted to the Council for ratification at a special meeting to be held on the next evening.

ONEIDA (N. Y.) citizens are complaining of the inefficient way in which the electric lighting of that place is being performed.

[OFFICIAL REPORT.]

Fifteenth Annual Meeting of the American Gas Light Association.

HELD AT DOCKSTADER'S HALL, NEW YORK CITY, OCT. 19, 20, AND 21.

FIRST DAY—MORNING SESSION—OCT. 19.

The Convention was called to order by the President, Mr. M. S. Greenough, of Boston, Mass. On motion of Mr. Slater the minutes of the last annual meeting were adopted as published in the JOURNAL.

ROUTINE BUSINESS.

The following applications for membership were received :

- | | |
|-----------------------------------|------------------------------------|
| Bierce, F., Memphis, Tenn. | Quinn, A. K., Newport, R. I. |
| Brown, E. C., Phila., Pa. | Russell, D. R., St. Louis, Mo. |
| Frost, E. I., New York city. | Snow, W. H., Holyoke, Mass. |
| Glasgow, A. G., Phila., Pa. | Stephens, G., Tarrytown, N. Y. |
| Howard, E., New York city. | Sriver, J. F., Montreal, Can. |
| Houston, W. B., Rahway, N. J. | Stacey, W., Cincinnati, Ohio. |
| Jackson, W. M., New York city. | Serafford, W. H., Bath, N. Y. |
| Krumholz, J., Buffalo, N. Y. | Tilden, W. D., New York city. |
| Lucas, Jr., P., Mt. Vernon, N. Y. | Wagner, L., Phila., Pa. |
| Lenz, E., New York city. | Whittier, C. R., New York city. |
| Morgans, W. H., Pontiac, Mich. | Ward, G. M., New York city. |
| Milsted, W. N., New York city. | Wilcox, W. K., Middletown, N. Y. |
| Murphy, J. M., Chicago, Ills. | Waldo, J. A., Boston, Mass. |
| Mooney, W., New York city. | Zimmermann, W. F., Pittsburgh, Pa. |
| Peters, M., Brockton, Mass. | |

The names were referred for consideration to a special committee consisting of Messrs. A. M. Norton, T. C. Cornell, and G. B. Neal.

ROLL CALL.

The following members were present :

Honorary Members.

- Prof. H. Morton, Hoboken, N. J. Prof. E. G. Love, New York, N. Y.
Robt. P. Spice, London, England.

Active Members.

- | | |
|-------------------------------------|-------------------------------------|
| Allen, A. L., Poughkeepsie, N. Y. | Cushing, O. E., Lowell, Mass. |
| Amory, Dr. R., Brookline, Mass. | Davis, F. J., Waltham, Mass. |
| Andrew, J., Chelsea, Mass. | Dell, J., St. Louis, Mo. |
| Atwood, H. A., Plymouth, Mass. | Denniston, W. H., Pittsburgh, Pa. |
| Baltimore, J., New York, N. Y. | Diall, M. N., Terre Haute, Ind. |
| Baumgardner, J. H., Lancaster, Pa. | Dickey, C. H., Baltimore, Md. |
| Baxter, I. C., Evansville, Ind. | Dickey, R. R., Dayton, Ohio. |
| Baxter, R., Halifax, N. S. | Dingee, F. A., Phila., Pa. |
| Baxter, W. H., Petersburg, Va. | Down, W. H., New York, N. Y. |
| Benson, F. S., Brooklyn, N. Y. | Edgerton, H. H., Phila., Pa. |
| Beal, W. R., New York, N. Y. | Edwards, G. B., New York, N. Y. |
| Blodget, C. W., Brooklyn, N. Y. | Elkins, W. L., Jr., Phila., Pa. |
| Boardman, A. E., Macon, Ga. | Faben, C. R., Jr., Toledo, O. |
| Borgner, C., Philadelphia, Pa. | Fay, W. J., Denver, Col. |
| Bradley, W. H., New York, N. Y. | Findlay, J. H., Ogdensburg, N. Y. |
| Bredel, F., New York, N. Y. | Flemming, D. D., Jersey City, N. J. |
| Brown, T. R., Philadelphia, Pa. | Floyd, F. W., New York, N. Y. |
| Bush, J. S., New York, N. Y. | Floyd, H. E., New York, N. Y. |
| Butterworth, W. C., Rockford, Ills. | Floyd, J. R., New York, N. Y. |
| Byrne, T. E., Brooklyn, N. Y. | Foster, T. G., Montgomery, Ala. |
| Cadwell, W. D., Nashua, N. H. | Fowler, J., Phila., Pa. |
| Cartwright, J., Poughkeepsie, N. Y. | Frost, W. H., Baltimore, Md. |
| Cartwright, M., Rochester, N. Y. | Gardner, J., Jr., Pittsburgh, Pa. |
| Cartwright, W., Oswego, N. Y. | Gates, F. W., Hamilton, Ont., Can. |
| Clark, Walton, Chicago, Ills. | Geggie, D. H., Quebec, Can. |
| Coggshall, H. F., Fitchburg, Mass. | Gerould, C. L., Brooklyn, N. Y. |
| Cole, T. W., Altoona, Pa. | Gerould, L. P., Manchester, N. H. |
| Connelly, J. S., New York, N. Y. | Gilbert, T. D., Grand Rap., Mich. |
| Connelly, T. E., New York, N. Y. | Goodwin, W. W., Phila., Pa. |
| Copp, A. M., Boston, Mass. | Gordon, J. J., Cincinnati, O. |
| Corbett, C. H., Brooklyn, N. Y. | Graeff, G. W., Jr., Phila., Pa. |
| Cornell, T. C., Yonkers, N. Y. | Greenough, M. S., Boston, Mass. |
| Cowdery, E. G., Milwaukee, Wis. | Gribbel, J., New York, N. Y. |
| Coyle, P., Boston, Mass. | Griffin, J. J., Phila., Pa. |
| Crafts, D. W., Northampton, Mass. | Hallett, J. L., Springfield, Mass. |
| Cressler, A. D., Fort Wayne, Ind. | Harbison, J. P., Hartford, Conn. |
| Curley, T., Wilmington, Del. | Helme, Wm., Phila., Pa. |

- | | |
|--------------------------------------|-------------------------------------|
| Hookey, G. S., Augusta, Ga. | Park, W. K., Phila., Pa. |
| Popper, W. H., Germantown, Pa. | Parrish, W., Seneca Falls, N. Y. |
| Horry, W. S., Phila., Pa. | Pearson, W. H., Toronto, Ont. |
| Humphreys, A. C., Phila., Pa. | Perkins, J. D., New York, N. Y. |
| Humphreys, C. J. R., Lawrence, Mass. | Pratt, John C., Boston, Mass. |
| Huntington, P. W., Columbus, O. | Prichard, C. F., Lynn, Mass. |
| Isbell, C. W., New York, N. Y. | Ramsdell, G. G., Vincennes, Ind. |
| Jones, E. C., Boston, Mass. | Richardson, F. S., N. Adams, Mass. |
| Jones, S. L., Phila., Pa. | Robinson, W. L., Uniontown, Pa. |
| King, E. J., Jacksonville, Ills. | Roots, D. T., Connersville, Ind. |
| Kitson, A., Phila., Pa. | Seaverns, F., New York, N. Y. |
| Kraft, G. W., Phila., Pa. | Sherman, F. C., New Haven, Conn. |
| Kreischer, G. F., New York, N. Y. | Slade, J., Yonkers, N. Y. |
| Lansden, T. G., Washington, D. C. | Slater, A. B., Providence, R. I. |
| Leach, H. B., Taunton, Mass. | Smallwood, J. B., Baltimore, Md. |
| Learned, E. C., New Britain, Conn. | Smedberg, J. R., Baltimore, Md. |
| Learned, W. A., Newton, Mass. | Smith, M., Wilkes Barre, Pa. |
| Lindsley, E., Cleveland, Ohio. | Spaulding, C. S., Brookline, Mass. |
| Loomis, B., Hartford, Conn. | Sprague, C. H., Boston, Mass. |
| Lowe, L. P., Phila., Pa. | Stanley, I. N., Brooklyn, N. Y. |
| Ludlam, E., Brooklyn, N. Y. | Stedman, W. A., Newport, R. I. |
| Mayer, F., Baltimore, Md. | Stein, E., Phila., Pa. |
| McCullough, E. H., Phila., Pa. | Stiness, S. G., Pawtucket, R. I. |
| McDonald, W., Albany, N. Y. | Taber, R. B., New Bedford, Mass. |
| McElroy, J. H., Pittsburgh, Pa. | Townsend, S. S., New York, N. Y. |
| McIlhenny, J., Phila., Pa. | Turner, T., Charleston, S. C. |
| McMillin, E., Columbus, Ohio. | Vanderpool, E., Newark, N. J. |
| Merrifield, P. S., New York, N. Y. | Warmington, G. H., Cleveland, O. |
| Merrick, S. V., Phila., Pa. | Watson, C., Camden, N. J. |
| Monks, R. J., Boston, Mass. | Watrous, V. S., Little Falls, N. Y. |
| Murphy, H., Sing Sing, N. Y. | Weber, A., New York, N. Y. |
| Neal, G. B., Boston, Mass. | Weber, O. B., New York, N. Y. |
| Nettleton, C. H., Birmingham, Conn. | White, C. A., New York, N. Y. |
| Nettleton, C., New York, N. Y. | White, W. H., New York, N. Y. |
| Norton, A. M., Nashua, N. H. | Willetts, C. A., Flushing, N. Y. |
| O'Brien, W. J., Phila., Pa. | Wood, A. C., Syracuse, N. Y. |
| Page, G. S., New York, N. Y. | Wood, G., New Bedford, Mass. |
| Gardner, Wm., Pittsburgh, Pa. | Zollkoffer, O., New York, N. Y. |

On motion of Mr. McMillin the regular order of business was modified so as to permit of the reception of reports of officers and standing committees.

REPORT OF TREASURER AND SECRETARY.

Secretary and Treasurer Humphreys presented the following annual report for year ending Sept. 30, 1887 :

<i>Receipts.</i>	
Initiation fees.....	\$410 00
Dues for year 1883.....	10 00
“ “ 1884.....	20 00
“ “ 1885.....	85 00
“ “ 1886.....	260 00
“ “ 1887.....	1,080 00
“ “ 1888, in advance.....	5 00
Sale of “Proceedings”.....	12 00
Interest.....	87 79
Total receipts.....	\$1,969 79
Cash brought forward from last year.....	2,202 59
Total amount to debit.....	<u>\$4,172 38</u>
<i>Expenditures.</i>	
Printing Vol. 7 of “Proceedings” and mailing same.....	\$918 35
Salary of Secretary and Treasurer.....	500 00
Expenses of Philadelphia meeting.....	81 35
Printing, stationery, postage, and sundries.....	234 96
Total expenditures.....	\$1,734 66
Cash carried forward to next year.....	2,437 72
Total amount to credit.....	<u>\$4,172 38</u>
Memo. of cash on hand :	
Deposit in South Brooklyn Savings Inst.....	\$1,194 71
“ Williamsburgh Savings Bank.....	805 60
“ Lawrence Savings Bank.....	368 08
“ Nat. Pemberton Bank of Lawrence.....	61 15
Cash in Treasurer's hands.....	8 18
Total.....	<u>\$2,437 72</u>
Due from members, including year 1888.....	\$1,915 00
Examined and found correct.	C. H. NETTLETON, } Finance A. E. BOARDMAN, } Committee.

The roll call for the year shows as follows:

Honorary Members.

Number on the roll Sept. 30, 1886.....	6
Admitted Oct., 1886.....	1
<hr/>	
On roll Oct. 1, 1887.....	7

Active Members.

Number on the roll Oct. 1, 1886.....	281
Admitted Oct. 1886.....	41
<hr/>	
	322
Resigned.....	10
Died.....	2
Number on roll Oct. 1, 1887.....	310
<hr/>	
	322

Deceased Members.—H. H. Fish, Utica, N. Y.; J. H. Walker, Sr., Tonawanda, N. Y.

The document was ordered to be placed on file.

REPORT OF EXECUTIVE COMMITTEE.

NEW YORK, OCT. 18, 1887.

To the Members of the American Gas Light Association: Gentlemen—Your Executive Committee would respectfully offer the following report:

The following papers, to be read at the present Convention, have been approved by the Executive Committee:

“Fuel Gas,” by Emerson McMillin, of Columbus, Ohio; “Illumination vs. Candle Power,” by Alex. C. Humphreys, of Philadelphia, Pa.; “Utilization of Residual Products,” by C. H. Nettleton, of Birmingham, Conn.; “The Advantages of Gas Companies Engaging in the Electric Light Business,” by E. J. King, of Jacksonville, Ill.; “Water Gas,” by Walton Clark, of Chicago, Ill.; “Development of the Half-Depth Regenerative Furnace and Some of the Results,” by O. B. Weber, of New York; “The Comparative Illuminating Power of Gas Purified with Lime vs. Oxide of Iron,” by C. W. Blodget, of Brooklyn, N. Y.; “Disadvantages Occasioned by Fluctuations of Candle Power in Gas Furnished to Consumers,” by Richard J. Monks, of South Boston, Mass.; “The Advantages of Regenerative Furnaces for Large and Small Gas Works,” by Fred. Bredel, of New York city; “Purification Puzzles,” by Thomas Turner, of Charleston, S. C.; “The Relation of Intensity of Light and Visual Perception,” by E. C. Jones, of Boston, Mass.; “The Use and Value of Coke for Generating Steam,” by J. L. Hallett, of Springfield, Mass.

Your Committee would recommend that at the present meeting the President's address be read after the reports of officers and committees.

At the last meeting of the Association the following amendment to the Constitution was offered, namely, to amend Article IV. by striking out the words “or engaged in industries relating thereto.” Under the rule, this proposed amendment was referred to the Executive Committee. Your Committee recommends that the amendment be adopted.

A resolution was also passed at the last meeting requiring the Executive Committee to submit to the Association such other amendments to the Constitution as might be thought wise. Your Committee, therefore, submits to the meeting the amended form of Constitution accompanying this report, as a basis upon which a more perfect Constitution can be built up.

In regard to the resolution upon the matter of Gas Commissions, which was considered at the last meeting of the Association and referred to the Executive Committee, your Committee would report that it is inexpedient to take action upon the subject.

Form of New Constitution Proposed by Executive Committee.

I.—Name.

1. The name of this Society shall be The American Society of Gas Engineers.

II.—Object.

2. The object of this Society shall be the promotion and advancement of knowledge, scientific and practical, in all matters relating to the construction and management of gas works, and the manufacture, distribution and consumption of gas.

3. The establishment and maintenance of a spirit of fraternity between the members of the Society, by social intercourse, and by friendly exchange of information and ideas on the before-mentioned subject matters.

4. The inducement and extension of more cordial and friendly relations between the manufacturers of illuminating gas and their patrons, based upon the mutuality of interests.

III.—Members.

5. The members of this Society shall consist of three classes—Ordinary Members, Honorary Members, and Associates.

6. To be eligible as an Ordinary Member, a person must be a president,

vice-president, director, secretary, treasurer, engineer, consulting engineer, or superintendent of a gas company, or an individual manager of a gas works.

7. Associates shall be persons holding a responsible position in a gas works, or persons whose pursuits constitute branches of gas engineering, or who are otherwise qualified to assist in promoting the objects of the Society.

8. Honorary Members shall be gentlemen whose scientific or practical knowledge in matters relating to the gas industry, and whose efforts and interest in that behalf shall recommend them to the Society.

IV.—Election of New Members.

9. Every application for membership shall be made in writing to the Secretary, indorsed by the Ordinary Members, or Ordinary Members and Associates, and must be accompanied by a statement in writing of the grounds of the application, and an agreement that he will conform to the requirements of membership if elected. The Secretary shall, thereafter, submit the application to the council to be considered, and, if approved by them, it shall be brought before the next meeting of the Society.

Application shall be made upon a printed form supplied by the Society, and shown in Schedule A, appended to these rules.

10. The preceding rule shall apply equally to any person soliciting admission as an Associate, application to be made upon a form, as shown in Schedule B, appended to these rules.

11. It shall be competent for any Associate to apply to the Secretary to be transferred from the class of Associates to that of Members. Such application shall be submitted to the council, who may, if the applicant is eligible to membership, recommend the transfer for approval at the next meeting of the Society, the application to be made on a form to be supplied by the Society, as shown in Schedule C.

12. Application for Ordinary Membership, or for Associate Membership, or for transfer from Associate to Ordinary Membership, must be received by the Secretary at least ten days prior to the meeting at which the application is acted on.

13. Honorary Members shall be proposed by the council, at a general meeting of the Society.

14. An applicant for admission to any class of membership, or for transfer from one class to another, must receive the votes of two-thirds of the members present to be elected.

15. If any person, proposed for admission to the Society, or for transference from the class of Associates to that of Ordinary Members, be rejected, no notice shall be taken of the proposal in the minutes.

16. Any persons elected to the Society, excepting Honorary Members, must subscribe to the rules and pay to the Treasurer the initiation fee before he can receive a certificate of membership. If this is not done within six months of notification of election, the election shall be void.

V.—Management.

17. The affairs of the Society shall be managed by the council, subject to the control of the general meeting.

18. The Council shall consist of the President, three Vice-Presidents, eight Ordinary Members, and the President or acting President of the preceding year. The Secretary shall also be, *ex-officio*, a member of the Council. Five members shall constitute a quorum.

19. The Council shall appoint from their own number, immediately after the meeting at which they are elected, a Finance Committee of three members.

VI.—Election of Officers.

20. The President, Vice-Presidents, Secretary and Treasurer shall be elected annually.

21. Four Ordinary Members of the Council shall retire each year.

22. All elections shall be by ballot.

23. The President and the four retiring Ordinary Members of the Council shall not be eligible for election the following year.

24. Previous to each annual meeting it shall be the duty of the Council to appoint a Nominating Committee of five members. It will be the duty of the Nominating Committee to present at the annual meeting a list of Ordinary Members, whom they recommend as office bearers for the ensuing year.

25. No member of the Council shall be eligible as a member of the Nominating Committee.

26. The Council shall have power to fill vacancies in its own body.

VII.—Duties of Office Bearers.

27. The office bearers shall assume office immediately after the meeting at which they have been elected.

28. The President shall take the chair at all meetings of the Society or committees at which he is present.

29. In the absence of the President one of the Vice-Presidents shall take the chair, and in the absence of the President and Vice-Presidents a Chairman shall be appointed from among the other members of the Council.

30. The duties of the Secretary shall be to take minutes of all proceedings of the Society, and of the Council, and enter them in proper books for the purpose. He shall conduct the correspondence of the Society, read minutes and notices of all the meetings, and also papers and communications, if the authors wish it, and perform whatever duties may be required in the Constitution and By-Laws appertaining to this department.

31. The duties of the Treasurer shall be to receive and keep all annual dues and funds of the Society, to keep correct accounts of the same, and pay all bills approved by the President or a member of the Finance Committee, and he shall make an annual report to be submitted to the Society.

32. The duties of the Finance Committee shall be to audit the books, accounts and statements of the Treasurer; to invest the funds of the Society, and to care generally for the finances of the Society, subject to the control of the Council.

33. The duties of the Council shall be to have the general management of the affairs of the Society, to designate the writers of papers at each meeting, and the subjects to be discussed, and to prepare for the meetings of the Society. The Council shall have the power to appoint, from time to time, a Committee of Arrangements from among the members to assist the Council in arranging for the meetings of the Society.

VIII.—*Meetings and Proceedings.*

34. The annual meeting of the Society shall be held on the third Wednesday of October of each year, at 10 o'clock A.M., at such place as shall be designated by the Society at the previous meeting.

35. At the annual meeting of the Society the order of business shall be: (1) The reading of the minutes of the last meeting; (2) the report of the Council on the applications for membership, and for transfer of membership; (3) the election and introduction of new members; (4) the address of the President; (5) the report of the Council on the management of the Society during the previous year; (6) the report of the Treasurer and of the Secretary; (7) reports of special committees; (8) election of officers; (9) reading of papers, and discussion on the same; (10) general business.

36. At other general meetings of the Society the order of business shall be the same, except as to the 5th, 6th, and 8th clauses.

37. The Secretary shall send notices to all members of the Society at least fourteen days before each general meeting, mentioning the papers to be read, and any special business to be brought before the meeting.

38. Special meetings may be called at the option of the Council, and the Secretary shall call a special meeting on the written request of 20 members. The notices for special meetings shall state the business to be transacted, and no other shall be entertained.

39. Thirteen members shall constitute a quorum.

40. All questions shall be decided by any convenient system of open voting, the presiding officer to have a second or casting vote when necessary.

41. Questions of a personal nature shall be decided by ballot.

42. Any member, with the concurrence of the presiding officer, may admit a friend to each meeting of the Society, but such person shall not take part in any of the discussions unless permission to do so be given by the meeting.

43. All papers read at the meetings of the Society must relate to matters either directly or indirectly connected with the objects of the Society, and must be approved by the Council before being read.

44. All papers, drawings, or models submitted to the meeting of the Society shall be and remain the property of the authors.

45. The Council shall meet before each general meeting of the Society, and on other occasions when the President shall deem it necessary. Of such special meetings reasonable notice shall be given by special call, in print or writing, specifying the business to be attended to. The President shall be requested to call the Council together on the written request of 5 members of the same.

IX.—*Privileges and Duties of Members.*

46. Every person elected as an Ordinary Member shall pay an initiation fee of \$10, which shall include the dues for the current year.

47. Every person elected as an Associate Member shall pay an initiation fee of \$10, which shall include the dues for the current year.

48. Every Ordinary Member shall pay annually, in advance, the sum of \$5.

49. Every Associate Member shall pay annually, in advance, the sum of \$5.

50. Honorary Members shall not be required to pay an initiation fee, nor annual dues.

51. No member who owes for two year's dues shall be entitled to vote, or to participate in the deliberations of the Society, or to receive a copy of the proceedings.

52. Any member may retire from membership by giving written notice to that effect to the Secretary, and the payment of all annual dues to date, unless released from said payment by a vote of the Council. Any member whose dues shall remain unpaid for a term of three years may be dropped from the roll of membership by a vote of the Council.

53. A member dropped from the roll for non-payment of dues may, upon paying the amount he owes the Society, be reinstated at the option of the Council.

54. Any member may compound for his annual payments by paying \$50 in one sum.

55. Each member of the Society shall be furnished annually, by the Secretary, with a copy of the proceedings of the Society and the Constitution, and also a list of the names and address of the members.

56. A member may be expelled from the Society by a recommendation to that effect made by the Council, at any general meeting of the Society. The vote shall be by ballot, and shall require two-thirds of the votes cast for its adoption.

57. An Associate Member will be entitled to all the privileges of the Society, except voting for and holding office.

58. An Honorary Member will be entitled to all the privileges of the Society, except voting for and holding office.

Amendments.

59. All propositions for adding to or altering any of the provisions of the foregoing Constitution shall be laid before the Council, who may bring it before the next general meeting of the Society, if they see fit, and the Council shall be bound to do so on the requisition, in writing, of any five members of the Society.

Discussing the Report.

The President—The recommendations of the Executive Committee will now be taken up separately and debated by the Association before action is taken upon them. The first recommendation is that referring to the proposed amendment to Article IV. of the Constitution. The Secretary will read Section IV. as it now stands.

The Secretary (reading)—“To be eligible as an Active Member a person must be a president, vice-president, director, secretary, treasurer, engineer, consulting engineer, or superintendent of a gas company, or an individual manager of a gas works, or a person practically skilled in the construction and management of gas works, or engaged in industries relating thereto.”

The President—It will be seen that the object of this amendment is to somewhat raise the qualifications which it is necessary to possess to become a member. The motion was made, I think by Mr. Stiness, that the words “or engaged in industries relating thereto” be stricken out; and this would render people who are simply engaged in industries connected with the profession ineligible as Active Members of this Association.

Mr. Harbison—Perhaps it would be well to further state that it is not the object of the Executive Committee to rule out from membership in the Association gentlemen engaged in industries connected with gas interests, for in the new form of Constitution proposed provision is made for *Associate* Members; hence gentlemen who are indirectly connected with the gas interests could become Associate Members, but not Active Members, although they can enjoy all the privileges of active membership save in the matters of voting and holding office.

The President—A request was made at the last session that the Executive Committee submit to the Association such other amendments to the Constitution as in their opinion might be wise. On the strength of that request the Executive Committee have reported a new Constitution altogether; and this proposed Constitution provides for two classes of members. Of course the new Constitution cannot be acted upon at this meeting; and there is no desire to do so. It will be presented to the Association, and will be considered by the members during the coming year. I presume it will be referred to the Executive Committee in the natural order of business, and next year will come before us for final action. The applications for membership which are now before the Association will not be at all affected by the passage of the amendment which is now proposed. They will come in under the old rule. But if this amendment is adopted, gentlemen who are simply engaged in some of the industries related to our business will not, next year, be eligible to

active membership. The Secretary will read the corresponding sections of the proposed new Constitution.

[The Secretary thereupon read paragraphs 5, 6 and 7, as published above.]

Mr. Slater—I suggest that action be taken now on the amendment to Article IV., and that we afterward take up the new matter.

The President—I made the explanation in order that the Association might understand what was the intention of the Executive Committee. The question now before the Association is on the proposed amendment to Article IV.

Mr. McMillin—May we not get into trouble by voting on that amendment, particularly if it is adopted? I believe it was the intention of the Executive Committee, in reporting this, not to exclude any applicants for membership at this meeting. Applications have been made and referred to the Committee, and that Committee has not yet reported. If we now adopt this amendment, and before that Committee reports, we may not be able to elect to membership some whose applications may be favorably reported upon.

On motion of Mr. Amory the amendment was laid on the table, to be taken therefrom when the Committee on Applications for Membership presented their report.

THE NEW CONSTITUTION.

The President now called attention to the draft of the new Constitution submitted by the Executive Committee. On motion of Mr. Harbison the matter was referred back to the Committee, they to report thereon at the next annual meeting.

GAS COMMISSIONS.

On motion, the recommendation of the Executive Committee in regard to gas commissions was indorsed.

REPORT OF FINANCE COMMITTEE.

The report of Finance Committee was received, read and ordered placed on file.

REPORT OF COMMITTEE ON UNIFORMITY OF METER CONNECTIONS.

Mr. Sherman, on behalf of the above-named Committee, read the following report:

“The Committee to whom was referred the matter of uniformity in meter connections respectfully recommend that the members of this Association adopt the unions of the American Meter Company, of New York city, as their standard. The Committee would take this time to express their obligations to the meter manufacturers for their samples of unions and valuable suggestions.”

A lengthy debate ensued on the report, the conclusions reached being the following: The report was tabled, and a motion (by Mr. Amory) was adopted to appoint a new Committee (to consist of representatives of the various meter manufacturing firms) to investigate the subject, the Committee to report, if possible, at the present meeting. In conformity with the resolution President Greenough appointed the following: Messrs. W. H. Down, New York city; W. W. Goodwin, Phila., Pa.; J. J. Griffin, Phila., Pa.; Wm. Helme, Phila., Pa.; J. B. Smallwood, Baltimore, Md.; and Nath. Tufts, Boston, Mass.

ELECTION OF NEW MEMBERS.

Mr. Neal, of Committee on Applications for Membership, presented a report favoring the election of those whose names had been submitted to them for consideration. The report was accepted. The Secretary was instructed to cast the ballot of the Association in favor of the election of the nominees. The latter were then welcomed to seats in the Convention.

At this point Honorary Member Mr. R. P. Spice (London, England) entered the hall, and, amidst loud applause, was escorted to a seat on the platform.

AMENDING ARTICLE IV. OF THE CONSTITUTION.

The President now reverted to the recommendation of the Executive Committee—it had been tabled to facilitate the election of applicants for membership at the present session—in regard to striking out the words “or engaged in industries relating thereto” from Art. IV. of the Constitution. On motion (Mr. Harbison) the recommendation was adopted.

PRESIDENT'S ADDRESS.

President Greenough then delivered the following address:

Gentlemen of the American Gas Light Association:—The first and most agreeable duty which falls to your presiding officer is that of welcoming you all to another meeting, and congratulating you upon the year's prosperity which the companies that we represent have almost without exception enjoyed. There are few industries in existence which for so many years in the past have afforded a safe investment to the cap-

italist and trustee. Whether this will be so in the future depends to a great extent upon the members of our profession here and abroad.

If we accommodate ourselves to the new demands which are now made upon us, and meet with cheaper or better light our various competitors in the race for public favor, then gas will continue to yield a fair profit to the genuine investor. If we do not, the consequences can easily be foreseen. The time has gone by when a gas company could charge such a price as would yield them the profit they desired and collect it without difficulty. The time has come when the price must be fixed to get the business and the profit looked for afterwards. By diligent searching, however, I think we shall be able to find it.

It is also a matter for congratulation that during the past year the inroads of death have been so small among us. We have left but few of our friends by the wayside in our march through life this year. With but two exceptions the Association remains intact, and I speak, I know, the general sentiment when I express my great and thankful satisfaction that our friend, Mr. Denniston, was not killed in that recent terrible disaster in Ohio. The gentlemen who have gone from among us, Mr. Fish, of Utica, and Mr. Walker, of Tonawanda, will be much regretted, and I trust the Association will take suitable action at this meeting in regard to them.

The second duty, which I shall try to perform, will be that of briefly reviewing various matters which have been brought prominently to our attention during the past year, and I shall then devote a few minutes to some subjects directly concerning our Association.

Undoubtedly the question which has been more than any other in the minds of most of us is the future of electric lighting, and the policy of gas companies with regard to it. We are all familiar with numbers of patents which have each promised to wholly revolutionize existing methods of gas making, and which gradually subsided like heaving waves of the sea, leaving no more effect upon our method of doing business than has been produced upon a rocky coast by the waves breaking against it. We have also seen an unreasoning terror of electric light seize with panic the holders of gas stock, and cause them to part for a low price with stock which to-day is more valuable than ever. As a result of these experiences the stockholder has grown, perhaps, too bold, and after an un-called for fear of the threats of his electric rival, he has not unnaturally passed into a defiant frame of mind, with entire confidence in the stability of his investment. It was, however, calculated to somewhat startle the strongest believer in gas to receive the circular from the Westinghouse Electric Lighting Company, which was sent a year ago to the gas companies of the country. In that document we were invited to abandon our business altogether so far as gas lighting was concerned, to turn our mains into conduits for fuel, and to furnish our customers with incandescent electric light as being the light of the future. Mr. Westinghouse is a man so well known throughout the world, of such indomitable energy and such financial success, that his name is a host in itself to the scheme he favors, and can command from his friends and followers the requisite capital to push it. You are to hear at this meeting a paper on the subject of the combination of gas and electric lighting, from a gentleman well versed upon the question, and I do not wish to say too much or I may be trenching upon his ground. You will also hear a paper on fuel gas, from one to whom we always listen with interest, so that that branch of the subject will require no detailed treatment at my hands. At the same time I should be unwilling to pass over this reference to the proposition of Mr. Westinghouse without expressing my disapproval of it. Far be it from me to underrate the value of the incandescent electric light. On the contrary, I am well known to have been favorably disposed to it for some time, and many gentlemen here will remember the criticism which I received at Providence, R. I., in 1886, for the advice* on the subject which I ventured to offer the New England Association. But there is a wide difference between supplying electric light to those who want it, and supplying nothing else. Before gas can be abandoned some other light must appear which is equally reliable and either better or cheaper. How are these requisitions filled by electricity? Better? yes; in some places. Cheaper? no; hardly anywhere. Equally reliable? not yet.

We hear a great deal of wiring new buildings for electric light, and we certainly see a great deal of it going into stores and theaters; but I fail to hear of buildings being erected without gas pipes also, nor is it customary to order out a gas meter when the wires are put up. People must have something to fall back upon which will not fail them. Perhaps the same may some day be said of electricity, but it will only happen when the wires are as securely buried and insulated as a gas main, and when a sufficient number of amperes are stored in various parts of the town, to prevent the lights going out in case of an accident to the

* See JOURNAL, Vol. XLIV., Mar. 2, 1886, p. 123.

generating station. It is perfectly true that people bear with some degree of equanimity an accident to their electric lights at present. They say that too much must not be expected of a new system, and cheerfully light their gas. Suppose, however, that the gas company abandoned its supply and turned over its pipes wholly to fuel, relying upon wires for light, and that then there should be the troubles which we occasionally have brought to our notice. I think the company and the public would both regret the change. So far the electric lamp has hardly penetrated the walls of private houses. From time to time I hear of some financial magnate who has put in a separate installation for his exclusive benefit, and I know of one station where a small number of neighbors are supplied from a storage battery into which the dynamo is continually working. Practically, however, the domestic lighting business is still untouched. To get this a light must be cheaply produced, which must either have less of that intense brilliancy which characterizes the ordinary lamp, or which must be so pleasantly shaded as to largely detract from its illuminating power. Still more important, however, is the question of reliability. It is all very well to attach as a novelty to a chandelier the glass globes containing the electric light, but when a steady and permanent use of a light is considered, it must be one for which gas can be abandoned. Now, this can unquestionably be done by the use of storage batteries upon a direct current, at a price. Whether it can be done at all upon an alternating current, such as the Westinghouse, remains to be proved. Perhaps so; but so far as I know it has not been. Upon a direct current it is feasible under certain conditions. In the first place, the storage batteries are very expensive, considering the uncertainty of their duration; and in the second, I am informed that they still are unsatisfactory. A battery should be like a gasholder. It should fill or empty itself as rapidly as may be desired, without injury or inconvenience; it should certainly give up in five hours the accumulations of the other nineteen, without any deleterious effects; but this, I am informed, has not yet been accomplished in practice. Probably it will be done—nothing seems impossible to an electrician, but when it is it will be at no trifling expense. In other words, putting aside the question of the quality of the light, which needs improvement, my conclusion is this—that if you want cheapness you lose reliability, and if you insist on reliability you lose cheapness. Now, some people want cheapness, some reliability, most people both. It has been said that literature is a good stiek, but a poor crutch—very well to help along, but bad to depend upon in a pinch. So with incandescent electricity.

If there is a demand for electric light of one kind in stores and of another in houses, I know no reason why the same gas company should not furnish both; but I think there are very good reasons why it should continue to furnish gas as well. And let it not be understood that when I talk of cheapness in regard to electric light I believe that it can be supplied as cheap as the same amount of light is furnished by gas in most of our larger cities. It can certainly be furnished cheaper than at first, and the use of high tension alternating currents with reducers has undoubtedly been a step in that direction; but I do not see my way to believing that it can as yet approach the cost of gas in this city, light for light, nor even that in towns where gas costs somewhat more than here. If there is an incandescent electric lighting company which sells its light at a price equivalent to gas at \$1.50 per thousand, and which pays dividends out of its earnings, I can only say that I have not heard of it. Gas, at that price, however, is unfortunately the exception and not the rule, and in very many of our smaller cities it is in the power of an electric lighting company to play the part of dog in the manger. It can prevent the gas company's making money without doing so itself. As in many other operations, the cost of running electric lights does not increase proportionately to the number in use, and it is, therefore, the policy of a small company to increase its business at almost any price, even at rates which not only exclude competition from gas, but which cannot return a new dollar for an old one. Under these circumstances the same alternative is presented as in the case of a competing gas company. The old one must settle or fight, and its policy must be governed to some extent by the character of the men who control the electric lighting company. If they act as did a company recently brought to my notice—put in a plant for \$30,000, and ask \$100,000 for it, the course of the gas company is plain; but if they are sensible men then I think a union of interests advisable. I am aware that this view is not universally held, but we are here for the purpose of comparing our ideas, and I trust that Mr. King's paper may elicit a full discussion.

Many members of our profession have been in hopes that they would be assisted in their business by an incandescent gas burner. The statement has been made, on good authority, that of the heat units in a gas flame only about 5 per cent. are utilized in light. I confess to having some doubts about the fact, but there is no doubt that if it is incorrect it

is only a question of percentage, and that undoubtedly there is much more light in a foot of gas than has ever yet been got out of it. The development of the Siemens and other high-power burners is a step in this direction, though by a different road. By utilizing some of their own waste heat they greatly develop brilliancy; in fact, a brilliancy so great as to make the light unsuitable for domestic lighting. It has been, then, in an attempt to get the same amount of light from less gas, and not more light from the same amount of gas, that the work has been done that has attracted so much attention, both here and abroad, during the past six months. A steady light, almost white, producing much less heat than an ordinary gas flame, perhaps because only half the amount is burnt, seems a very attractive investment and a very powerful ally; but an examination of all the facts is sure to greatly dampen any premature enthusiasm.

It has been found in the Welsbach burner that the light, though beautiful when the incandescent mantle was new, deteriorated rapidly, and it was not very long before the gas with which it was heated yielded hardly more light per cubic foot than could be obtained from ordinary burners. It was also found that the mantle was so extremely friable as to render its domestic use almost out of the question, and as a result of these two radical defects it has practically been a failure in Germany, except that in Vienna it can be seen in limited use. It is fair to say that some of the people interested in this and kindred burners admit its defects, and are busily experimenting with a view to their removal; and when we remember how boundless are the limits of human ingenuity, and against what seemingly insurmountable difficulties our electric rivals have successfully struggled, it would be a foolish prophet who would undertake to say what can or cannot be done in this direction. It has become evident that success in this business means a fortune to all concerned, and many brains have been set working at it. Without much faith in the present burners on the market, I am not without some hope of the future; and when the day shall come that an incandescent gas burner shall burn 1,000 hours and still give a light of 8 candles per foot of gas, and that with this shall be combined a toughness which shall defy ordinary jars, then I shall feel that the gas companies have really found a friend.

In this connection also should be mentioned the efforts of Mr. Lowe, Mr. Fahnehjelm, and others, to utilize for incandescent light the heat-giving powers of pure fuel gas. Personally I have grave doubts about the success of such a gas, both on economical and sanitary grounds. I may, however, be wrong. The fuel of the future may turn out to be artificially-scented hydrogen and carbonic oxide, at least in factories; and if this shall prove to be the case there will certainly be a great opening for somebody who shall succeed in satisfactorily meeting the demand for cheaper light as well as heat. Whether it has yet been met or not by the inventions now on the market I am not prepared to say; but I confess to considerable skepticism at present.

There is only one more practical question on which I wish to speak. That is regenerative furnaces. It is a subject which will be discussed in two papers at this meeting; but I wish to express my opinion to the effect that the tendency is to spend less money to save waste heat. Since the attention of engineers has been called to the possibility of heating retorts with ever-decreasing percentage of fuel, they have steadily persevered in that direction, piling up ever-increasing quantities of tile, and making the systems more complete, but at the same time more complicated. Every additional air flue brought in close contact to the outgoing gases for the purpose of extracting heat from them furnishes another opportunity for leakage also; and nothing can be more exasperating, as well as costly, than the failure of elaborately constructed settings to do their work. Suppose that in a comparatively simple system the percentage of fuel is not over 25 per cent. by volume or 17 by weight, and that in an elaborate setting it is cut down to 12, the cost of one being double that of the other, then it is apparently a question only of the value of fuel in each locality. But if the simple system works more reliably than the other, and with the exercise of much less care and intelligence, then I think another factor is introduced which is well deserving attention. It is probably the case that this audience contains men who can assure us of the entire success in their works of the most elaborate systems yet devised; but I think that if human nature were as willing to avow its failures as its good fortunes, they would be outnumbered by other men who would tell a totally different story. A very little thing can spoil any system yet invented. Only the greatest care can insure the perfect construction and working of a first-class regenerative setting. I was in Europe for a short time this summer, and visited one day one of the largest stations on the Continent. The engineer informed me that they had used there several of the best systems of elaborate firing with good results. He also said that they had used one of the unpatented

systems of half-regenerative work with so great comparative success that he doubted very much their building any more of the other kind. This of course is only a straw showing how the breeze is blowing on other people as well as myself, but as such it is worth nothing; and I am inclined to the opinion that the furnace which will eventually come into general use will be one which does not aim at the highest possible results.

The number of new processes for making gas which are devised by inventive and not too scrupulous men has become so great that it is no wonder that interest has been taken by the managers of so many companies in the formation of what Mr. Egner has tentatively christened by the name of the Gas Institute. He has called my attention officially to the scheme, that I might recommend it, if I saw fit, to the favorable consideration of this Association. Upon mature reflection I am unable to do this; first, because I doubt very much its satisfactory working, and, second, because if combined action is advisable for the gas companies I think it can be obtained in a simpler and less expensive way. I think also that the name proposed for the enterprise is not a happy one. It would, I think, be much better to select one which had not already been chosen by the largest Association of Gas Managers in the world, to describe an institution so wholly different from that which it is now proposed to establish. The name, however, is of minor consequence, though I trust some other one will be selected if the scheme proposed should become an established fact.

Granting, then, that combined action by gas companies is advisable is there no way of obtaining it save by the appointment of a high-class expert and a corps of assistants, and their establishment with offices and laboratory in Washington or elsewhere? If this expert is to be of value, his judgment must be of the best, and his character so high that no possible suspicion may rest upon him of possessing interested motives when he recommends or disapproves of any particular scheme. There are such men to be found in this country, of course; but they are all busily engaged at good salaries, and I think it would be by no means easy to induce one of them to leave his present assured position and take at any reasonable salary a place of which the permanency seems so dubious, for I doubt there being business enough to occupy a man for more than half his time; and I do not believe that the plan if put in operation would prove sufficiently profitable to gas companies to induce them to subscribe for many years.

I think, however, that by the medium of this Association the same result may be obtained, and in a better way. The plan which I would suggest would be the election of a permanent Investigating Committee, who should be nominated after careful consideration of localities, and who should be assisted when called upon to act by such of their neighbors as should put their names on the Secretary's list as willing to serve as volunteers. Let us suppose that Mr. Slater was the New England member, Mr. Wood the New York, Mr. McMillin the Ohio, or anybody else you please. Suppose also that myself and a dozen other gas engineers of New England had signified our willingness to assist Mr. Slater whenever called on. Suppose, again, that the manager of some town in our neighborhood was approached by the representative of some patent process, valuable or otherwise, but on which he is unwilling to trust his own judgment. He calls upon Mr. Humphreys, who refers him to Mr. Slater. If Mr. Slater is himself in doubt, he calls in turn upon such of the nearest volunteers as he desires, and they jointly make an examination of the process, make their report to the manager of the gas company interested, a copy of it to the Secretary of this Association, and draw from him the amount of their expenses incurred. Transfer the locality to New York or Ohio, and with different people a similar scene would be enacted. In this way the member of this Association in need of advice would not only get the best to be had in his neighborhood, but the Association would also get at the end of the year a valuable and interesting mass of information, from which a useful report might be extracted. The expense might be \$500 to this Society, though I should doubt it. If it were more it might be necessary to raise the assessment a trifle, if the value of the plan did not increase our members sufficiently to counterbalance it. As to serving on the committee, I think it would not be difficult to find candidates. Every man wishes to keep posted, and is desirous to learn about any new plan of making, distributing, or burning gas better. The number of occasions which he would be called upon would probably be small, and, I think, he could well afford the time. The number of volunteer aids whom he could summon would be, I think, nearly that of the Association.

I commend, then, this plan to the committee which I presume will be appointed to consider the President's address. Although in a crude form, and perhaps not fulfilling every requisite as a substitute for Mr. Egner's, I think it can be whipped into such a shape as to substantially do the work desired.

It is not remarkable that a demand should exist for educated assistance from the managers of smaller companies, for it is the experience of every person who has to do with engaging such, that it is hard to select, at the salary which can be paid, men who are competent to attend to all the varied details of a gas manager's work.

Although our large technical schools in Hoboken, New York, Troy, Boston and elsewhere are annually turning out scientifically educated young men, yet few of them know anything worth mentioning about gas; and when called upon to choose between the practical gas maker who works by rule of thumb, and the man of science who knows nothing in particular of the gas business, the employer is sure to select the former. Now, if there is any profession in the world which needs educated brains it is ours; and yet there are not enough of them in it. The amount of money invested in our business exceeds, I believe, that in any other except railroads, and yet its management is largely in the hands of men who lack a strictly technical education.

Often have I regretted myself, when listening to some glib scientific talker, that my education had not been thorough enough to enable me to detect what I believed to be his errors. A perfectly equipped gas manager should be both engineer and chemist, and besides that should have that technical knowledge of his profession for which many years of experience are the best teacher, but which a hard course of study can, to some extent, replace. When it has been sufficiently realized by the public that there is money in it, then very likely a special course may be given in some technical school, but at present I doubt that it would be appreciated, and I have been turning over in my head the possibility of some similar scheme to that adopted by the association of London Guilds. These ancient bodies have joined together for the purpose of technical examinations, not only for the trades which they once represented, but also for others. They do not teach, they simply examine; and workers in every industry come to London to get, or fail to get, a diploma, which they can show anywhere as a proof of their efficiency. Among the other examinations held is one for the office of gas manager. It is held by Mr. Robert Morton, formerly Engineer of the London Company, and the papers are prepared and examined by him. It is by no means easy to pass, and a considerable number of those offering are rejected. A young man who should come to me with a certificate that he passed with honor would impress me in the same way as would a young physician. His natural common sense could not, of course, be determined by any examination, and his information would be increased by a little experience; but a man possessed of thorough theoretical knowledge acquires experience rapidly. If there were some institution in this country of high repute which would take up this matter, I think very few holders of its diplomas would find themselves long out of work. I have nothing to suggest yet, for my only effort in this direction has been but a failure; but perhaps something may occur to one of my hearers from which results may eventually grow, and with that hope I commend it to your thoughts.

Among the other papers which we shall listen to at this meeting will be one on water gas. Although I know nothing of its contents we shall undoubtedly be interested in hearing it. Because this Association was founded by representatives of the older and more conservative companies, and because many of our members are still skeptical of some of the virtues attributed to water gas, yet we are all of us open to conversion. I probably am reputed myself to be as stubborn an opponent of it as there is, but I am none the less bent upon acquainting myself with the details of every new process brought out—its advantages and its weak points. Although the merit of economy can in many places be no longer claimed, yet some most ardent objectors to its use have received a change of heart owing to the influence of the Knights of Labor. No company can tell when they may be forced into its use, either wholly or as a supplementary system; and with this possibility before us I know no better place than the meetings of this Association to discuss all questions pertaining to the various processes. If the enthusiastic adherents of water gas—first, last and always—insist on withdrawing from their benighted fellows and getting up an association of their own, of course, the rest of us cannot help it; but I am sure I speak the sentiments of this body when I say that we should regret their action, and no matter where they go, or what society they found, I doubt their ever finding more interested auditors than here.

One thing more before I close. One of the weaknesses of human nature is a desire for decoration, and one of the evidences of this fact is the way in which most organized bodies take pleasure in ornamenting themselves with badges. To provide a simple and yet tasteful emblem of membership is always a tax upon the ingenuity and the pockets of those who arrange our meeting. If it is the desire of the Association to continue the custom of wearing something at our annual gatherings by

which members can be distinguished from outsiders, then I would suggest that a committee be formed to whom shall be committed the preparation of designs for a permanent badge, and that they be requested to submit these designs to the Secretary, with estimates of their cost, and that he then take the sense of the Society as to the one to be adopted, and order for the next meeting that number which the individual members agree to take and pay for. The only real necessity for conspicuous badges is upon the persons of the Committee of Arrangements at our annual excursion, and perhaps upon our Secretary. These might be easily provided. The rest of us can use some simple decoration, emblematic of our profession, and which I have full faith that we have among us sufficient ingenuity to design.

Gentlemen of the American Association:—"United we stand, divided we fall." The man who manages the business of his company, relying solely upon his individual experience and intelligence, can never keep up with the times. It is only by imparting to each other the results of our efforts to do better, no matter whether successful or not, and putting all our information into a common fund, that we can expect to prosper in the struggle before us. Hundreds of millions of dollars are invested in the business we represent, which it is our chief aim to protect. Nor can I better conclude than by reiterating my belief that if we are true to our duty the supply of gas will continue to be the chief source of modern light, and will yield a safe profit to the judicious investor. Strong in this opinion, I feel, of course, a firm confidence in the future of this Association, and a great desire for its prosperity.

COMMITTEE ON PRESIDENT'S ADDRESS.

Capt. White moved that a committee of three be appointed to consider the President's address, and report to the Association recommendations respecting such matters as are contained in the address which they might deem of special interest to the Association. The motion prevailed, and the Chair appointed as such committee Messrs. R. B. Taber, A. E. Boardman and G. G. Ramsdell.

APPOINTMENT OF SPECIAL COMMITTEES.

The following special committees were appointed: *On Nomination of Officers*—Messrs. F. C. Sherman, A. C. Wood, T. G. Lansden and W. A. Stedman. *On Place for Holding Next Meeting*—Messrs. W. Clark, D. H. Geggie, and T. G. Lansden.

INVITED TO A SEAT ON THE PLATFORM.

Mr. Harbison—Mr. Barker, a member of the Massachusetts Gas Commission, is with us. I suggest that he be requested to occupy a seat on the platform during the meeting of the Association.

The President—We shall be glad to have Mr. Barker take a seat on the platform.

Mr. Barker—Thanking you, Mr. President and members of the Association, for the courtesy you have been pleased to extend to me, I trust I may not seem discourteous if I ask to be excused from appearing on the platform. I can assure you that I am very much pleased to be here. We have come to look upon the meetings of this Association with a great deal of interest; and I am sure that my associates in the Gas Commission would be pleased to be present with you were they not detained by other engagements. (Applause.)

READING THE PAPERS.

The President called upon Mr. Walton Clark to read his paper on

WATER GAS.

Mr. Clark read the following:

There are before the American gas public many systems of water gas making. As to their individual peculiarities and merits or demerits, I have nothing to say here. I desire simply to give to the Association some of the conclusions to which my efforts after economy in water gas making have brought me, hoping they will be of use to some member about to enter this comparatively new branch of our business.

The possible economies may be grouped under two heads, entitled respectively, plant construction and operation. Granting that a proper design has been selected there is little to be said about construction. As in coal gas or any other manufacturing plant, so in water gas the apparently cheap is often the really dear, and the saving of dollars in construction may result in the waste of eagles in operation and repairs. The importance of a good construction in water gas plant is even greater than coal gas, because every portion of the apparatus is necessary to the manufacture. A coal gas works can lay off a bench for repairs at almost any time, without danger of landing the holder. With a water gas plant, except in the largest works, where they may be in duplicate, all repairs in the busy season must be made in the shortest possible time—for the night's supply of gas depends upon one generator; hence the importance

of first-class construction and readiness of access for repairs can hardly be exaggerated. There is no difficulty about constructing a plant which will need no repairs extensive enough to cause any delay during the winter, but it takes more iron and brick than another may which will make as much gas per day while in operation, but is liable to fail at a critical time. The take-off pipes are subject to occasional stoppage from careless working, and it is important that they should be put up with crosses and hand plates. All parts of the apparatus, in fact, should be made easily and quickly accessible by the use of plates and doors.

In locating a generator the most important point to be considered is the ease with which coal can be handled to it; yet it is one which must yield in part in extensions of old works to the location of the boilers. When an entirely new plant is erected the generator is best located where the handling of coal to it and ash from it will be easiest, and the rest of the plant made to conform. A generator requires either a cellar or a firing floor, and the coal or the ash must be elevated, unless the works are on rising ground, where one may be wheeled in and the other out without elevation. Unless the necessity of using an old building with a low roof, or some other local complication arises, I should not hesitate to adopt the elevated firing floor. The cost of raising the coal is slight, and the advantage of a well ventilated and lighted clinkering floor is great.

Under the head of operating expenses are three important items, viz., fuel, oil and labor; and upon the way the first is manipulated will depend in great part the cost of purification.

As the boilers, engines and pumps of a water gas plant have no features distinguishing them from those in use for other purposes, I will not consider them; therefore the first part of the apparatus to be noticed in connection with fuel economy is the blast pipes. All blast furnace experience shows the importance of having them large with long bends. On this point I have no comparative figures, but it is self-evident that reduced resistance to the blast will result in reduced consumption of fuel under the boilers.

Passing to the generators the question meets us—and upon it there has been, and may still be, a difference of opinion—shall the fuel bed be deep, five feet and upwards, or shallow, three feet and under? One objection to a shallow bed is that there is danger that an opening in the fuel, or a heavy clinker, will so far reduce the available depth of hot carbon that steam will escape undecomposed, or converted only to carbonic acid and hydrogen. Many experiments have convinced me that the possible rate of make of a certain standard purity (freedom from carbonic acid), or the degree of purity with a certain rate of make, is less with a shallow than with a deep fuel bed. Steam in the presence of incandescent carbon is decomposed, the oxygen uniting with the carbon. In the presence of an excess of oxygen carbonic acid is formed, to be converted into carbonic oxide by further contact with hot fuel. The larger part of the carbonic acid is almost immediately converted, but a certain quantity requires further contact, and the last portion, being more diluted, requires more depth of fuel for its conversion than any other equal portion. Experiments have shown me that the best gas is made at the beginning of a run, or when the depth of hot fuel was greatest. From these experiments, all made with apparatus on a working scale, I have come to the conclusion that a deep bed of fuel is desirable. One, and the principal, objection known to me is that in blasting the escaping gases from a deep fuel bed will be almost entirely nitrogen and carbonic oxide, the latter carrying off more carbon than would the carbonic acid made with a less depth of fuel. Where there are, as in making carburetted water gas, opportunities of utilizing the carbonic oxide to heat a fixing chamber, superheating steam, or preheating oil or blast, this objection disappears.

It is obvious that the arrangement of grate should be such as to bring the blast and steam into contact with every possible piece of fuel, and that there should be no ledges or offsets upon which coal could lodge away from their direct action. Fuel in such positions will gradually burn away in the eddies made by the blast, but will aid little in the manufacture of gas.

In burning the producer gas in the fixing chamber or superheaters, I often find that too much or too little air (generally the former) is admitted. Either will result in loss of heat, and delay in bringing the vessel to a proper temperature. The perfect point is where neither free oxygen nor carbonic oxide is present in the escaping gases; but it takes a chemical test to determine this. The practical way is to admit just air enough to keep the blue flame from showing at the outlet.

The introduction of steam into the generator at as high a temperature as possible is of advantage in two ways; it restores to the generator some of the heat given off in blasting, and prevents in part the quenching of the hot fuel with the consequent shortening of the period of gas making.

An extensive experiment with a cupola blasted with a jet blower, has shown that the amount of ash and cinder taken from it, when using steam at about 300° F., was 50 per cent. in excess of the amount taken from the same cupola, doing the same work, with steam at 650° F., about. As the ash in each instance must have been the same, the excess in one case must have been due to fuel quenched by wet steam.

The benefit derived from using superheated steam was in part neutralized by the fact that the generator required clinking twice as often, with a consequent loss of time and consumption of fuel for heating. Experience has convinced me, however, that the advantage is decidedly upon the side of hot steam. Mr. Carroll, of New Orleans, La., has made many experiments upon this point, and he agrees with me. Several months' running of two sets of water gas apparatus standing in the same building, and exactly similar, except that one had steam superheaters, showed a saving of two pounds of fuel per 1,000 cubic feet for the superheaters, which, in this case, were not large enough to utilize all the available so-called "waste heat."

One of the difficulties experienced in the use of retort coke in generators has been the rapid quenching of the fuel by the steam. Coke, being light, has less storage capacity for heat than has anthracite, and is more rapidly cooled. In my experience increasing the temperature of steam from 300° to 700° has enabled me to use soft coke with greater success. There is no difficulty in bringing steam to a temperature of over 600° before sending it into the generator, and with the "waste heat." After the first run, in blasting, the fixing chamber is heated before the generator is in condition to make gas, and a part of the "waste heat" can be stored in brickwork, to be absorbed by the steam during the succeeding run.

Gas issues from a fixing chamber at a high temperature, the heat it carries away being absorbed by water in the condensers. In a large plant now building it is sought to utilize this heat for the volatilization of oil before sending it into the apparatus. I believe this will be accomplished and good will result in two ways—heat otherwise wasted will be utilized, and the cooling effect of sending cold oil upon hot fuel will be avoided. The bad effect of this cold oil is greater than would appear at first thought. I have known of its cooling a path for itself through a shallow fuel bed, and actually reaching the ashpit as a liquid. I believe that if no "waste heat" is available for vaporizing the oil, it would pay to do it with steam. Cold oil chills the fuel and shortens the run, to prolong which is worthy the most earnest efforts of the gas maker. It is the period of production, and as it is long or short compared to the alternate period of blasting, so is the producing power of the plant greater or less.

I will speak of one more point in connection with fuel economy, and I know that my opinion upon it is different to that held by some water gas constructors. I refer to the proper direction in which to blast; whether it is the same as followed by the steam in making gas, or, as in my opinion, the reverse? The effect of making water gas is to cool the fuel. Only through the decomposition of steam, which absorbs a large quantity of heat, can water gas be produced, and the first layers of fuel operated upon are rapidly lowered in temperature until they reach that of the incoming steam. Where the blast is directly applied some of this fuel does not reignite thoroughly, for the cold air passes through it before reaching the still heated mass above. This is especially the case with coke, which, from its porosity, becomes more thoroughly cooled by the steam. Where the direction is reversed, and the steam enters at the top of the fuel, its cooling effect is entirely overcome at the next blasting, for the air, before reaching the cooled portion, passes through the heated mass below it. I have knowledge of an experiment which illustrates the good effect of this way of working. A plant in which the direction of steam and blast had been different was changed for a time to work on the other plan. The result was an increase of 7 pounds per 1,000 cubic feet of gas in the fuel account. There was no superheater connected with this plant. It should be mentioned that introducing steam at the top of a deep fuel bed has the effect of increasing the clinker, as does the superheating of the steam. This effect can, however, be overcome. I know of a plant which works in this way, and has not in six months had its fires drawn. At the end of every 12 hours wet steam is admitted at the bottom of the fire for one run. The effect is to soften the clinker, which is then easily broken and removed.

Upon the question of oil economy there are few points to be observed; but these few are of great importance to the water gas maker. If the temperature of the mixing chamber is such that the condensation contains only traces of lampblack or light oil, I think the manager need not worry about his oil account. I believe the best temperature to be a cherry red, but this depends upon the quality of the oil, and the area and height of the fixing chamber compared to the rate of make. I try

to run as near to the lampblack limit as possible without touching it. While, as coal gas makers, we have given time and labor to solve the problem how best to shorten the stay of gas in the retort, as water gas makers we seem hardly to have thought of the effect of long contact with hot bricks upon our enriching material. Reasoning from analogy, I believe that we should shorten the stay of our product in the fixing chamber to the least possible period consistent with the thorough gasification of the oil. The fact that we may find no deposit of carbon proves nothing; for, upon blasting, the deposit would be carried off unless very heavy.

To economize labor in water gas making it is necessary, as in all manufacturing, that everything the men have to handle should be convenient to them. The boiler can be on the firing floor; a double-cylinder engine on the floor below can always be started from above; and, by arranging these things thus conveniently, in a small works one smart man can make all the gas in hours of daylight. A works sending out 20,000 cu. ft. per day, with a storage capacity of 50,000, can be safely run by two men, who shall make gas but a part of one day in two, and can give the rest of their time to services, meter setting, etc.

I have so far treated of water gas as made by the cupola process only. To go into the question of the relative efficiency and economy of this and other systems of making carburetted water gas would make my contribution to this meeting too long. Before closing, however, I desire to compare the candle power developed per gallon of oil in pure oil gas; in a mixture of oil gas made in retorts with water gas made in cupolas; and in carburetted water gas made at one operation in cupolas.

Mr. J. Desha Patton has said that commercial benzene will yield, in regular working in a retort, 70 cu. ft. of 70-candle gas, or 4,900 candle-feet per gallon. In the Pintsch system the yield is, from crude oil, about 70-cu. ft. of 50-candle gas, or 3,500 candle-feet per gallon. The best result I have been able to obtain in clay retorts is 70 cu. ft. of 60-candle gas, or 4,200 candle-feet per gallon of naphtha. I have the results obtained from mixtures of oil and water gases in different proportions upon a commercial scale, the gases being made separately. At a small works in New England, where gas is made in this way of 35-candle power, the yield per gallon of naphtha, in 1883, was 3,509 candle-feet. At New Orleans, La., in June, 1885, the yield, making a 33½-candle gas, was 4,432 candle-feet per gallon; and though I have made many experiments with different mixtures, this is the best result I ever obtained.

The following results, representing, I think, fairly what can be done with the cupola system, are based upon information obtained by me directly from the books of companies, or the statements of engineers in charge. They vary considerably, and represent five different so-called "processes," the names of which, for obvious reasons, I do not give. The highest yield per gallon of which I have a record is 6,302 candle-feet. From that the figures range down thus: 5,647, 5,526, 5,471, 5,467, 5,251, 5,000, to 4,687 candle-feet per gallon. Here we have the material for a comparison of the results obtained from oil in regular working under three systems:

First, with pure oil gas 4,900, 4,200, 3,500 candle-feet.
Secondly, with gases mixed after
generation 4,432, 3,509 candle-feet.
Thirdly, with carburetted water
gas made at one operation in
cupolas 6,302 down to 4,687 candle-feet.

I believe the advantage in the cupola system to consist in the almost complete conversion of the oil into gas. In the retort process as I have worked it the tar made equals nearly 10 per cent. of the oil used. In the cupola system it is only about 2 per cent.

Discussion.

The President—As our membership numbers many water gas people, we ought to hear from them with regard to their experience in relation to some of the facts stated by Mr. Clark. Mr. Clark's paper contains a great deal of valuable information, which must be deliberately studied to be fully appreciated. For my part, I very much favor a deep bed of fuel, with the steam brought in on top.

Mr. Clark—Brought in in reverse from the blast?

The President—That is different from the experience of some companies whose working reports I have seen. Is not Mr. Lansden using a Granger generator, with a thin body of fuel?

Mr. Lansden—We were, but are not now.

The President—We would like to hear from you on that subject.

Mr. Lansden—A year ago we had two large Granger machines in the Washington (D. C.) works. Mr. McIlhenny had one of the machines lengthened out. In our original Granger machines the generators carried about 5½ to 6 feet of fuel, and the machines were fed by severa

small tanks, probably 5 feet in height by 2½ feet in diameter, the oil passing into each generator through four little cocks, fitted with glass gauges showing the oil while running. We took these out and dismantled the tanks, replacing them with a tank located some 300 or 400 feet from the works, elevated sufficiently to give us a supply for the whole machinery from one receptacle. I brought that into the works, attached a box with a float ball in it similar to an ordinary closet. I then attached, for each machine, an inch pipe, bringing it up through the floor to the height of about 3 feet, and put on that a 1-inch stopcock. The inch pipe then ran to the machine, and the machine was divided into four sections. The stopcock has a lever handle to it 12 inches long. Under that is the segment of a circle, by which the cock can be turned to the same point every time. That system enabled a machine that had been making 600,000 cu. ft. to produce 750,000 cu. ft. in the same time. We are running right along with it at that rate, and have even done better. I claim that the main thing secured is that we now have a regular feed of oil supplied all the time, insuring perfect uniformity.

Mr. Lowe—I would like to ask Mr. Lansden what, if any, advantage they found in increasing the fire below their generator.

Mr. Lansden—We found, just as Mr. Clark stated in his paper, that when using the blast from the bottom the fire would go out. Although the generators were of the same diameter, we were able to increase the capacity of the machine a little over 50 per cent.

Mr. Lowe—I am decidedly in favor of deep fires in generators. In fact, I think you cannot get them much too deep. I have used 12-foot fires, and found great advantage in them. It does not take any more coal to keep a deep than a shallow bed going; in fact, I think it takes considerably less. I think Mr. Clark's paper is a very able one. I have made many experiments, and my results closely coincide with what he has told us. I am a great advocate of using superheated steam, and believe we can make a third more gas from the same amount of coal with superheated steam than when wet steam is used. I never found much difference in the clinkering of a generator fire, using superheated steam over wet steam; and when clinkers did appear I adopted the remedy of introducing wet steam, which rapidly softens the clinkers and causes them to fall. If more than usually obstinate, I put in oyster shells, fluxing them down as you would in a blast furnace, and found it to be a very satisfactory plan.

The President—The Association would like to hear from Mr. A. C. Humphreys on this subject, as he has had much experience in it.

Mr. A. C. Humphreys—I do not find myself in a position to discuss Mr. Clark's paper, chiefly for the reason that I agree almost entirely with his every statement. There is no doubt that a deep fuel bed is the proper thing. Although in the past we have perhaps been identified with the shallow fuel bed, we have now rather eliminated that from our drawings. We are to-day putting in nothing less than 5-foot beds. With regard to superheated steam, there can be no question about the accuracy of Mr. Clark's position, because we want the heat in the steam for two purposes—as a matter of economy, and also for the better operation of the generator after it is admitted. From our experience, the question of where to admit the oil is not very important, provided we admit it in the right way when we get it there. The whole point is to bring it to the temperature required, and the temperature to which it should be superheated is entirely governed by the quality of the oil. We can handle naphtha without trouble by simply raising the temperature of the steam to the ordinary boiler pressure as we run the works. When using the heavy oil, which we do largely in many works, we have to bring about other methods for superheating it, and there comes in the question of using the waste products from the generator, or from the superheater, or perhaps the waste heat in the illuminating gas as it is made. I think Mr. Clark touched on that method in his paper. In regard to the exact proportion of superheater, and in relation to the regenerator, much yet remains for solution. In the past no doubt a great mistake was made in having the superheater entirely too small for the regenerator. Our practice now is this—say, for instance, that with the regenerator 5 feet in diameter, there is a fuel bed 5 feet in depth, the superheater being of the same diameter, and probably 22 feet high. A few years ago this would have been looked upon as absurd. We do not find, however, and have no reason yet to believe, that that superheater is too large, or that we subject the gas to contact with too great a heated surface, providing our temperatures are right. I am a very firm believer in having surface enough, and so being able to run at low temperatures. That is the only point in which I differ from Mr. Clark. I do not believe in keeping our temperature very high, if we can get our result without. Our experiments go to show that we can, provided we have surface enough. Especially is this the case in the use of heavy oils—I mean oils having a gravity of 27 to 33, which we are

using with entire success. We also class, under heavy oils, crude petroleum; and the treatment for those oils is entirely different from the treatment for naphtha. In a number of cases our superintendents have sent back word it was impossible to use the oil—that it could not be done. We have, in such cases, by following it up and insisting upon its use, and sending directions, and perhaps a special engineer to look after the thing, been so far successful, finally, in every case. One or two cases exist in which we are still having trouble, but no doubt it will be remedied. The whole question is one as to temperature and heated surface.

Mr. Lansden—I will say, with reference to the size of the superheater spoken of, that we have one 24 feet high; and I know that it works better than those which are only 18. I would like to ask Mr. Clark what he considers the fair amount of coal to the thousand feet of gas, for all purposes.

Mr. Clark—That is rather a pointed question. The answer depends, of course, on the size of the works. I do not know of anything better than 40 pounds per thousand, all round. If there is anything better than that I am not aware of it.

The President—The Association would like to hear from Mr. Edgerton, of New Orleans, on this question.

Mr. Edgerton—I have nothing to say with regard to this, except to ask Mr. Clark how his comparison of the yield and quality of gas is based. I do not understand the comparison. I have ordinarily seen it stated that so many gallons of oil will make a thousand feet of a certain standard. I must confess to a little confusion, and I do not understand exactly what results he gets at. I would like to inquire the number of gallons of oil and the pounds of fuel used per thousand cubic feet of gas.

Mr. Clark—My comparison was simply regarding the illuminating power of oil as used in the two different methods. First, the mixture of oil and water gas and then carburetted, and water gas made at one operation, I put into candle feet, as being the simplest way of showing the amount of light that we got from a gallon of oil. In the case of pure oil I multiplied the yield per gallon by the candle power of the oil. In the case of the mixture of oil and water gas I multiplied the candle power by one thousand feet, and divided by the number of gallons used in making the thousand feet, which gave the number of light units as expressed in candle feet which we got from one gallon of oil. I am aware this is not the most scientific way of doing it, yet it is the best way I can think of presenting it to coal gas men who are familiar with Mr. Farmer's candle feet theory.

Mr. Edgerton—What style of burner did you use in testing the water gas?

Mr. Clark—In testing the water gas I employed the simple burner in everyday use, and a Scotch tip burner, consuming from 1 to 2 feet per hour on the pure oil gas.

Mr. Edgerton—I must confess, if I understand it correctly in candle feet, you show that in one process, or by my regenerator and superheater system, there is some 30 per cent. difference than when manufactured separately. Is that correct?

Mr. Clark—I think so. I did not work out the percentage any higher.

Mr. Edgerton—That statement contains something entirely novel. I cannot discuss it in candle feet, because my results are not translated into candle feet. But in the plan of manufacturing water gas at one operation, and then carburetted, and manufacturing again, and passing through the superheater, there is no published result which shows any such discrepancy. I should be very glad to know where such statements can be found, so that I may look into them. I do not doubt the result stated; but still I would like to examine further.

Mr. Clark—The results, with reference to gases made separately and mixed afterwards, were, as stated, obtained in one case from the New Orleans works, the other being the result of a year's work accomplished in a New England gas plant. Regarding the results obtained in making the gas at one process, these were obtained, as stated, with five different processes. I do not give their names, because I do not want to introduce civil war into this Association; but I either have the figures myself from books of the companies, or obtained them from statements of the engineers in charge.

Mr. Edgerton—Do they not largely exceed any public statement?

Mr. Clark—I do not think so. I took them as being a fair average. Some of those figures were obtained from members of this Association.

Mr. Pearson—You have given the number of candle feet to the gallon of oil. Can you give the figures as to the pounds of coal and the amount of water as steam; and can you tell us what percentage of carbonic oxide is present in the highly superheated steam as compared with the wet steam?

Mr. Clark—The proportion of carbonic oxide would be greater, because the gas would be washed with less carbonic acid.

Mr. Pearson—Can you give the relative proportion?

Mr. Clark—In the finished gas I suppose there is 30 per cent.

Mr. E. C. Jones—I was pleased to hear Mr. Clark state his reduction of gas in candle feet. There is a wide diversity of opinion with regard to the amount of oil used per thousand feet, to produce a given candle power of gas. I am very much in favor of hourly or half-hourly observation of the photometer in connection with the amount of gas made. If it can be demonstrated that there is 4,200 candle feet in a gallon of oil of certain quality, I think that the measure of the production of gas in candle feet will tell us what we are doing with our oil—whether we are making gas with it, or making lampblack of it.

On motion of Mr. Boardman, a vote of thanks was tendered Mr. Clark for his paper.

FIRST DAY—AFTERNOON SESSION.

Mr. A. C. Humphreys, M.E., Phila., Pa., read the following paper, entitled—

“ILLUMINATION VS. CANDLE POWER.”

I have undertaken to prepare for this meeting a paper under the title of “Illumination vs. Candle Power.” The subject of measurement of light is a large one, and I cannot hope to more than touch upon certain special features of the subject. The title will suggest that I have in mind some of the papers recently written in this line, namely: The paper by Mr. Boardman,* at our last year's meeting; the papers by Messrs. Prichard† and Taber,‡ at the last meeting of the New England Association; and the paper by Mr. Chollar,§ at the last meeting of the Western Association.

Mr. Boardman told us, you will remember, of the increase from 16 to 22-candle power he obtained by substituting a student's Argand chimney for a regular Argand chimney, but that while he obtained this apparent advantage the “illumination” was actually less, as shown by applying the chimney to an Argand at his house. In the paper and the following discussion you were told that a white light would not “diffuse” as well as a yellow light. It was also stated during the discussion, and with great confidence, that a 16 candle coal gas gave as much light, on account of this “extra diffusibility,” as a 20-candle water gas—the 20-candle water gas being whiter than the coal gas; and in explanation of this it was suggested that the whiter light from water gas “was intense, local, but not diffusive like coal gas.”

In Mr. Prichard's paper considerable stress is laid upon a law of the intensity of light to the effect that “rays emitted obliquely from a surface are less intense in proportion as they are more inclined to the surface which emits them,” and then, that by this law “the rays of light from a flame as they leave the horizontal and approach the vertical, leave the maximum measured candle power and approach the minimum of zero.” We were also told that flames must be of the same size and same color to enable us to measure their lighting power correctly. The old question of the opal globe was also brought up prominently. It was also proposed that *daylight should be* regarded as the standard—that is, a white light. Also, that a 16-candle gas, which was whiter than the richer 20-candle, on account of its increased “temperature per unit of flame areas,” produced a better light than the richer gas—of Boston. A disagreement from what has gone before is here to be noted.

By Mr. Taber's paper we were reminded of the uncertainty of our photometrical measurements. The varying quality of the so-called standard candle, the necessity for bars of varying length according to the strength of the light, the lack of accurate formula for correction of candle and gas consumption, the question as to how to read the disc, the color trouble, the abnormal condition of atmosphere—fog, for instance—entering as a disturbing element. And also, the opinion is expressed that the subject is one for the physicist instead of the gas engineer. Then, by a carefully prepared table, it is to be noticed that the candle power does not follow the amount of bromine illuminants, and that CO is a positive evil. In the discussion which followed the example of the illumination from a bull's-eye lantern is used to demonstrate the varying power of the rays emitted by a gas flame according to the angle they make with the surface of the flame. Also, we were told that candle power “means nothing.” Mr. Taber found that Mr. Boardman's experiment gave him an increase in candle power of from 16 to 19.44. Mr. Prichard had found no difference whatever.

Mr. Thomas spoke of the relative values of oil lights and gas lights—compared directly, I presume—and that the “illuminating duty” of one 18-candle gas flame was found to be far in excess of two 12-candle oil lamps. This was the result of a careful test—presumably with a bar photometer. The experience of Dr. Morton in measuring so-called 2,000-candle electric lights is referred to, and we are reminded that he only found them to be from 500 to 1,100 candles; and the opinion is expressed that if a photometer had been used in these experiments the light

would have largely exceeded 1,100 candles. Also, that an observer looking at a 36-candle and a 19-candle gas, as ordinarily burned, would have difficulty in distinguishing between them; and, still further, the belief was expressed that a 19-candle gas would afford a better illumination than a 36-candle gas. Parenthetically, I would here like to say that if the gentlemen would guarantee to convince our consumers on this point, I should be only too glad to accept the theory, anyway during business hours, and let the statement go unchallenged.

At the close of this discussion Messrs. Prichard and Taber were appointed as a committee to continue their investigations and experiments during the following year.

In Mr. Chollar's paper we are told to beware how we put our faith in the law which says that the light from a luminous body decreases in proportion to the square of the distance—that is, the law upon which photometry is based; and he also refers to Prof. Tait's statement of the law, namely, “If the medium be transparent, the intensity of illumination which a luminous *point* can produce on a *white surface directly* exposed to it is inversely as the square of the distance.”

Attention is then drawn to the fact that the well-known law is simply following out the principle that the surfaces of spheres are to each other as the squares of their diameters. Then the proof is attempted of the proposition that, “irrespective of intensity, the quantity of light from a luminous body at any particular point is independent of the distance of the body, and is in direct proportion to its diameter;” and it is stated, “The rule governing the value of lights, therefore, would be something like this: The light from a luminous body is inversely as the square of its distance, and directly as its projected area.” We are also advised in the study of the subject to drop empiricism and go at the matter as thoroughly and systematically as the electricians do in their measurements; and we are encouraged to believe that we shall be able, by means of high candle power lamps, to compete with the 1,200 and 2,000 candle power electric lights.

These papers you have doubtless all read, and it may seem that it was unnecessary for me at this time to refer to them at such length. My object has been to bring clearly before you the fact that there is in the minds of the gas engineers of America much uncertainty on the subject of light and its measurement, and to demonstrate the necessity of a special consideration of this subject on the part of this Association. I take it for granted that we are all gas engineers—not coal gas engineers, or water gas engineers, or oil gas engineers, or wood gas engineers, or any other special kind of gas engineers. Perhaps it would be better if we said we were light engineers. If we cannot go this far, it is high time we went far enough to be able to say that in this Association we are gas engineers, and that we are ready to study any subject in connection with our business so as, as far as possible, to get at the exact truth, let it strike where it will. I believe most of the members will acknowledge there is room for improvement in this direction, though I am, for one, glad to acknowledge there is every appearance of a movement toward the overthrow of prejudice. I cannot expect to try to meet all the points raised in the papers referred to, and I know you would be sorry to have me attempt it. I believe, however, that I have been able to make certain experiments which will tend to clear up some of the questions raised.

It certainly is very deplorable if we must acknowledge to the public that we can tell actually nothing as to the value of the light we offer to them; and that is what we must practically acknowledge if we leave the subject at this point. Of course, the foundation laws of intensity of light which have governed us in our photometric work are:

I. The intensity of illumination on a given surface is inversely as the square of the distance from the source of light.

II. The intensity of illumination which is received obliquely is proportional to the cosine of the angle which the luminous rays make with the normal to the illuminated surface.

It is with the first law we are chiefly concerned, for we can provide against the second law interfering in our photometric work by having the disc at right angles to the rays from the light to be measured; and this can be practically done, even if two candles are used, by the use of a bar of sufficient length.

I think that Mr. Prichard, where in his paper he refers to the rays emitted obliquely, has this law in mind, and most of his troubles appear to come from a misconception of this law. The law has nothing to do with the emission of light from an oblique luminous surface, but refers to the illumination of a surface oblique to the rays, and simply shows that mathematically, by reason of the incline of the surface, a greater area is exposed to the rays. Therefore we spread a certain number of rays over a greater area than in the case of a perpendicular surface, and consequently the intensity of illumination is diminished. And the exact measure of this inclined surface, as compared with the perpendicular

*Vol. XLVI., Jan. 3, '87, p. 7. †Same vol., Mar. 2, pp. 130, 140. §Vol. XLVII., July 2, '87, p. 7.

TABLE -

CANDLE POWER	MEAN		CANDLE POWER
	DIFF. % OF LOSS	ANGLE	
24.45	19.15	5.30	21.80
22.75	18.15	4.60	20.45
21.25	17.80	3.45	19.57
20.45	16.10	4.35	18.28
14.65	11.50	3.15	13.07
13.25	12.95	1.20	12.60
10.85	9.34	1.51	10.09
10.09	9.20	0.89	9.64
8.07	7.00	1.07	7.53
8.27	8.31	0.76	8.89
8.33	7.57	0.76	7.05
8.00	5.73	0.27	5.87
4.50	4.35	0.15	4.43
2.17	2.17	0.00	2.17
1.05	1.05	0.00	1.05

DIAGRAM OF THE VARIATION OF THE CANDLE-POWER OF A BAT-WING FLAME, BY OBSERVATIONS FROM THE FLAT TO THE EDGE OF THE FLAME.

MEAN ANGLE OF MEAN LIGHT -

— 4.68 —

MEAN OF 15 OBSERVATIONS

CANDLES •

PHOTOMETER BAR.

90° or FLAT

BAT-WING FLAME - 0° or EDGE

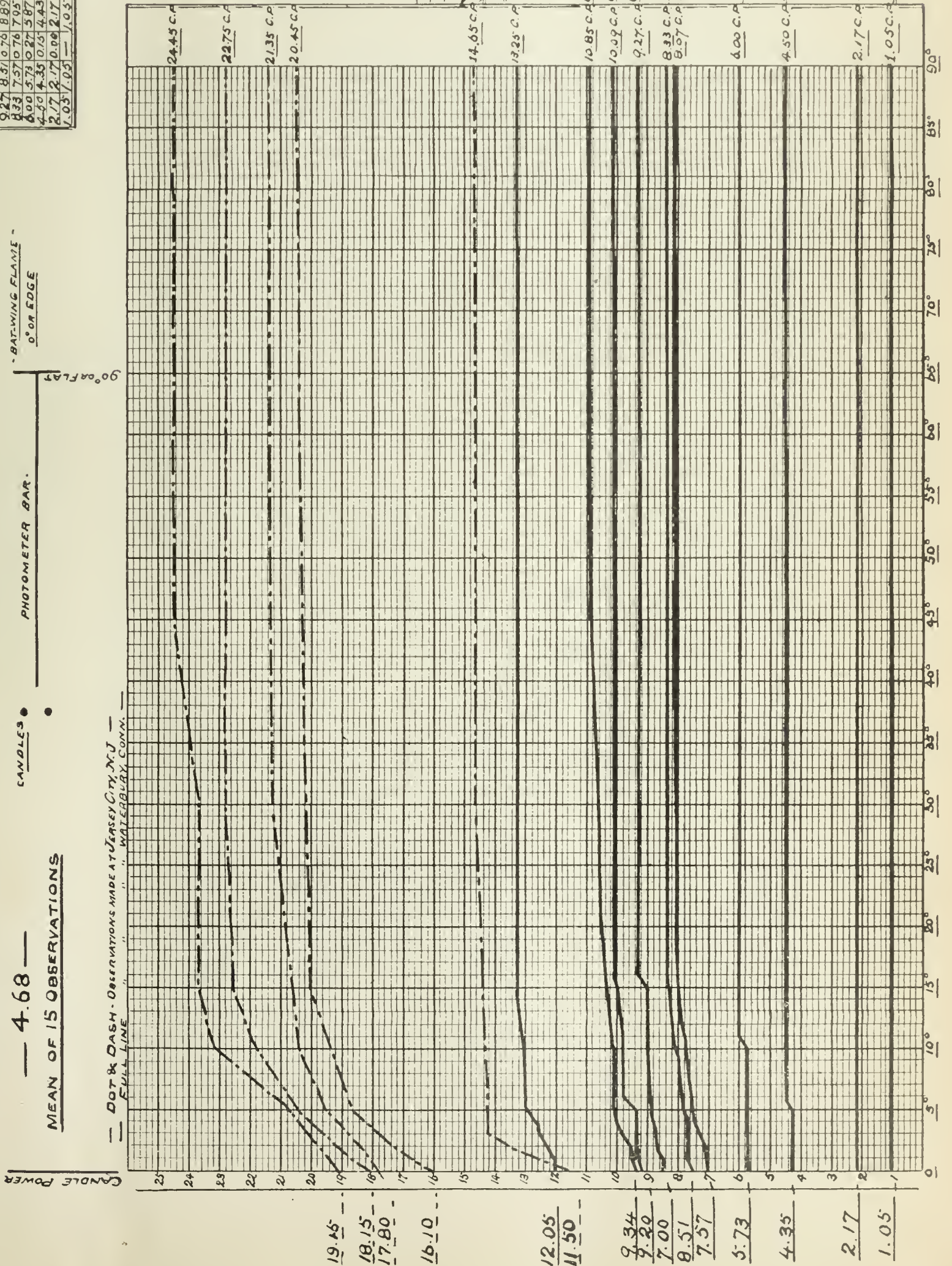

NOTE: MIXTURES OF JERSEY CITY GAS NOT CALCULATED - GAS MIXED IN PIPES - SAME BURNER IN EVERY CASE.

MIXTURES OF WATER GAS	ILLUMINATING POWER	
	Cu.Ft.	C.P.
9.1	4.9	20.38
0.25	4.75	21.82
0.50	4.50	20.82
0.75	4.25	21.7
1.0	4.0	22.3
1.25	3.75	19.56
1.50	3.50	—
2.0	3.0	23.0
2.5	2.5	20.25

DEGREES

surface, if found to be proportional to the cosine of the angle made by the ray with the normal to the illumined surface. This, therefore, need not come in to bother us. We only have to take account of it so far as to see to it that our photometer is adjusted to reduce the error from this source practically to zero. Part of the confusion on this point may have come from the fact that a flame is not entirely transparent to its own light, as shown by the difference in readings shown between the flame on edge and the flame on the flat. On this point there has been great diversity of opinion, and the rule, I believe, somewhat generally followed has been to take the reading from the flame at 45° as giving the average.

In my past experiments I very quickly satisfied myself of the incorrectness of this as a general rule, and, therefore, in connection with this work I assigned to one of my assistants a somewhat elaborate set of experiments to determine what angle gave the mean reading, and this with different qualities of gas. The following table, prepared by the assistant referred to (Mr. C. Russell Collins, M.E.), shows the *average* of the *mean* readings, or the mean angle of mean light to be 4.68° , and that this mean angle varies with the candle power of the gas. The differences of candle power were obtained by mixing different percentages of fuel (non-illuminating) water gas and illuminating water gas.

[For tables and accompanying diagram, see Supplement.]

By this table we find the angle of mean illumination, or mean candle power for the whole series of experiments, is 4.68° . In the case of the mixture which gave 24.45-candle power on the flat, the mean angle was 7.25° . The largest mean angle was in the case of the 6-candle power on the flat, in which case it was 10.25° . In two cases of very low candle power no difference from edge to flat was observable. This question of the mean angle is an important one, and the table given goes to show that, taking the average, our flat flame burner is doing its best for about 280° out of the 360° . It is also worthy of note that at 45° we have practically reached the maximum in every case. The percentage of difference in candle power between the edge and flat runs from zero to 21.67. This difference increases apparently with the candle power of the gas. Intensity of combustion no doubt enters in also to affect the transparency of the flame. The different mixtures were burned with the same burner. Had a burner been carefully selected for each mixture, a different candle power would have been obtained, and no doubt a different result as to variation of candle power from edge to flat.

The importance of adjusting a burner for a particular gas, especially in comparative tests, is, I believe, often lost sight of. For instance, we have the table showing loss of light by mixing air with 12-candle power gas, 1 per cent. of air destroying 6 per cent. of light, and so on up to 40 per cent., where the light is entirely destroyed.

Some years ago I had occasion to test this matter with Pintsch gas. A full set of experiments was made, and of course I at once saw that while there was a very serious loss if the same burner was used, there was no such loss with this rich gas as in the case of the 12-candle power gas. By very carefully selecting a burner for each mixture I finally succeeded in mixing in 40 per cent. of air in a 50-candle gas, and was still able to get as high a result per foot of gas used, as I obtained by the unmixed gas burned in the small burner selected therefor.

I bring this point out also to emphasize the fact that in making our experiments and drawing our conclusions therefrom, we must bear in mind that to compare two gases we must have a burner properly adjusted for each. For instance, Mr. Boardman with his student argand chimney varied his candle power from 16 to 22; Mr. Taber raised his from 16 to 19.4; Mr. Prichard was unable to observe any difference. In my first experiments with gas varying from 24.78 to 12.70, and under different consumptions, I obtained varying results, sometimes there being a gain for student argand chimney, and sometimes a loss. In my last series of experiments, the candle power of the coal gas fell from 16.47 to 14.37. I do not doubt I could have obtained different results in both cases by different adjustments as to height of flame alone.

This suggests, did Mr. Boardman get the same adjustment at his house that he got in his photometer room; and did he allow in his practical test at his house (where he was vainly trying to read, and his wife to thread her needle) for the fact that, when his argand with the ordinary chimney had been consuming probably 7 feet, with the student argand chimney he was only consuming about 3.8

Say 7 feet 16-candle power gas=22.4-candle power.

Say 3.8 feet 22-candle power gas=16.72-candle power.

The fact of smaller consumption being necessary to avoid smoke in the case of student argand chimney, and also the fact that these experiments were made 10 years previous to the reading of his paper, Mr. Boardman informed me of by letter.

Coming back to the first law—this is a law entirely dependent upon mathematical principles, and I was surprised to find an intimation in Mr. Chollar's paper that the law was supposed by some to be based upon something outside of mathematics. The law is easily illustrated by supposing a light coming from a point situated at the geometrical center of a hollow sphere—the total illumination from this point will be spread over the inside of this sphere and every part of the surface will be equally illuminated. Suppose now that the sphere is increased in size until its radius is just twice the radius in the first case; as the areas of surfaces of spheres vary as the squares of their diameters or radii, the sphere in the second case will have an area just four times as great as in the first case, and as the amount of light has not been changed, the same amount will have to be spread over four times as great an area—that is, the intensity of illumination is one-fourth as great, or inversely as the square of the distance from the source of illumination.

The law as stated by Prof. Tait, and which Mr. Chollar thinks so much preferable, is the law as it is generally understood; but it is stated more fully than is usual, and includes a reference to the second law. We all know that the calculations are based upon the supposition of the light coming from a point. We also understand that the medium through which the light is to be transmitted must be transparent; we do not expect a law that will apply alike to all conditions in this direction—for instance, the interposition of a red or blue globe, a globe full of steam to represent fog, etc. We also expect results to vary as to illumination of objects different in color. We do not expect to get the same effect if our walls are black as if they were white; and, as before stated, we do not expect to measure lights against each other, unless we provide for the rays in both cases being practically normal to the disk or illuminated object. Mr. Chollar then attempts to prove a new law, in place of our old friend which has stood by us so many years, to the effect that irrespective of intensity the quantity of light is independent of the distance. The second diagram of the article is intended to prove this; but if any of you will study this diagram and bear in mind that every point of the line emits rays in every direction, you will find that the diagram affords no such proof. As in all other laboratory work, we must in the application of the laws involved take account of the sources of error that naturally come in, and see to it that the instrument is used as designed to reduce the error from these sources to a minimum. For instance, length of bar—if the light at one end of the bar is very intense we must expect to lengthen our bar, for obvious reasons. A man's eye should suggest the necessity at once, for if he uses a short bar for a light of even 200-candle power he must expect to so partially paralyze his eye as to render his results valueless. This lengthening of the bar also takes care of the trouble from varying angle of incidence. Difference of color does not interfere much except in the case of a very bright light at one end; then, by lengthening your bar this is so reduced that by considering only the edges of the disk—that is, trying to keep in mind the definition of the disk—a man in moderate practice should arrive at a practically accurate result. The use of a standard burner, such as the Methven or Edgerton, is of great assistance, reducing the trouble from both foregoing sources of error and also overcoming the candle trouble.

As to varying quality of candle—get good candles, and if you find, after careful handling, they are running much out of the way, reject them. As to corrections of gas, set your meter to consume five feet, or almost exactly five feet, if it is a gas proper for such an adjustment. Any correction then necessary to introduce can be safely made by the usual rule. If the gas is, say, a forty-five-candle oil gas, use the burner that will burn it properly, and then figure it to the five-foot basis if you wish to do so for comparison. As that is the proper adjustment for that gas, that is the way to consider its value as a light-giver—namely, direct proportion.

Let us now consider for a moment some of the points which have puzzled us all, and which I believe have led to this discussion. We say an arc light is not so diffusive as a large gas flame, and that we do not get the same duty from it, comparatively. Why should we expect to? Here is an arc light sending out the light of 500 to 1,200 candles, and all practically from a point—the light-giving sur-

face is not bigger than that of one candle. Does it not necessarily follow that we have a very defective distribution? and does not the very law of inverse squares demand that the distribution be uneven—intense around the light source and falling off so rapidly following the square of the distance?

Bear in mind what this falling off of candle power means—a 2,000-candle power arc light is, at a distance of twenty feet, only giving the illumination of five candles at a distance of one foot. Take the 2,000-candle power and distribute it around in 400 gas flames and we necessarily get a more even illumination and a better working result. Then, again, the eye must seek the light and it is partially paralyzed by its brilliancy and the contrasts. If we go from a dark room to where there is sunlight on snow, are we not blinded for the time being? The same principle applies to the case of the eye and the arc light. It is a physiological effect and has absolutely nothing to do with the laws regarding the intensity of illumination. Again, the arc light comes from a point, and hence intense shadows are made; whereas, in the case of a light-giving surface, the shadows are toned down by the rays from the wide-apart portions of the surface getting behind portions of the object which are in the shadow of other rays. We are familiar with this under the name of penumbra. For instance, if we had a light-giving surface which extended all around the object we should have no shadow at all.

Take the case of the opal globe. A certain percentage of the light is cut out as claimed, but the distribution of the light which remains is much better by reason of the enlarged light-giving surface, and as the flame is entirely hidden from view the eye is not subjected to any marked contrast, and is so better able to do its duty. That is all there is in that, for the cases referred to of more brilliant cones of light are simply cases of reflection, as in the instance of the bull's-eye lantern referred to. Of course, we cannot concentrate our light upon any one set of lines and still have its full value elsewhere. Another point which enters in to confuse is obstruction of light, as in the case of the arc light. We must expect the arc light to give more light in the horizontal, for the light above and below is obstructed by the carbon pencil. We must bear in mind what is the *unavailable* light-giving surface in each case and for each position reached by the rays. We have this obstruction in the case of gas flames, as shown, due perhaps to the opacity of the carbon particles, or, perhaps, if they are transparent, to their power of refraction; and if we find in higher candle power lights this difference increases we should not be surprised, for it is reasonable to suppose as the carbon particles increase in number or the flame becomes more dense, this interference will be increased, whatever its exact character. You will remember, the lighthouse authorities find they can use to great advantage animal and vegetable oils for argands made up of concentric rings of flame. They can also economically do so in case of gas; but with the dense flame of the mineral oil lamp they soon reach a point where it is no longer economy to increase the number of flames, because so much of the light from the inner flames is obstructed by the outer flames.

Mr. Thomas, you will remember, speaks of the results obtained by Dr. Morton in measuring arc lights, and he draws the conclusion, from the fact that the results obtained were so much less than those claimed by the electric light men, that the photometer in the first place must have been at fault. Do we not go out of our way to mislead ourselves by such arguments? Because the electric light men have overstated the value of their light (bear in mind their so-called French method), is that any reason we should discredit the photometer? Mr. Thomas also says: "If the intensity of this light had been measured on a photometer it would have largely exceeded the maximum figure given." I presume Dr. Morton's experiments at Bridgeport are the ones referred to. In these experiments Dr. Morton used a photometer box on wheels, with two candles at one end and the electric light thirty feet away. That is, the length of the box was re-enforced by a steel tape-line thirty feet long. These results were obtained by a photometer, and I venture to assert Dr. Morton would have been puzzled to proceed other than by means of a photometer. Of course, as we should expect, Dr. Morton selected a photometer of proper length, etc., for the special work in hand. In passing, and to show how carefully all of our steps in experimental work have to be guarded, it is to be noted it was here shown that there is a certain amount of error introduced by reason of the unequal reflection of the light along the inside of the box, in case of lights far away compared with those near; the angle of incidence as to the sides of the box in the case of the near light being smaller and so leading to a greater number of reflections. But of course if the

box is blackened very "flat," this source of error is slight. Again, as to the illuminating duty of two oil lamps of 12 candles, each being less than that of one gas flame of 18 candles, how did this experimenter arrive at these results? Was the despised photometer the instrument by which these results were obtained? In regard to the effect of CO in gas as a diluent, which has been referred to, do we not make the mistake of comparing it with CH₄, calling CH₄ a neutral, and so by comparison proving that CO is an actual negative? I know that CH₄ has been generally classed as a neutral, but Dr. Morton, in some experiments made some time ago, proved that in chemically pure CH₄ he had a gas of certain illuminating value. He even deposited soot from the flame upon a cold metal surface; hence while CH₄ may, as stated, be a more valuable diluent than CO, we probably get a more correct understanding of the question of illuminants and diluents by recognizing this double value of the CH₄.

The following experiments were designed to cover the questions in regard to diffusiveness, lack of diffusiveness, local intensity, etc., etc.

I felt that while such experiments ought not to be necessary, if made they would be conclusive.

The idea was to have a long photometer room and so arranged that two lights could be supplied with water gas and coal gas, respectively, through separate meters, the connections to be so made that the lights could be shifted out step by step from the center of the bar, so that the bar could be varied in length, say from 6 feet to 20 or 30 feet. If, then, the lights were adjusted in the first place at 3 feet each from the center, and the quantity of gas adjusted so that the illumination on the disk should be equal, the question of local intensity could be settled by taking readings at four feet each from the center, five feet, six feet, etc., and if the equal illumination was still obtained with the original consumption of the gases then we could claim that local intensity was effectually disproved.

This experiment I assigned to two of my assistants especially selected for this work, A. G. Glasgow, M.E., and J. M. Rusby, M.E. The proper arrangements were made, and experiments made which went to show that the lengthening of the photometer bar did not change the results. Having checked up the results and provided for still greater exactness in the readings, I made a series of experiments myself, Messrs. Glasgow and Rusby assisting, as follows:

EXPERIMENT No. I.

Water Gas. Bat-Wing Burner.			Coal Gas. "D" Sugg Argand.		
Dist. from center.	Sight Box.	Consumption, feet per hour.	Consumption, feet per hour.	Sight Box.	Dist. from center.
3 feet	=	3.7	4.9	=	3 feet
5 "	=	3.7	4.9	=	5 "
7 "	=	3.7	4.9	=	7 "
9 "	=	3.7	4.9	=	9 "
10 "	± 1-8	3.7	4.9	± 1-8	10 "
11 "	± 3-8	3.7	4.9	± 3-8	11 "
12 "	± 1 1-4	3.675	4.875	± 1 1-4	12 "

EXPERIMENT No. II.

Water Gas. Bat-Wing Burner.			Coal Gas. "D" Sugg Argand with Student's Argand Chimney, Flame 4 in.		
Dist. from center.	Sight Box.	Consumption.	Consumption.	Sight Box.	Dist. from center.
3 feet	=	3.075	4.4	=	3 feet
5 "	=	3.075	4.4	=	5 "
7 "	=	3.075	4.4	=	7 "
9 "	± 3-4	3.100	4.4	± 3-4	9 "
			N.B.		

N.B.—Five feet consumption (with student argand chimney) gave smoke.

EXPERIMENT No. III.

Water Gas. Welsbach Burner.			Coal Gas. "D" Sngg Argand.		
Dist. from center.	Sight Box.	Consump- tion.	Consump- tion.	Sight Box.	Dist. from center.
3 feet	=	2.01	4.65	=	3 feet
5 "	=	2.04	4.65	=	5 "
7 "	=	1.97	4.65	=	7 "
9 "	±1-4 in.	2.05	4.65	±1-4 in.	9 "
11 "	+1-4 "	1.99	4.65	-1-4 "	11 "

Each of these three experiments conclusively proves that the white light is diffused exactly as well as the yellow, there not being a particle of difference in favor of either. These are facts behind which we cannot go.

The coal gas used was of 16.47-candle power. With the student argand chimney the candle power was 14.37. Candle power of the water gas, 23.

It will be noticed that I used a Welsbach burner also. This was done to make a still more severe test of the question, for the Welsbach burner used was as much whiter than the water gas, as the water gas was whiter than the coal gas. It will also be noticed that there was more variation in the consumption of gas in the case of the Welsbach. This was because a small variation in consumption in this burner makes no appreciable difference in amount of light, and as I determined this fact before, I did not take so much time to adjust the consumption as I did in the other cases.

In conclusion, I beg to offer the opinion that a *white* light will be the best light for actual illumination, apart from considerations as to warmth of color, etc. The definitions both of color and line will be more accurate. Unfortunately, the white light is also generally the more intense light, and, therefore, more concentrated—comes from a smaller surface—and if so, is, therefore, open to the objections referred to. Let us understand the matter, though, and not confuse the subject by ascribing the trouble to the *whiteness* of the light. If we had a white light and a yellow light from an equal area in each case, the white light would be the best illuminator. We have some rooms so equipped that we can light by means of the flat flame burner (New York City gas), by means of the Welsbach burner consuming the same gas, or by means of the incandescent electric light. Comparing the two latter we find the Welsbach to be much the whiter, but still not so distressing to the eye as the electric. The reason is obvious. The light from the latter is from a surface of hardly appreciable size, whereas the Welsbach light comes from a surface about equal to that from an ordinary argand burner.

I agree with one of the gentlemen quoted that in the study of this subject empiricism should be dropped and the subject studied scientifically and thoroughly. I do not think that we shall be following the proposed line of investigation, however, by going out of our way to attack well-established laws. Do not let us attempt this until we are sure of our ground. One of the counts made against the established laws of light was that they were 150 years old. The law of gravitation as determined by Newton is still older, but we are not yet in a position to pronounce it false on that account.

That there is room for much further study in this direction on our part I do not doubt, and it might be well for this Association to provide, perhaps, by the appointment of a committee, as in the case of the New England Association, for gathering together the results obtained by different experimenters during the coming year, the results to be properly prepared and presented to the Association at its next meeting.

The President—As we have another paper on this subject, I think it would be better to read it now and discuss them jointly afterwards.

In accordance with this suggestion, Mr. Edward C. Jones, of South Boston, Mass., read his paper on

THE RELATION OF INTENSITY OF LIGHT AND VISUAL PERCEPTION.

Mr. President and Gentlemen of the Association:—In presenting for your consideration a few humble thoughts, I trust that my unfinished work may be taken up and treated in a more comprehensive manner by some of the master minds of our Association.

In the various discussions of the questions of candle power and illumination, as well as the cause of the increase in consumption of gas from year to year, one of the most important factors has been almost ignored—the human eye—that wonderful organ through which we receive all impressions of either candle power or illumination.

It may be said that the physiology of vision is not pertinent to the gas business, which we are here to discuss, yet it bears the same relationship to it as a judge on the bench to a criminal on trial. To it we must plead our cause, and on its judgment depends the success of our industry.

A large proportion of the companies manufacturing gas at the present time style themselves gas light companies—that is, they morally carry the gas beyond the meter to the burner of the consumer, where it is decomposed by heat, and produces that subtle, vibrating substance, light—described by some as “undulations of the ether,” and by others as simply “effect.”

The eye may be compared to the photographic camera. It consists of a series of lenses and media, arranged in a dark chamber, the iris acting as a diaphragm, to govern the quantity of light admitted, and the object of the apparatus is to form a distinct image of external objects on the retina, which is the sensitive plate; and it is with the retina we must become best acquainted, for we furnish the stimulant to which this retinal plate is sensitive.

The retina is the termination of the optic nerve in the eye, and is shaped something like an umbrella turned inside out, the handle representing the optic nerve. The retina is the true terminal organ on which light exerts a specific action, and the impression conveyed to our minds of intensity of light depends wholly on the condition, or, we may say, excitability of the retina.

The sunlight—proceeding as it does from one source, and thoroughly diffused and toned for our use, and dealt out to us in healthful allowance—is, of course, the natural light. Its action on the retina is stimulating to the proper degree, and the rest we obtain during the hours of darkness is tonic in effect on the retina. But we must work overtime, and supply a substitute for sunlight. We take a candle, light it, place the source of light in close proximity to our eyes, and to work. The light seems sufficient, but soon the retina becomes hardened to the light of one candle, and we must provide *two*. We gradually increase the number of hours of work of the retina by artificial light, and provide for its stimulation fluid lamps, 12-candle gas, kerosene, 20-candle gas, electric arc lights, and an innumerable quantity of incandescent electric lamps, until finally we use regenerative gas burners, and place two or three 16-candle incandescent electric lamps inside of our roll-top desks.

As the intensity of light is increased, it seems that the excitability of the retina is diminished, for all sensory nerves bear a strong relationship to each other. Now, we all know how a *little* mustard will burn the tongue, but as we persist in using it, we may increase the amount gradually until a spoonful will have no more effect on the nerves of taste than so much yellow ochre. The same is true of the sense of smell. For instance, as we enter a room strongly perfumed with a delightful odor, it reaches our sense of smell, but after remaining a few minutes under its influence we are wholly oblivious to the presence of any odor.

In the introduction of large regenerative burners to store windows, we explain to the consumer the increase of candle power developed from the gas and the number of times brighter it will be than the adjoining window provided with two four-foot lava-tip burners. The consumer looks with expectant eyes for a wonderful illumination, but a shade of disappointment crosses his face as he says: “There may be four times as much candle power, but the window does not seem twice as light as the other one.”

The difference between the theoretical increase of intensity of light and the practical impression produced on the retina induced me to search for authority on the subject, and, among others, appears, in the *Encyclopedia Britannica*, under the subject “Eye,” the following:

“Fechner’s law regulates the relation between the stimulus and the sensational effect in sensory impressions. This law is that the sensational effect does not increase proportionally to the stimulus, but as the logarithm of the stimulus. Thus, supposing the stimulus to be 10, 100, or 1,000 times increased, the sensational effect will not be 10, 100, or 1,000 times, but only 1, 2, and 3 times greater.” You understand that where I have made use of the word “stimulus” it means “light,” and sensational effect “the impression of the light on the retina.”

The law of Fechner explains the disappointment of the shop-keeper, and aside from the diminished excitability, or hardening of the retina, produced by long exposure to intense light and repeated fatigue, presents the following facts for our consideration.

A 16-candle gas produces an impression equal to the log. 1.204120, while a 20-candle gas produces an impression equal to the log. 1.301030. Thus the candle power is increased 25 per cent., but the impression of brightness on the retina is increased only 8.4 per cent.

The doubling of candle power from 20 to 40 candles causes simply an increase of 23 per cent. of stimulation of the retina, while a 100-candle light will produce only twice the effect on the retina of that exerted by a 10-candle light, notwithstanding the intensity of light is increased ten-fold. This ratio holds good until the retina is exposed to light so intense that we cannot distinguish any increase in brightness.

The gas engineer and the interior decorator should combine their efforts to please the public eye—the one, to supply a mellow and thoroughly diffused light, with no dark shadows lurking about to strain the eyes; the other, to provide pleasing effects on our vision by proper reflection of light and by ingenious devices to prevent the eyes from meeting the glare of the source of light, without materially diminishing the illuminating effect.

Discussion.

The President—We have in these two papers food for a good deal of discussion. Some of the other gentlemen who have previously considered and made experiments in this matter ought now to be heard from. We would like to hear from Mr. Boardman about his experiments.

Mr. Boardman—When I presented that experiment it was with a view to place this matter before you, so that if you wanted you could think over it and work it out. If I had done no more than to call forth the experiments presented here by Mr. Humphreys, I would have been more than repaid for the trouble taken in bringing the subject to your attention. My statement was simply a *recollection* of the experiment. When Mr. Humphreys wrote to me, asking for further explanations, I had to tell him that it was an experiment made some ten years previous. I also told him that, in the experiments with regard to the candle power determined by the student chimney, of course the actual candle power shown by the photometer was not that of 23 but of 22 candles, the result secured after making the necessary corrections for the decreased amount of gas burned by the argand chimney. The same amount of gas cannot be burned in the argand burner with the student chimney as with the straight chimney. But, even with the lesser amount of gas, I got a much higher intensity in the light, and it struck my eye so pleasantly that I thought I must have gained very largely in the illuminating power of the gas. The paper called to mind that I did not make that statement clear in my paper. I think I was on the right track when I cautioned the Association against searching for an intense white light of small size, and giving up the broad flame, with its warm, yellow light. Doubtless, Mr. Humphreys' experiments have impressed that fact more fully upon you than did my statement. I think you will all agree that the water gas flame, as generally burned, is of smaller area than the coal gas flame as usually burned. I would like to have Mr. Humphreys carry his experiments further, and compare the area of the flame of the water gas in the star burner with the area of the coal gas flame of the argand burner, exposed to the disk, showing the approximate sizes of the flame, so as to determine if there would be any difference. I would suggest, if this matter is carried further, that experiments of that character be made. I trust the subject will be pursued to as great length as possible.

The President—We have with us to-day one of our Honorary Members, and one whom we do not see very often—a gentleman who has given the subject a great deal of attention, not only with regard to the gas flame, but also with regard to the electric light. I know I express the wish of every member when I say that we shall all be glad to hear from President Morton on this subject. (Applause.)

President Morton—There are one or two points that have occurred to me in connection with the papers just read which it may be of interest to draw the attention of my fellow members to. These are, in the first place, the very common misconception as to what we mean when we speak of a light ray. People very often speak of a light ray as if the source of light were giving out certain lines of something. Now, the real meaning of a light ray is the direction in which the action of the light is propagated. There is nothing there. In other words, the light ray is not a thing. It is not true that something in the form of a right line, or a straight line, is passing out from the source of light, any more than it would be true to say that the path of the cannon-ball is a line consisting of anything, or being constituted of anything. It is the direction in which the cannon-ball goes.

What, then, is light, so far as we know it? It is a vibratory motion in the elastic medium pervading all space and most bodies. Now, when we have a source of light (suppose for the moment that it is a point), and we say that it emits rays of light, what we really mean is, and what is the fact, is that that point is in effect expanding and contracting or moving in such a way as to produce succes-

sive waves or shells of motion—little spheres, as it were, or a series of spheres. Imagine for a moment that the luminous point suddenly grew large and then small again, whereby it produced a wave or shell of motion. Now, that minute shell of motion produced around this point acts upon the medium outside of it, producing a larger shell of motion; and that again upon the medium outside of it, and so on, just as you might imagine a soap-bubble blown from a point expanding and growing larger and larger as it spreads out. So this first momentary action of the light produces a shell, as it were, of motion, which spreads out equally in all directions. If the source is a point it spreads in every direction, getting attenuated as it spreads. This illustration is, of course, not intended to be exact as expressing in detail the motions of light waves, but as a rough physical illustration it strikes me that it is not, perhaps, a bad one—if you will bear in mind that it is not to be carried too far, and that I do not want to say that a light wave is a substance at all. Imagine a bubble produced from the end of a little pipe and expanding until it fills the whole room. Now, that bubble, at the first instant, contains only a certain amount of substance, and that amount has got to be spread thinner and thinner as it grows larger and larger; so, that if it is twice as large in diameter, a given area of it will only have a quarter as much substance in it. Now, in the case of light, the motion is not in the line in which the force proceeds, but at right angles with it. In other words, if a light ray were passing from this light overhead down on the stage, the motion of the light (the vibrations) would not be in that line, but would be at right angles to it. The particles would be moving at right angles to the direction in which the ray traveled. But that is immaterial in any general consideration. It only becomes important in connection with some recondite subjects, as, for example, that of polarization of light; but in the present case it is immaterial, since we are only considering the subject with reference to the diffusion of light.

Now let us see if we can get a clear idea of what is taking place where light is being emitted by a luminous body. Suppose, for example, that the luminous source is a point emitting these successive shells of motion one after the other, just as if it were a little bubble which was able to expand and spread through the whole building, and then another bubble came right after it, and so on, following each other so quickly that they followed each other at a distance of a quarter of an inch, one bubble within another, and each one expanding continuously through space. That being the condition of things, it follows, as a physical necessity (as a thing the contrary of which is not supposable), that the intensity of that action should diminish with the square of the distance; or, for example, that if the distance is double the intensity or the amount of action on a given area should be one-fourth at the double distance, or at treble distance one-ninth, and so on. This is as necessary as the conclusion that the half of a thing is equal to the other half, or that if a thing is divided into fifty equal parts, each one of those parts will be one-fiftieth of the whole thing. There is no getting away from that reasoning, and if we find that the result of an experiment seems to differ from this, we must be quite sure that there is some error in the experiment. Some time ago there was a very curious trick with a chess-board, which consisted in cutting the chess-board in a certain way and then so putting it together again that out of the 64 squares which exist in a chess-board you could get 66 or 62, according to the way in which the pieces were arranged. Any one looking at that, although they could not explain how the trick was done, yet could be perfectly certain that the two squares were not created or destroyed. So, in this case, if it seems to us that the law of inverse squares in the case of light is not fulfilled, we may be sure we have misunderstood the experiment, or that there is something which we have not taken into account.

Now, suppose that instead of being a point, the source of light were a surface. Then, in the first place, it is manifest that the surface may be divided into an infinitude of points, and that what is true of each one of the points must be substantially true of the entire thing. We cannot have a thing true of each one of a number of individuals, and not true of them altogether. Therefore, if this law is true as to points, it is true of the surface; but in the case of a surface this difference would come in. While each point is giving out rays in this way, in various directions, if we are supposed to look obliquely at this surface, then it is possible that its area is foreshortened, and in effect made smaller than if we were looking at it at right angles. On that account this area will seem to produce less light under certain conditions. If it is a broad, transparent surface which is giving light, and if there is no obstruction of the light by the luminous particles themselves, then there will be no difference whether we look at the surface point-blank or otherwise, for we will still get the same amount of light from it. That is illustrated in certain flames of thin, transparent character which will give us the same amount of light, whether looked at sidewise or frontwise. A number of the experiments just described by Mr. Humphreys illustrate this very admirably. But, if we are dealing with an opaque surface, so that one point can obstruct the light coming from another point, then the light will appear less when looked at obliquely. But that will be only under those peculiar conditions, and it will not be in violation of the general laws of light, but will only be a result of special condition of the particular source of light under discussion, which introduces a new factor or element—that of the obscuration of the light from one point by the presence of some other point of the luminous substance. Let us now consider light emanating from a central source in another way—namely, as a

series of waves moving at right angles to their direction of progress. Such waves would be represented by a wave-shaped line, or, more properly speaking, by a sinusoid curve. They have two prominent characteristics—wave length and wave amplitude or intensity. Wave length depends upon the number produced in a given period of time. That is to say, if they are producing red light, it is because there are about four hundred million million of up and down movements to the second. Four hundred million of million would make the light red. If the motions of all of them were about eight hundred million of million to the second, they would then be producing violet; and between these limits there would be all the various colors, according to the numbers of vibrations. Now, whether there are four hundred million million or eight hundred million million of vibrations produced in each second, they will travel at the same rate. The first one produced will be carried in a second to the distance of about two hundred thousand miles. Whether this motion is made at the rate of four hundred million million in a second or eight hundred million million, it will equally soon get to this distance. At the end of a second, therefore, the wave produced at the beginning of the second will be 200,000 miles off, and between that distant point and the source of light there will be about 400,000,000,000 of other waves which had been produced and started out after the first, one after the other, during the second if the source of light was red; or in other words, if the light emitted was red light. If there were four hundred millions of millions of waves in a length of 200,000 miles this would make each wave about one-forty-thousandth of an inch long. If the color of the light was violet there would be about twice as many vibrations produced in the second, and thus twice as many waves in the length of 200,000 miles, and so each wave would be about half as long. The distance longitudinally between one wave and the next is the wave length of light. That is what makes the difference in color. If there are so many to the inch, or each is such a fraction of an inch, it is one color; if it is a different number, then it is another color.

Now comes the question of intensity. If we say that a light is a very bright one we do not mean that it throws out more waves to the inch, or that the motions are given with more or less rapidity; but we mean that each one swings further up and down; and the intensity of the light would be represented by the extent of this motion up and down. In other words, by the height of the waves. We may say that a dim light would be represented by a motion going up and down, say the one-hundred-thousandth of an inch. A picture of this would be a line almost straight, but waving up and down a very little way every forty-thousandth of an inch. If it was a bright light of the same color it would be represented by a curve, with just as many bends in it to the inch, but they would go up and down much more than the other. It would be a steep wave, as distinguished from the other. This also leads us to the same conclusion, that as this motion spreads outward from the center it must decrease in intensity. That is to say, the height and fall of these waves will diminish. A certain amount of something is put in motion in the first instance, and as that motion is spread and goes outward it acts upon a larger and larger area of the substance, and must, therefore, produce less and less effect. Thus the little ring or sphere whose atoms are moving up and down through a large distance will become a great sphere, whose particles are moving up and down through very small distance.

What I wish especially to bring to your attention is this idea that if we want to represent a light wave philosophically, as coming from a source, we will represent it as a curve which begins steeply up and down, but with a given length between the convolutions, and goes on with this constant longitudinal length, but decreases in amplitude, or the height and depth to which it goes, and so decreases very rapidly—in fact so that this amplitude or height of the wave varies inversely as the square of the distance from its source. The length of the wave, however, or the distance between one bend and another in this sinuous line, will be constant for each color. White light being a mixture of all colors, we have in it the result of the combined action of a great many wave lengths; and, therefore, it becomes a very complex thing to think of or discuss. We need not, however, go into this at present, but may rest in the broad conclusion that what is true of each wave length or color is true of the compound of all colors, namely, white light.

There is one point in the last paper read to which I think it would be interesting to draw your attention, and which was no doubt thought of by the reader of the paper, but not mentioned by him; and that is this: Why is it that with greatly increased intensity of light the visual impression is so little increased? In the first place, the law of Fechner referred to could not have been in reference to the illumination of a surface, because Fechner and others, among them Dr. G. W. Draper, of New York, had proved that the eye can detect a difference of illumination equal to the one-sixty-fourth of the greater light, but must have been in relation to the effect of intense light upon the eye—of a brilliant point or area of light examined directly. In fact, he could not assert that by having two candles instead of one you only light up the table, or the book you are looking at with a slight increase (say 25 per cent. more) of illumination; but that if you doubled the actual luminous intensity of a candle flame and looked at it, you would not be aware that it was doubled, but its effect upon the eye would only be an increase of 20 or 25 per cent., as the case might be. What is the reason of that? I believe it to be as follows: The reader of the paper spoke of the pupil of the eye as a diaphragm through which the light passes into the eye. Let me now add that this pupil of the eye

is an *adjustable* diaphragm. When you expose the eye to a strong light the aperture in the pupil shrinks up. You can see this action with the aid of a mirror even in your own eyes. You can see it better by looking at the eyes of another person. If you bring a bright candle near the eye the opening of the pupil grows smaller. This is very marked in the eye of a cat, where the closing is only from two sides. In the human eye it closes all around. It merely makes a smaller circular aperture. The pupil in the cat's eye spreads out in the dark, making a round aperture, and then closes up to a narrow slit as it contracts in the light. The result is that, while you are looking at a dim light, this aperture is wide open, letting a great amount of light get in through the open pupil and fall upon the retina. As the light becomes brighter and brighter the aperture shrinks up, and correspondingly closes out the light. The resultant effect is merely the difference between the two. If the closing up was as rapid as the increase there would be no difference perceptible between a dim and a bright light. In judging of amounts of illumination in apartments we must not forget this physiological action just noticed, by reason of which the eye if exposed to a very brilliant light will become less able to perceive a feebler illumination, and, as a consequence, the brighter light will appear to illuminate things more dimly, because the eye has changed its capacity of perceiving. But, this should not discredit the quality of the light, but only indicate that we have not been judicious in our location of it.

The President—I would like to ask President Morton whether he would give us to understand that all lights which on the photometer would measure equally would really be equal illuminants in a room? In other words, whether you would get as much light from a 16-candle Edison light as from a 16-candle bat-wing burner. Theoretically, I suppose you would.

President Morton—Theoretically, and as matter of fact “objectively,” using that word in its technical sense. That is, there would be as much light in the room; but to a person coming into the room it would not appear so well illuminated, and for this reason: If the room were illuminated with ten Edison 16-candle lamps, then there would be scattered around in that room a number of very minute spots of light, of intense whiteness. Wherever the images of those struck the retina of the eye they would have a relatively paralyzing effect upon it, and would also cause the pupil to contract. If that same room were illuminated with ten gas flames of large size, then, as one came into that room, he would not find such intense local spots of light; for although there would be the same amount of light from each lamp it would come from a larger area, and would be correspondingly less intense, and the nerve located in those parts of the eye on which the images of these flames fell, instead of being violently shaken by the intense vibration, as they would be in the case of the Edison light, would be more gently vibrated, and this paralyzing or diminishing effect, this dulling of the nerves, would not take place to the same degree, nor would the contraction of the pupil be so great. It is just as it is in coming into a room with the naked gas flames all about you, as compared with the light from the same flames in globes. We all have noticed the pleasant effect of the light upon the room when globes are used. The illumination seems much better with globes than with the more intense light from naked burners. I remember a case where the principle here considered was made strikingly manifest.

In Philadelphia, many years ago, in the Academy of Music, it was found that the stage, which was an extremely wide one, was not sufficiently lighted in the middle by the border lights. Some one suggested that the trouble would be very easily corrected by getting two movable chandeliers, and setting them up on either side of the stage, with a number of gas lights on them. This was done, but only with the result of making the stage appear much darker than before, the reason being that as people looked at the stage their eyes were dazzled by the brilliant light coming from those two great chandeliers; the pupils of their eyes contracted, so that a person standing on the middle of the stage was not so easily seen as before the great lights were put on.

Mr. Gilbert—I would like to ask President Morton a question with regard to the probable practical effect upon the eye of continuous changes in the strength of illumination to which people are exposed nowadays by the necessity of living in extremely brilliant lights; and whether turning the back and then the face to brilliant lights of any kind, and so producing rapid, constant, and unnatural changes in the pupil of the eye, does not tend ultimately, practically, to destroy it?

President Morton—There is no question but that such changes are very trying to the eyes. No one can realize that better than while passing through the tunnel of the New York Central Railroad. If one sits with his eyes open while going rapidly through the tunnel, the effect, as they pass the light shafts, of the rapid changes from light to darkness, is, with most persons, extremely painful. That of course is an exaggerated case; but any sudden and rapid change must be very injurious to the eyes. Burners that flicker, from which the flame jumps up and down, are undoubtedly very severe and dangerous things to the eye. There is no doubt that the present generation are risking their eyesight by the use of so many brilliant lights.

Mr. Graeff—Does President Morton mean when stating that the candle power of the Edison light is equal to the candle power of the gas lamp, if there were a dozen Edison lights at our back they would illuminate the space in front of us as well as would a dozen gas burners? In other words, what I wish to ask is whether candle power is exactly the same, without consideration of its effect upon the retina of the eye.

President Morton—If this candle power, properly measured, is the same, then undoubtedly the illumination of a surface would be identical. In other words, it would be almost stating the same thing in two ways. When we say that the candle power is the same we mean that, on testing with the photometer, and allowing the light to fall on a white surface, we get equal illumination of that surface. If it is true in the photometer it cannot be otherwise than true out of the photometer. It is not the photometer that makes the light.

Mr. Boardman—I would like to speak on that point one moment, because of the evident misapprehension which seems to be in the minds of some with regard to the transmission of illumination, as indicated by the photometer. While practically, as President Morton says, the illuminating effect on the space must be the same, still I must contend that the illumination of space, as we usually inhabit it, is somewhat different. I must contend that as we inhabit space we are certainly all objects of three dimensions; and that any light proceeding from a fixed point does not illuminate so much of the surface—of a column, for instance—as it does if that light proceeds from a plain surface of two dimensions. And, therefore, that the space which is partly illuminated by reflection from that column is not so well illumined as it would be from a surface throwing light upon it, and lighting a larger surface than that, and then reflecting from that to other surfaces. That is the point that I wish to bring out in respect to the use of large surfaces for illuminating the space which we usually inhabit. That is what we have to contend with. We are to light the rooms that we occupy, and the halls in which we meet. We want those lights so distributed that there shall be as little shadow as possible, and that each object in the room shall be as nearly as possible illumined all around, so that the reflection from them may help to illumine other objects which do not get the direct rays. For this reason I respectfully contend that the illumination of the space we inhabit is greater with the flat-flame burner than with the Edison light.

Mr. Clark—I think the proceedings of this year will be very rich in information concerning light—both theoretical and practical. I think we should be specially grateful to Mr. Humphreys for having settled this question of diffusion, as it is one which has vexed us a good deal. The papers are of such a character that it is hard to discuss them off-hand. We will enjoy them very much when reading them, but we cannot readily discuss them on short notice. They are too deep for us.

Mr. Lowe—I would like to ask President Morton a question. If you were to take two flames of equal intensity—for instance, a yellow flame of 20-candle power and a white flame of 20-candle power, and take a given area of each, say one square inch—what would be the difference, if any, in the illumination at equal distances?

President Morton—If they were equal at one distance they would be equal at all other distances. That is to say, if they were tried, as in the experiment described by Mr. Humphreys. If we had a yellow flame here, and a white flame there, and so adjusted their relative strengths that they gave equal illumination upon a surface intermediate between the two, then if we moved them both equally away from the surface, the illumination would remain equal on that surface.

Mr. Lowe—Notwithstanding the color of the light?

President Morton—Notwithstanding the color.

Mr. Lowe—Then you do not think that a 16-candle coal gas is better than a 20-candle power water gas?

President Morton—No; I should not think so, as a matter of mere illumination.

Mr. Boardman—In testing the candle power of different flames, did you ever observe the relative size of those flames necessary to give the candle power?

President Morton—Yes.

Mr. Boardman—Then I should like to ask whether the yellow flame requires a larger surface or a smaller one, or a surface of the same size, in order to give the same candle power by the photometer?

President Morton—The yellow flame undoubtedly requires a larger surface to give the same amount of light as compared with a white flame. In other words, a white flame, from the nature of things, has a more intense action. And that reminds me of a point which I think will interest you. A great many years ago Prof. John W. Draper, of this city (now dead), who was one of the most original of American scientists, went into this subject and investigated it thoroughly. He found that where a body was rendered luminous by heat, as, for instance, a platinum wire, this was the order in which the colors appeared: When it first became luminous the rays were entirely red; as it became more luminous, there were added, to those red rays, yellow rays; but the red rays were also increased. There came more red light than before with the yellow light added to it. Then, as the heat was increased still more, the red was increased, the yellow was increased, and there was added to them green rays. As the heat was still further increased there was added to the green, blue; and to the blue, violet; but, with each addition of the higher colors, the amount of the light of the lower colors was increased. In other words, we find that in order to get up to such a compound of colors as will give us the white light—that is, a compound which must have in it blue, and violet, as well as the others—we must have a great amplitude of motion or intensity of the lower ones as well as of the higher. In still other words, when we get the white light it is by having a very intense, or very powerful vibratory action, or the amplitude of the longer waves must be great in order to bring the shorter waves out so as to produce white light.

The President—I do not see that there is very much left for the adherents of coal gas, theoretically; but I think that some of us are still unconverted. It seems to me, to put the thing in this way, that, theoretically, if you will take 5 feet of 30-candle gas you ought to get from it as much light as you would from a larger burner, burning 10 feet of 15-candle gas; or as you would get, from the same amount of gas, from two of these Edison burners. Now, as matter of fact, I believe that if you should compare the light upon a surface which was lighted by a large flame burning 10 feet of coal gas, with that lighted by a flame which was burning 5 feet of 30-candle gas, you would find the room would be better lighted by the 10-foot burner. It seems to me there would be more diffusion in the room; although, theoretically, I do not know that I have any reason to give for it except the size of the flame.

President Morton—I think you are correct, theoretically as well as practically, up to a certain limit. In order that a gas with half the intensity of illumination should produce the same total amount of light, there must be a double area by which the light is produced. That, of course, will diminish the sharpness of the shadows. When we are speaking of single lights it is manifestly true that if you have a light which is one square inch in area, and are getting from that a certain total amount of light, and then get the same number of candles from two square inches of light, the intensity must be diminished proportionately; half the intensity involves double the area. With this double area you are getting a better diffusion; it will go more around the columns; it will better light up spaces that otherwise would be shaded; it will diminish sharpness of the shadows, etc. That is undoubtedly true. In practical illumination, however, we are dealing generally with a number of lights. It is very rarely that we attempt to light a room from an absolutely single source. Where we are dealing with a number of lights, and multiply the number of lights when you reduce the intensity, then we are gaining in both ways; because, of course, it is easier to light a space by putting two lights a quarter way from each end than by lighting with one light in the middle, for this law of decrease in proportion to the square of the distance makes it disadvantageous to light from a single source. In any case in which distribution by breaking up one light into several comes in, of course there is great advantage in a number of sources of light as compared with a single one. But I do not think, aside from this, that there is a difference if a given area (say a square inch) is given, of 20-candle power, and that light is falling on a plain surface, and another of two square inches, which is also giving off a 20-candle light, which falls on that same surface. Then I cannot conceive that there can be a difference of illumination, except such as may be due to the different colors of the lights. One may illuminate with a pure white light; another may illuminate with a yellow or reddish light; and one or the other may be agreeable; and one or the other may light a surface, if it is a colored surface, very much better than the other. If a majority of the objects are of yellow color, a yellow light will illumine them much better than any other color. If those same objects were blue, then a yellow light would be feebler in its illumination. If we had a room of more chromatic color, all red or all yellow, we could then best light that room with a light of a corresponding color; but, if a room is decorated with all sorts of colors, then the whitest light that we can get—the nearer in fact we can approach to daylight—the more distinctly all the colors will equally appear.

Mr. G. Wood—There is one point I would like to introduce here. Some years ago a party came to New Bedford, Mass., who wanted to light the city streets with oil. He said that he could produce a light better than the gas light produced by a 4 foot burner, and could do it a great deal cheaper—so much so, that it took the mind of the Committee on Street Lighting, and they adopted the plan for a year instead of using gas. Some of the citizens said that the streets were better lighted with it than they had ever been before, but we soon determined that they were not so well lighted as they had been with gas. Perhaps we were a little selfish about the matter. However true or not the latter may be, we tried to get one of their lanterns in order to test the light in comparison with gas. They would not let us have one. We used a little stratagem, sent on to New York, and by reason of passing the order through two or three individuals, without their knowing where the lamp was to go, we obtained a lantern and also secured a quantity of the oil they were using in the lighting of the city. We put that lantern up in a building, lighted it, and then started up one of our gas lights close by. We next invited the Committee on Street Lighting to pay us a visit. On entering the building they first saw the oil light, and then looked at the gas light. They said right away that the oil light was the best. Then we tried the lights with the photometer, and found that while the gas light, burning 4 feet, was giving a 13-candle light, we could only get 7.5 candles from the oil light. Any unprejudiced person could see, simply by looking at the two lights, that the photometer told the truth; but the Committee declared that the oil gave the best light, and we were likely to be defeated in our contest. I finally said I wanted them to make a simple practical test. Taking out of my pocket a small almanac which was printed from small type, I asked them to read that print at as great a distance away from the oil light as they possibly could, and then to go through the same process with respect to the gas light. They tried both suggestions and found they could read the print, by the aid of the gas light, at twice the distance possible by the aid of the oil light. They all tried it, and all reached the one conclusion. Then they gave up the contest.

Mr. Edgerton—I understood that the starting-point of this dis-

cussion was the assertion that 16-candle coal gas illumined as well as 20-candle water gas. I desire to call your attention to a practical illustration—a case of illumination in London, England, where they have a 20 or 21 candle cannel coal gas and a nominally 16-candle common gas; and yet, as a practical test, the cannel gas is sold at 4 shillings, whereas the common gas is sold at 2 shillings and 3 pence.

On motion of Mr. Clark, a vote of thanks was tendered to Messrs. Humphreys and Jones for their papers.

Mr. A. C. Humphreys—I wish to say, before moving a vote of thanks to President Morton, and before the discussion on this subject is closed, that last night I made a practical experiment, not a scientific one, in my own room with two light-giving surfaces, one being perfectly white and the other being a very mellow yellow. I tried with the photometer to test the illumination from the same candle power. So far as I could see, they were of the same size, made from the same materials, and practically the same. The lighting effect in the room, as we speak of it, from the yellow flame appeared superior, as it certainly was more pleasant to the eye; but when I asked some of those with me to read print at a certain distance from the light, they could read it with the white light the best.

I move the thanks of the Association to President Morton for his very interesting remarks upon this subject. I regard them as a practical lecture, covering some very important features, and I think that, if we deserve thanks for our papers, President Morton most certainly deserves our thanks for his address.

The President—I understood that in voting the thanks of the Association, we included all three of the gentlemen who we had the pleasure of hearing, but I am very happy to put a motion tendering a special vote of thanks to President Morton for his entertaining remarks.

The motion prevailed.

Mr. C. H. Nettleton, of Birmingham, Conn., now read his paper on the subject of

UTILIZATION OF RESIDUAL PRODUCTS.

Unfortunately the Committee appointed by your Association to appoint certain members to prepare papers for this meeting selected the speaker as one of the victims. It was unfortunate in a double sense for the Association, as a better selection could easily have been made, and a far better paper been listened to than the one you will now hear; and unfortunate for the speaker, as the press of business has been so great with him this fall that sufficient time could not be spared to give the subject named by the Committee the thought necessary, or the few thoughts he had the proper expression. I dislike to offer the Association an apology after promising to write, but it has been impossible to prepare a paper worthy of the subject or the occasion.

The notice which I received from our Secretary stated that I had been appointed to prepare a paper on the "Utilization of Residual Products to cover the probable return, not only in my own immediate neighborhood, but from other sections as well."

While thanking the Committee for the compliment implied by the appointment, yet it has seemed to me that they laid out a very large subject for one person to write about—so large that the time at my disposal did not warrant the undertaking, and in consequence I have ventured to change the subject somewhat, and shall treat simply of the Residuals of a Coal Gas Works.

What I desire to call your attention to is not so much the value of residuals in themselves—with that you are all familiar—but to the probable revenue that can be derived from them; to the necessity of paying a large amount of attention to their sale, and to point out some methods followed successfully by some companies with which the speaker is familiar in disposing of these bye products. In the first place, what can be derived from the sale of residuals in a coal gas works? It is a fact that in a large European works the entire cost of manufacture is paid for by profits derived from the sale of coke, tar, and ammonia water, and their products, so that the gas in the holder costs absolutely nothing.

At the other extreme is the small works poorly managed where the tar runs into a convenient sewer or river, where nearly all the coke is used in heating the retorts, and where at the end of the year the total returns from residuals amount to fifty cents per ton of coal carbonized, or less. Between these extremes there is a wide margin. Few of us, perhaps none, can ever expect to reach the high results of the foreign company referred to, but all of us, it is to be hoped, make a better return than the last named.

How shall the sale of residuals be expressed? If in so many hundreds or thousands of dollars, it means nothing unless the size of the company be known. If in so many cents per thousand feet, the statement is misleading, for the reason that the price received for coke, which is by far the largest item, must depend entirely on the local price of fuel. For illustration: Suppose A is the manager

of gas works in a city where the cost of the coal for domestic purposes is \$6.50 or \$7.50 per ton—he may be able to obtain 11 cents per bushel for his coke, and if he sell 15 bushels per ton of coal carbonized, the receipts would be \$1.65. B, on the other hand, manages a works where good coal for domestic purposes is sold at \$2. He sells, let us say, 25 bushels per ton of coal carbonized, but can receive at most but five cents per bushel, or \$1.25. If expressed in thousand feet sold, and each sells 10,000 feet per ton, A would receive 16 1-2 cents per M. and B but 12 1-2 cents, and yet B manages to sell 67 per cent. more coke per ton than A.

It seems to the speaker that the proper way to express sales of residuals is in percentage of cost of coal carbonized. This gives an intelligent statement at once of the results reached, and enables us to compare results with others in the fewest words, and in the most comprehensive manner possible. The coal has cost one hundred per cent., the returns from residuals are fifty, sixty or seventy per cent.

In the case of A and B referred to before, A would probably pay \$5.50 per ton for his caking coal, for with high prices for domestic coal, gas coal is almost invariably correspondingly high, and vice versa, and his receipts for coke being \$1.65 per ton would be thirty per cent. of cost of coal carbonized. B, on the other hand, would undoubtedly purchase his coal for \$2 or less—and his receipts being \$1.25 per ton, would be sixty-two per cent. I submit to your judgment if these percentages, thirty and sixty-two, do not more nearly represent the comparative working of the two managers, so far as relates to coke, than can be expressed in any other way.

Let me say frankly that I started in the preparation of this paper with the hope of proving that in most works well managed, the residuals could be made to pay 90 per cent. of the cost of the coal; but here on the seaboard, and through New England, with good caking coal costing from four to five dollars per ton, I have very reluctantly come to the conclusion that most of us must content ourselves with 70 to 80 per cent.

But what does this mean in this part of the country? Let us assume that the cost of coal including cannel or other enriching material is \$4.30 per ton in the coal shed. Seventy per cent. of this will bring an income of \$3 from each ton carbonized, and if the capital be no larger than \$60 per ton of coal used or \$6 per thousand feet sold, the income from residuals will pay 5 per cent. on the capital.

Can this standard be reached under ordinary conditions? I believe it can, and the fact that better results than 70 per cent. are obtained at one works on the seaboard here, and results reaching closely to 100 per cent. in a Western city where cheaper coal is obtained, ought to be all the proof needed that my statement is not exaggerated.

In the order of value the residuals can be named coke, tar, and ammonia.

First—Coke, and how much can be obtained from it? The answer to this depends on the quantity saved, the rapidity with which it is sold after being made, and the price received.

First—The quantity saved. This in turn depends on the settings for the retorts, and whether regenerative furnaces are employed. All will agree, I think, that no gas manager can afford to use a poor setting or a poor stack; the waste of heat and consequent waste of money are too great; but all may not agree with the desirability of using regenerative furnaces. After an experience of seven years, I unhesitatingly say that I am strongly in favor of these furnaces, and one of the principal reasons is the larger amount of coke left for sale than with the ordinary setting. It is well known that certain gas works using furnaces are selling 30 bushels of coke per ton of coal carbonized. The day when a gas manager can rest content in selling 15 or 18 bushels of coke per ton has passed, and 25 to 28 bushels, or higher, must be the standard.

Second—The rapidity with which coke can be disposed of affects to a large degree the quantity, provided of course it is sold by measure and not by weight. If a pile is allowed to accumulate and the coke handled over a number of times, the consequent shrinkage in bulk is very great, reaching, so I am told, to as much as 30 per cent. Coke should be sold, if possible, as fast as made. If customers do not come and leave their orders, then seek the customers; devote time and energy to its sale. Push it with the same enterprise that we use in selling our gas, and the results sought for are sure to follow. I have in my office a large poster which has been used very successfully by a New England Gas Company. With an accumulation of coke in their yards, the bill boards, dead walls, and fences in the city where that company is located are covered

with that poster, with coke and its virtues printed in glowing colors, so that he who runs not only may but must read. The result I am told is invariably the same, the demand increases, and the surplus disappears, and that too without lowering the price.

Third—The price at which coke is sold. It is the fixed belief of the speaker that the same price per pound or per ton ought to be obtained for this product in every place, as is paid in that place on an average, for a good quality of steam and house coal. I believe this because some careful experiments at the gas works in my charge convinced me that a pound of coke would evaporate a trifle more water than a pound of coal, and because (and this perhaps is the most convincing proof) I obtain that price and have done so for years, almost without exception.

The experiments referred to were made in an upright tubular boiler: 7.36 pounds of water were evaporated with a pound of good anthracite coal, and in the same boiler, under the same conditions 7.55 pounds of water were evaporated per pound of coke. Or expressed in dollars—if the coal were worth \$5.00 per ton of two thousand pounds, coke would be worth \$5.13 for the same quantity.

The price at which coal has been retailed in the town in which the speaker lives, has varied from \$5.00 to \$6.00 per net ton for a number of years. And the price of coke has been fixed at nine cents per bushel in the yard or ten cents delivered within a mile of the works for the past six years, and has not been deviated from except on rare occasions. As a Winchester bushel of dry coke weighs about 37.5 pounds there are 53.3 bushels in a ton of 2,000 pounds, and at 10 cents per bushel, the price received for coke must have been \$5.33 per net ton. As the cargo prices, or those at which the manufacturers buy their coal are much lower than the retail prices, I think that the statement made above is fairly proved that the company with which the speaker is connected has received for its coke the full average price at which coal is sold in its neighborhood.

I have been told that the company is very fortunate to be able to obtain such a price for coke, and probably that is a fact; but back of the good fortune lies a great deal of labor, and the price is as much the result of hard work as any other successful enterprise is the result of well directed thought and effort. Besides other companies in New England receive the same or higher prices. Our Secretary can if he will, tell you of one which receives on an average ten cents per bushel for broken coke; a neighbor of his receives about the same price; another exceptionally situated, receives 12 1-2 cents per bushel, and so on.

In selling coke there are a few essentials which to the writer seem quite important. Have a fixed price, "like the law of the Medes and Persians which altereth not." Make it as high as you think the market will bear, and then adhere to it. Nothing will destroy a good coke trade so quickly as a rise in price. Seek a house trade, it is the most reliable in many ways, and can be depended on to last better than almost any other; and one great point in its favor is the fact that it varies in its demand almost directly as our production of coke—being heaviest in the winter, and lightest in summer. To secure this trade it is a matter of necessity to break the coke—without that, the attempt will be a failure, for nothing but a coal famine will force any large number of people to try to use the large lumps of fuel in their cooking stoves, which we haul out of our retorts.

The breaking of coke seems to be quite a bugbear to some of our ablest members—and yet in small works with hand hammers or in large works with machines, the breaking can be done at a very slight expense.

These gentlemen claim that between the labor, the shrinkage and the breeze produced, it would be as well to sell the coke for a very small sum. The answer to this is, to charge a sufficiently higher price for the broken coke to cover these items. The speaker has sold broken coke at eleven cents per bushel in yard, or twelve cents delivered, for a number of years; and from some careful experiments the following results are arrived at:

100 bushels of large coke is worth at 9 cts., \$9.00; when broken it makes 85 bushels small coke worth at 11 cts., \$9.35; and 7 bushels breeze worth for steam, at 6 cts. 42; total \$9.77—leaving an excess of 77 cts. to pay for labor in breaking, which more than covers the cost.

In this connection it may be of interest to relate a personal experience which happened this past year. From some changes in the retort house, a larger quantity of coke was saved last year than ever before, and during the present year a still larger quantity was expected. The question naturally came up how can a market be found for this surplus coke? The factories were tried without

success, and finally it was decided to work up a house trade if possible. Various means were resorted to, posters, advertisements in papers, circulars, etc., till finally a card was sent out in February last, which on one side read as follows:

At the following prices, small coke will be delivered and binned on any floor of any building within one mile of Gas Works:

2 bushels,	\$0.36	14 bushels,	\$1.79
3 " "	51	15 " "	1.90
4 " "	66	16 " "	2.01
5 " "	80	17 " "	2.12
6 " "	91	18 " "	2.23
7 " "	1.02	19 " "	2.34
8 " "	1.13	20 " "	2.45
9 " "	1.24	21 " "	2.56
10 " "	1.35	22 " "	2.67
11 " "	1.46	23 " "	2.78
12 " "	1.57	24 " "	2.89
13 " "	1.68	25 " "	3.00

The results can be stated in a few words. From March to September inclusive of 1886, 74 coke orders were received at the office, representing 2,930 bushels, and in the same months of 1887, 448 orders were received representing 9,293 bushels, and besides a larger quantity has been sold from the yard. So large has been the increase that it has been necessary to purchase some coke from a neighboring gas works in order to keep up with the demand. In this connection it can be stated that a careful account has been kept of the cartage. The excess on the prices quoted, above 11 cents per bushel have been credited to the carting, and it can be stated positively that no money is lost on that account.

Tar.—The question of how to dispose of tar to any profit is a very difficult one for many companies to answer satisfactorily. It is well understood that to put up a tar distillery, and run it successfully, needs a product of such an amount that few works in this country can undertake it. The tar can be sold to the tar distillers, who of course have to make a profit, and in consequence can offer only a small sum, small compared to what we would like to obtain; or it can be sold to rubber factories to be made into "pure gum" shoes; or to the electric light carbon factories to stick the particles of carbon together; or it can be sold to the tar-walk man. But all of these, except the last named, involve transportation charges, which must in the long run be deducted from the price received for tar. It is desirable to have a home market for everything pertaining to a gas works, and that is especially the case with coal tar; without it a small amount only will be received for this product—with it a price can be obtained which will net the company from 50 to 75 cents per ton of coal carbonized. All through the western part of Connecticut tar side walks are very popular, and in some towns, stone or brick are the rare exceptions. As this makes the most desirable market that I have ever heard of, a description of the method followed in laying the walks may not be out of place, and may be of some assistance to the gas manager who has no market for his tar.

The space to be covered is leveled off about 3 1-2 or 4 inches below the grade of the walk and rolled, and if bordered by grass or desired to be confined, a board 1-2 inch thick and 6 inches wide is set up on edge along the sides. If the ground is of a sandy or gravelly nature, this is all the preparation needed; but if of loam, the soil must be excavated to the depth of two feet and the space filled in with stone, gravel, cinders or sand. If this is not done the walk when laid, will be sure to crack, and heave when the frost comes out in the spring. The material is prepared as follows:

If a gravel bank be convenient, stones from 1 inch to 2 1-2 inches in diameter are carefully screened out, tar thrown over them and the pile turned over, so that each separate stone shall receive its coating of tar. These are laid on the space which is already prepared for the walk, to the depth of three inches. They are then rolled with rollers weighing three hundred pounds and upward. Care should be taken that sufficient tar be used to cause the stones to stick well together, or otherwise the walk will disintegrate. The speaker has never seen it tried, but is of the opinion that broken stone would make a better walk than the round cobble stones which are generally used in Connecticut, as the rough surface of the broken stone would make a better surface for the tar to adhere to than the smooth surface of the round stones.

The "top-dressing" is prepared as follows: Coarse, sharp sand and fine coal ashes are mixed carefully together "dry," in the pro-

portion of one part of ashes and two parts of sand. The tar is then added, the pile turned over a number of times, each time being carefully raked, so that the tar shall thoroughly permeate the entire mass. Care must be taken not to use too much tar, as in that case the walk will be too soft; and on the other hand, if too little be used, the particles of sand will not adhere to each other. When thoroughly mixed the pile should have a dry, spongy appearance. This is now laid evenly on top of the first course to the depth of an inch and a half. It is then carefully rolled and the pressure of the rollers will reduce it to one inch in thickness, or a trifle less. The walk is allowed to stand for twenty-four hours without being used, and is then ready for public travel. The prices asked by the tar walk men vary from fifty to ninety cents per square yard, but it can be truly said of the quality that the walk is very apt to vary with the money. If the former price be paid, a walk will be laid that will last for a few years only, for the latter a walk *can* be laid that will last 15 or 20 years with ordinary use; and then for repairs need only have a renewal of the top course.

The speaker has found it necessary, in order to sell tar for this purpose, to divide that produced at his works into two qualities. All condensing in the hydraulic main, and hot tar scrubber is sent into one well, all beyond that point, in the exhauster, condensers and standard scrubber, into a separate well. For the first he has had no difficulty in obtaining \$3.00 per barrel, for the second \$1.50 per barrel, averaging \$2.50 per barrel, each holding fifty gallons.

If my company had no demand for tar, and could not develop one which would bring a fair price, I should certainly burn it. Tar is worth to burn under the retorts one-half the price of a bushel of coke, and that fixes the price under which I will not sell it, so long as the matter is left in my hands. If all the gas companies in the country could be induced to act on this idea, and one-third or one-half of the tar produced were consumed under the retorts, there would be little difficulty in obtaining a reasonable price for the balance. As you know this course is recommended, and practiced by one of the leading gas engineers in England, Mr. George Livesey, and I would commend it to the careful consideration of every gas manager who fails to obtain a good, round price for his tar product.

Ammonia.—Until very recently most of those present allowed their ammonia water to run to waste, but thanks to some of our friends in the ammonia business, a plant has been developed in the past two years for concentrating ammonia water with very little trouble, and at slight expense, from 7 or 8 ounce liquor to 60 and 70 ounce strength. By this means a great weight of water is gotten rid of, and it is now possible to ship the concentrated at a profit, where before the freight charges would have left the balance on the wrong side. By this apparatus, companies carbonizing 1,500 tons annually or even less, can obtain a return from this residual. The cost of operating the concentrating apparatus belonging to my company is:

For labor per day, not over,	\$1.00
For additional coke used in boiler, 5 bushels at 9 cts.,	45
	\$1.45

In addition to this some additional breeze is used to make the steam required, but it has not been included. There are besides the items of interest, depreciation and repairs. A run of eight hours will work off 600 gallons of 8 oz. liquor, and will produce about 75 gallons of 60 oz. liquor. This will weigh about 650 pounds, and can be sold at prices which will vary with the location of each place. From what I hear there is no difficulty in a contract being made that will net 18 cents per ton of coal carbonized.

It is proper to state, however, that the concentrator will not work well with less than 5 oz. liquor, and a higher strength gives better results.

And now gentlemen, I have nearly done. I am afraid some of you will think I have been indulging in the possible, and not the probable return from residuals and some replies received from inquirers which are tabulated below, tend to confirm that idea.

	Per cent. of cost			
Bush. of Coke	of coal, cannel &	Price per bush.	Average retail	
sold per ton.	oil rec'd from coke.	in yard.	price of coal.	
1	—	16.78	.07 X	5.75
2	.73 of coke made	50	.05	2.50
3	—	25	.05	5.75
4	22	33	10 for broken	6.25
5	22.63	42	8.77	5.50

As these figures, with two exceptions, do not bear out the opti-

mistic views presented in this paper, and as the weight of evidence is against me, I submit the following table to show the facts on which my faith in this matter is founded.

The sale of residual products at the works in my charge have produced the following percentages of cost of coal and cannel (no oil is used) for the past five years. In all cases the cost of delivering the coke is deducted. The labor of breaking coke is deducted only in part, but at most this item is small during these years. The labor of pumping tar is not deducted, but the labor and all charges connected with ammonia are.

For year ending April 1st, 1883,	47.8 per cent.
1884,	46 “
1885,	57.5 “
1886,	54 “
1887,	57.6 “

As the company is now selling six bushels of coke more per ton than last year, and as this additional sale will add more than 10 per cent. to the figures of 1886, it is safe to claim that the residuals are now paying nearly 70 per cent. of the cost of coal carbonized.

I trust you will pardon the length of this paper. It has grown much larger than I wished or expected—as you probably have discovered it is a subject in which I take great interest, and it is not impossible that I exaggerate its importance; but I feel confident that if the dollar problem which our Mr. Greenough gave us years ago as being the great problem of the day among gas men—if this problem be ever solved in this part of the country, it must be done by working up the receipts from residuals to the highest possible point. With success there the problem may be solved successfully—without success it never can be.

Discussion.

Mr. Pearson—Mr. Nettleton spoke very favorably of the results obtained from the regenerative furnace, with reference to the quantity of coke obtained from a ton of coal. I would like to ask him if he obtains as much tar, and if the tar is of as good a quality as that obtained by him previous to using the regenerative system?

Mr. Nettleton—I am unable to answer that question positively. For years I have been figuring that a ton of coal yields 14 gallons of tar, because my sales bore out those figures. That allows 3 1-2 tons to each barrel of tar, of 50 gallons. I think, however, that with higher heats, a somewhat smaller quantity of tar would be made. I did not notice any difference in the quality of the tar in the matter of its use for tar-walk purposes. The hydraulic main tar is somewhat thicker, and the tar-walk makers think it is somewhat better for their purposes. Certainly they do not complain of it and it is being used very generally in my neighborhood.

Mr. Pearson—You do not speak positively as to how much less you obtain; but you think you get nearly as much?

Mr. Nettleton—I think that I get nearly as much, but I cannot speak with positiveness.

Mr. Pearson—Do your tar-walk makers heat the tar before using it?

Mr. Nettleton—In cold weather, when it is impossible for the tar to run, and they cannot work it as they need to do in mixing it with the materials employed, they heat the tar, but in summer they do not.

Mr. A. C. Humphreys—Do they dry the ashes and sand which they use?

Mr. Nettleton—In wet weather they dry the sand, and, I think, dry the ashes; but, as they ordinarily work on bright days, they use the sand just as it comes out of the pit, and the ashes as they come from the cellars, screening out the coarse particles. When they lay pavements over which horses and wagons are to be driven, they put in a lower course of coarse stones, and in the top course use some soft pitch. What percentage of that is used I do not know. For ordinary pavements they do not use the pitch. They merely use the tar, and without heating, except in cold weather.

Mr. Clark—Does not that soften in warm weather?

Mr. Nettleton—If the pavement is laid in the spring it will be somewhat soft the following summer, but by the following year it will be very hard.

Mr. Lowe—Did I understand you to say that a ton of coke is worth 13 cents per ton more than a ton of coal for the purpose of generating steam in boilers?

Mr. Nettleton—Yes; in my opinion.

Mr. Lowe—It seems to me that that touches somewhat the point which the Secretary has been so anxious to hear something about—the generation of steam from coke. Can you give us some idea of that?

Mr. Nettleton—I have given you the results concisely.

Mr. Lowe—Were the price of coal to go down, then the results would be in favor of coal, rather than in favor of coke, as I understand your paper.

Mr. Nettleton—If the prices of coal go down, then the price of coke must drop correspondingly; but the coke is worth a little more than coal.

Mr. Lowe—You stated that the price generally received for this

hard pavement was from 50 to 90 cents per square yard. I have just paid 30 cents for a lot of this work.

Mr. Nettleton—I doubt if that work will last.

Mr. Helme—You will recollect that, at our meeting in Boston, an effort was made by members living west of the "Hub" to have 2,000 pounds designated as the weight of a ton of coal. Mr. Slater does not seem to be here now, but you may recollect that he calculated it for 2,240 pounds. You will also recollect that no two gentlemen connected with New England gas works would agree as to the number of bushels of coke they got from a ton of coal. Is not that so?

Mr. Nettleton—I was not there; but, nevertheless, that is a fact.

Mr. Helme—I will say this, however, some claimed to get as high as 43 bushels of coke to the ton, while others put their estimate at as low as 30 bushels. These figures were so far from what I had been used to obtaining that I did not say anything about it. My preference was for placing the weight of a ton of coal at 2,000 pounds; but 43 bushels of coke, from a ton of coal, was what disturbed me. I know that a resolution was passed to the effect that whenever we were discussing the subject of weights and measures, we reckoned on the basis of 2,240 pounds to the ton, and 2747.7 cubic inches to the bushel of coke. Although Mr. Stiness could make more coke than all the rest of you, he only got 40 bushels of coke out of 2,240 pounds of coal. I do not see how you can get 53 bushels of coke out of 2,000 pounds of coal.

Mr. Nettleton—In answer to Mr. Helme I will say I have used 2,000 pounds to the ton simply because I was comparing the price of coke with the price of coal; and coal is always sold for home use in our city by the ton of 2,000 lbs. I did not say that I got 53 bushels of coke to the ton of coal. I said that there will be in a ton of coke 53 bushels.

Mr. Page—In an address by Dr. Siemens, delivered before the British Association some six years ago, he stated, what was then a fact in the case of one coal gas company in England, that the receipts for residuals—coke, tar, ammonia and sulphur—paid the cost of putting the gas in the holder. Five years ago, when ammonia and ammoniacal liquor of 8 ounces sold in England at an average price of 60 cents per ton of coal carbonized, coal tar was selling at 65 cents per ton of coal carbonized. Therefore, and in the case of many companies, more than the cost of the coal was obtained from the residuals. Why has there been such a change in the value of the two residuals? In the first instance, the vast increase in the production of anthracene and benzole from coal tar, by which the value of the benzole and the anthracene was diminished, and the vast increase in color manufactures in Germany, Switzerland, Belgium and in England, caused so great a reduction in the value of the coal tar dyes that the market price of coal tar fell from 65 cents to the present price in England of about 25 cents per ton of coal carbonized. In this country, singular to state, a larger average price is being obtained for coal tar than in England, because of the wider uses of the products. Pitch is being used so much more largely here for roofing, and for paving, and creosote oil for wood preservation. The light products, to some extent, are increasing in value; but as the values on the other side are so low that it does not pay to export the benzole and anthracene, our manufacturers receive nothing for the latter once very valuable product, the base of artificial madder. Yet, with the advance in chemical industry applied to the use of coal tar products, and to the manufacture of new products on the other side, in Germany especially, where technical schools have been educating their young men in this line for 25 or 30 years, to-day not less than 2,500 bright and intelligent men are employed exclusively upon some one or more of the local tar products.

Professor Baeyer has produced artificial indigo, synthetically, which is being imported, sold and used in this country to-day at \$20 per pound, when the price of vegetable indigo is \$1.50 and \$1.60 per pound. Why? Because it gives a brighter and more distinct color, and, therefore, can be used for certain purposes where the vegetable indigo cannot be used so advantageously. By cheapening the modes of producing it, which will doubtless be accomplished in due time, competition with indigo for all its varied uses will be possible. Then the fifteen or twenty million dollars per annum now paid for indigo will be paid for this product from coal tar, just as to-day the artificial madder has displaced every acre of natural madder grown in the world.

A most interesting discovery has been made in our country, and mainly by a distinguished American chemist. I hold in my hand a sample of saccharin. A letter just received by me from Dr. Ira Remsen, of the Johns Hopkins University, of Baltimore, gives its history as follows:

"The facts in regard to the substance commonly called saccharin, are simply these: During the year 1879 a Russian, by the name of C. Fahlberg, was working in the laboratory of the Johns Hopkins University under my guidance. At his request I suggested to him a line of original investigation, which was a continuation of some work I had previously done, the result of which had been published. He undertook the work and was constantly under my guidance. When the work was completed I wrote and published an article giving an account of the results, and describing the sweet substance under the name of benzoic sulphinide. As is the custom in all scientific laboratories of the world, I placed Fahlberg's name with my own at the head of the article. This kind of partnership is perfectly understood by scientific men. The article to which I refer was published in the *Berichte der Deutschen Chemischen Gesellschaft*, XII., 469 (1879). Afterward, in January, 1880, I wrote a second and more detailed article on the subject, and this was published under my own and Fahlberg's names in the *American*

Chemical Journal, in April, 1880, Vol. I., page 426. Since that time I have, with the aid of advanced students, continued my investigations of the substance, and have published other articles on the subject. In the meantime it appears that Fahlberg has occupied himself with devising methods for preparing the substance and has patented it without consulting me. This I object to; and all who are familiar with the facts recognize that Fahlberg is entirely unjustified in appropriating the results of our joint labors. My opinion is that he has acted dishonestly in the matter."

The famous chemist, Sir Henry Roscoe, President of the British Association, pronounced saccharin 220 times sweeter than sugar. While we cannot say that that is going to displace the cultivation of the sugar cane, yet it is claimed that in medicine the product is invaluable. Saccharin does not assimilate and therefore can be used where sugar cannot be. The manufacture of it, which ought to have been begun here, and which rightly belonged here, is conducted in Germany. The Russian went to Germany, obtained a patent for the invention, is manufacturing the product there, and sending it back to this country. It sells at retail for \$2 per ounce. I also exhibit another product, antipyrine. Some of the best scientific authorities in the world say that this is a more powerful febrifuge than quinine. It has no bitter taste, and it works more quickly. It is now being made and sold largely. Another product, salol, is used in medicine in increasing volume as a remedy for rheumatism. But one of the latest and most interesting discoveries is thalleine, which has been used successfully in fevers, and is a curative of yellow fever. Oil of myrbane, having the odor of the oil of bitter almonds, is made in this country. I have here cumarin, identical with the extract obtained from distillation of the sweet-scented grasses, known in perfumery as "new mown hay." It is made from coal tar. Let me impress upon you that while we have not these industries now, they are coming; because the introduction of skilled talent in the gas industry and other manufactures will enable us, by and by, to establish here that enormous color industry, and other chemical industries, which are now held firmly in the grasp of Germany. Let me say a word on the subject of ammonia. That is increasing in use very largely, especially for artificial refrigeration. There are to-day in this country not less than 1,500 artificial ice-making machines. The number is increasing at the rate of 200 a year. Cities, towns, and even villages in the South, United States forts and naval vessels and ocean steamships are introducing that mode of producing ice and cooling, because it is cheaper and better, and gives a purer product, than ice obtained from the North River, or from any of the northern lakes. The residual from gas-making furnishes the cheapest and best source for obtaining the ammonia which is used, not only for this but for so many other purposes. There will be a steadily increasing value for that product. Therefore, there is certainly encouragement in knowing that in the near future the coal in the coal sheds will be paid for by the products obtained therefrom.

On motion of Mr. Clark, a vote of thanks was tendered to Mr. Nettleton for his interesting paper. The Convention then adjourned to reconvene on Thursday, October 20, 1887, at 10 A. M.

SECOND DAY—THURSDAY, OCT. 20—MORNING SESSION.

The Association met pursuant to adjournment.

PLACE OF NEXT MEETING.

Mr. Clark—The Committee appointed to select the place for holding the next meeting of the Association recommend Toronto, Canada. They originally desired to go South, to Atlanta, Nashville or Louisville, but as they received a very cordial invitation from Toronto they decided to accept it. I will read the letter of invitation:

"CONSUMERS GAS COMPANY, TORONTO, ONT., Oct. 15, 1887.

"C. J. R. HUMPHREYS, ESQ.,

"Secretary American Gas Light Association,
"Sturtevant House, New York.

"My Dear Sir: As it is possible that I shall not be able to attend the meeting of the Association until the afternoon of Wednesday, the 19th inst., and fearing that some decision may be arrived at before then, regarding the place of meeting next year, I write to say that our President, Vice-President and Directors have unanimously and cordially authorized me, on behalf of the Company, to extend to the Association a hearty invitation to hold their next meeting in the city of Toronto.

"We trust that as the Association has never met in Canada, and as we hope to have finished by that time a works that will not be unworthy of inspection, and as our city possesses many objects of interest, that this invitation will be favorably entertained.

"I assure you that we shall do our best to entertain the members of the Association, and to make their sojourn as pleasant as possible.

"As the weather here is somewhat colder toward the end of October than in the latitude of New York, I would suggest that, if practicable, the meeting take place in the first week of October, when it will be pleasanter weather for driving.

"Sincerely yours,

W. H. PEARSON."

The President—Does the Committee make any recommendation with regard to the time of holding the meeting?

Mr. Clark—The Committee recommend that the meeting be held, as Mr. Pearson suggests, in the first week of October.

The Secretary—The Constitution provides that the meeting shall

be held on the third Wednesday; and we cannot amend the Constitution except in regular form, or by unanimous consent. This has been done once before—at the time of the Chicago meeting—when it was found desirable, by reason of a political convention being held in Chicago, to have our meeting on the second Wednesday instead of the third.

The President—I think we may, by unanimous consent, agree to hold our meeting at the time suggested. The invitation which we have received from Toronto is certainly extremely cordial; and, if desired, I will put the question whether we will accept it, and at that date.

Mr. Boardman—Do I understand you are going to put the whole question, or simply the question as to the place of meeting?

The President—I will put it either way—separating the questions if you desire it.

Mr. Boardman—Then I wish you would divide the question, because there are very strenuous objections which might be advanced for not having the meeting quite so early.

The President—Then I will first put the question of the acceptance of the invitation to meet in Toronto, in accordance with the report of the Committee.

The invitation was unanimously accepted.

Mr. Huntington—I now move that the meeting at Toronto be on the regular date provided by the Constitution.

Mr. Boardman—I second that motion. As we meet for business considerations mainly, and want to have as many present as possible, we ought not to consider the weather, nor should we let any other consideration looking to our pleasure stand in the way. I think by meeting early in October a great many of us would be prevented from attending. Most of us have quarterly reports to make out in the first week in October, and, therefore, could not attend at that time.

The President—Does the Committee change their recommendation as to the time of meeting?

Mr. Clark—Yes; since it is a Constitutional matter. I did not remember that the Constitution said anything on the subject. As far as the convenience of our members is concerned, it seems to me that the early part of October would be more convenient than the latter part.

The President—It is obviously impossible to change it if objection is made.

Mr. Clark—Of course, if there is objection, that ends it.

The President—Then we will meet at the regular time in October in Toronto.

REPORT OF COMMITTEE ON PRESIDENT'S ADDRESS.

Mr. Taber—The Committee to whom was referred the President's Address make the following report with reference to the suggestion of the President as to the formation of a Committee of Investigation, so to speak. The idea of the Committee was to undertake it at this meeting, if possible, as a tentative plan, and to appoint a Committee which shall make a report upon its work, and advise next year as to a permanent organization. They make this report:

"A Committee should be appointed sufficiently large to have one member at least in each of the larger geographical divisions of our field of work. Each member should then be called upon for advice by those in his vicinity; and any question arising which he cannot decide, or is not willing to take the responsibility of so doing, can be submitted to the entire Committee, and they in turn, if desirable, can submit it to the entire Association. Let us start at once, and, by the time when we shall meet again, this Committee can report upon its work and advise as to its permanent organization. We would recommend that the President appoint a small Committee to select proper names for the members of this Investigating Committee—one each from Canada, the Eastern States, the Middle States, the Southern States, the Western States east of the Mississippi River, the Western States between that river and the mountains, and the Pacific slope. This Investigating Committee to serve one year, and be allowed to draw, through its Secretary, upon the treasury of this Association for its necessary expenses, not exceeding \$300, and report at the next meeting its work and a plan for permanent organization."

With reference also to the subject of badges which the President suggested, we recommend:

"That a committee of three be appointed by the President to invite designs for a permanent badge for the Association, to select from these designs the most suitable, ascertain its cost, and report to the next meeting."

They also recommend that a reprint of 800 copies of the President's Address be made and distributed among the members of the Association.

Mr. Clark—Do I understand that the Committee recommend the formation of a Committee by this Association to pass judgment upon all gas questions which may be submitted to them, for the benefit of local managers?

The President—Substantially that.

Mr. Clark—I am opposed to it, and for this reason: There are men in this country who make a living out of gas engineering by giving advice, and this plan, if adopted and carried out, would effectually put an end to that living. It would put it in the power of any gas manager to call upon the best talent in the business, and, without recompense, get from him, as a matter of right, the best advice that he can give; and not only call upon him, but also compel him to call upon others to assist him in giving advice. I think that will be a very bad principle to establish, and would effectually put a

stop to all individual efforts to make money out of gas engineering in this country.

Mr. Amory—I move the adoption of the plan recommended by the Committee. In making this motion, I have no desire to trench upon the question which Mr. Clark has raised. I doubt very much whether the investigation proposed, being a local affair, would interfere in the way he suggests. Of course, the Committee is appointed to investigate certain matters relating to the production of gas, and to report upon the plans which are known uncommercially. No gas manager would feel that he had a right to obtain, at very low cost, the advice of such Committee, and he would undoubtedly employ such experts as are known in the business. I think, therefore, that the fear which Mr. Clark expresses would not be realized. I certainly hope that this Association will take some such course as is suggested. We, who are business men, and connected with gas works, would very much like to take some such concert of action. If there is any scientific investigation of value in the production of gas, or which will cheapen or improve the production, I think that the expert will come in for his share in the investigation and will receive his proper fee.

The President—I would remind Mr. Clark of the fact that this is a proposition upon my part to do what there seems to be a large demand for among gas companies. I understand that Mr. Egner received something like 100 letters from gas companies, agreeing to pay something toward the expense of a scheme such as he proposed. It seems to me this could be done and, without subjecting those gas companies to that expense, produce the same desirable results. Concert of action by the gas companies seems to be demanded. This is an attempt to do what he proposes, but to do it somewhat better, and also to benefit the whole profession by giving us at our meetings the results of the investigations, whatever they may amount to. I may say I agree with Dr. Amory, for I do not think the business of the expert is going to be done away with in this country, even if there is sufficient business to be done in that direction to keep an investigating committee busy.

Mr. King—As a member of the Committee appointed by the Western Association to consider Mr. Egner's paper, I may say that, in fact, I know very little about it, because Mr. Egner has taken the matter altogether into his own hands. I have seen him since, but for a few moments. Just before leaving home, he sent me some facts to be presented to the Association. I did not hear the first part of this discussion, but if pertinent, and if it would be interesting to hear them, I will present a few of those facts for your consideration.

The President—Mr. Taber, as chairman of the Committee, recommends the appointment of such a Committee as I suggested in my address.

Mr. King—Personally, I think your suggestion is preferable in every way to the plan proposed by Mr. Egner. I will read a few of his figures. [Mr. King here gave some facts in connection with the work that had so far been accomplished by Mr. Egner in the matter of the proposed Institute.]

Mr. Clark—I wish to call attention to the difference between the Egner plan and the plan suggested by this report. Mr. Egner proposes the employment of an engineer, and the use of an experimental station. He proposes to try, practically, all the patents that are issued for the manufacture of gas. In this report the Committee propose the appointment of a Committee who shall give their advice as to the practicability of plans, but shall do so without trying them. There is a decided difference in the two methods. Mr. Egner would have an actual trial of a plan, but this Committee would simply give advice with reference to it. As I have said, men are making their living by giving such advice, and it seems to me a pity to take that method of making a living out of their hands. It places before every gas manager the temptation to obtain, at very little trouble and expense, whatever information he may desire to secure with regard to the conduct of his gas works.

Mr. Zimmerman—If I understand this system, it seems to me to be a good thing for the gas companies, but rather a hard thing upon this Association. If the Association has to stand the expense of these investigations the gas companies would be receiving all this information for nothing simply because the Association would be paying the expense of obtaining it. As there are a good many patents and improvements constantly brought to our attention, this Association would get a great deal of valueless, as well as a good deal of valuable, information; but that valuable information would cost them a high figure. Traveling expenses and the like would precede and follow the investigation of a valueless as well as a valuable patent. It seems to me the gas companies ought to pay the expenses of the Investigating Committee.

Mr. Harbison—I do not agree with the last speaker. Gas companies, as is well known to consumers, have become, practically, benevolent institutions. Why, therefore, should we depart, in this instance, from our benevolent custom, and detract from our reputation? If, as an Association, we lend a helping hand to those who do not know as much as the representatives of the larger companies, we are simply carrying out the principle already established. I do not think it will be wise or fair to ask a poor, weak company (like the one that I represent) to pay the traveling expenses of members of a Committee, coming from all over the country, to investigate a matter for such a company. This Association has a large fund in the treasury, and they cannot do better with it than to help me. Then I will be willing to help my neighbor, over the line in Rhode Island, or somewhere else. I hope that the report of the Committee will be adopted, and that we shall try the experiment

suggested by them. Let us put up an experimental station, if it is desirable—I think it would be a good thing. Then the Committee will be able to give us information, from year to year, that will be of value to the oldest and to the wisest men who are here. It will be the concentration of the wisdom of this Association, simmered down into a report which will be of great value to us, and then let us have it put on record. I think one speaker is in error in saying that the Committee would not practically test the value of any improvement that might be brought to their attention. I do not see how they could make an examination of it and make a report to this Association, unless they had made such a test at some spot which might be decided upon. I think they would be quite as competent to do it as the average expert—the Committee would be made up of seven experts, and they would be supposed to possess the combined wisdom of the whole country. I misapprehend the performance of the Committee very much, if they did not carry a suction pump with them whenever they went to a noted expert, in order to take information from him without his knowing it, and so be able, upon that information, to make a report which would be of benefit to the profession. I hope the report will be adopted, and that the plan suggested will be thoroughly tested.

Mr. A. C. Humphreys—I am disposed to think, after some consideration, that the plan of Mr. Egner is quite impracticable; and it also seems to me that the method now suggested is rather cumbersome, although there are certainly some excellent ideas in it; but why would not the whole subject be covered by the more efficient organization of this Association? We, as the representatives of a great many companies, meet from year to year, and are doing more or less all the time in the way of investigation. If we could so organize and arrange that work as to have individual members devote time enough, year after year, to thoroughly digest the results of investigations made by the members of the Association, I think it would afford a much better prospect of advantage than the method suggested. For myself, I can safely say that I would have no time to serve on such a Committee; and I do not see how any busy gas man could. He would be called upon to investigate in respect to subjects that did not interest him at that particular moment; consequently he would not work so thoroughly, nor produce results as valuable as he otherwise would. We all know that a man is better able to do effective work on any line of thought if he is forced to it by some necessity or consideration at that particular moment. Such is human nature. But by this plan you may be called upon to make an investigation into something which, up to that moment, has been entirely thrown out of sight by reason of other considerations. I think the whole subject resolves itself just into this—if we determine to make this Association more efficient in investigating these subjects, and in keeping track of what our members are doing, there will be no necessity for anything of this kind. I recognize the value of one argument, and a strong one, which can be brought against that plan—it does not give a member the opportunity of finding out anything until the next meeting; but I do not think that there are any of us who would not feel entirely at liberty to call upon any member of the Association whom we thought particularly qualified to give an opinion upon any particular subject.

Mr. Boardman—In support of the recommendation of the Committee, let me say I think we are striving, by this very means, to reach what Mr. Humphreys has suggested as being so desirable—we are attempting to organize our experience. Individually, we are all making experiments, and individually we are all willing to give our experience to our brother members. This Committee will simply be organizing this experience, and bringing it properly before the Association in a digested form, and in which it can be better assimilated by the individual members. I would ask, if any subject comes up which this Association wishes to decide upon, does it not appoint a Committee to investigate it? Is this Committee composed only of men who are at the moment engaged in considering that particular subject? I think that that Investigating Committee would be capable of taking up any question which might be brought to them; and if they were not they would be possessed of information as to who they should call upon as a volunteer to supply what they lack. Would it not be cheaper, for the gas business at large, to have such an Investigating Committee, which would lay these facts before their representatives, many of whom have their expenses paid in coming to these meetings? We are here in the interest of our companies, and these companies pay our expenses, hence we want to get value received for them. I think this plan is a good one. I do not think it would be wise for us to wait until we can get up a perfect organization before trying any. I trust that the recommendation will be acted upon so that we may do something at once.

Mr. Amory—It seems to me that the argument and discussion brought out by this report of the Committee, and by the motion now before the meeting, is a little out of the course. As I understand the report of the Committee, it is not intended that this Committee shall be a committee of experts, for, if it were a committee of experts, the suggestion to pay them only sufficient to cover their traveling expenses would be ridiculous. As I understand the report of the Committee, it is a Committee to be appointed by the Association to act as a medium of exchange between those who have methods of making gas which are claimed to be improvements upon the methods now in use, and those who are engaged in the business. This Association is particularly interested in the interchange of opinions between members in different parts of the country. Of course, no Committee could act successfully if one member lived in San Francisco, another in New York, and another in New

Orleans. The point made in the President's address is certainly covered by the recommendation of the Committee, and in the motion before the Association. I believe that we all feel a sufficient interest in the subject of making gas to prompt us to lay before such a Society of Gas Engineers all the improvements which may be made in various parts of the country. As an individual member of this Association, and representing a company of small means, I think this method of getting at the question is one which is favorable to the gas companies, and as favorable to the experts who are interested in promulgating new ideas; and that it will reach the point much better than any other which has yet been suggested or tried. I sincerely hope that this tentative plan, for one year, will receive the approval of this Association. [The recommendation of the Committee was approved.]

The President—I await a motion as to the appointment of such a Committee. It seems to me the best way to secure an effective Committee is to recommit this matter to same committee with a request to report this afternoon the names of an Investigating Committee who shall enter upon this investigation. [Mr. Amory made a motion in conformity with the suggestion of the President's. Motion adopted.]

ELECTION OF OFFICERS.

Mr. Sherman—The Committee appointed to nominate officers for the ensuing year recommend that the following-named gentlemen be elected:

President—Thomas Turner, Charleston, S. C.
Vice-Presidents—A. B. Slater, Providence, R. I.; Emerson McMillin, Columbus, O.; J. P. Harbison, Hartford, Conn.
Secretary and Treasurer—C. J. R. Humphreys, Lawrence, Mass.
Finance Committee—C. H. Nettleton, Birmingham, Conn.; A. E. Boardman, Macon, Ga.; W. H. Pearson, Toronto, Ont.
Executive Committee—William Henry White, New York city; G. G. Ramsdell, Vincennes, Ind.; H. B. Leach, Taunton, Mass.; D. H. Geggie, Quebec, Canada.; T. G. Lansden, Washington, D. C.; F. S. Benson, Brooklyn, N. Y.

On motion of Mr. Amory, the Secretary cast the ballot of the Association for the list of officers recommended by the Committee, whereupon the President announced that they were duly elected officers for the ensuing year.

Mr. Harbison and Mr. Clark were appointed a Committee to conduct the President-elect to the platform.

The President—Allow me to present to the Association, Mr. Thomas Turner, the incoming president.

Mr. Turner—Gentlemen of the Association: I suppose that our worthy President expected a few remarks from me; but I have no remarks to make this morning, except to thank you, most heartily, for the honor you have done me, in electing me to the Presidency of this Association. (Applause.)

[To be continued.]

End of the Baltimore Gas War.

The Baltimore *Sun* of October 27, in explanation of the peace treaty now under consideration by the gas companies of that city, says:

The gas companies of Baltimore have settled their differences, and on November 1 the price of gas to consumers will be advanced to \$1.50 per 1,000 feet, net. The executive committees of the Consolidated and Chesapeake companies were in joint session until late yesterday afternoon, and when they adjourned it was announced that the basis for a settlement had been agreed upon, and that the three existing companies, the Consolidated, Chesapeake and Equitable, will on January 1, 1888, be merged into one concern. The board of directors will meet to-day to ratify the agreement.

Capt. John W. Hall, president of the Consolidated, said: "The differences between the gas companies have been settled, and the price of gas will, on November 1, be advanced to \$1.50 net, or \$1.60 gross, the price at which it was sold up to the time the Chesapeake went into business, eighteen months ago. The people of Baltimore have had the benefit of cheap gas at a loss to the companies of \$2,000,000, and we do not think the advance to \$1.50 is more than a fair price, especially for the fine quality of gas which is being furnished to Baltimore consumers. It is worth that price, which will give only a reasonable profit to the producers. The boards may modify the terms of consolidation, but the agreement is practically settled. The stockholders will be called together in thirty days to ratify the agreement, and by January 1 the books will be in shape for the operations of the amalgamated company. The consolidation will be made for economical reasons, and will permit of a desirable reduction in operating expenses."

The reported basis of the merger of the three companies is for the \$6,000,000 Consolidated stock to go into the new stock at par, the Chesapeake stock and certificates at one and a-half for one share of the new stock, and the Equitable at four shares for one share of new stock. A well-informed banker said he figured it out that the new amalgamated gas company will have from \$10,000,000 to \$11,000,000 of capital stock and \$5,000,000 or \$6,000,000 of bonded debt.

Complaints.

The *Gas World* having previously reviewed some of those complaints that emanate from sources over which the suppliers of gas have at least partial control, in a later issue refers (and pretty cleverly, too) to some which arise from circumstances clearly within the control of the gas user. Our authority goes on to say:

According to the decision given by Mr. Justice Kekewich in the recent lawsuit between the Gas Light and Coke Company and the South Metropolitan Gas Company, it is the common law of the land that gas-supply authorities' responsibilities and control terminate at the meter. From there, as laid down by his Lordship, the consumer can take the gas to any of his property, whether near or far, and use it as he pleases. Whether this decision, which is to be appealed against, will be sustained by the higher courts remains to be seen; but until it is upset, or altered by act of Parliament, it must be considered the law. We know that at Dumbarton, and perhaps in a few other towns, the gas-supply authorities make regulations as to the size of the supply pipes on the consumer's premises, and refuse to supply gas in any instances where those regulations are not complied with. These, however, are rare and singular exceptions to the rule that, after the gas has left the meter, it is absolutely under the control of the consumer. Many gas managers, notably amongst whom may be mentioned Mr. John M'Crae, of Dundee, are desirous that the gasmaker's authority should be extended beyond the meter. Indeed, the gentleman just named expressed the opinion, at the North British Association at Dundee, that the maker's control ought not to cease until the gas appeared in the form of light. There is much to be said for and against these views. But at the present time we do not intend to enter upon this debatable ground beyond expressing the opinion that we think gas-supply authorities ought to have the power to fix the minimum sizes of supply pipes that shall be laid in new buildings, and also to enforce the use of larger supply pipes in existing buildings when complaints about insufficiency of gas are found to be owing to the consumer's pipes being too small. Such an extension of authority appears to us to be reasonable in itself; and that in tens of thousands of instances it would tend greatly to the comfort, convenience, and health of consumers will not be questioned by anyone practically acquainted with the subject.

As a rule, except in the case of cottages, the gas supply in dwelling houses is inadequate for the requirements of the household during winter evenings. The want of supply has originated in ignorance, prejudice, or greed. Few gasfitters, notwithstanding their practical experience, know what sizes of pipes will convey an adequate supply of gas at a suitable pressure for a given number of burners distributed over a building. Their golden rule seems to be to diminish as they get further and further away from the meter. Now, a gas-supply authority would be able either to find or to educate a fitter who would be competent to go into such matters with some approximation to satisfactoriness. Then the prejudice existing in past years is often accountable for insufficient gas supply. Formerly large numbers of people would only allow gas to enter their kitchens and out-buildings, and small pipes were consequently laid down. Gradually they extended the use of gas to the living and sleeping rooms, but got the supply from the old small pipes, which prove insufficient to convey the increased demand. Such is the history of thousands of houses having an insufficient supply of gas. The extensions of premises, without provision for obtaining more gas, bring about similar results. But the jerry-builder has more to answer for in causing short gas supply than anyone else. In his avarice he deliberately cuts down anything whereby he can gain sixpence, and the gas pipes are amongst the first objects to catch his greedy eye. They are reduced, often to the smallest sizes made, regardless of every consideration except gain. The miserable work is afterward covered by the plasterer, and the luckless purchaser or tenant is cursed with wretched gas lights so long as he occupies the house.

Now, from whatever cause it arises, want of gas supply gives rise to numerous complaints, such as dimness of light, unsteadiness of flames, and smoke. When these are made, we think that, having first ascertained that there is a sufficient supply at the meter inlet, some official should examine the consumer's pipes and fittings, and if they are too small, or badly fitted and arranged, advise some definite alterations. It is of little use telling a consumer in an airy manner that he ought to have larger pipes, and have them laid in a proper manner. Such advice is too vague to be followed, and often by its very generality induces the suspicion in the consumer's mind that his adviser knows very little about his business. All this work, we know, will entail labor, and often expense. But neither should be begrudged when there is a call for them. Besides, in most instances, it will well repay the gas supplier

both in comfort and in pocket. People whose premises are thoroughly well lighted, whether those premises be the home, the shop, or the mill, rarely grumble about the gas or their bills. The great grumblers are those who get poor results for their money, whatever may be the cause of the defect. Then, of course, when larger services are introduced and more gas is consumed, the suppliers have increased revenues and enhanced profits. These considerations alone ought to be sufficient to prompt gas authorities to take pains to secure that consumers' supply pipes are equal to their requirements.

Now we come to the old sources of dissatisfaction, bad burners. Attention has been so often directed to these that even to allude to them seems like reciting a threadbare tale. But the evils still exist, and therefore they must be hammered at. Burners may be bad to begin with, or they may become bad by use. In either case they want removing. There is no reason why anyone should continue to use a bad burner. Excellent burners are everywhere obtainable, for a copper or two each, and where bad burners are still employed the gas officials ought to advise consumers to buy good ones. Some gas authorities have given good burners to their consumers free of charge, and have also fitted them on to insure their use. The cost is comparatively trifling, but the improvement is immense. In Paisley Mr. Hislop induced the Corporation to make a trial of that plan, and he supplied consumers with burners suited to the prevailing pressures in the various districts of the town. The experiment was a great success, but, unfortunately as we think, the authorities have decided not to continue it. But however good burners are when new, they will not remain so forever. Burners, besides being occasionally cleaned, ought to be changed once a year, and now is the time of the year when the change may be effected with most advantage. As just indicated, the cost is small, and would be repaid in a few hours by the additional light and comfort that would be obtained.

In spite of all that has been written and said, chandelier makers will flood the market with chandeliers fitted to take globes with narrow bottoms, and gasfitters will continue to inflict upon customers such chandeliers and globes to suit them. We say it advisedly that the multiplication of such abominations is a disgrace to the trades concerned therewith. Nothing tends more to make the flames unsteady as globes with narrow openings at the bottom, besides which such a formation obstructs the downward passage of the light. These evils are so great that it ought to be a standing instruction to gas officials to war against the appliances that produce them. Attention ought also to be given to the material of which the globes are made. Opal globes, from a light yielding point of view, are miserable. Globes made of ground glass, figured or plain, are the best for general purposes, and their use should be recommended.

Again, when governor burners are employed, they, too, ought to be of a form and size that will interfere as little as possible with the free, downward passage of the light. Governors in the form of a big bulb, however much they may be decorated, do more harm by obstructing the light than they do good by regulating the flow of gas. The attention of consumers may be profitably directed to these facts. How often we see a costly, cumbrous chandelier, with opal globes having narrow holes at the bottom, or, if the holes be wide, blocked with a big governor, all of which arrangements smother the light and fill the room with gloom. Against such arrangements war should be ceaselessly waged.

Gasfittings ought to be simple and easily understood, and require as little attention as possible. Daily experience shows that the majority of people will not bestow the attention necessary to keep the simplest appliances in good order. Hence gas officials will do well not to hastily recommend complicated or delicate apparatus, however splendid its laboratory results, or however efficient it may be in the hands of an expert.

The Market for Gas Securities.

The city gas share market responded quickly to the improvement in the tone of general speculation, Consolidated moving up to 74 on small transactions. Equitable and Mutual shares also shared in the rise, the advance in the former security being quite marked. Brooklyn shares are seemingly looked at unfavorably by investors, and we think all of these stocks are quoted considerably below their real value. The old Brooklyn Company has declared a semi-annual dividend of 3½ per cent., payable on the 10th inst. While this is a reduction from the rate formerly declared, it must be borne in mind that it is the first return made since the \$1.60 legislative gas rate began to affect the Company's earnings. The Baltimore war of rates may be considered a thing of the past, and its settlement has added greatly to the value of gas shares in that city. Those who followed our advice in this instance have no reason to complain of the result. Old Boston shares are lower.



A. M. CALLENDER & CO.,
PROPRIETORS.

Editor—**JOS. R. THOMAS, C.E.**
Asst. Editor—**T. J. CUNNINGHAM.**
Manager—**C. E. SANDERSON.**

PUBLISHED ON THE 2ND AND 16TH OF EACH MONTH
At No. 42 Pine Street, New York.

This is a recognized official organ of—
LIGHT, HEAT, STEAM, WATER-SUPPLY,
VENTILATION, SANITARY IMPROVEMENT
AND GENERAL SCIENCE.

TERMS

SUBSCRIPTION—Three Dollars per annum, in advance.

AGENTS

NEW YORK—AMERICAN NEWS CO. 39 and 41 Chambers St.
BOSTON—S. M. PETTENGILL & Co., 6 State Street.
PHILADELPHIA—PRATT & Co., Corner 9th and Arch Streets.
England—C. W. HASTINGS, 22 Buckingham St., London, W.C.
Germany—B. WESTERMANN & Co., of New York

WEDNESDAY, NOVEMBER 2, 1887.

Gas Stocks.

Quotations by Geo. W. Close, Broker and Dealer in Gas Stocks.

16 WALL ST., NEW YORK CITY.
NOVEMBER 2.

All communications will receive particular attention.

The following quotations are based on the par value of \$100 per share.

	Capital.	Par.	Bid	Asked
Consolidated.....	\$35,430,000	100	73½	74
Central.....	440,000	50	30	—
“ Scrip.....	220,000	—	47	57
Equitable.....	2,000,000	100	115	—
“ Bonds.....	1,000,000	—	113	115
Harlem, Bonds.....	170,000	—	—	—
Metropolitan, Bonds....	658,000	—	110	113
Mutual.....	3,500,000	100	90	92
“ Bonds.....	1,500,000	1000	101	—
Municipal, Bonds.....	750,000	—	—	—
Northern.....	125,000	50	30	—
“ Scrip.....	108,000	—	—	—
Yonkers.....	—	50	—	80
Richmond Co., S. I.....	300,000	50	50	—
“ Bonds.....	12,000	—	—	—
Gas Co's of Brooklyn.				
Brooklyn.....	2,000,000	25	100	105
Citizens.....	1,200,000	20	50	—
“ S. F. Bonds....	320,000	1000	—	103
Fulton Municipal.....	3,000,000	100	128	—
“ Bonds....	300,000	—	—	106
Peoples.....	1,000,000	10	57	60
“ Bonds (5's).....	368,000	—	97	—
“ “ (6's).....	94,000	—	100	—
Metropolitan.....	1,000,000	100	77	80
Nassau.....	1,000,000	25	90	95
“ Cfts.....	700,000	1000	95	100
Williamsburgh.....	1,000,000	50	100	—
“ Bonds... ..	1,000,000	—	111	—
Out of Town Gas Companies.				
Boston (Mass.) Gas Co.	2,500,000	500	220	—
Buffalo Mutual, N. Y....	750,000	100	90	95
“ Bonds... ..	200,000	1000	95	100
Citizens, Newark.....	1,000,000	50	140	145
“ “ Bonds.	45,000	—	—	—
Chicago Gas Trust.....	25,000,000	100	40	41

Cincinnati G. & C. Co..	6,000,000	100	182½	185
Consolidated, Balt.....	6,000,000	100	70	73
“ Bonds....	3,600,000	—	107	107½
Chesapeake, Balt.....	1,000,000	100	90	95
“	1,000,000	—	100	102
Consumers Toronto....	1,000,000	50	192	—
Central, S. F., Cal.....	—	—	—	84
Capital, Sacramento, Cal.	—	—	57½	60
Hartford, Conn.....	750,000	25	140	142
Jersey City.....	750,000	20	168	—
Laclede, St. Louis, Mo.	2,000,000	100	125	—
Louisville, Ky.....	2,570,000	50	130	132
Little Falls, N. Y.....	50,000	100	95	100
“ Bonds	25,000	—	100	103
Montreal, Canada.....	2,000,000	100	220	221
Memphis (Tenn.) Gas... ..	750,000	100	—	—
“ Bonds.	240,000	100	103	—
New Haven, Conn.....	—	25	193	197
Oakland, Cal.....	—	—	—	36½
Peoples, Jersey City. . .	—	—	60	—
“ “ Bonds..	—	—	—	—
Paterson, N. J.....	—	25	90	—
Rochester, N. Y.....	—	50	75	80
Syracuse, N. Y.....	350,000	25	—	—
St. Louis, Missouri.....	600,000	50	—	—
San Francisco Gas Co.				
San Francisco, Cal....	10,000,000	100	58	59
Washington, D. C.....	2,000,000	20	210	—
Wilmington, Del.....	—	50	200	208
Havana (Cuba) Gas Co.	3,000,000	100	18	20
“ Bonds.....	550,000	—	102	—

Advertisers Index.

	Page
GAS ENGINEERS.	
Jos. R. Thomas, New York City	296
Wm. Henry White, New York City	296
Wm. Mooney, New York City.....	296
William Gardner, Pittsburgh, Pa	296
GAS WORKS APPARATUS AND CONSTRUCTION.	
James R. Floyd, New York City	299
T. F. Rowland, Greenpoint, L. I.....	299
Deily & Fowler, Phila., Pa.....	299
Kerr Murray Mfg. Co., Fort Wayne, Ind.....	298
Stacey Mfg. Co., Cincinnati, Ohio.....	299
Bartlett, Hayward & Co., Baltimore, Md.....	289
Morris, Tasker & Co., Limited, Phila., Pa.....	298
Davis & Farnum Mfg Co., Waltham, Mass	288
R. D. Wood & Co., Phila., Pa.....	298
Bouton Foundry Co., Chicago, Ills	299
Smith & Sayre Manufacturing Co., New York City.....	299
PROCESSES.	
National Gas Light and Fuel Co., Chicago, Ills.	290
American Gas Improvement Co., Pittsburgh, Pa	287
GAS AND WATER PIPES.	
Gloucester Iron Works, Phila., Pa.....	296
Mellert Foundry and Machine Co., Reading, Pa. (John Fox, Selling Agent, N. Y.).....	296
Cincinnati and Newport Iron and Pipe Co., Newport, Ky... ..	296
Ohio Pipe Co., Columbus, Ohio.....	296
Pancoast & Rogers, New York City.....	296
M. J. Drummond, New York City	296
Wells Rustless Iron Co., New York City.....	296
R. D. Wood & Co., Phila., Pa.....	298
GAS ENGINES.	
Schleicher, Schumm & Co. Phila., Pa	256
Clerk Gas Engine Co., Phila., Pa	291
RETORTS AND FIRE BRICK.	
J. H. Gautier & Co., Jersey City, N. J.....	294
B. Kreischer & Sons, New York City.....	294
Adam Weher, New York City.....	294
Laclede Fire Brick Works, St. Louis, Mo.....	294
Brooklyn Retort and Fire Brick Works, Brooklyn, N. Y.	294
Borgner & O'Brien, Phila., Pa	294
James Gardner, Jr., Pittsburgh, Pa.	294
Henry Maurer & Son, New York City.....	291
Chicago Retort and Fire Brick Works, Chicago, Ills.....	294
Baltimore Retort and Fire Brick Co., Baltimore.....	294
Oakhill Gas Retort and Fire Brick Co., St. Louis, Mo.....	294
Evens & Howard, St. Louis, Mo.....	295
Cincinnati Gas Retort and Fire Brick Works, Cincinnati, O.	295
Emil Lenz, New York City.....	295
SCRUBBERS AND CONDENSERS.	
G. Shepard Page, New York City.....	297
R. D. Wood & Co., Phila., Pa.....	298
REGENERATIVE FURNACES.	
Bartlett, Hayward & Co., Baltimore, Md.....	289
Fred. Bredel, New York City.....	295
GAS GOVERNORS.	
T. C. Hopper, Phila., Pa	292
Connelly & Co., New York City.....	291
CEMENTS.	
C. L. Gerould & Co., Brooklyn, N. Y.....	294
GAS ENRICHERS.	
Standard Oil Co., Cleveland, Ohio.....	300
GAS METERS.	
Harris, Griffin & Co., Phila., Pa.....	302
American Meter Co., New York and Philadelphia	303
The Goodwin Gas Stove and Meter Co., Philadelphia, Pa... ..	303
Helme & McIlhenny, Phila., Pa.....	303
D. McDonald & Co. Albany, N. Y.....	303
Nathaniel Tufts, Boston, Mass.....	302
Maryland Meter and Manufacturing Co., Baltimore, Md.	287
EXHAUSTERS.	
P. H. & F. M. Roots, Connersville, Ind.....	290
Smith & Sayre Manufacturing Co., New York City... ..	299
Wilbraham Bros., Philadelphia, Pa.....	291
Counelly & Co., New York City.....	291
GAS COALS.	
Penn Gas Coal Co., Phila., Pa.....	301
Perkins & Co., New York City	300
Newburgh Orrel Coal Co., Baltimore Md	301
Despard Coal Co., Baltimore, Md.	301
Chesapeake and Ohio R.R. Coal Agency, N. Y. City.....	301
Westmoreland Coal Company, Phila., Pa.....	301
Monongahela & Peters Creek Gas Coal Co., Pittsburgh, Pa..	301
CANNEL COALS.	
Perkins & Co., New York City.....	300
J. & W. Wood, New York City.....	300
VALVES.	
Ludlow Valve Manufacturing Co., Troy, N. Y	292
John McLean, New York City	292
Chapman Valve Manufacturing Co., Boston, Mass.....	292
R. D. Wood & Co., Phila., Pa.....	298
The Combination Gas Machine Co., Detroit, Mich.....	287
ENGINES AND BOILERS.	
Jarvis Engineering Co., Boston, Mass.....	291
PURIFYING MATERIAL.	
S. H. Douglas, Ann Arbor, Mich.....	295
Connelly & Co., New York City.....	291
GAS LAMPS.	
The Siemens-Lungren Co., Philadelphia, Pa.	297
G. Shepard Page, New York City	292
Albo-Carbon Light Co., Newark, N. J.....	287
Standard Gas Lamp Co., Phila., Pa.....	295
PURIFIER SCREENS.	
John Cabot, New York City... ..	239
Geo. A. Mills, Baltimore, Md.....	292
GAS STOVES.	
American Meter Co., New York and Philadelphia... ..	293
The Goodwin Gas Stove and Meter Co., Phila. Pa.	304
The Combination Gas Machine Co., Detroit, Mich.....	287
Dinsmore Manufacturing Co., Boston, Mass	287
STREET LAMPS.	
J. G. Miner, Morrisania, New York City.....	239
Bartlett Street Lamp Mfg Co., New York City.....	295
BURNERS.	
C. A. Gefroter, Phila., Pa.....	300
STEAM BLOWER FOR BURNING BREESE.	
H. E. Parson, New York City.....	244
GASHOLDER TANKS.	
W. C. Whyte, New York City.....	298
GAS FIXTURES.	
Mitchell, Vance & Co., New York City... ..	292
COKE CRUSHER.	
C. M. Keller, Columbus, Ind.....	301
ELECTRICAL APPARATUS.	
Waterhouse Electric & Manufg Co., Hartford, Conn.....	288

FOR SALE.

ONE-QUARTER OR ONE-HALF INTEREST IN A FIRST-CLASS GAS & ELECTRIC LIGHT PLANT,

in one of the most prosperous cities of Texas. To include the control of its management, and friendship and goodwill of its present owners, who do not wish to sell out entirely. Address 681-2 J. W., care this Journal.

POSITION WANTED

As Superintendent of Gas Works

By a man having 12 years' experience in the manufacture and distribution of coal and water gas. Is familiar with construction of works. Also, has some knowledge of electric lighting. Address "W. P. L.," care this Office.

Position Wanted,

By a young man (22)

As Superintendent of a Gas Works.

Understands thoroughly the manufacture and distribution of coal and water gas, and is also a graduate chemist of the School of Mines, N. Y. Address R. E. SLADE, Yonkers, N. Y.

ENGLISH

"Journal of Gas Lighting."

Issued weekly. New volume commences Jan. 1, 1887. Price, \$7 per annum. Subscriptions taken by **CHARLES NETTLETON, Agent for U. S.,** No. 115 BROADWAY, N. Y. CITY.

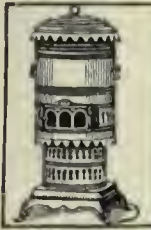

CONE GAS STOVE

FOR HEATING rooms of any size. Perfect combustion. No injurious odors to be carried away by a chimney. Warranted odorless, or the purchase money refunded. **DINSMORE MFG. CO.,** 28 Kneeland Street, Boston, Mass. Send for Catalogue.

GAS STOVES

Of Every Description, for Heating, Cooking, Laboratory, and Mechanical Purposes.

Weber Straight-Way Valves

FOR GAS, STEAM, AND WATER.

Catalogues on Application.

Correspondence Solicited.

THE COMBINATION GAS MACHINE CO.,
Detroit, Mich. Windsor, Ont.

163 Maiden Lane, N. Y. City.

87 Dearborn Street, Chicago, Ill.

CHARLES E. DICKEY.

JAMES B. SMALLWOOD.

CHARLES H. DICKEY.

Maryland Meter and Manufacturing Co.,

307 and 309 Saratoga Street, Baltimore, Md.

195 and 197 Michigan Street, Chicago, Ill.

1115 Olive Street, St. Louis, Mo.

MANUFACTURERS OF

DRY GAS METERS, STATION METERS, GLAZED METERS, TEST METERS, METER PROVERS, PRESSURE & VACUUM REGISTERS,

Governors, Indicators, Service and Meter Cocks, and Meter Connections.

"SUCCESS" GAS RANGES.

Meter Repairing a Specialty.

illuminating Gas from Natural Gas.

THE AMERICAN GAS IMPROVEMENT CO., Limited, 95 Fifth Avenue, Pittsburgh, Pa.

Erect Apparatus for the treatment of Natural Gas for an Illuminant under the

McKAY-CRITCHLOW SYSTEM.

Satisfaction in Economy and Quality Guaranteed.

Apparatus adapted to the manufacture of Water Gas, without any change whatever, should it be desirable to do so on account of Natural Gas playing out. Apparatus erected or Licenses sold at the following Works.

Pittsburgh Gas Works, J. H. McElroy, Engr.
Allegheny Gas Works, Robt. Young, Engr.
East End Gas Works, W. H. Denniston, Engr.
West Pittsburgh Gas Works, E. C. Critchlow, Supt.
Beaver Falls Gas Works, H. F. Dillon, Supt.
Titusville Gas Works, E. T. Roberts, Treas.
Salamanca, N. Y.
Jamestown, N. Y.
Meadville, Pa., Wm. Reynolds, Prest.

Warren, Pa., S. S. Franklin, Supt.
Franklin, Pa., C. W. Gilfillan, Prest.
Oil City, Pa.
Erie Gas Co., Erie, Pa., W. H. Hill, Engr.
Greensburg, Pa., Jas. C. Clarke, Prest.
Sewickley, Pa., J. W. Forbes, Supt.
Bellaire, Ohio, John Ferguson, Supt.
New Castle, Pa., D. T. Flick, Supt.
Corry, Pa.

Sharon, Pa., S. Perkins, Prest.
Fort Scott, Kansas, L. K. Scofield, Owner.
Fostoria, Ohio, Jos. Gwynn, Supt.
Emporia, Kansas.
Tiffin, Ohio.
Wellsville, Ohio.
Brownsville, Pa.



THE ALBO-CARBON LIGHT.

THIS SYSTEM HAS SHOWN ITSELF IN THOUSANDS OF CASES—IN HALLS, CHURCHES, PICTURE GALLERIES, CONCERT HALLS, RESTAURANTS, BANKS, CLUBS, STORES, OFFICES, and PRIVATE RESIDENCES—TO BE THE

Best Adapted and Most Successful Method of Gas Lighting Ever Offered.

The **SOFTNESS AND PURITY OF THE LIGHT** make it most desirable for Office and Household Uses. Its **BRILLIANCY** and **POWER** render it unrivaled for lighting Halls, Churches, etc. Its **ECONOMY** secures for it general favor wherever used.

NOTICE.—Suits are pending in the United States Circuit Courts in Illinois and Pennsylvania against various parties for infringement of our Letters Patent No. 247,925, dated October 4, 1881, and No. 333,862, dated January 5, 1886. The first of these suits has come up for hearing, and an injunction has been granted therein. The second of said suits has not yet been reached for hearing. All persons are cautioned against manufacturing, selling, or using any apparatus or material which infringes our patents. We intend to prosecute all parties infringing patents owned by us.

ALBO-CARBON LIGHT CO. (Sole Manufacturers for the United States) Main Office, Newark, N. J.

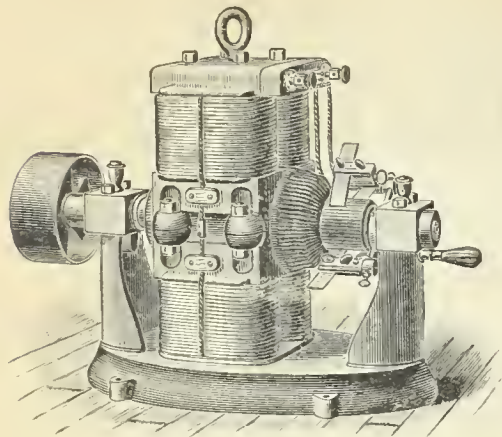

Great Improvements! WATERHOUSE SYSTEM ADVANCING!

We are running

120 2000-C.P. Lights on an 80-H.P. Engine

at its most economical point of cut-off. We guarantee our 2000-C.P. light

Will Successfully Compete with any Arc Light in the World for Size, Color & Steadiness.

THE ONLY SYSTEM WITH AN INSTANTANEOUS AUTOMATIC REGULATOR.

THE WATERHOUSE ELECTRIC AND MFG. COMPANY,
Factory, Colt's West Armory. **Hartford, Conn.**

To All Whom It May Concern!

The SIEMENS-LUNGREN COMPANY hereby warns the public against the use of various infringing Regenerative Gas Lamps which are offered for sale. This Company has heretofore delayed bringing suit to enjoin the manufacture or importation of such infringing lamps, solely because of the practical worthlessness of the infringing devices; and although, in each instance, they infringe some one or more of the various patents owned or controlled by this Company, they have fallen into disuse sooner than any suit could be brought to a hearing. As, however, the introduction of these infringing lamps has tended to discredit the practicability of our Company's system of regenerative gas lighting, we have instructed our Attorneys, Messrs. Geo. Harding, C. S. Whitman, and Silas W. Pettit, to give notice that legal proceedings will in future be taken against all such infringers.

THE SIEMENS-LUNGREN CO., 21st St. & Washington Av., Phila., Pa.

F. J. DAVIS & J. R. FARNUM,

TRUSTEES AND AGENTS FOR THE

SINUOUS FRICTION CONDENSER.

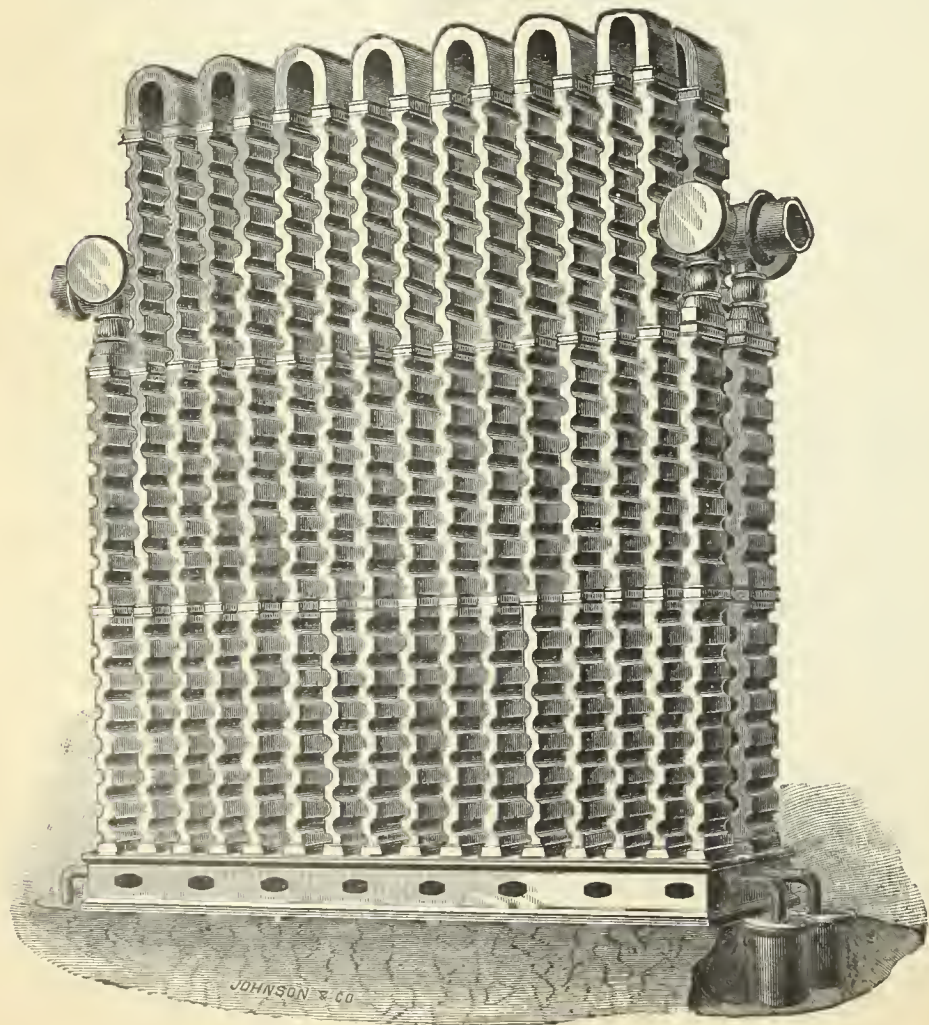

We desire to draw the attention of the gas community to the merits of the SINUOUS FRICTION CONDENSER. Companies intending to introduce new condensers into their works will do well to confer with us and examine plans and estimates before contracting for any other pattern. The FRICTION CONDENSER is now in use at the gas works located in the following places:

Portland, Me.	Brookline, Mass.	Pawtucket, R. I.	Frederickton, N. B.
Newport, R. I.	Chelsea, Mass.	Jamaica Plain, Mass.	St. John, N. B.
Gloucester, Mass.	Woburn, Mass.	Attleboro, Mass.	Paterson, N. J.
Newton & Water- town, Mass.	Peoria, Ill.	Calais, Me.	Dover, N. H.
	Clinton, Mass.	Fall River, Mass.	Waltham, Mass.
		Nassau Works, Brooklyn, N. Y.	

DAVIS & FARNUM MFG. CO.

MANUFACTURERS OF

Gas and Water Pipes,

AND

GAS AND WATER MACHINERY

OF THE MOST APPROVED PATTERN.

Also, Gasholders and Iron Roofing.

Orders from Gas and Water Companies promptly attended to.

WALTHAM, MASS.

Boston Office, Room 55, Mason Building, 70 Kilby Street.

BARTLETT, HAYWARD & CO.

Baltimore, Md.

Munich Regenerative Furnace, System Drs. Schilling & Bunte.

Greatest durability; minimum of attention; complete distillation in 3½ hours; 10 to 13 pounds of coke to hundred-weight of coal; no clinker; no carbonic oxide in regenerative flues.

TWO AND THREE-LIFT TELESCOPIC GASHOLDERS,

With Wrought Iron Tanks, constructed above ground, of any magnitude.

Condensers, Scrubbers, Purifiers, Bench Castings, Roofs, Boilers, Etc.

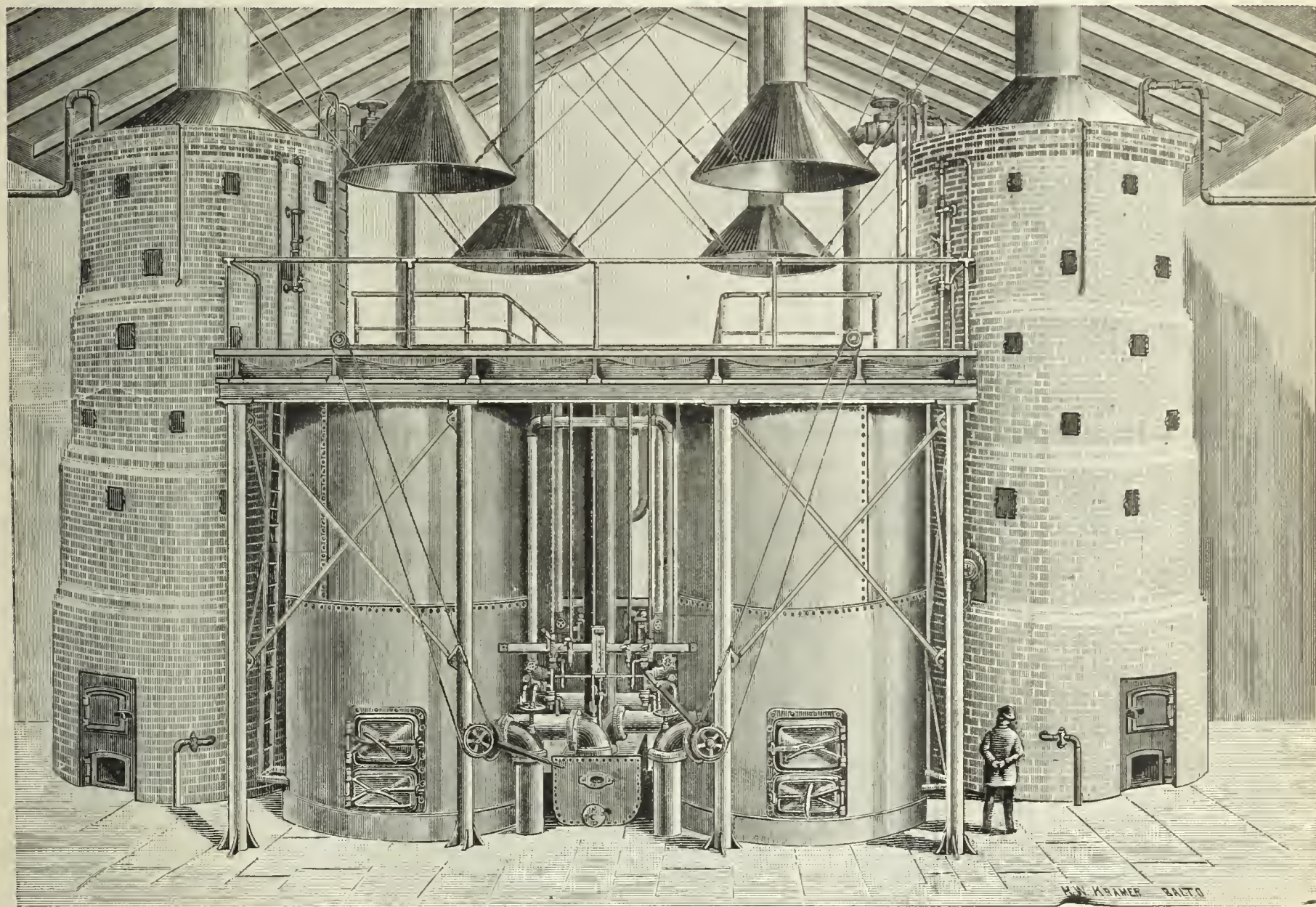

The Wilkinson Water Gas Process.

Introducing the Munich Regenerative Furnace for Coal Gas, we find on the part of many Gas Companies the desire to combine to a greater or less extent an efficient system of making high candle power Water Gas; and with a view of enabling this to be done WITHOUT EXCESSIVE CHARGES FOR PATENT RIGHTS, ETC., we have acquired, by purchase, the exclusive right to construct all the Water Gas Apparatus under the valuable "Wilkinson" Patents.

The results obtained by this Process are far better than those obtained by any other apparatus, especially where an illuminating gas of high candle power or a fuel gas of intense temperature is required.

The Process is uninterrupted, making gas of uniform quality and quantity. Its greatest advantages are maximum production with minimum material and labor, combined with great durability of apparatus.

The Process is in successful operation at the works of the N. Y. Mutual Gas Company, New York; Consolidated Gas Company, Baltimore, Md.; the Hudson County Gas Light Company, of Hoboken, N. J.; and at Rye, N. Y.

We shall be glad to give further detailed information upon application.

Sole Agents for the Celebrated Hazelton Boiler.

BARTLETT, HAYWARD & CO.

EXHAUSTERS.

EXHAUSTERS.

PROCESSES.

NATIONAL GAS LIGHT AND FUEL COMPANY,

No. 218 La Salle Street, Chicago.

THE SPRINGER SYSTEM

OF

Fuel and Illuminating Water Gas Works.

REFERENCES.

People's Gas Light and Coke Co.....Chicago, Ill.
 Elgin National Watch Co.....Elgin, Ill.
 C. R. I. & P. R. R. Shops.....Chicago, Ill.
 Decatur Gas Light and Coke Co.....Decatur, Ill.
 Niles Gas Light Co.....Niles, Mich.
 Newton Illuminating Co.....Newton, Kansas.
 Wellington Light and Heat Co.....Wellington, Kansas.
 Chippewa Falls Gas Light Co.....Chippewa Falls, Wis.
 Elkhart Gas Light and Coke Co.....Elkhart, Ind.
 Madison City Gas Light Co.....Madison, Wis.
 South Bend Gas Light Co.....South Bend, Ind.
 Sheboygan National Gas Co.....Sheboygan, Wis.
 Salina Gas Light Co.....Salina, Kansas.
 The Rathbun Co.....Deseronto, Prov. Ont.
 Jefferson City Gas Light Co.....Jefferson City, Mo.

Mankato Gas Light Co.....Mankato, Minn.
 Minneapolis Gas Light and Coke Co.....Minneapolis, Minn.
 Lima Gas Light Co.....Lima, Ohio.
 Bellevue Water and Fuel Gas Light Co..... } Bellevue, Campbell
 } County, Ky.
 Bucyrus Gas Light and Fuel Co.....Bucyrus, Ohio.
 Morris Gas Co.....Morris, Ill.
 Los Angeles Gas Co.....Los Angeles, Cal.
 San Diego Gas Fuel and Electric Lt. Co.....San Diego, Cal.
 Jackson National Gas Co.....Jackson, Mich.
 Sioux Falls Gas Co.....Sioux Falls, Dak.
 Dakota Gas and Fuel Co.....Grand Forks, Dak.
 St. Johns Mutnal Gas Co.....St. Johns, Mich.
 Stillwater Gas Light Co.....Stillwater, Minn.
 St. Paul Gas Light Co.....St. Paul, Minn.

GUARANTEED ESTIMATES of Cost of Gas Furnished on Application.

ROOTS' NEW GAS EXHAUSTER.

St. Louis, Mo., }
 March 21, 1887. }
 Messrs. P. H. & F. M. Roots, Connorsville, Ind.:
 Dear Sirs—In 1872 one of your No. 5 Exhausters was placed in these works, and worked satisfactorily. In March, 1885, it was replaced by one of your No. 6 Exhausters. The latter has been in almost constant use the past two years, has worked up to all my expectations, and is to-day in apparently as good condition as when first set up. It has not cost one cent for repairs in all that time. I have also

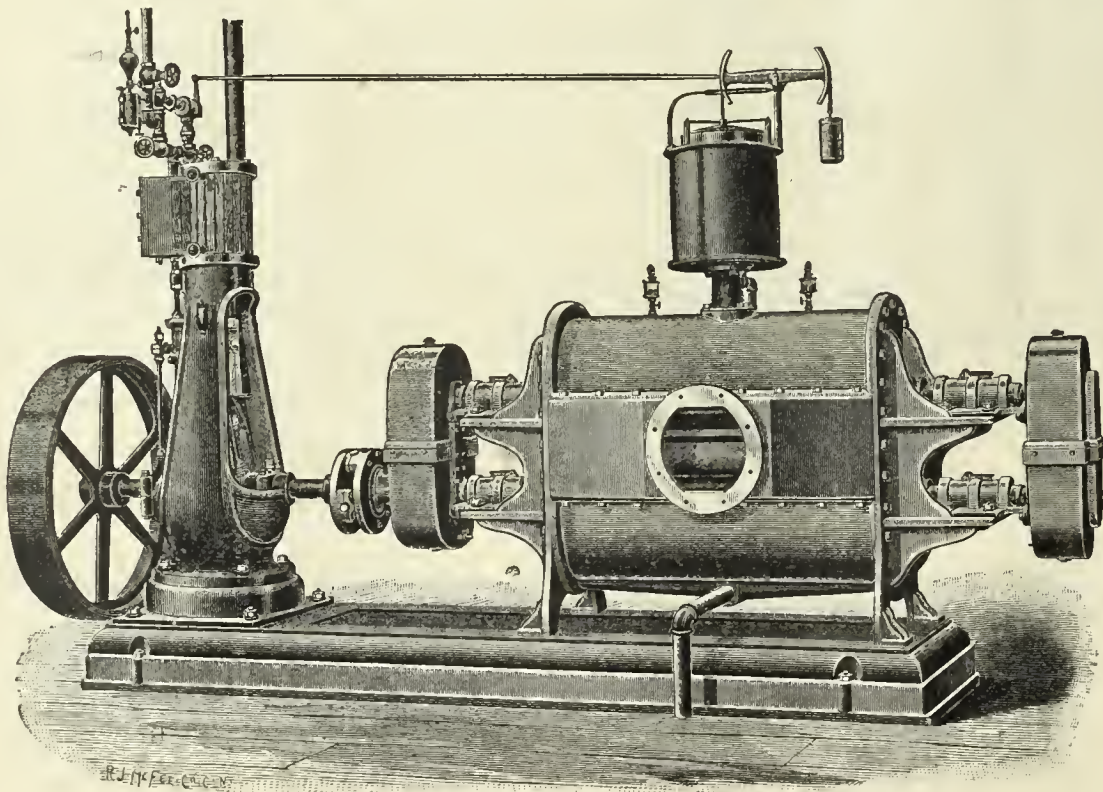

had one of your No. 1 Exhausters, with Engine on same bed-plate, fitted with your valves and Huntoon Governor, placed in a small works under my control, and in its operation it seems as near perfection as I ever expect an Exhauster to become. Without in the least disparaging Exhausters of other makes, I may say that your Exhauster may be safely recommended as unsurpassed by any other, to those requiring such machines.

Yours respectfully,
 FREDERIC EGNER,
 Eng. and Supt.

CONSTRUCTED ON ENTIRELY NEW PRINCIPLES.

THE ONLY EXHAUSTER MADE IN WHICH

The Internal Operating Parts Consist of Only Two Pieces, Each Cast Entire in One Piece.

Send for Descriptive Catalogue and Price List.

P. H. & F. M. ROOTS, Patentees and Manufacturers, **CONNERSVILLE, IND.**

S. S. TOWNSEND, Gen. Agt., 22 Cortlandt St., N. Y. COOKE & CO., Selling Agts., 22 Cortlandt St., N. Y.

CONNELLY & CO., LTD.,

SOLE MANUFACTURERS OF THEIR PATENTED SPECIALTIES.

"IRON SPONGE." Saves money, saves labor, and is the most efficient purifying agent ever offered as a substitute for lime. Now used in every State in the Union, and purifying daily over twenty-five million cubic feet. Should be used in every gas works. Its own saving will pay for it many times over.

AUTOMATIC GOVERNOR. Has been on the market but two years, and in that time has been introduced more generally than any invention ever designed for use in gas works. Over one hundred of them now in use. Sensitive; reliable; perfectly automatic; reduces leakage; satisfies consumers, and gives great relief to the Manager. No gas works is complete without one of these machines.

STEAM JET EXHAUSTER. Designed particularly for small works. Combines Exhaust Tube, Steam Governor, Gas Compensator, and Bye-Pass Valves in the most compact form possible; occupies but little space; uses very little steam; operated by ordinary workmen; saves formation of carbon in retorts; increases yield 10 to 15 per cent. Specially adapted for mixing air with oil gas. No works too small to use them profitably.

Prices given on all our specialties delivered at any point in the United States. Correspondence solicited.

CONNELLY & CO., LTD., No. 177 Broadway, New York City.

WILBRAHAM GAS EXHAUSTER AND ENGINE COMBINED.

WILBRAHAM BROS.,
PHILADELPHIA, PA.

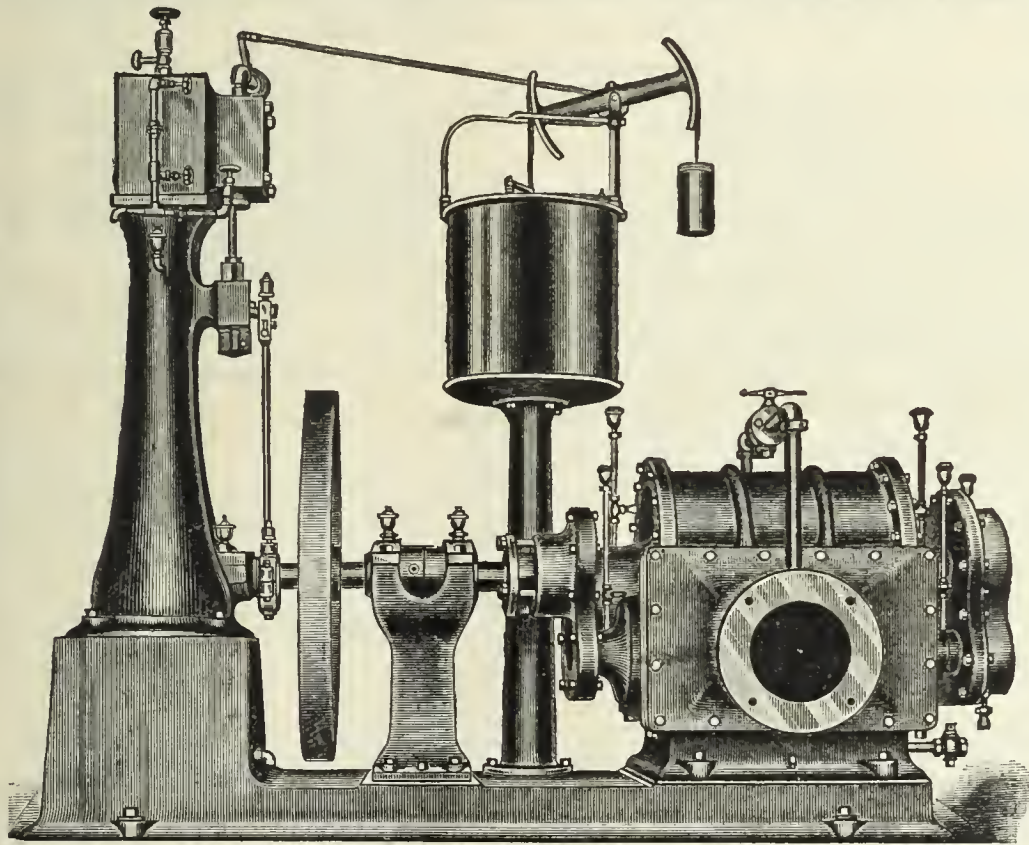

JARVIS ENGINEERING CO.,

61 Oliver St., Boston, Mass.

CONTRACTORS FOR ERECTING

COMPLETE STEAM OUTFITS FOR ELECTRIC LIGHTING STATIONS.

Steel Boilers set with Jarvis Pat. Boiler Setting

To burn **COKE SCREENINGS** for Fuel.

ARMINGTON & SIMS CO. ENGINES,

Belting direct to Dynamos, without using Shafting.

SEND FOR CIRCULARS.

REFERENCES.—Charlestown Gas & Electric Light Co., Charlestown, Mass.; Schenectady Gas & Electric Light Co., Schenectady N. Y.; Brookline Gas Co., Brookline, Mass.

Practical Electric Lighting,

By A. BROMLEY HOLMES, A.M.I.C.E.

With 87 Illustrations. Third Edition. Price, \$1.00.

Electric Light Primer.

By CHARLES L. LEVEY.

A simple and comprehensive Digest of all the most important facts connected with the running of the Dynamo and Electric Lights, with Precautions for Safety, etc.

Price, 50 cents.

A. M. CALLENDER & CO., 42 Pine St., N.Y.

THE CLERK GAS ENGINE CO.,

Main Office, 1012, 1014, 1016, 1018 Filbert St., Philadelphia, Pa.

WM. W. GOODWIN, Prest.

E. STEIN, Sec.

S. LEWIS JONES, Asst. Sec.

A. J. DOTY, Supt.

The utility and convenience of the Gas Engine being no longer an open question, it only remains now for intending purchasers to select the BEST. We claim for the CLERK GAS ENGINE that it is equal to any other manufactured as regards steadiness in running, simplicity, and ease of keeping in repair, and that it gives the greatest amount of power for the least money (both in first cost and expense of running) of any engine made. In support of this claim we refer to the test of the Gas Engines made under the direction of the American Institute of New York, in December, 1885, and heretofore published in these columns. These engines are especially adapted for continuous running under heavy loads, and we can refer to Engines which have run 22 hours a day for months at a time

Made in Sizes of 5, 10, 15, 20, and 25 Horse Power. All Engines Guaranteed for One Year.

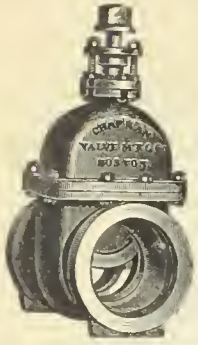

CHAPMAN VALVE MANUFACTURING CO.,

MANUFACTURERS OF

Valves and Gates for Gas, Ammonia, Water, Etc.

Also, Gate Fire Hydrants With and Without Independent Nozzle Valve. All Work Guaranteed.

WORKS & GEN'L OFFICE:
Indian Orchard, Mass.

TREASURER'S OFFICE:
72 Kilby & 112 Milk Sts, Boston, Mass.

LUDLOW VALVE MFG. CO.

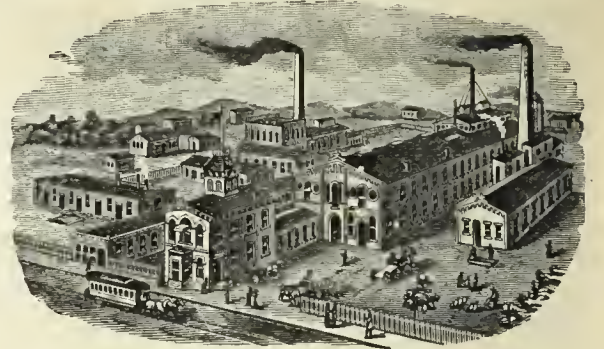

OFFICE AND WORKS,

93S to 954 River Street and 67 to 83 Vail Av
TROY, N. Y.

How to Reduce Leakage to Its Minimum.

USE

HOPPER'S AUTOMATIC DIFFERENTIAL GAS GOVERNOR.

Needs No Attention. Simple, Reliable, Perfectly Automatic.

"Nearly Thirty in Use."

BYE-PASSES, DRY CENTER VALVES, PRESSURE REGISTERS. Also, GOVERNORS FOR STREET MAINS, *NOT DIFFERENTIAL*, and for EXHAUSTERS, GAS ENGINES, etc.

Our new Bye-Pass is threefold in its action—passes gas through, or bye-passes, or shuts off entirely. Correspondence solicited; information given. Send for circulars and testimonials.

T. C. HOPPER & CO., - - No. 2227 Wood Street, Philadelphia, Pa.

Hydraulic Main Dip Regulators, also Check Valves, Foot Valves, Yard-wash and Fire Hydrants. Send for Circulars.

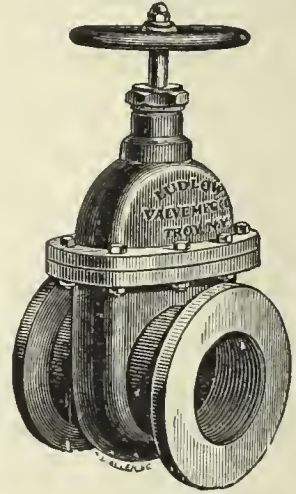

Valves.—Double and Single Gate, 1/2 in. to 48 in., outside and inside Screws. Indicator, etc., for Gas, Water, Steam, and Oil. Send for Circulars.

MILLS' REVERSIBLE LIME TRAY,

AND

WOODWORK

Of Every Description

NEEDED BY GAS WORKS.

SEND FOR CIRCULAR AND PRICE LIST TO

GEORGE A. MILLS,

Canton Av. & President St., Baltimore, Md.

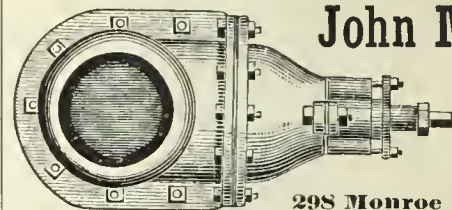
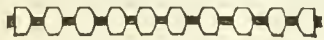
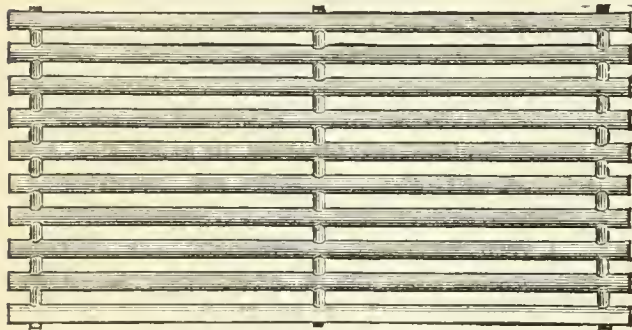

John McLean

Manufacturer of

GAS VALVES.

298 Monroe Street, N. Y.

GEO. SHEPARD PAGE,

No. 69 Wall Street, N. Y. City.

REPRESENTING

THE BOWER GAS LAMP.

C. & W. Walker's Carbonic Acid & Tar Extracting Washer

B. DONKIN & CO.'S PAT. IMP. GAS VALVE.

Young & Beilby's Patents. Henry Aitkin's Patents.

R. P. SPICE, London, Eng. HENRY SIMON, Manchester, Eng.

MITCHELL, VANCE & CO.,

MANUFACTURERS OF

Chandeliers

and every description of

GAS FIXTURES.

Also manufacturers of Fine Gilt Bronzes and Marble Clocks, warranted best time-keepers. Mantel Ornaments, etc.

Salesrooms, 836 Broadway, N. Y.

Special Designs furnished for Gas Fixtures for Churches, Public Halls, Lodges, etc.

GAS AS A SOURCE OF LIGHT, HEAT, AND POWER.

By C. J. R. HUMPHREYS

A Pamphlet of twenty-nine pages, treating of the use of Gas as a source of Light, Heat, and Power.

DESIGNED FOR DISTRIBUTION BY GAS COMPANIES AMONG THEIR CUSTOMERS AND OTHERS.

Price, 10 cents each, \$5 per 100, \$50 per 1,000.

Gas Companies can have their own imprint placed on cover without extra charge. All orders to be sent to

A. M. CALLENDER & CO.,

No. 42 Pine Street, N. Y. City.

GAS STOVES.

GAS STOVES.

GAS STOVES.

THE AMERICAN METER CO.,

MANUFACTURERS OF

GAS COOKING AND HEATING STOVES.

Gas
Heating
Stoves
in
all
Sizes
for
Parlors,
Chambers
and
Offices.

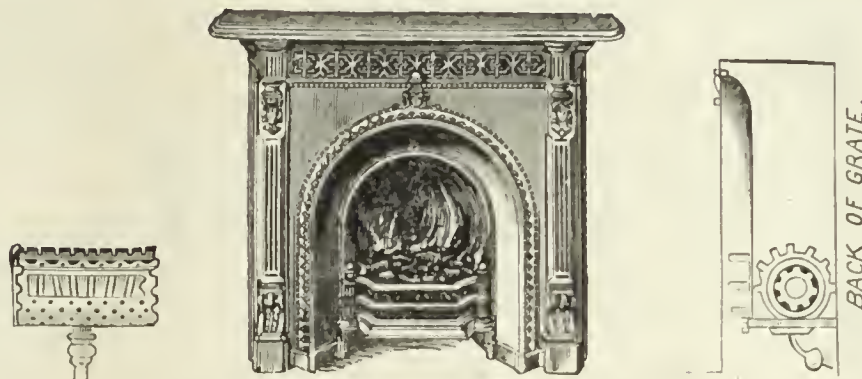

Verity's and Wilson's Patent Gas Fires For Open Fireplaces.

Gas
Cooking
Stoves
and
Ranges
in
all
Sizes
for
Family
and
Hotel
Use.



Catalogues and Price Lists on Application.

Catalogues and Price Lists on Application.

MANUFACTORIES,

508 to 514 West Twenty-second St., N. Y.

Arch and Twenty-second St., Phila

Nos. 244 & 246 North Wells Street, Chicago, Ill.

AGENCIES,

No. 177 Elm Street, Cincinnati, Ohio.

No. 222 Sutter Street, San Francisco Cal.

No. 810 North Second Street, St. Louis, Mo.

GAS STOVE SHOW ROOMS, No. 223 Sixth Avenue, New York City.

RETORTS AND FIRE BRICK.

J. H. CAUTIER & CO.,
CORNER OF
GREENE AND ESSEX STREETS,
JERSEY CITY, N. J.

MANUFACTURERS OF
**Clay Gas Retorts,
Gas House Tiles,
Fire Bricks, Etc. Etc.**

Ground Clay, Fire Brick and
Fire Sand in Barrels,

J. H. GAUTIER. T. B. GAUTIER.
C. E. GREGORY. C. E. GAUTIER.

BROOKLYN
Clay Retort & Fire Brick Works,
(EDWARD D. WHITE & CO.)
Manufacturers of Clay Retorts, Fire Brick,
Gas House and other Tile.
VAN DYKE, ELIZABETH, RICHARDS & PARTITION STS.
Office, 88 Van Dyke St., Brooklyn, N. Y.

RETORTS AND FIRE BRICK.

LAGLEDE FIRE BRICK MFG. CO.,
MANUFACTURERS OF
Fire Brick, Gas Retorts,

AND
ST. LOUIS STANDARD SEWER PIPE.
Blast Furnace and Cupola Linings, every description of Fire
Clay Material, Fire Clay Flue Linings, Chimney Tops
Dry Milled and Crude Fire Clays, etc.

OFFICE AND DEPOT
901, 903, and 905 Pine Street,
ST. LOUIS, MO.

ESTABLISHED IN 1845.

B. KREISCHER & SONS,
OFFICE FOOT OF HOUSTON ST., E.R., N.Y.

**Gas Retorts,
TILES, FIRE BRICK.**

AND EVERYTHING IN THE FIRE CLAY LINE.

RETORTS AND FIRE BRICK.

MANHATTAN
FIRE BRICK & ENAMELLED CLAY
RETORT WORKS.
ADAM WEBER.

**CLAY GAS RETORTS
AND RETORT SETTINGS
FIRE BRICKS, TILES, ETC.,**

Office and Works, 15th Street and Avenue C., N. Y.



—ESTABLISHED 1864.—

Works,
LOCKPORT STATION, PA.

JAMES GARDNER, JR.,

Successor to WILLIAM GARDNER & SON.

Office, Rooms 19 & 20, Lewis Block,
PITTSBURGH, PA, P. O. Box 373.

Fire Clay Goods for Gas Works.

CHAS. H. SPRAGUE & SON, No. 70 KILBY STREET, BOSTON, MASS., Agents for the New England States.

OFFICE, 418 to 422 East 23d St., New York.

ESTABLISHED 1856.

WORKS, PERTH AMBOY, NEW JERSEY.

HENRY MAURER & SON,
Excelsior Fire Brick & Clay Retort Works
CLAY GAS RETORTS, BENCH SETTINGS, FIRE BRICK, TILES, ETC.

CHICAGO
Retort & Fire Brick Works,
OFFICE AND FACTORY,
Clark, Forty-Fifth, and La Salle Streets,
CHICAGO, ILL.
GEORGE C. HICKS, PRES. PAUL P. AUSTIN, SEC. & TREAS.
STANDARD
Clay Retorts and Settings.
BLOCKS & TILES
of every Shape and Size to Order.
Standard Fire Bricks.

GEROULD'S IMPROVED RETORT CEMENT.
A Cement for patching retorts, putting on mouthpieces, and
making up all bench-work joints. This Cement is mixed ready
for use. Economic and thorough in its work. Fully warranted
to stick. For recommendations and price list address
C. L. GEROULD & CO.,
5 & 7 Skillman St., Brooklyn, N. Y.
Western Agent, H. T. GEROULD, Mendota, Ill.

OAKHILL
GAS RETORT & FIRE BRICK
Works.
Proprietors,
PARKER-RUSSELL MINING & MFG. CO.
City Office, 711 Pine Street,
ST. LOUIS, MO.

Our immense establishment is now employed almost entirely in
the manufacture of
MATERIALS FOR GAS COMPANIES.
We have studied and perfected three important points. Our re-
torts are made to stand changes of temperature, the strongest
heats of the furnace, and the abrasion of feeding and emptying.
Our customers are in almost every State of the Union, to all of
whom we refer

THOS. SMITH, Prest. AUGUST LAMBLA, Vice-Prest. & Sup
BALTIMORE
RETORT & FIRE BRICK CO.
MANUFACTORY AT
LOCUST POINT, BALTIMORE, MD.
Connection with the City by Telephone.
**Clay Retorts, Blocks & Tiles,
FIRE BRICK, FIRE CLAY,
AND FIRE CEMENT.**

Red and Buff Ornamental Tiles and Chim-
ney Tops. Drain and Sewer Pipe (from
2 to 30 inches). Baker Oven Tiles
12x12x2 and 10x10x2.
WALDO BROS., 88 WATER ST., BOSTON, MASS
Sole Agents the New England States.

EVENS & HOWARD,

916 Market St., St. Louis. Mo.
Works, Howard Station, Mo. Pacific R.R.

Fire Brick, Gas Retorts

AND
RETORT SETTINGS.

Sewer Pipe, 3 to 24 in. diameter.
Glass Pot Clay, Ground Fire Clay, in barrets and in bulk. All kinds of Fire Clay Goods.

Cincinnati Gas Retort & Fire Brick Works.
—ESTABLISHED 1872.—

CHAS. TAYLOR,

MANUFACTURER OF

Gas Retorts, Fire Brick, and Tile.

Blast Furnace Linings, Cupola Blocks, Boiler Tiles, Grate Settings, and Stove Linings. Fire Cement, Fire Clay, Fire Sand, and all other Fire Clay Goods.

Branch Works, New Cumberland, W. Va.
GENERAL OFFICE AND WORKS,
Burns St., Cincinnati, Ohio.

EMIL LENZ,

2 & 4 Stone St., N. Y. City.

CLAY GAS RETORTS

(ENAMELED.)

Fire Brick, Blocks & Tiles.

FIRE CEMENT, RETORT ENAMEL, RETORT CEMENT, ETC., ETC.

Regenerative and Half-Regenerative Benches.
PORTLAND CEMENT.

Correspondence Respectfully Solicited.

GAS vs. ELECTRIC LIGHT.

We would invite attention to the able and exhaustive argument of General A. Hickenlooper, President of the Cincinnati Gas Light and Coke Company, contained in a handsome pamphlet of 96 pages, entitled

"EDISON'S INCANDESCENT ELECTRIC LIGHTS FOR STREET ILLUMINATION. REPORT OF AN ARGUMENT DELIVERED BY A. HICKENLOOPER BEFORE THE COMMITTEE ON LIGHT, MUNICIPAL COUNCIL, CITY OF CINCINNATI, JULY 22, 1886."

This is a subject of special interest to all Gas Light Companies.

Prices.

25 copies.....	\$7.50	100 copies.....	\$22.50
50 copies.....	12.50	250 copies.....	50.00

A sample copy will be sent by mail on receipt of 50 cts.

A. M. CALLENDER, & CO., 42 PINE ST., N. Y. CITY.

PATENTS.

FRANKLIN H. HOUGH,

Solicitor of American & Foreign Patents

925 F. ST., WASHINGTON, D. C.

(NEAR U. S. PATENT OFFICE.)

Personal attention given to the preparation and prosecution of applications for Letters Patent. All business before the U. S. Patent Office attended to for moderate fees. **No Agency in the United States possesses superior facilities for obtaining Patents,** or for ascertaining the patentability of inventions. Copies of patents furnished for 25 cents each. Correspondence solicited.



STEPHEN A. MORSE, President.
GODFREY REBMANN, Vice-Pres.

M. B. DYOTT,
Superintendent.

EDWIN F. MORSE, Secretary.
CARLTON M. WILLIAMS, Treas.

STANDARD GAS LAMP CO.,

Office, 411 Cherry St. Factory, 1101, 1103 & 1105 Frankford Av.

Philadelphia, Pa.

It is to the interest of Gas Companies and Cities to use Dyott's Patent Champion Lamps, which give double the light with the same consumption of gas, and will save 50 per cent. over others in cost of keeping in repair. Gas Companies and others intending to erect Lamps of any description will do well to communicate with us. Special Drawings furnished and Estimates given on application upon Architects', Engineers' or our Draughtsmen's Plans.

Our Patent System of Instantaneously Lighting Gas (without electricity) for R. R. Depots is unequalled. Our High Candle Power Burner is superior to the Electric Light or any other High Candle Burner. We manufacture every description of Ornamental Lamps.

KLOENNE & BREDEL

IMPROVED REGENERATIVE FURNACES.

Self-Sealing Mouthpieces & Bridge-Pipes, Retort Houses,
WASHER-SCRUBBERS
Gasholders, and Complete Gas Works.

Refers, by permission, to Mr. Eugene Vanderpool, of Newark, N. J.; Mr. E. G. Cowdery, of Milwaukee, Wis.; and Mr. Theo. Forstall, of Chicago, Ill. For further information apply to

FRED. BREDEL, 332 East 17th St., N. Y. City.

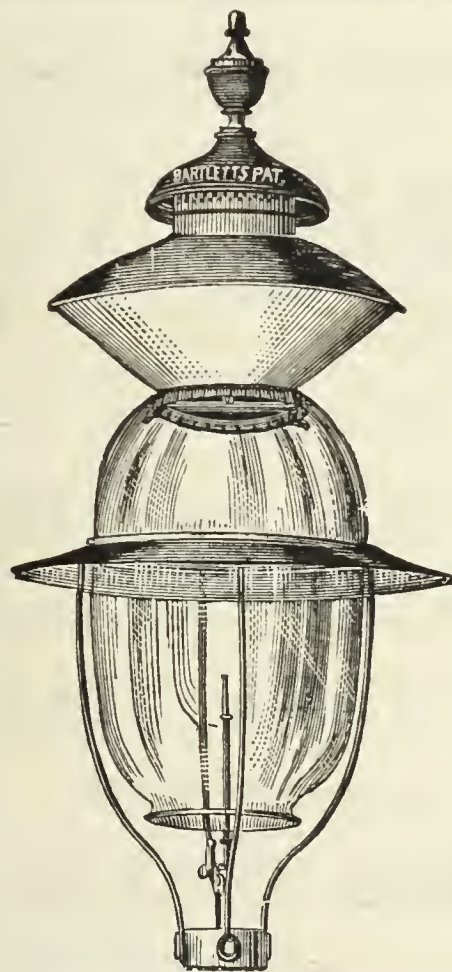

G. S. COOK, Pres. THOS. DAVENPORT (late Davenport Bros.), Sec. & Treas

BARTLETT

Street Lamp Mfg. Co.

MANUFACTURERS OF

Bartlett's Patent

GLOBE LAMPS.

FOR

Streets, Parks, Railroad Stations, Public Buildings, Etc.

LAMP POSTS A SPECIALTY.

Office and Salesroom

40 & 42 College Place, N. Y. City.

Gas Companies and others intending to erect lamps and posts will do well to communicate with us.

Ferric Oxide for Gas Purification.

Ferric Oxide, as ground, screened, and prepared by me for purifying purposes, has now been in use for several years by many of the gas works throughout the country, including Detroit, Chicago, Milwaukee, East Saginaw, Burlington (Iowa), Ann Arbor, etc. It has proved, as I believe, the **Most Effective and Economical Agent** now in use. I am prepared to furnish the Oxide by the 100 lbs. or in car load lots, and will be pleased to give price f.o.b. cars at Ann Arbor or at place of destination. Address

S. H. DOUGLAS, Prest. Ann Arbor (Mich.) Gas Light Co.

GAS AND WATER PIPES.

GAS AND WATER PIPES.

ENGINEERS.

SAM'L R. SHIPLEY, Pres.
HENRY B. CHEW, Treas.

JAS. P. MICHELLON, Sec.
WM. SEXTON, Supt.

GLOUCESTER IRON WORKS,
GLOUCESTER CITY, N. J.



Cast Iron Gas & Water Pipes, Stop Valves, Fire Hydrants, Gasholders. &c.

Office No. 6 North Seventh Street, Philadelphia.

MATTHEW ADDY, President.

W. L. DAVIS, Selling Agent.

GEO. P. WILSHIRE, Sec. & Treas.

Cincinnati and Newport Iron and Pipe Company,
NEWPORT, KY.

Lamp Posts
AND
BENCH CASTINGS

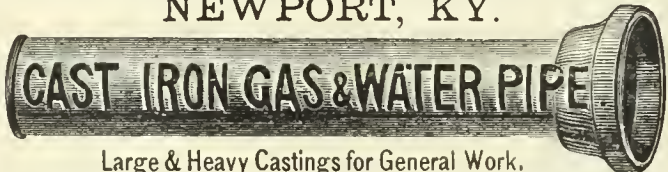

Branch
AND
SPECIAL CASTINGS

A Specialty.

Large & Heavy Castings for General Work.

FOR GAS & WATER CO'S.

Manufacture Pipe from 2 to 48 inches. All work guaranteed first quality.

Pancoast & Rogers.

WROUGHT IRON PIPE,

VALVES AND GATES,

Cast Iron Gas & Water Pipe.

28 Platt and 15 Gold St., New York.

Water & Gas Pipe.

RUSTLESS

Send for New Catalogue.

RUSTLESS

The WELLS RUSTLESS IRON COMPANY,

Nos. 7 and 9 Cliff Street, New York City.

The Management of Small Gas Works.

By C. J. R. HUMPHREYS. Price, \$1.

A running commentary on the different sections of gas management with reference to small undertakings, with some notes on the erection of the necessary plant.

A. M. CALLENDER & CO., 42 Pine St., N. Y.

P. D. WANNER, Chairman. A. H. MELLERT, Sec. & Treas.

MELLERT FOUNDRY & MACHINE CO., Ltd.
Reading, Pa.



Specials—Flange Pipe, Valves and Hydrants, Lamp Posts, Retorts, etc.

General Foundry and Machine Work.

JOHN FOX, Selling Agent. 160 Broadway, N. Y.

THE OHIO PIPE COMPANY,

MANUFACTURERS OF

Cast Iron Gas & Water Pipe,

BRANCH AND SPECIAL CASTINGS.

Gas-House Bench Castings, Hydraulics, Lamp Posts, Flange Pipe and Specials, Architectural Castings, Building Columns, Joists, Cellar Grates, Sash Weights, etc.

GENERAL FOUNDERS AND MACHINISTS.

Columbus, Ohio.

M. J. DRUMMOND,



SPECIAL CASTINGS AND LAMP POSTS.

Equitable Building, 120 Broadway, N. Y.

JOS. R. THOMAS, C.E.,

May be Consulted on all Matters Relating to Gas Works and Gas Manufacture.

ADDRESS THIS OFFICE.

WM. MOONEY

(Successor to WM. FARMER)

27 Pearl Street, N. Y. City.

(One door from Whitehall Street.)

CONTRACTOR FOR THE ERECTION OF GAS WORKS, OR APPARATUS OF ANY CAPACITY. AGENT FOR WM. FARMER'S PATENTS.

Plans and Specifications Furnished.

WM. HENRY WHITE,

CONSULTING AND CONSTRUCTING

Gas Engineer & Contractor

Estimates, Plans, and Specifications furnished for new works or extensions of existing works.

No. 32 Pine Street, New York City.

Correspondence solicited.

WM. GARDNER,

Gas Engineer,

Lewis Block, Room 20, Pittsburgh, Pa.

Those who intend to make alterations in existing gas plants, or who contemplate the erection of new works, will find it to their interest to open correspondence with the above. Plans made and estimates furnished.

GAS LAMPS.

SCRUBBERS AND CONDENSERS.

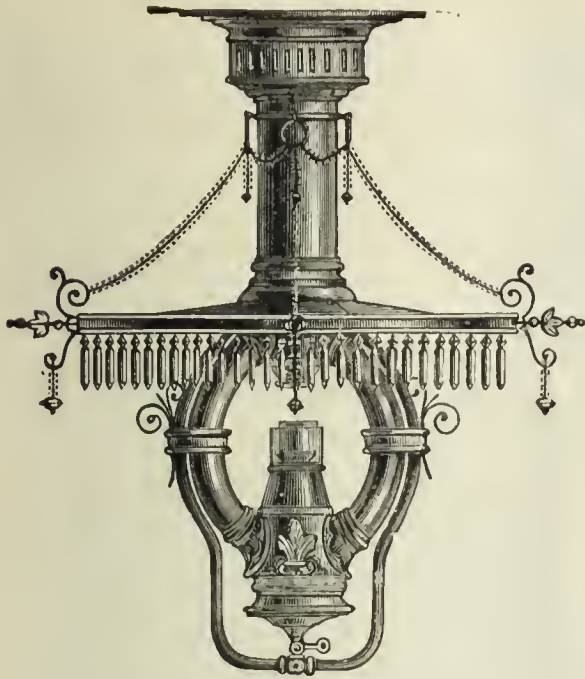

SIEMENS LAMP.

The Siemens and Lungren REGENERATIVE GAS LAMPS.

A System of Burning Gas whereby its Illuminating Power is Increased from 300 to 400 per ct. without the Expense, Trouble and Annoyance resulting from the use of Hydrocarbon Enriching Material.

The Siemens-Lungren Company received the only Silver Medal or Highest Award for Gas Burners at the "Novelties" Exhibition of the Franklin Institute, held at Phila., Oct., '85.

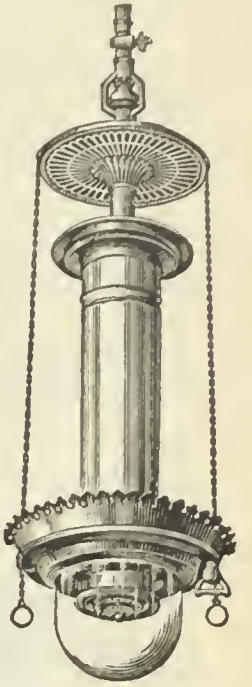

LUNGREN LAMP

THIRTEEN CANDLE POWER PER CUBIC FOOT OF GAS!

This result is obtained

SIMPLY BY THE SCIENTIFIC APPLICATION OF THE REGENERATIVE PRINCIPLE.

Consequently this largely increased illumination is always maintained without further cost and frequent attention.

THE SIEMENS-LUNCREN COMPANY,

N. E. Cor. 21st. St. and Washington Av., Phila., Pa.

KIRKHAM, HULETT & CHANDLER, Limited,
London, S. W., England.

PATENT "STANDARD" WASHER-SCRUBBERS.

Following are extracts from letters received from some of the Gas Light Companies now using the "Standard" Washer-Scrubber:

SAN FRANCISCO, Sept. 21, 1887.
GEO. SHEPARD PAGE, Esq.:
Dear Sir—In reply to yours, would say that the ammonia is entirely removed from the gas by the use of the "Standard" Washer-Scrubber.
Yours truly, J. B. CROCKETT, Prest.,
San Francisco Gas Lt. Co.

BOSTON, MASS., Aug. 30, 1887.
GEO. SHEPARD PAGE, Esq.:
Dear Sir—The "Standard" Washer-Scrubber at these works is giving good satisfaction, and the increased amount of ammonia eliminated from the gas by its use enables us to obtain a larger income from the ammoniacal liquor.
Truly yours, THOS. J. PISHON, Supt.,
Roxbury Gas Lt. Co.

GEORGETOWN, D. C., Sept. 27, 1887.
GEORGE SHEPARD PAGE, Esq.:
Dear Sir—The "Standard" Washer-Scrubber, together with all the work of connecting the same with these works, has given entire satisfaction.
Truly yours, J. B. CATHELL, Supt.,
Georgetown Gas Lt. Co.

BROOKLYN, N. Y., Sept. 8, 1887.
GEORGE SHEPARD PAGE, Esq.:
Dear Sir—By the use of the "Standard" Washer-Scrubber at these works the ammonia is entirely removed from the gas, and our income from the ammoniacal liquor has been increased 100 per cent.
Yours truly, C. W. BLODGET, Sec.,
Williamsburgh Gas Lt. Co.

GEO. SHEPARD PAGE, 69 WALL STREET, NEW YORK,
Agent for the Western Hemisphere,

GAS WORKS APPARATUS AND CONSTRUCTION.

GAS WORKS APPARATUS AND CONSTRUCTION.

WORKS: { MILLVILLE, N. J.
FLORENCE, "
CAMDEN, "

R. D. WOOD & CO.,

OFFICES: { 400 CHESTNUT ST.,
PHILADELPHIA.

GAST-IRON PIPE 1½ to 72 Inches in Diameter.

Water Machinery and Gas Apparatus.

HEAVY CASTINGS.

HOLDERS,

PURIFIERS,

FLOORS AND ROOFS,

LAMP POSTS,

CONDENSERS,

FLANGED PIPE,

VALVES,

BENCH WORK,

FIRE HYDRANTS,

METER CASES.

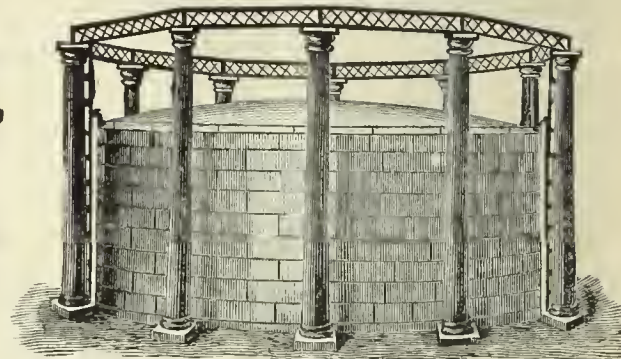
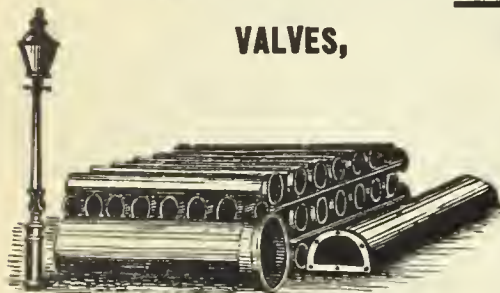

Estimates and Specifications for
NEW WORKS or **EXTENSIONS**
or **ALTERATIONS** of **OLD ONES.**

GASHOLDER TANK CONSTRUCTION, ETC.

Gas Companies and others about to erect Gasholders will find it profitable to consult W. C. WHYTE, who for over thirty years has made a specialty of

Holder Tank Excavation and Mason Work.

Fifty tanks now in operation show the sort of work done. Address

W. C. WHYTE, No. 15 Cortlandt St., N. Y. City.

MORRIS, TASKER & CO.,

Limited,

Builders of Gas Works,

PHILADELPHIA PA.

GASHOLDERS, PURIFIERS, SCRUBBERS, CONDENSERS, EXHAUSTERS,

Bench Castings, Iron Roofs, Lamp Posts

VALVES, STREET MAIN SPECIALS, ETC.,

MANUFACTURED BY

KERR MURRAY MANUFACTURING COMPANY

From 1880 to 1886, inclusive, we erected Gasholders for the following cities, viz.:

Adrian, Mich.	East End Gas Co., Pitts-	Janesville, Wis.	New Castle, Pa.	Valparaiso, Ind.
Akron, Ohio.	burgh, Pa.	Johnstown, Pa.	Niagara Falls, N. Y.	Van Wert, Ohio.
Albuquerque, N. M.	East Saginaw, Mich.	Key West, Fla.	Osawatomie, Kans.	Wabash, Ind.
Altoona, Pa.	Elgin, Ills.	La Crosse, Wis.	Pittsburgh, Pa. (2)	Waco, Texas.
Anderson, Ind.	Evanston, Ills.	Lebanon, Ind.	Plainfield, Ind.	Waukesha, Wis.
Bellaire, Ohio.	Eufaula, Ala.	Lima, Ohio.	Portage City, Wis.	Wheeling, West Va.
Birmingham, Ala.	Frankfort, Ind.	Logan, Ohio.	Sedalia, Mo.	Wellington, Kans.
Bucyrus, Ohio.	Freeport, Ills.	Louisville, Ky.	Sheboygan, Wis.	West Pittsburgh, Pa.
Canton, Ohio.	Galesburg, Ills.	Mankato, Minn.	South Bend, Ind.	Xenia, Ohio.
Circleville, Ohio.	Grafton, West Va.	Mansfield, Ohio.	South Chicago, Ills.	Youngstown, Ohio.
Colorado Springs, Col.	Greensburg, Pa.	Marshalltown, Iowa.	Springfield, Ills.	Ypsilanti, Mich.
Danbury, Conn.	Huntington, Ind. (2)	Meridian, Miss.	Streator, Ills.	
Delaware, Ohio.	Ironton, Ohio.	Minneapolis, Minn.	Topeka, Kans.	
Delphos, Ohio.	Jamestown, N. Y.	Muskegon, Mich.	Uniontown, Pa.	

Under construction, 1887.

Arkansas City, Kans.	Grand Forks, Dakota.	Mobile, Ala.	Santa Fe, N. M.	Fuel Gas and Electric Engi-
Dallas, Texas.	Grand Rapids, Mich.	Pittsburgh, Pa.	Wichita, Kans.	neering Co., Pittsburgh, Pa.
El Paso, Texas.	La Crosse, Wis.	Pine Bluff, Ark.	Lexington, Mo.	Stillwater, Minn.

Estimates, with Plans and Specifications, for new or the rebuilding of old works, furnished on application. Correspondence solicited. Address

KERR MURRAY MANUFACTURING CO.,

A. D. CRESSLER, General Manager.

FORT WAYNE IND.

GAS WORKS APPARATUS AND CONSTRUCTION.

GAS WORKS APPARATUS AND CONSTRUCTION.

JAMES R. FLOYD,
(SUCCESSOR TO HERRING & FLOYD)

Oregon Iron Works,
531 to 543 West 20th St., N. Y.
Practical Builders of Gas Works,
MANUFACTURERS OF
ALL KINDS OF CASTINGS
AND
APPARATUS FOR GAS-WORKS.

BENCH CASTINGS
from benches of one to six Retorts each.
WASHERS: MULTITUBULAR AND
AIR CONDENSERS; CONDENSERS;
SCRUBBERS
(wet and dry), and
EXHAUSTERS
for relieving Retorts from pressure.
BENDS and BRANCHES
all sizes and description.
FLOYD'S PATENT
MALLEABLE RETORT LID.
PATENT
SELF-SEALING RETORT LIDS.
FARMER'S
PATENT BY-PASS DIP-PIPE.
SABBATON'S PATENT
FURNACE DOOR AND FRAME.
BUTLER'S
COKE SCREENING SHOVELS.
GAS GOVERNORS,
and everything connected with well regulated Gas Works at low price, and in complete order.
SELLER'S CEMENT
for stopping leaks in Retorts.
N. B.—STOP VALVES from three to thirty inches—at very low prices.
Plans, Specifications, and Estimates furnished.

THE CONTINENTAL IRON WORKS.

THOS. F. ROWLAND, Prest. WARREN E. HILL and CHAS. H. CORBETT, V.-Presds. THOS. F. ROWLAND, JR., Sec. & Treas.

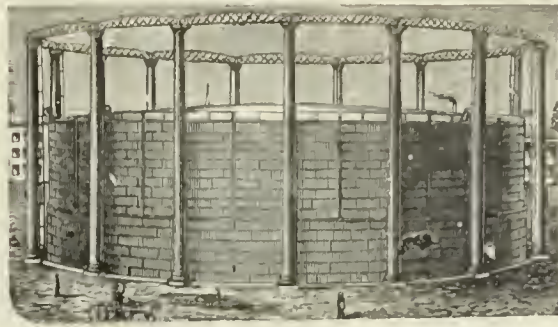

GAS HOLDERS OF ANY MAGNITUDE.

P. O. Station G., BROOKLYN, N. Y.

ENGINEERS AND MANUFACTURERS OF

Gas Holders
CONDENSERS, SCRUBBERS, VALVES,
PURIFIERS, SELF-SEALING RETORT LIDS,
Hydraulic Mains,
And all other articles connected with the manufacture and distribution of Gas.

H. RANSHAW, Prest. & Mangr. WM. STACEY, Vice-Prest. T. H. BIRCH, Asst. Mangr. R. J. TARVIN, Sec. & Treas.

STACEY MFG. CO.,

MANUFACTURERS OF

Single and Telescopic Gasholders,

IRON ROOFS, BRIDGES, LAMP POSTS,
Water and Oil Tanks, Coal Elevator Cars,
COKE CRUSHERS, BENCH CASTINGS,

And all kinds of Wrought and Cast Iron Work used in the erection of Coal and Oil Gas Works. Rolling Mill Machinery and Heavy Castings a Specialty.

Foundry: 33, 35, 37 & 39 Mill Street. **Wrought Iron Works:** 16, 18, 20, 22, 24 & 26 Ramsey Street:

Cincinnati, Ohio.

Bouton Foundry Co.,

FOUNDERS AND MACHINISTS,

CHICAGO, ILL.

Gas Works Apparatus,

PURIFIERS, CONDENSERS,

Bench Work,

SPECIALS, LAMP POSTS,

SCRUBBERS,

Iron Roofs and Floors.

Plans and Estimates furnished for new works or extensions of old works.

1842. **DEILY & FOWLER,** 1887.
Laurel Iron Works.

Address, No. 39 Laurel Street, Philadelphia, Pa.

MANUFACTURERS OF

GASHOLDERS,

Single and Telescopic.

Holder Built 1882 to 1886, Inclusive:

- | | | | | |
|----------------------------|---------------------------|----------------------------|-----------------------------|---------------------------|
| Denver, Col. | Warren, Ohio. | Allegheny, Pa. (2d.) | York, Pa. | Salem, N. J. (3d) |
| Chicago, Ill. (West Side). | Bath, N. Y. | Atlanta, Ga. (2d.) | Chester, Pa. | Omaha, Neb. (2d)] |
| Pittsburgh, Pa. (S. Side) | Lynn, Mass. | N.Y. City (Central Gas Co) | Hazleton, Pa. (2d.) | Lynn, Mass. (2d) |
| Pawtucket, R. I. | New Bedford, Mass. | Lynchburg, Va. (2d.) | State Island, N. Y. | Little Rock, Ark. |
| Brookline, Mass. | Waterbury, Conn. | Saylesville, R. I. | Saugerties, N. Y. | Irvington, N. Y. |
| Sherbrooke, Can. | Deseronto, Can. | Rondout, N. Y. | Clinton, Mass. (Lan. Mills) | South Boston, Mass. |
| Burlington, N. J. (2d.) | Hoosic Falls, N. Y. (2d.) | Atlantic City, N. J. | Chattanooga, Tenn. | Rye, N. Y. (2) |
| Bridgeton, N. J. | Bethlehem, Pa. | Augusta, Ga. | Galveston, Texas. (3d.) | Woodstock, Ont. |
| Bay City, Mich. | Atlanta, Ga. (1st.) | Waltham, Mass. (2) | Omaha, Neb. | Malden, Mass. |
| Erie, Pa. | Savannah, Ga. | Mahanov City, Pa. | Fort Plain, N. Y. | Staten Island, N. Y. (2d) |
| Jackson, Mich. | Montgomery, Ala. | New Castle, Pa. | Brunswick, Ga. | |
| Kalamazoo, Mich. (3d.) | Newport, R. I. | Long Island City, N. Y. | Port Chester, N. Y. | |
| Glen Island, N. Y. | Portland, Oregon. | Macon, Ga. | New Rochelle, N. Y. | |

SMITH & SAYRE MFG. COMPANY,

G. PORTER, Prest.

245 Broadway, N. Y.

CHAS. W. ISBELL, Sec'y.

Machinery & Apparatus for Gas Works

Drawings, Plans, and Estimates Furnished for the Improvement, Extension, or Alteration of Gas Works, or for the Construction of New Works.

Mackenzie's Patent Rotary and Steam Jet Gas Exhausters, Governors, Compensators, Condensers, Washers, Scrubbers. Isbell's Patent Automatic Street Pressure Governor Gas and Water Valves, Hydraulic Main Dip Regulator, Bench Castings, etc. Purifying Boxes and "Standard" Scrubbers. Isbell's Patent Self-Sealing Retort Doors.

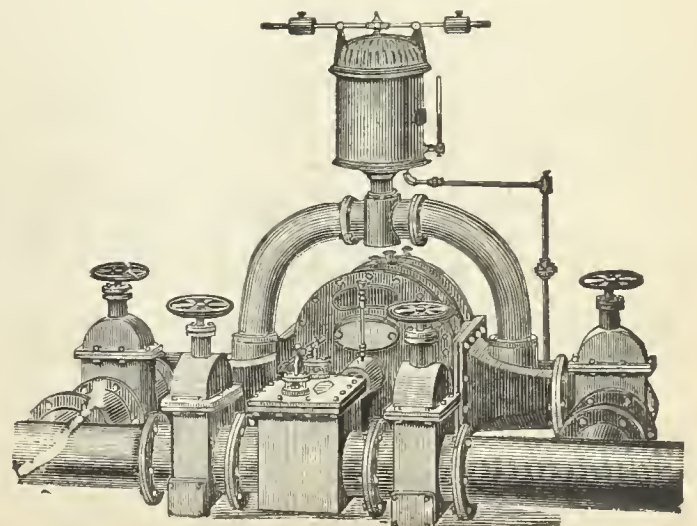

GAS COALS.

CANNEL COALS.

GAS ENRICHERS.

JAMES D. PERKINS.

PERKINS & CO.,

F. SEAVERNS.

General Sales Agents for

The Youghioghenny River Coal Company's

OCEAN MINE YOUGHIOGHENY GAS COAL.

The Coal from the Ocean Mine (recently operated by *Messrs. W. L. Scott & Co.*, of Erie, Pa.,) is now used by all the leading Gas Companies in the United States from Maine to Texas, and is recognized as *the only reliable Youghioghenny Gas Coal.* (See Map on p. 87 of this Journal, Feb. 16, '85.)

P. O. Box 3695, New York PERKINS & CO., 228 and 229 N. Y. Produce Exchange. BEAVER STREET ENTRANCE.

BRECKENRIDGE CANNEL, OF KENTUCKY.

This Colliery was re-opened in June, 1886, since which date the Cannel has been delivered to over sixty of the leading Gas Companies in this country and in Europe. As an enricher ONE TON of this Cannel will do the work of TWO TONS of any other available Cannel, and is more economical than Naptha or Oil of any character. It can be delivered in parcels of one car load or more to any point in the United States or Canada.

(See AMERICAN GAS LIGHT JOURNAL, June 16, '86, pp. 346-7.)

P. O. Box 3695, New York PERKINS & CO., 228 and 229 N. Y. Produce Exchange BEAVER STREET ENTRANCE.

JAMES & WILLIAM WOOD, Gas and Cannel Coal Contractors,

No. 40 St. Enoch Sq., Glasgow. No. 2 Talbot Court, London.

Proprietors of the BATHVILLE COLLIERIES (which produce the celebrated BOGHEAD CANNEL), Shields, Shieldmuir, Drumpeller, and other Collieries. This Firm offer

STANDARD CANNELS,

Unequaled as Gas Enrichers.

Analyses, prices, and all further information furnished on application to

Agency for U. S., Room 93, Nos. 2 & 4 Stone St., N.Y. City.

The Standard Oil Company,

REFINERS OF

NAPTHA AND GASOLINES.

ALSO MANUFACTURERS OF

A Special Grade of Naptha for Gas Companies

FOR ENRICHING COAL GAS.

Correspondence solicited.

No. 43 Euclid Avenue, Cleveland, Ohio.

To Gas Companies.

We make to order CAP BURNERS to burn any amo under a stated pressure. Send for samples.

Also, SERVICE CLEANERS, DRIP PUMPS, and STRE MAIN PROVING APPARATUS.

C. A. GEFRORER,

248 N. 8th Street, Phila., Pa.

GOODWIN'S DIRECTORY

OF THE GAS LIGHT COMPANIES of the UNITED STATES & CANADA.

Price, \$3.00.

Orders may be sent to

A. M. CALLENDER & CO., No. 42 Pine Street, N. Y. City.

COKE CRUSHERS.

Newburgh Orrel Coal and Coke Co.

MINERS AND SHIPPERS OF

Mountain Brook Steam and Smithing Coals,
**NEWBURGH, PALATINE,
AURORA & TYRCONNELL
GAS COALS.**

Foundry & Crushed Coke Shipped Direct from Ovens

Mines Situated at

Newburgh, Flemington & Fairmont, W.Va.

HOME OFFICE,

33 S. Gay St., Baltimore.

CHAS. MACKALL, Gen. Mangr.

CHAS. W. HAYS, Agent in New York,

Room 147, WASHINGTON BUILDING, No. 1 Broadway.

Shipping wharves at Locust Point, Baltimore.

THE DESPARD COAL COMPANY

OFFER THEIR SUPERIOR

DESPARD COAL

To Gas Light Companies and Manufacturers of Fire Clay Goods
Throughout the Country.

ROUSSEL & HICKS, } AGENTS. { BANGS & HORTON,
71 Broadway, N. Y. } { 16 Kilby St., Boston.

Mines in Harrison Co., West Va. Wharves, Locust Point, Balt.

Company's Office, 15 German St., Baltimore, Md.

Among the consumers of Despard Coal we name: Manhattan
Gas Light Co., N. Y.; Metropolitan Gas Light Co., N. Y.; Jersey
City, (N. J.) Gas Light Co.; Washington (D. C.) Gas Light Co.;
Portland (Maine) Gas Light Co. Reference to them is requested.

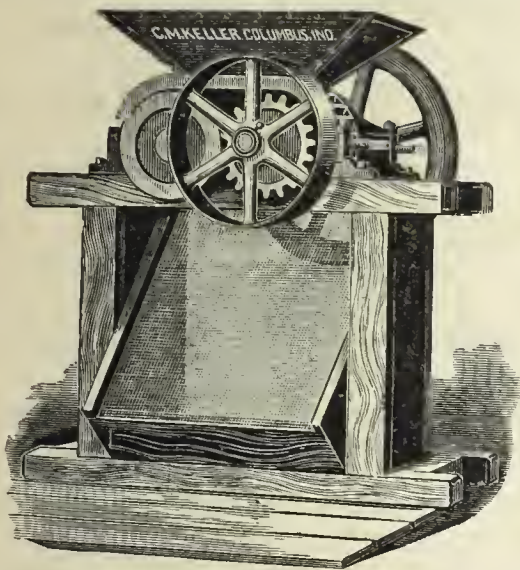

Keller's Adjustable Coke Crusher

SIMPLE, STRONG, AND DURABLE.

C. M. Keller, Sec. & Supt. Gas Lt. & Coke Co. Columbus, Ind.

Correspondence Solicited.

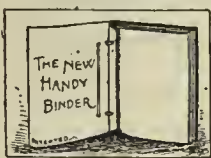

**THE NEW
HANDY BINDER.**

This article may be described as elegant
in appearance, strong, durable, and possessing many special
qualities of its own. It allows the opening of the pages per-
fectly flat, whether one or several numbers are in the hinder
Any number can be taken out and replaced without disturbing
the others. The papers are not mutilated for subsequent hind-
ing in permanent form. The hinder is supplied with gilt side
title, and is an ornament to any desk or reading table. The
JOURNAL, filed in the Handy Binder, becomes a volume of great
value, always convenient for instant reference. Handy Binder,
Postage paid, \$1.00.

A. M. CALLENDER & CO., 42 Pine St., N. Y.

GAS COALS.

GAS COALS.

THE
PENN GAS COAL CO.

OFFER THEIR

Coal, Carefully Screened & Prepared for Gas Purposes.

Their Property is located in the Youghiogheny Coal Basin, near Irwin and Penn Stations on the
Pennsylvania Railroad, and on the Youghiogheny River.

Principal Office:

209 SOUTH THIRD STREET, PHILA., PA.

Points of Shipment:

Pennsylvania Railroad Piers; Greenwich Wharves, Delaware
River; Pier No. 1 (Lower Side), South Amboy, N. J.

Chesapeake & Ohio Railway Coal Agency,

FOR THE SALE OF THE

**Superior Kanawha Gas Coals, Cannelton Cannel,
Also, SPLINT AND STEAM COALS.**

From the Kanawha and New River Regions, on the line of the Chesapeake & Ohio R'way.

C. B. ORCUTT, Sales Agent. | OFFICE, 150 BROADWAY, N. Y.

FRANCIS H. JACKSON, Prest. EDMUND H. MCCULLOUGH, V.-Prest. CHAS. F. GODSHALL, Treas. H. C. ADAMS,

THE WESTMORELAND COAL CO.

Chartered 1854.

Mines situated on the Pennsylvania and the Baltimore
and Ohio Railroads, in Westmoreland County, Penn.

POINTS OF SHIPMENT:

PHILADELPHIA, BALTIMORE, SOUTH AMBOY, N. J.,
WATKINS (SENECA LAKE), N. Y.

Since the commencement of operations by this Company its well-known
Coal has been largely used by the Gas Companies of New England and the
Middle States, and its character is established as having no superior in gas
giving qualities, and in freedom from sulphur and other impurities.

Principal Office, 224 South 3d St., Phila., Pa.

A. M. SCOTT, PRESIDENT.

A. DEMPSTER, C.E., SECRETARY.

W. K. GILLESPIE, TREASURER.

MONONGAHELA AND PETERS CREEK GAS COAL CO.,

PRODUCERS OF

Coal Bluff Gas Coal.

MINES LOCATED ON THE MONONGAHELA DIVISION OF THE PENNSYLVANIA RR.,
IN THE CENTRAL PORTION OF THE PITTSBURGH COAL FIELD.

Points of Shipment—Buffalo, Cleveland, Erie, Chicago, New Orleans.

Since the introduction of Coal Bluff Gas Coal it has taken rank among the few first-class Gas Coals, and ac-
knowledges no superior in gas-giving qualities, ease of working, quality of coke, and freedom from impurities.

General Office, 43 Sixth Ave., Pittsburgh, Pa.

GAS METERS.

GAS METERS.

GAS METERS.



INTERNATIONAL--1876--EXHIBITION.

The U. S. Centennial Commission

HAVE DECREED AN AWARD TO

HARRIS, GRIFFIN & CO.,

Twelfth and Brown Streets, Philadelphia, Pa. No. 49 Dey Street, N. Y. City, and No. 75 North Clinton Street, Chicago, Ill.

FOR THE FOLLOWING REASONS:

The Exhibit consists of a Series of METERS from the Largest Size Station Meters for the use of the MANUFACTURE OF GAS, to those for the use of the ORDINARY CONSUMER. The Instruments are WELL MADE, RELIABLE as to INDICATION, and embody a number of sundry improvements which, with the general character of the Exhibit, entitle the whole to commendation.

Attest—J. L. CAMPBELL,
Secretary, pro-tem.

Signed—A. T. GOSHORN,
Director General

J. B. HAWLEY,
President

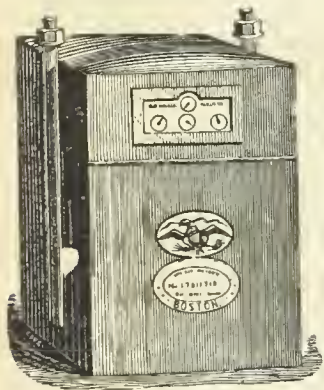

Dry Gas Meter.

With 39 years' experience and the best facilities for manufacturing, is enabled to furnish reliable work and answer orders promptly.

NATHANIEL TUFTS,

No. 153 Franklin Street, Boston, Mass.,

MANUFACTURER OF

DRY GAS METERS.

Station Meters of any Capacity.

Test and Experimental Meters, Pressure Registers, Pressure Gauges, Pressure and Vacuum Gauges.

METER PROVERS, PHOTOMETERS, STREET LANTERNS, ETC., ETC.

Patent Cluster Lanterns for Street Illumination.

SCIENTIFIC BOOKS.

We are prepared to furnish to Gas Managers, and others interested in the topics treated of, the following books, at prices named:

KING'S TREATISE ON THE MANUFACTURE OF COAL GAS. Three vols.; \$10 per vol.	PRACTICAL TREATISE ON HEAT, by THOMAS BOX. Second edition. \$5.	THE GAS MANAGER IN THE LABORATORY, by a Practica Student. 8vo., Cloth. \$1.50.
GAS MANUFACTURE, by WILLIAM RICHARDS. 4to., with numerous Engravings and Plates, in Cloth binding. \$12.	GAS WORKS—THEIR ARRANGEMENT, CONSTRUCTION, PLANT, AND MACHINERY. \$8.	THE DOMESTIC USES OF COAL GAS, AS APPLIED TO LIGHTING, by W. SUGG. \$1.40.
THE GAS ANALYST'S MANUAL, by F. W. HARTLEY. \$2.50.	COAL; ITS HISTORY AND USE, by PROF. THORPE. \$3.50.	DISTILLATION OF COAL TAR AND AMMONIACAL LIQUOR by GEO. LUNGE. New Edition. \$12.50.
TECHNICAL GAS ANALYSIS. \$2.80.	THE GAS WORKS OF LONDON, by COLBURN. 60 cents.	A TREATISE ON THE COMPARATIVE COMMERCIAL VALUES OF GAS COALS AND CANNELS, by D. A. GRAHAM 8vo., Cloth. \$3.
GAS MANAGER'S HANDBOOK, by THOS. NEWBIGGING. \$4.80.	THE GAS FITTER'S GUIDE, Showing the Principles and Practice of Lighting with Coal Gas, by JOHN ELDREDGE. 40 cents.	GAS AS A SOURCE OF LIGHT, HEAT, AND POWER, by C. J. R. HUMPHREYS. 10 cents.
GAS CONSUMER'S GUIDE. \$1.	GAS WORKS, AND MANUFACTURING COAL GAS, HUGHES. \$2.20.	GAS COMPANIES DIRECTORY. \$3.
A GUIDE TO GAS LIGHTING. 40 cents.	THE MANAGEMENT OF SMALL GAS WORKS, by C. J. R. HUMPHREYS. \$1.	GAS VERSUS ELECTRIC LIGHT. 50 cents.
GAS MEASUREMENT AND GAS METER TESTING, by F. W. HARTLEY. \$1.60	MANUAL FOR GAS ENGINEERING STUDENTS, by D. LEE, 40 cents.	PURIFICATION OF COAL GAS, by R. P. SPICE. 8vo. \$3.
GAS CONSUMER'S HANDBOOK, by WILLIAM RICHARDS, C.E.; 18mo., Sewed. 20 cents.	HOW TO MANAGE GAS, by F. WILKINS. Paper. 20 cents.	
A PRACTICAL TREATISE ON GAS AND VENTILATION with Special Relation to Illuminating, Heating, and Cooking by Gas, by E. E. PERKINS. \$1.25.		

The above will be forwarded by express, upon receipt of price. We take especial pains in securing and forwarding any other Works that may be desired, upon receipt of order. All remittances should be made by check, draft, or post office money order.

A. M. CALLENDER & CO., No. 42 Pine Street, New York.

KING'S TREATISE ON COAL GAS.

The most complete work on Coal Gas ever published. Three vols., bound \$30.

A. M. CALLENDER & CO., No. 42 Pine Street, New York.

GAS METERS.

GAS METERS.

GAS METERS.

GEO. J. MCGOURKEY, Pres. WM. H. MCFADDEN, Vice-Pres. (Phila.). WM. N. MILSTED, Gen. Supt. & Treas. (New York). WM. H. DOWN Sec.

AMERICAN METER COMPANY.

WET AND DRY GAS METERS.

PRESSURE REGISTERS.

METER PROVERS.

STATION METERS.

PRESSURE & VACUUM REGISTERS.

PORTABLE TEST METERS.

EXHAUSTER GOVERNORS.

PRESSURE & VACUUM GAUGES.

EXPERIMENTAL METERS.

DRY CENTRE VALVES.

CRESSON GAS REGULATORS.

AMMONIA TEST METERS.

GOVERNORS FOR GAS WORKS.

MARSLAND WATER METERS.

BAR AND JET PHOTOMETERS.

Manufactories:

512 W. 22d St., N. Y.
Arch & 22d Sts., Phila.

GAS STOVES,

SUGG'S "STANDARD" ARGAND BURNERS,
SUGG'S ILLUMINATING POWER METER,
Wet Meters, with Lizar's "Invariable Measuring" Drum.

Agencies:

177 Elm Street, Cincinnati.
244 & 246 N. Wells Street, Chicago.
810 North Second Street, St. Louis.
222 Sutter St., San Francisco.

HELME & McILHENNY,

(Successors to Harris & Brother. Established 1848.)

GAS METER MANUFACTURERS,

CONTINUE AS HERETOFORE AT THE OLD ESTABLISHMENT,

Nos. 1339 to 1349 Cherry Street, Philadelphia, Pa.,

To Manufacture Wet and Dry Gas Meters, Station Meters, Experimental Meters, Meter Provers, Center Seals, Pressure Registers
GOVERNORS, INDICATORS, PHOTOMETERS, & ALL OTHER KINDS OF APPARATUS FOR USE IN GAS WORKS.

From our long practical experience of the business, and from our personal supervision of all work, we can guarantee all orders to be executed promptly and in every respect satisfactorily.

WM. WALLACE GOODWIN, Prest. and Treas.

WM. H. MERRICK, V.-Prest.

S. L. JONES, Sec.

S. V. MERRICK, Supt.

THE GOODWIN GAS STOVE AND METER COMPANY,

Successors to W. W. GOODWIN & CO.

1012, 1014 and 1016 Filbert St., Phila., Pa. 142 Chambers St., New York.
76 Dearborn St., Chicago, Ill.

WALDO BROS., Agents, 88 Water St., Boston.

MANUFACTURERS OF THE "SUN DIAL" GAS STOVES, FOR COOKING AND HEATING PURPOSES.

Dry and Wet GAS METERS, Station Meters (Square, Cylindrical, or in Staves) Glazed Meters, King's and Sugg's Experimental Meters, Lamp Post Meters, Etc., Etc., Meter Provers (sizes 2, 5 and 10 feet), Pressure Guages of all kinds, Pressure Registers, Pressure and Vacuum Registers, Pressure Indicators (sizes 4 inch, 6 inch and 9 inch), King's Pressure and Vacuum Gauges, Dry and Wet Centre Seals, Dry and Wet Governors, Exhauster Governors, Photometers of all descriptions. Lethby's Sulphur and Ammonia Test Apparatus complete—also Testing and Chemical Apparatus of all kinds, and of the most perfect description, for all purposes relating to Gas.

GOODWIN'S IMPROVED LOWE'S JET PHOTOMETER.

Agents for Bray's Patent Gas Burners and Lanterns.

Special attention to repairs of Meters, and all apparatus connected with the business.
All work guaranteed first class in every particular, and orders filled promptly.

G. B. EDWARDS, Mang'r, New York.
E. H. B. TWINING, Mang'r, Chicago.
Represented by S. S. STRATTON.

D. McDONALD & CO.,

GAS METER MANUFACTURERS.

(Established 1854.)

51 Lancaster St., Albany, N. Y. 34 & 36 West Monroe St., Chicago, Ill.

STATION METERS, EXPERIMENTAL METERS, METER PROVERS, PRESSURE & VACUUM REGISTERS, PRESSURE GAUGES, ETC.

Also STAR GAS STOVES, RANGES, and HEATING STOVES.

We use only the very best materials, and employ the most skilled labor, and by our long experience (32 years) and personal supervision of every detail, we feel justified in assuring the public that our goods will give perfect satisfaction. Every Meter emanating from our establishment will bear the State Inspector's BADGE, and will be fully warranted by us. Our Annual and Calendar will be sent to Gas Companies upon application.

GAS STOVES.

GAS STOVES.

GAS STOVES.

THE GOODWIN GAS STOVE AND METER CO.,

1012-18 Filbert St., Phila., 142 Chambers St., N. Y., 76 Dearborn St., Chicago.

Agents, WALDO BROTHERS, 88 Water Street, Boston.

WM. W. GOODWIN, PRES. & TREAS.
W. H. MERRICK, VICE-PRES.
S. LEWIS JONES, SEC.
SAMUEL V. MERRICK, SUPT.

SOLE MANUFACTURERS OF THE

G. B. EDWARDS, Mang'r, N. Y.
E. H. B. TWINING, Mang'r, Chicago.
Represented by S. S. STRATTON.

"SUN DIAL" GAS STOVES

The Most Economical, Efficient, and Durable Gas Stove Made.

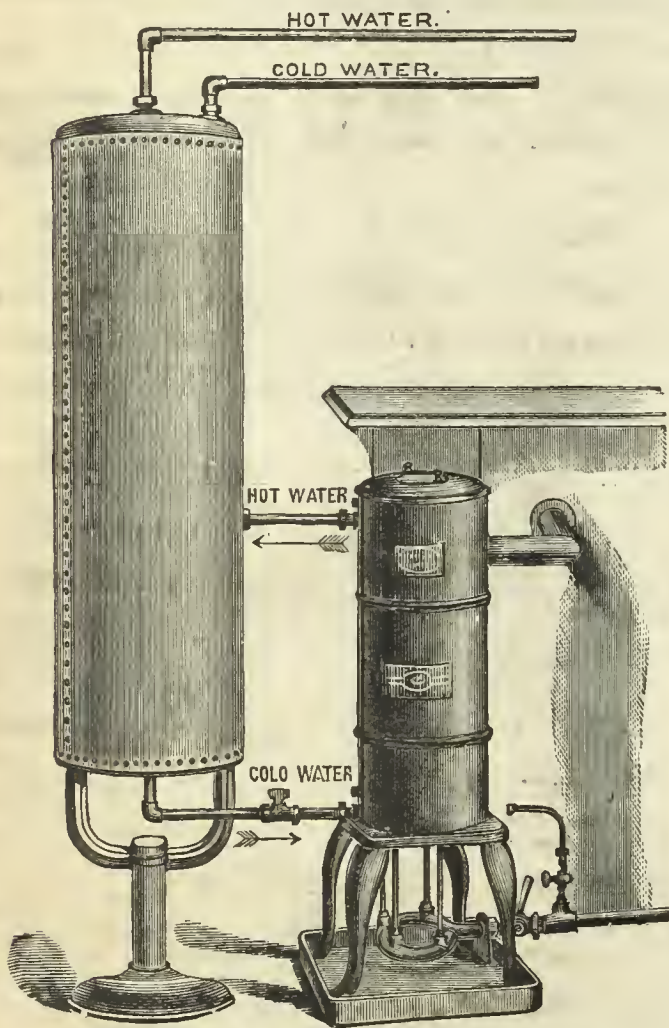

I.—Safety Hot Water Generator and Boiler.

Safety Hot Water Generator and Boiler.

Cut I. represents our Safety Gas Hot Water Generator and Boiler, arranged for home use. This most easy, quick, and economical way of preparing a warm bath, or for heating water for any domestic purpose, entirely supersedes any necessity for the use of ranges or stoves—a great comfort, particularly in hot weather. The boiler being self-filling, as the hot water is drawn off, can never become empty, thus preventing the possibility of any accident.

We beg to call attention to the cast iron pan which is now attached to the legs of the Generator (see illustration). This is to catch the drippings from the Coil, which many persons suppose come from a leak, when in fact they are produced by condensation. This condensation caused by the hot flame coming in contact with the coil filled with cold water.

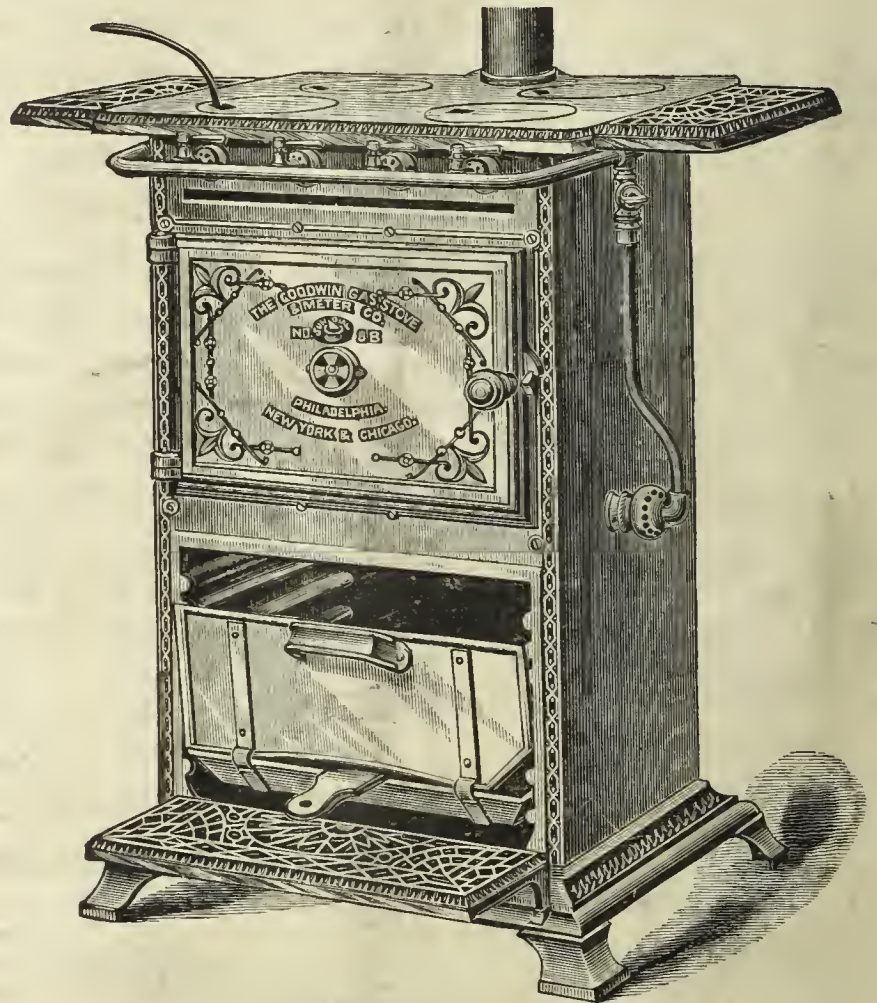

II.—Gas Cooking Stove No. 8 B.

New Style Gas Cooking Stove.

Cut II. represents our New Style Cooking Stove. As will be seen, it has an ornamented cast iron base and front, and extension shelves. The oven burner, which is atmospheric (unless otherwise ordered), is of an entirely new and improved pattern (patent applied for). The ovens are of greater capacity than those of the old style. The top, in conjunction with the outlet pipe, is designed to carry off all products of combustion; hence the outlet pipe must be connected with a flue, or the stove will not work properly.

This Stove has 4 boiling burners in top of hot plate. All fittings are nickel plated. We making this style of Cooking Stove in the following sizes—viz., No. 7 B, No. 8 B, No. 9 B, No. 10 B.



III.—Improved Hot Plate, No. 108.

New Style Hot Plates.

Cut III. represents our New Style of Hot Plates, of which we are making No. 106 (two small boiling burners), No. 107 (two medium sized boiling burners), and No. 108 (two medium and one large boiling burner). See new Catalogue and Price List for further particulars.

THE AMERICAN

GAS LIGHT JOURNAL

PUBLISHING OFFICE No. 42 PINE STREET

DEVOTED TO THE INTERESTS OF ILLUMINATION, VENTILATION, WATER SUPPLY AND DISTRIBUTION, & GENERAL SCIENCE.

VOLUME XLVII.—No. 10.
Whole No. 682.

NEW YORK, WEDNESDAY, NOVEMBER 16, 1887.

{ \$3 PER ANNUM.
IN ADVANCE.

A. M. CALLENDER & CO., Proprietors. C. E. SANDEBSON, Manager.
JOS. R. THOMAS, C.E., Editor. T. J. CUNNINGHAM, Asst. Editor.

ENTERED AT THE POST OFFICE AT NEW YORK, N. Y.
AS SECOND CLASS MATTER.

CONTENTS.

An Asterisk (*) denotes an illustrated article.

EDITORIALS—

The Nettleton and King Papers.....	365
Books Received.....	306
Shall Chicago have a Municipal Gas Works?.....	306
Trenching and Pipe Laying.....	306

ITEMS OF INTEREST FROM VARIOUS LOCALITIES..... 307

New York Sends Fireclay Material to British Columbia—Annual Election—Will it be Upset?—Will Lancaster (Pa.) Have a Municipal Lighting Station?—All over the State—Increasing the Capital Stock—Rome (Ga.) to Try the Combination Idea—Gas Turned on—Proposals for Street Lighting, Cleveland, Ohio—A Novel Suit—Some Changes in West Troy's Gas Supply—Can this Account for Some of Henry George's Queer Talk?—In Charge at Aurora, Ill.—The Men at the Helm—A Change Proposed at Wheeling, West Va.—Annual Meeting, Waukesha, Wis.—Bids for Public Lighting, Conshohocken, Pa.—New Lighting Company—Combining at Galveston, Tex.—New Electric Light Company—A Gas Machine will Furnish the Gas—A Bit of Baltimore (Md.) Gossip—Reversing the Decision—Result of a Suit for Damages—About Completed—One Thing that was Witnessed—A Hint from Manchester, N. H.—What is the Matter with the Proprietors?—Quite a Good Showing—Progress Made on the Vancouver (Brit. Col.) Gas Works—Chartered—The Gasoline Stove—Going Lower in London, England—Public Lighting at Portland, Me.—They Want Gas—Heard from Once More—The Cost—An "Approved" Electric Lamp Post—Police-men do not Want to Act as Lamplighters—Where They Can be Seen in this Vicinity—Destroyed—To Hone the Plant—Tumbled Down—Is There Room for Them?—Public Lighting, Utica, N. Y.

Fifteenth Annual Meeting American Gas Light Association—Official Report—Concluded from page 281..... 311

Second Day, Morning Session—Fuel Gas, by Emerson McMullin—Discussion—Report of Special Committee on a Uniform Standard of Meter Connections—The Advantages of Gas Companies Engaging in the Electric Light Business, by E. J. King—Discussion—Afternoon Session—Committee of Arrangements for Toronto Meeting—The Comparative Illuminating Power of Gas Purified with Lime vs. Oxide of Iron,* by C. W. Blodget—Three Purification Puzzles, by Thos. Turner—Joint Discussion—Disadvantages Occasioned by Fluctuations of Candle Power in Gas Furnished to Consumers, by Richard J. Monks—Development of the Half-Depth Regenerative Furnace, and Some of the Results, by O. B. Weber—The Advantages of Regenerative Furnaces for Large and Small Gas Works, by F. Bredel—Joint Discussion—The Use and Value of Coke for Generating Steam, by J. L. Hallett—Discussion—Appointing the Committee of Investigation—Supplementary Reports from Executive Committee—Publishing the Proceedings—The Toronto Meeting—Printing the Papers in Advance—Mr. Splice on the Gas Interest in England—Back Again to the Publication of Proceedings—Votes of Thanks—Vote of Sympathy.

The Valuation of Oxide of Iron for the Purification of Gas.....	331
Saccharin.....	332
Difficult Soldering.....	332
Distillation of Wood.....	333
Combustion.....	333
The Indian Petroleum Fields.....	333
The Market for Gas Securities.....	334
* The Crompton Shadowless Arc Light Pole.....	334
A Line from Marlboro', Mass.....	334

THE NETTLETON AND KING PAPERS.

Perhaps the truth will have been told were we to say that the papers read by Messrs. Nettleton and King at the late meeting of the American Association will receive a greater share of close attention than that devoted to any other of the literary contributions, excellent as the latter were in every respect. The reason for that greater interest is not hard to find, and lies in the fact that the papers treated, respectively, on subjects which, although diverse enough in the main, appeal to the gas maker with great directness and force. Perhaps the last clause might be modified to the extent of saying that Mr. Nettleton's statements will impress themselves deeper in the minds of those who make coal gas than in the case of those who favor the evolution of water gas; but a like qualifica-

tion need not be put forward in respect to the subject discussed by Mr. King. Here we meet on common ground, or where all ought to be, and no doubt are, equally interested and anxious to serve one another in the attempt to solve properly a problem which, while it no longer threatens disaster, even yet is a thorn in the flesh of those operating gas plants in many localities.

Returning now to Mr. Nettleton's paper on the "Utilization of Residual Products," we must, at the outset, disagree with the member from Birmingham, Conn., about what he terms an unfortunate selection on the part of the Committee in allotting to him the task of preparing a paper. His fellow members no doubt will agree with us in such dissent, for how can it be otherwise when the lines subsequently submitted by the one selected by the Committee prove the reverse of what their author asserted. Indeed, his paper furnishes the best evidence permissible that the Committee knew their man. We, of course, must concede that, in another and widely different sense—with respect to the press of business in which the Committee's mandate found their victim involved—the designation was unfortunate; but, therefore, all the more praise must be awarded him for his prompt response; and his readiness to serve his fellows, at considerable personal trouble, too, may hereafter nerve some weak brother to follow in similar lines when the call to duty sounds his way.

Unfortunately the American gas maker is altogether too unfamiliar with the European gas works example instanced, in which the entire cost of manufacture was paid for by the receipts from residual products. Still more unfortunate, however, is he from being painfully conversant, if not intimate, with the reverse side of the example—that in which the tar is seen passing away in the waters of some convenient stream, and where nearly all of the coke produced is burned up in the fires of the furnaces. But there is no reason for the existence of the latter state of affairs, since it is simply the inevitable result of indifference, ignorance, or inanity—three very poor staffs, the last being, if not the most excusable, at least worthy of passing pity. However, while life lasts hope exists; and it is with gratification we can say that the dismal parallel becomes less frequent every year. Furthermore, the ratio of rapidity of its extinction increases with the lapse of time, and hence we venture to look forward hopefully in the assurance that at no distant day the rivers will cease, and finally, to act as tar wells, and that the greed of the furnaces will be the easier appeased.

Mr. Nettleton, than whom no more careful and painstaking practical worker in the American gas field have we knowledge of, places this matter of the utilization of residual products before us in such manner as to convince the most skeptical that the avenue leading to "dollar gas" commences at "residual hill." No one will claim for it the virtue, or rather the allurements, of being a broad and easy thoroughfare; on the contrary, it is steep and rugged. But it is a royal road, after all, and one that does lead on to fortune. What has been accomplished by Mr. Nettleton at Birmingham can be accomplished elsewhere—in part, at least—by adopting the policy that developed his success. Perseverance and judgment based on such lines must win the day; and we take this occasion to congratulate Mr. N. on the way in which his labors in the residual field have been rewarded.

Mr. King's paper, although perhaps not dealing with the subject (the

supply of electric light by gas companies) in the manner anticipated, nevertheless leaves no room for doubt as to his own personal opinion on the question. We incline to the belief that many of the delegates expected some close statistics regarding the actual cost, etc., of the operation of the Jacksonville (Ills.) Gas Company's electric light supply annex; but no doubt the wish was father to the thought. Strictly speaking, while the expectation might have been rife, its fulfillment would possibly be a trifle exacting on Mr. King. But in any event the curious can extract solace from the knowledge that if his verdict were not based on facts and figures of an entirely reliable sort, his summing up would have been pitched in a different key. The discussion on Mr. King's paper, however, supplied some of the items not mentioned specifically by him; and it is beyond disproof that the tenor of the debate sustained Mr. King's position on the question at issue. While admitting that the advocates of dual supply seemed to have the best of the argument, we are nevertheless disposed to attach great weight to the objections so forcibly put forth by Mr. Pearson, of Toronto. The fraternity, however, may rest assured that the day is not far distant when this entire matter will emerge, for good-and-all, from the slightest shadow of doubt.

BOOKS RECEIVED.

We are indebted to the courtesy of Mr. W. H. Bennett, Secretary of the British Gas Institute, for a bound copy of the "Transactions" for 1887. As usual, the volume is well edited, and printed from good, clear type. The illustrations to the papers are copious and well drawn. In addition to the report of the proceedings, the volume contains a list of the names of those on the rolls of the Society, a statement of its finances, the rules of government, a full description of the method of maintaining the benevolent fund, and other matter of general interest. We note that the price charged for delivering a copy of the "Transactions," post free to any address in the Postal Union, is 11 shillings, British.

A copy of the eleventh issue (1887) of "Hastings Directory of Gas and Water Companies Throughout the United Kingdom" is to hand. This valuable gazette now contains a perfect list of the English Companies, and important statistics concerning them as well. We note that this year Mr. Hastings has attempted, under the head of "Continental," to supply information regarding gas works enterprises in this country. Candor, however, compels the admission that the statistics given are of doubtful value, chiefly because of their incompleteness.

We are in receipt of a copy of Mr. John Allan's "Analyses of the Accounts of English Gas Companies and Corporations"—the compiler, by the way, edits the *Gas World*. The accounts of 29 companies, including some of the largest in the Kingdom, are analyzed in minute and masterly fashion.

Still another English printed visitor is "A Manual of the Manufacture of Gas from Tar, Oil, and other Liquid Hydrocarbons, and Extracting Oil from Sewage Sludge," from the pen of Mr. Wm. Burns, C.E. The treatise is mainly devoted to a description of the author's plans and processes for the accomplishment of the objects set forth. It has a "preface" and an "introduction," both being chiefly devoted to an ill-considered attack on the London *Journal of Gas Lighting*, whose editors, it appears, did not view Mr. Burns' efforts in the line of gas making indorsed or put forth by him as being particularly well qualified to receive their approval. We think Mr. Burns' book would have greater value were the "preface" and "introduction" written in a different strain. Messrs. E. & F. N. Spon are the publishers.

Next we have a copy of the "Report of the Proceedings of the Seventh Annual Meeting of the American Water Works Association," which was held last July at Minneapolis, Minn. Judging from the matter contained in this volume, the Minneapolis session must have been well worth attending. We congratulate Secretary Decker on his editorial capacity, for the report is complete in every respect; and we thank him for his courtesy in mailing us a copy of it. The Standard Printing Company, of Hannibal, Mo., are the publishers.

Shall Chicago have a Municipal Gas Works?

The following ordinance was introduced by Ald. Gile at a recent session of the Chicago City Council:

"Be it ordained by the City Council of the city of Chicago:

"SEC. 1. There is hereby created a Board of Commissioners of Gas of the city of Chicago.

"SEC. 2. Said Commissioners shall consist of three competent and capable persons, one of whom shall be designated to act as President, one as Secretary, and one as Treasurer.

"SEC. 3. The Mayor shall have the power of appointment and removal, and shall also designate who shall act as Secretary and Treasurer of said Board.

"SEC. 4. The Commissioners when appointed shall be required to give a good and sufficient bond, the amount to be determined by the Mayor, Comptroller and Chairman of the Finance Committee, for the faithful performance of the duties of their office.

"SEC. 5. The salary of the President of the Board of Commissioners shall be \$5,000 per annum; of the Secretary, \$2,500, and the Treasurer, \$2,500.

"SEC. 6. The duties of the Commissioners shall be to construct, maintain and operate gas works, such works to be known as the Chicago City Gas Works, within the city of Chicago, and they shall have the right upon and under all the avenues, streets, alleys and public places in said city for the purpose of placing, operating, repairing and maintaining one or more lines of gas mains and pipes, and all necessary feeders and service pipes in connection therewith, for lighting and fuel purposes.

"SEC. 7. Said Commissioners shall be under the control and direction of the Commissioner of Public Works, as to use and repair of the streets of the city, and subject to all regulations and ordinances concerning the same.

"SEC. 8. The city of Chicago shall not be held liable for the payment of principal or interest on any bonds that may be issued by said Commissioners for the purpose of erecting gas works or maintaining them.

"SEC. 9. The Mayor, Comptroller and the chairman of the Finance Committee shall from time to time, and as often as once in each month, carefully examine into the management and affairs of said Commissioners of Gas, and said Commissioners shall as often as once in each month submit a written statement of the condition of the works under their charge and all matters pertaining thereto.

"SEC. 10. The Council may from time to time appropriate funds toward the erection and maintenance of such works. For such appropriation the Comptroller shall receive bonds signed by the President and Treasurer of the Gas Commission. Such bonds shall draw interest at the rate of 5 per cent. per annum, and shall be a lien on the gas works of said city of Chicago, but such bonds shall have no prior claim over other bonds issued by the said Commissioners for the same purpose.

"SEC. 11. The Council may determine the price charged to consumers for gas, which price shall be determined from time to time by the actual cost of production, after providing for the liabilities of the gas works, for interest and expenses, and a sum to be set apart as a sinking fund for retirement of the bonds and extension of the works; provided, that the maximum price charged shall not exceed \$1 per thousand feet for gas.

"SEC. 12. This ordinance shall take effect and be in force from and after March 1, 1888."

Referred to Committee on Gas.

Trenching and Pipe Laying.

[Abstracted from a paper (by Wm. R. Billings, C.E., on "Some Details of Water Works Construction,") contributed to the *Engineering and Building Record*.]

A trench which is troublesome on account of caving grows worse the longer it is open; if, then, the trenching gang is a good distance ahead of the pipe layers, and water and quicksand are found within two or three feet of the surface, it is wise to send the diggers ahead on to dry ground, or make some other arrangement, so that the last two or three feet in depth of the wet trench will not be opened until pipe can be dropped into it. When caving occurs in wet, heavy ground some warning of the impending trouble is given by cracks in the surface, running nearly parallel to the side of the trench; but in sandy gravel the drop comes without warning, and men may be seriously injured. In any case the tendency to caving is increased by the weight of the excavated material piled up on one edge of the trench; and if circumstances will permit, it is well to keep men on the bank to shovel back the material as fast as it is thrown out.

In soil that will allow it, tunneling will often save the public and individuals much inconvenience by carrying the trench under crosswalks, driveways, and railroad crossings, and the only tools needed are the tunneling bars mentioned in the list of tools, and long-handled shovels. A little practice and boldness in this detail will give very satisfactory results.

In these cases bell-hole digging and joint making must be done together, and some suggestions upon this detail will be given later.

With cast iron pipe, when the digging is good and the trench stands up well, it pays to put three, four, or half a dozen men at work digging bell-holes—that is, enlarged places in the trench, spaced so as to come about the joints of the pipe, and large enough to give a man room to swing his hammer and get at all parts of the joint without unnecessary fatigue. There is little or no danger of getting the bell-holes too large, and plenty of room for the calker will do not a little toward insuring tight and strong work. The bottom of the trench should be dug out 8 or 10 inches for a length of 4 feet beyond the joint, and the sides worked out on the same scale to give ample shoulder room. These directions will have a queer sound when one is trying to make joints in quicksand, and at such a time fixed rules amount to but little. No end of grit, plenty of hard work, with some little planning, will make joints in places that seem all but hopeless for the first half-hour.

Neither stony nor rocky trenches offer any serious difficulties, and even in ledge-work it is simply a question of time and money. If the bottom of the trench comes in rock which must be worked out by drilling and blasting, the ledge should be cut away to a depth which will allow sand 6 or 8 inches in depth to be spread upon the rock, in which the pipe may be imbedded. If boulders are encountered which are too large to be taken out by the derrick, they should be well cleared from the confining earth by digging before applying powder or dynamite; this gives the explosive a fair chance, and digging is cheaper than drilling and blasting. Large pieces may sometimes be worked off from a boulder or ledge which projects into the trench, without using explosives, by means of small hand-drills and "feathers and wedges." To do this drill $\frac{3}{4}$ -inch holes with a short steel drill and stonemason's hand-hammer along the desired line of fracture, 8 or 10 inches deep and 6 inches apart; drop a pair of feathers made of $\frac{3}{4}$ -inch half round iron into each hole, and drive the wedges between each pair.

In blasting, the nitro-glycerine preparation known to the trade as "forcite powder" is comparatively safe, and gives better results than common gunpowder, for it will shatter rocks more thoroughly and with less tamping. To fire a $1\frac{1}{2}$ -inch hole 3 feet or more in depth, take a whole forcite cartridge, cut off perhaps half an inch in length, and set a percussion cap pinched on to the end of a piece of fuse into this short piece of the forcite by boring out a small hole with a knife. Lower this into the whole, and cover it with the remainder of the cartridge broken into small pieces between the fingers, and fill up the hole with earth tamped down with a stick.

Such a charge as that will let daylight into any rock that a pipe gang is likely to encounter, but the blast should be carefully loaded with logs, timbers, or railroad ties chained together, and covered with brush to arrest small pieces which may do damage if allowed to fly away. This forcite powder may be used to loosen a troublesome boulder, by simply poking a hole into the bank alongside of it, and tucking in a little of the explosive folded in an envelope and held in place by a slight packing of earth; or a cracked and seamy rock may be thoroughly split by dropping an envelope full of the powder into one of the cracks, and firing by cap and fuse in the usual manner.

Rocks which appear in the bottom of a wet trench are unwelcome enough, but it will not do to leave them in such shape that a pipe will be supported by them in the middle with the weight of the back-filled earth bearing on the ends lying in soft ground. If the expense of getting out the rock seems too great, the depth of the trench should be reduced until a firm and even bearing can be secured.

On all trenches that do not stand up well, or that must be made wide to get out rocks, a long three-legged derrick will be found exceedingly convenient, for its range is wide, and it can straddle fences in a right handy fashion.

Pipe-Laying.—When 100 feet of trench has been bottomed out it is time to make up the derrick gang, and begin the work of putting the pipe into the ground. For 6, 8, or 10 inch pipe six men are enough, and they should be strong, active, and intelligent laborers. Men who are employed in this gang generally expect, perhaps, 25 cents per day more than the average digger, and good men in the place are worth it. It is not well to let the fellows who may be first chosen for this gang think that they are indispensable, and if one of them happens to be off a day, do not hesitate to take any good man out of the trench to fill the vacant place.

The first thing that a green lot of men must learn is to raise and carry the derrick, assuming that it is to be of the three-legged style referred to in a previous chapter. It is to be raised, first, just as a ladder should be, by footing the bottom and walking it into an upright position; then let one man grasp the pin on the middle leg with one hand and the leg with the other, a man at each of the other legs holding them firmly, and carry it straight away 5 or 6 feet; spread the other two legs the same distance, and the derrick stands alone, though perhaps not very firmly. A little study of the structure will now show that the legs may be spread as far apart as need be, provided always that lines joining the feet of the derrick form either an isosceles or an equilateral triangle, the line joining the two outside legs being the base. In placing over the trench, the middle leg should stand on the side which has the largest quantity of earth upon it. The man carrying the third leg, as the derrick is moved along from pipe to pipe, should grasp the pin firmly when the time for moving comes, throw his weight toward the trench, and be careful to keep midway between his comrades who are carrying the outside legs, and they in turn should walk as close to the edge of the trench as practicable, resist the push of the derrick firmly, and keep about 10 feet apart.

A man at each leg, another to carry the rope, and two men in the trench, make an ordinary derrick gang; for handling 16-inch pipe more

men will be needed in hoisting and placing. The smaller sizes of pipe can be brought from the side of the road to the trench by means of the carrying sticks. These sticks thrust into a pipe give good lifting hold, and two stout fellows at each end, shoulder to shoulder, will carry 4-inch easily, and 8-inch without overwork. Skids of 4x4 spruce thrown across the trench may support the pipe while the derrick is put in place over it; a sling of rope is then to be passed around the pipe enough nearer to the bell than to the spigot end to cause the spigot end to fall easily into the trench when the pipe is lifted by the tackle from the skids. As the skids are removed to allow the pipe to be lowered into the trench, let one of the men bunt the pipe with the end of the skid to clear the pipe from sticks, stones, and dirt. This is not enough, however, and it should be the duty of the men in the trench to look through the pipe as it comes down to them, and make sure that no one has either maliciously or carelessly left therein an old hat, or a pair of boots or overalls. These remarks are not in jest, for just such combinations of what the doctors might call incompatibles have been made.

As the pipe is lowered one of the trenchmen enters the spigot into the preceding bell, his comrade assisting as best he can; but before the pipe rests on the ground it is well to swing it in like a ram against the pipe already laid, to make sure that the joints ready for calking are all "home." As soon as the pipe rests on the bottom the foreman should straddle the trench at a convenient point ahead of the derrick, align the pipe just laid, and look back over the line for joints which may be improved.

The trenchmen should carry bars with them to throw the pipe, and not try to use shovels for levers. Attention should be given to vertical alignment, as well as horizontal, and if grades are not given by an engineer, and no use is made of a carpenter's level on the pipes, the vertical alignment may be kept within bounds by keeping the joints of the same width at the bottom as at the top. If the bell end of a pipe when it rests on bottom is found to be too low, raise it with the derrick, throw rather more than enough loose dirt under it, and then drop the pipe down hard on this two or three times. As soon as the pipe is in position a few shovelfuls of earth should be thrown on to the center of it to hold it, and if the trench is bad, the section between the joints may be half filled at once, as this will support the bank and counteract any tendency to caving. With 4 and 6-inch pipe and a troublesome trench, two or three lengths may be put together on the bank, the joints made on dry land, and then with two derricks and careful slinging three lengths may be put into the trench at once without straining the joints. The few joints that must be made in the trench may, in quicksand, seem at first like hopeless cases, but persistence and no thought of ultimate failure have conquered the most cases that have come in the experience of the writer. In such instances it is useless to attempt to get the sand down so as to make the joint right through without stopping to dig out again. Let the calker stand on the pipe while a good man with a shovel, perhaps a lot of sod, and some pieces of plank, clears away and holds back the stuff so that the joint may be yarned if not poured. If the sand rises as the shoveling ceases, let the calker do all he can by quick work, and then rest, while another attempt with planks, sod, pails and shovels, is made to make room for him. In general, whatever means are employed to make and maintain room for joint making in quicksand, let the preparations be thorough: let the plank be driven as deep as possible and well braced, sods provided in large quantities; have pails or a good ditch pump, and good strong men who are not afraid to "pitch in."

In order to locate gates or special castings in a particular spot, or to bring a joint into a more accessible location it is frequently necessary to cut pipe.

For this use an 8 to 10-pound sledge, and a long-handled cutting-off tool; put a skid under each end of the pipe, placing one directly under the line of cutting, and get a firm and even bearing on the ground for its whole length. A line for the cutter to follow may be had by winding the end of a tape line about the pipe, and marking along the edge with chalk, but a little practice will enable one to guide the cutter as the pipe is slowly rolled on the skids, so as to make a square cut. The blows of the sledge should be rather light for the first time around, and then when the cut is well marked so that it may be easily followed, the blows may be swung in with vigor.

The pipe should at some stage of the work be carefully inspected for cracks, which are oftenest found at the spigot end. If a crack in a spigot end is very slight and so short as to be more than covered by the bell, we may not think it worth while to cut the pipe; but a long crack obliges us to waste nearly twice its length of pipe, for the cut must be made at least 6 or 8 inches above the visible end of the crack, and even then the jar of cutting may cause the crack to run still farther into the sound metal.

ITEMS OF INTEREST FROM VARIOUS LOCALITIES.

NEW YORK SENDS FIRECLAY MATERIAL TO BRITISH COLUMBIA.—We are, through the courtesy of Mr. Adam Weber, of No. 633 East 15th street, this city, enabled to say that the first shipment of firebrick material ever sent from this country to British Columbia was made by him on the 28th of last month. On that date Mr. Weber forwarded, *via* the N. Y. O. and W. and the Canadian Pacific Railways, four cars containing clay retorts and settings, complete, for two benches of 6's to be constructed on the Weber half depth regenerative furnace plan at the works of the Victoria Gas Company.

ANNUAL ELECTION.—The annual meeting of stockholders in the Narragansett Electric Lighting Company was held at No. 52 Aborn street, Providence, R. I., on Oct. 28. The following were elected: Directors: H. E. Wellman, I. M. Potter, J. M. Ripley, F. H. Peckham, Jr., S. C. Blodget, Jr., M. H. Hartwell and M. J. Perry. At the organization session, held Nov. 3, the following officers were chosen: President, H. E. Wellman; Vice-President and General Manager, M. J. Perry; Sec. and Treas., D. A. Peirce.

WILL IT BE UPSET?—Some time ago we announced that the plant and franchise of the Findlay (Ohio) Gas Light Company had been purchased by the city authorities, who proposed thereafter to act in the capacity of public lighting suppliers. It seems, however, that the sale is to be contested, as the following letter proves. Our informant, under date of 2d inst., says: "An injunction suit has been filed in the Court of Common Pleas for Hancock County, Ohio, which is likely to attract a great deal of attention in the Northwestern section of the State. Several months ago the Findlay Gas Light Company made a proposition to the City Council, offering to sell the gas plant to the latter for the sum of \$75,000, the purchase money to be paid in the shape of bonds guaranteed by the city. After considerable debate the Council accepted the offer, the chief argument being that this afforded the only means by which the war of gas rates could be brought to a termination—I presume it is known that the city had been in the field as a competitor for favor against the old Findlay Company in the supply of natural gas for lighting and heating purposes. It is also asserted that this rivalry was causing a loss to the city of something like \$10,000 or \$15,000 per annum. Two weeks ago the plant was turned over to the city's gas trustees, and bonds in the sum named were issued to the Gas Light Company. It seems that the latter speedily repented the course taken, because, on the morning of the 2d inst., Dr. Chas. Osterlin, President of the old Findlay Company, acting in concert with several stockholders, filed a petition praying that the sale be set aside, on the ground of illegality. They assert that the City Council had no authority to issue the bonds, that the Board of Directors of the Company had not consulted them in regard to the sale, and that the terms are very unsatisfactory to complainants. Putting one thing against another, the Findlay sale appears to have been an odd sort of a bargain."

WILL LANCASTER (PA.) HAVE A MUNICIPAL LIGHTING STATION?—At a recent meeting of the Lancaster Select Council Mr. Remley presented a resolution to instruct the Lamp Committee to inquire into the feasibility, and to figure on the cost as well, of converting the old water works building into an electric station for the purpose of electrically illuminating the city. Mr. Remley's associates agreed with him, and unanimously indorsed the resolution.

ALL OVER THE STATE?—The Leavenworth (Kas.) *Times* says there is not now a town in Kansas, containing a population of 3,000, that is without some system of electric lighting.

INCREASING THE CAPITAL STOCK.—Some time ago we chronicled the incorporation of the Cicero (Ills.) Water, Gas and Electric Light Company, the initial capitalization of which was placed at \$65,000. The stock has been increased to \$200,000.

ROME (GA.) TO TRY THE COMBINATION IDEA.—We have it on pretty good authority that the owners of the Rome Gas Light Company are about to add an electric lighting station to their present gas plant.

GAS TURNED ON.—The proprietors of the Standard Gas and Electric Light Company, whose headquarters are at Independence, Iowa, have successfully inaugurated the gas works just completed by them at Macon, Missouri. Gas was first supplied on the night of October 29. It is fully expected that the city authorities will soon enter into a contract for the lighting of the streets of the town by gas. Macon (or Macon City) is the capital of a similarly-named county in Missouri, and is located midway of the streams known respectively as the East Chariton River, and the

Middle Fork of Salt River. It is on the Hannibal and St. Joe Railroad, at a point 70 miles west of Hannibal, 60 miles east of Chillicothe, and 20 miles north of Moberly. A valuable deposit of coal has been found close by, and this insures its prosperity as a manufacturing center. In fact many large establishments—chiefly devoted to the manufacture of farming implements, wagons, etc.—are now in active operation there. Population, close to 6,000. The local post office, by the-way, bears the name, "Macon City."

PROPOSALS FOR STREET LIGHTING, CLEVELAND, OHIO.—Mr. Walter P. Price, City Engineer, Cleveland, Ohio, informs us that sealed proposals will be received at the City Clerk's office—rooms 32 to 35 City Hall—until 12 M., Wednesday, Nov. 30, for furnishing light, lighting, extinguishing and care of about 4,300 gas, and 2,300 vapor or gasoline lamps, and for twenty-six 4,000-candle power electric lights, on masts, and 40 (or more) 2,000-candle power electric lights on posts, arches or brackets, the contracts to cover a period of one year from December 1st next. Specifications may be seen and blank form of proposals can be obtained at Mr. Price's office. Each proposal must be accompanied by a bond in \$5,000.

A NOVEL SUIT.—Recent Philadelphia (Pa.) advices state that Jacob H. Armbruster, who had occupied the premises, 1635 Chestnut street, in the Quaker City, has instituted suit in the Common Pleas against the executors of the estate of Aaron A. Hurley, who are now the owners of the premises, No. 1637 Chestnut street. On June 9th last an explosion of gas occurred in Mr. Armbruster's store and house, whereby, as he alleges, his stock-in-trade and household goods were damaged to the extent of \$1,000. He says the walls of No. 1637 had settled and strained the gas pipes so that the latter leaked badly, the escaping gas subsequently entering his house and causing the damage complained of. He claimed that if the gas had been shut off—No. 1637 was vacant at the time—the accident would not have happened, hence defendant's liability through lack of ordinary caution.

SOME CHANGES IN WEST TROY'S GAS SUPPLY.—A correspondent kindly sends the following: "The connection between the mains of the Municipal Gas Company (Albany, N. Y.) and the holder of the West Troy Gas Light Company has been made, and West Troy consequently uses illuminating gas manufactured in Albany. The connection was made by laying 7,600 feet of 8-inch pipe, from Spring street, on the Albany road, through Salem and Saratoga streets, to the canal, thence along the canal banks to Schenectady street, through that street and Federal and West streets directly to the works of the West Troy Company. Gas making in West Troy has been discontinued for the present, but the works are in such shape that they could be started, if necessary, at short notice. The distribution is, as heretofore, from the West Troy holder. In 1877-8-9 gas was furnished to West Troy from Albany, without an intermediate holder, with the result that the pressure was variable and the supply unreliable and unsatisfactory. By the present arrangement, however, the distribution conditions are the same as if the gas were made on the spot. A reduction ere long is expected in the price of gas, which is pronounced excellent in quality and of high illuminating power. At a meeting of the West Troy Gas Light Company, held Nov. 4, the resignations of the following Directors were received and accepted: G. W. Chapman, F. J. Parmenter, W. A. Thompson, A. H. Sweeney, A. T. Phelps, and R. F. Hall. In their places were substituted Messrs. R. Brice, C. L. Pruyn, W. McEwan, E. A. Groesbeck, L. Cogswell, and E. J. Hussey. R. Bryce was chosen President, and C. L. Pruyn Secretary. T. A. Knickerbacker is the only one of the old Board of Directors who remains, and he also retains his position as Treasurer. R. F. Hall will continue to be Superintendent of the works at West Troy. Messrs. A. N. Brady and R. C. Pruyn, respectively the President and Vice-President of the Municipal Gas Company of Albany, recently purchased a majority of the stock of the West Troy Company, and thus obtained control of its property."

CAN THIS ACCOUNT FOR SOME OF HENRY GEORGE'S QUEER TALK?—During the late political canvass in this State Mr. Dana's paper published a letter from the pen of that celebrated orator (so famous for his San Francisco anti-Chinese "sand-lots" harangues), Denis Kearny, in which the writer asserted that George's earliest political attempt consisted in the successful lobbying through the California Legislature of a measure creating an inspector of gas meters for that State. The lobbyist, it is claimed, was the first one to fill the office so created, although the gentleman from the "sand-lots" intimates that the inspector's chief duty under the act was simply to draw an "unearned increment" from the treasury.

IN CHARGE AT AURORA, ILLS.—We notice, from instructions received to change the address of a subscriber, that Mr. Wm. B. Miller, formerly in charge at Appleton, Wis., is now Secretary and Supt. of the Aurora (Ills.) Gas Light Company. We wish him every possible success.

THE MEN AT THE HELM.—The Louisville (Ky.) Gas Company was organized in 1838, since which time only six individuals have occupied its Presidential chair. The occupants' names, with their respective terms of office, are appended: L. L. Shreve, 1838 to 1854; R. G. Courtenay, 1854 to 1865; J. L. Smith, 1865 to 1877; H. Whitestone, 1877 to 1884; John G. Baxter, 1884 to 1886; G. W. Morris, 1886 to—let us hope for many years. This list reveals the names of men who, in their day and time, were honored by their fellow-citizens, and whose memories will be recalled with pleasure.

A CHANGE PROPOSED AT WHEELING, WEST VA.—We understand that a change is about to be made in the method of gas making at the Wheeling City Works. It is probable that a process something similar to that of the McKay-Critchlow sort will be adopted.

ANNUAL MEETING, WAUKESHA, WIS.—The annual meeting of the Waukesha American Gas Company was held on Oct. 31. The following officers were elected: President, A. J. Frame; Vice-President, C. E. Gray; Secretary, T. W. Haight; Treasurer, Thos. Robbins, Jr. The business for the year, as shown by the books, returned a fair rate of interest on the money invested. This Company has adopted the combination plan.

BIDS FOR PUBLIC LIGHTING, CONSHOHOCKEN, PA.—At a recent meeting of the Town Council the chief item under discussion was the public lighting contract. The following bids were submitted: Conshohocken Gas Light Company—two proposals. First, to furnish 83 or more 16-candle power incandescent lights at the rate of \$15 per year each; second, to light the streets by means of gas lamps, equipped with 5-foot burners, at \$18 per year each; or with oil lamps, of the pattern now used, at the rate of \$13 each per year. These prices to include the cost of lighting and extinguishing and keeping in order. The Penn. Globe Gas Light Company offered, on the basis of a 5-year contract, to supply a 16 to 18-candle power vapor light for \$22.75 per lamp per year. A syndicate offered to supply a 25-candle power incandescent lamp for \$1.75 per lamp per month, and guaranteed to have their plant in operation within 90 days of the date of acceptance of the proposition. A motion, by Councilman White, to accept the syndicate proposition was defeated, and the body then adjourned.

NEW LIGHTING COMPANY.—Articles incorporating the Kearney Gas and Electric Light Company have been filed with the Secretary of State, Nebraska. The capital stock is placed at \$50,000, and the Company limits its indebtedness to two-thirds of the paid-up capital. Messrs. A. S., E. O., and G. L. Maxwell are the incorporators. Kearney is a post-town of Buffalo county, Neb., on the U. P. and St. Joe and Denver Railroads, at the west terminus of the Burlington and Mo. River Road. It is near the Platte river, is 195 miles west by south of Omaha, and 136 miles west of Lincoln. Elevation, 2,150 feet; population, about 4,000.

DE LAND, FLA., is to be lighted by electricity, and the material for the station is now on the ground.

GAS is to be used at an early day for the illumination of the chief public buildings in the town of Natchitoches, La. Natchitoches (pronounced nak'-e-tosh) is on Cane river, at a point 75 miles south-southeast of Shreveport.

COMBINING AT GALVESTON, TEXAS.—We understand that a consolidation has been effected between the Galveston Gas Light Company and the local electric light company, the stockholders in the former having ratified the agreement on the 8th inst. This probably means more work for Brother Beck. A man who had the courage to crawl through some of the Pennsylvania gas coal mines, which he did not such a great while ago and that merely for pleasure, is not likely to consider the new branch of duty thus imposed on him as much of a hardship.

NEW ELECTRIC LIGHT COMPANY.—The Olean (N. Y.) Electric Light Company has been incorporated by Messrs. G. V. Forman, W. V. Franchett, O. T. Coon, L. L. Bartlett, F. W. Higgins, W. Irish, C. S. Stowell, J. Kelsey and L. E. Chapin. Capitalized in \$25,000.

A GAS MACHINE WILL FURNISH THE GAS.—On Oct. 25 the Trustees of the Hospital for the Chronic Insane (located at Agnews, Cal.) authorized Messrs. A. F. Nye & Co., of San Francisco, to supply them with

a 500-light gas machine for the lighting of that institution. Nye & Co., are to be paid \$3,000 under the contract, which we presume includes the cost of piping, etc.

A BIT OF BALTIMORE (MD.) GOSSIP.—Mr. E. C. Benedict, speaking on the subject of the changes now going on concerning the Baltimore Gas Companies, said: "We propose in the consolidation to utilize the plant of the Equitable Company in manufacturing cheap fuel gas for the purposes of generating heat and power. We will begin, say, by charging 75 cents per thousand cubic feet; and it may be, provided we secure consumers enough, that we can furnish it for less."

REVERSING THE DECISION.—The Butte City (Montana) Council, about a month ago, decided to enter into a contract with the local Gas Company for the lighting of the city's streets, which action meant the substitution of gas for electricity. The electricians, however, seem to have been equal to the emergency, for we now have information that, on October 29, the Council rescinded its first decision, and then awarded a contract to the electric light men, under the terms of which they will draw a greater sum of money from the public funds than they drew before. Weather-cocks would appear to abound in Butte City's Councilmanic circles.

WE understand that, at a recent election held by the freeholders of Roanoke, Va., it was voted not to light the streets by electricity.

RESULT OF A SUIT FOR DAMAGES.—We are informed that, in accordance with a verdict rendered in the local Circuit Court, Wm. B. Oliphant has been awarded damages in the sum of \$5,000 in his suit against the Danville (Ills.) Gas Light Company. Complainant, who is a dealer in plumbers' and gas fitters' supplies, with place of business in Chicago, was in Danville, on date of August 19, and, while hurrying to the depot to catch a train, he stumbled into a trench that had been opened by the Gas Company for the reception of a pipe. The stumble cost him a broken ankle, hence the suit. He asked for \$10,000.

ABOUT COMPLETED.—The "South-end" gasholder now being constructed for the Springfield (Mass.) Gas Company is rapidly approaching completion. The slate roof to the house is being put on, and it is expected that gas will be turned into the holder on or about December 15. The completion of this holder guarantees to the Company storage facilities for something like 600,000 cu. ft. of gas.

ONE THING THAT WAS WITNESSED!—The Cleveland (Ohio) Board of Improvements recently deputed a party of four to visit Bellevue, Ky., for the purpose of inquiring into the merits of a gas manufacturing process in operation there. Of course, the deputies had a pretty good time, and seem to have been convinced that the Bellevue process, so-to-speak "takes the illumination." In talking about the wonderful things they had seen the deputies mentioned the following to a Cleveland *Press* reporter: "At one of the tests three quarts of water were boiled in considerably less than two minutes, but the volume of gas required to do this was not ascertained!" Somewhat like the ancient parallel about attending a performance of "Hamlet" whereat the melancholy Dane failed to put in an appearance.

A HINT FROM MANCHESTER, N. H.—At a meeting of the Manchester City Fathers, held on the first inst., the rules being temporarily suspended in order to expedite the transaction, the following resolution was passed: "On account of the extravagant cost of lighting our streets by the present method, it is moved that a joint standing committee of two Aldermen and three Councilmen be appointed to investigate the cost and feasibility of establishing an electric light plant for the city." The committee selected includes Aids. Eager and Reynolds, with Councilmen Kendall, Bohan and Woodbury.

WHAT IS THE MATTER WITH THE PROPRIETORS?—We have been told by a gentleman, just home from a visit to the Isthmus, that the Panama Gas Company's plant is in a very dilapidated condition. This is a queer state of affairs, for, with proper management, an enterprise of that sort in the locality named ought to prove a profitable one to those in charge of it.

QUITE A GOOD SHOWING.—So far this year the National Gas Light and Fuel Company, of Chicago, Ills., have put in their Springer cupola gas system in 15 different gas works. The total daily manufacturing capacity represented by these contracts figures out at something over 4 millions cubic feet.

PROGRESS MADE ON THE VANCOUVER (BRIT. COL.) GAS WORKS.—Some time ago we noted that Vancouver was to have a gas plant, and we can now add that the work of construction has been prosecuted with remarkable vigor. The buildings are well underway, the gasholder is finished, and about 2½ miles of mains have been buried. The proprietors hope to begin the supply of gas in a month or so, and we congratulate them upon having secured the services of such an enterprising and clever man as Mr. J. L. Stamford, who acts in the capacity of Manager and Engineer of the Company. Vancouver has had an electric light company in active operation for some time back, but the service does not seem to give general satisfaction. However, the residents will soon have a chance to compare the merits of the two systems of illumination.

CHARTERED.—The Peoples Heat, Light and Power Company, to operate in Fort Scott, Kansas, has been incorporated by Messrs. A. A. Harris, W. C. Gunn, C. H. Osborne, E. P. Ware and D. Prager. It is capitalized in \$100,000.

THE GASOLINE STOVE.—The Kansas City (Mo.) Fire Department apparatus was called out twice on the 29th of October to extinguish conflagrations caused in each instance by the explosion of a gasoline stove. The total damage amounted to \$6,500. Better use gas stoves. They are cheaper than the gasoline apparatus even when the results are calculated in dollars and cents. Safety, however, ought to be worth something.

GOING LOWER IN LONDON, ENGLAND.—We note the Directors of the Gas Light and Coke Company, London, have resolved, from and after the 1st of January next, to reduce the price of gas to private consumers on the north side of the Thames river to 67 cents per 1,000 cubic feet for common gas, and to 84 cents per 1,000 for cannel gas. They have also resolved, from and after the same date, to supply the public lamps over their entire district at 53 cents per 1,000 cu. ft. for common gas, and at 65 cents per 1,000 for the cannel quality.

PUBLIC LIGHTING AT PORTLAND, MAINE.—The Portland City Council decided to accept the bid submitted by the Consolidated Electric Light Company for the public lighting of that city, the contract to begin on November 1, 1887, and to terminate on Oct. 31, 1888. The Company agreed to maintain 168 arc and 250 incandescent electric lamps in consideration of a total annual payment of \$25,000. Each additional arc ordered is to be paid for at the rate of \$140 per year, \$18 per annum to be paid for each extra incandescent lamp ordered. Last year the electric lighting of the city cost the taxpayers \$18,000.

THEY WANT GAS.—The residents of Menominee, Mich., are agitating the subject of a gas supply. The situation seems to be a favorable one. Menominee is the capital seat of a similarly-named county, and is located at the junction of the Menominee River and Green Bay. It is 52 miles northeast of the city of Green Bay. Population, about 4,200.

HEARD FROM ONCE MORE.—Our last information concerning Brother Cressler's whereabouts appeared to locate him at Chattanooga, Tenn., where, something like a fortnight ago, he was busily engaged in completing the additions made by the Kerr Murray Company to the local gas plant.

THE COST.—It is estimated that the sum of \$60,000 has been expended in carrying out the extensive system of improvements made on the works of the Burlington (Iowa) Company this season. Quite a round sum.

THE CAPITAL STOCK OF THE NEWBURGH (N. Y.) ELECTRIC LIGHT COMPANY has been increased to \$150,000. Additional apparatus has been purchased.

AN "APPROVED" ELECTRIC LAMP POST.—It seems that President Hess and Engineer Kearney, the committee appointed by the New York Board of Electrical Control to adopt a design for uniform lamp posts to be erected by the electric light companies of this city in the future, have fixed upon a design, and no permits will be granted by the Board for the erection of lamp posts of any other pattern, unless for some special reason the specimen adopted is shown to be impracticable in certain parts of the city. The selected design contemplates a pole 20 feet high, exclusive of the lamp frame. For a distance of 7 feet from the surface of the ground the pole is to be of iron, the remaining 13 feet to be of hard wood. This combination of materials is intended to prevent, in a measure at least, all danger to human life by shocks, as the wires carrying the current will not be visible at any point on the iron pedestal. The post is to be ornamental in design, and no part of the pattern is covered by any patent.

POLICEMEN DO NOT WANT TO ACT AS LAMPLIGHTERS.—The Pittsburgh (Pa.) *Dispatch* says that the policemen in the adjoining city of Allegheny are busy buttonholing Councilmen about a grievance which they want remedied. The police are required to light the lamps and put them out before reporting off duty a 5 A.M. During the winter months that is an early hour to extinguish the lights, and the workmen have to stumble along the dark streets to their shops. In order to save two hours' time before reporting for duty, the police are compelled to hire boys to do the lighting-up, and this costs the guardians of the peace about \$15 per annum each. They believe this is unjust, and in order to have the streets illuminated until daylight, which cannot be done under the present system, they will solicit Councils to employ regular lamp lighters.

WHERE THEY CAN BE SEEN IN THIS VICINITY.—We are in receipt of the following letter from the main office (Newark, N. J.) of the Albo-Carbon Light Company: "We have pleasure in inclosing you a copy of our new catalogue, by which you will notice we are adding still more elaborate and fancy designs of our specialties especially suited for use in private residences and for church lighting. The inclosed list shows over 20 different styles of our lamps in every grade of elaborate and artistic finish. You are no doubt aware that Messrs. W. M. Crane & Co., our New York city agents, are located in the well-known 'Ye Olde London Streete' building, at No. 728 Broadway. These premises are lighted by our lamps. At the office of Messrs. Crane can be seen an extensive line of Albo-Carbon fixtures. They will, of course, be pleased to show the practical adaptation of our system in any way required." Those interested ought to write for a copy of the new catalogue, which readily explains itself.

DESTROYED.—About three weeks ago the skewer factory of Swezey & Johnson, located in Painesville, Ohio, was destroyed by fire, and the machinery of the electric light company, which was housed in the same building, was badly wrecked. As the public lighting depended on the fractured apparatus, Painesville was relegated to darkness. It seems that by means of a blower the dust from the saws was blown into an adjacent room, close to the boilers, and used for fuel. This dust had been accumulating for several days, and to that accumulation was traced the explosion which preceded the fire. The loss is placed at \$25,000.

TO HOUSE THE PLANT.—Next spring the Meriden (Conn.) Gas Company will erect, on the old South Colony street site, a substantial brick building wherein to house its electric lighting plant.

TUMBLED DOWN.—The pedestrians who happened to be passing along in the vicinity of Tenth street and Kansas avenue (Topeka, Kan.) at about dusk of Oct. 24, were treated to a novel, not to say startling, sight. This was nothing else than the collapse of a 150 feet in height tubular electric light tower, which had been erected by the city in 1880 or '81. The roof-tops in the vicinity of the "all" will need considerable attention at the hands of the roofers ere they can be called water-tight. The iron posts and braces were badly weakened, as investigation proved, although their outward appearance seemed to indicate soundness. Our informant says that the "city authorities recently entered into a contract with the local electric light company to erect a half dozen similar towers in different parts of the city, but the accident will in all probability cause the Common Council to annul the bargain."

IS THERE ROOM FOR THEM?—A correspondent sends the following: "The people of Fort Wayne, Ind., are to be supplied with illuminating gas, at a cost not to exceed 75 cents per 1,000 cu. ft., by the Standard Gas, Fuel and Steam Company, which filed articles of incorporation with the Secretary of State on Oct. 28. The capital stock of the Company is fixed at \$250,000, and the Directors are Messrs. J. R. Markle, J. P. Tillotson, W. S. O'Rourke, R. L. Roney, and S. Miller." These gentlemen are evidently inclined to promise great things: but how as to the performance thereof?

PUBLIC LIGHTING, UTICA, N. Y.—The Council has awarded a contract for lighting the city of Utica to a concern known as the New York Electric Construction Company, supposed to be a branch of the Fort Wayne (Ind.) Jenney Electric Light Company. The contract, which is to run for three years, seems to us to be very loosely drawn. Under its provisions the contractors agree to light the city, in a manner satisfactory to the authorities, in consideration of an annual payment of \$42,000. The lamps are to be kept in duty 27 nights each month, the duration of lighting to be fixed at an average of 10 hours per night.

[OFFICIAL REPORT.—Concluded from page 284.]

Fifteenth Annual Meeting of the American Gas Light Association.

HELD AT DOCKSTADER'S HALL, NEW YORK CITY, OCT. 19, 20, AND 21.

SECOND DAY—MORNING SESSION—OCT. 20.

The President now introduced Mr. Emerson McMillin, of Columbus, Ohio, who read the following paper on

FUEL GAS.

Some years ago one could seldom glance over the pages of any journal, and especially of those devoted to gas interests, without his eye falling upon the words "water gas." From about 1883 until recently, "natural gas" were the magnetic words. Now the absorbing theme seems to be "fuel gas." While water gas and natural gas are both fuel gases, still they do not seem to be the ideal gas in demand.

Water gas probably fails to meet the conception in the minds of the public of what a fuel gas should be—first, because it has not yet been offered to would-be consumers at prices that tend to bring it into general use; second, because water gas, pure and simple, possesses elements of danger, at least greater than that of illuminating gas made by any of the processes now in vogue; and, third, because of a strong prejudice, partly warranted by facts and partly cultivated (involuntarily in many instances) by many of us who are prone to belittle the merits and magnify the evil of things that we prefer should not succeed.

Natural gas fails to satisfy our wants as a fuel gas simply because where we look for it we generally fail to find it. We know that it can be had only in limited portions of our great country, and believe that it will be obtainable in these few favored localities for but a limited time.

If natural gas cannot be had, and water gas is considered in any sense undesirable, why not resort to illuminating gas for fuel?

"Too expensive" must be the answer. If anthracite coal or coke could be had in the Lima (Ohio) oil field at about \$1 per ton, and used in connection with crude oil at present prices, a cheap and excellent illuminating fuel gas could be made. Pittsburgh, located on the margin of the Youghiogheny coal basin, should be able to make a good and very cheap fuel gas. Whether fuel gas can be made cheaply in any particular locality will depend largely upon the quantities in which it shall be produced. If all our consumers would, with one accord, agree to use illuminating gas to the exclusion of all other kinds of fuel, I think most of us could reduce our prices 25 to 50 per cent. from those now prevailing. But the consumers will not all agree, nor any great number of them, to do this; and therefore the gas companies are unable to make such startling reductions as above suggested.

When the writer first embarked in the gas business his employers were selling gas at \$4 per thousand feet, and were unable to make a greater profit than was then considered a fair return on the investment. The consumers, of course, thought the price too high—as they always do; but we said to them that if more people would burn gas, and all who did burn it would do so to the exclusion of other modes of lighting, we would sell the gas cheaper. Most of you have probably used the same argument, and also received about the same answer—viz., "If the gas company would reduce their price we would burn more gas and many more would use it." In this the consumers were right—as they sometimes are. Twenty years later we find ourselves using the same argument and receiving the same answer respecting the sale and use of fuel gas. But the gas fraternity will profit by the 20 years and more of experience, and you will, if I mistake not, soon find gas companies launching out into the business of manufacturing fuel gas that will be sold at prices ranging from 25 to 40 cents per thousand feet.

Do not understand that I believe illuminating gas can soon be sold even at the maximum price named; but a gas that will meet the requirements of a fuel gas will be sold much below the maximum figure.

Good illuminating gas has been sold on some streets in a neighboring city at as low a figure as 35 cents per thousand feet, and I believe the gas has not been extensively used for fuel—other than for culinary purposes; but this fact is doubtless largely due to a conviction in the minds of the people that the low prices were but temporary, and liable to be terminated at any day.

Good illuminating gas, of whatever make, would be as cheap a fuel at \$1 per thousand feet as would uncarburetted water gas at 50 cents per thousand feet. Yet it is quite probable that if the public could have immunity from danger, real or fancied, they would take much more readily to the use of the latter than to that of the former; such would be the magic effect of low prices.

The relative calorific values of the various gases now in use for heating and illumination have been frequently published, yet in the discussion of this subject we cannot well avoid a reproduction of some of the figures.

Notwithstanding the fact that tables of this character have been so often published, we are all more or less confused occasionally by seeing statements made that make the comparison totally different from our preconceived ideas as to their relative calorific value. This confusion occurs from the fact that at one time we see the comparison of the gases made by weight, and at another time the comparison is made by volume.

We present here the comparison made both by weight and by volume, and shall use natural gas as the unit of value in both comparisons:

TABLE I.—Relative Values.

	By Weight.	By Volume.
Natural gas.....	1000	1000
Coal gas.....	949	666
Water gas.....	292	292
Producer gas.....	76.5	130

The water gas rated in the above table, as you will understand, is the gas obtained in the decomposition of steam by incandescent carbon, and does not attempt to fix the calorific value of illuminating water gas—which may be carburetted so as to exceed, when compared by volume, the value of coal gas.

You will observe in the table of values given above that one pound of coal gas is almost equal to a pound of natural gas, while 1,000 feet of coal gas has but two-thirds the value of a like quantity of natural gas. The relative values of water gas and natural gas are the same whether compared by weight or by volume. This is due to the fact that they possess the same specific gravity.

TABLE II.—Composition of Gases.—Volume.

	Natural Gas.	Coal Gas.	Water Gas.	Producer Gas.
Hydrogen.....	2.18	46.00	45.00	6.00
Marsh gas.....	92.60	40.00	2.00	3.00
Carbonic oxide.....	0.50	6.00	45.00	23.50
Olefiant gas.....	0.31	4.00	0.00	0.00
Carbonic acid.....	0.26	0.50	4.00	1.50
Nitrogen.....	3.61	1.50	2.00	65.00
Oxygen.....	0.34	0.50	0.50	0.00
Water vapor.....	0.00	1.50	1.50	1.00
Sulphydic acid.....	0.20
	100.00	100.00	100.00	100.00

TABLE III.—Composition of Gases.—Weight.

	Natural Gas.	Coal Gas.	Water Gas.	Producer Gas.
Hydrogen.....	0.268	8.21	5.431	0.458
Marsh gas.....	90.383	57.20	1.931	1.831
Carbonic oxide.....	0.857	15.02	76.041	25.095
Olefiant gas.....	0.531	10.01	0.000	0.000
Carbonic acid.....	0.700	1.97	10.622	2.517
Nitrogen.....	6.178	3.75	3.380	69.413
Oxygen.....	0.666	1.43	0.965	0.000
Water vapor.....	0.000	2.41	1.630	0.686
Sulphydic acid.....	0.417
	100.000	100.00	100.000	100.000

Some explanation of these analyses is necessary. The natural gas is that of Findlay, Ohio. The coal gas is probably an average sample of coal gas, purified for use as an illuminant. The water gas is that of a sample of gas made for heating, and consequently not purified, hence the larger per cent. of CO₂ that it contains.

Since calculating the tables used in this paper I am satisfied that the sample of water gas is not an average one. The CO is too high and H is too low. Were proper corrections made in this respect it would increase the value in heat units of a pound, but not materially change the value when volume is considered, and as that is the way in which gases are sold, the tables will not be recalculated.

The producer gas is that of an average sample of the Pennsylvania Steel Works, made from anthracite, and is not of so high grade as would be that made from soft coal.

The natural gas excels, as shown in Table I, because of the large per cent. of marsh gas. In no other form in the gases mentioned do we get so much hydrogen in a given volume of gas. It is the large per cent. of hydrogen in the coal gas that makes it so nearly equivalent to the natural gas in a given weight, but much of the hydrogen in coal gas being free, makes it fall far short of natural gas in calorific value per unit of volume.

Water gas is composed, as you know, chiefly of carbonic oxide and hydrogen, both good heating gases, but nearly all the hydrogen being free, makes the actual weight of hydrogen in a given volume fall below that of natural gas; and again you will notice by the analysis given that three-quarters of the weight of water gas is CO, and of this compound four-sevenths is oxy-

gen, which possesses no calorific value; in other words, more than 40 per cent. of the weight of uncarburetted water gas, even when free from CO₂ and nitrogen, fails to add anything to the value of the gas as a heat producer. The producer gas, of which an analysis is given above, does not possess as high calorific value as it would if made from soft coal, but a greater volume can be made from a ton of anthracite or hard coke than can be made from a like quantity of bituminous coal.

A further comparison of the value of the several gases named may be made by showing the quantity of water that would be evaporated by one thousand feet of each kind of gas, allowing an excess of 20 per cent. of air, and permitting the resultant gases to escape at a temperature of 500°. This sort of comparison probably has more practical value than either of the others that have been previously given. We will assume that the air for combustion is entering at a temperature of 60°.

TABLE IV.—Water Evaporation.

	Natural gas.	Coal gas.	Water gas.	Producer gas.
Cubic feet gas.....	1,000	1,000	1,000	1,000
Pounds water.....	893	591	262	115

The theoretical temperature that may be produced by these several gases does not differ greatly as between the three first named. The producer gas falls about 25 per cent. below the others, giving a temperature of only 3,441° F. Water gas leads in this respect with a temperature of 4,850°. A formula for calculating the temperatures theoretically obtained may be as follows:

$$T = \frac{U + H}{WS}, \text{ where}$$

T = Temperature obtained.

U = Units of heat from combustion.

H = Heat units carried in by air.

W = Weight of resultant gases.

S = Specific heat of resultant gases.

A comparison of the resultant products of combustion also shows water gas to possess merit over either natural or coal gas, when the combustion of equal quantities, say, 1,000 feet, is considered. An excess of 20 per cent. of air is calculated in the following table:

TABLE V.—Resultant Gases of Combustion.

Quantity—1,000 feet.	Natural Gas.	Coal Gas.	Water Gas.	Producer Gas.
Weight of gas before combustion, lbs.....	45.60	32.00	45.60	77.50
Steam.....	94.25	69.718	25.104	6.921
Carbonic acid.....	119.59	68.586	61.754	36.456
Sulphuric acid.....	00.36
Nitrogen.....	664.96	427.222	170.958	126.568
Total weight after combust'n	879.16	565.526	257.816	165.945
Lbs. oxyg'n for combinat'n	167.462	107.961	43.149	19.677

While the combustion of 1,000 feet of natural gas vitiates the atmosphere, when consumed under the conditions named, more than five times as much as does the combustion of 1,000 feet of producer gas, yet for the work performed the former vitiates the atmosphere less than does the latter gas.

You will observe by the following table that, with the exception of producer gas, each kind gives off nearly one pound of waste gases for each pound of water evaporated. This quantity includes 20 per cent. excess of air.

TABLE VI.—Weights of Water Evaporated and of Resultant Gases.

	Natural Gas.	Coal Gas.	Water Gas.	Producer Gas.
Weight water evaporated..	893.25	591.	262.	115.1
" gases after combust'n	879.16	565.526	257.816	169.945

The vitiation of the atmosphere per unit of value in water evaporation is precisely the same in water gas as in natural gas. Coal gas shows about 3 per cent. better than either of the two gases named in this respect, and about 50 per cent. better than producer gas.

In the above comparisons all of the resulting products of combustion, including excess of oxygen, are regarded as being of a deleterious character, tending to vitiate the atmosphere. However, the excess of oxygen does no harm, and the steam and nitrogen cannot be regarded as very objectionable products. The gas that robs the air *permanently* of the most oxygen, and produces the greatest quantity of carbonic acid per unit of work, must be classed as the most objectionable from a sanitary standpoint.

TABLE VII.—Oxygen Absorbed and Carbonic Acid Produced.

In Combustion.	Natural Gas.	Coal Gas.	Water Gas.	Producer Gas.
Pounds of oxygen absorbed per 100 lbs. water evap'ed..	18.75	18.27	16.47	17.96
Pounds of CO ₂ produced per 100 lbs. water evaporated..	13.40	11.60	23.57	31.70
Oxygen absorbed plus CO ₂ produced.....	32.15	29.87	40.04	49.66

Here, then, it is shown that if pollution by carbonic acid, and impoverishment by the absorption of oxygen, are equally deleterious to the atmosphere, coal gas stands at the head as being the least objectionable.

It will be conceded that the gas that gives the greatest number of heat units for a given volume, with the least weight of resultant gases of combustion, must possess the greatest value for all ordinary purposes of heating. Notwithstanding this fact there are purposes for which gas is used where this rule would not apply. For instance: Natural gas is not so desirable for gas engines as is coal gas, chiefly because the flame that lights the explosive mixture is too easily extinguished; again, the explosive mixture will not ignite so readily where natural gas is used as it will when coal gas or water gas is used.

For metallurgical purposes the producer gas has one advantage over all other gases in this, that it contains less hydrogen in any and every form than either of the others; and where metal, and especially iron or steel, is to be heated to very high temperatures by direct contact, it is questionable if anything like the full value of the hydrogen is utilized, unless it be combined with oxygen in recuperators and returned in the air used for secondary combustion. While this advantage does not bring producer gas nearly up to the value of any of the other gases, yet it does bring its value nearer to the others than appears from a theoretical calculation.

The producer gas, on the other hand, possesses a disadvantage in connection with metallurgical work in this, that the resultant gases having to pass off at high temperatures, and the weight of these per unit of work being so much greater than that of the other gases, more heat units will thus be wasted. This disadvantage, however, will not be very great where recuperators are employed, nor will it be great when the gas is used for raising steam, or for culinary purposes, or for any purpose which permits the waste gas to finally escape at a low degree of temperature.

In the utilization of coal gas for fuel we do not obtain, even theoretically, much more than 25 per cent. of the energy of the coal from which the gas was made; but this is not a fair way to put it, because we have in the coal gas manufacture the valuable residuals, coke, tar and ammonia. It will only be convenient to compare the processes for the manufacture of two of the gases—water gas and producer gas—and ascertain in which the greater loss of energy is sustained. In making these comparisons we must accept data obtained from practice rather than what might be deduced by theoretical calculation. It would be difficult to calculate what quantity of energy would be wasted in blowing up a heat in a water gas apparatus. We might tell how much heat would be lost in the generation of the steam required if we knew exactly how much of the steam was decomposed. But upon this point there is a great diversity of opinion, some claiming that 90 per cent. is decomposed, while others claim that not more than 25 to 40 per cent. is utilized in the cupolas.

The net results obtained from fuel by the many different works using water gas apparatus vary greatly, doubtless because of the varied conditions under which they are operated. In some works the cupola may run almost constantly, and there the minimum quantity of hard fuel will be required. In smaller works the cupolas will be idle half the time, and there the maximum quantity will be used.

After consultation with a number of the best authorities, and with those of the largest experience, I conclude that about 35 pounds of hard coal or coke is required in the generation of 1,000 feet of water gas for illuminating purposes. But only about two-thirds (or 667 feet) of this is made from the coal and steam, the other third coming from the oil used for enriching. If this be true, then, on that basis, it would require 52 pounds of coke or hard coal to produce 1,000 feet of water gas without the aid of oil.

That, however, is an unfair way to rate it. A large quantity of fuel must be used to vaporize and fix the oil gas, and where oil is not used this fuel may be converted into gas. Here, then, I think we may cut down the fuel required per 1,000 feet from 52 to 42 pounds.

The most accurate trial of which I have obtained a record shows, on a month's run, an average of about 8.75 pounds of coke required for the generation of steam for each 1,000 feet of gas made—and this when using oil; it will of course take more steam when oil is not used. We will increase the steam fuel, then, from 8.75 to 10 pounds, giving total required 52 pounds. But if gas is being made for fuel purposes it is probable that the apparatus would be operated more nearly continuous than it would be in making illuminating gas, and this would tend to a reduction of fuel requirements. We may safely say, then, that not more than 50 pounds of coal or coke would be required in the production of 1,000 feet of fuel water gas. The energy of one pound of hard coal or coke ought to equal 13,000 heat units, but we will rate it at 12,500 units. Then 12,500 multiplied by 50 pounds equals 625,000 units, which represents the energy expended in the production of 1,000 feet of water gas. We obtain from or by the combustion of the gas but 322,346 units.

In the production of producer gas we need not be at a loss as to the energy required to be expended, as it is represented simply by the difference be-

tween the energy of the coal used and of the gas produced—the coal in the producer furnishing its own heat. There will be about 5.85 pounds of gas made for each pound of hard coal or coke charged if no steam is used, which is seldom the case—the weight decreasing with the increased use of steam. If 5.85 pounds of gas is made for each pound of fuel charged, then there will be 13.25 pounds of fuel used for each 1,000 feet of gas made. This is equal to about 150,000 feet per ton of 2,000 pounds.

The heat generated in the manufacture of this producer gas would much more than be sufficient to generate the steam that could be advantageously used in blowing air into the producers, so that no fuel is lost there.

Then we have the quantity of gas made in each instance from a ton of coal as follows :

TABLE VIII.—From 2,000 Pounds of Coal.

	Water Gas.	Producer Gas.
Quantity.....	40,000 ft.	150,000 ft.
Heat units.....	12,893,840	17,468,975
Per cent. of the total value of coal.....	51.9	68.8

In determining the quantity and value of producer gas I have assumed that in a ton (of 2,000 pounds) of hard coal there are 1,750 pounds of carbon, the calorific value of which would be 25,375,000 units. Now, if we convert this carbon to CO there must be a loss of (1,750 × 4.325, or) 7,568,750 units, and this deducted from 25,375,000 leaves 17,806,250 units, instead of 17,468,975 units as given in the table above. This difference is due to using 4.325 as the figures that represent the units of heat produced by burning one pound of carbon to CO, and also for representing the heat units generated in burning a pound of CO to carbonic acid.

In calculating the energy derived from the coal used in the producer furnace we have assumed that the carbon consumed was converted to CO by oxygen from air, and that there was no hydrogen present. This is never the case, however, as there is always some hydrogen in the coal, and some moisture both in the coal and in the air admitted. The hydrogen thus admitted from these sources, as well as that blown in if a steam jet is used, tends to decrease the quantity of gas produced, and to increase the calorific value of a unit of weight, but does not materially change the theoretic value of the total product. The quantity is decreased in the use of steam by diminishing the quantity of nitrogen that would otherwise be admitted with the oxygen of the air.

If the producer gas is made without the introduction of steam or hydrogen in any form, it will have a value of but 117,315 units per 1,000 feet instead of 143,375, the value given to the gas of which the composition is shown in Tables II. and III.

Natural gas cannot be had for general use; coal gas is too expensive; uncarburetted water gas is expensive, and a prejudice exists against its use; producer gas, while it can be very cheaply made, is bulky, and requires a high temperature for ignition. None of these several gases taken alone seems to meet the requirements of a good and cheap fuel gas.

That a cheap fuel gas is in demand is a fact that will not be questioned, and that this demand can and must be met we all believe. How, then, shall the gas be supplied so as to make its use the most effective, the safest, and the most popular, and at the same time with the least expenditure of capital on the part of existing gas companies, is, to my mind, the problem to be solved.

In order to use plants now erected, and to give heating power as well as to impart odor to the product, I would make part coal gas; in order to work up the coke from coal gas benches, and greatly cheapen the final product, I would make part producer gas; and in order to keep up the calorific value of the gas, which would be too low if all the coke from coal gas was converted into producer gas, I would make part water gas.

I would so proportion these several kinds of manufactured gas that the final product would have about the calorific value of water gas. I would do this, not specially because it would be more advantageous to the consumer to pay 40 cents for gas that contains 350,000 units of heat than it would be to pay 80 cents for gas that contains 700,000 units; neither would I supply that character of gas wholly because it would cost less per unit of heat to the manufacturer of the gas; but chiefly because the less the price is per thousand feet—the price per unit of heat being the same in each instance—the more gas will be sold.

If it be a fact that fuel gas must be sold at a low price to induce the public to generally adopt gas heating and cooking in lieu of solid fuel—without much reference to comparative values—then it appears to me that uncarburetted water gas is about the only product now being offered to the public with any reasonable prospect of being received with favor.

Now if we can, by a mixture of these several gases, obtain a product of equal value with water gas as a heat producer, at less cost, we will be taking a step forward.

Let us, then, base our estimates on what may be obtained from one ton (2,000 pounds) of bituminous coal, equal in quality to that obtained in the Youghiogeny coal field of Pennsylvania, one pound of which has a calorific value of, say, 13,500 units.

This ton of coal would produce 10,000 feet of gas, 1,300 pounds of coke, 120 pounds of tar, 120 pounds of ammoniacal liquor, leaving 110 pounds to cover loss of manipulation. The tar may be converted into 500 feet of gas, leaving 100 pounds of residual (of which no further notice is taken), making the total quantity 10,500 feet. The tar at present could be sold with greater profit as tar, but should the manufacture of gas fuel become general the market for tar would soon be over supplied. Of the 1,300 pounds of coke about 300 pounds would be used in heating coal gas retorts. It can easily be shown that the waste heat of the gases from the coal gas furnaces, together with the heat of the gas from the producer, will be much more than sufficient to raise the steam required for the production of the proportion of water gas that is to be made, and still let the furnace gases escape to tall stacks at a temperature in excess of 500°.

The water gas and producer cupola should be so located that the hot coke could be dumped (if not drawn) into them from the retorts. In this way we would introduce heat with the coke from each ton of coal more than equal to that required for the production of 1,000 feet of water gas. There can be no reasonable doubt, I think, of the possibility of making water gas in this way with very much less expenditure of fuel than is now required. But to be safe we shall only estimate the production at the rate of 50,000 feet from 2,000 pounds of fuel.

We will introduce 500 pounds of the coke into the water gas cupola, and the remaining 500 pounds into the producer furnace. From the water gas apparatus we will obtain 12,500 feet of gas, and from the producer 36,800 feet. These quantities added to the 10,500 feet of coal gas makes a total of 59,800 cubic feet, with a calorific value of 17,160,258 units, which equals 63.5 per cent. of the energy of the coal. Considering the character of the gas, the quantity produced by 2,000 pounds of fuel seems small.

It may be well to notice how the quantities of water gas and producer gas were or could be obtained. In putting 500 pounds coke hot from gas retorts into cupolas you will introduce about 220,000 heat units—thus, 500 × 2,000 × .22 = 220,000. Having the benefit of this heat, and not requiring any of the solid fuel to be used in the generation of steam for water gas, our estimate of 25 feet to the pound will not be excessive. 25 × 500 = 12,500 feet water gas.

We will go more into detail respecting the production of producer gas, as perhaps all of you are not so familiar with its manufacture. In the 500 pounds of coke to be used we will have 440 pounds of carbon. By reason of imperfect working of the furnace we must assume that we will get some carbonic acid. This gas is generally made in the producer when there is an excess of steam, low heats, or by the gases escaping through channels in the fuel. We will assume, therefore, that 40 pounds of the carbon is converted into carbonic acid. This gives a little larger per cent. than is previously shown by analysis.

This leaves 400 pounds of carbon of the 500 pounds coke introduced. Of this quantity we will use 133.3 pounds in the decomposition of 200 pounds of steam into H and CO, and the remaining 266.7 pounds carbon will be converted to CO by oxygen from the air. In this manipulation we have a heat production as follows :

From hot coke 500 lbs. × 2,000 × .22.....	220,000
“ 40 lbs. carbon (to CO ₂) × 14,500.....	580,000
“ 400 lbs. “ (to CO) × 4,325.....	1,730,000
Total heat units.....	2,530,000

This takes no note of heat carried in by steam.

Heat expenditures will be about as follows :

By radiation and convection.....	253,000
In the decomposition of 200 lbs. steam (=22.22 lbs. hydrogen × 62,000 =).....	1,377,640
Absorbed by heating from 250° to 1,250° 50 lbs. steam that will probably escape decomposition 50 × 1,000 × .475 =	23,750

Total heat units expended

Units of heat remaining..... 875,610

With this quantity of heat will we have sufficient intensity for the decomposition of steam? Experience says yes; but to determine this theoretically we must first ascertain the composition and the specific heat of gases.

TABLE IX.—Specific Heat of Gases.

Carbonic acid.....	146.67 × .2164 =	37.74
Carbonic oxide.....	933.34 × .248 =	231.47
Nitrogen.....	1,525.35 × .244 =	37.218
Hydrogen.....	22.22 × 3.400 =	75.55
	<u>2,627.58</u>	<u>716.94</u>

$$\frac{716.94}{2627.58} = .273, \text{ or the average specific heat. Then } \frac{875,610}{2627.58 \times .273} = 1221^\circ$$

of temperature.

With free escape from the producer it is not probable that the gases would take up the temperature of the fuel. Experience has shown that the gases escape at a temperature of 750° to 900°. If the gases shall escape at a temperature of 1,000°, then an equal weight of the fuel would be increased.

$\frac{221 \times .273}{.220} = 274^\circ$; and this added to the 1,221° would give the temperature of 1,495°. The gas made in the producer would be about as follows:

TABLE X.—Composition, Quantity and Value of Producer Gas.

Gas.	Weight.	Cu. Ft.	Units.
CO	933.34	12,000	4,036,695
H	22.22	4,000	1,377,640
CO ₂	146.67	1,200	
N.....	1,525.35	19,600	
	2,627.58	36,800	5,414,335

Then we have the mixture of the three products in the proportions given below:

TABLE XI.—Composition, Quantity and Value of Mixed Gases.

Product.	Quantity, Ft.	Value per M.	Total Heat Units.
Coal gas.....	10,500	× 734,976	= 7,717,248
Water gas.....	12,500	× 322,346	= 4,029,330
Producer.....	36,800	× 147,084	= 5,412,692
	59,800	× 287,000	= 17,159,270

$\frac{287,000}{322,346} = .89$. It thus appears that 1,000 feet of this mixture has but 89 per cent. of the value of water gas. The heat units per thousand can only be increased at the expense of reduction in total quantity. The results obtained are not so good as we ought to have. What part of the process has failed to do good work? Let us see.

With 16.8 per cent. of the weight of coal in the coal gas, it gives 28.58 per cent. of the total heat units possible from the coal. With 25 per cent. of the weight of coal used in the production of the producer gas, it gives 20 per cent. of the energy of the coal. With 25 per cent. of the weight of the coal used in the production of the water gas, it gives but 14.92 per cent. of the energy of the coal in heat units.

Here, then, it is clearly shown that the fault lies in the low results obtained from the fuel converted into water gas.

I believe that 25 feet is about all that will, in practice, be obtained from a pound of coke or hard coal with generators as now constructed; but we ought to get better results. Notwithstanding the fact that the water gas gives us poorer net results than either of the other processes, if we are to increase the calorific value of the mixed gas it must be done by decreasing the producer and increasing the proportion of the water gas product.

We will note what the result would have been had the ton of coal been differently treated.

Had the carbon of the coke from the ton of coal been treated in water gas apparatus alone, the quantity would then have been 10,500 feet coal gas plus 20,000 feet water gas, or a total of 30,500 feet, with a total calorific value of 14,164,168 units, which would equal but 52.46 per cent. of the energy of the coal.

In practice, then, the results obtained are about as follows:

From a ton of hard coal in water gas apparatus we get 40,000 feet and 51.9 per cent. of energy. From same quantity hard coal in producer furnace we get 150,000 feet and 68.8 per cent. of energy.

From ton of gas coal, when all the surplus coke is treated in water gas apparatus, we get 30,500 feet and 52.46 per cent. of energy.

From same quantity of soft coal, with half of surplus coke converted to water gas and half to producer gas, we obtain 59,800 feet of gas and 63.5 per cent. of energy.

From a ton of gas coal, converting all the surplus coke to producer gas, we will obtain 84,500 feet of gas and 64.98 per cent. of the energy of the coal.

Producer gas alone cannot be used for domestic purposes. Nor do I think it would be safe to use so large a per cent. of producer gas as can be made from the surplus coke of a ton of gas coal. It would not easily ignite, and under certain conditions might become extinguished without having the supply cut off, and it would therefore be dangerous to use so large a per cent. of it.

Now, had the ton of soft coal been converted directly into water gas, making permanent gas out of the volatile hydrocarbons, we possibly would have obtained as large a per cent. of the value of the coal as would be obtained by first retorting the coal, though this may be questioned; but in passing the volatile hydrocarbons down through incandescent coke in the presence of steam we would, in a large measure if not entirely, break up the compounds of the olefant gas series, to which the odor of coal gas is so largely due, and would also form compounds of less calorific value—that is, the car-

bon would be largely taken from the hydrocarbon compounds and converted into carbonic oxide.

To give the mixed product as high a value in heat units per 1,000 feet as water gas contains, we must change the proportions somewhat, and use 667 pounds of the coke in water gas apparatus, and but 333 pounds of the coke in the producer furnace. Then we will have the proportions and values shown in following table:

TABLE XII.—Mixed Gas.

Product.	Quantity, Ft.	Value per M.	Total Units.
Coal gas.....	10,500	734,976	8,717,248
Water gas.....	16,600	322,346	5,351,944
Producer gas.....	24,500	147,084	3,603,558
	51,600	323,115	16,672,740

In per cent.—Coal gas, 20.35; water gas, 32.17; producer gas, 47.48.

By thus changing the proportions we reduce the total quantity in feet by 8,200, and total heat units by 486,530; but the mixture has been increased in value from 287,000 to 323,115 units per 1,000 feet, or to a value that is a fraction better than water gas, while the quantity of gas is 29 per cent. more than we have estimated that 2,000 pounds hard coal or coke would produce of water gas alone.

Having now ascertained the quantity of gas that can be produced from a ton of gas coal, and of a quality that we believe will be desirable, it is necessary to know the cost of same.

TABLE XIII.—Estimated Cost in Holder.

	Coal Gas.	Water Gas.	Producer Gas.
Labor.....	12c.	5.5c.	1c.
Repairs and incidentals.....	3c.	1.5c.	0.25c.
	15c.	7.0c.	1.25c.
Coal gas.....	10,500 × 15c.	=	\$1.575
Water gas.....	16,600 × 7c.	=	1.162
Producer gas.....	24,500 × 1.25c.	=	.306
	51,600		\$2.043

$\frac{2.043}{51,600} = 3.961$, or about 4 cents per 1,000 feet. If the coal costs \$2 per net ton this item of fuel will add 3.88 cents; and if it costs \$3 it will add 5.72 cents; and if coal costs \$4 per net ton it will add 7.75 cents—making gas cost, per 1,000 feet in holder, 7.88 cents, 9.72 cents, and 11.75 cents respectively.

Do these prices appear very low? They are not only obtainable, but I believe even better results may be had. I may add that the wages item is intended to cover superintendence.

Here we may note some features that to my mind are interesting—that is, the cost of various gases per million units of heat of which they are theoretically capable of producing.

In working out these figures I put wages, repairs, and incidentals, as given in last table, and the cost of a ton of good gas coal at \$2, and a ton of hard coal or coke at same price, and the quantities of production as follows: Coal gas from soft coal 10,000 feet; water gas from hard coal 40,000 feet; and producer gas 150,000 feet.

TABLE XIV.—Cost per Million Units of Heat.

Coal gas.....	734,976 units at 20c.	= 27.21c.
Water gas.....	322,346 " 10.88c.	= 33.75c.
Producer gas.....	117,000 " 2.58c.	= 22.05c.
The mixture.....	323,115 " 7.88c.	= 24.39c.

Thus it will be seen that, after all, coal gas costs but 11.6 per cent. more per unit of heat than the mixture we have worked out. While water gas, per unit of heat, costs 38.38 per cent. more than the mixed product. In arriving at these ratios of cost I speak from knowledge respecting cost of coal gas, and from the testimony of the producers of water gas respecting cost of that product.

If 2,000 pounds of good hard coal or coke can be made to generate the necessary steam and produce 50,000 feet of gas, then upon that basis the cost per million units will be 26.8, or a little lower than coal gas; but this assumes that the wages and repairs would be no greater in producing 50,000 feet than in the production of 40,000 feet—a basis of figuring hardly fair to coal gas.

The mixed gases would have the following composition:

TABLE XV.—Analysis of Fuel Gas.

Hydrogen.....	29.00 per cent.
Marsh gas.....	8.78 "
Carbonic oxide.....	31.18 "
Olefant gas.....	0.81 "
Carbonic acid.....	2.94 "
Nitrogen.....	26.24 "
Oxygen.....	0.26 "
Water vapor.....	0.79 "
	100.00

The specific gravity is 0.683, and 1,000 feet will weigh about 54.6 pounds. Gas of this gravity will require greater pressure to force it through pipes of given diameter than would be required for either coal gas or water gas. If 2 inches water column pressure is required for the delivery of a definite quantity of coal gas, then 2.4 inches would be required for water gas, and 2.6 inches would be required with the fuel gas, for the delivery of equal quantities through same length and diameter of pipe.

Having decided on the kind of gas that will be the most satisfactory—all things considered—and also determined the cost per 1,000 feet for manufacture, it remains now for us to find a market. In a city of 100,000 inhabitants there will be used for fuel, other than for manufacturing, not less than 200,000 tons of coal per year. Gas mains will ordinarily pass the localities where three-fourths of the total quantity of coal would be consumed; but to be within bounds we will assume you can, without more miles of mains than are now in use, substitute with gas fuel one-half, or 100,000 tons of the coal. What quantity of gas will be required to make this substitution? It will require 80,000 feet of our gas to equal in theoretical value one ton (2,000 pounds) of coal. But it is well known to all that not 10 per cent., if indeed 5 per cent. of theoretical value of the coal is utilized in domestic heating.

We will be very liberal and base our calculations on the larger utilization. This, then, brings the coal down to the value of 8,000 feet of gas, provided the full value of the gas can be obtained in practice. But this cannot be done. With proper facilities 75 per cent. of its value might be utilized, but we will put it at only 50 per cent. Then we have 16,000 feet of gas as the equivalent in practice to 2,000 pounds of coal.

We will assume the price of coal at \$3. This price divided by 16 gives a value to the gas of 18.75 cents per thousand. You may, I think, safely add 6.25 cents to that price for the saving in kindling, handling of ashes, and general cleanliness, making value of gas 25 cents per 1,000 feet.

If it requires 16,000 feet of gas to substitute one ton of coal, it will require 1,600,000 feet to substitute 100,000 tons of coal. This will require a daily production of about 4,400,000 feet varying in quantity probably from 3,000,000 minimum in summer to 7,000,000 maximum in winter. The capital required would be very much less per 1,000 feet output than is required in the manufacture of illuminating gas. The distributing portion of the plant would not cost more than one-half, and the manufacturing part not more than one-fourth that required for a coal gas illuminating plant.

Upon this basis an investment of \$2,500,000 should be sufficient. If the gas costs, including repairs, 10 cents in holder, it will cost when sold and collections made, 15 cents per 1,000 feet. Then, selling 1,600,000,000 feet at a profit of 10 cents nets \$160,000. Six per cent. on estimated investment equals \$150,000. Thus it will be seen that if you want 10 per cent. on your investment you will have to sell gas at about 30 cents per 1,000 feet.

You will observe that in the estimate of cost of coal that each dollar of the price per ton equals 2 cents per 1,000 feet on the cost of gas; therefore, to arrive at the cost of gas in localities where coal is above or below \$3 per net ton, additions or subtractions will be made to the estimated cost of 10 cents per 1,000 feet of one cent for each 50 cents variation in price of coal. The margin for profit deduced is not large. However, it will be borne in mind that I gave a value to coal very much above actual results obtained, and placed the value of the gas below where all authorities put it. By a proper adjustment of the value of the two fuels a fair profit may be figured out. I do not believe the gas can be greatly reduced in cost of manufacture below these estimates, nor that it can be sold much above 25 cents per thousand feet.

How this gas shall be consumed is an important problem. Of course, the best way would be to use all the gas in stoves, the way in which that applied to cooking will be used. It will, however, not be possible to induce all the public to substitute stoves for grates. But grates can be filled with refractory material of good radiating power, and the flues above the grates can be closed so as to leave but a very small opening, say that of one or two inches area, which will be sufficient to carry off the products of combustion, and at the same time confining, as it were, the hot gases until the heat shall be imparted to the air and walls of the room.

The total quantity of heat required to be generated for heating a room in this manner will be almost insignificant compared with that required to be generated when the flues have to be open to produce draft, and under which condition there is probably 40 to 50 tons of heated air carried up the chimney for every ton of coal consumed. The expense that would be incurred in preparing an ordinary grate for the economical use of gas would be very small.

Fewer hot air furnaces and fewer steam and hot water radiators would be used were gaseous firing in general use. But the gas could be adapted to these systems very readily by reducing the exit flues and filling furnace boxes with refractory material.

If we are to use our present plants for the manufacture and distribution of fuel gas, then what is to become of the present lighting system? There are

two substitutes. First, there are two or three devices for incandescent gas lighting now struggling for recognition. It has not been the good fortune of the writer to see but one of these in use, and it did not impress him favorably; still it certainly gives more promise of future usefulness than did the incandescent electric light ten years ago. Should there be an incandescent gas burner invented or improved and made a success, then, of course, the problem will be solved. Again, it is proposed to substitute incandescent electric lights for the gas. There is nothing impracticable in this, if you can satisfy the consumer that it is to his interest to make the change from gas to electricity.

During the period of transition from gas to electric lighting one holder may be used for fuel gas; the gas from this to be led to a square or block already provided with incandescent lights. Here the gas main can be cut off from illuminating gas mains and attached to the fuel gas supply. Then the next square can be treated in the same way, until the entire system is changed without inconvenience to consumers. If it shall be found that there are districts supplied with gas which from any cause it would not pay to supply with electric light, those districts could still be supplied with illuminating gas with but slight change in the distributing lines.

Whether electric lighting has made such advancements as to warrant this substitution is a question that must be decided by others. However, from the hundreds of thousands of incandescent burners that we now know are in use we may be justified in asserting that the change is at least practicable.

But that either the incandescent gas burner or the incandescent electric burner should be substituted for gas light is not absolutely essential to the manufacture, sale, and use of fuel gas. Gas companies can and ought to manufacture fuel gas even if in doing so it becomes necessary to duplicate their present lines. The demand for fuel gas, like the demand for electric light, has come to stay. It will not down. Scientific investigators as well as the public insist that there ought to be and must be a change in the mode of domestic and industrial heating. Our present systems are not in keeping with the general progress of the nineteenth century.

In consideration of the powers, rights and franchises conferred on corporate gas companies by the public, these companies should endeavor, even at some financial risk, to solve the problem. But, aside from any moral obligation, as a matter of policy the gas companies should lead off in these investigations. If they do not do it you will, before long, find other companies asking for franchises and the right to tear up the streets. These companies will lack the experience now possessed by the old gas companies, and must work with less probability that success will crown their efforts.

Let the policy and practice of gas companies be such as shall discourage the duplication of capital. Where one capital can do the business, it is almost criminal to permit two to be invested.

Discussion.

Mr. A. C. Humphreys—Quite likely it is apparent to all of us that it is almost impossible to discuss such a paper as this without having the paper before us. I think that fact alone should force upon us at this meeting the necessity of having the papers recommended by the Executive Committee printed at least two weeks ahead of the meeting of the Association, so they may be sent in advance to the members for their study, to the end that we may be prepared to discuss them properly. Such is the practice in some of the engineering societies in this country, and I do not think we should be behind. I think every member of the Association who listened to this paper will feel that a vote of thanks will not repay Mr. McMillin's efforts. We ought individually to feel grateful to him for such a presentment of the subject, for I think it is the most important subject we have before us at this meeting. The questions of fuel gas and incandescent lighting run right together. We have heard in the Address by the President, as well as in some references by Mr. McMillin, something on the subject of incandescent lighting. Now, it is not my purpose to drag in any discussion on that point—in fact, as far as I am concerned, I would not be dragged into it; but, since the subject did come up, it is perhaps incumbent on me to say I know positively that the experiments given do not cover all the ground. In fact, referring to the most prominent burner before you—the Welsbach—I will say we at least are perfectly willing to leave that without discussion, for we know what will be the result. There are one or two questions I would like to ask, for the better clearing up of the subject. In the figures given as to the relative evaporative powers of the gases, were there any experiments made, or was the result simply determined from calculation?

Mr. McMillin—The figures are the result of both. I think recorded experiments, generally speaking, will verify the data upon all such questions. These theoretical values are obtained from experiments in the first place; and any experiments that I have ever known to be made have usually verified those as closely as it would be possible for crude apparatus to so do.

Mr. A. C. Humphreys—Of course I make that inquiry, as Mr. McMillin knows, because (especially in the case of water gas) the statement has been made by metallurgical men that the theoretical value could not be arrived at. Does or does not Mr. McMillin think that the 20 per cent. air dilution could be greatly improved upon by the aid of improved devices?

Mr. McMillin—It would not materially change it. I put it at figures which should not be excelled in any event. Certainly one ought not to use more than 20 per cent. I will say, however, that in the neighborhood of Pittsburgh, although they use a great deal more than that, there is no necessity for it. But there is no object in economizing there, as they buy the gas for so much per ton of iron or steel.

Mr. A. C. Humphreys—You believe the methods now pursued in the consumption of natural gas are extremely crude?

Mr. McMillin—Yes.

Mr. A. C. Humphreys—In burning off the C after the CO—do you call that an entire loss? In other words, is there a partial combustion of coal in the generator?

Mr. McMillin—In calculating the value of it I take the gas after it leaves there, whatever that may be. If you were using that gas where you could utilize the heat generated at the time, you could then doubtless utilize a great deal of it, because you might get it in there at 500° or 600° of temperature. But if it must be cooled and put into holders, of course it would only have the value of CO afterward.

Mr. A. C. Humphreys—Then it is taken in the account that that partial combustion can be recovered to a greater or less extent?

Mr. McMillin—Yes.

Mr. A. C. Humphreys—With regard to the mixture of gas, I believe the final outcome will be that a mixture of coal gas with water gas will be made directly. In other words, we will be able to make water gas from soft coal. That there is a necessity for a gas, other than what we now call non-luminous water gas, is very apparent. It would not be safe, in my opinion; and I would be unwilling to recommend the distribution of uncarburetted water gas, simply because we are unable to detect its presence. But I do not regard that as being at all out of the way. I do not think we should be discouraged in that direction, as we can easily impart an odor to the gas. I think it will be done by making water gas from soft coal—in other words, that there will be a union, finally, of the water and the coal gas men.

Mr. McMillin—I want to add I heartily agree with Mr. Humphreys upon that point. Notwithstanding the fact that, if done at all, certainly not until recently has water gas been successfully manufactured from soft coal, I feel sure that eventually not only the coal gas but water gas and producer gas will all be made in the same vessel. There, to my mind, would be the greatest economy in the manufacture of producer gas, because you can decompose enough steam by the heat which would otherwise be wasted in the production of producer gas to a very considerable extent. I believe I showed in my paper, by the burning of 133 pounds you can decompose 200 pounds of steam; and it is possible you might go still further. Certainly there is no other way in which you can so economically utilize the heat that is made in the producer, in the burning of air and carbon to CO, as in converting steam into water gas. The three gas mixtures will, I think, eventually be made in that way. I think that is what we will all have to come to. It is a little hard for us coal gas fellows to feel that after a while we will be making our coal gas in a water gas apparatus; but still I think we will have to come to it.

Mr. Graeff—Do I understand you to say that water gas would be made from bituminous coal, or that it was being so made?

Mr. McMillin—I said it had not been successfully made—certainly not until recently. We hardly have time to investigate all the things as we go along. I believe Mr. Loomis has a process in use in Philadelphia, where he is using bituminous slag; and I have seen a notice to the effect that Prof. Lowe is lighting up Los Angeles, Cal., under a somewhat similar plan. These systems, of course, may not prove to be all that is desired; but it will come eventually, even if we have not got it now. There are several generators on the market, or struggling for recognition at the present time, with which it is proposed to use soft coal, right in the cupola. I can only wish them a hearty success.

The President—I entirely agree with Mr. Humphreys as to the value of the paper we have just had read. Certainly, all these papers which carry statistics ought to be printed before the meetings of the Association, and I think it is well worthy the attention of the Executive Committee to see that hereafter this shall be done; but it would be pretty hard to require that they shall be sent two weeks in advance of the meeting of the Association, as most men who write papers find it impossible to prepare them until the last moment—or at any rate, which

amounts to the same thing, they are apt to postpone their preparation until that time. I would like to say something in reply to what Mr. Humphreys said in regard to the suggestion of Mr. McMillin, as well as that made by myself, in the matter of incandescent gas burners. You will find, in reading what I have said, that I carefully qualified my remarks; and so has Mr. McMillin. I suggested that, in my opinion, incandescent gas burners, although not in every way desirable at the present time, still are shown to be much further advanced than were the electricians 15 years ago. As to the incandescent burners heretofore put upon the market in Europe, I will stand by my statement that they have not been the success which has been desired.

Mr. King—I would like to understand the basis of the heat units in the calculations made by Mr. McMillin.

Mr. McMillin—I used the English unit, because I supposed most of our members were more familiar with it.

Mr. Lowe—I had no intention of speaking of the Los Angeles matter. In fact, I do not think anything that has been in operation only a short time, like our method there or that of the Loomis people in Philadelphia, is worthy of discussion here, because these things are foreign to our subject. I want to ask Mr. McMillin as to the cost of gas in the holder, based on coal at \$5 per ton. I have been unable to follow the tables given.

Mr. McMillin—The tables show the cost, practically, to be 10 cents with coal at \$3. If you add one cent for each 50 cents increase in the cost of coal per ton, you can make the calculation.

Mr. Lowe—That would make the cost of your gas 14 cents in the holder, as I understand you. This gas has a calorific value, then, of about what ordinary crude water gas has?

Mr. McMillin—Yes.

Mr. Lowe—Quite flattering to the water gas, at any rate. Then your gas consists of about one-fourth nitrogen. I think you stated it at 26 per cent.

Mr. McMillin—Yes.

Mr. Lowe—As matter of fact, then, your gas is considerably poorer than water gas, and lower in calorific value, inasmuch as you must heat up that nitrogen at the cost of combustion of your gas before you have the value of your combustion of gas.

Mr. McMillin—You speak of calorific value; I supposed you referred to the theoretic value. The available value is a matter that I called attention to in my paper.

Mr. Lowe—That would be greater where your gases escape at a high temperature and it would be smaller where they escape at a low temperature.

Mr. McMillin—Yes.

Mr. Lowe—But, as matter of fact, you use more nitrogen to heat up that gas.

Mr. McMillin—Yes.

Mr. Lowe—Then your gas would not be as good as water gas. How could you—

Mr. McMillin—Make your speech, and then I will make mine.

Mr. Lowe—You gave us 40,000 feet of gas per ton of coal as the fair output of water gas. Have you ever made fuel water gas?

Mr. McMillin—Not very extensively.

Mr. Lowe—In Lynn, on the very small daily quantity of gas now being made there, we get 60,000 feet of gas out of 2,240 pounds of coal. I am sure I can get as high as 80,000 feet from one ton of coal on a production of 500,000 feet of gas per day. Of course the cost of the gas depends to a great extent on the amount made. I do not know that your paper stated anything about the amounts of gas made in proportion to the cost of the gas; but that has a great deal to do with the matter. I think, in the case of water gas, it has considerable more to do with it than in the case of the gas you mentioned, because we can, by increasing the size of our apparatus, get considerably more gas from it for the same labor than you can by increasing your retort system, inasmuch as when you increase your retort system you increase your labor account, which we do not do at all. I do not think, on the whole, that the gas is as good in any respect as uncarburetted water gas. You could not use your gas in a gas engine, as made to-day, nearly so well as we can, for the reason that one-quarter of the gas in the cylinder of the engine would be an incombustible mass. Therefore, I doubt whether your gas would have much value for driving a gas engine.

Mr. McMillin—But it is driving more engines now than water gas is.

Mr. Lowe—We are only driving five in Lynn, but we are doing so quite satisfactorily. I think this gas you speak of is made by the process advocated by the Westinghouse people, of Pittsburgh; is it not?

Mr. McMillin—Not that I am aware of.

Mr. Lowe—I think I saw something of that kind stated in a paper

which you had read before a geological society in Ohio, mentioned recently in a Philadelphia paper.

Mr. McMillin—That had a different composition.

Mr. Lowe—So far as I can judge, I do not see you have shown us that your gas, taking water gas as a standard, is as good as our crude water gas; that you have shown that it costs more than I can put gas into the holder for; and that you have not allowed a fair amount of gas per ton of coal. I do not know but what that would be in your favor in your case, because we can make more than you could.

Mr. McMillin—I am glad you noticed that.

Mr. Lowe—I think the point that I called your attention to before is one generally overlooked by gas men when they speak of the difference of thermal units in the gas. They do not take into consideration the amount of heat which they carry away from the gas when they mix it with air. As matter of fact, I have taken a quart of water and boiled it with less water gas than I could with coal gas diluted with air. By differing the amounts, I have reversed that. In fact, I do not know but I can show, in favor of almost any system, very satisfactory results in theory. I do not think you have shown that your gas is any better than the crude water gas. I am a strong adherent of crude water gas. I would like to have you show us just where the gases are of equal theoretical value, as far as heat is concerned, and where your gas is as good as water gas.

The President—If anyone else desires to question Mr. McMillin I hope he will do so promptly. We are pressed for time, and must soon draw this discussion to a close.

Mr. Loomis—I am very much pleased with Mr. McMillin's paper. I think he has given us a very fair account, and that the paper is well worthy our consideration. With regard to this mixture of gases, I may say I have an apparatus at work at Turner's Falls, Mass., and hope in a few days to be able to give the results. I am arranging to have these gases mixed, or so that we can use pure water gas, and any quantity of coal gas, having them mixed in one holder or the other. Meters will be supplied, and the gas will be put on to the forges to be used in crucible steel melting, iron melting, and all that class of work. I will make this gas, as well as pure water gas, in the same generator, and carry it into the different holders, in the same operation—only at different times; and then I will invite this Investigating Committee which you propose to appoint to come there and investigate it, and they will be able to report just what can be done. We shall have an analysis of the gas made in each case.

The President—I think that will be beyond the scope of that Committee.

Mr. Loomis—Or any other Committee you may appoint. Any who wish to come there will be able to see what is done.

Mr. A. C. Wood—I have listened with a great deal of pleasure to the paper read by Mr. McMillin, and if I understand the case aright his presentation of it is altogether theoretical or speculative. I am quite surprised at the results he arrived at in the volumes of gases required for the work, for we have the testimony of our own members here, who tell us their actual experience of the volume of natural gas required to do the work of a ton of coal. If I remember rightly it varies, in different localities, from 22,000 to 30,000 feet to do the work of a ton of coal of 2,000 pounds. Further than that, we have the written testimony of the projector of a water gas system, claimed to be far superior to all others, that from actual test (nothing speculative about this), and from his own knowledge, 1,000 feet of fuel water gas is equal in value to 40 pounds of coal, or 50,000 feet to 2,000 pounds of coal, consequently I am quite surprised at the volume that Mr. McMillin arrives at in producing equal value to a ton of coal.

Mr. McMillin—Out of 16,000, do you mean?

Mr. A. C. Wood—Yes.

Mr. Lowe—I would like to ask another question. Will you kindly tell me the ignition temperature of this mixture which you speak of?

Mr. McMillin—I do not believe I figured that out. I should judge it was about 4,000. I will say, in figuring these values of the gases, I was aware that, in water evaporation of a 1,000 pounds of each, the extra nitrogen, or the extra quantity of air that may be in any of them, is taken into consideration—that is, of all the gases escaping at 500°. First, we have to compare the specific heats of the gases, working upon that basis. That is already accounted for in any statement I have made. I do not think I worked out the flame temperature of the gas, but judged it to be about 4,000—quite high enough. The producer gas makes a temperature quite high enough for all metallurgical purposes. Mr. Wood speaks of 20,000 or 25,000 feet of natural gas being equal to a ton of coal. That is a theoretical value and not a practical one. Just so it is with your water gas men. I cannot help what men may have said; I speak of what the

fact is. In respect to water gas he is giving the theoretical value. I give the theoretical value of this as requiring 80,000 feet to a ton of coal; yet I say 16,000 feet would, in practice, be equal to a ton of coal. As to the nitrogen in the mixture, I would prefer to have that mixture without the nitrogen. Not being an expert in the manufacture of that gas, of course, I could not get it done as cheaply as Mr. Lowe makes water gas at Lynn. In figuring the cost of water gas I did not take my own ideas about it at all; I took those of large water gas producers, such as the firms in Chicago, Philadelphia, and other places—and, among others, Prof. Lowe. I have taken all the testimony that I could get as to the cost of the gas. I do say we ought to get better results; but I question whether it is a physical possibility to get 80,000 feet of gas and generate your steam and decompose it. I question very seriously whether there is heat enough there to get 80,000 feet of water gas per ton of coal.

Mr. Lowe—Theoretically you can get 120,000 feet of water gas.

Mr. McMillin—I beg your pardon; you cannot do it theoretically.

Mr. Lowe—You can, providing the coal is pure carbon.

Mr. Clark—Recognizing the importance and value of Mr. McMillin's paper, I move a hearty vote of thanks be extended to him, and that printed copies of his paper be distributed among the members at as early a day as possible. [Seconded by Mr. Lowe.]

Mr. McMillin—I have always opposed the distribution of printed copies of papers, and I must oppose this motion now. When I was President of the Ohio Association I broke through the rule with respect to having the President's address printed. This will all come out in due time through the regular journals, so do not let us make any exception in respect to the printing of papers, or distributing them, unless the party does it himself before the meeting. You will get the paper in a few weeks anyhow, and it will keep.

The President—I think Mr. McMillin's suggestion is a good one. [Mr. Clark's motion prevailed.]

REPORT OF SPECIAL COMMITTEE ON A UNIFORM STANDARD OF METER CONNECTIONS.

Mr. Goodwin—If it is the pleasure of the Association the Special Committee appointed yesterday morning to consider the subject of a uniform standard of meter connections beg leave to make a report. I will say also that the meter manufacturers named on the Committee were all present, with the exception of Mr. Tufts, who was not able to arrange for leaving his city at such short notice. This is their verdict:

The Committee to whom was referred the question of uniformity of meter coupling beg leave to submit the following report: That it is the sense of the meter manufacturers that there should be a uniformity of standard of coupling, but the subject is of such importance that the time at their command will not admit of its proper consideration at this date. They therefore ask that they be continued until the next annual meeting, at which time they will be prepared to report.

In the mean time your Committee ask that the Association express its opinion on the desirability of adopting a uniform standard. Your Committee further request, if it is the sense of the Association to adopt a standard, that the Secretary of the Association be instructed to forward a certified copy of such action to the New England, Western and Ohio Associations, and solicit similar action on their part.

Mr. Harbison—I move the report of the Committee be accepted, and that the matter be recommitted to them, to report definitely at the next annual meeting. Also, that it is the sense of this Association that a standard coupling is desirable. [Adopted.]

Mr. E. J. King, of Jacksonville, Ills., read a paper on—

THE ADVANTAGES OF GAS COMPANIES ENGAGING IN THE ELECTRIC LIGHT BUSINESS.

That the electric light must either be looked upon as a rival interest and an active competitor, or a part of the gas undertakings of this country can no longer be doubted. I take it that your Committee, in assigning me this subject, had in mind the discussion of the question whether or not the advantages that gas companies may have over all others are such as to warrant them in the necessary outlay for the installation of a plant, with not only the possibility but probability of competition.

From the number of companies "joining the ranks" I think it has been decided that it may be considered a legitimate part of our business. That, with a properly constructed plant conducted on business principles, it can be made a profitable investment, I no longer doubt.

In a reported interview the manager of a large electric lighting system is quoted as saying he did not advocate the policy of selling to gas companies, as they would not endeavor to push the light as others would who depended solely on this light for their business. It seems to me he could not have looked very far ahead; for when gas companies shall have

taken hold and made it a part of their business, he who has courted their trade will certainly come out in the lead.

I do not believe that electricity is to drive gas for illumination out of the field, and that we can be comforted by knowing that our existing plant is to be devoted exclusively to "sending out" fuel. I do believe there is a place for electricity, that we as gas men are the proper ones to supply it, and that the time is coming when it will be so considered by all.

There was a good deal of philosophy in the reply of a certain gas man who, when asked if it were true that his company was going to enter the electrical field, replied, "Yes; and I should not be surprised if we were selling coal oil before long. We are in the light business."

So far the competition of electric light has not seemed to diminish the use of gas to any extent; in fact most gas companies report not only the average but even a larger increase than usual in their "sendout." But if the use of electricity continues to increase as it has in the last few years, will this always be true?

In our section of the country the arc light has almost superseded gas for street illumination. All buildings in course of construction, of any size or importance, in the various cities of the country are being wired for incandescent lighting. The report comes that all manufacturing establishments supplying electric lighting material are far behind their orders. Does all this mean that after 6 or 7 years' use it has been found unprofitable to engage in electric lighting? or that the demand is growing less?

Undoubtedly there have been failures and unprofitable investments in this field; but has failure been the rule? I certainly have not heard of a gas company that tried the experiment and failed. Now, let us see what advantages the average gas company may have.

First.—I would say, in saving on cost of installation, the probability is that all companies can find the small piece of ground necessary on the property they own, and, maybe, sufficient room in present buildings—by rearranging and economizing in space. For necessary foundations, a grout made of old retorts, firebricks and refuse of various kinds, broken to the proper size, can be utilized with spent lime—which is almost as good as cement for this purpose.

Second.—The saving in expense of management cannot be questioned. That, with the force necessarily a part of the gas plant, fewer men will be needed must be apparent.

Third.—Gas companies have a certain amount of refuse that otherwise would be waste, which can be used for fuel. For instance, coal dust, coke breeze, and more or less coke that can be secured by screening their cinders. All these we use on ordinary grate bars, with the help of a Parson's blower. If a furnace adapted more especially for this kind of fuel, say, something on the plan of our regenerative or recuperative furnaces, made to supply a battery of boilers, were used, the expense might be reduced to a minimum. Many are using the "Jarvis setting" to good advantage. Burners for using oil and tar are also being perfected. Possibly, when prices for tar are such as have obtained during the last few years in many parts of the country, it might be found profitable to make light of it.

Lastly.—Fuel gas. Who can realize the possibilities and advantages that gas companies may have over all competitors when they shall be able to use for fuel, or directly in the engine, a gas that costs them but from two to three cents per 1,000 cubic feet? This, you know, we are promised.

In several discussions in our Western Association it has been argued that interest on the proportion of value absorbed from the existing gas plant in construction, and its proportion of the expense of managing, etc., should properly be charged up to electric light, which would decrease the reported per cent. of profit. Grant this be true; but would you not then have another advantage to gas companies, in that their expenses would be decreased just so much—the result to the stockholder, however, being just the same in dollars and cents?

Now, may it not also be an advantage to the consumer? It has been the history of gas companies that they have endeavored to furnish gas at as low a price as possible, in justice to themselves—the "dollar mark" being the dream. May we not expect them to carry the same policy into any new departures? I know this to be the feeling of the Directors of the Company I have the honor to serve. Taking hold of the electric light when a local company made a failure of it, they have reduced the price from \$12 and \$15, for an 11-o'clock circuit, to from \$6.25 to \$8 for a 12-o'clock circuit. What company in the country, without competition, is supplying arc lighting at the price noted? What company can do so, and pay satisfactory dividends, with only a 63-light plant, unless it be a gas company? Is it not true, also, that men educated to the business of furnishing light will understand the necessities and wants of their patrons better than men who have suddenly entered a new field?

The tendency of the day is to trusts and combinations generally, with the understanding that a great saving may be expected. How truly this may be applied to the question we have now under consideration. I have corresponded with and talked to quite a number of the members of gas companies who have made such a combination, and in no case have I heard them complain they made a mistake. There are, no doubt, many other advantages that might be claimed which have not occurred to me; but I believe those I have enumerated are sufficient to make an electric light plant a profitable investment to gas companies, when to others not so favored it would prove an absolute loss—at least this is true in small and medium-sized cities.

Discussion.

Mr. Pearson—I belong to a Company (Toronto, Can.) which has not yet seen its way clear to adopt the electric light. My opinion is that it depends a great deal upon the ability of the company to sell cheap gas as to whether or not it would be advisable to adopt the electric light. So far as Toronto is concerned we have been enabled successfully to compete with the electric light. The fact of the matter is that the use of the electric light in our city has not advanced at all since they commenced it some 3 years ago, excepting as to the number of lights which the city leases. As a matter of fact I think I am within truth in stating that scores of people that tried the arc electric light after a time gave it up, because the expense was greater than that of gas, and also because of its inconvenience. The introduction by our Company of gas lamps of high illuminating power has enabled us not only to successfully compete with the electric light for inside illumination, but also to have these lanterns substituted for electric lights on the outside of buildings. The lamps that I refer to (of course, there are many others probably equally good) are what are called the "Lambeth Lanterns," made in England. These consume about 25 feet of gas per hour, and supposing they are lighted, say, for 5 hours (which is really as long a time as they are required to be lighted for advertising purposes), then the amount of gas consumed would be only 125 feet, which, at our lowest gas rate, would only amount for the whole night to about 13 or 14 cents, as against from 30 to 50 cents charged by the electric light company for their lights. Therefore, you see that with this lantern—which is quite as effective for their purposes, and sometimes more so than the electric light, for a little more than one-fourth of the price—they have an excellent service. The Gas Company's business in Toronto has increased, as we reduced the price of gas, very largely, far more than the increase in population of the city, which also is large. The electric light, as I have just said, has not increased. We have in our city, with a population of over 140,000 people, but 66 private arc lights, and, I think, 100 public lights, while we have 9,065 gas consumers, and 3,020 ordinary gas lamps. We have introduced for the city 63 of these Lambeth lanterns, and we supply 83 of them to private consumers. The price charged (of course, this is an important factor) by the electric light company to the city was 55 cents, but it has been recently reduced to 50 cents per night. The price charged for the gas lanterns and for ordinary gas lamps—the Company putting in the pipes, attending to the lamps, and doing everything connected with them—is, for a burner $3\frac{1}{2}$ feet per hour, \$20.50. The price for gas charged by the Company to ordinary consumers is now \$1.25; to consumers of over £00,000 feet, \$1.15; over 500,000 feet, \$1; to gas stoves and engines, \$1. The actual increase in the business of the Company during the past year has been nearly 17 per cent., whereas the actual increase in the population has been about 8 per cent. I do not say that it may not be well for gas companies in some places to use the electric light, but I cannot see that it would be well for us in Toronto. Why should we, even if we could supply electric light cheaper than other people, thus bring it into the market? Why should we do that, and make a smaller profit out of that light than we make out of our gas, and thereby hurt our business by so doing? Again, what guarantee have we, should we adopt any one system, that somebody else would not come in to oppose us, and, perhaps, do so without a profit to themselves for a considerable time.

The President—I think the Association would like to hear from some gentlemen who are doing this thing. Perhaps Mr. Stiness will be willing to say something upon the subject.

Mr. Stiness—I suppose that for many years I have been regarded as somewhat of a crank for favoring the adoption of the electric light by the gas companies of this country. That a very large number of them have now come into line is a matter of satisfaction to me. As our friend from Toronto says, perhaps individual cases exist where it may be not for the best interests, financially, of the gas company to adopt the electric light system; but, sir, as sure as the sun shines to-day, the electric light has come to stay, and to exist as an active competitor of gas. I am not one of those who believe or maintain that the gas works of the United States are to be annihilated, or are to be entirely turned into

mediums for furnishing heating gas. The electric light has its field and will maintain it, and so has the illuminating gas of the present day. The policy of furnishing electric light to their consumers when they demanded it has been pursued by many gas companies throughout the United States. I have always maintained that the term "gas company" was, and is at the present time especially, a misnomer. We should be called "artificial light companies;" and even if our consumers demanded from us a supply of oil, I do not know why we should not do so, if the operation was a profitable one. Apart from other considerations, I believe there are so many advantages in the use of electricity at the present day that the people will have it. I have no knowledge of any lamp, at the present time, that can be used successfully in the lighting of streets, that can be compared with the arc light of to-day, although I believe there are many gas lamps which will more than successfully compete and compare with the incandescent. When we pass through the streets and see, as we can in almost any city in our country to-day, the arc illumination that is being carried on, I contend that it is a benefit to mankind. The statement was once made, and I repeated it in our New England Association, that the Mayor of the city of Providence once said, "A city well lighted is more than half policed." I believe that statement; I know that it is strictly true. A few years ago, in your own good city, Mr. President, where (accidentally) I was thrown into the company of the Chief of Police, he stated to me, in speaking of this matter of electric lighting, that it was of vast benefit to the city of Boston; and that while he complimented—a compliment which I know was well deserved—the Company with which our worthy President is connected upon the pure quality of the light furnished by the Boston Company, yet he said that the public demanded the arc light for the purpose of lighting the crooked streets of that well-conducted city of Boston. I believe no gas company exists that cannot make use of the electric light, and successfully carry it forward. There is one matter which has been suggested to my mind in regard to gas companies. Undoubtedly many of you, gentlemen, have seen in the papers the account of a gas and electric light company in the little town of Spencer, Mass. Two weeks ago to-night I visited that town; and, gentlemen, I say to you it will well pay you to also visit it. Situated upon the hills, in the center of the State, it is one of the most beautiful places I ever visited, and I was well repaid for the hours I spent there. There they have three 15-horse power Otto gas engines driving 63 arc lights. I remained in the dynamo room for 25 minutes, and there was never a "wink" of an arc light. I started last night—or this morning, perhaps I had better say—from the Hoffman House, marching up Broadway, and there beheld those waves of light which Prof. Morton spoke to us about yesterday. They were more than waves; they were pronounced undulations. But that was not the fact with regard to the effect of the gas engines in the dynamo room in the town of Spencer. I must say I was more than surprised at the regularity and efficiency of these engines to run the dynamos. They claimed, I think, that there was economy in the use of gas at \$2 per thousand. In my investigation I did not take any man's statement, except in one particular—with regard to the consumption of gas per hour for running the dynamos I did take the statement of the gentleman in charge; but there were three large 50-light dry meters, one attached to each engine, and the three engines were directly connected with one line of shafting, and over that shafting was a belt to the dynamo. The consumption of gas would equal about 1,000 cubic feet per hour for the three engines. At a meeting of our New England Association a short time since, one of our engineers questioned the accuracy of the statement as to the consumption of gas. I believe that is pretty nearly what they claimed is the consumption of gas by a 15-horse power engine. I did not verify the statement by an inspection of the meter, because what I did see was so fully verified by what I had seen in the papers that I accepted their statement. My own experience, covering a period of three years, in running Otto engines of similar horse power, driving an exhauster to exhaust gas five miles from my works, has convinced me that their statement with regard to the consumption of gas was absolutely within the line. Now, if a 15-horse power gas engine can be run on 300 cubic feet (and it runs through my head that I have heard about gas being made at 5 cents per thousand), the possibility of the electric light lies in the possibility of gas companies to furnish the electric light at a very much reduced cost. The large number of electric light men who are getting into line, reminds me of the story of the Irishman at the democratic meeting. When the floor gave way, and they all went into the cellar excepting himself, he being left on the threshold, said, "By the Holy Moses, I will jump myself!" I am inclined to think that our good friend from Toronto, while still standing on the threshold, will yet go with the crowd.

The President—I think the Association would like to hear from

Mr. Nettleton on this subject, as he has also had some practical experience.

Mr. Nettleton—While Mr. Stiness was making his speech it occurred to me that the flickering of the light on Broadway was not due so much to the flickering *per se* as to the flickering in his eye. The Company with which I am connected went into the electric light business in November, 1885. We were one of the first, if not the first, companies in New England to take hold of it; and I said then, as I say now, if we had not made any money, but had merely covered expenses, I would still be glad that we entered the field. It seemed to me, in a town as small as ours, where the field for lighting was so narrow, that two companies could not live and do business. It ought to be done by one company. Since that time a town in Connecticut selling one-third the quantity of gas that we do, has had a competing electric company. The men who owned the electric light plant have pushed the business so strong that the Gas Company has felt very much like going out of business. That may be an exceptional case; but although they have never sold more than one-third the gas sold by our Company, they have a good many more electric lights than we have. It simply shows the difference between an electric light plant in a small place, operated by the gas company, pushed by consumers (because it is a competitive company) and pushed by people who feel that their existence depends upon pushing the business to the utmost possible limits, and an electric light plant operated by a gas company who simply run it to supply the demand which everywhere exists for electric lights. Now, as to the results. We run by water power, and for that power we have as yet paid only \$1,000 per year. The actual running expenses have been charged up to the account, also the small repairs which have been made so far, and nothing else. In starting, through the month of September, we had only 3 lamps, but shortly afterwards (in January) we secured a small street lamp contract. Up to the 1st of April following we had 33 or 34 lights; and we had lost, up to that time, \$275. For the following year, ending April, 1887, we ran from 33 lamps up to 64. We had at that time an investment of \$15,000, all told; and we had made on that investment only \$500—which is not very much. For the year ending April 1st, 1887, we only did a business of \$3,300. We have gained now so that we have to-day the equivalent, turning incandescent into arc lamps, of 90 arc lamps. We are doing business at the rate of over \$6,000 per year. The account at the present time stands on our side by considerably more than the whole of last year. Unless we meet with some accident or something which causes a large expenditure, we shall make on an investment which now stands at about \$20,000 not less than \$2,000; and it may run higher. The profits would increase proportionately as the business expanded, and be considerably larger than they are now. It is very much like the gas business. If you do but a small trade your income is eaten up by the expenses; if you do a somewhat larger business you make a little money; if you do a still larger business, then you make considerable money. That is very true of the electric light business. I shall not feel satisfied—shall not feel that the Company is whole, is being paid directly in money, until we shall have made 16 per cent. upon the capital actually invested. I do not think we have earned it at the present time. That 16 per cent. I would divide as follows: 6 per cent. for interest; 8 per cent. for depreciation; 2 per cent. for office expenses. When we reach that point I think I can safely say the Company is whole. But indirectly I feel that it has been one of the best investments the Company has ever made.

Mr. Helme—How much do you get for gas?

Mr. Nettleton—Last year \$1.71 was the average.

Mr. Neal—I will not enter into details as there is not time; but I will state that the Charlestown Gas Company which I represent entered into the supply of electric lighting on the 15th of September, 1886, and the business has been carried on, financially and practically, with great success. We furnish the arc light and also the incandescent. The incandescent is not the Edison, nor the alternating current, but the "individual cut-offs," as it is called. Each lamp has a regulator by itself. We have but one price for each arc light for commercial lighting, and one price for 8 incandescent lights for commercial lighting. We have a contract with the city for three years at a different price. We have no reason to regret having taken this step. I cannot give the figures that I would like to give, but the results are very satisfactory. I only wish a way was devised by which water gas, coal gas, and the electric current could be so combined as to send the whole through one burner to the customer.

Mr. Lansden—I would like to ask Mr. Nettleton whether or not the introduction, and what he has done with his electric light, has had any effect upon gas consumption? Whether his gas consumption has increased or decreased; and what amount in his profits he has charged up

to the superintendence of the works? Also, whether he has put it all on the gas company, or divided up the expense with the electric light company.

Mr. Nettleton—In answer, I will say that the consumption of gas is increasing slowly—not so rapidly as it did four or five years ago; but I think this is due largely to the fact that the town is not growing so rapidly as it did then. As I stated in my remarks, the expenses given were about the actual operating expenses. Nothing is charged off for my salary, or for office expenses; and nothing is charged for superintendence or collections as yet.

Mr. Monks—I would like to ask Mr. Nettleton whether he can do a larger electric light business without further expenditure; and how far he can go in that direction?

Mr. Nettleton—The plant consists of two 45-light and one 50-light dynamos, making a total of 140 lights.

Mr. Coggeshall—How many gas lights do these arc and incandescent lights displace?

Mr. Nettleton—I prefer to answer that question after dinner.

Mr. King—I desire to say a word or two in answer to Mr. Pearson. His experience with high-power burners has been entirely different from ours. I have put the electric light in stores and rooms which I tried to light by high-power burners, and the result has been eminently satisfactory to the parties using the electric light. The argument in favor of the electric light is this: When I used the high-power burners I had it on my mind all the time, if there was not a customer in the store, that I had the gas to attend to, and that I must shut up early and save gas, if there was no business. I had that on my mind all the time—the care of the burners. But since I have had the electric light I know that when I shut up and go home my store is illuminated brilliantly, my windows are nicely illuminated, and I have an advertisement there until 12 o'clock at night. I have to pay no attention to lighting or putting it out, and have no care whatever on my mind. The increase in the sales of gas has not only kept up with the average, but is about 2 per cent. more than the average. So far as the profits are concerned, we have reached what we hoped for, and 1 per cent. more, for the last year's business. As far as competition is concerned, I may say I care not who comes; for I claim that my advantages are such, as a gas man, that, with the advantages which I have enumerated in my paper, I certainly can compete and hold my own against anyone. As to depreciation, of course, with only something over two years' experience, we cannot judge what will be the proper charge to make; but I think that probably what Mr. Nettleton states (8 per cent.) would be fair. Our plant shows very little depreciation at this time, but of course we cannot tell what is in the future. It is high-speed machinery, and there must be more or less charged over to depreciation.

Mr. C. Nettleton—What price does Mr. King get for arc lights burning until 12 o'clock?

Mr. King—\$8 where there is one light, and for the hotel; \$6.25 for others.

Mr. Pearson—What is the price of gas?

Mr. King—Our price is from \$1.50 to \$2 per thousand, according to the amount of consumption.

Mr. Pearson—When you speak of \$6.25, it is for how long?

Mr. King—Until 12 o'clock at night; \$6.25 per month.

Mr. C. Nettleton—What price does Mr. Neal get, and how many hours does the light burn?

Mr. Neal—What we call commercial lights are now lighted at dark and turned off at 11 o'clock. We stop the current then. We charge 50 cents per night—that is, for the arc. If we give them 8 incandescent lights we charge 50 cents for those. We have in some cases put in incandescent lights in stores, or business places, where they never used any gas, but have always used kerosene oil; so that we are indirectly interfering with the Standard Oil Company.

Mr. Pearson—If the same energy had been put forth in introducing these high-power burners in opposition to the electric light as the electric light people put forth in introducing their burners in opposition to the gas companies, in many places the gas companies would succeed in defeating competition. I believe that, comparatively, a small cost and little effort would succeed in having them put in. Our experience, as I have stated, has been exactly the reverse of that of Mr. King.

The President—Mr. Pearson's situation is somewhat different from that of smaller companies. Most large companies can afford to wholly ignore the question of introducing arc lights, but the question of incandescent lighting is a very different matter.

Mr. Lowe—Does Mr. Neal use the incandescent on the arc light line?

Mr. Neal—I do.

Mr. Lowe—What system do you use?

Mr. Neal—The Brush.

On motion of Mr. Pearson, a vote of thanks was tendered to Mr. King for his paper.

COMMITTEE ON BADGES.

The President—The Chair will appoint as the Committee on Badges, according to the resolution, C. H. Nettleton, G. B. Neal, and S. G. Stiness. The Chair appoints those three gentlemen from the same locality, in order that they may confer together. I think it would be more convenient than to have them scattered about the country.

SECOND DAY—AFTERNOON SESSION.

COMMITTEE OF ARRANGEMENTS FOR TORONTO MEETING.

The President appointed as the Committee of Arrangements for the next meeting, at Toronto, Messrs. W. H. Pearson, of Toronto; J. S. Sriver, of Montreal; F. W. Gates, of Hamilton; G. A. Hyde, of Cleveland, Ohio, and Wm. Cartwright, of Rochester, N. Y.

Mr. C. W. Blodget, of Brooklyn, N. Y., here read his paper on—

THE COMPARATIVE ILLUMINATING POWER OF GAS PURIFIED WITH LIME VS. OXIDE OF IRON.

Something over a year ago the Company with which I am connected commenced to use Connelly & Co.'s iron sponge for purification. Being fully impressed with the fact, as laid down in all the text books, that carbonic acid was highly detrimental to the illuminating power of gas, and knowing that oxide of iron had no affinity for CO₂, it was deemed essential to bring the gas in contact with lime in order that the CO₂ might be eliminated; otherwise the benefits it was expected we would derive from the use of sponge would be more than lost through the depreciation of the illuminating power of the gas due to its presence.

To avoid such a contingency a layer of lime, 4½ inches deep, was spread on trays resting on the lowest offset in the purifying boxes, with the object of not only extracting the CO₂ but, in addition, to serve the purpose of arresting any particles of tarry nature which occasionally come over with the gas from the scrubbers, and preventing same from permeating the sponge, which rested on trays placed immediately over the lime.

With this arrangement of materials matters ran smoothly for about a month, when we commenced to find carbonic acid in the gas long before it would be necessary to change the purifiers on account of the oxide being fouled, although the latter was purifying but little more per bushel than formerly.

In accordance with the precepts this condition of affairs was not allowable, and consequently we adopted the (to us) novel programme of endeavoring to change the purifiers whenever CO₂ was shown to be present in the gas, without waiting for the sponge to show indications of being fouled with sulphur compounds; but this plan proved a flat failure, for we would find carbonic acid in the gas within two hours after changing.

Finding it impossible, by means of the plan adopted, to get rid of the objectionable visitor, and being loath to abandon the use of sponge, it was determined to discard the lime entirely, to substitute sawdust for the purpose of arresting any substances deleterious to the sponge from passing to it, and to ascertain from personal experience what would be the effect upon the illuminating power of the gas of allowing the carbonic acid, still present after leaving the scrubbers, to remain. As soon as this change was inaugurated the candle power was most carefully noted, and to our astonishment the quality of the gas was found to be fully equal to that which it was our custom to make.

In order to corroborate the candle power of the gas as determined by the bar photometer, we caused to be made and placed in the photometer room two small purifying boxes (20 in. by 20 in.), through which gas from the outlet of the scrubbers was passed to the bar to be tested. In these boxes was placed, respectively, lime and iron sponge to the depth of 12 inches, each containing the same amount of moisture they ordinarily had in our practical operations. We were then (supposedly) in a position to make a comparison of the candle power of gas with and without carbonic acid.

One important factor, however, had been overlooked—viz., the constantly varying character of the gas being made; and as some little time necessarily elapsed between the readings, the obtainment of accurate results was impossible.

Two governor burners, which upon test were proven to consume equal quantities of gas under varying pressures, were then placed on either end of the bar, and the luminosity of the two flames compared—the piping having been previously so arranged that the gas from each purifier could be passed to either burner at will; but as, for some unaccountable reason, the height of the two flames constantly varied, no dependence

could be placed upon the observations. Further experiments were (owing to press of business) abandoned until last month, when the matter was again taken up.

A second experimental meter was procured, each purifier connected with one, a "Bray Special, No. 7" burner put on each end of the bar, and pressure gauges placed before the inlet of the meters.

The separately purified gas was passed to each meter at one inch pressure, when it was found that each burner consumed exactly six cubic feet per hour.

A comparison of the illumination of the two lights, one against the other, showed them to be equal; for although each gas was repeatedly switched from one end of the bar to the other the disk remained in the center. This would seem to verify beyond the shadow of a doubt that the illuminating power of gas purified with oxide of iron was as great as that purified with lime, and to fully substantiate

It will be observed that while the sponge gas contains 2.19 per cent. of CO₂ it has also .49 per cent. more illuminants than was found in the gas purified with lime, which fully accounts, I believe, for the fact that the illuminating power of gas thus separately treated as to purification was found to be equal.

Discussion.

Mr. McMillin—It gives me much pleasure to listen to papers of this character, for two reasons: first, because of its eminently practical nature, and, secondly, from its substantiation of views advocated by me at some risk to my reputation as an engineer. For many years I have contended that gas purified by oxide of iron was as good as that purified with lime alone. I had supposed that gas purified with a little lime and a great deal of oxide of iron would be better. That point, however, I never determined. All the analyses I ever made demonstrated that there was a higher per cent. of illuminants in gas purified with oxide of iron alone. I have made no analyses recently, and cannot give results. While Mr. Blodget's paper only shows one-half of one per cent. of illuminants, it is nearly

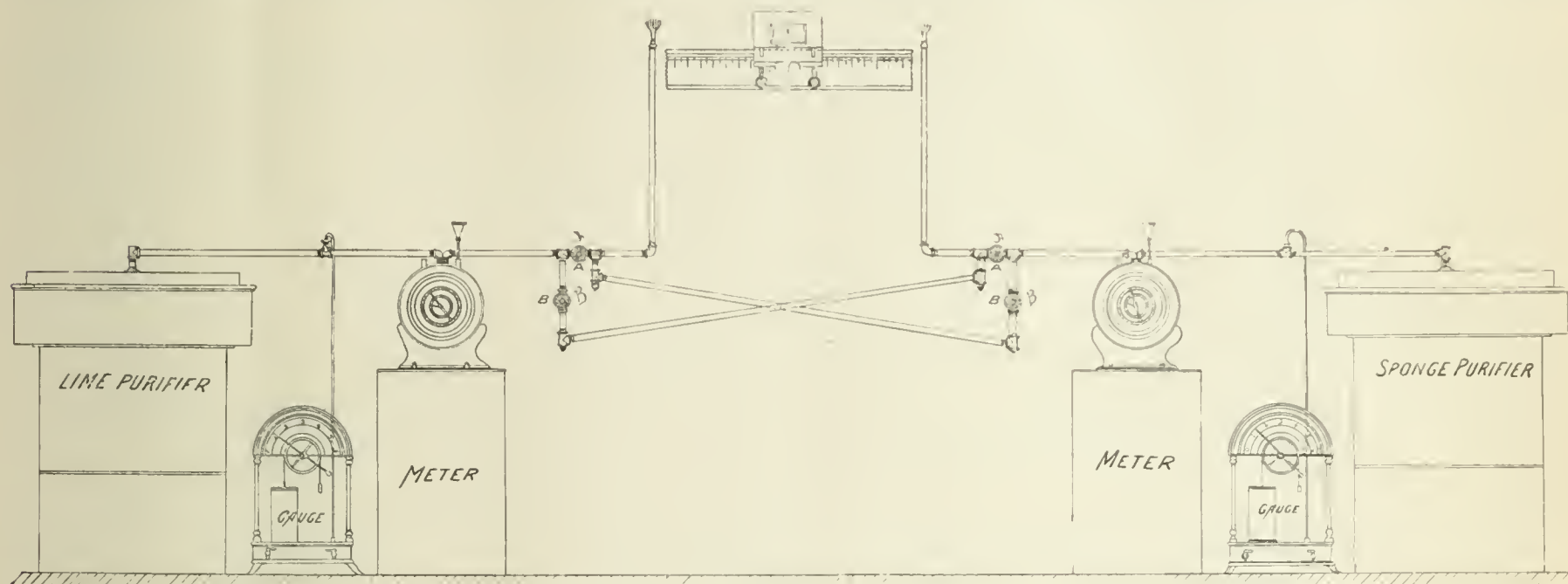

the correctness of the candle power of the commercial gas, as observed daily.

The average results obtained during eight months' practical operations, with lime as against iron sponge, are as follows:

	Make, per pound.	Candle power.	Candle feet.	Per cent. of cannel used.	Candle feet for each per cent. of cannel used.
Lime gas (CO ₂ not present) ...	4.94	18.6	91.9	9.64	9.53
Sponge gas (CO ₂ present).....	4.9	19.	93.1	9.64	9.65

Admittedly, carbonic acid is detrimental to the illuminating power of gas in which it is present. How, then, are we to account for the fact, demonstrated day after day for months, and verified by the experiment above mentioned, that gas (made in both instances from the same coals) containing an average of two per cent. CO₂ is equal to that from which this deleterious has been eliminated?

It was suggested to me that the cause for this apparent paradox might be found to be due to the fact that the lime robbed the gas of some of the hydrocarbons which the oxide of iron allowed to remain, and that the increased percentage of illuminants contained in gas purified with the latter material equalized the baneful effects of the CO₂.

To determine whether this was a fact I arranged to have thorough analyses made of the lime and sponge gas, so to speak, by the Bunsen method, the results of which are here given:

	Lime.	Sponge.
Hydrogen.....	48.92	47.33
Carbonic oxide.....	6.02	5.84
Carbonic acid.....	.00	2.19
Marsh gas.....	36.86	36.05
Illuminants.....	5.65	6.14
Oxygen.....	.12	.09
Nitrogen.....	2.43	2.36
Total.....	100.00	100.00

equal to an increase of 10 per cent., there being but little more than 5 per cent. of illuminants in the lime gas, and a little more than 6 in the other. Really it shows about 10 per cent. of increase of illuminants. Some years ago I made an experiment in retorting my lime—the lime had been used for some time—to determine whether there was anything absorbed by the lime that would make light. It was mixed with coke screenings, which would probably make a difference in the quantity of gas to be made—not because there was gas in the coke, but because from the moisture present in it we might get a little water gas. I made from lime taken from the bottom purifier, which had been in use ten days, 1.85 feet per pound of 13-candle gas. Necessarily some illuminants must have been taken from the gas before you could get any such result as that. I would not advise you to use it as regular provender for making gas; but, unquestionably, the lime does absorb a great deal of illuminants.

The President—Was there any tar in that lime?

Mr. McMillin—Not noticeably. I will say that, before the gas reached the lime, and in addition to the ordinary scrubbing it had received, it went through three feet of coke screenings, used in the old purifiers that were to be abandoned, but that were still in position; hence it would have been impossible for much tar to have accumulated. I would have supposed that the quantity came rather from the coke moisture. The illuminants came, of course, from the illuminants absorbed by the lime.

The President—We have another paper on a kindred subject to be read, and I think it would be better to read it at this time, and have the two papers discussed together.

No objection being offered, Mr. Thos. Turner, of Charleston, S. C., read his paper on

PURIFICATION PUZZLES.

Mr. President and Gentlemen of the Association:—Our worthy Secretary, who is indefatigable in his pursuit of literary matter for our meetings, requested me to prepare a paper on "Purification with Iron Sponge," forgetting, I suppose, that I have been fully occupied in recovering and repairing damages from a bad attack of the "shakes." In consequence I feared I would not be able to do justice to the subject. However, I therefore submit the following on "Three Purification Puzzles," hence the title:

I do not know that there is anything unique about them, as some of you may have had similar experiences; but still I think they will promote discussion, and probably develop some information which may be of benefit to all of us.

A description of our condensing, scrubbing and purifying arrange-

ments is as follows: A Pelouze and Audouin condenser, 27 feet from take-off of the hydraulic main; 300 feet of 12-inch main, partly under floor of retort-house, an 8-inch air condenser, in 4 rows, 18 feet high, about 1,000 feet of 8-inch pipe; a scrubber 19 ins. by 5 ft. 6 ins., filled with wooden trays; a second scrubber, 15 ins. by 4 ft. 4 ins., filled with wooden laths set on edge; and 4 purifiers 12 ft. by 8 ft., by 2 ft. 6 ins., with dry center-valve and 12-inch connections. The purifying surface is, quite evidently, too limited for a manufacture of 200,000 or 300,000 cu. ft. per diem.

For years we worked with dry lime, in the usual manner, that is, 4 or 5 trays with lime about 2 1-2 inches in depth and mixed so as to ball in the hand without staining. As our manufacture increased we found the increase of pressure so great that, at times, it was sufficient to unseat the inlet to dry center-valve and blow out the water lute to boxes. In addition to this we were frequently compelled to change two and three purifiers per day. It had been recommended to our Board that we should increase the capacity of our purifiers; but before acting on the matter we received a welcome boon, in the shape of Mr. Theobald Forstall's paper* on "Lime Purification," read at our meeting in Washington, in May, 1875.

This mode of preparing lime was immediately put into effect, proceeding cautiously in the use of water. This did very well, purifying from five to six thousand cu. ft. per bushel of hydrate of lime, and even as high as 8,000 cu. ft., whereupon we were tempted to cry "Eureka"—when the process suddenly collapsed, and gave us Puzzle No. I.

Box after box was changed, but the gas seemed to run right through the lime without its scarcely taking effect; in fact we were purifying not more than 1,200 cu. ft. per bushel. The lime came out of purifiers almost unstained, and, after a few days' exposure to the atmosphere, seemed to regain its original purity. For a week we were compelled to change box after box—sometimes two, and even three in a day. There seemed to be no remedy for this state of things, but when we tried the experiment of putting in a drier charge of lime the evil ceased at once.

From this time we worked along very comfortably, purifying between six and seven thousand cu. ft. per bushel of hydrate of lime, when we were suddenly confronted with what I call Puzzle No. II.

At home one evening I took a match to light the gas, and, as sometimes happens, the match went out before the gas was ignited. The tap meanwhile being open my attention was attracted by the peculiar smell of the gas, and, on applying the nitrate of silver test, I discovered a considerable trace of SH. A hurried visit to the works and a test of the purifiers showed everything to be correct, but the gas coming from the station meter showed a strong trace of H₂S. The center-seal and connections were next examined, and all seemed to be in perfect order. On the next change of purifiers the trouble disappeared, only to return again in a few days; and so it continued, on and off, for weeks, much to my annoyance, during which time every conceivable thing was tried to find out the difficulty.

The disease after all was very simple, and the remedy applied was equally simple though effective. It appeared that the water used to seal the bottom of the center-seal had become super-saturated with SH, and as the clean gas passed out over the surface of this water it took SH in sufficient quantities to produce a very decided stain, when the usual test was applied. The remedy was a simple washing out of bottom of center-seal once or twice a week, and we had no further trouble. And here, let me say, I think it is a wise precaution to occasionally test the gas at the station meter.

In October, 1884, after various vicissitudes with dry lime, owing to the large manufacture on the limited surface for purification, we decided to try the experiment of using iron sponge with the hope of reducing the resistance in the purifiers. We were somewhat disappointed for several weeks, but eventually succeeded in working satisfactorily, or, with a manufacture of 280,000 cu. ft. per diem passing through our small boxes, and with about 3 inches back pressure, we were purifying 9,000 cu. ft. per bushel of sponge. From some unaccountable reason we afterward began to have trouble from sudden increases of pressure in purifiers, and from the rapid changes to reduce the pressure, our results fell off 50 per cent., and, eventually, 66 per cent. This was simply from increased pressure—the sponge not being fouled in the least; and yet we would make a complete round of changes in 24 hours.

From the prevailing state of things we got the impression that the material was in too finely a divided condition, and so absorbed moisture from the gas and clogged the screens, as it seemed to form

into a pasty mass right at the screen. With this idea, earthenware pans, containing SHO, were placed in bottom of boxes to absorb moisture, and shavings, sawdust, gunny-bags and breeze were placed on an extra screen; but all to no good result. As a last resort a letter was sent on to the Messrs. Connelly—for of course (?) the fault could lie nowhere else than in the material—whereupon they suggested the addition of sawdust to the material. However, in the interval of receiving their reply, Puzzle No. III. had been solved. The remedy applied was simply by-passing the Pelouze and Audouin condenser for a few hours, and keeping the purifiers at a slightly higher temperature. It was the same old bugbear of the gas manager, viz., naphthaline, although it was not readily perceptible among the sponge.

Now, the query is, "Was this over-condensation?" Does the P. & A. condenser, under certain conditions, when removing the tar carry along with it too many of the light hydrocarbons, rendering the gas more liable to deposit naphthaline on any sudden change of temperature?

Notwithstanding an occasional drawback from the causes above mentioned, we are still using iron sponge; and, under these very disadvantageous circumstances, our present lot has purified about 122,000 M. cu. ft.

If the above will aid some brother gas manager in avoiding such annoyances—which, at the time of their occurrence, were serious matters to us—the purpose of this paper will have been fully answered.

The

Joint Discussion

was then proceeded with.

Mr. Graeff—I would like to ask Mr. Blodget what kind of photometer he used in making those tests?

Mr. Blodget—I stated that I used a bar photometer.

The Secretary—Experiments are sometimes funny things. I made just about the same series of experiments on the effect of carbonic acid that Mr. Blodget did. I took a small purifier in the photometer room, and, taking gas which had merely passed through iron at the works, I first tested it directly at the bar, and then passed it through the small lime purifier. I made a long series of experiments, but I can very quickly summarize them. The gas was analyzed, and as it came into the office (the tests were made at our office a couple of miles from the works), it contained 1.32 per cent. of carbonic acid, but when passed through the lime purifier it showed no carbonic acid. The loss of light in not passing the gas through the lime purifier, through a long series of experiments, was .8 of candle power on the argand burner, and 1.03 of candle power for the flat flame burner. Those results are just the opposite of Mr. Blodget's.

Mr. Boardman—I wish to ask Mr. Humphreys if the gas which, after passing through lime, gave him better results, had not also passed through iron sponge?

Mr. Humphreys—Yes.

Mr. Boardman—Therefore, I think it does not touch the point under discussion now. I understood Mr. Blodget to say that he tried lime alone, and sponge alone. He does not say in his paper, and I do not think he would say, after he had purified with sponge, and had passed the gas through a layer of lime, but what the gas would show higher candle power than it did after going through the sponge alone. As I understood his paper, he means that the sponge alone, or the lime used alone, gave him the same results.

Mr. Blodget—Exactly.

Mr. Boardman—I do not think there can be much doubt as to the benefit of passing the gas through a thin layer of lime after it has passed through the sponge, to take out its carbonic acid, but not to take out the illuminants.

Mr. McMillin—I have had similar experience to two of the "puzzles" of Mr. Turner,—that of foul gas getting into the holder, although pure in the purifying house. We have had it so on several occasions. I heard of his success in cleaning out his center-seal, still, I could hardly believe that that was the difficulty, without any increase of temperature, or that the sulphuretted hydrogen would pass off in such a quantity as to make the gas foul; yet I naturally tried it, knowing that it had succeeded with him. I derived no benefit from it. I could never get the same results. After some time, I discovered that one chamber of the center-seal would occasionally leak, and it would continue to leak. When I changed off from it the trouble ceased, but when I next got round to it the same difficulty would appear. We would be obliged, while on that section, to run the gas into the holder by itself, and let that be used in the day-time for cooking, or for leaking in the streets, and turn the other on at night during the burning hours. Of course we ground our center-seal all we could. After a while it stopped. We have been troubled for two or three weeks at a time, once or twice a year, for two or more years. With "Puzzle No. 3" we had difficulties last winter. From October, 1885, to March, 1886, we never changed the purifier because the oxide was foul, but always on account of the pressure. I am almost afraid to tell you that I have measured the naphthaline on the top of the outlet pipe of the box, five and a half inches deep; and, for weeks at a time, when I would

*See JOURNAL, June 16, 1875, p. 223.

lift the lid, the entire surface of the oxide would be covered so that you could not see any of it. It was not surprising we had back pressure with that much naphthaline. It was better, however, to have it through the works than to have it in the services about the city. We were having no trouble there. But, in March, 1886, I put in a lower layer, a tray of all coke, then another tray of half coke and half oxide of iron, and then a couple of feet of pure oxide of iron on top of that, but received no relief. I have recommended that medicine to all my friends who have been afflicted, and am prepared to take it myself. Two months ago, after we had been running along for some time, changing the box once a week or ten days, our pressure suddenly began to run up. We naturally concluded that it was the old trouble, but when we changed the boxes we saw no sign of naphthaline on top of them—not a particle. We examined all the boxes, took out the coke, put in fresh material, fixed everything in good shape, and ran 24 hours, and then changed again. Then we mixed in new sawdust. We had been running on that oxide for some time. We made the oxide nearly one-half sawdust, but without helping it one iota. It was a box which we changed every day, because of the pressure. We had continued that up to the time I left home. I left home with some misgivings. We started in just before I left home, to put on three inches of coke screenings in the second tray, and oxide on top of that. I have had two or three telegrams from home since my arrival here, and the pressure has not increased any. The surprising thing was that no naphthaline passed out; although the pressure would go from three-fourths of an inch on each of the second and third boxes, and an inch or an inch and a half on the first, up to 10, 12, or 14 inches, sometimes in an hour. Very seldom it happened that more than three hours from the time the pressure began to show an abnormal condition of affairs, we did not have to change. There was no naphthaline in sight, yet we were satisfied that naphthaline was what was the matter. My friend, Turner, remedied his difficulty by cutting out the P. & A. condenser. I have sufficient condensing and scrubbing capacity; and we cooled our gases down as low as 58° and 60° during the cool weather that we had, and we ran it as high as 125. We by-passed the half of our scrubber in the condensation; then we by-passed all of it, and ran the gases into the boxes hot, without being either washed or scrubbed. I ran steam, at a pressure of 60 pounds, through a 3-4 inch pipe, for four hours, when the pipe became so hot that you could not bear your hand upon it, but not an iota of relief was granted.

The President—I think a French philosopher has said there was something in the misfortunes of our friends that always caused us pleasure. I think if we once begin to take the experience of the members of this Association we shall have business enough to occupy us for the whole of our session, without doing anything else. I think Mr. McMillin, when he sat down, meant to move a vote of thanks to both of these gentlemen; and I take great pleasure in putting the motion. [Adopted.]

Mr. Richard J. Monks, of Boston, Mass., read a paper entitled, **DISADVANTAGES OCCASIONED BY FLUCTUATIONS OF CANDLE POWER IN GAS FURNISHED TO CONSUMERS.**

The practical and scientific advance made in the manufacture of illuminating gas since its first introduction, has resulted in a double advantage to the consumer—while he pays a less price he gets a much better light. That the light averages much better than of old is easily demonstrated; and while the average of your candle power is an important point, the uniformity is an essential one.

It is certainly true that so delicate and sensitive an organ as the eye acquires a strong habit in favor of uniformity in the volume of artificial light. Now, if your eyes find the volume of light uniform, the satisfaction this affords you reduces your disposition to complain of the light furnished.

In glancing over the history of our industry, the standard of illuminating power adopted a quarter of a century ago seems absurdly low; and this fact illustrates how comparison so often becomes the basis of our judgment, and how necessary it is that unfavorable comparisons as to the article we furnish should not prevail among our consumers.

Step by step we have advanced from being content to produce a twelve or fourteen candle gas, and while we have been educating ourselves to produce a superior light we have been educating the community to call for and require it. The older members of this Association can recall how, step by step, this process went on. Your modern consumer knows nothing about all this, and he cares less, but argues thus:—Your gas is poor to-day, because it is not so good as it was yesterday.

Suppose you assert that to-morrow you will please him, and, if your gas was "off" two candles, you put it up four. You are then like the milkman giving an unusual amount of cream to his customer; you must keep right on, for the moment you return to your normal standard you are denounced; and, should you happen to again get below it, you add to the general dissatisfaction.

It may be argued that such fluctuations as this are extreme, and unusual; and certainly the truer this argument is in any case the

better for the company, although it may be said that occasionally men are put in charge of gas works whose frequent experiments amount to a tinkering with the quality of gas sent out.

Gas carefully made by any of the leading processes, when consumed, will produce a light which, for uniformity in candle power, will take front rank and can be kept within a very close range.

It will not be so brilliant as an electric arc, but it will not indulge in those light-giving gymnastics, which are sometimes observed in arc lighting. It will also surpass the incandescent light, not in steadiness of flame, but in uniform intensity.

This is a strong hold we still have over our modern competitor—electricity; and we ought to work it for all it is worth.

In the matter of how much light can be got out of a given quantity of gas, due allowance being made for the material and the process used, many gas men are now agreed, and endeavor to live up to the modern standard and keep close to it at all times.

Let us briefly consider some of the causes which tend to interfere with this.

Defective construction in some part or parts of our machinery; lack of vigilance in frequent examinations of the photometer; dead ends on mains where little gas is used; experiments carelessly carried on; and the mingling of different gases at irregular times and in irregular quantities. During the year, since we last met, a case was brought to my attention where a new process had been introduced. The superintendent told me that the gas produced had varied from six to 30 candles, and had made lots of trouble among consumers.

In another case the gas furnished at times was all coal gas, at other times all water gas, and sometimes was part one kind and part another. It seemed to me that the trouble this latter company experienced with its consumers was largely owing to this cause.

The rustic who comes to the city for the first time, born and bred far from the "maddening crowd," and accustomed to a tallow candle or a cheap kerosene lamp, is dazzled and almost blinded by the brilliancy of a modern lighted city. The quantity of light is so unusual that he makes no account of any lack of uniformity.

Your city man, on the contrary, is a critic, and a severe one, when he deals with gas matters.

He will give you a rap whenever he can through your collectors or the daily press. Praise he will never bestow upon you; but good gas, of uniform quality, will be least liable to his censure.

Having finished reading his paper, the author thus continued—

My time was limited for preparing this paper, and I would like to explain at greater length the comparison I made with regard to gas and electric light. It seems to me to be a fact that we are able to keep our gas within closer range of candle power than any other known substance used for lighting. The gentlemen present who attended a lecture* given by President Morton at the Stevens Institute, Hoboken, N. J., before this Association some years ago, will remember the beautiful illustration he gave us by throwing the arc light upon the stereopticon, which made it very apparent why this unsteadiness of the arc light exists, and I do not know it has been entirely remedied. The defects that an electric engineer must overcome in order to keep his candle power steady, as I understand them, are not only the volume of electricity, but the intensity that is furnished to any given lamp. It is also a fact that the particles of carbon, as they are burned, are torn off irregularly from the carbon pencil. In the illustration given by President Morton the ends of those carbons were extremely beautiful. They had the appearance of the top of a mountain covered with snow. As the light played from side to side it would appear like a mountain on one side, all shaded, but the shadow would pass to the other side, showing that these particles of carbon were being torn off at frequent intervals. In the incandescent light the trouble seems to be of a different character. Of course, the question still arises as to the quantity of electricity required to produce the light, and the intensity. The trouble that I have observed in all companies that I am connected with (notably at Woburn, Massachusetts) is that the lamp itself degenerates. We do not observe this in a great city like New York; and there are two or three reasons why we do not observe it here. One reason is that all the apparatus used for the purpose of producing incandescent light is new, and the various manufacturers are naturally very ambitious and anxious that their light shall make a good show here so that they may introduce it elsewhere. There is another reason—they can employ special electrical talent here; and it does not so much matter to them here what the light costs. In

*See JOURNAL, Jan. 2 and 16, and Feb. 3 and 17, 1879.

order to get at what the incandescent light will do on the average, you must go to some small place, like Woburn, for instance, which is still a town, although it aspires to be a city. There we find in practice that the electric light company, which is competing with the gas company, is offering to supply electric light to any store at the price of gas. The first lamps they put in give a 20-candle light, which is better than our gas light, the latter averaging from 16 1-2 to 17 candles. But the character of that electric light gradually degenerates, until it gets down to 8 or 10 candles; and there it stays. That amounts to a serious fluctuation in the long run, and is a matter which, in the hands of outside companies (not gas companies, who have studied this subject in the way of looking after their consumers and rectifying evils) amounts to an evil sure in the long run to be very vexatious. If you will take the readings of your photometer often enough, after your gas is ready to go into the holder, and see to it that your consumers are not using worn-out and wasteful burners—a matter that every company ought to look after—then I make the claim that, month after month, and year after year, we have, in gas, a more uniform lighting value than can be shown in any other known method of artificial illumination.

On motion of Mr. King a vote of thanks was tendered Mr. Monks.

The President—As the next two papers to be read are on kindred subjects we will hear them both read before we discuss them.

Mr. O. B. Weber, of New York city, read his paper entitled :

DEVELOPMENT OF THE HALF-DEPTH REGENERATIVE FURNACE, AND SOME OF THE RESULTS.

Firing retort benches with gaseous fuel has occupied the attention of the gas world for the past 25 years. As practical results of these labors the various regenerative systems show how much ingenuity and scientific learning has been expended. The first attempt to fire with a regenerative adjustment in this country was made at the 42nd Street Station of the Consolidated Gas Company, New York city (known then as the Metropolitan Gas Works), and was due to the progressive and enthusiastic ideas of the President, Mr. O. Zollikoffer. The form of furnace used was the Liegel, or Slit, which enjoyed at that time the privilege of being the first regenerative furnace tried in this country. This system, through the untiring and zealous devotion of the late Mr. Herzog, the engineer of the works, after several alterations, made necessary by the difference in the fluxing quality of European and American coke, has maintained itself at these works with great success. The next departure was the substitution of a grate furnace for the slot, suggested by Mr. Alexander Strecker, engineer of the works at that time. This change showed conclusively that, as far as this country was concerned, the most successful furnace would be one with a grate. This was the turning point in the use of this system. It became apparent now, through the successful operation of these furnaces that, if not too costly in construction and elaborate, nor requiring any more than ordinary care to run them, they would become valuable adjuncts to small gas works. It seemed a comparatively easy matter to translate a Liegel furnace to any gas works in the country. In one's mind, perhaps, this was so; but, practically, alas! What insurmountable and fearful obstacles were in the way! My friend, Mr. Baxter, had low retort houses and chimneys; Mr. Sherman was not able to excavate any distance below, owing to attraction of the waters of the Sound; another well-known gentleman discovered an iron spring bubbling forth in one of his arches, after digging down a few inches below the floor-line, and so I might multiply the cases, almost *ad infinitum*. It was all very well to speak of raised iron floors and charging platforms; but fate, in the shape of a stern Board of Directors, often withheld its sanction, scared by the increased cost of building. It was necessary in order to obtain the advantage of regenerative firing, to construct a furnace possessing all the cardinal features of the large one, without its elaboration or depth. Opportunity soon offered itself, through Mr. A. C. Wood, of Syracuse, N. Y. The half-depth furnace placed in his works was the first trial of this system. It possessed all the features of a large furnace together with its weak points. The air for primary combustion was taken in directly under the grate bars, without previous warming. The height of the combustion chamber was very small, so that scarcely any very important results could have been looked for from it. Still, it served as a guide; and subsequent trials show that the lines of construction as laid down in that furnace were correct and permanent. The practical application, now, of this system on a larger scale—*i. e.*, under many benches in one stack—was made at the works of the

Williamsburgh Gas Light Company, Williamsburgh, N. Y. The enterprise of Mr. C. W. Blodget made this trial possible. A stack containing 20 benches of six retorts each was erected. The details of this plant may interest the gentlemen of the Association. To begin with. The depth below the floor-line is 30 inches. The arches are 7' 6" wide, and 10' long, accommodating retorts 14"x28"x10'. The benches are built back to back, and the draught for them is furnished by one main flue running below the entire length of the stack to a chimney 75 feet in height. This does away altogether with the chimneys on each bench, affording a steady and uniform pressure on each bench. It will be assumed, naturally, in working regenerative furnaces all that is to be done is to fill and light the furnace, then charge the retorts and expect 9,000 to 10,000 cubic feet yield. This is all very nice; but it takes a little persuasion to secure this. Before getting there, however, make up your mind that it will not all be easy work. The presence of clinker, hard enough to build houses on, soon manifests itself. An increased consumption of coke surprises and alarms you. To make matters worse the heats, of whose uniformity and regularity you have been led to expect so much, go down, so that hardly 200 lbs. of coal can be carbonized. Speculations as to the probable cause are numerous, and pet theories are manufactured to suit the case.

Experience similar to this has been frequent, but the causes producing such effects have been discovered, as well as the way to avoid them. In the first place, the passage of the products of combustion through the parallel flues to the chimney is at times interrupted by a hard metallic clinker depositing itself in the last flue. Why it should remain there is obvious; carried around in a highly heated condition, the infusible particles of the coke are in suspension until the vertical, or chimney-flue is reached. Then their specific gravity prevents them from ascending; and, gathering additional volume, soon the most beautiful and exasperating clinker ever seen is formed. To obviate this becomes, then, a prime necessity. This is partially accomplished by heating the primary air supply, as well as permitting it to come to the grate-bars at ordinary pressure. An important feature, also, is the draught on the bench. There must be no rush of air, either primary or secondary; but all of it must go in easily and naturally. In fact, the damper on the bench chimney should not be opened any wider than to insure an easy but constant draught. Since the time this fact was established clinker has troubled us but little. The relation of the supplementary air supply to the primary oftentimes is a perplexing factor to the men in the retort house, or until they have become accustomed to the working of the furnace. It is a safe rule when employing an ordinary bench chimney furnishing through draught, to open the primary air supplies all the way and the secondaries about half. The area of each slide is 25 square inches. When the furnace is once in working order the men in the retort house find no difficulty in running it successfully. At first, they generally express some doubt as to the ability of the furnace, but when they see that it lessens their labor, besides doing away in a great measure with stopped standpipes, there is a rush for the position of fireman. In small works, with an output of only 20,000 cu. ft. per day, the saving of labor to the man in charge is quite a factor. The uniformity of the heats carried, and the comparative ease with which the furnace can be run, invite inspection. The percentage of the saving in coke is much higher than expected, and the average yield per mouthpiece compares favorably with the average results of the deep furnaces. I am indebted to Mr. Blodget of the Williamsburgh Gas Light Company for some of his results obtained during this season's run. In retorts, 14"x28"x10', charges averaging from 280 to 300 lbs. have been burned off every four hours, with an expenditure of about 25 per cent. of the coke made, figuring 40 bushels to a ton. The general averages of the various furnaces in other cities show, besides the marked saving in coke, an increased output per mouthpiece, as well as decrease in the wear and tear of the furnace and retorts. If, perhaps, the half-depth furnace as at present built does not pave the way to "Dollar Gas," it is not the fault of its economizing qualities.

Mr. Fred Bredel, of New York city, then followed with a paper on

THE ADVANTAGES OF REGENERATIVE FURNACES FOR LARGE AND SMALL GAS WORKS.

Gentlemen of the Association:—Every gas engineer will admit, in a general way, the advantages of regenerative furnaces, but my present purpose is to show to you in a specific way the financial advantages secured by their use. Take, for example, the case of a

large gas works, in which the retort-house is fired under the old system, and that the plant is still in good or perfect working order. To replace it with the improved style of furnace would cause, say, a total loss of that which it succeeded. Assuming that to be so, and the maximum production to be estimated at 1,300,000 per diem, with the total annual output fixed at 300,000,000 cu. ft., such a condition of things would call for a retort-house containing 14 benches of 9's, the cost of which would be about \$84,000. At the start, then, we are obliged to charge \$5,040—\$84,000, at 6 per cent. per annum—to interest account. Now, we could carbonize 60,000,000 lbs. (30,000 net tons) of coal per annum, and have left for sale, at the rate of 1,080 lbs. coke per ton of coal carbonized, 32,400,000 lbs., or (at 40 lbs. per bushel) 810,000 bushels of coke. Under the old system we would not be able to sell more than 700 lbs., or about 17 1-2 bushels, of coke per ton of coal carbonized, or a total of 525,000 bushels. This shows a gain in available coke production of 285,000 bushels. Assuming that the coke is worth only 4 1-2 cents per bushel, the net gain in money is shown to be \$12,825.

When using regenerative furnaces one man can make from 30,000 to 32,000 cu. ft. of gas per day, besides bringing in the coal, charging the retorts, attending to the fires, and removing and quenching the coke. This man's services would cost you upon an average, say, \$2.75 per day, hence the retort-house labor would figure out at about 8.6 cents per 1,000 cu. ft. On the other hand, in the retort-house fitted with benches of 5 or 6 retorts, fired under the old plan, one man generally makes from 18,000 to 20,000 cu. ft. of gas per day, and also attends to the other duties above-mentioned. At the same rate of wages, therefore, the charge for labor would be about 13.75 cents per 1,000 cu. ft., which shows a gain secured in this item for the improved plan of 5.15 cents per 1,000, equivalent (on the total make of 300,000,000) to the sum of \$15,450. Add to the latter the gain of \$12,825 from coke sales and we have a total of \$28,275, from which we must deduct the interest charge to arrive at the net profit, which figures out at \$23,235 per year. In reality when a new improved retort-house is to be constructed with a view to increasing the capacity of the plant, or for an entirely new works also, necessarily the cost would be \$84,000, *minus* the cost of a similar house fitted with 30 free-fired benches of 6's, which latter cost would amount to about \$60,000, thus showing that actually interest ought only to be charged on the difference, or but \$24,000.

Now, as to the other advantages, prominent among which is the greater regularity which can be maintained in the working of regenerative benches. You can at all times adjust them to the required make of gas, and you are independent of skilled firemen. The capacity can be increased at will, in about 2 hours, from say 9 to 10 thousand cu. ft. of gas per retort per diem; or, on the contrary, can be diminished from 9 to 8 thousand cu. ft. in the same space of time. A greater yield per pound of coal is secured; the life of the retorts is lengthened, and the cost of their replacement is about 20 per cent. less than in that of ordinary benches—capacity, of course, being duly considered. A pronounced advantage, especially in large cities where ground is expensive, is the gain in increased producing capacity per square foot, which may be stated at from 35 to 50 per cent. over the old style.

Let us next take the case of a small gas works having, say, a maximum capacity of from 60 to 70 thousand cu. ft. per day, with a minimum of about 30,000, and a total capacity of 15 millions cu. ft. per year, the coal carbonized amounting to about 1,500 tons per annum. In such works a regenerative bench of 8's, with a reserve bench of 5's, would be ample for the purpose. These could be put in at a cost of about \$6,000, entailing an interest charge of \$360. Assuming that 26 bushels of coke (40 lbs. to bushel) were left for sale from each ton of coal carbonized, a total of 39,000 bushels could be disposed of. Under the old firing system the coke available for sale would not exceed 24,000 bushels. We thus secure a net gain of 15,000 bushels, which, at 6 cents per bushel, shows a profit in money of \$900 per annum. The savings in labor would approximate to the services of one man for 365 days, plus the services of one day and one night man, each on 200 days of the year, or a total of 765 days. This, at \$2 per diem, means a saving of \$1,530 per year. Add thereto the money gain in value of coke sold (\$900), subtract therefrom the interest charge (\$360), and we have a net gain of \$2,075 per annum.

The benches could be worked in the following manner. Use a bench of 8's all the year round. In the winter season charge 300 lbs. per retort every 4 hours, or 1,800 lbs. per retort, or 14,400 lbs. per bench in the 24 hours, giving a yield of, say, 70,000 cu. ft. When the consumption is about 60,000 cu. ft. charge the same quantity

5 times in the 24 hours. That can be done by simply shutting off the dampers and keeping the heats down. The yield per pound of coal will be exactly the same, and the consumption of fuel proportionately less.

When sending out only 30,000 cu. ft. per 24 hours but one day and one night man would be required. The retorts having been charged, at 6 p.m., with 200 lbs. of coal, that charge could be drawn at midnight, and the retorts again refilled, the operation being repeated at 5:30 a.m. At that hour the night man, having filled the generator and closed the dampers, can go to his home. He is followed by the day man who tends to the necessary work around the purifying house and the yard, sells the coke, and draws the last charge, the latter will be burned off by, say, 5 p.m., and opens the dampers. At 6 o'clock the bench will again be ready for firing. The consumption of fuel during this time ought never to exceed from 3 to 4 bushels.

Joint Discussion.

The President—We have been interested in this matter now for a considerable length of time, and are beginning to get some results which are reliable. The Association would like to hear from Mr. A. C. Wood, as to whether his furnaces have worked as well during the past year as they did before.

Mr. A. C. Wood—I believe I have nothing to add to, or to take from, the previous statement made to the Association with regard to the working at Syracuse of the Stedman-Stanley furnace. It has continued to give us satisfaction, and perhaps we may report an improvement on the reports previously given. As to labor, our experience therewith holds good as to any previous statements. We have improved somewhat in the item of fuel. The ease with which the production can be increased and diminished is a very great advantage. At times of unusually dark weather, contrariwise, in bright weather, we can vary the production of those benches of 6's from 40 to 60 thousand feet (perhaps more than that if we desire) with very great ease, by increasing the draught, increasing the amount of coke in the furnace, and the charges in the retorts.

Mr. Sherman—We would like to have the experience of our President in the use of the regenerative furnace.

The President—My experience was given you, to some extent, in the address read yesterday. My feeling is that if a man gets a first-rate improved furnace working right, he ought to be extremely thankful, for he has been exceptionally fortunate. Every additional flue put in for the purpose of saving waste heat is put in at your own risk; and there is nothing more embarrassing than to have one of those things crack at an unfortunate moment, and so render your bench almost inoperative. We are at this time putting in a most elaborate setting in our double retort house, and our benches are doing so well that my impression is there is more going to be done in that way than in any other. There are gentlemen here who have had more experience with thoroughly constructed regenerative settings than I have. We would like to hear what Mr. Nettleton has been doing with his improved setting.

Mr. Nettleton—I hardly want to express an opinion. The furnaces are not working as well as we would like to have them; but yet I cannot doubt that this is partly my own fault. The heats do not seem to be under my control in the way that they have been in all the other furnaces that I have ever tried. I think, however, and of course hope, that with more experience I will be able to manage them as easily as I have the others. There can be no question about the economy in coke. They have been in operation now for something over four weeks. Just before I came here I had the coke that had been sold from our yard tallied up, and, for 20 days, commencing September 28th—I take those dates simply because on the morning of each day there was about 300 bushels of coke in the yard—176 tons of coal were used, and nearly 28 bushels of coke to the ton of coal carbonized had been sold. This is with benches of sixes. If I can in the future say as much for the heat as I can for the economy of the furnace, it will be eminently satisfactory.

The President—Mr. Harbison has been doing a good deal in getting ready to construct a new retort-house. The Association would like to hear from him as to the result of his investigations in the matter of furnaces.

Mr. Harbison—The time has been devoted to getting ready, and we have not as yet put any retorts into the arches. We are building a stack of five benches on the Stedman-Stanley plan. The President alluded awhile ago to some of the older members of the Association. I may say that some of the older members may remember that a certain New York State gentleman some time ago referred to his retort-house or works as being a model. We went to look at his works and tried to copy the model and to improve upon it. We hope a year from this time to have had some experience in working the benches that we are now building. We will then be able to give you, I trust, some satisfactory results. If we have any success you will hear from us then. I have nothing in connection with it that I could state, except the manner of construction, which would not, of course, be of any interest.

Mr. Nettleton—Our Secretary has had some experience in the matter, and we would like to hear from him.

Mr. C. J. R. Humphreys—The very little that we have done at Lawrence has been in the direction of a furnace in front of the bench. A couple of years ago we felt that we ought to put in improved furnaces on account of the value to us of the coke. Every year we had

to bring coke from Boston. We wanted to save coke, but at the same time did not care to go to the expense of putting in a full regenerative furnace, because our stacks were comparatively new, and to tear them all down to put in full regenerative furnaces seemed too expensive. So we had to find some furnace that we could use without tearing down the stacks. It may be that there are one or two furnaces which could be used in that way, but they were not altogether satisfactory to us. So we worked up something of our own. I think I may say that there are only two peculiarities in those furnaces. With regard to the furnace itself, it stands out in front of the bench, thus avoiding the necessity of pulling down the arches; and, instead of being square or rectangular, it is made in an oval form. My idea in thus designing it was that I felt that in an ordinary rectangular furnace the coke did not get down into and fill up the corners, leaving a chance for the air to get in, or causing air-holes, so to speak, and thus burning the carbonic oxide in the furnace itself. That was the reason why I made the furnace on this oval plan. The other peculiarity is about the flues. I can best describe them as being a pipe inside of a box. The pipe is the smoke flue, and the space between the outside of the pipe and the inside of the box would be the air flue. It is just like a fire clay pipe in a fire clay box. My idea (and I make the confession that I got the idea from a water gas apparatus) was that the smoke coming down, as it goes over the side, and then comes down into the flue—the flue being round—would cause the gases to travel more greatly in a whirling motion than would be the case in an ordinary straight flue. Whether it is so or not, I do not know. Those are the only peculiarities of the furnace. As to our working with it I must say it has done better than we expected. We have had no trouble from clinking, and from the first, the furnace has worked very easily indeed. I expect to put in some more next year. I hardly know of any change that I want to make. As we only have two of the furnaces, in our retort house of twelve benches, of course I cannot give you any complete results stretching over any period of time; but I did collect the figures for a week lately, keeping an account of the amount of coal burned in those benches, and of the amount of coke used. The amount of coke used was obtained simply by keeping an account of the number of retorts of coke used, so as to avoid any conflict in items with regard to the measurement of the coke. On the first day our weight of coal per retort charge was only 254 pounds; on the next day, 292 pounds; and on the third, 304 pounds. The percentage of coke used varied, but averaged at about 20 per cent. During the last two days it ran along at 20 per cent. I should say that the retorts, instead of being a full nine feet, only measure about 8 ft. 4 in. on the outside. Of course, 8 inches of very valuable space is lost, otherwise we might possibly do a little better.

Mr. C. Nettleton—Can Mr. Humphreys give us the diameter, and height of the chamber?

Mr. Humphreys—The short diameter is 1 ft. 11 ins., the large diameter being 3 ft. The height is about 5 1-2 or 6 ft. I have here a detailed statement of the workings from October 1st to October 6th:

Results from two of Humphreys' Furnaces—Lawrence Gas Works.

Date.	Coke used, bench No. 7.	Coke used, bench No. 8.	Lbs coal carbonized, benches Nos. 7 & 8.	Wt. coal per retort per charge	Per cent. coke, bench No. 7.	Per cent. coke, bench No. 8.
Oct. 1	8 $\frac{1}{2}$ retorts	8 retorts	18,300	254	24.4	22
" 2	8 $\frac{1}{2}$ " "	8 $\frac{1}{2}$ " "	21,000	292	23.3	23.3
" 3	8 $\frac{1}{2}$ " "	8 " "	21,900	304	23.3	22.6
" 4	8 $\frac{1}{2}$ " "	7 $\frac{1}{2}$ " "	21,900	304	24	21.7
" 5	8 $\frac{1}{2}$ " "	7 $\frac{1}{2}$ " "	21,900	304	23.3	20
" 6	8 $\frac{1}{2}$ " "	7 $\frac{1}{2}$ " "	21,900	304	23.3	20

N.B.—Percentage of coke is in volume. Retorts, 14"x26"x8" 11".

On motion of Mr. Wood a vote of thanks was tendered to Messrs. Weber and Bredel.

Mr. J. L. Hallett, Springfield, Mass., read a paper on

THE USE AND VALUE OF COKE FOR GENERATING STEAM.

Gentlemen: The Springfield Gas Light Company have used their surplus coke for steam heating since 1878. At that time, 1,792 feet of three-inch pipe was laid as an experimental line, connecting the boiler with the company's office, also several stores, offices and dwellings, the space heated aggregating 145,000 cubic feet.

Steam was generated in a 4x16 tubular boiler, with 60 three-inch tubes. There was 12,526 bushels of coke used, being 2,840 bushels in excess of the previous year, when steam was made exclusively to run the exhauster and for general use about the works. The results were satisfactory financially, and especially in providing a medium for the dispensing of a large accumulation of coke. Since 1878 extensions have been made to the steam heating plant and additional boilers erected. Last winter 5,358 gross tons of fuel were consumed, which is equivalent to 294,000 bushels of coke. That is two-thirds more than our surplus coke, and having used bituminous and anthracite coal of different grade and size, both separately and mixed,

it has given opportunity for comparative tests, and we unhesitatingly affirm that coke is the best fuel for producing steam—unless it be crude oil, with which we have not had any experience.

To obtain a given result we found that coke is superior to anthracite (egg size) coal by 10.8 per cent. Compared with buckwheat and pea coal, mixed with bituminous slack, coke will evaporate the same quantity of water with 26.9 per cent less fuel. Our records show conclusively the superiority of coke over coal for making steam. Without advocating the erecting of a steam plant, as that must depend largely on the location of the gas works and cost of reaching the consumer, it may be of interest to know that 250 horse-power could consume the surplus coke of a 5,000 ton gas plant.

Under ordinary conditions a gross ton of coke would evaporate 15,680 pounds of water, which is equal to 10,453 meter units of heat (evaporating 1,500 pounds of water to 1,000 meter units).

Reduced to dollars and cents, on the basis of seventy-seven cents per 1,000 units, a ton of coke would produce \$8.04 worth of steam, less 10 per cent. loss in distribution—net, \$7.24, or 13.1 cents per bushel used under the boilers.

By utilizing the waste heat of the retort benches to heat the feed water, we have a saving of 100 tons of coal for each bench.

A prejudice exists among some against the use of coke on account of a *supposed* damaging effect on the grate bars and tubes of the boiler. That is not true, in our experience. We have used coke exclusively under one boiler since 1870. Continuous use, day and night for eight months in the year, and careful inspection find it in as good condition as other boilers fired with coal. The grate bars have not been renewed and are apparently in as good condition as when they were set.

Bearing on the subject of the value of coke for making steam, I submit the following answers from persons that have given the subject their attention:

No. 1.—“A factory tried coke under one of their boilers, and found that it took an equal weight of coke or coal to do the work; but as coal cost \$6.25 per gross ton, and coke, at 8 cents per bushel, but \$4.96, they saved 20 per cent. and continued the use of coke.”

No. 2.—“When it has been used it has been invariably estimated as the cheapest fuel. It has been difficult to supply the demand for such use.”

No. 3.—“A company used six tons of hard coal under their boilers in one week. The next week they used coke against the protest of the fireman, and burnt just seven tons.”

No. 4.—“Likes it better than anything he ever used; prefers it to any other fuel, as it makes steam faster, and is cheaper than any kind of coal.”

No. 5.—“Number 5 says that coke at 10 cents per bushel is cheaper to him than coal at \$7.00 per ton.”

No. 6.—“A prejudice formerly existed in this place against coke for firing boilers. It was claimed that coke injured the boiler and setting; but such prejudice, born of indolence, has long since passed away. Can sell all the coke made to users of steam.”

No. 7.—“Our experience has been that the use of coke does not damage the iron of the boiler.”

No. 8.—“Have used coke 25 years under a boiler at gas works. It has been in constant action, and apparently is in good condition.”

No. 9.—“Nothing used but coke, eight to nine years, and boiler now in perfect condition.”

No. 10.—“Over 15 years continuously, night and day.”

No. 11.—“Used coke under boiler for 10 years, the boiler being in use 24 hours each day.”

Discussion.

Mr. Bredel—Did the gentleman find any difference between the use of hard and soft coke—that is to say, coke produced by high and low heats?

Mr. Hallett—No difference at all. We have been supplying steam now since 1878, and one 45-horse power boiler consumed 50 tons the first year. Our business has grown to 1,000-horse power, with the consumption last year of 5,200 tons. We have used all kinds of fuel, and in all ways. Considering that the Lehigh egg coal was the best we could obtain, we tried 100 tons of the same, compared it with coke, and found the result to be in favor of the latter, on what we supposed was the best coal that we could possibly use. We also used soft coal and the small sizes of Lehigh coal, but every test made showed that we could make more steam with coke than with coal. We run our retorts at high heats, and our yield of gas per lb. of coal carbonized will average, throughout the year, 5 ft.

The Secretary—The following tables, handed to me by Mr. A. E. Boardman, contain a report of the results at the pumping station of the Macon, Georgia, water works:

TABLE NO. I., showing comparison of coal (bituminous) and coke as fuel consumed in the Waterville pumping station of the Macon (Ga.) Water Works. Average steam pressure, 70 lbs.; average water pressure, 100 lbs. Pump, a Worthington Compound Duplex, 12 in. by 20 in., by 10 in. by 15 in.

Date, 1885.	Water pumped, gallons.	Fuel used, lbs.		Waste, per cent.	Duration of test.	Gallons pumped per lb. fuel
		Coal.	Coke.			
April	14,728,000	68,974	7.79	30 days	Av'ge 270.62 Av'ge duty 41,699,000
May	17,102,000	74,448	6.35	31 "	
June	19,084,000	71,628	7.62	30 "	
July	21,716,000	75,012	7.52	31 "	
Aug.	21,875,000	75,858	7.43	31 "	
Sept.	21,049,000	78,481	7.34	30 "	
Oct.	21,715,000	72,870	7.65	31 "	
Nov.	20,282,000	93,060	Av'ge 12.7	30 "	
Dec. 1886	17,273,000	67,330		31 "	
Jan.	19,192,000	87,580		31 "	
Feb.	16,780,000	67,640	28 "	Av'ge duty 37,036,000	
March	15,719,000	63,050	31 "		

Taking the value of coal to be 100, the above shows coke to be 87.

TABLE NO. II., showing further tests with the same pump. Steam pressure, 60 lbs.; water pressure, 68 lbs.; duty, 32,148,000 gals.

Date, 1886.	Water pumped, gallons.	Fuel used, lbs.		Duration of test.	Gallons pumped per lb. coal.	Gallons pumped per lb. coke.	Waste, per cent.
		Coal.	Coke.				
May	3,032,080	15,625	94 1/2 hrs.	191.45
"	4,207,280	Mixed,	18,421	133 "	228.40
"	12,911,940	41,800	415 "	309.73	8.91
July	5,605,740	19,200	9 days	291.92
"	12,842,700	51,640	18 "	248.70	12.56
"	3,359,900	Mixed,	12,400	4 "	270.72
Aug.	7,922,820	36,780	11 "	215.41
"	10,167,040	39,200	12 "	259.62
"	6,245,760	30,580	7 "	204.24
1887							
Jan.	18,055,620	61,200	19 "	295.02
"	9,729,900	41,120	12 "	236.62

By these tests we find the value of coke to be 77, taking coal as 100; and a mixture of about equal quantities to be 82 1-2. A fair estimate would be, coal, 100; coke, 80.

Mr. C. Nettleton—What sort of coal is that from which Mr. Boardman obtained his coke? Of course some coals contain more ash than others, and that might make a difference. The South Alabama coal might give different results from Pittsburg coal.

The Secretary—The document does not show that. It simply shows that the coal against which the coke is compared was bituminous coal.

Mr. Helme—I know that Mr. Boardman gets his coal from Tennessee, near Chattanooga.

On motion of Mr. Sherman a vote of thanks was tendered to Mr. Hallett for his paper.

APPOINTING THE COMMITTEE OF INVESTIGATION.

The President—Is Mr. Taber ready to report the names of the proposed Committee of Investigation?

Mr. Taber—At the request of the members of the Committee, appointed for that purpose, I report the following names: Frederick S. Benson, Brooklyn, N. Y.; Charles F. Prichard, Lynn, Mass.; T. Littlehales, Hamilton, Ontario; James Somerville, Indianapolis, Ind.; A. E. Boardman, Macon, Ga.; Wm. J. Fay, Denver, Col.; and J. B. Crockett, San Francisco, Cal.

The President—The Chair awaits a motion.

Mr. Harbison—I move that the report of the Committee be accepted, and that these gentlemen be declared the Investigating Committee, in the expectation that every man will perform his duty. [Adopted.]

SUPPLEMENTARY REPORTS FROM EXECUTIVE COMMITTEE.

The President—Mr. McMillin wishes to present reports on two additional matters referred to the Executive Committee. The members of the Association may remember that last spring a donation of 5 pounds sterling was sent by a Scottish gentleman to the proprietors of the AMERICAN GAS LIGHT JOURNAL, to be devoted in such way as they thought best for the interest of the fraternity on our side of the Atlantic. The JOURNAL folks turned the money over to this Association, and the Association turned it over to its Executive Committee, who are now ready to report, through Mr. McMillin, a recommendation in regard to the disposition of the sum named.

Mr. McMillin—I think we have had no question harder to wrestle with than this. We finally determined on our report only within the last few minutes, which is as follows:

"The undersigned were appointed by the Executive Committee to take into consideration a communication received by the AMERICAN GAS LIGHT JOURNAL from a resident of Scotland, who desires that his identity be concealed under the title of 'An Old Scottish

Subscriber.' In this communication the donor desired to convey to the American gas fraternity a slight token of his esteem in the shape of a draft for five pounds sterling, to be used or disposed of in such manner with any of the gas associations in this country as the editor of the JOURNAL might suggest. The JOURNAL people have kindly suggested that the Association offer this money (about \$25) to the best paper on some subject to be selected. Your Committee suggest that the Association offer this as a premium for the best paper on the subject of 'Naphthaline,' the paper to be read at the next meeting of this Association.

"They further suggest that the Secretary convey to the donor the thanks of the Association for his generous offering.

E. McMILLIN,
W. H. WHITE,
J. P. HARBISON, } Committee."

On motion of Mr. Sherman, the report of the Committee was accepted, and the disposition of the money recommended by the Committee approved.

The President—Does the Executive Committee couple with that any suggestion as to who shall be the judges?

Mr. McMillin—No; they leave them to be appointed at the next meeting.

PUBLISHING THE PROCEEDINGS.

Mr. McMillin—The same Committee had another question before it—that of the publication of our proceedings—a subject which has become something of a chestnut. The Executive Committee feel that the question must be met at this meeting, in deference to the parties who are interested in the matter. We have made our decision and I will announce it, but I will have to reduce the report to writing after I have made it orally:

It is the sense of the Committee that, in the future, the Association should employ its own stenographer, make its own report, and furnish copies of that report to all of the gas journals willing to pay their pro rata share of the expense. In short, that is the substance of their recommendation.

Mr. Clark—I move that the report of the Committee be accepted and adopted.

The President—You have heard the report of the Committee, recommending that for future meetings of this Association the stenographer be employed by the Association instead of by the AMERICAN GAS LIGHT JOURNAL, and that the report of the proceedings of the Association be then furnished by him to all the journals that are willing to pay their proportionate part of the expense of his employment.

The motion of Mr. Clark was agreed to.

THE TORONTO MEETING.

Mr. Pearson—As I was not here when it was decided to accept the invitation (tendered by the Toronto Gas Light Company), to the Association, to hold its next meeting in that city, I wish to take this opportunity of expressing my gratification with your action, and my appreciation of the honor you do us by meeting there. I hope that at the conclusion of the next meeting of the Association no member will have reason to regret the acceptance of the invitation.

PRINTING THE PAPERS IN ADVANCE.

Mr. A. C. Humphreys—I move that at the future meetings of this Association the five papers to be read, as designated in advance by the Executive Committee, be printed by the Secretary in time for distribution among the members at the opening of the session; and that the Executive Committee take the proper action to insure the completion of those papers long enough in advance of the meeting to permit them to be printed. In making that motion I would say I do not believe this will make it any harder for any member to prepare his paper. Although I put off preparing my paper until last Friday, I could have written it just as well a month ago—perhaps a little better—if I had been compelled to do it at that time. [Adopted.]

THE GAS INTEREST IN ENGLAND.

Mr. Nettleton—If there is no other business now before the Association, I, for one, would be very glad to hear from Mr. Spice as to how gas matters are in England.

Mr. Spice—Mr. President and gentlemen: If I had received notice that such a question would be asked me, I would have prepared myself to answer it in a proper manner; but in default of such intimation you will have to take whatever may happen to come into my mind. I may say that the English gas industry is in a prosperous condition, notwithstanding all the efforts of the electricians of the world, who find their way to London as well as to the United States. It is an axiom that it is safer not to prophesy until you know what is before you; but about eight years ago, when a bombastic message from America arrived in England to the effect that the gas industry was doomed, that the gas works of the world were to be covered with a pall such as that which descended many centuries ago upon the old city of Pompeii, that we were to be covered up and never more seen, that the place that knew them then should know them no more, I ventured, at that desperate epoch in our business, when the holders of gas stocks were frightened almost out of their senses, to prophesy that the advocates of electric lighting would prove to be blessings in disguise. And so it has turned out. The

rate of progress, of development—or call it what you will—the rate of the growth of the consumption of gas in England has been about nine per cent. per annum. I understand that greater things are done in America, in the way of progress, than in England. In America, a city beginning with but a thousand people, will, before you really know where they are, become a city of 50,000 inhabitants. If you make allowance for that very rapid growth of population (of which we know comparatively nothing in England), you will see that gas matters in England and in America have gone hand in hand, from prosperity to prosperity.

Why has electric lighting proved to be (as I ventured to prophesy many years ago it would be) a blessing in disguise? Why, sir, it is because we are all of us the better for being stirred up to greater exertions by some kind of stimulus which acts, perhaps, upon our brains through our pockets. We are thereby stimulated to greater exertions, to making greater efforts in the direction which we think will tend toward our prosperity. That is a general truth not admitting denial. It did act in that way in respect to the gas industry of England, and it has acted in that way upon the gas industries of this great and glorious country. Men who were once accustomed to a glimmering light, and who could, by getting near enough to it, manage to read the newspaper, or conduct ordinary business, when once made familiar with the light of a great industry were so influenced by it that the greater light eclipsed the lesser, as great lights always will. It led to the necessity for five, six, seven, and eight feet per hour in the burners of the public lamps, instead of the miserable three feet rush-light concern which, through the penuriousness of the parish vestries, the people of London once had to be content with. Formerly the gas lights in the streets of our towns in England were just sufficient to make darkness visible; and I have often said that if a thief in a London street wanted to hide away from the police, the most secure place to which he could go was to step into the shadow of a lamp. That may sound somewhat strange to you, but it is a fact that he would have been sufficiently obscured by the shadow cast by the gas light. Where three feet of gas formerly sufficed, it is now the fact that five times three feet are used. There was an increase of consumption at once upon the introduction of electric light; but with the increase of consumption, and the resultant diminution in price which almost necessarily followed, there was much complaint that the great increase of consumption was accompanied also by an increased degree of impurity—such as gas consumers had not been accustomed to; and this want of purity was bitterly reflected upon by that able American scientist, Mr. Edison, who described the "stinks" as coming up into the room from holes in the floor, or chinks in the wall, or as descending from the burning gas chandelier from the ceiling. But that description (if it ever were true) has now ceased to be the fact. In England we are now tied down to a degree of purity such as was not known until the electric light came. In one way or another, by cheapening the production, by increasing the purity, by applying that stimulus to every department of gas production, and delivery, and by disseminating information of all kinds for the benefit of that great public who are our customers, we have thriven, and are going on to thrive, and have had no check to that development of growth by which we are becoming greater and greater. One thing has tended to maintain the position of the gas companies, and that has been the application of gas as a motive power for the production of electricity. We have had, in the last year, in London, a notable example of that, where a very large hotel, built after the model of your large American hotels, really pay more for gas (after the whole house had been lit with electricity) than they ever did before. There is no economy in electric lighting, so far as they are concerned; but they want it. I have said that electric light is, and always must be, a luxury. It is not the poor man's light; it is the light for those who can afford to pay for it. And that is one of the assurances which we as gas men have that we shall always be able to hold our own. I thank you, gentlemen, for your kindness and attention.

BACK AGAIN TO THE PUBLICATION OF PROCEEDINGS.

Mr. McMillin—Having to make two reports awhile ago it seems that I did not do all that was expected of me. My attention has been called to the fact that I did not make one as full as was intended. I still think that I did; but will state what the Committee wish me to, and then leave the matter for the Association to settle. The Committee instruct me to report the recommendation that the resolution (passed some years ago) making the AMERICAN GAS LIGHT JOURNAL the official organ of this Association be rescinded, and that the proceedings be hereafter reported and furnished as I suggested. The Association will employ the stenographer, and furnish copies of the reports to such gas journals as will pay their pro rata share of the expense. Before we could properly act upon the resolution already adopted, the Committee thought it was necessary that the resolution formerly passed, making the AMERICAN GAS LIGHT JOURNAL the organ of the Association, should be rescinded.

The President—As that is a somewhat different motion from the one already put, I will have to put the question to the Association again.

Mr. Nettleton—I sincerely hope the amendment now offered by Mr. McMillin will not pass, and I say so from motives of personal kindness toward Mr. Thomas, who is now so sick that he is confined to his bed. Personally, although I was sorry to see it adopted, I was content to have the previous resolution decided without protesting against it. I would, however, be very sorry to have this action added to that.

Mr. Wood—I quite agree with the remarks made by Mr. Nettle-

ton. I believe it would be a very unjust and ungenerous act on the part of this Association to pass a resolution of the kind proposed. If not directly, it is certainly indirectly reflecting upon the conduct of Mr. Thomas, an old and honored member of our Association. I sincerely hope the recommendation of the Executive Committee will not be approved.

Mr. Graeff—As one who is, perhaps, as much interested in this matter as any one else, I wish to say I trust the matter will be allowed to remain as it is. If Mr. Thomas were present I might not take this position; and I confess the fact of his absence did not occur to me when I asked Mr. McMillin whether the Committee's report, as made, covered all the matter of their recommendation. I, therefore, if it is proper to do so, ask the Committee to reconsider its report, and to limit it to the recommendation already made and acted upon.

Mr. A. C. Humphreys—I ask if the passage of the first resolution is not, in effect, the same as if we passed the resolution now suggested.

The President—Not exactly.

Mr. Brown—I wish to say I heartily agree with what Mr. Graeff has stated.

The President—We have now heard from the editors of the other papers having an interest in this matter. I hope the resolution which constituted the AMERICAN GAS LIGHT JOURNAL the official organ of this Association will not be rescinded. Under the circumstances, will the Committee withdraw the resolution or shall we vote it down?

Mr. McMillin—As chairman of the Committee, of course, I have no authority to withdraw the resolution which they instructed me to report. I thought the first resolution virtually covered it; but some of the gentlemen of the Committee insist that it did not. I cannot withdraw the resolution, for I have not the authority to do so—whatever my personal feeling may be upon the subject.

Mr. A. C. Humphreys—I would like to ask how the AMERICAN GAS LIGHT JOURNAL can remain the organ of this Association if the original motion is passed.

The President—The question has been raised as to whether this covers the question of the notices which are sent by the Secretary of the Association to the JOURNAL, and which are published in it. I would ask the chairman of the Committee whether, in his judgment, the notices are hereafter to be sent to the other journals, or are only to be sent to the paper which has heretofore published them.

Mr. McMillin—I have only made the report as I was instructed to make it by the Committee. If you want to know any further as to what that report means, I shall have to ask you to take the understanding of the Committee with regard to it.

Mr. Clark—But the Committee were discharged, by vote of the Association, after having made their first report.

Mr. A. C. Wood—As I understand the matter, the AMERICAN GAS LIGHT JOURNAL, as the official organ of the Association, has heretofore had its stenographer here to report the proceedings of the Association, and has done so without any expense to the Association?

The President—Yes.

Mr. Wood—And the recommendation of the Committee is that hereafter the Association employ its own stenographer, and publish the proceedings in such papers as may desire to print them.

The President—Copies of the report are to be furnished by the stenographer to such papers as are willing to bear their proportion of the expense.

Mr. Wood—The effect of that would be to take the entire matter out of the hands of Mr. Thomas, our old friend and honored associate. I appeal to the leniency of the Association, and to the forbearance of the Committee. I move that the motion to accept the recommendation of the Executive Committee be rescinded.

Mr. Helme—I second that. I do not think that an old member of this Association, one who has been with it from the beginning, can fail to recollect how the AMERICAN GAS LIGHT JOURNAL has always stood by us, and rendered all the aid possible in the promotion of the interests of the Society, and in the protection of the gas business generally. I have, on one or two occasions, made a movement toward having the JOURNAL paid for the great expense they were at in publishing the proceedings, but the publishers of the JOURNAL have refused payment every time. Now, if that conduct on their part—if that treatment of our Association, is not worthy some consideration at our hands, especially from the older members, then I must say that good treatment goes for nothing. I for one, as a member, shall be very sorry indeed to see the thing changed from the course which has been followed for some time past—from a time, in fact, when it was very doubtful whether this Association could be made a success. I can recollect very well, when, in this city, Mr. Steel, of Buffalo, moved that this Society take steps toward its dissolution. But that resolution did not pass—thank heaven!—and we are here to-day under prosperous circumstances. I do not know from what source we got more or better aid in attaining our present prosperous condition than we got from the AMERICAN GAS LIGHT JOURNAL, and I do think something is due to them in consideration for the great help they then gave us. They at least deserve good treatment at our hands. Let us not cast them aside as we would an old horse for which we have no further use.

Mr. Floyd—As one of the old members of this Association I can second everything that Mr. Helme said. I think we ought now to stand by the AMERICAN GAS LIGHT JOURNAL, for it stood by us in our adversity. It deserves our assistance now.

The President—A motion is made by Mr. Wood that we reconsider

the vote by which we resolved hereafter to employ our own stenographer.

Mr. Wood—My motion was to rescind the previous action.

The President—It amounts to the same thing. The motion to reconsider is the proper parliamentary rule.

Mr. McMillin—I do not know whether the other two members of the Committee are in the hall or not to speak upon this motion—

Mr. White—I am right here with you, McMillin.

Mr. McMillin—There has been a good deal of dissatisfaction expressed that the Association should father one journal to the exclusion of all others; and the Committee has endeavored to consider this question from all its various standpoints. I do not believe that any of the gentlemen who have spoken upon the other side of the question, and against this report, entertain any higher opinion, personally, of Mr. Thomas, or of the managers of that paper, than do the members of this Committee. (Applause.) They have received favors from him; they are all under obligations to him; they are all his personal friends. But, I think it would be in just as good taste for an old gas engineer of twenty or thirty years' experience, to come into this Association and ask us to protect him against the rising young fellows who are coming up every day, as it is for the AMERICAN GAS LIGHT JOURNAL to be always asking the support of this Association, as against its competitors. Certainly, there is no feeling on the part of the Association against the JOURNAL—it has been the friend of us all, at all times; but other papers are now struggling for existence, and they are doing their duty and are doing it well. I see no reason why we should deny them what we give to the secular press. Other associations permit the publishers of the daily papers to attend their meetings, take notes of the proceedings and publish them. If they send a shorthand reporter he can take down the papers which are read, and they can be published also. That course has not been followed in this Association. We have given to one journal the exclusive privilege. I am opposed to rescinding what we have already done in this matter. We certainly have not done anything more than is fair, and I think Mr. Thomas would admit that if he were here with us.

Mr. Harbison—As a member of the Committee that made this report to the Association, I wish to say I am not willing to stand second to any member of this Association in the expression of high esteem in which I hold Mr. Thomas, and the gentlemen who are connected with him in the management of the AMERICAN GAS LIGHT JOURNAL. I have never received from them anything but the most courteous attention. I have always entertained for them, and still do, the kindest of feelings, and the most hearty wishes for their prosperity and success. My desire as a member of the Committee (and I know that the same feeling existed with each of the other gentlemen) was simply to perform our duty with reference to the welfare of the Association. We could not permit our personal preferences to influence our action. We could not allow our kind feeling toward the gentlemen connected with the JOURNAL to influence our report. We could not, as a Committee of this Association, make a report which simply expressed our personal wishes with regard to the matter; otherwise our report might have been very different from what it was. As Mr. McMillin has said, there has been for years the growing feeling that the proceedings of this Association should be published in more than one journal. It was only the deference due to that largely expressed wish on behalf of many members of the Association which induced me to give my vote for the action which has been recommended by the Committee. As I have said, I could not in justice to the members of this Association, who have honored me with a position on the Executive Committee, do otherwise than I have done, by agreeing to the report which has been presented by Mr. McMillin on behalf of the Committee. The reason leading to the recommendation by the Committee that the resolution, passed years ago, making the AMERICAN GAS LIGHT JOURNAL the organ of the Association, be rescinded, was because we did not see, with that vote standing on the records of the Association, how any different action from that provided for by that resolution could be taken by the Association. As long as that vote stood no other action could consistently be taken. The first thing to be done, therefore, was to repeal that vote. If Mr. McMillin had not added that recommendation to his report, the balance of the report would be of no effect. You cannot, in my opinion, pass a vote giving to this Association the right to employ its own stenographer, and call on the various papers that choose to publish this report for their proportion of the cost of furnishing it, so long as that vote stands on record which makes the AMERICAN GAS LIGHT JOURNAL the official organ. It is stultifying yourself to attempt to do it. I want the Association to understand that fact. We must, in my opinion, reconsider that vote before any other action can be taken which will be of any effect or avail.

Mr. Sherman—Is there any objection to permitting other papers to send their own reporters here to take a record of our proceedings?

The President—Yes. The objection is made by the AMERICAN GAS LIGHT JOURNAL that they, being the official organ of the Association, alone have a right to publish a stenographic report.

Mr. Sherman—Have the other papers no right to send a reporter here?

The President—They have no right to send a reporter to take a stenographic report. Reporters may come in here and take brief notes, but they cannot furnish stenographic reports to other journals. Nor can the papers which are read here be printed in any other journal until after they have been printed in the AMERICAN GAS LIGHT JOURNAL. The members of the Association know that some-

times, in the stress of business, it has been a long while before the papers have appeared in the AMERICAN GAS LIGHT JOURNAL.

Mr. Sherman—I supposed any paper had a right to send a reporter in here to make a report of our proceedings.

The President—No; that has not been permitted.

Mr. Wood—But has there been any vote or resolution against permitting other journals to do that?

The President—The Executive Committee have always understood that it would not be allowed. In fact, my attention has been called, during this meeting of the Association, by the Manager of the AMERICAN GAS LIGHT JOURNAL to the fact that other reporters were here, and I have stopped them from taking notes. That is just what is the matter.

Mr. A. C. Humphreys—Then it is evident that Mr. Wood, and some of the other gentlemen, have made their remarks under a misapprehension.

Mr. Wood—I think I fully understand the situation; and, with due respect to the report of this special Committee, I still insist upon my motion. I must say I think the thing is altogether wrong, and must have been misconstrued by them. The resolution heretofore passed by the Association makes the AMERICAN GAS LIGHT JOURNAL our official organ. I do not understand that any action of this Association has ever restricted any other newspaper from sending a reporter here to take down the proceedings of the Association. If there is any such resolution I would like to have the Secretary call attention to it. If this special Committee now propose to divide the reports of our proceedings with the AMERICAN GAS LIGHT JOURNAL, and with the other two now existing journals, as suggested by Mr. Harbison, what shall be done with the next, and with the next, and so on with all the other journals devoted to our industry which may come up hereafter?

Mr. McMillin—Whatever journal is willing to pay for the report will get it.

Mr. Wood—So long as we have an official organ of the Association I do not see the necessity of giving that preference to any more journals. But I would grant the privilege to other journals of reporting and publishing the proceedings, if they desire to do so.

The President—How about the papers which are read?

Mr. Wood—Let them report those also, if they wish to.

The President—Would you let them have copies of the papers?

Mr. Wood—If they send a stenographer here he may take down the papers as they are read; or, if the writer of the paper desires, he may furnish copies of his paper to the other publishers.

Mr. McMillin—That is just what this Committee proposes to do.

Mr. Wood—It seems to me you proposed to make all the journals "official organs." That is the effect of it.

Mr. McMillin—No; the Committee propose to put them all on the same footing, so far as the publication of the reports is concerned. While the resolution stands as it is, it is not the proper thing for parties reading papers to give copies to other journals than the AMERICAN GAS LIGHT JOURNAL, our official organ. At least, I have always been governed by that understanding.

Mr. Wood—It seems to me that, as we long ago proclaimed the AMERICAN GAS LIGHT JOURNAL to be our official organ, it should continue so—at least for the present.

Mr. Sherman—What does the Committee propose to do with the papers which are read? Will copies be sent around to the different offices?

The President—I understand Mr. McMillin proposes that, in the future, the publisher of any journal who wishes to do so, shall have a chance to publish any of our papers as early as the AMERICAN GAS LIGHT JOURNAL does; and that they shall also have a chance to report stenographically the debates, or to have a copy of the report made by the Association's stenographer, upon paying their proportion of the expense. All the gas light journals of the country, if they like, can hereafter report the proceedings of our Association.

Mr. Sherman—But they cannot all have the papers at the same time.

The President—Certainly they can, if they are printed beforehand.

Mr. McMillin—That will be their business. If they can get the copies, they can publish them.

Mr. Wood—I think this Association, representing the vast amount of capital engaged in the gas business, should have an official organ. I still insist upon my motion to rescind the previous action of the Association in adopting the report of this special Committee.

Mr. Lowe—As I understand it the AMERICAN GAS LIGHT JOURNAL is still our official organ; and I do not think we want more than one. I do not think the last resolution contemplates that we shall have more than one. If Mr. Wood is willing to permit each journal to send a stenographer to take minutes of the proceedings of this Association, and publish them, then I do not see why we would be any better off by rescinding the motion already passed. It would involve merely the question of letting them contribute to the expense of furnishing the report, and I am quite sure that each one of the existing journals would be happy to pay one-third of the expense, and would prefer to do so, rather than pay the entire cost of procuring a report. So far as the papers read are concerned, they can have those at any rate, inasmuch as they are to be printed.

Mr. Graeff—My opinion of this official organ business is that a report of the proceedings can be furnished by the Association to any paper that wishes it, without at all disturbing the relation which the present JOURNAL sustains to the Association as its official organ. My idea in asking the question I did was to ascertain whether the motion carried with it the publication of the official notices of the

President and Secretary. I understood the President to rule that it did not. I consider that so long as the AMERICAN GAS LIGHT JOURNAL is the sole recipient of the official notices which come from the President and Secretary, it continues to be the official organ. I consider that the placing of the report of the proceedings of this Convention within the reach of other journals does not disturb the official organ at all. I understand that to be the President's ruling.

The President—That is my opinion.

Mr. Graeff—I do not understand that any member of this Association is better posted on Parliamentary law than is our worthy President; and I am quite content to accept his understanding of the effect of the motion which we have adopted. Speaking as the editor of one of the journals, I wish to say I do not care to disturb the position of the official organ. I would not have the official organship transferred from the old journal to my own, for I have no desire for it. But, speaking now as a member of the Association, I believe that we ought to publish our proceedings as widely as possible, so that they may be read by members of all the industries that we represent. I have in mind the case of the Western Architect's Association, which had been confining its reports to one journal. Finally they got tired of that, because, while the journal had a good representative circulation, there were other journals coming up which went into quarters where that journal did not necessarily go, and so they departed from the old custom. Now, instead of having one report published, they permit nine journals to have a report, and any architect who does not get a copy of the proceedings of the convention must be a very sorry sort of chap—if he does not take one paper of the nine. As a member of the Association, I believe we should place the proceedings of this convention and of all our conventions, within the hands of every gas man who reads. On that ground I ask for the support of this report made by the special Committee, if you rule that such further support be necessary.

The President—The motion now before the house is that the action just taken by the Association, in accepting the report of the sub-Committee of the Executive Committee, be reconsidered.

Mr. Wood—That it be rescinded.

The President—The proper motion now is to reconsider. At a later time, when the period within which it can properly be reconsidered has gone by, the proper motion would be to rescind. The proper motion now is to reconsider; and the President so rules. Are you ready for the question?

Mr. Lowe—Let us have a standing vote on that question.

The President—Those in favor of reconsidering the acceptance of the report of the Executive Committee will say "Aye;" those opposed to reconsidering it will say, "No." The Chair rules that it is not a vote. Therefore, the report of the Committee stands accepted.

Mr. Nettleton—I wish that the Chair would state just what that report is, so that there may be no misunderstanding.

Mr. McMillin—The report, as voted upon, was that the proceedings be furnished to those journals paying their proportionate share of the cost of making the report.

The President—But it does not affect the official standing of the AMERICAN GAS LIGHT JOURNAL, as being the organ of this Association. (Applause.)

Mr. Helme—Will the papers which are read be handed as usual to the AMERICAN GAS LIGHT JOURNAL?

The President—I would say they would be entitled to the first copy; and if anybody else wants a copy he can get it.

Mr. Helme—It seems to me that by this resolution that matter is left open. You had better decide that question here and now.

The President—I think that that will arrange itself, because we are to have the papers printed hereafter before they are read.

Mr. Harbison—Do I understand that the report of the Committee, which we have acted upon and accepted, is to the effect that hereafter the Association shall employ its own stenographer?

The President—Yes.

Mr. Harbison—And that the papers paying their pro rata of the cost shall have a copy of the proceedings, and of the papers read?

The President—Yes.

Mr. Harbison—We did not provide that any one journal should have all the papers handed over to it?

The President—I understood Mr. Helme's question to be, not with regard to the report of the stenographer, but with regard to the papers which were read. The stenographer, as I understand it, will furnish a copy of his report to each of the journals, but the papers read will not be reported.

Mr. Harbison—It is well to understand that right here. Are not the papers read considered as being part of the stenographer's report?

The President—They have not been reported by the stenographer heretofore.

Mr. Harbison—But they might be, hereafter, if the Association employs a stenographer. It is simply a question whether he shall make a stenographic report of the papers, or whether the original paper shall be furnished to him.

The President—The chair is open to instruction on this matter. I suppose if a journal wants a copy of a paper it will be able to get it.

Mr. Harbison—I would like to know, for my own guidance, what the proper action will be.

Mr. Gilbert—As I understand it, the papers which are hereafter to be read are to be printed, and ready for distribution at the meeting of the Association.

The President—Some will be printed; all may not be.

Mr. Gilbert—Those which are accepted, to the number of five, are

to be printed? As to those papers, of course, the journals wishing to publish them will have copies furnished to them simultaneously?

The President—Certainly.

Mr. Gilbert—This year, as I understand it, the papers must follow the ordinary course, and go to the paper which we recognize as our official organ.

The President—But, if the other journals wish to take copies of those papers after they are printed, they are now at liberty to do so.

Mr. Gilbert—But they may not care to do that after they have been published by the AMERICAN GAS LIGHT JOURNAL.

The President—If I have not correctly stated the views of the Association, or if there is any doubt as to just what is intended by the action we have taken, it would be well to have it stated more explicitly.

Mr. A. C. Humphreys—Then, I move that it is the sense of this Association that the stenographic report referred to by the special Committee is understood to be the report of the entire proceedings of the meeting.

The President—Mr. Humphreys offers a resolution explanatory of the vote previously passed, to the effect that the words "stenographic report," which has already been ordered to be given to all the journals willing to pay their share of the expense, shall be understood to mean a report of all proceedings of the Convention, including the papers which are read. So that any journal may publish all the proceedings, including the papers. There is to be no preference given to any journal as to any of the papers.

Mr. McMillin—Our report is to the effect that we furnish a copy of the proceedings, inclusive of the papers, to all journals willing to pay their part of the cost of making the stenographic report. That was the idea of the Committee.

Mr. Helme—It may take some time to make two or three copies of the papers. In the meantime, is each of the journals to remain out of possession of the papers until these copies have been made and handed to the other journals? Let us see how that thing will work.

The President—You will have to ask the Executive Committee as to that.

Mr. Helme—What I want to know relates to the five papers which are to be printed. I understand that copies are to be furnished to the journals, when they are distributed to the members. How will it be as to the others?

The President—At the next meeting of the Association the papers (five in number) designated by the Executive Committee will be printed before the meeting of the Association, and hundreds of copies distributed. A copy will be given to each journal that wants it.

Mr. Helme—That is all well enough as to those five papers. How will it be as to the others?

The President—The resolution adopted to-day provides only for the printing of the five regular papers. If more than five papers are presented, I would ask Mr. Harbison what he wants to have done with them. My ruling did not apply to those. I do not understand what disposition the Executive Committee wish to make of those other papers.

Mr. Helme—Suppose two or more papers are read after the five regular ones are disposed of. Will the AMERICAN GAS LIGHT JOURNAL have those; or must duplicate copies be made for every other journal?

The President—I will leave that for Mr. McMillin to answer.

Mr. McMillin—The stenographer can make type written copies of those, and they will then form a part of his report.

[The motion of Mr. A. C. Humphreys that "It is the sense of this Association that the stenographer's report, referred to by the Special Committee, is understood to be the report of the entire proceedings of the meeting," was then agreed to.]

VOTES OF THANKS.

The President—Is there any other business to come before this meeting of the Association?

Mr. Lowe—Before bringing this very interesting and valuable meeting to a close, I think we ought, in justice to our worthy President—our earnest and whole-souled friend, Malcolm S. Greenough—tender him a hearty vote of thanks for his very able and interesting address—the best that we have had, according to my notion, at any meeting of the Association. I think we also owe him a cordial vote of thanks for the very masterly and forbearing manner with which he has conducted the proceedings of this Association. I, therefore, move that such action be taken, and that we spread it in full upon the records of our Association. [The motion was put by the Secretary, and unanimously adopted.]

The President—Gentlemen, I am obliged to you all. At times, I feared that I hurried up your proceedings with rather more alacrity than civility; but if I have given satisfaction as your presiding officer it is a matter of great gratification to me to have done so.

Mr. Harbison—As a member of the Executive Committee it has fallen under my notice, during the past as well as in former years (particularly so during the past year) that the Secretary of this Association has a large amount of work to perform. There are very few of the members of this Association who fully appreciate that fact, owing to their lack of knowledge of the extent of it. They may come in contact with him a number of times, in a very pleasant manner, during the year; but it has come to my knowledge that he performs a very large amount of work in the interest of this Association, of which the members generally have no knowledge. I am thoroughly aware of the very able, earnest and painstaking way in

which the duties of his office have been performed. His report to this Association of the management of our finances would do credit to an able New York banker. He has taken care of them in a remarkably able and successful manner. He has performed all his duties equally well. He is ever obliging, ever good-natured, and never gets out of patience. I move a vote of thanks to Secretary Humphreys for the exceedingly able and efficient manner in which he has performed the duties of Secretary during the past year.

The President—I think the entire Association is ready to second the motion made by Mr. Harbison, and it gives me very great pleasure to put it before you. Those in favor will say "Aye." I will not put the negative of the question, simply because it has no negative side. [Adopted.]

The Secretary—I am exceedingly obliged to all the members of the Association for this very kind expression of their approval; and I am particularly obliged to my friend Mr. Harbison for his kind remarks in moving the question.

INVITED TO ATTEND THE AMERICAN INSTITUTE FAIR.

The President—We have a letter from the American Institute of New York, giving the members of the Association a very cordial invitation to attend the Fair now being held. Complimentary tickets are inclosed, which the Secretary will distribute to those who desire them.

On motion of Mr. Boardman, the invitation and tickets were accepted with thanks.

VOTE OF SYMPATHY.

Mr. Vanderpool—Mr. Thomas, one of our friends, and an honored member, has been sick in bed for some weeks. I think it would be an appropriate token of our respect for him if this Association were to pass a resolution of sympathy with him in his illness. I make that motion. [Seconded by several.]

The President—It is moved that the sympathy of this Association be tendered to Mr. Jos. R. Thomas in his affliction, and that the Secretary be requested to communicate to him that fact. [Adopted.]

Mr. Harbison—Let me suggest that a hearty vote of thanks is due to the Committee of Arrangements who superintended our entertainment at this meeting. Therefore, I move the thanks of the Association to the members of that Committee for the able and efficient manner in which they provided for our welfare. [Adopted.]

The Association then adjourned.

The Valuation of Oxide of Iron for the Purification of Gas.

Mr. H. L. Greville, Chemist to the Commercial Gas Company, contributed the following to the *London Journal*:

THE recent trial of the *Swansea Gas Company v. Abbott and Co.*, and the subsequent article* by Mr. James Sutherland, have called attention to a subject which is of undoubted interest to all managers of gas-works, and suggests that it would be most desirable to substitute some different method of testing the value of various samples of oxide to that usually in vogue. In other words, the value of any particular sample is not expressed by the mere percentage of water, ferric oxide, and siliceous matter present. What is really required is the actual value of the material for purposes of gas purification, or, what is probably the same thing, the percentage of hydrated ferric oxide which is present. The ordinary analysis, of course, is a certain amount of guide; but not a complete one. The usual analysis will reveal the freedom of the sample, or the converse, from clay and siliceous matter—and will also show the percentage of moisture and the total percentage of ferric oxide—details always necessary in the formation of any opinion as to the merits or demerits of any particular sample; but there remains unsettled the important question as to how much of the total ferric oxide present is in the condition to be useful as an absorbent of sulphuretted hydrogen. It is more particularly with regard to this point that I wish to offer a few remarks; and I only regret that I have not as yet had the leisure to thrash the question out practically.

Firstly, with regard to the method of determining the percentage of hydrous oxide described by Mr. James Sutherland in his recent article. I cannot see how this process can give correct results, more especially as applied to "bog ores." It will be remembered that his process consists in placing a weighed quantity of the ore (presumably dried) in a combustion tube, to which is connected a calcium chloride tube; and after the ore has been heated to redness in a current of dry air, and the products passed through the calcium chloride tube, the increase in the weight of the latter is taken as representing the amount of combined water in the weight of oxide taken for the experiment. Now, this process could only give correct results in the absence of organic matter containing hydrogen—a condition never existing in Irish bog ores, one of the characteristics of which is the presence of peaty matter and vegetable fiber. Pure cellulose—the basis of woody fiber—contains up-

ward of 6 per cent. of hydrogen. Peat has been found to contain from 6.6 to 7.1 per cent. of hydrogen; and if we take a mean of (say) 5 per cent. these five parts of hydrogen would yield, on combustion, 45 parts of water. Therefore 10 per cent. of peaty matter in a sample of bog ore would give, on combustion, some 4½ parts of water; and the equivalent of this in hydrated ferric oxide of the formula $\text{Fe}_2\text{O}_3\cdot\text{H}_2\text{O}$ would be 44.5. Having given some thought to the matter, I do not, however, despair of a process being available for the correct determination of the percentage of hydrated ferric oxide as opposed to the anhydrous in any particular sample of oxide; and of thus affording a means of exactly valuing the material for gas-works purposes. The reaction which appears most promising upon which to found a process for the end in view is that between hydrated ferric oxide and sulphuretted hydrogen. This action occurs according to the following equations:—

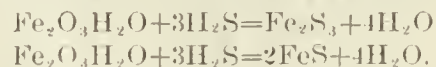

The former reaction, according to Mr. Lewis T. Wright, predominates. What I wish to call special attention to in the above equations, is that whichever action takes place, one molecule of $\text{Fe}_2\text{O}_3\cdot\text{H}_2\text{O}$, always reacts with three molecules of H_2S , and forms four molecules of water. It is also seen that of these four molecules of water, one is derived from the water of hydration of the $\text{Fe}_2\text{O}_3\cdot\text{H}_2\text{O}$; and the other three from the union of the hydrogen of the H_2S with the oxygen of the ferric oxide. The process I would therefore suggest is to place a weighed quantity of the dried and finely-powdered sample of oxide in a U-tube (preferably mixing it with some dry neutral material—such as sawdust or cocoanut fiber refuse), then to connect this tube to a carefully weighed calcium chloride tube, and pass a current of dry H_2S until the oxide is saturated. The calcium chloride tube could then be detached, a little dry air passed to displace the H_2S , and finally weighed. The increase in weight, divided by four, would give the amount of water present, in combination with Fe_2O_3 , in the same token. As one molecule of $\text{Fe}_2\text{O}_3\cdot\text{H}_2\text{O}$ in reaction with H_2S gives four molecules of water, the weight of the molecule of $\text{Fe}_2\text{O}_3\cdot\text{H}_2\text{O}$ —viz., 178—would give 72 parts by weight of water; and each part of water obtained would represent 2.472 parts of $\text{Fe}_2\text{O}_3\cdot\text{H}_2\text{O}$.

I see no practical reason why this process should not be a workable and fairly accurate one. Two things must, however, be taken for granted—viz., firstly, that the composition of the hydrated oxide present in the ore dried at 100° C. is $\text{Fe}_2\text{O}_3\cdot\text{H}_2\text{O}$; and, secondly, that H_2S , does not react with anhydrous oxide. An experiment I have recently made on this point shows that (contrary to general belief) a slight action does occur; but I believe it to be infinitesimal, and that it would not practically interfere with the accuracy of the proposed process.

There is another method of determining the value of any particular sample of oxide for gas purification which should be mentioned; and upon which (granting the two assumptions already stated) a calculation can be made as to the percentage of "active" oxide present. I allude to that proposed by Mr. Lewis T. Wright, and which consists in saturating a weighed quantity of the sample with H_2S , and either determining the amount of iron which has become sulphide by a special process, or revivifying the material by exposure to air, and subsequent estimation of the free sulphur in the usual way with carbon disulphide. The proportion of "active" oxide present can then be calculated on the basis that 96 parts of S equals 178 parts of Fe_2O .

There is no doubt that it is getting more desirable every day that there should be some acknowledged laboratory method by means of which the special suitability of any particular sample of oxide to gas purification purposes could be ascertained. Judging by my own experience, there is now a good deal of competition in the supply of oxide to gas works; and the most tempting bait is frequently held out to gas managers of samples at very moderate prices, and guaranteed to contain high percentages of ferric oxide. How much of the total percentage of ferric oxide is available for purification, is, however, generally an unknown quantity; and it is obvious, on a little reflection, that, if samples were submitted to a test capable of distinguishing between the "active" and "inactive" forms of ferric oxide, the opinion formed on a simple determination of the total ferric oxide present might be reversed, and that "the first might be last, and the last first."

Before concluding, I should like to draw attention to an inference which follows upon my experiment on the action of sulphuretted hydrogen on anhydrous ferric oxide. In this experiment a small

*See ante, p. 232.

quantity of the Gas Purification Company's oxide was ignited for some time, until all organic matter and water was expelled. The residue was then finely ground, mixed with sawdust, and the mass slightly moistened and placed in a tube. A current of H_2S was then passed, and blackening ensued, unaccompanied by any rise of temperature perceptible to the hand. The temperature of the mass had, however, risen (as shown by a thermometer) by about 15° Fahr. Now, once admitting that a slight action had taken place, the inference is that, on revivification and use a second time, the ferric hydrate formed from the oxidation of the sulphide would come into play, plus a further small installment of the anhydrous oxide; and thus after a time a material proportion of the anhydrous material would become efficient as an agent for gas purification. Does not this throw some light on the experience of so many gas managers with particular samples of oxide, which do not appear to work well until after being some time in use, and after having, consequently, undergone several sulphidings and revivifications? It would, in fact, seem that even anhydrous ferric oxide is not altogether devoid of power as a purifying agent, if employed in a finely-divided condition; but its action is not sufficiently expeditious to render its employment desirable where the active and hydrated material is so easily available. This is more particularly the case as the anhydrous ferric oxide is often hard and massive, so that even if active, its action would be limited by its general imperviousness, unless previously ground very fine and mixed with a large quantity of sawdust or other material to make it pervious to the gas; whereas most samples of hydrated oxide are comparatively light in structure, and readily broken. In the best Irish bog ores, we have the perfection of material as far as physical condition extends; for the ferric oxide is in a finely-divided condition, in a pervious peaty basis. There is also every reason to assume that, in carefully selected and collected samples, a large proportion of the total ferric oxide present is in the hydrated, and, therefore, active condition.

Finally, I will only add that I hope soon to be able to find time to make some experiments on different samples of oxide now in the market, as a practical contribution to an important question, I have thus far been able to do little but deal with theoretically.

Saccharin.

Edward D. Graville, F. C. S., in the course of a series of notes on saccharin, says:

The sample to which these notes refer represents, I believe, a portion of the first supply that has been offered to us as a commercial article, and may therefore be taken to represent the same as it at present occurs in commerce. I think it desirable to call attention to this fact, because of the wide difference I have seen in other samples obtained, I think, by special request some weeks ago, and which do not favorably correspond with the sample under consideration, being much more highly colored, and in comparison having a very strong odor. Saccharin now occurs as a very pale yellow, nearly white, amorphous powder, free from grittiness, but giving a distinct sensation of roughness when rubbed between the fingers. It is not entirely free from odor, but this is very slight, and not at all objectionable, reminding one of a very slight flavor of essential oil of almonds. Its taste is intensely sweet and persistent, which in a raw state is followed by a slight harshness upon the tongue and palate. The sweetness is very distinct when diluted to 1 in 10,000. Under the microscope it presents no definite form of crystallization. A temperature of 100° C., even if continued for some time, has no perceptible effect upon saccharin; it loses no weight, and undergoes no physical change. It fuses at a temperature of from 118° to 120° C., and at 150° C. forms a clear light yellow liquid, which boils a few degrees higher. At the latter temperature dense white fumes appear, and a condensation of tufts of acicular crystals (some well defined) is found upon the cool surface of the apparatus. These crystals, except for a slight sweetness of taste, correspond in characters and tests to benzoic acid. The sweet flavor, I think, may be due to the presence of a very small quantity of undecomposed saccharin, carried mechanically with the fumes. The escaping vapors, which are very irritable, and give a more decided odor of hydride of benzole than the powder itself, also communicate a very distinct sensation of sweetness to the back part of the palate. Heated over the flame, with free access of air, saccharin carbonizes and burns with a dull, yellow smoky flame, leaving a residue amounting to 0.65 per cent. of sodium salts. It does not reduce an alkaline copper solution, but, like glycerine, liberates boracic acid from borax, the latter salt dissolving saccharin readily in aqueous solution, due no doubt to a displacement of the boracic acid.

The strong acids, either hot or cold, show no characteristic color reaction; the compound enters solution at the boiling point of the acid, and in the case of hydrochloric, shows a white granular separation on cooling. Sulphuric acid develops an uncharacteristic light brown color.

The compound, like most of the organic acids, shows a characteristic reaction with ferro and ferrid cyanide of potassium. In the former case no change is perceptible until boiled, when a greenish-white turbidity appears with the liberation of small quantities of hydrocyanic acid. In the latter case also a trace of this acid is set

free, with the formation of a very distinct green solution, the latter reaction being very perceptible with a few drops of a 1 in 1,000 solution of saccharin in water. Heated with lime, very distinct odors of benzoic aldehyde are developed.

Saccharin possesses very decided acid properties, and combines readily with alkalis or alkaline carbonates, forming anhydro-ortho-sulphamine-benzoates of the same, in the latter case at the expense of the carbonic anhydride, causing strong effervescence. These combinations are very soluble in water, the alkaline carbonate thus forming a ready medium for the solution of this acid, which alone is so sparingly soluble. Another advantage of some importance is, that while the harshness of flavor perceptible in a simple solution of the acid is destroyed, the great sweetness appears to be distinctly intensified and refined.

The following shows the solubility of the saccharin in the various liquids quoted, all, with the exception of the boiling water, being taken at 60° F.:

Boiling water.....	0.60	parts per 100 by volume.
Cold water.....	0.20	" "
Alcohol .800.....	4.25	" "
Rectified spirit .838....	3.20	" "
Ether .717.....	1.00	" "
Chloroform 1.49.....	0.20	" "
Benzine.....	0.40	" "
Petroleum ether	insoluble.	

It is also sparingly soluble in glycerine and fixed oils, and to a greater or less extent in volatile oils. Benzoic aldehyde dissolves saccharin in large quantities.

The quantity of saccharin required to communicate an agreeable degree of sweetness, like sugar, differs with the material to be sweetened, but from half to one-and-a-half grains, according to taste, will be found sufficient for an ordinary breakfast cup full of tea or coffee infusion.

Difficult Soldering.

A mechanic tells us that if soft solder is to be handled as readily as the ox-hide mixture found in the carpenter's glue pot the mechanic must fit up the surfaces of the joint as nicely as the wood-worker when he is to glue up a frame on the miter. A gluing-up job that must have all the clamps in the shop brought to bear on the joint to squeeze out the glue and crowd the parts together may leave a mitered corner that will pass inspection, but the joiner who can pare down a joint that will fit over the entire surface is going to have a specimen of work that will not as much as show a seam. And so with a job of brazing; two rough surfaces can be brought together without as much as having them cleaned and not only covered over with a layer of borax but heaped up with pieces of glass, and the whole thing bound together with a bale of soft iron wire. A dam is needed for such purpose built up of clay around the seam to hold the liquid brass or "sweating" mixtures, till an affinity is manifested between the surfaces. There are workmen who cannot fill a box with Babbitt metal without first washing the box with alcohol and dusting over the surface with sal-ammoniac wherever a tinned surface is to be formed, and the remaining surface of the box covered with clay wash to protect it against the attack of the fused metal, and if they were to solder a joint that is to be carefully united the surfaces would be nicely fitted with a file and then cleaned thoroughly before bringing the parts together. A piece of tin foil will occupy about as narrow a space as may be asked for and cover the whole surface, and when the work is heated slowly in a fire the parts can be united so nicely that the joint will be almost invisible. This is one of the "kinks" that is brought into use when soldering on a vertical patch, or a patch that must stand in an upright position while it is to be united with a soldering iron. A saddle, which is only a flange coupling for a steam pipe that is to be sweat on to a vertical pipe, brings to mind that solder will not run up hill, and the spacings beneath the saddle must be draining themselves dry as soon as the parts are heated. A fit that almost any one can obtain will bring into play that clinging power that capillary attraction is allied with, and a solid joint is obtained with only the assistance of a Bunsen burner and a solution of hydrochloric acid and zinc. This solution, that the tinman ranks next to that of rosin, readily dissolves the oxide which is continually forming on the surface, and leaves a coating of zinc which the solder has a desire to adhere to. A burner of this kind is used not only for the high heat that it will give but for the convenience of raising temperature without coating the surface with soot, and can be used in almost any place about a building by conducting the gas through several lengths of 1-8 inch pipe. When the copper, known as the soldering iron, is to be made use of on this vertical class of work, or wherever the seam comes on the underside of the joint, the edge of the seam is left as sharp as possible. Beveling the patch on the underside the solder remains without much difficulty. Any one can solder across the upper edge and down each side, but where a workman is cramped for room, he won't get across the under side quite as convenient. By having a thin edge that leaves almost a flat surface to work on instead of a square corner, the solder will have a chance to flow down to the seam and under the joint without the unnatural attempt of running up hill to make the union, or coming the plastic dodge of wiping over the seam with plumber's solder. —*American Artisan.*

Distillation of Wood.

The *Scientific American* says that the Cadonia Chemical Company, Cadonia, N. Y., has several establishments in that vicinity for the distillation of wood, which has now become an extensive and important industry.

Almost any of the harder varieties of wood will answer, but those chiefly found and used by this Company in the region it now occupies are birch, beech and maple. Pine, hemlock and soft woods will not answer. The general operations and products of the Company are as follows:

Contracts are made with the neighboring farmers for the purchase of standing wood, on which an agreed amount is paid in advance, balance payable as fast as the wood is cut by the Company. The wood is delivered at the works in ordinary four-foot lengths, and is then piled in the distilling retorts, of which there are in the Cadonia still-house 24 pairs. These retorts consist of cast iron, somewhat in the form of a steam boiler, about 10 ft. long and 4½ ft. diameter, having a large manhole at one end, and condensing exit neck at the other end. When a retort is filled with wood the manhole is closed and sealed; a slow fire is then started under the retort. The first products of the distillation, consisting of alcoholic vapors, are passed through a condensing worm, and the liquid thus produced is subsequently redistilled, and this product then sold. Most of it goes to Binghamton, N. Y., where it is refined and put on the market as wood alcohol.

The second products of the distillation, consisting of acetic vapors, are condensed as before described, and the liquid is mixed with lime, thorough mixture being effected by mechanical means, thus producing acetate of lime—used in cloth printing works. The crude acetate is placed above the retorts on racks, where it is dried, and is then ready for market.

The third products of the distillation, consisting of tarry matters and naphthas, are shipped as produced and subsequently refined.

The last products, consisting of heavy tars, are used at the works as fuel. When the distillation is finished, there remains within the retorts a mass of clean and beautiful charcoal ready for market, and all of it is sold to the steel makers. Most of it goes to Troy, N. Y., where it is chiefly used in the production of fine steel.

The principal fuel used in these works is bituminous coal, which, together with the crude lime required, is brought to the works by railway.

We are indebted to a correspondent who resides in the vicinity for these particulars, which are only intended to convey a very general idea of the mode in which some portions of the forests in Delaware County, N. Y., are now being utilized.

The tanning of leather has been and still is a leading industry in this region. This involves the use of large quantities of bark, the trunks of the trees being sawed up and converted into lumber.

Many of the hills in the above vicinity are underlaid with bluestone, and there are several fine quarries of this noble building material.

Combustion.

The *Mechanical Engineer* explains that the combustion of coal is nothing more nor less than its combination with oxygen gas. When a fuel of any kind combines with oxygen heat is produced. Why fuel should combine with oxygen no one can tell. It is one of nature's secrets. The chemist tells us that the oxygen and the fuel have an "affinity" for each other. But when this statement has been made we are no nearer to understanding why combination takes place than we were before. In text books nothing will be found as to why heat is produced by the combination. On this point an all but universal silence prevails.

We are told, however, by a few writers of the old school, that heat energy was stored up in the coal millions of years ago by the sun, and that this heat energy is liberated when the coal combines with oxygen. This is absurd. It will not be out of place to give here an explanation which is consistent with facts, and therefore appears to be satisfactory.

All bodies, substances, gases and liquids are supposed to be composed of multitudes of particles or molecules of almost inconceivable smallness, and these are supposed to be in motion among themselves. This motion is heat—that is to say, heat is neither more nor less than a kind of motion, and this internal vibration can be transmuted into perceptible mechanical movement; or, on the other hand, mechanical movement can be converted into the invisible motion called heat. How the change takes place no one knows, but the change is none the less a fact. Now, the difference between a solid and a gas is that the motion of the parti-

cles or the molecules of the gas is much greater in extent than is the motion of the particles of the solid. Also some gases have a greater range of motion than other gases. If by any means we can take the motion out of gas, say, by compressing it into a vessel the sides and ends of which reduce the range of movement, then, as nothing is lost in nature, the invisible and insensible motion of the gas, which it has lost, reappears as heat in a sensible form, and we find that the sides of the vessel become hot. Now, the oxygen which combines with coal has a very considerable range of internal motion, but when the oxygen has combined with the coal another gas, known as carbonic acid gas, is produced; and the particles of this gas having a much smaller range of motion than the particles of the oxygen have, the difference appears in the form of heat.

It is not unnecessary to tell readers that coal is not always the same. It is composed of various substances and gases. The principal are carbon, hydrogen, oxygen, and certain impurities which make the ash with which we are so familiar. The carbon, hydrogen and oxygen are "elements;" that is to say, they are not composed of separate substances combined together. They cannot be split up into anything else. In 1,000 pounds of anthracite coal there are about 915 pounds of carbon, 35 pounds of hydrogen, and 26 pounds of oxygen. In a good bituminous or North-country coal there will be 800 pounds of carbon, 54 pounds of hydrogen, and 16 pounds of oxygen. The difference between the sum of these quantities and 1,000 pounds is matter entirely non-combustible which appears as ash. Of course, there are an infinite number of variations in the proportions which the constituents of coal bear to each other, but the figures we have given fairly represent good Welsh and good North-country coals respectively.

The air we breathe is composed of two gases—oxygen and nitrogen. The latter appears to have no effect whatever on human life and combustion. It serves to dilute the oxygen. The two gases are mixed; they are not in chemical combination. By weight, approximately, 36 pounds of air contain 28 pounds of nitrogen and 8 pounds of oxygen. In bulk they are mixed in the proportion of, roughly, 4 to 1. Four cubic feet of nitrogen and one of oxygen making five cubic feet of air.

The Indian Petroleum Fields.

According to those in authority, it is said that Mr. Townsend, the petroleum expert in charge of the Government oil wells at Kattan, in Beluchistan, 50 miles from Sibix, will begin in a few days the deep borings recently decided upon. The commencement of the work has been delayed by the drought, which has prevailed in that part of the country; but the machinery is now in place, and the deep borings will not be much longer delayed.

The indications already obtained by moderate borings show that at a depth of 2,500 feet an annual yield of 50,000 barrels can be obtained when once the live oil has been reached. It will take, it is obvious, some time to do this, and in the mean time the question arises whether the Indian Government is wise in sinking so much money on the relatively insignificant oil fields of Beluchistan while leaving the enormous deposits of Burmah disregarded and untouched. If, from a depth of 200 feet or 300 feet these Burmese oil fields yield more oil than the Beluchistan wells will afford, even when the boring rod has penetrated ten times that distance, the question naturally occurs, why not make a few borings at Yenangyoung to 500 feet or so, instead of driving wells 2,500 feet deep, which, even if successful, will yield only a trifling amount of oil. If the Burmese fields proved as copious as those at Baku—and up to now the surface workings have been sufficiently rich to suggest that they are—then it would be better to work the cheap abundant oil there and send it round to the Indus in tank steamers for use on the Punjab lines, than to persist in the deep borings in the scanty oil field of Beluchistan. The way that the oil deposits of Burmah are being shelved by the State does not reflect credit on the Indian administration.

It is said that the incandescent electric system hitherto used for the illumination of the Pittsburgh (Pa.) Union Railway Depot is to be changed to that of the Westinghouse alternating type.

THE trouble over the site for another gas works for Owensboro', Ky., previously mentioned in these columns, has been dissipated—finally, let us hope—by the purchase of a plot of ground on Third street. The Council has issued the necessary building permit.

THE residents of Victoria, Texas, are anxious to have that town lighted by electricity.



A. M. CALLENDER & CO.,
PROPRIETORS.

Editor—JOS. R. THOMAS, C.E.
Asst. Editor—T. J. CUNNINGHAM.
Manager—C. E. SANDERSON.

PUBLISHED ON THE 2ND AND 16TH OF EACH MONTH
At No. 42 Pine Street, New York.

This is a recognized official organ of—
LIGHT, HEAT, STEAM, WATER-SUPPLY,
VENTILATION, SANITARY IMPROVEMENT
AND GENERAL SCIENCE.

TERMS

SUBSCRIPTION—Three Dollars per annum, in advance.

AGENTS

NEW YORK—AMERICAN NEWS CO. 39 and 41 Chambers St.
BOSTON—S. M. PETTENGILL & Co., 6 State Street.
PHILADELPHIA—PRATT & Co., Corner 9th and Arch Streets.
England—C. W. HASTINGS, 22 Buckingham St., LONDON, W. C.
Germany—B. WESTERMANN & Co., of New York

WEDNESDAY, NOVEMBER 16, 1887.

The Market for Gas Securities.

The city market for gas shares, notably Consolidated, has kept pace with the better tone now prevailing in general speculation. Consolidated, at time of writing (noon, Oct. 14), is bid for at 75, and perhaps the shorts will soon realize a smart shock instead of realizing any profit. They have, however, like the grasshoppers, been dancing all summer, consequently a short period of rest will prepare them all the better for a lengthy lethargic condition. Perhaps the lethargic symptoms may finally culminate in a sleep of the sort that "knows not waking;" for, judging from reliable advices in regard to the business now being done by the Company, and taking into consideration the prospects for the winter, we would not be surprised to see Consolidated stock selling at 85 before the first day of February. Some speculation is being indulged in concerning the declaration of the dividend, the time for which is close at hand. In all probability this will be at the rate of 4 per cent. per annum, although some prognosticators look forward to a half per cent. increase. Equitable keeps steady in the neighborhood of 115, and but little of the stock is offered. Mutual is somewhat stronger, and to us it looks cheap at the figure given. Brooklyn shares are holding their own, notably Williamsburgh. This stock is, beyond doubt, worth more than the quoted prices, and the same remark, perhaps with greater force, applies to Nassau. The St. Louis situation presents no material change, while Chicago matters are more muddled than ever. The Baltimore gas shareholders are about to ratify the terms of the recent agreement, the meetings to be held on the 6th prox. We note that the Chesapeake capital is to be reduced to \$2,498,000. Louisville (Ky.) shares are weaker. Some inquiry has recently been made for Washington (D. C.) shares.

The Crompton Shadowless Arc Light Pole.

In the ordinary mode of suspending an arc lamp intended for the illumination of external areas or spaces the lamp necessarily casts a dense shadow of the supporting pole on one side. To overcome this defect Mr. Crompton has perfected an ingenious artifice which he calls, and with reason, a "shadowless pole," an illustration of his device being herewith given.



The lamp is carried by a steel bracket right above the post, and when the operation of lowering, for the purpose of "trimming," needs to be performed, the lamp is let down at the side of the post by a simple although effective arrangement. By this means the shadow is prevented, and the illumination caused to be symmetrical on the horizontal plane.

A LINE FROM MARLBORO', MASS.—Last February we took occasion to say that Mr. Wm. Anderson had resigned his berth at Chelsea, Mass., in order to assume the Superintendency of the Marlboro' gas plant. His hand apparently has not lost its cunning, because, on Oct. first, the Directors of the Company saw their way clear to make a decided cut in gas rates. Prior to the date mentioned the gross charge was \$3 per thousand, whilst the new schedule calls for the payment of \$2.50. The wisdom of the concession was proved by an immediate increase in sendout, the returns showing the gain (comparing Oct., '86 with the same month in '87) to have been something over 100,000 cubic feet. Supt. Anderson has just completed the replacing of about 1,000 feet of 3-inch pipe on Main street, having substituted a 6-inch main therefor. We knew the ex-Chelsea member would be heard from soon, and that his voice would have the proper ring.

IS WAS AS IT SHOULD BE.—Some of the Montreal (Can.) gas consumers have been loud in

their assertions that the gas supplied them was not up to the standard of illuminating power and purity required by the law; but, as is usual with such complainers, their complaints were not in accordance with the facts. Mr. Aubin, the local Gas Inspector, in answer to the objectors, has furnished averages of his official tests for the months (June 30 to Oct. 31) in which the clamor was loudest, and these show the illuminating power to have been 1.5 candles in excess of the statutory demands. In the item of purity, also, the gas was fully up to standard. The Montreal Company uses iron sponge eked out with lime in its purifiers.

THE Kerr Murray Manufacturing Company is under contract to construct a new 8-inch plant complete to the order of the Charlottesville (Va.) Gas Company. The items include retort house roof, benches, rotary exhauster, annular and multitubular condensers, washer, purifiers, boiler, station meter and street main governor,

Gas Stocks.

Quotations by Geo. W. Close, Broker and Dealer in Gas Stocks.

16 WALL ST., NEW YORK CITY.

NOVEMBER 16.

All communications will receive particular attention.

The following quotations are based on the par value of \$100 per share.

	Capital.	Par.	Bid	Asked
Consolidated.....	\$35,430,000	100	75	—
Central.....	440,000	50	30	—
“ Scrip.....	220,000	—	47	57
Equitable.....	2,000,000	100	—	115
“ Bonds.....	1,000,000	—	113	115
Harlem, Bonds.....	170,000	—	—	—
Metropolitan, Bonds....	658,000	—	110	113
Mutual.....	3,500,000	100	91	95
“ Bonds.....	1,500,000	1000	101	—
Municipal, Bonds.....	750,000	—	—	—
Northern.....	125,000	50	30	—
“ Scrip.....	108,000	—	—	—
Yonkers.....	—	50	—	80
Richmond Co., S. I.	300,000	50	50	—
“ Bonds.....	12,000	—	—	—
Gas Co's of Brooklyn.				
Brooklyn.....	2,000,000	25	101	103
Citizens.....	1,200,000	20	50	—
“ S. F. Bonds....	320,000	1000	—	103
Fulton Municipal.....	3,000,000	100	128	130
“ Bonds....	300,000	—	—	106
Peoples.....	1,000,000	10	58	61
“ Bonds (5's).....	368,000	—	97	—
“ “ (6's).....	94,000	—	100	—
Metropolitan.....	1,000,000	100	77	80
Nassau.....	1,000,000	25	90	95
“ Ctfs.....	700,000	1000	95	100
Williamsburgh.....	1,000,000	50	104	108
“ Bonds... ..	1,000,000	—	111	—
Out of Town Gas Companies.				
Boston (Mass.) Gas Co.	2,500,000	500	220	—
Buffalo Mutual, N. Y....	750,000	100	90	95
“ Bonds... ..	200,000	1000	95	100
Citizens, Newark.....	1,000,000	50	140	145
“ “ Bonds.	45,000	—	—	—
Chicago Gas Trust.....	25,000,000	100	39	40
Cincinnati G. & C. Co..	6,000,000	100	182½	185
Consolidated, Balt.....	6,000,000	100	62½	—
“ Bonds....	3,600,000	—	107	107½
Chesapeake, Balt.....	1,000,000	100	90	—
“	1,000,000	—	100	102
Consumers Toronto....	1,000,000	50	192	—
Central, S. F., Cal.....	—	—	—	84
Capital, Sacramento, Cal.	—	—	57½	60
Hartford, Conn.....	750,000	25	140	142
Jersey City.....	750,000	20	168	—
Laclede, St. Louis, Mo.	2,000,000	100	125	—
Louisville, Ky.....	2,570,000	50	122	127
Little Falls, N. Y.....	50,000	100	95	100
“ Bonds	25,000	—	100	103
Montreal, Canada.....	2,000,000	100	220	221

Advertisers Index.

GAS ENGINEERS.	
Jos. R. Thomas, New York City	344
Wm. Henry White, New York City	344
Wm. Mooney, New York City	344
William Gardner, Pittsburgh, Pa.	344
GAS WORKS APPARATUS AND CONSTRUCTION.	
James R. Floyd, New York City	347
T. F. Rowland, Greenpoint, L. I.	347
Delly & Fowler, Phila., Pa.	347
Kerr Murray Mfg. Co., Fort Wayne, Ind.	346
Stacey Mfg. Co., Cincinnati, Ohio	347
Bartlett, Hayward & Co., Baltimore, Md.	337
Morris, Tasker & Co., Limited, Phila., Pa.	346
Davis & Farnum Mfg. Co., Wal'tham, Mass.	288
R. D. Wood & Co., Phila., Pa.	346
Bouton Foundry Co., Chicago, Ills.	317
Smith & Sayre Manufacturing Co., New York City	347
PROCESSES.	
National Gas Light and Fuel Co., Chicago, Ills.	338
American Gas Improvement Co., Pittsburgh, Pa.	336
GAS AND WATER PIPES.	
Gloucester Iron Works, Phila., Pa.	344
Melfert Foundry and Machine Co., Reading, Pa. (John Fox, Selling Agent, N. Y.)	344
Cincinnati and Newport Iron and Pipe Co., Newport, Ky.	344
Ohio Pipe Co., Columbus, Ohio	344
Pancoast & Rogers, New York City	344
M. J. Drummond, New York City	344
Wells Rustless Iron Co., New York City	344
R. D. Wood & Co., Phila., Pa.	346
GAS ENGINES.	
Schleicher, Schumm & Co., Phila., Pa.	352
Clerk Gas Engine Co., Phila., Pa.	339
RETORTS AND FIRE BRICK.	
J. H. Gantier & Co., Jersey City, N. J.	342
B. Kreischer & Sons, New York City	342
Adam Weber, New York City	342
Lafede Fire Brick Works, St. Louis, Mo.	342
Brooklyn Retort and Fire Brick Works, Brooklyn, N. Y.	342
Borgner & O'Brien, Phila., Pa.	342
James Gardner, Jr., Pittsburgh, Pa.	342
Henry Maurer & Son, New York City	342
Chicago Retort and Fire Brick Works, Chicago, Ills.	342
Baltimore Retort and Fire Brick Co., Baltimore	342
Oakhill Gas Retort and Fire Brick Co., St. Louis, Mo.	342
Evens & Howard, St. Louis, Mo.	343
Cincinnati Gas Retort and Fire Brick Works, Cincinnati, O.	343
Emil Lenz, New York City	343
SCRUBBERS AND CONDENSERS.	
G. Shepard Page, New York City	345
R. D. Wood & Co., Phila., Pa.	346
REGENERATIVE FURNACES.	
Bartlett, Hayward & Co., Baltimore, Md.	337
Fred. Bredel, New York City	343
GAS GOVERNORS.	
T. C. Hopper, Phila., Pa.	340
Connelly & Co., New York City	339
CEMENTS.	
C. L. Gerould & Co., Brooklyn, N. Y.	342
GAS ENRICHERS.	
Standard Oil Co., Cleveland, Ohio	348
GAS METERS.	
Harris, Griffin & Co., Phila., Pa.	350
American Meter Co., New York and Philadelphia	351
The Goodwin Gas Stove and Meter Co., Philadelphia, Pa.	351
Hefme & McIlhenny, Phila., Pa.	351
D. McDonald & Co., Albany, N. Y.	351
Nathaniel Tufts, Boston, Mass.	350
Maryland Meter and Manufacturing Co., Baltimore, Md.	350
EXHAUSTERS.	
P. H. & F. M. Roots, Connersville, Ind.	338
Smith & Sayre Manufacturing Co., New York City	347
Wilbraham Bros., Philadelphia, Pa.	339
Connelly & Co., New York City	339
GAS COALS.	
Penn Gas Coal Co., Phila., Pa.	349
Perkins & Co., New York City	348
Newburgh Orrel Coal Co., Baltimore Md.	349
Despard Coal Co., Baltimore, Md.	349
Chesapeake and Ohio R.R. Coal Agency, N. Y. City	349
Westmoreland Coal Company, Phila., Pa.	349
Monongahela & Peters Creek Gas Coal Co., Pittsburgh, Pa.	349
CANNEL COALS.	
Perkius & Co., New York City	348
J. & W. Wood, New York City	348
VALVES.	
Ludlow Valve Manufacturing Co., Troy, N. Y.	340
John McLean, New York City	340
Chapman Valve Manufacturing Co., Boston, Mass.	310
R. D. Wood & Co., Phila., Pa.	346
The Combination Gas Machine Co., Detroit, Mich.	335
PURIFYING MATERIAL.	
S. H. Douglas, Anu Arbor, Mich.	343
Connelly & Co., New York City	339

ENGINES AND BOILERS.	
Jarvis Engineering Co., Boston, Mass.	339
GAS LAMPS.	
The Siemens-Lungren Co., Philadelphia, Pa.	345
G. Shepard Page, New York City	292
Aldo-Carbon Light Co., Newark, N. J.	333
Standard Gas Lamp Co., Phila., Pa.	343
PURIFIER SCREENS.	
John Cabot, New York City	335
Geo. A. Mills, Baltimore, Md.	340
GAS STOVES.	
American Meter Co., New York and Philadelphia	344
The Goodwin Gas Stove and Meter Co., Phila. Pa.	304
The Combination Gas Machine Co., Detroit, Mich.	335
Dinsmore Manufacturing Co., Boston, Mass.	435
STREET LAMPS.	
J. G. Miner, Morrisania, New York City	335
Bartlett Street Lamp Mfg Co., New York City	343
BURNERS.	
C. A. Gefroer, Phila., Pa.	418
STEAM BLOWER FOR BURNING BRESE.	
H. E. Parson, New York City	340
GASHOLDER TANKS.	
W. C. Whyte, New York City	346
COKE CRUSHER.	
C. M. Keller, Columbus, Ind.	349
ELECTRICAL APPARATUS.	
Waterhouse Electric & Manufg Co., Hartford, Conn.	336

FOR SALE.
ONE-QUARTER OR ONE-HALF INTEREST
IN A FIRST-CLASS GAS & ELECTRIC
LIGHT PLANT,
 In one of the most prosperous cities of Texas. To include the control of its management, and friendship and goodwill of its present owners, who do not wish to sell out entirely. Address 681-2 "S. J. W.," care this Journal.



FOR HEATING rooms of any size. Perfect combustion. No injurious odors to be carried away by a chimney. Warranted odorless, or the purchase money refunded. DINSMORE MFG. CO., 28 Kneeland Street, Boston, Mass. Send for Catalogue.

SITUATION WANTED
As Superintendent of Gas Works.

Has had many years' experience. Best of references. Address 682-1 "A. M.," care this Journal.

Position Wanted,

By a young man (22)

As Superintendent of a Gas Works.

Understands thoroughly the manufacture and distribution of coal and water gas, and is also a graduate chemist of the School of Mines, N. Y. Address R. E. SLADE, Yonkers, N. Y.

ENGLISH
"Journal of Gas Lighting."

Issued weekly. New volume commences Jan. 1, 1887. Price, \$7 per annum. Subscriptions taken by **CHARLES NETTLETON, Agent for U. S.,** No. 115 BROADWAY, N. Y. CITY.



Are adapted for use of Streets, Parks, Depots, Ferries, & Private Grounds.

WITH POSTS OR BRACKETS.

Jacob G. Miner,
 No. 823 Eagle Ave., New York, N. Y.

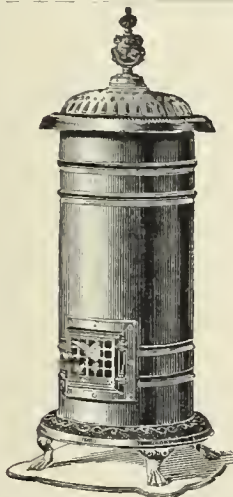

GAS STOVES

OF EVERY DESCRIPTION, FOR HEATING, COOKING, LABORATORY, AND MECHANICAL PURPOSES.

Weber Straight-Way Valves,

FOR GAS, STEAM, AND WATER.

Send for Catalogue "G."

Correspondence Solicited.

THE COMBINATION GAS MACHINE CO.,

Detroit, Mich.

Windsor, Ont.

163 Maiden Lane, N. Y. City. 87 Dearborn St., Chicago, Ill.

CHURCH'S REVERSIBLE TRAY



For Purifiers and Scrubbers.

OVAL OR RECTANGULAR SLATS.

FOR LIME OR IRON SPONGE.

MALLEABLE IRON CROSS BARS.

Strongest! Most Durable!
Most Easily Repaired!

MANUFACTURED BY

JOHN CABOT,

306 to 310 Eleventh Ave., N. Y. City.



Patented July 9, 1878, and Feb. 5, 1884.

Used by the principal Companies in every State of the Union. Price List on application.

THE ALBO-CARBON LIGHT.

THIS SYSTEM HAS SHOWN ITSELF IN THOUSANDS OF CASES—IN HALLS, CHURCHES, PICTURE GALLERIES, CONCERT HALLS, RESTAURANTS, BANKS, CLUBS, STORES, OFFICES, and PRIVATE RESIDENCES—TO BE THE

Best Adapted and Most Successful Method of Gas Lighting Ever Offered.

The **SOFTNESS AND PURITY OF THE LIGHT** make it most desirable for Office and Household Uses. Its **BRILLIANCY** and **POWER** render it unrivaled for lighting Halls, Churches, etc. Its **ECONOMY** secures for it general favor wherever used.

NOTICE.—Suits are pending in the United States Circuit Courts in Illinois and Pennsylvania against various parties for infringement of our Letters Patent No. 247,925, dated October 4, 1881, and No. 333,862, dated January 5, 1886. The first of these suits has come up for hearing, and an injunction has been granted therein. The second of said suits has not yet been reached for hearing. All persons are cautioned against manufacturing, selling, or using any apparatus or material which infringes our patents. We intend to prosecute all parties infringing patents owned by us.

ALBO-CARBON LIGHT CO. (Sole Manufacturers for the United States) Main Office, Newark, N. J.



Illuminating Gas from Natural Gas.

THE AMERICAN GAS IMPROVEMENT CO., Limited, 95 Fifth Avenue, Pittsburgh, Pa.

Erect Apparatus for the treatment of Natural Gas for an Illuminant under the

McKAY-CRITCHLOW SYSTEM.

Satisfaction in Economy and Quality Guaranteed.

Apparatus adapted to the manufacture of Water Gas, without any change whatever, should it be desirable to do so on account of Natural Gas playing out. Apparatus erected or Licenses sold at the following Works.

Pittsburgh Gas Works, J. H. McElroy, Engr.
Allegheny Gas Works, Robt. Young, Engr.
East End Gas Works, W. H. Denniston, Engr.
West Pittsburgh Gas Works, E. C. Critchlow, Supt.
Beaver Falls Gas Works, H. F. Dillon, Supt.
Titusville Gas Works, E. T. Roberts, Treas.
Salamanca, N. Y.
Jamestown, N. Y.
Meadville, Pa., Wm. Reynolds, Prest.

Warren, Pa., S. S. Franklin, Supt.
Franklin, Pa., C. W. Gilfillan, Prest.
Oil City, Pa.
Erie Gas Co., Erie, Pa., W. H. Hill, Engr.
Greensburg, Pa., Jas. C. Clarke, Prest.
Sewickley, Pa., J. W. Forbes, Supt.
Bellaire, Ohio, John Ferguson, Supt.
New Castle, Pa., D. T. Flick, Supt.
Corry, Pa.

Sharon, Pa., S. Perkins, Prest.
Fort Scott, Kansas, L. K. Scofield, Owner.
Fostoria, Ohio, Jos. Gwynn, Supt.
Emporia, Kansas.
Tiffin, Ohio.
Wellsville, Ohio.
Brownsville, Pa.

COMPETITION!

Closed Circuit Versus Open Circuit!

During the month of September a Waterhouse (Closed Circuit) plant, of 185 2000-C.P. lights, consumed **\$50 LESS COAL** than a plant of 150 2000-C.P. lights of a well-known system (Open Circuit), with which it is competing.

185 TO 150 IS THE PEOPLE'S VERDICT!

Fine, Large, Steady Lights! Instantaneous Automatic Regulation!

It Costs No More to Buy the Best.

THE WATERHOUSE ELECTRIC AND MFG. COMPANY,

Factory, Colt's West Armory.

Hartford, Conn.

To All Whom It May Concern!

The **SIEMENS-LUNGREN COMPANY** hereby warns the public against the use of various infringing Regenerative Gas Lamps which are offered for sale. This Company has heretofore delayed bringing suit to enjoin the manufacture or importation of such infringing lamps, solely because of the practical worthlessness of the infringing devices; and although, in each instance, they infringe some one or more of the various patents owned or controlled by this Company, they have fallen into disuse sooner than any suit could be brought to a hearing. As, however, the introduction of these infringing lamps has tended to discredit the practicability of our Company's system of regenerative gas lighting, we have instructed our Attorneys, Messrs. Geo. Harding, C. S. Whitman, and Silas W. Pettit, to give notice that legal proceedings will in future be taken against all such infringers.

THE SIEMENS-LUNGREN CO., 21st St. & Washington Av., Phila., Pa.

BARTLETT, HAYWARD & CO.

Baltimore, Md.

Munich Regenerative Furnace, System Drs. Schilling & Bunte.

Greatest durability; minimum of attention; complete distillation in 3½ hours; 10 to 13 pounds of coke to hundred-weight of coal; no clinker; no carbonic oxide in regenerative flues.

TWO AND THREE-LIFT TELESCOPIC GASHOLDERS,

With Wrought Iron Tanks, constructed above ground, of any magnitude.

Condensers, Scrubbers, Purifiers, Bench Castings, Roofs, Boilers, Etc.

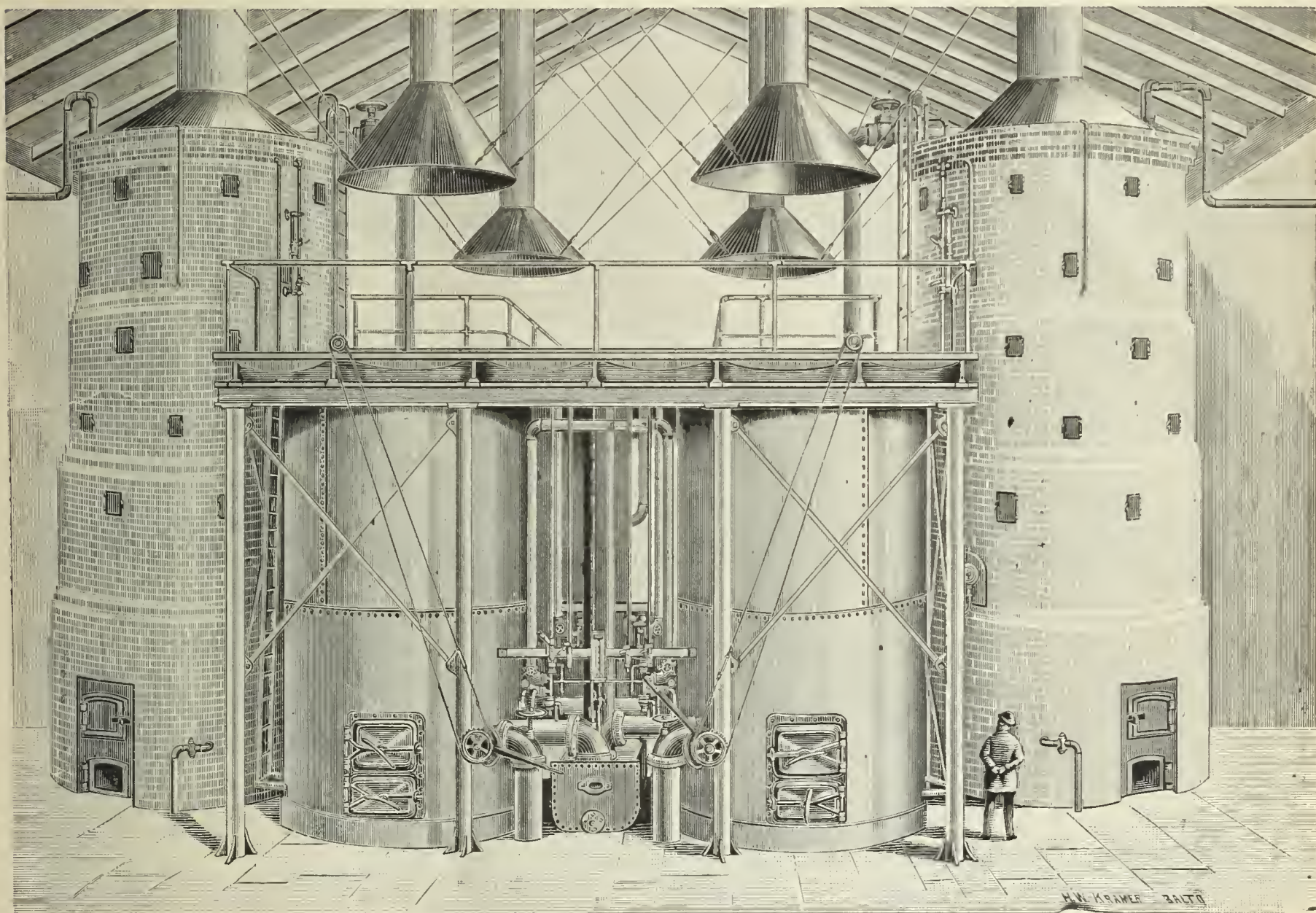

The Wilkinson Water Gas Process.

Introducing the Munich Regenerative Furnace for Coal Gas, we find on the part of many Gas Companies the desire to combine to a greater or less extent an efficient system of making high candle power Water Gas; and with a view of enabling this to be done WITHOUT EXCESSIVE CHARGES FOR PATENT RIGHTS, ETC., we have acquired, by purchase, the exclusive right to construct all the Water Gas Apparatus under the valuable "Wilkinson" Patents.

The results obtained by this Process are far better than those obtained by any other apparatus, especially where an illuminating gas of high candle power or a fuel gas of intense temperature is required.

The Process is uninterrupted, making gas of uniform quality and quantity. Its greatest advantages are maximum production with minimum material and labor, combined with great durability of apparatus.

The Process is in successful operation at the works of the N. Y. Mutual Gas Company, New York; Consolidated Gas Company, Baltimore, Md.; the Hudson County Gas Light Company, of Hoboken, N. J.; and at Rye, N. Y.

We shall be glad to give further detailed information upon application.

Sole Agents for the Celebrated Hazelton Boiler.

BARTLETT, HAYWARD & CO.

EXHAUSTERS.

EXHAUSTERS.

PROCESSES.

NATIONAL GAS LIGHT AND FUEL COMPANY,

No. 218 La Salle Street, Chicago.

THE SPRINGER SYSTEM

OF

Fuel and Illuminating Water Gas Works.

REFERENCES.

People's Gas Light and Coke Co.....	Chicago, Ill.	Mankato Gas Light Co.....	Mankato, Minn.
Elgin National Watch Co.....	Elgin, Ill.	Minneapolis Gas Light and Coke Co..	Minneapolis, Minn.
C. R. I. & P. R. R. Shops.....	Chicago, Ill.	Lima Gas Light Co.....	Lima, Ohio.
Decatur Gas Light and Coke Co.....	Decatur, Ill.	Bellevue Water and Fuel Gas Light Co.....	} Bellevue, Campbell County, Ky.
Niles Gas Light Co.....	Niles, Mich.	Bucyrus Gas Light and Fuel Co.....	
Newton Illuminating Co.....	Newton, Kansas.	Morris Gas Co.....	Morris, Ill.
Wellington Light and Heat Co.....	Wellington, Kansas.	Los Angeles Gas Co.....	Los Angeles, Cal.
Chippewa Falls Gas Light Co.....	Chippewa Falls, Wis.	San Diego Gas Fuel and Electric Lt. Co.....	San Diego, Cal.
Elkhart Gas Light and Coke Co.....	Elkhart, Ind.	Jackson National Gas Co.....	Jackson, Mich.
Madison City Gas Light Co.....	Madison, Wis.	Sioux Falls Gas Co.....	Sioux Falls, Dak.
South Bend Gas Light Co.....	South Bend, Ind.	Dakota Gas and Fuel Co.....	Grand Forks, Dak.
Sheboygan National Gas Co.....	Sheboygan, Wis.	St. Johns Mutual Gas Co.....	St. Johns, Mich.
Salina Gas Light Co.....	Salina, Kansas.	Stillwater Gas Light Co.....	Stillwater, Minn.
The Rathbun Co.....	Deseronto, Prov. Ont.	St. Paul Gas Light Co.....	St. Paul, Minn.
Jefferson City Gas Light Co.....	Jefferson City, Mo.		

GUARANTEED ESTIMATES of Cost of Gas Furnished on Application.

ROOTS' NEW GAS EXHAUSTER.

St. Louis, Mo.,
March 21, 1887.

Messrs. P. H. & F. M. Roots, Connersville, Ind.:
Dear Sirs—In 1872 one of your No. 5 Exhausters was placed in these works, and worked satisfactorily. In March, 1885, it was replaced by one of your No. 6 Exhausters. The latter has been in almost constant use the past two years, has worked up to all my expectations, and is to-day in apparently as good condition as when first set up. It has not cost one cent for repairs in all that time. I have also

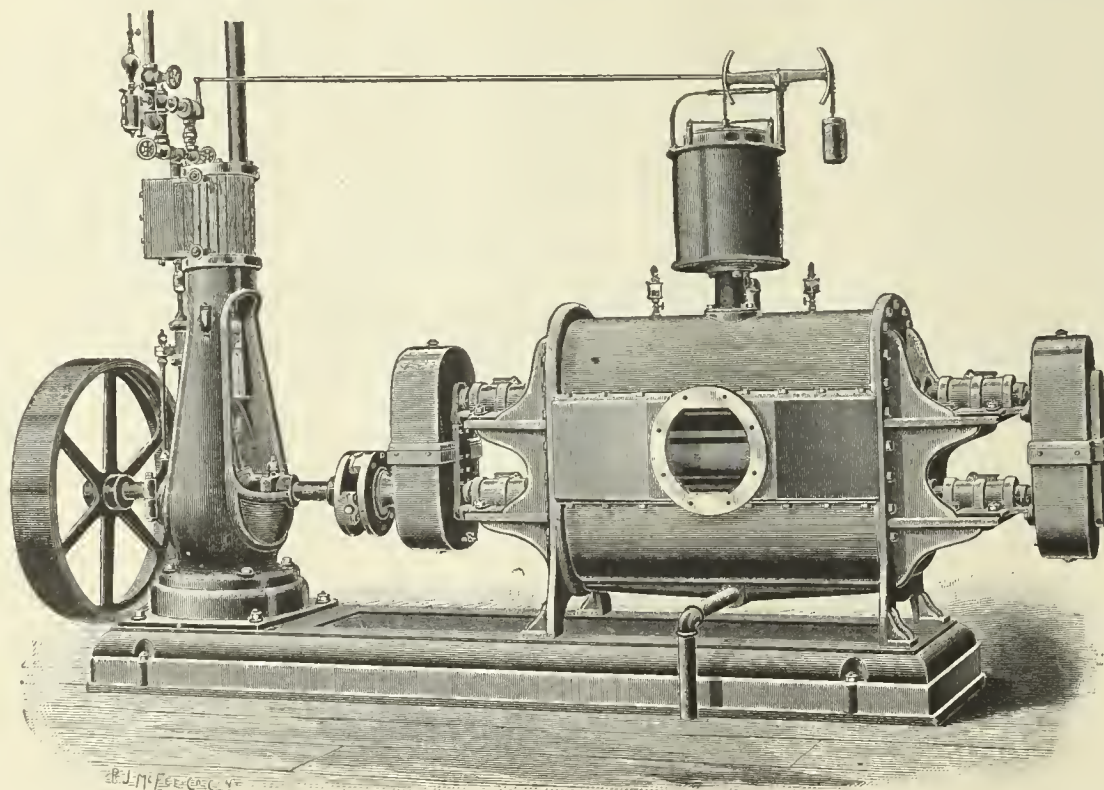

had one of your No. 1 Exhausters, with Engine on same bed-plate, fitted with your valves and Huntoon Governor, placed in a small works under my control, and in its operation it seems as near perfection as I ever expect an Exhauster to become. Without in the least disparaging Exhausters of other makes, I may say that your Exhauster may be safely recommended as unsurpassed by any other, to those requiring such machines.

Yours respectfully,
FREDERIC EGNER,
Eng. and Supt.

CONSTRUCTED ON ENTIRELY NEW PRINCIPLES.

THE ONLY EXHAUSTER MADE IN WHICH

The Internal Operating Parts Consist of Only Two Pieces, Each Cast Entire in One Piece.

Send for Descriptive Catalogue and Price List.

P. H. & F. M. ROOTS, Patentees and Manufacturers, **CONNERSVILLE, IND.**

S. S. TOWNSEND, Gen. Agt., 22 Cortlandt St., N. Y. COOKE & CO., Selling Agts., 22 Cortlandt St., N. Y.

CONNELLY & CO., LTD.,

SOLE MANUFACTURERS OF THEIR PATENTED SPECIALTIES.

"IRON SPONGE." Saves money, saves labor, and is the most efficient purifying agent ever offered as a substitute for lime. Now used in every State in the Union, and purifying daily over twenty-five million cubic feet. Should be used in every gas works. Its own saving will pay for it many times over.

AUTOMATIC GOVERNOR. Has been on the market but two years, and in that time has been introduced more generally than any invention ever designed for use in gas works. Over one hundred of them now in use. Sensitive; reliable; perfectly automatic; reduces leakage; satisfies consumers, and gives great relief to the Manager. No gas works is complete without one of these machines.

STEAM JET EXHAUSTER. Designed particularly for small works. Combines Exhaust Tube, Steam Governor, Gas Compensator, and Bye-Pass Valves in the most compact form possible; occupies but little space; uses very little steam; operated by ordinary workmen; saves formation of carbon in retorts; increases yield 10 to 15 per cent. Specially adapted for mixing air with oil gas. No works too small to use them profitably.

Prices given on all our specialties delivered at any point in the United States. Correspondence solicited.

CONNELLY & CO., LTD., No. 177 Broadway, New York City.

WILBRAHAM GAS EXHAUSTER

JARVIS ENGINEERING CO.,

61 Oliver St., Boston, Mass.

CONTRACTORS FOR ERECTING

COMPLETE STEAM OUTFITS FOR ELECTRIC LIGHTING STATIONS.

Steel Boilers set with Jarvis Pat. Boiler Setting

To burn **COKE SCREENINGS** for Fuel.

ARMINGTON & SIMS CO. ENGINES,

Belting direct to Dynamos, without using Shafting.

SEND FOR CIRCULARS.

REFERENCES.—Charlestown Gas & Electric Light Co., Charlestown, Mass.; Schenectady Gas & Electric Light Co., Schenectady N. Y.; Brookline Gas Co., Brookline, Mass.

Practical Electric Lighting,

By A. BROMLEY HOLMES, A.M.I.C.E.

With 87 Illustrations. Third Edition. Price, \$1.00.

Electric Light Primer.

By CHARLES L. LEVEY.

A simple and comprehensive Digest of all the most important facts connected with the running of the Dynamo and Electric Lights, with Precautions for Safety, etc.

Price, 50 cents.

A. M. CALLENDER & CO., 42 Pine St., N.Y.

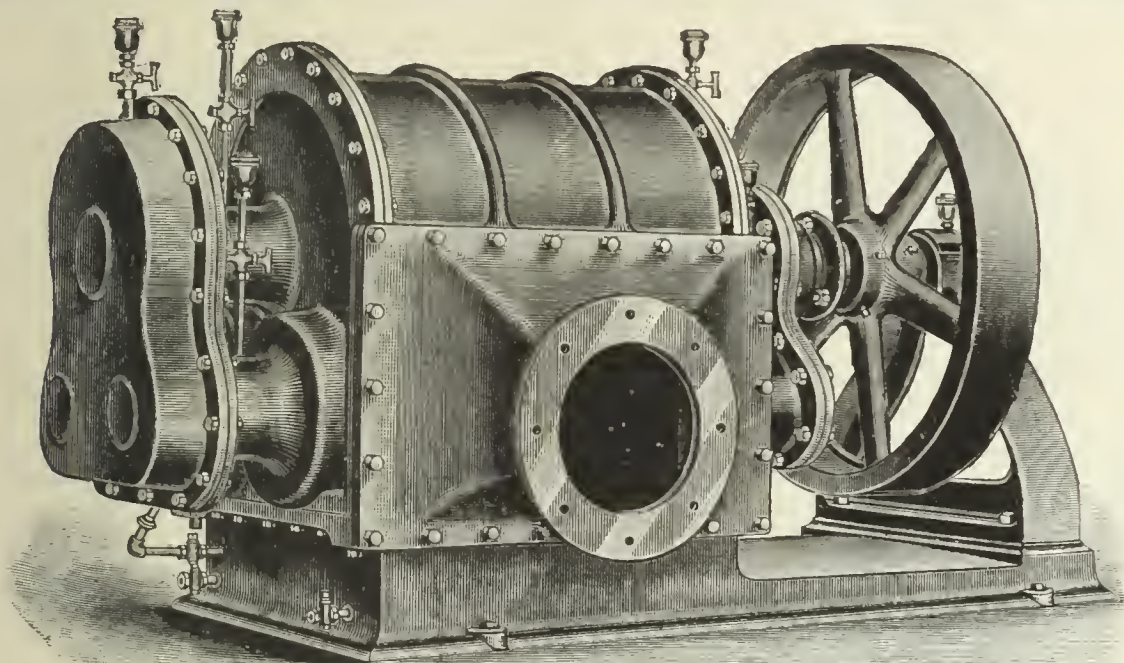

WILBRAHAM BROS.,
PHILADELPHIA, PA.

THE CLERK GAS ENGINE CO.,

Main Office, 1012, 1014, 1016, 1018 Filbert St., Philadelphia, Pa.

WM. W. GOODWIN, Prest.

E. STEIN, Sec.

S. LEWIS JONES, Asst. Sec.

A. J. DOTY, Supt.

The utility and convenience of the Gas Engine being no longer an open question, it only remains now for intending purchasers to select the BEST. We claim for the CLERK GAS ENGINE that it is equal to any other manufactured as regards steadiness in running, simplicity, and ease of keeping in repair, and that it gives the greatest amount of power for the least money (both in first cost and expense of running) of any engine made. In support of this claim we refer to the test of the Gas Engines made under the direction of the American Institute of New York, in December, 1885, and heretofore published in these columns. These engines are especially adapted for continuous running under heavy loads, and we can refer to Engines which have run 22 hours a day for months at a time

Made in Sizes of 5, 10, 15, 20, and 25 Horse Power. All Engines Guaranteed for One Year.

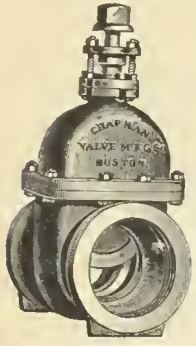

CHAPMAN VALVE MANUFACTURING CO.,

MANUFACTURERS OF

Valves and Gates for Gas, Ammonia, Water, Etc.

Also, Gate Fire Hydrants With and Without Independent Nozzle Valve. All Work Guaranteed.

WORKS & GEN'L OFFICE:
Indian Orchard, Mass.

TREASURER'S OFFICE:
72 Kilby & 112 Milk Sts, Boston, Mass.

How to Reduce Leakage to Its Minimum.

USE

HOPPER'S AUTOMATIC DIFFERENTIAL GAS GOVERNOR.

Needs No Attention. Simple, Reliable, Perfectly Automatic.
"Nearly Thirty in Use."

BYE-PASSES, DRY CENTER VALVES, PRESSURE REGISTERS. Also, GOVERNORS FOR STREET MAINS, *NOT DIFFERENTIAL*, and for EXHAUSTERS, GAS ENGINES, etc.

Our new Bye-Pass is threefold in its action—passes gas through, or bye-passes, or shuts off entirely. Correspondence solicited; information given. Send for circulars and testimonials.

T. C. HOPPER & CO., - - No. 2227 Wood Street, Philadelphia, Pa.

MILLS' REVERSIBLE LIME TRAY,

AND

WOODWORK

Of Every Description

NEEDED BY GAS WORKS.

SEND FOR CIRCULAR AND PRICE LIST TO

GEORGE A. MILLS,

Canton Av. & President St., Baltimore, Md.

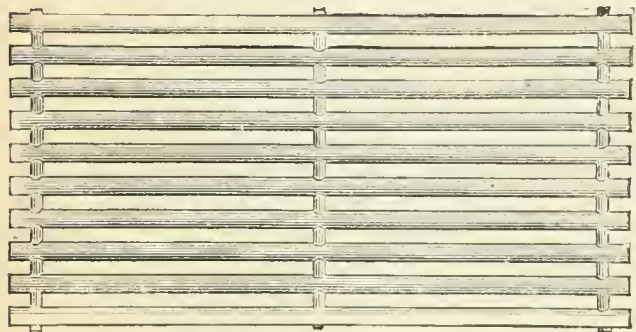

Parson's Steam Blower,

FOR IMPROVING BAD DRAUGHT IN BOILERS, AND FOR BURNING BREEZE OR OTHER WASTE MATERIAL.

PARSON'S TAR BURNER.

FOR UTILIZING COAL TAR AS FUEL.

PARSON'S AIR JET TUBE CLEANER,

FOR CLEANING BOILER TUBES.

These devices are all first-class. They will be sent to any responsible party for trial. No sale unless satisfactory. Manufactured by the WATERTOWN STEAM BLOWER COMPANY.

H. E. PARSON. Supt., 33 & 35 Liberty St., N. Y.

LUDLOW VALVE MFG. CO.

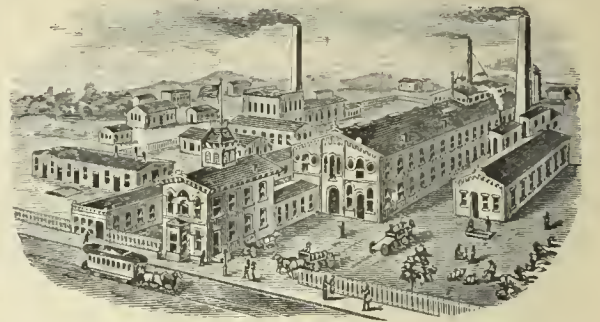

OFFICE AND WORKS,

938 to 954 River Street and 67 to 83 Vail Av
TROY, N. Y.

Hydraulic Main Dip Regulators, also
Check Valves, Foot Valves, Yard-
wash and Fire Hydrants.
Send for Circulars.

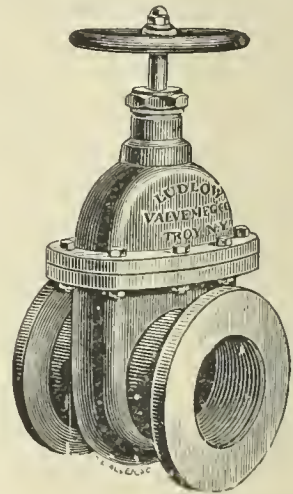

Valves.—Double and Single Gate, 1/2 in. to
48 in., outside and inside Screws. Indica-
tor, etc., for Gas, Water, Steam, and Oil.
Send for Circulars.

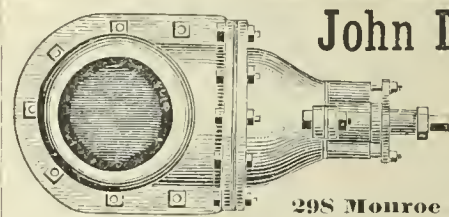

John McLean

Manufacturer of

GAS VALVES.

298 Monroe Street, N. Y.

MITCHELL VANCE & CO.,

MANUFACTURERS OF

Chandeliers

and every description of

GAS FIXTURES.

Also manufacturers of Fine Gilt Bronzes and Marble Clocks, warranted best time-keepers. Mantel Ornaments, etc.

Salesrooms, 836 Broadway, N. Y.

Special Designs furnished for Gas Fixtures for Churches, Public Halls, Lodges, etc.

KING'S TREATISE

ON THE SCIENCE AND PRACTICE OF THE

MANUFACTURE AND DISTRIBUTION OF COAL GAS.

A standard text-book for the Engineers and Managers of Gas Works, and for all who are concerned or take an interest in the manufacture and distribution of Coal Gas, and in the utilization of the Secondary Products resulting therefrom; treating also of the Gas Engine, and of Gas Cooking and Heating Appliances.

In 3 Vols. Price per Vol., \$10. Sold either by Volume or in Sets.

A. M. CALLENDER & CO.,

No. 42 Pine Street, N. Y. City.

GAS STOVES.

GAS STOVES.

GAS STOVES.

THE AMERICAN METER CO.,

MANUFACTURERS OF

GAS COOKING AND HEATING STOVES.

Gas
Heating
Stoves
in
all
Sizes
for
Parlors,
Chambers
and
Offices.

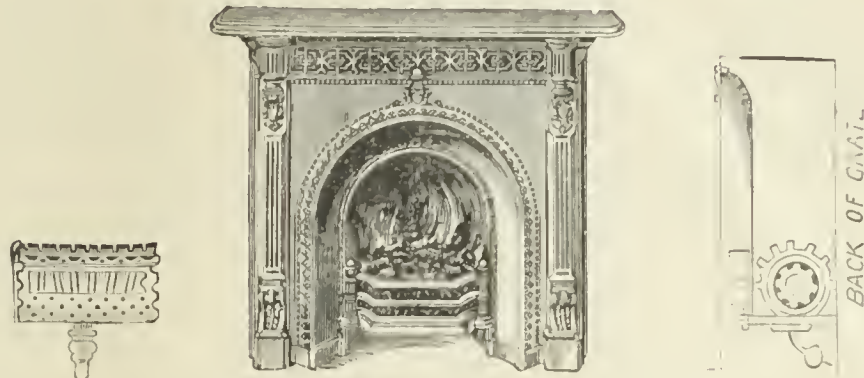

Verity's and Wilson's Patent Gas Fires For Open Fireplaces.

Gas
Cooking
Stoves
and
Ranges
in
all
Sizes
for
Family
and
Hotel
Use.

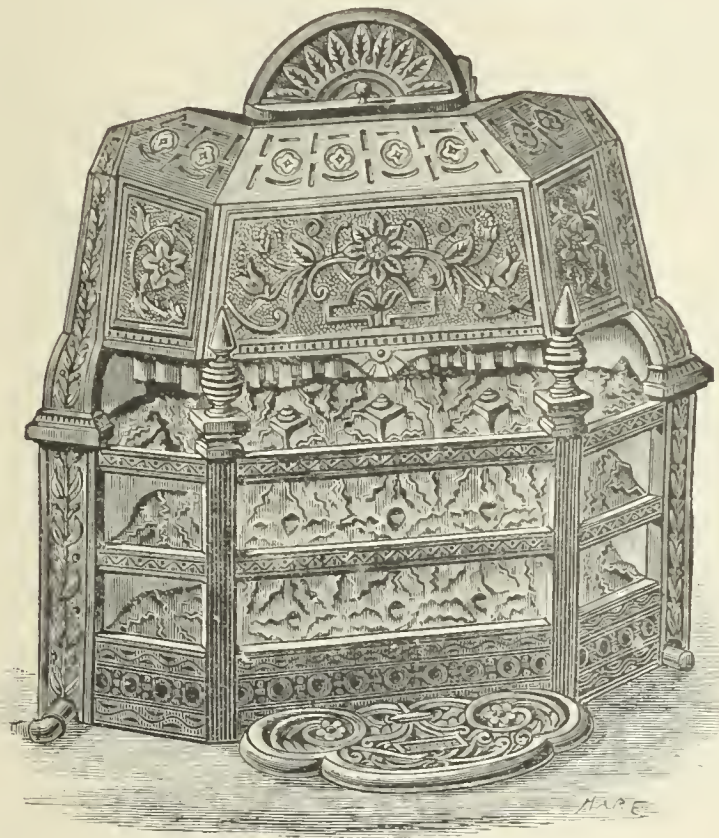

Catalogues and Price Lists on Application.

Catalogues and Price Lists on Application.

MANUFACTORIES,

508 to 514 West Twenty-second St., N. Y.

Arch and Twenty-second St., Phila

Nos. 244 & 246 North Wells Street, Chicago, Ill.

AGENCIES,

No. 177 Elm Street, Cincinnati, Ohio.

No. 222 Sutter Street, San Francisco Cal

No. 810 North Second Street, St. Louis, Mo.

GAS STOVE SHOW ROOMS, No. 223 Sixth Avenue, New York City.

RETORTS AND FIRE BRICK.

J. H. GAUTIER & CO.,
CORNER OF
GREENE AND ESSEX STREETS,
JERSEY CITY, N. J.

MANUFACTURERS OF

**Clay Gas Retorts,
Gas House Tiles,
Fire Bricks, Etc. Etc.**

Ground Clay, Fire Brick and
Fire Sand in Barrels,

J. H. GAUTIER.
C. E. GREGORY.

T. B. GAUTIER.
C. E. GAUTIER.

BROOKLYN
Clay Retort & Fire Brick Works,
(EDWARD D. WHITE & CO.)

Manufacturers of Clay Retorts, Fire Brick,
Gas House and other Tile.

VAN DYKE, ELIZABETH, RICHARDS & PARTITION STS.
Office, 88 Van Dyke St., Brooklyn, N. Y.

RETORTS AND FIRE BRICK.

LACLEDE FIRE BRICK MFG. CO.,
MANUFACTURERS OF
Fire Brick, Gas Retorts,

AND

ST. LOUIS STANDARD SEWER PIPE.

Blast Furnace and Cupola Linings, every description of Fire
Clay Material, Fire Clay Flue Linings, Chimney Tops
Dry Milled and Crude Fire Clays, etc.

OFFICE AND DEPOT

901, 903, and 905 Pine Street,
ST. LOUIS, MO.

ESTABLISHED IN 1845.

B. KREISCHER & SONS,

OFFICE FOOT OF HOUSTON ST., E. R., N. Y.

Gas Retorts,**TILES, FIRE BRICK.****AND EVERYTHING IN THE FIRE CLAY LINE.**

RETORTS AND FIRE BRICK.

MANHATTAN
FIRE BRICK & ENAMELLED CLAY
RETORT WORKS.
ADAM WEBER.

**CLAY GAS RETORTS
AND RETORT SETTINGS
FIRE BRICKS, TILES, ETC.,**

Office and Works, 15th Street and Avenue C., N. Y.



Works,
LOCKPORT STATION, PA.

—ESTABLISHED 1864.—

JAMES GARDNER, JR.,

Successor to WILLIAM GARDNER & SON.

Fire Clay Goods for Gas Works.

CHAS. H. SPRAGUE & SON, No. 70 KILBY STREET, BOSTON, MASS., Agents for the New England States.

Office, Rooms 19 & 20, Lewis Block,
PITTSBURGH, PA. P. O. Box 373.

OFFICE, 418 to 422 East 23d St., New York.

ESTABLISHED 1856.

WORKS, PERTH AMBOY, NEW JERSEY.

HENRY MAURER & SON,
Excelsior Fire Brick & Clay Retort Works
CLAY GAS RETORTS, BENCH SETTINGS, FIRE BRICK, TILES, ETC.

CHICAGO**Retort & Fire Brick Works,**

OFFICE AND FACTORY,
Clark, Forty-Fifth, and La Salle Streets,
CHICAGO, ILL.

GEORGE C. HICKS, PRES. PAUL P. AUSTIN, SEC. & TREAS.

STANDARD

Clay Retorts and Settings.**BLOCKS & TILES**

Of every Shape and Size to Order.

Standard Fire Bricks.**GEROULD'S IMPROVED RETORT CEMENT.**

A Cement for patching retorts, putting on mouthpieces, and
making up all bench-work joints. This Cement is mixed ready
for use. Economic and thorough in its work. Fully warranted
to stick. For recommendations and price list address

C. L. GEROULD & CO.,
5 & 7 Skillman St., Brooklyn, N. Y.

Western Agent, H. T. GEROULD, Mendota, Ill.

OAKHILL**GAS RETORT & FIRE BRICK**

Works.

Proprietors,

PARKER-RUSSELL MINING & MFG. CO.

City Office, 711 Pine Street,

ST. LOUIS, MO.

Our immense establishment is now employed almost entirely in
the manufacture of

MATERIALS FOR GAS COMPANIES.

We have studied and perfected three important points. Our re-
torts are made to stand changes of temperature, the strongest
heats of the furnace, and the abrasion of feeding and emptying.
Our customers are in almost every State of the Union, to all of
whom we refer

THOS. SMITH, Prest. AUGUST LAMBLA, Vice-Prest. & Sup

BALTIMORE**RETORT & FIRE BRICK CO.**

MANUFACTORY AT

LOCUST POINT, BALTIMORE, MD.

Connection with the City by Telephone.

**Clay Retorts, Blocks & Tiles,
FIRE BRICK, FIRE CLAY,
AND FIRE CEMENT.**

**Red and Buff Ornamental Tiles and Chim-
ney Tops. Drain and Sewer Pipe (from
2 to 30 inches). Baker Oven Tiles
12 x 12 x 2 and 10 x 10 x 2.**

WALDO BROS., 88 WATER ST., BOSTON, MASS
Sole Agents the New England States.

EVENS & HOWARD,

916 Market St., St. Louis. Mo.
Works, Howard Station, Mo. Pacific R.R.

Fire Brick, Gas Retorts

RETORT SETTINGS.

Sewer Pipe, 3 to 24 in. diameter.
Glass Pot Clay, Ground Fire Clay, in barrels and in bulk. All kinds of Fire Clay Goods.

Cincinnati Gas Retort & Fire Brick Works.

—ESTABLISHED 1872.—

CHAS. TAYLOR,

MANUFACTURER OF

Gas Retorts, Fire Brick, and Tile.

Blast Furnace Linings, Cupola Blocks, Boiler Tiles, Grate Settings, and Stove Linings. Fire Cement, Fire Clay, Fire Sand, and all other Fire Clay Goods.

Branch Works, New Cumberland, W. Va.

GENERAL OFFICE AND WORKS,

Burns St., Cincinnati, Ohio.

EMIL LENZ,

2 & 4 Stone St., N. Y. City.

CLAY GAS RETORTS

(ENAMELED.)

Fire Brick, Blocks & Tiles.

FIRE CEMENT, RETORT ENAMEL, RETORT CEMENT, ETC., ETC.

Regenerative and Half-Regenerative Benches.

PORTLAND CEMENT.

Correspondence Respectfully Solicited.

GAS vs. ELECTRIC LIGHT.

We would invite attention to the able and exhaustive argument of General A. Hickenlooper, President of the Cincinnati Gas Light and Coke Company, contained in a handsome pamphlet of 96 pages, entitled

"EDISON'S INCANDESCENT ELECTRIC LIGHTS FOR STREET ILLUMINATION. REPORT OF AN ARGUMENT DELIVERED BY A. HICKENLOOPER BEFORE THE COMMITTEE ON LIGHT, MUNICIPAL COUNCIL, CITY OF CINCINNATI, JULY 22, 1886."

This is a subject of special interest to all Gas Light Companies.

Prices.

25 copies.....	\$7.50	100 copies.....	\$22.50
50 copies.....	12.50	250 copies.....	50.00

A sample copy will be sent by mail on receipt of 50 cts.

A. M. CALLENDER, & CO., 42 PINE ST., N. Y. CITY.

PATENTS.

FRANKLIN H. HOUGH,

Solicitor of American & Foreign Patents

925 F. ST., WASHINGTON, D. C.

(NEAR U. S. PATENT OFFICE.)

Personal attention given to the preparation and prosecution of applications for Letters Patent. All business before the U. S. Patent Office attended to for moderate fees. **No Agency in the United States possesses superior facilities for obtaining Patents,** or for ascertaining the patentability of inventions. Copies of patents furnished for 25 cents each. Correspondence solicited.

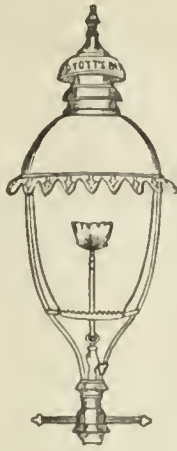

STEPHEN A. MORSE, President.
GODFREY REBMANN, Vice-Pres.

M. B. DYOTT,
Superintendent.

EDWIN F. MORSE, Secretary.
CARLTON M. WILLIAMS, Treas.

STANDARD GAS LAMP CO.,

Office, 411 Cherry St. Factory, 1101, 1103 & 1105 Frankford Av.

Philadelphia, Pa.

It is to the interest of Gas Companies and Cities to use Dyott's Patent Champion Lamps, which give double the light with the same consumption of gas, and will save 50 per cent. over others in cost of keeping in repair. Gas Companies and others intending to erect Lamps of any description will do well to communicate with us. Special Drawings furnished and Estimates given on application upon Architects', Engineers' or our Draughtsmen's Plans.

Our Patent System of Instantaneously Lighting Gas (without electricity) for R. R. Depots is unequalled. Our High Candle Power Burner is superior to the Electric Light or any other High Candle Burner. We manufacture every description of Ornamental Lamps.

KLOENNE & BREDEL

IMPROVED REGENERATIVE FURNACES.

Self-Sealing Mouthpieces & Bridge-Pipes, Retort Houses.

WASHER-SCRUBBERS

Gas holders, and Complete Gas Works.

Refers, by permission, to Mr. Eugene Vanderpool, of Newark, N. J.; Mr. E. G. Cowdery, of Milwaukee, Wis.; and Mr. Theo. Forstall, of Chicago, Ill. For further information apply to

FRED. BREDEL, 332 East 17th St., N. Y. City.

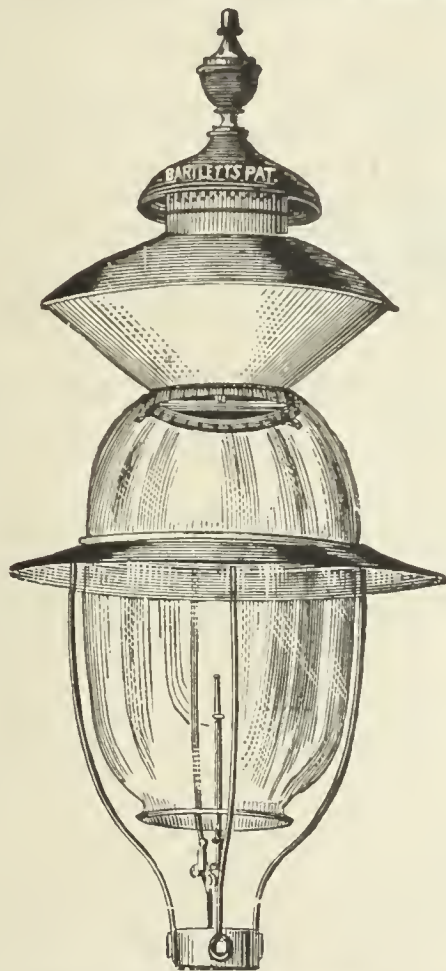

G. S. COOK, Pres. THOS. DAVENPORT (late Davenport Bros.), Sec. & Treas.

BARTLETT

Street Lamp Mfg. Co.

MANUFACTURERS OF

Bartlett's Patent

GLOBE LAMPS.

FOR

Streets, Parks, Railroad Stations, Public Buildings, Etc.

LAMP POSTS A SPECIALTY.

Office and Salesroom

40 & 42 College Place, N. Y. City.

Gas Companies and others intending to erect lamps and posts will do well to communicate with us.

Ferric Oxide for Gas Purification.

Ferric Oxide, as ground, screened, and prepared by me for purifying purposes, has now been in use for several years by many of the gas works throughout the country, including Detroit, Chicago, Milwaukee, East Saginaw, Burlington (Iowa), Ann Arbor, etc. It has proved, as I believe, the **Most Effective and Economical Agent** now in use. I am prepared to furnish the Oxide by the 100 lbs. or in car load lots, and will be pleased to give price f.o.b. cars at Ann Arbor or at place of destination. Address

S. H. DOUGLAS, Prest. Ann Arbor (Mich.) Gas Light Co.

GAS AND WATER PIPES.

GAS AND WATER PIPES.

ENGINEERS.

SAM'L R. SHIPLEY, Pres.
HENRY B. CHEW, Treas.

JAS. P. MICHELLON, Sec.
WM. SEXTON, Supt.

P. D. WANNER, Chairman. A. H. MELLERT, Sec. & Treas.

GLOUCESTER IRON WORKS,
GLOUCESTER CITY, N. J.



Cast Iron Gas & Water Pipes, Stop Valves, Fire Hydrants, Gasholders. &c.

Office No. 6 North Seventh Street, Philadelphia.

MELLERT FOUNDRY & MACHINE CO., Ltd.

Reading, Pa.



Specials—Flange Pipe, Valves and Hydrants, Lamp Posts, Retorts, etc.

General Foundry and Machine Work.

JOHN FOX, Selling Agent. 160 Broadway, N. Y.

THE OHIO PIPE COMPANY,

MANUFACTURERS OF

Cast Iron Gas & Water Pipe,

BRANCH AND SPECIAL CASTINGS.

Gas-House Bench Castings, Hydraulics, Lamp Posts, Flange Pipe and Specials, Architectural Castings, Building Columns, Joists, Cellar Grates, Sash Weights, etc.

GENERAL FOUNDERS AND MACHINISTS.

Columbus, Ohio.

M. J. DRUMMOND,



SPECIAL CASTINGS AND LAMP POSTS.
Equitable Building, 120 Broadway, N. Y.

JOS. R. THOMAS, C.E.,

May be Consulted on all Matters Relating to Gas Works and Gas Manufacture.

ADDRESS THIS OFFICE.

WM. MOONEY

(Successor to WM. FARMER)

27 Pearl Street, N. Y. City.

(One door from Whitehall Street.)

CONTRACTOR FOR THE ERECTION OF GAS WORKS, OR APPARATUS OF ANY CAPACITY. AGENT FOR WM. FARMER'S PATENTS.

Plans and Specifications Furnished.

WM. HENRY WHITE,

CONSULTING AND CONSTRUCTING

Gas Engineer & Contractor

Estimates, Plans, and Specifications furnished for new works or extensions of existing works.

No. 32 Pine Street, New York City.

Correspondence solicited.

WM. GARDNER,
Gas Engineer,

Lewis Block, Room 20, Pittsburgh, Pa.

Those who intend to make alterations in existing gas plants, or who contemplate the erection of new works, will find it to their interest to open correspondence with the above. Plans made and estimates furnished.

MATTHEW ADDY, President.

W. L. DAVIS, Selling Agent.

GEO. P. WILSHIRE, Sec. & Treas.

Cincinnati and Newport Iron and Pipe Company,

NEWPORT, KY.

Lamp Posts
AND
BENCH CASTINGS

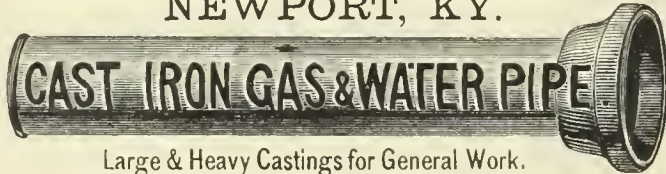

Branch
AND
SPECIAL CASTINGS

A Specialty.

Large & Heavy Castings for General Work.

FOR GAS & WATER CO'S.

Manufacture Pipe from 2 to 48 inches. All work guaranteed first quality.

Pancoast & Rogers.

WROUGHT IRON PIPE,

VALVES AND GATES,

Cast Iron Gas & Water Pipe.

28 Platt and 15 Gold St., New York.

Water & Gas Pipe.

RUSTLESS

Send for New Catalogue.

RUSTLESS

The WELLS RUSTLESS IRON COMPANY,

Nos. 7 and 9 Cliff Street, New York City.

The Management of Small Gas Works.

By C. J. R. HUMPHREYS. Price, \$1.

A running commentary on the different sections of gas management with reference to small undertakings, with some notes on the erection of the necessary plant.

A. M. CALLENDER & CO., 42 Pine St., N. Y.

GAS LAMPS.

SCRUBBERS AND CONDENSERS.

The Siemens and Lungren REGENERATIVE GAS LAMPS.

A System of Burning Gas whereby its Illuminating Power is Increased from 300 to 400 per ct. without the Expense, Trouble and Annoyance resulting from the use of Hydrocarbon Enriching Material.

The Siemens-Lungren Company received the only Silver Medal or Highest Award for Gas Burners at the "Novelties" Exhibition of the Franklin Institute, held at Phila., Oct., '85.

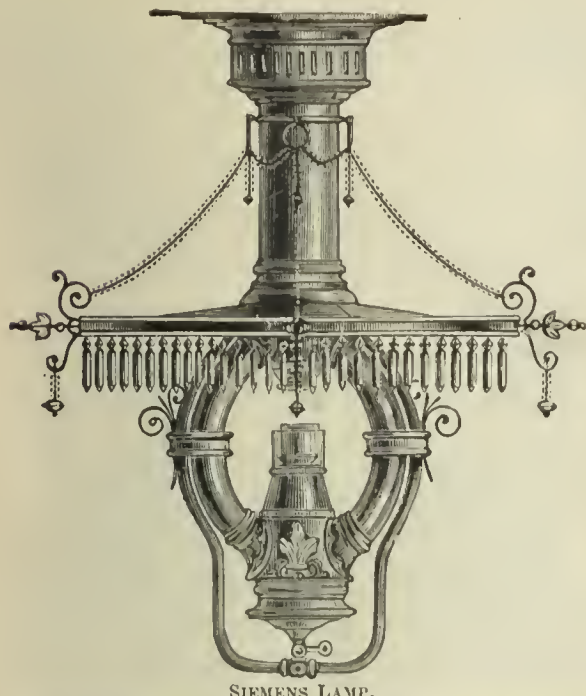

SIEMENS LAMP.

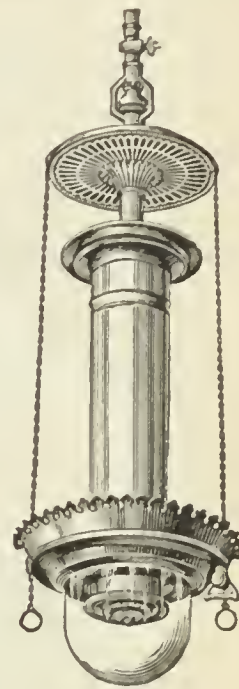

LUNGREN LAMP

THIRTEEN CANDLE POWER PER CUBIC FOOT OF GAS!

This result is obtained

SIMPLY BY THE SCIENTIFIC APPLICATION OF THE REGENERATIVE PRINCIPLE.

Consequently this largely increased illumination is always maintained without further cost and frequent attention.

THE SIEMENS-LUNCREN COMPANY,

N. E. Cor. 21st. St. and Washington Av., Phila.. Pa.

KIRKHAM, HULETT & CHANDLER, Limited,

London, S. W., England.

PATENT "STANDARD" WASHER-SCRUBBERS.

Following are extracts from letters received from some of the Gas Light Companies now using the "Standard" Washer-Scrubber:

SAN FRANCISCO, Sept. 21, 1887.

GEO. SHEPARD PAGE, ESQ.:

Dear Sir—In reply to yours, would say that the ammonia is entirely removed from the gas by the use of the "Standard" Washer-Scrubber.

Yours truly, J. B. CROCKETT, Prest.,
San Francisco Gas Lt. Co.

BOSTON, MASS., Aug. 30, 1887.

GEO. SHEPARD PAGE, ESQ.:

Dear Sir—The "Standard" Washer-Scrubber at these works is giving good satisfaction, and the increased amount of ammonia eliminated from the gas by its use enables us to obtain a larger income from the ammoniacal liquor.

Truly yours, THOS. J. PISHON, Supt.,
Roxbury Gas Lt. Co.

GEORGETOWN, D. C., Sept. 27, 1887.

GEORGE SHEPARD PAGE, ESQ.:

Dear Sir—The "Standard" Washer-Scrubber, together with all the work of connecting the same with these works, has given entire satisfaction.

Truly yours, J. B. CATHELL, Supt.,
Georgetown Gas Lt. Co.

BROOKLYN, N. Y., Sept. 8, 1887.

GEORGE SHEPARD PAGE, ESQ.:

Dear Sir—By the use of the "Standard" Washer-Scrubber at these works the ammonia is entirely removed from the gas, and our income from the ammoniacal liquor has been increased 100 per cent.

Yours truly,
C. W. BLODGET, Sec.,
Williamsburgh Gas Lt. Co.

GEO. SHEPARD PAGE, 69 WALL STREET, NEW YORK,

Agent for the Western Hemisphere.

GAS WORKS APPARATUS AND CONSTRUCTION.

GAS WORKS APPARATUS AND CONSTRUCTION.

WORKS: { MILLVILLE, N. J.
FLORENCE, "
CAMDEN, "

R. D. WOOD & CO.,

OFFICES: { 400 CHESTNUT ST.,
PHILADELPHIA.

GAST-IRON PIPE 1½ to 72 Inches in Diameter.

Water Machinery and Gas Apparatus.

HEAVY CASTINGS.

HOLDERS,

PURIFIERS,

FLOORS AND ROOFS,

LAMP POSTS,

CONDENSERS,

FLANGED PIPE,

VALVES,

BENCH WORK,

FIRE HYDRANTS,

METER CASES.

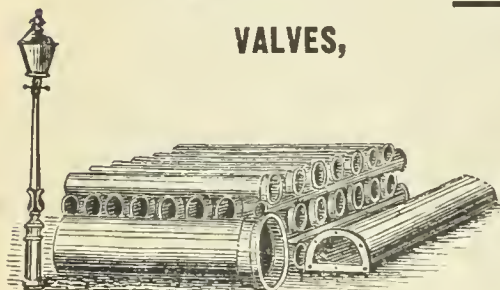

Estimates and Specifications for
NEW WORKS or **EXTENSIONS**
or **ALTERATIONS** of **OLD ONES.**

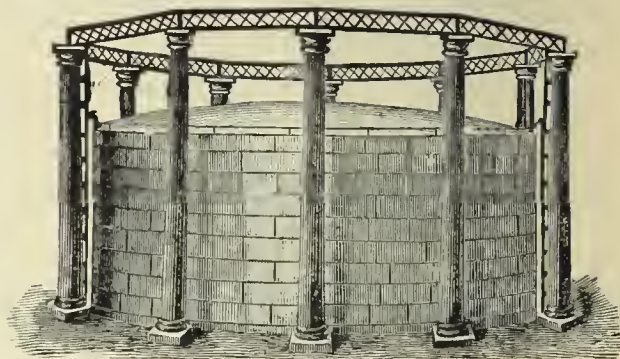

GASHOLDER TANK CONSTRUCTION, ETC.

Gas Companies and others about to erect Gasholders will find it profitable to consult W. C. WHYTE, who for over thirty years has made a specialty of

Holder Tank Excavation and Mason Work.

Fifty tanks now in operation show the sort of work done. Address

W. C. WHYTE, No. 15 Cortlandt St., N. Y. City.

MORRIS, TASKER & CO.,

Limited,

Builders of Gas Works,

PHILADELPHIA PA.

GASHOLDERS, PURIFIERS, SCRUBBERS, CONDENSERS, EXHAUSTERS,

Bench Castings, Iron Roofs, Lamp Posts

VALVES, STREET MAIN SPECIALS, ETC.,

MANUFACTURED BY

KERR MURRAY MANUFACTURING COMPANY

From 1880 to 1886, inclusive, we erected Gasholders for the following cities, viz.:

Adrian, Mich.	East End Gas Co., Pitts-	Janesville, Wis.	New Castle, Pa.	Valparaiso, Ind.
Akron, Ohio.	burgh, Pa.	Johnstown, Pa.	Niagara Falls, N. Y.	Van Wert, Ohio.
Albuquerque, N. M.	East Saginaw, Mich.	Key West, Fla.	Osawatomie, Kans.	Wabash, Ind.
Altoona, Pa.	Elgin, Ills.	La Crosse, Wis.	Pittsburgh, Pa. (2)	Waco, Texas.
Anderson, Ind.	Evanston, Ills.	Lebanon, Ind.	Plainfield, Ind.	Waukesha, Wis.
Bellaire, Ohio.	Eufaula, Ala.	Lima, Ohio.	Portage City, Wis.	Wheeling, West Va.
Birmingham, Ala.	Frankfort, Ind.	Logan, Ohio.	Sedalia, Mo.	Wellington, Kans.
Bucyrus, Ohio.	Freeport, Ills.	Louisville, Ky.	Sheboygan, Wis.	West Pittsburgh, Pa.
Canton, Ohio.	Galesburg, Ills.	Mankato, Minn.	South Bend, Ind.	Xenia, Ohio.
Circleville, Ohio.	Grafton, West Va.	Mansfield, Ohio.	South Chicago, Ills.	Youngstown, Ohio.
Colorado Springs, Col.	Greensburg, Pa.	Marshalltown, Iowa.	Springfield, Ills.	Ypsilanti, Mich.
Danbury, Conn.	Huntington, Ind. (2)	Meridian, Miss.	Streator, Ills.	
Delaware, Ohio.	Ironton, Ohio.	Minneapolis, Minn.	Topeka, Kans.	
Delphos, Ohio.	Jamestown, N. Y.	Muskegon, Mich.	Uniontown, Pa.	

Under construction, 1887.

Arkansas City, Kans.	Grand Forks, Dakota.	Mobile, Ala.	Santa Fe, N. M.	Fuel Gas and Electric Engi-
Dallas, Texas.	Grand Rapids, Mich.	Pittsburgh, Pa.	Wichita, Kans.	neering Co., Pittsburgh, Pa.
El Paso, Texas.	La Crosse, Wis.	Pine Bluff, Ark.	Lexington, Mo.	Stillwater, Minn.

Estimates, with Plans and Specifications, for new or the rebuilding of old works, furnished on application. Correspondence solicited. Address

KERR MURRAY MANUFACTURING CO.,

A. D. CRESSLER, General Manager.

FORT WAYNE IND.

GAS WORKS APPARATUS AND CONSTRUCTION.

GAS WORKS APPARATUS AND CONSTRUCTION.

JAMES R. FLOYD,

(SUCCESSOR TO HERRING & FLOYD)

Oregon Iron Works,

531 to 543 West 20th St., N. Y.

Practical Builders of Gas Works,

MANUFACTURERS OF

ALL KINDS OF CASTINGS

AND

APPARATUS FOR GAS-WORKS.

BENCH CASTINGS

from benches of one to six Retorts each.

WASHERS: MULTITUBULAR AND AIR CONDENSERS; CONDENSERS; SCRUBBERS

(wet and dry), and

EXHAUSTERS

for relieving Retorts from pressure.

BENDS and BRANCHES

all sizes and description.

FLOYD'S PATENT

MALLEABLE RETORT LID.

PATENT

SELF-SEALING RETORT LIDS.

FARMER'S

PATENT BYE-PASS DIP-PIPE.

SABBATON'S PATENT

FURNACE DOOR AND FRAME.

BUTLER'S

COKE SCREENING SHOVELS.

GAS GOVERNORS,

and everything connected with well regulated Gas Works at low price, and in complete order.

SELLER'S CEMENT

for stopping leaks in Retorts.

N. B.—**STOP VALVES** from three to thirty inches at very low prices.

Plans, Specifications, and Estimates furnished.

THE CONTINENTAL IRON WORKS.

THOS. F. ROWLAND, Prest.

WARREN E. HILL and CHAS. H. CORBETT, V.-Pres.

THOS. F. ROWLAND, JR., Sec. & Treas.

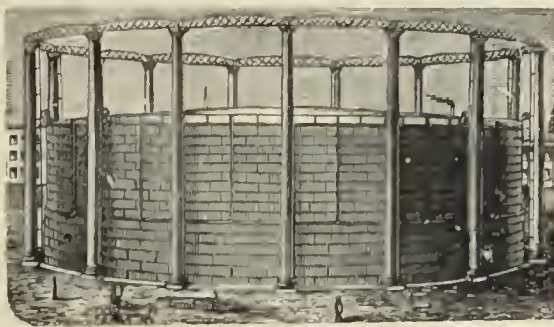

GAS HOLDERS OF ANY MAGNITUDE.

P. O. Station G., BROOKLYN, N. Y.

ENGINEERS AND MANUFACTURERS OF

Gas Holders

CONDENSERS, SCRUBBERS, VALVES,

PURIFIERS, SELF-SEALING RETORT LIDS,

Hydraulic Mains,

And all other articles connected with the manufacture and distribution of Gas.

H. RANSHAW, Prest. & Mangr.

WM. STACEY, Vice-Prest.

T. H. BIRCH, Asst. Mangr.

R. J. TARVIN, Sec. & Treas.

STACEY MFG. CO.,

MANUFACTURERS OF

Single and Telescopic Gasholders,

IRON ROOFS, BRIDGES, LAMP POSTS,

Water and Oil Tanks, Coal Elevator Cars,

COKE CRUSHERS, BENCH CASTINGS,

And all kinds of Wrought and Cast Iron Work used in the erection of Coal and Oil Gas Works. Rolling Mill Machinery and Heavy Castings a Specialty.

Foundry:

33, 35, 37 & 39 Mill Street.

Wrought Iron Works:

16, 18, 20, 22, 24 & 26 Ramsey Street.

Cincinnati, Ohio.

Bouton Foundry Co.,

FOUNDERS AND MACHINISTS,

CHICAGO, ILL.

Gas Works Apparatus,

PURIFIERS, CONDENSERS,

Bench Work,

SPECIALS, LAMP POSTS,

SCRUBBERS,

Iron Roofs and Floors.

Plans and Estimates furnished for new works or extensions of old works.

1842. **DEILY & FOWLER,** 1887.

Laurel Iron Works.

Address, No. 39 Laurel Street, Philadelphia, Pa.

MANUFACTURERS OF

GASHOLDERS,

Single and Telescopic.

Holder Built 1882 to 1886, Inclusive:

- | | | | | |
|---------------------------|---------------------------|----------------------------|----------------------------|---------------------------|
| Denver, Col. | Warren, Ohio. | Allegheny, Pa. (21.) | York, Pa. | Salem, N. J. (3d) |
| Chicago, Ill. (West Side) | Bath, N. Y. | Atlanta, Ga. (2d.) | Chester, Pa. | Omaha, Neb. (2d) |
| Pittsburgh, Pa. (S. Side) | Lynn, Mass. | N.Y. City (Central Gas Co) | Hazleton, Pa. (2d.) | Lynn, Mass. (2d) |
| Pawtucket, R. I. | New Bedford, Mass. | Lynchburg, Va. (2d.) | State Island, N. Y. | Little Rock, Ark. |
| Brookline, Mass. | Waterbury, Conn. | Saylesville, R. I. | Saugerties, N. Y. | Irrington, N. Y. |
| Sherbrooke, Can. | Deseronto, Can. | Rondout, N. Y. | Clinton, Mass. (Lan Mills) | South Boston, Mass. |
| Burlington, N. J. (2d) | Hoosic Falls, N. Y. (2d.) | Atlantic City, N. J. | Chattanooga, Tenn. | Rye, N. Y. (2) |
| Bridgeton, N. J. | Bethlehem, Pa. | Augusta, Ga. | Galveston, Texas. (3d.) | Woodstock, Ont. |
| Bay City, Mich. | Atlanta, Ga. (1st.) | Waltham, Mass. (2) | Omaha, Neb. | Malden, Mass. |
| Erie, Pa. | Savannah, Ga. | Mahanoy City, Pa. | Fort Plain, N. Y. | Staten Island, N. Y. (2d) |
| Jackson, Mich. | Montgomery, Ala. | New Castle, Pa. | Brunswick, Ga. | |
| Kalamazoo, Mich. (3d.) | Newport, R. I. | Long Island City, N. Y. | Port Chester, N. Y. | |
| Glen Island, N. Y. | Portland, Oregon. | Macón, Ga. | New Rochelle, N. Y. | |

SMITH & SAYRE MFG. COMPANY,

G. PORTER, Prest.

245 Broadway, N. Y.

CHAS. W. ISBELL, Sec'y.

Machinery & Apparatus for Gas Works

Drawings, Plans, and Estimates Furnished for the Improvement, Extension, or Alteration of Gas Works, or for the Construction of New Works.

Mackenzie's Patent Rotary and Steam Jet Gas Exhausters, Governors, Compensators, Condensers, Washers, Scrubbers. Isbell's Patent Automatic Street Pressure Governor Gas and Water Valves, Hydraulic Main Dip Regulator, Bench Castings, etc. Purifying Boxes and "Standard" Scrubbers. Isbell's Patent Self-Sealing Retort Doors.

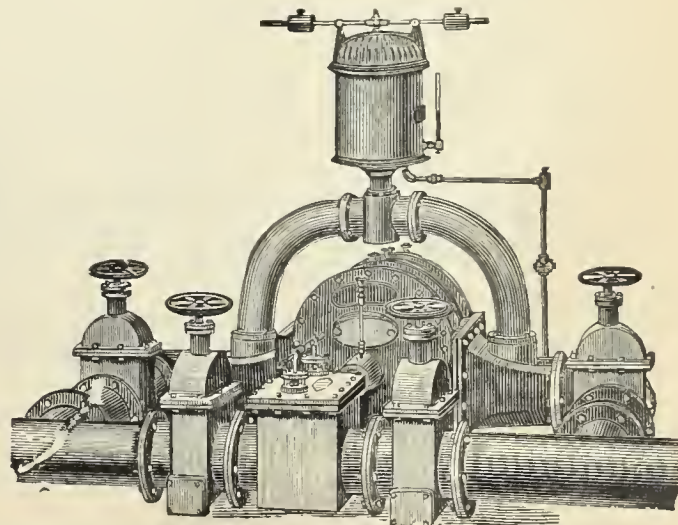

GAS COALS.

CANNEL COALS.

GAS ENRICHERS.

JAMES D. PERKINS.

PERKINS & CO.,

F. SEAVERN.

General Sales Agents for

The Youghioghenny River Coal Company's**OCEAN MINE YOUGHIOGHENY GAS COAL.**

The Coal from the Ocean Mine (recently operated by *Messrs. W. L. Scott & Co.*, of Erie, Pa.,) is now used by all the leading Gas Companies in the United States from Maine to Texas, and is recognized as *the only reliable Youghioghenny Gas Coal.* (See Map on p. 87 of this Journal, Feb. 16, '85.)

P. O. Box 3695,
New York.**PERKINS & CO., 228 and 229 N. Y. Produce Exchange.**BEAVER STREET
ENTRANCE.**BRECKENRIDGE CANNEL,
OF KENTUCKY.**

This Colliery was re-opened in June, 1886, since which date the Cannel has been delivered to over sixty of the leading Gas Companies in this country and in Europe. As an enricher ONE TON of this Cannel will do the work of two TONS of any other available Cannel, and is more economical than Naptha or Oil of any character. It can be delivered in parcels of one car load or more to any point in the United States or Canada.

(See AMERICAN GAS LIGHT JOURNAL, June 16, '86, pp. 346-7.)

P. O. Box 3695,
New York.**PERKINS & CO., 228 and 229 N. Y. Produce Exchange**BEAVER STREET
ENTRANCE.**JAMES & WILLIAM WOOD,****Gas and Cannel Coal Contractors,**

No. 40 St. Enoch Sq., Glasgow. No. 2 Talbot Court, London.

Proprietors of the **BATHVILLE COLLIERIES** (which produce the celebrated **BOGHEAD CANNEL**), Shields, Shieldmuir, Drumpeller, and other Collieries. This Firm offer

STANDARD CANNELS,**Unequaled as Gas Enrichers.**

Analyses, prices, and all further information furnished on application to

Agency for U. S., Room 93, Nos. 2 & 4 Stone St., N. Y. City.**The Standard Oil Company,**

REFINERS OF

NAPTHA AND GASOLINES.

ALSO MANUFACTURERS OF

**A Special Grade of Naptha for
Gas Companies****FOR ENRICHING COAL GAS.**

Correspondence solicited.

No. 43 Euclid Avenue, Cleveland, Ohio.

To Gas Companies.We make to order **CAP BURNERS** to burn any amo
under a stated pressure. Send for samples.Also, **SERVICE CLEANERS, DRIP PUMPS, and STRE
MAIN PROVING APPARATUS.****C. A. GEFROER,**

248 N. 5th Street, Phila., Pa.

GOODWIN'S DIRECTORY**OF THE GAS LIGHT COMPANIES of the UNITED STATES & CANADA.****Price, \$3.00.**

Orders may be sent to

A. M. CALLENDER & CO., No. 42 Pine Street, N. Y. City.

COKE CRUSHERS.

Newburgh Orrel Coal and Coke Co.

MINERS AND SHIPPERS OF

Mountain Brook Steam and Smithing Coals,

**NEWBURGH, PALATINE,
AURORA & TYRCONNELL
GAS COALS.**

Foundry & Crushed Coke Shipped Direct from Ovens

Mines Situated at

Newburgh, Flemington & Fairmont, W.Va.

HOME OFFICE,

33 S. Gay St., Baltimore.

CHAS. MACKALL, Gen. Mangr.

CHAS. W. HAYS, Agent in New York,

Room 117, WASHINGTON BUILDING, No. 1 Broadway.

Shipping wharves at Locust Point, Baltimore.

THE DESPARD COAL COMPANY

OFFER THEIR SUPERIOR

DESPARD COAL

To Gas Light Companies and Manufacturers of Fire Clay Goods
Throughout the Country.

ROUSSEL & HICKS,) AGENTS. (BANGS & HORTON,
71 Broadway, N. Y.) (16 Kilby St., Boston.

Mines in Harrison Co., West Va. Wharves, Locust Point, Balt.

Company's Office, 15 German St., Baltimore, Md.

Among the consumers of Despard Coal we name: Manhattan
Gas Light Co., N. Y.; Metropolitan Gas Light Co., N. Y.; Jersey
City, (N. J.) Gas Light Co.; Washington (D. C.) Gas Light Co.;
Portland (Maine) Gas Light Co. Reference to them is requested.

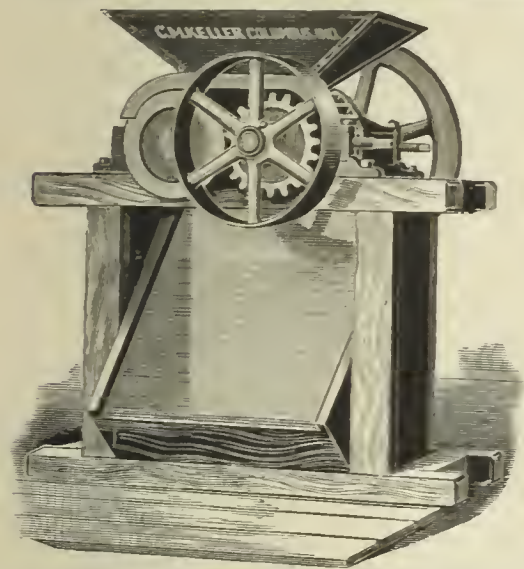

Keller's Adjustable Coke Crusher.

SIMPLE, STRONG, AND DURABLE.

C. M. Keller, Sec. & Supt. Gas Lt. & Coke Co. Columbus, Ind.

Correspondence Solicited.

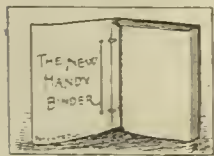

**THE NEW
HANDY BINDER.**

This article may be described as elegant
in appearance, strong, durable, and possessing many special
qualities of its own. It allows the opening of the pages per-
fectly flat, whether one or several numbers are in the binder.
Any number can be taken out and replaced without disturbing
the others. The papers are not mutilated for subsequent bind-
ing in permanent form. The binder is supplied with gilt side
title, and is an ornament to any desk or reading table. The
JOURNAL, filed in the Handy Binder, becomes a volume of great
value, always convenient for instant reference. Handy Binder,
Postage paid, \$1.00.
A. M. CALLENDER & CO., 42 Pine St., N. Y.

GAS COALS.

GAS COALS.

THE
PENN GAS COAL CO.

OFFER THEIR

Coal, Carefully Screened & Prepared for Gas Purposes

Their Property is located in the Youghiogheny Coal Basin, near Irwin and Penn Stations on the
Pennsylvania Railroad, and on the Youghiogheny River.

Principal Office:

209 SOUTH THIRD STREET, PHILA., PA.

Points of Shipment:

Pennsylvania Railroad Piers; Greenwich Wharves, Delaware
River; Pier No. 1 (Lower Side), South Amboy, N. J.

Chesapeake & Ohio Railway Coal Agency,

FOR THE SALE OF THE

**Superior Kanawha Gas Coals, Cannelton Cannel,
Also, SPLINT AND STEAM COALS,**

From the Kanawha and New River Regions, on the line of the Chesapeake & Ohio R'way.

C. B. ORCUTT, Sales Agent. | OFFICE, 150 BROADWAY, N. Y.

FRANCIS H. JACKSON, Presl. EDMUND H. MCCULLOUGH, V.-Presl. CHAS. F. GODSHALL, Treas. H. C. ADAMS,

THE WESTMORELAND COAL CO.

Chartered 1854.

Mines situated on the Pennsylvania and the Baltimore
and Ohio Railroads, in Westmoreland County, Penn.

POINTS OF SHIPMENT:

PHILADELPHIA, BALTIMORE, SOUTH AMBOY, N. J.,
WATKINS (SENECA LAKE), N. Y.

Since the commencement of operations by this Company its well-known
Coal has been largely used by the Gas Companies of New England and the
Middle States, and its character is established as having no superior in gas
giving qualities, and in freedom from sulphur and other impurities.

Principal Office, 224 South 3d St., Phila., Pa.

A. M. SCOTT, PRESIDENT.

A. DEMPSTER, C.E., SECRETARY.

W. K. GILLESPIE, TREASURER.

MONONGAHELA AND PETERS CREEK GAS COAL CO.,

PRODUCERS OF

Coal Bluff Gas Coal.

MINES LOCATED ON THE MONONGAHELA DIVISION OF THE PENNSYLVANIA RR.,
IN THE CENTRAL PORTION OF THE PITTSBURGH COAL FIELD.

Points of Shipment—Buffalo, Cleveland, Erie, Chicago, New Orleans.

Since the introduction of Coal Bluff Gas Coal it has taken rank among the few first-class Gas Coals, and ac-
knowledges no superior in gas-giving qualities, ease of working, quality of coke, and freedom from impurities.

General Office, 43 Sixth Ave., Pittsburgh, Pa.

GAS METERS.

GAS METERS.

GAS METERS.



INTERNATIONAL--1876--EXHIBITION.

The U. S. Centennial Commission

HAVE DECREED AN AWARD TO

HARRIS, GRIFFIN & CO.,

Twelfth and Brown Streets, Philadelphia, Pa. No. 49 Dey Street, N. Y. City, and No. 75 North Clinton Street, Chicago, Ill.

FOR THE FOLLOWING REASONS :

The Exhibit consists of a Series of METERS from the Largest Size Station Meters for the use of the MANUFACTURE OF GAS, to those for the use of the ORDINARY CONSUMER. The Instruments are WELL MADE, RELIABLE as to INDICATION, and embody a number of sundry improvements which, with the general character of the Exhibit, entitle the whole to commendation.

Attest—J. L. CAMPBELL,
Secretary, pro-tem

Signed—A. T. GOSHORN,
Director General

J. R. HAWLEY,
President



Dry Gas Meter.

With 39 years' experience and the best facilities for manufacturing, is enabled to furnish reliable work and answer orders promptly.

NATHANIEL TUFTS,

No. 153 Franklin Street, Boston, Mass.,

MANUFACTURER OF

DRY GAS METERS.

Station Meters of any Capacity.

Test and Experimental Meters, Pressure Registers, Pressure Gauges, Pressure and Vacuum Gauges.

METER PROVERS, PHOTOMETERS, STREET LANTERNS, ETC., ETC.

Patent Cluster Lanterns for Street Illumination.

CHARLES E. DICKEY.

JAMES B. SMALLWOOD.

CHARLES H. DICKEY.

Maryland Meter and Manufacturing Co.,307 and 309 Saratoga Street, Baltimore, Md. 195 and 197 Michigan Street, Chicago, Ill.
1115 Olive Street, St. Louis, Mo.

MANUFACTURERS OF

DRY GAS METERS, STATION METERS, GLAZED METERS, TEST METERS, METER PROVERS, PRESSURE & VACUUM REGISTERS,

Governors, Indicators, Service and Meter Cocks, and Meter Connections.

"SUCCESS" GAS RANGES.

Meter Repairing a Specialty.

SCIENTIFIC BOOKS.

We are prepared to furnish to Gas Managers, and others interested in the topics treated of, the following books, at prices named :

KING'S TREATISE ON THE MANUFACTURE OF COAL GAS. Three vols.; \$10 per vol.	PRACTICAL TREATISE ON HEAT, by THOMAS BOX. Second edition. \$5.	THE GAS MANAGER IN THE LABORATORY, by a Practical Student. 8vo., Cloth. \$1.50.
GAS MANUFACTURE, by WILLIAM RICHARDS. 4to., with numerous Engravings and Plates, in Cloth binding. \$12.	GAS WORKS—THEIR ARRANGEMENT, CONSTRUCTION, PLANT, AND MACHINERY. \$8.	THE DOMESTIC USES OF COAL GAS, AS APPLIED TO LIGHTING, by W. SUGG. \$1.40.
THE GAS ANALYST'S MANUAL, by F. W. HARTLEY. \$2.50.	COAL; ITS HISTORY AND USE. by PROF. THORPE. \$3.50.	DISTILLATION OF COAL TAR AND AMMONIACAL LIQUOR by GEO. LUNGE. New Edition. \$12.50.
TECHNICAL GAS ANALYSIS. \$2.80.	THE GAS WORKS OF LONDON, by COLBURN. 60 cents.	A TREATISE ON THE COMPARATIVE COMMERCIAL VALUES OF GAS COALS AND CANNELS, by D.-A. GRAHAM 8vo., Cloth. \$3.
GAS MANAGER'S HANDBOOK, by THOS. NEWBIGGING. \$4.80.	THE GAS FITTER'S GUIDE, Showing the Principles and Practice of Lighting with Coal Gas, by JOHN ELDREDGE. 40 cents.	GAS AS A SOURCE OF LIGHT, HEAT, AND POWER, by C. J. R. HUMPHREYS. 10 cents.
GAS CONSUMER'S GUIDE. \$1.	GAS WORKS, AND MANUFACTURING COAL GAS, HUGHES. \$2.20.	GAS COMPANIES DIRECTORY. \$3.
A GUIDE TO GAS LIGHTING. 40 cents.	THE MANAGEMENT OF SMALL GAS WORKS, by C. J. R. HUMPHREYS. \$1.	GAS VERSUS ELECTRIC LIGHT. 50 cents.
GAS MEASUREMENT AND GAS METER TESTING, by F. W. HARTLEY. \$1.60.	MANUAL FOR GAS ENGINEERING STUDENTS, by D. LEE, 40 cents.	PURIFICATION OF COAL GAS, by R. P. SPICE. 8vo. \$3.
GAS CONSUMER'S HANDBOOK, by WILLIAM RICHARDS, C.E.; 18mo., Sewed. 20 cents.	HOW TO MANAGE GAS, by F. WILKINS. Paper. 20 cents.	
A PRACTICAL TREATISE ON GAS AND VENTILATION with Special Relation to Illuminating, Heating, and Cooking by Gas, by E. E. PERKINS. \$1.25.		

The above will be forwarded by express, upon receipt of price. We take especial pains in securing and forwarding any other Works that may be desired, upon receipt of order. All remittances should be made by check, draft, or post office money order.

A. M. CALLENDER & CO., No. 42 Pine Street, New York.

GAS METERS.

GAS METERS.

GAS METERS.

GEO. J. MCGOURKEY, Pres. WM. H. MCFADDEN, Vice-Pres. (Phila.) WM. N. MILSTED, Gen. Supt. & Treas. (New York) WM. H. DOWN, Sec.

AMERICAN METER COMPANY.

WET AND DRY GAS METERS. STATION METERS. EXHAUSTER GOVERNORS. DRY CENTRE VALVES. GOVERNORS FOR GAS WORKS.

PRESSURE REGISTERS. PRESSURE & VACUUM REGISTERS. PRESSURE & VACUUM GAUGES. CRESSON GAS REGULATORS. MARSLAND WATER METERS.

METER PROVERS. PORTABLE TEST METERS. EXPERIMENTAL METERS. AMMONIA TEST METERS. BAR AND JET PHOTOMETERS.

Manufactories:
512 W. 22d St., N. Y.
Arch & 22d Sts., Phila.

GAS STOVES,
SUGG'S "STANDARD" ARGAND BURNERS,
SUGG'S ILLUMINATING POWER METER,
Wet Meters, with Lizar's "Invariable Measuring" Drum.

Agencies:
177 Elm Street, Cincinnati.
211 & 216 N. Wells Street, Chicago.
810 North Second Street, St. Louis.
222 Sutter St., San Francisco.

HELME & McILHENNY,

(Established 1848.)

GAS METER MANUFACTURERS,

Nos. 1339 to 1349 Cherry Street, Philadelphia, Pa.,

WET AND DRY GAS METERS, STATION METERS, EXPERIMENTAL METERS, METER PROVERS,

Center Seals, Pressure Registers, Governors, Indicators, Photometers, and all other kinds of Apparatus for use in Gas Works.

FOULIS' PATENT STATION AND DISTRICT GOVERNORS.

REPAIRING DEPARTMENT.—We employ a special force of skilled workmen repairing meters of all makers.

WM. WALLACE GOODWIN, Prest. and Treas.

WM. H. MERRICK, V.-Prest.

S. L. JONES, Sec.

S. V. MERRICK, Supt.

THE GOODWIN GAS STOVE AND METER COMPANY,

Successors to W. W. GOODWIN & CO.

1012, 1014 and 1016 Filbert St., Phila., Pa. 142 Chambers St., New York.

76 Dearborn St., Chicago, Ill.

WALDO BROS., Agents, 88 Water St., Boston.

MANUFACTURERS OF THE "SUN DIAL" GAS STOVES, FOR COOKING AND HEATING PURPOSES.

Dry and Wet GAS METERS, Station Meters (Square, Cylindrical or in Staves) Glazed Meters, King's and Sugg's Experimental Meters, Lamp Post Meters, Etc., Etc., Meter Provers (sizes 2, 5 and 10 feet), Pressure Gauges of all kinds, Pressure Registers, Pressure and Vacuum Registers, Pressure Indicators (sizes 4 inch, 6 inch and 9 inch), King's Pressure and Vacuum Gauges, Dry and Wet Centre Seals, Dry and Wet Governors, Exhauster Governors, Photometers of all descriptions. Letheby's Sulphur and Ammonia Test Apparatus complete—also Testing and Chemical Apparatus of all kinds, and of the most perfect description, for all purposes relating to Gas.

GOODWIN'S IMPROVED LOWE'S JET PHOTOMETER.

Agents for Bray's Patent Gas Burners and Lanterns.

Special attention to repairs of Meters, and all apparatus connected with the business.
All work guaranteed first class in every particular, and orders filled promptly.

G. B. EDWARDS, Mang'r, New York
E. H. B. TWINING, Mang'r, Chicago.
Represented by S. S. STRATTON.

D. McDONALD & CO.,

GAS METER MANUFACTURERS.

(Established 1854.)

51 Lancaster St., Albany, N. Y. 34 & 36 West Monroe St., Chicago, Ill.

STATION METERS, EXPERIMENTAL METERS, METER PROVERS, PRESSURE & VACUUM REGISTERS, PRESSURE GAUGES, ETC.

Also STAR GAS STOVES, RANGES, and HEATING STOVES.

We use only the very best materials, and employ the most skilled labor, and by our long experience (32 years) and personal supervision of every detail, we feel justified in assuring the public that our goods will give perfect satisfaction. Every Meter emanating from our establishment will bear the State Inspector's BADGE, and will be fully warranted by us. Our Annual and Calendar will be sent to Gas Companies upon application.

GAS ENGINES.

GAS ENGINES.

“Otto”

Gas Engine Works,

Schleicher, Schumm & Co.,

CHICAGO,

PHILADELPHIA.

New York Agency,

18 VESEY ST.

New “Otto”

Vertical Gas Engine,

GIVING

ONE HORSE POWER

ON THE PULLEY.

Price, - \$290

At Shops in

PHILADELPHIA.

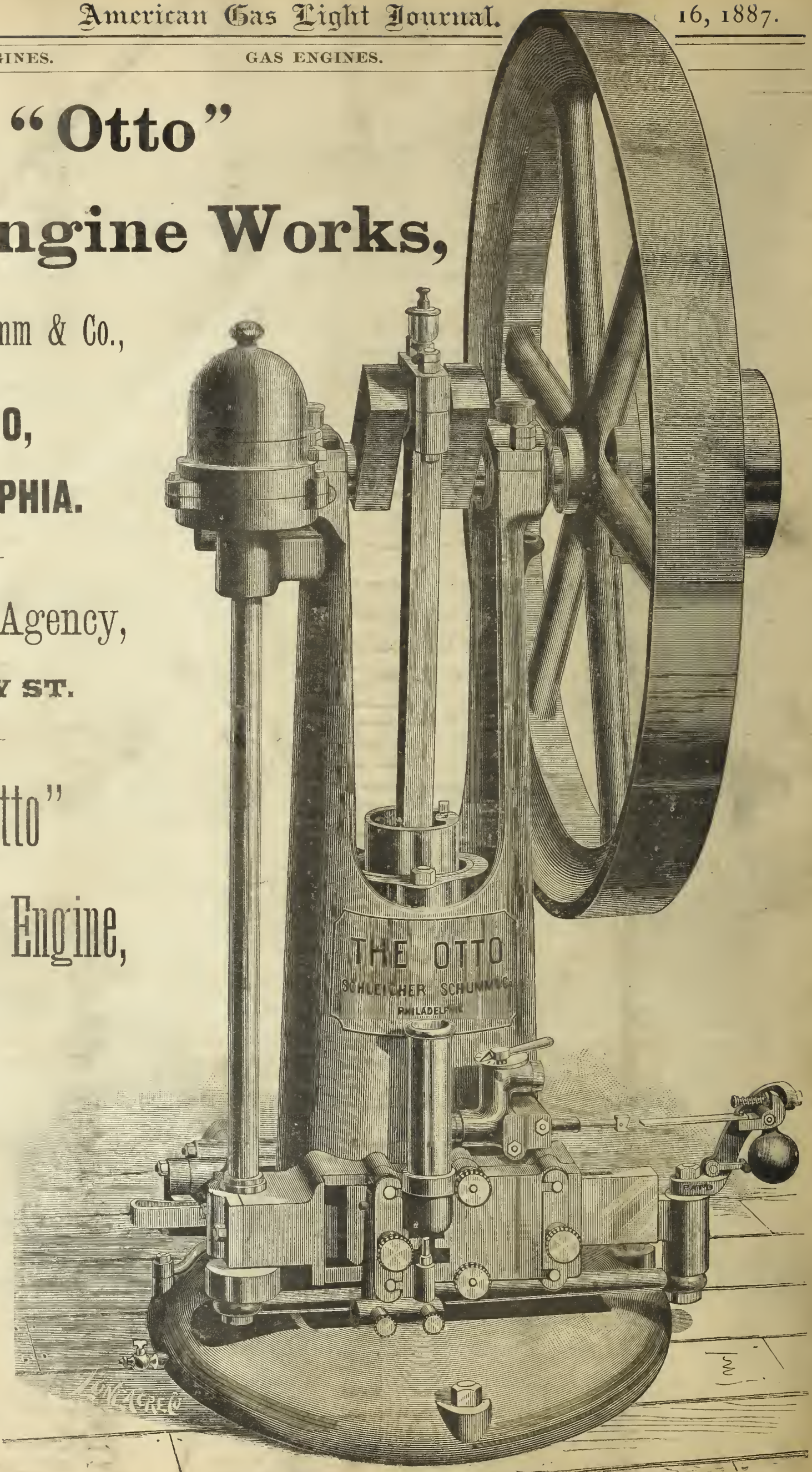

THE AMERICAN

GAS LIGHT JOURNAL

PUBLISHING OFFICE No. 42 PINE STREET

DEVOTED TO THE INTERESTS OF ILLUMINATION, VENTILATION, WATER SUPPLY AND DISTRIBUTION, & GENERAL SCIENCE.

VOLUME XLVII.—No. 11. }
Whole No. 683.

NEW YORK, FRIDAY, DECEMBER 2, 1887.

{ \$3 PER ANNUM,
IN ADVANCE.

A. M. CALLENDER & CO., Proprietors. C. E. SANDEBSON, Manager.
JOS. R. THOMAS, C.E., Editor. T. J. CUNNINGHAM, Asst. Editor.

ENTERED AT THE POST OFFICE AT NEW YORK, N. Y.
AS SECOND CLASS MATTER.

Published on the 2d and 16th of each month, at No. 42 Pine Street, N. Y.

Terms of Subscription, Including Postage.—For the United States and Canada, \$3 per annum. European countries, \$3.50 (15 shillings—18 francs). All payments to be made in advance. Single copies, 15 cents.

Remittances should be made either by post-office order, registered letter, or bank draft on New York, payable to the order of A. M. Callender & Co.

CONTENTS.

An Asterisk (*) denotes an illustrated article.

EDITORIALS—

A Self-Explanatory Correspondence.....	353
Candle Power and Castigation, by B. E. Chollar.....	354
*Structural Capacity and Cost of Gas Works, by V. Wyatt.....	355
Turning the Tables.....	360
Special English Correspondence.....	361

Sensational Gas Management—Cheap Gas—Purification *in situ*—Tar Useless for Gas Making—Gas for the Million—Reduction in Price.

ITEMS OF INTEREST FROM VARIOUS LOCALITIES..... 362

Annual Election, Rahway, N. J.—A Line from Pawtucket, R. I.—The Braddock (Pa.) Company Once More in Line—Public Lighting, Meridian, Miss.—The Kerr Murray Company's List—A Hint from Appleton, Wis.—Send In Your Names—Public Lighting, Alton, Ills.—Turned On—Inexpedient—Caught—Obituary Note—His Successor—Sold—A Lively List of "Western Walls," by Diaphragm—The Omaha (Neb.) Explosion—More Benefactors—The Sale of Natural Gas in the City of Morristown—An Interesting Legal Decision—Killed—What the Waterhouse Electric Manufacturing Company is Doing—Dismissed—Will They Go Back to It?—Consolidated—Cheaper Gas for Birmingham, Conn.

Notes from the West, by "Retort".....	365
Death of General E. W. Leavenworth.....	366
The Market for Gas Securities.....	366

A SELF-EXPLANATORY CORRESPONDENCE.

Widespread interest has been developed amongst the fraternity over the possibilities so much more than hinted at in the able and exhaustive paper on fuel gas as presented to the last convention of the American Association, by Mr. Emerson McMillin, Vice-President and General Manager of the Columbus (Ohio) Gas Light and Coke Company. If we mistake not it was but a comparatively short while ago that we felt called upon to dissent from a proposition that emanated in England regarding the status of our home engineers. The authority, and we readily concede its undoubted prominence and the signal ability of its conductors, was no less a one than the London *Journal*, but on the occasion in question we think its deduction was altogether wrong. Briefly stated the *Journal* gave as its opinion that American gas engineers seemed to be men of business first and engineers afterwards, and attempted to support that opinion from a study of their utterances at the various meetings of our gas associations. Perhaps the business feature does crop out prominently at such gatherings in this country, and with much greater frequency than is the case on like occasions on the other side of the water, but the conditions which govern the manufacture and sale of gas here and abroad widely differ. Quite frequently the engineer of a small and often of a medium or large-sized plant as well is also obliged to carry

on the executive management of his company's affairs. In fact, outside of our very largest centers of population and trade, the example in which the engineer or superintendent does not also write himself down as secretary or treasurer, or both, forms the exception and not the rule. With such a state of affairs, made necessary on the simple score of economy because of the facility possessed by the public of satisfying its artificial lighting needs by resorting to the greatest competitor of the American gas maker—cheap and good kerosene oil—it is therefore not to be wondered at that, in discussing subjects connected with gas engineering, the engineer will occasionally merge himself into the secretary or the treasurer. Indeed, we are not sure but these lapses result in benefit to the better mutual understanding of the topic under debate.

Aside, however, from all such speculations and explanations, we think both English and Continental engineers will find much to interest them in Mr. McMillin's fuel gas theories, or rather, practical suggestions. We are also disposed to offer it in evidence as proof that the technical and business divisions of gas manufacture need not necessarily be divorced when the manufacturers are gathered together in assembly to ventilate the progress of a year in their craft. We presume that now the subject of fuel gas has ten advocates and fifty students in America to the one attracted to it on the Continent, although it is quite likely that the reverse was the case some ten or even a less number of years ago. The wonderful natural gas developments in the Pittsburgh, Findlay, and other regions have taught us the great value and exceeding convenience of a gaseous fuel in the homestead as well as in the factory or the workshop. And while originally many were disposed to adjudge Dr. Siemens an enthusiast of the most pronounced type, when he suggested the approach of the day in which coal would be turned into gas at the pit's mouth, the followers of his theory at the present time are perhaps numerically as strong as were the doubters before. The prevailing opinion, and one that becomes stronger as it grows in age, seems to be against the idea that the tremendous volume of gas issuing from the bowels of the earth can be depended on indefinitely, or even remotely. In fact, some of those who have given much thought to the matter, including, if we mistake not, no less an authority than Dr. Orton, place the longevity of the wells not further off than another decade—a result that, should the estimate eventually prove well-founded, might have been warded off much longer had the most ordinary measures of economy been adopted in the handling and disposition of the product. Will the death of the natural current be accepted as a reason for returning to the unclean and bulky and wasteful heating systems pursued in the natural gas regions near to the coal fields prior to the birth or discovery and application of that current? We incline to the opinion that a negative answer must be returned to the query. When men like McMillin, and scores of others equally bright, ardent, and capable, are bending their minds and energies to the solution of the problem, we fail to see how success can long elude their efforts.

It was not our intention at the outset to refer at such length to the subject, but the question is one fraught with such important possibilities and probabilities as to cause it to take a firm hold on the thought, attention, and interest of our gas makers.

Unluckily, one of the calculations contained in the McMillin paper was incorrectly carried out, and the revision of the mistake causes quite a

difference to appear in the relative value of the components in the fuel gas mixture finally worked out. Our attention was attracted to the error by a correspondent, who forwarded the following:

NATIONAL TRANSIT CO., UNITED PIPE LINE DIVISION, }
OIL CITY, PA., Nov. 19, 1887. }

To the Editor AMERICAN GAS LIGHT JOURNAL:

In your issue of Nov. 16 appears a paper on "Fuel Gas," by Emerson McMillin, which I have read with considerable interest. In Table XIII. of that paper I notice what appears to be a serious error in addition, the cost of labor, repairs, and incidentals being given at \$2.043 per ton of coal, or 51,600 cu. ft. of mixed gas. It should be \$3.043, as will be seen by reference to the figures. This would increase the cost of gas in the holders about 25 per cent., with coal at \$2 per ton, and would make the mixed gas cost considerably more than coal gas for equal heating power. I trust, however, that Mr. McMillin will not give up the problem of producing a good and cheap fuel gas, although so far he seems to have failed to do so.

Truly yours, EDWIN SQUIRE.

Upon receipt of Mr. Squire's communication we forwarded a copy of the same to Mr. McMillin, in order that a reply thereto might accompany it. Mr. McMillin returned the following answer:

OFFICE OF COLUMBUS GAS LIGHT AND COKE CO., }
COLUMBUS, OHIO, Nov. 28, 1887. }

To the Editor AMERICAN GAS LIGHT JOURNAL:—I am in receipt of your communication inclosing letter from Mr. Edwin Squire calling attention to an error of addition in Table XIII of my paper on fuel gas. Mr. Squire is right, and while a correction of the error advances the estimated cost less than two cents per thousand cu. ft., yet that equals a large per cent. of the total. In the preparation of the paper I probably covered two pages of figuring paper for each single page of manuscript produced, and shall be surprised if many errors are not pointed out. I am neither surprised nor disappointed that a correction of the error pointed out should swell the cost per heat unit above the estimated cost of coal gas. In this same connection I called attention in my paper to the fact that the cost was nearly the same. The fact is, we will not be able to make a fuel gas that will be much cheaper in the holder than coal gas; and only natural gas can exceed coal gas in quality. However, there are reasons why fuel gas should be made.

First.—The loss by leakage is a much more serious one with coal gas than with a gas costing less per thousand feet; second, the public cannot be induced generally to adopt a high priced gas for fuel; third, in the estimates showing cost of making coal gas credit was given at present prices for residuals, while it is fair to suppose these could not be maintained if coal gas were made in sufficient quantities for fuel; and, finally, in all the estimates of manufacturing and distributing the mixed fuel gas a good, healthy margin was allowed over and above what experience in the manufacture of the gases separately, and recent experiments in the manufacture of the mixed gas, show the gas can be made for.

If the labor expended in the preparation of my paper awakens an interest as shall develop a better and cheaper gas, equally safe and salable, I shall feel amply repaid, and will hail the new system with joy. At present I am inclined to think the system suggested in my paper promises a commercial success, and that is what we are striving for.

Yours truly, EMERSON MCMILLIN.

Candle Power and Castigation.

By B. E. CHOLLAR, Topeka, Kansas.

"Which the same I am free to maintain."—*Bret Harte.*

The extracts in italics are from the paper read by Mr. A. C. Humphreys, M.E., at the late meeting of the American Gas Light Association, and have reference to a paper read by the subscriber at the last meeting of the Western Gas Association. It appears so evident that Mr. Humphreys did not fully comprehend the drift of my paper that I am in a way compelled to reply to his criticism. The purpose of my paper was to show: That the results obtained by the ordinary practice of photometry are, to a considerable extent, delusive and misleading; that they enhance the apparent value of small and intense lights, to the disparagement of those of larger size and lesser brilliancy; that the rule of inverse squares does not hold good with lights of considerable magnitude; that the light from a luminous area diminishes less rapidly than the square of the distance increases; that the energy exerted by a light should be represented by the product of two factors, one of which being increased, the other can be correspondingly reduced; that, irrespective of intensity, the light from a luminous body is independent of distance, and is in direct proportion to its diameter; and, lastly, that the true interpretation of the law should be something like this: The light from a luminous body is inversely as the squares of the distance and directly as its projected area.

Quoting Mr. H.: "I was surprised to find an intimation in Mr. Chollar's paper that the law was by some supposed to be based upon something outside of mathematics." Writers on gas and gas lighting have almost invariably expressed the law in such a way that the casual reader might infer it to be based on some inherent property or quality of the light itself—e.g., "The power of a luminous body to illuminate any defined space is inversely as the square of the distance."—*Clegg.*

"Wherefore recourse was had to the well-known law of optics, viz., that light varies inversely as the square of the distance."—*Bowditch.* "Its construction depends upon the well-know law of optics that the quantity of light thrown on an object by a luminous body is inversely as the square of their distances."—*Banister.* "That lights are to each other in the ratio of the squares of their distances."—*Hughes.* "The intensity of illumination is in proportion inversely to the square of the distance of the object from the source of light."—*Hartley.* Hence my illustration was not deemed superfluous.

Mr. Chollar then attempts to prove a new law in the place of our old friend which has stood by us for so many years, to the effect that irrespective of intensity the quantity of light is independent of distance. To say that the intensity of light only decreases with the distance can hardly be construed as an attempt to prove a new law, especially since the assertion is fully supported by the wave theory; for the amplitude of vibration (which produces intensity) decreases with the distance, while the rate of vibration (or wave length) does not.

The second diagram of the article is intended to produce this [the preceding], but if any of you will study the diagram, and bear in mind that every point of the line emits rays in every direction, you will see that the diagram affords no such proof. The proof is not in the diagram, for if it were, according to Mr. H., more lines diverging from more points would have had a tendency at least to strengthen it. The diagram referred to was intended to illustrate in a simple way that rays from a luminous body may converge at any given point, producing thereat the combined effect of as many luminous points as may be assumed to be contained in the luminous surface. Rays from a point cannot converge and reinforce each other, but must diverge and grow thinner as the distance increases.

Take the case of the opal globe. A certain percentage of the light is cut out, as claimed, but the distribution of light is much better by reason of the enlarged light-giving surface. Exactly so; our case is getting hopeful. The globe, by reason of its greater surface, produces a greater co-operation of converging rays than the naked flame. That is to say, the effect of the converging rays overbalances that of those which diverge or scatter. It is the effect of this concentrating of light energy, so-to-speak, from luminous surfaces that is not estimated by the rule of inverse squares.

I do not think that we shall be following out the proposed line of investigation by going out of our way to attack well-established laws of nature. An attack upon an established law of nature can only result as did the encounter of the bull with the locomotive. Common prudence would admonish one to avoid such a conflict. Preachers may differ among themselves in regard to the interpretation of scripture without becoming liable to the charge of heresy. Lawyers may disagree upon the construction of a statute without being regarded as attacking the law. So also the expression of an opinion in regard to the understanding of a law of nature. Even if the opinion be a trifle on the aggressive order, if supported by substantial evidence, in a respectful way, it ought certainly in a gas convention be tolerated, at least. In the discussion which followed the reading of Mr. H.'s paper, President Morton used the following language:

"Now, suppose that instead of being a point the source of light were a surface. Then, in the first place, it is manifest that the surface may be divided into an infinitude of points, and that what is true of each one of the points must be substantially true of the entire thing." The surface can emit series or systems as it were of converging rays, which continually condense and support each other, while the light from each point in detail must necessarily diverge and become more and more attenuated as the distance increases. Hence, what is true of the surface is not true of each individual point. Later on the President says: "In fact so that this amplitude or height of wave varies inversely as the square of the distance from its source." Here is a splendid chance for Mr. H. to also charge the President with an assault upon an established law of nature; for if the amplitude decreases with the square of the distance, and the intensity is directly as the square of the amplitude, it follows that the intensity at any given point is inversely as the fourth power of the distance. Again, the President says: "When we say that the candle power is the same we mean, that on testing with the photometer, and allowing the light to fall on a white surface, we get equal illumination of that surface. If it is true in the photometer it cannot be otherwise than true out of the photometer."

The photometer is based on the assumption that light in general decreases in proportion to the squares of the distance from its source. To prove a rule with an instrument based on the rule itself is like arguing in a circle.

If, however, a part of the light from a surface decreases less rapidly than in accordance with that law, then what is true in the photometer is not true out of it.

[Reprinted from the London JOURNAL.]

Structural Capacity and Cost of Gas Works.

By V. WYATT.

The address delivered by the President (V. Wyatt) of the North of England Association of Gas Managers, at the 21st half-yearly meeting of that Society, was of the following elaborate and eminently practical nature :

Gentlemen, I thank you for the compliment you have paid me by asking me to preside on the present occasion. In carrying out your

something comparable to the simple 5 per cent. return upon the outlay.

Description of Table.—In the table annexed hereto there are twelve columns giving the capacity and capital cost of the several structures and plant necessary for the manufacture of coal gas for the supply of a town or district, at per ton of coals carbonized, and per 1,000 cubic feet of gas made per diem, in December; and also the capital per ton and per 1,000 cubic feet for the year, reckoned as made up of 200 December average days. The table is compiled for capacity and cost of structures and plant for gas works in a similar form to those tables usually put forth

Structural Capacity and Cost of Gas Works and Plant per Ton of Coals Carbonized, and per 1,000 Cubic Feet of Gas Made per Diem in December. Also Capital per Ton and per 1,000 Cubic Feet per Year of 200 December Average Days.

1	2	3	4	5	6	7	8	9	10	11	12
Works, etc.	Capacity of Structure per Ton per Day.	Capacity per 1,000 Cu. Ft. per Day.	Cost per Cu. Ft. of Structure Complete	Capital per Ton per Day.	Capital per 1,000 Cu. Ft. per Day.	Area per Ton per Day.	Area per 1,000 Cu. Ft. per Day.	Capital per Ton per Year.	Capital per 1,000 Cu. Ft. per Year.	Ratios to Total Capital.	Remarks.
	Cu. Ft.	Cu. Ft.	s. d.	£	£	Sup. Ft.	Sup. Ft.	£	£		
Land				4.33	0.433	163.00	16.000	0.0216	0.0022	0.0077	2½ acres of land per mill. gas per diem.; £200 per acre.
Drains, boundary walls, etc....				4.06	0.406			0.0203	0.0020	0.0072	£188 per acre of site.
Retort house, coal stores, and retort ovens.....	6,000	600.00	0 4.00	100.00	10.000	Floor 100.00	Floor 10.000	0.5000	0.0500	0.1764	Carbonizing portion, 60; coal and coke stores, 40 per ct.; 1 ft. lineal of retort house per ton per diem.; stage house, 1 ft. lineal costs £100.
Condenser	33	3.30	2 7.50	4.33	0.433	Surface 50.00	Surface 5.000	0.0216	0.0022	0.0077	5 to 8 minutes contact, max. and av., 1s. 9d. per superficial ft. of area.
Boiler house and plant within.	120	12.00	0 11.00	5.67	0.567	Floor 3.85	Floor 0.385	0.0283	0.0028	0.0100	House 18, and boilers and plant 82 per cent. of cost.
Exhauster house and do.....	105	10.50	1 2.00	6.02	0.602	3.00	0.300	0.0301	0.0030	0.0106	House 25, and exhausters 75 per cent. of cost.
Scrubbers and washers.....	100	10.00	1 8.00	8.33	0.833	Sieves 10.00	Sieves 1.000	0.0416	0.0041	0.0147	12½ per cent. of scrubbers can be used as washers, 15 to 27 minutes contact, max. and av.
Purifying house	1,620	162.00	0 1.50	9.58	0.958	50.00	5.000	0.0479	0.0048	0.0171	
Purifiers	133	13.30	3 2.00	20.00	2.000	Sieves 100.00	Sieves 10.000	0.1000	0.0100	0.0353	4.00s. per sup. ft. sieve area; 15 to 27 minutes contact.
Lime and oxide sheds.....	810	81.00	0 1.50	4.79	0.479	25.00	2.500	0.0240	0.0024	0.0084	Half area of purifying house.
Meter house and do.....	174	17.40	0 7.00	5.30	0.530	3.85	0.385	0.0265	0.0026	0.0093	House 45, and meters 55 per cent. of cost.
Gasholder tanks	5,000	500.00	0 2.33	48.00	4.800			0.2400	0.0240	0.0847	Sm. tanks cost £5-£6 per 1,000 st'rge.
Gasholders.....	10,000	1000.00	0 1.50	58.15	5.815			0.2907	0.0291	0.1026	Large do. " £4 £5 " " Sm. hldrs. " £6-£7 " " Large do. " £5-£6 " "
Mains and valves on works				8.33	0.833			0.0416	0.0042	0.0147	
Railway communications				10.00	1.000			0.0500	0.0050	0.0177	5 lineal yds. railway per ton per diem, maximum.
Tar and liquor tanks.....	136	13.60	0 7.25	4.15	0.415			0.0207	0.0021	0.0073	£5 per 1,000 gallons of storage.
Workshops and offices.....	1,500	150.00	0 4.00	6.16	0.616			0.0308	0.0031	0.0109	
Tools and implements on works				8.75	0.875			0.0437	0.0044	0.0154	
Street mains and town distribution plant.....				162.32	16.232			0.8116	0.0812	0.2857	50 per cent. of previous items.
Engineer'g, sup'vis'n of works, law and parliament'y charges				36.46	3.646			0.1823	0.0182	0.0643	7½ " " "
Floating capital, stores, etc....				52.35	5.235			0.2617	0.0261	0.0923	10 " " "
Total.....				567.08	56.708			2.8350	0.2835	1.0000	
Margin for w'rks under repair & increased consump. =25 p.ct.				141.77	14.177			0.7087	0.0708		
Safe total				708.85	70.885			3.5437	0.3543		

wishes I have thought it more profitable for you, and most convenient to myself, that I should confine my remarks to practical points connected with gas works, and not trouble you with platitudes and speculations. I have, therefore, selected the subject of the actual cost of gas works plant, and their capacity or volume to carbonize and bring out the profits of a ton of coals by any company. If we can only control the cost of gas works and plant we can also regulate and economize the selling price of gas. The capital expended requires a fair interest for its outlay; and this interest is an important element in the cost of the gas to the consumer. I have thought recently that some leviathan companies are growing too anxious in upholding high dividends, and have too little thought for the consumer; so that sooner or later every item of cost per 1,000 feet of gas will be severely scrutinized. I anticipate that all large concerns will have to be satisfied, in future creations of capital, with

showing the annual cost of gas making. Each ton of coal in the table is for convenience of calculation, assumed to yield 10,000 cubic feet of gas; but no other data in the table are assumed, but simply deduced from my note-books, experience, and general observation, and are not ideal. I may explain at starting that the capacity of structure in cubic feet is arrived at by taking the *outside* dimensions of the buildings at the ground line, for area, and multiplying the same by the height thereof, from the ground line to half-way up the roof, in feet. These dimensions will give the true cubical contents or capacity of structure *visible* on the works. The foundations are not measured in; but the cost of these is included in the rate per cubic foot given in the schedule. If the foundations were included in the capacity, the quantity would be increased from 10 to 12½ per cent.; but the price per cubic foot would not, therefore, be reduced in the same ratio. The cost of foundations is generally about 5 per cent.

only of the total value of the structure. With these data you can either cube in the foundations or leave them out, as I have done, and estimate accordingly. The dimensions of the several iron vessels used on the works for purification, storage, etc., for capacity, are taken inside and with net measurement; but the cost per cubic foot includes the pipes, valves, connections and foundations immediately surrounding and in contact with them. The brick tanks constructed upon the works for storing tar and liquor, and also those to contain the gasholders, are likewise measured net *inside* the walls. No. 1 column in the table describes the character of the works and plant, including the several items of expenditure necessary for the full equipment of a gas undertaking. No. 2 column gives the capacity or volume of structure in cubic feet required per ton of coals carbonized per diem in the month of December. No. 3 column shows the capacity or volume of structure per 1,000 cubic feet of gas made per diem. No. 4 column gives the cost of structure at per cubic foot, measured as previously described. No. 5 column shows the capital expenditure for carbonizing each ton of coal per diem, in pounds sterling and decimals of a pound. No. 6 column gives the capital per 1,000 cubic feet of gas made per diem in pounds and decimals. No. 7 column shows the areas of land, floor surface, or sieves, in superficial feet and decimals per ton of coal per diem. No. 8 column gives the corresponding areas

Drainage, etc.—The items of "Drains, boundary walls, etc.," are put down in the schedule at the rate of £188 per acre of site—a price deduced from experience.

Retort House.—In the item of "Retort House, coal stores, and retort ovens" complete, a stage type of retort house is contemplated; containing within itself, in addition to the room for carbonizing, sufficient floor area to stock coal equal to three weeks' average consumption, which should be ample in these days of railways to insure constant and fresh supplies. If a greater stock of coal be required at any time of trouble or difficulty—such as anticipated strikes, or an abnormal rise in price—it is possible to store a surplus in the open for a time, under the high level viaduct, at the point marked on the sketch plan attached. There are 6,000 cubic feet of house capacity required per ton of coals carbonized per diem, at a cost of 4d. per cubic foot, all provided, being £100 per ton carbonized, and £10 per 1,000 feet of gas made per diem; with a floor area inside the walls of 100 superficial feet per ton, and 10 superficial feet per 1,000 cubic feet per diem, and a capital of 10s. per ton per year of 200 December days, and 1s. per 1,000 cubic feet. The cost per superficial foot of floor area is £1 for the house complete and fully equipped with carbonizing plant. Supposing a floor retort house were adopted—that is to say, one without stages and special coke holes—then this can be built

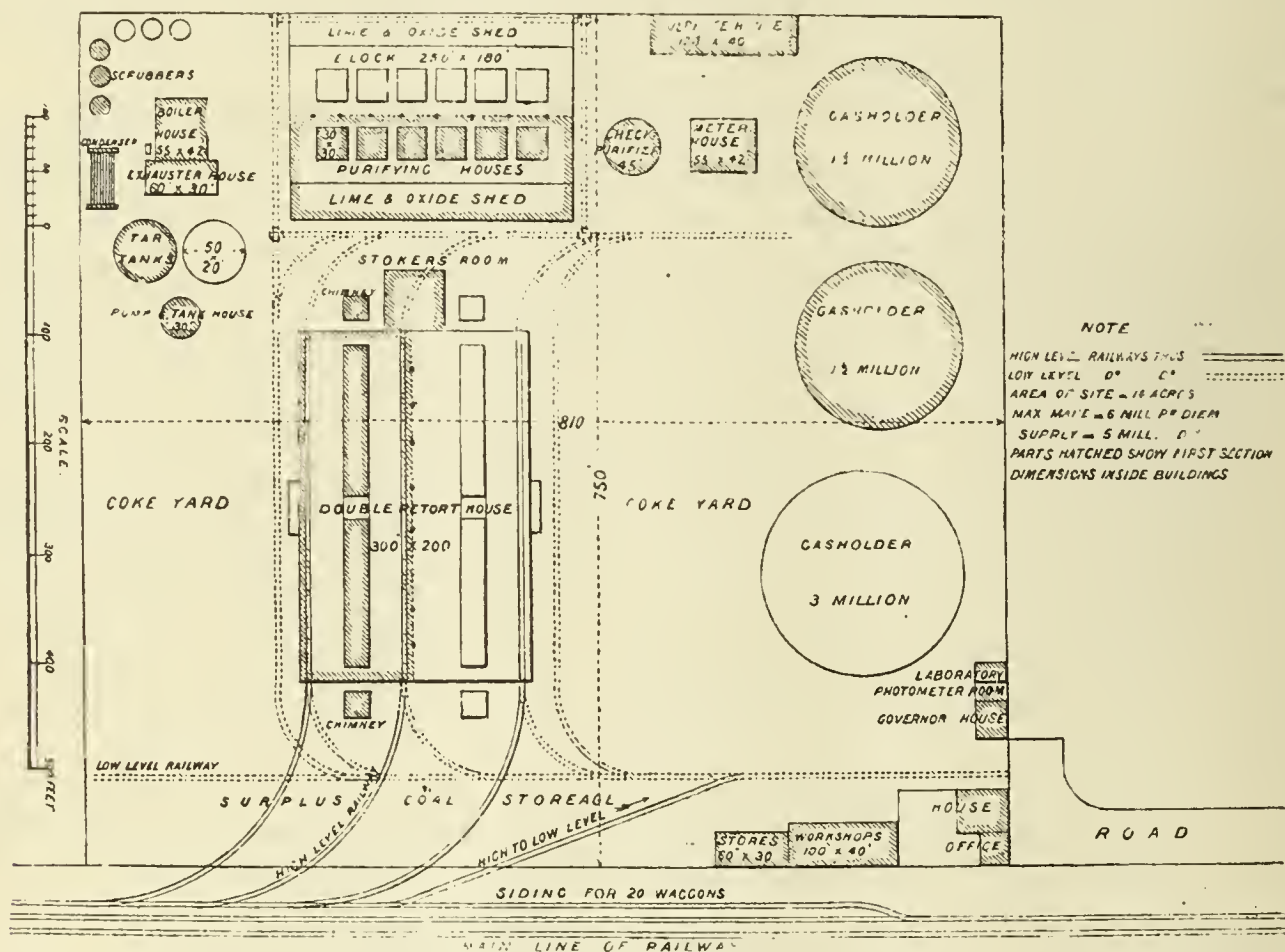

Sketch Plan of Gas Works.

per 1,000 cubic feet of gas made per diem. No. 9 column shows the capital expenditure per ton of coal carbonized per year of 200 average December days, in pounds and decimals. No. 10 column gives the capital per 1,000 cubic feet made per year. No. 11 column shows the ratio of cost which each item of expenditure bears to the total capital of the undertaking. No. 12 column is for the remarks and explanations to the several items, giving such information as cannot be conveniently brought into the previous columns.

Land.—The first item of expenditure in the list is for land. The quantity taken is at the rate of $2\frac{1}{2}$ acres for every 100 tons of coal carbonized, and each million cubic feet of gas made per December day; and it is rated at £200 per acre. Get three acres per million cubic feet per diem if possible; and also have regard to the ultimate wants of the district, to avoid difficulties in the near future. This item of the capital is the most uncertain for valuation, and depends upon position or contiguity of the works to the population, and "land sharks." Anything from £100 to £1,000 per acre may be screwed out of a gas company if it be so imprudent as to locate its establishment within even smelling distance of a large aggregate of human noses. A good rule to follow for the location of new works is, when the land is fetching more than £200 per acre near a proposed site, to get further away, and spend something extra on the leading mains from the works, as cast iron is cheap nowadays, and distance from a town is frequently an advantage, if not "an enchantment to the view."

at a cost 25 per cent. less than for a stage house. But (and here comes the pinch) you cannot then work economically and expeditiously in the carbonizing department—the waste of coke and amount of breeze produced is greater, and the labor is muddled and crossed, do what you will. The stage house has its own coke as well as coal stores; and these are great features of economy and comfort in working. The table gives one foot lineal of complete retort house to each ton of coal carbonized per day, and this foot costs £100, and yields gas enough for 500 people for a December day. There are, however, exceptional days in December and January when the demand in manufacturing districts reaches 50 per cent. more than this, which has to be met with by an excess of gas storage capacity upon the works. The retort house complete runs away with 18 per cent. of the total capital. The retort house shown on the sketch plan is a double or twin one, or rather two houses parallel with each other, united by a central line of columns, and where one line of high level and one of low level railway does double duty through the center line of the houses. You can, of course, have the single and isolated lines of retort houses, with the extension placed end on, instead of being twinned together. This plan is the superior of the two for ventilation and comfortable working; but it is slightly more expensive than the coupled houses. The cost of the retort house and coal stores combined, *exclusive* of retort ovens and fittings, is about 3d. per cubic foot.

Condenser.—The item "Condenser" in the table shows 33 cubic feet of capacity and 50 superficial feet of surface to the apparatus, and a capital

of £4.33 per ton of coal carbonized per diem, with a contact time for the passing gas of 5 to 8 minutes, maximum and average makes. Sometimes 50, and even (on the Continent) 100 per cent. more than this provision is allowed; but such happens where the condensers are formed of thick cast iron pipes, and not with thin wrought iron sheet tubes. With Newcastle coal the smaller proportion is sufficient; but with Midland and some other coals which throw down more tar and liquor, more area of condensation is necessary. It is important to keep in view the fact that the efficiency of the condenser is in proportion to the time of contact, and the capacity or volume of structure to bring about this time—in other words, to secure the slowest possible speed to the gas current, consistent with a reasonable outlay. A condenser built up of large tubes 2 feet diameter, having the same external surface, and the same weight of iron as one that is constituted of small tubes of 6 inches diameter, gives four times longer contact, and costs less money to erect. This is simply owing to the greater internal capacity of the larger tubes, in the proportion of over 4:1, with the same expenditure of material. Here volume of structure and time comes in, and tells in efficiency, as we shall see further on; forming an important factor in the various stages of gas manufacture. To effect important changes, nature demands time and repose; and so do the feeble efforts of man require the like to induce perfection and success. The gas, however, in traversing the larger tubes, is not so much *frictionized*, or tortured, as with the smaller ones; but this valuable quality we can compensate for by introducing intercepting screens in the interior of the inlet tubes or corner pilasters of a built-up condenser, and so cut up the current of gas into minute jets or streams. The cost of a condenser, formed with the larger tubes of thin wrought iron $\frac{3}{8}$ -inch thick, is about 1s. 9d. per superficial foot of condensing surface, at present prices. The annular form of condenser does not radiate off the same amount of heat from the gas in a given time as does the simple straight horizontal tubular condenser, metal for metal, and cost for cost. Sometimes there is placed on the works to take the current of gas after passing the exhausters an additional condenser, cooled with water, with about half the cubic capacity of the air condenser, which can be readily thrown into and out of use, according to the season of year, to temper the gas previous to entering the scrubbers, and to correct any increase of warmth given to the gas by the speed of the exhauster. In fact this water condenser is the *check* vessel of purification at this point of manufacture.

Boiler House.—The item of "Boiler house and plant within same," shows 120 cubic feet of structure or building to house the boilers and details, with a capital of £5.67, and a floor area of house equal to 3.85 superficial feet per ton per diem. The cubical contents of the boilers (outside net measurement) should be not less than 5 cubic feet per ton per diem, of the double-flued type of boiler. Of the total expenditure for this item the house and chimney represent 18 per cent., and the boilers, settings and connections 82 per cent.

Exhauster House.—The item of "Exhauster house and plant within" gives 105 cubic feet of building structure to house in the exhausters, engines and connections, with a capital of £6.02, and a floor area of 3 superficial feet per ton per diem. Of the total expenditure the house represents 25 per cent., and the exhausters, engines, etc., 75 per cent.

Scrubbers.—The item "Scrubbers and washers" shows 100 cubic feet of internal capacity of vessels, and a capital of £8.33 per ton per diem, with a gas contact of from 15 to 27 minutes, maximum and average makes. This is an ample provision of scrubbing power; and $12\frac{1}{2}$ to 15 per cent. of this volume can be used and adapted as a washer by simply introducing into the bottom of the scrubber a washing compartment, to intercept the tarry matters and other impurities from the foul gas as it enters each vessel. Some engineers think that 75 cubic feet per ton per diem is sufficient—that is to say, they use two scrubbers in the line of gas current instead of three, with a washer as an adjunct. Where, however, three scrubbers are employed the last one can be operated as a *check* scrubber, for the purpose of taking out the last traces of ammonia from the gas before advancing to the purifiers; and also to take in the regulated quantity of cold water to insure good scrubbing, as well as to govern the temperature of the gas below 60° F. in summer, and over 40° F. in winter. The volume of gas contained in the scrubbers at one time amounts to about 1 per cent. of the maximum make per diem, to give the requisite contact time. The horizontal net sectional area of all the scrubbers is equal to 2 superficial feet per ton per diem on the maximum make. About one-fourth, or 14 pounds, of the total impurities in the foul gas—such as ammonia, carbonic acid, sulphuretted hydrogen, and sulphur compounds—in all about 56 pounds (or $\frac{1}{2}$ cwt.) per ton of Newcastle coal, are intercepted by the scrubbers; and they, therefore, become valuable as general purifiers of the gas, in addition to their special duty as ammonia abstractors, when judiciously worked. Ample

volume in this branch of gas manufacture irrespective of mere scrubbing material, is as important as with the other sections; and capacity tells in efficiency. However, the chief duty to be looked for from the scrubbers is the production from a ton of Newcastle coal of not less than 25 gallons of 10-ounce liquor and 22 pounds of sulphate. Square and six-sided (hexagonal) scrubbers can be conveniently used sometimes, grouped in line or in clusters, isolated, or even united together as twins or triplets, to effect economy of material, space and cost.

Purifying House.—The item of "Purifying house" shows 1,620 cubic feet of building structure to cover in and house the purifiers from the weather, with a capital of £9.58, and a floor area of 50 superficial feet per ton per diem. The possession of a purifying house upon the gas works is deemed by some officials as a luxury that should be ignored; and consequently in many large works it is dispensed with, and this item of capital saved. In such an event, the purifier covers are upheld by catches during the time of changing the purifying material, as a temporary roof. The purifying house is, however, one of the least expensive buildings upon the works; costing only $1\frac{1}{4}$ d. per cubic foot of structure.

Purifiers.—The item of "Purifiers" gives 133 cubic feet total of vessels, internal capacity; and a capital of £20 per ton per diem, with a gas contact for the whole range of purifiers of from 15 to 27 minutes, maximum and average makes. The sieve area enclosed in the boxes is equal to 100 superficial feet per ton per diem. Taking the top area on the plan or horizontal section of one of the purifiers in a series, the allowance of 3 superficial feet of area per ton per diem is sufficient. The price of 3s. 2d. per cubic foot of box or structure includes the sieves, valves, pipes, and other details inside the house to operate the system. Taking sieve area only as a basis of cost, the value of a set of purifiers can be arrived at by pricing them out at about 4s. per superficial foot. The capacity of the purifying material is about one-third that of the box. In some gas works where the sulphur compounds, other than sulphuretted hydrogen, must be in great measure eliminated, as much as 150 cubic feet of boxes per ton per diem is provided. In the most advanced works the gas current passes through a group of from six to eight purifiers, and filters through a total thickness of from 15 to 20 feet of lime and oxide, and is allowed a time of contact of from 17 to 30 minutes. Any number of purifiers in a series are used by gas companies, varying from four to eight. The number of boxes employed is an index of how far the sulphur has been removed from the gas, and how many grains per 100 feet of gas are going to the consumer, ranging from 5 to 50, as well as from 0 to 3 per cent. of carbonic acid, which latter means about one-eighth of the light. No reasonable expense should be spared in the purification of the gas; and the time should have passed when gas is sold containing more than 10 grains of sulphur in each 100 cubic feet. We hear of the sulphur occasionally in some large districts reaching to over 40 grains, and the carbonic acid to nearly 3 per cent. Some people, including analysts, say that this does not pollute the air of dwellings; but they should be ashamed of this, and only whisper it to the marines.

Lime and Oxide Sheds.—The item of "Lime and oxide sheds" shows 810 cubic feet of building structure for covering in, storing and preparing the lime and oxide for service in the purifiers, with a capital of £4 79, and a floor area of 25 superficial feet per ton per diem. The total area of the lime and oxide sheds is one half that of the purifying house proper, which they adjoin, and is sufficient for all the purposes of lime preparation and oxide revivification.

Meter House.—The item of "Meter house and plant" contained in it shows 174 cubic feet of building structure to house in the station meters, with a capital of £5.30, and a floor area of 3.85 superficial feet per ton per diem. Of the total expenditure the house represents 45 per cent., and the station meters and connections 55 per cent.

Gasholder Tanks.—The item of "Gasholder Tanks" gives 5,000 cubic feet of structure, measured inside the walls, with a capital of £48 per ton per diem. The cost in the schedule is given at $2\frac{1}{4}$ d. per cubic foot of capacity; but if the tanks were of the largest type they could be constructed at 2d. per cubic foot. The larger the tank the cheaper the rate of the unit. Thus small tanks under 150 feet diameter cost from £50 to £60 per ton per day, equal to from £5 to £6 per 1,000 cubic feet of storage of the gasholder; while large tanks of 150 to 200 feet diameter cost from £40 to £50 per ton per diem, equal to from £4 to £5 per 1,000 feet of storage, according to the difficulties met with in construction. Brick tanks are to be preferred as a rule, built and flushed up solidly at every joint with Portland cement mortar, unless the locality presents most favorable materials for a concrete tank, which can be constructed reliably if a free use of hoop iron be used to prevent cracks and bind the whole together. I hope, from details I have prepared, in the future to build tanks in concrete sections, veneered with a skin face of brickwork in cement, dis-

pensing with heavy timbering in the trenches, at one-half the cost of the gasholder and framing, instead of about five-sixths, as at present.

Gasholders.—The item of "Gasholders" shows 10,000 cubic feet of capacity, or available gas storage, with a capital of £58.15 per ton per diem, and a cost of structure of 1½d. per cubic foot. In large and small holders there are generally about 20 pounds weight of wrought iron used per superficial foot net of sheeting plates to the side and crown, inclusive of the external framing for guiding the gasholder. Of this about 12 pounds is due to the holder proper, and 8 pounds to the framing. This is assuming that a wrought iron and not a cast iron framing be used; and as cast iron is an unreliable and brittle material, it is to be hoped it will die out in its application to holders. The total weight of wrought iron in a gasholder and framing complete is from 6½ cwt. (½ ton) for the larger sizes, to about 8 cwt. for the smaller, per 1,000 cubic feet of available storage. But the weights of wrought iron used per super-

be effected by full storage. Tanks and gasholders form an important element in the total capital amounting to nearly 20 per cent.

A few words as to the construction of tanks and gasholders. Supposing we take the example of a large holder with a capacity of 5 or 6 millions cubic feet, and work out its proportions, figures and strains carefully, at the same time throwing aside all opinions and authorities, and apply the results to the two systems of construction—viz., with two lifts, and with three lifts. In the first place the tank for the two-lift holder will cost only about 20 per cent. more than that for a three-lift one; but the wrought iron guide framing of the three-lift holder will require to be nearly twice the strength of the framing to the two-lift, which I will explain by diagrams of the two erections. (See diagrams Nos. 1 and 2). There is 50 per cent. more leverage to take hold of the wind pressure in the three lifts; and the strength of structure to meet this must be carried throughout the greater height of framing, and into all its details. The net result of all the calculations for the two structures would be that the three-lift holder costs, when all things are fairly priced out, at least 12½ per cent. more than the two-lift example of the same volume. I am here assuming Board of Trade rules for the iron scantlings and wind pressure, a factor of safety of 4, and an extreme gale force of ½ cwt. per superficial foot of vertical section to holder. Some people do not believe, or I should rather say will not believe in such a storm; but, for all that, nature does, and we generally have to follow her instead of the few, and to her we must submit. Recollect also (and this I have not taken into account) that "the wind bloweth where it listeth," and blows stronger at a height of 100 feet than it does at 66 feet—a fact which all sailors know who go up the rigging of ships, and so do workmen who repair chimneys. The wind gauges also declare this. Going up into the air with structures conduces to neither economy of material nor to facile building. The area of sheeting plates, or skin, for gasholders is greater for three than for two lifts; and this is the item of cost, do what we will, which runs away with the money—for, taking the floating weight of a holder by itself, the sheeting alone amounts to more than one-half of the entire weight. Also the three lifts have more complication in their construction, a greater number of parts, 50 per cent. more rollers and carriages to look after and grease, and be troubled with, a cranky, knock-kneed middle lift, with imperfect posts and stiffeners, as there is not room enough in the construction to get in the requisite muscle, and how are you to approach the spaces between the lifts to do the repairs? I note from an old edition of the "Encyclopædia Britannica," published more than 30 years ago, an illustration of the three-lift holder, with the open-webbed standards or guides, which we all pride ourselves as being so modern and original, and everybody says he invented; but they are of cast and not of wrought iron. We also recollect the original of this at the old City of London Gas Works, now defunct, and which I helped to pull down about 20 years ago, and send out of the country forever. Just another word or two about stiffening or trussing the crown of a holder, in opposition to the bladder-topped form. The trussed crown renders the structure self-contained for either storage purposes, under a gale, or when under repair, without inflation. The amount of wrought iron required for this special duty is only 6 per cent. of the total weight of framing and holder proper. The temporary crude props and wooden framing now used in some tanks to support the flabby sheeting of the crown when the holder is on its bearings in the tank, cost, when only decently performed, 12½ per cent. of the total value of the complete holder and framing. Also in dispensing with the crown stiffening, the top curb and crown sheeting must be strengthened. Only imagine a large railway station roof supported throughout its area by a network of wooden props and framing because it was so very convenient and cheap!

Mains and Valves on Works.—The item "Mains and valves on works" gives a capital of £8.33 per ton per diem. The pipes used about the gas factory are generally too small for the sudden accumulations of naphthaline and tarry matters which take place in them at times. The sectional area of the main to each independent section of the manufacture should not have a less sectional area of gas-way than 150 superficial inches per million cubic feet maximum gas make, or 1½ superficial inches per ton of coals carbonized per diem. In the arrangement of these mains, at points of intersection, it is better to provide roomy cross-over chests, instead of flattening the pipes, and "ducking" one under the other.

Railway Communications.—The item of "Railway communications" and rails to transport on to the works in detail from the main line of railway all the necessary materials used in the manufacture of gas—such as coals, lime, oxide, building materials, etc.—and to form an exit for coke, breeze, tar, sulphate, and other products—shows a capital of £10 per ton per diem. The importance of this item will be fully realized by noting the arrangement on the plan annexed hereto for works with a

No 1.

No 2.

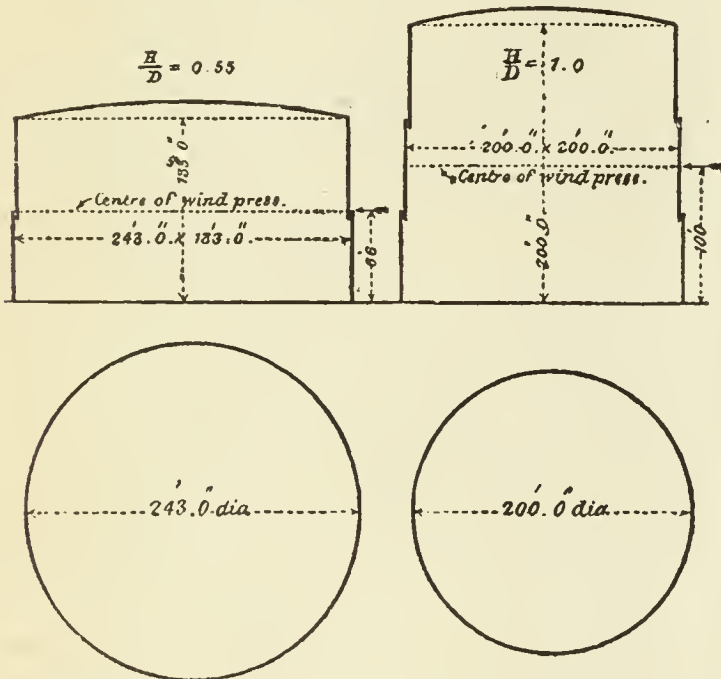

Capacity	6½ million cu. ft.	Capacity.....	6½ million cu. ft.
Area of skin (side and crown)	147,612 sup. ft.	Area of skin (7 per cent. more than No. 1)...	156,800 sup. ft.
Vertical sectional area	32,319 sup. ft.	Vertical sectional area	49,000 sup. ft.
Stability, 32,319 × 66 = 2,133,054.		= 24 per cent. more than No. 1.	
Tank cost 2½ per cent. more than No. 2.		Wind leverage = 50% more than No 1 and nearly twice the strength of framing.	
Land cost 33 per cent. more than No. 2.		Stability, 40,000 × 100 = 4,000,000.	
Area of base	46,058 sup. ft. = 68 p. ct. more than No. 2.	Area of base	31,200 sup. ft.
		Excess of cost for tank and holder, 12½%.	

	H.	D.
A good proportion is	H	D
	= 0.50 = ½ to 1.	
A better is.....	H	D
	= 0.66 = ⅔ to 1.	
Many holders are.....	H	D
	= 0.33 = ⅓ to 1.	

ficial foot of skin for the majority of holders should not vary much from the standard given, as the chief item of iron work is the sheeting, and this for both large and small holders is alike—viz., ¼-inch thick. It is volume which cheapens the rate per cubic foot of gasholders. The Leviathan gasholders with their framing have been constructed complete with ¼ ton of wrought iron per thousand cubic feet of storage; but I fear the factor of safety in such examples under a 56 pounds wind pressure, is short of 4:1—the universal factor recognized in iron structures both by the Board of Trade and practical engineers. Some gasholders, I know, have a doubtful factor of safety of 2. The cost of a gasholder and framing—all ironwork—per superficial foot of skin (side and crown) is about 3s. for a gasholder containing 2 million cubic feet, and £5 5s. per 1,000 cubic feet, available storage; and with tank, all complete ready for storage, 5s. 4d. per superficial foot of sheeting at current prices. The cost of the gasholder and tank combined may be estimated for moderate-sized holders at £10 per 1,000 cubic feet of storage—that is to say, a holder and tank for 2 million storage will cost £20,000, which is easy to remember. The 1 million cubic feet holder and tank may cost £12 per 1,000 feet (holder, £6 10s., tank, £5 10s.); for it must be remembered that the sheeting or skin surface of a 1 million feet holder is only two-thirds that of a two-million feet one. The storage in the table is taken for an average day's make in December; but in manufacturing towns this should be increased 50 per cent.—say, 1½ days' make—otherwise the carbonizing power of the works must be increased. Efficient carbonization can only

yield of 5 millions cubic feet of gas per diem. The high-level viaducts leading from the main line of railway, external to the works, to carry the coals direct into the retort house without trans-shipment have each a single line of railway, and average 8 yards in height and $4\frac{1}{2}$ yards broad at the rail level. With cast iron columns, wrought iron superstructure, and permanent way complete, of a substantial character, the cost is about £15 per lineal yard, including foundations. If the outside dimensions of the structure be cubed up the cost will be about 4d. per cubic foot. Taking the high and low level lines together on a fairly large establishment, there are necessary, to do the day's work with expedition and comfort, 5 lineal yards of railway per ton of coals per diem; or 500 lineal yards per million feet of gas made per diem. The low-level lines need not cost more than 15s. per lineal yard complete, including steel rails 56 lbs. ($\frac{1}{2}$ cwt.) to each yard of rail, equal to 1 cwt. for a pair of rails, sleepers, and ballast. The gauge of the lines should be the almost universal gauge (conventional though it be) of 4 ft. $8\frac{1}{2}$ in. between the rails, excepting for the sharp curves upon the works, where the clearance should be 4 ft. 9 in. The proportion of high level to low-level lines on the works may be taken at about one-third.

Tar and Liquor Tanks.—The item of "Tar and liquor tanks" shows 136 cubic feet of structure, measured inside the walls, with a capital of £4.15 per ton, per diem. The cost in the schedule is 7 $\frac{1}{2}$ d. per cubic foot of capacity—about three times that of a gasholder tank; and about £5 per 1,000 gallons storage. There are provided 850 gallons of storage per ton, per diem; but this quantity may be usefully extended to 1,000 gallons for the same duty.

Workshops, Offices, etc.—The item of "Workshops and offices" gives 1,500 cubic feet of structure, with a capital of £6.16 per ton, per diem, and at a cost of 4d. per cubic foot. A dwelling house is included in this item.

Tools, etc., on Works.—The items of "Tools and implements on works" are set down at a cost of £8.75 per ton per diem.

Street Mains and Distribution Plant.—The item of "Street mains and town distribution plant" shows a capital of £162.32 per ton per diem, being about 30 per cent. of the total expenditure on the entire undertaking. This item is a large one, and comprises all the works in the town and district after the gas mains have left the works proper. If we take a weight of about 1 cwt. of cast iron pipes per head of the population to be supplied, it will be sufficient for the canalization (as the French call it) or piping of a town, where the mains and services are judiciously laid down, and not, as they were in the early days of gas lighting, in haphazard fashion, where 33 per cent. of the pipes are old metal, and not earning money. The weight of piping in some districts reaches as high as $1\frac{1}{2}$ cwt. per head of the population. There are towns in which it would be good policy to take up in sections the whole of the street mains, and relay them on good lines and proportions, and so save leakage; bringing the latter down to something approaching 5 per cent. of the make, and not, as in some towns, from 16 to 18 per cent. The leading mains from the works to the margins of district should have a sectional area of not less than 175 square inches of pipe section per million cubic feet per diem, so as to run the day's make of gas into the heart of the district in $4\frac{1}{2}$ hours' time. At least 33 miles of street mains should be provided per million cubic feet of make per diem, or $\frac{1}{3}$ mile per ton per diem, of an average diameter of from 5 inches to 6 inches; and, approximately, from 25 to 30 tons of cast iron pipes for the same duty. Each mile of main should supply a population of 1,500 persons, and distribute the yield of gas from 600 tons of coal per year. Some manufacturing towns at the present time exceed this by about 20 per cent.; the average, however, is about 400 tons of coal carbonized per year to each mile of main. The number of consumers per mile of main may be assumed at 150, one meter to each ten of the population, and the day's make in December at 20 cubic feet per head. On extraordinarily dark days the consumption figure may run up in dense districts to 30 feet per head of the population; but on these days the storage is heavily drawn upon, and so equalizes the December make. Hence the necessity for a storage in some towns equal to $1\frac{1}{2}$ days' make of the same month. The leakage in gas mains can be largely reduced by the gas company doing its own main and service laying and repairs, and not by contract, in the same way as the railway company does with its permanent way. The gas pipes are the carriers of the staple article—gas—sent forth by the gas company, and must be as perfect as possible in their joints and details. The leakage of gas, alone in London, in one year, would nearly supply Newcastle-on-Tyne. The public lamps should be liberally supplied, and the cocks and governors kept free from naphthaline and carbon clogs; allowance and compensation being made in the delivery to each lamp for accidental stoppages, and so please our customers—the public—instead of creating the impression abroad that they are being "done." The

gas flames in some towns, and even in the Metropolis, are very sickly-looking and split up at some seasons of the year, and this goes on for weeks together. The consumers' meters and the services to them should be free, and throw in some economical and light-saving burners; so that all the customers may exactly know what they are to pay per 1,000 cubic feet for the gas consumed. Wipe out the extras from gas accounts, as they suggest the grasp of monopoly. These concessions will sweep away much of the petroleum and oil lighting, which is now so extensively used in the manufacturing towns and the Metropolis. In London only half the total number of houses are supplied with gas; and there are enormous stores of petroleum in the Metropolis to supply artificial light, which should be superseded by well purified and cheap coal gas. Do not give so much attention to the payment of dividends of over 12 per cent. We may get up some fine morning and find that some impatient man, with a restless intellect, has conceived a practical scheme for turning into cheap light the vast stores of petroleum existing in the world, which may yield, from the crude oil, 30 to 70 per cent. of illuminating or kerosene oil. The supply appears to be unlimited. One new field is described as "having an area of hundreds of square miles saturated with petroleum and asphalt, which flows in streams through dense forests, and emits inflammable gas, bursting into flame sheets, like the Caspian region, which latter dates from thousands of years ago." Tank-ships to carry this oil can be propelled on the high seas by a motor whose power may come from its own floating cargo; and the freight charges may be nominal. *Cave petroleum.* Refined, good burning petroleum is now talked of at 3 $\frac{1}{2}$ d. per gallon. We must not frighten ourselves further on this subject, but make up our minds to produce cheap gas, and go on to the next item.

Engineering and Parliamentary Charges.—The item of "Engineering supervision of works and parliamentary charges" gives a capital of £36.46 per ton per diem; being about 7 $\frac{1}{2}$ per cent. on the capital. This charge is a somewhat elastic one, and depends much upon the pugnacity of the population one has to do with, as well as the conscience of the engineer.

Floating Capital.—The item of "Floating capital, stores, etc.," shows a capital of £52.35 per ton per diem. This charge can be kept under by good business arrangements, and looking up sharply the quarterly accounts of the consumers.

Margin for Safe Working.—The total capital per ton per diem of all the preceding items amounts to £567.08 per ton of coals carbonized per diem, which equals £56.708 per 1,000 cubic feet per diem; per ton per year, £2.835; and per 1,000 feet per year, £0.2835. But then for the safe working of the undertaking, and to allow for works under repair, and increased consumption pending further extensions of the works, I have added at the bottom of the table 25 per cent. to produce what I call a safe total expenditure. The items include sound structural works—something better than "lath and plaster." We therefore arrive at a capital of £708.85 per ton per diem, and £3.5437 per ton per year, which should be ample to fit out and equip a gas undertaking to carry on a profitable business. You will please note this fact, that many of the larger gas companies in the land are only earning money from actual works which represent about 66 per cent. of their reputed capital. The other 33 per cent. ought to have been wiped out, and written off their accounts long since, and should be considered as used up, senile, affected by *anno domini*, or non-existent. They have only from £3 to £4 of value in useful constructions to show for their money per ton per year—something like the "reputed" pint bottles of beer when compared with "imperial" pints.

Percentage of Cost of Works.—Taking the capital as a whole, the percentage expended on carbonizing plant is about 18; mechanical plant and buildings for same (boilers, exhausters, and meters), 3; purifying plant and buildings, 8; gas storage, 20; distribution, 30; and sundries, 21—total, 100.

Cost of Buildings and Plant by Floor Areas.—The cost of the several buildings used about gas works may be readily estimated by taking the areas of useful or available floors, inside the structures, in superficial feet, and with these divide the cost of house and plant. Thus, for the retort house, coal stores, and plant inside, £1, boiler house and plant £1.51, exhauster house and plant £2, station meter house and plant £1.38, purifying house and plant £0.59, and oxide and lime sheds £0.19 per superficial foot of floor space, will be found sufficient to cover the cost.

Prices for Valuation Schedule.—The following are the several prices for works and materials, provided and fixed in the structures complete, which have been adopted in arriving at the cost per cubic foot of structure in the table annexed hereto: Land, £200 per acre; excavations for foundations in buildings at 10d., and for tanks at 2s. 6d. per cubic yard;

Portland cement concrete, 10s. 6d. per cubic yard; ordinary brick-work in mortar, 21s. per cubic yard; the same in cement, 26s.; brick-work of a mixed character, common and firework 30s. per cubic yard; ashlar stone, 4s. per cubic foot; firestone, 5s. per cubic foot; deal timber, 2s. 6d. per cubic foot; oak, 5s. 6d. per cubic foot; square of Duchess slating (10 ft. by 10 ft.), 30s.; and special brick paving, with 6 inches thick of concrete, to floors, 5s. 6d. per superficial yard. A bench of ovens cubed up from outside dimensions above the floor line, costs 2s. per cubic foot, including arches, retorts, and fittings complete; cast iron in stage plates, columns, and other forms, from £5 10s. to £10, with an average of £8 per ton; wrought iron, at an average of £16 per ton; and steel rails, £8 per ton. The cost of main laying complete, all materials and labor included, may be taken at £7 per ton of cast iron, and embracing all trench work. By a comparison of these rates with local charges for the same works, a percentage of variation can be deduced which may be added to or deducted from the estimates per cubic foot of structure given in the schedule attached, without going into much detail, and the true local value of the works arrived at and estimated.

Works Built in Two Sections—If the complete plan of the new works or extensions be arranged for building in two sections, at two different periods, to suit a gradual outlay of capital, then, supposing the works when wholly finished to cost £3.54 per ton per year (as in the table annexed), then the first section will cost 66 per cent. of the ultimate cost of works; and until the completion of the scheme the capital cost per ton of coal carbonized per year will be at the rate of £4.72. This arises from the special arrangements of works which contemplate doubling the make at an early period of time, and which have about them many works performed on account of future operations.

Estimates.—The valuations which I here give in the schedule are made upon the assumption that the new gas works or extensions will be of a magnitude equal to that shown on the plan attached hereto, and which is capable of supplying, with certainty and safety, 5 million cubic feet of gas, and carbonizing 500 tons of coal per diem. I present the ideal plan with the paper to explain the arrangement of gas works generally, and not with a view to its being the only perfect arrangement for gas works. Some other plans would do as well to work out the factors of this address. You can take the plan "with a grain of salt" added from your own experiences, to make it suit individual fancies and predilections. Supposing the works to be carried out were of smaller caliber than the one before us, then, to arrive at their cost, I should merely add 2½ per cent. to the values given for every million cubic feet, or 100 tons of coal carbonized per diem, that they are less in gas power than the example furnished. In the arrangement of their gas works some engineers may like to play upon round figures, and would prefer for the several details multiples of the figures 5 and 10, thus: Retort house, 500; condenser, 5; scrubbers, 10; boiler and exhaustor houses, 10 each; meter house, 20; purifying house and lime and oxide sheds, 250; purifiers, 10 to 15; gasholder tanks, 500; gasholders, 1,000; tar and liquor tanks, 10 to 15; and workshops and offices, 150. They would then take the cubic feet of structural internal capacity per 1,000 cubic feet per diem of gas made in December, and, pricing out these at their respective rates, get the value of the works. This suits well for parliamentary purposes, and is fairly correct.

Position of Works.—The gas works, if possible, should be situated well away from the center of population, wherever a new site is necessary; and they should be in railway touch of the outside world and collieries, so as to avoid any necessity for excessive storage of coal in the retort house, with its consequent deterioration, beyond the 14 December days, or 21 days' average consumption. Cast iron pipes are cheap enough at the present time, and any convenient pressure up to about 18 inches can be insured on a long leading main from the works to the heart of a district by means of an auxiliary exhaustor at the outlet of the gasholders. The loss of illuminating power in the gas from long runs in mains may be disregarded where there is a good volume of gas delivered daily. It only amounts to 1-20th of a candle for each mile of pipe. With large volumes of gas and large pipes well under the ground, this almost disappears, and the light is less wasted than with the system of daily storage in a gasholder exposed to all sorts of weathers.

Working Expenses of Gas Works.—Having now given you thus much from my notebooks, experience, and observation as to the normal proportions and cost of soundly-constructed gas works, rated at per ton of coals carbonized, for examples where the engineer has anything like a free hand, or *carte blanche* given to him, we can arrive at the amount to be paid as a reasonable dividend per 1,000 cubic feet of gas sold to the consumer. By returns of gas works, old and new, most of them encumbered with used-up plant and structures, and "loaded" or "watered" capital not written off, the interest paid per 1,000 cubic feet of gas sold

is somewhere between 5d. at busy Manchester and 2s. at classical Harrow. But supposing the structural works to cost as before detailed, then 4½d. per thousand cubic feet of gas sold would be all that was required to pay 5 per cent. interest on the capital expenditure. The capitals of the various gas companies run from about £2.4 to over £50 per ton of coal per year. The working expenses, less cost of coals, which vary much at different places, need never exceed 10s. per ton of coals carbonized, or about 1s. per 1,000 cubic feet of gas at the consumers' meters; instead of which one finds they reach from 8s. 3d. per ton at Newcastle-upon-Tyne to 18s. at Harrow. The working expenses of a concern per ton (less coals) is the most crucial test by which to compare the operations of different gas works, as labor charges are tolerably uniform throughout the country; but coal prices vary as much as from 6s. to 18s. per ton in the retort house. And yet the management of some gas works must be at fault; for we find that the charges for labor, purification, and maintenance of works, including distribution, varies in different establishments from 6s. 8d. at Newcastle-upon-Tyne to 10s. 2d. in the case of the Gas Light and Coke Company, and up to 12s. per ton elsewhere. The supervision of the labor departments at gas works should be more keen. The manager need not spend so much of his time in the laboratory. There are good, kind, and well-educated gentlemen in charge of many gas works who do not like to cope with the "loafing" labor which requires weeding out. The time-sheets want a little of the laboratory system of analysis applied to them. Frequently the grains and volumes of the several gases are delicately sifted out and recorded in the laboratory; whereas outside in the yard and on the works the golden sovereigns are running away through the wide-mesh sieve of shuffling and dawdling labor. We cannot, however, all of us be all-round men and keen observers in our several positions of life, as well as scientists, test-tube shakers, and geniuses; but yet we are all expected in this advanced age of board schools to take off our hats to the scientist and retire to a back seat to observe his evolutions and pyrotechnics.

The Price of Gas in the Future.—From all future extensions and new works we must endeavor to supply and sell gas to the public at the lowest possible cost, to ward off competition from all sources, petroleum or otherwise; and for this purpose when coals can be delivered into the retort house at from 10s. to 12s. per ton, with residuals only producing about half the cost of coals, to sell the best 16-candle gas to the consumer at a price not exceeding 2s. per 1,000 cubic feet, including meters and external services. Thus: 1s. working expenses, 4½d. interest, and 7½d. coals, less residuals—in all, 2s. per 1,000 feet. This would then lift the gas stocks on the money market to a selling price of £100 for every £4 5s. of dividend, as with the leading railway stocks. Some gas experts assert, and they are not far from the mark, that if dividends of 4 or 5 per cent. were paid on gas stock instead of 12 and upward, gas might be sold to the consumer at 1s. 6d. per 1,000 feet in most of the large towns. I have an instance before me of a gas works which carbonizes, in round figures, 90,000 tons of coals per year; pays 9s. per ton for its coals in the retort house; the total working expenses (less coals), 9s. per ton; sells residuals at half the price of coals (like the Gas Light and Coke Company), leaving the latter at the net cost of 4s. 6d. per ton; and the net cost of gas, without interest, at the consumers' meters is 1s. 3d. per 1,000 cubic feet. The gas, however, is sold at 2s. 4d. per 1,000 cubic feet, the remainder going for interest and reserve fund. Nearly 10,000 cubic feet per ton are sold. In these works the structural value would not exceed one-half the capital recorded upon the books of the undertaking. Fancy a profit of 87 per cent. on the manufacturing cost of the vended article for dividend. Let us turn over a new leaf, and calmly await the future and fate. Let us do the best we can for the public, and not give the slightest cause for gas companies being called, as they have been, "Gas Trust Robbers," who must be thrown flat on their backs by competition.

I have laid as much as I can before you on this subject, and I have made it as practical as I can—from actual data. If any of you have had any difficulty in understanding any of the items, I shall be pleased to answer all questions which may be put.

Turning the Tables.

Under the heading of "The Gas Man's Joke," the Cincinnati (Ohio) *Telegram* recently published the following:

Some time ago a gentleman calling himself a gas meter expert arrived in Cincinnati from Chicago. He began operations by announcing himself a life-long enemy of gas companies generally, because gas companies were all robbers; and he was prepared, he said, by the aid of a test machine which he carried with him, to detect all dishonest gas meters. His charge for testing meters was \$5 each, which sum, he plausibly explained, could be saved in one month's gas bill if the meter in use was

measuring more gas than was consumed. So it was natural that in a short time he should find himself overwhelmed with orders from people wanting their meters tested, who were morally sure that they were being robbed.

Now, as a matter of fact, gas meters are as apt to be wrong as they are to be right, and they are, moreover, just as apt to have a weakness for not measuring enough as they are for measuring too much. This simple proposition anyone who is at all familiar with the construction of meters of any kind will understand.

And so in this case, while the expert found that all whom he approached were satisfied they were paying for more gas than they consumed, he found, also, in his three months' sojourn, that of the meters tested there were more of them rusty and slow to work than the number which, from leakage or other cause, measured more gas than was really consumed. Over a thousand meters were tested by him during his short stay here netting him a handsome return, and as was his practice, merely as a matter of form (?) he kept a journal showing the readings of each test, with the per cent. figured out of the excess or shortage, where located, the consumer's name, etc.

Those meters found to be measuring too much gas were promptly reported by the unfortunate possessor to the Gas Company, with a demand that the meters be at once removed and accurate ones put in their places. This was how the Gas Company heard of the Chicagoan's presence, and it took but little investigation on their part to learn just what was going on. The Company was also impressed by the singularity of the fact that all the complaints coming in were concerning meters measuring too much gas; not a complaint of meters short in their measurement. So a note was sent to the Chicagoan by the Gas Company something to this effect:

"MY DEAR SIR:—When you have completed your work of testing the gas meters in the city, if you will call at the office of the Cincinnati Gas Light and Coke Company, I am warranted in assuring you the visit will result to your advantage."

This message was duly signed and forwarded to the expert's address, and in a few days, having completed his work, the expert called on the Gas Company. He informed the Company that he had tested something over 1,300 meters, and in reply to questions said he had kept an account of the readings of each one of them.

"We will pay you 50 cents for every name with the result of the tests," said President Hickenlooper.

"I'm your man," said the Chicagoan. "I'm in the business to make money, and the names are yours."

Then the real music began. It was found that there were 300 or 400 meters in use in the city that were measuring gas too slow, and men were at once sent out by the Company to replace them with new meters.

One of the funniest incidents was that of Moses Kahn, who keeps a misfit clothing establishment at Seventh and Vine streets.

"So hellup me gracious!" he said, to the Chicago expert when he went to test his meter, "dot Gas Gombany was robbin' me. Tey are a lot of public tieves."

When the expert, after testing his meter, told Mr. Kahn that it was measuring only 50 per cent. of the gas he was actually consuming, he patted the expert on the back and said:

"Don't say a verd, young man—don't say a verd. Tey are robbers."

So when the Gas Company's man called on Mr. Kahn with a new meter, Mr. Kahn said:

"Who said I vant my meter shanged?"

"The Gas Company," replied the meter man.

"De Gas Company, eh? Vel, my meter suits me. I make no gomblaint."

"But I am sent here to make the change," persisted the gas man.

"Vell, I don't vant it shanged. Don't you know someding ven a man don't make some gomblaint?"

"Sorry, sir; but I must do my work," said the gas man, starting to go into the cellar.

"Shtop, you!" excitedly cried Mr. Kahn; "vere you go—into my cellar! Public robbers and tieves! You lot of tammed robbers! You shange my meter if I don't like it."

And Mr. Kahn went on relieving himself to his heart's content respecting the robbing proprietors of gas companies, when the gas man was making a change of the meters. When the gas man returned he hailed him with:

"De man vot charged me \$5 vas a tammed rascal, too—a dirty shpy of de Gas Company. Dey are all robbers."

And there were lots of people who paid \$5 for the sake of seeing their meter taken out and replaced by one that measured enough gas.

SPECIAL ENGLISH CORRESPONDENCE.

COMMUNICATED BY NORTON H. HUMPHRYS.

SALISBURY, Nov. 10, 1887.

Sensational Gas Management.—Cheap Gas.—Purification in situ.—Tar Useless for Gas Making.—Gas for the Million.—Reduction in Price.

One would imagine that the history of a gas undertaking must necessarily be of a dry and musty sort, partaking of the nature of those Parliamentary papers which are issued for the delectation of members of that august assembly. Yet sometimes it is not wanting in romance—of a kind. An unexpected action on the part of the directorate is as entrancing, to the professional mind, as the "situations" which are so greatly favored by artists of fiction. It really appears as if the Gas Light and Coke Company, of London, desired to be sensational in a technical way. Only last September I was remarking upon the extraordinary manner in which their profits had jumped up during the last half year; and now comes a fresh surprise. On the 1st day of January, 1888, the price of gas is to be reduced to the extent of 6 cents per thousand cubic feet in the case of common gas, and 8 cents on the cannel gas. This will bring the price to ordinary consumers down to 66 cents per 1,000 cubic feet of common gas, and 82 cents per 1,000 cubic feet of cannel gas; the public lamps being supplied at a cheaper rate, viz., 52 cents and 64 cents respectively. The consumers, of course, are glad of the reduction, and so, strange to say, are the electricians. This is not a specimen of genuine disinterestedness. They welcome the change because it will render motive power of the gas engine kind cheaper. Such independent testimony as to the value of gas engines is very acceptable. The importance of this reduction is rendered more apparent when we look at the fact that the gas was already sold at a comparatively low rate. A 6 cent reduction would not look much, for instance, on the Paris price, which is more than \$1.50 per 1,000 cubic feet, but when applied to a 72-cent rate, it means one-twelfth part of the whole. It means to the Gas Light and Coke Company a diminution in gas rental to the extent of 8½ per cent., or about the sum necessary to pay the dividends; and when it is remembered that the shareholders do not expect any falling off in the amount of profit earned, we may well call this sort of financiering by the term of "sensational." I remember that in the time of the coal famine some gas companies pulled through by dint of much scheming and economy without raising the price of gas. In many cases the result was not, as might be expected, gratitude on the part of the consumers; but the amiable suggestion that very excessive profit must have been the rule before the famine, and as soon as coal had resumed its normal values a prompt demand for a reduction. In a similar manner large reductions are usually received with a certain amount of suspicion. The present case is no exception, for already there is some talk of an agitation for the abolition of meter rents.

This 8½ per cent. reduction, however, will afford interesting information for the use of the gas profession generally. Gas engineers have heard so much lately about "cheap gas" that the expression has almost the same effect upon them as the mention of the word "jubilee" on the ordinary British citizen. Not that the latter is disloyal, but he has heard so much about the jubilee festivities during the past few months that he is tired of it, just like a child that has eaten too much jam. Anyone making a joke about the jubilee is promptly ignored as an offensive character. And really there has been so much said and written about selling gas cheaply of late years that the subject grows wearisome. Here, however, is an experiment on a gigantic scale. The effect of this large reduction, as regards the gas supply in the district, will be carefully watched by those who advocate liberal concessions to consumers, and by those who do not; and, as is usually the case, both sides will select evidence from the results in support of their own views.

Mr. S. Penny has recently made an interesting communication to the *Journal of Gas Lighting*, on the subject of oxide purification *in situ*, by admitting a trifling proportion of air to the gas before purification. The objection hitherto felt against this process is the effect of the residual nitrogen on the illuminating power of the gas. Mr. Penny claims that if the air is admitted at the hydraulic, while the gas is warm, a certain amount of carbureting action takes place; so that, practically, the quality of the gas does not suffer. He uses, on the average, two per cent. of air, which leaves about 1½ per cent. of nitrogen mixed with the gas, and claims to have introduced as much as three per cent. of air at the hydraulic without any deleterious effect on the illuminating power.

It would be interesting to carry these experiments further and ascertain how much loading with air the gas would stand. Mr. Penny also claims, as an advantage in connection with the air system, that the

chemical action in the purifiers causes a slight increase of temperature, so that the gas leaves the purifiers some 15° to 20° higher than it enters. This he considers improves the illuminating power of the gas. In severe weather it would certainly be of benefit, for the illuminating power often suffers if the temperature of the purifier falls, say, to freezing point. But the question of introducing diluents in any form into gas is one that must be carefully considered on all sides. The experiments made by various observers agree in showing that their depreciatory effect is much more marked in the case of flat flames and small burners than with the standard burner. Mr. J. T. Sheard found that a proportion of carbonic acid which only influenced the illuminating value of the gas when used through a standard Argand burner to the extent of three per cent. reduced it some ten per cent. when the Argand was replaced by a flat flame burner. My own opinion is that a gas free from diluents burns with a whiter and better looking flame, especially in small burners, than another of equal illuminating value, but containing perhaps two or three per cent. of nitrogen, carbonic acid, etc.; and therefore I always prefer to purify the gas by means of lime rather than to bring up the illuminating power with cannel. I have repeatedly turned off the lime purifier and used more cannel so as to keep the photometrical value from falling off; but have always found that complaints are made to the effect that the gas is not so bright as usual. Remembering that nine-tenths of the gas is burnt through flat-flame burners, Mr. Sheard's results serve to explain this experience.

M. Grebel, Engineer at the Guise gas works (France), has lately been trying some experiments with tar as a gas making material, according to a plan proposed by M. Eichelbrenner. This system consists of mixing the tar with a considerable quantity of solid materials such as lime, sawdust or small coke, to enable it to be charged into the retorts in the same way as coal. The mixture is used in the retort house instead of that substance in the proportion of about 10 per cent. The plan does not answer, because the gas evolved from the mixture is so inferior in lighting qualities as to be practically non-luminous, probably by reason of a large quantity of carbonic acid being evolved from the sawdust. Two kinds of mixtures were used, the first consisting of equal parts by weight of tar and whitewood sawdust with 10 per cent. of lime, and the second of two parts tar to five parts coke dust. The gas evolved from the coke dust mixture was rather better in quality, but still very inferior. The yield was very low as regards quantity, and the cost of the mixture, including extraneous ingredients and labor, was nearly as much as that of coal. M. Grebel considers that tar is far more valuable as a fuel than as a carbonizing material. He uses it under the retort fires, and finds that ten parts of tar are as good as seventeen parts of coke. Tar has been repeatedly tried in ordinary retorts, usually by admixture with small coal, but with no success.

An interesting attempt is to be made at Denton, in the way of competing with cheap petroleum. Mr. J. M. Veevers, the Manager of the gas works (which belong to the local authorities), was instructed some time since to prepare a report for his Committee on the subject of the competition to which coal gas was subject by other lighting agents in the district supplied by them. In his report Mr Veevers states that the use of oil lamps is extending amongst the poorer classes, because the lamps are cheap and the oil can be bought in small quantities; whereas with gas the fittings are costly, there is a meter rent to pay, and the bill is presented at long intervals when it has attained comparatively large proportions. In order to meet these objections he proposes to abolish meter rents, and to collect a small sum weekly, say, 7 cents in summer, and 13 cents in winter, from those who are placed on the weekly supply system. The meters are taken, and the accounts made out quarterly, as usual, and the weekly payment is placed to the credit of the account. If any balance is found to be due from the consumer it is collected as an extra, or if, on the other hand, the Company have received more than is due, the balance is returned, or carried forward, as may be desired. The Committee have resolved to make a trial of the suggestion. It will be observed that it does not touch upon the cost of gas fittings. Most of the houses in the district are provided with these furnishings by the owners, so it was considered that this point did not call for attention at present. For sometime past the system of weekly payments has been in use amongst the operatives in Manchester, and I am told that the South Metropolitan Gas Company are trying an experiment in this direction. I also know that there is at least one gas undertaking who have made a practice of letting out on hire not only gas cooking stoves, but also gaseliers and fittings of all kinds, for many years past. At present gas consumption shows a satisfactory increase without resorting to any of these aids, and so long as this is the case they are not likely to be adopted to any great extent; notwithstanding the fervent exhortations of those who anticipate a day of brisk competition to be at hand. Once, however, let

two or three undertakings find their consumption falling off and the whole will take fright. These systems will then come in with a rush. There is much truth in the proverb, "make hay whilst the sun shines," and it behooves the managers of gas undertakings to make their positions as secure as possible whilst they are undisputed.

Several reductions in price are announced in different parts of the country. At Plymouth, where the charge for gas is already at the low figure of 44 cents, a reduction of two cents has been made, bringing it down to 42 cents, the lowest price at which gas is retailed in England. The Ventnor Gas Company are rapidly improving in circumstances, having reduced their price no less than 32 cents within the last four years. At Neath a similar policy has been followed. At Halifax the present price is 52 cents in the borough, and 76 cents on the outskirts; an all-round reduction of 4 cents per 1,000 is to be made, and large consumers will be allowed discounts after the rate of 8½, 10, or 12½ per cent. according to the quantity consumed. The Redcar Gas Company announce a reduction of 12 cents per 1,000 cubic feet, with a ten per cent. discount for prompt payment, and they are also introducing the system of differential prices, by allowing an additional discount of 25 per cent. on all gas used for cooking or for motive power. This system, by-the-way, has recently been adopted at Berlin, where a discount of 20 per cent. is now allowed on all gas used for other than lighting purposes. At Seaford a reduction of 10 cents has been made. The Huddersfield Corporation have decided to offer gas for cooking, motive power or technical purposes at 48 cents, an important reduction on the current rate. These are simply a few instances that come to mind at the moment, and they serve to show that the gas industry is advancing, also to illustrate the ignorance of those who assert that gas engineers are satisfied to trot along in the old ruts. How could such large reductions be made in the absence of important improvements at the works? Increase in consumption and cheap materials account for them in some degree, but are by no means sufficient to cover the whole.

ITEMS OF INTEREST FROM VARIOUS LOCALITIES.

ANNUAL ELECTION, RAHWAY, N. J.—The stockholders of the Rahway Gas Light Company have chosen Messrs. J. R. Shotwell, Wm. Mershon, W. B. Houston, W. C. Squier, J. Osborne and Jas. Vanderhoven to act as a Board of Directors during the ensuing year. Mr. Shotwell acts as President and Treasurer, Mr. Houston filling the triple position of Secretary, Engineer and Supt. The careful management of those in charge of the Company's fortunes is rapidly advancing its financial standing.

A LINE FROM PAWTUCKET, R. I.—Brother Stiness evidently means to keep the Pawtucket Gas Company's plant up to the highest standard, for he has empowered the Jarvis Engineering Company to add thereto an Armington & Sims' engine and two tubular boilers, to be set in accordance with the Jarvis Company's plan of boiler setting, which, as our readers are aware, permits of the economical and satisfactory use of coke and coke screenings for fuel. The Pawtucket gas shareholders have abundant reason for satisfaction over the way in which their property is conserved.

THE BRADDOCK (PA.) COMPANY ONCE MORE IN LINE.—The dollar rate for gas is no longer a stranger to the States; in fact, '87 has conclusively shown that the long-looked-for figure is about to reveal itself frequently within the coming twelvemonth. To this, of course, we can only say the oftener the better; and perhaps we may soon take up the hope that another shilling will be clipped from the hitherto long-wished-for "dollar goal." Certainly, it is going to be much harder work to get down to "seven shilling gas" from the dollar notch than it was, say, to recede from \$1.25 to \$1; but the American gas maker is bound to achieve that which he starts out to gain. We venture to hint at seven-shilling gas on account of the action lately taken by the owners of the Braddock Gas Light Company, whose territory (although most favorably situated for the cheap manufacture of illuminating gas) is but a comparatively small one—that is, in respect of population, wealth, and so on. However, the proprietors have taken the bull by the horns, and the following schedule shows whether they mean business or not:

Monthly Consumption.	Net rate per M.
Under 3,000 cubic feet.....	\$1.20
3,000 to 10,000 ".....	1.10
Over 10,000 ".....	1.00

These concessions operate where payment of accounts is made on or before the 10th day from presentation of bills, and those failing to settle within the prescribed time will incur a penalty of 10 per cent. for their

delinquency. The prior rates were the following: Under 3,000 cu. ft., \$1.40; over 3,000 cu. ft., \$1.20. We are indebted to Mr. James S. Kuhn, President of the Company, for the details above given, and we cannot forbear to here quote the following lines from his courteous letter to us on the subject: "Since we have owned the Braddock gas works we have made frequent reductions in the selling price of gas, and, as you will notice, our last rate brings us down to the lowest price at which gas is sold in Pittsburgh or Allegheny City. Such a low figure in a town of the size of Braddock is very unusual; but our Company has always adhered to the policy of selling gas as cheaply as possible. The consumption of gas in Braddock is constantly growing, hence with the large gain in consumers we have been enabled to operate the plant more economically, and have given our patrons the benefit of such gains by our last reduction in the selling price. Our Company has also decided to put in an electric light plant at Braddock, as a number of the storekeepers desire to use that method of illuminating their places of business."

Mr. Napoleon Aubin is the official Gas Inspector for the Dominion of Canada. His headquarters are located in Montreal.

PUBLIC LIGHTING, MERIDIAN, MISS.—Through the efforts of Secretary Robinson, of the Meridian Gas Light Company, the authorities of that city recently awarded a contract for the public lighting to the Company. The agreement calls for the maintenance of 100 gas lamps, lights to burn every night and all night, to be paid for at the rate of \$3 per lamp per month, the contract to run for five years from Jan. 1, 1888. The representatives of several electric systems tried to convince the City Fathers of the economy and efficacy of electric lighting, but without avail. Secretary Robinson proclaimed to the authorities his willingness to establish an electric lighting plant, if it were deemed best to change the system of public lighting.

THE KERR MURRAY COMPANY'S LIST.—President Cressler writes that his Company, in addition to the complete 8-inch works ordered by the Charlottesville (Va.) Gas Company, has the following work underway: A set of 5 ft. by 5 ft. purifiers, and other extensions as well, for the Paris (Texas) Gas and Electric Light Company; an iron roof for retort house, boiler, etc., for the Northwestern Gas Light and Coke Company, Evanston, Ills.; and 14 benches of sixes, with self-sealing mouthpieces and anti-sealing dip pipes for the Memphis (Tenn.) Gas Light Company.

A HINT FROM APPLETON, WIS.—Under the management of Mr. H. T. Harcastle, formerly in the employ of the Equitable (Chicago, Ills.) Company, the Appleton Gas Light Company's sendout has been largely augmented. This, too, despite the fact that the local plant maintained by the Edison Company is intended to operate in the nature of a standing advertisement, for the greater part of Wisconsin, of the excellencies of the wizard's pet lighting method.

THE San Rafael (Cal.) Gas Company has determined to add an electric light annex to its present plant. It is expected to complete the work of construction, etc., by Jan. 15.

SEND IN YOUR NAMES.—On July 1 the Committee on Publication, Franklin Institute, issued a circular conveying the information that they contemplated the publication of an index of authors and subject-matter contained in the first 110 volumes of the Institute *Journal*, provided a sufficient number of subscriptions (at \$5 each) could be obtained to cover the cost of the work. The value of the proposed index would be very great to those who possess any considerable number of the volumes in question, and we are not so sure but that it would be equally great to newspaper writers, patent attorneys, specialists, etc. Certainly it would save these latter much time when desirous of hunting up information of especial value to them at the moment; for the *Journal* contains copious and, best of all, reliable mention of things connected with the development of science and the mechanic arts in this country during the last 61 years. We regret, however, to say it has been found necessary to issue a second circular in connection with the project, but hope to add shortly that the requisite guarantee has been obtained. Many a gas man would find in this Index a valuable addition to his library. Subscriptions should be sent to Mr. H. L. Heyl, Actuary, or to Dr. Wm. H. Wahl, Secretary of the Institute.

PUBLIC LIGHTING, ALTON, ILLS.—The City Council has awarded a contract for the public lighting to the Alton Gas Light and Coke Company, a mixed system to be followed. Under the agreement the Gas Company will maintain 20 arc lights, in addition to the full complement

of gas lamps hitherto employed. The arcs are to cost the city \$100 each per annum.

TURNED ON.—The plant of the St. Clair (Mich.) Gas Light and Fuel Company having been completed, St. Clair's residents are now basking in the light of the present. St. Clair is located at the mouth of Pine river, is 12 miles south of Port Huron, and 48 miles (by water) northeast of Detroit.

We understand that construction work is to begin forthwith on the gas and electric light plant intended for the lighting of Gainesville, Fla. This place is the capital seat of Alachua county, being located about midway of Jacksonville and Cedar Keys.

INEXPEDIENT.—A Committee appointed by the Wakefield (Mass.) authorities to inquire whether it would be prudent to employ electricity as a public lighting agent has reported that "it would be inexpedient to make the change from gas." Reason, the expense would be about twice as great—quite sufficient, too.

CAUGHT.—Some time ago two clever sneak thieves stole about \$500 from the office of the Roxbury (Mass.) Gas Light Company, the robbery being effected in business hours, and with the greatest coolness possible. Two of the "operators," much to the surprise of those who suffered, have been enmeshed by the police. They—the "operators"—are stars in the "crooked" firmament, and answer respectively to the names of George Carson and Rufe Miner. They were arrested in Chicago, Ills., on the 15th ult. Chief Inspector Hanscom, of Boston, must be a pretty clever detective, for it was chiefly through his sagacity that the purloiners were "pinched," to use the Vidocq vernacular.

OBITUARY NOTE.—We are pained to say that the fraternity has lost a valued member in the death of Dr. W. R. Tomkins, who for years was prominently identified with the best interests of the city of Gallatin, Tenn. While the Doctor never came publicly before the recognition of the fraternity, he nevertheless was held in warm esteem by the gas men of the South and Southwest; but his demise will be especially felt by the proprietors of the Gallatin Gas Light Company, whose President he had been. *Vale!*

HIS SUCCESSOR.—The death of President Tomkins necessitated the holding of a special meeting of the stockholders of the Gallatin Gas Light Company. The ballot resulted as follows: The Directorate vacancy was filled by the election of Col. James Alexander, then the Board organized by selecting Capt. Geo. Harsh to the Presidency, D. K. Anderson being chosen Secretary, the Treasurership falling to T. H. King.

SOLD.—We hear that Mr. John Q. Brown, of Sacramento, Cal., has sold out his interest in the Woodland gas works (same State) to a local syndicate. The purchasers paid \$12,500 for the Brown interest; and as that means control of the Company, we think they got a bargain, and a good one.

A LIVELY LIST OF "WESTERN WAIFS."—Supt. Feeney, of the Lexington (Ky.) Gas Company, reports satisfactory business and pleasant prospects. To keep pace with the growth of the city the main mileage has been extended, the City Council having recently ordered the placing of new lines over which a number of public lamps will be located.—The Hamilton (O.) Gas and Fuel Company some time since applied to the City Fathers for permission to lay mains and manufacture gas. The request was submitted to the people, who, on Nov. 8, indorsed the project, giving thereto a majority of 1,226. The same Company is operating at Bellevue, Ky.—The old Hamilton (O.) Gas Company hoped to have its electric lighting plant in operation on the 1st inst. Some delay occurred on the part of those who agreed to furnish the apparatus, but Supt. Hensley, with his characteristic energy, has made things lively around him since the receipt of the machinery. He does not seem much alarmed at the prospect of a competing gas company.—Said Manager Fullager, of the Georgetown (Ky.) Gas Company, to your correspondent: "Our business has been unusually good this year, and the outlook is encouraging. Our consumers' list has increased 50 per cent. within the past two years, and we are, with becoming regularity, adding to the number. We made many needed extensions during the summer, and, among other improvements, built two new benches of 3's. Now we are ready for the winter's work." Mr. Fullager has had erected for himself one of the handsomest homes in Georgetown. It was completed in time to enable him to eat therein his Thanksgiving turkey.—Energetic Superintendent Shea, of the Frankfort (Ky.) Gas Company, was discovered by your reporter crowded with work—endeavoring to have his affairs in complete order for the winter's campaign. The manufac-

turing apparatus (water gas) having received a thorough overhauling, is now a model specimen. Many new services have been run and old ones renewed.—The scarcity of coal in the country tributary to and dependent upon Cincinnati and the Ohio river for its supply is causing a world of trouble to the gas companies. Not for months has a barge load of coal passed down the river, the Ohio being at a lower stage, and for a longer period, than the "oldest inhabitant" can recall. The railroads west of Pittsburgh find it impossible to obtain enough cars to supply the demands made on them. Their roads are covered with extra coal trains for the West, and trains of "empties" on the way back to the mines. To add to the distress, well-grounded fear of a "freeze-up" is entertained—a cold spell, in the present condition of the river, is sure to close it.—Ald. Hodgden, of Lake View (a Chicago suburb), Chairman of the Committee on Street Lighting, has recommended to the Council the building of gas works by the city. This honorable gentleman says the necessary plant, including 15 miles of mains, can be secured at an outlay of \$96,000, and that gas can be sold at 50 cents per 1,000 cu. ft. Action on the matter has been deferred.—The Toledo (O.) Gas Company has run natural gas into its retort house, and will use it for fuel under the benches.—The recent cold snap affected the pressure and supply conditions of the natural gas mains at Lima, O., and caused considerable dissatisfaction among the residents who depended solely upon gas for fuel. The happening boomed the Lima coal market.—The latest news from the Sandusky (O.) natural gas well advises that the drills have penetrated 150 feet into the Trenton rock, and yet no hopeful indications. W. H. Murphy, of Cleveland, has asked permission of the Council to bring in the gas from the Oak Harbor—about 24 miles east by south of Toledo—wells. His request will be granted.—Heretofore it has cost something like \$3,000 per annum to light the streets of Glendale (O.) with gas. Bids for a 5-year contract have just been opened, and the probabilities are that an attempt at gasoline lighting will be made—a company having agreed to light with that odorous agent at about one-half the former cost.

DIAPHRAGM.

THE OMAHA (NEB.) EXPLOSION.—The explosion that occurred last month in the generating house of the Omaha Gas Manufacturing Company's plant occasioned much inconvenience to the inhabitants. Luckily the pecuniary loss to the proprietors was not of a serious nature, although it might easily have been otherwise.

MORE BENEFACTORS.—The Fire Committee of the San Francisco (Cal.) Board of Supervisors have been appealed to by the projectors of the Standard Gas Light and Fuel Company for permission to construct a manufacturing plant on the site of the old Selby Smelting Works, which is located within the fire limits of the city. J. D. Boyer, who appears to be Secretary of the Company, the latter seeming to be a branch of the ex-high pressure concern, which, in time(?) is to dot Manhattan Island over with "storage tanks and gas works"—spoke in favor of the plan, and guaranteed, if the coveted permission were granted, to eventually furnish gas at a price at least 50 cents per thousand lower than that now charged in San Francisco. The existing companies will "eventually" do the same thing, if left to themselves; and it will be only postponing the "eventuality" if permission be now accorded the petitioners to enter San Francisco's artificial lighting field. The Committee is "investigating" the merits of the application.

The Massachusetts Gas Commission has authorized the Lawrence Gas Company to engage in the business of the manufacture and distribution of electricity.

We understand that the Big Rapids (Mich.) Gas Light Company will make an important reduction in gas rates on Jan. 1st.

THE SALE OF NATURAL GAS IN THE CITY OF MORMONDOM.—A correspondent sends the following: "The Salt Lake City (Utah) Gas Company has applied to the City Council for a grant of the sole franchise for the introduction and sale of natural gas in the city. The application was accompanied by a draft of an ordinance covering the conditions of right, etc. It is proposed that the franchise run for 10 years; that the Company be not required to lay pipes in the city until such time as the natural gas shall have been conveyed to the boundaries thereof, if the gas be found at a distance from the city limits; and that the Company shall pay to the city for the said franchise 15 per cent., monthly, of all revenues or amounts received from the sale and use of said natural gas, and, in addition, annually pay into the city all net profits realized on such sales and uses in excess of 7 per cent. upon the amount of money actually invested by said Company. The petition and ordinance were referred to the Committee on Streets and Alleys."

The Salem (Mass.) Gas Light Company is putting in a new 10-inch main on Boston street, in order to cope with the greatly increased demand for gas in the upper sections of the city. This tells whether or not Brother Moore's folks are satisfied with the outlook. To us it looks as if they were.

The Conshohocken (Pa.) Gas Company is putting in an electric light plant, the contract for which was awarded last week.

AN INTERESTING LEGAL DECISION.—On November 21 word was received that the Supreme Court of West Va., in determining the case of the proprietors of the Parkersburg Gas Company vs. the local electric light company, had decided in favor of the latter. The history of the case is about like this: A number of years ago the Parkersburg City Council granted the Gas Company the exclusive right to use the streets and alleys for the purpose of supplying through them, by appropriate means, the illuminating agent for the lighting of the city. Some years thereafter an electric light company was formed, whereupon the reigning Council granted the electricians the privilege of lighting the city. The latter put up poles and strung wires, but just prior to the starting of the plant the Gas Company sued for an injunction restraining the Council from carrying out its pledge and estopping the electricians from supplying light either to the city or to private consumers. The case was brought in the State Circuit Court, and Judge Jackson, before whom the matter was argued, decided that the contract entered into by the city with the Gas Company was binding—in so far as the public lighting was concerned, and that *no other* company could light the city until that contract expired by limitation. He, however, also ruled that the electricians could proceed with the work of lighting private buildings. Neither company was satisfied with Judge Jackson's decision, and the case was taken to the Supreme Court of the State, whose magnates have asserted that the contract made with the Gas Company is not of a nature to preclude the Council from contracting with the electric company for either public or private lighting. The Court also denies the right of any City Council in West Virginia to grant an exclusive contract of the nature under consideration to any company. The "exclusive" pledge given to the Parkersburg Gas Company would lapse by limitation, in 1898. It is curious to note how frequently great minds—particularly those that are paid for construing the law—differ when pondering over cases whose legal aspects are to all intents and purposes identical. We are, however, disposed to assert that if this case were carried to the U. S. Supreme Court, the verdict of that tribunal would be in direct conflict with the one just formulated by the Dogberrys of West Virginia's Supreme Court.

The Corsicana (Texas) gas plant, which has been shut down for some time, has been fired up. I. Barry is in charge.

KILLED—Jno. Barnicle, employed as a lamp trimmer by the Burlington (Iowa) Electric Light and Power Company, while in the performance of his duty, received a fatal electric shock.

The Springfield (Mass.) Gas Light Company's sendout for last October exceeded that of the corresponding month in '86 by one million cu. ft.

It will cost about \$140,000 to light the streets of Washington (D. C.) in '88, of which sum \$30,000 will be expended in arc lighting. Two hundred and fifty gas lamps are to be put up, bringing the total of these up to 4,767.

F. B. Ainger and others have filed articles incorporating the Sturgis (Mich.) Gas and Electric Light Company. Capital, \$120,000. Sturgis is a village of St. Joseph county, and is 24 miles west by southwest of Coldwater. Population, about 3,200.

We understand that the works of the Fremont (Ohio) Gas Company are being adapted to meet the requirements of the McKay-Critchlow system of manufacture. The proprietors expect, in consequence of the new departure, to put the Fremont selling rate at \$1 per thousand in the near future.

WHAT THE WATERHOUSE ELECTRIC MANUF'G COMPANY IS DOING.—The proprietors of the Waterhouse Company, of Hartford, Conn., are not making any great noise over their operations, but their system of arc and incandescent lighting nevertheless rapidly gains favor. Not long since the Otto Gas Engine Company tested in a practical way what could be achieved by the Waterhouse plan of arc lighting, using an Otto engine to drive the dynamos. The Otto folks returned a most satisfactory report at the conclusion of the experiment, making especial mention

of the steadiness of the illumination obtained. Best of all, the regularity was not secured at the expense of economy, since we are told that the number of lights maintained from the duty of the engine exceeded, by about 25 per cent., those obtained under like circumstances when other arc systems were being experimented with at the Ottoshops. The Waterhouse plant—of the $\frac{3}{4}$ -arc type, for $8\frac{1}{2}$ ampere current, and driven by a 25-horse power Otto engine—recently put in operation by the Washington (Ind.) Gas Light Company, is giving unequivocal satisfaction to its purchasers and the people of that city, unless the local newspapers are wrong in their conclusions. This is what the *Washington Gazette* thinks about it: "Our system of electric street lighting is a pronounced success, and meets with favorable comment from all the traveling men who visit our city. Several of these have expressed their opinion on the topic to our reporter, and they all agreed in saying our Washington light is superior to the best electric street lights seen by them in other places. It is steadier, clearer and brighter than those produced by other systems." The Waterhouse Company claims that its $\frac{3}{4}$ -light can be produced at an expenditure of power similar to that required for maintaining standard $\frac{3}{4}$ -arcs of other systems; further, the illuminating effect from the Waterhouse $\frac{3}{4}$ -arc is 33 per cent. greater than that given by the standard half specimen. Orders now in hand for Waterhouse plants include one from the Grass Valley (Cal.) Gas Company, and a 500-arc capacity specimen for Baltimore, Md. The proprietors of the Fresno (Cal.) Gas Company thus record themselves: "During the six months' test to which we have subjected the plant we have had every opportunity for judging of the merits of the Waterhouse system of arc lighting, and do not hesitate to recommend it." In consequence of the demands made upon their resources the Waterhouse folks have been obliged to double the manufacturing capacity of their factories, and are now ready to promptly answer the calls of their patrons.

DISMISSED.—Some of the opponents of the Louisville (Ky.) Gas Light Company, whose scent for fraud was vastly more acute than was their ability or desire to comprehend in the open actions of reputable and fair-dealing fellow townsmen anything that differed from the usual business course of the latter, charged Messrs. Jno. M. Atherton, Jacob Smyser and Henry Bishop with bribery during the last local election. Waxing strong in their indignant righteousness, the unbribed went before the last session of the Grand Jury, and, on information and belief—no doubt the latter element entered largely into the information—charged the before-mentioned with "feloniously appropriating the funds of the Louisville Gas Company to their own use and to the use of others, with intent to cheat said Company and the stockholders thereof." Continuing, the righteous concluded, "They did, without the authority of the President and Directors of said corporation, unlawfully, wilfully, fraudulently and feloniously appropriate a large sum, to wit, \$10,000, the property and funds of the Louisville Gas Company and the stockholders thereof, to their own use, and to the use of other persons unknown to us, with the fraudulent intent to cheat and defraud the said corporation." The Grand Jury, having listened to the fund of information and belief in the possession of the righteous, promptly bundled them out of court, to nurse in impotent wrath the fancies of their diseased imaginations.

HOPKINSVILLE, KY., had a sensation the other day when Walter Hawley, the 11-year-old son of J. F. Hawley, Manager of the Hopkinsville gas works, ignited a match on the iron tank used for storing oil. The lad intended to light a cigarette, but paid dearly for his thoughtlessness, since the tank exploded, inflicting injuries on the unfortunate youth that caused his death.

WILL THEY GO BACK TO IT.—The Baltimoreans having become so habituated to 50 cent gas during the continuance of the lately terminated war of rates, do not take kindly to the new schedule, although the latter is far from being an oppressive one. The authorities also share in the feeling of discontent, and possibly sober old Baltimore is about to go to the ancient practice in vogue—that of putting out (rather, not lighting them at all) the street gas lamps when pale Luna is down on the tables to remove her veil. At any rate a correspondent, who usually knows whereof he speaks, says that the change is likely to be made, giving in support of that view the following reason: "The Mayor has had a conference with F. W. King, Gen. Supt. of Lamps, relative to the cost of lighting the gas lamps all night and on nights or parts of the same when the moon is in her dark phase. The Mayor says that his predecessor very properly ordered the lamps to be burned all night when the price of gas was 50 cents per thousand, but now that it has been advanced to \$1.50 he thinks that economy should be practiced. The Mayor claims that Supt. King figures out an annual saving of \$40,000 to the city if the moon-table system is adopted."

CONSOLIDATED.—Some months ago we noted that a war of gas rates had been inaugurated at Poughkeepsie, N. Y. The fight is now, however, a thing of the past, the old Poughkeepsie Company having purchased the plant of its rival, the Citizens Company, established years ago by Mr. A. L. Allen. We understand that both plants will be kept in operation, at least through the winter. President Atwater evidently is a keen business man, and knows how to cleverly accomplish a good stroke of commercial policy. Mr. Allen, of whom it may be said that he always was an honest opponent, is hereafter to occupy the position of advisory agent to the consolidated company.

AN explosion occurred in the cellar of the purifying house of the Frederick City (Md.) Gas Company on the morning of Nov. 19. The damage was slight.

BENJ. FREIDBURG has received a franchise guaranteeing him the exclusive right to construct, maintain, and operate an electric light works in Kansas City, Kansas.

CHEAPER GAS FOR BIRMINGHAM, CONN.—Mr. Nettleton, General Manager of the Derby Gas Light Company, of Birmingham, having shown the fraternity (by means of his paper on residual products, read at the last meeting of the American Gas Light Association) how to handle and dispose of such products, now comes forward with a practical reminder of the benefit that accrues from careful working. On the first of November his Company instituted a selling rate of \$1.60 per 1,000. Those who during the twelvemonth will have paid to the Company \$500 for gas are to receive a rebate of 10 cents per 1,000, an annual payment of \$1,000 securing a rebate of 20 cents per M. Large users consequently obtain their gas at \$1.50 or \$1.40, according to quantity annually used. The Derby Company leases Lungren burners at a monthly rental of 25 cents each.

Mr. Emil Lenz was united in marriage, on the 29th ult., to Miss Liddy Sonntag. The ceremony was performed in the German Lutheran Church, Stapleton, S. I.

THE Mansfield Gas Lighting and Heating Company will soon be in the field for public favor at Mansfield, Mass. This place is 24 miles south by west of Boston.

Frank Richardson, of the North Adams (Mass.) Gas Company, has been elected Treasurer of the United Zylonite Company. Good luck, Bro. Frank.

Notes from the West.

By RETORT.

Anna (Ills.) is to have an Edison electric lighting plant, providing the city authorities will contract for 200 lamps of 20-candle power each.

The Vandalia (Ills.) City Council recently passed an ordinance granting a 30-year franchise to Messrs. Geo. W. Brown and D. M. Clark, of that city, for laying mains and selling either natural or artificial gas to the residents. They propose to bore for the natural, failing to find which they will erect suitable works for manufacturing the artificial article.

Indianapolis, Ind., has for the past two weeks been engaged in a movement looking to the raising of \$500,000 by popular subscription, the purpose being the piping of natural gas to the city, the same to be furnished to consumers—particularly manufacturers—at cost. The canvass was vigorously prosecuted, and at a meeting, held on the 19th ult., announcement was made that the entire amount had been secured. The organization is known as the Consumers' Gas Trust, and operations will be begun at once. The movement is of a purely popular character, the number of subscribers exceeding 4,500. It is claimed that this Trust will be able to furnish natural gas at lower prices than in any other city in the country. The gas will be brought a distance varying from nine to twenty miles, and the organization of the Trust is such that perpetual competition is assured.

The recent annexation of Hyde Park to Chicago has given rise to some points of interest to the recently-formed Gas Trust. The Chicago press has been very bitter against the Trust ever since the price was raised from \$1 to \$1.25 per thousand, and in the advent of the Hyde Park Gas Company they claim to see the relief sought for. The Hyde Park Company manufactures gas under the Fahnehjelm process, and great stress is put upon the fact that gas is sold at 50 cents per thousand. Of course, to the press all gas is alike, and no mention is made of the comparative lighting values of entirely different gases. In this way advantage is taken of the public, who, upon reading the articles, conclude that the Fahnehjelm gas is identical with that furnished Chicago's gas consumers in general, therefore not noting any reason why gas should sell in one place for \$1 per thousand and 50 cents in the other, readily swell the cry of "thief and robber." Already the press is urging upon the public the importance and necessity of extending the powers of the Hyde Park Company, to enable the latter to lay pipes and distribute gas over the entire city. It is claimed that the Hyde Park Company is ready to enlarge its plant to meet the demand upon it. Another scheme urged with great vigor is that the city erect and operate its own plant; and a bill providing for this is now pending in the City Council. With all these various schemes in force the Chicago light question bids fair to be lively for the immediate future.



A. M. CALLENDER & CO.,
PROPRIETORS.

Editor—JOS. R. THOMAS, C.E.
Asst. Editor—T. J. CUNNINGHAM.
Manager—C. E. SANDERSON.

PUBLISHED ON THE 2ND AND 16TH OF EACH MONTH
At No. 42 Pine Street, New York.

This is a recognized official organ of—
LIGHT, HEAT, STEAM, WATER-SUPPLY,
VENTILATION, SANITARY IMPROVEMENT
AND GENERAL SCIENCE.

TERMS

SUBSCRIPTION—Three Dollars per annum, in advance.

AGENTS

NEW YORK—AMERICAN NEWS Co. 39 and 41 Chambers St.
BOSTON—S. M. PETTINGILL & Co., 6 State Street.
PHILADELPHIA—PRATT & Co., Corner 9th and Arch Streets.
England—C. W. HASTINGS, 22 Buckingham St., London, W.C.
Germany—B. WESTERMANN & Co., of New York

FRIDAY, DECEMBER 2, 1887.

Death of General E. W. Leavenworth.

Just before going to press we received the following letter, which we regretfully place before our readers—

THE GAS LIGHT CO., SYRACUSE, N. Y.,
SYRACUSE, Nov. 28, 1887.

To the Editor AMERICAN GAS LIGHT JOURNAL:

Our President, General E. W. Leavenworth, died at his residence in this city, Saturday morning last, at the ripe old age of 85 years. General Leavenworth has been identified with the growth and prosperity of our beautiful city for the past 60 years, having seen it grow up from a hamlet to a city of 90,000 inhabitants. He has been identified with the establishment of very many of the business enterprises of the city, and was foremost in founding and promoting various churches and charitable institutions. He was a leading citizen, socially and politically; his services in the latter capacity being acknowledged by his having been called upon to fill various important places in our Municipal and State Governments, as well as in the affairs of the Nation.

The General had been connected with our Company since 1853, and, for 27 years, was active in the management of its affairs, most of the time acting as its President. He took great interest in gas matters in a general way, and was a pronounced believer in the efficacy of gas light associations organized to promote the interests of gas companies. As early as 1858 the deceased, with others, organized an Association of Gas Light Companies of the State of New York, General Leavenworth being its first President. This, I believe, was the first gas light association organized in this country. He was also present at the first meeting of the American Gas Light Association, and materially assisted in perfecting its organization, in April, 1873.

There was a very large attendance at the funeral services, and the evidences of respect for

the deceased, who had departed this life after a career of great activity and public usefulness, were many and sincere. The numerous organizations with which General Leavenworth had been connected, paid feeling tributes to his memory, and just recognition of his part in life's busy activities, and they were represented by delegations attending the funeral services. In the carriages which formed the funeral procession, besides the members of the family, were the trustees of the First Presbyterian Church; trustees of the Syracuse Savings Bank; trustees of the Syracuse Gas Light Company; also the trustees of the Syracuse Water Works, and representatives from other organizations with which the deceased was identified.

Yours very truly,
A. C. WOOD.

The Market for Gas Securities.

The city gas share market was featureless during the fortnight, but values were fairly well maintained. The Consolidated Company has declared a dividend of 2 per cent., payable on and after 15th inst., to stockholders of record of Nov. 30. The transfer books will be reopened on the 16th.

The earnings of the Company were quite satisfactory during the six months, and from the surplus carried over we expect that the June return to stockholders will be at least at the rate of 5 per cent. per annum.

A meeting of the stockholders of the Equitable Company will be held at the office, 640 Third avenue, on the 13th inst. If we had any Chicago Gas Trust shares we would be inclined to part with them, even at ruling figures.

Baltimore securities are weaker, but Consolidated looks like a purchase, as does Louisville (Ky.) stock.

Cincinnati (Ohio) gas is a shade under previous figures.

Anyone who wants to dispose of old Poughkeepsie (N. Y.) gas can find a purchaser by writing to us, provided anything like a fair figure is asked.

Gas Stocks.

Quotations by Geo. W. Close, Broker and Dealer in Gas Stocks.

16 WALL ST., NEW YORK CITY.

DECEMBER 2.

All communications will receive particular attention.
The following quotations are based on the par value of \$100 per share.

	Capital.	Par.	Bid	Asked
Consolidated.....	\$35,430,000	100		72½
Central.....	440,000	50	30	—
“ Scrip.....	220,000	—	47	57
Equitable.....	2,000,000	100	110	—
“ Bonds.....	1,000,000	—	113	115
Harlem, Bonds.....	170,000	—	—	—
Metropolitan, Bonds....	658,000	—	110	113
Mutual.....	3,500,000	100	90	92
“ Bonds.....	1,500,000	1000	101	—
Municipal, Bonds.....	750,000	—	—	—
Northern.....	125,000	50	30	—
“ Scrip.....	108,000	—	—	—
Yonkers.....	—	50	—	80
Richmond Co., S. I.	300,000	50	50	—
“ Bonds.....	12,000	—	—	—
Gas Co's of Brooklyn.				
Brooklyn.....	2,000,000	25	100	103
Citizens.....	1,200,000	20	50	—
“ S. F. Bonds....	320,000	1000	—	103
Fulton Municipal.....	3,000,000	100	128	130
“ Bonds....	300,000	—	—	106
Peoples.....	1,000,000	10	60	63
“ Bonds (5's).....	368,000	—	97	—
“ “ (6's).....	94,000	—	100	—
Metropolitan.....	1,000,000	100	72	76

Nassau.....	1,000,000	25	90	95
“ Cfts.....	700,000	1000	95	100
Williamsburgh.....	1,000,000	50	110	115
“ Bonds....	1,000,000	—	111	—
Out of Town Gas Companies.				
Boston (Mass.) Gas Co	2,500,000	500	220	—
Buffalo Mutual, N. Y....	750,000	100	90	95
“ Bonds....	200,000	1000	95	100
Citizens, Newark.....	1,000,000	50	140	145
“ “ Bonds..	45,000	—	—	—
Chicago Gas Trust.....	25,000,000	100	38½	39
Cincinnati G. & C. Co..	6,000,000	100	178	180
Consolidated, Balt.....	6,000,000	100	57	57½
“ Bonds....	3,600,000	—	107	107½
Chesapeake, Balt.....	1,000,000	100	90	—
“	1,000,000	—	100	102
Consumers Toronto....	1,000,000	50	192	—
Central, S. F., Cal.....	—	—	—	84
Capital, Sacramento, Cal.	—	—	57½	60
Hartford, Conn.....	750,000	25	140	142
Jersey City.....	750,000	20	168	—
Laclede, St. Louis, Mo.	2,000,000	100	125	—
Louisville, Ky.....	2,570,000	50	122	127
Little Falls, N. Y.....	50,000	100	95	100
“ Bonds	25,000	—	100	103
Montreal, Canada.....	2,000,000	100	220	221
Memphis (Tenn.) Gas...	750,000	100	—	—
“ Bonds.	240,000	100	103	—
New Haven, Conn.....	—	25	193	197
Oakland, Cal.....	—	—	35½	35½
Peoples, Jersey City... ..	—	—	—	60
“ “ Bonds..	—	—	—	—
Paterson, N. J.....	—	25	90	—
Rochester, N. Y.....	—	50	75	80
Syracuse, N. Y.....	350,000	25	—	—
St. Louis, Missouri.....	600,000	50	—	—
San Francisco Gas Co.	—	—	—	—
San Francisco, Cal.....	10,000,000	100	57½	58
Washington, D. C.....	2,000,000	20	210	—

Advertisers Index.

	Page
GAS ENGINEERS.	
Jos. R. Thomas, New York City.....	376
Wm. Henry White, New York City.....	376
Wm. Mooney, New York City.....	376
William Gardner, Pittsburgh, Pa.....	376
GAS WORKS APPARATUS AND CONSTRUCTION.	
James R. Floyd, New York City.....	379
T. F. Rowland, Greenpoint, L. I.....	379
Delly & Fowler, Phila., Pa.....	379
Kerr Murray Mfg. Co., Fort Wayne, Ind.....	368
Stacey Mfg. Co., Cincinnati, Ohio.....	379
Bartlett, Hayward & Co., Baltimore, Md.....	369
Morris, Tasker & Co., Limited, Phila., Pa.....	378
Davis & Farnum Mfg. Co., Waltham, Mass.....	378
R. D. Wood & Co., Phila., Pa.....	378
Bouton Foundry Co., Chicago, Ills.....	379
Smith & Sayre Manufacturing Co., New York City.....	379
PROCESSES.	
National Gas Light and Fuel Co., Chicago, Ills.....	370
American Gas Improvement Co., Pittsburgh, Pa.....	367
GAS AND WATER PIPES.	
Gloucester Iron Works, Phila., Pa.....	376
Mellert Foundry and Machine Co., Reading, Pa. (John Fox, Selling Agent, N. Y.).....	376
Cincinnati and Newport Iron and Pipe Co., Newport, Ky ..	376
Ohio Pipe Co., Columbus, Ohio.....	376
Pancoat & Rogers, New York City.....	376
M. J. Drummond, New York City.....	376
Wells Rustless Iron Co., New York City.....	376
R. D. Wood & Co., Phila., Pa.....	378
RETORTS AND FIRE BRICK.	
J. H. Gautier & Co., Jersey City, N. J.....	374
B. Kreischer & Sons, New York City.....	374
Adam Weber, New York City.....	374
Laclede Fire Brick Works, St. Louis, Mo.....	374
Brooklyn Retort and Fire Brick Works, Brooklyn, N. Y.	374
Borgner & O'Brien, Phila., Pa.....	374
James Gardner, Jr., Pittsburgh, Pa.....	374
Henry Maurer & Son, New York city.....	374
Chicago Retort and Fire Brick Works, Chicago, Ills.....	374
Baltimore Retort and Fire Brick Co., Baltimore.....	374
Oakhill Gas Retort and Fire Brick Co., St. Louis, Mo.....	374
Evans & Howard, St. Louis, Mo.....	375
Cincinnati Gas Retort and Fire Brick Works, Cincinnati, O.	375
Emil Lenz, New York City.....	375

GAS ENGINES.	
Schleicher, Schumm & Co., Phila., Pa.	352
Clerk Gas Engine Co., Phila., Pa.	371
SCRUBBERS AND CONDENSERS.	
G. Shepard Page, New York City.....	377
R. D. Wood & Co., Phila., Pa.....	378
REGENERATIVE FURNACES.	
Bartlett, Hayward & Co., Baltimore, Md.....	369
Fred. Bredel, New York City.....	375
GAS GOVERNORS.	
T. C. Hopper, Phila., Pa.	372
Connelly & Co., New York City.....	371
CEMENTS.	
C. L. Gerould & Co., Brooklyn, N. Y.....	374
GAS ENRICHERS.	
Standard Oil Co., Cleveland, Ohio.....	380
GAS METERS.	
Harris, Griffin & Co., Phila., Pa.....	382
American Meter Co., New York and Philadelphia.....	383
The Goodwin Gas Stove and Meter Co., Philadelphia, Pa.....	383
Heime & McIlhenny, Phila., Pa.....	383
D. McDonald & Co. Albany, N. Y.....	383
Nathaniel Tufts, Boston, Mass.....	382
Maryland Meter and Manufacturing Co., Baltimore, Md.....	382
EXHAUSTERS.	
P. H. & F. M. Roots, Connorsville, Ind.....	370
Smith & Sayre Manufacturing Co., New York City.....	379
Wilbraham Bros., Philadelphia, Pa.....	371
Connelly & Co., New York City.....	371
GAS COALS.	
Penn Gas Coal Co., Phila., Pa.....	381
Perkins & Co., New York City.....	380
Newburgh Orrel Coal Co., Baltimore Md.....	381
Despard Coal Co., Baltimore, Md.....	381
Chesapeake and Ohio R.R. Coal Agency, N. Y. City.....	381
Westmoreland Coal Company, Phila., Pa.....	381
Monongahela & Peters Creek Gas Coal Co., Pittsburgh, Pa.....	381
CANNEL COALS.	
Perkins & Co., New York City.....	380
J. & W. Wood, New York City.....	380

VALVES.	
Ludlow Valve Manufacturing Co., Troy, N. Y.....	372
John McLean, New York City.....	372
Chapman Valve Manufacturing Co., Boston, Mass.....	372
R. D. Wood & Co., Phila., Pa.....	378
The Combination Gas Machine Co., Detroit, Mich.....	375
PURIFYING MATERIAL.	
S. H. Douglas, Ann Arbor, Mich.....	375
Connelly & Co., New York City.....	371
ENGINES AND BOILERS.	
Jarvis Engineering Co., Boston, Mass.....	371
GAS LAMPS.	
The Siemens-Lungren Co., Philadelphia, Pa.....	377
G. Shepard Page, New York City.....	372
Alho-Carbon Light Co., Newark, N. J.....	357
Standard Gas Lamp Co., Phila., Pa.....	375
PURIFIER SCREENS.	
John Cabot, New York City.....	335
Geo. A. Mills, Baltimore, Md.....	372
GAS STOVES.	
American Meter Co., New York and Philadelphia.....	373
The Goodwin Gas Stove and Meter Co., Phila. Pa.....	384
The Combination Gas Machine Co., Detroit, Mich.....	375
Dinsmore Manufacturing Co., Boston, Mass.....	375
STREET LAMPS.	
J. G. Miner, Morrisania, New York City.....	335
Bartlett Street Lamp Mfg Co., New York City.....	367
BURNERS.	
C. A. Gefroerer, Phila., Pa.....	380
STEAM BLOWER FOR BURNING BREASE.	
H. E. Parson, New York City.....	340
GAS FIXTURES.	
Mitchell, Vance & Co., New York City.....	372
GASHOLDER TANKS.	
W. C. Whyte, New York City.....	378
COKE CRUSHER.	
C. M. Keller, Columbus, Ind.....	381
ELECTRICAL APPARATUS.	
Waterhouse Electric & Manufg Co., Hartford, Conn.....	367

BOOKS, ETC.	
English Journal of Gas Lighting.....	367
Goodwin's Directory of Gas Light Companies.....	380
King's Treatise.....	372
Scientific Books.....	382
Management of Small Gas Works.....	376
Newbigging's Gas Manager's Handbook.....	382
Gas vs. Electricity.....	375
Practical Electric Lighting.....	371
Electric Light Primer.....	371

Bartlett Street Lamp Mfg. Co.



Globe Lamps,

FOR
Streets, Parks, Public
Buildings, Railroad
Stations, etc.

LAMP POSTS

A Specialty.

Office and Salesroom,
40 & 42 COLLEGE PLACE, - - N. Y. CITY.

Gas Companies and others intending to erect Lamps
and Posts will do well to communicate with us.

ENGLISH
"Journal of Gas Lighting."

Issued weekly. New volume commences Jan. 1, 1887. Price, \$7
per annum. Subscriptions taken by

CHARLES NETTLETON, Agent for U. S.,
NO. 115 BROADWAY, N. Y. CITY.

THE ALBO-CARBON LIGHT.

THIS SYSTEM HAS SHOWN ITSELF IN THOUSANDS OF CASES—IN HALLS, CHURCHES, PICTURE GALLERIES, CONCERT
HALLS, RESTAURANTS, BANKS, CLUBS, STORES, OFFICES, and PRIVATE RESIDENCES—TO BE THE

Best Adapted and Most Successful Method of Gas Lighting Ever Offered.

The **SOFTNESS AND PURITY OF THE LIGHT** make it most desirable for Office and
Household Uses. Its **BRILLIANCY** and **POWER** render it unrivaled for lighting Halls,
Churches, etc. Its **ECONOMY** secures for it general favor wherever used.

NOTICE.—Suits are pending in the United States Circuit Courts in Illinois and Pennsylvania against various parties for infringe-
ment of our Letters Patent No. 247,925, dated October 4, 1881, and No. 333,862, dated January 5, 1886. The first of these suits has come
up for hearing, and an injunction has been granted therein. The second of said suits has not yet been reached for hearing. All persons
are cautioned against manufacturing, selling, or using any apparatus or material which infringes our patents. We intend to prosecute all
parties infringing patents owned by us.

ALBO-CARBON LIGHT CO. (Sole Manufacturers for the United States) Main Office, Newark, N. J.

illuminating Gas from Natural Gas.

THE AMERICAN GAS IMPROVEMENT CO., Limited, 95 Fifth Avenue,
Pittsburgh, Pa.

Erect Apparatus for the treatment of Natural Gas for an Illuminant under the

McKAY-CRITCHLOW SYSTEM.

Satisfaction in Economy and Quality Guaranteed.

Apparatus adapted to the manufacture of Water Gas, without any change whatever, should it be desirable to do so
on account of Natural Gas playing out. Apparatus erected or Licenses sold at the following Works.

Pittsburgh Gas Works, J. H. McElroy, Engr.
Allegheny Gas Works, Robt. Young, Engr.
East End Gas Works, W. H. Denniston, Engr.
West Pittsburgh Gas Works, E. C. Critchlow, Supt.
Beaver Falls Gas Works, H. F. Dillon, Supt.
Titusville Gas Works, E. T. Roberts, Treas.
Salamanca, N. Y.
Jamestown, N. Y.
Meadville, Pa., Wm. Reynolds, Prest.

Warren, Pa., S. S. Franklin, Supt.
Franklin, Pa., C. W. Gilfillan, Prest.
Oil City, Pa.
Erie Gas Co., Erie, Pa., W. H. Hill, Engr.
Greensburg, Pa., Jas. C. Clarke, Prest.
Sewickley, Pa., J. W. F6rb6s, Supt.
Bellaire, Ohio, John Ferguson, Supt.
New Castle, Pa., D. T. Flick, Supt.
Corry, Pa.

Sharon, Pa., S. Perkins, Prest.
Fort Scott, Kansas, L. K. Scofield, Owner.
Fostoria, Ohio, Jos. Gwynn, Supt.
Emporia, Kansas.
Tiffin, Ohio.
Wellsville, Ohio.
Brownsville, Pa.

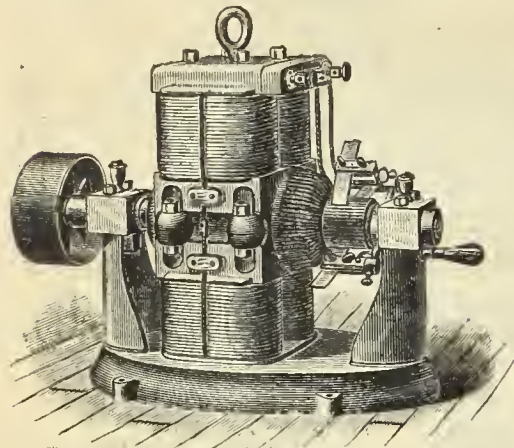
COMPETITION!**Closed Circuit Versus Open Circuit!**

During the month of September a Waterhouse (Closed Circuit) plant, of 185 2000-C.P. lights, consumed **\$50 LESS COAL** than a plant of 150 2000-C.P. lights of a well-known system (Open Circuit), with which it is competing.

185 TO 150 IS THE PEOPLE'S VERDICT!

Fine, Large, Steady Lights! Instantaneous Automatic Regulation!

It Costs No More to Buy the Best.

THE WATERHOUSE ELECTRIC AND MFG. COMPANY,
Factory, Colt's West Armory. Hartford, Conn.

To All Whom It May Concern!

The SIEMENS-LUNGREN COMPANY hereby warns the public against the use of various infringing Regenerative Gas Lamps which are offered for sale. This Company has heretofore delayed bringing suit to enjoin the manufacture or importation of such infringing lamps, solely because of the practical worthlessness of the infringing devices; and although, in each instance, they infringe some one or more of the various patents owned or controlled by this Company, they have fallen into disuse sooner than any suit could be brought to a hearing. As, however, the introduction of these infringing lamps has tended to discredit the practicability of our Company's system of regenerative gas lighting, we have instructed our Attorneys, Messrs. Geo. Harding, C. S. Whitman, and Silas W. Pettit, to give notice that legal proceedings will in future be taken against all such infringers.

THE SIEMENS-LUNGREN CO., 21st St. & Washington Av., Phila., Pa.

FOR

GAS WORKS APPARATUS

AND

GASHOLDERS,

ADDRESS

KERR MURRAY MANUFACTURING COMPANY,

FORT WAYNE, IND.

BARTLETT, HAYWARD & CO.

Baltimore, Md.

Munich Regenerative Furnace, System Drs. Schilling & Bunte.

Greatest durability; minimum of attention; complete distillation in 3½ hours; 10 to 13 pounds of coke to hundred weight of coal; no clinker; no carbonic oxide in regenerative flues.

TWO AND THREE-LIFT TELESCOPIC GASHOLDERS,

With Wrought Iron Tanks, constructed above ground, of any magnitude.

Condensers, Scrubbers, Purifiers, Bench Castings, Roofs, Boilers, Etc.

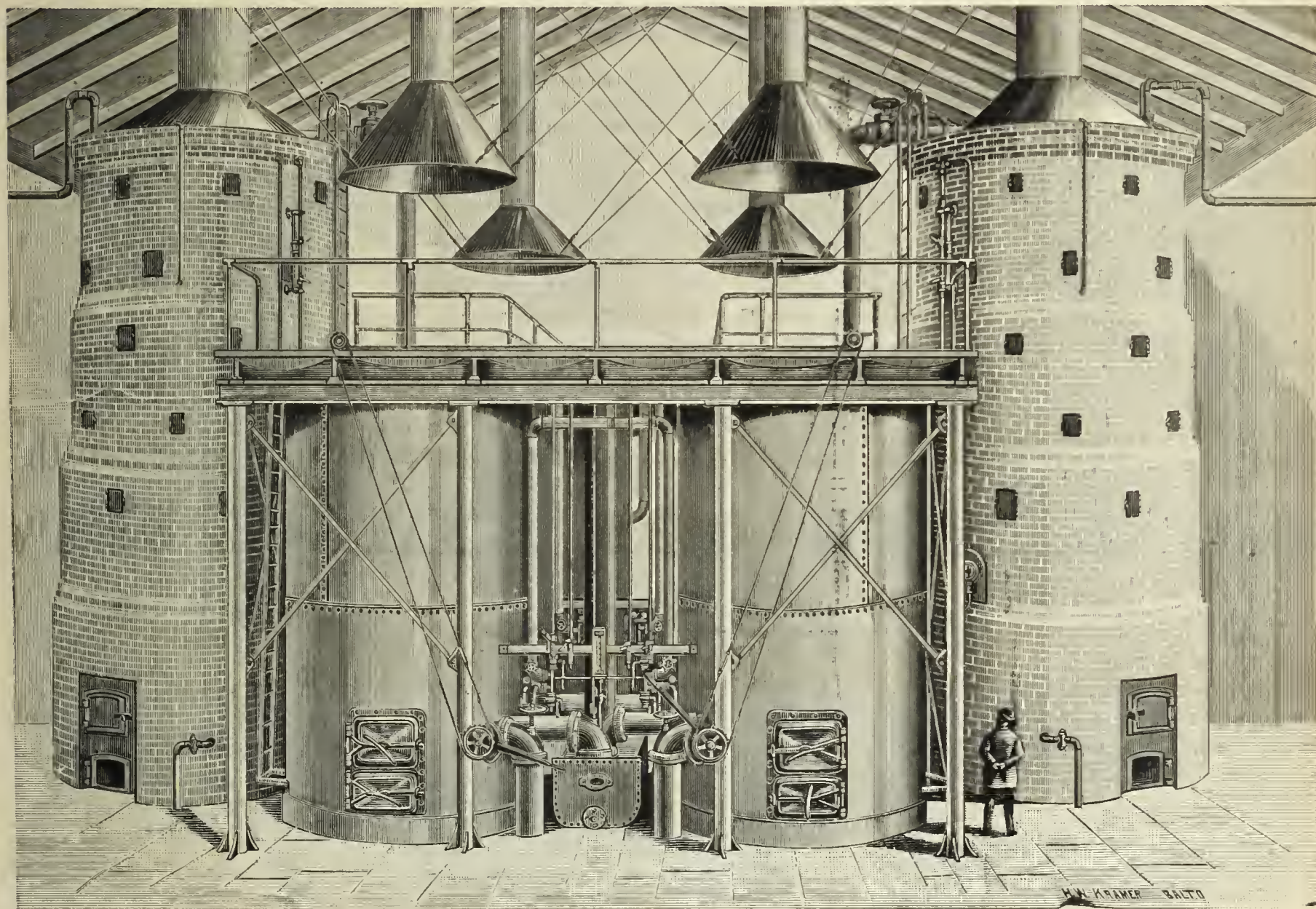

The Wilkinson Water Gas Process.

Introducing the Munich Regenerative Furnace for Coal Gas, we find on the part of many Gas Companies the desire to combine to a greater or less extent an efficient system of making high candle power Water Gas; and with a view of enabling this to be done WITHOUT EXCESSIVE CHARGES FOR PATENT RIGHTS, ETC., we have acquired, by purchase, the exclusive right to construct all the Water Gas Apparatus under the valuable "Wilkinson" Patents.

The results obtained by this Process are far better than those obtained by any other apparatus, especially where an illuminating gas of high candle power or a fuel gas of intense temperature is required.

The Process is uninterrupted, making gas of uniform quality and quantity. Its greatest advantages are maximum production with minimum material and labor, combined with great durability of apparatus.

The Process is in successful operation at the works of the N. Y. Mutual Gas Company, New York; Consolidated Gas Company, Baltimore, Md.; the Hudson County Gas Light Company, of Hoboken, N. J.; and at Rye, N. Y.

We shall be glad to give further detailed information upon application.

Sole Agents for the Celebrated Hazelton Boiler.

BARTLETT, HAYWARD & CO.

EXHAUSTERS.

EXHAUSTERS.

PROCESSES.

NATIONAL GAS LIGHT AND FUEL COMPANY,

No. 218 La Salle Street, Chicago.

THE SPRINGER SYSTEM

OF

Fuel and Illuminating Water Gas Works.

REFERENCES.

People's Gas Light and Coke Co.....Chicago, Ill.
 Elgin National Watch Co.....Elgin, Ill.
 C. R. I. & P. R. R. Shops.....Chicago, Ill.
 Decatur Gas Light and Coke Co.....Decatur, Ill.
 Niles Gas Light Co.....Niles, Mich.
 Newton Illuminating Co.....Newton, Kansas.
 Wellington Light and Heat Co.....Wellington, Kansas.
 Chippewa Falls Gas Light Co.....Chippewa Falls, Wis.
 Elkhart Gas Light and Coke Co.....Elkhart, Ind.
 Madison City Gas Light Co.....Madison, Wis.
 South Bend Gas Light Co.....South Bend, Ind.
 Sheboygan National Gas Co.....Sheboygan, Wis.
 Salina Gas Light Co.....Salina, Kansas.
 The Rathbun Co.....Deseronto, Prov. Ont.
 Jefferson City Gas Light Co.....Jefferson City, Mo.

Mankato Gas Light Co.....Mankato, Minn.
 Minneapolis Gas Light and Coke Co.....Minneapolis, Minn.
 Lima Gas Light Co.....Lima, Ohio.
 Bellevue Water and Fuel Gas Light Co..... } Bellevue, Campbell
 } County, Ky.
 Bucyrus Gas Light and Fuel Co.....Bucyrus, Ohio.
 Morris Gas Co.....Morris, Ill.
 Los Angeles Gas Co.....Los Angeles, Cal.
 San Diego Gas Fuel and Electric Lt. Co.....San Diego, Cal.
 Jackson National Gas Co.....Jackson, Mich.
 Sioux Falls Gas Co.....Sioux Falls, Dak.
 Dakota Gas and Fuel Co.....Grand Forks, Dak.
 St. Johns Mutual Gas Co.....St. Johns, Mich.
 Stillwater Gas Light Co.....Stillwater, Minn.
 St. Paul Gas Light Co.....St. Paul, Minn.

GUARANTEED ESTIMATES of Cost of Gas Furnished on Application.

ROOTS' NEW GAS EXHAUSTER.

St. Louis, Mo., {
 March 21, 1887. }
 Messrs. P. H. & F. M.
 Roots, Connersville, Ind.:
 Dear Sirs—In 1872 one of
 your No. 5 Exhausters was
 placed in these works, and
 worked satisfactorily. In
 March, 1885, it was replaced
 by one of your No. 6 Ex-
 hausters. The latter has
 been in almost constant use
 the past two years, has
 worked up to all my expect-
 ations, and is to-day in ap-
 parently as good condition
 as when first set up. It has
 not cost one cent for repairs
 in all that time. I have also

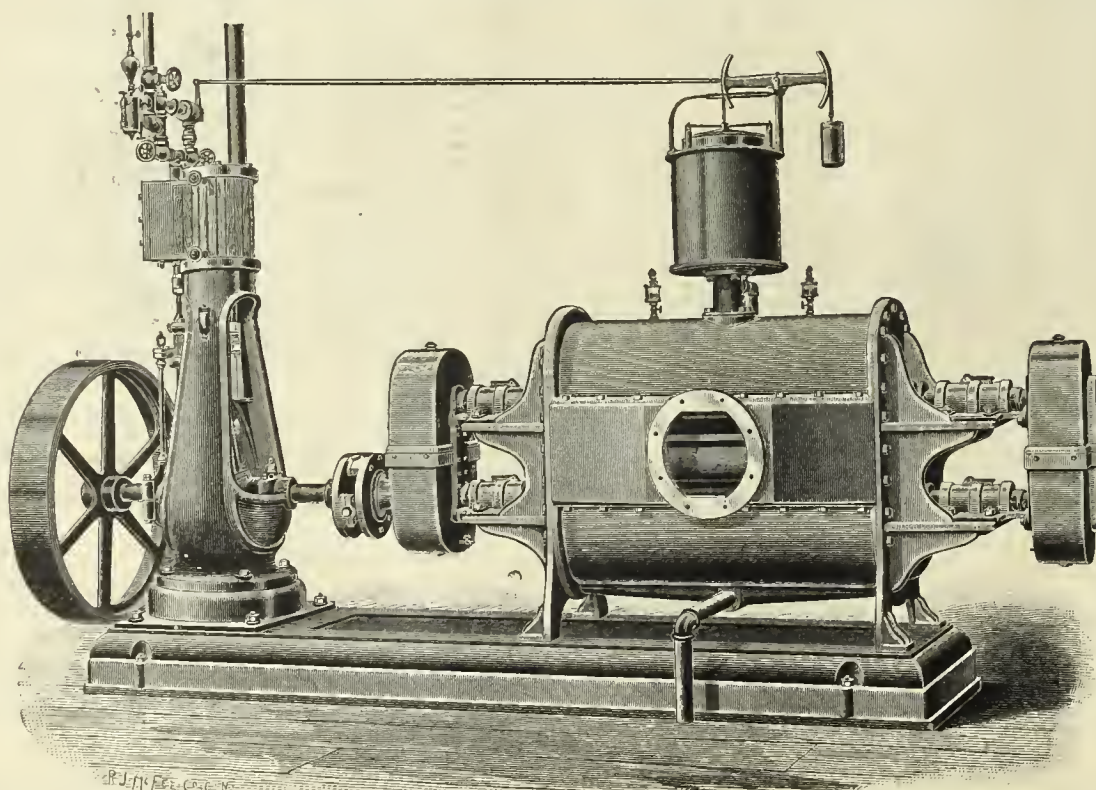

had one of your No. 1 Ex-
 hausters, with Engine on
 same bed-plate, fitted with
 your valves and Huntoon
 Governor, placed in a small
 works under my control, and
 in its operation it seems as
 near perfection as I ever ex-
 pect an Exhauster to be-
 come. Without in the least
 disparaging Exhausters of
 other makes, I may say that
 your Exhauster may be safe-
 ly recommended as unsur-
 passed by any other, to those
 requiring such machines.

Yours respectfully,
 FREDERIC EGNER,
 Eng. and Supt.

CONSTRUCTED ON ENTIRELY NEW PRINCIPLES.

THE ONLY EXHAUSTER MADE IN WHICH

The Internal Operating Parts Consist of Only Two Pieces, Each Cast Entire in One Piece.

Send for Descriptive Catalogue and Price List.

P. H. & F. M. ROOTS, Patentees and Manufacturers, **CONNERSVILLE, IND.**

S. S. TOWNSEND, Gen. Agt., 22 Cortlandt St., N. Y. COOKE & CO., Selling Agts., 22 Cortlandt St., N. Y.

CONNELLY & CO., LTD.,

SOLE MANUFACTURERS OF THEIR PATENTED SPECIALTIES.

"IRON SPONGE." Saves money, saves labor, and is the most efficient purifying agent ever offered as a substitute for lime. Now used *in every State in the Union*, and purifying daily over *twenty-five million cubic feet*. Should be used in every gas works. Its own saving will pay for it many times over.

AUTOMATIC GOVERNOR. Has been on the market but *two years*, and in that time has been introduced *more generally* than any invention ever designed for use in gas works. Over *one hundred* of them now in use. Sensitive; reliable; perfectly automatic; reduces leakage; satisfies consumers, and gives great relief to the Manager. No gas works is *complete* without one of these machines.

STEAM JET EXHAUSTER. Designed particularly for small works. Combines Exhaust Tube, Steam Governor, Gas Compensator, and Bye-Pass Valves in the most compact form possible; occupies but little space; uses very little steam; operated by ordinary workmen; saves formation of carbon in retorts; increases yield 10 to 15 per cent. Specially adapted for *mixing air* with oil gas. *No works* too small to use them profitably.

Prices given on all our specialties *delivered at any point in the United States*. Correspondence solicited.

CONNELLY & CO., LTD., No. 177 Broadway, New York City.

WILBRAHAM GAS EXHAUSTER AND ENGINE COMBINED.

WILBRAHAM BROS.,
PHILADELPHIA, PA.

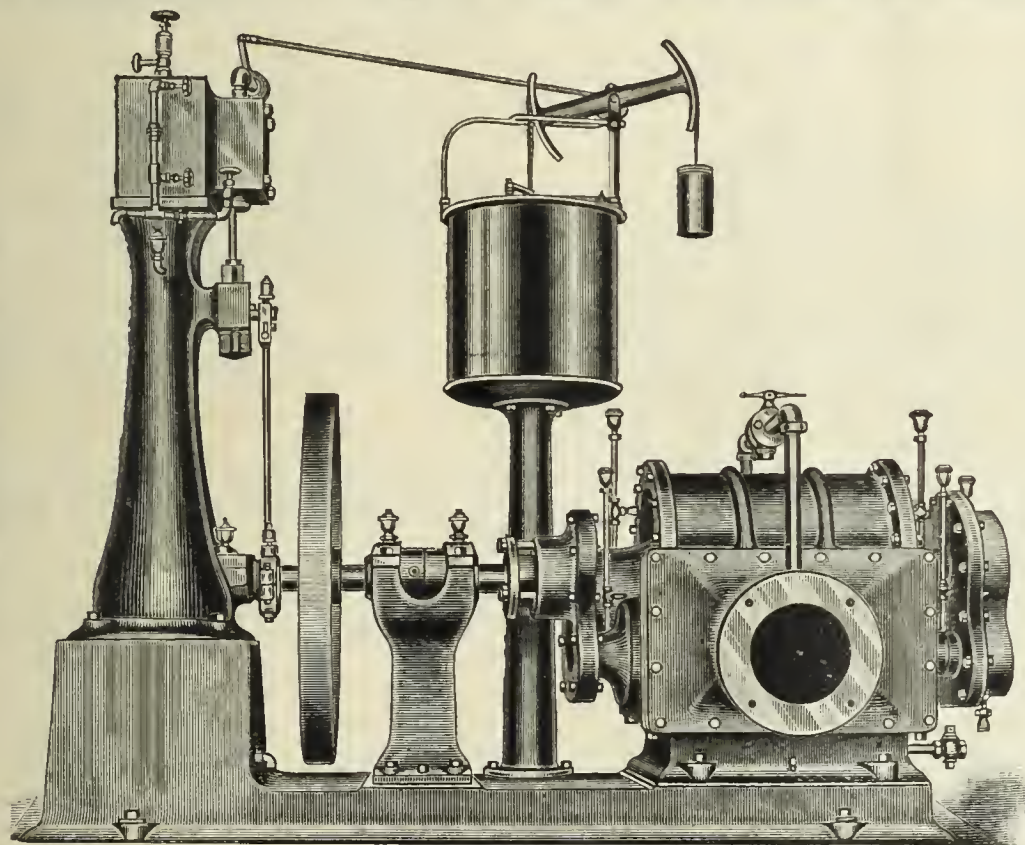

JARVIS ENGINEERING CO.,

61 Oliver St., Boston, Mass.

CONTRACTORS FOR ERECTING

COMPLETE STEAM OUTFITS FOR ELECTRIC LIGHTING STATIONS.

Steel Boilers set with Jarvis Pat. Boiler Setting

To burn **COKE SCREENINGS** for Fuel.

ARMINGTON & SIMS CO. ENGINES,

Belted direct to Dynamos, without using Shafting.

SEND FOR CIRCULARS.

REFERENCES.—Charlestown Gas & Electric Light Co., Charlestown, Mass.; Schenectady Gas & Electric Light Co., Schenectady N. Y.; Brookline Gas Co., Brookline, Mass.

Practical Electric Lighting,

By A. BROMLEY HOLMES, A.M.I.C.E.

With 87 Illustrations. Third Edition. Price, \$1.00.

Electric Light Primer.

By CHARLES L. LEVEY.

A simple and comprehensive Digest of all the most important facts connected with the running of the Dynamo and Electric Lights, with Precautions for Safety, etc.

Price, 50 cents.

A. M. CALLENDER & CO., 42 Pine St., N.Y.

THE CLERK GAS ENGINE CO.,

Main Office, 1012, 1014, 1016, 1018 Filbert St., Philadelphia, Pa.

WM. W. GOODWIN, Prest.

E. STEIN, Sec.

S. LEWIS JONES, Asst. Sec.

A. J. DOTY, Supt.

The utility and convenience of the Gas Engine being no longer an open question, it only remains now for intending purchasers to select the BEST. We claim for the CLERK GAS ENGINE that it is equal to any other manufactured as regards steadiness in running, simplicity, and ease of keeping in repair, and that it gives the greatest amount of power for the least money (both in first cost and expense of running) of any engine made. In support of this claim we refer to the test of the Gas Engines made under the direction of the American Institute of New York, in December, 1885, and heretofore published in these columns. These engines are especially adapted for continuous running under heavy loads, and we can refer to Engines which have run 22 hours a day for months at a time

Made in Sizes of 5, 10, 15, 20, and 25 Horse Power. All Engines Guaranteed for One Year.

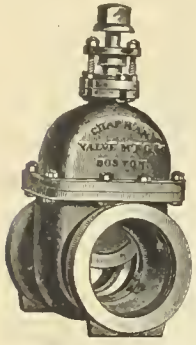

CHAPMAN VALVE MANUFACTURING CO.,

MANUFACTURERS OF

Valves and Gates for Gas, Ammonia, Water, Etc.

Also, Gate Fire Hydrants With and Without Independent Nozzle Valve. All Work Guaranteed.

WORKS & GEN'L OFFICE: Indian Orchard, Mass. TREASURER'S OFFICE: 72 Kilby & 112 Milk Sts, Boston, Mass.

LUDLOW VALVE MFG. CO.

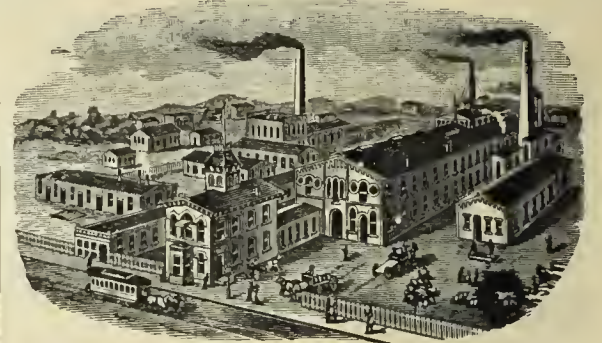

OFFICE AND WORKS, 938 to 954 River Street and 67 to 83 Vail Av TROY, N. Y.

How to Reduce Leakage to Its Minimum.

USE

HOPPER'S AUTOMATIC DIFFERENTIAL GAS GOVERNOR.

Needs No Attention. Simple, Reliable, Perfectly Automatic. "Nearly Thirty in Use."

BYE-PASSES, DRY CENTER VALVES, PRESSURE REGISTERS. Also, GOVERNORS FOR STREET MAINS, *NOT DIFFERENTIAL*, and for EXHAUSTERS, GAS ENGINES, etc. Our new Bye-Pass is threefold in its action—passes gas through, or bye-passes, or shuts off entirely. Correspondence solicited; information given. Send for circulars and testimonials.

T. C. HOPPER & CO., - - - No. 2227 Wood Street, Philadelphia, Pa.

MILLS' REVERSIBLE LIME TRAY,

AND

WOODWORK

Of Every Description

NEEDED BY GAS WORKS.

SEND FOR CIRCULAR AND PRICE LIST TO

GEORGE A. MILLS,

Canton Av. & President St., Baltimore, Md.

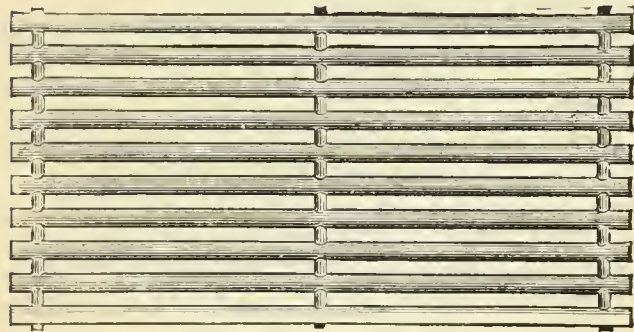

Hydraulic Main Dip Regulators, also Check Valves, Foot Valves, Yard-wash and Fire Hydrants. Send for Circulars.

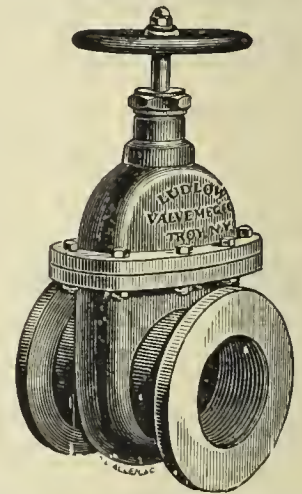

Valves.—Double and Single Gate, 1/2 in. to 48 in., outside and inside Screws. Indicator, etc., for Gas, Water, Steam, and Oil. Send for Circulars.

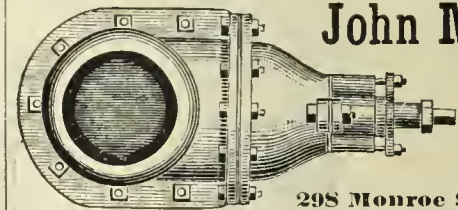

John McLean

Man'ufacturer of

GAS VALVES.

298 Monroe Street, N. Y.

GEO. SHEPARD PAGE,

No. 69 Wall Street, N. Y. City.

REPRESENTING

THE BOWER GAS LAMP.

C. & W. Walker's Carbonic Acid & Tar Extracting Washer

B. DONKIN & CO.'S PAT. IMP. GAS VALVE.

Young & Beilby's Patents. Henry Aitkin's Patents.

R. P. SPICE, London, Eng. HENRY SIMON, Manchester, ENGL.

MITCHELL VANCE & CO.,

MANUFACTURERS OF

Chandeliers

and every description of

GAS FIXTURES.

Also manufacturers of Fine Gilt Bronzes and Marble Clocks, warranted best time-keepers. Mantel Ornaments, etc.

Salesrooms, 836 Broadway, N. Y.

Special Designs furnished for Gas Fixtures for Churches, Public Halls, Lodges, etc.

KING'S TREATISE

ON THE SCIENCE AND PRACTICE OF THE

MANUFACTURE AND DISTRIBUTION OF COAL GAS.

A standard text-book for the Engineers and Managers of Gas Works, and for all who are concerned or take an interest in the manufacture and distribution of Coal Gas, and in the utilization of the Secondary Products resulting therefrom; treating also of the Gas Engine, and of Gas Cooking and Heating Appliances.

In 3 Vols. Price per Vol., \$10. Sold either by Volume or in Sets.

A. M. CALLENDER & CO.,

No. 42 Pine Street, N. Y. City.

GAS STOVES.

GAS STOVES.

GAS STOVES.

THE AMERICAN METER CO.,

MANUFACTURERS OF

GAS COOKING AND HEATING STOVES.

Gas
Heating
Stoves
in
all
Sizes
for
Parlors,
Chambers
and
Offices.

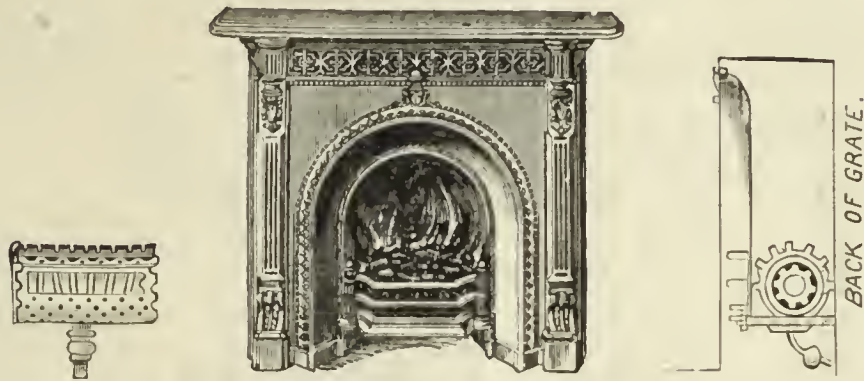

Verity's and Wilson's Patent Gas Fires For Open Fireplaces.

Gas
Cooking
Stoves
and
Ranges
in
all
Sizes
for
Family
and
Hotel
Use.



Catalogues and Price Lists on Application.

Catalogues and Price Lists on Application.

MANUFACTORIES,

508 to 514 West Twenty-second St., N. Y.

Arch and Twenty-second St., Phila

Nos. 244 & 246 North Wells Street, Chicago, Ill.

AGENCIES,

No. 177 Elm Street, Cincinnati, Ohio.

No. 222 Sutter Street, San Francisco Cal

No. 810 North Second Street, St. Louis, Mo.

GAS STOVE SHOW ROOMS, No. 223 Sixth Avenue, New York City.

RETORTS AND FIRE BRICK.

RETORTS AND FIRE BRICK.

RETORTS AND FIRE BRICK.

J. H. CAUTIER & CO.,
CORNER OF
GREENE AND ESSEX STREETS,
JERSEY CITY, N. J.

MANUFACTURERS OF

**Clay Gas Retorts,
Gas House Tiles,
Fire Bricks, Etc. Etc.**

**Ground Clay, Fire Brick and
Fire Sand in Barrels,**

J. H. GAUTIER.
C. E. GREGORY.

T. B. GAUTIER.
C. E. GAUTIER.

**BROOKLYN
Clay Retort & Fire Brick Works,**
(EDWARD D. WHITE & CO.)

Manufacturers of Clay Retorts, Fire Brick,
Gas House and other Tile.

VAN DYKE, ELIZABETH, RICHARDS & PARTITION STS.
Office, 88 Van Dyke St., Brooklyn, N. Y.

LAGLEDE FIRE BRICK MFG. CO.,
MANUFACTURERS OF
Fire Brick, Gas Retorts,

AND

ST. LOUIS STANDARD SEWER PIPE.

Blast Furnace and Cupola Linings, every description of Fire
Clay Material, Fire Clay Flue Linings, Chimney Tops
Dry Milled and Crude Fire Clays, etc.

OFFICE AND DEPOT

901, 903, and 905 Pine Street,
ST. LOUIS, MO.

ESTABLISHED IN 1845.

B. KREISCHER & SONS,

OFFICE FOOT OF HOUSTON ST., E.R., N. Y.

Gas Retorts,**TILES, FIRE BRICK.**

AND EVERYTHING IN THE FIRE CLAY LINE.

**MANHATTAN
FIRE BRICK & ENAMELLED CLAY
RETORT WORKS.
ADAM WEBER.**

**CLAY GAS RETORTS
AND RETORT SETTINGS
FIRE BRICKS, TILES, ETC.,**

Office and Works, 15th Street and Avenue C., N. Y.

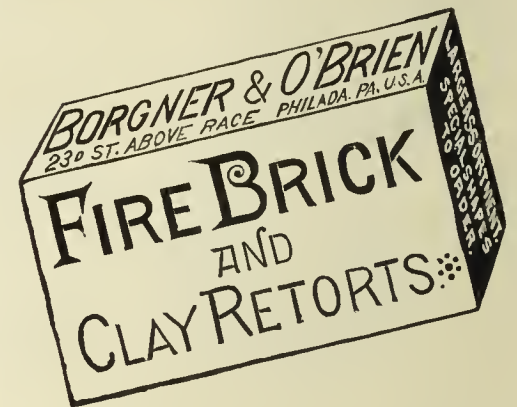

Works,
LOCKPORT STATION, PA.

—ESTABLISHED 1864.—

JAMES GARDNER, JR.,

Successor to WILLIAM GARDNER & SON.

Fire Clay Goods for Gas Works.

CHAS. H. SPRAGUE & SON, No. 70 KILBY STREET, BOSTON, MASS., Agents for the New England States.

Office, Rooms 19 & 20, Lewis Block,
PITTSBURGH, PA. P. O. Box 373.

OFFICE, 418 to 422 East 23d St., New York.

ESTABLISHED 1856.

WORKS, PERTH AMBOY, NEW JERSEY.

**HENRY MAURER & SON,
Excelsior Fire Brick & Clay Retort Works**
CLAY GAS RETORTS, BENCH SETTINGS, FIRE BRICK, TILES, ETC.

**CHICAGO
Retort & Fire Brick Works,**
OFFICE AND FACTORY,
Clark, Forty-Fifth, and La Salle Streets,
CHICAGO, ILL.

GEORGE C. HICKS, PRES. PAUL P. AUSTIN, SEC. & TREAS.

STANDARD

**Clay Retorts and Settings.
BLOCKS & TILES**
Of every Shape and Size to Order.
Standard Fire Bricks.

GEROULD'S IMPROVED RETORT CEMENT.

A Cement for patching retorts, putting on mouthpieces, and
making up all bench-work joints. This Cement is mixed ready
for use. Economic and thorough in its work. Fully warranted
to stick. For recommendations and price list address

C. L. GEROULD & CO.,
5 & 7 Skillman St., Brooklyn, N. Y.

Western Agent, H. T. GEROULD, Mendota, Ill.

**OAKHILL
GAS RETORT & FIRE BRICK
Works.**

Proprietors,

PARKER-RUSSELL MINING & MFG. CO.
City Office, 711 Pine Street,
ST. LOUIS, MO.

Our immense establishment is now employed almost entirely in
the manufacture of

MATERIALS FOR GAS COMPANIES.

We have studied and perfected three important points. Our re-
torts are made to stand changes of temperature, the strongest
heats of the furnace, and the abrasion of feeding and emptying.
Our customers are in almost every State of the Union, to all of
whom we refer

THOS. SMITH, Prest. AUGUST LAMBLA, Vice-Prest. & Sud

**BALTIMORE
RETORT & FIRE BRICK CO.**

MANUFACTORY AT

LOCUST POINT, BALTIMORE, MD.

Connection with the City by Telephone.

**Clay Retorts, Blocks & Tiles,
FIRE BRICK, FIRE CLAY,
AND FIRE CEMENT.**

Red and Buff Ornamental Tiles and Chim-
ney Tops. Drain and Sewer Pipe (from
2 to 30 inches). Baker Oven Tiles
12 x 12 x 2 and 10 x 10 x 2.

WALDO BROS., 88 WATER ST., BOSTON, MASS
Sole Agents the New England States.

EVENS & HOWARD,
916 Market St., St. Louis. Mo.
Works, Howard Station, Mo. Pacific R.R.

Fire Brick, Gas Retorts

RETORT SETTINGS.

Sewer Pipe, 3 to 24 in. diameter.
Glass Pot Clay, Ground Fire Clay, in barrels and in bulk. All kinds of Fire Clay Goods.

Cincinnati Gas Retort & Fire Brick Works.
—ESTABLISHED 1872.—

CHAS. TAYLOR,

MANUFACTURER OF

Gas Retorts, Fire Brick, and Tile.

Blast Furnace Linings, Cupola Blocks, Boiler Tiles, Grate Settings, and Stove Linings. Fire Cement, Fire Clay, Fire Sand, and all other Fire Clay Goods.

Branch Works, New Cumberland, W. Va.
GENERAL OFFICE AND WORKS,
Burns St., Cincinnati, Ohio.

EMIL LENZ,

2 & 4 Stone St., N. Y. City.

CLAY GAS RETORTS

(ENAMELED.)

Fire Brick, Blocks & Tiles.

FIRE CEMENT, RETORT ENAMEL, RETORT CEMENT, ETC., ETC.

Regenerative and Half-Regenerative Benches.
PORTLAND CEMENT.

Correspondence Respectfully Solicited.

GAS vs. ELECTRIC LIGHT.

We would invite attention to the able and exhaustive argument of General A. Hickenlooper, President of the Cincinnati Gas Light and Coke Company, contained in a handsome pamphlet of 96 pages, entitled

"EDISON'S INCANDESCENT ELECTRIC LIGHTS FOR STREET ILLUMINATION. REPORT OF AN ARGUMENT DELIVERED BY A. HICKENLOOPER BEFORE THE COMMITTEE ON LIGHT, MUNICIPAL COUNCIL, CITY OF CINCINNATI, JULY 22, 1886."

This is a subject of special interest to all Gas Light Companies.

Prices.

25 copies.....	\$7.50	100 copies.....	\$22.50
50 copies.....	12.50	250 copies.....	50.00

A sample copy will be sent by mail on receipt of 50 cts.

A. M. CALLENDER, & CO., 42 PINE ST., N. Y. CITY.

PATENTS.

FRANKLIN H. HOUGH,

Solicitor of American & Foreign Patents

925 F. ST., WASHINGTON, D. C.

(NEAR U. S. PATENT OFFICE.)

Personal attention given to the preparation and prosecution of applications for Letters Patent. All business before the U. S. Patent Office attended to for moderate fees. **No Agency in the United States possesses superior facilities for obtaining Patents,** or for ascertaining the patentability of inventions. Copies of patents furnished for 25 cents each. Correspondence solicited.



STEPHEN A. MORSE, President.
GODFREY REBMAN, Vice-Pres.

M. B. DYOTT,
Superintendent.

EDWIN F. MORSE, Secretary.
CARLTON M. WILLIAMS, Treas.

STANDARD GAS LAMP CO.,

Office, 411 Cherry St. Factory, 1101, 1103 & 1105 Frankford Av.

Philadelphia, Pa.

It is to the interest of Gas Companies and Cities to use Dyott's Patent Champion Lamps, which give double the light with the same consumption of gas, and will save 50 per cent. over others in cost of keeping in repair. Gas Companies and others intending to erect Lamps of any description will do well to communicate with us. Special Drawings furnished and Estimates given on application upon Architects', Engineers' or our Draughtsmen's Plans.

Our Patent System of Instantaneously Lighting Gas (without electricity) for R. R. Depots is unequalled. Our High Candle Power Burner is superior to the Electric Light or any other High Candle Burner. We manufacture every description of Ornamental Lamps.

KLOENNE & BREDEL

IMPROVED REGENERATIVE FURNACES.

Self-Sealing Mouthpieces & Bridge-Pipes, Retort Houses,
WASHER-SCRUBBERS
Gasholders, and Complete Gas Works.

Refers, by permission, to Mr. Eugene Vanderpool, of Newark, N. J.; Mr. E. G. Cowdery, of Milwaukee, Wis.; and Mr. Theo. Forstall, of Chicago, Ill. For further information apply to

FRED. BREDEL, 332 East 17th St., N. Y. City.



GAS STOVES

OF EVERY DESCRIPTION, FOR HEATING, COOKING, LABORATORY, AND MECHANICAL PURPOSES.

Weber Straight-Way Valves,

FOR GAS, STEAM, AND WATER.

Send for Catalogue "C."

Correspondence Solicited.

THE COMBINATION GAS MACHINE CO.,

Detroit, Mich.

Windsor, Ont.

163 Maiden Lane, N. Y. City.

87 Dearborn St., Chicago, Ill.



CONE GAS STOVE

FOR HEATING rooms of any size. Perfect combustion. No injurious odors to be carried away by a chimney. Warranted odorless, or the purchase money refunded. **DINSMORE MFG. CO., 28 Kneeland Street, Boston, Mass.** Send for Catalogue.

BOOKS.

DISTILLATION OF COAL TAR AND AMMONIACAL LIQUOR.

By **GEORGE LUNGE.** Price \$8.50.

A TREATISE ON THE COMPARATIVE COMMERCIAL VALUES OF GAS COALS AND CANNELS.

By **DAVID A. GRAHAM.** 8vo., Cloth. Price \$3.

Orders for these books may be sent to this office.

A. M. CALLENDER & CO.,

42 PINE ST., N. Y. CITY.

Ferric Oxide for Gas Purification.

Ferric Oxide, as ground, screened, and prepared by me for purifying purposes, has now been in use for several years by many of the gas works throughout the country, including Detroit, Chicago, Milwaukee, East Saginaw, Burlington (Iowa), Ann Arbor, etc. It has proved, as I believe, the **Most Effective and Economical Agent** now in use. I am prepared to furnish the Oxide by the 100 lbs. or in car load lots, and will be pleased to give price f.o.b. cars at Ann Arbor or at place of destination. Address

S. H. DOUGLAS, Prest. Ann Arbor (Mich.) Gas Light Co.

GAS AND WATER PIPES.

GAS AND WATER PIPES.

ENGINEERS.

SAM'L R. SHIPLEY, Pres.
HENRY B. CHEW, Treas.

JAS. P. MICHELLON, Sec.
WM. SEXTON, Supt.

GLOUCESTER IRON WORKS,
GLOUCESTER CITY, N. J.



Cast Iron Gas & Water Pipes, Stop Valves, Fire Hydrants, Gasholders. &c.

Office No. 6 North Seventh Street, Philadelphia.

MATTHEW ADDY, President.

W. L. DAVIS, Selling Agent.

GEO. P. WILSHIRE, Sec. & Treas.

Cincinnati and Newport Iron and Pipe Company,
NEWPORT, KY.

Lamp Posts
AND
BENCH CASTINGS



Branch
AND
SPECIAL CASTINGS

A Specialty.

Large & Heavy Castings for General Work.

FOR GAS & WATER CO'S

Manufacture Pipe from 2 to 48 inches. All work guaranteed first quality.

Pancoast & Rogers.

WROUGHT IRON PIPE,

VALVES AND GATES,

Cast Iron Gas & Water Pipe.

28 Platt and 15 Gold St., New York.

Water & Gas Pipe.

RUSTLESS

Send for New Catalogue.

RUSTLESS

The **WELLS RUSTLESS IRON COMPANY,**

Nos. 7 and 9 Cliff Street, New York City.

The Management of Small Gas Works.

By C. J. R. HUMPHREYS. Price, \$1.

A running commentary on the different sections of gas management with reference to small undertakings, with some notes on the erection of the necessary plant.

A. M. CALLENDER & CO., 42 Pine St., N. Y.

P. D. WANNER, Chairman. A. H. MELLERT, Sec. & Treas.

MELLERT FOUNDRY & MACHINE CO., Ltd.
Reading, Pa.



Specials—Flange Pipe, Valves and Hydrants, Lamp Posts, Retorts, etc.

General Foundry and Machine Work.

JOHN FOX, Selling Agent. 160 Broadway, N. Y.

THE OHIO PIPE COMPANY,

MANUFACTURERS OF

Cast Iron Gas & Water Pipe,

BRANCH AND SPECIAL CASTINGS.

Gas-House Bench Castings, Hydraulics, Lamp Posts, Flange Pipe and Specials, Architectural Castings, Building Columns, Joists, Cellar Grates, Sash Weights, etc.

GENERAL FOUNDERS AND MACHINISTS.

Columbus, Ohio.

M. J. DRUMMOND,



SPECIAL CASTINGS AND LAMP POSTS.

Equitable Building, 120 Broadway, N. Y.

JOS. R. THOMAS, C.E.,

May be Consulted on all Matters Relating to Gas Works and Gas Manufacture.

ADDRESS THIS OFFICE.

WM. MOONEY

(Successor to WM. FARMER)

27 Pearl Street, N. Y. City.

(One door from Whitehall Street.)

CONTRACTOR FOR THE ERECTION OF GAS WORKS, OR APPARATUS OF ANY CAPACITY. AGENT FOR

WM. FARMER'S PATENTS.

Plans and Specifications Furnished.

WM. HENRY WHITE,

CONSULTING AND CONSTRUCTING

Gas Engineer & Contractor

Estimates, Plans, and Specifications furnished for new works or extensions of existing works.

No. 32 Pine Street, New York City.

Correspondence solicited.

WM. GARDNER,

Gas Engineer,

Lewis Block, Room 20, Pittsburgh, Pa.

Those who intend to make alterations in existing gas plants, or who contemplate the erection of new works, will find it to their interest to open correspondence with the above. Plans made and estimates furnished.

GAS LAMPS.

SCRUBBERS AND CONDENSERS.

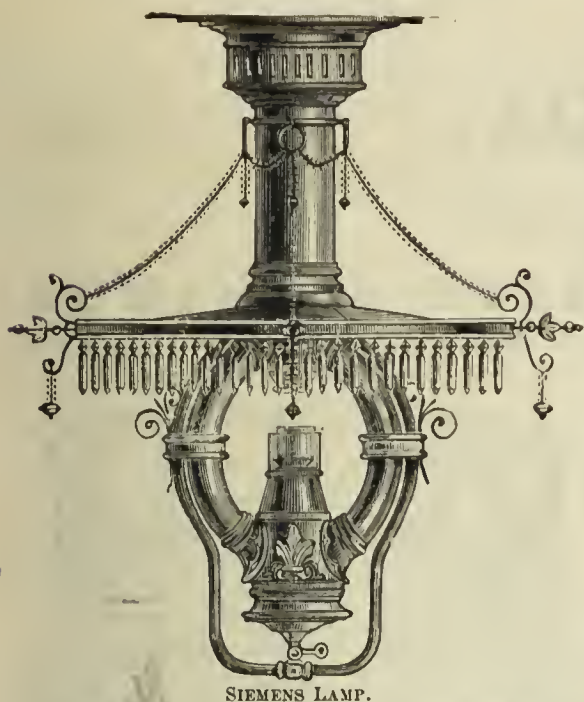

SIEMENS LAMP.

The Siemens and Lungren REGENERATIVE GAS LAMPS.

A System of Burning Gas whereby its Illuminating Power is Increased from 300 to 400 per ct. without the Expense, Trouble and Annoyance resulting from the use of Hydrocarbon Enriching Material.

The Siemens-Lungren Company received the only Silver Medal or Highest Award for Gas Burners at the "Novelties" Exhibition of the Franklin Institute, held at Phila., Oct., '85.



LUNGREN LAMP

THIRTEEN CANDLE POWER PER CUBIC FOOT OF GAS!

This result is obtained

SIMPLY BY THE SCIENTIFIC APPLICATION OF THE REGENERATIVE PRINCIPLE.

Consequently this largely increased illumination is always maintained without further cost and frequent attention.

THE SIEMENS-LUNCREN COMPANY,

N. E. Cor. 21st. St. and Washington Av., Phila. Pa.

KIRKHAM, HULETT & CHANDLER, Limited,
London, S. W., England.

PATENT "STANDARD" WASHER-SCRUBBERS.

Following are extracts from letters received from some of the Gas Light Companies now using the "Standard" Washer-Scrubber:

GEO. SHEPARD PAGE, Esq.:

SAN FRANCISCO, Sept. 21, 1887.

Dear Sir—In reply to yours, would say that the ammonia is entirely removed from the gas by the use of the "Standard" Washer-Scrubber.

Yours truly, J. B. CROCKETT, Prest.,
San Francisco Gas Lt. Co.

GEO. SHEPARD PAGE, Esq.:

BOSTON, MASS., Aug. 30, 1887.

Dear Sir—The "Standard" Washer-Scrubber at these works is giving good satisfaction, and the increased amount of ammonia eliminated from the gas by its use enables us to obtain a larger income from the ammoniacal liquor.

Truly yours, THOS. J. PISHON, Supt.,
Roxbury Gas Lt. Co.

GEORGE SHEPARD PAGE, Esq.:

GEORGETOWN, D. C., Sept. 27, 1887.

Dear Sir—The "Standard" Washer-Scrubber, together with all the work of connecting the same with these works, has given entire satisfaction.

Truly yours, J. B. CATHELL, Supt.,
Georgetown Gas Lt. Co.

GEORGE SHEPARD PAGE, Esq.:

BROOKLYN, N. Y., Sept. 8, 1887.

Dear Sir—By the use of the "Standard" Washer-Scrubber at these works the ammonia is entirely removed from the gas, and our income from the ammoniacal liquor has been increased 100 per cent.

Yours truly,
C. W. BLODGET, Sec.,
Williamsburgh Gas Lt. Co.

GEO. SHEPARD PAGE, 69 WALL STREET, NEW YORK,

Agent for the Western Hemisphere.

GAS WORKS APPARATUS AND CONSTRUCTION.

GAS WORKS APPARATUS AND CONSTRUCTION.

WORKS: { MILLVILLE, N. J.
FLORENCE, "
CAMDEN, "

R. D. WOOD & CO.,

OFFICES: { 400 CHESTNUT ST.,
PHILADELPHIA.

GAST-IRON PIPE 1½ to 72 Inches in Diameter.

Water Machinery and Gas Apparatus.

HEAVY CASTINGS.

HOLDERS,

PURIFIERS,

FLOORS AND ROOFS,

LAMP POSTS,

CONDENSERS,

FLANGED PIPE,

VALVES,

BENCH WORK,

FIRE HYDRANTS,

METER CASES.

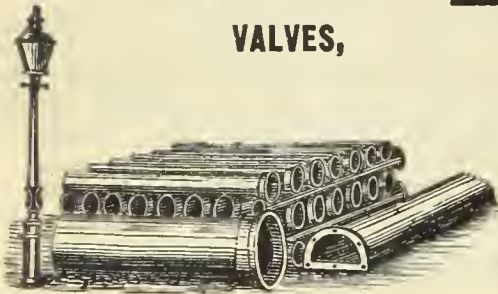

Estimates and Specifications for
NEW WORKS or **EXTENSIONS**
or **ALTERATIONS** of **OLD ONES.**

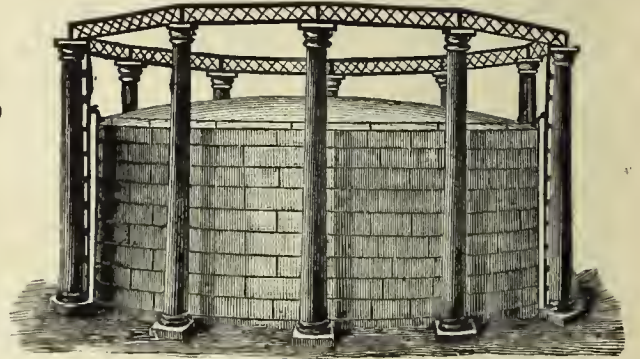

GASHOLDER TANK CONSTRUCTION, ETC.

Gas Companies and others about to erect Gasholders will find it profitable to consult W. C. WHYTE, who for over thirty years has made a specialty of

Holder Tank Excavation and Mason Work.

Fifty tanks now in operation show the sort of work done. Address

W. C. WHYTE, No. 15 Cortlandt St., N. Y. City.

MORRIS, TASKER & CO.,

Limited,

Builders of Gas Works,

PHILADELPHIA PA.

F. J. DAVIS & J. R. FARNUM,

TRUSTEES AND AGENTS FOR THE

SINUOUS FRICTION CONDENSER.

We desire to draw the attention of the gas community to the merits of the **SINUOUS FRICTION CONDENSER**. Companies intending to introduce new condensers into their works will do well to confer with us and examine plans and estimates before contracting for any other pattern. The **FRICTION CONDENSER** is now in use at the gas works located in the following places:

- | | | | |
|--------------------------------|------------------|-------------------------------|---------------------|
| Portland, Me. | Brookline, Mass. | Pawtucket, R. I. | Frederickton, N. B. |
| Newport, R. I. | Chelsea, Mass. | Jamaica Plain, Mass. | St. John, N. B. |
| Gloucester, Mass. | Woburn, Mass. | Attleboro, Mass. | Paterson, N. J. |
| Newton & Water-
town, Mass. | Peoria, Ill. | Calais, Me. | Dover, N. H. |
| | Clinton, Mass. | Fall River, Mass. | Waltham, Mass. |
| | | Nassau Works, Brooklyn, N. Y. | |

DAVIS & FARNUM MFG. CO.

MANUFACTURERS OF

Gas and Water Pipes,

AND

GAS AND WATER MACHINERY

OF THE MOST APPROVED PATTERN.

Also, Gasholders and Iron Roofing.

Orders from Gas and Water Companies promptly attended to.

WALTHAM, MASS.

Boston Office, Room 55, Mason Building, 70 Kilby Street.

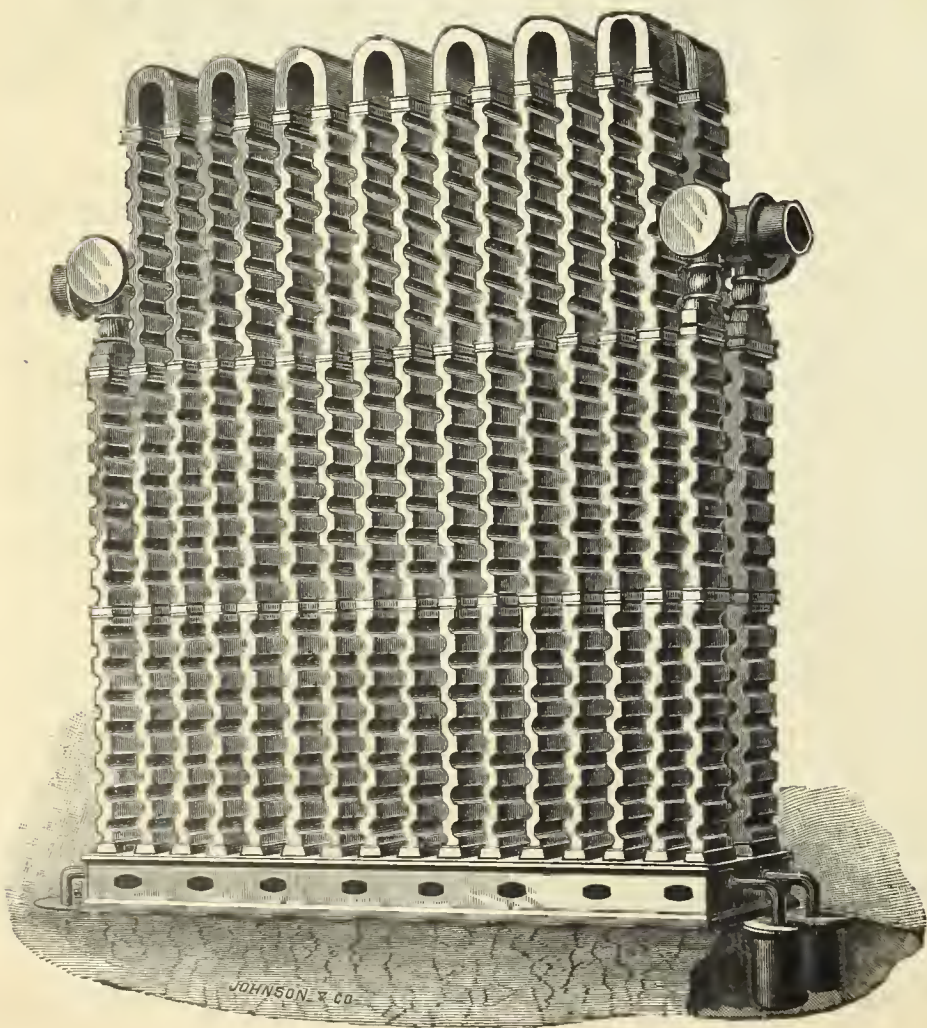

GAS WORKS APPARATUS AND CONSTRUCTION.

GAS WORKS APPARATUS AND CONSTRUCTION.

JAMES R. FLOYD,

(SUCCESSOR TO HERRING & FLOYD)

Oregon Iron Works,

531 to 543 West 20th St., N. Y.

Practical Builders of Gas Works,

MANUFACTURERS OF

ALL KINDS OF CASTINGS

AND

APPARATUS FOR GAS-WORKS.

BENCH CASTINGS

from benches of one to six Retorts each.

WASHERS: MULTITUBULAR AND AIR CONDENSERS; CONDENSERS; SCRUBBERS

(wet and dry), and

EXHAUSTERS

for relieving Retorts from pressure.

BENDS and BRANCHES

all sizes and description.

FLOYD'S PATENT

MALLEABLE RETORT LID.

PATENT

SELF-SEALING RETORT LIDS.

FARMER'S

PATENT BYE-PASS DIP-PIPE.

SABBATON'S PATENT

FURNACE DOOR AND FRAME.

BUTLER'S

COKE SCREENING SHOVELS.

GAS GOVERNORS,

and everything connected with well regulated Gas Works at low price, and in complete order.

SELLER'S CEMENT

for stopping leaks in Retorts.

N. B.—**STOP VALVES** from three to thirty inches—

at very low prices. Plans, Specifications, and Estimates furnished.

THE CONTINENTAL IRON WORKS.

THOS. F. ROWLAND, Prest. WARREN E. HILL and CHAS. H. CORBETT, V.-Prests. THOS. F. ROWLAND, JR., Sec. & Treas.



GAS HOLDERS OF ANY MAGNITUDE.

P. O. Station G., BROOKLYN, N. Y.

ENGINEERS AND MANUFACTURERS OF

Gas Holders

CONDENSERS, SCRUBBERS, VALVES,

PURIFIERS, SELF-SEALING RETORT LIDS,

Hydraulic Mains,

And all other articles connected with the manufacture and distribution of Gas.

H. RANSHAW, Prest. & Mangr. WM. STACEY, Vlee-Prest. T. H. BIRCH, Asst. Mangr. R. J. TARVIN, Sec. & Treas.

STACEY MFG. CO.,

MANUFACTURERS OF

Single and Telescopic Gasholders,

IRON ROOFS, BRIDGES, LAMP POSTS,

Water and Oil Tanks, Coal Elevator Cars,

COKE CRUSHERS, BENCH CASTINGS,

And all kinds of Wrought and Cast Iron Work used in the erection of Coal and Oil Gas Works, Rolling Mill Machinery and Heavy Castings a Specialty.

Foundry:

33, 35, 37 & 39 Mill Street.

Wrought Iron Works:

16, 18, 20, 22, 24 & 26 Ramsey Street.

Cincinnati, Ohio.

Bouton Foundry Co.,

FOUNDERS AND MACHINISTS,

CHICAGO, ILL.

Gas Works Apparatus,

PURIFIERS, CONDENSERS,

Bench Work,

SPECIALS, LAMP POSTS,

SCRUBBERS,

Iron Roofs and Floors.

Plans and Estimates furnished for new works or extensions of old works.

1842. **DEILY & FOWLER,** 1887.
Laurel Iron Works.

Address, No. 39 Laurel Street, Philadelphia, Pa.

MANUFACTURERS OF

GASHOLDERS,

Single and Telescopic.

Holders Built 1882 to 1886, Inclusive:

- | | | | | |
|---------------------------|---------------------------|----------------------------|----------------------------|---------------------------|
| Denver, Col. | Warren, Ohio. | Allegheny, Pa. (21.) | York, Pa. | Salem, N. J. (2d) |
| Chicago, Ill. (West Side) | Bath, N. Y. | Atlanta, Ga. (2d.) | Chester, Pa. | Omaha, Neb. (2d) |
| Pittsburgh, Pa. (S. Side) | Lynn, Mass. | N.Y. City (Central Gas Co) | Hazleton, Pa. (2d.) | Lynn, Mass. (2d) |
| Pawtucket, R. I. | New Bedford, Mass. | Lynchburg, Va. (2d.) | State Island, N. Y. | Little Rock, Ark. |
| Brookline, Mass. | Waterbury, Conn. | Saylesville, R. I. | Saugerties, N. Y. | Irvington, N. Y. |
| Sherbrooke, Can. | Deseronto, Can. | Rondout, N. Y. | Clinton, Mass. (Lan Mills) | South Boston, Mass. |
| Burlington, N. J. (2d.) | Hoosic Falls, N. Y. (2d.) | Atlantic City, N. J | Chattanooga, Tenn. | Rye, N. Y. (2) |
| Bridgeton, N. J | Bethlehem, Pa. | Augusta, Ga. | Galveston, Texas. (3a.) | Woodstock, Ont. |
| Bay City, Mich. | Atlanta, Ga. (1st.) | Waltham, Mass. (2) | Omaha, Neb. | Malden, Mass. |
| Erie, Pa. | Savannah, Ga. | Mahanov City, Pa. | Fort Plain, N. Y. | Staten Island, N. Y. (2d) |
| Jackson, Mich. | Montgomery, Ala. | New Castle, Pa. | Brunswick, Ga. | |
| Kalamazoo, Mich. (3d.) | Newport, R. I. | Long Island City, N. Y | Port Chester, N. Y. | |
| Glen Island, N. Y. | Portland, Oregon. | Macon, Ga. | New Rochelle, N. Y. | |

SMITH & SAYRE MFG. COMPANY,

G. PORTER, Prest.

245 Broadway, N. Y.

CHAS. W. ISBELL, Sec'y.

Machinery & Apparatus for Gas Works

Drawings, Plans, and Estimates Furnished for the Improvement, Extension, or Alteration of Gas Works, or for the Construction of New Works.

Mackenzie's Patent Rotary and Steam Jet Gas Exhausters, Governors, Compensators, Condensers, Washer, Scrubbers. Isbell's Patent Automatic Street Pressure Governor Gas and Water Valves, Hydraulic Main Dip Regulator, Bench Castings, etc. Purifying Boxes and "Standard" Scrubbers. Isbell's Patent Self-Sealing Retort Doors.

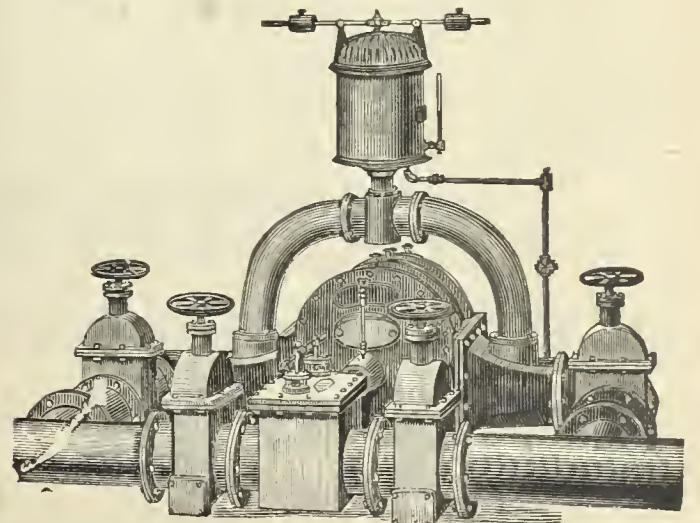

GAS COALS.

CANNEL COALS.

GAS ENRICHERS.

JAMES D. PERKINS.

PERKINS & CO.,

F. SEAVERN.

General Sales Agents for

The Youghioghenny River Coal Company's**OCEAN MINE YOUGHIOGHENY GAS COAL.**

The Coal from the Ocean Mine (recently operated by *Messrs. W. L. Scott & Co.,* of Erie, Pa.,) is now used by all the leading Gas Companies in the United States from Maine to Texas, and is recognized as *the only reliable Youghioghenny Gas Coal.* (See Map on p. 87 of this Journal, Feb. 16, '85.)

P. O. Box 3695,
New York**PERKINS & CO., 228 and 229 N. Y. Produce Exchange.**BEAVER STREET
ENTRANCE.**BRECKENRIDGE CANNEL,
OF KENTUCKY.**

This Colliery was re-opened in June, 1886, since which date the Cannel has been delivered to over sixty of the leading Gas Companies in this country and in Europe. As an enricher ONE TON of this Cannel will do the work of TWO TONS of any other available Cannel, and is more economical than Naptha or Oil of any character. It can be delivered in parcels of one car load or more to any point in the United States or Canada.

(See AMERICAN GAS LIGHT JOURNAL, June 16, '86, pp. 346-7.)

P. O. Box 3695,
New York.**PERKINS & CO., 228 and 229 N. Y. Produce Exchange**BEAVER STREET
ENTRANCE.**JAMES & WILLIAM WOOD,****Gas and Cannel Coal Contractors,**

No. 40 St. Enoch Sq., Glasgow. No. 2 Talbot Court, London.

Proprietors of the **BATHVILLE COLLIERIES** (which produce the celebrated **BOGHEAD CANNEL**), Shields, Shieldmuir, Drumpeller, and other Collieries. This Firm offer

STANDARD CANNELS,**Unequaled as Gas Enrichers.**

Analyses, prices, and all further information furnished on application to

Agency for U.S., Room 93, Nos. 2 & 4 Stone St., N.Y. City.**The Standard Oil Company,**

REFINERS OF

NAPHTHA AND GASOLINES.

ALSO MANUFACTURERS OF

**A Special Grade of Naptha for
Gas Companies****FOR ENRICHING COAL GAS.**

Correspondence solicited.

No. 43 Euclid Avenue, Cleveland, Ohio.

To Gas Companies.We make to order **CAP BURNERS** to burn any amo
under a stated pressure. Send for samples.Also, **SERVICE CLEANERS, DRIP PUMPS, and STRE
MAIN PROVING APPARATUS.****C. A. GEFRORER,**

248 N. 5th Street, Phila., Pa.

GOODWIN'S DIRECTORY**OF THE GAS LIGHT COMPANIES of the UNITED STATES & CANADA.****Price, \$3.00.**

Orders may be sent to

A. M. CALLENDER & CO., No. 42 Pine Street, N. Y. City.

COKE CRUSHERS.

Newburgh Orrel Coal and Coke Co.

MINERS AND SHIPPERS OF

Mountain Brook Steam and Smithing Coals,
**NEWBURGH, PALATINE,
 AURORA & TYRCONNELL
 GAS COALS.**

Foundry & Crushed Coke Shipped Direct from Ovens
 Mines Situated at
Newburgh, Flemington & Fairmont, W.Va.

HOME OFFICE,

33 S. Gay St., Baltimore.**CHAS. MACKALL, Gen. Mangr.**

CHAS. W. HAYS, Agent in New York,
 Room 147, WASHINGTON BUILDING, No. 1 Broadway.
 Shipping wharves at Locust Point, Baltimore.

THE DESPARD COAL COMPANY

OFFER THEIR SUPERIOR

DESPARD COAL

To Gas Light Companies and Manufacturers of Fire Clay Goods
 Throughout the Country.

ROUS. EL & HICKS, } AGENTS. { BANGS & HORTON,
 71 Broadway, N. Y. } { 16 Kilby St., Boston.

Mines in Harrison Co., West Va. Wharves, Locust Point, Balt.

Company's Office, 15 German St., Baltimore, Md.

Among the consumers of Despard Coal we name: Manhattan
 Gas Light Co., N. Y.; Metropolitan Gas Light Co., N. Y.; Jersey
 City, (N. J.) Gas Light Co.; Washington (D. C.) Gas Light Co.;
 Portland (Maine) Gas Light Co. Reference to them is requested.

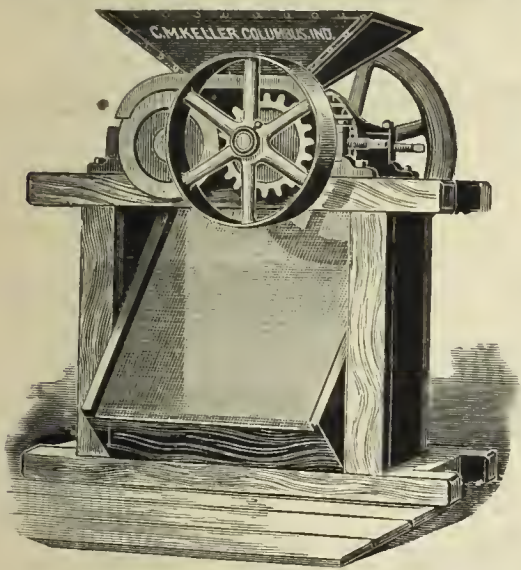
**Keller's Adjustable Coke Crusher.****SIMPLE, STRONG, AND DURABLE.**

C. M. Keller, Sec. & Supt. Gas Lt. & Coke Co. Columbus, Ind.

Correspondence Solicited.

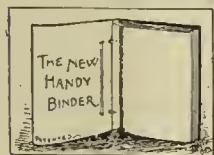
**THE NEW
HANDY BINDER.**

This article may be described as elegant
 in appearance, strong, durable, and possessing many special
 qualities of its own. It allows the opening of the pages per-
 fectly flat, whether one or several numbers are in the binder.
 Any number can be taken out and replaced without disturbing
 the others. The papers are not mutilated for subsequent bind-
 ing in permanent form. The binder is supplied with gilt side
 title, and is an ornament to any desk or reading table. The
 JOURNAL, filed in the Handy Binder, becomes a volume of great
 value, always convenient for instant reference. Handy Binder,
 Postage paid, \$1 00.

A. M. CALLENDER & CO., 43 Pine St., N. Y.

GAS COALS.

GAS COALS.

**THE
PENN GAS COAL CO.**

OFFER THEIR

Coal, Carefully Screened & Prepared for Gas Purposes

Their Property is located in the Youghiogheny Coal Basin, near Irwin and Penn Stations on the
 Pennsylvania Railroad, and on the Youghiogheny River.

Principal Office:

209 SOUTH THIRD STREET, PHILA., PA.

Points of Shipment:

Pennsylvania Railroad Piers; Greenwich Wharves, Delaware
 River; Pier No. 1 (Lower Side), South Amboy, N. J.

Chesapeake & Ohio Railway Coal Agency,

FOR THE SALE OF THE

**Superior Kanawha Gas Coals, Cannelton Cannel,
 Also, SPLINT AND STEAM COALS.**

From the Kanawha and New River Regions, on the line of the Chesapeake & Ohio R'way.

C. B. ORCUTT, Sales Agent. | OFFICE, 150 BROADWAY, N. Y.

FRANCIS H. JACKSON, Prest. EDMUND H. MCCULLOUGH, V.-Prest. CHAS. F. GODSHALL, Treas. H. C. ADAMS,

THE WESTMORELAND COAL CO.

Chartered 1854.

Mines situated on the Pennsylvania and the Baltimore
 and Ohio Railroads, in Westmoreland County, Penn.

POINTS OF SHIPMENT:

PHILADELPHIA, BALTIMORE, SOUTH AMBOY, N. J.,
 WATKINS (SENECA LAKE), N. Y.

Since the commencement of operations by this Company its well-known
 Coal has been largely used by the Gas Companies of New England and the
 Middle States, and its character is established as having no superior in gas
 giving qualities, and in freedom from sulphur and other impurities.

Principal Office, 224 South 3d St., Phila., Pa.

A. M. SCOTT, PRESIDENT.

A. DEMPSTER, C.E., SECRETARY.

W. K. GILLESPIE, TREASURER.

MONONGAHELA AND PETERS CREEK GAS COAL CO.,

PRODUCERS OF

Coal Bluff Gas Coal.

MINES LOCATED ON THE MONONGAHELA DIVISION OF THE PENNSYLVANIA RR.,
 IN THE CENTRAL PORTION OF THE PITTSBURGH COAL FIELD.

Points of Shipment—Buffalo, Cleveland, Erie, Chicago, New Orleans.

Since the introduction of Coal Bluff Gas Coal it has taken rank among the few first-class Gas Coals, and ac-
 knowledges no superior in gas-giving qualities, ease of working, quality of coke, and freedom from impurities

General Office, 43 Sixth Ave., Pittsburgh, Pa.

GAS METERS.

GAS METERS.

GAS METERS.

INTERNATIONAL--1876--EXHIBITION.

The U. S. Centennial Commission

HAVE DECREED AN AWARD TO

HARRIS, GRIFFIN & CO.,

Twelfth and Brown Streets, Philadelphia, Pa. No. 49 Dey Street, N. Y. City, and No. 75 North Clinton Street, Chicago, Ill.

FOR THE FOLLOWING REASONS :

The Exhibit consists of a Series of METERS from the Largest Size Station Meters for the use of the MANUFACTURE OF GAS, to those for the use of the ORDINARY CONSUMER. The Instruments are WELL MADE, RELIABLE as to INDICATION, and embody a number of sundry improvements which, with the general character of the Exhibit, entitle the whole to commendation.

Attest—J. L. CAMPBELL,
Secretary, pro-tem.

Signed—A. T. GOSHORN,
Director General

J. R. HAWLEY,
President

NATHANIEL TUFTS,

No. 153 Franklin Street, Boston, Mass.,

MANUFACTURER OF

DRY GAS METERS.

Station Meters of any Capacity.

Test and Experimental Meters, Pressure Registers, Pressure Gauges,
Pressure and Vacuum Gauges.

METER PROVERS, PHOTOMETERS, STREET LANTERNS, ETC., ETC.

Patent Cluster Lanterns for Street Illumination.

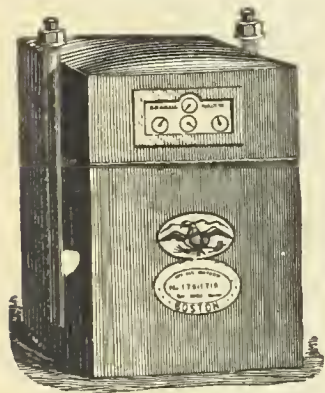

Dry Gas Meter.

With 39 years' experience and the best facilities for manufacturing, is enabled to furnish reliable work and answer orders promptly.

CHARLES E. DICKEY.

JAMES B. SMALLWOOD.

CHARLES H. DICKEY.

Maryland Meter and Manufacturing Co.,

307 and 309 Saratoga Street, Baltimore, Md.

195 and 197 Michigan Street, Chicago, Ill.

1115 Olive Street, St. Louis, Mo.

MANUFACTURERS OF

DRY GAS METERS, STATION METERS, GLAZED METERS, TEST METERS, METER PROVERS, PRESSURE & VACUUM REGISTERS,

Governors, Indicators, Service and Meter Cocks, and Meter Connections.

"SUCCESS" GAS RANGES.

Meter Repairing a Specialty.

SCIENTIFIC BOOKS.

We are prepared to furnish to Gas Managers, and others interested in the topics treated of, the following books, at prices named :

KING'S TREATISE ON THE MANUFACTURE OF COAL GAS. Three vols.; \$10 per vol.	PRACTICAL TREATISE ON HEAT, by THOMAS BOX. Second edition. \$5.	THE GAS MANAGER IN THE LABORATORY, by a Practical Student. 8vo., Cloth. \$1.50.
GAS MANUFACTURE, by WILLIAM RICHARDS. 4to., with numerous Engravings and Plates, in Cloth binding. \$12.	GAS WORKS—THEIR ARRANGEMENT, CONSTRUCTION, PLANT, AND MACHINERY. \$8.	THE DOMESTIC USES OF COAL GAS, AS APPLIED TO LIGHTING, by W. SUGG. \$1.40.
THE GAS ANALYST'S MANUAL, by F. W. HARTLEY. \$2.50.	COAL; ITS HISTORY AND USE, by PROF. THORPE. \$3.50.	DISTILLATION OF COAL TAR AND AMMONIACAL LIQUOR by GEO. LUNGE. New Edition. \$12.50.
TECHNICAL GAS ANALYSIS. \$2.80.	THE GAS WORKS OF LONDON, by COLBURN. 60 cents.	A TREATISE ON THE COMPARATIVE COMMERCIAL VALUES OF GAS COALS AND CANNELS, by D. A. GRAHAM 8vo., Cloth. \$3.
GAS MANAGER'S HANDBOOK, by THOS. NEWBIGGING. \$4.80.	THE GAS FITTER'S GUIDE, Showing the Principles and Practice of Lighting with Coal Gas, by JOHN ELDRIDGE. 40 cents.	GAS AS A SOURCE OF LIGHT, HEAT, AND POWER, by C. J. R. HUMPHREYS. 10 cents.
GAS CONSUMER'S GUIDE. \$1.	GAS WORKS, AND MANUFACTURING COAL GAS, HUGHES. \$2.20.	GAS COMPANIES DIRECTORY. \$3.
A GUIDE TO GAS LIGHTING. 40 cents.	THE MANAGEMENT OF SMALL GAS WORKS, by C. J. R. HUMPHREYS. \$1.	GAS VERSUS ELECTRIC LIGHT. 50 cents.
GAS MEASUREMENT AND GAS METER TESTING, by F. W. HARTLEY. \$1.60	MANUAL FOR GAS ENGINEERING STUDENTS, by D. LEE, 40 cents.	PURIFICATION OF COAL GAS, by R. P. SPICE. 8vo. \$3.
GAS CONSUMER'S HANDBOOK, by WILLIAM RICHARDS, C.E.; 18mo., Sewed. 20 cents.	HOW TO MANAGE GAS, by F. WILKINS. Paper. 20 cents.	
A PRACTICAL TREATISE ON GAS AND VENTILATION with Special Relation to Illuminating, Heating, and Cooking by Gas, by E. E. PERKINS. \$1.25.		

The above will be forwarded by express, upon receipt of price. We take especial pains in securing and forwarding any other Works that may be desired, upon receipt of order. All remittances should be made by check, draft, or post office money order.

A. M. CALLENDER & CO., No. 42 Pine Street, New York.

GAS METERS.

GAS METERS.

GAS METERS.

GEO. J. MCGOURKEY, Pres. WM. H. MCFADDEN, Vice-Pres. (Phila.) WM. N. MILSTED, Gen. Supt. & Treas. (New York) WM. H. DOWN Sec.

AMERICAN METER COMPANY.

WET AND DRY GAS METERS.

PRESSURE REGISTERS.

METER PROVERS.

STATION METERS.

PRESSURE & VACUUM REGISTERS.

PORTABLE TEST METERS.

EXHAUSTER GOVERNORS.

PRESSURE & VACUUM GAUGES.

EXPERIMENTAL METERS.

DRY CENTRE VALVES.

CRESSON GAS REGULATORS.

AMMONIA TEST METERS.

GOVERNORS FOR GAS WORKS.

MARSLAND WATER METERS.

BAR AND JET PHOTOMETERS.

Manufactories:512 W. 22d St., N. Y.
Arch & 22d Sts., Phila.**GAS STOVES,**SUGG'S "STANDARD" ARGAND BURNERS,
SUGG'S ILLUMINATING POWER METER,
Wet Meters, with Lizar's "Invariable Measuring" Drum.**Agencies:**177 Elm Street, Cincinnati.
244 & 246 N. Wells Street, Chicago.
810 North Second Street, St. Louis.
222 Sutter St., San Francisco.**HELME & McILHENNY,**

(Established 1848.)

GAS METER MANUFACTURERS,

Nos. 1339 to 1349 Cherry Street, Philadelphia, Pa.,

WET AND DRY GAS METERS, STATION METERS, EXPERIMENTAL METERS, METER PROVERS,

Center Seals, Pressure Registers, Governors, Indicators, Photometers, and all other kinds of Apparatus for use in Gas Works.

FOULIS' PATENT STATION AND DISTRICT GOVERNORS.**REPAIRING DEPARTMENT.**—We employ a special force of skilled workmen repairing meters of all makers.

WM. WALLACE GOODWIN, Pres. and Treas.

WM. H. MERRICK, V.-Pres.

S. L. JONES, Sec.

S. V. MERRICK, Supt.

THE GOODWIN GAS STOVE AND METER COMPANY,

Successors to W. W. GOODWIN & CO.

1012, 1014 and 1016 Filbert St., Phila., Pa.

142 Chambers St., New York.

76 Dearborn St., Chicago, Ill.

WALDO BROS., Agents, 88 Water St., Boston.

MANUFACTURERS OF THE "SUN DIAL" GAS STOVES, FOR COOKING AND HEATING PURPOSES.

Dry and Wet GAS METERS, Station Meters (Square, Cylindrical or in Staves) Glazed Meters, King's and Sugg's Experimental Meters, Lamp Post Meters, Etc., Etc., Meter Provers (sizes 2, 5 and 10 feet), Pressure Gauges of all kinds, Pressure Registers, Pressure and Vacuum Registers, Pressure Indicators (sizes 4 inch, 6 inch and 9 inch), King's Pressure and Vacuum Gauges, Dry and Wet Centre Seals, Dry and Wet Governors, Exhauster Governors, Photometers of all descriptions. Letheby's Sulphur and Ammonia Test Apparatus complete—also Testing and Chemical Apparatus of all kinds, and of the most perfect description, for all purposes relating to Gas.

GOODWIN'S IMPROVED LOWE'S JET PHOTOMETER.

Agents for Bray's Patent Gas Burners and Lanterns.Special attention to repairs of Meters, and all apparatus connected with the business.
All work guaranteed first class in every particular, and orders filled promptly.G. B. EDWARDS, Mang'r, New York.
E. H. B. TWINING, Mang'r, Chicago.
Represented by S. S. STRATTON.**D. McDONALD & CO.,****GAS METER MANUFACTURERS.**

(Established 1854.)

51 Lancaster St., Albany, N. Y. 34 & 36 West Monroe St., Chicago, Ill.

STATION METERS, EXPERIMENTAL METERS, METER PROVERS, PRESSURE & VACUUM REGISTERS, PRESSURE GAUGES, ETC.

Also STAR GAS STOVES, RANGES, and HEATING STOVES.

We use only the very best materials, and employ the most skilled labor, and by our long experience (32 years) and personal supervision of every detail, we feel justified in assuring the public that our goods will give perfect satisfaction. Every Meter emanating from our establishment will bear the State Inspector's BADGE, and will be fully warranted by us. Our Annual and Calendar will be sent to Gas Companies upon application.

GAS STOVES.

GAS STOVES.

GAS STOVES.

THE GOODWIN GAS STOVE AND METER CO.,

1012-18 Filbert St., Phila., 142 Chambers St., N. Y., 76 Dearborn St., Chicago.

Agents, WALDO BROTHERS, 88 Water Street, Boston.

WM. W. GOODWIN, PRES. & TREAS.
W. H. MERRICK, VICE-PRES.
S. LEWIS JONES, SEC.
SAMUEL V. MERRICK, SUPT.

SOLE MANUFACTURERS OF THE

G. B. EDWARDS, Mang'r, N. Y.
E. H. B. TWINING, Mang'r, Chicago.
Represented by S. S. STRATTON.

"SUN DIAL" GAS STOVES

The Most Economical, Efficient, and Durable Gas Stove Made.

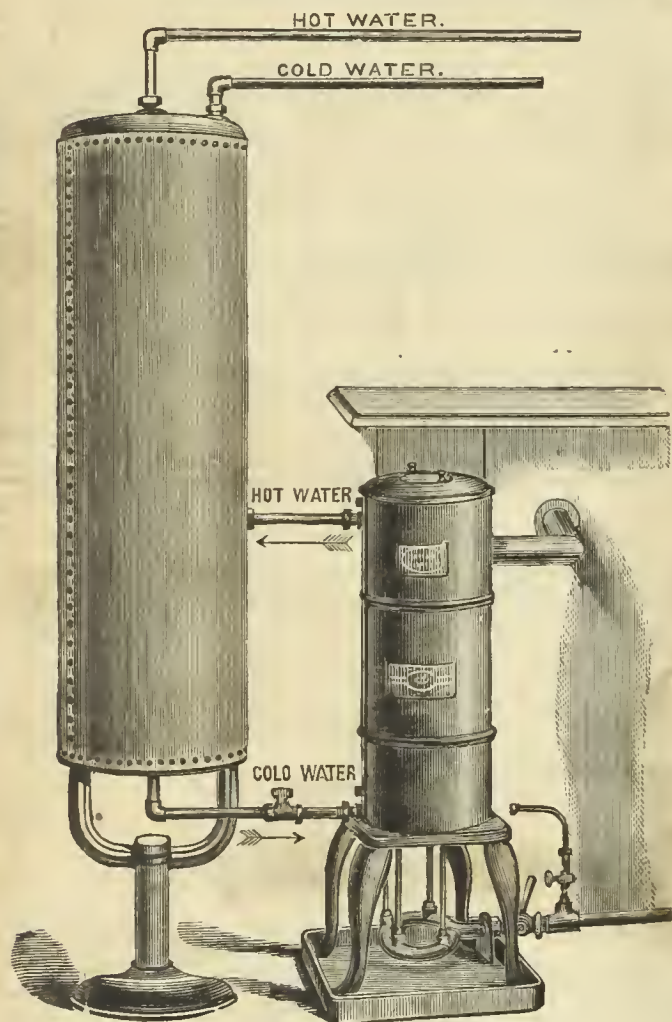

I.—Safety Hot Water Generator and Boiler.

Safety Hot Water Generator and Boiler.

Cut I. represents our Safety Gas Hot Water Generator and Boiler, arranged for home use. This most easy, quick, and economical way of preparing a warm bath, or for heating water for any domestic purpose, entirely supersedes any necessity for the use of ranges or stoves—a great comfort, particularly in hot weather. The boiler being self-filling, as the hot water is drawn off, can never become empty, thus preventing the possibility of any accident.

We beg to call attention to the cast iron pan which is now attached to the legs of the Generator (see illustration). This is to catch the drippings from the Coil, which many persons suppose come from a leak, when in fact they are produced by condensation. This condensation caused by the hot flame coming in contact with the coil filled with cold water.

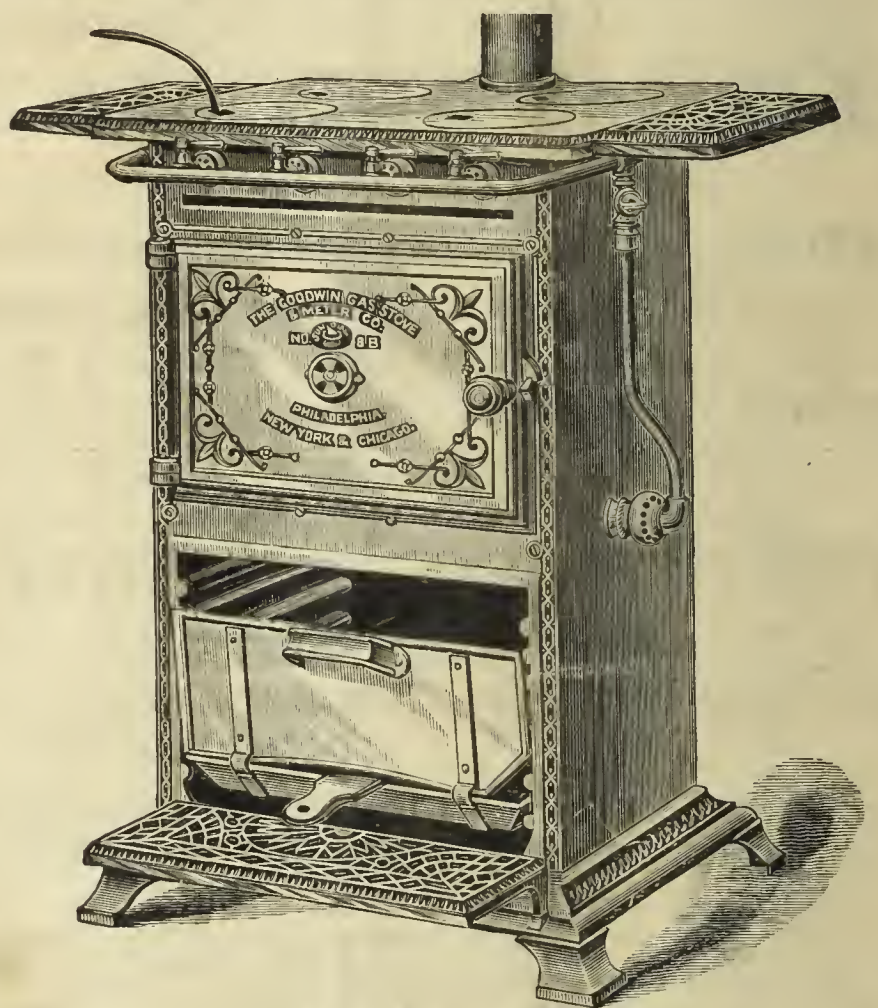

II.—Gas Cooking Stove No. 8 B.

New Style Gas Cooking Stove.

Cut II. represents our New Style Cooking Stove. As will be seen, it has an ornamented cast iron base and front, and extension shelves. The oven burner, which is atmospheric (unless otherwise ordered), is of an entirely new and improved pattern (patent applied for). The ovens are of greater capacity than those of the old style. The top, in conjunction with the outlet pipe, is designed to carry off all products of combustion; hence the outlet pipe must be connected with a flue, or the stove will not work properly.

This Stove has 4 boiling burners in top of hot plate. All fittings are nickel plated. We making this style of Cooking Stove in the following sizes—viz., No. 7 B, No. 8 B, No. 9 B, No. 10 B.

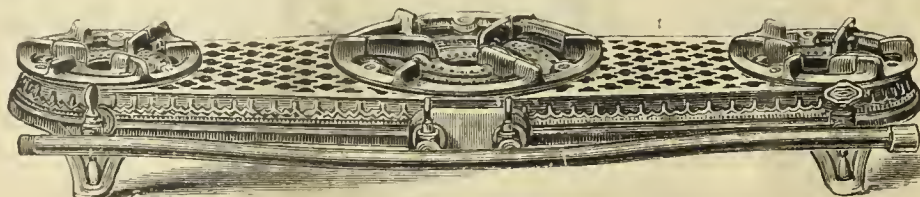

III.—Improved Hot Plate, No. 108.

New Style Hot Plates.

Cut III. represents our New Style of Hot Plates, of which we are making No. 106 (two small boiling burners), No. 107 (two medium sized boiling burners), and No. 108 (two medium and one large boiling burner). See new Catalogue and Price List for further particulars.

THE AMERICAN

GAS LIGHT JOURNAL

PUBLISHING OFFICE NO. 42 PINE STREET

DEVOTED TO THE INTERESTS OF ILLUMINATION, VENTILATION, WATER SUPPLY AND DISTRIBUTION, & GENERAL SCIENCE.

VOLUME XLVII.—No. 12.
Whole No. 684.

NEW YORK, FRIDAY, DECEMBER 16, 1887.

\$3 PER ANNUM,
IN ADVANCE.

A. M. CALLENDER & CO., Proprietors. C. E. SANDERSON, Manager.
JOS. R. THOMAS, C.E., Editor. T. J. CUNNINGHAM, Asst. Editor.

ENTERED AT THE POST OFFICE AT NEW YORK, N. Y.
AS SECOND CLASS MATTER.

Published on the 2d and 16th of each month, at No. 42 Pine Street, N. Y.

Terms of Subscription, Including Postage.—For the United States and Canada, \$3 per annum. European countries, \$3.50 (15 shillings—18 francs). All payments to be made in advance. Single copies, 15 cents.

Remittances should be made either by post-office order, registered letter, or bank draft on New York, payable to the order of A. M. Callender & Co.

Correspondence.—Wishing to make this JOURNAL a gazette of intelligent discussion to those of our readers who may wish to gain or give information on the subjects to which its columns are devoted, correspondence is solicited for publication from all who make the study of those subjects a pleasure or a profession.

The American News Company, Nos. 39 and 41 Chambers street, New York, are agents for this JOURNAL. Newsdealers will send orders to them.

Collections are invariably made directly from this office, for subscriptions, advertisements, etc. We have agents to solicit the same, but they are not authorized to receipt for money.

Books.—We will forward by express, at publisher's lowest rates, any book—scientific or otherwise—to any address in the United States or Canada. No books will be sent C. O. D.

CONTENTS.

An Asterisk (*) denotes an illustrated article.

EDITORIALS—

The Fuel Gas Question.....	385
Not Quite So Glittering.....	386
Briefly Told.....	386
Death of Duncau Campbell—The Gas Works of British Columbia—Public Lighting, Plainfield, N. J.—Cost of a Day's Fog Londoners.	
*A Regenerator Tar Furnace, by J. Somerville.....	387
The Effects of Freezing on Cement Mortar.....	390
How Shall Railroad Cars be Heated?.....	391
*Utilization of Gas Tar.....	392
The Results of the Lighting Test at the Grand Central Railway Depot, Cincinnati, Ohio.....	392
ITEMS OF INTEREST FROM VARIOUS LOCALITIES.....	394
Public Lighting, Elizabeth, N. J.—Public Lighting, Jacksonville, Ills.—How the Inspector Explained It—Killed by the Current—Cheaper Gas for Big Rapids, Mich.—Explaining a Change—Another Change—Cupid's Capture at Aurora, Ills.—Public Lighting, Red Bank, N. J.—Lima (O.) Complains—Public Lighting, Cleveland, Ohio—Down Goes the Rahway (N. J.) Schedule—To Go into the Electric Lighting Business—Annual Election, St. Louis (Mo.) Gas Company—How the Strikers Fared—Agreeing on the Price—Reorganized—What was Accomplished by Them—Gas Coal for the Philadelphia Works—Cheaper Gas for Holyoke, Mass.	
The Conservation of energy.....	397
The Market for Gas Securities	398

THE FUEL GAS QUESTION.

Mr. Edwin Squire, writing from Oil City, Pa., under date of Dec. 9, communicates the following in respect of the fuel gas agitation :

To the Editor AMERICAN GAS LIGHT JOURNAL:—May I ask room in your valuable JOURNAL for a few words on the fuel gas question?

Referring to the communication from Mr. Emerson McMillin, which appeared in the JOURNAL for Dec. 2, I must say that some of the reasons therein given why fuel gas should be made are not conclusive. Mr. McMillin says :

“First.—The loss by leakage is a much more serious one with coal gas than with a gas costing less per thousand feet. Second.—The public cannot be induced generally to adopt a high-priced gas for fuel.”

Now, if these objections to the use of gas of high calorific value are valid, why not mix 440 feet of coal gas with 560 feet of air to make a gas having about the same heating value per unit volume as the gas proposed by Mr. McMillin? Its cost in the holder would be about $\frac{440 \times 20}{1000}$

= 8.80 cents per thousand cubic feet for the former, as against 9.97 cents per thousand for the latter, the price of coal being \$2 per ton.

Probably most gas managers would object to the increased cost of street mains required to distribute the greater volume of gas and air, and the public would be likely to imagine that something was wrong with the meter, or the gas company, when the bills came around, whether the price was 30 or 60 cents per thousand cubic feet.

While it is true, no doubt, that good coal gas, pure and simple, has hitherto been found too expensive for general use as fuel, nevertheless some of the reasons why it should be preferred as fuel to the proposed mixture are :

First.—Less cost per heat unit in the holder.

Second.—Much less size, with consequent lower cost, of distributing mains and holder capacity.

Third.—The same mains could be used for delivering both heating and illuminating—or, in other words, the same gas could be used for both fuel and light.

Fourth.—The large amount (31.18 per cent.) of carbonic oxide in the proposed mixed gas would lead to a well-founded prejudice against its use.

[While we do not at present propose to enter into a critical discussion of the comparative practical value and merit of any of the fuel gases now struggling for recognition as a coign of vantage wherefrom to achieve that solid commercial supremacy resulting from public favor, we nevertheless desire to reaffirm the position steadfastly maintained by us for a number of years. Granting that a cheap fuel gas for domestic use is desirable, if not necessary, the boon when secured must be unalloyed by the excessive presence of an element not only dangerous but deadly. We most heartily agree with Mr. Squire in his surmise that a fuel gas containing 31.18 per cent. of carbonic oxide would be likely to “lead to a well-founded prejudice against its use.” Were a gas of the nature proposed intended only for distribution to the firing plant, and in other departments as well, of large factories and workshops, perhaps no grave objection could be made in opposition to such supply, for the circumstances of its application and employment would mainly be governed by and be under the control of persons actively alive to the exigencies of the situation. But when it comes to the laying on to our homes of an unrestricted supply of a like heating medium, which would become at once vastly popular because of its cheapness, utility and convenience, the case assumes a decidedly different phase. The overseer of the kitchen and the furnace differs considerably, in aptitude and resource, from the

trained fireman or mechanic of the factory or workshop. But it is hardly necessary to here enlarge on this feature of the situation. The proof of our position is at hand, but no specific publication of it is deemed necessary by us—at least at the present time, because similar facts may be gathered by those who would care to possess them. Triflers may sneer and sceptics may scoff at what is here said without prejudice or passion, but the cold facts can chill the one and congeal the other. If, then, despite the shields and safeguards (principally instituted through economical motives alone) surrounding the user of gas for illumination, fatalities are of almost daily occurrence, how greatly will the degree of danger be augmented when fuel gas shall have gained ascendancy over solid fuel provided the gaseous fuel contains an abnormally high percentage of carbonic oxide? Fuel gas investigators must, as far as possible, avoid all alliance with an ingredient whose greatest potency is in the line of destruction—in the case under consideration it would eventually destroy (at any rate partially) the availability of the product of their investigations.]

NOT QUITE SO GLITTERING.

Some rather bald facts are reported elsewhere in this issue of the JOURNAL, which have reference to the trials recently made by a committee of experts appointed to determine the cost of lighting or illuminating the structure known as the Grand Central Railway Depot, Cincinnati, Ohio, by gas and by incandescent electric lamps. The results of the trial are not particularly well calculated to give ease to those electricians who are continually and vigorously pointing with pride and speaking with fervor regarding the claims of incandescence illumination in point of the economy and superiority of their pet over gas. On the other hand, the Cincinnati verdict will not disturb other and different apostles of incandescence, their usual quiet being unbroken because of their early and well-formed conviction that, while glow lamps would quite likely find favor with the rich, gas was certain to enjoy a lengthy reign, because it was content to court the favor and patronage of the poor man. If we mistake not no less an agent than Wizard Edison himself is to be credited with the authorship of the rich vs. poor allotment of the possible commercial relations to exist between incandescence lamps and carburated hydrogen; and, furthermore, Mr. Edison emitted his famous judgment on the question quite a while ago. Knowing all about the matter, as he did, we must pay heed to and give him credit no less for his sharpness than for his candor. In further proof of his convictions on the question—that is, if the talk of the day may be accepted as affording a safe line for analyzing the fact of to-morrow—we believe the Edison Company is about to take a new departure in the process of endeavoring to popularize and localize the Edison system of lighting. It is proposed now, instead of organizing independent local Edison Companies in towns or cities where a gas supply has been laid on, to favor the combination plan; in other words, instead of antagonizing the gas men the Company proposes to sell them Edison plants. In the shout, hurrah, and glitter which accompanied the initial suggestion that gas suppliers generally should also turn current suppliers, it is just possible that too much was taken for granted, especially in connection with lighting by incandescence. The poor man is a much more important specimen in any community than is his luckier brother the rich man, which paradox is readily explained when the greater frequency with which the former type is encountered is remembered. Leaving aside the arc lighting reason why the combination plan should be favorably regarded, and it is seemingly irrefutable that the arc street light is with us for good, it appears to us, and in more pronounced manner than ever, that the fostering by the gas maker of an incandescent electric lighting plant depends solely upon the expediency of such action. We are of the opinion, too, that the inexpedients are in a large majority; and that many now on the fence will find it convenient to remain astride of the timber for a while longer, or else to descend again upon the surface of the pasture which has been green to their eyes for many a day. The Cincinnati trial affords a notable addition to the testimony already given in support of the Edisonian rich vs. poor presentment of the case—and most all artificial light users seem to feel the grind of poverty when it comes to pay the bills incurred in the illumination of their homes.

Briefly Told.

DEATH OF DUNCAN CAMPBELL.—Duncan Campbell, who over a quarter of a century ago entered the service of the Providence (R. I.) Gas Company, died at his residence in that city on the afternoon of December 7th. Deceased, although not connected with the profession in an engineering capacity, was well known to the Eastern fraternity, by

whom he was greatly esteemed. In 1861 he entered the offices of the Providence Company to undertake the duties of a subordinate clerk, and so well did he carry out the instructions of his superiors that rapid promotions shortly placed him in the responsible position of chief office clerk. Faithful and responsible, the Company, in his death, loses a valued officer. Deceased was a prominent figure in Rhode Island Masonic circles, and would shortly have completed the 45th year of an exceedingly harmonious and blameless life.

THE GAS WORKS OF BRITISH COLUMBIA.—Through the courtesy of G. L. Milne, M. D., who worthily fills the responsible post of Health Officer for the city of Victoria, British Columbia, we are enabled to present the following notes concerning the gas development in progress in that province. The Doctor says: "The New Westminster Gas Company began operations in that city over a year ago. A large plant was constructed, in fact the work was prosecuted on a scale sufficiently large to provide a supply of gas for a city having twice the present population of New Westminster. The Company has the contract for lighting the streets for the period of 5 years, and the citizens are granting it a hearty patronage. The works cost \$75,000, and the net selling price for gas is \$3 per thousand cubic feet. Nanaimo, otherwise known as the 'Diamond City' of the Pacific Coast, is now lighted with gas, the Nanaimo Gas Company having commenced operations there towards the close of 1886. Its proprietors have secured great encouragement from the citizens. The works are of the substantial sort and modern in design. This Company is also the possessor of a 5-year contract for the public lighting of the city. The coal carbonized is from the Nanaimo mines, large quantities of which are annually shipped to Oregon, Washington Territory, California, etc. It yields quite a handsome return per ton carbonized. The Vancouver Gas Company's plant has just been completed. Vancouver is the terminus on the Pacific Coast of the Canadian Pacific Railway, and is a remarkably progressive city, considering its age. It now can boast of both gas and electricity for lighting purposes, both systems being granted a healthy patronage. The gas plant just completed is the most perfect one on the Pacific Coast, north of San Francisco, and was put in with the intention of ultimately supplying gas to a large and populous city. Vancouver's advance in trade activity during the year about to terminate is nothing short of remarkable, and the Directors of the Gas Company evidently have ample reason for every confidence in the future of Vancouver. The works cost in the neighborhood of \$100,000. The net selling rate to ordinary consumers is \$3 per thousand cubic feet.

PUBLIC LIGHTING, PLAINFIELD, N. J.—The Plainfield authorities have awarded a contract for the public lighting to the Westinghouse Electric Company, the same to run for one year. The Company is to supply incandescent lamps—arc lights were formerly used, but on account of the great number of shade trees the illumination was very imperfect—to be mounted on poles 10 feet in height, lights to burn all night and every night. The price agreed upon was \$14.60 per lamp in what is known as the gas district; for 1,000 feet outside that district the service is to cost \$17.50 per lamp; while outside the 1,000-foot limit a "special rate" is to be charged. The Gas Company did not make any bid. For the North Plainfield district the contract was given to the New York and New Jersey Globe Lighting Company, whose owners are to receive \$17.75 per lamp (naphtha), on a lighting schedule of 22 nights each month. The contractors are to light, extinguish and clean. North Plainfield (population about 2,500), and Plainfield (population about 13,000), really form one city, Green Brook being the separating line. The places, however, are in different counties.

COST OF A DAY'S FOG TO LONDONERS.—The *Metropolitan*, speaking of the dark days that happened in London towards the close of the last month, says: "Wednesday (November 26), last week, was a day of continuous fog, necessitating the extensive use of gas, and on that day the quantity of gas supplied to London by the Gas Light and Coke Company amounted to 103,664,000 cubic feet, or 35,000,000 cubic feet in excess of the quantity sent out by the same Company in the corresponding day of last year. The above excess in the supply of gas would represent the supply to a town of from 10,000 to 12,000 inhabitants for a whole year. In addition to the quantity supplied by the Company mentioned, there was supplied by the other two metropolitan companies—the South Metropolitan and Commercial—about 45,000,000 cubic feet, making a total consumption for London, on a day of fog, of nearly 150,000,000 cubic feet. Approximately the value of this gas was £21,000, of which cost from £7,000 to £8,000 was directly due to the fog. In 1885, on a day of similar fog, a great strain was put upon the companies, but it is said that the supply on Wednesday last week beats the previous highest record."

A Regenerator Tar Furnace.

By J. SOMERVILLE.

[At the last Quarterly Meeting of the Southern District Association of Gas Engineers and Managers, held in London, Eng., on Thursday, Nov. 10, Mr. J. Somerville read the following paper. Our authority is the *London Journal*.]

Within the past two years there have been described and illustrated several furnaces for, and methods of, burning tar as fuel under the retorts instead of coke; and it would seem scarcely possible to have anything new to say upon the subject. As, however, our Secretary had some difficulty in obtaining a paper for this meeting, I have taken the opportunity to describe to you the arrangement for burning tar in use at the Bankside Gas Works. Probably it may be new to some of the members, and perhaps not without a certain amount of general interest just now, when tar is still a drug in the market and so low in price. I do not propose to enter into the question as to whether it is right or wrong to burn tar, as it would make this paper too long; but you may endeavor to settle that question during the discussion which I trust will ensue, as there are some of our members who hold different views on the question, and may have something to say for and against it. I will content myself by simply describing the arrangement of furnace which has been found best suited for the complete combustion of the tar, and by giving you the results of my experience of its working.

I may say that for the last seven years all the furnaces at Bankside have been of the regenerator principle; and at first a little difficulty was presented in adapting them to the burning of tar instead of hot coke drawn direct from the retorts into them, as formerly was the case. Several modifications were tried—such as using half breeze and half tar, blowing the tar into the furnace in a spray with a jet of steam, and then steam and air combined, which cut the sides and back of the furnace very much; but perhaps the greatest trouble was to get a constant, regular flow of tar without requiring much attention. Many plans and arrangements were tried and given up—some of them bad, others indifferent, and none very good; but, by keeping on trying and failing, we have at last arrived at the furnace a drawing of which you see before you, and which has now been in use for eight or nine months. Although this may not be quite perfect, it gives satisfaction; and a great consideration is that the stokers like it, and have no fault to find with it—resulting in less bad language being used about tar fires than was the case twelve months ago. Besides, we have good heats, absence of smoke, and no clinking.

You will observe that the lower part of the regenerating furnace has been filled up about half way. An arch is thrown over from side to side, on which is formed a slope from back to front of the furnace, for the coke made by the combustion of the tar to fall down. At 6 inches from the back a 14-inch arch is built; and 1½ inches above it is a 4½-inch arch carrying the tiles sloping upward to the front, and projecting some 9 inches beyond the front line of brickwork of the benches; the brickwork being corbeled outward to support the sloping furnace door and frame. The incline of the tiles is about 15 to 18 inches in 4 ft. 6 in., or about an angle of 22°. This is found to be about the right angle to set the tiles at to receive the tar, and for the tar coke formed to find its way to the lower openings where it is consumed by the two currents of heated air getting access to it through the space between the arches and the back of the furnace. As the coke produced by the tar is nearly all carbon, and (unlike coke made from coal) contains no earthy residue or ash, etc., no clinker is formed, and only hot waste dust finds its way through the openings on to the slope, and thence to the floor of the coke-hole.

The tar is passed through the furnace door direct on to the sloping tiles. A slot or opening, equal to 8 square inches in area, in the door admits sufficient air for the primary combustion of the tar; and as it inflames before it reaches the tiles, the draught carries the flame into the body of the furnace, where it meets and joins with the secondary air which enters through the nostrils in the sides and back of the furnace. This secondary air is heated in cast iron regenerating tubes laid in the bottom of the main flue beneath the retort benches. This heat, and also that from the combustion of the tar coke which is constantly forming, and as constantly being consumed at the lower level of the furnace, passes up through and among the retorts in the ordinary way to the main flue. This admission of hot secondary air greatly aids the complete combustion of the tar, and prevents the formation of smoke; so that there is little or no flame among the retorts. As the tar flows in a constant, well-regulated stream, and the coke as it is made falls down the slope to be consumed at the lower openings, and the hot dust drops out through these openings on to the bottom slope, and from there to the floor, the whole process is nearly automatic, and needs very little attention.

The tar is run into the furnace in the manner illustrated in the drawing. The store tank is situated outside the retort house, some 15 feet away. A pipe conveys the tar under the stage floor; and opposite each furnace is a smaller pipe, which takes the tar to the door, terminating in a stopcock and ½-inch bend. On the end of the bend is a plain socket, plugged with a piece of wood having a smooth hole bored through it to receive a ¾-inch brass tube, to which is soldered about a foot of ½-inch brass tube bent in the form shown—a sort of half hoop. We find this bent tube answers better than if it was straight. The end of the tube comes to within an inch or so of the opening in the door of the furnace; so that the foreman or attendant can see as he passes that the tar is running properly. The tap is turned full on, and the tar delivered by the ¼-inch tube keeps the furnace going with a very intense heat without in-

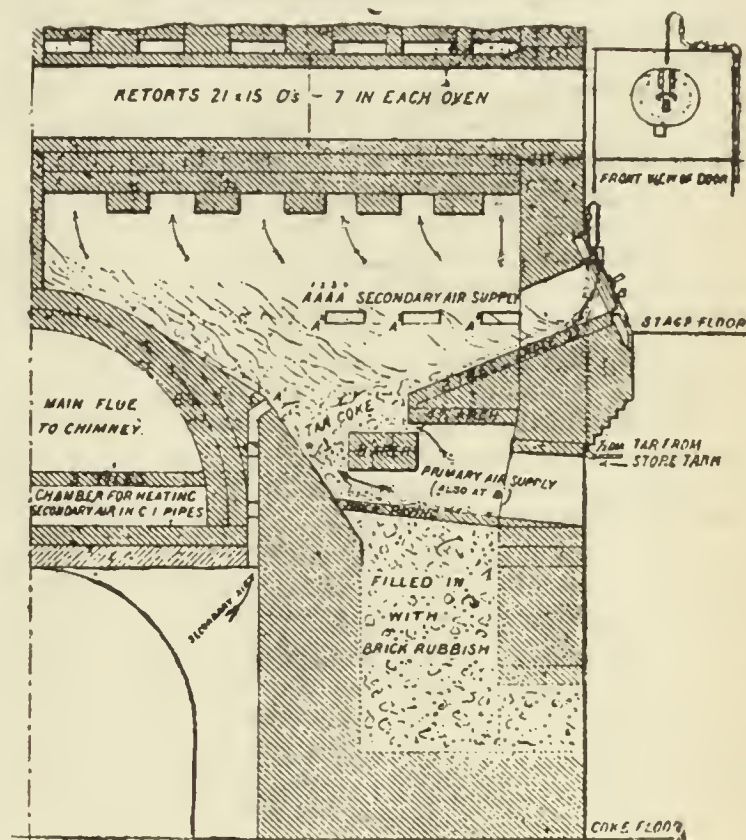

terruption. The tar is not filtered in any way. At first it was filtered by gauze screens and perforated zinc plates in a box; but this was a constant source of annoyance and trouble, and was given up, as we found it was unnecessary, and the tar is now allowed to come direct from the tank, having about 8 or 10 feet head. In cold weather the pipe is covered with sawdust, and a steam pipe laid alongside it from the tank to the retort house keeps the tar thin. In this manner we use up the whole of our tar, and have not sold any for a long period.

I have from time to time measured, estimated, and compared the quantity of tar used in these furnaces with the coke formerly consumed in them; and I find it generally works out to something like 24 gallons of tar per ton of coals carbonized—being about equal to 245 lbs. of tar. The coke previously used was 2½ cwt., or 280 lbs., for the regenerating furnaces. As we sell coke at 8d. per cwt., and tar at ½d. per gallon, the saving in our case is about 8d. per ton of coals carbonized. But the benefit is greater to those who use the common furnace, as they usually consume about 3½ cwt., or 392 lbs., of coke per ton, as compared with 245 lbs. of tar, or a saving in favor of tar of 1.4d per ton of coals, where only ½d. per gallon can be obtained for the tar. Each bench of seven retorts carbonizes about 7 tons 10 cwt. of coals per 24 hours; and about 180 gallons of tar is consumed in the two furnaces, at the rate of rather more than 3½ gallons per hour per furnace.

It has been stated, and some people still believe it, that by using tar as fuel the value of it is not raised. Let us see. In one bench of seven retorts, heated by tar as stated, 7 tons 10 cwt. of coals are carbonized every 24 hours. The quantity of coke not used for fuel is 2½ cwt. per ton of coals carbonized, equal to 20 cwt. for the 7 tons 10 cwt. of coals; and this is sold at 8d. per cwt., equal to 13s. 4d. money value. We use 180 gallons of tar as fuel instead, which, at ½d. per gallon, amounts to 7s. 6d.—being a saving in every bench so heated per 24 hours of 5s. 10d.; or, dividing the 13s. 4d. by 180 gallons, the value is raised from 0.5d. to 0.88d. In common furnaces (non-regenerators) 3½ cwt., or about 25 per cent., of the coke made would be saved; being equal to 26 cwt. per bench. This at 8d. per cwt. would realize 17s. 4d.; showing a saving in every bench of 9s 10d. per day, and raising the value of the 180 gallons of tar from 0.5d. to 1.15d. per gallon. Surely, when coke is in good de-

mand and tar a drug at any gas works, it must be economy to burn the tar under the retorts and sell the coke thus saved.

These furnaces being on the regenerating principle, and so already provided with a secondary air supply, and situated in a stage retort house, it may be said that the arrangement could hardly be adopted for common furnaces in ground-floor retort houses. But by deepening the ashpit about 9 or 12 inches, occasionally removing the dust made from the tar coke with a pan-shovel, and laying on the furnace bars fire-tiles sloping toward the back, and getting a secondary air supply from the ashpit by recesses made in the sides and back of the furnace to nostrils 12 inches or so above the slope, this would overcome the difficulty of adapting them to existing retort benches.

The secondary air supply I consider very necessary and essential for the complete combustion of the tar, which is then consumed without the production of smoke. By employing only half measures—such as using half tar and half coke in the same furnace—it is not economical, and does not always prevent the formation of smoke; and it seems very much like burning tar to get rid of it anyhow. But when tar has to be used as fuel, it may as well be consumed properly, with some regard to economy, and without producing thick clouds of smoke.

I said I would not say anything about the policy of burning tar as fuel; but I can scarcely conclude this brief paper without remarking that there may be two ways of looking at the question. And I confess I have some sympathy with those who take the sentimental view of the matter; for it does seem a great shame that in this latter part of the nineteenth century we should be compelled to utterly destroy the source of so much that is beautiful, useful, and ornamental, and which has been the very *El Dorado* of chemists both at home and abroad for the last quarter of a century, and a waste material upon which has been lavished more thought, pains, and experiment, by men of great genius, than upon any other waste product one can mention. It is the raw material also from which is manufactured the thousand and one articles you have seen enumerated on those wonderful tar trees, especially the last issued by Mr. Benjamin Nickels, F.C.S., graphically colored with all the hues of the rainbow, representing the beautiful products obtained from the common black tar, and tabulated with such fearful-looking names—regular tongue-twisters—any one of which would puzzle a Welshman to pronounce without stopping to take breath. I say it does seem a pity that this valuable commodity should be put to so base a use; but then comes the other view of the matter—the commercial aspect of the question. If all further invention is hopeless, if all genius in regard to finding out other rarities and novelties is lying dormant for a season, and no Samson arises to the occasion and gives us deliverance—and there never was a finer opening or better opportunity for the rising chemist or man of science to show the way out of the difficulty—till this is done, and a better use can be pointed out, I am afraid that we must continue to burn it. What, for instance, is to be done in the following case: The manager of a good-sized country gas works, which are situated in the center of the country away from any water transit, has eight or ten benches of retorts, and he has to cart his tar to the railway station, and there pump it into tank trucks to go some 30 or 40 miles to the tar distillery. He came to see me at Bankside some months ago, to learn how we burned our tar. He told me that the contractor absolutely refused to take his tar, and would not renew the contract at any price, as the cost of railway carriage was double the value of the tar. As he had a good sale for all his coke at a fair price, he asked me what was best for him to do. Now what was that man to do with his tar? I told him he had done the best thing he could under the circumstances, and that the way in which it could be best utilized in the retort furnaces was as he saw it before him; and I advised him to go home and do likewise, which he did.

[Mr. Somerville added that since he wrote his paper, about three weeks ago, a paper* had appeared by Mr. C. H. Nettleton, of Birmingham, U. S. A. It was a very able contribution to the subject of gas works residuals, and well worth reading. It appeared that in America they obtained \$2.50 per barrel for their tar, each barrel holding about 50 gallons. This worked out to about 2d. per gallon. In conclusion Mr. Somerville quoted the last paragraph of the section of Mr. Nettleton's paper in which he dealt with the subject of "tar."]

Discussion.

The President said that Mr. Somerville had put before the members some useful suggestions as to burning tar, which might be adopted by those who were in charge of works sufficiently large to allow of regenerator furnaces being used. This was a condition of things under which he (the President) had not been able to work at present, as his place was

very small. He had tried to use tar, and was successful as far as actually burning it went—regulating the supply to the furnaces, and getting good combustion; but he did not obtain such good heats as he had previously done with coke fires. He hoped in the discussion they might be able to add something to their knowledge on this matter, because there was not the slightest doubt that they would be compelled to go on using tar in this way for some considerable time to come. At his works they could only dispose of the tar in small quantities, for paving and other minor purposes. The tar distillers were too far away to make it worth while for him to send the tar to them, because by the time they had deposited it at the distillery it hardly returned them anything. Under the circumstances, all he could do was to give his attention to the proper and best means of utilizing it as fuel.

Mr. C. Gandon (Lower Sydenham) remarked that he did not think he could add very much to what Mr. Somerville stated in his paper, except that he might say he had had considerable experience in burning tar. In October, last year, he began to use tar on the works of which he was at present in charge; and in doing so was helped by his former experience of it. The conclusion at which he had arrived was that to burn tar successfully—he was not referring to regenerator, but to ordinary furnaces—it was necessary to have a large combustion chamber; in fact, a bench of seven retorts, with the central one over the furnace arch, was an unsuitable erection for burning tar properly. He illustrated this last summer by using tar in a furnace with seven retorts, and he very soon succeeded in burning out the middle retort. They then started twelve furnaces, heating six retorts in each, the middle retort being left out. They thereby obtained a large combustion chamber. These were in operation, he remembered, from October last year until June this year without intermission, and they worked very satisfactorily. The reason they were stopped was because they needed some repairs. They found that the retorts were very little damaged indeed. One or two of the arches—they were Gothic arches—had burnt down; the other ones being as good as when they first started. He could entirely confirm Mr. Somerville's statement as to there being a very small amount of clinker formed. Very little clinkering required to be done in the furnaces, and therefore the sides were not so likely to be destroyed as they were when burning coke. As he had said, they had only used ordinary furnaces at his works; and they had a very simple way of introducing the tar into them. They had a tank in the coal store adjoining the retort house, and the tar ran from it by pipes to the latter. On the pipe supplying each furnace they had a tap, on which was a cock, with a small piece of twig passing up, which was pushed up now and then to keep the tar running. The only difficulty they found was that the men would not look after the fires sufficiently well to prevent smoke occasionally issuing from the chimney. He should be glad if Mr. Somerville or anyone else would tell them how to make it impossible for smoke to come out of the chimney. His experience was that they used about 100 gallons of tar per furnace per 24 hours; and he understood Mr. Somerville that he burned 90 gallons; so they did not differ very much. As they could only obtain 3d. per gallon for the tar, he considered it best to burn it; but he should be pleased to be able to get such a price for it as would render it unnecessary to do so. So long as a sufficient price could not be obtained for the tar, he should, notwithstanding the beautiful colors to which Mr. Somerville had alluded, advise gas managers to burn it. He should like to ask the author of the paper whether he had not rather over-estimated the relative value of tar, when he took the value of coke at 8d. per cwt. at Bankside.

Mr. F. Livesey observed that he was unfortunately absent when Mr. Somerville read his paper; but he had had some conversation with him as to the origin of this furnace, and he (Mr. Livesey) would like to explain it. The Rotherhithe works of the South Metropolitan Gas Company were managed at one time by the late Mr. Croll, and Mr. G. Anderson was there. The latter gentleman, he believed, left in charge of a bricklayer—a very old man now—a drawing of a furnace. It was true that this furnace was not adapted for a stage retort house; but it was a furnace that had a slot in it, and an inclined slope on which the tar was spurted, and air was admitted at the back. This was the main principle of the furnace which Mr. Somerville had described. There was a difficulty in a floor house to probe away the dust from the back of the furnace. On seeing the drawing he referred to, he had the furnace tried at Rotherhithe; but it did not succeed. They made another trial at the Old Kent Road; and there it answered very well—indeed, so much so that he mentioned it to all their managers, and suggested that they should try it at the different works. Mr. Somerville had this advantage—that he had secondary air admitted to his furnace, which was just the thing required to make it a complete success. In burning tar there was a great deal of difficulty in keeping down the smoke.

* See JOURNAL, NOV. 2, 1887, p. 279.

There was a sort of pitchy mass accumulated where the tar dropped. A man would go in with a rake or other tool and stir it up, and then they had a tremendous volume of smoke from the chimney. By admitting the secondary air, however, this difficulty was entirely surmounted; and with proper management there need never be any smoke at all. It was not necessary to have any elaborate system of heating the air, and it was very certain that all they required was an air supply on the top of the fuel. It was important that the combustion of the tar should take place not immediately between the two bottom retorts, but, if possible, lower down, as might be managed in a stage retort house. The only place where this furnace burnt away was at the back, where the air was admitted. This need not occur if it was always kept full of its tar fuel. The proper way to burn tar was to use tar only, and then they could very readily find out what they were doing. When tar and coke were consumed together, they were absolutely in the dark as to what they were about. When tar was employed alone, they had only to measure it day by day to ascertain precisely how they stood; they knew the price of the tar and the value of the coke. With respect to the flowing of the tar, Mr. Somerville introduced a very great improvement in the furnace. By the means he adopted he allowed the tar to flow from his pipes direct into the furnace on to the fuel. The best way to regulate tar was to have a long tube, or a spiral tube, which could be easily taken in and out, and was very little trouble indeed. The tar would never stop flowing if it was properly strained. He (Mr. Livesey) rather liked the bent tube. He preferred the bent tube coming out of a T, for if there was anything in the tar it collected in the bottom part of the T. He thought Mr. Somerville had worked very hard at this furnace, and had certainly improved it; but he should like it placed on record that something was due to Mr. Anderson, as it was first brought out by him.

Mr. C. C. Carpenter observed, as the result of his experience with various forms of tar furnaces, that it was very necessary to have a secondary air supply to the furnace, and equally necessary that it should be heated; but to do this effectually did not demand an arrangement of properly-constructed air-heating flues, where these did not already exist. They had at the Vauxhall Gas Works twelve tar furnaces applied to the ordinary settings, constructed with a front chamber similar to those described in his (Mr. Carpenter's) paper read before the Association last year. Through this chamber a 3 inch pipe was built conveying air, which thus became heated in its passage into the combustion chamber of the furnace. This arrangement almost wholly prevented the formation of smoke, which it was not possible to do when cold air was admitted at the furnace door. With reference to the regulation of the flow of tar, they used the straight brass tubes as described by Mr. Frank Livesey, and nothing could exceed the simplicity of the arrangement, nor the perfect control it permitted over the supply to the furnace without the slightest attention.

Mr. W. H. Broadberry (Tottenham) said the furnace he used was very much like the one which had been described. They had no iron chute at all, but simply ran the tar direct upon the fuel. He had some difficulty in having a very small combustion chamber; and he found it almost impossible to get rid of the smoke. While he was personally in the retort house they could manage to get along very well without much smoke; but when he left it in the hands of the stokers a large volume of smoke was soon seen issuing from the chimney. Stokers seemed to have the idea that the furnaces were erected purposely for consuming tar; and as long as they got as large a quantity of tar into the furnace as was possible, they considered they were doing as much as could be expected of them. With his setting of eight retorts he was burning about 5 gallons of tar per hour; and comparing the cost of tar and coke he found that the tar at $\frac{3}{4}$ d. per gallon about equaled coke at 6d. He must confirm what had been said as to the condition of the furnaces in which tar was used. When he let down the furnaces at his works they were in almost as good a state as when they lit them up. As to cost, he could not at all compare with Mr. Somerville's figures; but next winter he might be able to do better.

Mr. D. Ford Goddard (Ipswich) said there could be no doubt that the burning of tar had gone far beyond the mere experimental stage. That it could be burnt had now been proved again and again; but whether it could be done to show real economy was quite another matter altogether. History said that at Ipswich, many years ago, there were built several of Mr. Anderson's tar furnaces; and history also recorded the efficiency of these furnaces—at least as regards heat, because he understood that the retort setting came down upon the top of the furnace as the result of the enormously high temperature. Now, with the experience he had had with burning tar, he certainly could not complain of want of heat, although he had never had the opportunity of using regenerator furnaces. He had simply had ordinary furnaces with the middle retort left out—

six retorts in a bed—which gave considerable capacity for a combustion chamber. He had no difficulty in getting sufficient heat; the trouble was to regulate it. When he began to burn tar (he thought it was last year) the calculation he made was that if they could not sell tar for 1d. per gallon it would answer their purpose to burn it. But subsequent calculations, based upon real working of the furnaces, showed that this was too high a figure; and he immediately came to the conclusion that if they could get $\frac{1}{2}$ d. per gallon it was better to sell than to burn it. With regard to smoke, he said he could not conceive of any method of burning tar in which they could completely do away with the smoke nuisance. Whether or not this was a nuisance that stood in the way of the utilization of liquid fuel, he was not prepared to say. There was no doubt that the use of tar caused considerable inconvenience, and entailed trouble in watching—seeing that the furnaces did not become too highly heated, and that there was no destruction going on in the furnace. The inconvenience of having constantly to watch was, he supposed, really the reason why it was becoming the prevalent habit to do away with tar burning.

Mr. J. L. Chapman (Harrow) remarked that the question of tar firing was one of considerable interest. He had tried it and had found the same results as many others—that the retorts were destroyed in the furnace. They had splendid heats, and obtained higher results per mouth-piece than they ever had before, and a better return per ton of coal carbonized. But afterwards they found that the bottom retorts and the middle one were very much shaken, and pieces were constantly dropping out. The heat was sometimes so great that the retorts would run and stop the flues; and in the case of one bench especially, they were not able to use the retorts again. This tar question was one of great difficulty for small gas works. In such works a man would come and pump up the tar and take it away; and they were very glad indeed to see the back of him and get the tar out of the works. When they had always before them this constant tar pumping, with more or less muck connected with it, he thought that many of them, for the sake of a shilling or so, would rather see the back of it. He (Mr. Chapman) was in a position that made it absolutely necessary to burn his tar. He was two miles from water carriage, and ten or eleven miles from London; and therefore he was compelled to utilize it. In the course of a conversation on the subject with a gentleman he mentioned that he had seen a tar injector in Vienna, the invention of Mr. Drory, which might be of service to him (Mr. Chapman). He procured one and applied it to the boilers, and he must say he was extremely satisfied with the result, both from a monetary point of view, and as requiring less attention than anything he had tried before. It was a peculiar thing that as soon as they commenced burning tar their coke began to accumulate, and it had gone down in price something like 3s. or 4s. per chaldron.

Mr. P. Thomas (Ware) said he would like to give the meeting his simple experience of tar firing at a country gas works. He had adopted this plan of heating his furnaces; but was working under difficulties. He would rather that his middle retort would burn away, and then he would have a larger combustion chamber, which would prevent the smoke. The result was that he had to use a portion of coke to avoid this. He had a regulator by which he could pass the required amount of tar into the furnace. He burned a little more than a gallon per hour; and in a setting of seven retorts he used 3 cwt. of coke. There was sometimes a complaint of smoke; but he could see this from his own house, and could have it altered directly, and it caused no trouble at all to do this. The arrangement he employed was very simple, and he was able to get a yield of 10,000 cubic feet of gas from a ton of East Poutop coal, which he thought was practical working. He mentioned that he obtained 8d. per cwt. for his coke.

The President said he was pleased to find, from the discussion, that so many gentlemen had been successful in the matter of tar firing. They had had various appliances described, and most of the members had spoken of having obtained good heats; but he (the President) had not yet learned how this was accomplished. As this was his one trouble, he would briefly describe the setting he used; and if Mr. Somerville, in the course of his reply, could help him out of his difficulty he should be glad. He commenced by using tar with a sort of intermittent coke fire. He could not get on with the system, and so gave it up, and adopted a style of furnace exactly similar to that shown in the drawing which Mr. Somerville had exhibited, with the exception that the air was not heated, but simply drawn in at the back of the furnace, and a slight portion at the very front where the tar was admitted. He had the same style of tar regulator, and tiles on which the tar trickled down; and he could regulate the tar exactly as it was wanted. His retorts were 15-inch circulars, and the bed was 6 ft. 6 in. wide and 4 ft. 6 in. high. He could not obtain with tar such good heats as he formerly did with coke.

Mr. Somerville, replying on the discussion, said he was much obliged for the criticism of his paper. As to Mr. Gandon's remark about the figure he quoted for coke, 8d. was the price in the yard at the time he wrote the paper. With respect to Mr. Livesey's observations as to the originator of the furnace, there was no doubt that Mr. Anderson did make a very good furnace years ago; but there was no reason why it should not be improved upon. Although there was a sloping tile, etc., the furnace he had described was essentially different from Mr. Anderson's. Anyone who came to look at his drawing and then at Mr. Anderson's would see that there was not the slightest resemblance. He did not wish to take away from Mr. Anderson or any other inventor what was due to him; and he believed that Mr. Anderson's method was one of the best. This was the arrangement with which they commenced; and, in the course of working, one thing suggested another. The main feature of the furnace he had described was the secondary air supply, which effected the complete combustion of the tar. This was the whole secret of the furnace that he had described in the paper. [Mr. Somerville explained, by the aid of the diagram, the course of the secondary air supply.] Since first started the furnaces had been lowered 18 inches, as he found they burned the edges of the retorts. If they had 3 ft. 6 in. in the depth of the furnace they would not have any intense heat in the bottom retort. They now had a regular heat all through, without any detriment to the middle retort. With Mr. Livesey's other remarks about using half tar and half coke, he quite agreed; it was impossible to know what one was doing when half one and half the other fuel was employed. He formerly used, as Mr. Livesey had described it, a T; but it was Mr. Geo. Livesey who made the suggestion to do away with it. He explained its object to him, but he could not quite see it; and so he (Mr. Somerville) tried the bend. Therefore this was Mr. George Livesey's part of the arrangement; and this was the reason for the departure from the T. He thought he had answered Mr. Goddard about lowering the source of heat just about a foot, so as to get 3 ft. 6 in., which would protect the retorts from injury. Mr. Thomas was doing very well—rather better, in fact, than most managers. He had, however, the same trouble with smoke, and he could only prevent it by introducing secondary air. This, as he had said, was the secret of thorough combustion. As to their President's inquiry, he (Mr. Somerville) would suggest that the way to overcome his difficulty would be to make three recesses of 2½ by 9 inches in each side of his furnace, and then he would be certain to get thorough combustion.

The Effect of Freezing on Cement-Mortar.

Something over a year ago Alfred Noble, C.E., read a paper on this subject before the American Society of Civil Engineers. The author said:

In the construction of a lock at the St. Mary's Falls Canal, the laying of masonry was discontinued about Oct. 20 of each year on account of the frequent recurrence of freezing weather. On the last day of the work in 1887, mortars of Portland cement and of a good quality of American natural cement were used in adjoining portions of the wall. The same proportions of cement and sand, 1 to 1, were used in both classes of mortar. This masonry was laid during a light rain. The following spring the surface of the Portland cement-mortar was sound, showing perfectly the marks of the rain drops. The natural cement-mortar was disintegrated to a depth of 3 or 4 inches.

In the same locality it was necessary to lay a concrete foundation for a movable dam in February. The weather was extremely cold, generally about zero. The mortar was made with Portland cement. Salt was used freely, but without retarding very much the freezing of the concrete. The concrete was at once covered with a floor of timber and plank, on which the masonry abutments were built. Samples of the frozen mortar set properly after being put in a warm place. There was never any settlement of the masonry, and within a few months the concrete sustained a pressure of 15 feet of water without developing any leaks.

In the construction of a bridge across the Clark's Fork of the Columbia river, in Northwestern Montana, the caissons were filled with concrete during freezing weather. Portland cement was used. The proportions of cement to sand were 1 to 3. Within a week the laying of stone masonry was commenced on these caissons, and proceeded with as rapidly as possible without apparent injury to the concrete, which had set firmly. In these cases the temperature had risen above the freezing point within two or three days after the concrete had been placed; and it had been permeated to some extent by warm air escaping through leaks from the air chamber.

Four small piers were built for the St. Louis River Bridge on the Northern Pacific Railroad, near Duluth, in the winter of 1884-5. Dur-

ing the laying of masonry for pier 1 the temperature varied from 0° to 20°; during the building of pier 2 the temperature was about 20° higher, and during the building of the remaining piers the temperature was occasionally about the freezing point. Portland cement was used throughout, the proportions of cement and sand being 1 to 1½ for face stone, and 1 to 2½ for backing. During the extremely cold weather salt was used freely in the mortar, and the sand was warmed (not made hot); but with the thermometer at 20° the mortar froze quickly after being spread on the stone—so quickly, indeed, that if the stone, being set, could not be brought to a bearing by a little shaking, it was necessary to raise the stone, scrape off the now frozen mortar, and spread a new bed. In setting the face stone the mortar was kept back from the face an inch or so to facilitate subsequent pointing. A few weeks later, after there had been milder weather, an examination of the open edges of the mortar beds showed that the mortar used during the coldest weather had set firmly, and no difference could be detected by examination of detached fragments between the mortars in piers 1 and 4; that is to say, between that laid in the coldest and that laid in the mildest weather embraced in the period of construction of these piers.

During the course of tests of cement at the St. Mary's Falls Canal, a few experiments were made relating to the effect of freezing and the use of salt on cement-mortars. They are not submitted as conclusive in any way, but as suggestive, and in the hope that, combined with others, some definite conclusion may be reached.

TABLE A.—EFFECT OF FREEZING ON MORTARS OF PORTLAND CEMENT CONTAINING VARYING AMOUNTS OF SALT.

Composition of Mortar.

Cement 35 ounces.
Water..... 7 “
Salt as in table.

Tensile Strength per Square Inch at Seven Days.

Treatment.	Salt.								
	0.	1/8 oz.	1/4 oz.	3/8 oz.	1/2 oz.	5/8 oz.	3/4 oz.	7/8 oz.	1 oz.
<i>First Series.</i>									
Immersed in test-room when removed from moulds	327	357	375	392	429	402	415	388	402
Exposed to air when removed from moulds and frozen 3 days; then immersed in test-room 4 days.....	316	378	411	374	415	405	392	383	409
<i>Second Series.</i>									
Immersed in test-room when removed from moulds	336	422	421	399	394	384	390	356	387
Exposed to air when removed from moulds and frozen 6 days; then exposed to air in test-room at 70° one day.....	169	198	167	217	227	215	208	221	239

TABLE B.—EFFECT OF MIXING SALT WITH PORTLAND CEMENT MORTAR.

Proportions by Measure.

Cement 1
Sand 1

Proportions by Weight.

Cement 21 ounces.
Salt..... 23 “
Water..... 6 “
Salt as in table.

Means of Ten Tests.

Salt.	Tensile Strength, Pounds per Square Inch.							
	7 days.	30 days	90 days	6 mos.	9 mos.	12 mos.	18 mos.	24 mos.
0	155	220	289	311	390	382	402	430
1/8 ounce	139	200	246	288	363	364	423	346
1/4 “	139	192	221	289	352	383	392	326
1 “	128	189	217	288	343	369	350	334

The following discussion ensued:

F. Collingwood—Mr. Noble said that he found the natural cements did not stand the cold so well as the artificial cements; that he always found

the natural cements to be damaged two or three or four inches from the face of the joints after they had been exposed to very severe freezing, and we found something of the same kind in our work on the East River Bridge. On any wide wall where water could collect on top and where it was exposed to the weather all through the winter, we found that we would have to scrape out the joints; but the face joints never troubled us. We used the Rosendale cements.

George S. Morison—As bearing immediately upon the subject of freezing, I might mention an incidental experiment that occurred last winter in the work on the Omaha Bridge. I had quite a number of briquettes made of American cements and imported Portland cements, which were exposed to the air 24 hours and then left in the customary way in a pail of water. There came on extremely cold weather, and the entire lot became a solid block of ice. When it thawed out the Portland cements were entirely uninjured, but the American cements were entirely ruined, some of them being reduced to mud. Subsequent experiments showed that the cements which stood freezing three days after they were made, would also stand freezing immediately after they were mixed. It has been for some years my practice to use Portland cement exclusively in places where the mortar was likely to freeze before setting.

Robert B. Stanton.—I have had some experience in laying masonry in very cold weather. In the winter of 1878 and 1879 it was found that a small pier on the Cincinnati Southern Railway, was defective. The pier was taken down and rebuilt with Louisville cement, and with the use of salt. The thermometer at the time ranged from 6° to 10° below zero. The iron trestle was put upon the pier, and during the winter no change in the masonry was noticed. When, during the next summer, it became very hot, the pier seemed to sweat; the salt came out and made the sides white, but the cement was as hard as if it had been laid in the summer, and, so far as I have since learned, there has never been any trouble with that pier. In the winter of 1881, here in Denver, in building the round-house and shops of the Union Pacific yards it became cold very suddenly. After waiting for awhile, the weather not getting more moderate, the work was proceeded with and salt was used in lime mortar, and every night the top was covered with a thick coat of salt; the mortar was not really frozen. The next summer a locomotive got away and struck this masonry between the two windows, tearing away the lower portion and leaving the whole keystone portion above suspended and held up by the mortar; and this masonry hung thus for several weeks. It is possible that the mortar did not freeze during the day, but during the night the temperature was very low.

Eliot C. Clarke—Some years ago I made a number of experimental batches of concrete, some of Rosendale cement and some of Portland cement. Of these a portion were made with a large proportion of cement, and some weaker, of each kind. I made them just before freezing weather and left them out, being engaged on work in which some concrete had to be exposed in that way. They were left for two or three years exposed, and during the first winter the Rosendale concretes without exception began to weather badly on the surface, and from year to year disintegrated; none of the Portland cement concretes were affected at all in three years, though lying right on the surface of the ground in blocks about a foot square. I remember once talking with Mr. Shanahan, who is the Superintendent of Public Works of the State of New York, about his practice on the Erie Canal, and he told me that he would as willingly build masonry in the winter as in the summer, so far as its durability was concerned. He used Rosendale cement in building masonry, a tolerably strong mortar—that is, a large proportion of cement to the sand; and always used in mixing only the strongest brine—that is, water saturated with salt so that it would foam on top. He said he never knew a case to fail built in that way.

John Bogart—I have had occasion to examine recently the masonry referred to by Mr. Clarke, built upon the line of the Erie Canal. This masonry was the retaining wall of the West Shore Railroad where it runs along the canal. Where it was first laid in very cold weather, without the proper use of salt, it gave way and got into very bad condition. Directions were then given, and carried out, for using a strong solution of salt for mixing the mortar, one barrel of brine being mixed when another was being used for mortar. The result has been very satisfactory, and the masonry is in excellent condition.

J. James R. Croes, replying to a question as to the use of salt, quoted from a paper presented by him in 1874 on the construction of a masonry dam: "In freezing weather the mortar was mixed with salt water. The rule for proportion of salt was one said to have been used in the works at Woolwich Arsenal some years ago, viz.: Dissolve 1 pound of rock salt in 18 gallons of water when the temperature is at 32° F., and add 3 ounces of salt for every 3° of lower temperature. The masonry laid

with mortar thus prepared stood well and showed no signs of having been affected by the frost.

How Shall Railroad Cars be Heated?

Mr. H. Q. Hawley, who has devoted much attention to the question of the employment of gas in domestic and industrial directions, thus discusses the heating of railroad cars:

Assuming that steam from the engine will be generally used, the matter most requiring to be tested for the solution of this problem is how to supplement steam from the engine for the time when it cannot be used, before the cars are connected with it, and when it is disabled away from terminal points. Why, then, are the tests now being made confined to the former use (requiring only a choice between several methods to find the best), while for the latter use nothing is done, although without providing for it the question cannot be settled?

As further proof of the necessity of extending the tests now being made, as above suggested, I add the following facts:

1. Relating to steam from stationary boilers: The advantage of this method is that it answers the purpose before steam from the engine is available. Its disadvantage is that it answers no other, and in answering that, requires, in case when (as at the New York terminns of the Pennsylvania road) several trains leave at the same time, or nearly so, that the track system be reorganized; and in all cases that new and costly investments shall be made at all stations when trains are made up and kept always ready for use.

2. Coal stoves and heaters, the means relied on at present for supplementary heating, are not practical for that use, as they require the fuel to be removed from them in a glowing state and after short use, and therefore are too wasteful, troublesome and dangerous for use at depots. When the engine breaks down, when a stove or heater is kept in a car for that contingency alone, there would be much delay in heating it up in time, and it would be filled with burning coal when the train began to move.

3. Assuming that neither of the methods above described for heating cars before steam from the engine is available for the purpose are practical, it follows that, so far as that operation is concerned, the car heating problem is narrowed down to the inquiry, "Can gas be used for it?" In answer to which, and as proof that I appreciate the conditions required to make the use of gas on cars practical, I here state them:

The furnace used for it must burn the gas without waste (as heat alone and not the impact of flame must be used) must be so arranged that any undiluted heat can enter its flues, as otherwise the cost of its operation would be too great. It must not require inconvenient alteration of the car. It must be supplied by gas pipes under the cars and connected between them, as steam pipes now are, so that when the gas used comes direct from street mains, all the furnaces in a train could be supplied from one connection with said main, turned on when the heating commenced, and off when the engine came.

It must not only heat the car, but be capable of heating it quickly when required for emergencies, or in extreme cold weather. And, if possible, the heater should be so constructed that it can be changed from a gas to a coal burner or back again in a few minutes and without other change than loosening a few screws, to provide for the contingency of the engine being disabled away from terminal points, and in cases when trains are made up when there is no gas. That is the case when gas is used only for heating—when it is used for both heat and light, of course, the gas in the storage tanks could be used, and the change to coal would not be needed.

Assuming that gas can be used as above stated, and the apparatus for its use so arranged that it can be taken directly from street mains while the cars are being heated up, and then shut off, so that only one heating with gas would be required for a route, however extended it may be, can any other method be safer, cheaper or more convenient? As neither storage tanks, under the cars, nor special gas works would be required, except at great cities and by trunk lines, when the use of gas, if used for both heat and light, would be so great that economy would demand its manufacture by private works.

Again, the use of mineral oils being now forbidden on cars, either gas or electricity must be used for lighting them, whatever means are used for heating them, so that the use of gas for both purposes is really the simplest method known.

I think that what I have written gives sufficient reason to show the necessity of testing gas as well as steam without further delay.

WE believe the Penn Globe Lighting Co. has been authorized by the Gloucester City (N. J.) Council to light the streets with gasoline lamps.

Utilization of Gas Tar.

Among recent English patents we note one that was granted to John Hammond, of Eastbourne, who proposes to utilize the tars produced in the manufacture of illuminating gas in accordance with a rather novel method. An abstract of the inventor's specification is appended:

The gas tar is continuously and automatically distilled, the light hydrocarbons going to enrich the coal gas, while the pitch or heavy hydrocarbons are drawn off to be burned or otherwise used. The drawings shown are intended to illustrate the manner in which it is proposed to practically apply the invention.

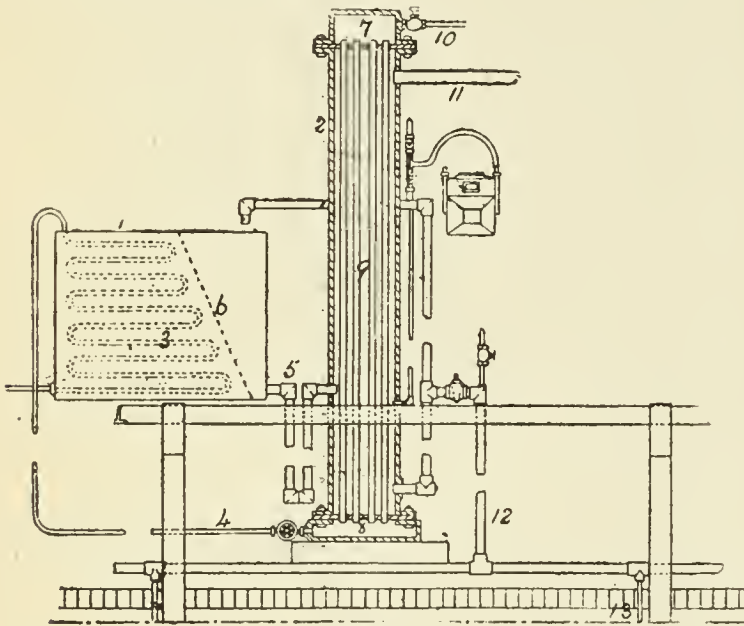

Fig. 1.

The tar is first placed in the tank, 1 (fig. 1), where it is heated by the waste heat from the still, 2, passing through the coil, 3, communication between the still and the coil being made by means of the pipe, shown at 4. From this tank the fluid tar gravitates to the still, 2, through the tube, 5. In passing from the tank, 1, it is filtered by the screen, 6, which is arranged so as to cause the arrested impurities to fall to the bottom of the tank, thus leaving the filter clear for the passage of the tar. The still, 2, is provided with chambers, 7 and 8, and tubes, 9, for the passage of high-pressure steam from the pipe, 10, to the pipe 4. The heat of this steam vaporizes the more volatile constituents of the tar in the still; and these vapors are conducted by the pipe, 11, to a refrigerator constructed like the still shown by fig. 1. In this refrigerator the naphthaline, ammonia, and light oils from the still are condensed by the passage of water, air, brine or steam through the tubes. A pipe at the bottom of the refrigerator leads the condensed naphthaline and light oils back to the retorts to be again distilled with the gas, or into the hydraulic main to mix

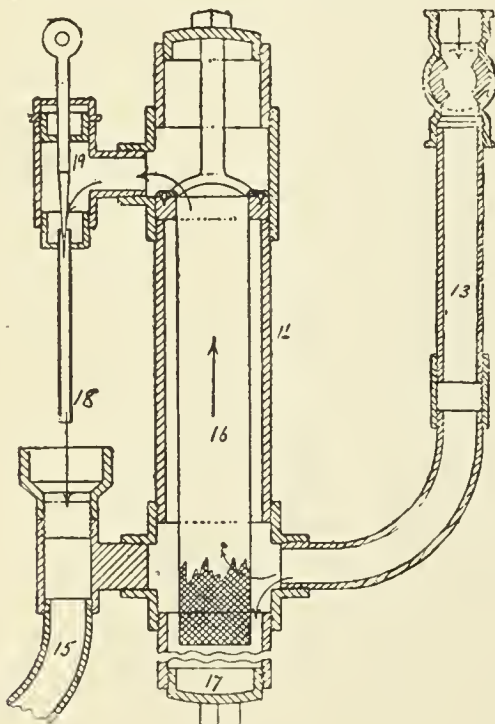

Fig. 2.

with the gas, or into a separate tank, the destination of the liquid being dependent upon the positions of certain stop-cocks upon the pipe. The heavy portions of the tar flow from the still, 2, through pipes, 12 and 13, to the fuel regulator, 14, placed at the side of the retort oven. From the

regulator, 14, the tar is carried across to the furnace, in the center of the oven, by means of the pipe shown at 15.

Figure 2 shows the regulator in section. The coarser particles of tar held back by the cylindrical sieve, 16, collect in the lower part of the regulator, and are occasionally drawn off by means of the plug, 17. The sight-feed, 18, to the pipe, 15, is regulated by the needle, 19.

The tar flowing from the pipe, 15, falls into the tar channel, 20 (fig. 3), over the firebrick arch, 21, and thus reaches the incandescent coke at 22. The furnace is supplied with heated air through the flues, 23 and 24. The balanced ashpit damper, 25, regulates the passage of heated air to the lower flues; 26 is an iron dead-plate, and 27 is a movable iron dead-plate. To keep up the temperature the various pipes are lagged with non-conducting material. A measured quantity of air heated to a temperature slightly above the temperature of the still is driven into the still by means of a steam jet to assist in the evolution of the light vapors; a steam jet may also be used to agitate the boiling tar. To withstand the intense heat developed by tar firing the furnace may be lined with a mixture of oxide of magnesia and silicate of soda, with or without a small quantity of suitable fireclay. This mixture can also be used to stop cracks

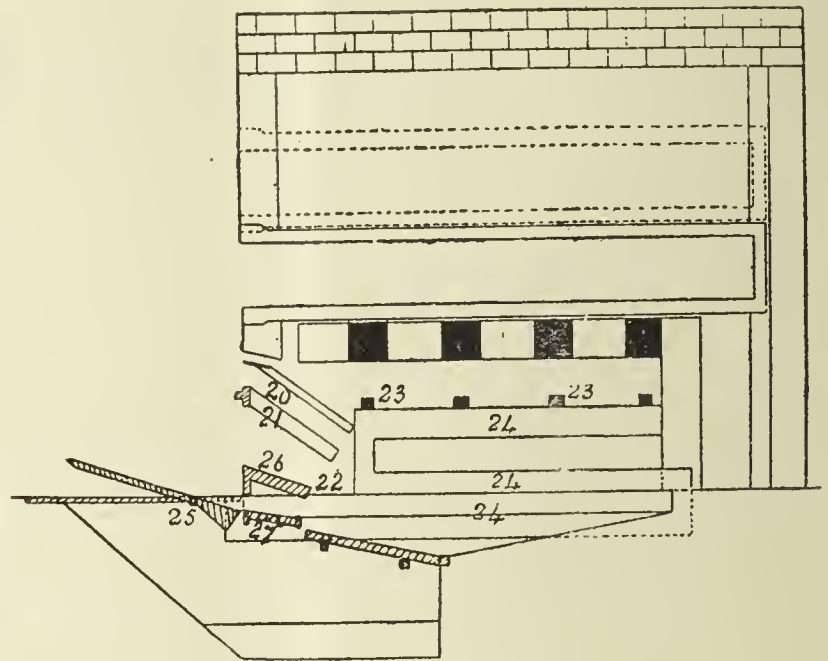

Fig. 3.

in leaky retorts; and bricks formed of a similar material can be used to withstand the cutting action developed by too close tar firing when it is not convenient to enlarge the furnace to a more suitable size for the use of liquid fuel. The vapors from the still, 2, can be passed direct to the coal gas in the hydraulic main, without passing through the refrigerator; but when this is done it is necessary to pass the gas through a lime purifier either at the inlet or the outlet of the gasholder. The gas is made to pass from top to bottom of this purifier for the prevention of naphthaline crystals in the mains, etc.

The Results of the Lighting Test at the Grand Central Railway Depot, Cincinnati, Ohio.

[Through the courtesy of Gen. Andrew Hickenlooper we are enabled to place before our readers the following summary of the report made by the experts—Messrs. J. W. Hill, M.E., Prof. Thos. French, Jr., of McMicken University, and C. E. Jones, Electrician—selected to determine the comparative cost and efficiency of gas and electricity in the lighting of the Cincinnati Grand Central Railway Depot. We preface the summary with a characteristic communication to the depot managers from the General]:

OFFICE OF CINCINNATI (O.) GAS LT. AND COKE CO.,
CINCINNATI, OHIO, Nov. 22, 1887.

To Jacob Heglin, Supt. Grand Central Depot: Dear Sir:—Jno. W. Hill, M.E., and Prof. Thos. French, Jr., of the Cincinnati University, the experts employed to test the comparative efficiency and economy of gas and electrical illumination of the depot under your charge, have submitted their reports; but as they cover over 50 pages of closely written matter, tables, etc., I have concluded to transmit and ask you only to carefully consider the summary.

These tests show, and I have no doubt your personal observation will confirm the scientific test, that the gas illumination was much more brilliant and satisfactory than that afforded by incandescent lights; and that at a saving of forty (40) per cent.; that supposing their charge will hereafter be more moderate and proportionate to showing made under

this test, we can still give you the same degree of illumination for nearly twenty eight (28) per cent. less cost.

And this by the use of ordinary burners and fixtures placed in your depot at the time of its construction; since which time such advances have been made in the construction of regenerative burners that with the more approved form of such you can obtain three times the volume of light per foot of gas that could formerly be obtained through the use of ordinary burners.

In connection with this report permit me to call your special attention to the fact that, while the promoters of electric light enterprises assert that the expense of steam to operate the dynamos is merely nominal, this test confirms the correctness of former experiments, and conclusively proves that under the most favorable conditions it is over one-third the total cost.

And, finally, in order that there may be no mistake in the practical interpretation of the results of this test, I will now, on behalf of the directory of this Company, agree to enter into a contract, for any desired number of years, to light your entire premises with gas, and guarantee that the degree of illumination shall in no case be less than that now afforded by electricity, and charge for such service but \$8,854 per annum, or *forty* (40) per cent. less than the incandescent lighting cost you last year.

Very respectfully, A. HICKENLOOPER, Prest.

OFFICE OF JNO. W. HILL, MECHANICAL ENGINEER, }
CINCINNATI, OHIO, Nov. 19, 1887. }

General A. Hickenlooper, President Cincinnati Gas Light and Coke Company: Dear Sir:—I have the honor to submit herewith a complete detailed report of the results obtained from the recent test of the Edison electric light plant at the Grand Central Station, this city.

As the compilation of the results appear quite voluminous, and may prove a little tiresome to follow out in all its details, I thought best to submit with it this summary.

This test covered an interval of sixteen days; the first eight being assigned to the Gas Company, the second eight, of which I had special charge, from 6 A.M., Oct. 11, to 6 A.M., Oct. 19, or 192 consecutive hours, being devoted to the other side, both being carefully carried on.

During the whole of that time careful observations were made of the lights in service; the average illuminating power of the lights; the power required to produce the light, and the cost of its production.

During this test the steam used for operating the elevator pumps and for heating the buildings was taken from a separate set of boilers, leaving one battery to be used exclusively in furnishing steam to the engines used in driving the dynamos, and the cost of which was found to be as follows:

Coke used (including fuel to start fires every two weeks)	
929 bush., at 7 cents.....	\$65.03
Water, to boilers, including waste to sprinkle ashes and clean boilers, 38,408.16 gallons, which, at 9 cents per 1,000 gallons.....	3.46
Wages, two firemen—one day and one night—at \$45 per month.....	23.68
Interest on investment and depreciation of boilers and fixtures.....	9.86
Total cost of steam supplied for eight days.....	\$102.03

In order to ascertain the cost per annum it is necessary to determine the ratio of lighting hours which these eight days bear to the entire year; both the bills rendered for electric lighting and the lighting time-table of the Gas Company show the dark hours of October to be one-tenth of the entire year; which taken as the basis of calculation make the actual cost of steam for one year supplied by the Depot Company, \$3,879.30.

The charge for electric light, exclusive of steam supply, is based upon the weight of zinc, in grammes, deposited during any interval of time, multiplied by the constant 17, gives the number of so-called "thousand-candle power" of light furnished for the interval, and for which they are, according to their contract, authorized to charge 45 cents per so-called "thousand-candle power" which charge is equivalent to \$7.65 per gramme of zinc transferred during eight days. The weight of zinc thus deposited—as weighed and reported by the Electric Light Company—was 21,829-1,000 grammes, which at \$7.65 per gramme, equals \$167 for eight days, or \$647.12 for month of October, or total cost per annum (exclusive of steam), \$6,471.26.

This discrepancy between the cost, as shown by this test, and the previous actual charge made to the Depot Company, cannot be reconciled by any possible change of conditions, or any known method of computation, and certainly shows that either during this test some method was successfully adopted with a view of materially reducing the apparent cost of electricity, or that the charge heretofore made for an equal degree

of illumination, has been disproportionate to the service rendered; for I am informed that for the month of October, 1886, the charge made was \$926.06, and for the year, \$10,784.82, making the total expense for one year's electrical illumination of the depot, according to this test, \$10,350.55.

And, according to actual amount charged for 1886 by the Electric Light Company, \$14,664.12.

The average illumination of all the lights in service at the depot buildings, train shed, omnibus court, along the tracks west of depot, and in the office and stables of the American Express Company, was equivalent to 185.15 lights of 16 actual candle power each, or 2962.4 candles.

Prof. French's test of the Cincinnati gas shows it to be 16.94-100-candle power.

An equal degree of illumination of gas—2962.4 candles—would require the use of $(16.94 \div 5 = 3.38$ candles per foot, $2962.4 \div 3.388 = 874.38 \times 24 \times 8$ days) 167,880.96, which, at \$1.15 per thousand, equal \$193.06.

Or, for October, \$748.11; or, for one year, total expense, \$7,481.10.

The total registered quantity of gas actually passing meters during the eight days' test was 214,700 cubic feet, of which 16,000 cubic feet (it is stated) was used by "thief lights" of old-style O'Neil lamps, leaving amount actually used for illuminating purposes, 196,700 feet, which, at \$1.15, equals \$228.50; for October, \$885.44; or for one year, \$8,854.40, thus showing:

First—That the same degree of illumination can be given with gas that was given by electricity, during the recent test, with a saving of \$2,869.45, or 27.72 per cent. per annum.

Second—That using gas without limitation, affording a higher degree of illumination, the expense would be \$5,809.72, or nearly 40 per cent. less than the actual cost of electrical illumination last year.

In the above estimate of cost of electricity—based on the transfer of zinc in the voltameters—it is assumed that the charge of the owners of the electric plant covers all the items of electricians' wages, interest, depreciation and profit on operation of plant, renewal of lamps, oil and waste for engines, and all other items of expense not otherwise specifically mentioned above.

Should this not be the case, but other items of expense of which I am unaware are borne by the Depot Company, then the cost and disparagement of the electric light becomes greater than I have shown it to be.

Apart from the cost of the light produced by the electric plant, there are other facts which have been pointed out in my general report, and to which I take the liberty of referring in this summary.

During the weighing of the zinc plates of the voltameters used by the Electric Light Company to measure the amount of light furnished to the Depot Company, the phenomenon (which I am informed is not unfrequent) was developed of the diminishing plate gaining instead of losing (as it should if the meter is working properly) in weight; showing an apparent reversal of current for meters Nos. 23, 24, 31, 32 and 39. The custom in cases of this kind being (as I am informed) to take the gain in weight of the plates—which should have lost in weight—as the measure of zinc transferred.

Although authorities on electrical science assert, with a given strength of current, the rate of transfer of zinc from one plate to another in a voltameter is constant for any given time, and knowing the time and current, the loss of zinc by the positive plate may be calculated from constants determined by experiment, it seems strange that the current should be reversed as it was in the meters noted above. And this fact of which we have ocular evidence, would indicate a state of affairs very dangerous to the pocket of the consumer of light. For if these meters will work backwards (as it were), why should they not work forwards at a rate greater than that assigned by theory, and cause a registration of more light than is actually furnished?

If I were a consumer of electric light I should require better evidence than that before me now to induce me to accept the record of these meters as a reliable statement of the light furnished.

Another fact to which I will again refer is the great range in candle power of the lights, with a slight change in the intensity or pressure of the electric current.

"Thus the (D) 32 nominal candle power lamp, with the filament placed at an angle of 45° to the plane of the photometer bar, with a resistance producing 99 volts, the current was 1.05 ampere, and the candle power 23.94; while with a resistance producing 99 volts the current was 1.268 ampere, and the candle power 42.89 or nearly twice as great as in the previous test."

The reduction of the resistance and current diminishes the load on the dynamos and engines, prolongs the life of the lamp, and materially diminishes the illuminating effect.

Should it appear that at any time during the day or night the voltage

(pressure) of the electric current is reduced below 99 volts, which I have reason (from our running record) to believe is the case, then the illumination produced will be greatly diminished from the standard, while the cost of the light to the consumer may be practically unchanged.

"From a comparison of currents required to maintain the test lamps it appears that the cost is about the same for a weak as for a strong light; while the illuminating effect (candle power) of the light steadily diminishes with age (use) the current (ampere) to maintain its incandescence remains substantially constant.

"As a matter of fact it may be shown that the current, and consequently the cost to the consumer, becomes greater with a lower candle power; thus:

<i>Thirty-two-candle Power Lamps.</i>	
Actual Candle Power.	Ampere.
62.44	1.25
30.16	1.31

Or, with a loss of illuminating effect of 50 per cent., the cost of the light is increased nearly 5 per cent., whence the relative cost of the weaker light is 217 per cent. of the stronger light.

<i>Sixteen-candle Power Lamps.</i>	
Actual Candle Power.	Ampere.
36.33	0.773
21.10	0.816

Or, with a loss of illuminating effect of 52 per cent., the cost of the light is increased over 5½ per cent., whence the relative cost of the weaker light is 182 per cent. of the stronger light. Or, while the electrical energy was $1.25 \times 99 = 123.75$ Watts for the 62.44-candle power light, it was $1.31 \times 99 = 129.60$ Watts for the 30.10-candle power light; and while the electrical energy was $0.773 \times 99 = 76.527$ Watts for the 36.33-candle power light, it was $0.816 \times 99 = 80.784$ Watts for the 21.10-candle power light."

The power of the driving engines and the dynamos is usually stated in Watts, being the product of horse power of engines into the constant 746, or the product of the electric current (ampere) into its pressure or intensity (volts). Hence the more Watts required to maintain a lamp, the greater the cost of the light.

With gas or kerosene a given consumption of illuminating substance furnishes a constant power of light, while a diminished brilliancy of light is always accompanied by a reduction in the consumption of illuminating material, and a corresponding reduction of cost.

With the Edison light, however, it seems that a reduced brilliancy of lamp is not accompanied by a reduction of expense, but under certain conditions of lamps and service the cost may be actually greater for a light of 16-candle power than for one of twice the brilliancy.

Changing the position of the filament (loop) of the lamp, under same conditions of current and pressure, produces a reduction of 50 per cent. in the illuminating power.

The most startling result of this test to me is the loss of over 60 per cent. in effect between the driving engines and the lamps, or of every foot pound of work, or Watt, developed by the engines, less than 40 per cent. is actually realized in the illuminating power of the lamps. In any other application of steam power to useful work the relation of the work done to the power expended in doing it must come within 80 or 90 per cent. of the latter to satisfy demands for economy.

The tests of lamps for brilliancy were made by Prof. French, of the Cincinnati University, and the test for current required to maintain the lamps was made by Mr. C. E. Jones, electrician of this city, whose reports were submitted with my general report.

All of which is respectfully submitted.

JOHN W. HILL.

ITEMS OF INTEREST FROM VARIOUS LOCALITIES.

THE ENGINEERS' CLUB, OF PHILADELPHIA, PA.—will celebrate its Bicennial Anniversary to-morrow evening. A reception is to be held at the Club House, No. 1122 Girard street, whereat the caterer will ring the dinner bell at 9 P.M. Those who intend to attend may safely count on a most enjoyable evening.

PUBLIC LIGHTING, ELIZABETH, N. J.—The following proposals have been submitted to the City Council: Schuyler Electric Light Company, arc lights (1,000-candle power, nominal), at from \$100 to \$120 per annum each, according to hours of duty. Incandescent lamps (16-candle power), at \$16.50 to \$17.50 each per year, the latter figure to be paid in case the lights are to remain in duty from sunset to sunrise. The New York and New Jersey Globe Gas Light Company offered to renew its present contract (500 lamps), and agreed to fit up the posts with the Company's new and improved lantern (the lights to be extinguished at 1 A.M.), for \$17 each per annum. If a 3 year contract was granted the price per

post would be reduced to \$16.50. If all-night lighting was determined on the lamps would be maintained on the basis of \$18.75 for a single year and \$18.25 for a 3-year contract. Every year that Elizabeth decides in favor of gasoline public lighting only serves to emphasize and advertise her poverty. Perhaps this unpleasant fact will finally come home to her rulers, ere their blindness will have put them beyond relief.

THE NORRISTOWN (PA.) GAS COMPANY has been making repairs to one of its gasholders, but seemingly to no avail. The task had been about completed—in fact, the vessel was being lowered into the tank when, through the breaking of a bolt, the holder tilted and a rather rapid and ruinous telescoping occurred. All the top rollers were wrenched off, three sheets were torn out, and the columns were badly strained. The masonry of the tank also suffered. Measures were at once taken to repair the damage, for the storage capacity of the holder is sadly needed by the Company just now.

THE BAXTER SPRINGS (KANSAS) COAL AND GAS COMPANY has been organized by Messrs. R. A. Love, C. D. Meserve, H. R. Crowell, and others. Capital, \$10,000. This place is on Spring River, and also on the Missouri River, Fort Scott and Gulf Railroad, at a point about 61 miles south of Fort Scott. Coal, lead and zinc are found in the vicinity.

PUBLIC LIGHTING, JACKSONVILLE, ILLS.—At a meeting of the City Council, held Dec. 1, a contract for the public lighting of the city was awarded to the Jacksonville Gas Light and Coke Company. The contract is to run for two years, and the Company agrees to perform the service for the sum of \$5,500 per annum. Strange to say, Ald. Meany complimented the officers of the Company for "their universal courtesy toward the [Lighting] Committee, and their endeavor to please the city in its requirements."

FOR THE WEEK ENDING DEC. 6 the Gas Inspector (Prof. Aiken) of Baltimore, Md., reports that the gas supply continued to show uniformity in illuminating power much above the standard of 16-candles. He also reports that during the week 120 samples of oil were procured from dealers and tested. Of these 14 samples flashed at the standard temperature of 120° F., while 106 flashed above the standard, the range being between 123° to 130°.

HOW THE INSPECTOR EXPLAINED IT.—The last weekly report presented to the San Francisco Board of Supervisors by Gas Inspector E. P. McCarthy, concerning the illuminating value of the gases supplied by the different gas companies of the city, showed that the gas companies were keeping well up to the requirements of the statutes. This state of affairs did not appear to suit the nice discrimination of Supervisor Norton, who was unable to reconcile the Inspector's findings with the complaints made by the consumers. Having formulated the query, the Supervisor received a reply from the Inspector, who said the reason gas seemed to many to be so poor was because consumers were employing a newly-invented gas regulator, which, although it apparently saved them about 25 per cent. in their gas bills, also gave them a 50 per cent. poorer light. Turning off the spigot, but removing the bung—as it were.

KILLED BY THE CURRENT.—On the evening of December 4, Elmer E. Wood, Manager of the Canandaigua (N. Y.) Electric Light Company, noticed that one of the street arc lamps was not burning properly, and sought to improve it by adjusting the carbons. The kid glove on his hand being wet transmitted the current to his body and he fell to the ground, dead. The only noticeable mark left on the corpse was a small hole, with blackened edges, in the right thumb.

CHEAPER GAS FOR BIG RAPIDS, MICH.—The proprietors of the Big Rapids Gas Company recently published the following notice: "On and after January 1, 1888, our discounts on gas bills will be changed as follows: Instead of a scale of discounts varying from 10 to 60 per cent. in proportion to the size of the bills over \$2, as now in use, there will be a uniform discount of 60 per cent. on the even dollars of the amount of all monthly bills over \$2, but no discounts will be allowed upon the first \$2, or upon the odd cents of any bill, large or small. No discount whatever will be allowed to parties who fail to pay their bills on presentation, or within 10 days thereafter. At these rates bills of any amount under \$3 will be net, and other bills will be as follows. For example, \$3 gross would be \$2.40 net; \$4 gross or \$2.80 net, and so on."

EXPLAINING A CHANGE.—In the course of a pleasant, chatty letter recently received by us from Mr. Geo. C. Hicks, President of the Chicago Retort and Firebrick Company, that gentleman thus explains the change which took place recently in the executive management of the Company:

"Our good friend Austin had to go to California, on account of his wife's health, this climate being too severe for her. Austin sold out his interest in the Company to Mr. C. A. Reed, an old friend of the writer. The change in the firm name was merely to reorganize, and have our office legalized in the Town of Lake, our former office having been in Chicago. We are enlarging our works and greatly increasing our facilities."

ANOTHER CHANGE.—Gerould's Improved Retort Cement is now being manufactured by C. L. Gerould & Co., with headquarters at Nos. 5 and 7 Skillman street, Brooklyn, N. Y., instead of at Manchester, N. H., as formerly.

CUPID'S CAPTURE AT AURORA, ILLS. Mr. Wm. B. Miller, who was recently chosen Secretary of the Aurora Gas Light Company, elected last Thanksgiving day as the proper date to pay a visit to Milwaukee, Wis. The records further show that he did not return home alone, because cards are now in circulation in Aurora which inform their recipients that Mr. and Mrs. W. B. Miller will be pleased to greet friends at their newly-chosen residence, No. 75 Holbrook street. The nuptial knot was tied on Thanksgiving day, at the home of the bride's parents, Milwaukee, Wis. May their journey through life be happy and prosperous.

PUBLIC LIGHTING, RED BANK, N. J.—The Board of Commissioners for Red Bank have awarded a contract for the public lighting to the Red Bank Illuminating Company. The Company is to receive \$1,300 per annum for 25 arc lights of the usual 2,000-candle power variety, and the contract is to last for three years. A moon-table is to be followed. The present cost of lighting the city by gas amounts to something less than \$1,100 per annum.

LIMA (O.) COMPLAINS.—A correspondent says that trouble is brewing at Lima between the citizens and the Lima Natural Gas Company, the latter being a first cousin of the Standard Oil Company. The people say that the Company does not furnish the quantity of gas which it promised to supply in consideration of the payment of certain specified monthly sums. The Company was granted the right of way through the streets without being required to keep the pressure at any specific figure, and as nearly all the residences have gas laid on, the suppliers now refuse to keep up the pressure. The only consolation or comfort vouchsafed the complainants is obtained in the advice to pay more money and put in larger burners. To show that ground for complaint exists, our correspondent says that on one or two occasions the schools had to be closed because the heat was insufficient to keep the temperature of the classrooms at a point where the scholars would not suffer.

PUBLIC LIGHTING, CLEVELAND, OHIO.—The bids recently opened by the City Clerk show the following: The Brush Electric Light and Power Company offered, on a basis of 3,700 hours of lighting, to supply 4,000-candle power arcs for 10½ cents per hour each, or 3¼ cents per hour for 2,000-candle power lights. On a basis of 2,300 hours per year the bid prices were 13½ and 4.8 cents per hour respectively. The bid was accompanied by the proviso that the lights should be in the vicinity of the present system of wires operated by the Company. The Peoples Gas Light Company and the Cleveland Gas Light and Coke Company offered similar sets of figures. They proposed to furnish gas for \$1 per thousand cubic feet; to light, extinguish and care for the lamps at \$2.12 per year each; to remove or reconnect old posts for \$3.50 each; to set new posts for \$4 each, and to lay new service pipes for 15 cents per foot. Messrs. Harrison and Many offered the only bid for gasoline lighting. They agreed, on an annual lighting schedule of 3,760 hours, to maintain the lamps at a charge of \$15.40 each, and propose to charge \$1.25 each for the removal of posts. The bidders named are those who are now furnishing light to the city under the contracts about to expire.

DOWN GOES THE RAHWAY (N. J.) SCHEDULE.—Gas consumers in Rahway are to receive a New Year gift at the hands of Secretary Houston, who has been empowered to inform them that from and after 1st prox. gas is to be supplied at the net rate of \$2 per thousand cubic feet. This concession is made from a gross charge of \$2.50 per thousand, although those who consumed certain maximum quantities have hitherto been granted a discount. In his letter to us on the subject Secretary Houston, in referring to the abandonment of the discount feature, says the latter was always the cause "of much grief" to him because of that consumer who inevitably and invariably made his appearance one day too late, on the occasion of which visit the delinquent never could be convinced that such a slight lapse was of any consequence, always winding up his argument with the plea that his discount be granted "just for

this time only." We hinted a fortnight ago that the Railway Company's management was of the improving sort, and the above proves the hint.

Mr. J. M. MURPHY has been appointed Western General Manager of the business of the Maryland Meter and Manufacturing Company. This appointment means that the entire Western business of the Company is under the direct supervision of a man thoroughly competent to care for it. Manager Murphy will also have complete control of the gas stove department, and he is quite likely to make a "success" of it.

Mr. H. F. DOUT is to act as Engineer for a Company whose proprietors propose to construct and operate gas and electric light plants at various eligible points in the Argentine Republic and elsewhere. South American capitalists control the undertaking. It is intended to make the first venture in La Plata (or Chuquisaca), a city of Bolivia, a plant with a per diem capacity of 100,000 cubic feet having been arranged for.

TO GO INTO THE ELECTRIC LIGHTING BUSINESS.—The Directors of the Laeclde (St. Louis, Mo.) Gas Light Company have determined to put in and operate an electric lighting plant of the most approved description. Both arc and incandescent lights will be furnished. It is somewhat amusing to note the kind of warfare now being waged against the Laeclde Company in order to compel the latter to merge its individuality in the St. Louis Gas Trust. In fact the diaphanous nature of the combat is pronounced. As almost everyone knows the St. Louis Gas, Fuel and Power (or water gas) Company is now part and parcel of the old St. Louis Company, and under the terms of the famous "tripartite agreement"—the parties thereto being the city and the old St. Louis and Laeclde Companies—it was determined that the latter Company should occupy the gas territory north of Washington avenue, while the former was to content itself with the southern portion of the city, the agreement to hold good until 1890. In the meanwhile the water gas speculators made a deal with the old St. Louis folks—the latter, by-the-way, getting much the worst of the bargain—and, when the Laeclde Company refused to be grabbed, the water gas charter was availed of as a sort of club wherewith to bring the Laeclde people to a comatose condition. In other words, the water gas tire of the Trust's wheel was turned in the direction of the "territory north of Washington avenue" and gas was sold there for \$1 per thousand, while in the "territory south of the avenue" \$1.50 was the ruling figure. And the other tripartite member—the city—looks calmly on, never saying a word. Some proof of the pudding is contained in the next "item."

ANNUAL ELECTION, ST. LOUIS (MO.) GAS COMPANY.—The following is from the St. Louis *Democrat*, of 6th inst.: "W. H. Thompson, President of the Gas Trust, controlled the election of Directors and officers of the St. Louis Gas Company yesterday. Of the 12,000 shares 11,554 were voted in the election for Directors, which took place in the morning, and Mr. Thompson voted 10,995 of these shares for the Trust. The four directors elected were David Rankin, jr., Peter Nicholson, Jno. R. Lionberger and Geo. T. Cram. Mr. Nicholson was the only one of the retiring directors who was re-elected, the three retiring ones being President Socrates Newman, Jno. Scullin, and Chas. Green. The new directors hold their offices for two years, and the five of the old board who remain in the directory—Messrs. W. H. Thompson, Chas. H. Turner, Thos. E. Tutt, Dwight Durkee and Geo. W. Fishback—will hold their offices one year longer. The new directors were selected at the last meeting of the Trust, and it was then decided also who the new officers should be. The new Board of Directors carried out the plans of the Trustees when the meeting for organization was held after the election. Mr. Thompson was elected President, Mr. Lionberger, President *pro tem.*, and Geo. M. Paschall was reappointed Secretary. The Board before adjournment adopted the following resolution: 'Resolved. That the thanks of this Board are due and hereby tendered to Mr. Socrates Newman, ex-President of this Company, who has during the past ten years so zealously labored for its interests. While we regret that the present condition of his health compels him to retire from active connection with this Company, we hope at the same time that in seeking a much deserved and long needed rest he may be restored to his former robust health, and be enabled in the near future to resume his usual business relations with the community. In his retirement from active connection with the Company he carries with him the best wishes of the members of this Board, who will gladly welcome his return to renewed health and active business life.' Ex-President Newman intends to go South shortly to spend the winter, and if he returns to St. Louis next year with improved health it is likely that he will resume active connection with the several enterprises in which he is interested."

HOW THE STRIKERS FARED.—Some of the helpers employed by the Norristown (Pa.) Gas Light Company thought they had Supt. Slingluff cornered immediately after the unfortunate accident which occurred to the gasholder that was being repaired, for in the midst of his added cares they coolly demanded an increase of 25 cents per day in their wages. They ought to have known Mr. Slingluff pretty well, since they had labored under him for some time—a kind employer we know him to be—but they must have been mistaken in their estimate. He told them of the injustice and inopportunness of their demand, but they persisted—and got their discharge. The Company was not in any way inconvenienced by the strike.

COUNCILMAN C. W. Eager, one of the Committee appointed by the Manchester (N. H.) authorities to inquire into the advisability of the operation of an electric lighting plant by the city, recently asked for an extension of the period originally agreed upon as a limit to their researches. The request was granted; but it would seem to be good policy were the Committee discharged from any further consideration of the matter.

THE Woodbridge (N. J.) *Sun* says that the Perth Amboy Gas Light Company is sending out an excellent quality of gas. Does that editor not place himself under suspicion as being a holder of Perth Amboy gas stock? Reflection, however, thrusts upon us the cold fact that editors, as a rule, are reasonably well off in this world's goods when they can proudly and truthfully boast of the possession of a well-made and staunch pair of suspenders.

AGREEING ON THE PRICE.—Some time ago we noted that the public lighting (hereafter to be electric) of Utica, N. Y., had been awarded to a new Company. As the contract with the Utica Electric and Gas Company—the gas portion of it, at least—expired on the 1st. inst., and as the new contractors would not be in readiness to go on with the work until Jan. 1, the City Council asked that the Gas Company continue its service to the public until the beginning of the new year. The Company agreed to supply the necessary gas at the rate of \$1.60 per thousand.

THE Carlisle (Pa.) Electric Light and Power Company has been organized. It is a very small affair.

THE Saco (Me.) authorities some months ago awarded the public lighting to an electric company, but the proprietors of the latter were not in readiness to go on with the work when the Gas Company's contract ended. The interval was bridged over by the Gas Company, but when the latter presented a bill for the accommodation (it was only \$296) the authorities thought the figure too steep, and the matter will occupy the attention of the Maine Supreme Court during the January term.

THE estimate of \$2,283 additional over the \$14,000 appropriated for the maintenance of the gas and electric lighting of the White House and grounds, Washington, D. C., is to provide for an electric light tower in the ellipse south of the White House grounds. This section is commonly spoken of as the "White Lot."

IN answer to many inquiries, it gives us great gratification to say that Mr. Jos. R. Thomas is rapidly recovering his normal physical condition.

LOWVILLE, N. Y., at the last charter election, decided to light its streets with kerosene oil lamps. The sum of \$500 was appropriated wherewith to carry on the work for a twelvemonth, but the powers that be now sorrowfully assert that the "appropriation was insufficient," instancing in proof that although the \$500 had been absorbed on the 1st. inst., only 5 bbls. of kerosene remained in store. The contents of the "bbls." will be carefully husbanded, but we nevertheless feel that, despite the greatest care and caution, some of Lowville's nights will be "dark and dreary" between now and Feb. 29, 1888.

MORRISTOWN, N. J., appropriated only \$3,500 wherewith to pay for the lighting during the fiscal year to end on May 1, 1888. The expense incurred in the six months ended Nov. 1 was something like 8 per cent. in excess of that which the appropriation would admit of. The 12 arc lights seem to be responsible in great part for the rapid diversion of the lighting fund. Morristown maintains 12 arcs, at \$120 each per annum; 59 gas lamps, at \$16 each; and 47 naphtha lamps, at 8½ cents each per night.

REORGANIZED.—At a recent meeting of the Knoxville (Tenn.) Electric Light Company the concern was completely reorganized. C. E. Dunstan, of Hartford, was elected President; J. P. McMullen, Vice-President, and D. J. Glazier, also of Hartford, Secretary and Treasurer. The

owners propose to enlarge the plant so as to furnish incandescent lights. Knoxville do not seem to take kindly to the electric light.

WHAT WAS ACCOMPLISHED BY THEM.—We were somewhat surprised on receiving official notification that the Messrs. Tarbell (father and son) had retired from the service of the Waltham Gas Light Company, and we are yet at a loss to understand why such step was taken. Popularity and efficiency have marked them in their relations to the Company, and we are sorry that the change was made. We think Mr. Tarbell, Sr., became Superintendent of the Waltham plant about 10 years ago. At that time the annual output was not in excess of 6 millions cubic feet, the consumers numbering 400, and the leakage account was abnormally high—certainly not less than 30 per cent. of the total make—while \$3 per thousand was the ruling selling price. At present the sendout is not less than 24 millions cubic feet per annum; the ledgers show the names of over 700 consumers; the unaccounted-for gas figures out at less than 5 per cent.; and the selling rate averages out at \$1.92 per thousand. Ten years ago the works were in bad condition, while now they are in a complete and perfect condition. In fact, practically, they have been rebuilt. Two gasholders (aggregate capacity 165,000 cu. ft.) were erected. Of these one is arranged to take a second lift, when the necessities of business call for increased holder room, thus guaranteeing an additional 100,000 cu. ft. storage capacity at a comparatively trifling expense. Five miles of distributing mains were buried; the introduction of cooking and heating stoves was pushed with vigor; and the value of high-power gas burners was intelligently demonstrated. These things certainly prove that the Messrs. Tarbell kept abreast of the times. Within a year a 4-dynamo electric plant was installed, which was equal to the duty of supplying 100 arc and 400 incandescent lamps. Nor was the electric department of the business neglected, for the electric annex at the present time is sending out the equivalent of 70 arcs and 125 incandescents. The main offices of the Company, also, were located in handsome and commodious quarters on the Welch Block, right in the business center of the city. These facts and figures go to prove that the Tarbells can give a good account of their stewardship, and may rest content in the knowledge that the Waltham Company's interests did not suffer when their hand was on the helm.

The annual illumination at St. Louis, Mo., this fall was on a greater scale than ever, and was a thorough success, as usual. The total cost was \$20,070.46. The number of gas jets burned is returned at 57,239, of which 29,863 were inclosed in colored globes. The item of breakage is quite an important one, this year's experience having cost the managers a loss of 7,784 globes. The annual illumination is now one of St. Louis's fixed events.

GAS COAL FOR THE PHILADELPHIA WORKS.—Director Wagner has awarded the following allotments to be made for supplying gas coal to the Philadelphia municipal gas works during the ensuing year. The bids were opened on December 6th:

Contractor.	Tons Awarded.	Price per Ton.
Jas. Boyce.....	35,000	\$3.79
Despard Coal Company.....	10,000	3.79
Newburgh Orrel Coal and Coke Co.	30,000	3.79
Manor Coal Company.....	10,000	3.83
J. & W. Wood (gas coal).....	40,000	3.79
“ “ (Hopetoun cannel).	6,000	9.10
Penn Coal Company.....	84,500	3.84
Westmoreland Coal Company.....	84,500	3.84
Total.....	300,000	

It will be noted that the figures show an increase over the last awards of 10 cents per ton. Manufacturers might take notice that Philadelphia intends to put up 1,000 new gas posts and lamps, and 800 of the gas-line variety during 1888.

A CERTIFICATE incorporating the Buffalo (N. Y.) Illuminating Company has been filed. The Trustees (D. E. Bailey, C. E. Clark, T. H. Meyer, Jr., H. R. Howland and E. G. S. Miller) set forth the purposes of the Company to be "the generation, manufacture and distribution of illuminants in the city of Buffalo." Buffalo, we thought, was pretty well provided for in this respect at the present time.

VIRGINIA CITY (Nev.) is putting in an electric plant; and the Presque Isle (Me.) Electric Light Company has been incorporated.

THE Ogdensburgh (N. Y.) Gas Light Company expects to supply electric light before the holidays. The initial capacity will be that from a 50-light dynamo.

IT is not likely that the City Council of Cleveland, Ohio, will grant a franchise to those interested in the present movement for an opposition company. The argument made before the Lighting Committee of the Council, by Mr. J. H. Morley, President of the Cleveland Gas Light and Coke Company, was well adapted for the end in view. It was a decidedly telling argument.

THE Brookline (Mass.) Gas Company has sent out a circular to the residents stating that it is prepared to supply them with incandescent electric lights, provided a sufficient number of subscribers can be found to guarantee a fair profit on the capital requisite to carry on the work. It is proposed to charge 2½ cents per hour of use for each 16-candle power incandescent light.

JNO. S. HOLLINGSHEAD, a clerk in the employ of the Washington (D. C.) Gas Light Company, is an absconder. His cash is over \$1,000 short.

PEOPLE who are connected with the Austin (Texas) telephone exchange have reason to know and be fearful of the freaks occasionally traceable to contact between the exchange wires and those of the local Mather Electric Light Company. Perhaps the exchange itself has suffered the most, for the office switchboard and other paraphernalia of the establishment have been injured, in fact burned out, once or twice during the last month. The Mather Company operates respectively a Westinghouse incandescence and a Brush arc specimen.

THE Buffalo (N. Y.) public lighting awards appear to have been made on the following basis: Arc lights (2,000-candle power) of the Brush, United States and Thomson-Houston types at the uniform rate of 47½ cents each per night. The three gas companies agree to supply gas, from and after Jan. 1, 1888, at the rate of \$1.35 to the city, and \$1.40 (net) to the public.

THE Medina (N. Y.) Common Council has authorized the Thomson-Houston Company to maintain forty 2,000-candle power public arcs in that city for one year. The lights are to remain in duty 22 nights each month. Price, \$62.50 each per annum.

THE Coshocton (O.) Gas Light and Coke Company proposes to make its capital equal \$31,000—an increase of \$6,000.

THE Edison Company now talks of attempting to sell plants to the gas companies, instead of establishing independent corporations, as heretofore.

CHEAPER GAS FOR HOLYOKE, MASS.—Although the gas department of the Holyoke Water Power Company's business nominally figures as of secondary importance in its transactions, we nevertheless incline to the belief that, practically, Brother Snow's annual contribution to the Company's account in bank makes an imposing addition to the funds available for distribution in the shape of dividends among the fortunate holders of stock in that well-managed corporation. This year the Directors determined to grant the gas consumers a share in their prosperity—a plan adopted some years ago—for we note that Brother Snow is in the field announcing a reduction in rates, to take effect on and after Feb. 1, 1888. From that date ordinary consumers are to pay \$1.75 net per thousand, while wholesale users will obtain their supply at \$1.50. Very acceptable tidings for the holiday season, surely.

The Conservation of Energy.

Mr. S. Dixon, at a meeting of the Manchester (England) Association of Engineers, presented a paper on the above-named topic. Having referred to a paper previously read by him before another meeting of the Society, and briefly summarizing the principles underlying the conservation of energy, Mr. Dixon proceeded to trace the amount of power available from the combustion of coal under given conditions. Beginning with boiler making, he said that an exhaustive series of experiments made by Mr. Michael Longridge, in 1884, demonstrated that the average efficiency of ordinary Lancashire boilers amounted to about 54 per cent. Comparing this with the effect obtained from the marine boiler, as shown by the paper recently communicated to the Institution of Mechanical Engineers, it was found to be a very inferior result, the efficiency of marine boilers having been there shown to be 80 per cent., the consumption of coal per horse power per hour being 1½ pounds.

The difficulty of ascertaining accurately what the engine was doing was one which pressed hardly upon anyone investigating the subject, as the data commonly related to the engine and boilers combined. In the report of Mr. Longridge, just referred to, however, an experiment made

on a pair of compound engines indicating 900-h. p. showed that out of the total heat there was utilized about 12 per cent. The author then referred to the law of Carnot, and said that denoting the absolute temperature of the source of heat by T , and the absolute temperature of the condenser by t , the absolute efficiency is given by the well-known formula:

$$\frac{T-t}{T}$$

Taking the case of the Corliss engines above referred to, the temperature of the steam entering was 309° F., and that of the ejection water, 106° F., from which, by applying the above formula, it is deduced that the efficiency of the engines is 26 per cent. The conversion of the whole of the heat into mechanical energy is only possible with a perfect engine, where the temperature of the condenser is absolute zero, but as this is impracticable all that can be done is to approach this point. Reverting to the case of the Corliss engines named, and comparing their efficiency with that of a perfect engine working between the same temperatures, the result is an efficiency of 41 per cent.

These engines were using 2 pounds of coal per h. p. per hour, but the averages over a number of engines, as given by one of the boiler associations, are as follows:

Compound engines, condensing, 3.66 pounds; single cylinder, condensing, 5.88 pounds; single cylinder, non-condensing, 7.95. Now, comparing these results with those of triple expansion marine engines, as recorded in the paper spoken of, they will be found to be very inferior. The author next referred to gas engines, and took the Otto as an example, observing that, up to the present, the economical results of this engine had not been surpassed. Taking an average of 20 cu. ft. of ordinary gas per hour as used by this engine, and calculating that each foot produces 620 units of heat, the total heat supplied to the engine would be 12,400, and as the units theoretically required for 1 h. p. are 2,564, it shows an efficiency of 20.6 per cent. Applying Carnot's principle, and calculating the efficiency of this engine as compared with a perfect engine working between the temperatures of combustion in the cylinder, viz., 3,000° F. and 1,250° F.—the assumed temperature of the discharged gases—the maximum efficiency would be 58 per cent., and it will be seen that an Otto works with an efficiency of 38 per cent. of that of the perfect engine.

An actual experiment established that 29 per cent. of the total heat was effective, the remaining portion being represented by 69 per cent. absorbed by the water jacket, and 2 per cent. from direct radiation. The amount of coal used per h. p. per hour by the Otto when Dowson gas is used is 1.3 pound; but it has been found that when the Dowson gas is produced from coke 1.4 pounds are needed per h. p. Turning now to the useful energy finally left after distribution, Mr. Dixon commented on the paucity of information at the command of investigators, saying that in the records of the insurance companies there must be a mass of valuable information as to the relative efficiency of various modes of communicating power. A gentleman of considerable experience, to whom the author had appealed, had, however, given him some details which showed that in mills using 800 to 1,000 h. p. it is found that the total energy absorbed by the friction of engines, shafting, etc., was from 20 to 30 per cent. of the whole power, sometimes reaching 35 per cent. Of the three main plans for driving, strap driving absorbs 5 per cent., and rope driving 10 per cent., more energy than spur gearing. Referring now to electricity, Mr. Dixon said that Sir Wm. Thomson had asserted that power could be transmitted three hundred miles with a loss of but 20 per cent.

An actual experiment made in Paris during last year established the fact that in transmitting 200 horse power 35 miles 50 per cent. was found to be lost. Even when we thus got the power into the factory or workshop, it would be found that an enormous waste of power was taking place in the operations of all machines, and that this required constant attention. The time lost in the use of machine tools was chiefly that required for setting, which was more than that occupied in cutting. The use of long chimneys was then referred to as a clumsy means of obtaining draught, and forced hot blast was advocated. Mr. Dixon then referred to some diagrams, stating graphically the results obtainable in a perfect engine, and those actually obtained, and showed that with an engine working with steam at a pressure of 200 pounds, and the heat in it finally reduced to a temperature of, say, 50° F., the realizable efficiency is only 40 per cent. Against this, Corliss engines are utilizing 14 per cent., and triple-expansion engines 15.9 per cent. The diagrams, which were constructed to scale starting at absolute zero of temperature, showed that the possible efficiency of gas engines was about 83 per cent. The use of a dynamometer in a convenient form was then recommended, in order to test the amount of power actually transmitted through a shaft or machine. The failure of the coal supplies of the country was then referred to, and it was pointed out that a great responsibility rested upon engineers to see that no power was wasted.



A. M. CALLENDER & CO.,
PROPRIETORS.

Editor—JOS. R. THOMAS, C.E.
Asst. Editor—T. J. CUNNINGHAM
Manager—C. E. SANDERSON.

PUBLISHED ON THE 2ND AND 16TH OF EACH MONTH
At No. 42 Pine Street, New York.

This is a recognized official organ of—
LIGHT, HEAT, STEAM, WATER-SUPPLY,
VENTILATION, SANITARY IMPROVEMENT
AND GENERAL SCIENCE.

TERMS

SUBSCRIPTION—Three Dollars per annum, in advance.

AGENTS

NEW YORK—AMERICAN NEWS CO. 39 and 41 Chambers St.
BOSTON—S. M. PETTENGILL & Co., 6 State Street.
PHILADELPHIA—PRATT & Co., Corner 9th and Arch Streets.
England—C. W. HASTINGS, 22 Buckingham St., London, W. C.
Germany—B. WESTERMANN & Co., of New York

FRIDAY, DECEMBER 16, 1887.

The Market for Gas Securities.

The market for city gas shares is again in the doldrums, but no substantial reason can be given for the existence of such a state of affairs. The output of the Consolidated Company is taxing its resources to the utmost, and amply proves the wisdom of its managers in their expenditures on plant account last spring and summer. The other city companies are also obtaining their share of business. The Brooklyn situation remains unchanged, and some demand for shares has stiffened the tone of the market. We note a sale at auction of 10 shares of Williamsburgh, at 112½. Washington (D. C.) gas is offered at 192½. The Baltimore deal, as far as consolidation is concerned, is off for the present, the Chesapeake Company having declined to scale its stock. The rate war, however, is not likely to be renewed just now. Chicago Trust stock is weak and strong by turns. Boston advices, per the remarks of the State Street News Bureau, say that the old Company offers to make 3 year contracts with those who consume \$2,000 worth of gas annually on the basis of \$1 per M.

The Bay State Company will hardly be ready to supply gas before April 1st, and if the old Company does not come to an understanding with its competitor before that date, the latter, we understand, will institute a 75 cent rate.

Noting all things connected with the gas supply of Boston, we fail to see how the Messrs. Greenough can be beaten in the contest for supremacy.

Montreal gas is considerably lower, 75 shares having changed hands last week at 191½.

Western shares, as a rule, hold their values, and the same may be said in a general way of approved southern securities.

Gas Stocks.

Quotations by Geo. W. Close, Broker and Dealer in Gas Stocks.

16 WALL ST., NEW YORK CITY.

DECEMBER 16.

All communications will receive particular attention.
The following quotations are based on the par value of \$100 per share.

	Capital.	Par.	Bid	Asked
Consolidated.....	\$35,430,000	100	70½	—
Central.....	440,000	50	30	—
“ Scrip.....	220,000	—	47	57
Equitable.....	2,000,000	100	110	—
“ Bonds.....	1,000,000	—	113	115
Harlem, Bonds.....	170,000	—	—	—
Metropolitan, Bonds....	658,000	—	110	113
Mutual.....	3,500,000	100	90	93
“ Bonds.....	1,500,000	1000	101	—
Municipal, Bonds.....	750,000	—	—	—
Northern.....	125,000	50	30	—
“ Scrip.....	108,000	—	—	—
Yonkers.....	—	50	—	80
Richmond Co., S. I.	300,000	50	50	—
“ Bonds.....	12,000	—	—	—
Gas Co's of Brooklyn.				
Brooklyn.....	2,000,000	25	100	103
Citizens.....	1,200,000	20	50	—
“ S. F. Bonds... ..	320,000	1000	—	103
Fulton Municipal.....	3,000,000	100	128	130
“ Bonds.....	300,000	—	—	103
Peoples.....	1,000,000	10	60	53
“ Bonds (5's).....	368,000	—	97	—
“ “ (6's).....	94,000	—	100	—
Metropolitan.....	1,000,000	100	72	76
Nassau.....	1,000,000	25	90	95
“ C'tfs.....	700,000	1000	95	100
Williamsburgh.....	1,000,000	50	110	115
“ Bonds... ..	1,000,000	—	111	—
Out of Town Gas Companies.				
Boston (Mass.) Gas Co	2,500,000	500	220	—
Buffalo Mutual, N. Y....	750,000	100	90	95
“ Bonds... ..	200,000	1000	95	100
Citizens, Newark.....	1,000,000	50	110	147
“ “ Bonds.....	45,000	—	—	—
Chicago Gas Trust.....	25,000,000	100	38	38½
Cincinnati G. & C. Co..	6,000,000	100	178	180
Consolidated, Balt.....	6,000,000	100	56½	56¼
“ Bonds.....	3,600,000	—	107	107½
Chesapeake, Balt.....	1,000,000	100	86	—
“	1,000,000	—	100	102
Consumers Toronto....	1,000,000	50	192	—
Central, S. F., Cal.....	—	—	—	84
Capital, Sacramento, Cal.	—	—	57½	60
Hartford, Conn.....	750,000	25	—	138
Jersey City.....	750,000	20	—	138
Laclede, St. Louis, Mo.	2,000,000	100	118	120
Louisville, Ky.....	2,570,000	50	108	114
Little Falls, N. Y.....	50,000	100	95	100
“ Bonds.....	25,000	—	100	103

Advertisers Index.

GAS ENGINEERS.	Page
Jos. R. Thomas, New York City	498
Wm. Henry White, New York City	498
Wm. Mooney, New York City.....	498
William Gardner, Pittsburgh, Pa.....	498
GAS WORKS APPARATUS AND CONSTRUCTION.	
James R. Floyd, New York City	411
T. F. Rowland, Greenpoint, L. I.....	411
Deily & Fowler, Phila., Pa	411
Kerr Murray Mfg. Co., Fort Wayne, Ind....	410
Stacey Mfg. Co., Cincinnati, Ohio	411
Bartlett, Hayward & Co., Baltimore, Md	401
Morris, Tasker & Co., Limited, Phila., Pa	410
Davis & Farnum Mfg. Co., Waltham Mass	378
R. D. Wood & Co., Phila., Pa	410
Bouton Foundry Co., Chicago, Ills	410
Smith & Sayre Manufacturing Co., New York City.....	410
PROCESSES.	
National Gas Light and Fuel Co., Chicago, Ills.	402
American Gas Improvement Co., Pittsburgh, Pa	400

GAS AND WATER PIPES.

Gloucester Iron Works, Phila., Pa.....	408
Mellert Foundry and Machine Co., Reading, Pa. (John Fox, Selling Agent, N. Y.)	408
Cincinnati and Newport Iron and Pipe Co., Newport, Ky....	408
Ohio Pipe Co., Columbus, Ohio.....	408
Pancoast & Rogers, New York City.....	408
M. J. Drummond, New York City.....	408
Wells Rustless Iron Co., New York City.....	408
R. D. Wood & Co., Phila., Pa.....	410

RETORTS AND FIRE BRICK.

J. H. Gautier & Co., Jersey City, N. J.....	406
B. Kreischer & Sons, New York City.....	406
Adam Weber, New York City	403
Laclede Fire Brick Works, St. Louis, Mo.....	406
Brooklyn Retort and Fire Brick Works, Brooklyn, N. Y.	406
Borgner & O'Brien, Phila., Pa.....	406
James Gardner, Jr., Pittsburgh, Pa.....	406
Henry Maurer & Son, New York city.....	406
Chicago Retort and Fire Brick Co., Chicago, Ills.....	399
Baltimore Retort and Fire Brick Co., Baltimore.....	406
Oakhill Gas Retort and Fire Brick Co., St. Louis, Mo.....	406
Eveus & Howard, St. Louis, Mo.....	407
Cincinnati Gas Retort and Fire Brick Works, Cincinnati, O.	407
Emil Lenz, New York City.....	407

GAS ENGINES.

Schleicher, Schumm & Co., Phila., Pa	416
Clerk Gas Engine Co., Phila., Pa.	403

SCRUBBERS AND CONDENSERS.

G. Shepard Page, New York City.....	409
R. D. Wood & Co., Phila., Pa.....	410

REGENERATIVE FURNACES.

Bartlett, Hayward & Co., Baltimore, Md.....	401
Fred. Bredel, New York City.....	407
Chicago Retort and Firebrick Co., Chicago, Ills.....	399
H. C. Hann, Baltimore, Md.....	399

GAS GOVERNORS.

T. C. Hopper, Phila., Pa	401
Connelly & Co., New York City.....	403

CEMENTS.

C. L. Gerould & Co., Brooklyn, N. Y.....	406
--	-----

GAS ENRICHERS.

Standard Oil Co., Cleveland, Ohio.....	412
--	-----

GAS METERS.

Harris, Griffin & Co., Phila., Pa.....	414
American Meter Co., New York and Philadelphia	415
The Goodwin Gas Stove and Meter Co., Philadelphia, Pa....	415
Helme & McIlbenny, Phila., Pa	415
D. McDonald & Co., Albany, N. Y.....	415
Nathaniel Tufts, Boston, Mass.....	414
Maryland Meter and Manufacturing Co., Baltimore, Md.	414

EXHAUSTERS.

P. H. & F. M. Roots, Connersville, Ind.....	402
Smith & Sayre Manufacturing Co., New York City.....	411
Wilbraham Bros., Philadelphia, Pa.....	403
Connelly & Co., New York City.....	403

GAS COALS.

Penn Gas Coal Co., Phila., Pa.....	413
Perkins & Co., New York City	412
Newburgh Orrel Coal Co., Baltimore Md	413
Despard Coal Co., Baltimore, Md.	413
Chesapeake and Ohio R.R. Coal Agency, N. Y. City.....	413
Westmoreland Coal Company, Phila., Pa	413
Monongahela & Peters Creek Gas Coal Co., Pittsburgh, Pa.	413

CANNEL COALS.

Perkins & Co., New York City.....	412
J. & W. Wood, New York City.....	412

VALVES.

Ludlow Valve Manufacturing Co., Troy, N. Y.	404
John McLean, New York City	404
Chapman Valve Manufacturing Co., Boston, Mass	404
R. D. Wood & Co., Phila., Pa.....	410
The Combination Gas Machine Co., Detroit, Mich.....	407

PURIFYING MATERIAL.

S. H. Douglas, Ann Arbor, Mich.....	407
Connelly & Co., New York City.....	403

ENGINES AND BOILERS.

Jarvis Engineering Co., Boston, Mass.....	403
---	-----

GAS LAMPS.

The Siemens-Lungren Co., Philadelphia, Pa.	409
G. Shepard Page, New York City.....	372
Albo-Carbon Light Co., Newark, N. J.....	400
Standard Gas Lamp Co., Phila., Pa.....	407

PURIFIER SCREENS.

John Cahot, New York City.....	399
Geo. A. Mills, Baltimore, Md.....	403

GAS STOVES.

American Meter Co., New York and Philadelphia... 105
 The Goodwin Gas Stove and Meter Co., Phila. Pa. ... 381
 The Combination Gas Machine Co., Detroit, Mich. ... 407
 Dismore Manufacturing Co., Boston, Mass. ... 407

STREET LAMPS.

J. G. Miner, Morrisania, New York City... 399
 Bartlett Street Lamp Mfg Co., New York City... 399

BURNERS.

C. A. Gehringer, Phila., Pa. ... 412

STEAM BLOWER FOR BURNING BREESE.

H. E. Parson, New York City... 404

GAS FIXTURES.

Mitchell, Vance & Co., New York City... 404

GASHOLDER TANKS.

W. C. Whyte, New York City... 410

COKE CRUSHER.

C. M. Keller, Columbus, Ind. ... 413

ELECTRICAL APPARATUS.

Waterhouse Electric & Manufg Co., Hartford, Conn. ... 400

BOOKS, ETC.

English Journal of Gas Lighting... 399
 Goodwin's Directory of Gas Light Companies... 412
 King's Treatise... 401
 Scientific Books... 414
 Management of Small Gas Works... 408
 Newbigging's Gas Manager's Handbook... 414
 Gas vs. Electricity... 407
 Practical Electric Lighting... 103
 Electric Light Primer... 43

CHARLES L. LEVÉY,
 Electrical Engineer and Contractor,
 DEALER IN SUPPLIES.
 61 Broadway, New York.

I beg to call the attention of parties desiring to take advantage of my vast experience in the different systems of both the **Arc and Incandescent Lighting**, to offer my services as Consulting Engineer.

The great advantage of Electric Lights over Gas is no longer a matter of doubt. It has proven itself the power of the future, and the time is now at hand when gas will only be used for heating purposes.

To persons desiring electricity in any form, for either power or light, I would say, my long experience enables me to act for my clients with a certain degree of assurance that their wishes will be fully realized. And those who wish to consult me on any point can do so, as I make no charge, unless I am called on to examine plants already installed. I am the Agent for all the principal Electric Light companies, and can give such prices as will satisfy all. I have no interest in advancing any particular company, and am therefore prepared to advise, without prejudice to either, as to which system of the many companies (now before the public) would be most economical to adopt.

As each company naturally insists that its system of lighting is superior to that of its rival, and the knowledge on the subject possessed by people in general, is not sufficient to enable them to judge between all these claimants for favor, I think intending purchasers will hardly fail to see the advantage of being able, before adopting any particular system, to secure my assistance which, from my knowledge of the different companies' plants, am prepared to advise.

I also supply all articles required for light and power, with **Engines, Boilers, Wire Carbons, Lamps, Instruments, &c., &c.**

Correspondence solicited on every point.

CHARLES L. LEVÉY,
 Electrical Engineer and Contractor,
 61 BROADWAY, NEW YORK.

Engagement Desired AS SUPERINTENDENT,

By a competent man of large experience in the manufacture and distribution of gas (coal and water) and construction of gas plants. A1 references furnished. Address 681-11 "E." care this Journal.

FOR SALE.

"Journal of Gas Lighting."

A complete set from its commencement—1819 to 1881, inclusive. Thirty-eight volumes, in cloth, as issued, \$200. Address 684-1 "S.," Box 1741, N. Y. City.

Hann's Hot Air Generator FOR GAS RETORTS.

(Patented Nov. 28, 1882.)

Simple! Effective!

Suitable for any style of Gas Bench, from one to six retorts. No excavating. Built within the Bench.

Now in successful operation at the following Gas Works, viz.:

- 16 Benches 6's, Equitable Gas Light Company, N. Y. City.
- 20 " 6's, Equitable Gas Lt. and Fuel Co., Chicago, Ill.
- 36 " 6's, Chesapeake Gas Lt. Co., Baltimore, Md.
- 8 " 5's, Charleston Gas Lt. Co., Charleston, S. C.
- 1 " 3's, Palatka, Fla.
- 1 " 5's, Fitchburg, Mass.
- 2 " 5's, North Adams, Mass.
- 1 " 6's, Saco, Me.
- 1 " 5's, Georgetown, D. C.
- 2 " 3's, Cambridge, Md.

Address, for further particulars, **WALDO BROS., 88 Water St., Boston, Mass. Balto. Retort & Fire Brick Co., Balto., Md. And H. C. HANN, Patentee and Contractor for all kinds of Gas House Masonry, 607 S. Paca St., Balto., Md.**

ENGLISH

"Journal of Gas Lighting."

Issued weekly. New volume commences Jan. 1, 1887. Price, \$7 per annum. Subscriptions taken by

CHARLES NETTLETON, Agent for U. S.,
 No. 115 BROADWAY, N. Y. CITY.

Bartlett Street Lamp Mfg. Co.

MANUFACTURERS OF

Globe Lamps,

FOR

Streets, Parks, Public Buildings, Railroad Stations, etc.

LAMP POSTS

A Specialty.

Office and Salesroom,
 40 & 42 COLLEGE PLACE, - - N. Y. CITY.

Gas Companies and others intending to erect Lamps and Posts will do well to communicate with us.



THE GLOBE STREET LAMP.



MINER'S PATENT STREET LAMPS.

Are adapted for use of Streets, Parks, Depots, Ferries, & Private Grounds.

WITH POSTS OR BRACKETS.

Jacob G. Miner,
 No. 823 Eagle Ave., New York, N. Y.

CHURCH'S REVERSIBLE TRAY

For Purifiers and Scrubbers.

OVAL OR RECTANGULAR SLATS.

FOR LIME OR IRON SPONGE,
 MALLEABLE IRON CROSS BARS.

Strongest! Most Durable!
Most Easily Repaired!

MANUFACTURED BY

JOHN CABOT,

306 to 310 Eleventh Ave., N. Y. City.

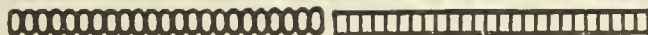

Patented July 9, 1878, and Feb. 5, 1884.

Used by the principal Companies in every State of the Union. Price List on application.

CHICAGO RETORT AND FIRE BRICK COMPANY,

GEO. C. HICKS,
 President.

45th, Clark and La Salle Streets, Chicago, Ill.

CHAS. A. REED,
 Sec. & Treas.

Manufacturers of Standard Clay Retorts, Gas Works Tiles and Settings, Fire Bricks, Ground Fire Clay, Fire Mortar, Blocks for Locomotives, Cupolas, Boilers, Ovens, etc.

The Hicks Regenerative Furnace.

FOR LARGE OR SMALL GAS WORKS. NO ROASTING PITHOLE FOR THE STOKERS. NO EXCAVATION BELOW THE ORDINARY ASHPAN.

This Bench is applicable everywhere as a practical adaptation of the Regenerative and Recuperative System, giving, at a moderate cost, a very high efficiency, with great saving of labor and coke. Even with an isolated bench we guarantee a production of 42,000 ft. per bench of 6's, 14" x 26" x 5', on 30 per cent. of coke, hot or cold, with probable production of 48,000 ft. if desired. We also construct the highly successful *Two-Story Regenerative Benches* on the plans of Mr. A. Arndt, Engineer of the Chicago Gas Light and Coke Co. Also, the *Sloping Retort System* of Henry Pratt, Engineer of the Peoples Gas Light and Coke Company, of Chicago.

Fire Clay Materials for Water Gas Cupolas, etc. Special Attention to Making Tiles and Blocks to Order.

Boston Agents, FISKE, COLEMAN & CO.

Illuminating Gas from Natural Gas.

THE AMERICAN GAS IMPROVEMENT CO., Limited, 95 Fifth Avenue, Pittsburgh, Pa.

Erect Apparatus for the treatment of Natural Gas for an Illuminant under the

McKAY-CRITCHLOW SYSTEM.

Satisfaction in Economy and Quality Guaranteed.

Apparatus adapted to the manufacture of Water Gas, without any change whatever, should it be desirable to do so on account of Natural Gas playing out. Apparatus erected or Licenses sold at the following Works.

Pittsburgh Gas Works, J. H. McElroy, Engr.
Allegheny Gas Works, Robt. Young, Engr.
East End Gas Works, W. H. Denniston, Engr.
West Pittsburgh Gas Works, E. C. Critchlow, Supt.
Beaver Falls Gas Works, H. F. Dillon, Supt.
Titusville Gas Works, E. T. Roberts, Treas.
Salamanca, N. Y.
Jamestown, N. Y.
Meadville, Pa., Wm. Reynolds, Pre-t.

Warren, Pa., S. S. Franklin, Supt.
Franklin, Pa., C. W. Gilfillan, Prest.
Oil City, Pa.
Erie Gas Co., Erie, Pa., W. H. Hill, Engr.
Greensburg, Pa., Jas. C. Clarke, Prest.
Sewickley, Pa., J. W. Forbes, Supt.
Bellaire, Ohio, John Ferguson, Supt.
New Castle, Pa., D. T. Flick, Supt.
Corry, Pa.

Sharon, Pa., S. Perkins, Prest.
Fort Scott, Kansas, L. K. Scofield, Owner.
Fostoria, Ohio, Jos. Gwynn, Supt.
Emporia, Kansas.
Tiffin, Ohio.
Wellsville, Ohio.
Brownsville, Pa.

We claim to furnish an Arc or Incandescent System that can be purchased

Without Fear of Injunctions for Infringement of Patents.

The Waterhouse System saves Coal; saves 25 per cent. in Cost of Steam Plant. Other systems Expensive at any Price. It has an Instantaneous Automatic Regulator, and we will guarantee that the Lights produced will Successfully Compete with any Arc Light in the World for Size, Color, and Steadiness. We are very busy. Book your Orders at once.

THE WATERHOUSE ELECTRIC AND MFG. COMPANY,
Factory, Colt's West Armory. **Hartford, Conn.**

THE ALBO-CARBON LIGHT.

THIS SYSTEM HAS SHOWN ITSELF IN THOUSANDS OF CASES—IN HALLS, CHURCHES, PICTURE GALLERIES, CONCERT HALLS, RESTAURANTS, BANKS, CLUBS, STORES, OFFICES, and PRIVATE RESIDENCES—TO BE THE

Best Adapted and Most Successful Method of Gas Lighting Ever Offered.

The SOFTNESS AND PURITY OF THE LIGHT make it most desirable for Office and Household Uses. Its BRILLIANCY and POWER render it unrivaled for lighting Halls, Churches, etc. Its ECONOMY secures for it general favor wherever used.

NOTICE.—Suits are pending in the United States Circuit Courts in Illinois and Pennsylvania against various parties for infringement of our Letters Patent No. 247,925, dated October 4, 1881, and No. 333,862, dated January 5, 1886. The first of these suits has come up for hearing, and an injunction has been granted therein. The second of said suits has not yet been reached for hearing. All persons are cautioned against manufacturing, selling, or using any apparatus or material which infringes our patents. We intend to prosecute all parties infringing patents owned by us.

ALBO-CARBON LIGHT CO. (Sole Manufacturers for the United States) Main Office, Newark, N. J.

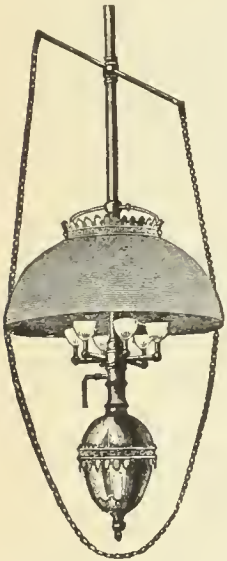
**To All Whom It May Concern!**

The SIEMENS-LUNGREN COMPANY hereby warns the public against the use of various infringing Regenerative Gas Lamps which are offered for sale. This Company has heretofore delayed bringing suit to enjoin the manufacture or importation of such infringing lamps, solely because of the practical worthlessness of the infringing devices; and although, in each instance, they infringe some one or more of the various patents owned or controlled by this Company, they have fallen into disuse sooner than any suit could be brought to a hearing. As, however, the introduction of these infringing lamps has tended to discredit the practicability of our Company's system of regenerative gas lighting, we have instructed our Attorneys, Messrs. Geo. Harding, C. S. Whitman, and Silas W. Pettit, to give notice that legal proceedings will in future be taken against all such infringers.

THE SIEMENS-LUNGREN CO., 21st St. & Washington Av., Phila., Pa.

BARTLETT, HAYWARD & CO.

Baltimore, Md.

Munich Regenerative Furnace, System Drs. Schilling & Bunte.

Greatest durability; minimum of attention; complete distillation in 3½ hours; 10 to 13 pounds of coke to hundred weight of coal; no clinker; no carbonic oxide in regenerative flues.

TWO AND THREE-LIFT TELESCOPIC GASHOLDERS,

With Wrought Iron Tanks, constructed above ground, of any magnitude.

Condensers, Scrubbers, Purifiers, Bench Castings, Roofs, Boilers, Etc.

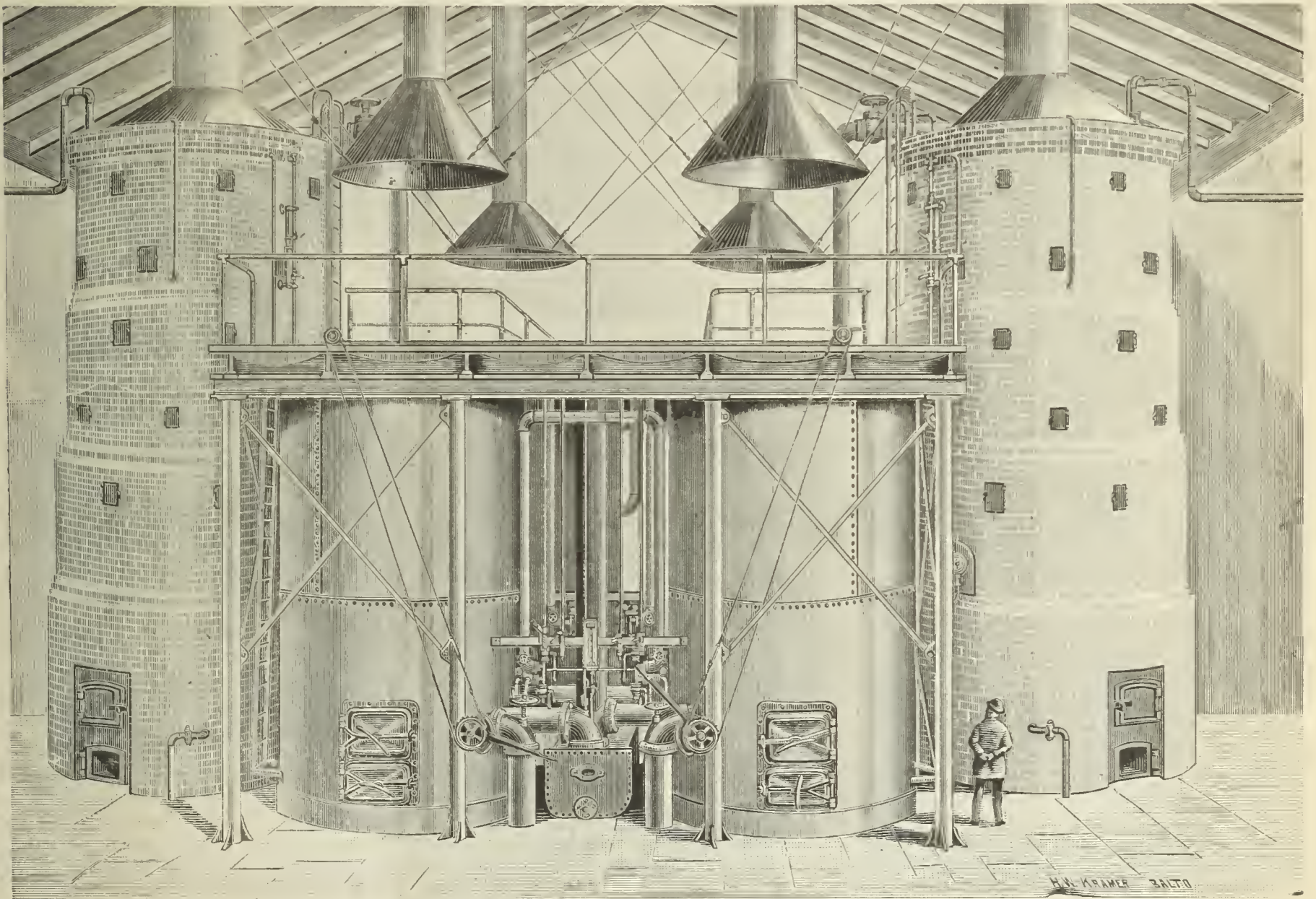

The Wilkinson Water Gas Process.

Introducing the Munich Regenerative Furnace for Coal Gas, we find on the part of many Gas Companies the desire to combine to a greater or less extent an efficient system of making high candle power Water Gas; and with a view of enabling this to be done WITHOUT EXCESSIVE CHARGES FOR PATENT RIGHTS, ETC., we have acquired, by purchase, the exclusive right to construct all the Water Gas Apparatus under the valuable "Wilkinson" Patents.

The results obtained by this Process are far better than those obtained by any other apparatus, especially where an illuminating gas of high candle power or a fuel gas of intense temperature is required.

The Process is uninterrupted, making gas of uniform quality and quantity. Its greatest advantages are maximum production with minimum material and labor, combined with great durability of apparatus.

The Process is in successful operation at the works of the N. Y. Mutual Gas Company, New York; Consolidated Gas Company, Baltimore, Md.; the Hudson County Gas Light Company, of Hoboken, N. J.; and at Rye, N. Y.

We shall be glad to give further detailed information upon application.

Sole Agents for the Celebrated Hazelton Boiler.

BARTLETT, HAYWARD & CO.

EXHAUSTERS.

EXHAUSTERS.

PROCESSES.

NATIONAL GAS LIGHT AND FUEL COMPANY,

No. 218 La Salle Street, Chicago.

THE SPRINGER SYSTEM

OF

Fuel and Illuminating Water Gas Works.

REFERENCES.

People's Gas Light and Coke Co.....	Chicago, Ill.	Mankato Gas Light Co.....	Mankato, Minn.
Elgin National Watch Co.....	Elgin, Ill.	Minneapolis Gas Light and Coke Co..	Minneapolis, Minn.
C. R. I. & P. R. R. Shops.....	Chicago, Ill.	Lima Gas Light Co.....	Lima, Ohio.
Decatur Gas Light and Coke Co.....	Decatur, Ill.	Bellevue Water and Fuel Gas Light Co.....	{ Bellevue, Campbell County, Ky.
Niles Gas Light Co.....	Niles, Mich.	Bucyrus Gas Light and Fuel Co.....	Bucyrus, Ohio.
Newton Illuminating Co.....	Newton, Kansas.	Morris Gas Co.....	Morris, Ill.
Wellington Light and Heat Co.....	Wellington, Kansas.	Los Angeles Gas Co.....	Los Angeles, Cal.
Chippewa Falls Gas Light Co.....	Chippewa Falls, Wis.	Sau Diego Gas Fuel and Electric Lt. Co.....	San Diego, Cal.
Elkhart Gas Light and Coke Co.....	Elkhart, Ind.	Jackson National Gas Co.....	Jackson, Mich.
Madison City Gas Light Co.....	Madison, Wis.	Sioux Falls Gas Co.....	Sioux Falls, Dak.
South Bend Gas Light Co.....	South Bend, Ind.	Dakota Gas and Fuel Co.....	Grand Forks, Dak.
Sheboygan National Gas Co.....	Sheboygan, Wis.	St. Johns Mutual Gas Co.....	St. Johns, Mich.
Salina Gas Light Co.....	Salina, Kansas.	Stillwater Gas Light Co.....	Stillwater, Minn.
The Rathbun Co.....	Deseronto, Prov. Ont.	St. Paul Gas Light Co.....	St. Paul, Minn.
Jefferson City Gas Light Co.....	Jefferson City, Mo.		

GUARANTEED ESTIMATES of Cost of Gas Furnished on Application.

ROOTS' NEW GAS EXHAUSTER.

St. Louis, Mo.,
March 21, 1887. }

Messrs. P. H. & F. M. Roots, Connersville, Ind.:
Dear Sirs—In 1872 one of your No. 5 Exhausters was placed in these works, and worked satisfactorily. In March, 1885, it was replaced by one of your No. 6 Exhausters. The latter has been in almost constant use the past two years, has worked up to all my expectations, and is to-day in apparently as good condition as when first set up. It has not cost one cent for repairs in all that time. I have also

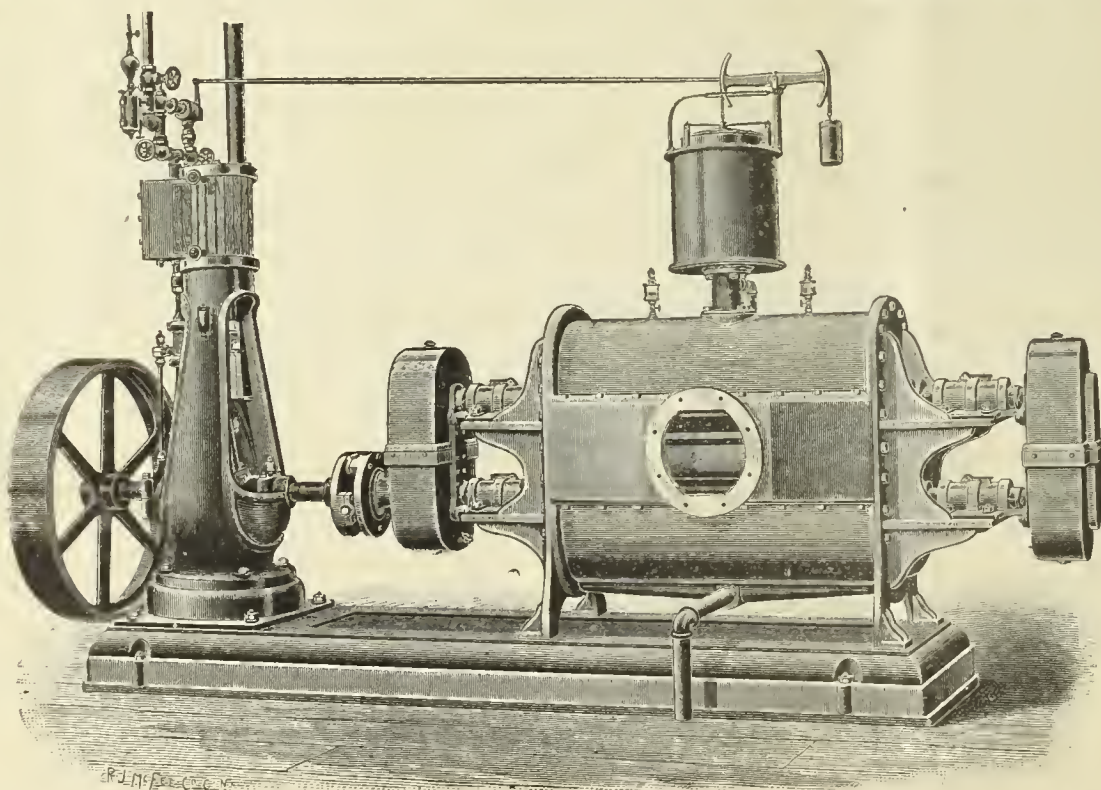

had one of your No. 1 Exhausters, with Engine on same bed-plate, fitted with your valves and Huntoon Governor, placed in a small works under my control, and in its operation it seems as near perfection as I ever expect an Exhauster to become. Without in the least disparaging Exhausters of other makes, I may say that your Exhanster may be safely recommended as unsurpassed by any other, to those requiring such machines.

Yours respectfully,
FREDERIC EGNER,
Eng. and Supt.

CONSTRUCTED ON ENTIRELY NEW PRINCIPLES.

THE ONLY EXHAUSTER MADE IN WHICH

The Internal Operating Parts Consist of Only Two Pieces, Each Cast Entire in One Piece.

Send for Descriptive Catalogue and Price List.

P. H. & F. M. ROOTS, Patentees and Manufacturers, **CONNERSVILLE, IND.**

S. S. TOWNSEND, Gen. Agt., 22 Cortlandt St., N. Y. COOKE & CO., Selling Agts., 22 Cortlandt St., N. Y.

CONNELLY & CO., LTD.,

SOLE MANUFACTURERS OF THEIR PATENTED SPECIALTIES.

"IRON SPONGE." Saves money, saves labor, and is the most efficient purifying agent ever offered as a substitute for lime. Now used in every State in the Union, and purifying daily over twenty-five million cubic feet. Should be used in every gas works. Its own saving will pay for it many times over.

AUTOMATIC GOVERNOR. Has been on the market but two years, and in that time has been introduced more generally than any invention ever designed for use in gas works. Over one hundred of them now in use. Sensitive; reliable; perfectly automatic; reduces leakage; satisfies consumers, and gives great relief to the Manager. No gas works is complete without one of these machines.

STEAM JET EXHAUSTER. Designed particularly for small works. Combines Exhaust Tube, Steam Governor, Gas Compensator, and Bye-Pass Valves in the most compact form possible; occupies but little space; uses very little steam; operated by ordinary workmen; saves formation of carbon in retorts; increases yield 10 to 15 per cent. Specially adapted for mixing air with oil gas. No works too small to use them profitably.

Prices given on all our specialties delivered at any point in the United States. Correspondence solicited.

CONNELLY & CO., LTD., No. 177 Broadway, New York City.

WILBRAHAM GAS EXHAUSTER

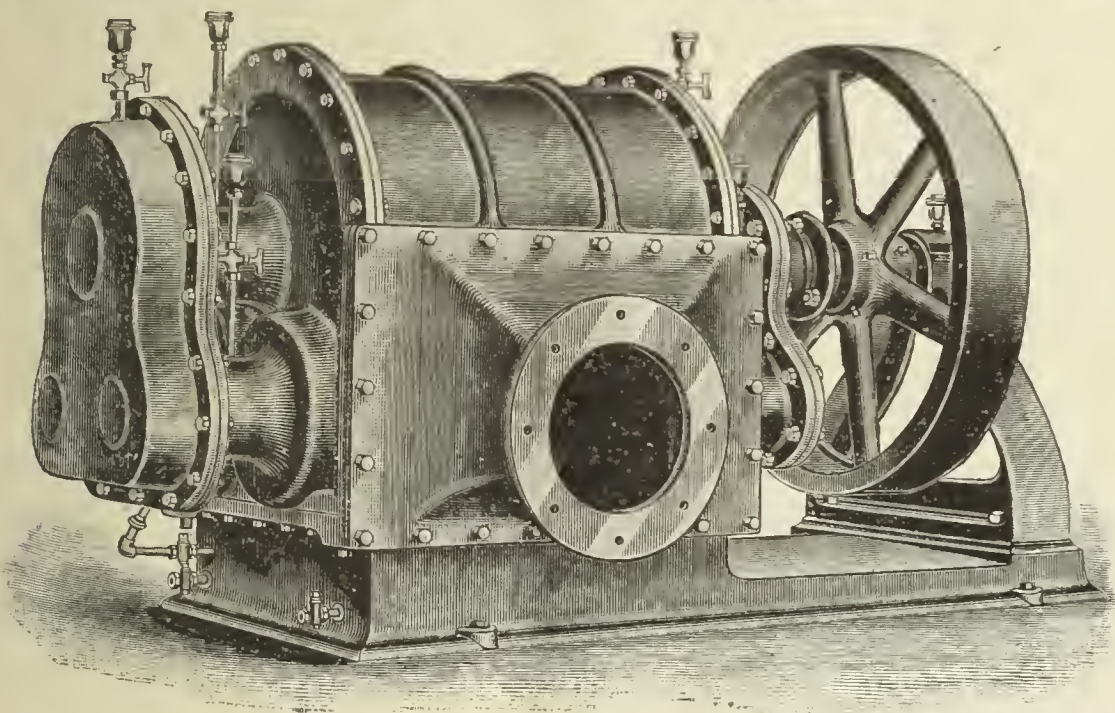

WILBRAHAM BROS.,
PHILADELPHIA, PA.

JARVIS ENGINEERING CO.,

61 Oliver St., Boston, Mass.

CONTRACTORS FOR ERECTING

COMPLETE STEAM OUTFITS FOR ELECTRIC LIGHTING STATIONS.

Steel Boilers set with Jarvis Pat. Boiler Setting

To burn **COKE SCREENINGS** for Fuel.

ARMINGTON & SIMS CO. ENGINES,

Belting direct to Dynamos, without using Shafting.

SEND FOR CIRCULARS.

REFERENCES.—Charlestown Gas & Electric Light Co., Charlestown, Mass.; Schenectady Gas & Electric Light Co., Schenectady N. Y.; Brookline Gas Co., Brookline, Mass.

Practical Electric Lighting,

By A. BROMLEY HOLMES, A.M.I.C.E.

With 87 Illustrations. Third Edition. Price, \$1.00.

Electric Light Primer.

By CHARLES L. LEVEY.

A simple and comprehensive Digest of all the most important facts connected with the running of the Dynamo and Electric Lights, with Precautions for Safety, etc.

Price, 50 cents.

A. M. CALLENDER & CO., 42 Pine St., N. Y.

THE CLERK GAS ENGINE CO.,

Main Office, 1012, 1014, 1016, 1018 Filbert St., Philadelphia, Pa.

WM. W. GOODWIN, Prest.

E. STEIN, Sec.

S. LEWIS JONES, Asst. Sec.

A. J. DOTY, Supt.

The utility and convenience of the Gas Engine being no longer an open question, it only remains now for intending purchasers to select the BEST. We claim for the CLERK GAS ENGINE that it is equal to any other manufactured as regards steadiness in running, simplicity, and ease of keeping in repair, and that it gives the greatest amount of power for the least money (both in first cost and expense of running) of any engine made. In support of this claim we refer to the test of the Gas Engines made under the direction of the American Institute of New York, in December, 1885, and heretofore published in these columns. These engines are especially adapted for continuous running under heavy loads, and we can refer to Engines which have run 22 hours a day for months at a time

Made in Sizes of 5, 10, 15, 20, and 25 Horse Power. All Engines Guaranteed for One Year.

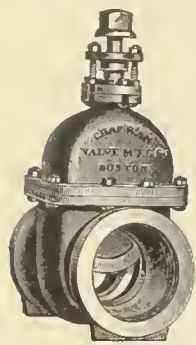

CHAPMAN VALVE MANUFACTURING CO., LUDLOW VALVE MFG. CO.

MANUFACTURERS OF

Valves and Gates for Gas, Ammonia, Water, Etc.

Also, Gate Fire Hydrants With and Without Independent Nozzle Valve. All Work Guaranteed.

WORKS & GEN'L OFFICE:
Indian Orchard, Mass.

TREASURER'S OFFICE:
72 Kilby & 112 Milk Sts, Boston, Mass.

How to Reduce Leakage to Its Minimum.

USE

HOPPER'S AUTOMATIC DIFFERENTIAL GAS GOVERNOR.

Needs No Attention. Simple, Reliable, Perfectly Automatic.

"Nearly Thirty in Use."

BYE-PASSES, DRY CENTER VALVES, PRESSURE REGISTERS. Also, GOVERNORS FOR STREET MAINS, *NOT DIFFERENTIAL*, and for EXHAUSTERS, GAS ENGINES, etc.

Our new Bye-Pass is threefold in its action—passes gas through, or bye-passes, or shuts off entirely. Correspondence solicited; information given. Send for circulars and testimonials.

T. C. HOPPER & CO., - - No. 2227 Wood Street, Philadelphia, Pa.

MILLS' REVERSIBLE LIME TRAY,

AND

WOODWORK

Of Every Description

NEEDED BY GAS WORKS.

SEND FOR CIRCULAR AND PRICE LIST TO

GEORGE A. MILLS,

Canton Av. & President St., Baltimore, Md.

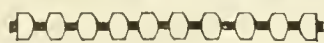
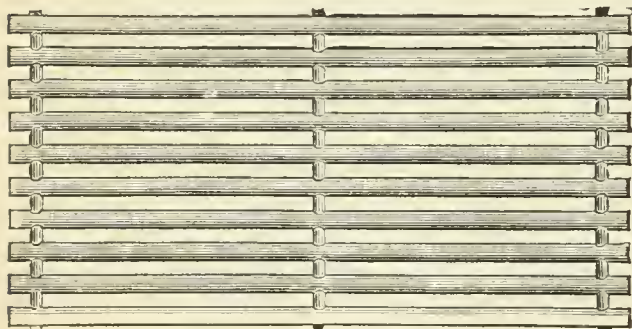

Parson's Steam Blower,

FOR IMPROVING BAD DRAUGHT IN BOILERS, AND FOR BURNING BREEZE OR OTHER WASTE MATERIAL.

PARSON'S TAR BURNER

FOR UTILIZING COAL TAR AS FUEL.

PARSON'S AIR JET TUBE CLEANER,

FOR CLEANING BOILER TUBES.

These devices are all first-class. They will be sent to any responsible party for trial. No sale unless satisfactory. Manufactured by the WATERTOWN STEAM BLOWER COMPANY.

H. E. PARSON, Supt., 33 & 35 Liberty St., N. Y.

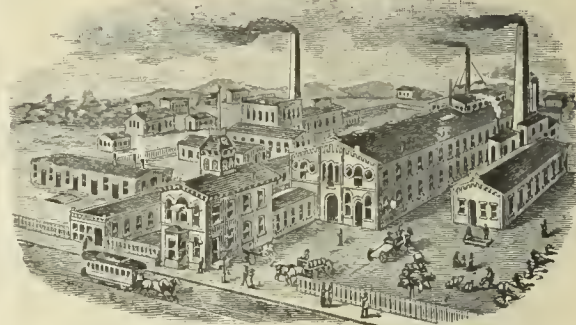

OFFICE AND WORKS,

938 to 954 River Street and 67 to 83 Vail Av
TROY, N. Y.

Hydraulic Main Dip Regulators, also
Check Valves, Foot Valves, Yard-
wash and Fire Hydrants
Send for Circulars.

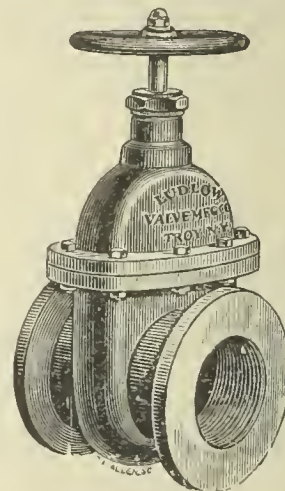

Valves.—Double and Single Gate, 1/2 in. to
48 in., outside and inside Screws. Indica-
tor, etc., for Gas, Water, Steam, and Oil.
Send for Circulars.

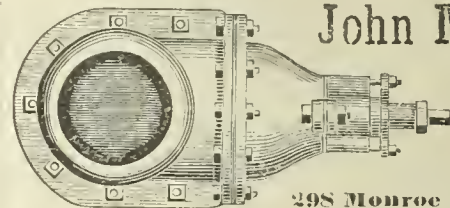

John McLean

Man'facturer of

**GAS
VALVES.**

298 Monroe Street, N. Y.

MITCHELL VANCE & CO.,

MANUFACTURERS OF

Chandeliers

and every description of

GAS FIXTURES.

Also manufacturers of Fine Gilt Bronzes and Marble Clocks, warranted best time-keepers. Mantel Ornaments, etc.

Salesrooms, 836 Broadway, N. Y.

Special Designs furnished for Gas Fixtures for Churches, Public Halls, Lodges, etc.

KING'S TREATISE

ON THE SCIENCE AND PRACTICE OF THE

MANUFACTURE AND DISTRIBUTION OF COAL GAS.

A standard text-book for the Engineers and Managers of Gas Works, and for all who are concerned or take an interest in the manufacture and distribution of Coal Gas, and in the utilization of the Secondary Products resulting therefrom; treating also of the Gas Engine, and of Gas Cooking and Heating Appliances.

In 3 Vols. Price per Vol., \$10. Sold either by Volume or in Sets.

A. M. CALLENDER & CO.,

No. 42 Pine Street, N. Y. City.

GAS STOVES.

GAS STOVES.

GAS STOVES.

THE AMERICAN METER CO.,

MANUFACTURERS OF

GAS COOKING AND HEATING STOVES.

Gas
Heating
Stoves
in
all
Sizes
for
Parlors,
Chambers
and
Offices.

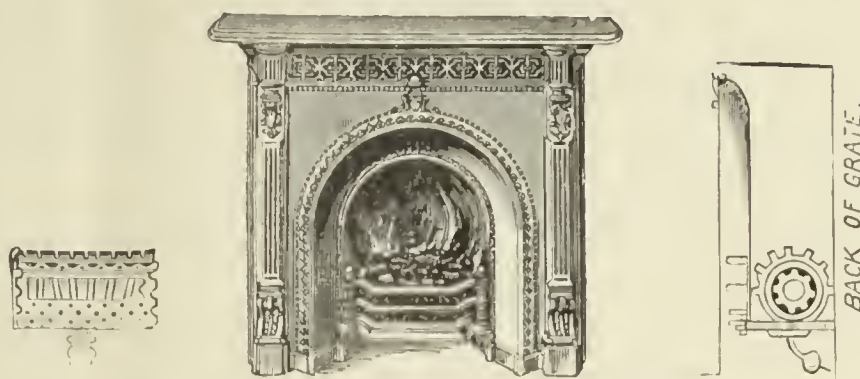

Verity's and Wilson's Patent Gas Fires For Open Fireplaces.

Gas
Cooking
Stoves
and
Ranges
in
all
Sizes
for
Family
and
Hotel
Use.



Catalogues and Price Lists on Application.

Catalogues and Price Lists on Application.

MANUFACTORIES,

508 to 514 West Twenty-second St., N. Y. Arch and Twenty-second St., Phila
Nos. 244 & 246 North Wells Street, Chicago, Ill.

AGENCIES,

No. 177 Elm Street, Cincinnati, Ohio. No. 222 Sutter Street, San Francisco Cal
No. 810 North Second Street, St. Louis, Mo.

GAS STOVE SHOW ROOMS, No. 223 Sixth Avenue, New York City.

RETORTS AND FIRE BRICK.

J. H. GAUTIER & CO.,

CORNER OF

GREENE AND ESSEX STREETS,
JERSEY CITY, N. J.

MANUFACTURERS OF

**Clay Gas Retorts,
Gas House Tiles,
Fire Bricks, Etc. Etc.**Ground Clay, Fire Brick and
Fire Sand in Barrels,J. H. GAUTIER.
C. E. GREGORY.T. B. GAUTIER.
C. E. GAUTIER.**BROOKLYN****Clay Retort & Fire Brick Works,**

(EDWARD D. WHITE & CO.)

Manufacturers of Clay Retorts, Fire Brick,
Gas House and other Tile.VAN DYKE, ELIZABETH, RICHARDS & PARTITION STS.
Office, 88 Van Dyke St., Brooklyn, N. Y.

RETORTS AND FIRE BRICK.

LACLEDE FIRE BRICK MFG. CO.,

MANUFACTURERS OF

Fire Brick, Gas Retorts,

AND

ST. LOUIS STANDARD SEWER PIPE.Blast Furnace and Cupola Linings, every description of Fire
Clay Material, Fire Clay Flue Linings, Chimney Tops
Dry Milled and Crude Fire Clays, etc.

OFFICE AND DEPOT

901, 903, and 905 Pine Street,
ST. LOUIS, MO.

ESTABLISHED IN 1845.

B. KREISCHER & SONS,

OFFICE FOOT OF HOUSTON ST., E.R., N. Y.

Gas Retorts,**TILES, FIRE BRICK.**

AND EVERYTHING IN THE FIRE CLAY LINE.

RETORTS AND FIRE BRICK.

MANHATTAN

FIRE BRICK & ENAMELLED CLAY

RETORT WORKS.**ADAM WEBER.****CLAY GAS RETORTS**

AND RETORT SETTINGS

FIRE BRICKS, TILES, ETC.,

Office and Works, 15th Street and Avenue C., N. Y.



Works,

LOCKPORT STATION, PA.

—ESTABLISHED 1864.—

JAMES GARDNER, JR.,

Successor to WILLIAM GARDNER & SON.

Fire Clay Goods for Gas Works.

CHAS. H. SPRAGUE & SON, No. 70 KILBY STREET, BOSTON, MASS., Agents for the New England States.

Office, Rooms 19 & 20, Lewis Block,
PITTSBURGH, PA, P. O. Box 373.

OFFICE, 418 to 422 East 23d St., New York.

ESTABLISHED 1856.

WORKS, PERTH AMBOY, NEW JERSEY.

HENRY MAURER & SON,**Excelsior Fire Brick & Clay Retort Works**

CLAY GAS RETORTS, BENCH SETTINGS, FIRE BRICK, TILES, ETC.

CHICAGO**Retort and Fire Brick Co.,**

OFFICE AND FACTORY,

Clark, Forty-Fifth, and La Salle Streets,
CHICAGO, ILL.

GEORGE C. HICKS, PRES. CHAS. A. REED, SEC. & TREAS.

STANDARD

Clay Retorts and Settings.**BLOCKS & TILES**

of every Shape and Size to Order.

Standard Fire Bricks.**GEROULD'S IMPROVED RETORT CEMENT.**A Cement for patching retorts, putting on mouthpieces, and
making up all bench-work joints. This Cement is mixed ready
for use. Economic and thorough in its work. Fully warranted
to stick. For recommendations and price list address**C. L. GEROULD & CO.,**
5 & 7 Skillman St., Brooklyn, N. Y.

Western Agent, H. T. GERGULD, Mendota, Ill.

OAKHILL**GAS RETORT & FIRE BRICK**

Works.

Proprietors,

PARKER-RUSSELL MINING & MFG. CO.

City Office, 711 Pine Street,

ST. LOUIS, MO.

Our immense establishment is now employed almost entirely in
the manufacture of**MATERIALS FOR GAS COMPANIES.**We have studied and perfected three important points. Our re-
torts are made to stand changes of temperature, the strongest
heats of the furnace, and the abrasion of feeding and emptying.
Our customers are in almost every State of the Union, to all of
whom we refer

THOS. SMITH, Prest. AUGUST LAMBLA, Vice-Prest. & Sup

BALTIMORE**RETORT & FIRE BRICK CO.**

MANUFACTORY AT

LOCUST POINT, BALTIMORE, MD.

Connection with the City by Telephone.

Clay Retorts, Blocks & Tiles,**FIRE BRICK, FIRE CLAY,****AND FIRE CEMENT.**Red and Buff Ornamental Tiles and Chim-
ney Tops. Drain and Sewer Pipe (from
2 to 30 inches). Baker Oven Tiles
12x12x2 and 10x10x2.**WALDO BROS., 88 WATER ST., BOSTON, MASS**

Sole Agents the New England States.

EVENS & HOWARD,
916 Market St., St. Louis. Mo.
Works, Howard Station, Mo. Pacific R.R.

Fire Brick, Gas Retorts

AND
RETORT SETTINGS.

Sewer Pipe, 3 to 24 in. diameter.
Glass Pot Clay, Ground Fire Clay, in barrels and in bulk. All kinds of Fire Clay Goods.

Cincinnati Gas Retort & Fire Brick Works.
—ESTABLISHED 1872.—

CHAS. TAYLOR,

MANUFACTURER OF

Gas Retorts, Fire Brick, and Tile.

Blast Furnace Linings, Cupola Blocks, Boiler Tiles, Grate Settings, and Stove Linings. Fire Cement, Fire Clay, Fire Sand, and all other Fire Clay Goods.

Branch Works, New Cumberland, W. Va.

GENERAL OFFICE AND WORKS,

Burns St., Cincinnati, Ohio.

EMIL LENZ,

2 & 4 Stone St., N. Y. City.

CLAY GAS RETORTS

(ENAMELED.)

Fire Brick, Blocks & Tiles.

FIRE CEMENT, RETORT ENAMEL, RETORT CEMENT, ETC., ETC.

Regenerative and Half-Regenerative Benches.

PORTLAND CEMENT.

Correspondence Respectfully Solicited.

GAS vs. ELECTRIC LIGHT.

We would invite attention to the able and exhaustive argument of General A. Hickenlooper, President of the Cincinnati Gas Light and Coke Company, contained in a handsome pamphlet of 96 pages, entitled

"EDISON'S INCANDESCENT ELECTRIC LIGHTS FOR STREET ILLUMINATION. REPORT OF AN ARGUMENT DELIVERED BY A. HICKENLOOPER BEFORE THE COMMITTEE ON LIGHT, MUNICIPAL COUNCIL, CITY OF CINCINNATI, JULY 22, 1886."

This is a subject of special interest to all Gas Light Companies.

Prices.

25 copies.....	\$7.50	100 copies.....	\$22.50
50 copies.....	12.50	250 copies.....	50.00

A sample copy will be sent by mail on receipt of 50 cts.

A. M. CALLENDER, & CO., 42 PINE ST., N. Y. CITY.

PATENTS.

FRANKLIN H. HOUGH,

Solicitor of American & Foreign Patents

925 F. ST., WASHINGTON, D. C.

(NEAR U. S. PATENT OFFICE.)

Personal attention given to the preparation and prosecution of applications for Letters Patent. All business before the U. S. Patent Office attended to for moderate fees. **No Agency in the United States possesses superior facilities for obtaining Patents,** or for ascertaining the patentability of inventions. Copies of patents furnished for 25 cents each. Correspondence solicited.



STEPHEN A. MORSE, President.
GODFREY REBMANN, Vice-Pres.

M. B. DYOTT,
Superintendent.

EDWIN F. MORSE, Secretary.
CARLTON M. WILLIAMS, Treas.

STANDARD GAS LAMP CO.,

Office, 411 Cherry St. Factory, 1101, 1103 & 1105 Frankford Av.

Philadelphia, Pa.

It is to the interest of Gas Companies and Cities to use Dyott's Patent Champion Lamps, which give double the light with the same consumption of gas, and will save 50 per cent. over others in cost of keeping in repair. Gas Companies and others intending to erect Lamps of any description will do well to communicate with us. Special Drawings furnished and Estimates given on application upon Architects', Engineers' or our Draughtsmen's Plans.

Our Patent System of Instantaneously Lighting Gas (without electricity) for R. R. Depots is unequalled. Our High Candle Power Burner is superior to the Electric Light or any other High Candle Burner. We manufacture every description of Ornamental Lamps.

KLOENNE & BREDEL

IMPROVED REGENERATIVE FURNACES.

Self-Sealing Mouthpieces & Bridge-Pipes, Retort Houses,

WASHER-SCRUBBERS

Gasholders, and Complete Gas Works.

Refers, by permission, to Mr. Eugene Vanderpool, of Newark, N. J.; Mr. E. G. Cowdery, of Milwaukee, Wis.; and Mr. Theo. Forstall, of Chicago, Ill. For further information apply to

FRED. BREDEL, 332 East 17th St., N. Y. City.

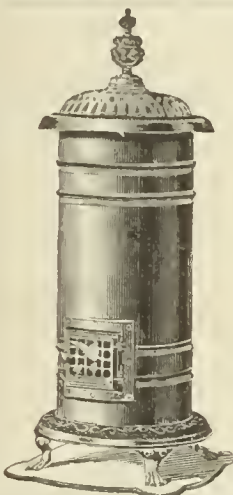

GAS STOVES

OF EVERY DESCRIPTION, FOR HEATING, COOKING, LABORATORY, AND MECHANICAL PURPOSES.

Weber Straight-Way Valves,

FOR GAS, STEAM, AND WATER.

Send for Catalogue "C."

Correspondence Solicited.

THE COMBINATION GAS MACHINE CO.,

Detroit, Mich.

Windsor, Ont.

163 Maiden Lane, N. Y. City. 87 Dearborn St., Chicago, Ill.



CONE GAS STOVE

FOR HEATING rooms of any size. Perfect combustion. No injurious odors to be carried away by a chimney. Warranted odorless, or the purchase money refunded. DINSMORE MFG. CO., 28 Kneeland Street, Boston, Mass. Send for Catalogue.

BOOKS.

DISTILLATION OF COAL TAR AND AMMONIACAL LIQUOR.

By GEORGE LUNGE. Price \$12.50.

A TREATISE ON THE COMPARATIVE COMMERCIAL VALUES OF GAS COALS AND CANNELS.

By DAVID A. GRAHAM. 8vo., Cloth. Price \$3.

Orders for these books may be sent to this office.

A. M. CALLENDER & CO.,

42 PINE ST., N. Y. CITY.

Ferric Oxide for Gas Purification.

Ferric Oxide, as ground, screened, and prepared by me for purifying purposes, has now been in use for several years by many of the gas works throughout the country, including Detroit, Chicago, Milwaukee, East Saginaw, Burlington (Iowa), Ann Arbor, etc. It has proved, as I believe, the **Most Effective and Economical Agent** now in use. I am prepared to furnish the Oxide by the 100 lbs. or in car load lots, and will be pleased to give price f.o.b. cars at Ann Arbor or at place of destination. Address

S. H. DOUGLAS, Prest. Ann Arbor (Mich.) Gas Light Co.

GAS AND WATER PIPES.

GAS AND WATER PIPES.

ENGINEERS.

SAM'L R. SHIPLEY, Pres.
HENRY B. CHEW, Treas.

JAS. P. MICHELLON, Sec.
WM. SEXTON, Supt.

P. D. WANNER, Chairman. A. H. MELLERT, Sec. & Treas.

GLOUCESTER IRON WORKS,
GLOUCESTER CITY, N. J.

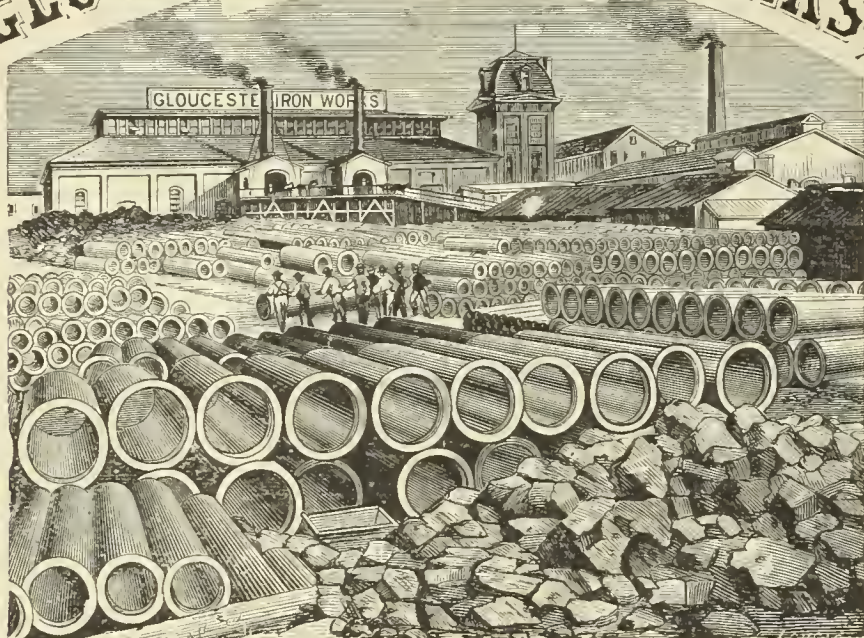

Cast Iron Gas & Water Pipes, Stop Valves, Fire Hydrants, Gasholders. &c.

Office No. 6 North Seventh Street, Philadelphia.

MATTHEW ADDY, President.

W. L. DAVIS, Selling Agent.

GEO. P. WILSHIRE, Sec. & Treas.

Cincinnati and Newport Iron and Pipe Company,
NEWPORT, KY.

Lamp Posts
AND
BENCH CASTINGS

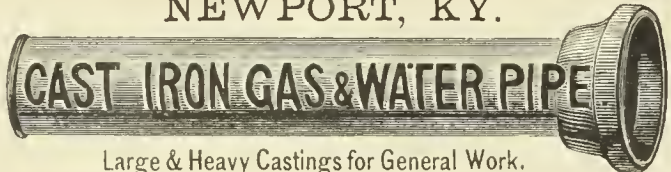

Branch
AND
SPECIAL CASTINGS

A Specialty.

Large & Heavy Castings for General Work.

FOR GAS & WATER CO'S

Manufacture Pipe from 2 to 48 inches. All work guaranteed first quality.

Pancoast & Rogers.

WROUGHT IRON PIPE,

VALVES AND GATES,

Cast Iron Gas & Water Pipe.

28 Platt and 15 Gold St., New York.

Water & Gas Pipe.

RUSTLESS

Send for New Catalogue.

RUSTLESS

The WELLS RUSTLESS IRON COMPANY,

Nos. 7 and 9 Cliff Street, New York City.

The Management of Small Gas Works.

By C. J. R. HUMPHREYS. Price, \$1.

A running commentary on the different sections of gas management with reference to small undertakings, with some notes on the erection of the necessary plant.

A. M. CALLENDER & CO., 42 Pine St., N. Y.

MELLERT FOUNDRY & MACHINE CO., Ltd.

Reading, Pa.



Specials—Flange Pipe, Valves and Hydrants, Lamp Posts, Retorts, etc.

General Foundry and Machine Work.

JOHN FOX, Selling Agent. 160 Broadway, N. Y.

THE OHIO PIPE COMPANY,

MANUFACTURERS OF

Cast Iron Gas & Water Pipe,

BRANCH AND SPECIAL CASTINGS.

Gas-House Bench Castings, Hydraulics, Lamp Posts, Flange Pipe and Specials, Architectural Castings, Building Columns, Joists, Cellar Grates, Sash Weights, etc.

GENERAL FOUNDERS AND MACHINISTS.

Columbus, Ohio.

M. J. DRUMMOND,



SPECIAL CASTINGS AND LAMP POSTS.
Equitable Building, 120 Broadway, N. Y.

JOS. R. THOMAS, C.E.,

May be Consulted on all Matters Relating to Gas Works and Gas Manufacture.

ADDRESS THIS OFFICE.

WM. MOONEY

(Successor to WM. FARMER)

27 Pearl Street, N. Y. City.

(One door from Whitehall Street.)

CONTRACTOR FOR THE ERECTION OF GAS WORKS, OR APPARATUS OF ANY CAPACITY. AGENT FOR WM. FARMER'S PATENTS.

Plans and Specifications Furnished.

WM. HENRY WHITE,

CONSULTING AND CONSTRUCTING

Gas Engineer & Contractor

Estimates, Plans, and Specifications furnished for new works or extensions of existing works.

No. 32 Pine Street, New York City.

Correspondence solicited.

WM. GARDNER,

Gas Engineer,

Lewis Block, Room 20, Pittsburgh, Pa.

Those who intend to make alterations in existing gas plants, or who contemplate the erection of new works, will find it to their interest to open correspondence with the above. Plans made and estimates furnished.

GAS LAMPS.

SCRUBBERS AND CONDENSERS.

The Siemens and Lungren REGENERATIVE GAS LAMPS.

A System of Burning Gas whereby its Illuminating Power is Increased from 300 to 400 per ct. without the Expense, Trouble and Annoyance resulting from the use of Hydrocarbon Enriching Material.

The Siemens-Lungren Company received the only Silver Medal or Highest Award for Gas Burners at the "Novelties" Exhibition of the Franklin Institute, held at Phila., Oct., '85.

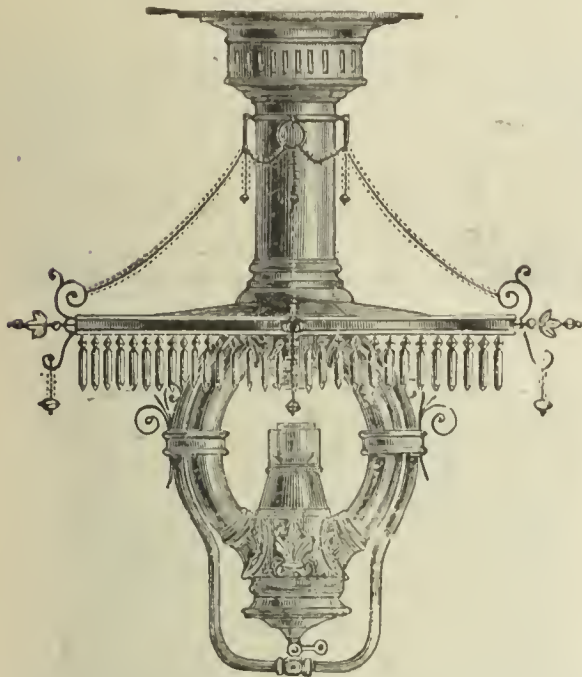

SIEMENS LAMP.

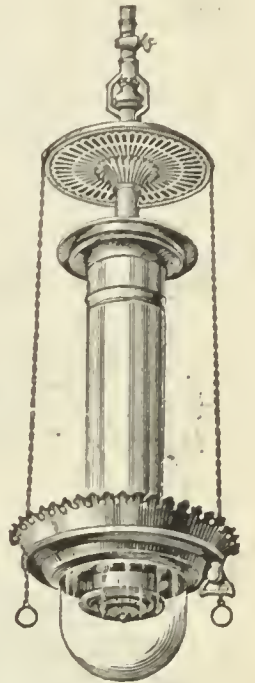

LUNGREN LAMP

THIRTEEN CANDLE POWER PER CUBIC FOOT OF GAS!

This result is obtained

SIMPLY BY THE SCIENTIFIC APPLICATION OF THE REGENERATIVE PRINCIPLE.

Consequently this largely increased illumination is always maintained without further cost and frequent attention.

THE SIEMENS-LUNCREN COMPANY,

N. E. Cor. 21st. St. and Washington Av., Phila. Pa.

KIRKHAM, HULETT & CHANDLER, Limited,
London, S. W., England.

PATENT "STANDARD" WASHER-SCRUBBERS.

Following are extracts from letters received from some of the Gas Light Companies now using the "Standard" Washer-Scrubber:

SAN FRANCISCO, Sept. 21, 1887.

GEO. SHEPARD PAGE, Esq.:

Dear Sir—In reply to yours, would say that the ammonia is entirely removed from the gas by the use of the "Standard" Washer-Scrubber.

Yours truly, J. B. CROCKETT, Prest.,
San Francisco Gas Lt. Co.

BOSTON, MASS., Aug. 30, 1887.

GEO. SHEPARD PAGE, Esq.:

Dear Sir—The "Standard" Washer-Scrubber at these works is giving good satisfaction, and the increased amount of ammonia eliminated from the gas by its use enables us to obtain a larger income from the ammoniacal liquor.

Truly yours, THOS. J. PISHON, Supt.,
Roxbury Gas Lt. Co.

GEORGETOWN, D. C., Sept. 27, 1887.

GEORGE SHEPARD PAGE, Esq.:

Dear Sir—The "Standard" Washer-Scrubber, together with all the work of connecting the same with these works, has given entire satisfaction.

Truly yours, J. B. CATHELL, Supt.,
Georgetown Gas Lt. Co.

BROOKLYN, N. Y., Sep. 8, 1887.

GEORGE SHEPARD PAGE, Esq.:

Dear Sir—By the use of the "Standard" Washer-Scrubber at these works the ammonia is entirely removed from the gas, and our income from the ammoniacal liquor has been increased 100 per cent.

Yours truly,
C. W. BLODGET, Sec.,
Williamsburgh Gas Lt. Co.

GEO. SHEPARD PAGE, 69 WALL STREET, NEW YORK,

Agent for the Western Hemisphere.

GAS WORKS APPARATUS AND CONSTRUCTION.

GAS WORKS APPARATUS AND CONSTRUCTION.

WORKS: { MILLVILLE, N. J.
FLORENCE, "
CAMDEN, "

R. D. WOOD & CO.,

OFFICES: { 400 CHESTNUT ST.,
PHILADELPHIA.

CAST-IRON PIPE 1½ to 72 Inches in Diameter.

Water Machinery and Gas Apparatus.

HEAVY CASTINGS.

HOLDERS,

PURIFIERS,

FLOORS AND ROOFS,

LAMP POSTS,

CONDENSERS,

FLANGED PIPE,

VALVES,

BENCH WORK,

FIRE HYDRANTS,

METER CASES.

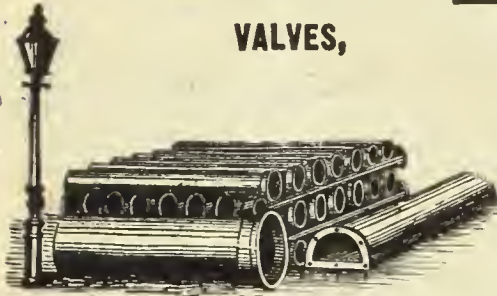

Estimates and Specifications for
NEW WORKS or **EXTENSIONS**
or **ALTERATIONS** of **OLD ONES.**

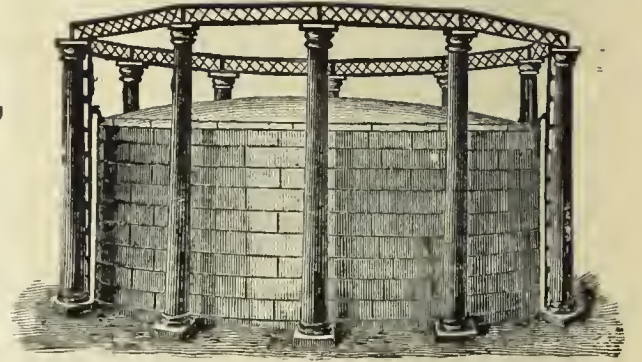

GASHOLDER TANK CONSTRUCTION, ETC.

Gas Companies and others about to erect Gasholders will find it profitable to consult W. C. WHYTE, who for over thirty years has made a specialty of

Holder Tank Excavation and Mason Work.

Fifty tanks now in operation show the sort of work done. Address

W. C. WHYTE, No. 15 Cortlandt St., N. Y. City.

MORRIS, TASKER & CO.,

Limited,

Builders of Gas Works,

PHILADELPHIA PA.

FOR

GAS WORKS APPARATUS

AND

GASHOLDERS,

ADDRESS

KERR MURRAY MANUFACTURING COMPANY,

FORT WAYNE, IND.

A. D. CRESSLER, Gen'l Mangr.

GAS WORKS APPARATUS AND CONSTRUCTION.

GAS WORKS APPARATUS AND CONSTRUCTION.

JAMES R. FLOYD,

(SUCCESSOR TO HERRING & FLOYD)

Oregon Iron Works,

531 to 543 West 20th St., N. Y.

Practical Builders of Gas Works.

MANUFACTURERS OF

ALL KINDS OF CASTINGS

AND

APPARATUS FOR GAS-WORKS.

BENCH CASTINGS

from benches of one to six Retorts each.

WASHERS: MULTITUBULAR AND

AIR CONDENSERS; CONDENSERS; SCRUBBERS

(wet and dry), and

EXHAUSTERS

for relieving Retorts from pressure.

BENDS and BRANCHES

of all sizes and description.

FLOYD'S PATENT

MALLEABLE RETORT LID.

PATENT

SELF-SEALING RETORT LIDS.

FARMER'S

PATENT BYE-PASS DIP-PIPE.

SABBATON'S PATENT

FURNACE DOOR AND FRAME.

BUTLER'S

COKE SCREENING SHOVELS.

GAS GOVERNORS,

and everything connected with well regulated Gas Works at low price, and in complete order.

SELLER'S CEMENT

for stopping leaks in Retorts.

N. B.—**STOP VALVES** from three to thirty inches at very low prices.

Plans, Specifications, and Estimates furnished.

THE CONTINENTAL IRON WORKS.

THOS. F. ROWLAND, Prest. WARREN E. HILL and CHAS. H. CORBETT, V.-Prests. THOS. F. ROWLAND, JR., Sec. & Treas.



GAS HOLDERS OF ANY MAGNITUDE.

P. O. Station G., BROOKLYN, N. Y.

ENGINEERS AND MANUFACTURERS OF

Gas Holders

CONDENSERS, SCRUBBERS, VALVES,

PURIFIERS, SELF-SEALING RETORT LIDS,

Hydraulic Mains,

And all other articles connected with the manufacture and distribution of Gas.

H. RANSHAW, Prest. & Mangr WM. STACEY, Vice-Prest. T. H. BIRCH, Asst. Mangr. R. J. TARVIN, Sec. & Treas.

STACEY MFG. CO.,

MANUFACTURERS OF

Single and Telescopic Gasholders,

IRON ROOFS, BRIDGES, LAMP POSTS,

Water and Oil Tanks, Coal Elevator Cars,

COKE CRUSHERS, BENCH CASTINGS,

And all kinds of Wrought and Cast Iron Work used in the erection of Coal and Oil Gas Works. Rolling Mill Machinery and Heavy Castings a Specialty.

Foundry:

33, 35, 37 & 39 Mill Street.

Wrought Iron Works:

16, 18, 20, 22, 24 & 26 Ramsey Street:

Cincinnati, Ohio.

Bouton Foundry Co.,

FOUNDERS AND MACHINISTS,

CHICAGO, ILL.

Gas Works Apparatus,

PURIFIERS, CONDENSERS,

Bench Work,

SPECIALS, LAMP POSTS,

SCRUBBERS,

Iron Roofs and Floors.

Plans and Estimates furnished for new works or extensions of old works.

1842. **DEILY & FOWLER,** 1887.
Laurel Iron Works.

Address, No. 39 Laurel Street, Philadelphia, Pa.

MANUFACTURERS OF

GASHOLDERS,

Single and Telescopic.

HOLDERS Built 1882 to 1886, Inclusive:

- | | | | | |
|----------------------------|--------------------------|----------------------------|-----------------------------|---------------------------|
| Denver, Col. | Warren, Ohio. | Allegheny, Pa. (21.) | York, Pa. | Salem, N. J. (3d) |
| Chicago, Ill. (West Side). | Bath, N. Y. | Atlanta, Ga. (2d.) | Chester, Pa. | Omaha, Neb. (2d) |
| Pittsburgh, Pa. (S. Side) | Lynn, Mass. | N.Y. City (Central Gas Co) | Hazleton, Pa. (2d.) | Lynn, Mass. (2d) |
| Pawtucket, R. I. | New Bedford, Mass. | Lynchburg, Va. (2d.) | State Island, N. Y. | Little Rock, Ark. |
| Brookline, Mass. | Waterbury, Conn. | Saylesville, R. I. | Saugerties, N. Y. | Irvington, N. Y. |
| Sherbrooke, Can. | Deseronto, Can. | Rondout, N. Y. | Clinton, Mass. (Lan. Mills) | South Boston, Mass |
| Burlington, N. J. (2d) | Hopsc Falls, N. Y. (2d.) | Atlantic City, N. J. | Chattanooga, Tenn. | Rye, N. Y. (2) |
| Bridgeton, N. J | Bethlenem, Pa. | Augusta, Ga. | Galveston, Texas. (3d.) | Woodstock, Ont. |
| Bay City, Mich. | Atlanta, Ga. (1st.) | Waltham, Mass. (2) | Omaha, Neb. | Malden, Mass. |
| Erie, Pa. | Savannah, Ga. | Mahanoy City, Pa. | Fort Plain, N. Y. | Staten Island, N. Y. (2d) |
| Jackson, Mich. | Montgomery, Ala. | New Castle, Pa. | Brunswick, Ga. | |
| Kalamazoo, Mich. (3d.) | Newport, R. I. | Long Island City, N. Y. | Port Chester, N. Y. | |
| Glen Island, N. Y. | Portland, Oregon. | Macon, Ga. | New Rochelle, N. Y. | |

SMITH & SAYRE MFG. COMPANY,

G. G. PORTER, Prest.

245 Broadway, N. Y.

CHAS. W. ISBELL, Sec'y.

Machinery & Apparatus for Gas Works

Drawings, Plans, and Estimates Furnished for the Improvement, Extension, or Alteration of Gas Works, or for the Construction of New Works.

Mackenzie's Patent Rotary and Steam Jet Gas Exhausters, Governors, Compensators, Condensers, Washers, Scrubbers. Isbell's Patent Automatic Street Pressure Governor, Gas and Water Valves, Hydraulic Main Dip Regulator, Bench Castings, etc. Purifying Boxes and "Standard" Scrubbers. Isbell's Patent Self-Sealing Retort Doors.

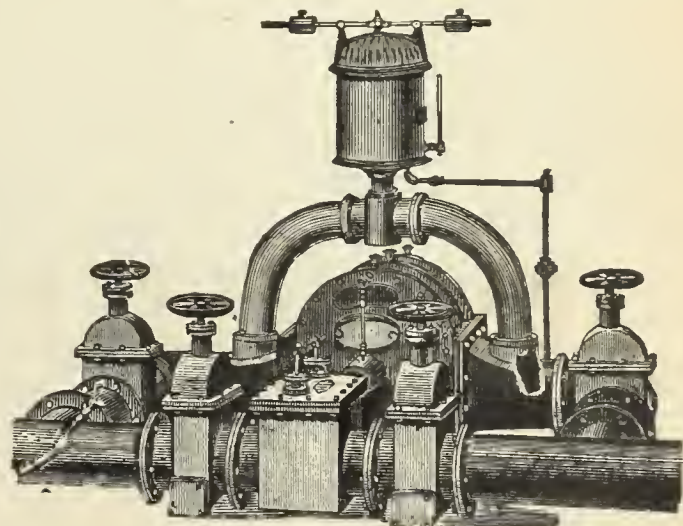

GAS COALS.

CANNEL COALS.

GAS ENRICHERS.

JAMES D. PERKINS.

PERKINS & CO.,

F. SEAVERNS.

General Sales Agents for

The Youghioghenny River Coal Company's

OCEAN MINE YOUGHIOGHENY GAS COAL.

The Coal from the Ocean Mine (recently operated by *Messrs. W. L. Scott & Co.*, of Erie, Pa.,) is now used by all the leading Gas Companies in the United States from Maine to Texas, and is recognized as *the only reliable Youghioghenny Gas Coal.* (See Map on p. 87 of this Journal, Feb. 16, '85.)

P. O. Box 3695,
New York

PERKINS & CO., 228 and 229 N. Y. Produce Exchange,

**BEAVER STREET
ENTRANCE.**

**BRECKENRIDGE CANNEL,
OF KENTUCKY.**

This Colliery was re-opened in June, 1886, since which date the Cannel has been delivered to over sixty of the leading Gas Companies in this country and in Europe. As an enricher ONE TON of this Cannel will do the work of TWO TONS of any other available Cannel, and is more economical than Naptha or Oil of any character. It can be delivered in parcels of one car load or more to any point in the United States or Canada.

(See AMERICAN GAS LIGHT JOURNAL, June 16, '86, pp. 346-7.)

P. O. Box 3695,
New York.

PERKINS & CO., 228 and 229 N. Y. Produce Exchange

**BEAVER STREET
ENTRANCE.**

JAMES & WILLIAM WOOD,

Gas and Cannel Coal Contractors,

No. 40 St. Enoch Sq., Glasgow. No. 2 Talbot Court, London.

Proprietors of the **BATHVILLE COLLIERIES** (which produce the celebrated **BOGHEAD CANNEL**), Shields, Shieldmuir, Drumpeller, and other Collieries. This Firm offer

STANDARD CANNELS,

Unequaled as Gas Enrichers.

Analyses, prices, and all further information furnished on application to

Agency for U. S., Room 93, Nos. 2 & 4 Stone St., N.Y. City.

The Standard Oil Company,

REFINERS OF

NAPTHA AND GASOLINES.

ALSO MANUFACTURERS OF

A Special Grade of Naptha for Gas Companies

FOR ENRICHING COAL GAS.

Correspondence solicited.

No. 43 Euclid Avenue, Cleveland, Ohio.

To Gas Companies.

We make to order **CAP BURNERS** to burn any amo under a stated pressure. Send for samples.

Also, **SERVICE CLEANERS, DRIP PUMPS, and STRE MAIN PROVING APPARATUS.**

C. A. GEFRORER,

248 N. 8th Street, Phila., Pa.

GOODWIN'S DIRECTORY

OF THE GAS LIGHT COMPANIES of the UNITED STATES & CANADA.

Price, \$3.00.

Orders may be sent to

A. M. CALLENDER & CO., No. 42 Pine Street, N. Y. City.

COKE CRUSHERS.

GAS COALS.

GAS COALS.

Newburgh Orrel Coal and Coke Co.

MINERS AND SHIPPERS OF

Mountain Brook Steam and Smithing Coals,

**NEWBURGH, PALATINE,
AURORA & TYRCONNELL
GAS COALS.**

Foundry & Crushed Coke Shipped Direct from Ovens
Mines Situated at

Newburgh, Flemington & Fairmont, W.Va.

HOME OFFICE,

33 S. Gay St., Baltimore.

CHAS. MACKALL, Gen. Mangr.

CHAS. W. HAYS, Agent in New York,

Room 147, WASHINGTON BUILDING, No. 1 Broadway.

Shipping wharves at Locust Point, Baltimore.

THE DESPARD COAL COMPANY

OFFER THEIR SUPERIOR

DESPARD COAL

To Gas Light Companies and Manufacturers of Fire Clay Goods
Throughout the Country.

ROUS EL & HICKS, } AGENTS. { BANGS & HORTON,
71 Broadway, N. Y. } 16 Kilby St., Boston.

Mines in Harrison Co., West Va. Wharves, Locust Point, Balt.

Company's Office, 15 German St., Baltimore, Md.

Among the consumers of Despard Coal we name: Manhattan
Gas Light Co., N. Y.; Metropolitan Gas Light Co., N. Y.; Jersey
City, (N. J.) Gas Light Co.; Washington (D. C.) Gas Light Co.;
Portland (Maine) Gas Light Co. Reference to them is requested.

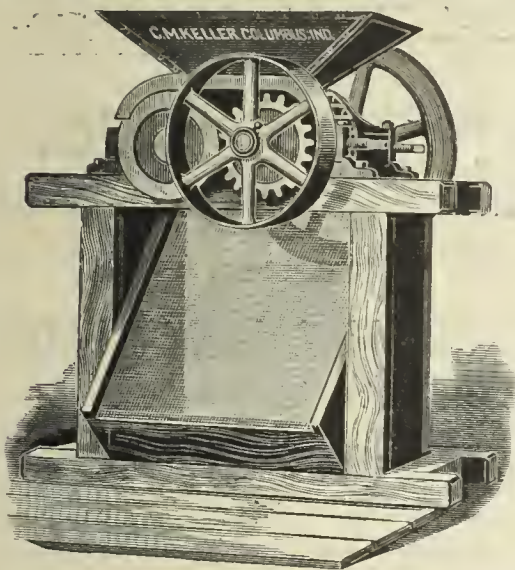

Keller's Adjustable Coke Crusher

SIMPLE, STRONG, AND DURABLE.

C. M. Keller, Sec. & Supt. Gas Lt. & Coke Co. Columbus, Ind.

Correspondence Solicited.

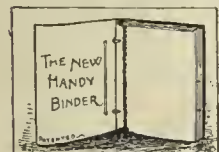

**THE NEW
HANDY BINDER.**

This article may be described as elegant in appearance, strong, durable, and possessing many special qualities of its own. It allows the opening of the pages perfectly flat, whether one or several numbers are in the binder. Any number can be taken out and replaced without disturbing the others. The papers are not mutilated for subsequent binding in permanent form. The binder is supplied with gilt side title, and is an ornament to any desk or reading table. The JOURNAL, filed in the Handy Binder, becomes a volume of great value, always convenient for instant reference. Handy Binder, Postage paid, \$1.00.

A. M. CALLENDER & CO., 42 Pine St., N. Y.

**THE
PENN GAS COAL CO.**

OFFER THEIR

Coal, Carefully Screened & Prepared for Gas Purposes

Their Property is located in the Youghiogheny Coal Basin, near Irwin and Penn Stations on the Pennsylvania Railroad, and on the Youghiogheny River.

Principal Office:

209 SOUTH THIRD STREET, PHILA., PA.

Points of Shipment:

Pennsylvania Railroad Piers; Greenwich Wharves, Delaware River; Pier No. 1 (Lower Side), South Amboy, N. J.

Chesapeake & Ohio Railway Coal Agency,

FOR THE SALE OF THE

**Superior Kanawha Gas Coals, Cannelton Cannel,
Also, SPLINT AND STEAM COALS.**

From the Kanawha and New River Regions, on the line of the Chesapeake & Ohio R'way.

C. B. ORCUTT, Sales Agent. | OFFICE, 150 BROADWAY, N. Y.

FRANCIS H. JACKSON, Prest. EDMUND H. MCCULLOUGH, V.-Prest. CHAS. F. GODSHALL, Treas. H. C. ADAMS,

THE WESTMORELAND COAL CO.

Chartered 1854.

Mines situated on the Pennsylvania and the Baltimore and Ohio Railroads, in Westmoreland County, Penn.

POINTS OF SHIPMENT:

PHILADELPHIA, BALTIMORE, SOUTH AMBOY, N. J.,
WATKINS (SENECA LAKE), N. Y.

Since the commencement of operations by this Company its well-known Coal has been largely used by the Gas Companies of New England and the Middle States, and its character is established as having no superior in gas giving qualities, and in freedom from sulphur and other impurities.

Principal Office, 224 South 3d St., Phila., Pa.

A. M. SCOTT, PRESIDENT. A. DEMPSTER, C.E., SECRETARY. W. K. GILLESPIE, TREASURER.

MONONGAHELA AND PETERS CREEK GAS COAL CO.,

PRODUCERS OF

Coal Bluff Gas Coal.

MINES LOCATED ON THE MONONGAHELA DIVISION OF THE PENNSYLVANIA RR.,
IN THE CENTRAL PORTION OF THE PITTSBURGH COAL FIELD.

Points of Shipment—Buffalo, Cleveland, Erie, Chicago, New Orleans.

Since the introduction of Coal Bluff Gas Coal it has taken rank among the few first-class Gas Coals, and acknowledges no superior in gas-giving qualities, ease of working, quality of coke, and freedom from impurities.

General Office, 43 Sixth Ave., Pittsburgh, Pa.

GAS METERS.

GAS METERS.

GAS METERS.



INTERNATIONAL--1876--EXHIBITION.

The U. S. Centennial Commission

HAVE DECREED AN AWARD TO

HARRIS, GRIFFIN & CO.,

Twelfth and Brown Streets, Philadelphia, Pa. No. 49 Dey Street, N. Y. City, and No. 75 North Clinton Street, Chicago, Ill.

FOR THE FOLLOWING REASONS:

The Exhibit consists of a Series of METERS from the Largest Size Station Meters for the use of the MANUFACTURE OF GAS, to those for the use of the ORDINARY CONSUMER. The Instruments are WELL MADE, RELIABLE as to INDICATION, and embody a number of sundry improvements which, with the general character of the Exhibit, entitle the whole to commendation.

Attest—J. L. CAMPBELL,
Secretary, pro-tem.

Signed—A. T. GOSHORN,
Director General

J. B. HAWLEY,
President



Dry Gas Meter.

With 39 years' experience and the best facilities for manufacturing, is enabled to furnish reliable work and answer orders promptly.

NATHANIEL TUFTS,*No. 153 Franklin Street, Boston, Mass.,*

MANUFACTURER OF

DRY GAS METERS.

Station Meters of any Capacity.

Test and Experimental Meters, Pressure Registers, Pressure Gauges, Pressure and Vacuum Gauges.

METER PROVERS, PHOTOMETERS, STREET LANTERNS, ETC., ETC.

Patent Cluster Lanterns for Street Illumination.

CHARLES E. DICKEY.

JAMES B. SMALLWOOD.

CHARLES H. DICKEY.

Maryland Meter and Manufacturing Co.,

307 and 309 Saratoga Street, Baltimore, Md. 195 and 197 Michigan Street, Chicago, Ill.

1115 Olive Street, St. Louis, Mo.

MANUFACTURERS OF

DRY GAS METERS, STATION METERS, GLAZED METERS, TEST METERS, METER PROVERS, PRESSURE & VACUUM REGISTERS,

Governors, Indicators, Service and Meter Cocks, and Meter Connections.

"SUCCESS" GAS RANGES.

Meter Repairing a Specialty.

SCIENTIFIC BOOKS.

We are prepared to furnish to Gas Managers, and others interested in the topics treated of, the following books, at prices named:

KING'S TREATISE ON THE MANUFACTURE OF COAL GAS. Three vols.; \$10 per vol.	PRACTICAL TREATISE ON HEAT, by THOMAS BOX. Second edition. \$5.	THE GAS MANAGER IN THE LABORATORY, by a Practical Student. 8vo., Cloth. \$1.50.
GAS MANUFACTURE, by WILLIAM RICHARDS. 4to., with numerous Engravings and Plates, in Cloth binding. \$12.	GAS WORKS—THEIR ARRANGEMENT, CONSTRUCTION, PLANT, AND MACHINERY. \$8.	THE DOMESTIC USES OF COAL GAS, AS APPLIED TO LIGHTING, by W. SUGG. \$1.40.
THE GAS ANALYST'S MANUAL, by F. W. HARTLEY. \$2.50.	COAL; ITS HISTORY AND USE, by PROF. THORPE. \$3.50.	DISTILLATION OF COAL TAR AND AMMONIACAL LIQUOR by GEO. LUNGE. New Edition. \$12.50.
TECHNICAL GAS ANALYSIS. \$2.80.	THE GAS WORKS OF LONDON, by COLBURN. 60 cents.	A TREATISE ON THE COMPARATIVE COMMERCIAL VALUES OF GAS COALS AND CANNELS, by D. A. GRAHAM 8vo., Cloth. \$3.
GAS MANAGER'S HANDBOOK, by THOS. NEWBIGGING. \$4.80.	THE GAS FITTER'S GUIDE, Showing the Principles and Practice of Lighting with Coal Gas, by JOHN ELDREDGE. 40 cents.	GAS COMPANIES DIRECTORY. \$3.
GAS CONSUMER'S GUIDE. \$1.	GAS WORKS, AND MANUFACTURING COAL GAS, HUGHES. \$2.20.	GAS VERSUS ELECTRIC LIGHT. 50 cents.
A GUIDE TO GAS LIGHTING. 40 cents.	THE MANAGEMENT OF SMALL GAS WORKS, by C. J. R. BUMPHEYS. \$1.	PURIFICATION OF COAL GAS, by R. P. SPICE. 8vo. \$3.
GAS MEASUREMENT AND GAS METER TESTING, by F. W. HARTLEY. \$1.60.	MANUAL FOR GAS ENGINEERING STUDENTS, by D. LEE, 40 cents.	
GAS CONSUMER'S HANDBOOK, by WILLIAM RICHARDS, C.E.; 18mo., Sewed. 20 cents.	HOW TO MANAGE GAS, by F. WILKINS. Paper. 20 cents.	
A PRACTICAL TREATISE ON GAS AND VENTILATION with Special Relation to Illuminating, Heating, and Cooking by Gas, by E. E. PERKINS. \$1.25.		

The above will be forwarded by express, upon receipt of price. We take especial pains in securing and forwarding any other Works that may be desired, upon receipt of order. All remittances should be made by check, draft, or post office money order.

A. M. CALLENDER & CO., No. 42 Pine Street, New York.

GAS METERS.

GAS METERS.

GAS METERS.

GEO. J. MCGOURKEY, Pres.

WM. H. MCFADDEN, Vice-Pres. (Phila.).

WM. N. MILSTED, Gen. Supt. & Treas. (New York).

WM. H. DOWN Sec.

AMERICAN METER COMPANY.

WET AND DRY GAS METERS.

PRESSURE REGISTERS.

METER PROVERS.

STATION METERS.

PRESSURE & VACUUM REGISTERS.

PORTABLE TEST METERS.

EXHAUSTER GOVERNORS.

PRESSURE & VACUUM GAUGES.

EXPERIMENTAL METERS.

DRY CENTRE VALVES.

CRESSON GAS REGULATORS.

AMMONIA TEST METERS.

GOVERNORS FOR GAS WORKS.

MARSLAND WATER METERS.

BAR AND JET PHOTOMETERS.

Manufactories:

512 W. 22d St., N. Y.
Arch & 22d Sts., Phila.

GAS STOVES,

SUGG'S "STANDARD" ARGAND BURNERS,
SUGG'S ILLUMINATING POWER METER,
Wet Meters, with Lizar's "Invariable Measuring" Drum.

Agencies:

177 Elm Street, Cincinnati.
214 & 216 N. Wells Street, Chicago.
810 North Second Street, St. Louis.
222 Sutter St., San Francisco.

HELME & McILHENNY,

(Established 1848.)

GAS METER MANUFACTURERS,

Nos. 1339 to 1349 Cherry Street, Philadelphia, Pa.,

WET AND DRY GAS METERS, STATION METERS, EXPERIMENTAL METERS, METER PROVERS,

Center Seals, Pressure Registers, Governors, Indicators, Photometers, and all other kinds of Apparatus for use in Gas Works.

FOULIS' PATENT STATION AND DISTRICT GOVERNORS.

REPAIRING DEPARTMENT.—We employ a special force of skilled workmen repairing meters of all makers.

WM. WALLACE GOODWIN, Pres. and Treas.

WM. H. MERRICK, V.-Pres.

S. L. JONES, Sec.

S. V. MERRICK, Supt.

THE GOODWIN GAS STOVE AND METER COMPANY,

Successors to W. W. GOODWIN & CO.

1012, 1014 and 1016 Filbert St., Phila., Pa.

142 Chambers St., New York.

76 Dearborn St., Chicago, Ill.

WALDO BROS., Agents, 88 Water St., Boston.

MANUFACTURERS OF THE "SUN DIAL" GAS STOVES, FOR COOKING AND HEATING PURPOSES.

Dry and Wet GAS METERS, Station Meters (Square, Cylindrical or in Staves) Glazed Meters, King's and Sugg's Experimental Meters, Lamp Post Meters, Etc., Etc., Meter Provers (sizes 2, 5 and 10 feet), Pressure Gauges of all kinds, Pressure Registers, Pressure and Vacuum Registers, Pressure Indicators (sizes 4 inch, 6 inch and 9 inch), King's Pressure and Vacuum Gauges, Dry and Wet Centre Seals, Dry and Wet Governors, Exhauster Governors, Photometers of all descriptions. Letheby's Sulphur and Ammonia Test Apparatus complete—also Testing and Chemical Apparatus of all kinds, and of the most perfect description, for all purposes relating to Gas.

GOODWIN'S IMPROVED LOWE'S JET PHOTOMETER.

Agents for Bray's Patent Gas Burners and Lanterns.

Special attention to repairs of Meters, and all apparatus connected with the business.
All work guaranteed first class in every particular, and orders filled promptly.

G. B. EDWARDS, Mang'r, New York.
E. H. B. TWINING, Mang'r, Chicago.
Represented by S. S. STRATTON.

D. McDONALD & CO.,

GAS METER MANUFACTURERS.

(Established 1854.)

51 Lancaster St., Albany, N. Y.

34 & 36 West Monroe St., Chicago, Ill.

STATION METERS, EXPERIMENTAL METERS, METER PROVERS, PRESSURE & VACUUM REGISTERS, PRESSURE GAUGES, ETC.

Also STAR GAS STOVES, RANGES, and HEATING STOVES.

We use only the very best materials, and employ the most skilled labor, and by our long experience (32 years) and personal supervision of every detail, we feel justified in assuring the public that our goods will give perfect satisfaction. Every Meter emanating from our establishment will bear the State Inspector's BADGE, and will be fully warranted by us. Our Annual and Calendar will be sent to Gas Companies upon application.

Gas into Electricity

—BY THE—

OTTO GAS ENGINES.

Gas Companies are given by the Otto Gas Engine superior means for Production of Power and Electric Light.

We refer to the following large sized Engines in practical use since some time:

Spencer Gas Company, Spencer (Mass.).....	3 Engines,	45 Horse Power.	Electric Light Plant.
Washington Gas Company, Washington (Davies Co., Ind.).....	1	" 25	" " " " " " " "	" " " "
Nashua Gas Company, Nashua (N. H.).....	1	" 15	" " " " " " " "	" " " "
Borough of Stamford, Stamford (Conn.) ...	3	" 15	" " " " " " " "	... Sewage Works.
" El Paso, El Paso (Texas).....	(In course of erection.)			
Gas Company, Prague (Austria).....	3 Engines,	150 Horse Power.	Electric Light Plant.
" " Carlsbad (Bohemia).....	2	" 60	" " " " " " " "	" " " "
" " Frankfort-on-the Main (Germany).....	2	" 100	" " " " " " " "	" " " "
" " Coblenz (Germany).....	3	" 120	" " " " " " " "	... City Water Works.
" " Duren (Germany).....	2	" 80	" " " " " " " "	" " " "

The economical results attending Gas Power have caused many industrial establishments to manufacture Gas by their own Gas Plants, and to discard Steam and Boilers. With suitable apparatus a FUEL CONSUMPTION has been reached equivalent to TWO POUNDS PER ACTUAL HORSE POWER per hour. Such plants are used by the following firms:

William Grillo's Zinc Rolling Mill, Oberhausen (Germany).....	10 Engines,	244 Horse Power.		
Russian Powder Manufacturing Company, Schlüsselburg.....	17	" 194	" " " " " " " "	" " " "
Pfeifer & Lanen, Beet Sugar Factory, Elsdorf (Germany).....	6	" 191	" " " " " " " "	" " " "
Mining Company of Metternich, Metternich (Germany).....	7	" 174	" " " " " " " "	" " " "
M. H. Wilkens & Sons, Silverware, Hemelingen (Germany).....	3	" 77	" " " " " " " "	" " " "
The Beet Sugar Manufacturing Company, of Baden, Waghäusel (Germany).....	1	" 60	" " " " " " " "	" " " "

—AND OTHERS—

ADVANTAGES to Gas Companies combining Gas with Electric Lighting over those furnishing Electric Lighting only.

Economy in Fuel. Economy in Cost of attendance to Power Plant. Consumption of Fuel being limited to time of lighting. Possibility of multiplying stations and of avoiding loss by resistance in electric wires, gas passing through pipes freely. Economy in expense of administration. First cost of Plant reduced by dispensing with boiler house, boiler settings, smokestack, coal sheds, etc. No smoke nuisance. No boiler explosions. Low rates of insurance.

“Otto Gas Engine Works,”

SCHLEICHER, SCHUMM & CO.,

130 Washington Street, Chicago.

33d and Walnut Sts., Philadelphia.

NEW YORK AGENCY, 18 VESEY STREET.

