

UC-NRLF



QB 243 412

STEEL AND IRON



WILLIAM H. GREENWOOD

BERKELEY

LIBRARY

UNIVERSITY OF
CALIFORNIA

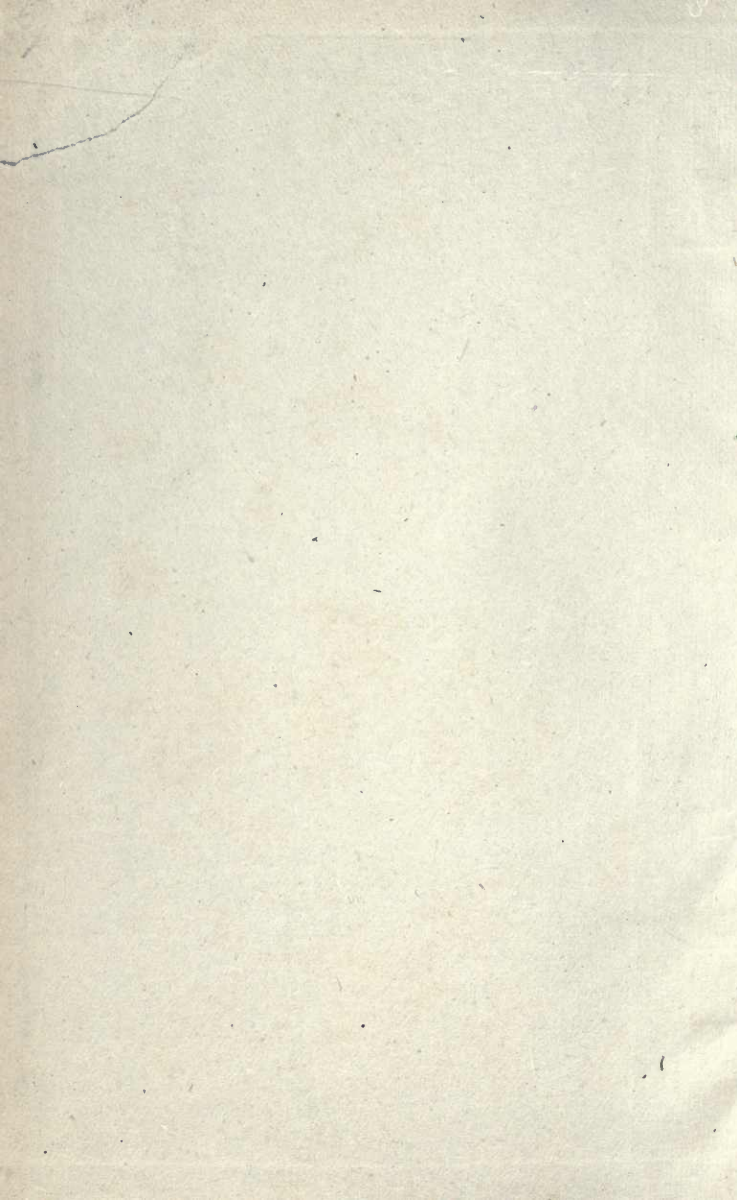

MANUALS OF TECHNOLOGY.

EDITED BY

PROF. AYRTON, F.R.S., and R. WORMELL, D.Sc., M.A.

MANUAL OF TECHNOLOGY

GOVERNMENT

EDITED BY A. S. W. AND R. W. W. D. S. M. A.

STEEL AND IRON:

COMPRISING THE

PRACTICE AND THEORY OF THE SEVERAL METHODS
PURSUED IN THEIR MANUFACTURE, AND OF THEIR
TREATMENT IN THE ROLLING MILLS, THE
FORGE, AND THE FOUNDRY.

BY

WILLIAM HENRY GREENWOOD,

F.C.S., Assoc. M.I.C.E., M.I.M.F.,

ASSOCIATE OF THE ROYAL SCHOOL OF MINES.

WITH 97 DIAGRAMS FROM ORIGINAL WORKING DRAWINGS.

SECOND EDITION.

CASELL & COMPANY, LIMITED:

LONDON, PARIS & NEW YORK.

[ALL RIGHTS RESERVED.]

1884.

TS305
G7
1884

P R E F A C E .



THE aim of the present work on Steel and Iron has been to produce, within moderate limits, a comprehensive Manual of practical information and of the scientific principles upon which the practice rests. The author hopes in this manner to render the book of service to the general student of the branch of Technical Science of which it treats, and also to offer to the intelligent workman a succinct statement of the scientific principles upon which depends the success of the several processes conducted or superintended by him, and upon which the construction of his plant or machinery is based. The book, therefore, is not intended to supersede the experience and practical knowledge that can be gained only in the Works, but the author hopes it will be found a useful adjunct to, and contribute to a clearer understanding of, these things.

The information has, as far as possible, been brought up to date, and for this purpose numerous articles in English and Foreign Scientific Journals and Proceedings of Societies have been consulted.

In elucidating the text, the author has preferred to use practical drawings rather than mere pictures, and he thinks that an elementary acquaintance with mechanical drawings will enable the reader to fully understand

them. Although a few of the woodcuts have been reproduced from papers in the Proceedings of learned Societies, &c., the great majority have been reduced from original working drawings of existing furnaces and plant, all drawn accurately to scale; and the author takes this opportunity to acknowledge his obligations to the numerous Ironmasters, Engineers, and others who have kindly furnished him with such drawings and assistance.

Throughout the chemical portion the nomenclature, atomic weights, and notation now universally employed have been adopted; and here also only a preliminary elementary knowledge of inorganic chemistry is required of the reader.

Within the compass of this volume, it has been impossible to enter with minute detail into the consideration of all the particulars which are necessary to make the student perfectly conversant with the whole range of the metallurgical and mechanical treatments between the iron ore and the production of the finished bar, rail, or section, but typical examples of the various operations have been described, and their details more or less fully discussed so far as scientific principles are involved.

W. H. G.

Stretford Road, Manchester.

CONTENTS.

	PAGE
CHAPTER I.	
EXPLANATION OF TERMS	1
CHAPTER II.	
REFRACTORY MATERIALS, CRUCIBLES, ETC.	14
CHAPTER III.	
THE ORES OF IRON	30
CHAPTER IV.	
METALLURGICAL CHEMISTRY OF IRON	40
CHAPTER V.	
CAST- OR PIG-IRON	61
CHAPTER VI.	
THE PRODUCTION OF PIG-IRON	79
CHAPTER VII.	
THE BLAST FURNACE. HOT-BLAST STOVES, HOISTS, LIFTS, ETC.	111
CHAPTER VIII.	
FUEL, BLAST, CHARGES, YIELD AND WASTE GASES OF THE BLAST FURNACE	168
CHAPTER IX.	
CASTINGS IN IRON, FOUNDRY APPLIANCES, ETC.	185
CHAPTER X.	
MALLEABLE OR WROUGHT IRON	202
CHAPTER XI.	
THE PRODUCTION OF MALLEABLE IRON DIRECT FROM THE ORE	211
CHAPTER XII.	
INDIRECT METHODS FOR THE PRODUCTION OF MALLEABLE IRON. THE PRODUCTION OF MALLEABLE IRON IN OPEN- HEARTH FURNACES	228

	PAGE
CHAPTER XIII.	
REFINING OF PIG-IRON, OR THE CONVERSION OF GREY INTO WHITE IRON IN THE COKE REFINERY	238
CHAPTER XIV.	
PUDDLING, OR THE PRODUCTION OF MALLEABLE IRON BY THE DECARBURISATION OF PIG-IRON IN THE REVER- BERATORY FURNACE	248
CHAPTER XV.	
MECHANICAL PUDDLING AND ROTARY PUDDLING FURNACES.	285
CHAPTER XVI.	
FORGE AND MILL MACHINERY, FURNACES, PLANT, AND OPERATIONS	300
CHAPTER XVII.	
STEEL AND INGOT IRON	384
CHAPTER XVIII.	
THE METHODS EMPLOYED IN THE PRODUCTION OF STEEL. THE PRODUCTION OF STEEL DIRECT FROM THE IRON ORE, AND BY THE CARBURISATION OF MALLEABLE OR BAR IRON.	402
CHAPTER XIX.	
THE PRODUCTION OF STEEL BY THE DECARBURISATION OF PIG-IRON IN THE FINERY OR IN THE PUDDLING FURNACE	433
CHAPTER XX.	
PRODUCTION OF STEEL BY THE FUSION OF PIG-IRON WITH MALLEABLE IRON OR WITH IRON ORES IN THE OPEN- HEARTH STEEL-MELTING FURNACE	445
CHAPTER XXI.	
THE BESSEMER OR PNEUMATIC PROCESS FOR THE PRODU- TION OF STEEL FROM PIG-IRON. THE BASIC PROCESS FOR THE CONVERSION OF PHOSPHORIC PIG-IRON INTO STEEL IN THE BESSEMER CONVERTER	460
CHAPTER XXII.	
THE PRODUCTION OF HOMOGENEOUS STEEL INGOTS, FLUID COMPRESSION OF STEEL, COMPOUND ARMOUR PLATES, ETC.	506

STEEL AND IRON.

CHAPTER I.

EXPLANATION OF TERMS.

1. CHEMICALLY pure iron exists only as a curiosity and has no practical application in the arts. It is void of commercial value as a constructive material, and cannot be prepared upon a large scale. Yet in combination with very small proportions of carbon, and almost infinitesimal proportions of other elementary bodies, as sulphur, silicon, phosphorus, &c., it yields products such as *Steel*, *Malleable* or *Wrought-iron*, and *Cast* or *Pig-iron*, which possess properties rendering them by far the most important factors in our metallurgical industries. It is with the production and working of these commercial varieties of iron that it is proposed to deal in this volume, but before proceeding to the treatment of the subject proper it may be well to offer a few remarks upon, and define once for all, the interpretation which we shall place upon certain words and phrases which are now universally used to designate special physical qualities of the metals; and upon the names given to the products obtained, and processes performed, in the metallurgical or mechanical treatment of Iron and Steel.

2. *Tenacity* is the property of resisting fracture from the application of a tensile or stretching force, and is usually stated in England in terms of the number of tons or hundredweights required to break a bar one square inch in sectional area. In France, Germany, and

generally over the Continent, the force or weight is expressed in kilogrammes (2·2046 lbs.), with the square centimetre as the unit of area (the centimetre = ·3937 inch), whilst in Russia the units often employed to express the pressure and the sectional area are the atmosphere (about 15 lbs.) and the square inch respec-

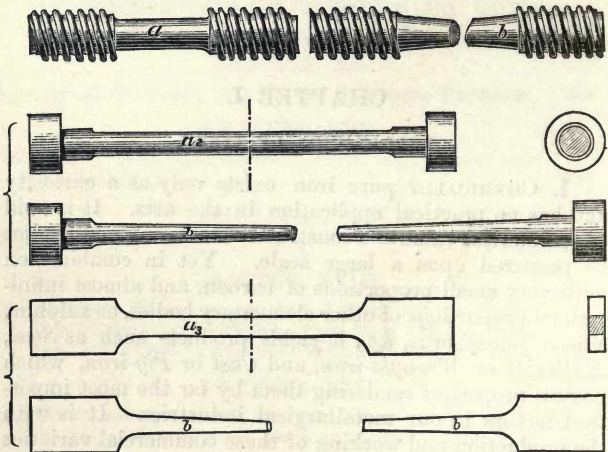

Fig. 1.—Forms of Test-pieces ; *a*, before fracture, and *b*, after fracture.

tively. $\cdot 00635 \times$ number of tons per square inch = number of kilogrammes per square centimetre.

This quality of tenacity is possessed by wrought or malleable iron and by steel in a very marked degree, the latter standing at the head of the metals in this respect ; but, as will be mentioned subsequently, this quality is much affected, in steel especially, by its composition, by its freedom from certain deleterious elements and foreign matters, and also by the molecular condition arising either from the mode of its preparation or from its previous treatment, physical or mechanical, as by hammering, rolling, annealing, hardening in water or oil, &c., &c.

Figs. 1 and 3 indicate the more general forms of test pieces employed in testing the tenacity of bars, plates, &c., of wrought iron or steel, together with their usual mode of fracture; and Fig. 2 shows the grip for holding the test-piece in the machine. The length of the test-pieces and the area of their cross section vary in different works. Thus in testing bars, while some firms operate upon samples of only two inches in length between the points of measurement, and with half an inch of sectional area ($\cdot 79$ inch diameter), as in Fig. 1, *a*, others—and their practice is the more general—operate upon pieces of six, eight, or ten inches in length. The shorter lengths are employed in engineering establishments,

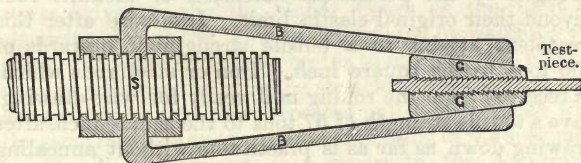

Fig. 2.—One Form of the Bridle and Grip for holding the Test-pieces in the Testing Machine. (p.352).

for the testing of forgings, or finished work, whilst the larger specimens are always employed by the manufacturer in testing rolled bars or plates.

3. **Ductility** is the property of being permanently extended by a tensile force, or of being drawn into wire. Like tenacity, it is powerfully influenced by the composition of the iron or steel, and is markedly affected by each one-tenth per cent. of carbon that enters into the composition of the metal, whilst silicon in very much smaller proportions likewise sensibly affects it. Experiments conducted at Woolwich indicate that this quality varies also with the temperature; thus wrought-iron, such as Yorkshire rods, $\cdot 70$ inch in diameter, which possessed at 100° Fahr. a ductility represented by 25, showed a ductility of only 15 at a temperature of 200° Fahr., and of 13.75 at a temperature of 500° Fahr.

4. **Elasticity** is represented by the length to which a given rod, bar, or plate of metal may be extended by a tensile force without remaining permanently lengthened on removal of the stretching force.

5. The **limit of elasticity** is an expression employed to represent the *force* required to extend a given section of metal to the limit of its elastic strength; or is the greatest tensile stress registered before an appreciable permanent set is produced in a given section of the metal. Within certain limits the stretching of either iron or steel beyond its original elastic limit increases the strength and range of its elastic action; *cold-rolling* and *wire-drawing* afford examples of such an increase of strength by the permanent extension of metallic rods beyond their original elastic limit. Iron wire after this treatment attains to a tensile strength of upwards of 100 tons to the square inch. Iron or steel rods which, as received from the rolling mill ready for wire-drawing, have a tensile strength of 57 tons to the square inch, after drawing down as far as is practicable without annealing will have acquired a tensile strength of 80 tons to the inch, and the same wire, when finished to No. 14 gauge ($\cdot 087$ inch diameter), possesses a tensile strength of upwards of 98 tons to the inch.* The wire employed by Sir William Thomson in his deep-sea soundings sustained 149 tons to the inch. Steel, which in bars of the ordinary sizes used for bridge building has a tensile strength of about thirty-two tons to the square inch, with an elongation of 15 per cent. in samples of one foot in length and an elastic limit of about seventeen tons per square inch, will have, after drawing into wire, a tensile strength of seventy-two tons to the square inch, with an elongation of 4 per cent. in samples of one foot in length.† In the same manner the links for Suspension Bridges have been purposely strained slightly beyond the original limit of their elasticity before putting to work,

* "Revue Universelle des Mines," 1881.

† Transactions of the American Society of Civil Engineers, 1880.

whereby bars of somewhat altered dimensions are produced, but which possess also a little more rigidity than the originals. Again, bridge or ship-plates of the same quality will vary as much as two tons to the square inch in their tensile strength, according as the rolling is finished at a high heat or at a very low temperature, the latter yielding the stronger plate, but after annealing both plates will then have the same lower strength.

6. It is understood that to subject a test-piece to repeated tensile stresses, each of which is just insufficient to give a permanent set to the sample, will gradually increase the tensile strength corresponding to the limit of elasticity. In other words, to remove the stress after each pull or elongation of the specimen caused by the stress, gives a slightly higher figure as the limit of elasticity than if the limit be determined by watching the point where the elongation begins to increase in a marked manner without removing the stretching weight after each elongation; so that these repeated pulls are attended with the same result as an increased hammering of the specimen.

Mr. T. F. Barnaby, in a report to the Admiralty, says that Bessemer steel heated to 400° Fahr. is ten tons per square inch stronger than when at the normal temperature, and loses at the same time but one-third of its ductility, and this increase in strength appears to hold up to 600° Fahr. In iron, again, there is an increase, but only to the extent of one-third of the above, and the increase in strength is attended by the loss of from one-quarter to one-half of its ductility. At a very dark-red heat there is a great fall in the tensile strength of both iron and steel.*

7. The high range of the limit of elasticity in steel, compared with the ultimate strength of the metal, together with the greater range of its elastic action, and its superior tensile strength over iron, are the advantages upon which the introduction of steel as a constructive material largely depends.

* *The Engineer*, March 31st, 1882.

8. **Fatigue** is the diminished resistance to fracture which comes after repeated applications of stress, especially after stresses varying within a wide range.

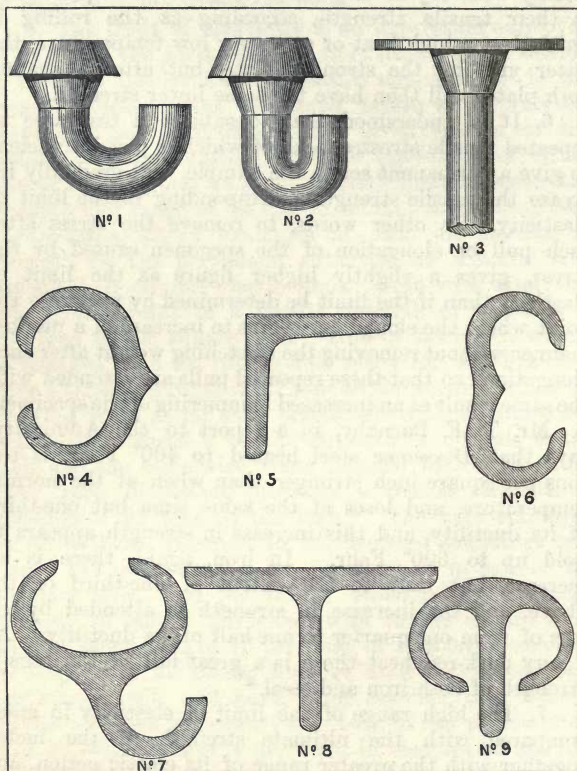

Fig. 3.—Forge Tests of the Malleability and Ductility of Iron and Steel.

9. **Malleability** is the quality of permanently extending in all directions by pressure, as by hammering

or rolling, without rupture, and is essential in the metal to be extended by rolling into thin sheets.

All malleable metals are more or less ductile, whilst iron and steel are amongst the most malleable. Russian sheet-iron has been exhibited at Paris of a thickness not exceeding $\frac{1}{70}$ part of an inch, and Fig. 3 shows a usual test of this quality as applied to steel rivets and angle irons, which are first heated to redness, and then bent or hammered into the forms shown without cracking at the edges.

10. Welding is the quality whereby, if two clean surfaces are presented at a suitable temperature, and pressure applied as by hammering or squeezing by hydraulic or other power, they will unite to form one coherent mass. The conditions necessary for welding are these : 1. that the surfaces shall be perfectly clean. 2. that the iron or steel shall be at a temperature producing a plastic, coherent, and amorphous, non-crystalline (but not fluid) state. Under these conditions but moderate pressure is required to ensure a perfect weld.

This property of welding is typically presented by wrought-iron at a white heat, and in a scarcely inferior degree by the milder qualities of steel, whilst in cast-iron there is an entire absence of it. As above mentioned, it is necessary that the surfaces to be welded be quite clean and free from scale, and for this purpose the smith throws upon the white-hot surface of iron on his hearth a quantity of sand (silica), which forms a readily fusible and fluid slag with the oxide of iron on the welding surface, so that, when the two surfaces are placed in contact and the mass is struck with the hammer, the fluid slag is thrown out, leaving the metallic surfaces in contact, clean and free from oxide or cinder. When steel is the subject of operation, the smith often prefers a mixture of ten parts of borax (Na_2BO_3) with one of sal-ammoniac (NH_4Cl), which powder he uses instead of sand for cleansing the oxide from the surfaces to be welded.

Professor Ledebur concludes that the difficulty in welding some varieties of malleable iron arises from the presence of such foreign bodies as carbon, silicon, sulphur, phosphorus, oxygen, manganese, copper, &c. : and he adds that, up to 0·7 per cent., oxygen in combination is less injurious to welding than a larger proportion of manganese, silicon, or phosphorus, but if oxygen be present beyond 1 per cent., then welding becomes impossible. The above-mentioned elements harden malleable iron, and probably affect its weldability by their ready oxidability. All foreign substances present in the iron, except fluid silicates, which remove the scale and so clean the surfaces to be welded together, have an injurious influence upon the welding quality, hence the purest iron can usually be the more easily welded.

11. The temperatures employed in working iron and steel are often expressed by such terms as "red-heat," "white-heat," &c., and the following figures indicate approximately the temperatures so defined :—

<i>Incipient redness</i>	corresponds to a temperature	525° C. (977° F.).
	of about	
<i>Dull red</i>	"	700° C. (1292° F.).
<i>Cherry red</i>	"	900° C. (1652° F.).
<i>Deep orange</i>	"	1100° C. (2012° C.).
<i>White-heat</i>	"	1300° C. (2372° F.).
<i>Dazzling white</i>	"	{ 1500° C. to 1600° C. (2732° F. to 2912° F.).

12. **Toughness**, in metals, is a relative expression of the power of resisting fracture by bending or torsion, and it is measured by the number of times to which a definite section of the metal can be bent through a certain angle on either side the perpendicular without any fracture.

13. **Softness** is a relative term sometimes used to express the quality of a metal whereby it *easily* permanently yields to pressure without fracture.

14. **Annealing**, in the case of iron and steel, is the name applied to the operation by which the metal is first heated to bright redness, and is then allowed to cool down

slowly, either in the open air, or, more usually, under a layer of ashes or other materials having an inferior conductivity for heat. Annealing is often prescribed as an antidote for correction or prevention of the irregularities in strength arising from unequal or irregular cooling in steel and other castings, or in forgings the several parts of which have been finished under the hammer at different temperatures. By again re-heating such articles to a uniform red-heat, and then allowing them to cool down as slowly as possible, the molecules are enabled to assume a more uniform and normal condition with respect to each other, whereby the probability of any local tension or strain existing at any point is minimised.

Sheet-iron, after rolling, is frequently annealed in quantities of eighteen tons of plates at once, for which purpose the plates are placed in boxes of about ten feet in length, five feet six inches in depth, and three feet six inches in width. The boxes, when charged, are run into furnaces where they remain about twenty-four hours, so as to become regularly and uniformly heated throughout; they are then withdrawn and allowed to cool down during four days without the access of air, after which the sheets come out quite clean and free from scale.

The same term (annealing) is also applied to the operation of slowly heating to redness of crucibles before introducing them into the steel melting furnace, as described on page 420.

15. Cold-short is the term employed to express the condition of iron or steel, in which it cannot be worked by hammering or rolling at or *below a dull red-heat* without more or less fracturing or cracking at the edges, according to the degree of the cold-shortness; though such metal may, under the same conditions, be worked with the utmost facility at a white or welding heat. Red-short, on the other hand, is applied to such metals as do not permit of being readily worked at a temperature at or *above redness*, although such metal frequently admits of being worked

by hammering or rolling without fracture at a low red-heat. Amongst the elements which, in small quantities, induce cold-shortness in iron or steel, may be enumerated *phosphorus*, *silicon*, *arsenic*, and *antimony*, of which the first mentioned is the most common source of this defect ; whilst red-shortness is often the result of the presence of an undue proportion of *sulphur* in the metal, but *copper*, *antimony*, *silver*, *calcium*, &c., also produce the same effect.

16. **Ore** is the name applied to the metalliferous matter in the state in which it is extracted from the mine by the miner, and which in the case of iron is always either an oxide or carbonate of the metal, accompanied by certain extraneous matters, *gangue*, or *vein stuff*, essentially siliceous, calcareous, argillaceous, or bituminous in character, as will be further noticed when speaking of the several ores of iron. In Wales and some other districts the term "mine" is used as synonymous with ore, the same word being thus used to designate both the workings and the metalliferous matter extracted from them.

17. **Reduction, or Smelting**, is the process or processes employed for the separation or extraction on the large scale of a metal from its ores, and the active element used in effecting the reduction is known as the "reducing agent," which, in the case of iron or steel, is invariably carbon or carbonic oxide (CO), aided by a very high temperature.

18. **Calcination** is the process in which iron-ores are heated in heaps, or kilns at a comparatively low temperature, for the expulsion of water, carbonic anhydride (CO₂), sulphur, and other volatile matters, with the oxidation of the ferrous oxide and carbonate to the condition of ferric oxide. The necessary heat is produced either by the combustion of the bituminous matters in the ore itself, as in certain Scotch Blackband Ironstones, or by the addition of fuel which is mixed with the ore to be calcined in the heaps or kilns, or by the waste heat drawn from the blast furnaces.

19. **Fining** is the term employed to designate the stage of the process in the conversion of pig into malleable iron, during which the decarburisation of the pig-iron is mostly effected, either in the puddling and pig-boiling processes, or in the charcoal finery working upon refined metal.

20. **Refining** is the process sometimes employed to effect the partial decarburisation and purification of pig-iron, with its conversion thereby into white, refined, or plate metal, as a preliminary to its conversion into malleable iron by its subsequent treatment either in the puddling furnace or in the charcoal finery.

21. **Puddling** and **Pig-boiling** are processes whereby pig or refined iron is converted into malleable iron either in fixed reverberatory or in revolving furnaces.

22. **Shingling**, or **Nobbling**, is the name applied to the treatment to which the puddled ball is subjected in the squeezer or under the hammer, for the welding together of its particles into a solid bloom, with the expulsion of slag, cinder, and scoriæ from the puddled ball.

23. **Cementation** is the process by which the *carburisation* of malleable iron for the production of steel is effected, by the prolonged exposure of it at a temperature below fusion, to the action of solid or gaseous carbonaceous matters. The same term is also applied to the converse class of operation, by which articles made of cast-iron are rendered malleable by a process of *decarburisation*, effected by exposing them to the prolonged influence of heat and oxidising materials, as hæmatite, iron-ore, etc.

24. A **Flux** is a substance added to the furnace charge, which, by combining with the siliceous and extraneous matters or gangue of the ore, yields at the furnace temperature a readily fusible substance known as a *slag*. In the case of iron ores accompanied by a gangue of infusible quartz, the ore might still be smelted without the addition of any flux, but it would only be at the expense of a loss

of iron ; since ferrous oxide (FeO) readily combines with quartz or silica, producing a fusible ferrous silicate, which is not reducible by carbon or carbonic oxide, the reducing agents of the blast furnace, and which therefore would pass away into the slag with a corresponding loss of iron. A similar result follows if the gangue be argillaceous, for the aluminous silicate (clay), which alone is practically infusible, combines readily with a portion of the ferrous oxide of the ore, producing thereby a double silicate of alumina and iron, which is easily fusible ; but to obviate the loss of iron which would thus result it is usual to add a flux of limestone, which enters into combination with the silica or siliceous clay, yielding thereby fusible silicates, or slags of the double silicates of lime and alumina. In the hæmatite districts, where the ores are the rich oxides of iron (hæmatites), it becomes necessary to add as the fluxing materials not only lime but also argillaceous matters, in the form of shales or argillaceous iron-ore. The conditions regulating the quality and amount of materials added as fluxes will be more fully discussed when treating of the blast-furnace reactions.

25. Slags are the readily fusible compounds, resulting, as above noted, from the combination in the furnace of the siliceous and other matters of the ore with one another, and with the materials added as fluxes, the resulting slags in virtue of their lower specific gravity floating above the molten metal in the furnace hearth.

Slags from the Blast-furnace, Bessemer Converter, Siemens Hearth, or other iron- or steel-producing furnaces or apparatus, are thus *anhydrous silicates of lime, magnesia, alumina, iron, and manganese*, with smaller proportions of other metallic bases derived, as just noted, from the extraneous matters of the ore, the ashes of the fuel, the flux added to the furnace charge, and, in a certain degree, from the materials of which the furnace is constructed. The slags are possessed of the most various physical, chemical, and mechanical properties, depending upon a variety of

causes, such as a *light or heavy burden*, the former usually yielding light-coloured, white, or grey slags, whilst the latter has a tendency to yield slags containing iron and which are thus either black or dark in colour. An *excess of lime* generally produces a very friable slag of a dull stony aspect; but whilst a blast-furnace slag will be dull and opaque if cooled slowly, a similar slag will be lustrous and glassy if cooled quickly. Blocks of slag from the blast-furnace frequently present layers of grey, brown, blue, reddish-black, and white in the same block; further, as a rule, the slower the rate at which the slag has cooled, the greater is the tendency to assume a crystalline structure; also, if the slag be not a definite chemical compound but a portion crystallised out during cooling, leaving the residue as an amorphous mass, it is found that the crystallised portion has often a definite chemical composition, whilst the amorphous portion cannot be formulated. Again, a slag which usually cools so as to form a highly-coloured vitreous body, will often swell up into a white pumice-like body if allowed to flow in contact with water when it is tapped from the furnace; and, in the same manner, hair-like masses or aggregations of fine shreds are produced by the mechanical action of the blast meeting the pasty descending slag in the furnace. Ferrous oxide increases the fusibility of the slag, whilst magnesia decreases it, and thus a dolomitic (magnesian) limestone added to the blast-furnace as a flux decreases the fusibility of the slag, and has a tendency to whiten the pig-iron.

Small quantities of the metallic silicates suffice to impart their distinctive tints to the slags in which they occur; thus the dark green or greenish-black colour so frequently observed in the slags produced in the iron manufacture is due to the presence of a ferrous sulphide; whilst the blue colour often seen in iron slags is by some attributed to the presence of Titanic oxide, and by others to ferrous oxide; and the anethyst-blue colour of certain charcoal furnace slags appears to be due to the

presence of manganese. Ferrous oxide when present also materially lowers the melting-point of the slag.

26. *Blast-furnace slags* are regarded essentially as combinations of monobasic and sesquibasic silicates of lime and alumina respectively, in the proportions represented by the following formula—

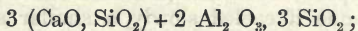

whilst Dr. Percy considers the slag or cinder of the refining furnace (tap or forge cinder) to be an orthosilicate of the formula—

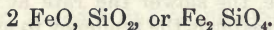

CHAPTER II.

REFRACTORY MATERIALS, CRUCIBLES, ETC.

27. THE refractory materials used in the metallurgical treatment of iron and steel are usually fire-clays (impure hydrated silicates of alumina) and a few natural rocks or minerals, either alone or suitably mixed with other ingredients, as *lime, graphite or plumbago, burnt-clay, &c.* The materials so prepared are then moulded into bricks or crucibles of various forms, into pipes, tiles, tubes, &c., as may be required, or are rammed in position upon furnace hearths, so as to form bottoms or linings in the different ways to be subsequently noticed.

28. **Rocks** can rarely be used alone, owing to their want of homogeneity, their great tendency to crack when exposed to high temperatures, and their want of cohesion after being once broken up prior to their being moulded into the special shapes required in furnace construction.

29. **Clays** also can rarely be used singly or in their raw state, but require admixture with other ingredients, as well as some preliminary mechanical treatment, to adapt them to the requirements of practice, since raw untem-

pered clays when used alone invariably contract in volume, and crack when exposed to a high temperature, leaving thereby fissures and depressions which quickly destroy the furnace in which they occur. Clays are refractory in proportion to their basic character—that is, to the alumina (Al_2O_3) which they contain—and are less useful as fireclays, as they become acid (siliceous) in their character; whilst the presence of ferrous oxide (FeO) to the extent of 2 or 3 per cent. renders most fire-bricks useless at the temperature of the Siemens Steel-Melting Furnace. The *plasticity of clays*, or their capacity to be moulded into any required form without loss of cohesion, is due to the chemically combined water which they contain, and depends to some extent upon the amount of alumina which enters into their composition, and upon the degree of fineness of the structure of the clay; the finer the particles usually the more plastic is the clay. The *hygroscopic water* of clays may be expelled by heating them to 100° C. (212° Fahr.), without thereby impairing their plastic quality; but at a higher temperature the combined water is also expelled, and the clay then loses all plasticity, which quality it does not recover, even when again mixed with water, although the water so added is soaked up rapidly. *Alkalies*, when present to the extent of from 1 to 2 per cent., render fire-clays or fire-bricks fusible at high temperatures. Lime and magnesia (both by themselves very refractory materials) suffice, when in but small portions, to make most fire-clays comparatively fusible.

30. Lime (CaO) and Magnesia (MgO) are very refractory, and are both used in the manufacture of certain crucibles employed in metallurgical operations, but it militates against the use of magnesia that it is somewhat expensive and difficult to obtain, although large quantities of an impure magnesian limestone have latterly been found in the island of Eubœa. *Lime* always occurs native in the form of calcic carbonate, which, upon the application of heat, loses its carbonic anhydride (CO_2) and becomes caustic, but on the withdrawal of

the heat, and fresh exposure to atmospheric influences, it rapidly re-absorbs carbonic anhydride and moisture, partially slacks, and falls to powder; hence it can only be used in such furnaces as allow of a continuous, non-intermittent heat, as in certain Styrian furnaces, where it is sometimes employed. Owing to the facility with which lime and silica combine to form a fusible silicate, it is necessary to avoid contact of the two in any part of a furnace exposed to a white heat.

31. **Magnesite**—the impure magnesia occurring at Eubœa and elsewhere—contains a little lime besides silica, serpentine, and ferrous silicates, which latter require separation by hand either before or after calcination of the mineral. Magnesia is used either in the form of bricks or as crucibles, and, like lime, it first requires calcination at a very strong heat to expel carbonic anhydride, and also to prevent the contraction that would otherwise take place upon heating. The calcined material is then mixed with from 15 to 30 per cent. of the imperfectly calcined or raw mineral, and from 10 to 15 per cent. of water is added, when, after thoroughly mixing, it is then pressed into iron moulds, dried, and burnt as with ordinary bricks.

32. **Bauxite** is a hydrated aluminous ferric oxide of variable composition, containing usually about 60 per cent. of alumina and only from 1 to 3 per cent. of silica, with 20 per cent. of ferric oxide (Fe_2O_3) and from 15 to 20 per cent. of water, but other specimens contain much larger proportions of silica with less ferric oxide. It is a very refractory body, and affords an example of a substance containing some 20 per cent. of oxide of iron, but being yet practically infusible; whilst 4 or 5 per cent. of ferrous oxide in most fire-clays renders them as fusible as ordinary bricks, and 2 per cent. of ferrous oxide in Dinas-brick renders it quite useless in the steel-melting furnace.

33. *Bauxite Bricks* are formed by mixing the calcined bauxite with from 6 to 8 per cent. of some binding material such as clay and plumbago, whereby, upon the application of intense heat, the plumbago partially reduces the iron of

the bauxite, and the brick so produced becomes practically infusible. Where such bricks can be applied, they are much more durable than the best fire-bricks; they resist the most intense heat, as also the action of basic slags; after heating for some time they become intensely hard, and then also resist strongly the mechanical action of wear or abrasion.

34. Fire-clays are such as will withstand exposure to a high temperature without melting or sensibly softening. As already noted, they are essentially hydrated aluminous silicates, with more or less lime and magnesia in the form of carbonates, iron as pyrites (FeS_2), free silica (SiO_2), smaller quantities of potash (K_2O) and soda (Na_2O), with water in both the combined and hygroscopic form, as is shown by the following

AVERAGE ANALYSES OF VARIOUS WELL-KNOWN FIRE-CLAYS.

	Stour- bridge Clay.	South Wales Clay.	Con- tinen- tal Clay used for Fire- bricks.	Dinas Clay.
Silica	63·30	67·12	66·10	96·73
Alumina	23·30	21·18	19·80	1·39
Potash	—	2·02	—	} .20
Soda	—	—	—	
Lime	·73	·32	—	·19
Magnesia	—	·84	—	—
Ferrous Oxide (FeO)	1·80	—	—	·48
Ferric Oxide (Fe_2O_3)	—	1·85	6·30	—
Water Combined	—	4·82	—	} ·50
„ Hygroscopic	10·30	1·39	7·50	
Organic Matter	—	·90	—	—
	99·43	100·44	99·70	99·49

The value of a fire-clay largely depends upon its freedom from such bodies as calcic carbonate (CaCO_3), iron pyrites (FeS_2), and ferrous oxide (FeO), any of which at high temperatures would readily combine with the free

silica (SiO_2) of the clay, with the formation of readily fusible vitreous silicates. The presence of 3 or 4 per cent. of foreign oxides in a siliceous clay—that is, such as contains much free silica—will render it fusible; but if the clay be aluminous, then, owing to the infusibility of most aluminates, even 6 or 7 per cent. of ferrous oxide does not destroy its refractory quality; hence, wherever a scouring basic slag has to be encountered, an aluminous clay as free as possible from silica is desirable. The presence of alkalis in sensible amount—as 1 per cent. or upwards—materially impairs the refractory character of the clay. Oxide of iron also has a strong fluxing effect, and 2 per cent. or upwards affects the fusibility of the clay, although if alkalis be absent, then 3 per cent. of ferrous oxide does not very seriously affect fire-bricks, except at the very highest temperatures.

35. Fire-clays occur most largely in the Coal Measures of the carboniferous strata; also, though less frequently, in various other geological formations. Clays obtained from the same locality and apparently of the same kind are found to differ widely in their degree of fusibility, arising from variations in the proportions of the free and combined silica, from the influence of free silica as explained in the preceding paragraph, and also from the substitution of small quantities of one metallic oxide for another; thus a clay containing magnesia (MgO) is rendered more fusible if a little lime (CaO) be substituted for a certain proportion of the magnesia. Further, the power to resist heat is influenced by the molecular condition of the particles of the clay in a manner but imperfectly understood, as also by the presence of organic matter, and by the mechanical arrangements of its particles—generally the coarser the particles the more refractory will be the material.

36. Fire-bricks should withstand 1° continued exposure to the highest temperatures of a furnace without decomposition, cracking, fusing, or sensibly softening; 2° they should bear considerable pressure whilst heated without suffering fracture or distortion; 3° they should be unaffected

by considerable, and sometimes sudden, variations of temperature; 4° for certain applications they require to be unaffected by contact at a white heat with such metallic oxides as those of iron and magnesia, or other basic slags or scoriæ; 5° contact with heated fuel should be without effect upon them; 6° they should be able to resist at one time an oxidising, and at another a reducing, action; 7° for commercial considerations, fire-bricks are required to be regular in shape and uniform in quality. Bricks combining all these qualities are rarely to be met with; thus the Dinas and other silica bricks to be subsequently described, whilst serving admirably for the construction of reverberatory furnace-roofs, where the bricks do not come into contact with metallic oxides or scoriæ, would be quite worthless (owing to the large proportion of free silica entering into their composition) in the bottom of a furnace upon which iron or steel was to lie molten for any lengthened period.

37. In the manufacture of fire-bricks, their constituent fire-clays cannot be used directly as they are found—that is, in the raw state—since, although the clay may be sufficiently refractory for the purpose intended, yet when subjected to rapid alternations or changes of temperature, or even in the drying of the bricks after being moulded, they are found to split or crack. To obviate this difficulty without also impairing the refractory nature of the clay, the raw clay is first tempered or exposed for some time to the action of the atmosphere before moulding into bricks, and other materials also—such as previously *burnt* fire-clay, old bricks, graphite in powder, small coke, crushed quartz, or siliceous sand (as may be required for the particular purpose to which the bricks are to be applied),—are also mixed with the clay. Where resistance to extreme heat only is required, then an excess of silica is preferable in the clay, but if scouring basic slags are also to be encountered, then graphite, coke, or materials of that class, are added.

38. For brick-making, the fire-clay, as just noted, is

first exposed under sheds to the atmosphere, but protected from the weather, and is then, either alone or in admixture with such substances as above named, ground between rolls or under edge stones to a fine powder, which is then mixed with water and thoroughly incorporated in a pug-mill; after which the mixture is moulded into bricks by machine or hand labour, as in the case of ordinary bricks. The bricks are then laid out to dry, and, when sufficiently dry and resisting are placed in kilns, each holding from 15,000 to 20,000, arranged so as to allow of the heated gases from the combustion of the fuel burning on a grate at the end of the kiln to circulate around and between them; the bricks after some six days' exposure in this manner are then sufficiently burnt and ready for withdrawal, for which purpose the fires are withdrawn, and the kilns allowed to cool down. The shrinkage during the drying and burning of fire-bricks is considerable, so that for the production of a 9-inch brick the raw clay brick will require to be from half-an-inch to three-quarters of an inch longer than the burnt brick; the exact amount requiring determination for each mixture of clay, since the amount of contraction varies for almost every clay or mixture of clays.

39. Fire-bricks must be set in fire-clay and never in lime mortar, otherwise at furnace temperatures the free silica of the clay or brick would combine with the lime of the mortar, to the production of a readily fusible silicate of lime, and the consequent destruction of the furnace.

40. **Dinas Brick** is a highly refractory brick, made from a fire-clay occurring in the Vale of Neath which contains 97 per cent. of silica, with about $1\frac{1}{2}$ per cent. of lime, and smaller proportions of alumina, ferrous oxide, alkalis, and water. The brick presents on fracture a yellow matrix, embedding fragments of quartz, giving the fracture a rough, hackly appearance. These bricks are employed in the roofs of reverberatory and heating furnaces, where they will withstand a clear white heat, but, as already mentioned, they become perfectly useless whenever they come into contact with oxide of iron.

41. **Silica Bricks**, as the name implies, are composed largely of silica, the rock or stone from which they are made by the Landore Siemens Steel Company being the Dinas Rock of the Swansea Valley, yielding 98 per cent. of silica, the remaining 2 per cent. being chiefly alkaline matter. For their manufacture the stone is first broken up into a suitable size for crushing under rolls weighing some three tons each, and during the crushing under the rolls lime cream (a thin paste of lime and water) is also added to the pan for incorporation with the ground silica; and in this manner about half-a-hundredweight of lime is added to each ton of silica stone. The mixture so obtained is pressed into moulds somewhat smaller than the burnt bricks are required to be, the bricks being usually hand-made to the various shapes and sizes needed in furnace construction. The bricks, which are now very tender, are carefully placed for drying upon a floor heated by steam, when, after thirty-six hours' exposure, they are stacked in bee-hive ovens or kilns, each holding about 35,000 bricks, and are there heated or burnt during about five days, from whence, after the cooling down of the kiln, which occupies another five or six days, the kilns are opened and the bricks withdrawn. The bricks are still tender or brittle in comparison with ordinary bricks, and require considerable care in transport, and need to be kept from any lengthened exposure to rain or wet. They are of a light yellowish-brown colour, with a coarse, irregular, granular fracture, and are highly refractory; they are used most extensively for the roofs, ports, and other parts of the Siemens Open Hearth steel-melting furnace, where the most intense heat occurs. For these purposes the bricks made by the afore-mentioned company are not only supplied to the various English steel works, but are exported largely to America, and elsewhere. Silica bricks expand in burning, so that a brick about eight and three-quarter inches long before burning comes out nine inches long after burning, whilst a considerable further expansion occurs

when the bricks are heated to high temperatures, followed by a corresponding contraction on again cooling; and hence it becomes necessary on first heating furnaces where these bricks are used, to loosen the tie-rods, and to tighten them up again as the furnace cools; or the same purpose is effected by affixing powerful springs between the buck-staves of the furnace and the nuts on the tie-rods, to compensate and allow for the expansion and contraction of the roof during its working. If the furnace castings and tie-rods are sufficiently strong to resist the pressure produced by the expansion of the bricks, then the roof itself rises and falls in the crown as it is heated and cooled. These bricks cannot be set in a lime mortar, but are set with the smallest possible quantity of a paste of silica sand, or of silica cement and water. Silica bricks, as already explained, are invaluable for resisting the high temperature in the roof of the Siemens furnace, but for the hearths of furnaces, cupola linings, &c., exposed to the contact of metallic oxides, an aluminous brick is preferable.

ANALYSES OF FIRE-BRICKS, SILICA-BRICKS, GANISTER. *

	Glenboig Fire- brick.	Newcastle Fire- brick.	Silica Brick, Dowlais.	Sheffield Ganister.
Silica	62·10	58·00	97·5	89·04
Alumina	33·10	36·50	1·4	5·44
Ferric Oxide	3·00	1·67	0·55	2·65
Lime	0·90	0·50	0·15	0·31
Magnesia	trace	0·90	0·10	0·17
Potash	0·90	2·12	—	—
Soda	—	0·30	—	—
Loss in Calcination	—	—	—	2·30
	100·00	99·99	99·70	99·91

* Proceedings of the Iron and Steel Institute. Snelus: Refractory Materials.

42. Siliceous Sand is an exceedingly refractory material, containing in some varieties as much as 97 per cent. of silica, the remainder consisting of a little lime, alumina, oxides of iron and water. This sand is used for mixing with fire-clays, &c., in the manufacture of fire-bricks, also as the principal ingredient in the mortar used in the setting of silica bricks; it is also employed in making the bottom or hearth of the Siemens Melting Furnace. Sands less pure than the above are also employed for making the pig-beds of blast furnaces, and by the moulder in making his moulds for castings in cast-iron. Though highly refractory, yet, owing to the absence of all binding qualities, sands are not available for most of the applications to which fire-bricks are applied.

43. Firestones, sandstones, granites, millstone-grit, serpentines, steatites, conglomerate, and other siliceous or quartzose rocks, are sometimes highly refractory, and will stand considerable changes of temperature without cracking; hence such rocks are frequently employed for the hearth-stones of blast furnaces, the boxes of the cementation furnace (*see* p. 407), and also in the construction of reverberatory furnaces. But amongst the causes which limit the use of the rocks in furnace construction are the want of homogeneity in the rocks, the frequent presence of notable quantities of lime, oxide of iron, iron pyrites, &c.,—which decrease the infusibility of the stone—and also the stratification in the sandstones, which necessitates special care that the stones be bedded in the planes of stratification, to prevent exfoliation on the application of heat.

44. Ganister is a siliceous rock in which the silica is cemented together by argillaceous matter, and, without any admixture, the rock has usually sufficient cohesion to hold together after being simply rammed around a wooden model of the interior of the furnace, in the manner described when speaking of the crucible steel-melting furnace, and of the ordinary Bessemer

Converter. The ganisters used for these purposes, also, whilst binding fairly well together, do not shrink much on heating.

45. Crucibles are open-mouthed vessels, which are capable of being moved to and from the furnace by means of tongs, and in which steel or other metals may be exposed to the high temperatures required for their fusion. It is necessary that crucibles should possess in the highest degree all the qualities required of good fire-bricks, such as the power to resist a continued exposure to the high temperature of the steel-melting furnace without softening, or becoming tender, or suffering any distortion of shape; they should not crack or split by sudden alternations of temperature; they should not be affected, save in the slightest possible degree, by contact with incandescent fuel, as coal or coke, or by the slag and ashes produced on their combustion. They should, further, be capable of withstanding the corrosive action of the manganous oxide (MnO) resulting from the oxidation of the manganese in the spiegeleisen or ferromanganese, added to the crucible charge in the production of crucible, or, as it is commonly called, *cast-steel*; and moreover, the crucibles should be sufficiently strong to support the weight of the molten metal when lifted by tongs from the furnace. Crucibles usually the better resist the corrosive action of slags, according as they are more regular in texture, and according to the fineness to which the constituents have been ground, but under these same conditions the tendency to crack is increased.

46. The smaller crucibles known, according to their shape, as *Cornish*, *London*, *Hessian*, and *French* respectively, are made from certain mixtures of fire-clay and sand suitably prepared, then moulded to shape, dried, and kiln-burnt; but they are only used for laboratory experiments by assayers and chemists. A *brasqued* crucible is one of the above-named in which a lining or *brasque* of carbonaceous matter has been introduced; * the brasque of the larger-

* See the author's "Manual of Metallurgy," Vol. I.

sized crucibles is formed of anthracite powder, powdered gas-carbon, and gas-tar.

47. The crucibles employed by the steel melter are of the form and proportions shown at *s*, Fig. 4. They measure from 16 to 19 inches in height, are about 9 inches in diameter at the widest part, and from 6 or 8 inches in diameter at the mouth; they are capable of holding charges of about 75 pounds of bar-

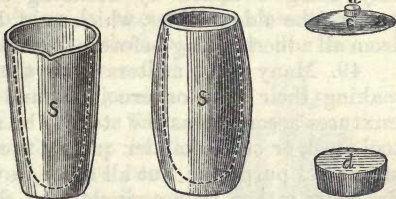

Fig. 4.—Steel-melting Crucibles, Cover and Stand.

iron or blister-steel, previously sheared into small pieces, and which when melted occupy a little more than one-half of the capacity of the crucible. These crucibles when in use are placed upon a conical foot or stand (Fig. 4, *d*) for raising the pot above the furnace bars, and also to enable the hole in the bottom of hand-made crucibles to be stopped with sand* before metal is charged into them. After the charge has been introduced into the crucible the mouth is covered by a loose lid, *c*; this and the stand *d* being made also of fire-clay, but of a somewhat cheaper variety than the pots themselves. It is the practice on the Continent, where machine-made pots with solid bottoms are employed, to provide the lid *c* with a loose stopper, *a*. The charge is introduced into these latter crucibles before they are inserted into the melting-hole or furnace, in which case the lid is placed in position, and luted on after the charge has been introduced, and then it is only necessary to remove the stopper, *a*, instead of the whole lid, for the inspection of the contents of the crucible during the melting process.

48. Steel-melting crucibles or pots, as they are called, require a judicious and careful selection of the fire-clays

* See p. 420

employed in their manufacture, the ingredients also needing to be mixed only in their best proportions. The materials usually employed are fire-clay, both burnt and raw, with graphite and powdered coke; the burnt clay being obtained by breaking up and grinding to powder the old crucibles, which must, however, be cleared from all adhering slag before being used for this purpose.

49. Many steel melters have their own mixture for making their pots or crucibles, and also use different mixtures according as the steel to be melted is hard like tool steel, or of the milder quality such as is required for structural purposes; but all agree in using a mixture of fire-clays rather than a single clay, however celebrated its refractory quality may be; whilst the addition of coke-dust and burnt clay lessens the tendency of the fire-clay to contract in heating, but a sufficient amount of raw clay is requisite to afford the plasticity necessary for moulding. A usual crucible mixture employed in Sheffield consists of Stourbridge clay, Blue clay, China clay (Kaolin), burnt clay in the form of old crucibles broken up and freed from adhering slag, together with plumbago, and coke-dust; or, if for melting specially hard steel, the plumbago is frequently either omitted or introduced in much smaller quantity. The proportions employed by Mushet in his crucibles for melting steel were: 5 parts of Stourbridge fire-clay, 5 parts China clay or Kaolin, 1 part of old pot, and $1\frac{1}{2}$ part of coke dust. Crucibles made from such mixtures as the above are tough when hot, and many may be hammered flat without breaking when at the temperature of the steel-melting furnace.

50. Uniformity in fineness of the materials is ensured by first grinding the dry ingredients to an almost impalpable powder, after which the clays are carefully weighed and thoroughly mixed in the required proportions, either upon the floor, or, as is now more general, in a suitable mill. If the mixture be made upon the floor, water is thrown over the clays, and the whole is thoroughly kneaded together by men trampling or treading with

their bare feet in a systematic manner over the mass during several hours, the clay being periodically cut up and turned over with the spade during the process; and it is still usually considered that better results are obtained by treading the mixture than by mixing in the mill. After thorough incorporation by either method, the clay is then cut up and weighed into portions called *balls*, each sufficient for the production of one crucible (pot); these balls are further worked by hand upon a table or bench before being introduced into the well-oiled and smooth cast-iron mould, or flask, *b* (Fig. 5), of the external shape of the crucible; the plug, *a*, is either a hollow casting or a solid plug of lignum vitæ, with a pin at its lower end of about five inches in length, which passes through a corresponding hole in the loose bottom plate, *f*,

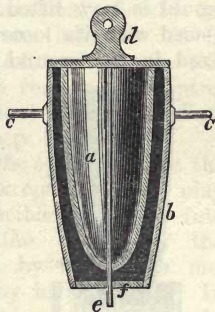

Fig. 5. — Flask and Plug for crucible-making.

of the flask and so serves to centre the plug in the mould; the plug is also made as smooth as possible, and is well oiled before each insertion into the clay in the flask, *b*.

51. In the *manufacture of crucibles by hand*, the ball of clay, thoroughly worked, accurately weighed, and prepared in the manner just described for the preparation of a crucible, is then thrown into the flask, *b*, and the plug, *a*, is forced into the mass of clay by alternately lifting it up and pressing it down again, the concluding pressure being obtained by striking the plug two or three smart blows with a large wooden mallet. In this manner the clay rises all around the plug, filling up accurately the space between the inner surface of the mould or flask and the body of the plug. Finally, by a dexterous twisting movement of the plug, which is at the same time lifted upwards by a pin passing through its eye-stud, *d*,

it is withdrawn, leaving the clay in the form of the crucible inside the flask. The small surplus clay which rose above the mould as the plug was forced down is then cut away by passing the knife around the top edge of the mould, at the same time slightly inclining it towards the centre as it passes around the circumference; thus a clean upper edge is left, and the mould is now lifted by the trunnions, *c c*, and carefully placed with its loose bottom plate upon a small post fixed in the ground (Fig. 6 *k*), when by allowing the flask to fall the crucible remains in the position shown in Fig. 6. A mould of tin-plate of the form of the frustrum of a cone is then placed around the mouth of the mould, pressing it inwards to the form shown in Fig. 4, and the crucible is then removed by carefully lifting it with the aid of a pair of sheet-iron plates fitting around the sides of the crucible. The crucibles are then placed by the workman upon the shelves in the pot-house, where they are allowed to dry slowly for from twenty-four to forty-eight hours, before they are removed to the shelves around the steel-house against the furnace flues (*see* Fig. 84, p.418), and where the crucibles remain for a further period

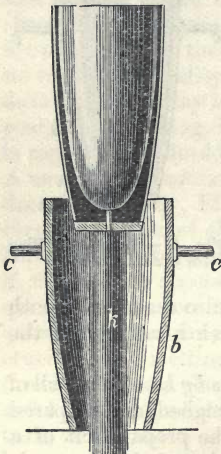

Fig. 6.—Form of Crucible on Withdrawal from the Flask.

of at least ten days or a fortnight before they are sufficiently dry and seasoned to allow of their being safely used for the purpose of steel melting.

It is, however, considered desirable, wherever possible, that the crucibles should remain for five or six weeks in the stoves, or on the shelves of the steel-house before being used, the slower drying being favourable to the longer duration and the production of a more refractory crucible.

52. The operations last described vary somewhat in different establishments; thus, instead of drying the crucibles upon the shelves of the steel-house, in some of the larger works, especially upon the Continent, the crucibles are removed from the pot-house and arranged upon suitable shelves in a series of chambers, where they remain about a fortnight, heated air being in the meantime propelled by a fan through the chambers, whereby the temperature is gradually raised to between 75° C. and 85° C. (167° F. to 185° F.). After drying in this manner, the crucibles may then be removed and introduced direct into the furnace without the intermediate process of annealing as described on p. 427.

53. In *machine-made crucibles* the operations are the same as those above described, except that the plug for forming the inside of the crucible is driven into the ball of clay thrown into the bottom of the mould or flask, and withdrawn by a suitable mechanical arrangement instead of by hand labour. In machine-made crucibles the centre pin, *e* (Fig. 5), in the plug, which serves as the guide to centre the plug when first introduced by hand into the mould, and which leaves a hole through the bottom of the hand-made crucible, is unnecessary in a machine in which flask and plug are fixed quite vertical and concentric; hence machine-made pots or crucibles do not have this hole through the centre of the bottom.

54. In the so-called **plumbago crucibles** the fire-clays are only added in sufficient quantity to give the cohesion and plasticity to the plumbago necessary to enable it to be moulded into the required shapes. Plumbago crucibles are usually much thicker than the ordinary Stourbridge clay pots, their surface is also smoother, and particles of metal do not therefore so readily cling or fix themselves to the sides of the pot. Thus for the purposes of melting alloys, such as brass, special mixtures of cast-iron, and the like, they are much superior to the ordinary clay crucibles; but for steel-melting purposes,

considering their very much greater cost, their advantage is not so decided, although they withstand a higher temperature without softening, and greater alternations of temperature without cracking ; when heated, however, to the temperature of molten steel they are not so tough as the clay crucibles, and are thus considered more dangerous to the puller-out from their greater liability to crush under the pressure of the tongs.

CHAPTER III.

ORES OF IRON.

55. ALTHOUGH iron is an ingredient in greater or less proportion of a vast number of minerals and metallurgical products, yet its **workable ores** do not constitute numerous classes of metalliferous minerals, varying widely in their chemical composition and richness in the metal for which they are to be smelted, like the ores of many of the other metals employed in the arts. But the minerals constituting the workable ores of iron belong to a very limited class, which differ, however, rather considerably in composition and in their richness in metallic iron ; the only minerals worked for the production of iron being such as contain either the *oxides* or *carbonates* of iron, accompanied by a gangue, or foreign matters, usually consisting largely of *calcareous*, *siliceous*, *argillaceous*, or *bituminous* minerals ; and it is upon the nature and quantity of the foreign matter associated with the pure mineral, that the practicability, or otherwise, of profitably working the deposit of ore depends. Thus a hæmatite iron ore, though rich in iron, if associated with any considerable proportion of a mineral phosphate (as calcic phosphate), or with ferrous sulphide (iron pyrites), would be thereby much reduced in value, or probably useless ; whilst 5, 10, or 15 per cent. of manganese in

spathic ores, or of carbonaceous matters in a clay ironstone, would enhance the value of the ore.

56. The *sulphides* and *silicates* of iron occur very abundantly as minerals and metallurgical products, but for reasons to be subsequently explained are not available as ores of iron; and of the *oxides of iron* used in iron-smelting, the most important are the *magnetites*, and the *red* and *brown hæmatites*, whilst the *carbonates* embrace the spathic iron-ores, and the *argillaceous carbonates* known as clay ironstones.

57. The ores of iron also do not permit of the same variety of treatment for the reduction of the metal as is characteristic of many other metals, the only reducing agents practically employed in iron-smelting being carbon and carbonic oxide.

58. Iron-ores occur in almost the whole of the geological series, but most abundantly in the older formations, as the Silurian, Devonian, and Carboniferous strata, although the brown and argillaceous hæmatites also occur rather largely in the Oolites of Europe.

59. Native and meteoric iron, the former constituting the hard fine-grained buttons known as "*native steel*," is sometimes found where coal seams have been ignited in the vicinity of ferruginous deposits; but this and "*meteoric iron*" are of such comparatively rare occurrence, irregular distribution, and small weight, as not to be considered amongst the ores or sources of iron, as employed in the arts.

60. Magnetic iron-ore or "*Magnetite*" is the richest and one of the most widely distributed of the ores of iron. The pure mineral is iron-black or iron-grey in colour, gives a black streak, is brittle, magnetic, and sometimes distinctly polar; it occurs crystallised in the cubic system as octahedra and dodecahedra, but is more generally found in the massive form, yielding a crystalline or granular fracture; and it is also found in the form of grains or sand. The composition of magnetite is represented by the formula Fe_3O_4 , or $\text{Fe}_2\text{O}_3, \text{FeO}$;

when pure it yields 72·41 per cent. of iron, but the ore usually contains only from 80 to 90 per cent. of the magnetic oxide of iron, accompanied with from 5 to 15 per cent. of silica; and it will be noted from the appended analyses that the Swedish magnetites are practically free from sulphur and phosphorus, whilst some contain considerable proportions of manganese.

61. The following are

ANALYSES OF MAGNETIC IRON-ORE.

	Danne- mora ore (Ward).	Oural ore.	Devon- shire (Riley).	Pers- berg.	Bisp- berg (Aker- man).	British Colum- bia.
Ferric oxide (Fe_2O_3)	27·50	68·98	13·00	72·17	68·8	67·31
Ferrous oxide (FeO)	56·80	—	66·50	2·20	21·7	28·33
Manganous oxide (MnO)	0·24	0·37	0·56	·27	0·16	trace
Alumina (Al_2O_3)	—	3·81	3·60	·35	—	—
Lime (CaO)	1·80	1·21	0·56	3·42	—	—
Magnesia (MgO)	·80	—	1·52	8·53	—	—
Silica (SiO_2)	13·20	24·76	—	10·51	—	—
Phosphoric anhy- dride (P_2O_5)	—	0·03	0·57	·024	P·008	0·07
Ferrous sulphide (FeS_2)	—	—	0·04	·029	—	0·09
Water (OH_2)	—	—	3·20	1·93	—	TiO_2 ·11
Insoluble residue	—	—	9·40	—	—	3·97
	100·34	99·16	98·95	99·433	—	99·88
Metallic iron	61·16%	—	56·66%	53·97%	63·84%	—

62. Magnetic iron ore occurs in granite, gneiss, clay-slate, hornblende-schist, and occasionally in limestone formations, and it is also often accompanied by red and brown hæmatites. It is from these ores (magnetites) smelted with charcoal that much of the famed Dannemora (Swedish) iron is obtained. The ore employed at Danne-mora yields from 25 to 60 per cent. of metallic iron,

but the average falls below 50 per cent. ; the ore is accompanied by a gangue, containing silica and lime, in sufficient quantities to permit of its being smelted without the addition of any further flux to the furnace charge.

63. This ore is found in considerable abundance in Norway, Sweden, Piedmont, Saxony, Canada, the United States, Mexico, the Ourals, Siberia, the Island of Elba, in the West of England, in Devon, and in Cornwall.

64. **Franklinite** is less magnetic than magnetite, which it otherwise closely resembles ; it occurs in the metamorphic Silurian limestones of New Jersey, United States. In New Jersey it is first treated for the extraction of zinc, and the residues so obtained are afterwards smelted for spiegeleisen. Franklinite is a mixture of *ferric* and *manganic* oxides $(\text{Fe, Mn})_3\text{O}_4$ with *ferrous*, *manganous* and *zincic* oxide $(\text{Fe, Mn, Zn})\text{O}$, of which Rammelsberg gives as the average of several analyses 45·16 per cent. of iron, 9·38 per cent. of manganese, 20·30 per cent. of zinc, with 25·16 per cent. of oxygen.

65. **Red Hæmatite** is the name applied to a most important class of the ores of iron, which consist essentially of anhydrous ferric oxide Fe_2O_3 , and which occur of various shades of colour, from deep red to steel-grey, with a crystalline, fibrous, columnar, botryoidal, or amorphous structure ; they occur further both in the earthy and the compact form, as also soft or hard, &c. From the variety of their physical characters the red hæmatites have received special names ; thus, the crystalline variety as occurring at Elba, Brazil, &c., is known to the mineralogist as *specular-iron*, or *iron-glace*, and possesses a bluish or steel-grey colour ; it crystallises in the rhombohedral system, yielding a red streak, and containing, when pure, 70 per cent. of metallic iron. The scaly, micaceous, or foliated variety, which is used as the basis of a paint for iron work, is known as *micaceous iron-ore* ; and when red hæmatites assume the form of dull, hard, compact masses, often reniform or kidney-shaped, as occurring in Cumberland, they are then

known as *kidney ore*. The soft and more earthy varieties constitute *red ochre*, whilst *puddler's-mine* or *ore* is the soft, unctuous, compact, earthy form employed for the making and repair of the bottoms of puddling furnaces; another form of hæmatite, occurring as small, hard, flattened grains, is recognised as *lenticular clay-iron ore*.

66. The hæmatite iron ores, owing to their freedom from sulphur and phosphorus, and to the large proportion of silicon contained in the pig-iron smelted from them, have been in large and increasing demand since the introduction of the Bessemer process for the manufacture of steel; for until the recent discovery of the "*basic process*" of Bessemer conversion, only such pig-iron was suitable for the process, and it is now estimated that the gross output of the Furness district alone amounts to nearly one million tons of hæmatite ore annually.

67. The following table shows the average composition of these ores:—

ANALYSES OF RED HÆMATITE IRON ORES.

	Barrow- in- Furness (Richards)	Ulver- stone (Dick).	Ulver- stone (Spiller).	Canadian.
Ferric oxide (Fe_2O_3)	94.88	86.50	94.23	85.037
Manganous oxide (MnO)	0.04	0.21	0.23	—
Alumina (Al_2O_3)	0.07	—	0.51	—
Lime (CaO)	0.34	2.77	0.05	—
Magnesia (MgO)	trace	1.46	trace	—
Silica (SiO_2)	4.55	—	—	5.130
Carbonic anhydride (CO_2)	—	2.96	—	—
Phosphoric " (P_2O_5)	0.03	trace	trace	0.032
Sulphuric " (SO_3)	—	0.11	0.09	—
Sulphur (S)	—	—	—	0.075
Pyrites (FeS_2)	0.47	—	0.03	—
Water (OH_2)	—	—	0.56	—
Organic matter	—	—	—	—
Insoluble residue	—	6.55	5.18	—
	—	100.56	100.88	—
Per-centage of iron	66.42%	60.55%	65.98%	59.526

In the North Lonsdale district the ores average from 52 to 54 per cent. of metallic iron, the highest yielding from 60 to 62 per cent., whilst the poorest contain about 40 per cent.

68. The most important deposits of red hæmatite are found in the Cambrian, Silurian, Devonian, and Carboniferous rocks; the deposits of North Lancashire, Cumberland, and Flintshire occurring in veins in the mountain limestones of the Carboniferous series, and although the ore is not magnetic, the veins run more or less north and south. Red hæmatite is often associated with the brown oxides, and the ore is classed as *hard* or *soft*, according as it contains free silica in excess or otherwise. The more important Continental and foreign deposits of these ores occur in Sweden, Norway, South Germany, Canada, and the United States.

69. Brown hæmatite, or brown iron-ore, is when pure a hydrated ferric oxide, represented by the formula $2 \text{Fe}_2 \text{O}_3 \cdot 3 \text{OH}_2$, and would thus yield 59.89 per cent. of metallic iron. It has a dull lustre, and varies from blackish- to yellowish-brown, but it affords an invariable yellowish-brown streak. It occurs in irregular, compact, more or less homogeneous masses, in the Carboniferous limestone and lower Coal Measures of the Forest of Dean, Gloucestershire, and Glamorganshire; whilst a less pure variety, containing more or less mechanically mixed sand, occurs in the Lias, Oolites, and Lower Greensands of Northamptonshire, Lincolnshire, Buckinghamshire, and Oxfordshire; brown hæmatites also form one of the most important of the ores smelted in France and Germany.

70. The Spanish mines of Somorrostro, near Bilbao, yield a brown hæmatite of Cretaceous age, which was probably deposited from hot springs charged with ferrous carbonate, FeCO_3 . This ore in the undried state yields from 50 to 64 per cent. of iron, with about 1 per cent. of manganese, with only a little sulphur or phosphorus; and distributed throughout are blocks of unaltered spathic ore.

71. "*Bog-iron-ore*" is an impure brown hæmatite, smelted in Canada principally for foundry purposes. *Limonite*, again, is another form, as are also the so-called "*Lake ores*," which occur in granular concretionary masses, dredged during the winter months from the bottom of certain shallow lakes of Norway, Sweden, and Finland; whilst the mineral known as "*Göthite*" is also a crystallised and rich variety of the brown hæmatite ores.

72. As previously mentioned, brown hæmatites vary much, both as regards the per-centage of metallic iron which they contain, and also in their freedom from such impurities as phosphorus and sulphur, whilst manganese is almost always present in those ores, and they are accompanied by more or less earthy matter.

73. As types of the several classes may be taken the following

ANALYSES OF BROWN HÆMATITE IRON-ORES.

	Forest of Dean (Dick).	Glamorganshire (E. Riley).	Northamptonshire (Percy).	New South Wales.	Somoroostro (Baker).	Somoroostro
Ferric oxide (Fe_2O_3)	90.05	59.05	56.20	60.72	78.80	80.75
Manganous oxide } (MnO)	0.08	0.09	0.20	—	0.651	8.15
Alumina (Al_2O_3) .	0.14	trace	2.43	11.175	3.50	3.10
Lime (CaO) .	0.06	0.25	0.49		trace	0.82
Magnesia (MgO) .	0.20	0.28	0.17		trace	1.04
Silica (SiO_2) .	0.92	34.40	29.09	12.66	5.55	3.24
Phosphoric anhy- } dride (P_2O_5)	0.09	0.14	0.84	trace	—	trace
Sulphuric anhy- } dride (SO_3)	—	—	—	—	0.068	—
Sulphur .	traces	—	—	0.075	—	trace
Pyrites (FeS_2)	—	0.09	—	—	—	—
Water (combined) .	9.22	6.14	10.90	13.77	11.653	—
„ (hygroscopic)	—	0.24		1.60	—	2.90
Metallic iron .	63.04%	41.34%	39.34%	42.5%	55.16%	56.52%

74. Titaniferous iron ore, or Ilmenite, occurs massive, but is found more generally as a dark-coloured or black sand along the shores of the Bay of Naples, the North-east coast of America, Labrador, New Zealand, &c. In these districts certain ferruginous crystalline rocks suffer disintegration, and the lighter portions are washed away, whilst the heavier titaniferous particles, or grains, constituting the bluish iron sands, accumulate upon the shore in sufficient quantity to be collected, and, after a preliminary mechanical treatment, to be smelted in the American Bloomery Furnace for the production of wrought-iron direct from the ore. The titaniferous sands contain a large proportion of magnetite, besides titaniferous iron-ore, and these are usually accompanied by free silica, with more or less magnesia. Titaniferous iron ore is a most refractory mineral, and, on account of its fine state of division, is difficult to treat in the blast furnace, but it has been used with some success as a lining material for the several forms of revolving puddling and other furnaces.

75. Spathic iron ores, Siderite, Clay ironstones, Blackband, and Cleveland ironstone are the names given to certain classes of the ores of iron, in which the metal occurs as a ferrous carbonate (FeCO_3) of greater or less purity, and from which nearly two-thirds of the total weight of the pig-iron produced in Great Britain are smelted. The purer varieties are described as *spathic ores*, whilst the amorphous argillaceous ores of the Coal Measures are known as *clay ironstones*, and when largely impregnated with carbonaceous or bituminous matter they constitute *blackband ironstone*.

76. *Spathic ore* in its purest form constitutes the crystallised mineral known as *Siderite*, which, when pure, yields 48.27 per cent. of metallic iron. Siderite occurs as a mineral having a pearly lustre, and varying from yellow to brown in colour, but when it occurs in veins exposed to water and atmospheric influences, it is usually found to have suffered decomposition, and to

have become converted into brown hæmatite to a considerable depth from the surface. Spathic ores often contain considerable quantities of manganous oxide, as is the case with the spathic ore of the Brendon Hills, in Somersetshire, which ore has been in recent years extensively transported to Ebbw Vale, South Wales, to be smelted for the production of the manganiferous pig-iron known as *spiegeleisen*. The other more important associates of spathic ores are calcic and magnesian carbonates, with occasionally also quartz, with copper and lead in small proportion. This ore occurs in the Carboniferous rocks of Durham, Cornwall, Devon, and Somersetshire, but more largely on the Continent, as in the mountain masses of Siegen and Musen, in Rhenish Prussia, where it is found in rocks of Devonian age; at Thuringia, in Hungary, it occurs in Permian rocks; whilst extensive deposits also are present in Styria, Westphalia, Lölling, and Carinthia, in Austria, as also in Hanover and in Russia.

77. Clay ironstone is the argillaceous, amorphous, compact, or earthy variety of ferrous carbonate, occurring either in detached nodules, or in layers of nodular concretions, distributed through the shales and clays of the Coal Measures, or in beds of considerable thickness in Liassic rocks. When not discoloured by admixture with carbonaceous matters or by atmospheric decomposition, it ranges in colour from light grey or yellow to brown, but the lighter-coloured varieties rapidly become brown on exposure to the atmosphere; and, like Siderite, it contains besides ferrous carbonate, appreciable quantities of calcic, magnesian, and manganous carbonates, along with clay (aluminous silicate), phosphoric acid, iron pyrites (FeS_2), and occasionally also other minerals, as blende (ZnS) and galena (PbS). The principal localities of its occurrence are the clays and shales of the Coal Measures of North and South Staffordshire, Derbyshire, Yorkshire, Warwickshire, Shropshire, North and South Wales, Denbighshire, and in Scotland.

78. Blackband ironstone is a clay ironstone, containing from 15 to 25 per cent. of bituminous, coaly, or other carbonaceous matter, which gives it almost the appearance of coal; it occurs in beds most largely in Lanarkshire and Linlithgowshire, to a smaller extent in North Staffordshire, and also in South Wales. Owing to the large amount of carbonaceous matter contained in this ore, it can be calcined in heaps without the addition of any further fuel, and the calcined product will yield from 50 to 60 per cent. of metallic iron.

ANALYSES OF SPATHIC AND OTHER IRON-ORES.

	Spathic ore, from Somersetshire (Spiller).	Clay ironstone from Dudley (Dick).	Blackband, Scotland (Colquhoun).	Cleveland Ironstone (Dick).
Ferrous oxide (FeO)	43.84	45.86	40.77	39.92
Ferric oxide (Fe ₂ O ₃)	0.81	0.40	2.72	3.60
Carbonic anhydride (CO ₂)	38.86	31.02	26.41	22.85
Manganous oxide (MnO)	12.64	0.96	—	0.95
Alumina (Al ₂ O ₃)	—	5.86	—	7.86
Lime (CaO)	0.28	1.37	0.90	7.44
Magnesia (MgO)	3.63	1.85	0.72	3.82
Potash (K ₂ O)	—	—	—	0.27
Silica and insoluble residue	0.08	10.68	—	8.76
Clay	—	—	10.10	—
Phosphoric anhydride } (P ₂ O ₅)	—	0.21	—	1.86
Pyrites (FeS ₂)	—	0.10	—	0.11
Water (OH ₂)	0.18	1.08	1.00	2.97
Organic matter	—	0.90	17.38	—
	100.32	100.29	100.00	100.41
Metallic iron	34.67%	35.99%	33.57%	33.62%

79. Cleveland ironstone is a less pure variety of the argillaceous ferrous carbonate, taking its name from the district of Cleveland, in the North Riding of Yorkshire,

where it is most largely found. It varies in colour between dull bluish-yellow and dark blue, becoming in some specimens almost black; but the darker varieties often contain sensible proportions of ferrous silicate. Owing to the large proportion of phosphates contained in the Cleveland ironstone, it was, until the invention of the Thomas-Gilchrist or basic process for the manufacture of Bessemer steel, used solely for the production of foundry and forge qualities of pig-iron; but it is now possible, by means of that process, to largely eliminate the phosphorus from the pig-iron during the Bessemer conversion. This inferior class of ore has been rendered available for the manufacture of pig-iron suitable for conversion into Bessemer steel.

CHAPTER IV.

METALLURGICAL CHEMISTRY OF IRON.

80. PURE metallic iron, as already stated, is a body difficult of preparation, especially in the compact state, except by purely chemical methods only applicable to laboratory operations, and the pure metal cannot therefore be considered as a substance of practical commercial importance; but in combination with variable but small proportions of *carbon*, and other metallic and non-metallic elements, such as sulphur, silicon, phosphorus, manganese, &c., it constitutes the various qualities of pig-iron, steel, and malleable iron.

81. Pure iron is prepared by the electrolysis of ferrous chloride (Fe Cl_2), by the reduction of ferric oxide ($\text{Fe}_2 \text{O}_3$), or of ferrous chloride, by heating either of them to redness in a tube through which a current of hydrogen gas is passed; or in a nearly pure state it can be obtained by the fusion under a layer of glass free from metallic oxides, of

fine iron wire or iron filings, with artificially-prepared magnetic oxide of iron. Iron as prepared by the last method is a metal varying in colour from bluish-grey to silver whiteness according to the state of its aggregation; as reduced from ferric oxide by hydrogen, it forms a grey powder, which is pyrophoric (that is, takes fire spontaneously on exposure to the atmosphere) if the temperature employed in its production has not exceeded dull redness; but it no longer possesses this quality if the temperature employed in its preparation has exceeded this limit. Electro-deposited iron absorbs or *occludes* hydrogen to the extent of from seventeen to twenty times its own volume, and it appears probable, as will be subsequently noted, that the combinations of iron with carbon, such as cast-iron and steel, also possess this quality when the metal is in its fused state. As obtained from ferrous chloride (FeCl_2), the metal yields well-defined cubical crystals, and the metal is always crystalline after fusion, although a fibrous structure is developed by hammering or rolling. Iron is capable of receiving a high polish, it is very tenacious, ductile, and malleable, the last quality being unaffected by heating and subsequent rapid cooling, neither is it hardened by this treatment. Pure iron is one of the best conductors of electricity, but this property is impaired as the iron becomes more and more impure. It can be magnetised to a very high degree, but rapidly loses its magnetism. Pure iron is softer than the commercial varieties of malleable iron, and has a specific gravity of 7.87. Its fusing point does not appear to have been accurately determined, for whilst Pouillet estimates it at from 1500°C . to 1600°C . (2732°Fahr . to 2912°Fahr .), Scheerer gives it as 2100°C . (3812°F .), but the presence of small quantities of carbon in combination with the metal rapidly lowers the fusing point.

82. Iron is unaffected by dry air at ordinary temperatures (except in the pyrophoric or spongy state already described), or in perfectly pure water free from air, oxygen,

or carbonic anhydride; but if exposed to a moist atmosphere, then the oxidation commonly known as *rusting* rapidly proceeds, especially if carbonic anhydride be also present, as is usual, in the atmosphere. The presence of carbonic anhydride appears essential to the oxidation of the iron by moisture, since the metal may be kept bright for almost any length of time in pure lime water, or in a solution of soda. Under the joint influence of moisture, oxygen, and carbonic anhydride, ferrous carbonate is first produced on the surface of the iron, but this, by absorbing a further proportion of water and oxygen, becomes changed to a hydrated ferric oxide, with the liberation of carbonic anhydride, which latter then reacts upon a fresh portion of the iron in the presence of water and oxygen, and a further quantity of ferrous carbonate is produced, and so the cycle continues to be repeated. Further, the hydrated oxide, or rust, is electro-negative with respect to the metallic iron upon which it is formed, and the electrical condition thus resulting still further promotes the affinity of the metal for oxygen; and the corrosion of the iron thus proceeds rapidly, even to the extent of enabling the iron slowly to decompose water with the evolution of hydrogen at ordinary temperatures. Water holding carbonic anhydride in solution, even though free oxygen may be absent, rapidly attacks and oxidises metallic iron. Iron, when heated to redness in contact with air or oxygen, is rapidly oxidised, with the production of a black scaly oxide readily detachable from the surface of the iron. This oxide constitutes, on the large scale, the *hammer scale* or *hammer slag* of the forge. Iron at a red heat decomposes water with the liberation of hydrogen.

83. Hydrochloric acid attacks metallic iron with the formation of ferrous chloride (Fe Cl_2) and the liberation of free hydrogen. Concentrated sulphuric acid (H_2SO_4) also attacks the metal with the liberation of *sulphurous anhydride* (SO_2), whilst ferrous sulphate (Fe SO_4) remains in solution; but if the diluted acid be employed, then

hydrogen is liberated, and ferrous sulphate remains as in solution as before. The action of nitric acid upon iron, at the ordinary temperature, varies with the degree of concentration of the acid. Thus, ordinary nitric acid attacks iron vigorously with the evolution of nitrous fumes in abundance, but if the acid be dilute there is no sensible escape of gas, but ferrous nitrate (Fe_2NO_3) and ammoniac nitrate (NH_4NO_3) occur in solution; thus $(10 \text{ HNO}_3 + 4 \text{ Fe} = 4 (\text{Fe}, 2 \text{ NO}_3) + \text{NH}_4\text{NO}_2 + 3 \text{ H}_2\text{O})$ strong-fuming nitric acid is without action upon the metal, a bright surface of which may be introduced into the cold concentrated acid without inducing any chemical decomposition, in which case the surface of the metal on immersion assumes a dull whitish appearance, and no further action ensues, the metal having assumed what is known as the *passive condition*. The atomic weight of iron is 56, and its chemical symbol is Fe.

84. Oxides of iron.—As noted in section 82, iron is not acted upon by exposure to dry air or oxygen at *ordinary temperatures*, but if exposed to these gases at a temperature approaching to redness, then oxidation rapidly ensues with the production of a *scale* or *slag* known as “hammer scale,” which is not, however, uniform in either composition or in physical characters. The outer layer of scale is found to be strongly magnetic, almost metallic in lustre, brittle, fusible only at the highest temperatures, more highly oxidised, and somewhat redder in colour than the inner layers, which are less lustrous, spongy, tougher, and less magnetic than the outer layers.

85. Magnetic oxide (Fe_3O_4) is, as just noted, the oxide of iron entering most largely into the composition of *hammer-scale* or *hammer-slag*, but this scale contains besides magnetic oxide, a variable excess of ferric oxide (Fe_2O_3), and hence the varying physical qualities of hammer-scale mentioned in the preceding section. Magnetic oxide of iron also results when iron is exposed at a red heat to the action of aqueous vapour; and this oxide

also remains when ferrous carbonate (FeCO_3) is heated to redness in contact with the atmosphere; as also, according to Kuhlman, when a mixture of ferrous sulphate (Fe SO_4) and calcic chloride (Ca Cl_2) is heated in a covered crucible; whilst Ebelmen states that it results as one of the products obtained by exposing ferrous silicate to the action of heat. Magnetic oxide occurs native (p. 31) as a black lustrous mineral known as *magnetite*.

86. **Ferric oxide** (Fe_2O_3) is a very stable and practically fixed oxide of iron, decomposable however at a white heat, with the liberation of oxygen and the production of the magnetic oxide ($3 \text{Fe}_2 \text{O}_3 = 2 \text{Fe}_3 \text{O}_4 + \text{O}$). Ferric oxide is produced when ferrous sulphate is strongly heated, the salt suffering decomposition with the elimination of sulphurous anhydride (SO_2) and sulphuric anhydride (SO_3), whilst a bright red pulverulent powder, forming the "*rouge*" or "*colcothar*" of commerce, is obtained, which has the composition of ferric oxide. Ferric oxide is *decomposed with the reduction of metallic iron by heating it in a current of carbonic oxide (CO), hydrogen, ammonia (NH₃), or cyanogen (CN), or by heating it along with carbon.* Ferric oxide after ignition is only slowly acted upon by either hydrochloric, nitric, or sulphuric acid, but previous to ignition it is readily soluble in these acids with the production of stable ferric salts; if heated with an excess of sulphur, sulphurous anhydride (SO_2) is evolved, and ferrous sulphide (FeS) is obtained.

87. Ferric oxide is prepared in the laboratory by heating ferrous nitrate, oxalate or sulphate, or a mixture of ferrous sulphate and sodic chloride; whilst it occurs in nature in sufficient abundance to be worked as an ore of iron under the forms of hæmatite, iron-glance, specular-iron, micaceous iron, &c., as previously described when speaking of the ores of iron. This oxide is used in the arts for giving the purple and orange-yellow tints required in the manufacture of glass and porcelain.

88. The hydrated ferric oxide ($\text{Fe}_2\text{O}_3 \cdot 3\text{H}_2\text{O}$) is the most stable of the hydrated oxides of iron, and occurs native as brown hæmatite, Limonite, and Göthite. As the freshly-precipitated oxide obtained by adding potash, soda, or ammonia, to a solution of a ferric salt, it is an amorphous, brownish-red body, readily soluble in acids, and even slightly soluble in water containing carbonic anhydride in solution. It has the composition indicated by the above formula, but after remaining precipitated for some time it loses a portion of its water of composition; or by boiling with water during six or seven days, it loses two equivalents of its water of composition, retaining but one equivalent, assuming thereby a more brick-red colour, and becoming only slightly soluble in the mineral acids.

89. *Iron rust* is essentially hydrated ferric oxide, produced on the exposure of metallic iron to the joint action of air and water, but more rapidly if carbonic anhydride be also present in the manner described (p. 42).

90. Ferrous oxide (FeO) constitutes the third oxide of iron of any metallurgical importance, since, in combination with carbonic anhydride, silica, or sulphuric acid, it yields the more important salts of iron, and forms also the base of several of the iron ores. Thus clay-ironstone contains eighty per cent. of ferrous carbonate, and it exists in a still larger proportion in the crystallized ores such as Siderite or spathic iron ore, whilst in combination with silica, constituting it ferrous silicate ($2\text{FeO}, \text{SiO}_2$), it enters largely into the composition of the various slags, cinders, &c., produced in the metallurgical treatment of iron.

91. Ferrous oxide, both in its anhydrous and hydrated forms, is however a very unstable body, rapidly passing to a higher state of oxidation by exposure to the atmosphere. The hydrated oxide or ferrous hydrate is precipitated as a white flocculent precipitate, when potash or soda is added to a solution of a ferrous salt; but the precipitate rapidly changes, however, from white

to green and then to brown, owing to the absorption of oxygen. The anhydrous oxide, according to Debray, may be prepared by passing steam and hydrogen in definite proportions, over heated ferric oxide (Fe_2O_3), when the oxide in question is obtained as a black, amorphous, non-magnetic, and very unstable body.

92. A fourth oxide constituting *ferric anhydride*, which in combination with water is known as *ferric acid* (H_2FeO_4), is not of metallurgical interest, since it has never been obtained in the free state; and its alkaline salts, which result in small proportion when nitre and iron filings, or nitre and ferric oxide, are heated to dull redness in suitable proportions, are very unstable salts, rapidly and spontaneously decomposing with the liberation of oxygen and the separation of ferric oxide.

93. Iron and carbon, by their union in various proportions, modified by the presence of small quantities of silicon, manganese, sulphur, phosphorus, &c., and by the conditions as to combination or mechanical diffusion in which the carbon exists in the iron, practically determine the several grades of pig-iron, steel, and malleable iron. The essential constituents, however, of these commercial modifications of iron, are, as before stated, *iron* and *carbon*. Although iron does not combine with carbon at ordinary temperatures, yet their union when brought into contact at or above a red heat may be readily effected, both directly and indirectly, with the formation of compounds less highly carburised than pig-iron. Thus, by exposing malleable iron for some days to a temperature at or above a red heat, say $1,000^\circ \text{C}$. to $1,200^\circ \text{C}$. ($1,832^\circ \text{Fahr}$. to $2,192^\circ \text{Fahr}$.), to the action of either carbon in powder, or of other carbonaceous materials, in closed vessels, as in the ordinary manufacture of blister or cement steel by the process of cementation (p. 406), it is found that a union of the carbon and iron gradually takes place, the iron bars becoming more highly carburised than the original metal; the carburisation proceeding from the surface towards the middle of the bar, and penetrating farther

into the bar the longer the temperature and contact are maintained.

94. *Case-hardening*, again, is another example of the superficial carburisation of wrought-iron articles, by heating them to redness for a short time, in contact with leather, horn, or other highly carbonaceous, or some cyanogen, compound. Further, at more elevated temperatures, such as those attained in the blast furnace, carbonic oxide (CO), coal gas, volatile hydro-carbons, cyanides, &c., are decomposed by metallic iron, with the carburisation of the latter; and again, the production of cast-steel by the crucible process is an example of the direct union of carbon and malleable iron, at the more elevated temperature required to melt steel.

95. *Cast or pig-iron*, which forms the most highly carburised form of commercial iron, seldom if ever contains more than 4.75 per cent. of carbon; whilst mild steel containing not more than 0.10 per cent. of carbon is now in daily production, and differs from wrought or malleable iron having a similar content of carbon, rather in the mode of its manufacture and superior tenacity than in its chemical composition. Carbon occurs in pig- or cast-iron under two distinct forms, viz., as *dissolved* or *chemically-combined carbon*, and as *mechanically-diffused crystalline graphite*, the latter being distributed with considerable regularity throughout the mass of iron. The quality, as well as the class, of pig-iron, as also its applicability to the various purposes to which it can be put, are greatly influenced both by the total amount of carbon present in the iron, as well as by the relative proportions of the combined to the graphitic carbon. Thus cast-iron containing a large proportion of graphitic carbon, with smaller quantities of carbon in the combined form, is dark grey in colour, breaks with a flaky, crystalline fracture, and is hence known as *grey pig-iron*; but if the proportions are reversed, and the carbon be largely or almost wholly in solution or chemically combined with the iron, then the pig- is much harder than grey pig-iron, is whiter in

colour, and breaks with a coarse granular or crystalline fracture, and such iron is designated as *white-iron*, a special class of which, usually rich in manganese, being known as *spiegeleisen*. The white irons are often also the most highly carburised forms of pig-iron. Between the two extreme limits in the relative proportions of graphitic and combined carbon in cast-iron, the gradations are numerous and almost imperceptible, but are attended with a corresponding gradation in the colour and other physical qualities of the metal; whilst in other specimens the two forms of grey and white iron are distinctly interspersed throughout the same mass, giving the pig- the characteristic dappled appearance peculiar to *mottled iron*; and, as will be noted when speaking of the commercial classification of pig-iron (p. 75), manufacturers are able to classify for the market the produce of the blast furnace, according to its physical qualities, under eight different heads or numbers, from the softest grey to the hardest white iron, each of the numbers being especially suitable for particular applications in the forge or foundry.

96. Mr. G. J. Snelus has shown* that when very grey pig-iron is reduced to powder, scales of graphite can be detached from the crystalline faces of the iron, and also that by sifting and levigating the fine borings of grey iron the graphite can be mechanically separated more or less perfectly. The action of acids upon pig-iron varies with the state in which the carbon exists in the pig-; thus, upon treatment with hydrochloric acid the metal is dissolved, and any combined or dissolved carbon unites with the hydrogen of the acid to the formation of gaseous and liquid hydrocarbons, of which the latter are very volatile, of a brown colour, and possess a most disagreeable odour; at the same time the graphite or uncombined carbon remains along with the silica, as an insoluble residue; hence, when grey cast-iron is thus treated, a large proportion of its carbon remains as graphite in the insoluble residue,

* Proceedings of the Iron and Steel Institute, 1871.

whilst if white iron be similarly treated, only a small proportion of its carbon remains in the insoluble residue, the greater portion having combined with hydrogen, as above mentioned, and escaped in the gaseous form during the solution.

97. That white cast-iron is a definite carbide of iron of the formula Fe_4C , which would represent about 5.08 per cent. of carbon, has been maintained by Karsten, but the evidence advanced does not appear sufficient to warrant the assumption of any such atomic combination occurring in the commercial varieties of pig-iron. Grey pig-iron can be rendered white by a variety of operations; thus by rapid or sudden cooling, as by pouring the fluid metal into cold metallic moulds, as in the familiar instance of chill casting; but under these circumstances the conversion into white iron often extends but to a small depth into the body of the casting, and such castings, upon breaking, present a white hard skin enveloping a grey soft interior. When grey cast-iron in mass is allowed to cool *slowly* from a state of fusion, as in the case of the fluid metal standing in a foundry ladle, a large amount of graphitic matter known as "*Kish*" separates and rises to the surface as the metal cools, whilst if this same metal be run into moulds and cooled *quickly*, the greater portion of this carbon remains unseparated from the iron, thus indicating that the fluid cast-iron is capable of holding in solution an amount of carbon which separates if the metal be allowed to cool slowly.

98. *Ferrous carbonate* (Fe CO_3) is metallurgically one of the most important salts of iron, since the anhydrous ferrous carbonate occurs crystallised as Siderite or spathic iron ore, and in its amorphous form it is the usual chemical combination under which a large proportion of the iron occurs in the various clay ironstones. When speaking of iron-rust (p. 42), it was explained how ferrous carbonate was first produced when iron was exposed to the joint action of atmospheric air or oxygen, moisture and carbonic anhydride (CO_2), and how by

further exposure the ferrous carbonate was again decomposed, with the deposition of hydrated ferric oxide, or iron-rust. Ferrous carbonate is slightly soluble in water, but more so in water containing free carbonic anhydride, and this solution on exposure to the atmosphere suffers decomposition, with deposition of the hydrated ferrous oxide as before mentioned. Ferrous carbonate is also decomposed at a red heat in the absence of air or oxygen, with the production of magnetic oxide of iron (Fe_3O_4), and the liberation of carbonic oxide (CO) and carbonic anhydride (CO_2) gases, thus : $3 (\text{Fe}, \text{CO}_3) = \text{Fe}_3\text{O}_4 + 2 \text{CO}_2 + \text{CO}$.

99. Sulphur and iron, by their union under special chemical conditions, may be made to yield a considerable number of sulphides of iron. The direct combination of sulphur and iron results when these elements are brought into contact under the influence of heat, the combination being attended with a considerable further evolution of heat; and according to the proportions of the elements present, and to the temperature employed, ferrous sulphide (FeS), ferric sulphide (Fe_2S_3), ferric disulphide (FeS_2), or magnetic sulphide (Fe_3S_4), or a mixture of these several sulphides, results. The higher the temperature employed the lower is the degree of sulphurisation of the products; also, since ferrous sulphide (FeS) dissolves both iron and sulphur, if either be present in excess, the composition of the body resulting from the heating together of iron and sulphur is exceedingly variable. Mr. Parry has shown that pig-iron heated in a tube filled with the vapour of sulphur absorbs a portion of the sulphur, which it retains even after heating in vacuo during several hours; and hence it is inferred that sulphur may be in this manner imparted to the metal in the blast furnace, or in other furnaces where sulphurous ores and fuels are employed.

100. The effect of small quantities of *sulphur in pig-iron* is to make the iron stronger and whiter, and its presence may be thus advantageous in the metal to be used in the foundry for special classes of castings, such as

shot, &c. ; but the presence of very small quantities of *sulphur in wrought-iron or steel* is attended with the worst results, 0·2 per cent. of sulphur sufficing to produce in iron or steel a marked *red-shortness*, or impaired malleability at a red heat ; whilst the same metal may be hammered or rolled in the cold state with perfect facility. Since iron pyrites is a frequent impurity in the ores and coal used in the production of iron, it becomes necessary when such ores or fuels have been used to take special care that only such processes are employed for the conversion of the pig-iron into malleable iron or steel as will eliminate the sulphur during the process of its conversion, and so prevent the production of red-short malleable iron or steel. Pig-iron produced from Cleveland ores usually contains from 0·02 to 0·1 per cent. of sulphur ; but, when *forge-cinder* is added to the charge of ore in the blast furnace, then it is found that the common forge-pig resulting often contains as much as 0·7 per cent. of sulphur.

101. Ferrous sulphide (FeS) is a usual constituent of the ores of nickel and copper, as in nickel and copper pyrites, but it never occurs free in nature. It can be prepared artificially as previously mentioned by the direct union of sulphur with iron at a red heat ; by heating to redness ferrous sulphate in a charcoal-lined crucible ; by the ignition of hammer-scale with sulphur ; or, by the precipitation of a ferrous salt by an alkaline sulphide. As artificially prepared by the dry methods above enumerated, it forms a very dark brown or black body, having a semi-metallic lustre. It is not sensibly affected by exposure to the atmosphere at ordinary temperatures ; but, if heated slightly, as in the operation of roasting, it suffers partial oxidation and ferrous sulphate results, whilst, at a higher temperature, the latter salt is decomposed with the production of ferric oxide (Fe_2O_3) and the liberation of sulphurous and sulphuric anhydrides ; and, if the ferrous or ferric sulphate and ferrous sulphide be present in the mixture

in equivalent proportions, then, upon strongly heating the mixture, the whole of the sulphur from both the sulphide and the sulphate escapes as sulphurous anhydride, and ferric oxide alone remains. When heated with carbon, ferrous sulphide is but slightly acted upon; or, if ferric oxide be substituted for the carbon, then a portion of the sulphur is eliminated as sulphurous anhydride, but there is no reduction of metallic iron. Ferrous sulphide is not affected by heating with silica alone, but if carbon be also present then the ferrous sulphide suffers decomposition largely.

102. **Ferrous disulphide** (FeS_2) constitutes the familiar brass-yellow mineral occurring in radiated fibrous masses, having a strong metallic lustre, and known generally as *yellow iron pyrites*, *cubic pyrites*, or *mundic*; also, in its softer and whiter form, as *marcasite*, or *white iron pyrites*. Heated with access of air, iron pyrites is decomposed with the evolution of sulphurous anhydride (SO_2), in which way it is commonly employed as the source of sulphurous anhydride in the manufacture of sulphuric acid, whilst the residues so obtained, and known as "*Blue Billy*," are used as a fettling for the puddling furnaces in the Cleveland district.

103. **Magnetic pyrites** or *pyrrhotine* occurs native, associated like the other sulphides of iron with the ores of nickel and copper, but it has no special metallurgical importance.

104. **Iron and phosphorus** unite with the utmost facility under the influence of heat, producing readily fusible phosphides of a grey colour. A ferrous phosphide also results when ferrous phosphate is heated to a high temperature along with carbon. Pig-iron also absorbs phosphorus when heated in the vapour of the latter.

105. The chemistry of the numerous definite phosphides of iron that can be prepared by purely chemical methods is not of metallurgical importance, although the presence of very small proportions of phosphorus in any

of the commercial forms of iron, whether as pig-iron, malleable iron, or steel, is attended by important and usually most injurious results. In the blast furnace almost the whole of the phosphorus present in the ores and fuels of the furnace-charge passes into the pig-iron produced, unless the furnace be working upon a highly basic slag or scouring cinder containing much iron, when a portion of the phosphorus will pass out in the slag, probably in the form of a phosphate; but when the slag is in its normal grey condition, almost the whole of the phosphorus appears to pass into the pig-iron. Hence ores containing a notable amount of phosphorus are only available, unless the blast furnace be allowed to work as before described upon a basic slag, for the production of pig-iron of forge quality for puddling purposes; for foundry purposes where castings of delicate forms but of little strength are required; for the production of a special pig available for the basic Bessemer process; or for certain other special purposes.

106. The influence of phosphorus in pig-iron, malleable iron, and steel is more fully detailed at pp. 72, 207, 393, respectively; and it will suffice here to note generally, that its presence in pig-iron renders the iron more fluid when in the molten state, and thus well adapted for casting light and delicate ornamental castings, but such iron is also very weak, and not adapted to the production of strong heavy castings.

107. In malleable iron and steel, small proportions of phosphorus suffice to render the metal sensibly harder, without materially affecting its tenacity, but it renders the metal at the same time decidedly *cold-short*. Cold-short metal cracks and breaks, especially at the edges, when treated under the hammer, although such material may be readily worked by hammering or rolling when suitably heated; but, if in malleable iron or steel the proportion of phosphorus attains to 0.5 per cent. or upwards, then, in addition to being cold-short, the metal also shows a marked falling-off in tensile strength. The late Mr

A. L. Holly, C.E., of the United States, concluded from his experiments that the effect of phosphorus varied much according to the proportion of the other impurities present, so that, in iron containing not more than 0.15 per cent. of silicon, or 0.03 per cent. of carbon, phosphorus up to 0.2 per cent. might be present without injury to the metal.

108. Silicon is always present more or less in all varieties of commercial iron, either in combination with the metal, or, as in the case of malleable iron, it may possibly occur only as a constituent of the intermixed cinder in such iron.

109. A compound of iron, silicon, and carbon results when oxide of iron and silica in the form of sand are simultaneously reduced by heating a mixture of these bodies along with carbon, to the temperature of a wind-furnace; or a like compound is obtained by heating silica, iron, and carbon to the same high temperature; or by treating such a mixture in a Siemens gas furnace. Mr. Riley has prepared an alloy or pig-iron, containing as much as 21 per cent. of silicon, which alloy presents a bright grey or silvery-white colour, and is crystalline, hard, and so brittle that it might be pulverised in a mortar.

110. Authorities differ as to the condition in which silicon exists in pig-iron, some maintaining that in dark-grey pig-iron, silicon, like carbon, exists both in the chemically combined and in the graphitic state; whilst others are of opinion that it never occurs except in the state of chemical union with the iron; and experimenters have not yet been able to separate by mechanical means the silicon from pig-iron in the same manner as graphite has been separated.

111. Silica always suffers reduction in the blast furnace, in amount proportionate to the quantity of carbon present in the furnace, and to the increase in temperature attained; hence the pig-iron produced in the blast furnace is, as already mentioned, always contaminated with silicon, and with every increase in the temperature of the

blast there is a corresponding increase in the proportion of silicon reduced and entering the pig-iron; so that hot-blast pig is always more highly siliceous than cold-blast, and grey iron, as requiring a higher temperature for its production, is also more siliceous than the white iron produced in the same furnace. The excess of fuel employed when first blowing in a furnace often results in the metal first tapped being more highly siliceous than that produced in subsequent workings, and, under these conditions, the siliceous pig known as *glazed* or *blazed pig* often results. Poor ores and smelting materials are also conditions favourable to the production of a siliceous iron; and further, siliceous pig is more frequently produced when the furnace is working upon very refractory ores.

The mechanical and chemical influence of silicon upon pig-iron, malleable iron, and steel will be more fully spoken of when treating of those metals (pp. 72, 207, 394).

112. **Ferrous silicates** of variable composition are formed as the result of the union of oxygen with silicon and iron; and thus the various slags and cinders produced in the blast furnace, the puddling, refining, re-heating, or other furnaces employed in the production or subsequent manipulation of iron are essentially ferrous silicates. Pure silica and oxide of iron unite at a white-heat to the production of a fusible ferrous silicate, and in this manner, during the ordinary operation of welding together two pieces of iron, the blacksmith removes the oxide or scale, which during the process of heating the iron in the smith's fire forms upon the surfaces of the bar to be welded, by throwing upon the heated surface a quantity of siliceous sand, whereby a readily-fusible ferrous silicate is produced, which flows away under the pressure of the hammer or press employed in welding together the two surfaces of the metal, and so leaves the two surfaces to be united quite clean and in the best condition for being successfully welded.

113. *Ferrous silicate* (2FeO SiO_2) yields about 70 per

cent. of ferrous oxide and 30 per cent. of silica; it melts at a white heat, but if heated with access of air it suffers partial decomposition, with the production of ferric oxide and the separation of silica. Thus *tap-*, *forge-*, or *mill-cinder*—*i.e.*, the slag of either the puddling or re-heating furnace—which is essentially a ferrous silicate of the above formula, yields, when roasted with access of air during several days in suitable kilns or ovens, a highly refractory dark grey and lustrous body, consisting essentially of ferric or magnetic oxide, with small proportions only of silica. The roasted tap-cinder is known as “*bull-dog*,” and is used largely for making the bottom of the puddling furnaces; and it may be noticed in passing that, during the roasting of the tap- or forge-cinder from the puddling furnace for the production of bull-dog, there liquates from the mass two other products: the one which collects in the bottom of the kiln, and is known as “*bull-dog slag*,” is more siliceous than “*bull-dog*,” and carries with it much of the phosphorus contained in the cinder; whilst the other product is still more siliceous, and runs away from suitable openings left in the kiln for the purpose, carrying with it also the larger proportion of the phosphorus contained so largely in the slag or cinder of the puddling furnace.

114. The inferior class of pig-iron occurring in the market under the name of *Cinder-pig* in contradistinction to *all mine pig*—*i.e.*, pig smelted entirely from *ore* or *mine*—is obtained by treating in the blast furnace these rich slags or cinders, along with a certain proportion of other inferior ores or mine; and Dr. Percy states that when ferrous silicate of the composition 2 FeO SiO_2 is so treated, or otherwise strongly heated with carbon, about two-thirds of its iron is reduced, leaving behind a more siliceous slag having a composition represented by the formula $2 \text{ FeO } 3 \text{ SiO}_2$; but since, as will subsequently appear, the phosphorus from the pig-iron passes out during the puddling process into the tap-cinder of the puddling furnace, so the pig-iron (*cinder-pig*) produced by smelting

such slags and cinders is also proportionately contaminated more largely with phosphorus, and is hence of decidedly inferior quality.

115. Iron and Nitrogen are usually described in chemical works as yielding two or more distinct nitrides of iron. When iron-wire is heated to redness for some hours in a current of dry ammoniacal gas, the wire so treated is stated by Despretz, Fremy, Savart, and Dick to gain slightly in weight, to be more brittle, and less alterable by exposure to the atmosphere than pure iron, and to become also whiter in colour; whilst Savart adds, that after attaining to this condition, if it be longer exposed to the ammoniacal vapour, the metal assumes a dark-grey colour, becomes soft, has a graphitic fracture, and will not harden in water. The evidence as to the exact increase in weight of the iron by the above treatment is very contradictory, the statements ranging between 0·2 to 12 or 13 per cent., and from such evidence it is impossible to state whether nitrogen does or does not play any important part, as is sometimes understood, in the process of cementation for the conversion of bar-iron into blister-steel.

116. Bois and Boussingault have examined commercial iron and steel for nitrogen, and state that they find from 0·005 to 0·124 per cent. of nitrogen in all specimens. The gases occluded by steel, and contained in the blow-holes or honeycombs of steel ingots, have been analysed by Mr. Parry, Mr. Stead, and others, and they find such gases to yield from 10 to 15 per cent. of their volume of nitrogen.

117. Iron and many of the other metals unite with great facility to form alloys; thus, for instance, when the ores of iron and of a second metal are simultaneously reduced, an alloy of the two metals often results, though with but few exceptions these alloys are without commercial importance; and further, the alloys of pure iron and the various metals hereinafter enumerated are but little known, only the triple alloys of carbon, iron, and other metals having been much studied.

118. **Manganese** is a constant constituent of pig-iron and of steel, but of the alloy of pure iron with manganese very little is known, whilst with pig-iron its alloys are of very considerable importance. As *spiegeleisen*, or white iron containing from 8 to 15 per cent. of manganese, it is a regular article of commerce; whilst more latterly special alloys known as *ferromanganese*, containing from 50 to 75 per cent. of manganese, have been the objects of a regular manufacture for use in the production of mild steel, principally by the Bessemer and Siemens processes. The especial application of ferromanganese to these processes will be subsequently referred to, as will also the effects of manganese upon cast-iron (p. 74), upon malleable iron (p. 204), and upon steel (p. 394). The presence of manganese in iron ores is favourable to the elimination of sulphur from the pig-iron produced from such ores, but its influence, if any, is small in diminishing the amount of phosphorus passing into the pig-iron.

119. **Tungsten and iron** unite readily, when tungsten is reduced from its compounds by carbon in the presence of metallic iron, but a very elevated temperature is required for the reduction. Thus, if grey pig-iron be heated to a very high temperature in a closed crucible along with tungstic oxide, the tungsten is reduced by the graphite of the pig-iron, and then unites with the iron present, with the production of a hard, fine-grained, almost silver-white steel of great tenacity and considerable malleability; if the same experiment be repeated with white-iron or spiegel-eisen containing only very small proportions of graphitic carbon, it is found, the conditions being otherwise the same, that little or no tungsten is reduced, indicating that combined carbon in pig-iron does not effect the reduction of tungsten from tungstic oxide. For further information respecting the effect of tungsten upon steel, refer to p. 395.

120. **Chromium**, when alloyed with iron, decreases the fusibility of the metal, and like tungsten is said also to

increase the tenacity, malleability, and ductility of the steel in which it occurs. Chromium appears to partially replace carbon in steel.

121. Copper does not readily unite for the production of a homogeneous alloy by the simple fusion of any mixture of the two metals, but if iron be added in small quantities to brass or bronze in a state of fusion it is readily taken up, and the resulting alloy has a higher tensile strength than the original brass. An apparently homogeneous alloy of copper and iron seems to result upon the simultaneous reduction of a mixture of the oxides of copper and iron, the former being always maintained in excess. Copper in small quantities renders malleable iron or steel *red-short*, and sensibly diminishes its tenacity, while pig-irons containing copper are unfit for conversion into malleable iron or steel.

122. *Aich-metal* is a malleable, ductile, and tenacious alloy of copper, zinc, and iron in the proportions of about 60 per cent. of the first mentioned, with 38 to 44 per cent. of zinc, and from 0.5 to 3 per cent. of iron. *Sterro-metal* is a similar alloy containing from 2 to 4 per cent. of iron introduced in the form of malleable iron, with from 1 to 2 per cent. of tin; such an alloy is brass-yellow in colour, and has been proposed on account of its high elasticity, tensile strength, and the facility with which it may be worked either hot or cold, as a material for the construction of ordnance, but its introduction has not, however, been favourably received.

123. Zinc and iron yield, when heated together, more or less crystalline, brittle, and friable alloys, which, however, are without practical application to the arts, and are more properly zinc alloys, since about 7 per cent. is the maximum amount of iron that molten zinc will take up; but the manufacture of *galvanised* or *zincd plates*—that is, plates coated with a thin layer of zinc, or with an alloy of zinc and iron—form an important branch of metallurgical industry. Galvanised plates, whilst possessing the strength due to

the iron, are not affected on exposure to atmospheric influences by rusting or corrosion, so long as the zinc coating remains intact. The galvanising process is effected by dipping the malleable iron plates, previously cleansed from scale or rust by immersion in dilute sulphuric acid, into a bath of molten zinc the surface of which is covered by sal-ammoniac (NH_4Cl); under these conditions the surface of the iron plate becomes coated or alloyed with a thin protecting layer or coating of zinc, or of a zinc alloy.

124. Tin and iron unite when heated together, with the production of grey or white alloys, which are harder than tin, and break with a crystalline or granular fracture. In this manner alloys of the two metals in almost any proportions may be obtained, but like the alloys of zinc, they are also without practical application to the arts, although in the production of *Terne-plates* the surface of an iron plate is coated by dipping it when cleaned into a bath of molten tin, whereby a firmly adherent non-oxidisable coating of a stanniferous alloy covers the surface of the iron. Small quantities of tin in malleable iron or steel suffice to render the same cold-short; and also only workable with great care even at a red heat, such metal being also brittle, and exceedingly difficult to weld.

125. Antimony can be readily alloyed with iron, but its presence in wrought-iron, to the extent of only 0.2 or 0.3 per cent., is sufficient to render the iron both *red-short* and *cold-short*.

126. Nickel also may be readily alloyed with iron, by the direct fusion of the two metals, or by the simultaneous reduction of their mixed oxides. The presence of nickel in iron does not affect its malleability, but the alloy is whiter in colour than pure iron, is not so easily affected by exposure to air or moisture, and takes a better polish than iron. A native alloy of nickel and iron with other metals occurs in the meteoric masses which are occasionally found.

127. Cobalt, like nickel, readily alloys itself with iron, producing similar alloys to those last described; and small quantities do not produce any material alteration in the physical or working qualities of the iron or steel.

128. Lead does not appear to unite with iron when the two are melted together, and no satisfactory alloy has been described of these metals.

129. Aluminum yields, with steel, alloys of various composition, but they are without value or practical application to the arts. The effect of aluminum upon steel is to diminish the tensile strength of the latter.

130. Silver does not appear to unite with iron when melted along with it, for the silver is found, upon solidification of the fused mixture, to have separated throughout the mass, and not to have produced any homogeneous alloy of the metals.

131. Gold alloys itself readily with iron, upon simple fusion together of the two metals, the alloy being harder than malleable iron.

132. Platinum alloys with iron without difficulty, the melting-point of the alloy being below that of steel. Steel containing 1 per cent. of platinum is tough, fine-grained, tenacious, and ductile. Similar alloys are also obtainable by the substitution of small quantities of the rarer metals *palladium* and *rhodium*.

CHAPTER V.

CAST- OR PIG-IRON.

133. Pig-iron is the form in which the product of the treatment of iron ores, with fuel and fluxes in the blast furnace, occurs in commerce. It is a granular crystalline compound of iron with carbon, silicon, sulphur, phosphorus, and manganese, with oftentimes also smaller

quantities of other metals, such as arsenic, titanium, copper, chromium, &c. Owing to the very high temperatures employed in the reduction of the ores of iron in the modern blast furnace, the iron is never obtained free from other elements, but in the first instance is always combined with more or less of the reducing agent (carbon), along with the other elements just enumerated derived from the ores, fluxes, or fuels employed in the smelting operation.

134. Pig-iron is thus essentially a combination of iron with from 2 to 4.75 per cent. of carbon, existing partly in a state of solution or chemical combination with the iron, and partially as mechanically-distributed *uncombined* or *graphitic* carbon. All pig-iron contains carbon in the two forms, but the relative proportions of the combined to the uncombined carbon vary in different varieties of pig-iron, from the greyest iron where the carbon is almost wholly in the *uncombined* form, to the hardest white iron in which only a small proportion of the carbon exists in the graphitic or uncombined form; but the maximum amount of carbon in both forms never exceeds, according to Riley, 4.75 per cent. Upon the relative proportions of the two forms of carbon, modified by the presence, mode of occurrence, and varying proportions of the foreign elements above-mentioned, depend the wide variations in the colour, hardness, strength, fusibility, specific gravity, behaviour when treated with acids, and adaptability of the metal to special purposes, in the manner to be immediately described; but in all its varieties it differs from malleable iron and steel by an almost total *absence of ductility*, in being *unforgeable*, and it does not admit of being welded; it is also more brittle, not so tough, and is usually harder than malleable iron.

135. As mentioned in the preceding section, pig-iron represents iron in its maximum state of carburisation, containing, as shown by the analyses tabulated on p. 64, from 2 to 4.75 per cent. of carbon. It is upon

the mode of occurrence of this carbon, as to whether it exists largely in the graphitic or uncombined form with only small proportions of combined carbon, or whether it exists principally as combined carbon with only small proportions of graphite, that the well-marked physical distinctions of *grey*, *white*, and *mottled* iron respectively depend. The greyest iron corresponds to the largest proportion of graphitic carbon, and the larger the proportion of graphite in grey iron, the weaker and more pliable does the metal become. The graphitic carbon in grey pig-iron may be seen under a powerful microscope to be distributed over the faces of the crystals of the iron in the form of very thin plates. White iron, again, corresponds to the condition of the largest proportion of combined or dissolved carbon, with smaller proportions only existing in the uncombined or graphitic state; and between the two extremes of grey and white iron the gradation is more or less gradual, although at certain intermediate stages the metal exhibits white iron dispersed through a matrix of grey, giving to such metal a decidedly mottled appearance, and such pig is accordingly described as *mottled pig-iron*. Since much of the carbon in white iron is either dissolved or chemically combined with the iron, it has been suggested that such iron might possibly be a definite carbide of iron, but there is no conclusive evidence of the existence of any such well-defined carbide, although spiegeleisen may perhaps be a double carbide of iron and manganese of the formula $(\text{FeMn})_2\text{C}$.

136. Pig-iron, in cooling from a state of fusion, crystallises either in rhomboidal prisms or in octahedral crystals, and in most varieties one or other form is predominant; thus the dominating form of crystals in grey iron is the octahedral. The specific gravity of pig-iron varies also from 7.1 in grey to 7.5 in white iron.

137. Pig-iron is usually found in commerce in the form of oblong blocks or pigs of  section, about three feet in length, the metal being run direct from the blast-

furnace into open grooves, or channels of the above section, formed in the damp sand of the pig-bed (*see* p. 129) in front of the furnace. Such pigs, when broken by the hammer, or by dropping them across a Δ shaped block, present, if grey iron be the subject of operation, a dark grey, granular, crystalline or scaly fracture, with a strong metallic lustre; whilst the colour will be

ANALYSES OF CAST- OR PIG-IRON.

	Grey, all-mine pig.	Bowling, No. 1 grey, cold-blast (Abel).	Hæmatite pig, No. 1 grey (Author).	North- ampton- shire, hot-blast (Henry).
Graphitic carbon . . .	3.10	} 2.99	3.045	1.150
Combined carbon . . .	0.04		0.704	0.554
Silicon	2.16	0.97	2.003	1.900
Sulphur	0.11	0.05	0.008	0.414
Phosphorus	0.63	0.50	0.037	1.807
Manganese	0.50	—	0.309	0.395
Titanium	—	—	—	—
Metallic iron	94.56	—	93.800	93.780
	101.10	—	99.906	100.000
	Butterly, hot-blast, from Derby- shire ores.	Kirkless Hall, No. 3 pig- iron.	West Hallam, Derby- shire, No. 3 foundry (White- house).	North Stafford- shire, hot-blast (William- son).
Graphitic carbon . . .	3.35	3.25	2.60	2.54
Combined carbon . . .	—	—	—	—
Silicon	1.27	2.70	1.26	2.71
Sulphur	0.02	0.08	0.05	0.04
Phosphorus	1.09	1.73	0.72	1.07
Manganese	1.01	2.37	0.45	0.98
Metallic iron	93.26	89.90	94.92	92.66
	100.00	100.03	100.00	100.00

ANALYSES OF CAST- OR PIG-IRON (*continued*).

	Cleveland, No. 2 foundry, hot-blast (Abel).	Bessemer pig, No. 2 grey (Author)	Grey cinder-pig (Noad).	No. 4 forge hot-blast (Stock).
Graphitic carbon . . . }	3.44	2.579	2.80	2.719
Combined carbon . . . }		1.175		1.222
Silicon	1.13	1.758	1.85	1.608
Sulphur	0.03	0.014	0.14	0.031
Phosphorus	1.24	0.038	1.66	0.016
Manganese	0.43	0.130	—	0.021
Calcium	—	—	—	0.074
Metallic iron	93.73	94.304	93.55	94.309
	100.00	99.998	100.00	100.000

	Mottled charcoal pig (Rost- horn).	Mottled pig.	White- pig-iron.	Spiegel- eisen (Tookey).
Graphitic carbon	2.02	1.99	0.87	5.04
Combined carbon	1.43	2.78	2.46	
Silicon	0.92	0.71	1.12	0.41
Sulphur	0.04	trace	2.52	0.08
Phosphorus	0.04	1.23	0.91	0.16
Manganese	2.02	—	2.72	7.57
Metallic iron	94.08	93.29	—	86.74
	100.55	100.00	—	100.00

	Styrian white-pig.	Joachims- thal white pig-iron.	Cleveland, No. 1, (Pattin- son).	Cleveland, No. 4 (Pattin- son).
Graphitic carbon	} 2.93	3.60	2.83	2.45
Combined carbon			0.48	0.26
Silicon	0.307	0.66	2.31	1.87
Sulphur	0.018	0.021	0.04	trace
Phosphorus	0.021	0.52	0.30	1.00
Manganese	0.724	0.531	0.57	0.93
Metallic iron	96.000	95.136	93.03	94.64
	100.000	100.468	99.56	101.15

of a lighter grey, less lustrous, and the metal harder and more brittle, as the proportion of combined carbon increases, and the uncombined or graphitic carbon becomes less.

138. The *mottled varieties* stand intermediate between the two extremes of grey and white iron and exhibit a decidedly veined or mottled fracture, as though the white iron were distributed in small detached portions, or in veins, throughout a matrix of grey iron; and according as the proportion of white iron increases or otherwise, the pig-iron is described as *strongly* or *weakly mottled*. Grey iron is more fluid when melted than white iron, but it requires a much higher temperature for its fusion; thus, whilst grey iron only melts at a temperature of about 1,600° C. or 1,700° C. (2,912° Fahr. to 3,452° Fahr.), white iron melts at a temperature of from 1,400° C. to 1,500° C. (2,532° Fahr. to 2,732° Fahr.). White iron contracts in passing from the liquid to the solid state, and it passes through a soft pasty condition before complete fusion occurs, as also through a similar condition in assuming the solid state after fusion; and these qualities are, as will subsequently appear, the best adapted for the better carrying on of the processes of puddling and of refining of pig-iron for its conversion into malleable iron, for which purposes white iron is largely applied. Grey iron, on the other hand, passes during fusion directly from the solid to the fluid state, and *vice versa*, and it also expands at the moment of its solidification from the fluid state, thus insinuating itself into the finest lines of the moulds in which it is contained, whilst white iron, as just stated, contracts under these circumstances. Hence grey pig-iron is in request for foundry purposes, and more especially for the production of the light ornamental and intricate castings of every-day production, so that it has thus become usual to speak of the softer grades of pig-iron as *foundry pig*, in contradistinction to the harder and whiter varieties, which are described as *forge qualities*.

139. Mallet,* however, argues that the fine copies of

* Proceedings of the Royal Society, 1875.

the moulds obtained with cast-iron are not necessarily the result of any such expansion of the metal as that just spoken of as taking place at the moment of its solidification, but that the phenomenon is otherwise explicable; and he sums up the favourable position held by cast-iron over other metals for taking accurate copies of the moulds as follows, viz. : That its density is sufficient to force it when liquid effectually into the corners of the mould; its capillarity is not very large, and so it does not require so great a force to press it into the angular cavities of the mould; its range of viscosity is small, and confined to a small range of temperature; and further, that any oxide formed during the casting process is precluded by the silicon and carbon of the metal from distributing itself throughout the mass.

140. *Silicon* is an almost invariable constituent of pig-iron, as are also sulphur and manganese. Cast-iron expands in length by heating and then cooling suddenly in water, or also by gradually cooling in the air.* Like steel, cast-iron appears to have the power whilst in its fused state of occluding certain gases, and especially hydrogen; but the gases are to a certain degree again liberated as the metal assumes the solid state, and hence one of the causes to which the honeycombed or unsound structure so frequently observed in cast-iron or steel castings is attributable. When atmospheric air (as in the Bessemer process for the conversion of pig-iron into steel) is blown or forced through molten grey pig-iron, it is attended with the production of an intense heat, whilst the carbon, silicon, and manganese of the pig-iron are largely oxidised and removed in the manner to be more fully described when speaking of the Bessemer process. Cold solid cast-iron floats upon the surface of the molten metal, and it has been usual to ascribe this result to the superior density of the fluid over the solid metal, but it is observed that with the larger pieces of solid cast-iron, they first sink and then rise again to the

* Mr. Wrightson : Proceedings of Iron and Steel Institute, 1879.

surface* of the molten metal; and hence it is now considered probable that the buoyancy is due to a decrease in its density, owing to the sudden expansion of the solid metal from contact with the much larger body of molten iron into which the cold metal is introduced. Pig- or cast-iron suffers decomposition when exposed to the action of sea-water, or more rapidly when exposed to the joint action of sea-water and of the atmosphere, so that if the exposure be sufficiently prolonged it will be left as a soft porous mass having the form of the original specimen, and which in some instances, after careful drying, becomes spontaneously inflammable.

141. Grey cast- or pig-iron is converted into white iron by rapid or sudden cooling, as in the familiar process of chill casting, where the fluid metal is poured into metallic moulds, and the heat is thus rapidly withdrawn from the surface, whereby the surface of the casting is converted into hard white iron, whilst the body of the castings usually retain the soft character of grey iron; but the depth and degree of the chilling or whitening depend upon the thickness, &c., of the mould. In like manner, it is not unusual to find that the flat plates or pigs of Swedish pig-iron present on fracture a white skin, with a grey interior, produced by the Swedish practice of running the pig metal into cast-iron open moulds. In white iron produced by the chilling of grey iron, the carbon in the chilled surface has largely assumed the combined form instead of the graphitic form previously existing in the grey metal; also the white portion of such castings is found to be poorer † in silicon than the body of the casting. From these and similar reasonings, it is sometimes inferred ‡ that *molten pig-iron may be a solution of various solid and gaseous substances in liquid iron*, and that the form they assume in the solidified metal depends upon the

* W. J. Millar, C.E. : Proceedings of Royal Society of Edinburgh, 1882.

† Crooke's and Rohrig's "Metallurgy."

‡ Zeitschrift des Vereines deutscher Ingenieure, Vol. XXIV., p. 397.

manner of cooling, both before and after solidification; since even after solidification, but whilst the mass is still at a red heat, it is possible to alter the nature of the metal, as by tempering, cementation, or by decarburisation.

142. When a mass of grey iron is allowed to cool slowly from a state of fusion, as in the case of the molten metal standing in a foundry ladle, a scum or *kish* rises to the surface, which consists largely of graphitic matter; whilst, as above stated, if the same metal be run into chilled moulds, and so cooled suddenly, then no separation of the graphite occurs, but the whole of the carbon remains in the metal, a portion of it assuming the combined form with the production of a harder or white metal; hence *fluid* and also *chilled* cast-iron appear to be capable of holding a larger amount of carbon in solution than metal cooled more slowly from a state of fusion. The scum or *kish* produced in the manner just described is also notably rich in sulphur and manganese, containing occasionally as much as 0.22 per cent. of sulphur and 5.19 per cent. of manganese, the relative proportions of these elements in the pig-iron being at the same time 0.05 and 2.62 per cent. respectively.*

143. *Hot-blast* pig-iron, owing to the higher temperature of the furnace during its production, is always more siliceous than cold-blast pig, smelted from the same or a similar mixture of ores, and from the same cause also grey pig-iron is more siliceous than white iron.

144. White iron, as already stated, has a higher specific gravity than grey iron, and hence, when both classes of iron are made in the same furnace in the interval between two taps, the white iron will descend, separate, and form the lower stratum in the hearth of the furnace, so that on tapping the furnace the white iron is the first to run out, throwing off its characteristic showers of sparks, and flowing in a thick sluggish stream, and this is succeeded by the grey iron flowing in a perfectly fluid current devoid of all sparks or splashes.

145. *Pig-iron is largely soluble in acids*, leaving only a

* Professor A. Ledebur, Freiberg School of Mines.

small proportion of insoluble residue, of silicon, graphite, &c., the latter forming a considerable part of such residue when grey pig-iron is the subject of operation; but if white iron be the subject of treatment, then only a small proportion of graphitic carbon is separated in the insoluble residue, since the whole of the combined carbon in the iron escapes in the form of liquid or gaseous hydrocarbons, produced by its combination with the hydrogen of the acid. The liquid hydrocarbons so produced are highly volatile, brown in colour, soluble in alkalis, and possess a most disagreeable odour.

146. *The strength of cast-iron* varies much according to its chemical composition, the mode of its production, whether by hot-blast or cold-blast, mode of treatment after leaving the blast furnace, &c.; thus cold-blast iron is stronger than hot-blast from the same ores. Annealing diminishes the strength of cast-iron; the presence of silicon likewise impairs its tensile strength, whilst sulphur in small quantities increases the strength; but phosphorus, again, if present in any considerable amount, decidedly weakens cast-iron. Repeated re-melting is sometimes considered to improve the quality and strength of cast-iron, but this is now generally questioned. Grey cast-iron, if not contaminated with other bases derived from the fuel or the flux employed in the melting of it (which conditions are improbable in practice), is, for a certain number of meltings, rendered stronger after each re-melting, since at each melting it approaches nearer to the character of white iron, but like white iron, the re-melted pig is not so tough as the original, and is thus not so well adapted for structural work. The *tensile strength* of pig-iron varies between 4 and 14 tons to the square inch of section, but the average of good cast-iron is about 8 tons. The *transverse* and *torsional strength* of pig-iron is low, each varying between 1·5 and 4·5 ton per square inch; and it has an average *shearing strength* of 12 tons to the square inch; whilst its *crushing strength* ranges from 25 to 60 tons per square inch of section,

the average strength of good sound specimens being from 40 to 45 tons per square inch ; but these figures vary with the length of the test-piece employed, the higher figures for the crushing strength being obtained with short test-pieces. Owing to the high strength of cast-iron under a crushing or compressive stress, this metal is usually employed in the constructive arts for columns, struts, &c., and but rarely in such members of a structure as are subject to torsional, tensional, or transverse stresses. Cast-iron is thus stronger than wrought-iron in compression, but much weaker in tension ; and within a limited range of stress it is tougher, or permits of a greater degree of deformation than wrought-iron, but its range of deformation is not large ; hence it is not so safe as wrought-iron when subject to suddenly-applied or impulsive force. The strength of bars of cast-iron under loads suspended from their centre is further spoken of at p. 77.

147. *Sulphur* is most frequently present in pig-iron to the extent of a few hundredths per cent. only ; thus the pig-iron smelted from clay ironstones without any admixture of cinder usually contains from 0·02 to 0·1 per cent. of sulphur ; but in smelting for common forge-pig in South Wales, cinder is sometimes added to the furnace charge, and the sulphur then often reaches as much as 0·7 per cent., and it is notable that the per-centage of sulphur in Welsh pig-iron generally increases with the number or grade of the metal. Pig-iron containing upwards of 0·03 per cent. of sulphur is undesirable for conversion into steel either by the Bessemer or the Siemens process, the steel produced from pig-iron more sulphurous than this being, as previously noted, invariably *red-short* ; but for foundry purposes small per-centages of sulphur increase the tensile strength of the metal ; and hence the practice in Sweden of occasionally adding small quantities of pyrites to the furnace charge when smelting pig-iron for ordnance purposes, the pig-iron thereby produced presenting in fracture a slightly mottled appearance.

148. The effect of sulphur upon pig-iron is generally

to whiten it; and when grey pig is fused with about 2 per cent. of its weight of sulphur, a considerable quantity of carbon is separated in the form of soot, and a hard white iron is produced; or if smaller quantities of sulphur be employed then the iron is less hard, and is mottled in appearance.

149. *Phosphorus* is a constituent of most pig-irons, its tendency being to make the fracture more largely crystalline, and if present in great quantities it reduces the tensile strength of the iron; but in proportions up to 0·5 or 0·75 per cent. it is doubtful whether it has any decided influence upon the strength of cast-iron, whilst 1·5 per cent. of phosphorus produces a pig-iron which is decidedly tender. Phosphorus hardens pig-iron and increases its fluidity when melted, and such pig is therefore well adapted for the manufacture of light castings not requiring great strength. The pig-iron smelted from clay ironstone without admixture with cinder usually contains from 0·25 to 1·5 per cent. of phosphorus; whilst common white iron smelted with a heavy burden of cinder sometimes contains as much as 2 per cent. of phosphorus, and usually presents a honeycombed structure along the upper surface of the pig, whilst generally such metal contains not only phosphorus but also considerable proportions of sulphur. When the blast furnace is working satisfactorily and producing a good grey slag, then the whole of the phosphorus in ore, fuel, and fluxes is reduced and passes into the pig-iron; whilst if the furnace be running on a basic scouring slag or cinder, rich in iron, then a portion of the phosphorus in the charge passes out into such slags.

150. *Silicon* appears to have a similar effect upon pig-iron to that produced by carbon, and, like the latter, it exists in soft grey iron smelted with hot-blast from refractory ores, both in the combined and the graphitic condition; although the mechanical separation of graphitic silicon from pig-iron has not yet been effected; but in white iron or in highly manganiferous iron silicon

appears to exist only in the combined state. Siliceous pig-iron is weak, also somewhat brittle and hard, and thus hot-blast pig being more siliceous than cold-blast metal is also not so strong as the cold-blast iron smelted from the same or a similar mixture of ores. The product of charcoal furnaces such as those of Sweden, owing to the lower temperature attained in them, is less highly siliceous than the pig-iron produced in coke furnaces. Mr. Riley has succeeded in producing a hard, silvery-white alloy of pig-iron and silicon containing 21 per cent. of the last-mentioned element; but silicon is only present in the ordinary product of the blast furnace in amounts varying from 0.1 to as much as 5 per cent.; the higher percentages occurring when siliceous ores, iron-sand, or ores containing free silica are being smelted, or when the furnace is working with an insufficient supply of lime as a flux. Siliceous and weak pig-iron also generally results from the working of poor ores and smelting materials, or when the furnace is working upon charges containing large proportions of fuel to ore—that is, upon light burdens; and thus such iron occurs on first blowing in a furnace, when the proportion of fuel to ore is large, and the first metal is, accordingly, usually poor in quality, highly siliceous, and is known as *glazed* or *blazed* pig-iron.

151. In hæmatite pig-iron for use in the ordinary Bessemer process for the manufacture of steel, about 1 per cent. of silicon is considered the minimum of what is desirable for the successful and most profitable working of the process; but large excesses of silicon are here again objectionable owing to their yielding a hard and brittle steel, as will be fully detailed when speaking of the Bessemer process.

152. *Titanium* frequently occurs in grey pig-iron, but in white iron it has always escaped detection, even when ores containing it have been added to the furnace charge.

153. *Copper* has been detected in pig-iron from the blast furnaces of the south Oural mountains, and although such metal would be unfit for conversion into malleable

iron or steel, yet small proportions up to 0.2 per cent. of copper in pig-iron are said not to affect its quality for foundry purposes.

154. *Tin* renders pig-iron hard and more readily fusible; but stanniferous pig, after treatment in the puddling furnace, yields a malleable iron which is exceedingly cold-short and inferior in quality.

155. *Manganese* is a common constituent of pig-iron, its tendency when present being to render the pig-iron white and brittle. Its presence in iron ores promotes the elimination of sulphur from the pig-iron smelted therefrom; but highly manganiferous and other white irons are only produced from easily reducible ores, and especially from those containing notable proportions of manganese. Thus, the pig-iron smelted from a spathose ore is more highly manganiferous than when hæmatite ores containing manganese are employed; and the state of the oxidation of the manganese in the ore also influences the amount of manganese which occurs in the pig-iron smelted from it. The surface of the stream of pig-iron as it flows from the furnace appears, when manganese is present in notable quantity, as a sheet of burning gas, and such metal also gives off much gas during cooling. Manganese in pig-iron seems to increase the power of the metal to occlude hydrogen, but at the same time this quality is impaired with respect to carbonic oxide. Spiegeleisen is a highly manganiferous pig-iron, containing from 6 to 20 or 30 per cent. of manganese, and usually possessing well-marked physical qualities; thus it is very hard, and its fracture often presents large cleavage planes or lamellar crystals, but spiegeleisen and highly manganiferous iron may also present a granular crystalline fracture void of any cleavage or lamellar structure. The presence in spiegeleisen of a large proportion of combined carbon has given rise to the supposition of its being possibly a definite tetracarbide of iron and manganese of the formula $(\text{FeMn})_4\text{C}$. Formerly this material

was manufactured exclusively upon the Continent, but it is now extensively made in this country, although its production, even when smelted where suitable ores are available, requires some care. Thus a too siliceous slag, also variations in the temperature or pressure of the blast, or too heavy a burden in the furnace, will turn the make of the furnace from spiegeleisen to ordinary white or mottled iron.

156. *Ferromanganese* is still more manganiferous than spiegeleisen, and contains as much as from 70 to 85 per cent. of manganese; but with the increased demand for very soft, mild, weldable steel, such an alloy has become a more and more important commercial commodity; its production in the blast furnace is, however, attended with a much larger consumption of fuel, and a greatly decreased yield of the furnace, than when common pig-iron is being produced. For the production of ferromanganese, besides using only suitable ores as already named, a more basic slag or cinder is required, and hence the furnace is burdened with a larger proportion of limestone than is employed in smelting the other classes of pig-iron, whilst the pressure and temperature of the blast are also raised.

157. **Commercial classification of pig-iron.**—It is usual to distinguish the various qualities of pig-iron as delivered from the blast furnace by different marks or numbers, which indicate to the forge or foundry manager the grade or quality of the iron of any particular brand, as also the purposes to which the several samples are applicable. As already noted, the pig-iron produced from the same ores is broadly described as grey, mottled, or white iron, according to the appearance of the fracture, but each variety is again further classified. Thus in the Cleveland district, according to the colour, strength, and general appearance of the fracture of a freshly-broken pig, the metal is described as being of No. 1, No. 2, No. 3, No. 4, or No. 4 forge; whilst in Lancashire the No. 4 forge, or strong forge of the Cleveland district, is represented by V, whilst the other

numbers or grades are designated by the same series of numbers in the two districts. In furnaces making pig from hæmatite ores, or such as from their immunity from sulphur and phosphorus are especially adapted to the production of steel by the ordinary Siemens or Bessemer process, three additional numbers are introduced to designate them, and such pig-iron is described as of No. 1, No. 2, or No. 3 Hæmatite or Bessemer quality of pig-iron.

158. No. 1, No. 2, and No. 3 grades of pig-iron, are especially applicable to foundry purposes and for special castings; No. 4 is also available for foundry purposes, especially when mixed along with other softer irons; whilst No. 4 Forge or V is only applicable for conversion into malleable iron in the puddling furnace, and cannot be advantageously used for foundry requirements. The market value of the several grades thus decreases from No. 1 to No. 4, the higher number being the cheaper iron.

159. When judging of the quality of pig-iron from its fractured surface, it is usual to consider a uniform dark-grey colour, with strong metallic lustre, to be indicative of toughness; whilst a dark colour, an absence of metallic lustre, with a dull more or less leaden hue, and a slightly mottled appearance, indicates a weak iron; but if the iron be light grey in colour, with a high lustre, then it will be strong and tenacious; whilst a light grey colour, without lustre, shows an iron which is hard and brittle, the brittleness being more strongly marked as the iron becomes of a dull white or greyish-white colour.

160. No. 1 pig-iron is the darkest grey, its fracture being largely granular and presenting numerous graphitic planes. It contains the maximum proportion of graphite, is the most readily fusible, is deficient in hardness and strength, and the pig breaks with a dull leaden sound, indicating but little tenacity. This metal makes the finest and most accurate castings, and is hence used extensively for the production of light, thin, and ornamental cast-iron work where great strength is not required. The surface of the molten metal is dark

and sluggish-looking, giving off neither sparks nor splashes, and as it cools in mass a thick scum or dross separates on its surface.

161. No. 2 pig-iron is lighter in colour than No. 1; usually the surface of the pig is smoother, it is finer in grain, more regular in fracture, and is a little harder and stronger than No. 1, but is not quite so fluid when in the molten state. The surface of the molten metal is of a clearer red than No. 1, and it flows from the founder's ladle in large sheets, splashing a little, and its surface exhibits as it cools a series of lines or figures ever varying as though the surface were in circulation, such appearances continuing until the metal becomes pasty. A scum rises to the surface of molten No. 2 pig-iron, but not to the same extent as in No. 1.

162. No. 3 pig-iron is still lighter in colour, the crystals are much smaller, the fracture smoother, more compact and dense-looking; it is also much harder, stronger, and tougher than the lower numbers, and is consequently largely used in conjunction with scrap for the large castings required in structural ironwork, the usual specification test for which is that a bar, two inches deep by one inch in width, supported upon three-foot centres, shall not break with a less weight than twenty-eight cwts. applied at centre; although some engineers will accept a load of twenty-four cwts., whilst others specify thirty-two cwts. as the breaking load; but this latter is extremely difficult to obtain with ordinary *hot-blast* pig-iron. No. 3 pig-iron usually contains less carbon than No. 1 or No. 2, and has not the same fluidity when melted, whilst the molten metal throws off sparks abundantly as it is poured from the foundry ladle, and its surface is freer from scum than either of the lower numbers, but the surface-figuring spoken of with respect to No. 2 is much less distinctly seen with the metal of No. 3 grade.

163. No. 4 iron is stronger than those previously described; it is whiter in colour, more lustrous, has a granular, uneven, and more or less mottled appearance on

fracture; it is not nearly so fluid when melted as the lower numbers, whilst the surface of the molten metal appears hotter, and the metal throws out showers of sparks as it is poured from the casting ladle. No. 4 pig-iron is used only for the heaviest classes of foundry work, and is quite unsuitable for small, light, or ornamental castings.

164. No. 4 Forge, strong forge-pig or V, approaches to whiteness in colour, being harder and also lighter in colour than the last. This number presents a dull and more flaky appearance on fracture, and is only available for conversion into malleable or wrought-iron by the puddling process; for in melting it passes, previous to complete fusion, through an intermediate pasty condition particularly favourable for its decarburisation in the puddling furnace, and with less loss of iron than if the metal were in a more perfectly fluid state.

165. In Staffordshire the grades number from No. 1 to No. 8, of which, as above, No. 1 is the greyest, No. 2 less grey, and so on to No. 5, where mottled iron commences; after which the amount of white iron in the pig continually increases between this number and No. 8, which is white iron, and in which all trace of grey has disappeared.

166. Pig-iron smelted entirely from ores (mine) and without any admixture of puddling-cinder or slag, is known as "*all-mine pig-iron*," whilst where slag or cinder has formed a very considerable proportion of the furnace charge, the product is then known as "*cinder-pig*," and such metal forms altogether an inferior class of pig-iron. *Glazed* or *blazed* pig is also an inferior, highly siliceous pig, often produced when a furnace is first blown in, owing to the excess of fuel then employed. The highly manganiferous pig-iron used extensively in the steel manufacture, and not classed above, is known as *Spiegel-eisen*, and a compound still richer in manganese than the last mentioned is called *ferromanganese*. (See p. 99.)

CHAPTER VI.

THE PRODUCTION OF PIG-IRON.

167. THE production of pig-iron from the various ores of iron comprises two stages. 1st. *The preparation of the iron ores for the blast furnace.* 2nd. *Smelting of the iron ores in the blast furnace.*

168. Owing to the comparatively small value of iron ores, they are not usually submitted to any complicated or expensive previous mechanical treatment for the separation of the gangue or earthy portions, before either their calcination or smelting, except in the case of special ores, such as the *titaniferous sands* of Mosie, Canada, where the sands are concentrated first by the separation of the more siliceous portions, then by dressing and washing them upon shaking tables, in a gentle current of water; but these sands, again, are not smelted for pig-iron, but are treated for the production of malleable iron direct in the American Bloomery Furnaces to be subsequently described.

169. The two stages noted above for the production of pig-iron from iron ores embrace two distinct classes of operations :

1st. The preparatory treatment of the ore or mine, as received from the miner, previous to its treatment in the blast furnace, and which includes :—

- a, The mechanical preparation of the ores ;
- b, The weathering of certain classes of ores ;
- c, The roasting, or calcination of the ore.

2nd. Smelting, or reduction in the blast furnace, whereby the metal is separated from its chemical combinations with oxygen, then carburised to pig-iron, and separated by fusion from the earthy constituents of the ore. In order to effect these changes it is necessary that the blast furnace be of considerable height, and that the pressure of blast be sufficient to pass freely through

the superincumbent mass of fuel and ore in the furnace ; further, the twyers through which the blast is delivered into the furnace must be laid horizontally, or not directed downwards into the bath of molten metal, for under the latter condition malleable iron would result, as in the Bloomery furnaces, instead of the pig-iron required to be produced in the blast furnace.

170. **Preparation of iron ores.**—In England it is not usual to submit iron ores to any preliminary mechanical treatment, previous either to their calcination or smelting ; except to break them up into fragments of a fairly uniform size, regulated according to the size of the furnace and the ease with which the ore is reduced. Thus, the ore and fluxes in the case of the large furnaces of the Cleveland district, are broken into lumps approximately of from four- to six-inch cubes ; in the hæmatite districts, again, the furnaces are smaller, and the materials are broken into cubes of two inches resembling road-metalling, whilst for the still smaller furnaces employed in Sweden the pieces are only about one-inch cubes.

171. Where machines are used for breaking up the ore, as in America, France, Belgium, and Germany, the more usual form employed is that of Blake's Stone-Crusher, in which the ore is broken by a hard oscillating jaw, moving to and from a corresponding hard fixed face ; or another method consists in passing the calcined materials between hard cast-iron rollers.

172. **Weathering of iron ores** is only necessary for such ores as contain pyrites or shale in considerable proportion ; in which case, instead of directly calcining, or in exceptional cases after calcination, the ores are exposed in heaps to the action of the atmosphere, whereby, under the joint action of atmospheric air and moisture, the sulphur is oxidised with the production of soluble sulphates which are dissolved out by the rains ; but it is obvious that this method is not applicable to the treatment of calcareous ores, since the soluble ferrous and cuprous sulphates formed by the

oxidation would be decomposed by the lime, with the formation of a sparingly soluble calcic sulphate, which largely escapes solution, and the separation of the oxides of the above mentioned metals ; and thus the deleterious elements, copper and sulphur, would both remain in the ore, although in different states of combination to those in which they occurred in the original ore. Also such calcareous ores cannot be subjected to any prolonged weathering *after* calcination, otherwise the ore would break up and fall into powder, owing to the slacking of the lime during the lixiviation for the solution of the soluble sulphates, and so be unfit for introduction into the blast furnace.

173. The process of weathering is continued upon suitable ores during three or four months ; and in exceptional cases, as with the pyritous siliceous hæmatites of Germany, the weathering after washing extends over one, two, or three years, with occasional lixiviation or washings during the whole period. Certain nodular argillaceous ironstones which are accompanied by shale and rock suffer oxidation on exposure to the atmosphere for a short time, whereby the shale and rock, which are not readily separated from the ore as it is first received from the mines, become easily separable. Again, certain spathose ores are converted by a limited exposure to the weather into brown hæmatite ; but in all these special cases it becomes necessary not to carry the operation of weathering too far, otherwise the ore falls to powder and becomes unfitted thereby for charging into the blast furnace.

174. The calcination or roasting of iron-ores has for its object the expulsion of water, carbonic anhydride (CO_2), sulphur, and volatile or other matters, which, under the influence of heat, or the combined action of heat and atmospheric air, are capable of volatilisation, and whereby the ore besides being freed from the above-mentioned constituents is also left in a more or less porous condition, more readily permeated and acted upon by the reducing gases of the blast furnace. Also

the partial oxidation during calcination converts (at least superficially) the *ferrous* compounds—such as are contained in spathic ores, and which readily combine with and form fusible compounds with silica in the blast furnace—into *ferric* oxide which does not so readily combine with silica; and the calcination is conducive, therefore, to a saving of iron in the blast furnace, since the slags of ferrous silicate produced by the union of ferrous oxide with silica are difficult of reduction, and the iron in them is largely lost; but ferric oxide also consumes a little more fuel in its reduction than does ferrous oxide. Roasting has the effect also of decomposing to a large extent such metallic sulphides as pyrites, which are first oxidised and then, if the temperature be sufficiently high, the whole of the sulphur is eliminated, the metallic oxide alone remaining in the roasted mass. The changes produced by calcination are indicated in the following

ANALYSIS* OF THE RAW AND CALCINED CLEVELAND STONE.

	Cleveland ore or stone, uncalcined.	Cleveland stone, after calcination.
Ferric oxide (Fe_2O_3)	2.60	66.25
Ferrous oxide (FeO)	38.06	—
Manganous oxide (MnO)	0.74	—
Manganic oxide (Mn_2O_3)	—	0.65
Alumina (Al_2O_3)	5.92	7.72
Lime (CaO)	7.77	6.46
Magnesia (MgO)	4.16	4.78
Potash (K_2O)	trace	0.02
Carbonic anhydride (CO_2)	22.00	—
Water (OH_2)	4.45	—
Silica (SiO_2)	10.36	11.87
Sulphur (S)	0.14	—
Phosphoric anhydride (P_2O_5)	1.07	1.13
Sulphuric „ (SO_3)	—	0.90
	97.27	99.78

* J. T. Bell: "Chemical Phenomena of the Blast Furnace."

175. When forge- or mill-cinder is to be added to the blast furnace charge as an iron-producing material in the production of cinder-pig, it is usual to first roast the cinder in an oxidising atmosphere, since such cinders or slags are essentially ferrous silicates containing from 40 to 60 per cent. of iron, and in the case of forge-cinder it contains also nearly the whole of the phosphorus and most of the sulphur present in the original pig-iron from the working of which the cinder has been produced; but the mill-cinder always contains a smaller proportion of these elements. Ferrous silicates when heated in an oxidising atmosphere are largely decomposed with the separation of the iron, in the form of ferric and magnetic oxides; whilst any sulphur is first oxidised, and either collects on the surface of the pile as ferrous sulphate, which is dissolved out by lixiviation, or, if the temperature be high enough, the ferrous sulphate is decomposed, and the whole of the sulphur eliminated. (See also "bull-dog" and "bull-dog slag," p. 56.)

176. Ores containing free silica, readily fusible silicates, or manganese compounds in notable proportions, have a tendency to clot during calcination if the temperature be allowed to rise too high, and thus frustrate one of the objects of the calcination, viz., the production of a porous mass permeable by the reducing gases of the blast furnace; but with calcareous or compact ores rich in iron a more prolonged and a higher temperature of calcination is permissible, there being but little tendency to clot or to become matted. The degree to which calcination is carried is influenced by the grade of pig-iron to be produced; thus, for the production of forge qualities of pig-iron the calcination is usually stronger and more prolonged than if foundry pig is to be the yield of the blast furnace.

177. The *loss of weight* during the process of calcination varies with different ores, for, whilst the Blackband iron-ores of Scotland—on account of the large proportion of bituminous matter which they contain—will lose by roasting, in some cases as much as 50 per cent. of their

weight, the Welsh argillaceous ores suffer a loss of from 25 to 30 per cent., or an average of about 27 per cent. The brown hæmatites lose some 12 or 14 per cent., and the red hæmatites only about 6 per cent., of their weight; so that it is not the practice in the hæmatite districts of England to subject such ores to any preliminary calcination, since water is the chief volatile ingredient, and this is expelled by the heat of the ascending gases as the ore lies in the upper zones of the furnace, and before it descends to the hotter and reducing zones. The only preliminary treatment to which the English hæmatites are subjected, before being charged along with fuel and flux into the blast furnace, is, as already mentioned, to break up the ore into comparatively uniform blocks of some two inches square; but even this practice is in numerous iron-works invariably neglected, the ore being charged direct into the blast furnace exactly as it is received from the mine, without any mechanical preparation whatever.

178. Roasting or calcination of iron ores is effected in *clamps* or *open heaps*, *between closed walls*, or in variously designed *kilns*, but in all of these it is necessary to observe a careful regulation of the temperature, so that the ores may not be softened, partially fused, or clotted together into compact masses impervious to the ascending gases in the subsequent smelting operation. With such ores as the Blackbands, containing much carbonaceous matters, care should be exercised that the temperature does not rise sufficiently high to effect a partial reduction of the metal in the ore.

179. Roasting or calcination in open heaps, as carried on in South Wales, Staffordshire, &c., consists in placing upon a piece of level ground a layer or bed of coal several inches in thickness, upon which are put ore and fuel in alternatè layers, until the pile so formed reaches to a height of from four to five feet. The proportion of ore to fuel in the several layers is made to increase from the bottom towards the top of the pile. In the Hartz

districts the first layer on the ground consists of a bed of slag, upon which is placed a layer of iron ore, and then alternate layers of fuel and ore, until the whole forms a truncated pyramid of some nine feet in height, with a base measuring about sixty feet square. According to either the English or Continental method, the conduct of the operation is the same, the fire being first lighted at the base of the pile just as in charcoal burning; and, as the process advances, if any portion of the surface indicates that the combustion is proceeding too rapidly, or that the calcination is too active, then such part or parts are damped down with small ore, so that the process in those directions is checked. The period of calcination thus continues until the whole of the coal in the pile has been consumed.

180. In the Hartz the ores to be treated are calcareous, and the process has a duration of from eight to fourteen days; and for the calcination of each cubic foot of such ores about one-third of a cubic foot of small coal is consumed.

181. Blackband ores frequently contain from 25 to 30 per cent. of combustible matters, and these or such others as contain much bituminous matter are usually roasted without any further addition of fuel or carbonaceous material.

182. Ores containing much carbonaceous matters, sulphur, or other combustible substances, are treated in longer heaps, with less width at the base, than those above described, whilst the height of the pile rarely exceeds about three feet; such heaps are preferable for the roasting of these classes of ores, since they do not attain to so high a temperature as the larger heaps, and the ore is not, therefore, so liable to become fused together. Further, also, this class of ores requires to be calcined in larger masses than is the case with argillaceous and other ores free from combustible matters; but other ores, such as those of Westphalia, which are less rich in carbonaceous matters, are usually treated in large heaps of from 20 to 30 feet in width, from 15 to 20 feet in height, and of various lengths, in which

the calcination is continued from two to three months before it is completed.

183. Although the various methods of conducting the calcination of iron-ores in heaps are essentially the same, yet numerous devices are adopted in different localities for the better regulation of the heat throughout the mass ; as by modifications in the dimensions of the pile as already noted ; also by building together the larger pieces of ore so as to form draught-holes communicating with the fuel placed in the interior of the heap, and placing around these draught-holes the smaller ore, whereby, when the pile is ignited, the direction of the flame and heat can be controlled by damping down the surface or opening out these draught-holes as required. With the same object, it is a practice in the Westphalian works to form draught-holes between the sides of the pile and other passages in the interior of the pile ; these passages are first filled with wood, and the pile is constructed by placing the larger lumps of ore around the exterior of the pile, so as to form an outer wall of ore, whilst the smaller ore is placed along the sides of the draught-holes, with the larger pieces more distant from the heated currents passing through these passages. In this manner is erected a heap of upwards of 100 feet in length, which burns for one month, the combustion being maintained through the draught-holes formed throughout the whole mass of the pile ; and the progress of the calcination is checked as before, by throwing a portion of the smaller ore upon such portions of the pile as indicate a too rapid rise in temperature.

184. In *pyritous ores*, the pyrites usually occur in laminæ, plates or nodules, arranged along the planes of stratification of the ore, and since the gases passing through the pile are largely of a reducing character, the sulphur does not suffer complete oxidation. Grundman* therefore recommends, in order to facilitate the elimination of sulphur from such ores by the process of

* Grundman : "Entschwefel der Eisenerze."

volatilisation, that the lumps or blocks of ore should be placed with their planes of stratification vertical, and that the surface of such piles be covered with small ore to condense and collect the sulphur.

185. The great disadvantage of calcining or roasting in heaps is the comparatively large consumption of fuel which the process entails, amounting in the South Wales and Staffordshire districts to about $2\frac{1}{2}$ cwts. of coal, consisting of two cwts. of small and half cwt. of large coal to the ton of ore. There is also a difficulty in regulating the temperature throughout the pile, for whilst the ore in the interior of a pile is often clotted or partially fused (especially when spathic carbonates or pyritous ores are under treatment), the other portions of the pile are frequently insufficiently or incompletely roasted, and this irregularity is further aggravated when much carbonaceous matters or pyrites are present, since the combustion of these substances locally intensifies the heat, and so tends to clot the ore.

186. Calcination between closed walls is pursued in the Hartz, where clay ironstone is treated with charcoal dust or breeze as the fuel. The walls of the pile are from 6 to 12 feet in height built around three sides of a rectangular area, the floor of which is usually made to slope slightly towards the front or open side. In the enclosing walls are constructed two rows of draught-holes, each of about four inches in diameter, the lower row being placed near the ground level, whilst the second row is about three feet higher up. These draught-holes are in communication with chimneys in the interior of the pile built up of the larger pieces of ore, and these chimneys also communicate with air-passages left in the base of the pile, or formed by pieces of timber, and so the circulation of air is effected through the draught- or vent-holes and the chimneys. The conduct of the process is otherwise like that described for the calcination of iron-ores in open heaps, but the temperature and draughts are here more under control, and there is a less expenditure of fuel,

with more perfect calcination of the ore, than occurs in open heaps.

187. Roasting or calcination in kilns is more economical in both fuel and labour, the temperature is also more under control, and the calcination of the ore is more uniform than when the process is performed in open heaps. The operation of calcining in kilns is also continuous, the kilns being built so that as the calcined ore is withdrawn from the bottom of the kiln, fresh raw ironstone and fuel are being added at the top. The kilns generally employed on the Continent are cylindrical or conical in vertical section, and are either circular or rectangular with the corners well rounded off in horizontal section, whilst the size varies with the nature of the ore to be treated ; thus, whilst the circular kilns employed in calcining large ore are only from 9 to 11 feet in height, those built for the treatment of small ore are rectangular in horizontal section, and measure as much as 80 feet in length by 35 feet in width. Coal dust is the fuel employed in Styria for the calcination in kilns of spathic iron-stone with brown hæmatite, the coal being interstratified with the ore in the charge ; but in other districts the kilns are arranged for burning the fuel on separate grates built at the side of the kiln, from which grates the heated products of combustion are conveyed through the mass of ore in the kiln ; but in other examples the heat is obtained by the combustion within the kiln of the waste gases of the blast furnaces.

188. In the first-mentioned circular or rectangular type of kiln, a layer of fuel is first placed upon the bottom or bed of the kiln, and upon this are distributed alternate layers of ore and fuel until the kiln is quite filled. The fuel at the bottom is then ignited, and the air for its combustion is also admitted at the bottom of the kiln, the rate of combustion being regulated by the draught produced through a large number of holes in the brickwork around the kiln, more holes being opened as required for the calcination of the smaller and finer ore. As the process goes on the

charge sinks, is withdrawn by raking it down an inclined plane at the bottom of the kiln, and more ore and fuel are added at the top to supply the place of that withdrawn.

189. In the Cleveland district, *Gjers' kilns* (Fig. 7) are frequently employed; these are circular in section, and built of iron plates lined with 14 inches of brickwork. Such

kilns are of about 33 feet in height and 24 feet in diameter at the widest part, having a capacity of about 8,000 cubic feet, holding, therefore, about 350 tons of ore and fuel; but they are also constructed of twice this capacity. The *Gjers' kiln* resembles in appearance a low blast furnace, with a conical lower portion tapering towards the bottom; and the whole is carried upon a cast-iron ring resting upon short cast-

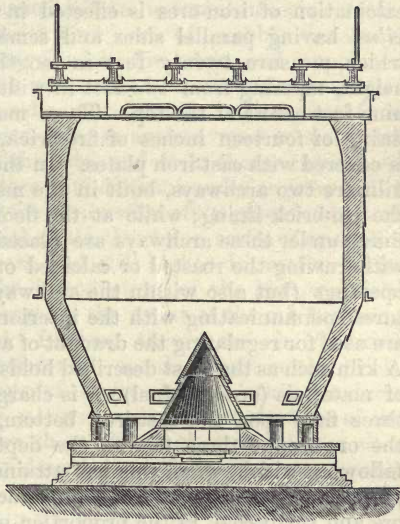

Fig. 7.—Vertical Section of Gjers' Calcining Kiln.

iron columns, so as to leave a clear space between the bottom of the kiln and the ground of about 30 inches. In the centre of the kiln and resting upon the ground is fixed a cast-iron cone with its apex upwards; this serves to direct outwards the descending roasted ore, which is then raked outwards between the columns carrying the kiln, whilst fresh ore and small coal are constantly being added at the top, to replace the materials withdrawn at the bottom. Around the body

of the kiln, and near the bottom of the same, are openings usually closed by doors, but which serve for the admission of air as required for the process, and also for the introduction of the bars or other tools as may be necessary if the ore becomes softened or clotted from excess of heat.

190. At Dowlais and other works of South Wales, the calcination of iron-ores is effected in *massive stonework kilns*, having parallel sides and semicircular ends, and which measure twenty feet in length, eighteen feet in height, tapering from two feet in width at the bottom to nine feet across at the top. These masonry kilns have a lining of fourteen inches of fire-brick, whilst the bottom is covered with cast-iron plates. In the front side of each kiln are two archways, built in the masonry and open to the fire-brick lining; while at the floor level through the lining under these archways are placed two openings for withdrawing the roasted or calcined ore, and above these openings (but also within the archway) are several apertures communicating with the interior of the kiln which are used for regulating the draught of air through the kiln. A kiln such as that just described holds about seventy tons of materials (ore and fuel); it is charged by first making three fires upon the cast-iron bottom, and then placing the ore around these fires to the depth of a few inches, following which, when this has attained to a red heat, is placed another layer of some nine inches in thickness of ore and small coal, in the proportion of about one cwt. of coal to one ton of ore; this last layer, after attaining to redness, is, in its turn, again covered with a like stratum of a mixture of coal and ore, and so on until the kiln is quite filled to the top, by which time the ore first introduced is ready for withdrawal, an operation effected through the openings at the floor level already mentioned. Fresh additions of ore and fuel are then continually added at the top of the kiln to replace that withdrawn from the bottom, and in this manner the calcination proceeds uninterruptedly in the upper zones of the kiln, whilst the roasted ore is at the same time being withdrawn

from the bottom, the descent of the charge from top to bottom of the kiln occupying from three to four days.

191. In the *Swedish calcining kiln* as adapted for the utilisation of the waste gases of the blast furnace, the kiln is built of a circular section, slightly conical, and about eighteen feet in height, with a mean diameter of six feet. It is formed of an external massive structure either of brickwork or of rubble masonry, the whole being lined with fire-brick and supported by bands of wrought-iron around its circumference, after the manner of an ordinary brick-kiln. The gases from the throat of the blast-furnace are conveyed to a circular main at the base of the kiln, and from thence introduced into the kiln by sixteen equi-distant nozzles or jets; whilst the necessary air for the combustion of the gases is admitted a little higher up in the kiln through a series of apertures controlled by dampers, and still higher is another series of openings for the introduction of the bars required to break up the charge in the event of the ore becoming agglomerated; and, further, there are in addition numerous other horizontal openings left in the brickwork, for the escape of moisture and other products expelled during the calcination; whilst at the base of the kiln are openings for the withdrawal of the charge after the manner already described. These kilns are capable of roasting about twenty-five tons of magnetite and schistose hæmatite in the twenty-four hours.

192. The small gas-kilns of *Fillafer's* patent, as employed in Styria for calcining spathic iron ores, are heated by the waste gases taken from the throat of the small blast furnaces there employed in the smelting of the same ores. These kilns are rectangular chambers of about two cubic mètres (75·6 cubic feet) in capacity, and are built in rows back to back, each kiln measuring 1·422 mètres (4 feet 8 inches) in length, 2·657 mètres (8 feet 9 inches) in height, and 0·526 mètres (1 foot 8 inches) in breadth. The waste gases from the blast furnace are delivered into a horizontal main, from which

they ascend through vertical flues in the lower part of the brickwork of the kiln, into two long horizontal chambers, built one on each side of the calcining chamber, and from whence the gas is delivered for combustion above the level of the grate-bars, through seven slits or jets along each side of the furnace. The bottom of the kiln is formed by a movable grating of bars, upon which the ore charged in at the top rests, whilst the roasted ore is withdrawn into a cooling chamber below, by removing one or more of the grate bars as required. In such kilns about eighty cwts. of ore in lumps are roasted during twenty-four hours, the kiln being twice filled during this interval, and the roasting is attended with a loss of about 30 per cent. upon the weight of the raw ore. It is difficult to treat small ore in these kilns, since it lies too closely, and stops the draught through the bars which is necessary for the combustion of the blast furnace gases; and accordingly, if small ore be treated, the kilns do not roast more than 50 per cent. of the proportion yielded when large ore is operated upon.

193. **Smelting of iron-ores in the blast furnace.**—The impure oxides and carbonates of iron constitute the only ores from which pig-iron is produced on the large scale; and since ferrous carbonates are reduced to the state of ferric oxide (Fe_2O_3) either during calcination or before the ore reaches the zone of reduction in its passage through the blast furnace, it thus follows, that the chemical reactions which occur in the smelting of iron are very simple, involving only the reduction of ferric oxide, which, as already noted, can be effected at a red heat by carbon, hydrogen, carbonic oxide, &c.; the product so obtained from the blast furnace would, however, be a heterogeneous mass or metallic sponge of malleable iron, enclosing the refractory gangue or earthy matters accompanying the ore, together with a slag of ferrous silicate if the ore be very rich. The mechanically mixed impurities, slag or scoriæ, just enumerated, prevent the reduced metallic particles from being brought into

contact, and so render it impossible to consolidate the metal by compression under the hammer or by other means employed for the production of a solid mass ; and thus for the production of pig-iron the product so obtained requires to be combined in the blast furnace with a proportion of carbon in the manner to be immediately described, whereby the metal becomes more fusible, and so separable by fusion from the gangue accompanying the ore. And further, that the loss of iron arising from the formation of rich ferrous silicates may be largely prevented, there is added to the furnace a flux which, by combining with the siliceous matters of the ore, prevents the formation of these silicates (which are only reducible with difficulty), and leaves the ferric oxide in a state to be readily reduced by the carbonic oxide in the furnace, or by the carbon of the fuel. Thus if the whole of the iron is to be extracted from rich ores of iron it is necessary to employ a temperature above redness, and to add a flux which shall form a fusible slag with the gangue of the ore, to the exclusion of rich ferrous silicates ; for beyond the direct loss of iron in such silicates, their presence also prevents the union of the reduced iron with the carbon necessary for the production of pig-iron.

194. The gangue accompanying iron-ores is usually either of a quartzose or of an argillaceous character, and is infusible at the highest temperature of the blast furnace ; but by the addition of lime to the charge comparatively fusible slags of the silicates of lime and alumina result, but even these slags require a much higher temperature for their fusion than the ferrous silicates just spoken of. At the high temperature thus necessarily maintained in the blast furnace, the *reduced iron combines with an amount of carbon derived from the incandescent fuel in the furnace*, or from the finely-divided carbon with which the mass of ore in the furnace is impregnated, and pig-iron results.

195. When the blast-furnace is in regular work, or "in blast" as it is technically called, it is necessary to keep

it filled to the top or throat with alternate layers of fuel, ore, and flux, fresh materials being added to the top as the charge works down. At the same time, the blast entering through the twyers near the bottom of the furnace is constantly and uninterruptedly supplied throughout the whole campaign, except during the brief intervals in which it may be shut off for tapping the furnace, or for opening the furnace top for the introduction of the charge. The blast should be delivered at a sufficiently high pressure to pass freely through the whole contents, and this is effected, according to the size of the furnace, by a pressure of from 3 to 6 lbs. per square inch in furnaces employing coke as the fuel, or from $1\frac{1}{2}$ to 2 lbs. in those consuming charcoal.

196. The *action of the blast furnace* commences immediately the blast from the twyers meets the incandescent fuel (coke or charcoal), so that active combustion prevails, and the oxygen of the blast is consumed within a small distance of the twyers, attended by the production of carbonic anhydride (CO_2), and by the evolution of intense heat; but the carbonic anhydride so produced ascends towards the throat of the furnace through the superincumbent mass of incandescent fuel and other substances, and becomes reduced within a very short distance upwards to the condition of carbonic oxide (CO)—thus, $\text{CO}_2 + \text{C} = 2 \text{CO}$. Each volume of carbonic anhydride yields two volumes of carbonic oxide, the change being attended at the same time by a corresponding absorption of heat, so that the zone of maximum intensity of heat corresponds to the area where carbonic anhydride is first produced, and is thus confined to a very limited area in the neighbourhood of the twyers. The *carbonic oxide* produced in the above manner then *becomes the principal and active reducing agent of the blast furnace*, and it ascends along with the heated nitrogen introduced with the blast of atmospheric air, together with smaller quantities of other gases, as hydrogen, &c., through the furnace, meeting in

its ascent the highly heated ore and fluxes. The ore is moreover in a porous condition from its previous calcination, or from its heating in the upper portions of the furnace, and is thus in a state highly favourable to its permeation by the current of ascending reducing gases, and therefore to the reduction of the iron. The reduction of the iron is largely effected by the carbonic oxide, which is converted thereby into carbonic anhydride. Thus $\text{Fe}_2\text{O}_3 + 3 \text{CO} = 3 \text{CO}_2 + 2 \text{Fe}$, whilst possibly a small proportion of the iron may also be reduced from the ferric oxide (Fe_2O_3) by the direct action of carbon, at the high temperature of the furnace. The nitrogen and other gases which do not act as reducing agents assist by their sensible heat to raise the temperature of the materials in the upper part of the furnace; and hence the higher the furnace the more perfectly is the heat absorbed from the ascending gaseous current, with a corresponding decrease in the temperature of the gases escaping from the tunnel head of the furnace, although the escaping gases from both the high and the low furnaces may contain the same percentage of combustible gas, and yield as much heat upon their subsequent combustion.

197. The iron thus reduced from its ores by carbonic oxide or other reducing agent is accompanied in its descent towards the furnace hearth by the slags resulting from the union of the fluxes and the earthy matters of the ore; and during the descent of the iron it is further carburised by contact with the heated carbon, and its carburisation may also, to a lesser degree, be effected by the decomposition of carbonic oxide, hydrocarbons, or cyanogen compounds (present in the furnace) by the reduced iron. Thus, the fusible compound of iron with carbon and other impurities constituting pig-iron collects in the hearth of the furnace, above which, in virtue of its lower specific gravity, floats the fusible slag, protecting the metal in the hearth from the decarburising influence of the blast which enters above it.

198. The changes and reactions under which, in the neighbourhood of the twyers, the combustion of carbon by the oxygen of the blast is effected, with the production of carbonic anhydride, are followed by the almost immediate reduction of the carbonic anhydride to the condition of carbonic oxide by the great mass of heated carbon through which the gas passes, and followed again by the re-oxidation of the carbonic oxide so formed into carbonic anhydride, with the reduction of ferric oxide and the separation of metallic iron. The carbonic anhydride is, in its turn, again reduced to carbonic oxide by contact with incandescent carbon as before; and so this cycle of changes by which carbonic anhydride and carbonic oxide are alternately produced, with the reduction at each change of a proportion of the iron from its ores, is repeated in rapid alternations as the gases ascend through the furnace; and these reactions are continued so long as the temperature remains sufficiently high to effect the changes. It is thus obvious that the gases taken from all vertical sections of the furnace above the twyers will yield on analysis both carbonic anhydride and carbonic oxide, but that the proportion of the former to the latter will increase towards the top of the furnace, owing to the lower temperature there prevailing, and the consequently less active reaction going on between the carbonic anhydride and the carbon of the fuel; whilst the reduction of ferric oxide (Fe_2O_3) by carbonic oxide is also continued at a somewhat lower temperature than that required for the reaction of carbon upon carbonic anhydride necessary for the reduction of the latter to the state of carbonic oxide. The amount of carbonic anhydride is further increased in the upper zones of the furnace by the burning of the raw limestone (CaCO_3) introduced as flux. Notwithstanding the tendency of the per-centage of carbonic anhydride in the furnace gases to increase towards the throat of the furnace, yet the escaping gases contain a very large proportion of carbonic oxide, as is manifested by the appearance of its characteristic lambent

flame, when the top of the furnace is temporarily opened for the introduction of the charge, &c. Owing to the large proportion of combustible gases which thus reach the throat of the furnace, it is now the usual practice to collect the waste gases which would otherwise escape from the blast furnace and utilise them by burning them for the heating of the blast, raising of steam, calcination of ore, &c.

199. In the above description of the action of the blast, it has been assumed that the first effect of the entrance of the blast into the furnace is the combustion of the fuel and the production of carbonic anhydride in the neighbourhood of the twyers; but Mr. I. L. Bell, in his "Chemical Phenomena of Iron Smelting," supports the opinion of Professor Tunner that carbonic oxide, and not carbonic anhydride, is directly formed by the combustion of the fuel near the twyers, and that the heat so formed, although less than it would be if carbonic anhydride was produced, would yet be sufficient to melt the reduced iron and slags, and to account for all the phenomena of the furnace. The same author likewise considers it probable that the carburisation of the reduced metal, instead of being the result of the direct contact of the heated metal with the fuel, may be effected by the finely-deposited carbon with which the ore becomes impregnated in the blast furnace, as the result of a decomposition of carbonic anhydride and carbonic oxide in some manner during their passage through the furnace.

200. As already noticed, the calcination of iron ores does not affect the quantity of *phosphorus in the ore*, and therefore the whole of the phosphorus in the ironstone is introduced into the blast furnace; and it is found that in smelting iron-ores containing phosphorus practically the whole of the latter element, whether derived from the ore, fuel, or fluxes, finds its way into the pig-iron produced in the blast furnace, unless a considerable proportion of ferrous oxide be allowed to escape reduction by passing into the slag, when a considerable proportion

of the phosphorus will also be found in the slag, and the resulting pig-iron will be comparatively free from this element; and so *vice versâ*, if the slag be free from ferrous oxide it will also contain but little phosphorus, whilst the pig-iron will be more or less phosphoric if phosphoric ores be constituents of the furnace charge. Thus the conditions of the blast furnace most favourable for the perfect reduction of iron, with little loss of metal in the slags, are also the conditions consonant with the reduction of phosphorus and the production of a phosphoric pig-iron; and in the normal smelting of the Cleveland ores about one-tenth of the phosphorus in the ore passes into the slag,* whilst the remainder is found wholly in the pig-iron produced.

201. Any *manganese* occurring in the iron-ores is also, like phosphorus, to be found partly in the resulting pig-iron and partly also in the blast furnace slag, but the production of spiegeleisen, or manganiferous pig-iron, is facilitated by a hotter blast and a higher temperature in the furnace hearth.

202. The *sulphur* in the mine or ore is largely expelled during calcination, but such as escapes expulsion under this treatment, and so enters with the iron-producing materials into the blast furnace, occurs along with that accompanying the fuel or fluxes, either in the resulting pig-iron or in the slags, according as the slag is calcareous or siliceous in character. If lime be in excess in the furnace then there is a marked tendency of the sulphur to pass into the slag, possibly as calcic sulphide; but if on the contrary the slag be more siliceous, the silica being present in sufficient quantity to form by combination with the lime and alumina present in the furnace charge a readily fusible vitreous slag, then a larger proportion of the sulphur will be found in the pig-iron yielded by the furnace. Hence, *white iron*, which is produced at a lower temperature than grey iron, and is accompanied by a fusible siliceous slag, is usually *more sulphurous* than

* I. L. Bell: "Chemical Phenomena of Iron Smelting."

grey iron, so that a high temperature with a liberal use of lime are the conditions favourable to the make of grey pig and the elimination of sulphur from the iron, whilst a proportionately larger per-centage of sulphur will occur in the slag than is found with the lower temperature and more siliceous slag accompanying the make of white iron. The proportion of lime does not, however, appear to affect the amount of phosphorus in the pig-iron.

203. A comparatively high temperature being necessary for the reduction of silicon, it is found, as would be expected, that the higher the temperature of the furnace the richer in silicon is the resulting pig-iron, so that the lower grades or numbers of pig-iron, which are always produced at the higher temperatures, are more siliceous than the higher numbers. Too high a temperature of the furnace is sometimes productive of a metal somewhat leaden in aspect, exhibiting however a grey fracture, but with very small crystals; such pig is known as *glazed* or *glazy pig*, and it yields weak, inferior castings when it is used in the foundry, whilst it melts in the puddling furnace like water, destroying the fettling of the furnace long before the iron affords any indication of coming to nature. Glazy pig-iron is therefore almost worthless either for foundry or forge use, and the remedy for a furnace working upon such metal is either to lower the temperature of the blast, which is the most convenient method, or to attain the same end by increasing the burden of the furnace.

204. Ferromanganese is a variety of pig-iron containing from 20 to 60 or 80 per cent. of manganese, which has during recent years come into extensive request in the manufacture of soft or mild steel. It is a hard, crystalline body, but, unlike spiegeleisen, its fracture does not present the large cleavage planes so characteristic of the latter. The name spiegeleisen is now generally reserved for the varieties of pig-iron which although rich in manganese do not contain more than 20 per cent. of that metal; while the name of ferromanganese is applied

to those varieties of pig-iron containing upwards of 20 per cent. of manganese. Ferromanganese though, until recently produced almost wholly upon the Continent from Spanish or Sardinian ores containing from 10 to 40 per cent. of manganese, has now become an article of regular production in both England and France. But its production requires not only suitable ores but also a blast of the highest possible temperature that can be produced in fire-brick stoves, while the consumption of fuel is exceedingly high, amounting, when the metal contains 80 per cent. of manganese, to no less than three and a-half tons of coke per ton of metal made; and the yield of the blast furnace falls to between twelve and twenty tons of ferromanganese per day, in furnaces which would yield from fifty to sixty tons of ordinary pig-iron per day. Of the manganese present in the furnace charge, from 60 to 70 per cent. only is reduced and passes into the pig-iron, while the remainder passes largely into the slag, but a portion also is most probably volatilised at the high temperature employed. Ferromanganese can be obtained containing about 85 per cent. of manganese, but while a ferromanganese containing 80 per cent. of manganese is quoted at £20 per ton, spiegeleisen containing 20 per cent. is worth only about £5 10s.

205. Efforts have from time to time been made to determine the **zones or areas within the furnace** in which the several chemical decompositions and changes previously described are confined, as also the temperatures of these several limits. But such efforts are necessarily unsatisfactory, owing to the varying products which are found at the same depth from the throat, under the varying conditions of the furnace on different occasions; such variations arising from the somewhat complex nature of the action of the blast furnace, and the irregularities introduced into its working by small differences in the quality of the ore, fuel, and fluxes at the various intervals; also from the want of care in charging, and from alterations in the temperature of the blast; whilst even atmospheric

changes have an effect upon the regular working of the blast furnace, the latter alone being sufficient, according to Mr. Bell, to effect a rise or fall of a number in the quality of the pig-iron, and to make a difference of fully 5 per cent. in the consumption of fuel in the furnace per ton of metal produced. Moreover, as the cycle of changes whereby the carbonic anhydride produced upon the combustion of the carbon of the fuel by the oxygen of the blast is almost immediately converted into carbonic oxide, which in turn by its reaction upon ferric oxide becomes again oxidised to carbonic anhydride, is repeated as the gases ascend through the furnace, so long as the temperature remains at or above dull redness, it is obvious that anything which tends to elevate the temperature will continue these operations to a higher point in the furnace, and so it becomes difficult to indicate more than the order in which the several areas of reaction follow, from the throat to the hearth of the furnace. Mr. I. L. Bell* has endeavoured to map in a general way the conditions of the furnace and of its charge, at various depths from the hearth to the throat. Commencing from the throat of the furnace, there is (Fig. 8) an upper zone, *a*, in which are lodged the materials just charged into the furnace, and where they are being heated by the ascending gases; but within twenty feet from the throat the charge has attained to a *dull red heat*, and the ore is in a condition, therefore, for reduction by carbonic oxide with the production of a spongy metallic mass. Descending now to the zone, *b*, the furnace is at a *red heat*, and the carbonic anhydride is being

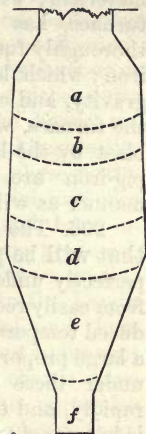

Fig. 8.—Diagram indicating the several Zones of Action in the Blast furnace.

* Proceedings of Institute of Civil Engineers, 1872.

expelled from the limestone; whilst in the area, *c*, a *full red heat* is attained, and the reduced spongy metal in its descent begins to absorb or combine with carbon from the incandescent fuel, &c., with which it comes into contact, in the manner already described. This combination or absorption of carbon continues through the next zone, *d*, which is at a *bright red heat*, and where it is probable also that the reduction of sulphur, silicon, phosphorus, &c., of the charge, and its combination with the iron, is effected; in the zone, *e*, constituting the boshes of the furnace, the temperature has reached a *very bright redness*, and is sufficient to effect the combination and fusion of the slag-producing materials; whilst the lowest zone, *f*, or hearth of the furnace, has attained a *white heat*, and the slags are thoroughly fused, and separate accordingly from the pig-iron; which latter sinks in virtue of its greater specific gravity, and collects as the lowest layer on the bottom of the furnace, where it is protected from the action of the blast by the layer of fluid slag above it. The slag and pig-iron are tapped out at such times and in the manner as will subsequently be described (p. 129).

206. The grade or quality number of the pig-iron that will be produced from a given blast furnace is not perfectly under control, but generally the iron produced from easily reducible ores, from furnaces working at a reduced temperature and with heavy burdens—that is, with a large proportion of ore to fuel—will be white iron; since under these conditions the charge works down more rapidly, and the period during which the reduced metal is in contact with the incandescent carbonaceous matters is reduced to a minimum, and the degree of carburisation of the pig-iron is accordingly at its lowest point. But with an increased temperature in the furnace, and the charging of lighter burdens—that is, where a larger proportion of fuel to ore is employed—then the pig-iron is usually grey and more siliceous than that made under the former conditions. Hence, if an *increased make* is to

be obtained from the same furnace whilst maintaining the quality of the pig-iron, the other conditions of ore and charging remaining the same, it becomes necessary to increase the size of the furnace. If the make be increased by harder driving (heavier burdening) of the furnace, other conditions remaining the same, then the quality of the pig-iron is deteriorated, usually turning the make into white iron, with the production at the same time of a scouring slag of ferrous silicate.

207. The nature and quality of the slag produced in the furnace has also an influence upon the quality of the metal produced, in the manner to be described when speaking of furnace slags (p. 109).

208. Fluxes, slags, fuel, &c., of the blast furnace.—The gangue or earthy matters of the ironstone, consisting for the most part of quartz (silica), clay (aluminous silicates), or of calcic carbonate, together with the earthy matters or ashes of the fuel, are any of them, when alone, either quite infusible or fusible only with difficulty; and hence, unless some other body is added capable of producing readily fusible compounds by combination with them, these earthy matters exercise by their presence a prejudicial influence upon the working of the blast furnace, and have an injurious effect upon the quality of the pig-iron produced. For these earthy bodies unless converted into a fusible slag descend in an imperfectly fused state to the hearth of the furnace, along with the reduced metal, and there remain more or less mixed with the same; but to prevent this, it is the practice to add to the furnace charge some substance which shall act as a *flux* to the particular earthy impurity accompanying the ore. The object, then, in the selection and addition of suitable materials as fluxes, is to add only such substances as, with the least possible addition to the furnace charge of any material not containing iron, will produce a readily fusible slag with the gangue of the ore. For this purpose it is desirable, as far as possible, to effect the result by the addition or mixing together of iron ores, in which the gangue

of the one will act as a flux to the other, and so produce the desired slag; thus, for instance, by the judicious mixing of *siliceous* and *calcareous* hæmatites, or by the addition of *argillaceous* ores to such a mixture in the required proportions, the necessary slag is produced, without the addition of non-ferriferous materials. In some of the red hæmatites of Sweden, &c., the ore is accompanied by a sufficient quantity of calcareous matters to yield the necessary flux without any further addition of fluxing materials to the charge; such ores are accordingly very economical in fuel, and are known as "self-going" or "self-fluxing."

209. Further, it is desirable that the slag in the blast furnace, whether produced by the mixture of ores as above, or by the addition of an independent flux, shall have such a composition and be present in sufficient quantity as to partially purify the pig-iron, by taking up as much as possible of the sulphur derived from the fuel charged into the blast furnace along with the ore; and with this object a larger proportion of flux is always added than would be necessary for the production only of the most fusible slag.

210. The *nature and quantity of the flux* depends accordingly upon the character and composition of the gangue accompanying the ore; thus, with a gangue containing free silica or a siliceous mineral, *limestone* is the flux usually employed; since, if such an ore be treated in the blast furnace with fuel only without the addition of any flux, the silica which is infusible when alone, would, on passing through the zone of most intense heat in the neighbourhood of the tuyers, combine with ferrous oxide from the ore, producing thereby a fusible basic ferrous silicate, the iron in which would thus escape reduction in the furnace, and the yield or make of pig-iron be proportionately reduced. But by the judicious addition of limestone with such ores, as the charge descends through the furnace the limestone is first converted into caustic lime, and then combines with the silica and alumina

of the ore, producing a fusible double silicate of lime and alumina, to the practical exclusion of iron from the slag. In the case just noted of an ore with a quartzose or siliceous gangue, such as the hæmatite ores of Lancashire Cumberland, &c., it is usual to add both lime and argillaceous matters to the furnace, the last mentioned being in the form of an iron-ore such as that imported from Belfast, which contains upwards of 30 per cent. of alumina, with 30 per cent. of ferric oxide, and only about 10 per cent. of silica. In this way iron-producing materials in which the earthy ingredients mutually act as fluxes to one another are introduced into the blast furnace. Bauxite, a mineral containing some 57 per cent. of alumina and 25 per cent. of ferric oxide, is also sometimes used as the flux in the working of siliceous ores.

211. If the gangue be of the practically infusible, argillaceous, or aluminous character, which in the blast furnace readily combines with ferrous oxide, with the production thereby of fusible double silicates of alumina and iron, but attended with an equivalent loss of iron, then, as with the siliceous gangue just noted, by the addition of limestone the formation of slags containing any considerable proportion of iron is prevented, and the yield of the furnace is increased; whilst also by the production of a more fusible slag the reduced metal better separates itself from the earthy constituents of the ore. In Staffordshire, where clay-ironstones with red and brown hæmatites are smelted together, the silurian and carboniferous limestone is employed as the flux; and in Cleveland the limestone from the Pennine Range* containing from 87 to 96 per cent. of calcic carbonate is employed.

212. In the *treatment of calcareous ores* it becomes necessary to add argillaceous materials as a flux, when the most convenient and generally adopted procedure is to add a certain proportion of clay-ironstone to the charge.

213. Highly *fossiliferous limestones*, owing to the

presence therein of notable proportions of earthy phosphates and of pyrites, are to be avoided as fluxes; and *dolomites* (magnesian limestone) are also less preferable than the more calcareous varieties of limestone, since magnesia decidedly diminishes the fusibility of blast furnace slags.

214. The *use of caustic lime* in lieu of raw limestone effects a saving of 30 per cent. in the amount of fluxes to be added to the charge; whereby there is an increased make of iron per furnace, together with a small economy in fuel, since the loss of heat in the furnace, due to the expulsion of carbonic anhydride (CO_2) from the limestone, is avoided by the use of caustic lime; but the additional cost of the caustic lime over raw limestone has prevented its general application. If the furnace top be smoking hot there may arise a further loss of fuel owing to the reduction of the carbonic anhydride to the state of carbonic oxide by the carbon of the fuel, which carbonic oxide then escapes without doing any useful work of reduction.

215. **Slags from the blast furnace** differ widely in physical characters, according to the nature of the ore and the fuel; to the quality or grade of the pig-iron being produced; according as hot or cold blast is employed, and also as the burden of the furnace varies from light to heavy. Hence deductions as to the working of a furnace cannot safely be made from an examination of the slag alone. The slags produced in two different localities, under normal and similar conditions, may be very similar, but it does not at all follow that the iron produced in the two furnaces will be the same. On the contrary the two are often widely different, yet with the same furnace and similar conditions of charging, blast, &c., valuable indications of the working of the furnace are afforded by an examination of the slag.

216. Blast furnace slags are essentially double silicates of lime and alumina, of the composition represented by one or other of the formulæ $3 (\text{CaO}, \text{SiO}_2) + \text{Al}_2\text{O}_3, 3 \text{SiO}_2$, or $3 (2 \text{CaO}, \text{SiO}_2) + 2 \text{Al}_2\text{O}_3, 3 \text{SiO}_2$, of which the latter

contains double the amount of silica contained in the former. The latter or more siliceous slag is more largely the product of charcoal furnaces; whilst where coal or coke is the fuel employed the slags are generally more basic in character, and accord more nearly with the first-mentioned formula. The lime, however, in both formulæ is always more or less replaced by magnesia (MgO), ferrous oxide (FeO), or manganous oxide (MnO), whilst the silica is also sometimes replaced to a small extent by alumina; and, as indicated by the accompanying analyses, the slags often contain about one pound of potash to the ton of slag, with probably also a small

ANALYSES OF BLAST FURNACE SLAGS.

	From Downlairs making grey iron (Riley).	From Downlairs making white iron (Riley).	Cold blast furnace working with coke (Percy).	Cleveland slag.	Producing grey Bessemer slag, disintegrates in air.	Swedish charcoal blast furnace (Ullgren).	From Cleveland pig-ores (Bell).	Scouring cylinder, South Wales pig (Nord).
Silica	38.48	43.07	39.52	36.50	31.46	46.37	27.68	42.96
Alumina	15.13	14.85	15.11	22.59	8.50	4.30	22.28	20.20
Lime	32.82	28.92	32.52	32.68	52.00	38.64	40.12	10.19
Ferrous oxide	0.76	2.53	2.02	0.06	0.79	0.95	0.80	19.80
Manganous oxide	1.62	1.37	2.89	0.32	2.38	1.86	0.20	1.53
Magnesia	7.44	5.87	3.49	5.83	1.38	7.40	7.27	2.90
Calcic sulphide	2.22	1.90	2.15	—	2.96	—	2.00	1.32
Sulphur	—	—	—	1.74	—	0.03	—	—
Alkalies	1.92	1.84	1.06	0.96	—	0.45	—	1.10
Phosphoric anhydride	0.15	—	—	—	—	trace	—	—
	100.54	100.35	98.76	100.68	99.47	100.00	100.35	100.00

proportion of soda, both alkalies existing as sulphides. It is further noticeable that the slags containing the larger proportion of manganous oxide, or of lime, most frequently also contain a larger proportion of sulphur than those in which these bodies are present in smaller proportions.

217. The colour of blast furnace slags varies from white or grey, through varying shades of brown, yellow,

green, and blue, to black. Generally a white or grey slag is indicative of a furnace working upon light burdens and producing grey iron; whilst dark-coloured or black slags result when the furnace is making white iron and working upon heavy burdens; but the colours of the slags are also influenced by their chemical composition, as affected by the nature, quality, or composition of the ores, and of the materials employed as fluxes in the furnace, as well as by the burden of the furnace. Traces of certain metallic oxides in the slag impart to it their distinctive tints; for instance, the presence of small proportions of *manganous oxide* (as occurs in the slag produced during the smelting of manganiferous hæmatites) suffices to impart an amethyst tint to the slag when seen in the massive form, although the colour is not apparent when the slag is vesicular or pumice-like in structure; and the presence of manganous oxide in the slag also tends, like lime, to separate a portion of the sulphur from the pig-iron being produced. If the burden of a furnace be increased so as to produce white iron, then the slag directly acquires a dark-green colour due to the presence of ferrous oxide, whilst the slag remains white or greyish so long as the furnace is working on the same ores, but with light burdens. *Manganous sulphide* also imparts a yellow or brownish-green colour to the slag, and the presence of excessive proportions of *alumina* manifests itself in the production of an opalescent slag, such as is frequently observed in Staffordshire from furnaces smelting clay ironstone. *Lime*, when in considerable proportions, is indicated by a dull stony fracture of the slag, and if it becomes excessive, the slag on exposure to a damp atmosphere disintegrates spontaneously and falls to powder; such slags, when ground to powder and mixed with about one-fourth of their weight of caustic lime, affording a good cement or mortar for building purposes. The presence of lime also decreases the fusibility of the slag, and generally a furnace producing such slags yields a grey and highly carburised pig-iron. Calcareous slags also take up a

proportion of the sulphur present in the fuel or in the ore, with the production of calcic sulphide, the presence of which is evidenced by the evolution when the slag is quenched with water of the characteristic odour of sulphuretted hydrogen (SH_2), or of sulphurous anhydride (SO_2) if the slag be not so far cooled as to prevent the escaping gases (SH_2) from taking fire on coming into contact with the atmosphere. A similar liberation of sulphuretted hydrogen or of sulphurous anhydride, according to the temperature, occurs also when baric or manganous sulphide is present in the slag which is treated with water. *Ferrous oxide*, as already stated, imparts to the slag a dark-greenish or greenish-black colour according as the proportion of ferrous compounds increases. The sky-blue colour of certain Swedish slags has been attributed to the presence of vanadium and titanium oxides, or of sodic sulphide, such slags constituting a kind of artificial ultramarine, but the evidence on this point is not conclusive. Zincic silicate is also said to give a green or blue tint to slags in which it occurs.

218. The several colours, as also the fracture of the slag, are often much disguised by the molecular condition induced by the varying rapidity or method of its cooling. Thus a slag which has been cooled quickly will present a vitreous conchoidal fracture, more or less translucent on the thinner sections, whilst if a similar slag be cooled more slowly it will show on fracture a dull, stony, opaque, and porphyritic appearance, and the same slag if allowed to flow over damp sand or through water, will become changed to a vesicular, brittle, friable, and pumice-like mass.

219. The *fusibility and fluidity of the slag* are also to a certain extent indicative of the working of a furnace, for, under the same general conditions, when the slag is refractory the furnace is usually producing grey iron, whilst a very fusible slag indicates that it is working on white iron. Slags which flow in continuous, steady, but more or less viscous streams, passing slowly from

the liquid to the solid state, are often produced when a furnace is working upon light burdens, and have generally a grey or whitish colour; whilst heavy burdens and a reduced temperature of the furnace are accompanied by a scouring slag or cinder, flowing as freely as water, and readily solidifying without passing through the viscous condition. These scouring slags are often also of a dark-green or greenish-black colour from the presence of ferrous oxide. *Scouring slags* may also attend the production of white iron, when the latter results from a partial reduction of the ferrous oxide in the molten ferrous silicate by a portion of the carbon of the pig-iron first produced and effected during the time that the molten metal and the slag are in contact on the hearth of the furnace. Forge- or mill-cinders when added to the furnace charge in appreciable proportion also result in the production of a dark-coloured, fusible, scouring slag, which, if much cinder has been added, sometimes yields as much as 20 per cent. of iron; yet since the original forge-cinder contained from 40 to 60 per cent. of iron its use is attended with an economy, although, as before stated, the pig produced is an inferior white, phosphoric, and sulphurous pig-iron, known as cinder-pig. In all cases the production of these scouring slags has a highly erosive action upon the hearth of the furnace. Slags which are the most fusible, perfectly fluid when melted, and vitreous after solidification, are generally the more siliceous in their composition, and often contain also considerable proportions of ferrous and manganous oxides, constituting the scouring slags above mentioned. The least fusible slags are those containing large proportions of basic or earthy substances, such as lime, magnesia, &c., and which present a dull, stony appearance.

CHAPTER VII.

THE BLAST FURNACE.

220. COMPARED with the huge, ponderous, conical masses of masonry, ranging from 30 to about 40 or 50 feet in height, as built previously to the last 20 years,—but of which few are now extant except in Sweden—the modern blast furnace is a much lighter structure, of a cylindrical casing of wrought-iron, lined with only a comparatively thin coating of radial brickwork, and is known, in contradistinction to the older form, as a *Cupola blast furnace*. The larger examples of the present date attain to over 100 feet in height and 25 feet in diameter at the boshes, against an average of 45 feet in height with 12 feet diameter of boshes in the year 1860. Further, instead of the well-defined divisions between the *stack*, *hearth*, and *boshes* of the furnace characteristic of the older types, the internal surface of the furnace is in recent practice marked by a more or less regular curve from the throat to the hearth, without any abrupt variation in the slope of the brickwork. Thus the Staffordshire and Scotch furnaces are usually built of such an internal curved form as will give a gradually increasing diameter from the throat to the boshes, from thence diminishing, either, according to the English practice, by a continuous curve to the hearth bottom, or, as in Scotland, to the top of a wide cylindrical hearth. In certain Welsh furnaces, however, the boshes are conical, and the stack, which is cylindrical, is terminated at the throat by a curved contraction or sort of dome, but in the Cleveland district curved stacks, conical boshes, and cylindrical hearths prevail. On the Continent the outlines of the internal form of the furnace are not so regular as in England, and generally the hearths are made smaller, (Fig. 9), whilst

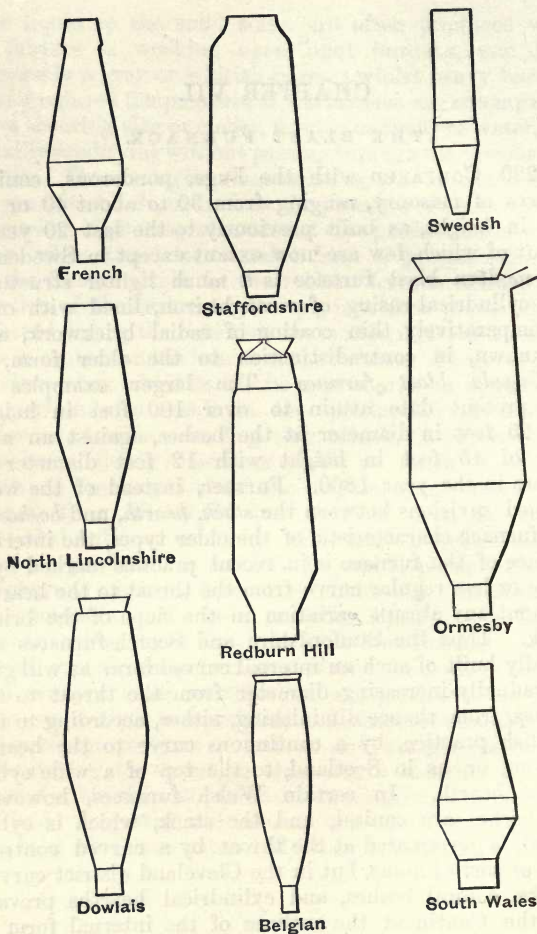

Fig. 9.—Diagram showing the Variations in the Internal Forms of Blast furnaces.

charcoal furnaces are usually of considerably greater height in proportion to the diameter than coke furnaces, and the angle or slope of the hearth and boshes is, as a consequence, very acute.

221. In the blast furnace for the production of pig-iron, the blast is supplied through nozzles or twyers laid approximately horizontal, and not at an angle downwards, as occurs when malleable iron is produced direct from the ore in the small Bloomery furnaces of the United States and Canada.

222. As indicating the *increase in height and capacity of the blast furnace* of recent practice over that of twenty years ago, it will suffice to note that whereas in 1861 the Cleveland furnaces averaged from 60 to 70 feet in height, from 16 to 20 feet in diameter at the boshes, and had a capacity of about 12,000 cubic feet, in the same district the prevailing height is now from 90 to 100 feet, with from 25 to 30 feet diameter at the boshes, and a capacity of from 30,000 to 40,000 cubic feet. A furnace at Ferry-hill has been erected of 105 feet in height with 50,000 cubic feet capacity. In Germany, however, the furnaces are still much smaller than in England, the largest only having a capacity of perhaps 15,000 cubic feet.

223. The *best internal shape, size, and proportions of the blast furnace* are not capable of absolute determination by theoretical considerations alone; the dimensions varying with the nature of the ore and fuel (charcoal or coke) worked in the furnace, the pressure and temperature of the blast, and the rate of driving (amount of air to be blown into the furnace in a given time). The best practical guide of the proper internal shape of a furnace for working any particular class of ore and fuel is afforded by an examination of the form which a furnace working upon like materials presents when blown out after a working campaign. For, any errors in the original design of shape are marked in such a furnace by the addition or accretion of materials upon such parts as were originally

too large in diameter, and a corresponding undue wearing away of such other parts as were too small, until the furnace ultimately assumes its best form. Much, however, may be determined as to the variations in size and shape necessitated by differences in the ores, fuels, fluxes, blast, &c., by careful consideration of the qualities of these latter. Thus, although an addition to the height of a furnace, with a proportionate increase in the temperature and pressure of the blast, is generally attended by an economy in fuel, yet the height of a blast furnace is practically limited by the power of the fuel to resist crushing by the superincumbent materials of the charge. Hence tall furnaces such as those of the Cleveland district can only be applied where strong, hard coke is employed; the use of tender coke, coal, or charcoal thus limits the height of the furnace, and where such fuels are in vogue only comparatively low furnaces are of service. Moreover, anthracite coal, although strong, decrepitates during combustion, falling to powder and so interfering with the free passage of the blast towards the throat, which obstruction is further increased by the production of an infusible mass resulting from the mixture of the siliceous slag with the finer particles of coal resulting from the decrepitation of the fuel, whereby the blast is prevented from penetrating through any considerable height of such materials. Furnaces consuming anthracite are for this reason much lower and wider in proportion to height than the Cleveland furnaces; whilst the pressure of blast and the number of tuyers in the anthracite furnace are also greater than are required for a coke furnace of the same height.

224. The *mouth or throat of the blast furnace* must necessarily be contracted to a smaller diameter than the boshes, in order to facilitate the charging of the ore, fuel, and fluxes, as also to ensure a better and more uniform distribution of these materials over the surface of the charge previously introduced into the furnace. And in passing it may be noted that the cup and cone arrange-

ment, to be subsequently described (p. 121), for closing the throat of the furnace, affords a most convenient means for charging and uniformly distributing the materials of the charge, since it delivers the charge upon the materials already in the furnace, in the form of an annular ridge with its sides sloping towards the centre and also towards the circumference—a condition very favourable to regular working, since there is then a tendency for the larger pieces of ore and fuel to settle towards the centre and circumference of the surface of the charge; whereby a more equable draught through the entire horizontal section of the furnace is maintained, and the bulk of the ore descends slowly through the centre of the furnace, which is the most highly heated by the ascending gases, and so favours an economical and regular or uniform working of the furnace. With throats that are *too wide*, the tendency is for the larger pieces of ore and fuel, when charged into the furnace, to collect wholly towards the centre, thus forming a mass readily permeable by the ascending gases, and producing thereby a central current which induces a too active combustion in this region, resulting in an undue consumption of fuel, with a more prolonged or constant contact of the ironstone with the brickwork lining of the furnace, which is thus the more rapidly destroyed. The opposite condition of a *too narrow* opening for charging results in the small ore falling into the centre of the furnace, and these form a dense column through which the ascending gases are unable to penetrate, and so the deoxidation or reduction of the ore is retarded, and the furnace yields black scouring slags and white iron; hence the necessity of properly proportioning the cup and cone charging apparatus so as to avoid either a too wide or a too narrow aperture.

225. The furnace should obviously contract in diameter from the boshes or widest part towards the hearth; since in this region the volume of materials in the furnace is constantly decreasing, owing to the reduction and fusion of the metal, together with the fusion of the slags.

226. The *older form of blast furnace* illustrated in Fig. 10 has an internal shape like that of two truncated cones, of which the bases are joined by a narrow cylindrical belt, *a*, known as the *belly* of the furnace. The upper part, *b*, of the above-mentioned cones forming the *stack* or *body* of the furnace is larger and deeper than the lower or *boshes*, *c*, and while the boshes are built either of fire-brick or slabs of a refractory sandstone, the stack consists of an internal lining, *d*, of from fifteen to eighteen inches in thickness, of fire-brick set in fire-clay, and outside of which is a casing of refractory sand or broken scoriæ, *e*, supported by a concentric wall of brickwork, *f*; while outside of all is the massive brick or masonry-casing, *g*, the whole being well and strongly tied together by stout bands or hoops of iron. The masonry is further prevented from splitting during drying or heating up by building throughout the outer casing of masonry numerous channels, by which the escape of water and drying of the furnace are much facilitated. The upper cylindrical part, *h*, of the furnace is known as the *throat*; and in open-topped furnaces—that is, such as allow the gases and flame to escape directly from the throat into the atmosphere—the throat of the furnace is surmounted by a *tunnel-head* of from eight to twelve feet in height,

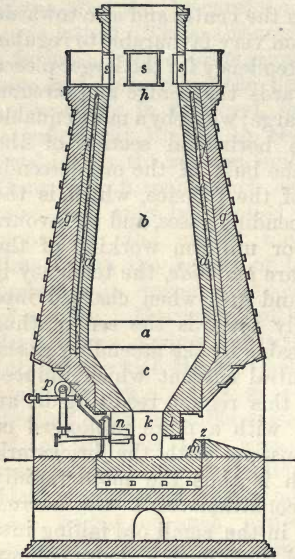

Fig. 10.—Sectional Elevation of a Staffordshire Open-topped Blast furnace.

throughout the outer casing of masonry numerous channels, by which the escape of water and drying of the furnace are much facilitated. The upper cylindrical part, *h*, of the furnace is known as the *throat*; and in open-topped furnaces—that is, such as allow the gases and flame to escape directly from the throat into the atmosphere—the throat of the furnace is surmounted by a *tunnel-head* of from eight to twelve feet in height,

and from eight to nine feet in diameter, which thus serves to carry the flame clear of the charging holes, *s*, which in such furnaces are built in the sides of the tunnel-head;³ but in closed-topped furnaces the tunnel-head is unnecessary.

227. Around the filling hole or throat of the furnace is carried a platform for providing a free passage to the barrows and waggons conveying the ore, fuel, and fluxes to the charging apparatus. This gallery is formed in the heavy furnaces just described upon the flat upper surface of the masonry of the stack, but in the cupola or more modern structure it forms an overhanging stage supported by brackets from the body of the furnace. The furnace slopes gradually from the boshes, *c*, to the *hearth*, *k*, and the whole erection rests upon a large heavy foundation of fire-stone or fire-brick, in which arched galleries are left for taking away moisture and keeping it perfectly dry; while the bottom of the hearth usually takes the form of a flat inverted arch, the concavity of which is upwards so as to prevent it from being raised by the accidental escape of metal beneath it. In front of the hearth, *k*, is an opening in the masonry, the crown of which, *l*, known as the *t ymp*, is made either of a block of refractory stone, or of a hollow cast-iron bearer or box built in the masonry, and through which a current of water circulates to keep it cool and to protect it from the heat and from the corrosive action of the slags. A little below and in front of the *t ymp* is a prismatic stone, *m*, called the *dam-stone*, supported on its outer side by a cast-iron plate known as the *dam-plate*, *z*. The portion of the hearth or space behind the *dam-plate*, which is arched over by the *t ymp*-arch, is known as the *fore-hearth*. A circular notch cut in the upper edge of the *dam-plate* constitutes the *cinder-notch*; whilst a vertical slot through the *dam* and *dam-plate*, extending to within about eighteen inches of the bottom of the hearth, forms the *tap-hole*, *t* (Fig. 11), which is stopped during the working of the furnace by sand or clay, introduced

on the end of a suitable bar and carefully tapped into the opening; and which plug or stopping is removed by a pointed bar, as required for tapping out the metal from the furnace. Frequently, on either side of the tump

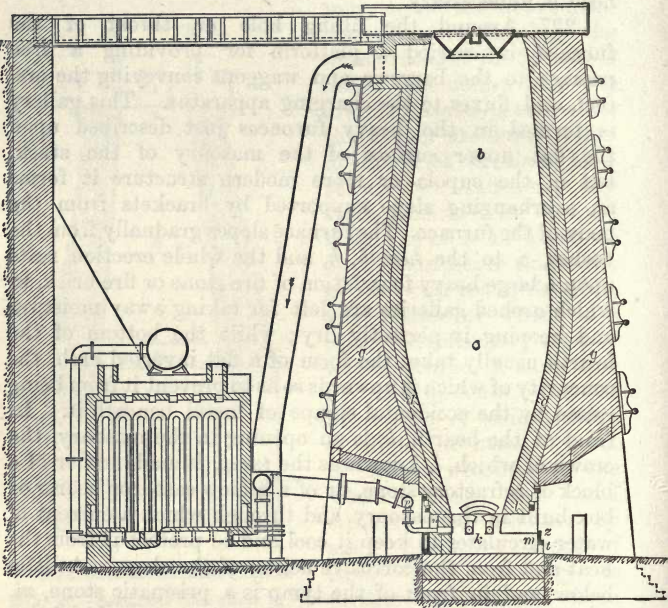

Fig. 11.—Vertical Section of the Older Type of Close-topped Blast furnace, with Rectangular Hot-blast Stoves.

are fixed cast-iron plates provided with notches, upon which the workmen rest their bars when cleaning out the hearth, &c. The twyer holes, *n*, varying from two to six or seven in number, are arranged around the circumference of the hearth and at some distance from the bottom of the same.

228. Fig. 12 is a vertical section, showing the general arrangement and construction of a cupola blast fur-

nace employed in the production of hæmatite pig-iron from English or Spanish ores, and differing only in size from many of the Cleveland furnaces. The same letters

of reference and names apply to the several parts of Figs. 11 and 12 as those already applied in the preceding sections to the older type of furnaces (Fig. 10); but there are also shown the *blast-main*, *p*, and the smaller pipes leading from it to each of the water-twyers, *q*, through which the blast is supplied to the furnace. The twyers vary in this class of furnace from three to six in number. In the cupola blastfurnace (Fig. 12) the body or stack is formed of a wrought-iron casing of $\frac{3}{8}$ -inch or $\frac{1}{2}$ -inch plates riveted together, and within which is built the outer casing, *f*, of ordinary brickwork, inside of which is the fire-brick lining, *d*, about 18 inches in thickness, built up of 5-inch fire-brick lumps all carefully dressed, faced, fitted and laid to the exact radius of the furnace in its several parts; while between this inner fire-brick lining and the outer casing of ordinary brickwork is a small space filled with sand or scorïæ. The stack

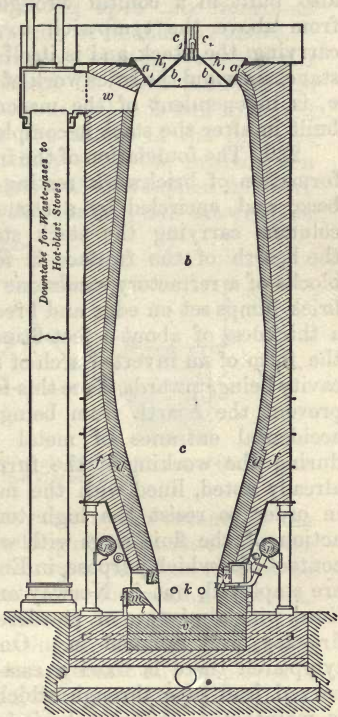

Fig. 12.—Vertical Section of the Cupola Blast furnace.

of such a furnace is carried upon a cast-iron ring, resting upon iron columns instead of upon the massive masonry pillars formerly employed ; and the lower conical part is also built in a conical wrought-iron casing, extending from above the tympan-arch to the top of the columns carrying the stack, and is itself supported upon cast-iron stanchions and the brickwork of the hearth. The hearth, *v*, is independent of the masonry of the stack, and is built in after the stack is completed.

229. The foundation of the furnace hearth is a massive formation of brickwork resting upon clay or other solid base, and encircled by a stone curb, upon which the columns carrying the stack stand. The bottom, *v*, of the hearth of the furnace is formed either from large blocks of a refractory sandstone or of two courses of fire-brick lumps set on edge and breaking joint, so as to make a thickness of about 4 feet 6 inches ; these are built in the form of an inverted arch of slight curvature, the concavity being upwards, since this form is the best adapted to prevent the hearth from being forced upwards by the accidental entrance of metal beneath the brickwork during the working of the furnace. The hearth is, as already noted, lined with the most refractory materials, in order to resist the high temperature and corrosive action of the fluid slags with which it is constantly in contact ; for which purpose, in England, the best fire-bricks are employed, but in Norway and Sweden the hearth is lined with a mixture of powdered quartz, fire-brick, and fire-clay, well rammed in. On the under side of the tympan-arch there is fixed a cast-iron box, in which is a curved iron pipe through which a circulation of water is maintained, and whereby it is better able to resist the corrosive action of the slags which are constantly flowing out from beneath it.

230. The cupola furnace, such as that just described, illustrated in Fig. 12, and employed in the smelting of hematite ores, will measure upon the average 65 feet in total height from the hearth to the platform, with a

diameter of 18 feet at the boshes and 7 feet at the hearth, while the bell-opening is 9 feet in diameter, and the furnace has a capacity of about 15,000 cubic feet. The Cleveland cupola furnaces generally working upon clay ironstones have, as already noted, a capacity of double the above.

231. The open-topped furnace with long tunnel-head is now generally discarded, except in South Staffordshire and Scotland, where coal is cheap, and it is still tolerated to burn the waste gases at the throat of the furnace; but in other districts, especially since the introduction of hot blast, some arrangement is always applied for more or less completely closing the throat; for drawing off

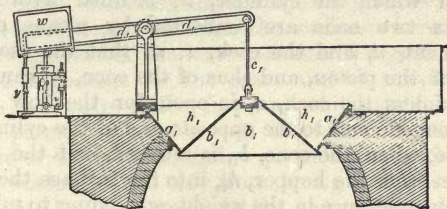

Fig. 13.—Cup and Cone Arrangement for closing the Throat of the Furnace and Collecting the Waste Gases.

the heated and combustible gases which ascend to the throat during the regular working of the furnace; and for conducting these gases into a suitable apparatus to be burnt, either under steam boilers for the raising of steam, in coke ovens for the production of coke, or more largely in the stoves employed for heating the blast blown into the furnace. The most general arrangement now employed is the *cup and cone* arrangement, shown in Figs. 12 and 13, whereby the throat is entirely closed and the gases wholly collected. The closure is effected by a cast-iron cup or funnel-shaped casting, a , of which the diameter at the lower end is about one-half of that of the throat of the furnace into which it is built; and beneath the lower extremity of this funnel-shaped casting a cast-iron cone, b , is suspended from its apex; this cone is connected by a chain,

links, or other means, c_1 , with a counterpoised lever, d_1 , the balance weight, w (Fig. 13), being adjusted so as to slightly preponderate over the weight of the cone, b_1 ; hence, immediately the charge has descended from the hopper, h_1 , into the furnace the balance-weight is sufficient to raise the cone, b_1 , back against its seating. Various mechanical devices are in use for controlling the movement of the cone, a frequent form being to attach a toothed arc to the opposite extremity of the lever to that at which the cone is suspended, into which arc is geared a toothed pinion worked by a hand-wheel. Another method illustrated in Fig. 13 consists of a cataract arrangement, in which the cylinder, x , is filled with water, whilst its two ends are connected by means of the arrangement, u , and the cock, v , so that the ascent or descent of the piston, and thus of the cone, b_1 , cannot be effected unless the cock, v , is open, for the flow of the water from one end to the opposite end of the cylinder, x . Therefore, when the cone, b_1 , is lowered, and the charge has fallen from the hopper, h_1 , into the furnace there is a small preponderance in the weight, w , tending to raise the cone and close the furnace mouth, but this movement cannot take place until the cock, v , is opened to allow of the passage of the water from the bottom to the top end of the cylinder, x ; hence all that is necessary is to open the cock, v , and the mouth of the furnace is immediately closed. Immediately this is effected the holding-down bolt, y , is attached, whereby the cone is held up, as also the charge in the hopper, h_1 , until it is required to lower the same into the furnace, when the rod, y , is thrown out of position and the cock, v , opened, upon which the cone immediately descends and the charge falls into the furnace as before. In this manner it is obvious that when the cone, b_1 , is raised, the furnace mouth or throat is quite closed, and the gases then pass out from the side of the throat through the pipe, w (Fig. 12), opening into the furnace above the level of the charge, and the gases are distributed by it for combustion at the boilers,

hot-blast stoves, &c., so utilising to a considerable extent the calorific power of these combustible gases. This method of closing the throat also affords a convenient mode of charging the furnace. For when the mouth is closed, the cup and cone arrangement forms a kind of hopper, h_1 , into which the supply of ore, fuel, and flux is placed as required, but as soon as the cone, b_1 , is lowered, the charge falls into the furnace. Owing to the form of the cone, the charge is distributed with tolerable uniformity over the surface of the materials already in the furnace; but the larger pieces of fuel and ore will tend to distribute themselves towards the centre and the circumference, while the smaller and heavier ore forms an elevated conical annulus upon the surface where it falls. This arrangement of the materials affords a good draught and a free passage for the gases around the sides and through the centre of the furnace, whilst the annulus of the less permeable ore descends through the hottest part or centre of the furnace, and so promotes economical and regular working. The only time during which the throat is open to the atmosphere is the short interval during which the cone is allowed to fall for the descent of the charge into the furnace; and a further advantage of this arrangement arises from the heating and drying which the ore undergoes while the materials are lying in the cup before their introduction into the furnace.

232. An alternative plan is in use in the Cleveland district for the construction of the throat of the furnace, which economises the space necessarily required by the last arrangement to permit of the descent of the cone into the furnace when the charge is introduced.* It consists in fixing the cone, b_1 , and then substituting for the funnel, a_1 , a movable cylinder of cast-iron, which is drawn upwards for the admission of charges falling into the furnace, and lowered immediately the charging is completed; but this class of arrangement does not distribute the materials as efficiently as the cup and cone arrangement.

233. In **Langen's apparatus**, as applied at Sieburg, &c., in Prussia, for collecting the waste gases, the furnace mouth is closed by a bell-shaped movable tube or lid, resting on an inverted conical ring; the whole being placed externally to the furnace. The bell is suspended from a lever above the throat of the furnace, and the charge is placed in the cup-shaped ring around the bell, so that when the bell-tube is raised the charge falls into the furnace. The lower end of the tube when lowered dips into a water-trough, whereby a gas-tight joint is obtained, whilst as a safeguard against explosion the arrangement is fitted with two safety-valves, one upon the conical ring, and the other upon the gas-tube. In Langen's arrangement the gases are withdrawn from the centre of the throat instead of from the sides, as in the previously-described plans.

234. A *modification of Langen's arrangement* is applied at Hörde, Prussia, in which the mouth of the furnace is closed by a flat plate or lid of cast-iron, in which are four holes for charging, each kept tight by valves fitted with water-joints. Above the lid is a gas-pipe 3 feet in diameter for drawing off the gases, and the pipe is connected with the lid by a water-joint to prevent the escape of gas. For the better distribution of the materials of the charge, the lid is provided with an arrangement of rollers, whereby it can be freely rotated but cannot be lifted or raised; and it is the practice, after each introduction of a charge by the four holes mentioned, to rotate the lid through one-eighth of a revolution before introducing another charge. The charging apertures are opened in quick succession, whereby the materials are rapidly introduced and distributed around the circumference of the materials already in the furnace.

235. In the charcoal furnaces of Sweden a partial collection of the waste gases without closing the throat in any degree is made by introducing a number of iron pipes through the brickwork of the furnace, at a depth of 10 or 12 feet below the top; but this method affords but a

limited and irregular supply of the escaping combustible gases.

236. Another form given to the top of some of the Ulverston furnaces working upon hæmatite is shown in Fig. 14, but it is not so general as the cup and cone arrangement shown in Fig. 13. The method illustrated in Fig. 14 consists of a wrought-iron tube, *a*, suspended in the throat of the furnace, and lined inside and outside with brickwork. It is supported on six arched ribs of brickwork, *b, b*, forming a kind of dome;

in this manner the throat is only partially closed, and but a partial collection of the gases is effected. There are six openings between the arched ribs for charging purposes; and the whole is fitted with a tunnel-head, in which are left six openings corresponding to the charging holes in the arched ribs, and

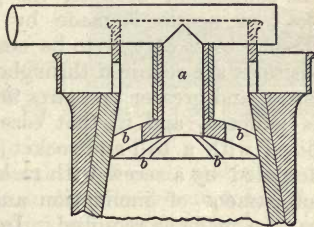

Fig. 14.—Sectional Elevation of Furnace Throat, showing arrangement for Drawing off Waste Gases by a central tube.

these openings can be closed by doors in the intervals between the introduction of the charges. The tube is about five feet in diameter, and extends for a distance of five feet down the throat of the furnace; it is connected at its upper extremity with a cross tube which conveys the collected gases to the hot-blast stoves, &c.

237. In such furnaces as are working with cold-blast the air passes direct from the blowing engines to the circular *blast-main* (*p*, Figs. 11, 12), and so to the twyers and the furnace; but if hot-blast be employed then the air passes in its course from the blowing cylinders to the furnace, through the hot-blast stoves or other apparatus employed for heating it. The *blast-main* (Figs. 11, 12), is a large circular pipe, placed at some distance above the level of the ground; it passes in the

older construction of furnace around the outside of the hearth and through arched openings in the heavy pillars of masonry upon which the stack is carried; but in the modern cupola type the blast-main is borne by the cast-iron columns which support the stack. Opposite to each twyer or metallic nozzle, through which the air is injected into the blast furnace, there is a branch pipe or "*goose-neck*" descending vertically from the blast-main to the level of the twyers. The *goose-neck* is joined to an elbow-piece connected with the horizontal blast-nozzles, and the connection between the *goose-neck* and the copper or iron nozzle is made by a stout leather coupling if cold blast only is to be employed. But metallic connections are required throughout for the higher temperatures, and greater pressures are employed when hot blast is adopted, and in that case the blast-nozzle is then fitted with a ball and socket-joint, with a telescopic-tube actuated by a screw with rack and pinion, whereby the adjustment of inclination and direction of the twyers can be made as required. In the angle of the bend or elbow between the *goose-neck* and the twyer, there is fitted a small slide containing a glass or mica plate, through which the state of the furnace may be observed; the bright spot thus seen is known as the "*eye of the furnace*." A throttle-valve is connected with each twyer for regulating the supply of blast, and a like valve is also placed between the hot-blast stoves and the blast-main.

238. The *water-twyers* always employed for hot-blast furnaces are fixed in the walls of the hearth, and their inner ends are thus subjected to an extremely high temperature and other destructive influences: for besides being exposed to a temperature of from 800° Fahr. to 1,400° Fahr., to which the blast is generally heated, their destruction is further hastened by the contact of molten metal and slag with their inner extremities. The twyers are of wrought- or cast-iron, or a combination of both, but they are also made of copper and of phosphor-bronze.

239. The *Staffordshire hot-blast twyer* is a hollow truncated cone (Fig. 15), through which a constant supply of water is maintained by the pipes shown in the figure for the introduction and withdrawal of the same, whilst the sheet-iron nozzle of the blast-pipe is inserted loosely into the axis of the conical twyer, the space around the nozzle and the twyer being plugged up with clay. The blast-nozzles point more or less directly towards the centre of the hearth, and are laid horizontally, except occasionally when it is desired to produce forge pig-iron, for which purpose the blast may be directed a little downwards towards the surface of the molten metal, whereby a partial decarburisation of the molten metal is effected, and white or forge-iron results. Such an inclination downward is also considered to promote the oxidation and partial elimination of sulphur, phosphorus, arsenic, &c., from the pig-iron; but on the other hand, if refractory ores are being smelted, or grey iron is desired, then a slight inclination of the twyer upwards is advantageous. New twyers are always made a little longer than necessary so as to allow

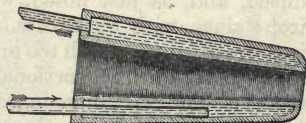

Fig. 15.—Section of the Staffordshire Hot-blast Twyer.

of the repair of their burnt inner ends without rendering the twyer unserviceable.

240. A modification of the hot-blast twyer just described is known

as the "*Scotch twyer*" (Fig. 16), and it is almost universally employed in the Cleveland district. This twyer, instead of being the truncated cone last described, consists of a spiral wrought-iron tube or pipe enclosed within a cast-iron casing, a current of water circulating through the coil to keep the twyer cool.

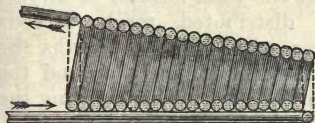



Fig. 16.—Scotch Hot-blast Twyer.

241. The *number, size, and arrangement of the twyers* in a furnace vary with the *size of the furnace, the nature of the fuel, and the amount of blast* required, as determined by the class of ore to be smelted and grade of pig-iron to be produced; since from the same ore white iron requires more blast for its production than grey iron. An excess, as also an insufficiency, of blast may thus be introduced into a furnace; the former condition resulting in an increased consumption of fuel per ton of pig-iron produced, and, as just noted, with the production of white iron: since with an excess of blast the reduction of the iron-ore progresses with too much rapidity, and the time for recarburisation is proportionately reduced; whilst, further, the excess of blast introduced into the furnace tends also to cool and solidify the slags, thus impeding the regular working of the furnace. The disadvantages arising from an insufficiency of blast are a reduced yield and the loss of heat in the furnace.

242. In small charcoal furnaces two twyers will often suffice, one being placed on each side of the furnace; but it is more usual to supply a third, which is placed in the back of the hearth opposite to the tump. In very large furnaces the twyers are often placed upon either side of the hearth in series of two each, while two more are placed at the back; or there may be three at each side, and one or two only at the back, but the total number of twyers to one furnace, however distributed, rarely exceeds seven. In cupola furnaces with circular hearths the twyers are usually placed at equal distances around the circumference of the hearth, thus better distributing the blast, and so also the heat and area of most active combustion within the furnace; but sometimes a special twyer is placed at the back for the purpose of clearing away any obstruction of imperfectly-fused matter that may collect on the hearth.

243. During the working of the blast furnace, the fused metal and slag as already mentioned gradually accumulate in the hearth in the intervals between tapping, and the

slag, owing to its lower specific gravity rises to the surface of the molten metal, thus protecting it during this period from the oxidising or decarburising influence of the blast. The space between the top of the dam and the tymp-arch is entirely closed during the working of the furnace except the small aperture or circular notch in the dam-plate already spoken of, through which the slag when it reaches to this level is allowed to run away, whilst the pig-iron continues to collect on the hearth. The furnaces are only tapped in the Staffordshire district at intervals of about twelve hours, but those making hæmatite require to tap out the metal after about every six hours. Before tapping the metal from the furnace, the *sand-bed* which gradually slopes from the front of the furnace is prepared for the reception of the metal; for which purpose a series of parallel grooves or furrows (*c, c*, Fig. 17) of a semi-cylindrical or  section are formed, usually with their long axes towards the tap-hole, while the top ends of the trenches or furrows in each row are connected with a common channel, *b, b*, running at right angles to them, and known as the *sow* or *feeder*. These feeders or sows are themselves put in connection with a common main channel, *d*, leading from the tap-hole to the lower end of the sand- or pig-bed. This sand-, or pig-bed, is of considerable size, and is usually exposed to the weather.

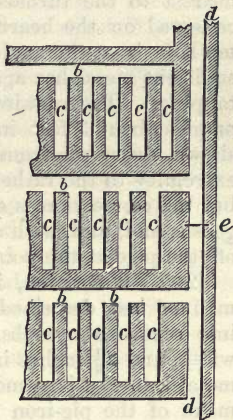

Fig. 17—Plan of Pig-bed.

244. In order to *tap the furnace*, the blast is turned off and the tap-hole is opened by an iron bar, when the metal flows from the tap-hole along the channel, *d*, to the lower row of moulds or furrows; and, when these

are sufficiently filled, communication between the transverse channel or sow, *b*, and the main channel, *d*, is cut off by driving down a spade at *e*, and placing a shovelful of sand against it; whereupon the metal takes the next channel nearer the furnace, and so on, each sow or transverse channel being put in succession into communication with the main feeding-channel *d*, so that the metal last flowing from the tap-hole is cast in the moulds nearest to the furnace. When the whole of the metal collected on the hearth has been thus tapped out, the tap-hole is again made up, and the blast turned on until sufficient metal has again accumulated to require another tapping. The cast-iron thus occurs in a series of bars or pigs about 3 feet in length and of the section above shown, every pig from the same row being united at one extremity to the rather larger transverse feeder or sow; but the connection is easily broken by the workman, who goes round, and, with a stroke of a large hammer, breaks off the pigs at the point of junction with the sow.

245. In Sweden, instead of casting in sand in the manner last described, the practice is to cast the metal into rectangular slabs, about 16 inches long, 9 inches in width, and $2\frac{1}{4}$ inches in thickness, by running the molten metal into cast-iron moulds in which the special brand or make of the pig-iron is marked on the bottom of each mould, and so occurs on each pig after casting. The practice of using iron moulds often partially chills the metal; and hence, as already mentioned, it is not unusual to find Swedish pigs whose fracture presents a skin of white, mottled, or chilled iron, enclosing a grey interior.

246. In Styria, the contents of the hearth are run through a channel partially closed by an iron shutter, when, owing to the specific gravity of the metal being superior to that of the slag, the former runs through the opening beneath the shutter into the sand-bed, where it forms a cake weighing from $2\frac{1}{2}$ to 3 tons, requiring about half an hour for its solidification; after which it is drawn from the sand-bed, allowed to cool down in the open air,

and then broken up into irregular fragments for use in the puddling or forge furnaces. The slag, which has been kept back, rises in front of the shutter and flows away into a separate channel, where it meets a jet of water, and is granulated or reduced to the state of a coarse sand, which is then available either for building purposes or is thrown away as waste.

247. The slag or cinder which is continually running from the cinder-notch during the working of the English blast furnace, and which amounts to about 30 cwts. for each ton of iron made, is often formed into large blocks by running it into a *cinder-tub*—that is, a shallow iron truck with movable sides—so that, when the tub is filled and the slag has sufficiently cooled down to become solid, the sides of the cinder-tub are moved away, by turning them upon the hinges by which they are attached to the end plate of the tub. The mass of slag is then either lifted from the bottom of the cinder-tub or bogie upon which it stands, and conveyed to the *cinder-heap*; or the bogie itself is drawn to the cinder-heap, and the block there thrown or tipped off on to the heap. As the cinder-tub is filled, it is either replaced by another empty one, or the channel through which the slag flows is diverted so as to run the slag into another tub standing alongside the one just filled.

248. In Staffordshire, instead of running the slags out into a cinder-tub, they are allowed to collect in a cavity or basin in the ground or floor of the casting-bed, and known as the *roughing-hole*, from whence, after solidification, the slag is lifted into waggons and taken to the cinder-tip.

249. In some small furnaces there is no cinder-notch, but, in front of the dam-plate, there is formed an inclined plane called the *cinder-fall*, over which the slags run, are allowed to solidify, and are then broken up by hand labour.

250. Instead of running out the slag, as above, into useless blocks, efforts have been made to utilise it economically for building and other purposes; and, in Staffordshire and the Cleveland district, a process has been

carried out for running the slag into cast-iron boxes or moulds, of shapes and sizes applicable to the pavement of footpaths and to building purposes. With this object the necessary moulds are arranged on the outer edge or circumference of a horizontal wheel of twenty or twenty-five feet in diameter, which is revolved by hand as the moulds are severally filled, the table remaining stationary during the filling of each mould. The slag is allowed to remain in the moulds until the blocks are sufficiently cold and solidified to bear removal without damage, and this condition is reached in the interval occupied in the filling of about one-fourth of the moulds, and the wheel has made one-fourth of a revolution. The slag-blocks are then allowed to fall from the moulds, and are at once removed while still hot to the annealing oven, where the bricks are maintained at a red-heat during twenty-four hours, and then allowed to cool down during a further period of twenty-four hours. The slag blocks or bricks so produced are said to be hard, compact, and to make a very durable material for pavements, since they have a high crushing strength but they are also liable to crack. Only certain qualities of slag are, however, available for the process; thus, a highly calcareous slag is inapplicable, since such would obviously absorb moisture, swell, and fall to pieces after any prolonged exposure to the weather.

251. In **Lurman's closed-hearth** system, adopted in some of the German furnaces, the hearth is circular in section, is closed and built without fore-hearth. The tapping and slagging holes are placed on opposite sides; the slag-hole being placed about 15 inches below the blast-twyer, and 3 feet 6 inches above the centre of the tap-hole; and the slag is often run into cast-iron moulds, so as to form slag-blocks for building and other purposes.

252. **Slag-wool**, or silicate cotton, sometimes employed as a coating for steam-boilers, steam-pipes, cisterns, &c., and of which much was expected, has not yet had any extensive practical application. It is prepared* by

* Proceedings of the Iron and Steel Institute, 1877.

directing a jet of steam upon the stream of molten slag as it runs from the furnace to the slag-waggon, whereby a portion of the slag is blown out into fine shots or pellets, which, in falling to the ground, draw a series of fine threads or filaments of slag between them and the molten stream of slag; and whilst the pellets, in virtue of their superior weight, fall down to the ground, the mass of woolly threads can be sucked into a large tube communicating with a large chamber covered with a fine wire-netting or sieve, into which the current of steam and air carries the slag-wool, which is deposited in suitable recesses, as also upon the sides of the chamber, while the heavier particles fall into the body of the chamber. After each blowing, the several portions of the slag-wool are separated, and selected for the various applications, or rejected, as may be.

253. The charcoal blast furnace used in Styria, and generally known as the *Blauofen* furnace, is distinguished by the smallness of the throat and the absence of any fore-hearth, the furnace breast being quite closed, so that both metal and slag are allowed to accumulate in the hearth until the time for tapping, when the slag and pig-iron are tapped out simultaneously at intervals of about three hours. The fluid siliceous slag, being lighter than the molten pig-metal, floats on the top of the fluid stream as it flows from the tap-hole; and by the introduction of a shutter into the stream the metal is allowed to pass into one cake, weighing some $2\frac{1}{2}$ or 3 tons, which is subsequently broken up into irregular pieces for introduction into the puddling furnace; whilst the slag which is diverted by the shutter into another channel is met by a jet of water, and is thus granulated or reduced to the condition of a coarse sand, in which form it is either used for building purposes in lieu of ordinary sand, or is simply carried away by the water into the river or other stream, and thence allowed to be washed away.

254. Some of these Blauofen furnaces in their latest modifications have yet but a capacity of 1,200 cubic feet,

and measure only about 30 feet in height, 4 feet 8 inches in diameter at the bottom of the hearth, 7 feet 2 inches in diameter at the boshes, with a diameter of 4 feet at the throat. The height from the hearth bottom to the top of the boshes is about 7 feet 2 inches, the height of the cylindrical stack above the boshes is 6 feet 3 inches, and the height of the upper conical stack to the throat 16 feet 6 inches; but others of these furnaces have reached to 40 feet in total height. The internal form of the furnace is thus that of two truncated cones, the bases of which are united by a short cylindrical stack. The hearth bottom of these Styrian furnaces is about 3 feet 3 inches in thickness, and is built of fire-brick free from quartz, while the inner lining is formed for fully two-thirds of its height from natural blocks of serpentine, above which, and including the throat, the furnace is lined with a talcose schist. Externally, it is built of rubble masonry, within which is a concentric wall of common brick, and between the two is a space loosely filled up with stones, &c.

255. The Blauofen furnaces employ a blast heated to from 500° Fahr. to 600° Fahr., which is introduced by three *inclined* water twyers, which thus, to a certain degree, convert the hearth into a refinery. The daily yield of about twenty tons of metal per furnace is of a white granular or laminated pig-iron, resembling refined iron, which contains about 3·25 per cent. of carbon, with 0·71 per cent. of manganese, 0·13 per cent. of silicon, 0·03 per cent. of sulphur, and 0·02 per cent. of phosphorus. The consumption of fuel in this furnace is about 16 $\frac{3}{4}$ cwts. of charcoal per ton of pig-iron produced, the furnaces being generally worked with heavy burdens; but if there is a tendency to scaffold or to become obstructed, a blank-charge—*i.e.*, a charge of fuel and fluxes without ore—is added, or simply two charges of fuel to one of ore are added to clear away any obstruction. The furnace charge works down from the throat to the hearth of these furnaces in from 4 $\frac{1}{2}$ to 5 hours.

256. The ores treated in the Blauofen furnaces are spathic carbonates more or less changed by oxidation into brown hæmatite, and they yield from 35 to 55 per cent. of metallic iron, with a little manganese. The ores are first roasted in kilns by the waste heat of the blast furnace, and are then exposed to the weather during several months for the solution of the sulphates formed by the oxidation of the sulphur during the roasting. The furnace charge of ore is made up of from 60 to 80 per cent. of roasted large ore, with 20 per cent. of unroasted small ore; besides which an addition of a siliceous clay is made, together with forge- or mill-cinder and lime as fluxes; while the fuel is the hard charcoal from the beech-tree, with a larger proportion of soft charcoal from the pine and the fir. The slags produced are therefore usually highly siliceous in composition, fluid when melted, and of a light green colour due to the presence of ferrous and manganous oxides.

257. The blast for the Styrian Blauofen furnaces is usually heated to from 480° Fahr. to 600° Fahr. (250° C. to 315° C.) in *pipe stoves of the Westphalian pattern*, each stove consisting of an arrangement of cast-iron pipes, generally twenty-four in number, arranged in six series or tiers placed horizontally one row above the other, all the joints and connections of the pipes being made outside the masonry of the stove. The air for the blast enters at one end of this series of pipes, and passes out after traversing the whole series from the outer end of the last pipe. The pipes or tubes are oblong in section, and measure about 12 inches in the major diameter by 3½ inches in the minor, and are heated either by a separate fire or by the combustion of the waste gases from the furnace.

258. The Swedish charcoal blast furnace is similar to the Styrian furnace last described, but differs from it in having a small and narrow fore-hearth. These furnaces have a capacity of between 600 and 2,500 cubic feet, the latter measuring 52 feet in height by 9½ feet in

diameter at the boshes, from which figures it is noticeable that the furnaces are much higher in proportion to their diameter than English coke-furnaces. The Swedish furnaces make upon the average from 30 to 60 tons of pig-iron per week, although in some of the larger furnaces, as those of Langbanshytta, with a cubic capacity of 2,300 feet, the yield has reached to 149 tons of white forge pig-iron per week. The temperature of blast employed in the furnace does not usually exceed 200° C. (392° Fahr.), and they chiefly smelt at Dannemora, Langbanshytta, and Langshytta the *self-fluxing ores* already described (p. 104), which contain from 50 to 60 per cent. of metallic iron. At Fahlun the charcoal furnace is of the cupola type, of which the stack walls are jacketed with $\frac{3}{8}$ -inch iron-plates, and is carried upon an iron ring supported by iron stanchions; whereby the circumference around the hearth is divided into eight similar segments, of which six are used as twyer arches, and one contains the slag outlet. This furnace has steep boshes, forming part of the same cone as the hearth, the angle of which is very acute; the cylindrical stack is 13 feet 6 inches long, and is surmounted by a funnel-shaped expansion to receive the wrought-iron cylinder which isolates the annular space for collecting the gases. The furnace has a total height of 55 feet, is 13 feet in diameter in the cylindrical part, and 5 feet in diameter at the hearth. It is usual in Sweden to form the hearth and lower part of the boshes to within about 10 inches from the furnace bottom of a mass of powdered quartz, rendered plastic by the addition of a little clay, this mixture being rammed around a cone of the form required, but the stack itself is lined with fire-brick. At Finspong, for the production of the cast-iron for guns, cold blast is still employed.

259. Rchette's blast furnace has been erected in the Oural mountains and other parts of Europe for smelting magnetic iron ores; and it claims to produce a more uniform and better distribution of heat in the furnace than is yielded by the usual circular-hearthed

furnaces, and also to effect an economy in fuel by retarding the escape of the waste gases; for, owing to the increase in the sectional area of the stack from the hearth to the mouth, the velocity of the ascending gases is diminished, and they thus remain longer in contact with the charge in the furnace, and so give up more completely their sensible heat before escaping into the atmosphere.

260. The Rchette furnace is rectangular in all horizontal sections, and the shaft gradually increases in width from the hearth to the mouth of the furnace (Fig. 18), the width at the top being from $2\frac{1}{2}$ to 3 times the width of the hearth at the tuyers. The length of the rectangular hearth is about five times its width, and the furnace is blown by 12 or 16 tuyers, placed 6 or 8 along each of the long sides of the hearth, but

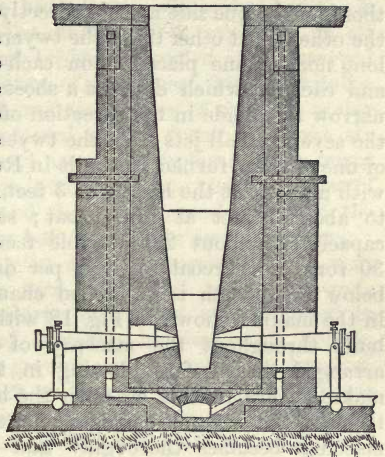

Fig. 18.—Sectional Elevation of the Rchette Furnace.

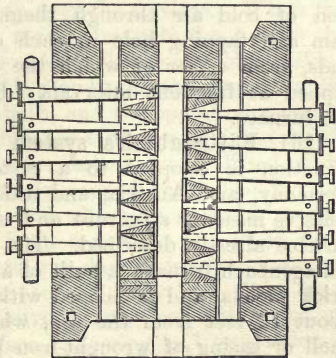

Fig. 19.—Plan of the Rchette Furnace.

placed 6 or 8 along each of the long sides of the hearth, but

those on the one side are not directly opposite to those on the other. At other times the twyers are replaced by two long nozzles, one placed upon each side of the furnace, and each of which delivers a sheet of blast from a long narrow slot made in the direction of its length in lieu of the several small jets from the twyers. The total height of one of these furnaces as built in Russia is about 30 feet, with a width at the hearth of 3 feet, increasing gradually to about 7 feet at the throat; such a furnace has a capacity of about 2,000 cubic feet, and makes about 30 tons of charcoal pig-iron per day. In the masonry below the hearth is an arched chamber, communicating in the manner shown in Fig. 18 with numerous channels built throughout the masonry of the stack, and so arranged that, before blowing in the furnace, by first making a fire in this chamber the heated gases circulate through the several passages mentioned, and thus the masonry becomes thoroughly and rapidly dried and heated; whilst during the smelting campaign these passages perform the opposite function of cooling down the hearth and masonry of the furnace by the circulation of cold air through them. The furnace has a dam and tapping hole in each of the shorter sides or ends, from either of which the metal and slag can be tapped at frequent intervals. Fig. 19 shows a plan of the furnace.

261. **Büttgenbach's system** of blast furnace construction is adopted to a certain extent in France, Germany, and Austria, and differs both from the old massive masonry structure and the cupola type of blast furnace already described. The body or stack of the Büttgenbach furnace is built of a single thickness of fire-brick blocks, and is hooped with iron rings except for about 12 feet from the top, where it is enclosed in a shell or casing of wrought-iron plates, so as to give the additional support necessary for carrying the charging platform and apparatus. The stack is carried upon an iron ring, supported either upon iron columns or upon

arches with red-brick buttresses; while the hearth is quite independent of the stack, and is accessible on all sides. The hearth and boshes are cooled and preserved against the corrosive action of manganese, &c., by building into them six or seven courses or tiers of cast-iron water blocks, which are protected at the front by about six inches of brickwork, and are easily replaced when burnt through. The water is introduced into the top course of these water blocks, and flows downwards through the lower ones successively before it passes away to waste.

262. **Iron smelting in Japan** is carried on in a very primitive fashion, the ores being first roasted in rude kilns for twenty or thirty days, and then smelted in furnaces consisting of a nearly hemispherical hollow, which is made in the ground and covered with brasque, whilst the blast to each of them is supplied through one or two clay nozzles from the ordinary smith's bellows. Working is commenced by first filling the concavity with charcoal, upon which a fire is lighted before the twyers, and the bellows are set to work, by which means the fire gradually increases, and a mixture of ore and charcoal is then thrown in a heap over the furnace. When the molten masses of metal reach almost to the twyers the blast is stopped, and the red-hot charge is pushed aside; upon which the fire is slacked by water, the slags are withdrawn from the molten bath, and the operation repeated as above until the whole furnace is filled with liquid metal, when the contents are either ladled out or lifted off in discs, or, though more rarely, tapped out. The furnace then requires to be repaired with clay, and the process as above is repeated. Such a furnace will yield from 3,000 to 4,000 lbs. of metal per day, with a fuel consumption of from 30 to 70 per cent. of the weight of the ore.

263. **Blowing in, blowing out, scaffolding, &c., of the blast furnace.**—Before "blowing in," or putting a furnace into blast, it is necessary that the masonry of the structure be thoroughly and slowly dried, to prevent cracking or fissure of any portion of the masonry. Having

been thus perfectly dried, the usual practice is then to build up the twyer-holes, and introduce into the furnace a quantity of rough old timber, sufficient to fill the hearth to a depth of 5 or 6 feet, and upon this sufficient coke is placed to fill the boshes. The timber is then ignited, and the combustion rapidly extends to the coke above it, whereupon successive layers of coke and limestone are introduced, until the furnace is about one-third filled, the limestone serving as a flux for the ashes of the coke. This charge is followed by light burdens made up of about three parts of calcined ore, with one part of limestone and two parts of coke, so gradually filling the furnace up to the throat; upon which blast-twyers of about one-half the diameter of those to be eventually used are inserted into the twyer-holes, and the blast put on so as to deliver about one-fifth of the blast required in the normal working of the furnace. This condition is continued for from 36 to 48 hours, after which the blast nozzles are changed for others of $\frac{3}{4}$ inch or one inch greater diameter, so as to deliver a proportionately larger amount of blast during the next 24 hours; and again, after the lapse of about three days from the first admission of blast, the twyers are changed for others of $\frac{3}{4}$ inch greater diameter than those to be replaced; and a further increase of $\frac{1}{2}$ inch in diameter is made to the blast nozzles at the end of about the third week. But it is not until some four or five weeks after the first introduction of blast, that the full pressure and volume of blast as required for the regular working of the furnace are employed, and in the interval it is usual to charge the furnace with light burdens and gradually to increase them with each increase in the pressure and amount of the blast, as introduced in the manner just described, until the fourth or fifth week, when regular charging and driving will have been attained.

264. In 12 hours after the admission of blast to the furnace, the slags first appear and begin to collect in the hearth, but about 24 hours elapse before any metal

appears ; after which it collects slowly and is tapped out as is necessary, but it is only after three or four days that the metal may be tapped from the furnace at regular intervals. When the furnaces are in regular blast about seventy-two hours are allowed in the Cleveland furnaces as the time required for the charge to pass from the top or charging plates of the furnace to the hearth, although in some of the smaller Continental furnaces the time is much less than this.

265. The furnace having thus been put into blast, or commenced its campaign, it is continued in uninterrupted work until it is necessary to stop either for repairs or from other cause. It occasionally happens that there is a temporary scarcity of ore, fuel, or the like, when it becomes necessary to stop the working for a short time ; and this can be effected by closing the throat and twyer-holes with sand or clay, under which conditions the furnace may stand for three or four days without much danger ; but if such delays are prolonged for one week or upwards then troublesome obstructions are likely to form within the furnace, perhaps necessitating the entire stoppage or blowing out of the same. A well-built blast furnace will run, under ordinary working and driving, for five or six years without requiring to be blown out for repairs, although the Cleveland furnaces sometimes last for ten or twelve years ; but very much depends upon the driving of the furnace, since excessively hard driving entails rapid waste and destruction.

266. When a blast furnace is to be stopped, or, as it is technically called, "blown out," the burden is gradually reduced so as to increase the working temperature of the furnace, and thereby facilitate the removal by fusion of any fusible obstructions hanging within the furnace. The tubes and fittings from the throat are then removed, charging is discontinued, and the furnace allowed to burn itself down, care being exercised to take the last tapping of metal from the lowest possible point in the hearth. After blowing out a furnace which has

been in blast during a lengthened campaign, there is often found in the bottom of the hearth an agglomerated mass of malleable steely-iron known as "bear" or "horse," and similar but smaller masses will be attached to various points around the sides of the hearth. These masses contain besides iron, also manganese, carbon, silicon, and copper, as also nickel, cobalt, and occasionally traces of the rarer metals, and sometimes copper-coloured crystals of a nitro-cyanide of titanium of the formula Ti_5, CN_4 .

267. *Obstructions technically known as "scaffolds"* occur not unfrequently in blast furnace working, and are often a source of considerable trouble. Scaffolds constitute impediments in the furnace arising from various causes, such as the faulty distribution of the charge, &c., whereby its proper and regular descent is prevented; so that, whilst the charge below the scaffold is working down, the mass above is left with a diminishing support from beneath, and the weight of superincumbent materials is at the same time constantly increasing by the addition of fresh materials at the furnace mouth. Under these circumstances the obstruction at a certain point frequently suddenly gives way, and descends with considerable force to the hearth, constituting what is known as a "slip." When a scaffold is discovered, the blast is eased so as to reduce the support from below due to the pressure of blast, and efforts are made to get down the scaffold without any sudden rush. Scaffolds also sometimes lead to the formation of a slight skew-back in the lining of the furnace owing to the erosion of the lining for some distance up, the effect of which is that a part of the stock or charge is held up, while other parts slide over it, and the furnace is thus found to work slowly and affords a diminished yield of metal. But scaffolds of the last class usually fill up with finely-divided fuel and ore in good condition for rapidly melting, so that, after working for some time in this condition, the heat and attrition of the descending charge will work off the irregularity in the lining, and

the materials of the scaffold will then work down quickly into the hearth, giving a much larger temporary yield to the furnace.

268. Amongst the causes contributing to the formation of scaffolds are: 1°, faulty shape of the furnace; 2°, the production of an imperfectly fusible slag; 3°, introduction into the furnace of too large a proportion of refractory ore in the charge; 4°, bad fuel, such as a weak friable coke which crumbles away under the weight of the superincumbent materials; and 5°, faulty charging, whereby the regular distribution of heat over the entire horizontal section is not maintained, owing to the larger pieces of coke collecting around the walls of the furnace, whilst the small and impermeable ore is concentrated in the centre.

269. *The effect of a scaffold* or obstruction in the furnace, is, besides preventing the regular descent of the charge, to obstruct the free passage of the blast and the escape of the furnace gases, as also to cool down the furnace and so thicken the slags.

270. **Hot-blast stoves, blowing engines, hoists, lifts, and other blast furnace appliances.**—The introduction of hot- instead of cold-blast has been attended with an economy in fuel and an increased make of iron by the furnaces, in the manner and for the reasons already stated. A temperature of 700° C. (1,292° Fahr.), or a visible red heat, is now commonly employed, whilst 800° C. (1,477° Fahr.) and upwards is not an unusual temperature of blast employed in the larger Cleveland and American furnaces. But in the production of these higher temperatures the *stoves* or *ovens* (as the apparatus for heating the blast is usually designated) of the older type, with cast-iron pipes or tubes, are rapidly destroyed; and other stoves, constructed upon the regenerative principle of Sir W. Siemens, have and are being rapidly introduced to the exclusion of the pipe stoves.

271. Of the methods for heating the blast by the waste gases of the blast furnace *without the closure of*

the throat, the earlier attempts were made by arranging within the tunnel-head a series of cast-iron pipes, through which the blast was forced; or the pipes were formed into a coil in the upper part of the stack; but in either arrangement the pipes were directly exposed to the heat and flame of the furnace top, or they were sometimes enclosed in brickwork; but the inefficiency, difficulty, and expense of repairs of such arrangements have led to their abandonment. In other methods of a like nature separate chambers were built outside the furnace, but a little below the level of the throat. Through these chambers the gases and flame from the furnace were drawn by a stack in connection with the same, and in that manner the blast passing through the pipes placed in these heating chambers or stoves was heated to the required degree. In the following examples of pipe-stoves or ovens, however, the stoves form separate structures independent of the furnaces, and in most instances the furnace-mouth is closed, and the waste gases are collected for combustion in the hot-blast stoves.

272. Of pipe-stoves or ovens, one of the earlier forms consists of a series of eight or twelve parallel or spiral arched pipes or tubes of cast-iron, of circular, oval, or elliptical section, arranged in an oblong chamber of fire-brick, along each of the long sides of which are two circular mains fitted with sockets, into which the legs of the vertical pipes are received, while between the mains, and running the full length of the stove, is a rectangular fireplace. The cast-iron pipes are Π -shaped, and stand vertically in the stove, with one foot in a socket upon the horizontal main running along one side of the furnace, and the other foot in a corresponding socket upon the main on the other side, and so the tubes span across the fireplace. There are stops or partitions in the horizontal main between each socket, so that the cold blast from the blowing engines, entering at one extremity of the one main, ascends from it through the first Π pipe

passing across the stove, and then back again by the next pipe, and so on to the other end of the stove, the cold air thus passing through the whole of the pipes before it leaves the stove by the hot-blast main to the furnace. The pipes are heated, either by fuel burnt upon the rectangular central fire-grate already mentioned, or by the waste gases from the blast furnace, which are collected for this purpose and burnt along the median line of the stove, by introducing the gases at one end and admitting air for their combustion through bars at the same end; hence in either case the flame and heated gases pass between and around the stove-pipes, thus heating the pipes on the exterior, and the products of combustion finally escape from a chimney in the dome or roof of the stove.

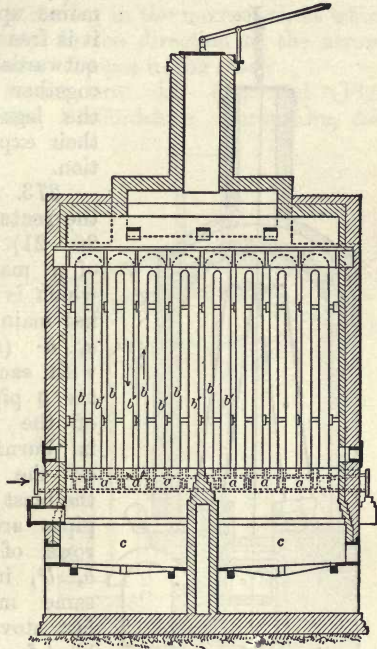

Fig. 20.—Longitudinal Vertical Section of Rectangular Hot-blast Pipe Stove, on line A B, Fig. 21.

To better absorb the heat, the stoves are usually divided into two chambers, by a partition wall reaching from the floor almost to the roof, so that the flame and gases first circulate through one half, and then pass over the division wall, and through the second half of

the stove, before escaping by the chimney. The stove-pipes frequently break by their own contraction and expansion as the temperature varies, and to mitigate this, it is usual to place one of the horizontal mains upon rollers, so that it is free to move inwards or outwards with the closing together or separation of the legs of the pipes by their expansion and contraction.

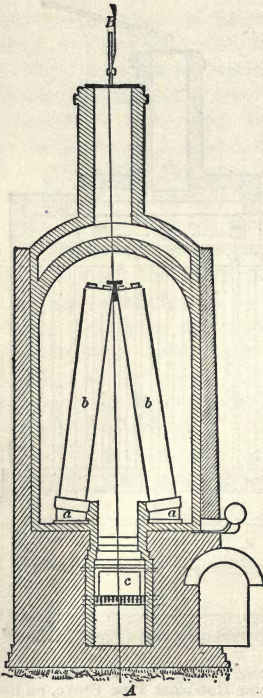



Fig. 21.—Transverse Vertical Section of Rectangular Hot-blast Pipe Stove.

273. Another form of the rectangular stove (Figs. 20, 21) consists, as before, of a masonry chamber, in which is placed a longitudinal main or series of stools, *a, a* (not communicating with each other except by the Π pipes), upon each side of the fireplace, *c*, where is burnt either solid fuel or the waste gases from the blast furnace. The stove-pipes are arranged in two rows, of six or more pipes, *b, b¹*, in each row, in the same manner as in the last stove, so that the cold-blast from the blowing-engine enters at one end and traverses the full length of each of the stove-pipes before it passes out from the stove to the blast-main, and from

thence to the twyers. The horizontal main of the stoves is formed by a series of stools, boxes, or hollow feet, *a, a*, each with two sockets cast upon it, so that the blast

ascends from the stool by one leg of the stove-pipe, *b*, and descends by the other leg, *b*¹, of the same pipe into the next stool, since the two legs of one pipe do not fit into the two sockets of the same stool, but stand one leg in one stool and the other leg in the next stool, in which manner the blast passes in the direction of the arrows through the whole series of pipes in the stove.

274. Circular stoves are also employed (Figs. 22, 23) in Lancashire, Staffordshire, Derbyshire, &c.,

instead of the rectangular forms just described, in which the two parallel mains at the base of the stove are replaced by a series of cast-iron boxes or stools, *a, a*, arranged so as to form an annulus or ring; while the horizontal section of the leg of each of the pipes, *b, b*, is either a circle or an oblong with semicircular ends thus . The pipes, *b*, are Π -shaped, with two parallel legs joined at their upper extremity either by a very short horizontal piece or by a curved piece as shown in

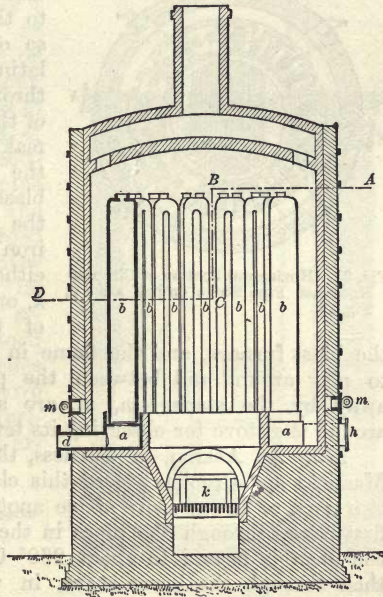

Fig. 22.—Sectional Elevation of Circular Hot-blast Pipe Stove.

Fig. 22; these pipes are placed almost close together all around the stove. Upon the circular main are sockets,

into which the legs of these pipes are received, the one open extremity of each of the stove-pipes fitting into the socket or seating on one of the stools, *a, a*, while the other extremity fits in like manner into a socket on the next stool or box, and so on around the stove. The cold air which is forced by the engines to the pipe, *d*, enters the stool, *a*, and ascends by the one leg of the stove-pipe standing therein, and descends by the other leg into the

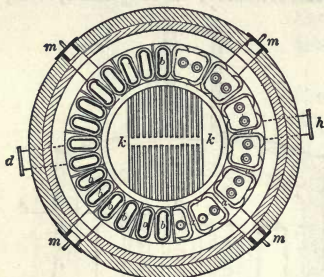

Fig. 23.—Horizontal Section of Circular Hot-blast Pipe Stove on line *A B C D*, Fig. 22.

next stool, and from thence by a second pipe to the second stool, and so on, the blast circulating in this manner through all the pipes of the stove, and finally making its exit by the pipe, *h*, to the hot-blast main, and so to the furnace. The cast-iron pipes are heated either by a central fire, *k*, or by the combustion of the waste gases of

the blast furnace, and the flame in either case is made to play around and between the pipes before passing away by the stack. *m, m*, are sight-holes, arranged around the stove for observing its temperature, &c.

275. At Askam, in Furness, the stoves of Messrs. Massicks and Crookes are of this class, but are built in two tiers, or as one stove above another. The cold blast first passes through the pipes in the upper stove, where the blast is heated to about 260° C. (500° Fahr.), and then through the lower stove, in which the temperature is raised to about 621° C. (1,150° Fahr.). It is claimed for this arrangement that the blast is maintained longer in contact with the heated pipes, and that it becomes accordingly more regular, while a higher temperature is also attained with less wear and tear upon

the stoves. These double stoves are about 47 feet in height.

276. The pistol-pipe stove is another form of the cast-iron pipe arrangement used for some of the furnaces in Cleveland, Scotland, France, and Germany. In this stove (Fig. 24) the two legs of the pipes in the previous arrangements are replaced by a single pipe, divided, as shown, by a septum or dividing rib, *b*, reaching from the mouth almost to the top or closed end of the pipe, and so practically dividing each pipe into two tubes. The closed end is enlarged slightly and bent over somewhat, so that its form bears some resemblance to the stock of a pistol, and hence the name. If the stove be heated by solid fuel, then these pipes are arranged on either side of a rectangular fireplace, *c*; and the pipes on each side of the stove lean over towards each other, so as almost to come into contact; thus the cold air enters at the bottom of the stove into one division of the stool or box, *a*, in which the pipes stand, and, since the stools are divided into compartments by divi-

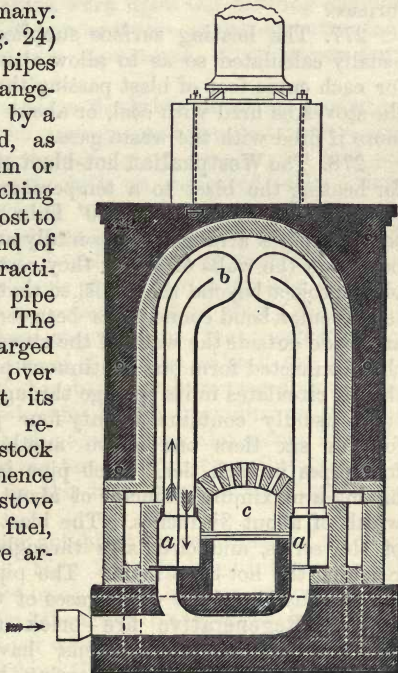

Fig. 24.—Vertical Section of Pistol-pipe Hot-blast Stove.

sions corresponding to those in the pipes, the air or blast ascends in succession through one side, as shown by the arrows, and descends along the other side of the division in each pipe, until it finally passes out from the end of the stove to the hot-blast main, and thence to the furnace.

277. The heating surface supplied by pipe-stoves is usually calculated so as to allow about one square foot for each cubic foot of blast passing through the pipes, if the stoves be fired with coal, or about 10 to 20 per cent. more if fired with the waste gases.

278. The Westphalian hot-blast stoves are employed for heating the blast to a temperature of from 249° C. (480° Fahr.) to 315° C. (600° Fahr.), and consist of a series of pipes arranged horizontally across a brick chamber, upon the walls of which they rest. The ends of the pipes project beyond the walls, so that the joints and the semicircular bend connections between the several pipes are made outside the walls of the stove, so that the pipes thus connected form one continuous pipe, through which the air circulates in its passage through the stove. Each stove usually contains twenty-four pipes, arranged in four or six tiers one above another, with three or four pipes in each tier. Each pipe is oblong in section, having a maximum diameter of about $13\frac{1}{2}$ inches, and a width of about $3\frac{3}{4}$ inches. The blast enters at one end of the series, and circulates through the whole before reaching the hot-blast main. The pipes are heated by the combustion of the waste gases of the blast furnace.

279. Regenerative fire-brick stoves, upon the principle of Sir W. Siemens, have met with considerable favour, and are coming into extensive use in lieu of the cast-iron pipe-stoves already described. The use of the latter is attended with serious loss and inconvenience, arising from the frequent fracture of the cast-iron pipes due to the repeated alternations of temperature to which they are subjected, and to the expansion and contraction of the pipes during the

working of the stoves. A further cause of fracture arises from the rapid oxidation and destruction of the pipes at the high temperatures now required in blast furnace practice; and these evils—viz., the burning and fracture of stove-pipes, leakage of blast, and a strong back pressure throwing extra work upon the blowing engines, coupled with a loss of temperature—are always attendant upon the use of cast-iron pipe-stoves, of whatever form they may be constructed.

280. The regenerative fire-brick stoves are heated by the combustion of the waste gases of the blast furnace, and their use has been attended by an economy in fuel per ton of metal produced; with an increased make of iron from the same furnace, and only a small amount of repairs; whilst the stoves require but a short stoppage for cleaning out, and give also a greater regularity in the temperature and pressure of blast, with greater economy in gas. These stoves are also capable of giving the highest temperature of blast required in the production of spiegeleisen. The size of the stoves of both the Cowper and Whitwell type has been much increased since their first introduction, whereby, besides providing an enlarged heating surface per stove, the gases also escape from the stoves at a much lower temperature than formerly, and greater regularity in the blast furnace working is the result.

281. The Cowper hot-blast stoves consist of an outer wrought-iron casing (Figs. 25, 26), lined internally with several rings of fire-brick work, built in courses of half a brick in thickness, the stove being closed by a dome-shaped roof, also lined with fire-brick as shown. Within this casing, and touching the fire-brick lining at one point of its circumference, is built up a circular fire-brick flame flue, *m*, at the base of which are the inlet valves, *g*, for the gases from the blast furnace throat and the valve, *A*, admitting the air necessary for the combustion of the gases; whilst *H* is the outlet valve for the hot blast. The body of the stove, as shown in the plan, is thus occupied by the regenerators

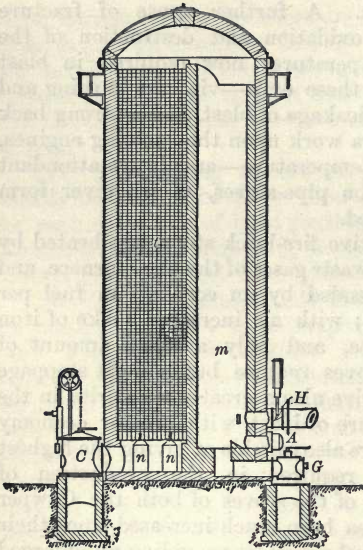

Fig. 25.—Sectional Elevation of the Cowper Hot-blast Stove.

vertical open passages of about 4 inches square through the entire height of the stove—that is, from the grids at the bottom to within a few feet of the domed top of the stove,—while opening below the grids already mentioned is the large chimney-valve, *c*. By this arrangement, when the chimney-valve is open, gas and air are also being admitted at the bottom of the flame flue by the valves, *G* and *A*, respectively; whereby the gas immediately

or fire-brick chequer work, *t*, at the base of which are the cold-blast valve, *B*, and the chimney-flue, *c*, while at *D, D* are the cleaning doors. Placed at intervals over the bottom of the stove are dwarf pillars, *n*, of brick or iron, which carry short girders upon which rests a series of strong grids, which support the regenerators or chequer work of fire-bricks. The bricks in the regenerators are now made smaller than formerly, measuring 2 inches thick, 5 inches in width, by 12 inches in length, and are arranged so as to leave

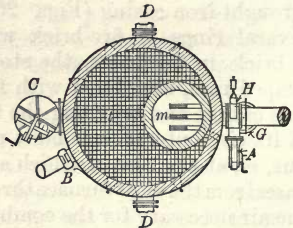

Fig. 26.—Plan of the Cowper Hot-blast Stove.

ignites and is split up into three currents by the divisions shown in the plan (Fig. 26); thus a more complete mixture of the air and gas is effected, and an immense flame ascends through the flame flue, spreading out beneath the dome over the top of the regenerators. The flame and heated products of combustion then pass slowly to the bottom of the stove, through the numerous square passages in the chequer work, before they escape by the chimney flue. In this manner the mass of brickwork within the stove, absorbing heat from the incandescent gases in contact with it, attains to a very high temperature, the upper layers of brickwork naturally becoming hotter than the brickwork near the bottom of the stove, while the products of combustion are reduced in temperature as they descend through the stove and finally pass out by the chimney flue, c, at a temperature of about 240° C. (400° Fahr.).

282. The stove having thus been heated by the combustion of the blast furnace gases within it, and by their passage through it in a state of incandescence, the *gas-valve*, g, the *air-valve*, A, and the *chimney-valve*, c, are then all closed, while the *cold-blast valve*, B, at the bottom of the stove is opened, as is also the hot-blast valve, H, near the bottom of the flame flue. In this manner it will be observed that the cold air then enters the stove at the lower or cool end of the regenerators, and slowly ascends through the height of the stove along the small but numerous passages of the regenerators, and from thence down again through the flame flue, and so out by the hot-blast valve, H, to the blast main and thence to the furnace twyers. The cold air thus traverses the stove in exactly the reverse direction to that followed by the gases in heating the stove, whereby the cold blast slowly takes up the heat given out by the brick surfaces of the stove, and the blast is quickly raised to a temperature of 815° C. (1,500° Fahr.) or redness. Since the blast first enters at the lower or cooler part of the stove, it is gradually heated to the above temperature without materially

cooling the upper layers of brickwork in the regenerators, before the lower parts have lost much of their heat, and in this manner the stove affords a very regular temperature, the upper part never falling below redness.

283. Two stoves are worked in conjunction, so that whilst one stove is being heated by the combustion of the blast furnace gases, the cold air is being driven through the other and heated to the temperature required for the blast furnace. Thus, two stoves are necessary for one furnace, or three stoves may be made to heat the blast for two furnaces. For conveying the blast at the temperatures attainable in these stoves, it has become necessary to increase the size of the main from the stoves to the furnace, so that it is now usually made about 3 feet in diameter, and is lined with a 9-inch course of fire-brick to prevent the cooling and corrosion of the mains.

284. For the cleaning out of the Cowper stoves, the spaces or passages between the bricks in one course of the chequer work or regenerators (whilst not coinciding exactly with those in the courses above and below, and yet overlapping partially the square openings in the several courses, but so as never to entirely cross them) form vertical channels, through each of which a brush or scraper can be introduced when necessary from the top to the bottom of the stove; but for the purposes of cleaning, it is generally found sufficient with these later arrangements of the chequer work, to discharge a small gun loaded with blasting powder three or four times at the top and bottom of the stove, when the concussion and vibration bring down to the bottom of the stove the dust, &c., lodging in the passages, &c., of the regenerators, which may then be removed from the bottom of the stove below the grates carrying the regenerators through the man-hole placed for this purpose. Occasionally a partial clearing out of the dust from the stove is effected by suddenly opening several times in succession a small door fixed on the gas-valve, or man-hole at the bottom of the stove, and the sudden expansion thereby of the large

bulk of compressed air contained in the stove blows out the dust through the man-hole; when this method of cleaning is pursued, it is effected as much as possible during the time of tapping, when the blast is shut off from the furnace, and all valves are closed except the one controlling the cold-blast from the engines.

285. Cowper stoves are usually built of from 50 to 55 feet in height, and from 20 to 25 feet in diameter, the larger dimensions giving about 75,000 square feet of heating surface. At the Ormesby works, two Cowper stoves are built 52 feet in height and 23 feet in diameter, affording a regenerator space of 14,500 cubic feet, with 71,000 square feet of heating surface, by which the 14,500 cubic feet of blast required per minute for the supply of a furnace making 500 tons of pig-iron per week, is raised to a temperature of 780° C. (1,436° Fahr.), and each stove works three hours without lowering the temperature of the blast more than 50° C. (90° Fahr.).

286. The Whitwell stoves differ from the Cowper stoves principally in the arrangement of the heating surfaces, which in this case consist of broad spaces and flat walls, instead of the chequer work employed in the Cowper-Siemens stoves; and they also differ in the method adopted for the combustion of the blast furnace gases for heating the stoves. Thus, while in the Cowper stoves the blast furnace gases and the air for their combustion are wholly introduced into one combustion chamber, in the Whitwell stoves the air is admitted at several points of the stove, so that the combustion commenced on the gases first entering the stove is only completed after the gases have traversed partly through the stoves.

287. The Whitwell stoves as built at the Consett iron-works are 22 feet in diameter and 28 feet 6 inches high, with a heating surface of 8,200 square feet; but they have more recently been built in England up to 68 feet in height, by 22 feet in diameter, and containing 26,000

square feet of heating surface ; while in America they are working as large as 70 feet in height and 21 feet in diameter, with a heating surface of 30,000 square feet. These stoves (Figs. 27, 28) are constructed of an outer shell or casing of wrought-iron plates, lined internally with fire-brick, while, to permit of the expansion and contraction of the lining, there is left a space of one inch between the iron casing and the lining, which space is usually filled in with granulated slag. Within this cylindrical chamber are built a series of long but narrow vertical chambers, *m, m*, communicating with each other at the top and bottom in the manner shown. The partition walls nearest to the point where the blast furnace waste gases first enter, become hotter than the rest of the stove, and are built thicker than those approaching to where the gases make their exit. In the construction of these stoves only the best quality of fire-bricks is used ; they are set in fire-clay, with the joints all carefully made.

288. The gases from the blast furnace enter the stove through the valve, *A*, fixed on the side of the stove casing, and, meeting immediately with the warm air passing from the air-valves (also fixed to the external casing) through the air-courses, *G, G*, combustion at once ensues, and the incandescent gases rise to the top of the chamber, distribute themselves over one or more walls, as indicated by the arrows, and descend through one or more smaller chambers towards the bottom of the stove, the gases imparting their heat to the fire-brick walls as they pass over their surface. A further supply of air is admitted, and mixes with the gases at the bottom of the stove ; here more complete combustion ensues, and the products re-ascend either by another wide combustion chamber, or, in the older designs, through two or three of the narrow chambers, and finally descend through the remaining chambers to the chimney-valve, *C*, from whence the gases pass away to the chimney at a temperature of from 149° C. (300° Fahr.) to 204° C. (400° Fahr.). The communications between the several

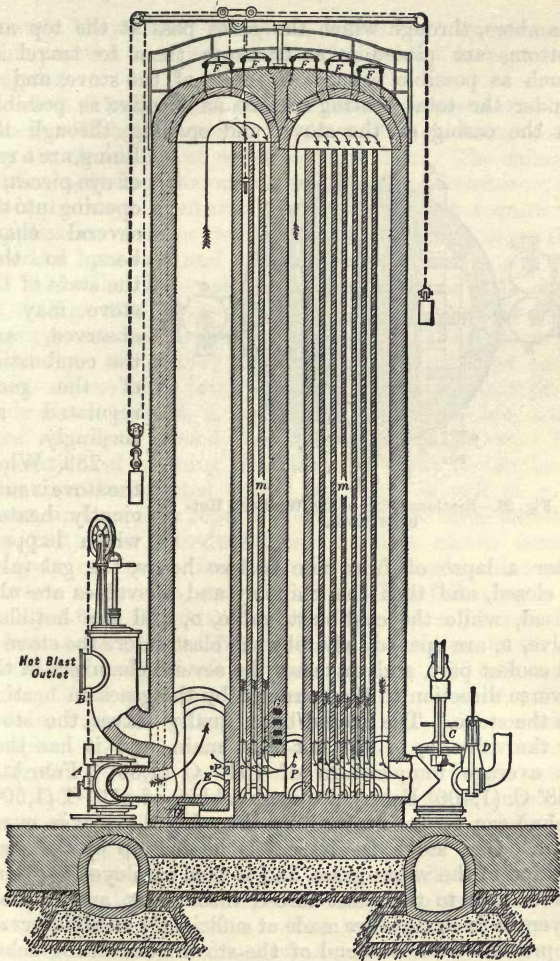

Fig. 27.—Sectional Elevation of the Whitwell Hot-blast Stove.

chambers, through which the gases pass at the top and bottom, are placed so as to cause them to travel as much as possible towards the sides of the stove, and so render the total heating surface as effective as possible. In the casing of the stove, and opening through the

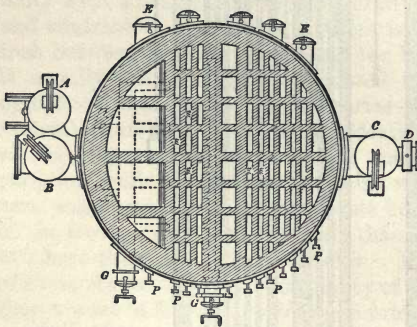

Fig. 28.—Sectional Plan of the Whitwell Hot-blast Stove.

lining, are a row of eye-pieces, P, opening into the several chambers, so that the state of the stove may be observed, and the combustion of the gases regulated accordingly.

289. When the stove is sufficiently heated, which happens

after a lapse of from one to two hours, the gas-valve is closed, and then the chimney and air-valves are also closed, while the cold-blast valve, D, and the hot-blast valve, B, are opened, whereby the blast enters the stove at its coolest part, and traverses the several chambers in the reverse direction to that pursued by the gases in heating up the stove. The heated blast finally leaves the stove by the valve, B, to the hot-blast main, and it has then an average temperature of 704° C. (1,300° Fahr.) to 738° C. (1,400° Fahr.), although a blast of 815° C. (1,500° Fahr.) can be maintained by changing the stoves every hour. One stove is alternately heated up by the combustion of the waste gases, and is then employed in giving up its heat to the blast forced through it, and if these reversals or changes are made at sufficiently small intervals to prevent the hotter end of the stove from falling below redness, it is assured that the gases always ignite imme-

diately they enter the stove, while also, by observing this practice the temperature of the blast is kept more regular.

290. The hot-blast and the gas-valves are of cast-iron, made with hollow casings to allow of their being cooled by the circulation of water through them. The chimney-valve, C, is a mushroom or dished valve of cast-iron, but being always comparatively cool does not require the application of water; while the cold-blast valve, D, is a slide worked by a rack and pinion.

291. The Whitwell stoves are provided with doors, F, F (Fig. 27), at the top of the stove, through which *scrapers* can be introduced for raking and cleaning out the dust from the walls; the dust, &c., so collected on the floor of the stove being afterwards removed through the side cleaning-doors, E, E (Fig. 28), six in number, which are arranged around the bottom of the stoves. This operation of cleaning occupies from eight to ten hours, but can be effected whilst the stove is still at a red heat, and requires repeating every two or three months.

292. The Flue-dust from hot-blast stoves consists largely of free silica, and silica in combination with potash, soda, lime, and alumina. The following is an analysis* of the dust from the flues of a German hot-blast stove of the Whitwell type:—Silica, 24·05 per cent.; potash, 17·05 per cent.; soda, 9·53 per cent.; lime, 25·95 per cent.; magnesia, 2·31 per cent.; ferric oxide, 1·30 per cent.; manganous oxide, 0·37 per cent.; sulphur, 1·71 per cent.; alumina, 10·09 per cent.; carbonic anhydride, water, cyanogen, and residue, 6·73 per cent.

293. Messrs. Massicks of Askam have patented and erected stoves similar to those of Whitwell, which claim to afford greater facilities for cleaning, and in which the most intense heat is obtained in the middle of the stove, whilst the brickwork is cooler from the centre towards the sides of the stove. This effect is produced by partially burning the blast furnace gases at the centre of a

* Dingler's "Polytechnische Journal," 1882.

combustion chamber in the bottom of the stove and completing the combustion in a second chamber at the top ; the necessary air for combustion in the latter being admitted by a separate valve. The products of combustion then circulate from the centre towards the circumference of the stove before escaping to the stack.

294. **Blowing engines**, and other mechanical appliances pertaining thereto, although of paramount importance for the successful and regular working of the blast furnace, are yet so varied in their mechanical details, that it is impossible to more than cursorily consider them in these pages, their complete description belonging more strictly to the province of the mechanical engineer than to that of the metallurgist. Here accordingly it will not be attempted to more than indicate the more general types of engines in use, and their mode of action.

295. The large blowing engines erected in the more recent works are either of the vertical direct-acting or of the beam-engine type ; but, generally, instead of the slow ponderous beam engines, more modern practice adopts the higher speed, short stroke, and direct action of the vertical engine, working with high-pressure steam, and either of the compound type or fitted with condensing arrangements. Some of the smaller engines, and many of the blowing-engines erected in the Rhenish Prussian provinces, and in France, are of the horizontal, direct-acting, condensing, or compound class. Engines of from 90 to 100 horse-power are required to force the blast necessary for an ordinary coke furnace, whilst from 30 to 40 horse-power will suffice for the blowing-engine of a charcoal furnace, where the pressure is lower and a smaller volume of blast is needed.

296. As already stated, the *amount of blast* required to be delivered by these engines is very considerable, amounting to about 14,500 cubic feet per minute for a furnace of 52 feet in height, making 500 tons of hæmatite pig-iron per week ; whilst from 50,000 to 60,000 cubic feet of air per minute, under a pressure of

from $3\frac{1}{2}$ to 7 pounds per square inch, are required to be delivered by the blowing engines for each of the large Cleveland furnaces; hence blowing cylinders of large diameter are necessary, and 80 to 100 or 110 inches in diameter are the usual dimensions.

297. The blowing cylinders are of cast-iron fitted with a piston receiving a reciprocating motion from the crank shaft of the engine. Suitable flap or disc valves of leather or of india-rubber are fitted in the cylinder covers, and arranged so that the piston in its movements alternately draws air into, and expels it from, either end of the cylinder at each stroke of the engine. Instead of the leather flap valves just mentioned, slide valves external to the cylinder have been fitted for opening the end of the blowing cylinders alternately to the air- and blast-main respectively, but these are not generally satisfactory, and the flap-valve is more usually adopted.

298. Fig. 29 is an elevation, partly in section, of one of a pair of direct-acting, high-pressure, condensing blowing engines, in which the steam cylinder, *s*, is forty-five inches in diameter, with a stroke of five feet, and is fitted with double-beat Cornish valves worked by cams; the air or blowing cylinder of the same engines is 100 inches in diameter. In the engines illustrated in Fig. 29, the air or blowing cylinder is placed vertically above the steam cylinder, but in some designs this arrangement is reversed, and the air-cylinder stands between the crank and the steam-cylinder. On the crank shaft between the two engines is fixed a heavy fly-wheel, *w*. As the piston, *p*, in the air-cylinder makes its forward or upward stroke, the eighteen leather disc valves, *f*, each about twelve inches in diameter, and fitted into the ends of the cylinder covers, open into the cylinder by the pressure of the atmosphere beneath them, and the air-cylinder is thus filled with atmospheric air; whilst during the same stroke of the piston the rectangular valves, *m*, opening from the cylinder to the blast-main, are closed against the face of the cylinder by the pressure of air within the main; and

then, as the piston commences its return stroke downwards, the admission valves, *f*, are closed by the pressure of the air thus compressed within the cylinder, and at

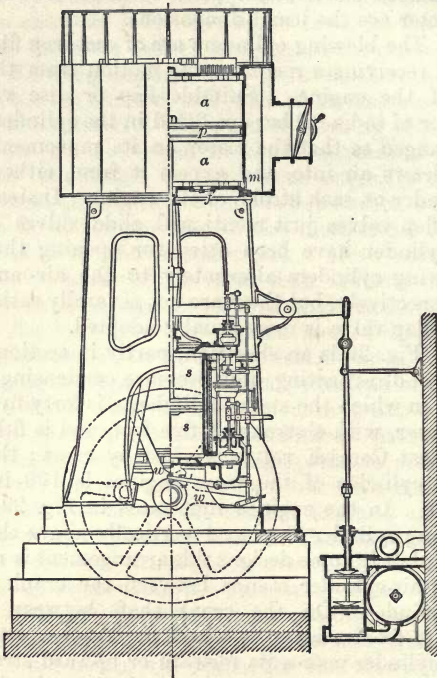

Fig. 29.—Elevation partly in Section of Blowing Engine.

the same time the pressure within the cylinder opens the exit valves, *m*, from the latter into the blast-main, whereby the air is driven by the engine into the blast-main, and so to the stoves and furnaces. Hence, as the piston makes its double stroke the air-cylinder is alternately filled with air at atmospheric pressure, and then emptied during

the return stroke by delivering its contents of air into the blast-main, at a pressure of from three and a-half pounds to seven pounds per square inch, as required for the working of the furnace. The action just described takes place both at the top and at the bottom of the cylinder; air being always admitted from the atmosphere into the cylinder on one side of the piston, while the contents of the cylinder on the other side are being driven out into the blast-main at the required pressure, and by this action an almost continuous stream of air passes from the engine to the blast-main, and so to the furnaces.

299. At the works of the North Lonsdale Iron Company three furnaces, each seventy-five feet in height, twenty-three feet in diameter at the boshes, and eight feet in diameter at the hearth, are supplied with blast by three pairs of vertical direct-acting blowing engines, having steam and blowing cylinders of thirty-two and sixty-six inches diameter respectively.

300. In the *beam engine* type of blowing apparatus the steam cylinders and fly-wheel shaft are on the same side of the centre-bearing or fulcrum of the beam, whilst the blowing cylinder is fixed at the opposite extremity. Compound beam engines at the Barrow Works have a high-pressure steam cylinder of 48 inches diameter with a stroke of 4 feet, 6 inches, and a low-pressure cylinder of 50 inches diameter, and stroke of 9 feet, and these are coupled to the beam on the same side of its centre, whilst on the other side of the centre is attached the blowing cylinder of 108 inches in diameter.

301. For the maintenance of an uniform pressure of blast, especially when the engines are placed close by the furnaces, it is often convenient to introduce between the engines and the furnace, an air-receiver or reservoir of considerable capacity, made of iron or masonry lined with cement; so that the elasticity of air within this receiver may serve to give a greater regularity to the stream of blast. In other cases a regulator, consisting of a

loaded piston working within a large receiver or cylinder, renders the supply of blast to the furnaces more continuous and regular. But these appliances become unnecessary where the blast-mains are of considerable diameter and length, since the elasticity of the large volume of air contained in the main between the engines and the furnace serves the same end; or also, where two or more engines discharge their blast into the same main, so that when one engine is delivering its maximum supply the piston of the other cylinder will be in the position corresponding to its least delivery of blast, between the two a continuous and regular supply is maintained.

302. **Hoists, Lifts, or Elevators** become necessary adjuncts of the blast furnace wherever the natural contour of the ground does not permit of an arrangement where-

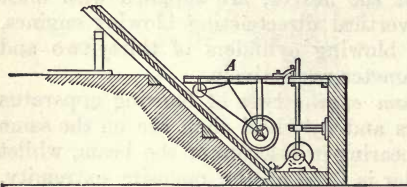

Fig. 30.—Inclined Plane for Elevating the Charge to Furnace Mouth.

by the loaded trucks can be run directly to the level of the charging - platform of the furnace; and in lieu of the long-inclined planes and winding machinery of

the older furnaces, the more modern plant is generally laid out for some form of the perpendicular lift, but still, as at Barrow-in-Furness and numerous other works, a modification of the *inclined plane* (Fig. 30) is in use for raising the ore, fuel, and flux from the ground level to the charging platform. At Barrow the inclined road is carried upon a pair of bowstring girders placed at an angle of from 25° to 30° with the horizontal, and the road is fitted more usually with two sets of rails, upon one of which the loaded truck ascends, while the empty one descends down the other. The carriage employed consists of a horizontal platform, A, supported upon a triangular frame

fitted with two pairs of wheels, of which the front ones are smaller than the back; and the lift is arranged so that when the carriage is at the bottom of the inclined plane it is received in a pit in the ground, and its platform is then on a level with the floor of the yard or shed, and the four or more iron wheel-barrows in which the charge is usually placed for elevation to the furnace top, can be wheeled directly on to the platform; and in like manner, when the lift has made its ascent up the incline, it stands so that the platform of the carriage is level with the charging platform, and the wheel-barrows can be wheeled directly on to the top. The motive power for this elevator consists usually of a pair of steam engines, working through friction gearing a winding drum of some twelve feet in diameter, around which passes a wire rope, the two ends of which are attached respectively to the ascending and descending platforms, while the action of the engine is controlled by steam brakes.

303. Of the *perpendicular lifts*, the *water-balance* is still in use at some of the older furnaces where a natural fall of water is obtainable, under which condition it is an economical and simple arrangement, although giving some trouble, owing to the difficulty of keeping the tanks water-tight; whilst if a pump has to be employed in lifting the water to the top for introduction into the tanks its advantages are seriously diminished. In the water-balance arrangement two cages or platforms are employed, beneath each of which is fixed a water-tight tank, capable of containing sufficient water to enable it when filled to draw up the other platform with its empty tank, and the load of ore or fuel. The two cages work between guides, and are respectively suspended from the extremities of a wire rope passing over guide pulleys. Thus, when one cage is at the furnace platform, and the other at the ground level, the tank of the latter is then emptied of its water through a valve fitted in the bottom of the tank, while the tank of the former is filled with water; in this

manner sufficient weight is added to the top cage to draw up the other cage with its load of charging materials from the bottom to the top of the lift, and so on, the tanks being alternately filled and emptied according as each one stands at the top or bottom of the lift, and in this way they ascend and descend in alternation.

304. In *hydraulic lifts*, or hoists, a ram, actuated by pressure from a hydraulic accumulator, is connected with a chain and system of pulleys whereby the move-

ment of the load to be lifted is some six or eight times greater than that of the ram by which it is actuated, according to the multiplying power of the chains and pulleys employed. In Fig. 31 is represented a simple form used in America, in which the ram of a hydraulic cylinder, *a*, terminates in two racks, *b, b*, which gear into two pinions on the same axle as the pulleys, *c, c*, around which the wire-rope, *f, f*, passes from the table, *e*, over the guide pulleys, *d, d*, so that, by properly proportioning the diameter of the pinion into which the rack gears, to that of the pulleys or drums, *c, c*, any desired velocity of ascent can be given to the cage.

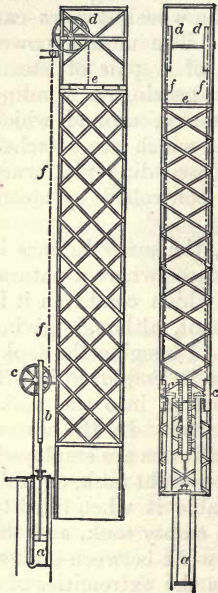

Fig. 31. — Side and End Elevation of Hydraulic Hoist.

305. Another *perpendicular lift* also in use, consists of two carriages, or platforms moving between vertical guides, and connected together by two steel ropes passing over a pair of deeply grooved pulleys, so that

as one platform ascends with a full waggon carrying about two tons of ore, the other one descends with

an empty truck. The grooved pulleys are some twelve feet in diameter, and the wire ropes by which the platforms are suspended are in contact with one-half of the circumference of each of the pulleys, so that as the pulleys revolve and the ropes are in tension under the load of the platform and truck, the friction between the ropes and the pulleys is sufficient to elevate the platforms; but immediately the descending truck strikes the ground the tension on the ropes is removed, and the pulleys will then revolve beneath the rope without further elevating the opposite truck, and so overwinding is prevented. Since one end of each rope is attached to the same carriage it becomes necessary to connect them to each carriage by double levers in such a manner that if one rope is slightly longer, or stretches under the load more than the other, then these levers adjust the lengths of the two ropes until each rope is put under a similar degree of tension. Upon the same shaft as the two pulleys is a large spur wheel gearing with a pinion upon an intermediate shaft, whilst upon the same intermediate shaft are two other wheels gearing with two other pinions on the crank shaft of a pair of small reversing engines fixed at the head of the hoist or lift.

306. *Pneumatic or compressed-air lifts* are frequently employed, in which the areas of the pneumatic cylinders are adjusted so that the pressure of from $3\frac{1}{2}$ to 6 or 7 lbs., as occurs in the blast-main supplying the blast furnaces, is sufficient to elevate the required load. In other arrangements, double-acting air-pumps by which air is forced into, or withdrawn from the cylinders as required, are employed. In the pneumatic lifts the cage or carriage moves between guides, and is supported upon a large air reservoir or cylinder, which works telescopically within another tube. The weight of the moving air-cylinder, with the cage, and other moving parts is nearly balanced by weights suspended from a chain passing over a pulley, so that the pressure of 3 or 4 pounds above the atmosphere as supplied from the blast-main to the

cylinders of 36 or 48 inches in diameter, suffices to lift the load of ore or fuel ; whilst the descent is made by opening a valve to the atmosphere, and allowing the compressed air to escape.

307. A modification of this arrangement is made by connecting the table or cage (carrying the truck with its load of ore) by chains, passing over a pulley, with one or more pistons working in as many cylinders, usually made open to the atmosphere above the piston, and then by connecting such an arrangement, in which the moving parts are balanced as before, with a set of double-acting air-pumps, so that a pressure of air of from 1 to 2 lbs. to the square inch above that of the atmosphere, forced in beneath the piston by these pumps, will cause the piston to ascend, and the cage with the empty truck to descend. On the contrary, if the pump valves be reversed, and air be pumped from the cylinder and discharged into the atmosphere, then a similar vacuum will be produced beneath the piston, which will descend and so elevate the carriage with its load of ore by the pressure of the atmosphere upon the upper side of the piston. When this method is adopted, the cylinders are often arranged so as to act as guides, between which the cage ascends and descends as described.

308. Direct-acting *steam-hoists* and *winches* of various types are also extensively employed in the elevation of materials to the furnace mouth from the ground level.

CHAPTER VIII.

FUEL, BLAST, CHARGES, YIELD AND WASTE GASES OF THE BLAST FURNACE.

309. UNDER special conditions, a considerable variety of fuels is available for use in the blast furnace, and it is found accordingly, under different local circumstances, and with special modifications of the furnaces

applicable to the conditions required by the several fuels, that *charcoal* and *coke*, *raw non-caking coal*, *anthracite coal*, *turf*, and even *wood* can be employed, although either charcoal or coke is the fuel more generally used.

310. **Charcoal**, owing to its usual freedom from sulphur, is conducive to the production of a pig-iron of superior quality; but, owing to its limited quantity and greater cost over other fuels, furnaces employing it are almost extinct in England and Belgium. Even in Sweden, charcoal is being superseded by coke; whilst in France and Germany, most of the iron is smelted with coke. From 16 to 17 cwts. of charcoal is the average consumption for the production of a ton of white or mottled iron, whilst from 21 to 22 cwts. of coke are required per ton of foundry or Bessemer pig produced.

311. **Coke** is the staple fuel employed in iron smelting, and in selecting the best coke, regard should be paid to its freedom from ash and to its power to resist a crushing pressure. Thus, a hard coke, yielding but a small proportion of ash or earthy matter, is in request; and the use of such coke, along with the introduction of hot-blast, has resulted in greater regularity of working, as regards both the quantity and quality of pig-iron produced. The hard, compact coke employed in the Cleveland district contains from 4 to 10 per cent. of ash, and from 0.25 to 1.0 per cent. of sulphur; and from 19 to 28 cwts., or on an average from 20 to 21 cwts., of such coke is consumed in the production of one ton of No. 3 grey foundry pig from Cleveland ironstone, yielding, after calcination about 46 per cent. of metallic iron; and about $\frac{1}{2}$ cwt. under or above these figures is required respectively for the production of a number under or above No. 3 pig in quality. Thus, if 20 cwts. of coke be required for the production of No. 4 pig-iron, then $20\frac{1}{2}$ cwts. will be necessary for the production of one ton of No. 3.

312. **Coal**, when used in the raw state in the blast furnace, should be of the non-caking varieties; and, like

coke, should be as free as possible from sulphur, and afford but a small per-centage of ash ; for all the ash or earthy matter introduced by the fuel requires to be fluxed by a corresponding addition in the amount of flux, thereby increasing the weight of unproductive materials introduced into the furnace. In Staffordshire, where open-topped furnaces are still to be found, some of them use a mixture of raw coal with coke, the coal employed being *non-caking*, and yielding from 4·2 to 4·6 per cent. of ash with from 0·3 to 0·5 per cent. of sulphur. Caking coal has a tendency to collect into lumps, and so to form obstructions within the furnace. For the consumption of raw coal, the diameter of the furnace-mouth should be increased, while a high pressure and hot-blast are also desirable. Raw coal is used in the State of Indiana, United States, in furnaces from fifty to sixty feet high, worked with hot-blast.

313. **Anthracite** is a dense pure coal ; hence its use is conducive to the production of a good quality of pig-iron ; but hot-blast at a high pressure is required for its working ; also the furnace should be low, and of a larger diameter in proportion to its height than is usual in coke-furnaces ; an increased number of twyers becomes therefore imperative, and in some furnaces as many as sixteen twyers are inserted. In large furnaces of the prevailing height and proportions, the use of anthracite fuel would be attended by a very slow combustion, and consequently by a sluggish descent of the charge, and a smaller make of pig-iron ; the smelting being also retarded by the decrepitation, or falling to powder, of such fuels, and the agglomeration of the slag with the decrepitated particles of fuel, producing thereby obstructions which materially interfere with the ready and free ascent of the gases towards the throat of the furnace. Accordingly, it becomes necessary to increase the pressure of the blast in anthracite furnaces, producing thereby a quicker combustion and more uniform ascent of the gases towards

the throat. South Wales, Scotland, and Pennsylvania are the chief centres for the use of anthracite coal in the blast furnace.

314. **Turf**, when employed in the blast furnace, is usually mixed with charcoal; but the results of its use are not satisfactory, since it is bulky, contains a notable quantity of sulphur, and yields a large per-centage of ash.

315. **Wood**, like turf, is generally employed along with charcoal and before use requires to be well air-dried and to be broken into pieces, not too large in size. But whenever wood is introduced into the blast furnace, the temperature of the upper zone is much increased, owing to the combustion of the gases evolved during the carbonisation of the wood, which takes place in the upper part of the furnace, and its use thereby induces irregularity in the working.

316. The amount of blast introduced into the blast furnace varies with the nature of the ore, fuel, and pig-iron to be produced, since grey iron requires nearly 50 per cent. less blast per ton of metal smelted than white iron. Thus, a small furnace of 7,500 cubic feet capacity, working on grey pig-iron requires 5,400 cubic feet of air per minute, or 1,700 tons weekly; while the same furnace, when making white iron, will require about 2,400 tons of blast per week. Hence, if the *pressure* of blast entering a furnace be kept constant, while the *volume* or weight of blast is increased, there will be a tendency in the furnace to make white iron; but, on the contrary, if the pressure and temperature of the blast be increased, without increasing the volume (and especially if the ores be also of a refractory nature), then the furnace will turn out mottled or grey iron. The injection of an insufficiency of blast results in a loss of heat in the furnace, with a reduced make of iron. On the other hand, an excess of blast is also productive of evil, for, with an excess of blast, there is an increased consumption of fuel per ton of pig-iron made, the reduction of the metal from the ore proceeds with too great rapidity, and hence the

time allowed for the carburisation of the reduced metal is decreased, and an inferior white iron results ; at the same time, the slags are cooled by the excess of blast introduced, and, becoming more or less solidified, interfere with the regular working of the furnace. The current of blast is maintained without intermission, except during the time of tapping or the introduction of the charge ; and the amount of air thus injected exceeds the aggregate weight of the ore, fuel, and flux charged into the furnace. Thus, in the Cleveland furnaces, for every ton of grey iron produced nearly $5\frac{1}{2}$ tons of air are forced into the furnace ; and the combustible gases collected at the throat during the same period require a further quantity of about $4\frac{3}{4}$ tons* of air to complete their perfect combustion. It has been stated† that in a Cleveland furnace of 35,000 cubic feet capacity, the amount of blast introduced was 91 cwts. per ton of pig-iron produced.

317. The necessary pressure of the blast likewise varies with the nature of the fuel and the burden of the furnace. Thus charcoal, being less dense and more readily combustible, requires a less pressure of blast than coke ; and accordingly, in some parts of Europe where charcoal is the fuel still employed, the pressure of blast does not exceed $\frac{3}{8}$ lb. per square inch, although the usual pressure for charcoal furnaces varies between $1\frac{1}{2}$ and 2 lbs. per square inch ; in England, with tender fuel, the practice is to employ a blast at a temperature of from $2\frac{1}{2}$ to 3 lbs. per square inch, and with hard coke, $3\frac{1}{2}$ to 5 or 6 lbs. is the pressure usually employed ; but in some of the American furnaces, during very hard driving, as much as 13 lbs. per square inch has been employed ; and, in the American anthracite furnaces, the blast has frequently a pressure of $7\frac{1}{2}$ lbs. to the square inch. The use of raw coal also makes a higher pressure and hot blast desirable. An

* Proceedings of Institute of Mechanical Engineers, 1883. Paper by Mr. Cochrane.

† Proceedings of the Cleveland Institute of Mining Engineers.

insufficient pressure of blast promotes scaffolding of the furnace; whilst a sufficient pressure of blast increases the make of the furnace, since with a low pressure the blast does not penetrate to the centre of the hearth, but ascends around the circumference of the furnace, and a column of imperfectly reduced ore and fuel consequently comes down the centre of the furnace, requiring to be reduced directly by solid carbon, whilst a large quantity of carbonic oxide must remain inactive and escape from the furnace throat.

318. The use of hot blast, patented by Neilson in 1828, and first used for the blast furnace at the Clyde Works, was attended at the Blyth Ironworks by the substitution of raw coal for coke in 1831. At the present time the use of hot blast is nearly universal, to the almost entire exclusion of cold blast, the exceptions being a few instances like Blaenavon, Pontypool, &c., in South Wales, which continue to make a limited quantity of cold-blast iron, which is sold at an enhanced price for special foundry applications. The temperature to which the blast is heated is regulated by the nature and quality of the fuel and ore, and the quality of the pig-iron to be produced; thus charcoal, from its inferior density and readier combustibility than coke, requires a less strongly heated blast, so that such furnaces only employ a blast heated to 100° C. or 200° C. (212° Fahr. to 572° Fahr.), while coal and coke furnaces ordinarily require a blast heated to between 600° C. and 700° C. ($1,100^{\circ}$ Fahr. to $1,300^{\circ}$ Fahr.), but in exceptional cases even higher temperatures are used. Likewise, in smelting refractory ores, a hotter blast is required than when easily reducible ores are being smelted. For the production of grey iron and of spiegeleisen, also, higher temperatures are employed than will suffice for white or forge iron, and for the production of ferromanganese the highest temperature practicable is required.

319. The degree to which the blast may be advantageously heated, appears to be limited only by the wear

and tear of the furnace and of the heating apparatus, and by the difficulty of keeping tight the several connections; and each of these difficulties is augmented with every increase in the temperature, but a proportionate increase in the make of pig and decrease in the consumption of fuel is at the same time effected. Thus, by raising the temperature of the blast from 400° C. (752° Fahr.) to 650° C. (1,202° Fahr.), proportionately increasing the height of furnace, &c., a reduction of 5 cwts. of coke per ton of metal produced has been effected, as is well illustrated in the following example, given by Phillips, of a blast furnace at Consett working upon Cleveland ore mixed with one-third of hæmatite: The smelting mixture yielded 48 per cent. of iron, and 17½ cwts. of coke per ton of metal were required when the blast was heated to a temperature of 720° C. (1,328° Fahr.), and the gases escaped from the furnace throat at a temperature of 250° C. (482° Fahr.); in a similar furnace working upon the same mixture of ores, but with a blast heated only to 450° C. (842° Fahr.), the consumption of coke was 22½ cwts. to the ton of pig-iron produced, and the gases from the furnace throat had at the same time a temperature of 470° C. (878° Fahr.).

320. The economy in fuel and increased make per furnace, effected by the introduction of the hot blast, are to be attributed to the larger hearth and increased height of furnace over what was practicable with the use of cold blast. Hot blast also affords a better distribution of heat throughout the furnace, whilst heavier burdens can also be worked for the production of the same quality of pig-iron. But for the production of any grade of pig-iron the use of the hot blast requires that the slags be more basic than where cold blast is employed; since with a higher temperature in the furnace, more silicon is reduced, unless such reduction is prevented by larger additions of limestone to the furnace charge, with the consequent production of a much more basic slag.

The use of hot air instead of cold, has the effect of producing an increased temperature in the vicinity of the twyers, owing to the combustion of the fuel being effected with more rapidity and lower down in the furnace; further, when cold air is first introduced into a furnace, a very considerable degree of expansion and consequent absorption of heat is experienced, and a further cooling down accordingly takes place in the neighbourhood of the twyers. By the use of the hot-blast the combustion of the carbon to carbonic anhydride is effected almost immediately the blast enters, and hence there is a considerable increase in the temperature, as above noted, in the zone of the twyers beyond what is produced when cold-blast is employed, and it is this increase in temperature in the zone of the twyers that necessitated the introduction of the water twyer. The higher temperatures that have been rendered possible by the use of the Siemens-Cowper, and the Whitwell hot-blast stoves (p. 155) have led to a great increase in the height of the Cleveland furnaces.

321. Materially affecting the yield and regular working of a furnace upon a given burden or mixture of ore, fuel, and fluxes, are the questions of the collection of the waste gases, and of the distribution of the charge over the surface of the materials already within the furnace. The *charging* and *gas-collecting* apparatus should be such as will most completely, and uniformly, expose the contents of the furnace to the heating and reducing action of the ascending gases, and for this purpose, besides a proper distribution of the charge, a free escape for the waste gases is desirable. The tendency of the heated ascending gases is to pass up the sides of the furnace, and hence it is desirable to avoid any method of charging which still further promotes this action. Thus, the worst kind of charging is where the charge falls in so as to form a conical elevation on the surface of the stock already within the furnace, for then, necessarily the

lighter and larger pieces of fuel will roll towards the sides, while the heavier and smaller ore will remain in the centre, and thus the free ascent of the gases around the sides will be facilitated, and there will collect a comparatively impermeable mass of ore in the middle. If the charge be introduced towards the circumference of the furnace, then the tendency is for the surface of the charge to assume a hollow or concave shape, in which the larger pieces of ore and fuel will gravitate towards the lowest or central part of the furnace, while the small ore collects towards the circumference. This arrangement gives a much better distribution of heat over the entire horizontal section than the previous method, unless, indeed, the diameter of the throat be wide, in which case the central draught becomes excessive and the consumption of fuel is increased, besides which the sides of the furnace get eroded by constant contact with the ore. As has already been seen, the most favourable condition for uniformly heating the charge and for the consequent economical and regular working of the furnace, is where the surface of the materials assumes the form of an annular ridge with its sides sloping towards the centre and circumference of the furnace respectively, when the ascending gases rise freely both towards the sides and the centre, and so the distribution of heat, descent of the charge, and working of the furnace are more regular.

322. In *charging a furnace* the ore, fuel, and flux are each weighed separately, and in coke furnaces the materials are introduced in successive layers; but in charcoal furnaces the materials of the charge are weighed out, and made up into a heap consisting of a series of layers of ore, fuel, and flux in the proportions determined by experience to be the most suitable for the burdening of the furnace. The furnace is then charged from this heap of materials by taking vertical sections through it, and introducing this mixture into the furnace.

323. The proportions of the several materials, ore, fuel, and flux, charged into the blast furnace for the production of a ton of pig-iron, obviously vary much with the nature of the ore (as to its richness and permeability by gases), with the density and quality of each of the separate items of the charge, and also with the temperature and volume of the blast, together with the quality of the pig-iron to be produced; hence the best and proper ratio of each material requires a separate determination for each furnace and locality. Generally, in the Cleveland district, from 19 to 28 cwts. of coke and from 10 to 14 cwts. of limestone flux are required for the production of a ton of grey foundry pig-iron from the Cleveland ironstone (argillaceous carbonates of iron), containing in the dry state 26 to 33 per cent., or after calcination from 35 to 40 per cent., of metallic iron, to the charge of which is sometimes added a little red hæmatite; or taking a particular furnace of 80 feet in height, 25 feet in diameter at the boshes, with a capacity of 30,000 cubic feet, the consumption averages 46·11 cwts. of calcined ironstone as above, 20·35 cwts. of hard Durham coke, and 10·71 cwts. of mountain limestone per ton of pig-iron produced,* the furnace working with blast at a pressure of $3\frac{3}{4}$ lbs. per square inch, and heated to a temperature of 593° C. ($1,100^{\circ}$ Fahr.). At the Ormesby† furnaces about 48 cwts. of calcined ironstone, yielding after calcination 41 per cent. of iron, with 12 cwts. of limestone, and 20 cwts. of coke containing 9·23 per cent. of moisture, sulphur, and ash, are required for the production of a ton of No. 3 pig-iron, in a furnace of 24,000 cubic feet capacity, and using blast at a temperature of $1,422^{\circ}$ Fahr. (750° C.).

324. In the Siegen district, for the production of spiegeleisen containing 8 per cent. of manganese, the charge is made up of roasted spathic ore 28·8 cwts., raw brown hæmatite 7·2 cwts., raw limestone 9 cwts., and

* Mr. Samuelson's Paper : Proceedings of Institute of Civil Engineers.

† Proceedings of Inst. of Mech. Eng., 1882.

coke 20 cwts.; the mixture of ores yielding 44 to 45 per cent. of iron, and the coke producing 8 per cent. of ash.

325. At the Edgar Thompson Works, U.S., working on ores yielding from 52 to 55 per cent. of iron, in furnaces 80 feet high, 20 feet in diameter at the boshes, and 11 feet 6 inches in diameter at the hearth, supplied through eight 6-inch twyers with blast at a pressure of 9 lbs. per square inch, and at a temperature of 649° C. (1,200° Fahr.), each furnace is reported to have yielded the extraordinary weekly output of 1,642 tons of No. 3 pig-iron for Bessemer use, upon a consumption of 20·83 cwts. of coke per ton, the coke containing more than the average per-centage of ash contained in English coke.

326. At the Consett Works, Durham, producing hæmatite pig-iron in furnaces 55 feet in height, 20 feet diameter of boshes, and 8 feet diameter of hearth, having a capacity of 10,300 cubic feet, and each driven by 7 twyers having 4-inch nozzles, with blast at a pressure of 4 $\frac{3}{4}$ lbs., and a temperature of 649° C. (1,200° Fahr.), there are required 41·5 cwts. of ore, 19 cwts. to 21 cwts. of coke, and about 8 cwts. of limestone per ton of pig-iron produced; and this furnace yielded during eight weeks an average weekly make of 806* tons 17 cwts. of Bessemer pig-iron, of which 53 per cent. was of No. 1 grade.

327. In the Barrow furnaces the charge consists of about 35 cwts. of ore used in its raw state, and containing on an average about 57 per cent. of iron, from 7 to 10 cwts. of limestone, and from 19 to 21 cwts. of coke to the ton of pig-iron produced.

328. At the Blaenavon Works, South Wales, the consumption of fuel (coke) during six months has been at the rate of † 11 cwts., 3 qrs., 26 lbs. per ton of iron, made in a furnace working with hot blast at a pressure of 3 $\frac{3}{4}$ lbs. to the square inch.

329. Belgian cupola blast-furnaces of 65 feet in

* Mr. Windsor Richards' address to the Cleveland Institute of Engineers, 1880.

† Proceedings of South Wales Institute of Engineers, 1882.

height, 23 feet 9 inches in diameter at the boshes, and 6 feet in diameter at the hearth, having a capacity of 15,536 cubic feet, make 113 tons of pig-iron per day, from Oolitic ores containing 38 per cent. of iron, with the consumption of 23·5 cwts. of coke per ton, the coke yielding 15 per cent. of ash.

330. In the American *anthracite furnaces*, the consumption of fuel amounts on an average to 25 cwts. of anthracite coal per ton of pig-iron produced, and in 1879 such furnaces 55 feet high and 16 feet in diameter at the boshes, blown with hot blast at a pressure of 7·8 lbs. per square inch, through six twyers, each made about 400 tons of pig-iron per week.

331. The Canadian *charcoal furnaces* making dark grey pig-iron require from 15½ to 23 cwts. of charcoal per ton of iron made. It is noticeable from these last figures that the consumption of charcoal in charcoal furnaces is much less per ton of metal produced than is the consumption of coke in coke furnaces, and that a greater amount of work is thus performed by the fuel in the latter than in the former, owing probably to the greater amount of flux and earthy matters that have to be converted into slag in the coke furnace than in the charcoal furnace using purer ores.

332. For the *production of the commoner classes of hot-blast pig-iron* of the Cleveland district, it is quite usual to add to the charge notable proportions of forge- and mill-cinder. These cinders contain from 40 to 60 per cent. of iron, with nearly the whole of the phosphorus, and much of the sulphur from the original pig; but owing to their ready fusibility and comparatively difficult reduction in the blast furnace, they melt and run rapidly down to the hotter parts above the hearth, where a portion only of the iron and sulphur are simultaneously reduced.

333. The *make or yield* of a furnace working upon an ore of a given richness is influenced very much by the condition of the ore, with respect to the facility with which it is acted upon by the reducing gases or

rapidity with which the furnace can be driven. The usual make of the modern Cleveland furnaces, smelting, as already mentioned, a mixture of Cleveland ironstone containing in the raw state from 26 to 33 per cent. of iron, with a little red or brown hæmatite, is about 30 tons of grey pig-iron per week for each 1,000 cubic feet capacity of the furnace, such furnaces using hard, compact coke as the fuel. The Luxembourg furnaces,* using an ore of the same geological position as the Cleveland stone, yield as much as 50 tons of white iron per week for each 1,000 cubic feet of capacity, while the American furnaces often yield as much as 100 tons of grey pig-iron per week for every 1,000 cubic feet capacity of furnace; but such driving probably renders the life of the furnace not more than a third of that of the Cleveland ones. The charcoal furnaces of Styria have made from 73 to 93½ tons of pig-iron per 1,000 cubic feet of capacity.

334. Since 1860, the average production of metal per blast furnace has just about doubled, for whilst, according to the mineral statistics of the United Kingdom, the annual production per furnace in 1860 was 6,574 tons, in 1870 it rose to 8,979 tons, and in 1878 it stood at 12,831 tons. In the large furnaces of the Cleveland district alone the output per furnace in 1876 was 330 tons, and it rose to 427 tons per week in 1880. This greatly increased output of the modern furnace over its predecessor is largely attributable to the *increased sizes of the furnaces*, the *better distribution of the blast*, to the *broader hearths*, the *steeper boshes*, the *better lines* for the internal form of the furnace, and the *greater volume, temperature, and pressure of blast* now prevailing, coupled with the necessary improvements in the blowing engines, by the substitution of direct-acting engines of higher speed and shorter stroke instead of the old slow beam-engines. The effect of raising a charcoal furnace 22 feet, or from 28 to 50 feet in height, and proportionately increasing the temperature of the blast from 200° C. (392° Fahr.) to 300° C.

* Professor von Tunner : Proceedings of Iron and Steel Institute, 1882.

(572° Fahr.) is stated by Professor von Tunner* to have reduced the consumption of fuel (charcoal) from 17 cwts. per ton in the smaller furnace to 13 cwts. per ton of metal produced in the larger; again, by increasing the height of a furnace from 60 to 75 feet there was effected a saving of $2\frac{1}{2}$ cwts. of coke per ton of iron made, the furnace working upon the same ironstone and coke as before.

335. The waste-gases passing from the throat of a Cleveland furnace 80 feet high, during the production of one ton of pig-iron, weigh nearly 7 tons, and from furnaces in Durham 55 feet high and smelting hæmatite, they amount to about 5 tons for each ton of pig-iron made. Another example may be quoted of a Cleveland furnace of 35,000 cubic feet capacity, in which the escaping gases amount to a little over 6 tons per ton of pig-iron made. Although these gases are generally spoken of as waste-gases, yet they are now largely collected and consumed in heating the blast, the raising of steam, &c.; since a large proportion, amounting to upwards of 25 per cent. by volume of these gases are combustible, and the calorific power of the escaping gases per ton of metal produced in the Cleveland furnace is equal to that furnished by the combustion of about $11\frac{1}{2}$ cwts. of coal.† Amongst the many eminent chemists who have from time to time examined the composition of the blast furnace gases passing at the throat and at different levels below, may be named Bunsen, Playfair, Ebelmen, Scheerer, Tunner, Schafhäütl, Rinman, and others, and their results agree upon the whole very closely, it being found that the gases escaping from the throat of the furnace contain in some form or other (chiefly as carbonic anhydride and as carbonic oxide) practically the whole of the carbon of the fuel introduced into the furnace, diminished only by the amount required for the recarburisation of the reduced

* Proceedings of Iron and Steel Institute, 1882.

† Mr. Stead's Paper before the Cleveland Institute of Engineers, 1882.

iron to the state of pig-iron, and the small amount escaping as cyanogen, in combination with potassium, as potassic cyanide.

ANALYSES OF THE WASTE GASES OF THE BLAST FURNACE
BY VOLUME.

	Alfreton furnace working upon calcined argillaceous ironstone and raw coal, blast heated to 626° F. (320° C.) (Bunsen and Playfair).	French furnace working upon brown hematite, lime and charcoal (Ebelmen).	Seraing upon brown hematite, mill, cinder, lime and coke, blast 212° F. (100° C.) (Ebelmen).	Charcoal furnace (Bunsen).	French furnace working upon hematite, lime flux, and charcoal (Ebelmen).
Nitrogen . . .	55.35	57.22	57.06	62.34	57.79
Carbonic oxide . .	25.97	24.65	28.61	24.20	23.51
Carbonic anhydride	7.77	12.01	11.39	8.77	12.88
Marsh gas (CH ₄) .	3.75	0.93	0.20	3.36	—
Olefiant gas (C ₂ H ₄) .	0.43	—	—	—	—
Hydrogen . . .	6.73	5.19	2.74	1.33	5.82
	100.00	100.00	100.00	100.00	100.00

336. An examination of the analyses of the gases shows that they do not essentially differ in composition whether hot or cold blast is employed in the furnace, unless when using the hot-blast raw coal be also used, when, besides the direct products of combustion, there are also recognisable traces of other volatile matters, condensable vapours, tarry matters, and ammonia derived from the distillation of the coal in the upper zones of the furnace; but practically the gases have the same composition whether charcoal, coke, or coal is the particular fuel employed. Nitrogen forms more than 50 per cent. and carbonic oxide (CO) about 25 per cent. of the total volume of the gases escaping from the furnace; but the higher the ratio of carbonic anhydride to carbonic oxide in the escaping gases, the greater is the economy in the con-

sumption of fuel; also the lower the temperature at which the gases escape from the furnace, the less is the waste of the fuel within the furnace. The ratio of oxygen to nitrogen in the gases is in excess of that in the atmosphere, so that a proportion of oxygen beyond that introduced in the form of blast escapes from the furnace-throat, and this excess is derived from the reduction of the oxides of iron in the iron ores, and from the carbonic anhydride expelled from the limestone added as a flux; while the free hydrogen, as also the hydrogen present in combination with carbon in the hydro-carbons mentioned, is derived from the decomposition of water vapour carried in by the blast.

ANALYSES OF THE WASTE-GASES FROM THE BLAST FURNACE (BY WEIGHT.)*

	Ormesby furnace of 35,013 cubic feet capacity.		Ormesby furnace of 20,454 cubic feet capacity.		Askam Furnace.	Cleveland Furnace.
	Blast 1357° F. (736° C.).	Blast 1507° F. (819° C.).	Blast 1630° F. (888° C.).	Blast 1569° F. (855° C.).		
Carbonic anhydride	18.70	18.36	14.45	13.42	13.47	14.37
Carbonic oxide . .	25.17	26.66	28.32	31.66	33.80	27.03
Hydrogen	0.01	0.07	0.20	0.12	0.14	0.06
Nitrogen	56.12	54.91	57.03	54.80	52.59	58.54
	100.00	100.00	100.00	100.00	100.00	100.00

337. Analyses of the gases present in the blast furnace at various depths below the throat show that the proportions of carbonic anhydride (CO₂) to carbonic oxide (CO) vary at the several depths. Thus, while in the upper part of the hearth the gases are chiefly nitrogen, carbonic oxide, and a little hydrogen, there is a

* Proceedings of the Institute of Mechanical Engineers, 1882 and 1883.

gradually diminishing amount of carbonic oxide as the distance above the twyers becomes greater; and this might be expected, for, as already explained, the oxygen of the blast is converted into carbonic anhydride almost

ANALYSES BY VOLUME OF THE GASES AT DIFFERENT DEPTHS OF THE ALFRETON FURNACE.

	Distance below the furnace mouth.				
	8 feet.	14 feet.	20 feet.	24 feet.	34 feet.
Nitrogen	54.77	50.95	60.46	56.75	58.05
Carbonic anhydride	9.42	9.10	10.83	10.08	—
Carbonic oxide	20.24	19.32	19.48	25.19	37.43
Marsh gas (CH ₄)	8.23	6.64	4.40	2.33	—
Hydrogen	6.49	12.42	4.83	5.65	3.18
Olefiant gas (C ₂ H ₄)	0.85	1.57	—	—	—
Cyanogen.	—	—	—	trace	1.34
	100.00	100.00	100.00	100.00	100.00

immediately it leaves the twyers, from which point a cycle of reactions is repeated, by which the *carbonic anhydride* is reduced by contact with incandescent charcoal to the state of *carbonic oxide*, and this latter, then reacting upon the oxides of iron in the ores, is oxidised back again to the form of carbonic anhydride, when the first reaction between carbonic anhydride and carbon is repeated, and carbonic oxide again results. These reactions repeat themselves as the gases ascend through the blast furnace, as long as the temperature remains sufficiently high; but since it requires a higher temperature for the reduction by carbon of carbonic anhydride to the state of carbonic oxide than is necessary for the reduction of ferric oxide by carbonic oxide, it follows that the oxidation of carbonic oxide to the state of carbonic anhydride will continue, although with a diminished energy, after the reaction between carbonic anhydride and carbon has

ceased; and accordingly it is found that the proportion of carbonic oxide in the gases gradually decreases with the distance above the tuyers. On the previous page will be seen analyses at different depths below the furnace mouth made at the Alfreton Furnace, Derbyshire, which was 40 feet in height, and was working upon calcined argillaceous ironstone, with a limestone flux and using raw coal, the blast being heated to a temperature of 330° C. (626° Fahr.), and worked at a pressure of about 3½lbs.

338. The current of waste-gases also carries over with it into the tubes and flues an amount of *dust*, containing silica, alumina, ferric oxide, lime, calcic sulphate and phosphate, with smaller proportions also of magnesia, manganic oxide, potash, soda; and if the ores contain zinc also, then this dust will contain in addition zincic oxide. This dust accumulates slowly in the flues, and requires to be cleared away from time to time; or it is separated by washing arrangements connected with the top of the furnace.

CHAPTER IX.

CASTINGS IN IRON, FOUNDRY APPLIANCES, &c.

339. ACCORDING to the nature and uses to which a casting is to be applied, the founder employs for its production special mixtures of pig-iron. Thus, in making light and ornamental castings, fluidity of the metal in its molten state, and adaptability to the taking of sharp impressions of the mould in which the metal is run, are of the first importance, whilst the strength of the casting is only a secondary consideration; but, on the other hand, in the castings for machinery, for girders, or for other structural ironwork, strength becomes of primary importance. It is thus evident that cast-iron which contains phosphorus and is a little cold-short, but is very fluid when melted,

will answer admirably for the light ornamental work first mentioned, although it could not safely be used for girders, railings and the like, which are subject to sudden strains or shocks, and require therefore a stronger and purer pig-iron.

340. It is always considered better to use a mixture of several brands of iron in a charge for any casting : thus, No. 1 of one brand is often mixed with Nos. 2, 3, and 4 of different other brands, since such mixtures are most frequently found to be stronger than the average of the several brands taken separately.

341. Scotch pig-iron, especially No. 1, is frequently employed in the foundry to give fluidity to inferior brands ; and cold-blast irons are added where considerable strength is required. Steam cylinders are thus invariably cast of a mixture of pig-irons containing one or more cold-blast brands, and generally a mixture which yields a close and compact grey iron is the best for general use. With a view to the production of tough close-grained castings, some founders add a proportion of wrought-iron turnings or borings to the cupola charge, but the efficacy of the expedient is not universally accepted.

342. The strength of castings does not depend entirely upon the excellency of the mixture, or of the brands of iron employed in the production of the castings, but much also is to be referred to the design of the casting, with respect to its general outlines or conformation, considered with regard to the influence of its form upon the arrangement of the crystals of the metal when it changes from the liquid to the solid state. Crystals of cast-iron arrange themselves with their principal axes perpendicular to the boundary planes of the casting, or, in other words, the planes of crystallisation are grouped perpendicular to the external contour of the casting, and the lines of junction of these groups of planes of crystallisation are lines of weakness in the casting. Sudden and great alterations in the thickness of the metal in adjacent parts of the same castings are for similar reasons also

highly injurious. Fig. 32 shows the arrangement of the crystals in the simplest form of casting—viz., in a square plate, where the diagonal lines of weakness extending across the plate from corner to corner are shown; but the particular crystalline structure developed in the casting depends upon the quality of the metal employed, and the rapidity with which the casting operation is performed.

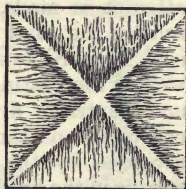

Fig. 32. — Arrangement of Crystals in a Square Flat Plate of Cast-iron.

343. Large flat plates, especially if thin, also frequently buckle and sometimes fracture themselves during cooling; and to prevent this, if the plate be an open casting, it is the practice immediately the casting has been run to throw sand over the surface of the solidified metal, and then remove the same from the surface along two diagonal strips or bands corresponding to the lines of weakness shown in Fig. 32. This has the effect of cooling the central portions (which would otherwise remain hot for the longest period), and so facilitates the uniform crystallisation of the several parts of the plate, and at the same time prevents as much as possible the formation of lines of weakness arising from unequal rates of cooling in the several parts. In like manner, efforts are made in the same direction to avert destructive changes on the solidification and cooling of the castings made in closed moulds or boxes, but it then requires more care and judgment, since in removing one portion of the moulding-box from another, it often becomes impossible to prevent the exposure and cooling of some portion of the casting, which ought to be kept hot as long as possible to prevent the development of destructive lines of weakness; and so various devices are adopted in the foundry of removing by the spade the sand around the thicker portions of a casting, so as to facilitate the

cooling of such parts more rapidly than the thinner but more protected portions. In such articles as cast-iron girders, machine or engine bed-plates, &c., of considerable depth, and having thick flanges on one edge, an attempt is made, as soon as the metal has solidified, to remove the sand from around the thick flange, and so cool it more rapidly than the thinner upper flange or web of the casting: otherwise the upper thin edge cools and contracts first, then the lower edge subsequently contracts, and the casting is bent or buckled accordingly, attended by the development of undue and unknown strains in the finished casting; but if the plan above noted be successfully carried out, the two edges are cooled more nearly together and these strains are avoided.

344. Sudden or abrupt changes in the form or thickness of a casting are for like reasons to be avoided, since along

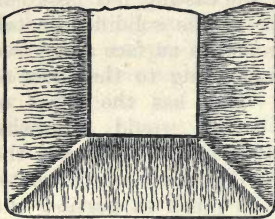

Fig. 33.—Crystallisation in a Square-ended Cast-iron Cylinder.

the line of junction of a thicker and thinner portion of a casting will be a plane of weakness coinciding with the plane towards which the principal axes of crystallisation in the two parts are directed; whereas if the change be not abrupt, but pass gradually from the thin to the thick portion, or if instead of a sudden

angular change of form the curved form be adopted, then the principal axes of crystallisation no longer assume a straight line, but take a curved line, and their destructive tendency is mitigated. Fig. 33 shows the weak square angle, and Fig. 34 the stronger circular or curved end, as applied to the closed end of a cylinder or other similar casting.

345. Some judgment is also required in *running the metal from the ladle* into the sand-mould prepared for its reception, so as to produce the soundest, strongest, and

best casting, without *cold-shorts*, *blow-holes*, or mechanically-enclosed impurities. Thus, whilst hot metal and quick running produce castings freer from cold-shorts and mechanically-mixed impurities than dull cold metal and slow running, yet with heavy castings the crystallisation of the metal in the casting is larger, and therefore the strength of the casting is reduced, and its fracture is also coarser when hot metal is employed ; so that whilst hot metal and quick running are desirable for light, ornamental, and hollow work, yet for heavy castings the lower the temperature at which the metal is poured—provided

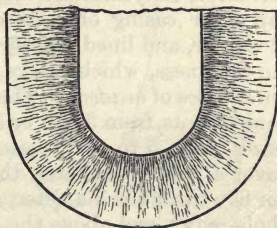

Fig. 34.—Crystallisation in Circular-ended Cast-iron Cylinder.

it retains sufficient fluidity to prevent cold-shorts, and to fill up accurately every cavity in the mould—the closer will be the grain and the denser the metal, fewer of the injurious planes of weakness will occur, and consequently the casting will be stronger.

346. The furnaces employed in melting the cast-iron for the foundry are of either the *cupola* or *reverberatory* type, of which the former is the more generally adopted. The *reverberatory furnace* is only employed where blast is not easily obtainable, where larger quantities of metal are required at the same time than can be conveniently melted in the cupola, or where superior strength and cleanliness of metal, as in gun-founding and the like, are of paramount importance ; whilst the *cupola* melts cheaper than any other furnace, and it can be used for melting any weight of charge, from half a hundredweight to five or six tons ; and although coke is the usual fuel employed, especially where a semi-bituminous coal is cheap and abundant, yet where anthracite coal is more abundant, as in the United States, this fuel can be employed ; and charcoal is also available, although very seldom used.

Since the construction and working of the reverberatory furnaces for melting pig-iron do not differ from the usual reverberatory type of furnace, it will not be necessary to further refer to them.

347. The **Foundry Cupola Furnace**, as usually constructed, is cylindrical in cross-section, and is formed of an outer casing of cast- or wrought-iron plates riveted together, and lined with fire-brick of not less than 9 inches in thickness, which bricks are set in fire-clay and all laid in courses of *headers*. The cupola is built according to requirements, from 2 to 4 or 5 feet in diameter, and, for small sizes, from 5 to 6 diameters in height; but for cupolas over 4 feet in diameter the height does not exceed four or five times the diameter, as measured up to the charging-hole only; and above the charging-hole is fixed a conical sheet-iron hood or chimney. The furnace is built upon a base plate or ring of cast-iron, resting either upon a foundation of brickwork, or carried upon cast-iron columns; and in the latter case the bottom may be closed by a falling door, beneath which can be run a trolley to receive the residual coke, slag, &c., after the melting is completed, instead of raking the same out through the breast-opening, as will be presently described. In front of the cupola, and level with the bottom, is an opening (Fig. 35), or *breast-hole*, *b*, about 2 feet square, which is closed when the cupola is in blast by a wrought-iron plate, secured by a bar placed across its face and wedged into two lugs on the body of the cupola. In the lower edge of the breast-plate is cut a hole 4 or 5 inches in width and 6 or 7 inches in length, in which is placed the *tapping-hole* employed for tapping out the metal into the hand-ladles or shanks used in casting light work; whilst at a corresponding point, but on the opposite side of the cupola is fixed a spout and second tapping-hole, which is employed when the furnace is tapped into the larger ladle required for heavier castings. Blast is introduced into the cupola from the belt, *d*, by twyers, *c*, placed around the circumference; the belt, *d*, encircles the furnace

and communicates with the blast-main leading from the blower, fan, or other blowing engine, by one or two vertical pipes (according to the size of the cupola); or, when the belt, *d*, is not fitted to the cupola, then each twyer is connected by a vertical pipe with the blast-main. The twyers vary in number with the size of the cupola. With a cupola 1 foot 6 inches (1' 6") in diameter, using charcoal as fuel, one twyer is sufficient; but with one of 2 feet in diameter, two twyers become necessary; whilst a 4-foot cupola requires four twyers. In the elbow of each twyer there is a sight-hole, *h, h*, closed by a movable door fitted with a glass plate, through which the workman can observe the progress of the melting, and by opening the door can introduce a bar as may be necessary to potter down any scaffolding or tendency of cold coke and slag to collect in their neighbourhood.

348. The *hearth*, or bottom, of the cupola, is prepared by well ramming a layer of about six inches in depth of sand, to which the required consistency has been given by the addition of a little wet loam. The bottom is made hollow towards the centre, and slopes from all parts towards the tap-hole or spout, over the bottom and sides of which the coating of loamy sand is continued. At a convenient height below the edge of the charging-hole, *B*, is fixed the *charging platform*, which should be sufficiently large to admit of the pig-iron, scrap, coke, and limestone required for the charge to be at once

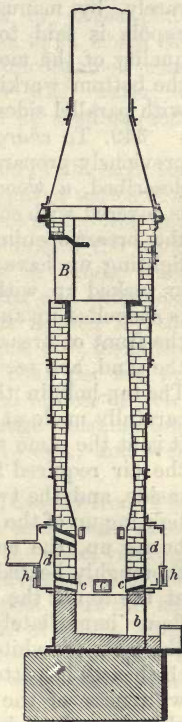

Fig. 35.—Sectional Elevation of Foundry Cupola.

stacked ; and these materials are usually elevated to the required level by steam or hydraulic lifts, or, more rarely, by manual labour. The internal form of the cupola is said to have an effect upon the working and quality of the metal—a cupola wider at the top than at the bottom working hotter and lasting longer than one with parallel sides.

349. To *charge the cupola*, the bottom having been previously prepared with loamy sand in the manner just described, a wood fire is lighted thereon, and the same is covered with coke, coal, or charcoal, introduced through the breast-opening. When the necessary materials for lighting up have been introduced, the breast is closed or tucked up with coke, and a quantity of loamy sand is shovelled up and tightly rammed against it, after which the front or breast-plate is placed in position in front of the sand, and secured there by the bar across its face. The tap-hole in the lower edge of the breast having been carefully made at the level of the shoot or spout outside, it is at the same time kept full open for the admission of the air required for the combustion of the burning fuel inside, and the twyers are likewise left open during the lighting up of the cupola for the like reason. As the fire burns up, the cupola is filled up with fuel, and when thoroughly heated, as indicated by the flame appearing at the top of the coke, the blast is admitted and a blue flame immediately issues from the tap-hole, the flame changing to white as the cupola becomes hotter. When the hearth has attained to a white-heat, as indicated by the whiteness of the flame issuing from the tap-hole, the charging of pig-iron, fuel, and limestone is commenced ; and when the metal begins to melt and flow downwards the tap-hole is closed by a stopper of loam or clay, introduced in the ordinary manner upon the end of a staff or rod of iron. Coke, pig-iron, and limestone are added in the order named, keeping the cupola quite full as the charge sinks. In this manner the whole weight of metal required is charged into the cupola while the molten

metal collects in the hearth, and is tapped out as is necessary during the melting process. The blast is kept on until the whole of the metal has been tapped out, when it is shut off, and the apron or breast-plate removed from the breast of the furnace, upon which the sand-breast is broken away and the unconsumed coke with slag is raked out and quenched with water, a portion being returned to the furnace at a subsequent charge.

350. About $2\frac{1}{2}$ cwt. of coke is added with each ton of pig-iron ; but the quantity of fuel required varies with the construction of the cupola, the nature of the iron and quality of the fuel, the strength and volume of the blast, and especially upon the class of work in hand ; since light, hollow ware requires hotter metal and consumes considerably more fuel per ton than is needed for the production of large heavy castings. Thus, also, hæmatite and cold-blast pig-irons require more coke per ton for their fusion than do Scotch or Cleveland brands of iron ; and although $2\frac{1}{2}$ cwt. is about the average consumption, yet, under more favourable conditions, $1\frac{1}{2}$ cwt., and even less, suffices to melt a ton of pig-iron.

351. After the first charge of metal, usually from 2 to 5 per cent. of *limestone* is added, which acts as a flux to the earthy matters of the metal and of the coke, yielding with them a fusible slag which floats on the surface of the molten metal in the hearth of the cupola ; but the addition of limestone demands the exercise of a little judgment, since too much, as also too little, produces a whiter, weaker, and harder metal than when the normal quantity only is added.

352. The blast for the cupola must be sufficient in quantity and pressure to ensure the perfect combustion of the fuel with sufficient rapidity to produce the intensity of heat required for the melting of pig-iron ; for it is obvious that if the blast be soft and weak, although the fuel may be completely consumed, its combustion will be effected more slowly, and the cupola may not attain the intensity

of heat necessary to melt the pig with the required rapidity; and the metal is from this cause at the same time deteriorated in quality, runs thick and pasty, and yields inferior castings; whilst, again, if the blast be too strong, it blows away a considerable quantity of unburnt fuel, and either extreme therefore involves a serious loss of fuel. The amount and pressure of blast differ with the size and construction of the cupola; but with the usual cupola melting about 4 tons of metal per hour, from 1,200 to 1,500 cubic feet of air per minute, at a pressure of 12 oz. to the square inch, is required; and it should always be as free as possible from moisture, and delivered into the cupola above the surface of the molten metal.

353. For foundry purposes, the blast is usually supplied by fans, blowers, or blast-cylinders, each of which has its advocates. Fans and blowers are, however, less expensive to put down in the first instance, and are more economical in repairs, although requiring a little

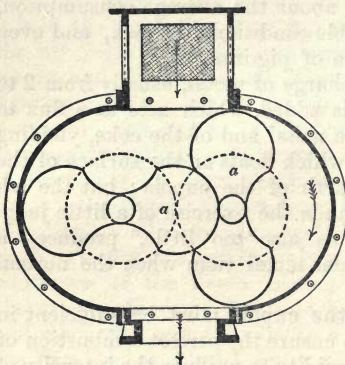

Fig. 36.—Transverse Section of the Roots Blower.

more power than blowing-engines; but the latter give a more constant and regular blast. The more generally applied blowing apparatus for foundry purposes are fans of the type of Lloyd, Schiele, Baker, &c., whilst the Roots Blower is also extensively used.

354. The Roots blower consists of an iron casing in which are placed a pair of revolving wafers, *a, a*, either of cast-iron as shown, or built up of a wood-lagging bolted to a skeleton iron framework. These wafers are driven by

belts off pulleys, make from 300 to 400 revolutions per minute, and leave the smallest possible clearance between their two curved surfaces as they revolve. The surfaces of the wafers are further lubricated and kept smooth by painting them at intervals with a compound formed by melting together in definite proportions a mixture of tallow, plaster of Paris, beeswax, and a little black-lead. The other details of construction, direction of blast, and mode of working, are indicated with sufficient clearness in Fig. 36 to render further description unnecessary.

355. For the production of heavy castings of, say, 5 tons and upwards in weight with one cupola only for melting the iron, the usual procedure is first to melt 30 cwts. or 2 tons of metal, and then tap it out into the ladle, after which the tapping-hole is closed and the blast again put on, allowing the melted metal to again collect to a like amount in the hearth of the cupola; this occurs in about thirty minutes, when the blast is again turned off, and the molten metal tapped into the same ladle as before. The melting is resumed once more, and the process is repeated some four or five times, or until the total weight required has been, by successive tappings, collected into the same or two separate ladles according to their capacity. The surface of the metal in the ladle is covered between each tapping with about one inch of charcoal dust, so as to preserve the heat in the metal as long as possible. In this manner, although the metal first tapped from the cupola may have been standing in the ladle for upwards of three hours, yet the excess of heat in each successive tapping of hot metal is usually enough to maintain the whole at the sufficiently high temperature and state of fluidity required for the production of large heavy castings; for, as previously noted, it is not desirable to cast such large masses at nearly the same temperature as is employed for light or small work. There is, however, a limit to this intermittent process of stopping to tap and then resuming the melting, inasmuch as the quantity of slag is

constantly increasing in the cupola, and as it becomes excessive the slag-hole must be kept open that it may be blown out. This is attended with a loss of pressure of blast and a decreased rate of melting, until the slowness of melting exceeds the time during which the metal can be safely kept standing in the ladle, the consumption of fuel is also unduly increased, and the metal becomes unnecessarily dirty.

356. The sand in which the molten metal is run for the production of castings of cast-iron, must possess sufficient cohesiveness to receive accurately and to retain the form made in it from the patterns, whilst it permits also of being rammed up sufficiently hard to resist the pressure of the liquid metal, and prevent the permeation of the latter through it; but at the same time it allows of the free escape of the gases, given out from the metal, the sand, and the blacking with which the mould is coated. Further, the sand should not be affected chemically, nor suffer fusion by contact with the heated metal, and should, moreover, give a clean, sharp, smooth surface to the casting, and beyond these qualities it must also readily part itself from the body of the casting after cooling. Such sands are more generally found in the Coal Measures, or in the New Red Sandstone of Derbyshire, Lancashire, Cheshire, and Shropshire; but good moulding sands also occur in the North of Ireland, in Lanarkshire, and in the London Basin. For foundry use it is mixed with from 7 to 10 per cent. of *coal-dust*, and the mixture is always slightly damped before use. After the casting is withdrawn from the mould, the sand in contact with the metal is found to have lost a certain proportion of its carbonaceous or coaly matter, when it is technically spoken of as being "burnt," and the worst portions are then thrown away, whilst the remainder is turned over with the spade, re-moistened with water, and, after the addition of a further small proportion of *coal-dust*, is again available for the moulder. When the casting is made directly in the sand mould without any

drying of the mould, the casting is described as being in *green-sand*; but if, after the mould is prepared, it is thoroughly dried in the stove before running the metal into it, then the casting is spoken of as a *dry-sand casting*.

357. **Loam**, as already noted, is a special variety of calcareous or ferruginous clay containing sand, which latter ingredient when not occurring in sufficient quantity in the clay, may be mixed artificially to the required extent. But to give to the loam the porosity necessary in a moulding material for the body of the mould, it is usual to add also powdered coke with horse-dung, or for the last-mentioned may be substituted straw, chaff, chopped tow, plasterer's hair, or other binding material; but the loam employed for facing the mould wherever it comes into contact with the metal consists only of the clay and sand, without other admixture.

358. Castings are described as **green-sand, dry-sand, or loam castings**, according to the method pursued in the preparation of the mould into which the metal is run. In *green-sand moulds*, the sand is used quite fresh and damp, the dampness being often further increased by the workman during the process of preparing the mould; and for the preparation of moulds in green-sand, wood or iron patterns of the articles to be made are universally used. For moulding in *dry-sand*, patterns are also most frequently though not invariably required, and the sand employed is usually the pit-sand (loam that has already been used in loam-moulding), along with an addition of rock-sand; and the moulds, after being prepared in such sand, are always carefully dried in suitable stoves, to fit them for receiving the molten metal. In *loam castings*, the mould is built up of brick-work, which is then faced with the wet loam just described (§ 357), and afterwards blackened; such moulds also require to be well dried before using. The usual patterns are not generally employed in loam-moulding, the articles ordinarily cast in loam being sugar-pans, cylinders, and other circular symmetrical ware that can be formed

by the use of a strickle, or loam-board, revolving upon a fixed pivot, or centre, with loose patterns for projecting portions only.

359. Besides the method of casting in green-sand, dry-sand, and in loam, it often becomes desirable to produce a casting in iron, which shall possess a wearing surface or outer skin of extreme hardness, partaking of the nature of hardened steel, whilst the general body shall retain the soft and usual character of a casting in grey or mottled iron. Such castings are known as *chilled castings*, and instead of being cast in sand or loam in the ordinary manner, are cast either wholly in a metallic

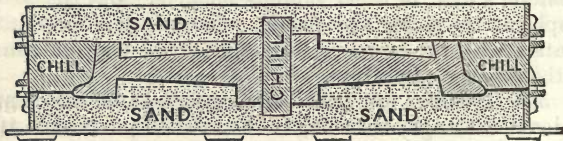

Fig. 37.—Section of Mould for Chilling Tread of Wheel.

(cast-iron) mould, if the casting is to be entirely chilled ; or in a mould made partly of sand, with a chill or cast-iron portion only where the hardening is to be effected. Thus the hole through the bosses of wheels for trams, trolleys, &c., are chilled on their inner or bearing surfaces by the introduction into the mould of a steel pin or chill in lieu of the ordinary loam core. The tread or rim of a wheel is chilled in like manner by making the mould in parts, of which the portion (Fig. 37) in contact with the rim is made of cast-iron, whilst the arms and boss of the wheel are moulded in sand in the usual way. The fluid metal in contact with the metallic parts of the mould is thus cooled and solidified more rapidly than the body of the casting, and a much smaller proportion of graphitic carbon is found in the metal for a certain depth from the face of the chill-mould, producing thereby a whiter and harder metal than occurs in the body of the casting made in contact with the sand of the mould.

360. Certain mixtures of iron answer much better than others for chill-castings, and the exact mixtures employed by the better founders are often considered as trade secrets, but mixtures in which the pig-irons contain a considerable proportion of their carbon in the combined state, and which yield a strong, tough, fine-grained bright grey, or grey mottled fracture in the pig, are best suited for the purpose; whilst if the pig-iron contains a little manganese the chill is deeper, and for this purpose a little spiegeleisen is frequently added to the furnace charge. It may be noted that No. 1 dark-grey iron is quite unsuitable for the production of chilled castings, although it is impossible to predetermine from the chemical analysis of any pig-iron whether it will produce good chill-castings or otherwise. A mixture employed for casting chilled rolls consists of equal parts of mottled hæmatite, of No. 5 strong hæmatite, and of Blaenavon or Pontypool cold-blast pig-irons. Others for the same purpose use Lilleshall cold-blast with white Cleator and No. 5 hæmatite, with selected scrap. Other mixtures for special work, again, consist largely of Madeley wood or Cwmbran pig-iron.

361. *The chills* employed in the production of chilled castings are usually about three times the weight of the casting to be made within them, since, if the mould be too light, it is apt to soften and stick to the casting, while the heat is not carried away with sufficient rapidity to produce the desired degree and depth of chilling; but the *minimum* thickness possessing the necessary strength and capacity to chill a suitable mixture of pig-iron, such as noted above, appears to be attained when the mould is of about the same thickness or weight as the metal to be chilled. As already stated, however, on account of the great wear, &c., on chill-moulds, the practice is to make them considerably heavier than this minimum indicates, although an excess of thickness in the mould produces little, if any, increase in the depth of the chill beyond that produced by a mould of the minimum thickness

just mentioned. The chill-moulds are made of a good, strong, mottled iron, sound and smooth after boring, machining, and treating as described in the following sections.

362. The metal for chilled castings is run much hotter and more rapidly than with ordinary sand castings, and it hence becomes necessary that the moulds be perfectly free from moisture, and it is thus usual to well warm all chill-moulds before casting in them. Clay wash cannot therefore be applied to them, but often a thin coating of black-lead and oil, or black-lead alone, is put on with a brush.

363. The preparation of the chills or moulds is somewhat costly, since it is desirable wherever possible to turn, bore, or machine all parts of the mould coming into contact with the fluid metal, and such surfaces are afterwards rusted by wetting them during three or four days with dilute hydrochloric acid or urine, the rust so formed being, however, removed by careful rubbing previous to placing it in the mould; but a better and smoother surface, less liable to stick, is obtained by this preliminary treatment.

364. There is less difference between the size of a chilled casting and the pattern from which it is made, than exists with a sand casting; greater care is also necessary in withdrawing chilled castings from the mould, for with a casting chilled on its external surface or circumference such as a wheel, cylinder, or the like, it is obvious that on first teeming the metal into the mould the outer skin in contact with the chill solidifies first, the heat being more rapidly conducted away from the fluid metal by the metallic chill than in the portions surrounded by sand, and the casting thus solidified at the surface contracts from the mould on its exterior, whilst the mould itself is at the same time becoming hotter and expanding, so that the casting thus becomes loose in the mould, rendering it desirable to withdraw the same as soon as the body is sufficiently solidified to bear removal without fracture or

distortion of its shape ; otherwise when the mould begins to cool it is apt to contract upon the casting and so fasten the same in the mould. In like manner, if the chill be on an interior surface of the casting, as in chilling the hole through the bosses of wheels, the metallic pin employed in chilling the part is often knocked out as soon as the metal is sufficiently solidified, and before the expansion of the pin and contraction of the casting have become sufficient either to fix the pin tightly, or, as frequently happens, to fracture the casting by its contraction upon the resisting metallic core. It is evident that the sudden cooling of one part of a casting more rapidly than another, has a tendency to introduce internal disruptive strains, and it is therefore desirable to carefully anneal chilled castings immediately they are withdrawn from the mould and before they have become cold.

365. **Gates** are the names applied to the one or more openings or channels that are made in either green-sand, dry-sand, loam, or in chill-moulds for running the metal into such closed moulds, or for taking away the gases liberated by the heat of the liquid metal as it flows into the mould, and of the air displaced from it. According to their purpose the gates receive distinctive names ; thus, the one or more openings into which the metal is first run are called *pouring gates*, the recess below each of which for the skimming of the metal is known as the *skimming gate*, whilst the smaller passages, often two or three in number, leading from the skimming gate to the mould are called *sprues* or *sprue gates* ; and, again, the small openings through which the workman keeps up a supply of iron to the interior of the castings, by constantly moving a rod up and down during the cooling and solidification of them, especially if large in size, are called *feeding gates* ; whilst, lastly, there are also *flow gates* through which the metal rises when the mould is filled up with cast-iron. These last are plugged up with clay balls until the mould is judged to be nearly filled with metal,

when they are withdrawn, and by the ascent of the metal through them the workman knows that the mould is quite full. If the clay plugs just mentioned are omitted, the air escapes too freely from the mould, and the sand on the bottom is liable to be washed up by the flowing in of the fluid metal.

366. It is impracticable, within the limits of this volume, to describe the construction and requirements of cores, patterns, &c., the varieties and purposes of the numerous forms of moulding-boxes and core-barrels, or the details of the manipulation required for moulding in green-sand, dry-sand, or loam respectively, or yet to give any useful description of the types of cranes, ladles, stoves, &c., occurring in every well-appointed foundry.

CHAPTER X.

MALLEABLE OR WROUGHT IRON.

367. MALLEABLE, wrought, or bar iron, under which names the same metallurgical product is known, was formerly described as iron in its lowest degree of carburisation; but with the advance which has happened in late years in the manufacture of steel, all attempts to frame a definition of malleable iron upon a chemical basis have been futile, since in its low percentage of carbon, comparative freedom from such impurities as silicon, sulphur, phosphorus, &c., occurring so largely in pig-iron, it is rivalled or even excelled by the mild steels produced by the Siemens and the Bessemer processes. Definitions based upon its mechanical qualities are also equally unsuccessful, for the superior qualities of malleability, tensile strength, ductility, and welding, which, until a comparatively recent date, were considered to be the special attributes

of malleable iron, are all possessed in an equal or superior degree by the mild steels now produced in such large quantities, and with the utmost uniformity and regularity, by the processes above-mentioned. (See the table of tensile strengths of steel given on p. 397.) Thus, the only definition which appears to the author to be permissible is one based upon the mode of the production of the iron, according to which the terms malleable or wrought would embrace the commercial varieties obtained either as the result of the *decarburisation and more or less complete separation of several of the impurities of pig-iron during the process of puddling*, or, as the product of the direct treatment of certain ores in the Catalan, Bloomery, Siemens rotary, or other furnace, in which a *semi-fused product* is obtained possessing the malleability of wrought-iron. And the term *steel*, embracing also what is known sometimes as *ingot-iron*, would be reserved to distinguish such varieties of iron as are delivered in a state of fusion, allowing of the metal being cast at once into a *malleable ingot* from the furnace, crucible, or other vessel in which it has been produced.

368. Bar, wrought, or malleable iron, as manufactured by the puddling, Catalan, or other process, has a dull-bluish or blackish-grey colour, varying somewhat with its previous mechanical treatment, as to hammering, rolling, &c. Its fracture after hammering or rolling is of a fibrous character in the softer varieties, but becomes granular or crystalline in the harder kinds, and after simple fusion the metal always yields a decidedly crystalline or granular fracture. The higher qualities of bar-iron present when broken a certain silky fibrous appearance, which under repeated and long-continued vibration again assume a granular or crystalline structure. The fractured surfaces are, however, more or less deceptive, since specimens broken by progressively increasing stresses are invariably fibrous, whilst the same specimen if broken by a sudden blow will

exhibit a crystalline fracture. Wrought-iron is one of the most malleable, tenacious, and ductile of the metals, its malleability increasing with the temperature, short of fusion, to which it is heated. Sheets have been exhibited at Paris $\frac{1}{770}$ th of an inch in thickness, and at Pittsburg, according to report, they have been produced $\frac{1}{15500}$ th of an inch in thickness. Malleable iron is soft, but is exceeded in this respect by pure iron, and it is not altered as regards softness by being heated to redness and suddenly cooled by plunging into water; but bars of iron which have been so heated and suddenly cooled are shorter than the original bars. Iron may be magnetised by bringing it into contact with a magnet, or by placing it at a short distance from one, but it loses its magnetism on the removal of the exciting cause. Wrought-iron is infusible except at very high temperatures, its melting-point being given by Pouillet as between $1,500^{\circ}$ C. ($2,732^{\circ}$ Fahr.) and $1,600^{\circ}$ C. ($2,912^{\circ}$ Fahr.), while Scheerer gives it as $2,100^{\circ}$ C. ($3,812^{\circ}$ Fahr.), but its melting-point varies with the degree of its carburisation and its freedom from such elements as sulphur, silicon, phosphorus, manganese, &c., for the higher its content of carbon the lower does its melting-point become. The presence of sulphur, silicon, and phosphorus also lowers its fusing-point, whilst manganese, chromium, and tungsten raise its melting-point. When heated to whiteness, but before fusion occurs, it passes through a soft, pasty, amorphous condition, in which, if two clean surfaces be brought into contact and moderate pressure applied, as by hammering, squeezing, or the like, the particles cohere or *weld* together perfectly (*see* Welding, p. 7), while at a red heat it is possible to hammer or forge the metal into almost any form.

369. Malleable iron usually contains from only traces to 0.25 per cent. of carbon, but occasionally the carbon reaches 0.3 per cent., and although it is often described as the least highly carburised of the commercial varieties of iron, yet the latter figures indicate a material decidedly steely in character, for mild steel containing only from

0·10 to 0·15 per cent. of carbon is now an every-day production ; but the freer the metal is from such elements as silicon, sulphur, and phosphorus, the more carbon it can contain without presenting what are usually described as steely qualities. The specific gravity of malleable iron varies between 7·3 and 7·9, average specimens being about 7·6 or 7·7 ; its linear expansion by heat is about ·000111 to ·000126 of its length for each increase of one degree Centigrade, in which respect it thus stands lower than most of the metals, as is also the case with its cubical expansion or dilatation by heat. Its specific heat is given as ·114, water being taken as unity.

ANALYSES OF BAR, WROUGHT, OR MALLEABLE IRON.

	K.B.W. Best bar iron (Pattinson).	Swedish OO (Author).	Low Moor Armour plate (Tookey).	Round bar, W. R. 3 (Downar).	Armour plate (Percy).
Carbon . . .	trace	0·075	0·016	0·180	0·230
Silicon . . .	0·170	0·114	0·122	0·019	0·014
Sulphur . . .	0·028	0·032	0·104	0·014	0·190
Phosphorus . . .	0·200	0·004	0·106	0·074	0·020
Manganese . . .	0·140	trace	0·280	trace	0·110
Iron . . .	99·115	99·733	99·372	99·704	—
	99·653	99·958	100·000	99·991	—

370. Malleable iron may be exposed indefinitely, at the ordinary temperatures, to the action of dry air or even oxygen, without suffering oxidation ; but in the presence also of the vapour of water the metal is rapidly tarnished or rusted, a process still more active if carbonic anhydride be also present, as is usually the case in the atmosphere (*see Rust*, p. 42), when the corrosion is not confined to the surface, but extends throughout the mass if it be exposed sufficiently long to the oxidising influence. When, however, the metal is heated to redness and ex-

posed to the air, then oxidation proceeds very rapidly with the production of a black oxide of iron or *forge-scale*, which scales off from the bar when it is struck by the hammer. Heated to whiteness, malleable iron burns, throwing off scintillations from its surface, whilst the iron so heated in contact with the air becomes unweldable and friable, constituting what is known as *burnt iron*, a condition variously ascribed to an absence of carbon in the metal after such treatment, or to the presence of an excess of the oxides of iron throughout the mass. Continued hammering of malleable iron in the cold state induces a hard, brittle, and more or less crystalline condition in the metal.

371. Malleable iron combines readily with carbon when heated in contact with pure charcoal, coal, carbonaceous matters, or cyanogen compounds to a temperature at or above redness, as exemplified in the case of the manufacture of cement or blister steel, as also by the operation of case-hardening, where articles of malleable iron are heated in contact with leather cuttings, or cyanogen compounds (potassic ferrocyanide). Further, solid and gaseous cyanides, and nearly all vapours and gases containing carbon, such as carbonic oxide and the various hydrocarbon vapours, impart carbon to iron when the latter is exposed at a red-heat for a considerable time to their action; and in each of the above instances of the carburisation of malleable iron the process proceeds from the surface towards the centre of the bar, until, if the operation be continued sufficiently long, the carburisation will be extended quite through the whole mass of the exposed iron. Malleable iron is attacked by hydrochloric acid with the evolution of hydrogen and the production of ferrous chloride FeCl_2 ; concentrated sulphuric acid also slowly dissolves iron yielding sulphurous anhydride (SO_2) and a solution of ferrous sulphate, and the dilute acid also attacks iron, but with the liberation of hydrogen; while, when treated with ordinary nitric acid, nitrous fumes are copiously evolved, but if the acid be very

dilute, the iron is dissolved with the production of ferrous and ammoniac nitrates without any apparent escape of gas.

372. *Red-shortness* or unforgeability at a red-heat is induced in malleable iron by the presence of either *sulphur* or *copper*, 0.03 per cent. of sulphur producing a red-short, brittle, and unforgeable metal, and a like result is produced by the presence of 0.5 per cent. of copper, whilst but 0.028 per cent. of copper suffices to impair the tenacity of the metal. On the other hand, *cold-shortness* or brittleness at ordinary temperatures is induced by the presence of small proportions of *phosphorus*, *antimony*, *tin*, or *arsenic*, although the same metal may be quite malleable and ductile at or above a red-heat. Karsten observes that the presence up to 0.3 per cent. of phosphorus produces an increased hardness without affecting the tenacity of the iron, while with 0.5 per cent. of phosphorus there is a decrease in tenacity, and it becomes also cold-short, or incapable of being worked in the cold state without cracking at the edges, although when hot such a metal can be either rolled or hammered out readily. With 0.75 per cent. of phosphorus the cold-shortness is very decided, as is also the loss of tenacity, while when the proportion of phosphorus attains to 1 per cent. the iron becomes exceedingly cold-short. Eggertz, however, states that 0.25 per cent. of phosphorus in malleable iron renders it sensibly cold-short. Doubtless the influence of small quantities of phosphorus upon the working qualities of wrought-iron is affected by the amount of such other elements as silicon and carbon present. The late Mr. A. L. Holley, C.E., was of opinion that 0.2 per cent. of phosphorus is not injurious, but, on the contrary, improves the malleable iron if it be accompanied by 0.15 per cent. of silicon and 0.03 per cent. of carbon.

373. *Silicon* induces hardness and brittleness in wrought-iron, 0.35 per cent. sufficing to render the iron cold-short and low in tensile strength, but, owing to the facility with which silicon is oxidised and removed

in the slag during the puddling process, it is but rarely present in sufficient quantity to affect its quality, except in the form of silica as a constituent of the cinder often mechanically distributed more or less throughout wrought-iron.

374. *Tin* also hardens malleable iron, but produces likewise a brittle, unweldable, and cold-short metal.

375. *Zinc* alloys well with iron, as instanced in the galvanising process. (See p. 59.)

376. *Titanium*, occasionally found in pig-iron, does not appear to pass into the malleable iron produced from such pig.

377. *Antimony*, as already noticed, produces, when present in small quantities in malleable iron, a metal which is both cold-short and red-short.

378. The tensile strength of malleable iron ranges between 17 and 26 tons per square inch of section, but the average of the best qualities may be taken at from 22 to 24 tons, and the latter will stretch before fracture 35 or 40 per cent. of its length, in a test-piece of 2 inches in length and of $\frac{1}{2}$ inch sectional area. Special qualities of Bowling and Lowmoor iron give a tensile strength of 27 tons to the square inch, and a ductility or elongation represented by 38 per cent. in a test-piece of 2 inches in length, whilst best Staffordshire iron of 24 tons tensile strength affords an elongation of 30 per cent. in a test-piece 2 inches long. It becomes necessary, in considering the percentage of extension before fracture, to note the length of test-piece employed, for with a longer test-piece the percentage of elongation will appear proportionately reduced, since the greater portion of the extension is distributed over only a very short length of the test-piece, and thus the elongation of Staffordshire iron, given as 30 per cent. above, would not exceed about 20 per cent. if the test-piece were of the now more usual length of 8 inches, instead of 2 inches, as quoted above. The tensile strength of iron plates varies as much as 20 per

cent. in the same plate, according as the test-piece is taken lengthwise—*i.e.*, in the direction of greatest longitudinal extension, and therefore of development of fibre during rolling—or is cut crosswise from the plate; for whilst the test cut longitudinally may have a tensile strength of from 20 to 24 tons per square inch, the piece cut crosswise will break with from 18 to 22 tons; and thus the Admiralty require in first-class B B plates that they shall have a tensile strength of 22 tons per square inch along the length of the plate, with 18 tons to the square inch in a test-piece cut crosswise of the plate, besides which certain forge tests are specified, and all plates are to be free from lamination and surface defects. Wire-drawing, as already mentioned (p. 4), very materially increases the tensile strength of iron.

379. Upon the differences in mechanical treatment of hammering, piling, welding, and rolling which the puddled ball has received after withdrawal from the puddling furnace principally depends the commercial classification of malleable iron into No. 1, No. 2, best or No. 3, best-best, and treble-best qualities or grades. Of these, No. 1, or *puddled bar*, represents the long flat bars, showing a rather rough surface, which are of a quality unfit for the smith's use but which are generally employed only for cutting up and piling, in the manner subsequently to be described, for the production of No. 2 and the higher qualities of bar iron. No. 1 is produced by the blooming of the puddled ball under the hammer or squeezer, and then passing the bloom so produced without re-heating through the grooves of the roughing and finishing rolls for the production of the required section, which varies with the use for which the bar is intended.

380. For the production of No. 2 or *merchant bars*, which is the lowest quality of bar iron available for the general smith's use, No. 1 or puddled bar is cut up at the shears into suitable lengths, and piled into oblong rectangular packets, which are then placed in a re-heating furnace where they are raised to a welding heat, and in that

state passed, either with or without previous hammering, through the several grooves in a train of rolls for the production of the desired section.

381. In the manufacture of No. 3, or *best iron*, the pile or packet is made in the same manner as for No. 2, except that the top and bottom bars or plates of the pile are formed of No. 2 iron instead of No. 1, or the whole pile may be formed of No. 2 cut up and piled in the same manner as for the production of merchant from puddled bar. The pile, as before, is raised to a welding heat, and then again passed through the rolls. This quality corresponds to the best Staffordshire iron often mentioned in engineers' specifications, and is better adapted to the requirements of the smith than either No. 1 or No. 2, owing to its superior toughness and ductility over the lower grades.

382. *Best-best* is a superior quality of bar iron, suitable for chains, anchors, rivets, &c., and is the result of the cutting up, piling, re-heating, and re-rolling of bars of No. 3 iron; while a further repetition of this process yields the *treble-best* iron of the iron-master.

383. *Nail rods* are the square bars used by nail-makers, &c., and are produced by cutting up the ordinary bars of the required thickness in the "slitting mill"; the latter consisting of a pair of rolls fitted with collars, either turned on the rolls themselves or supplied by loose discs fitted to them. The rolls revolve together so that the collars in one roll fall into the spaces between the collars of the other, thus forming a series of circular cutters which act as shears upon the plate or bar passed between the rolls, and so pay out at the back of the rolls a number of small rods or bars, instead of the single plate delivered into the rolls.

384. *Iron plates* in like manner result from the rolling of suitably piled bars, the white-hot pile being first passed through the grooves of the blooming rolls for the production of a square bloom, which is then passed through the roughing rolls, and finally through

the finishing rolls, the thickness of the bloom or plate being reduced at each successive passage between the rolls. The order of passage and mode of building up the pile for plates of various sizes will be subsequently referred to, as will also the mode of producing thinner plates or sheets. It is usual to describe all plates of a thickness below No. 4 B.W.G. (Birmingham Wire Gauge)— $\cdot 238$ inch—as “sheets,” whilst all above such a thickness are called “plates.” *Black plates* are the thin sheets intended for tinning, and which, during the process of rolling, are doubled over upon themselves after every re-heating. This doubling is performed in the case of very thin sheets so that sixteen thicknesses are being passed between the rolls at once, before the plates are cut up to their proper and finished sizes. Sheets so produced are classified as *singles*, if between No. 4 B.W.G. and No. 20 B.W.G. ($\cdot 238$ inch to $\cdot 035$ inch) in thickness; or as *doubles* if between No. 20 B.W.G. and No. 25 B.W.G. ($\cdot 035$ inch and $\cdot 020$ inch) in thickness; and as *trebles* or *lattens* if between No. 25 B.W.G. and No. 27 B.W.G. ($\cdot 020$ inch and $\cdot 016$ inch) in thickness.

CHAPTER XI.

THE PRODUCTION OF MALLEABLE IRON DIRECT FROM THE ORE.

385. MALLEABLE iron is produced either as the immediate result of the direct treatment of iron ores, or indirectly by first smelting the iron ore for the production of pig-iron, and then subsequently treating such pig-iron in the open hearth or reverberatory furnace for the production of malleable iron.

I. The methods for the production of wrought iron *direct from the ores* embrace the treatment of iron ores

in the Siemens Rotary Furnace ; by the Catalan process, as still practised to a small extent in the Pyrenees, India, Sardinia, Africa, and some parts of America ; and by the method of the American Bloomery Furnaces.

II. The methods for the production of malleable iron by the *indirect processes*, for the conversion of pig-iron into malleable iron, include—

(a) The treatment of pig-iron in the open hearth, as by the South Wales process ; in the Lancashire Hearth or Swedish Finery, and by the German Walloon process, the last-mentioned being, however, of rapidly diminishing importance ; and—

(b) The treatment of pig-iron in the reverberatory or *puddling furnace*, which process, unlike the other methods, is adapted to the production of malleable iron from inferior fuel and materials, and constitutes the method according to which by far the largest proportion of the malleable iron now manufactured is produced.

386. As above mentioned, the *direct processes* necessitate the use of purer and richer ores and fuels than the indirect processes ; since although ferric oxide is reduced at a red-heat by carbonic oxide, yet the reduced iron is then left mixed with the gangue of the ore ; but if the gangue be of a readily fusible nature, then the iron sponge produced by this reaction may be consolidated by hammering or squeezing into a comparatively solid bloom, and the scoriæ at the same time expelled. But readily fusible scoriæ permitting of being thus expelled can only be produced under the conditions prevailing in the direct processes (of heating iron ores to a comparatively low temperature in contact with carbonaceous matters) by operating upon the richer ores of iron, and extracting therefrom only a portion of the metal which they contain, and allowing the remainder of the iron to escape in combination with the silica and other impurities of the ore, for the production thereby of readily fusible silicates rich in iron. Under these circumstances the carbon does not combine

with the reduced iron in sufficient quantity to recarburise the same to the condition of pig-iron, and hence it only becomes necessary to expel the fusible slag of ferrous silicate, by hammering or otherwise compressing at a high temperature the metallic sponge so obtained, and there is produced a solid metallic mass or bloom corresponding to the puddled bloom of the indirect process of manufacture.

387. The Siemens direct process, employed to a limited extent in America, England, &c., is one of the latest processes for the direct extraction of malleable iron, or of a steely metal suitable for the open-hearth steel process, from rich hæmatite and magnetic iron ores. The furnace employed in this operation consists of a cylindrical rotating chamber, measuring about 10 feet 6 inches in diameter and 10 feet 6 inches in length, placed with its axis horizontal. The casing is of wrought-iron plates riveted together, and is lined with a refractory basic lining, consisting first of a single course of fire-brick on edge—that is, $3\frac{1}{2}$ inches in thickness—or, at the front and back ends—which are subject alike both to corrosion and to erosion by the revolving materials—the chamber is preferably lined along the line of the level of the charge with bauxite or magnesite bricks; over the fire-brick lining first mentioned is made a working or fettling surface of a basic coating some $2\frac{1}{2}$ inches thick, made by melting within the rotator a mixture of hammer scale and iron ores. At the back end of the rotating chamber is fixed a water-tank or jacket, through which a current of water is constantly circulated, so as to keep the ring at the back of the rotator cool; also for maintaining this circulation, as well as turning the charges over and over as the rotator revolves, there pass from the back to the front of the furnace four water-pipes, which are connected alternately with a valve at the centre of the front or working end of the rotator, and the water-jacket at the back. These pipes are placed beneath the fire-brick lining, and upon each of them within the rotator are fixed

two bends or knees, which stand above the general level of the lining, and so serve, as just mentioned, to turn over the charge as the furnace revolves, so as to continually expose fresh surfaces to the action of the flame, and also to break up the charge in the final stages into five or six balls, instead of collecting it into one unmanageable mass. Two rails, one near each end, encircle the body of the rotator, and these rest upon four friction wheels, carried upon two axles on an under-framework or carriage of wrought-iron girders, by which arrangement the chamber is free to revolve with only a small expenditure of power, and can be moved backwards or forwards horizontally for repair, &c. In the front end of the rotator are the slag-holes, and the working door, the latter being closed during the working of the furnace, and only opened either for the introduction or withdrawal of the charge. In the back end is a large circular opening, which is brought almost into contact with the circular throat, from the gas-producers and two regenerators with which the apparatus is supplied. The throat last mentioned is divided by brick partitions into three distinct flues, one of which serves to convey the gas direct from the gas-producers to the furnace, while the other two are in connection with the two regenerators, employed alternately for heating the air required for the combustion of the gas in the manner described on p. 375.

388. The velocity with which the gases from the producers and the heated air for their combustion enter the rotator, is sufficient to carry the flame quite to the front end, and thus to thoroughly and uniformly heat it before the products of combustion are drawn back by the chimney-draught through the same end of the rotator as that at which they entered, and from which point they pass through one of the regenerators on their way to the stack precisely in the manner more fully detailed in the case of the Siemens regenerative furnace (p. 371), with the exception that in the rotator there are only two sets of regenerators, instead of the four described

(p. 373); so that the waste gases on their way to the chimney pass through one regenerator only, and when this is sufficiently heated the air-valve is reversed, and the air then passes through the last-heated regenerator before entering the furnace for the combustion of the gases from the producers; while the waste gases, the products of combustion, and of the reactions involved in the reduction going on within the rotator, are then drawn towards the stack through the other or colder regenerator, so re-heating it; the reversal being effected as required for heating the regenerators alternately. Around the circumference of the rotator and at the centre of its length is fixed in segments a spur-wheel, gearing into a pinion which is connected with a train of gearing driven by a small steam-engine, and so arranged that, without alteration in the speed of the engine, but by the movement of a sliding clutch, a quick or slow speed can be imparted to the rotator, as required at different stages of the working of the process.

389. It is desirable that the inner or working surface of the rotator be not perfectly regular and uniform, otherwise the charge merely slides around as it revolves, without turning over fresh surfaces to the action of the flame, and to the reducing action of the furnace and fuel, and prolonging, therefore, the duration of the process. The uniform movement also renders it more difficult to ball up the reduced metal. To remedy these evils, the bends or elbows in the water-pipes already spoken of were introduced, and these, when covered over with the fettling of the furnace-lining, form irregularities which effectually prevent the charge from sliding, and turn it over for the more rapid reduction of the metal from the ore.

390. The ore for use in this process is reduced to the size of peas or beans, and occasionally a little lime or other fluxing material is added in sufficient quantity to yield a basic though fluid slag by its combination with the gangue of the ore, and only a small propor-

tion of ferrous oxide. When the chamber or rotator is fully heated, the charge of about 20 cwts. of ore, as above, with about 12 cwts. of roll or hammer-scale, and 6 cwts. of small, soft, free coal, or preferably of charcoal, all previously intimately mixed and elevated by a suitable apparatus to a hopper above and in front of the rotator, is then discharged by a shoot into the heated chamber through the door at the front end of the furnace; the door, at the time of charging, being placed on the top centre for the purpose of receiving the end of the shoot leading from the hopper in which the charge stands. The engine is now set to work, and the rotator revolved slowly. During the first hour the heat is sufficiently maintained with but little gas from the producers; but after this period the temperature is raised by the admission of larger quantities of gas and air, whilst the velocity of rotation is also increased, and a rapid decomposition ensues, owing to the reaction of the carbonaceous matters upon the ferric and magnetic oxides of the ore and scale respectively, whereby metallic spongy iron is separated and carbonic oxide is evolved, which latter combines with the heated air entering from the regenerators, and so assists in maintaining the temperature of the furnace; at the same time, the flux and gangue of the ore unite to produce a fusible slag, and a diminished supply of gas is again required from the producers. The slow motion of rotation is now again resumed, and as the rotator revolves, the metallic sponge precipitated during the reducing stage is turned over and over by the elbows or prominences already mentioned in the lining of the furnace, and so collects the charge into five or six balls. The slag, which, from its highly basic character, is exceedingly favourable to the taking up of any sulphur and phosphorus that might be present in the charge, is now tapped out into suitable small slag-moulds fitted with wheels, and standing for its reception beneath the slag-hole. After this the balls of spongy, malleable, or steely iron within the rotator are withdrawn one by one, and

may be shingled under the hammer, in the squeezers or other apparatus, exactly after the manner to be described when speaking of the production of bars from the balls of the puddling furnace; or, instead of subjecting the balls to any mechanical manipulation, they may be conveyed direct whilst still heated, and introduced into the open-hearth furnace for conversion into steel.

391. The rotator works off its charge in from three to three and a half hours, and yields, after shingling, about 9 cwt. of metal, leaving the rotator at a red heat, and at once ready, without further preparation, for the introduction of a fresh charge. It is thus noticeable that the process involves for its manipulation but a very small amount of manual labour, either skilled or otherwise, whilst the consumption of coal in the gas-producers is only about 1 ton per ton of balls produced. Malleable iron obtained from the rotator affords upon analysis*—carbon, 0·150 per cent.; sulphur, a trace; silicon, 0·400 per cent.; phosphorus, 0·05 per cent.; manganese, 0·201 per cent.; and iron, 99·198 per cent.

392. The Catalan process, still in use, although not very extensively, in the French Pyrenees and in Spain, requires for its successful working that the ores be rich and readily fusible, and that charcoal should be cheap and abundant; but even under these conditions the product is expensive, owing to the large consumption of fuel (amounting to from three to four tons of charcoal per ton of hammered blooms produced); to the very considerable expenditure of manual labour required for the conduct of the process; and to the heavy loss of iron in the slags, which are essentially rich ferrous silicates ($2\text{FeO}, \text{SiO}_2$). In the Catalan furnace the temperature is not nearly so high as that attained in the blast furnace; so that instead of yielding a slag of calcic silicate, as would occur if a high temperature prevailed, the

* *Iron*, December, 1882.

slag produced is the much more fusible ferrous silicate, which, not being reducible by carbonic oxide, thus entails a considerable loss of iron, and hence only such rich ores as allow of such a loss are available for the process. Further, owing to the fluidity and low temperature at which slags of ferrous silicate are melted, the temperature attained in the furnace is always below that at which carbon combines with iron, and this, together with the decarburising influence of the slags, prevents the formation of cast-iron in the furnace. The product is therefore only an agglomerated mass of wrought-iron or steel, or, more correctly speaking, is always a mixture of soft with steely iron in variable proportions, the preponderance of the one or the other quality depending largely upon the angle of inclination given to the twyer during the smelting process; for if the twyer has a considerable inclination, say 40° with the hearth of the furnace, it affords a quick reduction of the ore, and only a short exposure of the reduced metal to the recarburising influence of the fuel, and soft iron will accordingly predominate in the yield; but if a nearly horizontal position be given to the twyer, then the reduction will proceed more slowly, and the steely quality of the product will be more marked.

393. The Catalan furnace consists of a quadrangular hearth, usually measuring about 3 feet by 2 feet 6 inches, tapering to 2 feet 2 inches at the bottom, the back of the hearth, through which the twyer enters, being formed by the side of the building in which the furnaces stand. The furnace hearth is wider at the top than at the bottom, as shown in Fig. 38, and is built of refractory masonry set in fire-clay. The bottom is supported upon one or more arches which are left in the masonry for the escape of moisture, whilst upon the top of the arches is placed a layer of fire-clay and slag well beaten down, above which, again, is the hearth-bottom of sandstone, granite, or porphyry rock, and from this rise the four

sides of the hearth, of which the side *k* is formed of heavy rectangular bars of iron laid one upon the other as shown; the opposite side, *l*, is likewise built up of iron blocks, but each is of a wedge-shaped section so as to form a convex surface towards the twyer; while the third side is of rough masonry; and the fourth, known as the face or front of the furnace, is formed of two iron plates, in the lower of which is made an aperture for tapping out the slags as required. The conical twyer is of sheet copper simply bent round without any soldering or riveting, and into this the blast-nozzle is inserted at an inclination usually varying from 30° to 40° with the bottom of the hearth, but which angle varies much with the character of the iron which it is desired to produce.

394. The blast for the Catalan furnace is supplied by a *trompe* or water-blowing machine, which consists of a cistern, *a*, into which a constant supply of water is maintained, and this cistern is connected

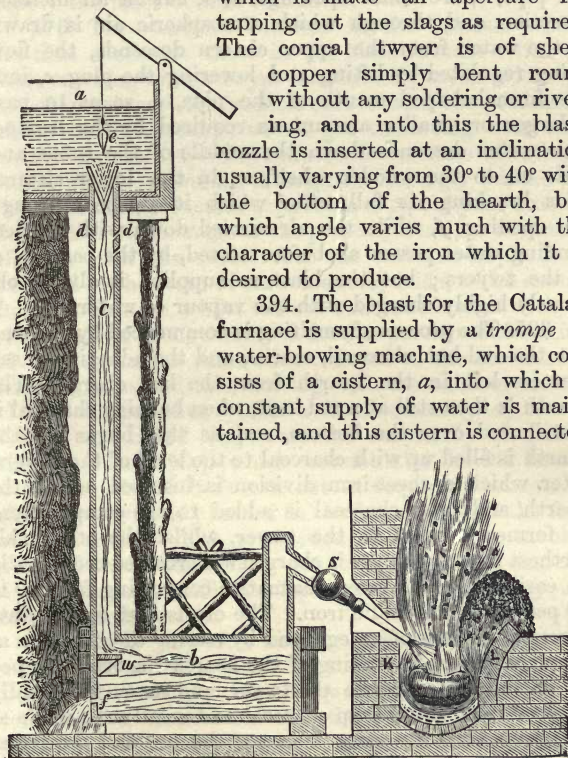

Fig. 38.—Vertical Section of Catalan Furnace and Blowing Apparatus.

with another box or air chamber, *b*, standing below it, by two wooden pipes, *c*, or *trees*, as they are called, each about 20 feet in length, and through which height the water falls into the lower receiver or reservoir, *b*, in which is an opening, *f*, for the escape of the water, and another, *s*, through which the air forming the blast for the furnace is conducted. Towards the top of the pipe, *c*, are small openings, *d*, *d*, cut in an inclined direction, and through which atmospheric air is drawn as the water from the upper cistern descends, the flow being regulated by lifting and lowering the plug, *e*, into the funnel-shaped mouth of the pipe, *c*, so as to pass a larger or smaller amount as required by the *trompe*. The water descends down the middle of the tubes and falls on to the wooden shelf, *w*, in the lower cistern, thus breaking its fall, after which it escapes through the opening, *f*, while the air carried down with the descending water passes as before stated, by the passage, *s*, to the twyers; but the blast so supplied is always obviously highly charged with the vapour of water.

395. The process of smelting is commenced by clearing out the red-hot charcoal, scoriæ, and the adhering fused matters left in the hearth from the last charge. The hearth is thus still at a red heat, when burning charcoal is distributed over the bottom, and as this burns up the hearth is filled up with charcoal to the level of the twyers, after which a sheet-iron division is inserted across the hearth, and more charcoal is added to the compartment so formed nearest to the twyer, whilst the other side farthest from the twyer is charged with roasted ore, usually an easily reducible brown hæmatite containing from 40 to 45 per cent. of metallic iron. The ore is first broken into pieces of the size of an egg, and by raising the partition as required during the filling of the hearth the ore is heaped up on the side opposite the twyer, and its surface finally covered over with damp charcoal and small ore; while at the same time the space between the ore and the twyer side of the furnace is filled up with the larger pieces of

charcoal. The *trompe* or blast is now put slowly into action, when the temperature gradually increases, and any moisture or volatile matters not completely expelled from the ore during the preliminary calcination are driven off; and as the temperature further increases the reduction of the metal is effected, the charge at the same time sinking down, and fresh charcoal being added to supply the place of that consumed.

396. The *reactions involved* in the Catalan process are thus similar to those in the blast furnace—viz., the blast entering by the twyer immediately meets with red-hot charcoal, and combustion ensues with the production of carbonic anhydride, which gas traversing over more heated charcoal is quickly reduced to the state of carbonic oxide, which, ascending through the strongly heated ore, rendered also porous and permeable to gases by the roasting during the earlier stage of the process, acts upon the oxides of iron, with the result that the carbonic oxide is re-oxidised to the state of carbonic anhydride, which escapes from the furnace, whilst the ore suffers reduction with the separation of spongy iron. A further portion of the oxides of iron are at the same time reduced to the condition of ferrous oxide, and this, uniting with the silicious matters of the charge, thus yields a large quantity of a very fusible and liquid slag composed essentially of ferrous silicate ($2\text{FeO}, \text{SiO}_2$), which accumulates in the hearth, and from whence it is run out as required through the slag-hole previously named in the lower plate of the front of the furnace. The production of such a slag involves a considerable loss of iron, but its presence also exercises a decarburising influence upon the plastic spongy iron in the hearth-bottom.

397. It is only after about two hours from the commencement of the process that the full power of the blast is put on, whereupon the charge begins to descend as the consumption of charcoal and the reduction of the ore proceed; whilst the slag and spongy iron produced as above collect in the hearth-bottom, the workmen all the

time moving the descending pasty materials towards the blast-nozzle, whereby they are more strongly heated, and the slag better separated from the reduced metal. Further, to supply the place of the charcoal and ore thus removed, additions of ore and fuel are continually made as the charge descends, until the whole charge has thus been introduced into the furnace. After about five hours' working sufficient metal will have collected in the bottom of the hearth to form a bloom, when the slag, which has throughout been tapped out at intervals, is again run out, and the spongy mass of metal is withdrawn to be shingled under the steam-hammer for the expulsion of the slag and extraneous matters, together with the consolidation of the mass by welding together the spongy granular mass into a more solid bloom. Each charge of some $9\frac{1}{2}$ cwts. of ore, containing from 45 to 48 per cent. of iron, occupies altogether about six hours to work off, and consumes in its reduction about $10\frac{3}{4}$ cwts. of charcoal, yielding, after shingling, cutting up, re-heating, and again hammering, about 3 cwts. of iron bars.

398. The **Bloomery furnaces** are still in use in the United States and Canada, for the smelting of the rich and pure magnetic iron ores and titaniferous iron sands; but the purer and more easily reducible magnetic iron ore is preferable, since the titaniferous sands are more refractory, and therefore do not yield such favourable results; whilst also such ores as contain less than 50 per cent. of metallic iron are not applicable for treatment in this furnace. The Bloomery furnace was formerly much employed in England, but is now quite obsolete in English practice.

399. The furnaces are built in ranges on either side of a quadrangular mass of brickwork, and each measures about 27 or 28 inches along each of its two sides, by 30 to 32 inches along the other sides, and is only from 20 to 25 inches in height above the twyer, and from 8 to 14 inches in depth below the twyer. The sides are formed of cast-iron plates, $1\frac{1}{2}$ inch in thickness,

resting in the hollow cast-iron bottom of the furnace, and placed so as to slope both inwards and downwards. The hollow bottom is cooled by the circulation of a current of water through the castings, by conducting thereto the water which has already circulated for a like purpose through the box in the twyer plate of the furnace, for in these furnaces a blast heated to a temperature of from 280° C. to 320° C. (500° Fahr. to 600° Fahr.) is employed. The twyer, the furnace end of which is of a segmental form measuring $1\frac{1}{2}$ inch in height and $\frac{3}{4}$ inch in width, is laid at an angle so as to direct the blast to the middle of the hearth, and the working pressure of the blast when smelting the finer magnetic iron sands is from $\frac{7}{8}$ of a pound to $1\frac{1}{4}$ pound. In front of the furnace and about 16 inches above the bottom, is an iron hearth measuring about 18 inches in width, whilst in the side of the iron plate beneath it, is the tap-hole for running out the slag from time to time. The blast is heated by passing the air through pipes placed in chambers above the furnace, and which are heated by the waste gases therefrom. The waste gases are conveyed from each pair of furnaces first into a chamber for re-heating the blooms, in which chamber the combustion of any carbonic oxide produced and escaping from the furnace is effected by admitting atmospheric air, which has been heated by passing it through pipes placed over the hearth; and after passing through this re-heating chamber the gases are then used for heating the blast as above.

400. The process of smelting is conducted much in the same manner as in the Catalan furnace, except that in the Bloomery furnace the ore is employed in a finer state of division, and the furnace is worked continually. In the Bloomery furnace the hearth does not require to be cleaned out after the withdrawal of each bloom, in the manner necessary with the Catalan process, owing to the manner of charging the latter, which, as just described, is to place the larger ore against the sloping side

of the furnace farthest from the twyer, and to continue the process by the addition of small ore only, until the whole charge is added. But in the Bloomery furnace, after the fire has been lighted, the hearth is filled with charcoal and powdered ore is scattered over it at intervals, the charge in the meantime descending regularly towards the twyers, its place being supplied by fresh additions of ore and charcoal as required. The smelting is thus effected during the descent of the charge, and without the complete fusion of the reduced metal, which collects in the hearth-bottom as an irregular agglomeration or lump of granular malleable metal, whilst the earthy matters are largely separated as a slag, which is tapped out at the necessary intervals; so that in about three hours from the commencement, additions of ore and fuel having in the meantime been continually made to the furnace, the lump or mass of metal in the hearth weighs about 300 pounds, and it is then lifted by means of a bar, and so held for a few minutes in the zone of higher temperature existing before the twyer, whereby a better welding heat is imparted to it. The lump is then withdrawn and shingled into a bloom, which is afterwards cut up, re-heated in a Bloomery furnace, and drawn out into bars. Each hearth thus yields about 300 pounds of metal in three hours, or 2,400 pounds per day of twenty-four hours, with a consumption of about $62\frac{1}{2}$ cwts. of charcoal to the ton of metal obtained; but the malleable iron so produced is very free from sulphur and phosphorus, although of very unequal and variable temper or hardness, the same bloom presenting at one point the fracture of a very soft metal, and at another that of a hard steely product, thus rendering it best adapted for fusion in the open hearth, or in crucibles, for the production of a steel of uniform temper.

401. In smelting the titaniferous sands of Canada in this furnace, the twyer, instead of having the considerable inclination necessary when treating the magnetic iron ores as above described, is laid nearly horizontal, whilst the

pressure of blast is also lower than when magnetic ores are under treatment.

402. The **High Bloomery** or **Stückofen furnace**, formerly employed on the Continent, but, on account of its large consumption of charcoal, is now generally abandoned in favour of the more economical, indirect method of producing malleable iron by first making pig-iron, and subsequently decarburising and purifying it for the production of malleable iron. This furnace is interesting, however, as occupying a position between the Catalan and Bloomery hearths just described, and the modern blast furnace; since the Stückofen was a small furnace of about 15 feet in height, and 3 feet in diameter at the hearth, with only a single arch at the hearth, which was used alike for the insertion of the twyer and for the withdrawal of the bloom. The blast was supplied by bellows driven by a water-wheel, and the slag was tapped out from a separate slag-hole at the proper intervals.

403. In working this furnace the practice was first to fill it with charcoal, which was ignited at the twyer hole, after which the twyer was inserted and the blast turned on as soon as combustion was thoroughly active; whereupon roasted ores and charcoal were alternately added as required for the conduct of the process, so that in about twenty-four hours sufficient metal had collected in the form of a bloom on the hearth to require removal, an operation effected by first removing the bellows and the twyer, and then making a hole in the masonry (which would be afterwards loosely bricked up) through which the bloom of spongy metal was withdrawn for consolidation by shingling under the hammer. The bloom so obtained was cut up, refined in small hearths or bloomeries with bottoms coated with a brasque of fine charcoal, and the refined bloom was again hammered out for the production of bars.

404. The **Chenot process** for the production of a sponge of malleable iron, to be subsequently hammered and rolled into merchant bars, or to be re-melted along

with solid or liquid carbonaceous matters for the production of steel, although tried somewhat extensively in this country, and much approved of on the Continent some years ago, is not, so far as the author is aware, any longer pursued, except in Spain, where also the process appears likely to be abandoned, since, besides requiring for its employment a supply of very pure and rich ores, its management is one of considerable difficulty, while the consumption of the sponge during its working into balls is very great.

405. At El Desierto Works, near Barracaldo, Spain,* the reducing furnaces consist of a pair of vertical, rectangular brick retorts each 4 feet, 7 inches long, 1 foot wide, and 28 feet high, which are heated externally by coal fires, and charged with ore and charcoal in alternate layers. A portion of the reduced sponge is withdrawn from the bottom of the retorts twice daily, fresh ore and charcoal being filled in at the top to supply its place. The reduction of the ore and cooling of the sponge in the Spanish works occupies three days for its completion, and each retort yields in this manner about 14·5 cwts. of sponge every twenty-four hours, requiring for its production about 25 cwts. of ore, 5 cwts. of charcoal, and over 9 cwts. of coal. The metallic sponge obtained by the reduction of the ore in the retorts is made into balls of malleable or forgeable metal in charcoal hearths, worked with a blast at a pressure of 1·18 inch of mercury, each charge of about 202 lbs. weight requiring for its balling about 55 lbs. of charcoal; and of such charges each hearth works off from 15 to 20 in the day of twelve hours. For every ton of merchant bars produced from the sponge, there are consumed about 37 cwts. of the latter, and 10 cwts. of charcoal. The slag or cinder produced in the process is very rich in iron, and the metal yielded in Spain is said to be soft and malleable, and to be especially in request for the production of the nails used in the shoeing of oxen.

406. The retorts employed in France during the

* "Annales des Mines," 1879.

working of the Chenot process were larger than the above, measuring about 6 feet, 6 inches in length, 3 feet in width, and 27 feet, 6 inches in height, and were built in pairs within a cubical mass of masonry surmounted by a cone of elliptical section, the retorts being heated externally by a series of vertical flues passing around them from the fire-places at the bottom, and leading to a flue at the top, communicating with the atmosphere. Each of these retorts was charged with about 30 cwts. of calcined ore, previously broken into fragments of about $1\frac{1}{2}$ cubic inch and mixed with some 10 cwts. of wood charcoal, or if the ore were of a pulverulent nature it was mixed with such reducing matters as resin, of which about 3 per cent. was added for the agglomeration of the ore. The reduction of this charge extended over three days, whilst other three days were necessary to cool down the metallic sponge out of contact with the air; for the metallic sponge when first reduced, if directly exposed to the atmosphere, takes fire and burns with the production of oxide of iron; hence, for the purpose of cooling the reduced metal, the retorts were made slightly larger at the lower than at the upper end, and the charge was allowed to fall (by withdrawing the bottom bars of the retorts) into a sheet-iron cooler placed beneath them, and from whence, when sufficiently cold, it was removed to another iron case below which was a waggon running on rails, and placed level with the ground. The sponge thus obtained was either introduced into crucibles along with charcoal or other solid matters rich in carbon, and then melted for the production of steel, or it was balled in a charcoal hearth, and then, after hammering, cutting up, piling, and reheating, was rolled into bars in the usual manner.

407. The spongy, pulverulent material obtained from the Chenot retorts has a light-grey colour, is very soft and malleable, and can be cut with a knife; under a pressure of about 2 tons to the square inch it can be compressed to about one-fifth of its original volume, evolving great heat during the compression and solidification.

CHAPTER XII.

INDIRECT METHODS FOR THE PRODUCTION OF
MALLEABLE IRON.

408. By the older or *direct processes* the production of malleable iron was the direct product of the reduction of iron ores; while by the more modern or *indirect processes*, cast-iron is first produced by the smelting of iron ores, and the cast-iron so obtained is subsequently subjected to a series of operations by which its conversion into wrought iron is effected.

409. By far the largest proportion of the malleable iron now manufactured is produced by the indirect methods—that is to say, by subjecting pig-iron to decarburisation in the puddling or reverberatory furnace—either with or without the preliminary operation of *refining* for the production of a white iron better adapted to the requirements of the puddling furnace. The *process of refining* effects the partial decarburisation and purification of grey pig-iron with its conversion into white iron; but, besides the puddling, or combined refining and puddling processes, the indirect methods also include the operations for the conversion of pig-iron into malleable iron in *open-hearths* with coke or charcoal as the fuel, in the manner still pursued in South Wales, Sweden, &c., but more particularly in South Wales, as used for the production of the so-called coke and charcoal plates respectively required in the manufacture of tin-plates; but the production of coke and charcoal plates is being much curtailed by the extensive use of steel sheets in their stead.

PRODUCTION OF MALLEABLE OR WROUGHT IRON FROM
PIG-IRON IN OPEN HEARTH FURNACES.

410. Although of considerable antiquity and great simplicity, the method of producing malleable iron by the

treatment of pig-iron in open-hearth fineries is still diminishing in use and importance. The course usually pursued in these methods is simply to melt pig-iron in shallow hearths, and to expose the melted metal to the decarburising influence of a blast or current of atmospheric air directed upon its surface from an inclined twyer, to the exclusion of all other agencies; or the decarburisation may be effected if white iron approaching in composition to refined metal be under treatment, by the introduction into the furnace of such decarburising agents as hæmatite, hammer-scale, and the like, without any material assistance from the decarburising influence of the blast.

411. The essential difference between the open hearth and the puddling process is, that in the last-named the fuel employed is raw coal, and the metal is melted and converted into wrought iron without coming into contact with the fuel; while in the open-hearth fineries the conversion is effected with the metal and the fuel (coke or charcoal) in contact upon one and the same hearth.

412. The operations for the conversion of cast into malleable iron upon the open hearth embrace three stages, if grey pig-iron be under treatment. In the *first stage* the grey iron is converted into white iron in a *coke refinery*; the *second stage* is that of lifting and breaking up the metal in the furnace, while the *third or final stage* is that of balling the product; and according as these three operations are conducted in one or more furnaces arise the principal modifications of the procedure observed in different localities; thus the whole operation may be conducted in two separate furnaces consisting of one *refinery*, or *running-out fire*, working in conjunction with two charcoal *fineries*, or it may be completed in one hearth or fire. The former method represents the mode of procedure in South Wales, whilst the latter constitutes the *German or Walloon process* of Sweden, &c.

413. The South Wales process is employed for the manufacture of the metal used in the production of what

are known commercially as coke plates, and, briefly stated, consists in the fusion of pig-iron of good quality in a *coke refinery* or running-out fire, followed by a further fining and working of the refined metal so produced in a *charcoal finery*, after which the product is worked under the steam hammer or helve into large cakes or *stamps* of from $1\frac{1}{2}$ inch to 2 inches in thickness, and which are then re-heated in the *hollow-fire*, forged under helves, and rolled into bars; these latter are then cut up into proper lengths for rolling out in the manner to be subsequently described, into sheets or plates of the required thickness.

414. The *refinery* or *running-out fire* just mentioned is a small square hearth, measuring about 18 inches along the side, and to this hearth a blast of atmospheric air is supplied through a pair of inclined twyers, the furnace being similar except as to size, to the refinery described and illustrated in Fig. 40 (p. 239), which is employed for the conversion of grey into white iron preliminary to dry puddling in the reverberatory furnace. Worked in conjunction with the refinery of South Wales are two charcoal *fineries* placed immediately in front of it but at a lower level, so that the charge of imperfectly refined metal can be tapped from the bottom of the refinery hearth, and run direct along inclined grooves or channels into the two fineries between which the charge of one refinery is divided.

415. The *charcoal fineries* are also small rectangular hearths surmounted by a chimney or stack (Fig. 39), and supplied with cold blast through one water twyer. The hearth is formed of cast-iron plates, and the bottom is made hollow in order that it may be kept cool by the circulation of air beneath it; the side plates along three sides of the hearth are placed vertically, whilst the fourth or working side is made to slope outwards.

416. The refinery or running-out fire uses coke as its fuel, and upon the hearth, previously charged with coke, there is placed at each charge from 5 to 6 cwts. of

pig-iron, which then slowly melts and collects on the bottom of the furnace, becoming partially decarburised and refined by the oxidising action of the inclined blast.

The metal so collected in the hearth is then tapped out from the bottom and divided between two charcoal fineries, which are still at a red heat from the working off of the last charge. The charcoal fineries, after the withdrawal of a charge, are cleared of residual matter before the introduction of a fresh charge from the refinery, and any residuary metal that remained on the hearth is collected into a ball to be added to the next charge. In tapping the metal from the refinery into the two fineries, care is observed to keep back the slag from the latter as much as possible, but a little always passes into the fineries and quickly solidifies on the

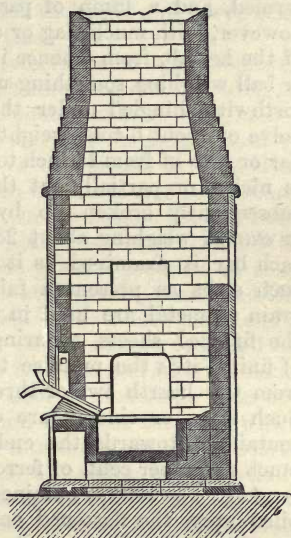

Fig. 39.—Elevation of Charcoal Finery.

surface of the metal, from whence it is removed and a quantity of charcoal then thrown over the metal. At this stage the blast is turned on, and the partially solidified metal is broken up by the workman, who then draws the metal towards the twyer side of the hearth whilst water is lightly thrown over the surface of the charcoal to prevent loss by its burning away, and more fuel is added as required during the progress of the process. The residual ball of metal collected from the hearth after the withdrawal of the previous charge is now added, and in a little over one hour from the commencement, the

workman having in the meantime constantly broken up and raised the metal from the hearth bottom towards the twyers, the metal will have "come to nature," as it is termed, and a lump of pasty, malleable metal, mixed however, with much slag or cinder, collects in the bottom of the hearth, from whence it is withdrawn in one bloom or ball weighing something under 2 cwts. This bloom is forthwith shingled under the steam-hammer or under a helve of about 6 tons weight, for the production of a flat bar or slab of from $1\frac{1}{2}$ inch to 2 inches in thickness, which is nicked or partially cut through so as to yield when subsequently broken up by the sledge hammer, pieces or *stamps* weighing about 28 lbs. each. The fracture of each bar is examined as it is thus broken up, and only such slabs as present a fairly crystalline and uniform grain of metal are used in the formation of the pile for the finished sheets. During the conduct of the process of fining, it is the practice to tap out the slag or cinder from the hearth two or three times, as may be required. Such slags or cinders are of a highly basic character, containing towards the end of the fining operation as much as 75 per cent. of ferrous oxide.

417. The *stamps* obtained as above are subsequently piled upon the flattened end, from 12 to 18 inches in length, of a staff made of a metal similar in quality to that of the stamps themselves. The pile formed by placing about three of the stamps upon the staff is raised to a welding heat in the hollow-fire, and then welded into a solid mass under the hammer, whereupon the slab so formed is nicked on the under side and then doubled upon itself, whereby the top and bottom surfaces of the pile are produced from the same surface of the slab. The pile is again raised to a welding heat in the hollow-fire and again welded under the hammer into a billet, which is taken whilst still hot, sheared from the handle of the staff, and at once rolled into a bar.

418. The particular method of procedure just described for the production of the hammered bloom is known as

the method of "tops and bottoms," from their upper and lower surfaces being produced from the same face of the slab, and these blooms are afterwards sent to the rolls for rolling out into sheets, of which the upper and lower sides present the same kind of surface.

419. The *hollow-fire* just referred to as being employed for reheating the stamps for rehammering and rewelding, is a deep rectangular hearth or chamber of brickwork, arched over at the top, whilst in the sides are openings closed by sliding doors. The bottom of the hearth is formed of cast-iron plates, beneath which the air is free to circulate for keeping the plates cool. On the bottom plate is built a layer of fire-brick, and the hearth is not provided with any chimney or stack, but the gaseous products of combustion before escaping to the atmosphere, pass from the hollow-fire through a partition or wall between it and a second chamber in which the pile of stamps is placed for a preliminary heating, before it is inserted into the flame of the hollow-fire. The firing door or stoke-hole is on one side of the chamber, and through this door the coke, which is the fuel here employed, is introduced on to the hearth bottom. The chamber is at all times only partially filled with fuel, and the combustion of the same is maintained by a blast of atmospheric air introduced from an inclined twyer near to the surface of the fuel. In this manner the chamber or furnace above the fuel is filled with flame, which plays around the stamps placed within it for reheating; the pile does not rest upon the bottom, but is supported in the midst of the flame, in which manner it is raised to a welding heat without coming into contact with the fuel, the handle of the staff all the time projecting beyond the furnace door.

420. The **Lancashire Hearth** or Swedish Finery is also a rectangular closed chamber or hearth, the sides and bottom of which are of cast-iron plates. The hearth communicates by horizontal flues with the stack, and the pig-iron is first placed in them for heating before it is drawn forward into the hearth itself. Charcoal

is the fuel employed in this hearth, and a blast heated to a temperature of 100° C. (212° Fahr.) is introduced through one twyer, this temperature being given to it by passing it on its way to the twyer through a series of iron tubes heated by the waste gases of the finery; the blast is delivered at a pressure of from 1 lb. to $1\frac{1}{4}$ lb. to the square inch. The method of procedure with the Lancashire hearth is first to charge upon the heated hearth a quantity of charcoal, upon which is then drawn from the flues or heating chambers already mentioned a charge of about 2 cwts. of the pig-iron previously placed there for heating by exposure to the gases in the flues; the blast is then turned on and more charcoal is added, in which manner the metal is slowly melted and trickles down before the blast, by which it is partially decarburised and fined before it reaches the hearth bottom, where it partially solidifies or hardens, and the workman is constantly engaged breaking it up with his bars and raising it before the blast for further fining and decarburisation. As the decarburisation thus proceeds, the metal becomes less fusible, and the workman is able to raise the whole charge to the top of the fuel in the hearth, and this being accomplished, it is immediately followed by the addition of fresh charcoal and an increase in the temperature by the turning on of more blast, whereby the partially fused metal is again perfectly melted, and thus better separated from the slag with which it is mixed; and, this being effected, the fined metal is collected into a ball upon the hearth bottom, which ball is then withdrawn from the furnace, shingled as usual, and cut up into suitable lengths for piling and reheating, either in a separate fire or in a gas-furnace. The pile is then rewelded and further treated under the hammer, or rolls for the production of malleable bars.

421. The fuel consumed in this hearth amounts to about 150 lbs. of charcoal per 100 lbs. of bars produced, whilst the process is attended with a loss of about 15 per

cent. of the weight of the pig-iron introduced into the furnace or finery.

422. The Walloon process, like the Swedish-Lancashire hearth last described, is an example of the three operations of melting down, breaking up, and balling of the product in one and the same furnace, as a continuous operation, and is principally interesting as being the method according to which, in Sweden, the famed Dannemora malleable iron is produced.

423. The furnace employed in the Walloon process is a simple quadrangular hearth measuring from 2 feet to 2 feet, 6 inches in width, and about 10 inches in depth; it is formed of thick cast-iron plates, and is fitted with an inclined twyer through which the blast is introduced from two pairs of primitive bellows, worked by cams upon a revolving shaft driven usually by water power. The hearth is surmounted by a hood and chimney of brickwork, for taking away the gases, &c., from it. In one side of the hearth, and opening near the bottom of it, is an aperture through which the liquid slags produced by the process are tapped out.

424. The hearth, having worked off its last charge, is partially cleaned by tapping out most of the remaining slag, but it is still necessary to leave in the hearth sufficient of the highly basic slag to assist in the decarburisation of the succeeding charge; for *the fining in this process is always conducted in a bath of slag*. Besides the slag, there will also remain a residue of incandescent charcoal, and upon this the succeeding charge of from 2 to 3 cwts. of metal, previously cast into small pigs suitable for manipulation in this hearth, is placed. The hearth is then filled up with fresh charcoal, whereupon the blast is turned on, at first more slowly, but more freely as the process goes on. The metal for refining soon begins to melt, and falls down in front of the blast in its descent towards the hearth bottom; it thus becomes partially decarburised and purified under the oxidising influence of the blast, the decarburising action being also assisted

by the highly basic slags of ferrous silicate, which collect upon the surface of the metal in the hearth. The slags, as before mentioned, are tapped out through the slag-hole as their quantity becomes excessive, only sufficient being retained in the hearth to cover the fluid metal, and promote by its basic character the desired decarburisation of the pig-iron; but the richer portions of the slags tapped out are collected, and, along with the hammer-scale obtained in the hammering of the bars, are added to a subsequent charge during the first or melting-down stage of the process. A pasty mass of partially-refined iron thus collects in the bottom of the hearth, and the workman, with the assistance of a strong iron bar, then collects the metal into one mass or bloom, and raises it on to the top of the fuel, more fuel being at the same time added and the pressure of blast further increased. In this manner the metal again melts and passes down as before into the hearth, having undergone a further degree of fining or decarburisation, by exposure to the oxidising influence of the blast, so that the metal has by this time assumed a spongy condition, when it is again collected into one bloom or ball, and withdrawn from the furnace to be shingled for the expulsion of mechanically-mixed slag and the consolidation and welding together of the particles of the spongy mass. The blooms thus obtained weigh from 1 to 2 cwts. each, and are cut up at the same heat under the hammer into three or four pieces of suitable lengths, which are then reheated, and again hammered for drawing out into bars.

425. The melting-down stage of this process occupies from three to three and a-half hours, and the whole operation, including balling and shingling of the blooms, requires about five hours for its completion. The hearth is worked much hotter than the ordinary charcoal finery, and the loss of metal is from 15 to 20 per cent. of the charge of pig-iron introduced, while the consumption of charcoal amounts to about 150 lbs. for every 100 lbs. of pig-iron treated.

426. During the drawing down of the shingled bloom into bars some five or six reheatings of the metal are necessary, of which the first is effected in the finery hearth itself, during the first or melting-down stage of the process, the shingled bloom being held for this purpose by a pair of suitable tongs in the fore part of the hearth, where the temperature is sufficient to heat the bloom almost to a welding heat; but the later reheatings are effected in a separate fire.

427. The exact method of procedure observed in the working of the Walloon process varies somewhat from that described above in different works and localities. Thus, instead of introducing the charge on to the hearth in the form of small pigs or slabs, as previously described, it is not unusual to prepare the pig-iron, which is generally of a white or mottled quality, in slabs of 15 or 16 feet in length and 3 inches in thickness, and when the hearth is filled up with charcoal and the blast turned on, a slab is introduced by resting it on a roller in front of the hearth, whilst its extremity is pushed over the plate in front of the twyer, and so held in the middle of the hearth at a distance of 9 or 10 inches above the bottom. The end of the slab is thus presented to the high temperature of the hearth near the twyer, and as it melts down it is gradually pushed farther into the hearth until in this manner the amount of metal required to produce a bloom of about 100 lbs. in weight has been introduced. By this method the fining or *coming to nature*, is very rapid; and the workman during the melting down also constantly rabbles the metal with iron bars as it collects on the hearth.

428. The metal produced in these charcoal or Walloon fineries is of a superior quality; but attempts to use hot-blast and coke instead of cold-blast and charcoal are attended with a deterioration in the quality of the product.

CHAPTER XIII.

REFINING OF PIG IRON, OR THE CONVERSION OF GREY
INTO WHITE IRON IN THE COKE REFINERY.

429. WHEREVER the process of *dry puddling* (p. 248) is pursued for the production of the better qualities of malleable iron such as those yielded by the Yorkshire furnaces, this preliminary treatment of pig-iron for the production of a partially decarburised and desilicised white or refined iron is still pursued. Now, in *dry* puddling the oxidation necessary for the conversion of pig-iron into malleable iron is more dependent upon the action of the atmospheric oxygen than it is in pig-boiling or wet-puddling, for in the latter slags rich in oxides of iron are present in larger quantity, and the oxidation of the impurities in the pig-iron is more largely affected by these rich slags than by atmospheric oxygen. Hence dry-puddling is only applicable to the working of white or refined iron, since such metal in passing from the solid to the molten state, passes through a soft pasty condition not afforded by grey iron under like conditions, and this state of the pig-iron is highly favourable to oxidation by the oxygen of the air.

430. The refining of pig-iron now under consideration is, therefore, only preliminary to the puddling of the metal in the reverberatory furnace; and it consists in melting pig-iron in a rectangular hearth with coke or charcoal; and at the same time directing upon the surface of the melted metal a blast of atmospheric air from several inclined twyers, whereupon under such strongly oxidising conditions, the pig-iron under treatment (usually grey), besides undergoing a partial decarburisation, has its silicon also largely oxidised with the formation of silica, and this,

uniting with ferrous oxide yields a highly basic slag of ferrous silicate, in which slag also occurs a proportion of the phosphorus and sulphur present in the original pig-iron. The result is the production of a white or partially purified *refined metal*, which is subsequently more readily and quickly converted into malleable iron in the puddling furnace, owing to the decreased fluidity of the

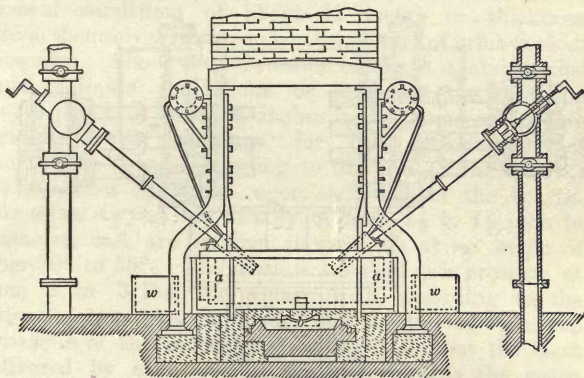

Fig. 40.—Elevation of the Refinery for converting Grey into White Iron.

molten refined metal, and its greater freedom from impurities. The refined metal may be either run directly from the refinery to the puddling furnace, or, as is more usual, it may be cast into forms easily broken up into pieces suitable for introduction into the furnace. It is thus noticeable that whilst the object of the Swedish and German *fineries* already described was the production of malleable iron direct, the product of the English refinery now being considered, is only a partially purified or refined metal requiring further treatment in the puddling furnace for its conversion into malleable or wrought iron.

431. The refinery or running-out fire, in which the refining operation is conducted, consists of a strong

cast-iron framework, surmounted by a low brick chimney or stack of from 16 to 18 feet in height (Figs. 40, 41). The hearth is a quadrangular cavity about 4 feet square and from 15 to 18 inches in depth, and which is bounded on two of its sides and at its back by cast-iron water blocks, *a a*, fitted within the vertical iron framework of the furnace, and through these blocks a current of water

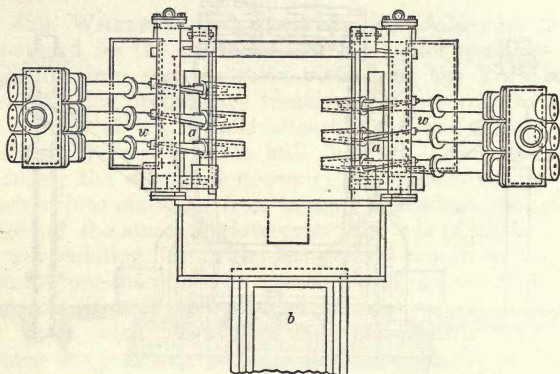

Fig. 41.—Plan of the Refinery and of the Mould for the Refined Metal.

constantly circulates. The front side of the hearth is closed by a cast-iron dam-plate, in which the tap-hole is placed, and by which both metal and slag are tapped out into the casting-pit or pig-mould, *b*, made of thick cast-iron plates or blocks, with rebated joints luted with fire-clay and held together by suitable clamps. The pig-mould is about 12 inches in width by from 14 to 16 feet in length; it is placed in front of the refinery, and rests longitudinally upon the edges of two long cast-iron or brickwork cisterns, through which a current of water flows to aid in the quicker cooling of the refined metal, both by cooling the mould and by supplying the water which is thrown over the surface of the heated metal in the mould. The water in these cisterns is

maintained at a level of about 1 inch below the underside of the pig-bed or mould. In order to still further facilitate the breaking-up of the plate of refined metal so obtained, a projecting rib is often left in the bottom of the mould, producing a corresponding groove and line of weakness in the plate of metal cast therein.

432. The bottom of the hearth is formed of blocks of dressed sandstone of about 12 inches in thickness, which themselves rest upon a substructure of brickwork or masonry. Above the side water blocks, *a a*, and carried upon suitable projections or lugs, are the cast-iron twyer plates of some $2\frac{1}{2}$ inches in thickness, which are provided with openings for the introduction of the two or three (according to the size of the hearth) blast nozzles or twyers upon each side of the hearth. The water twyers are usually of from $1\frac{1}{2}$ to $1\frac{3}{4}$ inch in diameter, and are inclined downwards at an angle of from 30° to 35° . The blast is supplied at a pressure of from 2 to 3 lbs. per square inch, according to the nature of the coke employed; and the twyers upon the two sides of the refinery are arranged so that the blast delivered by each one is directed towards the space between the two twyers on the opposite side, thereby distributing the blast more uniformly over the whole surface of the molten metal in the hearth; each nozzle is further provided with a stop or regulating valve for adjusting the supply of blast from each twyer during the working of the charge. *w w* are water troughs or boshes into which the waste water from the twyers is delivered, and in which the workman cools his tools during the working of the charge. The back of the furnace between the base of the stack and the water blocks is closed by wrought or cast-iron doors hung to the side frames, and the front above the dam-plate is also closed by a sliding door, connected with a lever by which it can be readily raised or lowered. A *dust-plate* is also usually fixed on the dam-plate to facilitate the filling and working of the fire.

433. In the *Yorkshire refineries* five twyers only are employed, two being placed in one side and three in the opposite side of the hearth, but arranged as before so as not to oppose each other. In some of the smaller refineries, however, sometimes but one blast nozzle is used, and that is introduced at the back of the furnace, in which case also the several parts, as the water blocks, moulds, and the castings of the framework, are all made proportionately smaller and lighter in section.

434. According as the charge of the refinery is made up of selected pig-iron, old castings, and other scrap, &c., or, as in rarer cases, of the molten pig-iron run direct from the blast furnace into the refinery, so the refineries are distinguished as "melting-down" and "running-in" respectively; and while the melting-down refineries are always built at some distance from the blast furnace, it is usual to build the running-in ones in the immediate vicinity of the blast furnace from which they are to receive their charges of molten metal.

435. The refinery works continuously—that is, as one charge is tapped out, the hearth before it has cooled down is immediately prepared for the reception of the next. But on commencing to work a new furnace, or after a stoppage, a quantity of broken sandstone is first spread over the floor of the hearth and a fire made in the centre, whereupon coke is added through the folding doors ordinarily closing the back of the furnace, and a light blast is at the same time turned on; after this the charge of pig-iron, scrap, and coke is introduced by piling on the materials in alternate layers, until the whole charge, varying with the dimensions of the refinery but averaging about two tons of metal in the larger furnaces, has been made up, when more fuel is added to the top of the pile, and the full power of the blast turned on. Such a charge requires about six cwts. of coke for its refining, and the process occupies from three to four hours for its completion according as white or grey iron is under treatment; the last-mentioned taking a little more time

to arrive at the same stage than is necessary when white iron forms the raw material. The refining is accelerated by the addition to the charge of basic slags, cinders, or scale, such as is obtained from the reheating furnaces, hammer-scale, &c. ; such additions acting as oxidising agents, and so assisting the oxidising action of the blast, whilst also increasing to a small extent the total yield of iron from the refinery, since the carbon of the pig-iron is partially oxidised by the oxygen of the oxides of iron present in the scale or cinder, and an equivalent amount of iron is at the same time reduced and added to the yield.

436. The first effect of the heat in the newly-erected or repaired refinery is to soften the sandstone and glaze the surface of the hearth. The pig-iron, &c., of the charge begins to melt after the lapse of about one hour from the commencement, and it trickles down during its fusion through the mass of coke on to the bottom of the furnace, where, in from one and a-half to two hours the whole of the charge is collected, and so lies in a fused condition beneath the superincumbent coke, of which latter more is now added. The blast is continued for another half-hour or a little more, during which time a further proportion of silicon from the pig-iron is oxidised, producing silica, which, together with an additional amount of silica derived from the ash, &c., of the fuel, combines with ferrous oxide resulting from the oxidation by the blast of a portion of the iron, thereby producing a highly basic and readily fusible slag or cinder of an orthosilicate or ferrous silicate of the formula $2\text{FeO SiO}_2 = \text{Fe}_2\text{SiO}_4$, containing from 40 to 60 per-cent. of iron, and presenting when cold the usual very dark-blue or black colour, with the vitreous, lustrous fracture characteristic of cinders rich in iron. Such a slag exercises, as previously shown, a powerfully decarburising influence upon the molten metal beneath it, and thus under the joint influence of this slag and the oxygen of the blast, the carbon and silicon with smaller quantities of sulphur and phosphorus and the greater

portion of the manganese present in the original pig-iron are oxidised, as indicated by the accompanying analyses of the original pig-iron, and of the refined metal obtained

ANALYSES OF REFINERY CINDER OR SLAG.*

	Dowlais (Riley).		Bromford Crystallised cinder. (Forbes).
	Ordinary cinder.	Crystallised cinder.	
Ferrous oxide . . .	65.52	54.94	61.28
Silica	25.77	33.33	22.76
Manganous oxide . .	1.57	2.71	3.58
Alumina	3.60	5.75	7.30
Lime	0.45	1.19	3.41
Magnesia	1.28	0.50	0.76
Sulphur	0.23	—	0.46
Ferrous sulphide . .	—	0.27	—
Phosphorus	1.37	0.99	—
Copper	—	traces	—
Per-centage of iron	50.96	42.84	47.66

ANALYSES OF REFINED IRON.

	Ebbw Vale (Noad).		Bromford (Dick).	France (Regnault).	
	Pig iron.	Refined iron.	Refined iron.	Pig iron.	Refined iron.
Carbon . Graphite	2.40	0.30	3.07	3.00	1.7
Silicon	2.54	0.32	0.63	4.50	0.5
Sulphur	0.22	0.18	0.16	—	—
Phosphorus	0.13	0.09	0.73	0.2	—
Manganese	0.86	0.24	trace	—	—
Insoluble matter . .	—	—	0.14	—	—
Iron	—	—	95.14	92.3	97.8

* Percy : "Metallurgy," Vol. II.

therefrom. More fuel is added to the refinery from time to time, that the temperature of the hearth may be maintained by the combustion of the fuel under the action of the blast, until the desired degree of fining has been effected. The whole time occupied in the refining process for an average charge is about three hours, or a little less when white iron predominates in the charge, and somewhat beyond this time if grey iron be under treatment. During the refining the surface of the metal on the hearth is in a continual state of agitation, produced by the escape of carbonic oxide, formed during the decarburisation of the metal by the oxygen of the blast, and by the fluid basic slags upon the surface of the melted metal.

437. When the refining is considered complete or has been carried as far as is required, the contents of the hearth, slag and metal together, are tapped out into the cast-iron mould, *b* (Fig. 41), when the slag or cinder floats upon the surface of the metal, and being the more fusible of the two remains fluid after the surface of the metal in the mould has become partially solidified, and the slag can thus be tapped off from the surface of the refined metal into other moulds placed for its reception at the lower end of the mould, *b*, while the plate of refined metal is the more rapidly cooled, and rendered also more or less hard and brittle by throwing a quantity of water over its surface.

438. The plate of *fine metal, refined iron, plate metal*, or simply metal, as the product of the refinery is variously called, consists of a plate of metal of from 1 to 3 inches in thickness, 12 inches in width, and from 12 to 14 feet in length. It is grooved along its under side, and has been rendered brittle by quick cooling, so that it is easily broken up into pieces suitable for ready transport to the puddling furnace, where its final conversion into malleable or wrought iron is effected. The plate of fine metal presents a bright silvery-white fracture, the lower part of the slab affording a compact radiated or columnar

structure, while the upper portion presents a dull and cellular appearance on fracture.

439. In the melting down and refining of pig-iron, the loss of iron is somewhat greater and the consumption of fuel is about 20 per cent. in excess of what is required when the metal is taken in the fluid state direct from the blast furnace; but the average loss may be taken as equal to 10 or 11 per cent. of the weight of the pig-iron operated upon. The loss is greater in refining hot-blast than it is with cold-blast pig-iron, owing to the larger proportion of silicon, phosphorus, sulphur, manganese, &c., in the former than in the latter; while pig-iron smelted from Blackband ores, owing to its extreme fluidity when melted, is difficult of treatment in the refinery, and occupies accordingly a longer time for refining.

440. In the ordinary melting-down and refinery process about 24 cwts. of good grey iron are required to yield 1 ton of refined metal, with a consumption during the process of about $2\frac{1}{2}$ cwts. of coke; and about 136,000 cubic feet of blast per ton will be required if white iron, or 153,000 cubic feet if grey iron, be the metal to be refined. The weekly produce of a refinery with six twyers working upon grey iron ranges from 80 to 100 tons, while 150 to 160 tons may be refined if white iron be the subject of operation. If the metal be run in its fluid state direct from the blast furnace into the refinery, then about 22.3 cwts. of common forge, or 21.1 cwts. of good grey iron, will suffice to yield one ton of refined metal, the consumption of fuel at the same time being reduced to about 2 cwts. of coke, and requiring only 94,000 cubic feet of blast per ton of metal treated.

441. The washing process of Baron Krupp, as pursued at Essen, Prussia, is a species of refining in which the silicon and phosphorus of the pig-iron are largely oxidised and removed by their reaction at a high temperature upon refractory but rich oxides of iron, such as rich iron-ores or hammer-scale. Mr. I. L. Bell discovered that by thoroughly mixing molten pig-iron and such oxidising

ores upon the bed of a reverberatory furnace, in an oscillating cylinder or in other suitable apparatus, a violent reaction ensued, and that, in ten minutes from its commencement, the silicon and phosphorus of the pig-iron were oxidised, and passed into the slag, the former being reduced from 1·8 to 0·05 per cent., and the latter from 1·4 to 0·10 per cent. ; but the carbon during the same interval was but slightly affected, being reduced only from 3·5 to 3·3 per cent.

442. As now carried on at the Essen Works, the washing process is conducted upon the hearth of a Pernot revolving regenerative gas furnace, such as is described at p. 297, the revolving hearth of which is about 12 feet in external diameter and 3 feet deep, and is lined or fettled to a depth of 9 inches over the bottom and 15 inches on the sides with lumps of a refractory ore containing from 6 to 15 per cent. of silica, or if more than the latter limit be present, then an addition of lime requires to be made to combine with the excess. The charge of pig-iron, weighing from 5 to 7 tons, and containing, if possible, about 1 per cent. of manganese, is melted in a cupola, and run therefrom into the furnace, rotating at the rate of eleven revolutions per minute, where the metal is heated to a temperature in excess of that required for the puddling process, but below that required for the fusion of steel. At this temperature a violent reaction at once ensues, as above, which lasts from five to eight or nine minutes, during which the slag produced during the process enters into a state of violent ebullition, and runs over the sides of the hearth. The termination of the process is marked by the sudden evolution of a considerable volume of *carbonic oxide* which had previously been almost *nil*. The fined metal is freed from much of its silicon and phosphorus, though only very slightly decarburised, and it is then either run into pigs or is at once transferred to the open-hearth steel-melting furnace for the production of steel by the latter process. After each charge the hearth requires to be refettled with small ore.

CHAPTER XIV.

PUDDLING, OR THE PRODUCTION OF MALLEABLE IRON BY THE DECARBURISATION OF PIG-IRON IN THE REVERBERATORY FURNACE.

443. By far the largest proportion of the wrought or malleable iron occurring in commerce is the result of the partial decarburisation and more or less complete removal of silicon, sulphur, phosphorus, manganese, and other foreign elements or impurities from pig-iron, by its treatment in the reverberatory or puddling furnace; under which type of furnace is included, besides the fixed ordinary furnace, also the various revolving furnaces heated either by raw coal or by gaseous fuel.

444. The word *puddling* was originally restricted* to the working of refined iron which never became thoroughly liquid, but was in a puddled or pasty state throughout; and when unrefined iron began to be worked and was found to melt perfectly, and boil up freely, the process was then termed "*pig-boiling*."

445. As previously noted, the great distinction between the puddling process and the treatment of pig-iron in the open hearth is, that in the open-hearth finery the pig is melted in contact with the fuel, and that only the purer materials, therefore, such as charcoal or coke, are available for use in such furnaces; whilst in the reverberatory or puddling furnace the metal is melted on the bed of the furnace without coming into contact with the fuel employed, and hence raw coal, inferior qualities of fuel and other materials, can be used without materially deteriorating the quality of the product. Further, the puddling process admits of a much more extensive use of the various mechanical labour-saving devices which have during late years been applied to these operations.

* Proceedings of Institute of Mechanical Engineers, 1877.

446. The reactions involved and changes effected during the puddling process are similar to those occurring in the open-hearth finery. The first result of the treatment of the pig-iron upon the hearth of the reverberatory furnace is to effect the conversion of any graphitic carbon into combined or dissolved carbon, since it is only upon carbon in the combined state that the subsequent oxidising influence of atmospheric oxygen is appreciably effective. Secondly, the combined carbon is oxidised to the condition of carbonic oxide, either, as in "dry-puddling," by the oxygen of a blast of atmospheric air, or by the current of air which passes on its way from the fireplace to the stack over the exposed surface of the liquid metal; or, as in "pig-boiling" or "wet-puddling," the production of carbonic oxide is the result of the reaction of the combined carbon of the pig-iron upon the oxides of iron introduced into the furnace in the form of forge-scale, finery-cinder, tap-cinder or "bull-dog," the purple ore known as "blue-billy," or the purer ores, such as hæmatite, magnetite, or roasted spathose ore, each or several of which are added to the furnace at different times during the process, and should thus be as free as possible from earthy matters. Thirdly, the silicon, sulphur, and phosphorus of the pig-iron are largely oxidised during the puddling process, and escape in combination with iron into the tap-cinder or slag of the puddling furnace. Lastly, the charge is collected into balls of a size suitable for withdrawal from the furnace and treatment under the hammers or squeezers. It may be noted in passing that the division of the subject into *dry-puddling* and *pig-boiling* respectively, as will be fully noticed hereafter, depends upon whether the decarburisation and oxidation of the impurities of the pig-iron are more largely effected by the oxygen of the atmosphere, and to a minor degree only by the oxidising basic fluxes, as hæmatite, forge-scale, tap-cinder, &c., enumerated above, or *vice versâ*, where the major effect is produced by the reduction of

the oxides of iron in the oxidising materials above mentioned, whilst the oxygen of the air plays only a minor part in the reactions.

447. *White iron is more suitable than grey iron* for conversion into malleable iron by the puddling process, since the former, when raised to near its melting-point, assumes a pasty state highly favourable to the removal of its carbon and silicon under the oxidising influence of atmospheric oxygen, or of the other oxidising agents employed for the decarburisation and purification of the pig-iron. On the other hand, grey pig-iron, although it requires a higher temperature for its fusion, passes at once from the solid to the fluid state without passing through an intermediate pasty condition. It is also more fluid when melted than white iron, so that immediately it melts it sinks at once below the covering of slag which collects upon the surface of the molten metal, and is thus protected from the oxidising influence of the blast, with a consequent delay in the completion of the fining process, and an increased consumption of fuel and waste of iron from oxidation, besides imposing additional labour upon the workmen engaged in the puddling.

448. *No decarburisation of the pig-metal* takes place until the graphitic carbon has entered into the state of combination or solution, or until all the grey iron has been converted into white iron; so that for dry puddling it is a usual practice to submit grey pig-iron to a preliminary treatment in the refinery for its conversion into white or refined metal before passing it to the puddling furnace, and the operation of puddling is always much accelerated by this previous treatment of the pig-iron in the refinery; whether the metal is to be subsequently treated either by the "dry" or "wet" divisions of the puddling process.

449. The process of puddling for the more or less complete removal of carbon, silicon, sulphur, phosphorus, manganese, and other foreign elements from pig-iron, and the conversion thereby of hard, brittle, cast-iron, containing from 3 to 10 per cent. of impurities, into a compara-

tively soft and ductile malleable iron, containing in its first stage as puddled iron (before piling) from one-half to 3 per cent. of impurities, was introduced by Cort in the year 1784; and, where mineral fuel is abundant, it has almost entirely superseded the older or open-hearth processes, from which it differs, as previously noted, in being conducted upon the bed of a reverberatory or other furnace in which the bed is separated from the grate upon which the fuel is consumed, and whereby the metal and fuel are prevented from coming into contact. The temperature required for the fusion of the pig-iron and its subsequent working is maintained by the flame and heat from the combustion of the gases produced by the fuel in the grate; so that raw coal and inferior fuels that cannot be used in the open-hearth finery are available for the puddling process; whilst by the adoption of gas furnaces, wood, brown coal, and peat, either alone or in conjunction with other fuels, are also applicable to the puddling operation; and thus the puddling process, which was formerly confined to districts affording coal at a cheap rate, can now be applied in districts devoid of coal, if they possess any of the classes of fuel just described, although coal constitutes by far the best and most suitable fuel, no matter whether it be for direct combustion on the grate or for conversion into gas to be burnt on the furnace hearth.

450. Notwithstanding that several patented and improved puddling furnaces and apparatus will be described in the subsequent pages, yet none of them are in general use, so that the puddling furnace and forge practice, as generally carried on at the present time, do not show during the past fifty years the same advancement as is manifested in the various other departments of the iron industry. The little modifications in the form of the furnace have been directed towards effecting an economy in fuel, but the largest economy has resulted from the increased output due to the more general use of basic fluxes in the furnace constituting the pig-boiling process; whilst the use of charcoal pig-iron and refined

metal have been mostly abandoned. And whilst the loss of iron was formerly about 16 per cent. of the charge, at present the average will be from 8 to 11 per cent., the consumption of fuel having decreased during the same interval to the extent of some 15 per cent.

451. As indicated in the preceding sections, the puddling processes are of two classes. In the older, or "dry-puddling," the oxidation of the elements necessary for the conversion of the pig-iron into malleable iron is principally effected by the oxygen of the air drawn by the chimney draught over the surface of the melted metal in the furnace, and assisted only to a smaller degree by the presence of oxidising fluxes or slags, technically termed *fettling*. In the more modern and, in point of production, by far the more important process known as "pig-boiling," or "wet-puddling," the oxidation obtained during the process is to a large extent effected by the various basic slags, cinders or scale, &c., added to the charge, the oxygen of the air playing only a secondary part in the reactions. Hence, in the pig-boiling process, the decarburisation being principally effected by the oxides of iron in the cinder or slag, and this reaction being the more active as the basicity of the cinder or its richness in oxide of iron increases; it follows that, during the earlier or melting-down stage, in which the silicon of the pig-iron is being oxidised by the oxygen of the atmosphere passing through the furnace, and the cinder produced is accordingly somewhat siliceous, there is almost an entire absence of decarburising influence upon the bath of molten metal; but as the process proceeds, and the proportion of silicon in the pig-iron becomes largely decreased, or almost *nil*, then the iron also becomes more rapidly oxidised, whereby the cinder speedily becomes more basic in its character, and the reaction between the cinder or slag and the combined carbon of the metal increases in activity, with the copious evolution of carbonic oxide and a correspond-

ing decarburisation of the metal, and the reduction of iron from the slag or cinder.

452. The *elimination of sulphur* from the charge is always very imperfect in the pig-boiling or wet method of puddling, a portion only of this element being separated and passing into the slag (tap-cinder), where it probably occurs as a sulphide of iron, although the exact form of its occurrence in tap-cinder is very uncertain; but the elimination of sulphur, as far as it goes appears to proceed somewhat steadily from the beginning to the end of the puddling process. The conditions favourable to the elimination of sulphur from the product of the puddling furnace are—1°, regularity of working; 2°, the presence of a good basic slag or cinder, which it is the object of the puddler to produce by the proper addition of a fettling rich in oxide of iron, oxide of manganese, lime, &c.; 3°, sufficient duration of the contact of the iron with the cinder before the commencement of the boil, and hence any delay in the process tends to the removal of a larger proportion of sulphur, as also of phosphorus.

453. The *elimination of phosphorus* is likewise imperfect, and the rationale of its separation is not clearly understood. However, the fact remains that about 80 per cent. of the phosphorus in the pig-iron under treatment passes out during the puddling process, and the tap-cinder produced at the same time always contains a considerable amount of phosphoric anhydride (P_2O_5) (see analyses, p. 280), and it is suggested by Dr. Percy* that probably the phosphorus first liquates as a liquid phosphide of iron from the metal when it is in the pasty condition, and that it is subsequently oxidised to the condition of phosphoric anhydride. The examinations of the slags, &c., made in Silesia (p. 279) indicate that during the melting down of the pig-iron the phosphorus in the metal is decreased by about one-third, and that subsequently its elimination goes on pretty

* "Metallurgy," Vol. II.

uniformly to the end of the process. It is found also that, as the proportion of silicon and phosphorus in the puddled product becomes lower, the proportion of carbon left in the malleable iron by the puddling process is usually higher.

454. *Manganese*, when present in considerable proportion, delays the fining of the pig-iron by preventing the breaking-up of the oxides of iron in the silicates of iron of the cinder added to the puddling furnace, and it thus also promotes the better elimination of sulphur from the puddled product. The analyses just referred to appear to indicate that the manganese is largely separated during the melting down stage, after which the elimination proceeds much more slowly, but it goes on again towards the close of the fining stage.

455. The puddling furnace employed in pig-boiling, as illustrated in Figs. 42—46, has a hearth of the form shown in Fig. 44, with a low flat arch or roof of fire-brick, *z* (Fig. 43), sloping gradually from over the front wall of the fireplace to the flue at the stack end of the furnace, and which in the small single furnaces is higher at the working side over the door (Fig. 46) than it is at the opposite side.

456. The *fire-bridge*, *a*, between the hearth, *c*, and the grate, *b*, is formed of a hollow cast-iron frame encased in fire-brick, while a similar bridge, *n*, across the other end of the hearth is known as the *flue bridge*, and separates the hearth from the flue and the stack, of which the stack, *y*, is built of common red bricks lined with fire-brick, and varies much in dimensions according as it is connected with one or more furnaces, but for one furnace only it ranges from 30 to 50 feet in height, and is strengthened as shown, by angle-irons up each corner, and well braced together by tie-rods passing around the stack. The stack is surmounted by a damper connected with a lever and chain, the latter brought down within reach of the puddler that he may regulate the draught as required during the working of the process. The outer,

or the side and end walls of the furnace, are enclosed within strong cast-iron plates, *d, d* (buckstaves), bolted together

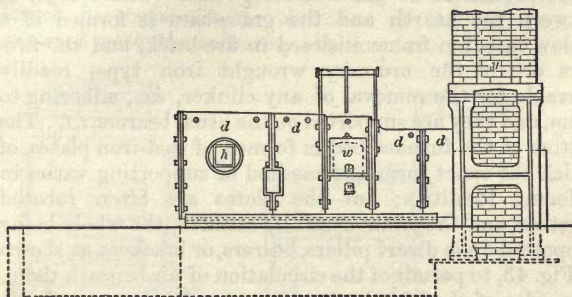

Fig. 42.—Front Elevation of Puddling Furnace.

through suitable flanges, and the plating of one side is connected with that on the opposite side by tie-bolts or rods, passing from side to side over the top of the furnace.

457. The *hearth, c*, in the pig-boiling furnace is about

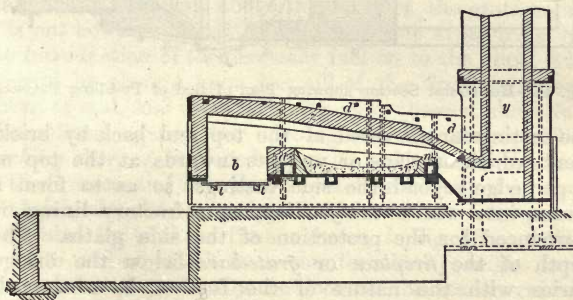

Fig. 43.—Vertical Longitudinal Section of the Puddling Furnace.

6 feet in length, but it differs in depth, form, and in the nature of its lining, according as pig-boiling or dry

puddling is to be conducted thereon. It measures about 3 feet 9 inches in width at the fire-bridge end, and 2 feet 9 inches at the flue-bridge end. The *bridge*, *a*, between the hearth and the grate-bars is formed of a hollow cast-iron frame enclosed in fire-brick, and the fire-bars are of the ordinary wrought iron type, readily movable for the removal of any clinker, &c., adhering to them, and they are supported on the usual bearers, *t, t*. The bottom of the furnace bed is formed of cast-iron plates, of which the exact form and method of supporting varies in different localities; but the plates are often rebated together, and the joints carefully caulked, the whole being supported upon dwarf pillars, bearers, or brackets, as shown in Fig. 43, to permit of the circulation of air beneath them. The sides of the hearth also are variously constructed, but are often formed of hollow castings permitting of their being kept cool by the circulation of air through them;

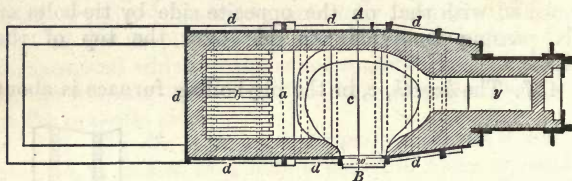

Fig. 44.—Horizontal Section showing Plan of Bed of Puddling Furnace.

the castings are covered at the top and back by brick-work, which overlaps or projects inwards at the top or upper edge beyond the side castings, so as to form a recess into which the *fettling*, or refractory lining, is introduced for the protection of the side plates. The depth of the *fireplace* or *grate-bars* below the bridge varies with the nature of the fuel to be consumed, a greater depth being required for slightly bituminous coals. But the best fuel for the ordinary grate is a non-caking coal containing but little sulphur, and which burns with the production of a long flame that thus plays

over the whole length of the furnace hearth. The area of the grate-bars is made from one-third to one-half of the area of the bed, being thus considerably larger in proportion to the area of the bed than is required with the reheating, balling, or ordinary rever-

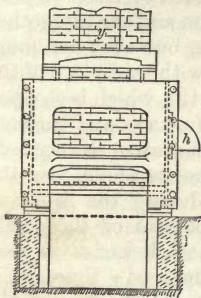

Fig. 45.—End Elevation of Puddling Furnace.

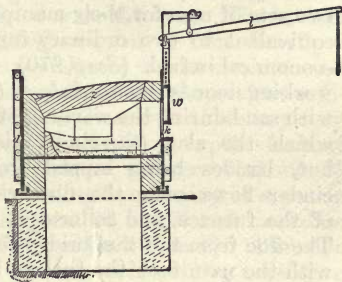

Fig. 46.—Transverse Section of Puddling Furnace on line A B, Fig. 44.

beratory furnace. The *firing-hole*, *h* (Figs. 42, 45), is placed in the front or working side, with its sill-plate about 10 inches above the level of the grate-bars ; it is not however closed by any door, but after firing or the introduction of the necessary fuel on to the grate, it is stopped by placing upon the sill of the fire-hole a few lumps of coal, and then throwing over these a shovelful of small coal against the opening into the grate. The *working door*, *w*, is placed some 10 inches above the bed of the furnace, and it is closed by a door formed of a large fire-brick tile, slab, or quarry fixed in an iron frame, and suspended by a chain from a lever, *l* (Fig. 46), at the opposite end of which is a counterbalance weight and suspended chain, whereby the door can be readily raised and lowered for the introduction of the charge and withdrawal as required of the puddled balls, and for these purposes only is the door used, the working of the charge being effected without opening the door by the puddler

introducing his bars or paddles through the small rectangular-arched opening or notch, *k* (Figs. 42, 46), called the *stopper-hole*, the sides or edges of which serve as a fulcrum for the rabblers during the stirring and working of the charge. In the large or double furnaces there are two working doors, one on each side, but such furnaces require two sets of men for their manipulation and are altogether equivalent to two ordinary furnaces, but they are more economical in fuel. (*Seep.* 270). Below the sill-plate of the working door is the *tap-hole*, *m* (Fig. 42), which is stopped with sand during the working of the furnace, and through which the slag (tap-cinder) is withdrawn as needed; but, besides being tapped from the tap-hole, *m*, the cinder flows over the flue-bridge during the working of the furnace, and collects at the bottom of the stack. The flue from the flue-bridge to the stack varies in area with the nature of the fuel to be employed; thus, while for the consumption of bituminous coal the area of the flue requires to be about one-fifth of the superficial area of the grate-bars, for the use of anthracite coal the sectional area of the flue is made but one-seventh of the area of the grate.

458. In some furnaces, in addition to the working hearth, there is also a second bed or hearth, situated beyond the flue-bridge, and between it and the stack. This second hearth serves for heating the pig-iron previous to placing it upon the working bed. In such furnaces the second bed is heated either by the flame on its way to the stack, after passing over the working bed; or in other furnaces, such as those heated by gas, the gases are burnt on the second hearth by the aid of a hot-blast, the blast being heated by passing the air through the hollow blocks of the sides of the working hearth, and then through a coil of pipes between the furnace and the base of the chimney, before they enter the second hearth for the combustion of the gases.

459. The *working bed*, *v* (Fig. 43), or lining of the hearth of the puddling furnace was formerly made of

sand when dry puddling only was pursued, but for "pig-boiling" or "wet puddling" the lining is made of those refractory substances rich in the oxides of iron, such as tap-cinder or hammer-scale mixed with the broken-up old bottoms of the puddling furnace, such matters aiding by their oxidising character in the conversion of pig-iron into malleable or wrought iron. The bottom is prepared by first introducing on to the hearth a layer of broken slags, tap-cinder or hammer-scales, and of hearth bottoms, and then raising the temperature sufficiently to fuse or soften these materials that they may be spread over the bottom to a uniform depth of about 3 inches; and upon this is placed a layer of about $1\frac{1}{2}$ inch in thickness of a "fettling" consisting of a nearly pure oxide of iron, in the form of a soft red hæmatite known by the name of "puddler's mine." The side plates are also fettled or covered with a lining consisting of *roasted tap-cinder*, or "bull-dog," as it is technically called, which is rammed well in under the projecting rib of brickwork or fire-clay slabs already spoken of as covering the top edge of the side plates. Practical puddlers attach considerable importance to the fettling being fixed as close and dense as possible around the furnace for the production of a cleaner iron. Like the bottom, the sides then also receive a coating of puddler's mine; or, instead of the "bull-dog" previously mentioned, other bodies rich in oxides of iron, as hæmatite, magnetite, or roasted spathic iron ore free from earthy matters, are also used for fettling the sides; and for a like purpose "blue billy" — that is, purple ore residues derived from the treatment of roasted cupreous Spanish and Portuguese pyrites by the wet process for the extraction of copper, and which residues contain about 96 per cent. of ferric oxide, with a little lead, copper, sulphur, calcium, &c.—is also used. The fettling of the side plates requires renewal or repair after the working-off of each heat, besides which, after every shift of twelve hours, sufficient scrap-iron is introduced into

the furnace to make a ball, which is worked up into a bloom, and during this operation a proportion of the metal is oxidised, thus giving to the bottom a further coating of oxide of iron.

ANALYSES OF THE MATERIALS EMPLOYED AS FETTLING FOR
THE PUDDLING FURNACE.

	Bull-dog.	Purple ore.	Pottery-mine.
Ferrous oxide . . .	3.55	—	46.53
Ferric oxide . . .	63.90	95.10	—
Manganous oxide . . .	—	—	2.54
Silicon	15.75	—	—
Titanic acid	10.89	—	—
Phosphoric anhydride93	—	0.69
Carbonic anhydride . . .	—	—	30.77
Sulphur	0.35	0.07	—
Sulphuric acid	—	—	0.04
Iron pyrites	—	—	0.34
Copper	—	0.18	—
Lead (as sulphate) . . .	—	1.29	—
Lime	—	—	2.41
Calcium	—	0.49	—
Alumina	—	—	0.97
Sodium	—	0.29	—
Magnesia	—	—	1.39
Insoluble residue . . .	—	2.13	2.27
Water and organic matter	—	—	11.93
	—	99.55	99.88

460. Other substances besides those enumerated in the preceding section are occasionally employed as *fettling materials*. A good fettling in addition to having the chemical qualities as above should also melt with a clear face, whilst such as crumble away, and thus tend to become mechanically mixed in an unfused condition with the metal of the puddled ball are objectionable, since it is exceedingly difficult, if not impossible, to expel such matters during the hammering or rolling of the bloom

into finished iron, and their presence produces, therefore, laminations of slag in the finished bar. Lime is sometimes used for fettling, but anything of a quartzose or siliceous nature is to be avoided, and the best material for the purpose is the *best tap*—that is, cinder from such reheating furnaces as work with cinder bottoms, and are employed in heating the wrought-iron piles for the rolling mills, but not the tap from the reheating furnaces working with the ordinary brick bottom covered with sand. The use of best tap is said to afford good malleable iron even from the poorer pig-irons, and to yield a greater weight of balls or puddled bars than the pig-iron operated upon, the difference being derived from the reduction of a portion of metal from the best tap.

461. Different fettlings* are, however, recommended, according to the class of iron to be produced; thus, with malleable iron for plates, sheets, bright or polishing iron, a good fettling is formed of best tap, covered with ground bull-dog; for merchant iron, sections, &c., rough pottery mine, covered with purple ore, affords a good fettling; while for hoop, strips, &c., good pottery mine, covered with a mixture of ground bull-dog and purple ore, is well suited.

462. The puddling furnace, when maintained in regular use, requires rebuilding after about six months' work.

463. The actual manipulation of the charge in the puddling furnace differs, according as white, grey, or refined iron, or a mixture of these with hammer-scale, &c., is under treatment; thus, when the charge consists of white or forge pig-iron alone, a higher temperature is desirable at the commencement of the process than is necessary when grey iron is under conversion. But the "pig-boiling" operation may generally be divided into four stages, of which the first or *melting-down stage*, occupying about thirty-five minutes, effects a partial removal of the *silicon* of the pig-iron, and converts any grey into white

* Edwards' Paper before the South Staffordshire Institute of Iron and Steel Works' Managers, 1883.

iron by changing the graphite to the condition of combined or dissolved carbon, the latter conversion being very essential, since it is only upon non-graphitic carbon that the oxygen of the atmosphere, and of the oxides of iron in the cinders, &c., is appreciably effective as a decarburising agent. In the *second stage*, lasting about seven minutes, a comparatively low temperature is maintained in the furnace, by lowering the damper in the chimney; and the charge requires to be thoroughly mixed with the oxidising fluxes or cinders added to the furnace, the puddler during this stage drawing down the metal from around the sides, where it is more rapidly fined, and mixing it with the more fluid metal and cinder in the middle of the hearth. But during the *third stage* the damper is raised, whereby the temperature is increased considerably, and violent reaction ensues, marked by the copious evolution of carbonic oxide, which, escaping through the slag on the surface of the metal, gives rise to the appearance of *boiling*. This stage lasts for about twenty or twenty-five minutes, and during this period of the pig-boiling process a large proportion of the manganese, sulphur, and phosphorus contained in the pig-iron is eliminated from the charge, their oxidation being promoted by the constant stirring or rabbling of the metal, whereby fresh surfaces are exposed to the oxidising influence of the oxygen of the air, and of the basic slags and cinders added to the charge; while at the same time there is produced a fusible slag or cinder consisting of the silicates of iron and manganese, but containing also phosphoric anhydride, earthy matters, &c. As this stage draws to a close, the ebullition gradually subsides, and the surface of the charge "drops," as it is called, and the whole mass lies in a pasty state on the bed of the furnace, where it is worked as thoroughly as possible by the puddler, so as to allow the flame to play uniformly over all parts of the charge. The *fourth* and last, or *balling stage*, occupies from fifteen to twenty minutes, and consists in breaking up the contents of

the furnace into some half-dozen balls, which are each rolled towards the fire-bridge of the furnace to receive a final welding heat before being withdrawn to the steam hammer, helve, or squeezer for the expulsion of slag and the production of puddled bar. During the conduct of these four stages of the pig-boiling process the damper is raised and lowered several times, as required for the regulation of the heat, and also for adjusting the amount of air passing through the furnace.

464. Supposing the furnace hearth to be hot from the working-off of a previous charge, and to contain also some of the rich cinder produced during the last heat, the puddling or pig-boiling process is commenced by first fettling the sides of the furnace in the manner already described (p. 259), and then introducing through the working door of the furnace a charge of about $4\frac{1}{2}$ cwts. of pig-iron; for it is not usual in pig-boiling to add much, if any, refined iron to the charge. The charge having been thus introduced on to the furnace bed, the working door is lowered, and if necessary made comparatively air-tight by luting it around the edges. The damper is now raised, the fire-hole opened, and more coal added to the grate. The fire being thus made up, the fire-hole is again stopped by lumps of coal covered over with coal slack as before, and after an interval of about fifteen minutes the metal begins to soften, and the puddler then inserts his rabble or bar through the stopper hole in the lower edge of the working door, turning over the pigs of metal so as to heat them and the hearth bottom more uniformly; and as the metal melts he also draws down any portions of unmelted metal from the sides towards the middle of the hearth. In from thirty to thirty-five minutes from the commencement, the *melting-down* stage is complete, whereupon the damper is lowered, and the melted or pasty metal is briskly stirred to thoroughly incorporate it with the oxidising cinder, while hammer-scale or mill-cinder is added to increase the basicity of the slags, as also to combine with the silica

resulting from the oxidation of the silicon of the pig-iron, as well as that introduced into the furnace in the form of sand, which always adheres more or less to the pig-iron as received from the blast furnace. When the charge has thus become covered with slag or cinder, the damper is again raised and the temperature thereby increased, so that in about forty-five minutes from the commencement of the process the metal swells and rises rapidly, presenting at the same time the appearance of boiling, due to the escape of the carbonic oxide resulting from the oxidation of the carbon in the pig-iron by its reaction with the oxides and silicates of iron contained in the basic slag covering the metal in the furnace. These decompositions are promoted during this stage by the vigorous rabbling of the charge by the puddler. He constantly moves the metal from the centre of the hearth towards the bridges, whilst at the same time cleaning well around the sides of the furnace.

465. During the *boiling period*, which continues about fifteen minutes, the escaping carbonic oxide (CO) burns at the surface of the bath with its characteristic blue flame, and as the decarburisation thus proceeds the mass begins to stiffen, the boiling decreases, the cinder gradually falls or "drops," and the metal "comes to nature" as it is termed, a condition indicated by the appearance of malleable iron in the form of bright points or specks on the surface of the charge, the points as the process proceeds increasing in size and collecting into pasty masses, when the contents of the furnace are again broken up and mixed by persistent rabbling, and any pasty lumps observed to be sticking to the furnace sides are detached and drawn down towards the centre of the bed, when the heat is again raised somewhat, so as to thoroughly liquefy the slags or cinder, and so promote their separation from the metal.

466. The *last, or balling stage*, then ensues, during which the workman detaches a portion of the pasty metal and rolls it over the surface of the furnace bed,

until it has in this manner collected to itself sufficient metal to form a ball weighing from 60 to 80 lbs., and possessing sufficient cohesion to bear removal from the furnace. Each ball, as it is thus formed, is rolled towards the fire-bridge, where it lies as little exposed as possible to the oxidising current of atmospheric air passing between the working door and the chimney. After the whole charge has been thus collected into some six balls, a final heat is given, after which the balls are withdrawn one by one through the working door of the furnace, by the workman seizing each with a pair of strong tongs and dragging it on to a two-wheeled bogie or truck, which is level with the sill-plate of the furnace and standing to receive the ball. It is then wheeled to the hammer, squeezer, or other shingling apparatus, where its particles are welded together into a comparatively solid mass, attended by the copious expulsion of slag and cinder during the compression. During the withdrawal of the balls the damper is lowered somewhat, so that a smoky, non-oxidising flame is maintained within the furnace, and the metal suffers but little, therefore, from oxidation and waste during this operation; but if the puddled balls remain too long in the furnace the quality of the metal is greatly impaired, although from what cause is not clearly understood.

467. The manipulation and procedure observed in the puddling process vary somewhat according as grey or white iron is the subject of operation. Thus with grey iron the pigs are charged and piled near the fire-bridge of the furnace, and as the temperature rises they are drawn down by the workman to the centre of the hearth, and there forced beneath the surface of the fluid slag; but, as before mentioned, grey pig-iron, owing to the higher temperature required for its fusion and its extreme fluidity when melted, is not so suitable for conversion into malleable iron by puddling as white iron, which melts at a lower temperature, and is not so fluid when melted. Grey iron sinks down, forming a fluid bath

beneath the molten cinder, and so prolongs the process by preventing contact with the oxygen of the air and of the fining of the metal, unless it be very persistently rabbled so as to constantly bring fresh portions under the oxidising influence of the atmosphere and of the basic cinder; hence the utility of refining or converting grey into white iron before introducing it into the puddling furnace. When white or refined iron is to be treated, the furnace is brought to a higher temperature before the charge is introduced than is desirable when grey iron is to be operated upon; and the charge of white iron is thus melted more rapidly, passing, before complete fusion takes place, through a pasty state favourable to the oxidation of the elements carbon, silicon, sulphur, phosphorus, manganese, &c., which it is the object of the puddling process to remove.

468. Upon a new furnace bottom it is not usual to charge grey pig-iron, but for the first heat the charge is made up chiefly of scrap-iron or waste-blooms and refined metal, so that by working such a charge at the high temperature of the furnace, and in the oxidising atmosphere prevailing therein, the bottom becomes consolidated and coated with a layer of slag consisting largely of the oxides of iron, which are but little acted upon by the silicon of the pig-iron introduced in subsequent charges. But if grey pig-iron containing much silicon be introduced on to a new bottom as a first charge, the silica resulting from its oxidation acts rapidly upon and unduly destroys the bottom.

469. The *tap-cinder* (for analyses, see pp. 279, 280), as the slag produced during the puddling process is termed, is only tapped out into wrought-iron waggons after the withdrawal of the last ball of every second heat. A "heat," it may be noted, is the time occupied between charging the pig-iron and drawing the last ball of malleable iron from the furnace, and is generally of about $1\frac{1}{2}$ hour in duration; but it may be longer or shorter according to the purity of the original

pig-iron, and also whether grey, white, or refined iron is under treatment; while the presence of sulphur or phosphorus in the materials of the charge, especially the last mentioned, considerably prolongs the puddling process. The cinder expelled from the puddled balls during shingling is almost invariably poorer in iron and richer in silicon and phosphorus than the cinder which remains in the furnace after the withdrawal of the balls.

470. The loss in the puddling process necessarily varies much according to the purity of the pig-iron, for since carbon, silicon, sulphur, phosphorus, manganese, and other foreign ingredients of pig-iron are more or less completely removed during the process, it follows, other conditions being the same, that the loss will be greater the larger the proportion of these elements present in the original pig-iron; but the loss also varies very much with the skill of the workman. An indifferent workman by neglecting his fire-bars and the firing produces thereby an irregular temperature, while by rabbling carelessly some portions of the iron are wasted and others are not brought into contact with the fettling for the decarburisation of the metal; and thus an inferior product is obtained, which contains sensible proportions of phosphorus and makes a loss of as much as 10 per cent. of metal in the furnace. A good puddler, working upon the same charge, will lose only 5 per cent. or less, producing also a better iron more free from phosphorus. The loss is greater, however, in "pig-boiling" or "wet puddling" than in the old method of "dry puddling," but it is less in the former process than the combined losses of the preliminary refining and subsequent puddling of the refined metal by the dry method. The loss is also greater in the conversion of grey than of white iron. In Staffordshire the loss between the pig-iron charged and the puddled ball produced, is from 7 to 10 per cent. of the metal introduced, whilst in the Scotch furnaces using a siliceous pig smelted from Blackband iron-ores, it amounts to from 15 to 18 per cent. of the pig-iron operated upon.

471. The charges employed in Staffordshire for single furnaces weigh from 4 to $4\frac{1}{2}$ cwts., and a puddler with his assistant will work off from five to seven heats in the shift or turn of twelve hours, according as the metal is grey, white, or refined metal; the coal consumed at the same time is about 20 cwts. per ton of puddled bars produced, and the fettling employed upon the furnace during one shift will run from 6 to 7 cwts. of "bull-dog," with from 2 to 3 cwts. of puddler's ore or of "blue billy." In Belgium the loss of metal is from 7 to 10 per cent., according to the purity of the pig-iron that is being used, and the consumption of fuel is also about 20 cwts. per ton of puddled bars produced. In Scotland, however, in furnaces working upon grey pig-iron, usually rich in silicon and puddled without any previous refining, the charges of the furnace weigh only about 4 cwts., and but from four to five heats per turn of twelve hours can be worked off: hence the consumption of fuel and loss of metal are both somewhat excessive, the former amounting to about 25 or 26 cwts. of coal per ton of puddled bars produced, and the loss amounts, as we have seen, to from 15 to 18 per cent. upon the pig-iron introduced into the furnace. In the Cleveland district the consumption of coal amounts to from 24 to 27 cwts. per ton of puddled bars, but the highest consumption of fuel per ton of metal yielded by the puddling process is afforded by certain of the Yorkshire forges, as those of **Bowling**, **Farnley**, and **Low Moor**, where it amounts to about 30 cwts. per ton of metal. In these forges, however, a superior class of iron is produced from cold-blast pig-iron, and the procedure observed as also the arrangement of the furnaces is somewhat different to that last described, inasmuch as the bed of the furnace is considerably smaller, and a higher stack is employed whereby a stronger draught prevails through the furnace. The charge of pig-iron at the above works is usually first refined and also reheated previous to its introduction

on to the hearth of the furnace. The charge weighs only from 2 to $3\frac{1}{2}$ cwts., and occupies from twenty to twenty-five minutes for the completion of the melting-down stage. From the commencement to the end of the process, when the charge is collected into three or four balls, the time occupied is about one hour and twenty minutes, so that nine or ten heats can be worked off during the shift of twelve hours. In these Yorkshire furnaces, also, the temperature is somewhat higher throughout the process than is observed in the Staffordshire district, whilst the rabbling or stirring of the molten metal is also more continuous. The puddled balls produced in the above-named forges weigh from 80 to 90 lbs. each, and are usually shingled under the helve into blooms, "stampings," or "nobblins," of 10 to 12 inches square and $1\frac{1}{2}$ to $2\frac{1}{2}$ inches in thickness, which are broken up under a guillotine, falling weight, or monkey, and the fracture is then carefully examined for the assortment of the metal into different classes available for various applications; thus the harder and more uniformly crystalline varieties are used in the manufacture of bars, whilst the softer and more fibrous qualities are used in the production of boiler-plates, wire-rods, and the like. For the latter purposes the slabs are placed in piles, reheated, and welded under the hammer into blooms or billets, which, after being again reheated, are finally passed through the rolls for the production of bars, angles, plates, &c.

472. The Bowling and Low Moor forges are worked under exceptional conditions, since beyond the special method pursued in the puddling and refining of the pig-iron in the manner just described, both the ore and fuel employed for the production of the pig-iron used in the forges are of a special class, found upon their own properties. The ore is an argillaceous brown ironstone containing about 32 per cent. of iron, or after calcination about 42 per cent. of metal, which ore

occurs in the Coal Measures of the locality; while the fuel employed is remarkably free from pyrites and sulphur, and is, further, a local material constituting what is known as the *better-bed coal*. The limestone used as the flux in the blast furnace is also obtained from Skipton in the same county. About 80 cwts. of raw, or 47 cwts. of the calcined ore, $2\frac{1}{4}$ tons of coke made from the above coal, and $18\frac{1}{2}$ cwts. of limestone are required for the production of 1 ton of pig-iron, which is smelted with cold blast, the metal being run direct from the blast furnaces into the refineries. The yield of these latter amounting to about 2 tons per charge is run out into plate metal in the manner already described, and the refined metal is then puddled in small charges, as just indicated, with the consumption of 30 cwts. of coal per ton of puddled bars produced.

473. **Double puddling furnaces** working proportionately larger charges than those previously described, and necessitating two sets of men for their manipulation—viz., one set for each side of the furnace, which is hence provided with two working doors, one on each side, through both of which the metal is simultaneously worked by the puddlers—have been received with considerable favour, although the metal produced is not likely to be so good and uniform in quality as that produced in the smaller single furnaces, owing to various causes: such as the disparity in skill between the workmen on the two sides, the furnace working hotter on one side than the other, the longer time that the charge is within the furnace (for double furnaces work more slowly than single), and the increased volume of air passing through such furnaces. But the double furnaces, owing to the larger charges of pig-iron—amounting to from 12 to 15 cwts. per heat, as against the 4 or $4\frac{1}{2}$ cwts. worked in the single furnaces—are attended with a larger output or production, and an economy in fuel and fettling also results. In them the hearth and grate area are both larger than in the single furnace, and the roof is (in this

respect differing also from the single furnace) of the same height above the bed at both sides, since both sides are working sides.

474. Beyond the materials already noticed, it is the practice in some works to add small quantities of Cumberland red hæmatite (consisting largely of ferric oxide) to promote the reactions of the boiling process. *Schafhautl's* powder, consisting of a mixture of common salt (sodic chloride), oxide of manganese (Mn_2O_4), and clay is occasionally introduced, to promote the better elimination of sulphur and phosphorus. *Scrap-iron* added towards the end of the boiling process is also considered, under favourable circumstances, to improve the product of the puddling furnace. The addition to the furnace charge of small quantities of a mixture of sodic bi-carbonate and lime, as soon as the pig begins to melt, appears to prevent a certain proportion of the waste of iron, especially if siliceous pig-iron is the subject of treatment.

475. For the older process, or "dry puddling," only white or refined iron is available, and hence the proportion of silicon in the metal under treatment is less than in the charges treated by the pig-boiling process, where mixtures of grey, mottled, and white iron are introduced into the furnace. The production of slag or cinder is therefore less in the dry than in the boiling process, and the necessity for the tapping out of cinder occurs only after the working-off of several heats, whilst the principal oxidising agent employed in the conversion of the pig into malleable iron by the dry process is the oxygen of the air, for, unlike the boiling process, no addition of cinder is made to the charge. The temperature employed in dry puddling is also lower than that required for pig-boiling.

476. The *furnace employed in dry puddling* is similar to that used in the boiling process, except that it is a little smaller and that there is an absence of all tap-cinder or of iron ore in the fettling or lining of the hearth. Formerly it was the practice to make the bottom of the furnace by simply covering the iron plates with a layer of sand,

which was then thinly glazed over with slag; but now, wherever the dry process is still pursued, the furnace bottom is covered with a lining of from 1 inch to $1\frac{1}{2}$ inch in thickness of oxide of iron, formed by working a ball of scrap-iron in the strongly oxidising atmosphere of the furnace, whereby sufficient oxide of iron is formed to afford the necessary lining, which is spread evenly over the bottom whilst the furnace is still at a high temperature.

477. The charge of white or refined iron is placed around the sides of the bed of the furnace, leaving the centre empty until the metal begins to soften or assume the pasty condition, when the damper is lowered to prevent it from becoming perfectly fluid. In its pasty condition the charge is then drawn down by the workman into the centre of the hearth, where it is broken up and rabbled, so as to thoroughly mix the metal with the oxide of iron produced by the oxidation of the iron whilst in the pasty state of the first or melting-down stage, as also with that now added to the charge in the form of hammer-scale. The rabbling is continued almost uninterruptedly from the running-down to the balling-up of the charge; whilst a reaction not less vigorous than in the boiling process ensues after the incorporation of the charge with hammer-scale, &c., whereby the carbon and impurities of the pig-iron are oxidised by the oxygen of the atmosphere and of the hammer-scale, and in consequence carbonic oxide escapes, whilst the other impurities of the pig-iron are oxidised, and largely enter the tap-cinder.

478. The progress of the decarburisation, "coming to nature," or "drying"—as the phenomenon is technically termed—of the charge, is indicated by the decreased fusibility of the metal, and other indications similar to those described under pig-boiling present themselves. This stage having been carried to the required degree, the damper is raised, and a higher temperature produced for the balling-up of the metal.

479. Owing to the smaller quantity of silicon and other impurities in the refined or white iron treated in dry

puddling, the duration of the process is shorter than in pig-boiling, the production of slag is proportionately less, and the expenditure of fuel is likewise not so great as in pig-boiling. Dry puddling is only economical in fuel so long as white or refined iron can be used, and the process is attended by a greater waste of iron than occurs in pig-boiling; whilst unless comparatively pure ores have been employed in the production of the pig-iron to be treated, the malleable iron resulting from this process is also inferior in quality; and hence dry puddling is not now generally employed, the practice of pig-boiling or wet puddling having largely superseded it.

480. The furnaces as applied to the puddling process, and employing *gaseous fuel*, differ in construction with the materials employed for the production of the gas, and also with the mode of its combustion, as shown by the following examples.

481. The Siemens Regenerative Gas-furnace, as applied to the puddling process, is similar in most respects to that (p. 445) for melting steel upon the open hearth, the *gas producers* being identical with those described (p. 363), whilst the construction and action of the *regenerators* are also the same (p. 373); and the furnace itself only differs in the formation of the bed, which is lined with a basic lining of iron oxides, bull-dog, &c., suitable for the puddling process, instead of with the acid or siliceous bottom (p. 446) for the steel-melting furnace. The Siemens Regenerative Gas-furnace effects an economy of from 20 to 30 per cent. in the consumption of fuel, and possibly an increase in the yield of malleable iron per ton of pig-iron introduced into the furnace, and it works off a greater number of heats per day; but it is not generally accredited with effecting the same degree of dephosphorisation and desulphurisation of the metal as is accomplished in the ordinary puddling furnace; whilst the product is also generally of a more or less steely character.

482. The puddling furnace of *Messrs. Caddick and Maybery*, working at Llanelly, in South Wales, affords an

example of what is essentially a gas-puddling furnace, worked in conjunction with a blast of warm atmospheric air. This furnace consists of a large grate or *gas generator*, built of fire-brick enclosed within a hollow casing of wrought-iron plates into which a blast of atmospheric air is delivered by a fan, whilst from apertures in the lower part of the casing the blast is admitted into the closed ash-pit beneath the grate-bars; and a supply of blast regulated by a valve also passes from the casing through an aperture into the generator above the level of the fuel, in which manner more complete combustion, a comparative absence of smoke, and a corresponding economy in fuel are effected. The blast is heated, previous to its meeting and burning the gases from the generator, by circulation around the body of the latter, whilst the portion which passes through the grate-bars is further heated by contact with the hot ashes in the ash-pit. The whole furnace is supported by iron plating and by buck-staves in the form of cast-iron columns, tied together over the top by suitable tie-rods; and the furnace being a double one has two working doors. Each working door is provided, as usual, with a stopper-hole for the introduction of the tools and working of the charge; and a constant circulation of air is maintained beneath the bottom of the furnace, which is thus effectually cooled and the consumption of fettling decreased. The furnace bed is fettled with iron-ore and mill-cinder, and the charge is worked without any addition of tap-cinder, the puddling being effected upon what is technically called a *dry bottom*, the slag being drawn off from the furnace as frequently as possible. This furnace is reported to afford a very considerable saving in fuel and in fettling, with an increased production of stamps or puddled bars per ton of iron charged into the furnace. The charge, it may be noted, weighs usually about 11 cwts., and is often made up of No. 3 hæmatite, with old scrap.

483. In Carinthia, Styria, Neustadt in Hanover, &c., gas-furnaces similar to that last described are also employed for the puddling process, wood, lignite, and turf respectively being the fuel usually employed. In these several furnaces a blast is heated by circulation through a hollow casing of the furnace, or, as in the Neustadt furnaces, by circulating through cast-iron chambers placed in the roof of the flue of the furnace, between the puddling hearth and the stack. The blast is thus heated to a temperature of about 200° C. (392° Fahr.), before it is introduced over the top of the fire-bridge by a broad inclined twyer, directed towards the body of the furnace. In these furnaces, besides the blast directed over the fire-bridge, a jet of air is usually delivered either between the grate-bars or near to the bottom of the gas generator, whereby a current of carbonic oxide is formed by the oxygen of the blast in its passage over the great mass of heated carbon in the deep, rectangular, gas-generating chamber; and the carbonic oxide so yielded meets with the heated air and, along with the other gaseous products from the generator, burns on the furnace bed. The generator or gas-producer of the Carinthian furnace, in which dried wood is the fuel employed, is a deep rectangular chamber with a capacity of about 14 cubic feet; it is built at one end of the hearth, from which it is separated by a suitable bridge; it is further usually provided with a second chamber between the bed and the stack, into which the charge of pig-iron is introduced for heating preliminary to its insertion upon the puddling hearth; this second chamber is heated by the waste gases from the puddling hearth on their way to the stack.

484. Proposals for the better adaptation of the puddling furnace for the *utilisation of small coal* and of *free coal* have been numerous, and amongst these may be noted that of Detmore, by which a blast of atmospheric air is introduced into the *closed ash-pit* of the furnace, whereby it is sought to utilise washed small coal as the

fuel. Another suggestion was to enable the puddling furnace to consume a mixture of half caking and half free-burning coal by the introduction of a blast into the open ash-pit; but these methods have not been received with anything like general favour.

485. Price's puddling furnace is a modified gas furnace working with a blast, and consists of a bed or hearth at one end of which is a chamber or *dandy* in which the pig-iron is first placed for preliminary heating; at the opposite end of the hearth are the grate-bars, as also a kind of closed chimney or stack enclosing a vertical chamber or retort of brickwork, the upper portion of the retort being formed of a massive iron casting surmounted by a charging hopper which serves also to close the upper end of the retort; while the slide, working in the bottom of the hopper, is connected with a lever and hanging rod so as to render it accessible to the workman at the floor level. At the lower end of the vertical retort is the stoking-hole to the grate-bars, and upon the dead or fore-plate forming the bottom side of the stoke-hole falls the coal which has been carbonised in the retort in the manner to be immediately described; from thence it is pushed forward by tools introduced by the workman through the stoke-hole on to the grate-bars, where it is consumed by a blast of heated air introduced into the closed ash-pit below the bars. Beneath the dead-plate is a brickwork chamber in which is fixed a heavy cast-iron air vessel, around which the heated gases circulate on their way from the retort chamber to the chimney stack. A blast of air at a pressure of about 6 oz. is delivered by a Lloyd's blower into the air chamber just mentioned, and from thence passes to the ash-pit beneath the bars. The flue of the furnace passes back over the top of the hearth, from the dandy or heating chamber at one end of the bed to the retort chamber at the opposite extremity, where the current of flame is split into two halves which circulate around the vertical retort, passing from thence downwards to the chamber containing the

air vessel previously mentioned, and then onwards to the chimney stack. In this manner the vertical retort is maintained at a red heat, so that the coal introduced through the hopper at its upper extremity is subjected therein to destructive distillation after the manner of an ordinary gas retort; the gases escaping from its lower end pass, owing to the chimney draught, towards the bed of the furnace, whilst on the grate situated between the bottom of the retort and the furnace bed there is kept a thick bed of coke, maintained in vigorous combustion by the heated blast of air admitted below the bars from the air chamber already named, and in this manner the gases from the retort are at once ignited as they pass over the burning coke; while also a proportion of carbonic oxide (CO), from the combustion of the thick bed of coke, is mingled with the gases from the retort, and is burnt with them on the puddling bed, filling the same with a large flame. The supply of coke to the grate is made from the descending carbonised fuel from the retort, which falls down as fresh coal is added at the top, and which, as it reaches the dead-plate, is pushed forward by the workman over the dead-plate on to the grate. The gases from the retort thus enter the hearth at a temperature of from 427° C. to 538° C. (800° Fahr. to $1,000^{\circ}$ Fahr.), whilst the combustion of the coke is maintained by a blast of hot air, and by these means a high temperature can easily be kept up. The heating of the blast of air, the carbonisation of the coal in the vertical retort, together with the preliminary heating of the charge of iron in the dandy, are all effected by the waste gases from the puddling hearth in their passage to the chimney, and a considerable economy in fuel is thereby claimed for this furnace, in which it is stated that $7\frac{1}{2}$ cwts. of coal with from $4\frac{1}{2}$ to 5 cwts. of fettling suffice for the puddling of a ton of pig-iron.

486. The Price Furnace is a double furnace working with a cinder bottom, and is fitted with an arrangement of doors, plates, &c., similar to those of the ordinary furnace,

and at Woolwich it has been fitted with Witham's puddling or rabbling apparatus. In the working of this furnace it is necessary to keep the retort properly charged with coal, and to observe that the coke is pushed forward on to the grate at proper intervals, otherwise the temperature will fall unduly, and a loss of fuel will result.

487. The charge for these furnaces adopted at Woolwich weighs about 14 cwts., and is made up of 5 cwts. of old shot, 5 cwts. of old shell, and 4 cwts. of gun-iron; and these materials after being first heated in the dandy occupy only about one hour and a-half for their fusion and conversion into puddled balls ready for drawing from the furnace.

488. The Ponsard regenerative gas-furnace is also employed in the United States; it has a rotating movable hearth, which can be withdrawn from the furnace and run under the tap-hole of the blast furnace from which it receives its charge of pig-iron. It is then replaced in position, when the flame from the combustion of the gases and air plays over the surface of the metal, the hearth being at the same time rotated by a small engine. The waste gases return under the bridge, and down to the outlets leading to the regenerators, before they pass away to the stack. The gas-producer or generator is a deep rectangular chamber built at the end of the furnace and its regenerators. (Fig. 88).

489. The Tap-cinder, or slag produced during the puddling process, is essentially a highly basic silicate of very indefinite proportions, varying in composition at various stages of the process, but always containing ferrous and ferric oxide, with manganous oxide, alumina, lime, magnesia, ferrous sulphide, phosphoric anhydride, and probably some phosphide of iron. Such cinders often yield from 45 to 55 per cent. of metallic iron, existing principally in the form of ferrous and ferric oxides. The basicity of the cinder is greatest towards the end of the process as the metal "comes to nature,"

since then the oxidation of silicon has been practically completed, whilst owing to the high temperature still prevailing within the furnace the oxidation or waste of iron continues. The cinder expelled during the shingling of the puddled ball is almost invariably richer in silicon and phosphorus, but poorer in iron, than that left on the bed when the balls are withdrawn from the furnace. During the melting-down stage of the puddling process, the cinder is the most siliceous, as is shown by the accompanying analyses, for during this stage the silicon of the pig-iron is being rapidly oxidised by the oxygen of the atmospheric air; also the silica in the form of sand attached mechanically to the pigs of cast-iron likewise passes at this stage into the slags, in combination with oxide of iron, &c.

490. The following are analyses* of tap-cinder taken at various periods of the puddling process in an Upper Silesian works, working upon a charge weighing $4\frac{1}{2}$ cwts. of a mixture made in the proportion of 24 cwts. of hæmatite pig to 20 cwts. of white iron.

ANALYSES OF TAP-CINDER.

	After complete fusion of charge.	Before end of refining.	At "coming to nature" of first ball.	Slag from hammer during shingling of first ball.
Silica	17·13	21·91	19·45	16·29
Ferrous oxide	59·06	46·76	48·04	51·62
Ferric oxide	9·81	12·36	13·48	19·32
Manganous oxide	9·35	15·87	14·40	8·46
Alumina	0·35	0·30	0·34	0·38
Lime	0·69	0·43	0·62	0·61
Phosphoric anhydride	3·40	3·10	4·17	3·78
Iron	52·80	45·02	46·79	53·67

* "Annales Industrielles," 1875.

ANALYSES OF STAFFORDSHIRE TAP-CINDER.

	Cinder from boiling of white iron* (Riley).	Staffordshire cinder* (Percy).	†	Cinder from pig-boiling.
Silica	7.71	23.86	12.63	11.08
Ferrous oxide	66.32	39.83	68.91	63.00
Ferric oxide	8.27	23.75	2.00	17.14
Manganous oxide	1.29	6.17	—	—
Alumina	1.63	0.91	} Not estimated	—
Lime	3.91	0.28		—
Magnesia	0.34	0.24	—	—
Ferrous sulphide	—	0.62	—	—
Sulphur	1.78	—	0.33	0.48
Phosphoric anhydride	8.07	6.42	0.63	8.20
Titanic acid	—	—	8.73	—
Metallic iron	57.37	47.60	—	—

491. The tools used by the puddler are not usually numerous, consisting only of a long straight chiselled-edged bar called a "paddle," and a hooked flat-ended bar known as the "rabble."

492. The Bicheroux furnace is a gas-furnace, having its own producer or gas generator, and a separate combustion chamber where the gases and air first meet and combustion commences, but the combustion is only completed upon the puddling hearth itself. These furnaces are without any regenerators, although heated air is supplied for combustion by circulating it before it mixes with the gas through a flue which extends below the bed of the furnace for its full length and breadth. This system of furnace has been applied on the Continent at Seraing, Ougrée, &c., to the puddling process ‡

* "Manual of Metallurgy," Vol. I.

† South Staffordshire Institute of Iron and Steel Works' Managers. Mr. R. Edwards' Paper.

‡ "Annales Industrielles."

for which purpose the gas-producer has parallel sides, is of about the same width as the hearth, and has a slightly inclined grate which is accessible from a pit in front of it, whilst the openings for charging the fuel into the generator or producer are four in number, and are closed either by fire-bricks or by lumps of coal. The furnace admits of the use of the smallest or even slaty coal, but the dimensions of the generator, mixing chamber and hearth require adjustment to suit the fuel used in various localities. The gas from the generator is conveyed by a short horizontal flue to a vertical slot in the front end of the hearth, where the heated air is also admitted through a number of small openings, and thereby almost perfect combustion of the gas is effected. The circulation of both the gas and air is obtained by a chimney draught, and after serving the furnaces the heated and any incompletely burned gases enter the boiler flues for raising steam in the usual manner. The puddling bed or hearth is somewhat larger than is usually adopted, and the furnace has two doors, one on each side.

493. It is claimed for the Bicheroux puddling furnace that it consumes considerably less fuel and of a much inferior class than the ordinary furnace, that the waste of iron is very greatly diminished, that the manufactured iron is of better quality, whilst the repairs are decreased, since the fuel and its ash do not come into contact with the hottest part or fire-bridge of the furnace.

494. What is known as Parry's process of double or treble puddling consists in taking iron which has been once puddled according to the ordinary practice, such as ordinary scrap iron, &c., and reconverting it into a kind of pig-iron, which is then again subjected to the puddling operations.

495. In the Parry process, scrap-iron, as crop-ends of rails, bars, &c., is taken and melted in a cupola with coke containing as little sulphur and ash as possible, whilst a judicious use of limestone, sodic carbonate, or

other flux in the cupola is recommended, to prevent the metal taking up any sulphur from the fuel; and to promote the recarburisation of the metal, the cupola is also provided with an inclined twyer in addition to the ordinary horizontal twyers. By this treatment the scrap-iron is partially recarburised, and leaves the cupola in a condition similar to the refined metal of the coke refinery. By again treating this recarburised metal in the puddling furnace, a product practically free from sulphur, phosphorus, and silicon, is obtained. The rationale of the process is based upon the fact already shown, that the puddling process ordinarily removes from 75 to 80 per cent. of the total amount of sulphur and phosphorus present in the pig-iron before its introduction into the puddling furnace; hence, by reconverting the puddled metal into pig or refined metal, which can be again treated in the puddling furnace, a further elimination to the extent of 75 or 80 per cent. of the remaining sulphur and phosphorus will be effected, and a puddled bar thus obtained which should be practically free from these elements.

496. **Malleable iron castings or malleable cast-iron** are the product of the treatment of cast-iron castings by a process of cementation in which the cement powder is a decarburising material, such as powdered red hæmatite iron-ore; but despite the many practical improvements effected of late years in the production of malleable iron castings, yet the chemistry of the subject is by no means either clear or certain, for while authors generally accept the process as one by which carbon, silicon, sulphur, and manganese are removed from the surface of the pig-iron by a *process of oxidation*, others, like Mallett, Forquignon,* &c., dispute this theory. The last mentioned attributes the change in the physical properties of the castings before and after treatment to the *separation of amorphous graphite* within the metal, without which separation he states that the carbon

* "Annales de Chimie et de Physique," 1881.

may be decreased in amount whilst the article will still remain brittle; he further considers that whenever oxidation really takes place it is only accessory, and not the primary cause of the change. Whatever may be the rationale of the process, the result of the treatment is the production of a dull grey, soft, more or less tough, strong and flexible material, void of the brittleness characteristic of the castings made of white cast-iron, and more nearly resembling in physical qualities either wrought-iron or soft steel, especially in the smaller castings; but with large castings, or such as have a thickness exceeding 2 inches, the malleable castings are not so reliable as is the smaller work.

497. Malleable cast-iron does not weld, since in all except the very thinnest castings, although the surface has been converted into a malleable form, there remains an inner core which at the temperature required for welding falls to pieces immediately the object is struck with the hammer; but good specimens may be bent double when cold, although they rarely permit of being straightened back again without breaking. The metal can also be forged to a limited extent at a moderate red heat, although if heated above this point it falls to pieces under the hammer. Specimens may also be burnt together at a temperature approaching fusion, or may be brazed with hard solder to either iron or steel. Malleable iron castings frequently take a polish under emery, not, however, nearly so well as steel; and although the articles may be filed, fitted, or turned in the lathe, they wear away the tools somewhat more quickly than wrought-iron under like circumstances, so that malleable cast-iron thus occupies a position intermediate between grey iron on the one hand and steel upon the other; differing from the former in possessing a higher tenacity, with increased toughness and flexibility, but differing from steel in having a lower ductility, inferior tenacity, and in containing graphitic carbon.

498. The castings intended for conversion are cast in

moulds of dry or of green sand of the common construction, except that owing to the higher temperature at which the metal is cast, fire-clay is used instead of the ordinary parting sand of the moulder. Further, the gates and runners are made small, flat, wide and thin, especially when casting small articles, since white iron (from which the castings are made) sets so rapidly that unless the gates are made light and thin the casting is liable to fracture itself at its junction with the gates and runners in a manner well understood by moulders.

499. For small articles the pig-iron is melted in crucibles, but for larger ones it is melted in the cupola with coke and air blast in the usual way. After preparation of the mould and running of the castings in the ordinary manner, they are removed from the moulds, and cleaned carefully by brushing or other means. The castings are then packed in cast-iron boxes or crucibles known as "saggers," but for special purposes and for large articles pots of wrought-iron are frequently employed. The castings, which, as removed from the moulds, are brittle and present a white crystalline fracture, are packed in the above pots in alternate layers with red hæmatite, such as that from Barrow or Cumberland, the ore being previously ground and sifted through a sieve of $\frac{1}{8}$ -inch meshes, the very fine powder being rejected. At each fresh charging a certain quantity of fresh ore or of fine iron scale from the rolling mills is mixed with the ore that has been once used, each casting being perfectly surrounded with ore and isolated from the other castings in the same pot. The pots are in this manner filled nearly to the top, when they are filled up with ore and covered each by its own cover. A number of these pots are then arranged in a rectangular furnace, heating chamber, or annealing oven, the pots containing the larger castings being placed in the hottest part of the furnace. The furnace having been thus charged, the temperature is gradually raised, and in about twenty-four hours it has attained to a

bright cherry-red heat, which is maintained for from three to seven days, according to the size of the castings and the quality or depth of decarburisation required. The strength of the malleable iron casting increases with the length of time during which it has been exposed in the furnace to the cementation process, but such increase is much more rapid in the earlier than the later stages, when the process proceeds more slowly, and in all cases the softening is more successful with small than with large castings. After the necessary exposure in the furnace, the pots are withdrawn and allowed to cool down before removing the castings, which now only require cleaning to clear them of the adhering hæmatite when they are ready for use.

500. All pig-irons are not equally well adapted to the production of castings suitable for conversion into malleable iron castings, the use of grey and manganiferous pig-iron being especially to be avoided; whilst the most suitable pig-iron for the purpose is white or mottled charcoal-iron smelted from hæmatite ores, the former being preferred for large castings and the latter for smaller work; but hæmatite pig-iron smelted with coke is frequently employed. The pig-iron is, as usual, often melted along with scrap, such as gates, runners, fins, waster castings, &c., of white iron.

CHAPTER XV.

MECHANICAL PUDDLING AND ROTARY PUDDLING FURNACES.

501. **Mechanical Rabblers** of various forms have been proposed to aid or supersede the manual labour required from the puddler, for probably there is no department in the metallurgical treatment of iron or steel which is more arduous and exhausting than that of the puddling

process ; and to minimise this, as also to obtain a more homogeneous product from the furnace, mechanical rabbles of different descriptions have been proposed. Of these probably one of the most promising is that patented by Mr. Pickles, which is in use at the Kirkstall Forge, and which like most of these mechanical appliances is generally applied to the working of double furnaces, although it is quite possible to adapt it to the single furnace.

502. *The arrangement of Mr. Pickles* consists of a small engine mounted upon a suitable framework above the top of the furnace, by the plating of which it is carried. A connecting-rod from the engine actuates a transverse lever or beam, which thus oscillates in a vertical plane, and this movement is imparted to a bell-crank lever, to one arm of which the end of the beam is suitably coupled by a connecting rod, whilst the other extremity of the bell-crank lever comes down in front of the stopper-hole in the furnace door, and thus gives a to-and-fro motion to the rabble, which it moves within the furnace. The long end of the bell-crank lever is attached to the end of the ordinary rabble, inserted as usual through the stopper-hole of the furnace door, while a further motion is given to the bell-crank and so to the rabble by centring the bell-crank upon a radial arm which can be rotated by a worm and worm-wheel. In this manner it derives a radial or circular motion through a definite arc of a circle and thus the end of the rabble receives a sweeping or circular motion over the bed of the furnace besides the first mentioned to-and-fro movement from the stopper-hole to the opposite side of the furnace. Both movements are effected without any labour from the puddler, and the rabble, thus receiving automatically a vertical reciprocating motion and also a lateral radial motion, traverses all parts of this furnace bed and accordingly thoroughly stirs the charge.

503. A similar apparatus to the above has been devised by *Mr. Eastwood*, in which the rabble is connected by a kind of stirrup with one end of a bent lever working

around a fulcrum fixed overhead and which, as in the arrangement of Mr. Pickles (except by somewhat different mechanism), receives a reciprocating motion across the furnace through a crank, and a lateral movement through a worm and worm-wheel gearing, whereby the rabble is the recipient of a compound motion which has the effect of working it over the whole surface of the bed of the furnace. Other and analogous forms more or less successfully applied to special furnaces are those of *Griffiths* and of *Whitham*, whilst a simple arrangement of a four-pronged rabble passed through the roof of the furnace, and simply revolved in the bath of the metal on the hearth, was proposed by *Morgan*.

504. In other forms of the mechanical rabble, the tool is hooked on to a drop rod and is simply guided by the puddler, while the machine does all the heavy work.

505. *Mechanical rabbles*, although intended to considerably diminish the labour of the puddler, are not, however, applicable to the balling-up of the charge, which has still to be done by the fore-hand at the furnace, and the weight of the charge is accordingly still limited by the power of the workman to ball it up. Mechanical rabbles have not, therefore, come into general use, although they enable the puddler to work somewhat larger heats, and occasionally to effect a slight economy in the working.

506. Besides the various proposed mechanical rabbles designed to relieve the puddler of a portion of the very arduous labour attending the manipulation of the puddling process, revolving furnaces, in which the hearth consists of a revolving cylinder rotated by steam power, have also been introduced somewhat extensively. They were expected to produce malleable iron more economically, and of greater homogeneity than by the older fixed furnaces, but these expectations have up to the present been only very partially realised.

507. The *introduction of revolving furnaces* appears to date from the Messrs. Walker and Warren's furnace of

1853, succeeded by Maudsley's in 1858, and by Tooth's in 1861. The last mentioned consisted of a revolving wrought-iron cylindrical chamber, lined with fire-clay, and placed between the grate-bars and the chimney. An improved form of this furnace was introduced by Mr. Menelaus, in which an elliptical chamber was substituted for the cylindrical one, but the failure of this and the previous revolving furnaces is attributed largely to the difficulty of

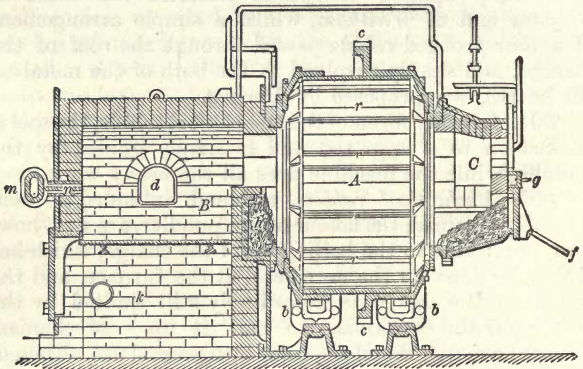

Fig. 47.—Vertical Section through the revolving Chamber and the Flue of the Danks Puddling Furnace.

preparing a suitable lining. Among the more or less successful forms of revolving hearth of more recent date are those of Danks, introduced in 1869, of Sellers and Siemens, each in 1871, and of Crampton, in 1872 and 1873. In these furnaces the hearth revolves in a vertical plane, whilst in others, as in those of Pernot, Godfrey and Howson, &c., it rotates in a plane either horizontal or only slightly inclined to the horizontal.

508. The Danks rotary puddling furnace, though very favourably reported upon by a commission of the Iron and Steel Institute, and somewhat largely introduced into the forges of this country some fifteen years

ago, has not been attended with sufficient commercial and practical success to induce British ironmasters to take it up, although it is reported to be in successful operation in America.

509. The Danks furnace consists of a fixed grate, a revolving chamber or hearth, and a movable flue-piece between the chamber and the stack. The grate is in nowise novel, except that it is supplied by a blast of atmospheric air, delivered in a series of jets above the surface of the fuel, and whereby a more complete combustion

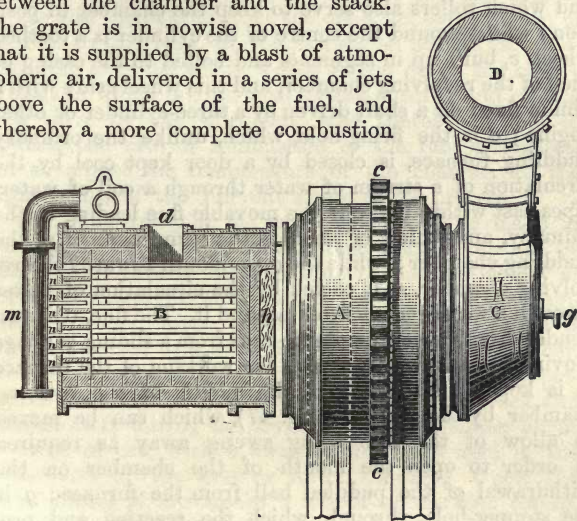

Fig. 48.—Plan of the Danks Revolving Puddling Furnace, half in Section.

of the gases from the fuel on the grate-bars is effected, while the ash-pit is also closed by folding doors, and into it a blast of atmospheric air is also introduced.

510. The revolving hearth, A (Figs. 47, 48), consists of a cast or wrought iron cylindrical chamber with conical ends, the shell being built up in segments, bolted or riveted together according as it is made of cast or of wrought iron; while in the inside and across the casing from the fire-bridge to the flue end, are fixed some twelve ribs, *r, r,*

which aid in holding in the *fix* or fettling of the furnace. The one end of the revolving chamber is open to the fireplace, B, whilst the other opens into an elbow-shaped movable flue, C, leading to a fixed chimney, D. The cylindrical chamber, A, is encircled towards either end by a roller path, which rests upon four friction rollers, *b, b* (Fig. 47), and which rollers also serve to keep the chamber in position; whilst around the centre of the cylinder is a toothed wheel, *c*, built up in segments and bolted to the casing or shell of the revolving chamber, and this wheel gears with a pinion fixed on a shaft driven by a three-cylinder or other engine; *d* is the firing-hole, which, unlike the ordinary puddling furnace, is closed by a door kept cool by the circulation of a stream of water through a coil of water-pipes cast within it. *e* is the movable flue leading to the chimney, and which is lined in the same manner as the puddling chamber; while the open mouth towards the revolving chamber, A, is cooled by the circulation of water through a water-jacket fitted around it. The flue, *e*, is suspended from above by suitable rods from a sliding carriage moving on rails, whilst during the working of the furnace it is kept in contact with the mouth of the rotating chamber by the rods, *f* (Fig. 47), which can be moved to allow of the flue being swung away as required in order to open the mouth of the chamber on the withdrawal of the puddled ball from the furnace; *g* is the stopper-hole, through which the reaction and progress of conversion within the furnace can be observed, and through which the puddler inserts his tools. The cast-iron bridge, *h*, contains a coil of pipes, through which a current of water circulates for cooling purposes, and the bridge is faced with fire-brick on the side towards the grate-bars, and with fettling like the furnace itself, on the side towards the revolving chamber. At the front or fire-bridge end of the puddling chamber, there is fixed an iron annulus or jacket, through which a current of water flows, so as to keep the neck cool, and thus prevent the fettling around the throat of the

revolving chamber from cracking and breaking down, by the expansion and contraction under the great range of temperature to which it is subjected, during the introduction and working of the charge, and withdrawal of the puddled ball. The closed ash-pit, *k*, is supplied with a blast of atmospheric air from a fan, and jets of air are also introduced from the main, *m*, over the top of the fuel on the bars, by the twyers or nozzles, *n*, *n*, *n*, extending over the whole width of the grate, the supply of blast to which is controlled by the opening and closing of a valve by the workman, who thereby is able to regulate the rate of combustion of the fuel and gases, and so adjust the temperature of the chamber to the requirements of the different stages of the process.

511. The *lining of the revolving chamber* is made in two stages, the first or initial stage being prepared by mixing iron ore with milk of lime to the consistency of mortar, and applying this paste to the inside of the cylindrical chamber, after which the lining so prepared is thoroughly dried by a wood fire made within the chamber. The lime employed for the initial lining should by preference be anhydrous, otherwise it is likely to crack and crumble away during the drying. In this manner about 30 cwts. of ore, with 4 cwts. of lime, are used in the preparation of the first or initial lining. Upon the initial lining is introduced a *second or working lining*, formed of the hydrated and, as nearly as possible, non-siliceous ores of iron, such as pottery mine, along with scrap-iron. These materials are thrown into the furnace, and there melted upon the initial lining, forming what is technically known as *fixing*, and into this bath of melted ore or fixing, larger lumps of cold ore are thrown, around which the fluid ore cools and sets, and fixes them in the lining, this operation being repeated around the cylinder until the whole inner surface is thus coated; while sometimes a second coating of fixing and lumps of ore is introduced to complete the fettling of the furnace. The slags and bull-dog used in the

ordinary puddling furnace as fettling materials are not available in this furnace, but "blue billy," certain hæmatites, ilmenite, or mill-scale melted along with scrap balls, can be so employed; but where suitable ores are not available, the best tap-cinder or oxidised scrap-iron may be used in lieu thereof.

512. The usual *charge of the Danks furnace* is about 650 lbs. of pig-iron introduced into the furnace at the chimney or flue end, and placed in from 30 to 60 per cent. of its weight of cinder left in the furnace after working off the previous charge; but it is recommended as being more economical in both time and fuel, to run the molten pig-metal either direct from the blast furnace, or to first melt the charge in the cupola, and run it from thence into the Danks furnace. As the charge melts down, the furnace is set slowly into motion, and with a charge of cold pig-iron the whole is melted down in about thirty minutes, the boil commencing in about ten minutes afterwards with grey iron, or in about three minutes with white iron, after complete fusion of the charge. During the boiling stage the revolving chamber makes from two to three revolutions per minute, the boiling at the same time being most vigorous, and the metal which is carried partially around as the chamber revolves, is constantly rolling back to the lowest point of the chamber, while some portions also adhere to the sides of the furnace and are carried farther around, such portions falling continually from the upper surface of the chamber into the bath of metal below; this rolling movement of the charges thus exposes more surface to the oxidising influences of the air and cinder. After about ten minutes' boil the metal begins to thicken, when the rotation of the furnace is stopped, the fire urged and the cinder perfectly liquefied, upon which, after tapping out the cinder, the rotation is resumed at the rate of from six to eight revolutions per minute, until the charge begins to collect and stick together, when the velocity is again reduced to about two revolutions per minute, and the

metal commences to ball up. During the process of balling up, the smaller detached masses collecting around the surface of the furnace are drawn by the puddler down towards the centre of the hearth, where the heavier ball falls upon them, and so collects them all into one ball weighing about 670 lbs., or a somewhat heavier mass than the total amount of pig-iron introduced into the furnace. The puddled ball is then withdrawn through the flue end of the furnace, and for this purpose the flue-piece is swung round in the manner already indicated, out of contact with the revolving chamber; while a forked lever worked by a crane is inserted into the furnace, when by a small movement of the chamber the ball is rolled over on to this lever, which is then withdrawn on to a bogie, which conveys the ball to a squeezer for the expulsion of cinder. Without further re-heating, the bloom at once passes from the squeezer to a three-high train of rolls, and is rolled into puddled bar which is sheared whilst hot into lengths suitable for piling; or if intended for boiler plates, instead of rolling the puddled bar direct as just described, it is first hammered out into a bloom about 7 inches square, which is then re-heated and rolled into a bar of $3\frac{1}{2}$ inches in width by 1 inch in thickness, and this is cut up and piled lengthwise and crosswise in alternate layers into a packet, which is re-heated and again hammered into a slab, to be in its turn again re-heated for rolling into a boiler plate.

513. The oxidation necessary for the puddling or conversion of pig into malleable iron in the Danks furnace, is almost wholly effected by the fettling or cinder introduced into the furnace; and the extra weight of puddled ball over that of the pig-iron charged, is derived by the reduction of iron during the fining stage of the process from the oxides of iron in the fettling of ore and scale.

514. But little cinder is formed in this furnace during the boiling stage, and from eight to ten charges can be worked off before the fettling requires repair. The

duration of the process varies between 1 hour and $1\frac{1}{2}$ hour according as white or grey iron is under treatment, and in America it is usual to work off about seven heats in the single turn of a day. The *consumption of fettling*, ore, scrap, forge-cinder, &c., is about 12 cwts. per ton of puddled bars produced, while the coal consumption reaches about 20 cwts. per ton of bars; there is thus no considerable direct economy in fuel over the fixed furnace, but there is a small economy arising from the greater number of heats (seven) worked off in the shift, against the five or six heats obtained from the ordinary furnace in the same time. It is claimed for the Danks furnace that it eliminates more completely the sulphur, silicon, and phosphorus than the regular puddling furnace, but it does not effect so perfect a working of the puddled ball, and the ball generally encloses within itself a considerable quantity of a thick cinder, which it is found difficult to expel completely from the shingled bloom.

515. At Pittsburg, and elsewhere in America where this process is largely carried out, heavier charges than those above mentioned are employed, as much as 900 lbs. being withdrawn from the furnace in a single ball, and special squeezers have been designed for the treatment of such large balls. The *Winslow squeezer* so employed consists of a pair of horizontal corrugated rolls (p. 306), above which is a cam making some fifteen or twenty revolutions per minute, and between which and the rolls the puddled ball is passed, and the cinder is thereby fairly expelled from the puddled ball, while the puddled bloom is left as a cylindrical mass with flattened ends ready for introduction into the puddling rolls.

516. In Spencer's revolving furnace, working at Hartlepool, the revolving chamber, unlike those previously described, is rhomboidal in form, and revolves upon axes or arms at either end, resting upon friction rollers; rotation being effected through gearing fixed to the end of the shafts or axes at each end of the revolving

chamber. In the inside of the chamber are longitudinal ribs for holding the lining and fettling in position, the lining itself consisting of blocks of *best-tap* from the re-heating furnaces, which blocks are built into the iron casing between the ribs just mentioned, and are then cemented together and coated over with a second layer of fresh-tap melted over their surface, the second layer being often introduced into the furnace in a molten state whilst the chamber is in rotation. The working of this furnace is in most respects similar to that of the Danks furnace last described, and, like it, is said to eliminate silicon and phosphorus from the charge more completely than the ordinary hand-puddling process.

517. The Siemens revolving gas furnace has been already described (p. 213).

518. The Crampton revolving puddling furnace is designed for the consumption of small coal, or coal slack, for which purpose the ground, sifted, and dried small coal, along with a blast of atmospheric air, is injected into the revolving furnace automatically, and in the proper proportions for complete combustion, so that the fuel is consumed without its coming into mechanical contact with the metal under treatment in the furnace, whilst the combustion under these conditions is attended with the production of a very high and regular temperature with very little smoke. The gas for combustion is produced and then consumed in the same revolving chamber, while the pig-iron for conversion is also treated in the same chamber.

519. The furnace consists of a revolving chamber rotated at a speed adjustable up to ten or fifteen revolutions per minute, either by a small horizontal or by a three-cylinder engine. It is also provided with a movable flue-piece, lined like the furnace itself with refractory materials, and into the end-plate of the flue-piece is fitted a trunk or tube-piece, bell-mouthed towards the flue, and through which a regulated stream of air and ground dry coal is injected into the furnace, several feathers or

partitions being arranged within the tube-piece to promote the better distribution of the fuel and air, and to prevent the coal-dust from falling on to the lower surface of the tube; while for the proper regulation of the supply of air and fuel to the requirements of the furnace at different periods the tube is fitted with adjustable doors, &c. The coal is first introduced into a tank or hopper, from which it is fed to the injection pipe and so to the furnace, by means of rollers which, with a suitably arranged lever and screw, place the rate of delivery under ready control. The flue-piece is kept in contact with the body of the furnace by rods and screws, except when removed for the withdrawal of the puddled ball. The several joints, as also the chamber itself, are kept cool by the circulation of water through a series of pipes and casings arranged for that purpose, whilst all the valves, levers, &c., necessary for controlling the supply of small coal, atmospheric air, as also the water to the water-jackets, come to the front and are under the ready control of the workman.

520. The furnace works with a *cinder-bottom*, for the preparation of which lumps of cinder are thrown into the bath of molten cinder remaining in the chamber after the withdrawal of the puddled balls of the previous charge. In this manner the cinder in contact with the cold lumps is chilled and sets or fixes around them, so connecting this fettling with the lining of the furnace in the manner already described when speaking of the Danks furnace, of which the bed is formed in a similar manner.

521. The method of procedure observed in the working of the furnace during the puddling process does not materially differ from that observed with the Danks furnace, and, as in it, the consumption of fettling per ton of pig-iron treated is also large, but the purification of the iron is reported to be more perfect, and where suitable coal is available the silicon from the ash of

the fuel increases the fluidity of the cinder, which is thus the more readily expelled from the puddled balls, and greater homogeneity in the puddled bars may be expected.

522. The **Pernot puddling furnace**,* instead of revolving in a vertical plane like those last described, consists of a revolving circular bed or hearth inclined at

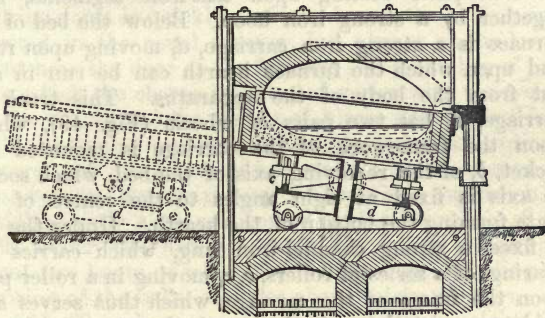

Fig. 49.—Longitudinal Cross-Sectional Elevation of the Pernot Revolving Puddling Furnace.

an angle of only 5° or 6° with the horizontal, in which plane it revolves, so that when the metal for conversion is in a fused condition it covers only a little more than the lower half of the bed; and the furnace as it revolves, therefore, exposes the fettling alternately to the oxidising action of the flame and to the reducing action of the molten metal, for whilst the fettling at the higher part of the hearth is exposed to the oxidising influence of the air, yet as the furnace revolves, this part in its turn passes beneath the fluid metal, and thus becomes the most active agent in promoting the desired changes of the puddling process. The conversion of the pig-iron is further promoted during the revolving of the bed by the adhesion of a thin layer of

* Herr Tunner, "Polytechnische Centralblatt."

the fluid metal over the surface of the bottom, thus exposing a greater surface of metal to the oxidising influence of the air passing through the furnace. But the turning-over and the balling-up of the charge both require to be done to a great extent by manual labour, or by mechanical arrangements exterior to the revolving bed. The bottom of the bed of the furnace consists of an iron plate resting upon cast-iron segments, held together by a strong iron hoop. Below the bed of the furnace is a strong iron carriage, *d*, moving upon rails, and upon which the furnace hearth can be run in and out from the body of the apparatus. This truck or carriage, *d*, has two pairs of wheels (Fig. 49), whilst upon the framework of the carriage is mounted the socket, *b*, of the revolving axis of the bed, which socket or axis is fixed at right angles to the centre of the plate forming the bottom of the hearth. Under the bed is fixed a strong channel-iron ring, which carries the bearings of a series of rollers, *c*, *c*, moving in a roller path upon the frame of the carriage, which thus serves as a guide to assist the central pivot in keeping the hearth central as it revolves. Rotation is imparted to the furnace by means of an endless screw or worm and a worm-wheel, the latter being fixed on the outer circumference of the ring which supports the roller bearings, whilst the former is driven either from a small engine direct or from a revolving shaft connected by a belt and pulley with the worm-shaft; in this manner a rotation at the rate of five or six revolutions per minute is given to the furnace.

523. With a new furnace the bed is prepared by introducing upon it iron ore and puddling-furnace cinder to the depth of about 2 inches, when the bed is run into the furnace as nearly as possible up to the iron plates supporting the brickwork at the bridges or blocks of the furnace, although the junction need not be perfect, an opening of an inch or more being quite permissible. The fettling is then melted, and the interstices filled

up with broken cinder, after which, the furnace hearth is set in motion at the rate of three or four revolutions per minute, so as to smooth over the surface of the fettling. The bed being thus prepared, the charge of from 15 to 20 cwts. of pig-iron is introduced, either cold or previously heated to redness in an auxiliary furnace, when the working proceeds much in the same manner as with the Danks furnace. The melting-down is quickly performed, and the balling-up is effected in the usual manner, but always at the lowest point near the door of the furnace. The number of balls into which the charge is collected varies with the weight of the charge and the weight of bloom desired, but from eight to twelve puddled balls constitutes an ordinary charge, and they are withdrawn to be hammered or squeezed in the usual way. The whole operation of puddling such a charge, including the shingling of the balls under the hammer or in the squeezer, occupies about two hours, of which the balling stage, including the drawing of the balls, occupies about thirty minutes.

524. The advocates of the Pernot furnace claim that it produces twice as much malleable iron with the same number of hands as is produced in the ordinary furnace, and with a corresponding economy; whilst the coal consumed per ton of puddled bars is some 20 per cent. less. It is much more easily repaired, since the roof is readily accessible when the hearth is run out, and it is less rapidly destroyed than the Danks furnace, while the loss of metal is reported to be about one-half only of that incurred in the ordinary puddling furnace.

CHAPTER XVI.

FORGE AND MILL MACHINERY, FURNACES, PLANT, AND OPERATIONS.

525. The term "forge" is applied in iron-works to the department of the works wherein is located, besides the puddling furnaces, the *shingling*, *blooming*, and *rolling machinery* employed in the production of puddled blooms, slabs, or rough bars from the spongy, granular, and imperfectly coherent masses of malleable iron and intermixed tap-cinder constituting the puddled ball. The *shingling* or *blooming* machinery for the consolidation and welding together of the particles of the puddled balls, and the expulsion of the cinder therefrom, consists of squeezers, helves, or hammers, and of the puddling rolls or forge-train, the last-mentioned comprising a train of two pairs of rolls, through which the shingled blooms from the squeezer, or from the hammer, are passed for conversion, without any re-heating, into slabs or puddled bars of about 3 inches in width and $\frac{3}{4}$ inch in thickness by some 16 feet in length, or into plates averaging from 6 to 15 inches in width, if intended for rolling subsequently into plates or sheets.

526. By the term "mill" is understood that department of the works in which the blooms, slabs, rough bars, &c., received from the forge, are cut up, piled, re-heated in re-heating or balling furnaces, again welded and finished by the mill-rolls into various classes of merchantable iron, such as merchant bars, rods, rails, plates, sheets, or other finished forms. But in the case of steel works, the operations of piling and re-welding are not carried on, the processes of the mill being confined to the rolling of steel ingots, either direct or after treatment under the hammer, and either with or without re-heating in the manner to be further mentioned hereafter.

527. The shingling and blooming machinery of the forge for the compression and consolidation of the spongy puddled ball received from the puddling furnace, with the expulsion of slag therefrom, consists of various types of squeezers, helves, and hammers. Of these the helves and hammers effect the desired changes by a series of blows or impacts of a falling weight upon the puddled ball, whereas the shingling by squeezers is effected by a direct compressive or squeezing force. This latter class of tool is less effective than hammers in the expulsion of cinder from the iron, and hence the bloom obtained from the squeezers is usually not so homogeneous, but contains more intermixed cinder than that worked under the hammer. The steam-hammer is thus the most effective, and it is hence being applied for shingling purposes in many of the newer works, to the exclusion of the older forms of helve and squeezer.

528. *Squeezers* are divisible into two classes according as their movement is *reciprocating*, as in the single and double-acting crocodile or alligator squeezers; or *rotary*, as in Brown's, Winslow's, and the other squeezers to be immediately described.

529. The single *alligator* or *crocodile* squeezer has two broad flat jaws, of which the lower one, forming the anvil of the machine, is fixed, whilst the upper one forms one end of a heavy cast-iron lever, either straight or cranked at its centre of oscillation. The upper jaw of the squeezer oscillates on a gudgeon or axis forming the fulcrum of the machine, while one extremity of the oscillating jaw is coupled by a connecting rod with a crank or its equivalent, driven either direct by a small engine or from some other rotating piece in the forge, as from the end of the engine shaft of the puddling rolls. In this manner the upper jaw, which is serrated with parallel angular teeth upon and across its under surface, so as to take a better hold of the puddled ball, opens and closes upon the lower fixed jaw. The shingler introduces the puddled ball hot from the puddling furnace into the

open end of the jaws farthest away from the fulcrum, and gradually moves the ball forward for still further consolidation by rolling it over towards the fulcrum of the crocodile after each stroke of the machine. At each stroke the bulk of the puddled ball is reduced by the escape of fluid cinder, which flows away from the mass over the sides of the lower jaw or anvil, and by the consolidation of the metal due to the pressure between the jaws of the squeezer. Finally the com-

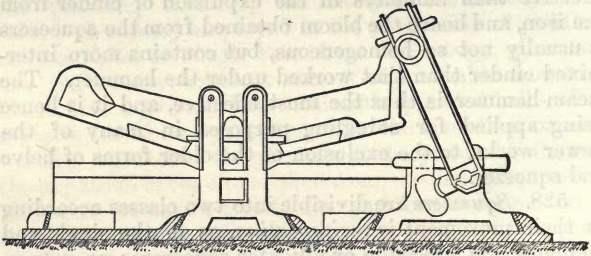

Fig. 50.—Front Elevation of Double-acting Crocodile Squeezer.

pressed ball is formed, by manipulating it between the jaws near the fulcrum of the machine, into a slab or bloom of about 5 inches in diameter and 18 inches in length. At the extreme outer end of the jaws the movement is sufficiently great to permit of the bloom being placed on end, and compressed endwise, so as to shorten or upset the bloom, and square up the ragged ends. The bloom, when finished at the crocodile, is still sufficiently hot for introduction into the puddling rolls for drawing down into puddled bars. The crocodile squeezer makes about 60 strokes per minute, and each ball receives about twenty or twenty-five compressions during its conversion into the puddled bloom.

530. *Double crocodile squeezers* only differ from the above in being arranged with a fixed and a movable jaw on either side of the fulcrum, as illustrated (Fig. 50), in which case the connecting rod is usually coupled to

one end of the movable jaw, which is somewhat prolonged for that purpose.

531. *Brown's squeezer* consists of a series of rolls supported in suitable housings or standards, with bearings which can be screwed up as required so as to regulate the distance between the rolls in the several pairs, and the pressure thus put upon the puddled ball as it passes between them. Each pair of rolls admits only of a smaller diameter passing between them than the pair immediately above, so that by increasing the number of rolls between which the ball passes, any degree of compression of the puddled ball can be secured. These squeezers are often arranged to give three compressions, in which case the puddled ball is introduced from the bogie to the top of the machine, and it passes downwards through each of the two lower pairs of rolls before falling from the bottom shoot of the machine on to a Jacob's ladder or other elevator, by which it is carried to the puddling rolls.

532. Modifications of the type of squeezer last described are in use in some of the Cleveland forges, consisting essentially of three rolls working in housings or standards after the manner of ordinary rolls, except that the two lower rolls are fixed side by side, and have a rotary motion only, whilst the third or upper roll, besides rotating, is capable of a vertical movement of about 12 inches. One of the lower rolls, *a* (Figs. 51, 52), has two collars, one near either end, turned upon it, and the roll, *b*, has corresponding grooves turned upon it, the distance between these collars thus regulating the length of the bloom as it leaves the squeezer, whilst the top roll, *c*, can be set down by screws in the housings, and its final position fixes the diameter of the bloom. The upper roll, *c*, is slightly over-balanced, so as to keep it constantly in contact with its bearing beneath the setting-down screws, *d, d*, that are used in setting the roll up and down as the dimensions of the puddled ball become reduced by its consolidation between the three rolls; these

setting-down screws being moved by worm and worm-wheel gearing driven from the engine. The puddled ball

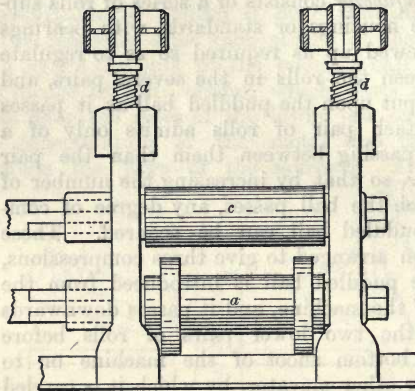

Fig. 51.—Front Elevation of Squeezer for Puddled Balls.

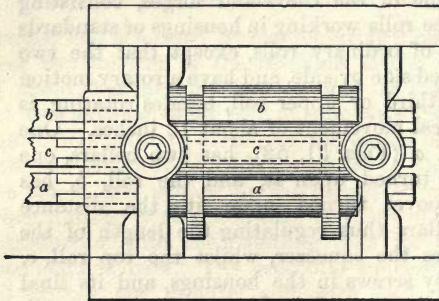

Fig. 52.—Plan of Squeezer for Puddled Balls.

to be squeezed is tipped upon the lower rolls from the bogie upon which it is brought from the furnace, and the top roll is then gradually brought down upon it, whereby the ball is subjected to pressure between the three rolls, till it assumes the form of a round bloom having the desired diameter and the necessary consolidation, when by raising the top roll the bloom is thrown out from the squeezer, with a little assistance from the workman aided by a bar. The bloom is again received on a bogie for conveyance to the forge rolls, into which it is at once introduced for rolling into puddled bar.

The puddled ball is tipped upon the lower rolls from the bogie upon which it is brought from the furnace, and the top roll is then gradually brought down upon it, whereby the ball is subjected to pressure between the three rolls, till it assumes the form of a round bloom having the desired diameter and the necessary consolidation, when by raising the top roll the bloom is thrown out from the squeezer, with a little assistance from the workman aided by a bar. The bloom is again received on a bogie for conveyance to the forge rolls, into which it is at once introduced for rolling into puddled bar.

533. *Rotary squeezers* may be arranged either horizontally or vertically, and they consist of a strong fixed cast-iron casing forming about three-fourths of a complete cylinder, with about one-fourth of the circumference removed to admit of the introduction of the puddled ball into the machine. The inner surface of this cylinder is roughened by corrugations, or is studded with blunt triangular studs or teeth, while within the outer cylinder another cylinder or drum revolves upon an axis parallel with the axis of the outer fixed casing, but eccentric with regard to it. The outer surface of this inner revolving drum is roughened similarly to the inside of the casing, so that as the inner cylinder revolves the puddled ball is carried around between the roughened surfaces of the inner drum and the outer casing, the space between the two surfaces diminishing in the direction of the rotation from the point of entrance of the puddled ball to its ejection. Owing to the eccentricity of the inner barrel with respect to the casing, the puddled balls introduced at the widest part are carried round by the revolution of the inner drum and forced through the smaller part of the apparatus, whereby the particles of the puddled ball undergo a gradual welding together; and finally the ball falls from the narrower end of the machine as a cylindrical bloom ready for passing through the puddling rolls. The inner drum rotates at a velocity of about twelve revolutions per minute, and is driven through a bevel wheel and pinion placed beneath the machine, and connected respectively with a driving shaft from some convenient source of power and the axis of the drum. But since the distance between the revolving drum and the casing at any point is always fixed, it follows that the puddled balls to be shingled or squeezed in this machine should be fairly regular as to size and weight, since the larger the ball the greater will be the compression to which it will be subjected in passing through this machine, so that the shingled blooms will not be uniformly

homogeneous if they are produced from different-sized puddled balls, besides which undue strains are put upon the machine if very large balls be passed through it.

534. A special squeezer designed by Winslow and improved by Danks has been introduced for working the large balls produced in the Danks furnace. The squeezer, of which the end elevation is shown in Fig. 53, consists of

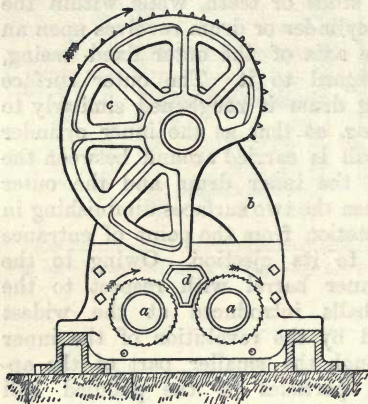

Fig. 53.—End Elevation of the Danks-Winslow Squeezer.

two corrugated rolls, *a, a*, of about 18 inches in diameter and 4 feet in length, the necks of which revolve in bearings fixed in strong cast-iron housings or standards, *b*, whilst above the rolls, on a shaft parallel with them, is fixed a large, irregular, or cam-shaped roll, *c*. The shaft of this roll is connected with each of the two lower rolls by gearing, through which the whole is

driven ; so that the puddled ball which is introduced into the machine at the widest or most open part of the cam, and carried downwards by its rotation and by that of the corrugated rolls, is compressed and reduced in diameter as the cam revolves, two revolutions of the cam sufficing to squeeze the ball into a bloom ready for the puddling rolls. The rolls, *a, a*, revolve at the rate of from fifteen to twenty revolutions per minute, and in the same direction as the cam, *c*. At the end of the rolls, *a, a*, are fixed rams or hammers working horizontally, the end of whose tups are formed as shown at *d*, of a shape that will permit of their passing

into the space above the rolls, and between them and the cam, so that whilst the ball is undergoing pressure between the rolls with reduction in its diameter, the ends are prevented from spreading out unduly by a few strokes of these horizontal hammers.

535. An *hydraulic squeezer*, a modification of the above, is also in use in America ; it consists of two horizontal lower rolls and a large irregularly-shaped upper roll, and between the upper and the lower rolls the puddled ball is squeezed. The bloom is thrown in and out from these rollers by hydraulic cylinders placed below.

536. Hammers of various classes are largely employed in the forge both for shingling the puddled ball, and for the working of the finished iron, or of steel ingots into the various classes of blooms, billets, forgings, &c., required for the rolling mills and by the engineer. For shingling purposes the hammer, with its percussive blow, expels the slag or cinder from the puddled ball better than the compressive action of the various squeezers. In the older forges the *tilt* and *helve* hammers are still to be found, although in modern forges the steam hammer is more generally employed, even for shingling purposes.

537. The *tilt hammer* is not commonly used for shingling purposes, being small, not generally exceeding 5 cwt. in weight, and it works at a higher speed than is desirable when shingling is being performed ; but it is still employed, especially in some parts of Sweden, in connection with the charcoal fineries, for drawing down shingled or other blooms into bars or other finished work. The tilt hammer consists of a lever or arm, formed of a single beam, or of two beams bolted together, of straight-grained timber hooped around by wrought-iron rings ; at one end of the arm is fixed the head, having the form of a heavy sledge hammer, whilst the cam which works the hammer, operates at the opposite or tail end of the lever, the fulcrum being formed by the two arms of a trunnion ring resting on a vertical timber framework placed between the hammer head and the

cam, but nearer to the latter than to the former ; so that as the cam, which is a revolving wheel with twelve or fourteen projecting teeth or *wipes*, revolves, the wipes press down the short end of the lever, and so raise the hammer head until the lever is so far depressed that the wipe on the cam slips from the end of the lever, when the hammer then descends by its own weight, and falls upon the work on the anvil. The force and rapidity of the fall are further increased by the introduction of an elastic piece of timber or spring board beneath the short

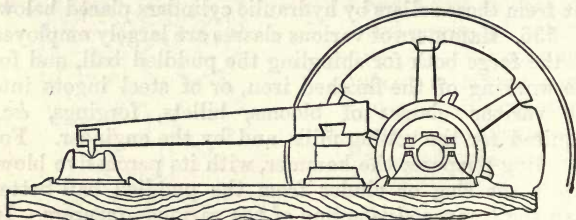

Fig. 54.—Front Elevation of the Nose or Frontal Helve.

arm. As the cam revolves and the next tooth comes around, it repeats the same operation, and the strokes of the hammer thus follow in quick and regular succession. The end of the lever is shod with iron at the point where the wipes bear, so as to prevent undue wear at this part. The bottom anvil of the tilt hammer is of wrought-iron fitted into a heavier mass of cast-iron.

538. Helve or lifting hammers are of two types, and are made from 30 cwt. to 10 tons in weight ; they are still used for shingling in forges where the steam hammer has not yet been introduced. In one class of helve the cam acts upon the lever at one extremity, whilst the fulcrum is placed at the other extremity, constituting the *Nose* or *Frontal helve*, as illustrated in Fig. 54. In the *Belly helve* the cam is placed below the surface of the ground, and acts upon the arm or lever at a point between its head and the fulcrum.

539. In the nose or frontal helve (Fig. 54) the teeth of the revolving cam act upon a projection immediately in front of the hammer head, the arm of the helve being a heavy mass of cast-iron supported at one extremity upon a pivot or trunnion, working in open bearings. In this manner the arm or lever is lifted up as the cam revolves, and is then allowed to fall by its own weight upon the puddled ball placed on the anvil beneath. Into the head of the arm the working or hammer face of wrought-iron is dovetailed, and keyed so as to permit of ready removal for the renewal of the faces, as is frequently required. Such helves as are still in use in Staffordshire, &c., for shingling purposes are from 5 to 6 tons in weight, and the cam, which is about 5 feet in diameter, and fixed upon a continuation of the fly-wheel shaft, has five teeth or wipes, so that the helve makes five strokes for each revolution of the cam, in which manner the helve makes from 80 to 100 strokes per minute, and the maximum lift of the head is from 16 to 20 inches.

540. In shingling with these helves the ball from the puddling furnace is placed by the assistant upon the anvil of the helve, which is kept clear and free during the time that it is not at work, by supporting the head of the helve upon a wooden support or stop so as to just clear the wipes on the revolving cam, as the latter continues its revolutions. It is carefully observed that the head is never allowed to fall upon the clean anvil, since repeated blows from this great weight upon the hard resisting iron anvil might be attended with damage to it. Now, when the puddled ball has been placed on the anvil, the helve head is lifted by placing a piece of iron upon the upper surface of a wipe or tooth of the cam, so as to make it catch the nose of the helve earlier and so lift it slightly higher than usual, thus permitting of the prop being withdrawn, when the head falls upon the puddled ball on the anvil as the wipe leaves the nose of the helve. The blows are repeated by the succeeding

wipe of the cam first lifting the head and then allowing it to fall as the cam rotates, and thus a succession of blows is delivered. After having received from fifteen to twenty blows, between each of which the shingler turns over the white-hot mass, presenting fresh surfaces to the action of the blow, the puddled ball will have been formed into a flattened bloom, ready for introduction into the puddle rolls.

541. The **Belly helve**, owing to the cam being generally fixed beneath the floor level, and acting also between the head and the fulcrum of the machine, gives a greater space around the anvil for the manipulation of the puddled ball than the helve last described.

542. The **steam hammer** is now generally preferred to the helve for shingling purposes, since its blow can be regulated according to the work to be done; as, for example, when the puddled ball at a welding heat is first placed upon the anvil, a series of light short blows in quick succession is desirable until the ball has become more coherent and consolidated, after which heavier blows are required. Such an adjustment of the blow is possible with the steam hammer by throttling the escape of steam to the exhaust, whereby a cushion of steam is preserved beneath the piston of the hammer as it descends upon the work, thereby diminishing its velocity and the weight of its blow; but with the helve the head is always lifted to the same height, and such control as this is impossible. Moreover, the heavy blows of the steam hammer consolidate the metal more quickly and expel the cinder more effectually than the helve, since the expulsion is effected by the hammer whilst the metal and cinder are still at a high temperature, and so permitting of a readier escape of the fluid cinder than is afforded as the metal and cinder cool.

543. Steam hammers are somewhat differently constructed according to the special work to which they are to be applied. Thus the smaller hammers adapted to the

forging and drawing down of bars, and used instead of the tilt hammer already described, generally consist of a single cast-iron standard, in front of which the piston and hammer head descend on to the anvil. Supported upon the top of the standard is a vertical steam cylinder of which the piston rod passes through a gland or stuffing box in the lower cover of the cylinder, and is attached to a heavy block or tup which thus ascends and descends with the piston, as the steam is admitted to or escapes from the cylinder the rotation of the piston and tup being prevented either by planing a flat-side upon the piston rod and making the stuffing box of a corresponding shape, or otherwise the tup is made to work in a guide on the face of the hammer standard. The cylinder is provided with suitable valves connected with levers, by small movements of which the workman can control readily both the ascent and descent of the hammer tup. These smaller hammers, as also the larger ones, are made so that the hammer tup and its connections of piston and piston rod are lifted by the admission of steam beneath the piston, and then allowed to descend upon the work by opening the valve, and so allowing the steam from beneath the piston to escape freely to the atmosphere; or, as affording a much more effective hammer, it is now a more general practice especially for the heavier forging hammers, to admit steam upon the top of the piston during its descent, as well as exhausting the steam from the under side of the piston, thus obtaining the heavier blow corresponding to the increased acceleration due to the pressure of steam on the piston beyond that due to the falling of the tup and piston rod through the length of the stroke.

544. In the larger hammers of 30 cwt. and upwards the single standard of the hammer is replaced by two standards, between which the tup ascends and descends. For shingling purposes, hammers in which the aggregate weight of the falling mass of tup, rod, and piston is from 2 to 5 tons, are in most frequent use, whilst for forging purposes

and especially in the treatment of large masses of steel, hammers of 10, 20, 50, and 100 tons are at work. Figs. 55 and 56 are illustrations of a $4\frac{1}{2}$ -ton shingling hammer with cast-iron standards, supplied by Messrs. Thwaites and Carbott to a South Wales forge. It is double-acting, and has a cylinder, *a*, supported upon cast-iron standards.

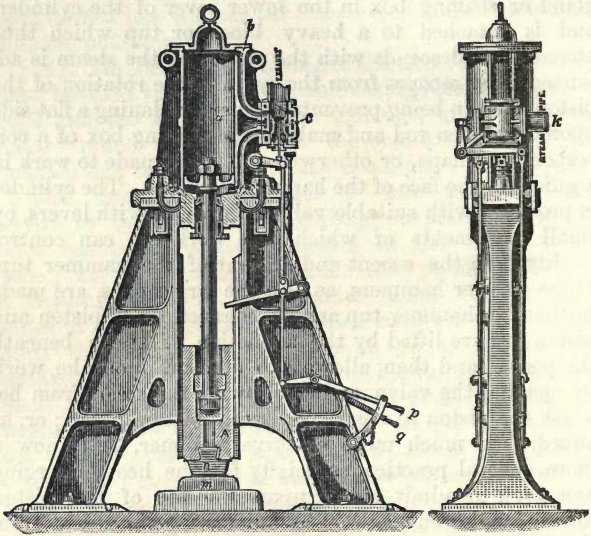

Fig. 55.—Front Elevation of Double-Acting Steam Hammer, for Shingling of Puddled Balls and Cogging of Steel Ingots, showing the Steam Cylinder, Valves, and Hammer tup in section.

Fig. 56.—Side Elevation of Steam Hammer.

Fig. 55 shows the steam-ports, *b*, *b*, with the cylindrical equilibrium valve, *c*. The extremity of the valve casing is connected with a pipe opening above the roof of the building for the escape of the exhaust steam into the atmosphere. Thus the steam escapes from the bottom ports, and exhausts through the inside of the cylindrical valve, *c*, whilst from the upper port the steam escapes

directly to the atmosphere as the valve descends for the admission of steam, which enters by the pipe, *k* (Fig. 56), and circulating in the space around the valve, is admitted alternately above and below the piston as the valve descends or ascends. The valve, *c*, is easily worked by

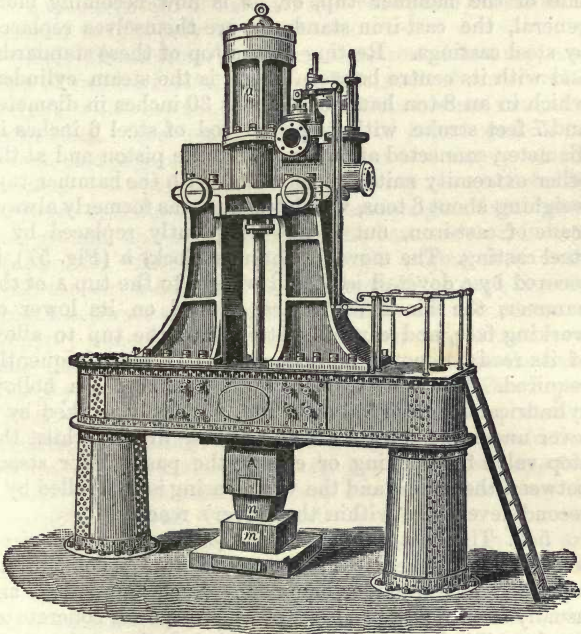

Fig. 57.—Double acting Steam Hammer for general forging purposes.

the lever *p*, whilst the stop-valve between the boilers and the hammer is regulated by the lever *q*.

545. In steel works a type largely adopted for hammering steel ingots into slabs, blooms, billets, and general forgings, &c., is a double-acting hammer of 8 tons or upwards, with wrought-iron square or circular columns

(Fig. 57) supporting a deep cross-girder of box section, also formed of wrought-iron plates and angle irons riveted together; upon this girder is carried a pair of standards of cast-iron fitted upon their inner faces with steel guides working in a corresponding groove in each side of the hammer tup, or, as is now becoming more general, the cast-iron standards are themselves replaced by steel castings. Resting on the top of these standards, and with its centre between them, is the steam cylinder, which in an 8-ton hammer is about 30 inches in diameter and 7 feet stroke, with its piston rod of steel 6 inches in diameter, connected at one end with the piston and at the other extremity suitably connected with the hammer tup, weighing about 8 tons, which tup also was formerly always made of cast-iron, but is now frequently replaced by a steel casting. The movable hammer block, *n* (Fig. 57), is secured by a dovetail joint and wedges to the tup *A* of the hammer, the block being first planed on its lower or working face, and carefully fitted into the tup to allow of its ready removal and change, as is very frequently required. The slide valve of these hammers is a hollow cylindrical-balanced valve, *c*, Fig. 55, easily worked by a lever under the control of the hammer driver, whilst the stop valve for opening or closing the passage for steam between the boilers and the valve casing is controlled by a second lever, also within the driver's reach.

546. The *foundations for steam-hammers* are required to be of the best, heaviest, and most substantial description, especially for the larger hammers. Such foundations are usually formed first of a layer of concrete, or of concrete on wooden piles driven as far as possible into the earth; upon the concrete are placed cast-iron bed-plates of weights proportionate to the size of the hammer; or, in heavy hammers, it is usual to alternate heavy cast-iron plates with balks of oak timber arranged in various ways, and upon this foundation are finally fixed the heavy anvil-block or blocks, of cast-iron, into which the working bottom anvil block, *m* (Fig. 55), is fitted by a dovetail joint

and wedges in the same manner as the top anvil or block is fixed in the tup of the hammer. As indicating the massive character of steam-hammer foundations, it will suffice to note that the bottom anvil block for a 10-ton double-acting hammer weighs about 110 tons, whilst the superstructure of hammer and base plate of the same hammer weighs only about 80 tons.

547. *Ramsbottom's duplex* or horizontal hammer consists of two horizontal blocks or tups, each of considerable weight, which are supported upon friction wheels running upon rails. The horizontal blocks or tups approach towards, and separate from, each other alternately as the hammer is worked, for which purpose they are connected by a system of links with a vertical steam-engine fixed below the ground, and so underneath the hammer; or, instead of the link connections and a single engine, it is usual with the larger hammers to work each of the tups directly from a separate steam-engine, in which case it is necessary to apply a mechanical arrangement, whereby it is ensured that the two sliding tups approach the work at the same velocity, and strike it at the same time. The duplex hammer is without anvil, the work being supported on a carrier or carriage between the tups, which should thus strike the work simultaneously upon its two opposite sides. This hammer has not, however, been very favourably received, nor generally adopted.

548. For the production of forgings, &c., in iron and steel, by compression instead of by impact from the blows of the steam hammer, more elaborate and refined tools have been introduced, in which hydraulic power has been largely brought into service. Of such machines are the powerful hydraulic forging presses of Sir Joseph Whitworth and Co., and the smaller presses of Mr. Haswell, of Vienna, while particular modifications of such plant occur in the various special presses employed for flanging and bending plates now in extensive use for the finishing of boiler and ship's plates for the engineer.

549. The Haswell press is not capable of the general

application to which the Whitworth presses are applied, its operations being confined to specific purposes, such as the forging of wheels, axle boxes, flanging, &c., where special dies are employed for the work. The hydraulic or pressing ram in this press is placed vertically, and acts downwards upon the work placed on a lower table or anvil, and so alters the form and dimensions of the forging by the continued application, or by the repetition of a pressure exerted by the hydraulic ram descending upon the work from above; whilst in stamping or pressing wheels, and such objects as are formed in stamps or dies, then one set of dies is carried upon the lower anvil, whilst the upper or top dies are carried by the vertical ram. The work to be pressed into shape is heated to a suitable temperature, and placed upon the lower dies, when the hydraulic ram descends carrying with it the top dies, and the metal is so pressed into the spaces between the two dies, giving to it the form designed by the dies, and corresponding to the object to be produced. To give a quick return movement to the upper or pressing ram, it is connected by means of a cross-head and descending suspension rods, with the ram of another *smaller* hydraulic cylinder carried above the machine, and which is kept during the working of the press in constant communication with a small hydraulic accumulator or source of constant water pressure; thus as the greater pressure corresponding to the larger area of the forging ram is removed, by closing the valve from the pumps, and opening the passage to the exhaust as the forging stroke is completed, then the ram of the smaller cylinder immediately lifts the forging ram from the work, and so leaves it ready for the succeeding stroke, so that the strokes of the press can be made in rapid succession.

550. The forging press of Sir J. Whitworth and Co. is employed more particularly in the forging of large masses of steel, such as shafting, hoops for ordnance, &c., for which purpose these presses have been made capable of exerting a compressive force of upwards

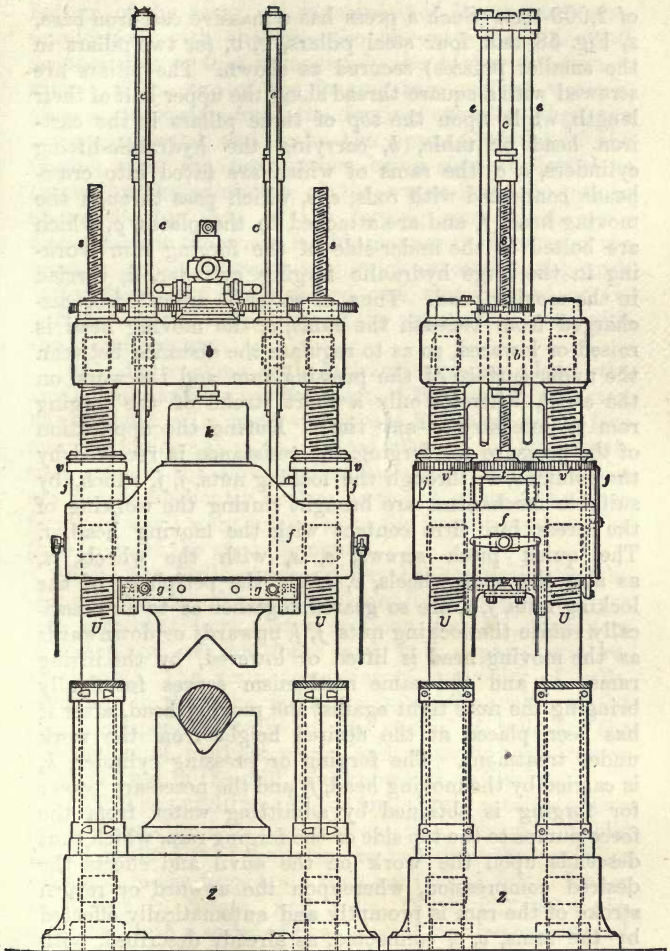

Fig. 58.—Front and End Elevation of Sir J. Whitworth and Co.'s Hydraulic Forging Press.

of 2,000 tons. Such a press has a massive cast-iron base, *z*, Fig. 58, and four steel pillars, *u*, *u*, (or two pillars in the smaller presses) secured as shown. The pillars are screwed with a square thread along the upper half of their length, while upon the top of these pillars is the cast-iron head or table, *b*, carrying the hydraulic-lifting cylinders, *c*, *c*, the rams of which are fitted into cross-heads connected with rods, *e*, *e*, which pass through the moving head, *f*, and are attached to the plates, *g*, which are bolted to the under-side of the forging ram working in the large hydraulic forging cylinder, *k*, carried in the moving head. Thus, as water is admitted or discharged from beneath the rams, *c*, the moving head is raised or lowered, so as to regulate the distance between the under-surface of the pressing ram and the work on the anvil, whereby only a short stroke of the forging ram is necessary at any time. During the application of the pressure for forging, the resistance is received by the columns, *u*, through the locking nuts, *j*, *j*, which, by suitable mechanism are brought during the working of the press into firm contact with the moving head, *f*. The quick pitch screws, *s*, *s*, with the wheels, *t*, as also the spur wheels, *v*, *v*, on the periphery of the locking nuts, *j*, *j*, are so geared together as to automatically rotate the locking nuts, *j*, *j*, upwards or downwards as the moving head is lifted or lowered, by the lifting rams, *e*; and the same mechanism serves for finally bringing the nuts tight against the moving head, after it has been placed at the desired height from the work under treatment. The forging or pressing cylinder, *k*, is carried by the moving head, *f*, and the necessary power for forging is obtained by admitting water from the force-pumps to the top side of the forging ram, which thus descends upon the work on the anvil and effects the desired compression, whereupon the upward or return stroke of the ram is promptly and automatically effected by the rams, *c*, *c*, connected, as already described, with the plates, *g*. During the working of the press, the

bottom of the rams, *c c*, is maintained in constant communication with the pressure of water from a small accumulator, so that immediately the higher pressure is taken off the top of the forging ram and the water is allowed to escape from the forging cylinder, then the rams, *c, c*, ascend, and make the upward stroke of the forging ram, the next stroke being simply effected as before, by the admission of the water from the pumps on to the top side of the forging ram which again descends upon the work. In this manner the strokes of the press follow in comparatively quick succession, the work under treatment being moved and manipulated as required, between the strokes of the press, exactly as with the steam hammer.

551. In working with hydraulic forging plant, the anvils and movable bottom faces of the forging ram may be either flat, as is usual with steam hammers, or the face may be modified so as to be more effective in their operation, since in the slow application of pressure the anvils are not so frequently broken as would occur if the same forms of anvil were subjected to the impact produced by the stroke of the steam hammer.

552. The **Rolls** employed for the conversion of the shingled bloom of malleable iron into puddled bar, or into merchant bars, plates, sections, &c., &c., form part of the plant of the forge and mill departments respectively. The train consisting of two pairs of rolls, occurring in the forge, is known as *puddling rolls*; whilst the corresponding train of two stands of rolls for the production of sections, plates, and other finished iron or steel, is fixed in the mill, and known as *mill rolls*.

553. The **puddling rolls** or **forge-train** consists of two pairs of cast-iron rolls placed in one line. The pair of rolls placed at the left of the train are known as the *roughing rolls*, and in the forge-train they are from 3 feet 6 inches to 5 feet in length, and from 18 to 22 inches in diameter, with a series of oval, Gothic, or diamond-shaped grooves turned upon their surface, which grooves are

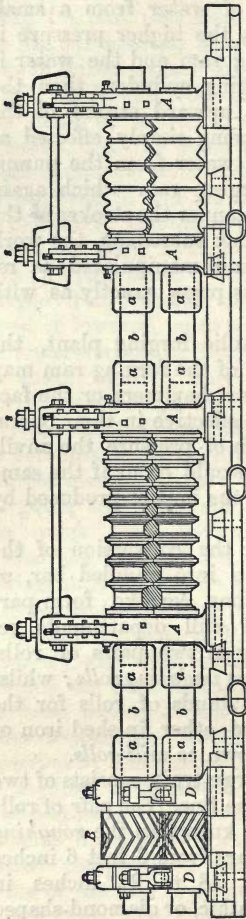

Fig. 59.—Front Elevation of Mill Rolls for Rolling Sections, Rails, &c.

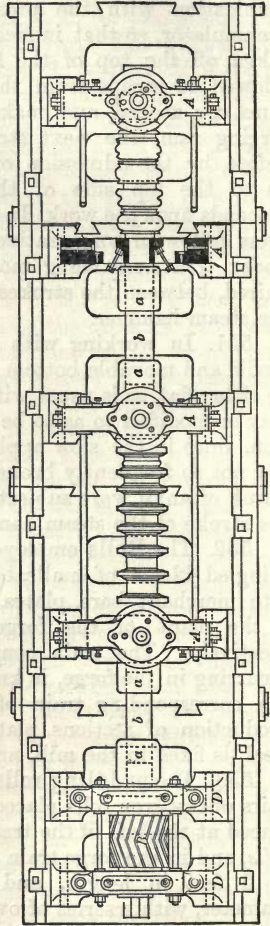

Fig. 60.—Plan of Mill Rolls with one Standard in Section.

roughened by cutting indentations upon their surface with a chisel, so that they may the better take hold of the shingled bloom when it first enters between the rolls. The first two or three grooves of the roughing rolls are Gothic-shaped, whilst the others are diamond-shaped, and the depth of the grooves also diminishes from left to right along the rolls. The two rolls of each pair are placed one above the other, in the same manner as the mill rolls (Fig.

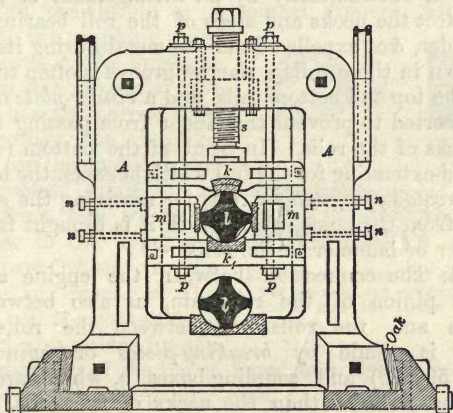

Fig. 61.—End Elevation of Roll Housing, or Standard for the Mill Rolls.

59), and the necks or bearings of the rolls are supported upon brasses, in massive cast-iron *housings* or standards, A, A, (Figs. 59, 61). The lower roll runs in a line with the driving-shaft of the engine; whilst between the engine and the mill is a pair of spur or helical toothed pinions, B, B (Fig. 59), of the same diameter as the rolls, which pinions run in their own standards or housings, D, D. The outer end of the lower pinion is connected direct with the engine shaft, whilst the other end is coupled to the bottom roll by connecting *spindles*, b, b, and *coupling-boxes*, a, a, as illustrated in Figs. 59 and 62. The upper pinion is coupled in the

same manner with the top roll, and is driven by the lower pinion; so that the rolls like the pinions thus revolve in opposite directions. The distance between the rolls is adjusted by screws, *s*, *s*, passing through nuts in the top of the housings, the lower extremity of the screws acting upon the top bearers, *k* (Fig. 61), on the necks of the rolls, and the screws are worked down either by hand, through levers upon the heads of the screws, or fed down automatically by an arrangement of gearing. To protect the necks and steps of the roll bearings from the cinder, &c., expelled from the metal during its roughing-down in these rolls, a narrow groove is often turned in both the top and bottom rolls, and a *cinder-plate* of sheet-iron inserted to prevent the cinder from passing towards the necks of the rolls. In front of the bottom roughing roll and extending for the full width between the housings is a serrated *fore-plate* or rest, for receiving the shingled bloom from the bogie, upon which it is brought from the squeezer or hammer to the rolls.

554. The connection between the engine and the bottom pinion of the roll-train, as also between the pinions and the rolls and between the rolls themselves, is made by *breaking-pieces* or *spindles*, *b*, (Figs. 59, 62) and coupling-boxes, *a*, which are made somewhat weaker than the necks of the rolls, so that whenever the mill encounters any unusual resistance or sudden strain these spindles break before any serious damage can be done to the forge-train. The necks of the rolls project beyond the bearings in the housings, and have the same form as the end of the spindle, *b*, whilst the coupling-boxes or *wabblers*, *a* (Fig. 62), fit easily upon the projecting end of the roll, as also upon the end of the spindle. When the spindle with its two coupling-boxes has been placed between the two rolls or other necks to be coupled, the coupling-boxes already placed upon the spindle are moved half their length over the wabblers end of the roll or pinion, as the case may be, so as to connect the two; whilst the slipping back of the boxes during

the working of the mill is prevented by the introduction of wooden or iron stops, laid in the hollow of the spindles and between the ends of the coupling-boxes; the stops are secured in position and prevented from falling out during the revolution of the rolls by twisting an iron wire or band around them and the spindle.

555. The *finishing rolls* of the forge-train are similar in their housings to the roughing rolls just described, but instead of the Gothic or Λ -shaped grooves, which are turned in the roughing rolls, the grooves in the finishing rolls are flat channels, and form, when the pair of rolls are together, the required section for the puddled bar. The grooves diminish in depth from left to right, and those in the upper roll stand over those in the lower. In front of the bottom roll is a *fore-plate* or rest, and also guides for the easier insertion of the bloom from the roughing rolls into the grooves of the finishing rolls.

556. The puddle rolls receive the puddled blooms whilst they are still hot from the squeezer or hammer, and the metal of the shingled bloom is thus further consolidated—by first introducing it into the largest groove at the extreme left of the roughing rolls. After passing through them the bloom is returned over the top of the rolls, to be again inserted from the front side into the next groove to the right, and so on in succession through the several grooves of the roughing rolls as required to produce the desired bloom. The bloom so obtained is passed onwards to the finishing rolls of the train, where it is passed in like manner successively through the several grooves or *holes* of this pair, until long flat bars with more or less ragged

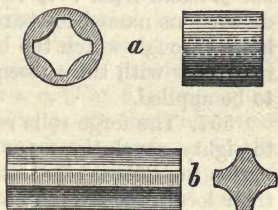

Fig. 62.—Coupling Box and Breaking Spindle for connecting the Rolls, and the Rolls with the Pinions, &c.

edges and a rough surface, and of from 3 to 7 inches in width, and from $\frac{3}{4}$ inch to $1\frac{1}{2}$ inch in thickness, according to requirements, constituting "puddled bar," or "No. 1 iron," are produced; from this No. 2 iron is prepared, as already described (p. 209), by the cutting up and piling of No. 1, reheating it to a welding heat and again passing it through the rolls. If the puddled bars are intended for cutting up and piling into piles for the production of plates, then the width of the puddled bar is made from 7 to 15 inches, instead of the smaller dimensions named for bars, &c., and thus the grooves or holes through which the bloom is passed in the finishing rolls vary with the subsequent use to which the iron is to be applied.

557. The forge rolls revolve at the rate of from fifty to eighty revolutions per minute, but the speed adopted varies in different localities according to the nature of their local productions; and thus the quicker speeds are more general in Wales, whilst the slower speeds are more prevalent in Staffordshire and the Midlands. The rolls, as also their necks or bearings, are kept cool by running a continuous but regulated supply of water over them.

558. The mill rolls are employed for the production of finished iron from the puddled bar, for which purpose it is cropped or cut up in suitable shears, and piled in various ways, for the production of a parcel or packet, which is then inserted into a balling or reheating furnace for raising it to a welding heat, and after which it is passed through the mill rolls to weld together the constituent bars of the pile producing thereby No. 2 and higher grades of merchant iron, rods, bars, sections, &c., the quality depending upon the number of times the bars have been cut up, piled, reheated, and rewelded. The *piles* employed in the production of the heavier sections of merchant iron, rails, &c., vary in size from 4 feet 6 inches long and 12 inches square to 18 inches long and three inches square, but the latter are exceptional, such light sections being rolled from "*billets*," which are

merely short lengths of square bars of a section and weight required to produce the finished product.

559. The *mill rolls* or *mill train* (Figs. 59, 60), for rolling merchant iron, like the forge train, consists of two sets of rolls, of which the *roughing* or *billeting rolls* average about 6 feet 6 inches in length and 22 inches in diameter, whilst the *finishing* rolls are somewhat smaller in diameter and shorter in length; but their length and diameter vary considerably in different Works, being much influenced by local or other special requirements. The rolls run in bearings carried in housings as described for the puddle rolls, except that the finishing rolls in the mill are also provided with tightening and adjusting screws *n, n*, (Fig. 61) for keeping them more accurately in position as the bearings wear down; in addition to the setting down screws, *s*, in the head of the housings for adjusting the distance apart of the rolls. The necks, *l*, of the rolls do not rest in continuous brass bearings, but bear upon four small brasses carried respectively in the bearers or *riders, k, k*, and the side-chocks, *m, m*, as shown (Fig. 61), the side brasses being capable of adjustment by the set screws, *n, n*. The top roll is carried by a bolster, *k*, supported at each end from the top of the standard by the two bolts, *p, p*, which pass through the rider, *k*, and the side chocks, *m*; or in other cases, instead of passing through the top of the housing, the bolts *p, p*, are on the outside of the housings and suspend the bearer, *k*, from two lugs cast for this purpose on the side of the standards. The power of the engine is transmitted through a claw-clutch or crab on the end of the engine shaft, and thence through a spindle to the lower pinion of a pair which run in their own standards, while the wabblers ends, *a, a*, of the pinions (Fig. 59) are connected by spindles and coupling-boxes or *wabblers* with the ends of the roughing rolls; the other projecting or wabblers ends of the two roughing rolls being in like manner coupled by boxes and spindles with the near ends of the two finishing rolls; or, as is sometimes

done, only the lower finishing roll is connected by a spindle with the lower roughing roll, and motion is then imparted to the top finishing roll by gearing fixed on the outer projecting ends of the two finishing rolls. This latter method of driving from the lower roughing roll only has the advantage of permitting the use of larger or smaller roughing rolls, as may be desired, without interfering with the finishing rolls.

560. In rolling small and light sections, which are therefore whilst hot very flexible and difficult to keep from bending and twisting during the operation, it is usual to provide an apron or *fore-plate* in front of the rolls, as also *guide jaws* for directing the work straight as it enters the rolls, in which manner much of the twisting is avoided, and the train so provided is hence known as a "*guide train*," and the iron produced therein as "*guide iron*."

561. In rolling sections, bars, &c., the bottom roll is always provided with "*stripping-plates*;" these are plates of iron which rest at one end in a cross bar supported by the roll standard, and at the other end upon the roll itself. They are shaped to fit into the several grooves of the rolls, and are also bevelled off at their lower edge so as to fit on the circumference of the roll, with their upper surface tangential to the surface of the roll. They thus act as chisels or wedges in clearing the bars from the grooves of the bottom roll, thus preventing "collaring," or wrapping of the bars around the bottom roll.

562. In two high trains revolving constantly in one and the same direction it is, as already explained, necessary to return the work over the top roll from the back to the front of the rolls, after each pass of the work between the rolls; and thus much time and labour is lost, to overcome which either "three high rolls" or mills that can be reversed at each passage of the work have been largely adopted for the mill-trains.

563. In the case of reversing mills the reversal is effected either by reversing the engine itself, as

introduced by Mr. Ramsbottom for the rolling of rails, &c., or by the introduction of hydraulic, friction, or other clutches and gearing on the engine shaft, whereby the rotation of the rolls is reversed whilst the engine continues its revolutions always in the same direction.

564. For lifting the work to the top of the upper roll in the two high non-reversing mills, it is usually sufficient when light work is being rolled to receive it as it issues behind the rolls upon forked levers suspended from a travelling carriage above, and by which the workman raises the bar to the required level, so that the roller-man in front of the rolls may seize it with his tongs and draw it forward on to the fore-plate of the mill for insertion into the next hole of the rolls; but where heavy sections or plates are rolled, some two high plate mills have movable fore-plates or feed-plates fitted to the mill, so that as the work issues from behind the rolls it is received on this plate, which is at once raised to the required level by a single-acting engine, or by an arrangement of levers worked either by hand or by power, or the table is elevated by an hydraulic cylinder and ram. The work thus elevated is drawn over the top rolls to the front side of the mill, ready for its reintroduction between the rolls.

565. Three high rolls, introduced more particularly into mills for rolling light work, such as merchant or guide iron, but also adopted in some rail mills, consist of roughing and finishing rolls, each of which is a combination of three rolls in its own pair of housings. With three high rolls the mill is usually driven from the middle roll, although under special circumstances it may be driven from the lower one—that is, the engine shaft is coupled with the middle or lower pinion respectively, according to which method is pursued. In the three high train there are thus three pinions through which the rolls are driven, the wabblers ends of the pinions being coupled as before by spindles and coupling-boxes with the ends of the three

rolls ; and the middle roll therefore revolves forward with the lower one, and backwards with the upper one, or *vice versâ*, according to the direction of rotation of the middle roll, so that the work thus passes backwards and forwards alternately through the grooves or holes between the middle and bottom rolls, and between the middle and upper rolls respectively. The work, as it issues from the grooves in the lower rolls, is received and lifted (either by levers, or by a table ascending with the work, in the manner already described) to the level of the holes between the middle and upper roll, after passing through which the bar is received on the other side by a corresponding arrangement, and immediately lowered to the level of the lower pair of rolls.

566. In three high mills various mechanical arrangements are made for adjusting the distance of the top and bottom roll from the middle one. In two high mills, the top roll is movable for the purpose of adjustment, but in the three high system either the middle roll may be fixed and the top and bottom rolls run in adjustable bearings, or, as in Fig. 63, the bottom roll is fixed, and the middle and top rolls are carried in adjustable bearings. A three high 15-inch train for rolling merchant bars upon the first system with movable top and bottom rolls, has the bolsters or bearers on which the journals or necks of the middle roll work fixed solidly by bolts to shoulders in the housings or standards ; while the top and bottom rolls are raised or lowered simultaneously towards the middle or fixed roll by four housing screws, two in the top for holding down the top roll, and two in the bottom for elevating the bottom roll, and these four screws may all be revolved together by means of vertical shafts and attached gearing. The gearing revolves continually from the mill engine, but by an arrangement of belts and a friction clutch in connection with them, the housing screws are made to revolve in either direction or to remain stationary, and in this manner all four screws

revolve at once; but a greater degree of accuracy, especially for light work, is attained where means of adjusting the top and bottom rolls separately is adopted. In some English mills, like that illustrated (Fig. 63), the bottom roll is fixed and the other two rolls are adjusted by wedge-

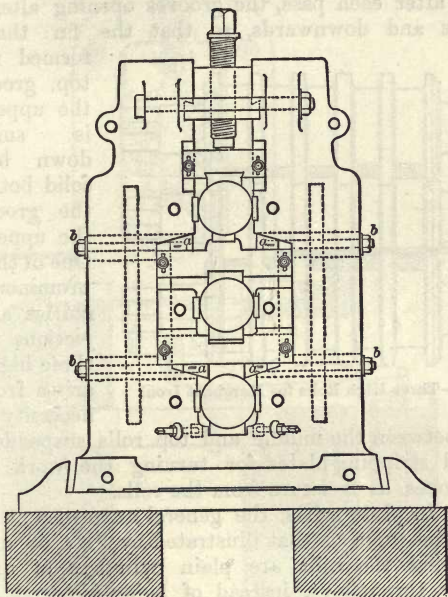

Fig. 63.—End Elevation of Housing for Three High Rolls.

shaped blocks, *a*, placed respectively beneath and above the bearers of the middle and top rolls, so that by turning the nuts, *b*, on the screwed ends of the wedges, they are drawn inwards or moved outwards, and so the position of the rolls adjusted.

567. In most American three high trains for merchant iron, the top and bottom rolls are grooved,

(Fig. 64), and the middle roll has the collars turned upon it, instead of grooving the bottom and middle rolls, as is often practised in England. The American plan requires shorter rolls for the same number of passes, and also does not necessitate turning over the bar after each pass, the grooves opening alternately upwards and downwards, so that the fin that was

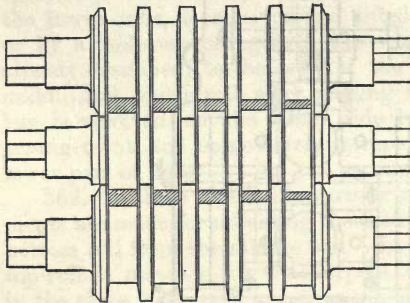

Fig.64.—Three High Rolls for Merchant Iron.

formed in the top groove in the upper pass is smoothed down by the solid bottom of the groove in the upper pass. One of the most prominent difficulties and objections to the three high mills arises from the necessity of providing

between the middle and top rolls suspended and balanced stripping-plates for turning the work out of the grooves as it issues from the rolls.

568. In plate mills, the general arrangement of the mill is the same as that illustrated by Figs. 59 and 60, except that the rolls are plain cylinders of uniform diameter throughout, instead of being grooved in the manner described for rail and other mills rolling merchant iron. And also the top roughing roll is balanced by counterweights in the manner shown in Fig. 65, whilst the top finishing roll is not coupled by spindles with the roughing rolls but runs freely, being revolved only by the friction of the work passing between it and the bottom roll. The plate mill consists, as before, of two pairs of rolls varying in different mills from 20 to 36 inches in diameter and from 4 to 9 feet in length. The

roughing rolls are grain-rolls—that is, such as are cast from a tough quality of cast-iron, not chilled on the surface—

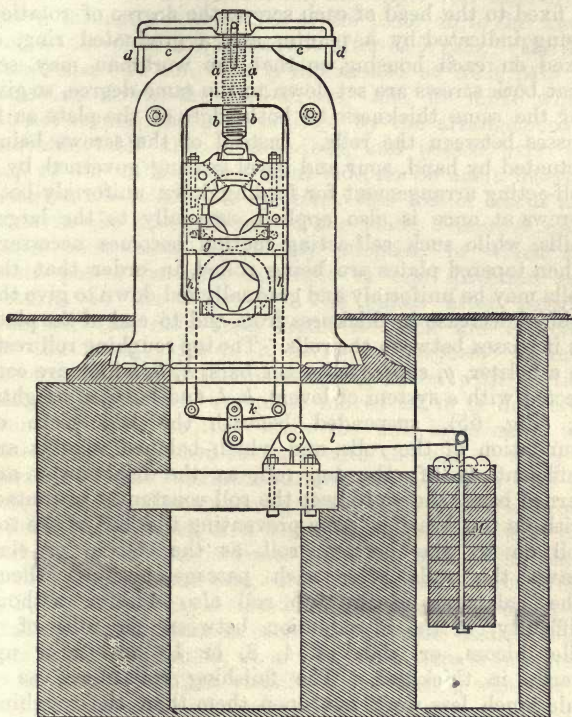

Fig. 65.—End Elevation of Plate Mill Housing, showing Balance Weights for Top Roughing Roll.

whilst the finishing rolls are chilled castings, of which the chill extends to a depth varying between $\frac{1}{2}$ inch and $1\frac{1}{4}$ inch. All the rolls run in brass bearings and are carried in housings, in the top of which are fitted nuts, *a*, and

setting-down screws, *b*, the movement of the setting-down screws being effected either by hand or by power. When the former plan is adopted a large hand-wheel, *d*, is fixed to the head of each screw, the degree of rotation being indicated by a pointer and a graduated ring, *c*, fixed on each housing, so that the workman may see that both screws are set down to the same degree, so giving the same thickness to both edges of the plate as it passes between the rolls. Instead of the screws being actuated by hand, spur and bevel gearing governed by a self-acting arrangement for feeding down uniformly both screws at once is also applied, especially to the larger mills, while such self-acting motion becomes necessary when tapered plates are being rolled, in order that the rolls may be uniformly and gradually fed down to give the desired decrease in thickness from end to end of the plate as it passes between the rolls. The top roughing roll rests in a bolster, *g*, supported upon bars, *h*, *h*, which are connected with a system of levers, *k*, *l*, and balance weights, *m*, (Fig. 65), suspended beneath the bed plate or foundation of the rolls, and which balance weights are sufficient to lift the top roll, as the feed-screws are turned back, and so to keep the roll constantly in contact with its top bearing, thus preventing the fall of the top roll on to the bottom roll as the bloom or slab leaves the rolls after each passage between them. The balancing of the top roll also admits, without difficulty, of the introduction between the rolls of a pile, bloom, or slab of 4, 8, or 10 inches or upwards in thickness. The finishing rolls have as a rule much less work put upon them than the roughing rolls, since the former usually reduce the plate but a fraction of an inch below what has been effected in the latter, but being truer on the surface than the roughing rolls they take out the buckling and any irregularities of thickness from the rough plate. The top *finishing* roll runs loose in its bearings and is neither balanced nor coupled by either gearing or spindles with the other rolls,

but revolves solely by the friction of the plate passing beneath it, as the plate is carried through by the rotation of the lower roll; and the upper roll thus drops down through the thickness of the plate on to the lower roll as the plate leaves the rolls after each pass. The distance apart of the rolls is diminished at each pass by screwing down the feed-screws, and in mills which do not reverse the plate is lifted by the arrangement of movable table already described, and passed over the top of the rolls to the front side, to be again inserted between the rolls. To overcome this loss of labour and time in the manipulation of the plate, *reversing mills* have been most extensively adopted, in which the plate passes between the rolls in one direction and returns in the opposite. The plates after passing between the rolls from front to back are received at the back side on a *horse* or *platform* inclined towards the rolls, the horse being fitted with friction rollers over which the plate moves as it is delivered from the rolls, so that when the mill is reversed the plate is easily pushed forward with the aid of tongs or bars down the inclined surface of the horse and so into the rolls, thus returning to the front side of the rolls where it is received on a bogie, which runs out with the end of the plate as it issues from the mill. The plate is thus easily passed backwards and forwards through the mill, the rolls being reversed and the screws set down to diminish its thickness at each pass, until the desired thinness has been attained, upon which the plate is conveyed to the mill floor in the vicinity of the shears, where it is laid down to cool and straighten if necessary.

569. In plate-mills and two high mills generally the top roll, as measured around the surfaces in contact with the metal, is made slightly larger than the bottom roll, so that the upper surface of the metal as it is rolled is thus extended a little more than the under surface and in this manner the leading end of the plate tends to curve downwards as it leaves the rolls; thus collaring around

the top roll is prevented, and stripping-plates are fitted as already described for preventing collaring around the bottom roll.

570. In passing through the plate-rolls the extension of the metal is almost wholly in the direction of its length, since, owing to the gripping together of the two rolls there is but little if any extension in width. Hence the bloom, slab, or pile, as the case may be, is first passed between the roughing rolls in the direction of the breadth of the plate so as to extend it to the full width required, after which the plate is turned round and passed into the rolls in a direction at right angles to its previous direction, or in the direction of its length. The operation of rolling is then continued by passing and repassing the plate through the rolls with a continued reduction in its thickness and a corresponding extension in its length, until the thickness required before transferring it to the finishing rolls has been attained, upon which the rough plate is passed to the harder and truer finishing rolls for finishing accurately to the requisite thickness; after which the plate is laid upon the mill floor to cool preparatory to transference to the shears, where the ends and sides are cut, as may be necessary, to reduce the plate to the necessary dimensions.

571. With iron plates formed from piles built up in a special manner, the plate is passed through the roughing rolls in the direction of its length and breadth alternately (with the object of attaining as much uniformity as possible in the strength of the plate in the two directions of its length and its breadth), until the full width of plate has been attained, after which the rolling is continued entirely in the direction of its length.

572. Sheet mills are similar in arrangement to the plate mills, except that the rolls are lighter and the mechanism required for manipulating the work at the rolls is neither so heavy nor so extensive. The sheet mills of Birmingham and of South Wales have rolls varying usually between 18 and 22 inches in diameter and from 3 to 6

feet in length, and run at from thirty to thirty-five revolutions per minute. For the production of the larger sheets in such mills, the billets employed are about $1\frac{1}{4}$ inch in thickness, and two of them are usually undergoing the rolling operation at the same time, passing between the rolls crosswise from the front side and then being returned by the back-hand over the top of the rolls to the front side, whilst the screws are set down to reduce the space between the rolls after each passage of the work. The plate is in this manner reduced to about $\frac{1}{8}$ -inch in thickness, when the two plates are placed one upon the other and passed together through the rolls for a few times, until finally two sheets each about 3 feet 6 inches wide by 5 feet in length are produced. The sheets are then annealed at a red-heat and, after reheating, are again returned to the rolls in pairs and further extended in length and diminished in thickness; whilst if the sheets are to be very thin each one is again doubled upon itself crosswise, reheated, and again rolled. The sheets thus produced are put on one side to cool, after which they are sheared to size, again annealed, and finally made into bundles for sale.

573. The *annealing* just mentioned is effected by placing the sheets in wrought-iron or steel annealing pots or boxes, which, when filled, are run into a reverberatory furnace and allowed to remain there for about twenty-four hours. The *annealing pots* vary greatly in size, some of the larger ones holding as much as eighteen tons of sheets, each 10 feet long, while the box for holding the same measures about 10 feet 6 inches in length, 5 feet 6 inches in depth, and 3 feet 6 inches in width. Such pots are charged by first piling up the sheets on a base plate, over which the cover or pot is turned and dropped as a cover over the pile, the box so prepared being luted up with clay around the joint of the cover and base plate. The whole is then inserted into the furnace, and heated as above, after which such a pot requires about four days to cool down after withdrawal from the furnace, before

the sheets are ready to be withdrawn. Very much smaller pots than the above are in use in South Wales for annealing purposes.

574. The so-called Universal or Belgian mill, for

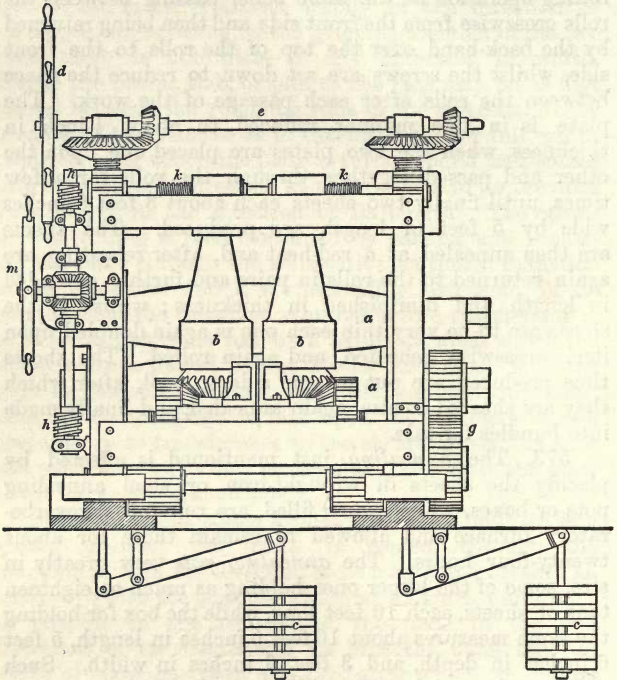

Fig. 66.—Universal or Belgian Rolling Mill.

rolling plates and bars, has two horizontal rolls, *a, a*, running in standards or housings, and geared together in the ordinary way; but the mill has in addition a pair of vertical rolls, *b, b* (Fig. 66), working in front of the horizontal rolls. The top horizontal roll is balanced by

counter-weights, *c, c*, after the manner of the plate-mill, so as to keep the roll against its top bearing. The distance between the rolls is regulated as usual by screws working through nuts in the top of the housings, which screws receive the necessary rotation either by two separate hand-wheels, or, as is more commonly the case, they are connected by suitable gearing with a shaft, *e*, actuated by one wheel, *d*, which is rotated either by hand or by steam power. The vertical rolls work upon slides, and can be moved towards each other or apart from one another by a right and left-handed screw, *k, k*, working in nuts carried upon the housings or bearings respectively of the two vertical rolls, and actuated by means of the worm-gearing, *h, h*, moved by a hand-wheel, *m*, which is under control of the workman. The vertical rolls are rotated from the driving pinion, *g*, of the mill through spur and bevel gearing so arranged that the bevel wheels slide along their shaft, and thus follow the lateral movement of the rolls as these are either separated or brought closer together.

The work as it passes through these rolls is compressed on the edge by the vertical rolls and on the flat between the horizontal rolls; so that a mill of this class may be employed for the production of a considerable variety of sections of flat bars by simply adjusting the horizontal and vertical rolls to the thickness and width respectively of the bars required.

575. Four high rolls have been employed for small mills with some measure of success in the rolling of wire rods for fencing and other purposes where small rolls only are required, but such mills are obviously impracticable for heavy work.

576. The size and speed of mills differ widely, according to the work upon which they are employed; thus whilst reversing mills for rolling heavy plates with rolls of from 20 to 36 inches in diameter revolve only at the rate of twenty-five or thirty revolutions per minute, the smaller mills, producing merchant bars or guide iron,

with rolls of from 12 to 18 inches in diameter, are generally speeded to run at the rate of from 80 to 125 revolutions per minute; and the still smaller mills, such as those rolling billets into wire, with rolls of from 8 to 12 inches in diameter, run at from 250 to as much as 500 revolutions per minute. The roughing rolls, again, in reversing mills rolling iron rails, and having rolls of from 20 to 24 inches in diameter, run at about 30 revolutions per minute, although when the mill is non-reversing, the speed considerably exceeds this figure. Mills rolling steel usually run 25 or 30 per cent. faster than the corresponding mill working upon iron, while the power required to roll steel, largely owing to the much lower temperature to which the metal is heated, is considerably in excess of that necessary to roll the same section in iron.

577. In *rolling steel rails* at the Crewe Works the mill runs at the rate of forty-five revolutions per minute, and a $10\frac{1}{2}$ -inch steel ingot is cogged down in the roughing rolls, and is completed in the finishing rolls at the same heat into a 30-foot rail weighing 84 lbs. to the lineal yard, passing seventeen times through the grooves of the rolls during the operation, and occupying altogether about two minutes for its completion. It may be noted in passing that when the rail leaves the finishing rolls it is carried along upon a series of five rollers in the floor opposite the rolls, (and which are revolved by suitable power and gearing,) to a circular saw of 8 feet in diameter, where the ends are cut square and to the exact length, and subsequently, after the rails have become cold, they are straightened in a horizontal straightening press, and then passed on for drilling at either end under double-drilling machines, as required for the fish-bolts.

578. The usual time occupied in England in rolling a double length of steel rail with six roughing and five finishing passes is a little over two minutes. In the American mills, driven *feed-rollers* like those just mentioned for receiving the rail from the mills are

employed both in front and in the rear of the rolls wherever heavy work is manipulated.

579. In some of the American mills rolling steel rails, the rails are rolled in a single length of 90 feet, sufficient for three ordinary 30-foot rails, into which lengths the long rail is cut by the hot saw. For this purpose the Bessemer ingots are cast 14 inches square and weigh about one ton each; such ingots, after reheating, are passed to a three high blooming or cogging mill running at the rate of forty or forty-five revolutions per minute, and through which the ingot makes from eleven to thirteen passes in from one and a-half to two minutes, producing a 7-inch bloom which, as it leaves the last roughing pass, is transferred by the rollers, previously described, to the rail or finishing mill, consisting of a 21- to 24-inch train, running at seventy-five revolutions per minute; through this mill without any reheating the bloom makes other seven or nine passes, issuing as a 90-foot rail, which is then cut up into three lengths by the hot saw. The whole operation between the reheating furnace and the rail bank occupies but from three to four minutes, and when cold, the rails are transferred to the drilling machine. In some mills of recent date, both English and American, the rails are rolled in lengths suitable for cutting into four ordinary 30-foot rails.

580. The **slitting mill** for the production of "slit" or "nail rods" consists of a pair of rolls, housed in the usual manner, but which are made to act as a compound shearing machine, for which purpose collars acting as circular cutters are specially turned upon the rolls; or, instead of being turned upon the roll itself, separate steel collars or discs are fitted upon a spindle or arbor, stops being introduced between the discs for keeping them apart to the required distance. The discs or collars are so arranged that those on the upper roll fall into the space or groove between the collars on the lower roll, leaving however sufficient space between the top of the disc and the bottom of the corresponding

groove to admit of the thickness of the metal that is being cut by the mill. Flat bars pushed into such a mill in the same manner as they would be between the rolls of an ordinary mill, are divided or cut during their passage through the rolls, so as to be delivered at the opposite side or rear of the mill as a series of bent and twisted strips or rods of rectangular section, requiring to be straightened by hand and made into bundles, when they are ready for sale to the nail forgers. The bars, on entering the slitting mill, are steadied by guides, and the cutters are cooled by water continually running over them.

581. **Rolling mill engines** vary considerably in type and power; they are made direct-acting, high-pressure, either non-condensing, condensing or compound, while both vertical and horizontal types are employed; but *non-reversing*, high-pressure, non-condensing engines with heavy fly-wheels, are usually adopted for the smaller mills rolling merchant and guide iron in two or three high mills; whilst for the heavy mills producing iron and steel plates, rails, heavy angles, sections, and the like, *reversing* mills are the more usual.

582. *Reversing Mills* are usually driven by horizontal engines either of the high-pressure or of the compound type; such engines being fitted either with variously designed friction clutches, hydraulic clutches, differential gear, &c., for effecting the reversal of the rolls whilst the engine moves constantly in the same direction; or, as is more general, the engine itself for reversing mills is reversed at each pass of the work between the rolls, according to the plan introduced by Mr. Ramsbottom, and hence generally known as the Ramsbottom reversing mill engine, but it is altered or modified to suit the special conditions of different mills. A pair of recently constructed high-pressure and non-condensing engines of this type are represented in Fig. 67. The pair of engines are coupled to two cranks placed at right angles on the same shaft, upon which is also a steel pinion, *p*, gearing into a steel wheel, *w*, on the second motion shaft, the latter being in line with the bottom roll

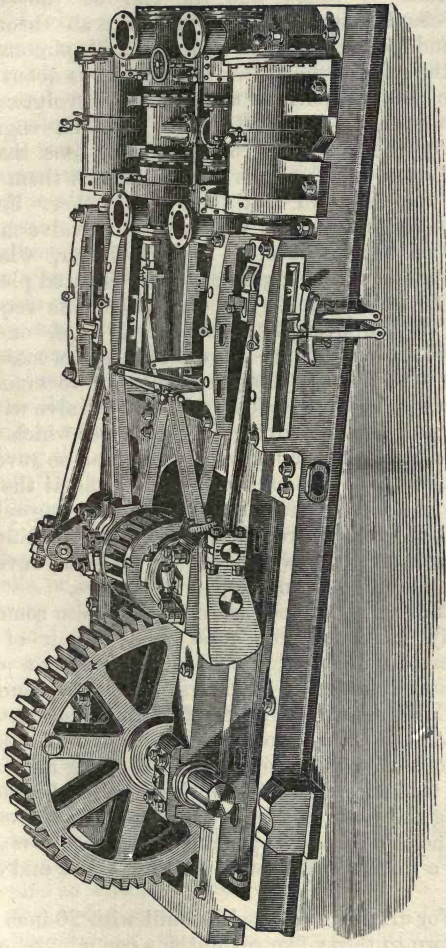

Fig. 67.—Reversing Rolling Mill Engines.

of the train of rolls; and the end of the engine shaft is coupled by a claw-clutch or crab through a spindle and coupling-boxes with the mill pinions, and so on to the rolls of the mill. The gearing is about three to one, so that the engine makes three revolutions for each revolution of the mill rolls. Such an engine is without fly-wheel, and is reversed each time that the heat passes through the rolls and so rotates them alternately in one direction and then in the other. For this purpose the engine is fitted with a slot-link valve motion, and the reversal is effected by the driver, who sits either alongside of the engine or on an elevated platform above, so as to be able to see the movements required, and, by moving over the two levers, *d*, *d*, one connected with an equilibrium valve on the steam main, and the other with a small steam cylinder for reversing the engine, he is able, by first closing the steam valve with the one lever, and then by moving the other lever which works the small steam cylinder just mentioned, and so reversing the link motion, to control the engine; while at the same time the too sudden reversal by the small reversing cylinder is prevented by the introduction of a water cylinder or cataract arrangement, which, along with the reversing engine, is placed between the pair of engines.

583. Reversing engines are now made also somewhat extensively upon the compound type; a pair of such engines, erected for rolling steel plates, having a pair of high-pressure cylinders of 24 inches in diameter, connected with two low-pressure cylinders of 44 inches diameter.

584. At the Crewe works a three high rail mill, the cogging rolls of which are fitted with rising and falling hydraulic tables for lifting the work to the level necessary for passing the work between the middle and lower or between the middle and upper roll respectively, is being driven by a Corliss engine with 4-foot cylinder and 5-foot stroke.

585. For driving a single-sheet mill with 20-inch rolls, at thirty-two to thirty-five revolutions per minute, a non-

condensing engine with 27-inch cylinder and 5-foot stroke, having a fly-wheel weighing 10 tons, and running at seventy revolutions per minute, has been applied; or, for driving a double-sheet mill under like conditions of speed and pressure of steam, an engine with 35-inch steam cylinder and 5-foot stroke, with a fly-wheel of 70 tons in weight, is in use; while, as another example of the power required to drive a sheet-mill, may be cited an engine at work at Messrs. Morewood's, Birmingham, for driving a 21-inch mill making thirty to thirty-five revolutions per minute, and capable of rolling sheets of 4 feet in width and of 30 B. W. G. in thickness, in which the steam cylinder is 30 inches in diameter, with a 5-foot stroke, and works direct without the intervention of gearing, and has a fly-wheel 25 feet 6 inches in diameter and 60 tons in weight. It is calculated that in a mill such as the last mentioned a force of about 400 tons tending to separate the rolls is exerted during the process of rolling the above sheets.

586. The method and particular arrangement observed in building up or *piling* the bars and slabs of malleable iron into packets or piles for reheating and welding together into a solid mass, either under the hammer or in the rolls, or by a combination of the two processes, varies for every class and quality of work, and for the same kind of work different makers also follow different practices often peculiar to themselves.

587. For the production of No. 2 iron the bars of No. 1 are cut up into lengths, and the pieces so obtained are arranged, if for the production of the larger sizes of merchant iron, into the form of a pile or stack of some 6 or 8 inches square and from 30 to 40 inches in length, such piles averaging about 4 cwts. each, and their constituent bars are placed so that the joints of the several bars do not fall one above the other, but always cross or break joint. The pile so formed is held together by an iron hoop, and after being raised to a welding heat in the reheating or balling furnace, the several bars of the pile are welded

together by passing the pile through grooved rolls in the manner already described; or the welding together may be effected by first hammering and subsequently drawing the hammered bloom into bars by passing the same through the grooves of the bar or guide-mill. For smaller bars the piles of about 100 lbs. each are only about 18 inches long and from 3 to 4 inches square, formed from flat bars of about $\frac{3}{4}$ inch in thickness but, as already noted, p. 324, billets are more generally used for these smaller sizes.

588. In like manner, for the production of iron plates the piles vary in size with that of the plate to be rolled, but the pile is formed by placing the component bars in layers, of which the bars in one layer are placed across those of the layer beneath, and so on until the whole pile is built up to the top layer, which is covered like the bottom by a slab of about $1\frac{1}{2}$ inch in thickness, and of a length and width suitable to the dimensions of the particular plate which it is designed to produce. Scrap and crop-ends are also built up along with the puddled bar in these piles.

589. For iron rails, again, some eighteen or twenty pieces of puddled bar, each about 3 inches wide and $\frac{5}{8}$ th inch in thickness, are arranged along with scrap-iron in the middle of the pile, while the top and bottom iron plates or slabs are each formed either of a plate of No. 2 iron of 6 or 7 inches in width and 1 inch in thickness, or of a puddled bloom which has been already doubled over upon itself, and previously rewelded. Care is observed in rolling such a pile that it be so passed through the various holes of the rolls that these top and bottom plates are eventually rolled into the two heads of the rail.

590. As already noted, for the production of No. 2 and the higher qualities of iron, as also of plates, rails, tees, angles, &c., in malleable iron, the puddled bar, after being cut under the shears into suitable lengths, is piled along with scrap-iron, crop-ends, &c., into piles for reheating, welding together, and drawing into bars, &c., in

the mill rolls. This process of piling is not carried on at random, but a regular method of placing the bars is observed, and in many works special care and attention are paid to the quality of the iron introduced into the several parts of the same pile, as also in the arrangement of the constituent bars with regard to the section to be rolled, so as to produce the best result as to strength and ductility, both with and across the fibre or grain of the finished iron after welding up and rolling.

591. In the *production of small round or square bars of merchant iron*, the piles, after heating and hammering or rolling into square bars of $1\frac{1}{2}$ inch or 2 inches square, are then cut under the cropping shears into lengths or billets of from 12 to 24 inches according to the weight of bar required, and these billets are afterwards reheated in a small reheating furnace, which is kept filled by the introduction of cold billets as the others are heated and withdrawn for rolling in the finishing rolls into small bars.

592. Since, in the welding together of the component bars in a pile, butt joints unless covered by other bars or plates do not weld properly, it is usual to form the top and bottom members of such piles by single bars or slabs. Thus, in piles for rails the top and bottom layers are made up of slabs produced by the doubling over and welding together under the hammer of two or more puddled blooms, without the same having been previously rolled into bars in the puddling mill; but the hammered blooms so produced are reheated and rolled into the desired slabs. The ends of the bars, for like reasons as to difficulty of welding, should be cut square, and the bars should also be as free as possible from all scale, dirt, rust, or other foreign matters which interfere with the welding together of the constituent bars of the pile, and hence with the homogeneity of the finished bar.

593. The piles, as made in South Wales, for rolling into rails weigh about 15 cwts. each, and four of these are placed at the same charge into the reheating furnace,

and the heat (charge) is rolled into blooms, which are then returned to the furnace for about thirty minutes to be again reheated, after which they are passed to the mill, and in nine passes through the rolls such blooms become finished rails ready for cutting to length, and subsequently drilling or punching for the fish-plate bolts.

594. With *steel* the above operations of *piling and reheating for welding are not carried on*, the steel being always cast into an ingot of sufficient weight for the production of the desired bar, plate, rail, &c., and which ingot is usually reheated before rolling, unless, as in the arrangement of Mr. Gjers, the large ingots required for rails, &c., are placed in "soaking pits" (p. 382), whence they are directly transferred to the hammer or rolls as the case may be, to be drawn down into blooms and slabs, and then either at the same heat or after reheating, are passed to the mill for rolling into rails, plates, bars, etc. For the heavier classes of work, such as rails, &c., the practice of cogging and rolling direct from the ingot without the intervention of the hammer has become universal; whilst for the production of the heavier class of plates this practice is also coming more and more into favour. For the treatment of such heavy steel ingots in the cogging or roughing rolls, either after reheating or direct from the soaking pits, very large and strong rolls are required, and such are now being introduced for this purpose up to 36 inches in diameter.

595. The *crop-ends of rails, angles, heavy sections, bars, &c.*, are cut off immediately the work leaves the rolls and whilst the metal is still hot; for which purpose the rail or bar, &c., is drawn from the rolls to the front of a *circular saw* of from 4 to 8 feet in diameter, and which runs at the rate of from 800 to 1,200 revolutions per minute. The saw is carried in a swinging frame which can be moved out towards the work by a rack and pinion arrangement controlled by the workman, which thus, amid a shower of sparks, rapidly cuts across the work, leaving the ends comparatively clean and square.

596. Puddled bars are also generally sheared hot either by crocodile or guillotine shears into lengths suitable for piling, &c., and such shears are likewise employed for cutting up the bars that are not cut up by the hot saws, as also for cutting off the rough or crop-ends of puddled,

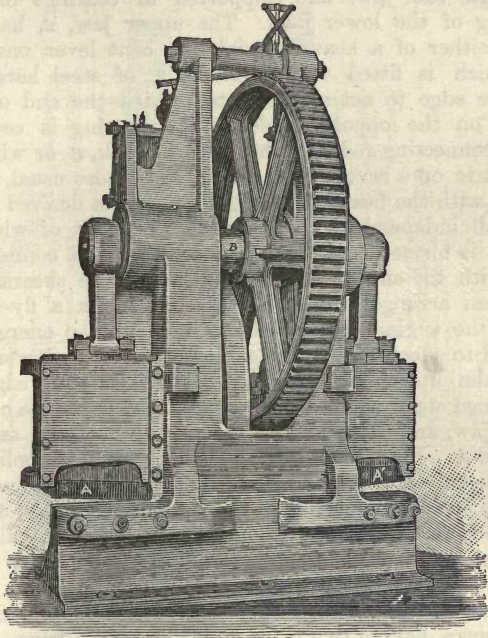

Fig. 68.—Shears for cutting up Puddled Bars and Slabs.

finished, or other bars, and occasionally also for dressing the sides and edges of plates and shearing them to size; although for this latter process larger and broader-faced guillotine shears (Figs. 69, 70) are more generally adopted, except for the smallest and lightest plates or sheets where the crocodile or alligator shears are still in use.

597. The crocodile, cropping, or alligator shears, by which names the same tool is known, has two jaws, the lower, D (Fig. 70), of which is fixed, and either forms part of the cast-iron foundation or is secured to it, whilst the other jaw, E, vibrates or oscillates on a pin passing through the jaw, and supported in bearings on the casting of the lower jaw. The upper jaw, E, has the form either of a heavy straight or bent lever, one end of which is fitted with a blade, F, of steel hardened on the edge to act as the cutter, whilst the end of the lever on the opposite side of the bearing is coupled by a connecting rod, G, either with a crank, H, or with an eccentric on a revolving shaft, or, as is more usual, especially with the heavier shears, the power is derived from a small independent engine, upon the shaft of which a crank is formed and the same coupled by a connecting rod with the end of the moving jaw of the shears. In such an arrangement it is necessary to fix a fly-wheel upon the engine shaft so as to store up the energy required to effect the shearing operation. The lower jaw like the upper one is fitted with a cutting edge of hardened steel, which works opposite to the blade on the fixed jaw, and these knives are readily replaced as they wear out. Fig. 70 shows a crocodile shears as applied to a powerful plate shears, where it is employed for cutting up the scrap produced from the shearing of plates, &c.

598. A form of powerful guillotine shears applied to the cutting up of puddled bars and slabs, and which is replacing in the newer works the older crocodile shears, is represented in Fig. 68. This machine cuts on either side of the centre, having two pairs of blades, A, A', driven from cranks at either extremity of the same shaft, B, exactly in the manner of the ordinary shearing machine, and its action will be thus evident without further description.

599. The *shearing machine* represented by Figs. 69 and 70 is employed in several of the large iron and steel works for shearing heavy plates. It consists of a cast-iron framework, made in two halves and bolted

together in the centre. On the face of the standards or framing, and working upon suitably prepared surfaces, is the apron or slide, B, in the lower edge of which is fitted the steel-faced blade or cutter, *b*, the lower cutting edge of which makes an acute angle with the horizontal lower

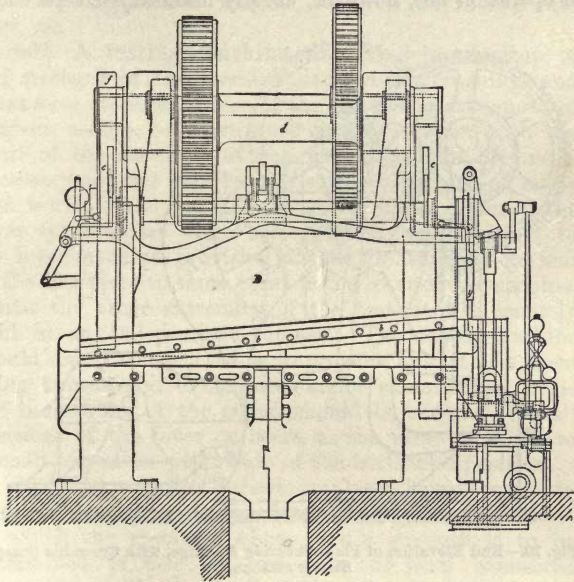

Fig. 69.—Front Elevation of Plate-Shearing Machine

cutter, *c* (Fig. 70), which is carried by the fixed foundation. Across the front of the machine and working in brass bushed bearings, is a steel shaft, *d*, upon which are forged two eccentrics, connected by powerful straps and links, *e, e*, with the top of the slide, which thus ascends and descends as the shaft revolves. At one end of the machine is an engine with a heavy fly-wheel, *f*, and the power is transmitted between the engine shaft and the ec-

centric shaft, *d*, through heavy spur or helical gearing, as shown. The slide or apron, *B*, is further fitted with a stop motion worked by the handle, *y*, whereby the descent of the slide can be prevented during the time that the plate is being moved forward and properly set after the last cut, an operation not, however, usually necessary except with

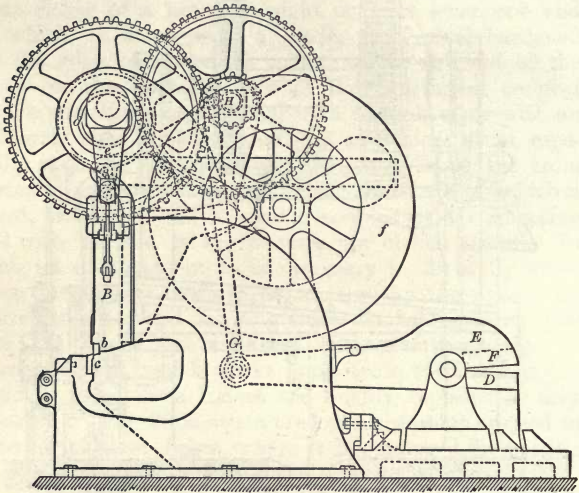

Fig. 70.—End Elevation of Plate-Shearing Machine, with Crocodile Scrap Shears attached.

the heaviest plates. Such a machine as that represented in Figs. 69 and 70 is calculated to shear through cold iron plates $1\frac{1}{2}$ inch in thickness, while the slide is made from 7 to 11 feet in length, and the distance between the two inner faces of the two sides or standards of the machine measures from 5 to 9 feet, according to requirements. For lighter work machines of the same class are employed, but they are made proportionately lighter and less powerful.

600. Guillotine shears of great power, upon the type just described, but very narrow across the face—*i.e.*, between the sides of the machine—are also being made and erected in steel works for cutting up whilst hot steel ingots or blooms of from 3 to 8 or 10 inches square, into the lengths and weights required for rolling into bars, &c.

601. A testing-machine for the determination of the strength of the metal under tensile, crushing, and transverse stresses, as also of the increase of its length in a given section before rupture occurs, together with the limit of the elasticity of the metal, &c., has become a necessary adjunct of all large steel works, and of many iron works. The machines so employed are either of the lever type, or are direct-acting hydraulic machines; in the lever machines provision is made for attaching one end of the test-piece to some point in the lever of the machine, whilst the other extremity of the test-piece is securely held in an independent support. The testing-machine should be so constructed as to prevent any shocks from being transmitted to the piece under examination, while the indications of the stress should be accurate for all positions of the lever or beam, as the same oscillates to a small extent on either side of the horizontal position.

602. The machines hitherto employed have been mostly designed upon the lever type introduced by Mr. Kirkcaldy, in which the specimen whose tensile strength is to be determined is held by two pairs of jaws connected respectively with the head of the ram of an hydraulic cylinder and the short end of the lever of the machine, when by means of an hydraulic force pump, the ram or plunger of the hydraulic arrangement can be forced out so as to put a tensile stress on the bar or plate under examination, and which stress is resisted by a weight upon the long arm of the lever above mentioned. Hence, by knowing the amount of weight and distance along the lever at which it has been applied, the stress upon the test-piece can be calculated, while its effect upon the

sample is noted. The arrangement, as just sketched, of a machine with a single lever, necessitates however the employment of heavy weights or of very long levers, and it is more usual to use a smaller weight connected with a system of compound levers for multiplying the stress corresponding to any given weight; but Mr. Wicksteed* has described a single lever metal testing-machine well adapted for the ordinary testing purposes of the manufacturer, where minute accuracy, such as may be necessary for the purely scientific investigator and the recording of his every step, is not required. In this machine the multiple levers are abandoned and replaced by a single lever, *L*, with a moving weight, *M*, of one ton in weight; one end of the test-piece, *t*, is connected by clips, &c., to knife-edges on the beam, *L*, whilst the other extremity of the test-sample is likewise coupled by similar clips to a bonnet screwed on to the end of the hydraulic piston, *a*, of the pulling cylinder, *b*. The beam or lever, *L*, oscillates through a small arc upon knife-edges supported by the standard, *B*, whilst the weight, *M*, can be moved along the lever by a screw, actuated by the hand-wheel, *m*. The machine is so arranged that the weight, *M*, can be moved to the extremity of the shorter end of the lever, in which position it exactly balances the long end of the lever and the other connections suspended from it, and this point marks the zero of the graduated scale, *n*, attached to the lever, and over which a pointer carried by the weight, *M*, travels as the weight moves along the lever. The distance between the point of suspension of the test-piece and the fulcrum or centre of oscillation of the lever is exactly 3 inches, and thus, as the weight, *M*, of 1 ton moves towards the end of the lever, each 3 inches of its traverse indicates an additional stress of 1 ton upon the test-piece. The clips or jaws for holding either extremity of the test-piece are steel plates, parallel and serrated on their inner faces in the manner indicated at *G G* (Fig. 2, p. 3), but tapered at the

* Proceedings Institute of Mechanical Engineers, 1882.

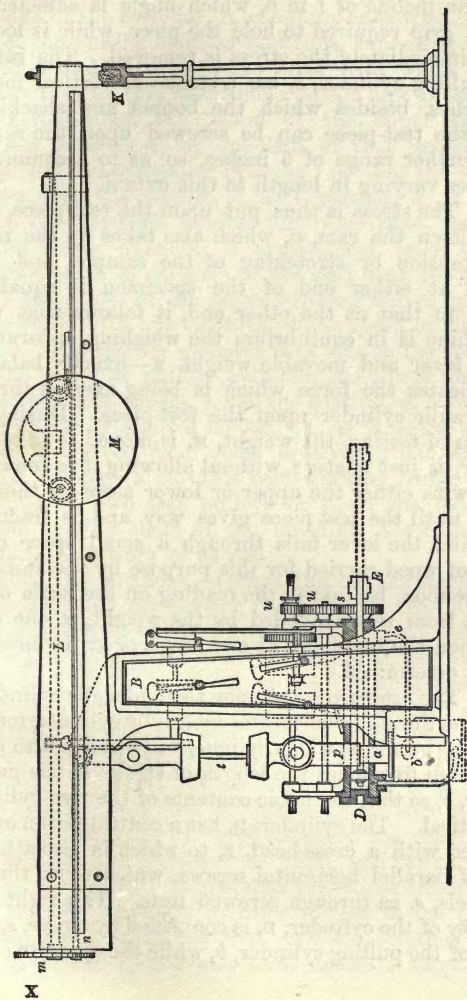

Fig. 71.—Single Lever Metal-testing Machine.

back to an incline of 1 in 6, which angle is sufficient to give the grip required to hold the piece, while it loosens its hold immediately the stress is removed. The ram, *a*, of the pulling cylinder, *b*, has a stroke or vertical motion of 6 inches, besides which the bonnet and shackle, *p*, holding the test-piece can be screwed upon the ram, *a*, over a further range of 6 inches, so as to accommodate test-pieces varying in length to this extent.

603. The stress is thus put upon the test-piece, *t*, by forcing down the ram, *a*, which also takes up the necessary extension or stretching of the sample, and since the pull at either end of the specimen is equal and opposite to that at the other end, it follows that when the machine is in equilibrium the weighing apparatus—*i.e.*, the lever and movable weight, *M*—exactly balances, and indicates the force which is being exerted through the hydraulic cylinder upon the test-piece. During the operation of testing, the weight, *M*, is moved so as to keep the lever, *L*, just floating, without allowing it to come into contact with either the upper or lower stops on the standard, *K*, until the test-piece gives way and is fractured, upon which the lever falls through a small space on to a block of wood carried for this purpose by the standard, *K*, whereupon, by taking the reading on the scale of the distance from zero travelled by the weight, *M*, the exact stress upon the test-piece at any stage, or at the breaking point, is determined.

604. The pressure is put upon the hydraulic cylinder, *b*, and ram, *a*, through a horizontal hydraulic cylinder, *D*, at the back of the machine, which cylinder has but one-fifth of the area though five times the length of stroke of the pulling cylinder, *b*, so that the cubic contents of the two cylinders are identical. The cylinder, *D*, has a central piston or ram connected with a cross-head, *E*, to which is also attached a pair of parallel horizontal screws, which work through the wheels, *s*, as through screwed nuts. The right-hand extremity of the cylinder, *D*, is connected by a pipe, *e*, with the top of the pulling cylinder, *b*, while the opposite end or

left side of the cylinder, *D*, communicates with the lower end of the pulling cylinder and thus, supposing that both cylinders and pipes are quite filled with water or oil, it follows that by this mechanical device any pressure that is exerted upon the piston of the larger or pulling cylinder is balanced by one-fifth of that pressure upon the piston of the smaller cylinder; so that the horizontal screws with the wheels, *s*, and gearing, *u, u*, through which the power for forcing the water from the smaller to the larger cylinder is transmitted, only sustain a pressure equal to one-fifth of the load upon the test-piece, while the piston of the larger cylinder moves upwards or downwards with but one-fifth of the speed of the smaller piston. The smaller cylinder thus acts as the force pump for the larger or pulling cylinder, the power for rotating the screws and wheels, *s*, and the gearing, *u, u*, being supplied either by manual labour, or, as is more usual, the power is derived from some revolving shaft, and transmitted through a movable belt working either upon one or other of two fast pulleys or upon one loose pulley on the driving shaft of the machine, according as the machine is at work or at rest.

605. The furnaces, or reheating arrangements of the forge and mills, for heating the piles, blooms, billets, &c., of wrought-iron, or the ingots, slabs, blooms, billets, &c., of steel, to prepare them for treatment under the hammer or in the rolls, or by both, are (1) the *open fire*, as used in conjunction with the finery, and already described (p. 237); (2) the *hollow fire*, as employed in South Wales for reheating the piles or stamps in the manner described (p. 233); (3) the *reverberatory* or *balling furnace* of the forge, and the *reheating* or *mill furnace* as usually constructed for mill purposes for reheating iron or steel for the hammers or rolls; and (4) the *soaking-pits* of Mr. Gjers. Of the four types just enumerated, it will only be necessary to refer further to the third and fourth types, since the first two are confined in their use to certain special and local methods adopted in the

manufacture of malleable iron, as already described, while the method of soaking has only been proposed for the treatment of steel ingots.

606. The forge reverberatory, or balling furnace, is most generally constructed and arranged to burn raw coal or other solid fuels upon its own grate-bars; whilst the *reheating furnaces* for the mills and forging hammers, although still constructed in some works to burn only solid fuel on their own grates, are yet frequently replaced by furnaces burning gaseous fuel; and in steel works the furnaces employed for heating steel ingots, billets, blooms, slabs, &c., are almost universally constructed for the combustion of gaseous fuel in the manner proposed and carried out by Siemens, Bicheroux, Ponsard, Boëtius, &c., &c., so that furnaces consuming solid fuel directly upon their own grates are now the exception in steel works.

607. The reheating, mill, or balling furnace, adapted to the consumption of raw fuel direct upon its own grate, resembles in external appearance and form an ordinary puddling furnace, and, like it, is supported (Fig. 72) externally by cast-iron plates and buck-staves, *a, a*, secured from side to side and from end to end by wrought-iron tie-rods passing over the top, and secured to the plates by nuts on the screwed ends of the tie-rods. The balling furnace has a smaller area of grate-bars than the puddling furnace in proportion to the area of its bed; the chimney, *b*, is also a little higher, and 8 or 9 inches wider, than would be the case for the same area of hearth in a puddling furnace, whilst the formation of the bottom of the furnace is also different: for while the mill furnace bottom is formed of sand on the top of a fire-brick lining, the puddling furnace, as previously noted, is made and fettled with furnace cinder and certain ores of iron. This type of furnace is employed more particularly in iron works for raising to a welding heat the piles of puddled bar or the higher grades of malleable iron, previous to the rewelding of the same under the

hammer, or in the mill rolls ; but they are now only very rarely employed for reheating steel ingots or blooms in preparation for the rolling mills.

608. *Balling furnaces* differ in size, form, and number

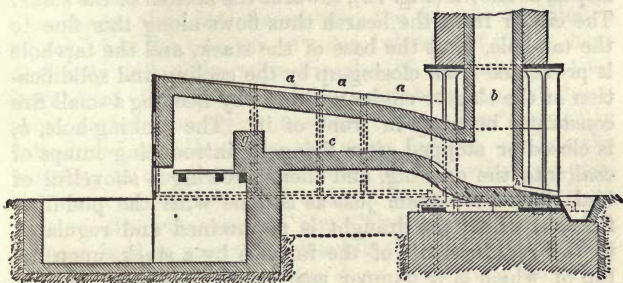

Fig. 72.—Vertical Section of Reheating or Balling Furnace.

of their doors according to the nature of the charges they are intended to receive. As constructed for reheating the piles, &c., for rolling into merchant iron, and as built for the South Wales forges, the bottom of the hearth is

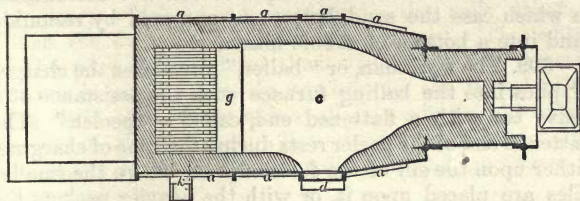

Fig. 73.—Plan of Bed of Reheating or Balling Furnace.

made of cast-iron plates fixed about 14 inches below the working door, and upon this is laid a course of fire-bricks upon which the working bottom is made by well ramming in sand in a moist state. The bottom or bed, *c*, slopes uniformly from the working door, *d* (Fig. 73), to the back

of the hearth, as also from the fire-bridge, *g*, to the stack, *b*. The fire-bridge is built about 9 inches in width, and reaches to within about 14 inches of the roof, and the chimney or flue-end of the hearth is rounded off, and slopes, as shown (Fig. 72), towards the bottom of the stack. The cinder from the hearth thus flows along this flue to the tap-hole, *h*, at the base of the stack, and the tap-hole is prevented from closing up by the cooling and solidification of the slag or cinder within it by keeping a small fire constantly burning in front of it. The stoking-hole, *k*, is closed or stopped after firing by introducing lumps of coal into the opening, and then throwing a shovelful of coal slack over them just as is done with the puddling furnace, whilst the draught is maintained and regulated to the requirements of the furnace by a stack, upon the top of which is a damper suspended from one end of a lever, from the other end of which hangs a rod reaching to the floor level. The height, as given above, of the roof from the bed of the furnace is adapted to the production of merchant iron of ordinary sizes, but for the heating of large slabs or forgings the roof may be raised, and the size of the doors increased considerably. In some furnaces, also, the cast-iron bed-plates are not introduced, in which case the sand bottom is prepared by ramming sand into a bottom of rubble masonry.

609. The workman, or "baller," introduces the charges of piles into the balling furnace with the assistance of a heavy bar with a flattened end, called a "peeler." The flattened end of the peeler rests during the time of charging, either upon the sill of the furnace door, where the smaller piles are placed upon it, or with the heavier packets the peeler with the pile upon it is carried upon a bogie, which delivers it at the height of the furnace door. In either case, the peeler with the pile upon it is pushed into the furnace, and the peeler is then withdrawn in such a manner as to leave the pile standing across the furnace parallel with the fire-bridge, when the end farthest from the charging door following the incline of the bed of the

furnace thus stands about 6 inches lower than the end nearest the door. For the production of merchant bars, four such piles are inserted into the furnace at one charging or heat, care being taken not to disturb the bars making up the pile during the charging of the same. The charge thus introduced into the furnace is called a "heat," but the number of piles introduced for a heat obviously will differ with the size of the same, so that instead of four piles, as above, making up the heat, some sixteen or eighteen smaller piles are frequently introduced as a heat for the same furnace. When the charging is completed, the door is lowered into position, and a shovelful of coal is thrown around it to prevent the admission of air. The temperature of the furnace is then raised by cleaning the grate-bars, adding more fuel through the stoking door, re-stopping the latter with coal, and then raising the chimney damper. In this manner the larger piles first mentioned will attain to a welding heat in about one hour, or with the smaller piles thirty minutes will suffice to raise them to a welding heat, at which temperature they are withdrawn from the furnace by seizing each one separately with a pair of tongs and drawing it forward on to a bogie in front of the door, which is run rapidly to the rolls, through which the dripping pile is at once passed. The whole of the piles having been thus withdrawn, the furnace bottom is usually slightly repaired by the introduction of a little sand, after which all is ready for the introduction of another heat. The withdrawal of the charge and repair of the bottom usually occupy from fifteen to twenty minutes.

610. During the reheating of piles or of ingots they are moved about a little to promote more rapid and uniform heating over the whole surface of the mass, otherwise the lower side, being in contact with the bottom of the furnace, is not exposed like the upper surface to the action of the flame within the furnace, and would hence remain comparatively cold for a much longer period than the top

of the pile or ingot, &c.; while, as the mass approaches a welding heat, oxidation and scaling of the iron proceed somewhat rapidly, and such scale falls on to the bottom of the furnace, where it combines with the silica or sand of the bottom with the production of a readily fusible slag or cinder, which flows away freely to the bottom of the stack, from whence it escapes by the tap-hole already mentioned.

611. The flue-cinder, or mill furnace slag, thus produced during the balling or reheating process is essentially a bibasic ferrous silicate of iron, containing from 50 to 60 per cent. of ferrous oxide, representing from 40 to 45 per cent. of metallic iron, the other constituents of the cinder being about 30 per cent. of silica, with small percentages of ferric oxide, manganous oxide, alumina, lime, magnesia, sulphur, and phosphoric anhydride.

612. The consumption of coal in the production of No. 2 merchant iron from the ore, embracing that consumed in the calcination and smelting of the ore, the puddling of the pig-iron, and the reheating for rolling into No. 2 quality of iron, is, roughly, about four times the weight of the bars produced; and there is an additional consumption of from 9 to 10 cwts. of coal per ton for each additional piling and reheating necessary for the production of each higher grade of merchantable iron; so that to make treble-best iron nearly 6 tons of coal are consumed per ton of bars, whilst steel bars can be produced with the consumption of about 3 tons of coal per ton.

613. The yield of merchantable iron per ton of pig-iron treated differs with the locality, the quality of the pig, the skill of the workman, and the quality of iron produced, or the number of separate pilings and reheatings to which it has been submitted; but the average loss in the Staffordshire district is about 25 per cent., and in South Wales it is somewhat greater. Thus the loss in the Dudley district of Staffordshire between the pig-iron treated and the *puddled bars* produced is about 10 per cent., or, more accurately, 24 cwts. of pig-iron usually

yield 22 cwts. of puddled bars, while $22\frac{1}{2}$ cwts. of the latter are required to produce a ton of merchant bar.

614. The loss in rolling steel is not nearly so great as in iron, since the piling and welding processes are unnecessary, while lower temperatures with a proportionately smaller oxidation and loss are adopted throughout the manipulation of steel; thus, in rolling rails from steel ingots with the adoption of the soaking-pit arrangement of Mr. Gjers for the heating of the ingots, and one reheating of the 8-inch blooms produced by the cogging of the same, the loss, including crop-ends, at the West Cumberland Steel Works,* over a week's working was only 12 per cent. of the weight of ingots charged.

615. Gas furnaces have been extensively introduced, instead of the reheating or balling furnaces heated in the manner last described, by the combustion of solid fuel upon the grate-bars of the furnace itself. Gas furnaces for reheating purposes are of the reverberatory type, either upon the *regenerative principle* of Sir W. Siemens, or, like those of Bicheroux, Boëtius, &c., without regenerators; but they are all heated by the combustion of *gaseous fuel* produced either in separate *producers* or gas generators, such as those of Siemens, Wilson, and others, and from which the gases produced in the manner described (p. 369), are conveyed through culverts and gas-mains to the furnace hearth, to which they are admitted, along with the heated air necessary for their combustion, through suitable valves and ports as required for the production of the necessary furnace heat; or, instead of the producers being separated from the furnace itself, they are also made part of it, and thus replace the grate-bars of the ordinary coal furnace as in the Casson-Dormoy, the Bicheroux, the Ponsard, and the Boëtius reheating furnaces. In the last-mentioned the gases ascend from the producer direct to the fire-bridge of the furnace, where they meet with the heated air for their combustion. Reheating furnaces burning gaseous

* Mr. Snelus : *Engineer*, March 16, 1883.

fuel vary in construction with differences in the materials employed for the generation of the gas and with the mode of its combustion; thus the Bicheroux and Boëtius furnaces are without regenerators, but the air required for combustion is previously heated in the manner described (p. 280), while the waste heat of the flame as it leaves the bed of the furnace either escapes to the atmosphere or is used to raise steam by passing it beneath the steam boilers.

616. The production of gases in separate chambers or generators, with the subsequent combustion of the same by their union with the oxygen of the atmospheric air on the hearth of the furnace, was proposed and frequently tried, but without practical success, early in the present century. The subject occupied the attention of Bischoff in 1839, and from that time its further development has been in progress; but the greatest practical development and success was that obtained by Sir William Siemens with his separate gas-producer and regenerative furnace (p. 273), as now so extensively employed for reheating purposes in the forge and mill, and for the steel-melting furnaces, as well as for many other metallurgical operations where high temperatures, with great cleanliness and control over the flame, are necessary. Its adoption marks one of the greatest improvements of recent years in connection with the economy and use of fuel for furnace purposes.

617. The waste gases of the blast furnace, although providing a gaseous fuel extensively applied to the raising of steam, heating of the hot-blast, roasting of ores, burning of lime, bricks, &c., is yet too irregular in amount, and varies so much in quality according to the working of the blast furnace, that it has not been found applicable for combustion in the puddling or reheating furnace.

618. In the gas furnace the temperature is more under control, and there is a greater purity of flame upon the hearth than is possible in furnaces consuming raw coal upon the ordinary grate-bars. Further, an

oxidising, neutral, or reducing atmosphere can be maintained in the heating chamber of the furnace according as more or less atmospheric air is admitted for the combustion of the producer gases, and the loss of metal from oxidation is thereby diminished; this economy in the reheating of $1\frac{1}{4}$ -inch iron billets for the production of iron wire amounting to about 5 per cent.; for while in the gas reheating furnace the loss from oxidation does not exceed $2\frac{1}{2}$ per cent. of the metal charged, with the ordinary coal furnace the loss is nearly 7 per cent. With steel, however, the direct economy is less, since the temperatures employed are lower and the oxidation and waste are therefore less active, whether coal or gas furnaces be employed. The use of the gas furnace is also attended with a total absence of smoke.

619. The *use of the gas-producer* instead of the ordinary grate permits of the consumption of inferior classes of fuel, such as coal slack, anthracite culm, and every variety of bituminous or semi-bituminous coals, lignites, peat, air-dried wood, &c. Beyond the use of inferior fuel, the adoption of the gas-producer is attended also with a saving in the quantity of fuel consumed, besides affording a more uniform heat; and by preventing the contact of the fuel with the highly heated lining of the furnace, it obviates the destructive action of the same upon the furnace, which accordingly requires less repairs and makes more prolonged campaigns.

620. The *Siemens gas-producer* is a fire-brick chamber, A (Figs. 74, 75), rectangular in plan, and usually built below the level of the ground. The front side, *p*, of the chamber is inclined as shown from the top to the bottom, at an angle of from 45° to 60° , a usual angle being about 50° , and this slope is formed of cast-iron plates lined with fire-brick, or is built in a series of arches as shown in Fig. 74, stepped back so as to give the required slope. At the bottom of the chamber are the wrought-iron fire-bars, *s*, placed at a slight inclination from the front to the back of the

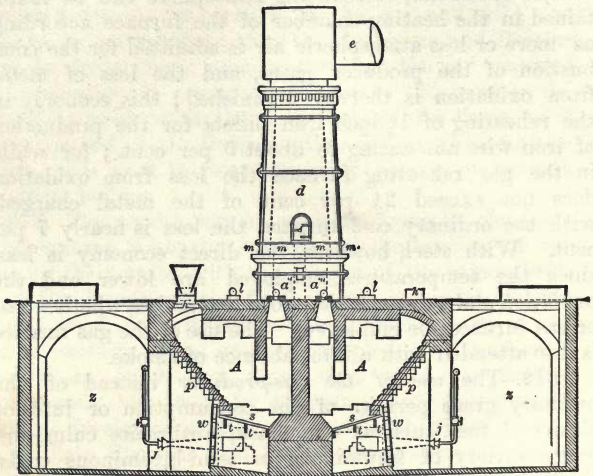

Fig. 74.—Vertical Section through Two of Siemens Gas-producers.

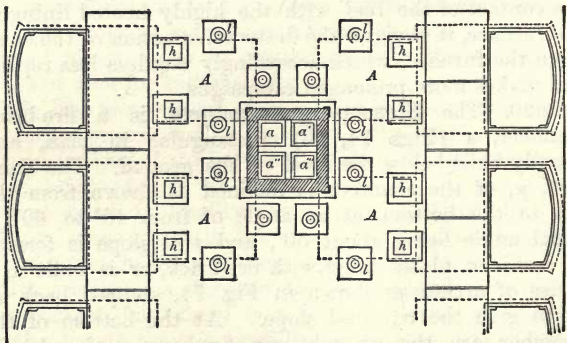

Fig. 75.—Plan at floor level of one block of Siemens Gas-producers.

chamber, and resting upon bearers, *t, t*, of cast-iron or of old rails built into the masonry. In the centre of each four chambers or block of producers is built the up-take, *d*, from 10 to 12 feet in height, which is divided up to the height of the damper, *m*, (or about 3 feet from the floor level), into four distinct flues, *a, a', a'', a'''* (Fig. 75), which open above the damper, *m*, into one common up-take; so that by inserting or withdrawing the iron damper plate, at *m*, any one of the four gas-producing chambers can be shut off or opened to the up-take without interfering with the action of the other producers of the block, when the cleaning out or repairs of any of the chambers becomes necessary. From the top of the up-take the iron cross-tube, *e*, leads to the main gas tube; or, in some works, instead of the up-take, *d*, and the cross-tube, *e*, a curved wrought-iron tube has its foot at the bottom of the up-take and curves over from thence to the main gas tube. The arched roof of the producer has several apertures built into it for pottering the fire, observing the working, and for feeding in the coal, &c., respectively; thus the *plug* or *sight-holes, l*, closed by a cap or a cast-iron ball that can be readily rolled off the aperture and replaced as required, supply a ready means of inspecting the producer as to the condition of the gas and the fire, as also for the introduction of the iron bars required for pottering down and breaking up the fire as it becomes necessary during the working. Over the aperture, *h*, is placed a sheet-iron or cast-iron hopper, with a slide or damper in the bottom between the cavity of the hopper and the producer, and this hopper is kept constantly filled with fuel, which is dropped down on to the sloping side of the producer by drawing out the slide when and as required; the charge of coal in the hopper thus serving to keep the charging aperture closed and comparatively gas-tight, whilst at the same time the coal becomes warmed and dry before its introduction into the producer; and in this manner a thick layer of coal is always kept on the

fire-bars without opening the chamber to the atmosphere during the time of charging. These producers are usually built in rows, with an arched passage or cave, *z*, along each side, through which ready access is gained to the ash-pit for the clinkering, cleaning out, and removal of the ashes; for which purpose a few of the fire-bars are withdrawn and the collected clinker broken down by the introduction of suitable bars, whilst from a flexible pipe placed opposite each producer the workman is able to cool down the clinker and ashes by delivering upon them a jet of water. A little water is also introduced into the ash-pit from time to time for evaporation by the radiated heat of the producer, and the steam therefrom, ascending over the mass of heated fuel in the body of the producer, is decomposed with the oxidation of the incandescent carbon and the liberation of hydrogen, thus increasing the volume of the combustible gases carbonic oxide and hydrogen passing from the producer. With a like object variously devised steam and air jets, *j*, have been proposed, and some form of these is now generally applied to the producers, with the view to a further economy of fuel by more perfectly consuming the coke resulting from the distillation of the coal in the upper zones of the producer, and thereby increasing, as above, the volume of carbonic oxide and of hydrogen escaping to the furnaces for combustion. Such blast-jets are introduced either below the fire-bars into the ash-pit, which is then closed by folding doors, *w*, or the blast is introduced by suitable nozzles into the body of the fuel in the producer, either from the sides, by the front, or from below.

621. A blast of atmospheric air suitably proportioned to the capacity of the producer increases alike the volume of combustible gases from the producer, the pressure of gas in the mains, and likewise their initial temperature; it also effects a more complete and larger consumption of fuel and thereby a larger volume of gas is produced by each gas-producer, thus necessitating the use of a smaller

number for the generation of the volume of gas required per furnace ; and by the application of a blast also the inferior classes of fuel are used to greater advantage. The pressure of gas within the gas mains and brick culverts leading to the furnaces is sufficient to prevent the leakage of air from the exterior to the interior of the mains through any small crevices, cracks, or other imperfections in the construction of the tubes and culverts, and the outward pressure is further increased by the use of steam or other blast at the producers. The admission of air to the gas mains, besides diluting the gas, would obviously be attended with the production of a more or less explosive mixture within the mains.

622. The producer, as thus described, has essentially the form originally introduced by Sir W. Siemens, modified only in minor details as suggested by long experience, and it is still the form most generally adopted, although Siemens, Wilson, Casson, and others have introduced circular and other producers, each of greater capacity than those above described, and fitted with variously devised atmospheric or steam blasts, but these have not to any very considerable extent superseded the original form.

623. The **Bicheroux, Casson, and Ponsard** gas producers are of the same type and are palpable copies of the Siemens producer ; but the circular producer of Messrs. **Brook and Wilson** presents features substantially differing from the original Siemens construction, inasmuch as it is a closed circular chamber (Figs. 76, 77) of brickwork within a wrought-iron casing, and into which chamber

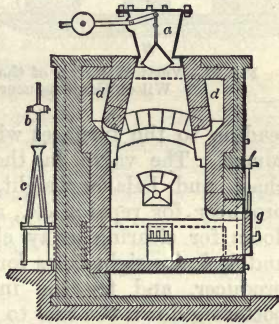

Fig. 76.—Vertical Section on line A, B, Fig. 77, of the Brook and Wilson Gas Producer.

the fuel is discharged at the top from the hopper *a*. This producer has a solid hearth without grate-bars, the blast of air for combustion being supplied into a T-shaped distributor in the centre of the hearth by a blowing arrangement, consisting of a steam jet, *b* (Fig. 76),

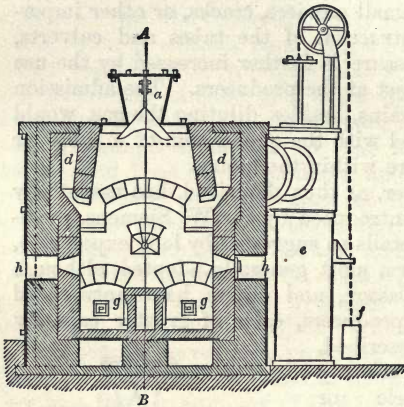

Fig. 77.—Vertical Section of the Brook and Wilson Gas Producer.

directed into a conical trumpet-mouthed nozzle, *c*, in which manner both steam and air are propelled into the centre of the producer, in the proportion of about 5 parts of the former to 100 of the latter. The gases generated in the producer make their exit by the ports *d, d*, to the downtake *e*, communicating with the gas-culvert

leading to the furnaces where the gases are to be consumed. The valve in the downtake, worked by the chain and balance-weight, *f*, serves to shut off any producer for repairs, &c., as may be required; *g, g*, are doors for clearing away clinker, &c., from the hearth; and *h, h*, are sight-holes for observing the working of the producer, and for the introduction of bars, &c., for pottering down the fuel to the hearth.

624. The action of the Wilson producer is the same as that of the Siemens producer already described. The oxygen of the atmospheric blast entering amongst the red-hot fuel at the bottom of the producer serves to support and maintain combustion, with the oxidation of the carbon to the state of carbonic anhydride (CO_2),

which gas, ascending through the superincumbent mass of incandescent carbon (fuel), is reduced by the combination of each volume of carbonic anhydride with an additional proportion of carbon, yielding thereby two volumes of combustible carbonic oxide (CO), which forms the most important and useful constituent of the escaping gases. The steam entering the producer also, if not present in excess, is wholly decomposed in passing over the incandescent fuel, with the production thereby of hydrogen and carbonic oxide, which likewise go to swell the volume of combustible gases passing from the producer; whilst the upper part of the producer simply acts as a retort for the distillation, by the sensible heat of the burning fuel below, of the volatile hydrocarbons from the fuel introduced through the hopper above, in the manner already mentioned, before the fuel descends to the more strongly heated zones below.

625. The gases produced in the Siemens, or other producer, differ considerably according to the nature of the fuel and the manner in which the producer is managed. Although, as previously stated, all classes of coal, coal-slack, anthracite culm, coke, lignite, peat, sawdust, &c., may be used alone or better in conjunction with coal, yet the best fuel for the gas producer is a *bituminous* or *semi-bituminous coal*, not too strongly caking. If the producer be worked with an open ash-pit, and without any atmospheric or steam blast, then only a limited supply of air reaches the fuel through the grate-bars, and the oxygen accordingly combines with and maintains the combustion of the lower layers of fuel upon the bars at the bottom of the producer; whilst the heat of combustion drives off or distils over the volatile constituents (consisting of hydrocarbons with other gases and vapours) from the superincumbent mass of coal. The carbonic anhydride produced at the grate-bars by the combustion of the carbon of the fuel and atmospheric oxygen, ascends through the producer over the superincumbent incandescent coke and carbonaceous matters, and is thus re-

duced to carbonic oxide, each volume of carbonic anhydride yielding two volumes of carbonic oxide—thus $\text{CO}_2 + \text{C} = 2 \text{CO}$ —which escapes from the producer to the uptake and onwards to the gas main. Thus the gases passing from the producer contain in addition to the combustible hydrocarbons and vapours previously mentioned a large proportion of carbonic oxide, diluted with a certain proportion of nitrogen from the atmosphere, and a smaller proportion of unreduced carbonic anhydride. If artificial blast be also employed then a larger proportion of carbonic oxide occurs in the gases, owing to the oxidation of a portion of the fixed carbon of the fuel by the oxygen of the blast; whilst the steam evaporated from the water in the ash-pit, as also the small quantity used in the production of the blast, ascends through the incandescent fuel, and suffers decomposition, giving up its oxygen to the carbon of the fuel and producing thereby carbonic anhydride, which is immediately again reduced to the state of carbonic oxide as above, whilst the combustible hydrogen from the water is also added to the gases from the producer: thus $\text{OH}_2 + \text{C} = \text{CO} + 2 \text{H}$. The addition of carbonic oxide and hydrogen from these sources obviously increases the calorific value of the gases.

ANALYSES OF GASES FROM THE PRODUCER.

	Using Durham coal.	Using fine coal slack.	Using a mixture of three-fourths caking with one-fourth non-caking coal.
Carbonic oxide	26.89	23.41	24.2
Marsh gas (CH_4)	1.45	2.22	2.2
Hydrogen	11.55	13.82	8.2
Nitrogen	56.11	55.86	61.2
Carbonic anhydride	4.00	4.69	4.2
	100.00	100.00	100.00
Per-centage of com- } bustible gases }	39.89	39.45	34.6

626. From the previous analyses it will be noted that the combustible or heat-producing gases, viz., carbonic oxide, carburetted hydrogen (CH_4), and hydrogen, are in the aggregate practically the same in the three examples, constituting in the first two instances nearly 40 per cent. of the total volume of the gases; whilst the nitrogen and carbonic anhydride, which constitute 60 per cent. of the volume of the producer gases, act only as diluents, and do not add (except by their sensible heat) to the heat of the furnace. The 4 or 4.5 per cent. of carbonic anhydride indicated in these analyses represents the maximum proportion of this gas at which the producer can be considered to be working well, for any appreciable excess over this figure indicates that from some cause it is working badly.

627. The Siemens regenerative gas furnace consists of three parts, viz., the *producers* or apparatus for the generation of the crude gas; the *regenerators* or chambers filled with a chequer work of fire-bricks, which alternately absorb and store up the waste heat of the flame and gases as they escape from the furnace hearth, and then subsequently give up this heat to the gases from the producers, and to the air for supporting their combustion, as each of them passes through the separate regenerators before meeting for combustion upon the bed or hearth of the furnace; and lastly, there is the *furnace structure* proper.

628. The *Siemens regenerative reheating, or mill furnace* is supported externally by iron plates, supported by stancheons, buck-staves, and tie-bolts in the usual manner and as shown in Figs. 78 and 79. The bed or hearth of the furnace is supported upon cast-iron plates kept cool by the free circulation of air beneath them, admitted through suitable holes, *p p*, left in the external plating, and the bed slopes slightly from front to back, where a tap-hole is made for tapping out the cinder or slag at required intervals. Upon the cast-iron bed plates there is first laid a course of fire-bricks

(Fig. 78), and upon this is introduced a layer of sand, B, of from 10 to 12 inches in thickness, which forms the working bottom of the furnace. The two ends of the furnace are quite symmetrically built, and are each provided usually with two ports or openings for the admission of the heated gases, and with three others for the admission of the heated air required for their combustion. The gases and air, after passing through one pair of

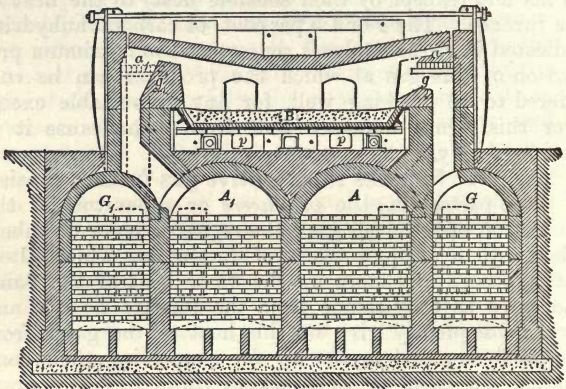

Fig. 78.—Sectional Elevation of Siemens Reheating or Mill Furnace.

heated regenerators, G, A, are admitted to the hearth at one end through the ports just mentioned, and after combustion the waste gases pass from the hearth through the ports at the opposite end, and from thence through the other pair of regenerators to the chimney. The course of the gases is reversed from one end to the other of the furnace at frequent intervals, in the manner to be immediately described. The size of hearth, as also the size and number of doors with which the furnace is fitted, depend upon the size of work to be heated. The roof of the furnace is built of the best fire-brick, is arched from side to side as shown, and slopes from the two ends

towards the centre of the hearth, whilst its height above the bed is determined by the class of work to be heated in the furnace.

629. Transversely beneath the furnace proper are built the four arched chambers, A, A₁, G, G₁ (Fig. 78) each filled with a chequer work of fire-bricks, and constituting the regenerators, of which the two smaller, G, G₁, are for heating

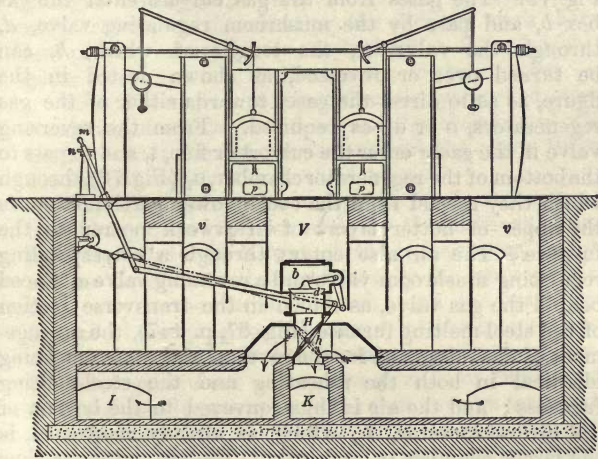

Fig. 79.—Front Elevation of Siemens Mill or Reheating Furnace, with Section through the Cave and Reversing Valve.

the producer gases, whilst the larger ones, A, A₁, perform the like function with respect to the air for their combustion. The chequer work of the regenerators is arranged in the manner shown, so as to allow of a comparatively free passage of air or gas through them, and at the same time to expose the largest possible surface for the absorption of the heat from the waste gases as they leave the furnace for the stack, or for imparting heat to the air and gases previous to their combustion upon the hearth. The admission of the producer gases and of atmospheric

air to the furnace is controlled by separate valves placed in the cave, *v*, in front of the regenerators, and below the floor level, which valves are worked by notched levers, *m*, and hand screws *n*, placed on pillars in front of the furnace, and connected by levers with the valves. The mushroom valve, *A*, (Fig. 87, p. 447) for the admission of air, is about 25 or 30 per cent. larger in area than the gas valve, *d*, Fig. 79. The gases from the gas culvert enter the gas box *b*, and pass by the mushroom regulating valve, *d*, through the valve, *H*, the tongue of which, *h*, can be turned over or reversed, as shown dotted in the figure, so as to direct the gases towards either of the gas regenerators, *G* or *G*₁, as required. From the reversing valve *H*, the gases enter the culvert or flue, *I*, and so pass to the bottom of the regenerator chamber, *G*₁, (Fig. 78), through which they ascend from the cooler lower portion towards the upper or hotter layers of brickwork nearer to the furnace. The air also enters through a corresponding regulating mushroom valve and a reversing valve *a*, placed behind the gas valve, as shown in the transverse section of the steel-melting furnace (Fig. 87, p. 447), the arrangement of the valves and for the reversal of the current being identical in both the reheating and the steel-melting furnaces; and the air is thus conveyed to the bottom of the air regenerator, *A*₁, which, as already mentioned, is the larger chamber in each pair. The air and gases thus ascend through their respective regenerators to the furnace hearth, which they enter: the first-named through three openings, *a*, *a*₁, while the gas enters by the two ports, *g*, *g*₁; by which means the air is admitted above and behind the gas as shown in Fig. 78. If the furnace be already heated, combustion of the gases at once ensues upon the meeting of the same upon the furnace hearth, producing thereby a large flame and an intense heat, proportionate to the amount of gas admitted through the regulating valve already named; whilst, as before noted, a reducing, neutral or oxidising flame can be maintained by varying the proportion of air to gas admitted to the

furnace. The air and gases are thus admitted at one end of the furnace, after having been heated in their course from the regulating valves to the furnace by passing over the heated chequer work of the pair of regenerators at the same end of the furnace; the flame and waste gases escape at the same time by the ports at the opposite end of the hearth and are drawn down by the chimney draught through the chequer work of the other pair of regenerators, A, G, reheating the chequer work therein, and passing on until they reach the flue, K, by which the gases pass, as shown by the arrows, to the chimney.

630. The regenerators are thus always worked in pairs consisting of one large and one smaller chamber, of which the air passes through the former and the gases through the latter on their way to the furnace.

631. The waste gases and products of combustion are thus always drawn downwards by the chimney draught from the top to the bottom of the regenerators, or in the reverse direction to that traversed by the gases and air on their way to the furnace hearth; and the waste gases instead of escaping to the chimney at the temperature of the furnace, give up in their passage over the chequer work of the regenerators a large proportion of their sensible heat, and finally pass away to the chimney at a temperature of only about 150° C. (302° Fahr.). In this manner the upper tiers of bricks in the regenerators may be heated to a temperature only slightly lower than that of the furnace itself, whilst the courses of brickwork lower down or farther from the furnace become successively less and less heated. While one pair of regenerators is being thus heated by the gases escaping from the furnace towards the stack, the heat stored up in the brickwork of the other pair is being absorbed by the producer gases and the air passing through them towards the furnace, until the temperature of one pair of regenerators has been sensibly or sufficiently reduced, and the temperature of the other pair at the same time proportionately raised, then the direction of the gaseous current is reversed by moving

the tongue, *h* (Fig. 79), of the reversing valve, *H*, into the position shown by the dotted lines, when the flame and waste gases are then drawn away at the opposite end of the furnace through the other pair of regenerators, which are heated in the same manner as before, whilst at the same time the gases and air are drawn upwards towards the furnace through the last heated pair of regenerators. The gases and air thus enter the regenerators at their lower or cooler end, and ascend towards the more strongly heated parts, becoming in their passage gradually heated by contact with the heated brickwork, until, when entering the furnace, the producer gases and the air have a temperature almost equal to that of the waste gases escaping from the opposite end of the furnace. The gases and air thus raised to an elevated temperature only mix upon entering the furnace hearth, when their combustion fills the same with an intensely heated flame; and were it not for the introduction at intervals of cold or comparatively cold materials into the furnace, together with a proper adjustment of the amount of gas admitted, it is obvious that, by reversing the course of the gas at regular intervals, a gradually increasing temperature would be obtained, since the heat produced by the combustion of the gases is added to that absorbed by the gases and air from the regenerators in their passage through them, so that after each reversal of the current the temperature of the regenerators and therefore of the flame would be higher than it was after the previous reversal; and the temperature ultimately attainable in the regenerative furnace is only limited by the capacity of the refractory materials of which the furnace is constructed to withstand the heat.

632. Most of the heat generated by combustion is retained in the furnace and regenerators, since the temperature of the gases escaping from the chimney under careful working of the furnace rarely much exceeds about 150° C. (302° Fahr.), whatever may be the temperature of the furnace; whilst, in the ordinary reheating furnace burn-

ing coal in its own grate-bars and without regenerators, the amount of heat carried away to the stack by the waste gases exceeds that which is utilised in doing useful work; hence the regenerators, by utilising the waste heat, effect a considerable economy in fuel over the ordinary furnace without regenerators, and this saving is greater in proportion as the working temperature is increased.

633. From 6 to 8 square feet of regenerator surface is usually calculated as being necessary to take up or absorb what is practicable of the heat generated by the combustion of 1 lb. of coal.

634. With a cold furnace, or on first lighting up a new furnace, it is necessary to dry it carefully by burning a large fire upon the hearth for some days before turning the gas into it; and after thus thoroughly drying a large fire of wood and shavings requires to be made upon the hearth, so as to fill it with flame and so ignite the gases immediately they enter the furnace before any explosive mixture of gas and air can collect within the furnace. Combustion having been thus commenced, the temperature of the furnace is gradually raised as the gaseous current is from time to time reversed; since after each reversal the gases enter with a higher initial temperature, owing to the increased temperature of the regenerators, produced as already described; but when the furnace has attained a sufficiently elevated temperature, its further working is then regulated and controlled by limiting or increasing the supply of gas and air thereto, by means of the regulating valves already mentioned, and also by the chimney damper; and the nature of the flame is also controlled by the relative proportions of air and gas respectively admitted to the furnace. The regulating and reversing valves are moved by levers, *m*, and hand screws, *n*, (Fig. 79) or by notched levers worked by the workman from the front of the furnace. The current requires reversing at intervals of from thirty to fifty minutes, according to the size of the furnace and the temperature to be maintained.

635. The **Boëtius gas reheating furnace** is without regenerators, but the air for combustion is delivered through slots in the fire-bridge, and also from a broad flat opening, situated above and behind the aperture for the admission of gas from the producer to the hearth of the furnace. The air for combustion is heated before its admission by being circulated through a series of flues in the casing walls and roof of the producer, of which the inner walls are purposely built only $4\frac{1}{2}$ inches in thickness, so as to transmit the heat of the producer freely to the flues through which the air for maintaining the combustion of the gases is drawn. The *producer* is a deep rectangular chamber with one sloping side and an inclined grate at the bottom, resembling the Siemens producer already described, but it is built as a portion of the furnace itself and thus replaces the grate-bars of the ordinary coal furnace. The producer is closed by an arched roof, in which there is an opening for the introduction of the fuel, and the producer gases pass to the furnace hearth through a long narrow slot, situated above the fire-bridge. The producer gases and heated air thus meet at the fire-bridge and produce a large volume of flame, which plays over the hearth and fills the body of the furnace, whilst the heated gases, the products of combustion, &c., escape by the flue at the other end of the hearth, and are either used in the raising of steam, &c., or are allowed to escape directly to the chimney, according to the arrangement of the furnace. This furnace is said to save from 15 to 20 per cent. of the fuel required for the ordinary coal-burning reheating furnace.

636. The **Bicheroux reheating furnace**, like that last described, consists of a furnace, *a*, and gas-producer, *b*, in one structure, (Figs. 80, 81,) which is unprovided with any regenerative apparatus, but heats only the air required for the combustion of the producer gases. The air is heated by circulating it through a broad flat flue of from 25 to 30 feet in length, and of almost the full width of the

furnace hearth beneath which it is built, whereby a large heating surface is presented to the air as it passes to the fire-bridge to meet the producer gases ; by this means a high initial temperature of gases and air, though in this respect inferior to that attainable with the Siemens

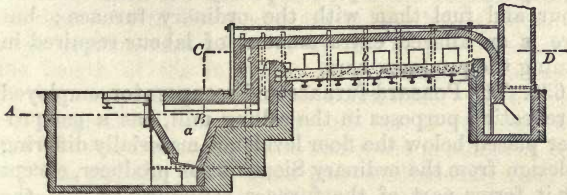

Fig. 80.—Sectional Elevation of the Bicheroux Reheating Furnace.

regenerators, is obtained before combustion takes place, and thus a high temperature is readily produced on the furnace hearth. This furnace is somewhat largely employed in steel works for the reheating of steel ingots for the rolling mills, in which process it consumes about

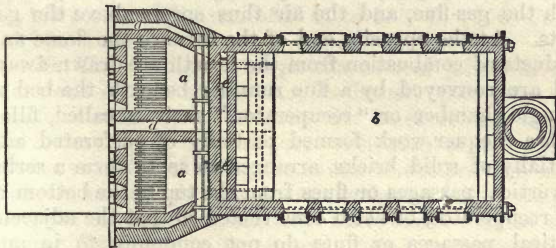

Fig. 81.—Plan of the Bicheroux Reheating Furnace, on the line A B C D. (Fig. 80.)

2½ cwts. of small coal per ton of ingots heated, and with Casson's modification in the gas-producer, constituting the *Casson-Bicheroux* furnace, it is finding its way into some of the principal iron works of Staffordshire and elsewhere. Fig. 81 shows the method of heating the air by circulat-

ing it through the hollow sides, *d, d*, of the gas producer, before it enters the furnace from the long slot, *e, e*, behind the gasports, *f*.

637. The **Casson-Bicheroux furnace** has also been adopted as a puddling furnace, and is reported to afford larger yields and a superior quality of iron with less labour and fuel than with the ordinary furnace; but there is an alleged extra amount of labour required in cleaning the producer bars.

638. The **Ponsard furnace and recuperator**, employed for reheating purposes in the rolling mill, has a gas producer placed below the floor level, not materially differing in design from the ordinary Siemens gas producer, except that it forms part of the furnace structure, so that the gases pass for combustion direct from the producer chamber to the fire-bridge of the furnace. The supply of gas from the producer to the furnace is controlled only by a damper inserted in the throat of the producer, between it and the bridge of the furnace; while the air for combustion is conveyed from the recuperator or regenerator to the fire-bridge by a flue passing behind and parallel with the gas-flue, and the air thus enters above the gas ports. At the opposite end of the furnace the flame and products of combustion from the hearth are drawn away, and are conveyed by a flue running beneath the bed to a single chamber or "recuperator," as it is called, filled with a chequer work formed partially of perforated and partially of solid bricks, arranged so as to form a series of vertical passages or flues from the top to the bottom of the recuperator, but also constructed so that the adjacent vertical passages or flues do not communicate in any manner with each other, while the alternate vertical passages do so communicate with each other through horizontal perforations or holes in the bricks themselves. Thus the circulation of the air proceeds in a transverse as well as in a vertical direction, as it ascends from the bottom to the top of the recuperator and thence to the bridge of the furnace. This form of recuperator thus

necessitates the use of two kinds of fire-bricks in its construction, viz., the hollow or perforated bricks above-mentioned, which are laid transversely across the chamber, and by which the several air flues communicate the one with the other; while the other bricks, forming the flues through which the waste gases from the furnace descend on their way to the stack, are oblong bricks, square in cross section, and laid end to end in the direction of the length of the furnace. In this manner the action of the recuperator is made continuous, there being no reversal of the current such as is required with the Siemens furnace, but the flame, the products of combustion, and the waste gases pass continuously from the same end of the furnace through one set of vertical flues or passages from the top to the bottom of the recuperator, while the cold air for supporting combustion is admitted by a valve at the bottom of the recuperator chamber, and ascends through the other set of vertical flues, the brick sides of which are heated by the waste gases circulating around them in the adjacent flues. The air then enters the furnace, after traversing the recuperator, at a temperature of from 482° C. to 538° C. (900° Fahr. to 1,000° Fahr.).

639. The leakage through the several joints in the brickwork of the recuperator is largely prevented by forming shallow grooves along the faces of the bricks where they come into contact with each other, which grooves are filled with mortar as the bricks are laid, and, since the mortar expands under the heat of the recuperator, the several flues are kept fairly tight. Since the pressure of air ascending through the air passages of the recuperator is always slightly in excess of that of the waste gases descending in the other passages, it hence follows that any leakage from bad joints, cracks, &c., would be mostly from the air to the waste-gas passages, and the only effect would be to more completely consume the gases from the furnace, with a proportionate addition thereby of heat to the recuperator.

640. In Austria and Hungary, a gas furnace using wood for its fuel has been arranged with three hearths between the gas generator or producer and the stack, thus combining a reheating and puddling furnace in one structure. The first hearth close to the producer constitutes a reheating hearth, and is heated only by the sensible heat of the gases from the producer, whilst on the second or puddling hearth the maximum heat is obtained, the producer gases being there burnt by the admission over the fire-bridge of the air necessary for their combustion; and the third hearth, situated nearest to the stack, is employed in heating the charge of pig-iron before its introduction on to the middle or puddling hearth, the requisite heat being afforded by the waste-gases from the puddling hearth on their way to the stack.

641. By the use of the so-called "soaking pits" Mr. Gjers* has shown that it is easy to roll a bloom, rail, or other finished *steel* bar from a suitable steel ingot without the expenditure of any fuel for reheating, the initial heat of the ingot, together with the store of latent heat in the fluid steel which is given out during its solidification, being more than enough for the requirements of the hammering or rolling processes.

642. Steel ingots, when newly stripped—that is, withdrawn from the moulds in which they have been cast—are far too hot in the interior for immediate rolling, and if allowed to stand in the open until the interior has cooled down sufficiently, it is then found that the exterior has become much too cold to roll satisfactorily. Hence the soaking arrangement is intended to provide for the uniform distribution throughout the ingot of the excess of heat stored up by the fluid metal in the interior, whereby a uniform and sufficiently high temperature is obtained to enable the ingot to be easily rolled in the blooming or cogging mill and afterwards passed through the finishing rolls.

643. The *soaking pits* consist of a number of vertical

* Iron and Steel Institute, 1882.

pits built together in a mass of brickwork below the level of the floor, each pit being about 3 inches wider across the mouth than the ingots it is intended to accommodate, so as to allow space for the fins of metal, &c., often hanging to the bottoms or tops of the ingots. The pits are also built from 6 to 18 inches deeper than the length of the ingot, and they should be lined with very heavy fire-bricks to withstand heavy wear and the blows of falling ingots. A separate lid or cover is applied to each of the pits to exclude atmospheric air, and the whole is served by an ingot crane, which lifts the ingots from the pits and delivers them at the blooming rolls. Before using the soaking arrangement it is necessary to first well dry the brickwork, and then to heat it to redness by placing hot ingots within the pits, after which the apparatus is ready for work. As soon as the ingots are stripped in the casting pit, they are lifted out at once and placed by the crane into the previously-heated soaking pits, where they are covered by the lids above mentioned, and there allowed to remain during from twenty to thirty minutes or upwards according to the size of the ingot; after this interval the excessive heat of the molten metal in the interior, with the latent heat which has become sensible during solidification, becomes more evenly distributed throughout the mass, whereby the metal presents a fairly uniform temperature throughout, with a surface heat in excess of that presented by the ingot on its first introduction into the pit, and altogether the metal is sufficiently hot for treatment in the rolls or under the hammer. Comparatively little heat escapes during the process of soaking, since the ingot is surrounded by a mass of brickwork, which is heated by the surplus heat of the ingots successively introduced into the pits to a temperature almost equal to that of the ingots themselves.

644. During the soaking a quantity of gas exudes from the metal and fills the pits with a non-oxidising atmosphere of hydrogen, nitrogen, carbonic oxide, and

carbonic anhydride, to the exclusion of atmospheric air, and the loss of metal by oxidation is therefore avoided. The above gases are seen escaping slightly around the covers of the pits during the soaking operation, and when the covers are lifted combustion of the enclosed gases at once ensues.

CHAPTER XVII.

STEEL AND INGOT IRON.

645. STEEL is essentially a compound of pure iron with small per-centages, ranging usually from 0.1 to 1.25 per cent. of carbon, existing, not as graphite, but either as combined or dissolved carbon, the latter view now receiving influential support. All other elements, although several are invariably present in greater or less proportion, must still be regarded as impurities in the steel, notwithstanding that it may be advantageous to introduce some of them to impart special qualities to the metal, or to neutralise the effect of the presence of others of them.

ANALYSES OF STEEL.

	Soft Neuberger Bessemer steel.	Soft Siemens Martin steel.	Siemens steel plates.	Bessemer steel rails.	Siemens steel rails.	Crucible steel for forgings.	Bessemer steel rails.	Hard Bessemer steel.	Hard tool steel.
Carbon . . .	·126	·167	·21	·352	·370	·36	·313	·687	1·144
Silicon . . .	·135	·023	·047	·053	·040	·02	·078	·046	·166
Sulphur . . .	·014	·013	·052	·055	·042	·02	·076	·008	—
Phosphorus . .	·060	·062	·035	·061	·033	·03	·071	·036	—
Manganese . . .	·158	·044	·36	·384	·342	·30	·515	·404	·104
Copper . . .	·112	·076	—	trace	·008	trace	trace	·119	—

646. Fremy* (1861) considered *nitrogen* to be a necessary constituent of steel; but nitrogen also occurs in both

* *Comptes Rendus*, Vol. LII.

wrought and cast-iron, Bussengal finding $\cdot 00057$ per cent. and $\cdot 00022$ per cent. of nitrogen in cast-steels, whilst $\cdot 00124$ per cent. was detected in wrought-iron, and $\cdot 00007$ per cent. in cast-iron.*

647. The difficulties of satisfactorily defining "steel" have already been spoken of in describing malleable iron (p. 202); and so whilst Percy, Karsten, Wedding, Tunner, Grüner, and others substantially agree in considering steel as an alloy of iron with a small per-centage of carbon, but possessing the property of being hardened and tempered, Jordon, Gautier, Greiner, Phillipart, Holley, &c., take a wider definition, and comprehend under the term "steel" all alloys of iron and carbon which have been *cast into malleable masses*. Sir William Siemens has described mild steel as a metal containing 99.75 per cent. of iron, with only $\cdot 25$ per cent. of other elements, as carbon, manganese, and the smallest possible quantity of sulphur and phosphorus; whereas the wrought-iron of commerce contains 96 to 97 per cent. of iron, with a residue for the most part of interspersed slag. Sir Joseph Whitworth endeavours to distinguish between iron and steel by the use of a numerical co-efficient, representing the sum of the tensile strength of the alloy in tons per square inch of section, and the figure representing the per-centage of its elongation before fracture in a standard length of test-piece.† But throughout these chapters under the terms "steel or ingot iron" will be embraced all combinations of iron and carbon, either with or without small proportions of other elements as sulphur, silicon, phosphorus, manganese, &c., which are malleable and permit of being hardened and tempered; and the terms will also include all such combinations of the above-named elements as are delivered from furnaces, crucibles, or other vessels in a *state of fusion*, and are at once *cast into malleable ingots*. This definition obviously excludes cast-iron, since, although the latter is delivered

* *Comptes Rendus*, Vol. LIII. † Sir J. Whitworth: "Guns and Steel."

from the furnace in a state of fusion, it always yields an ingot of pig-iron notable for its want of malleability; whilst wrought-iron, although malleable, is obtained from the furnace in a pasty, or at most a semi-fused, condition. The quality of hardening and tempering by heating and then rapidly cooling, as by immersion of the heated metal in cold water, was long considered to be a distinguishing quality of steel, but this view is no longer tenable, since the very soft steels now producible are not sensibly hardened by this treatment.

648. Steel has a *bluish-grey colour*, and in cast-steel it is usual to consider the quality better according as the blue tinge is more decided, but after hardening the metal is whiter than in the soft state. The appearance of the *fracture of steel* varies with its hardness and manner of breaking: thus in the harder tempers it is brilliant, shining, silky, fine, and distinctly but uniformly crystalline or granular, the crystalline faces often ranging themselves in lines perpendicular to the sides of the ingot; while the softer tempers of steel are bright, though not quite so lustrous as the harder tempers, and the crystalline faces are larger, approaching more to a fibrous structure; but the metal should not present the appearance of bright specks embedded in a dull matrix, nor yet present a uniformly dull and leaden appearance. The fracture, however, whilst affording to the practised eye a ready indication of the temper and quality of the metal, also varies much according to the manner in which the sample has been broken. Thus mild steel, when broken by a sudden jerk yields crystalline surfaces; while if the breaking stress be progressively augmented until fracture occurs, then there is a tendency to develop a fibrous appearance in the fracture. Steel ingots are usually more or less *unsound, honeycombed, vesicular, or piped*, which structure is not always apparent, however, after reheating and hammering or rolling. The *specific gravity* of steel varies between 7.62 and 7.91, and is lower in its hardened than in its soft state. *Wire-*

drawing and *cold rolling* although increasing the tenacity of the steel also lower its specific gravity, since under these treatments the metal elongates more rapidly than the cross section diminishes, and hence the lower density.

SPECIFIC GRAVITY OF STEEL.

Per-centage of carbon.	Specific gravity in soft state.	Specific gravity after hardening in water.
0.4	7.893	7.839
0.54	7.85	—
0.9	7.87	7.808
1.5	7.785	7.736

649. Steel is very *malleable* and *forgeable* when heated, but it is usual to work it at a somewhat lower temperature than is practised with wrought-iron, and with all except the mildest (softest) tempers it requires a little more care and experience for its manipulation. But the soft qualities can also be *welded* almost as easily as wrought-iron, although requiring a somewhat less elevated temperature. It may be noted that the large front plates of marine and other boilers, as also their longitudinal flues and cross-tubes, are now frequently so welded, without any special precautions being observed (see *Welding*, p. 7). Steel has a lower *co-efficient of expansion* for heat than cast-iron, and hence the moulds prepared for steel castings have a little less allowed for shrinkage than is required for cast-iron. The average *melting point* of steel is considered to be about 1,800° C. (3,272° Fahr.), but this varies widely with the content of carbon and the presence of other elements in the metal. Steel is less easily *magnetised* than wrought-iron, but the magnetism is more permanent, and if alloyed with tungsten it retains its magnetism in a remarkable degree.

650. The *corrosion* or *oxidation* of steel by exposure to the combined action of air and moisture appears to be somewhat less than occurs with wrought-iron under like conditions, although this, like the other qualities of steel,

varies much with the composition of the metal. The experiments of Mallet, Phillips, and others seem to show that the more nearly either iron or steel approaches to the pure alloy of iron and carbon the more affected by air and moisture; so that, by selecting iron or steel according to its chemical composition, it is possible to show that either the one or the other resists the corrosive action better than the other, according to the desire of the experimenter. The presence of *tungsten* in steel is said to render it less oxidisable by exposure to ordinary atmospheric conditions, whilst *chromium* acts exactly in the reverse manner. *Manganiferous steel* is also more corroded by sea-water than the less manganiferous metal. *Pickling*, or immersion of the steel plates in dilute sulphuric acid so as to clean the surface from adhering scale, is said to diminish the corrosive effect of exposure to the action of sea-water, or of air and moisture; since the scale or magnetic oxide of iron on the surface of the plate is electrically negative towards steel, and it hence follows that wherever exposure of the clean surface of the plate occurs in juxtaposition to a scale-covered surface, there corrosion is likely to result. To prevent corrosion, therefore, either regular painting, the use of galvanised plates, or the adoption of such preliminary treatment as that of Mr. Barff is necessary. *Barff's process* consists in exposing the surface of the metal to be protected at a red heat to the action of superheated steam, and thereby coating the surface with a thin, but continuous, closely adherent, and permanent covering of magnetic oxide of iron.

651. A characteristic and important quality of the *harder tempers* of steel—that is, such as contain from 0·4 to 0·5 per cent. or upwards of carbon, and more especially of the class of metal required for the production of the various edge or cutting tools, &c.—is that of *hardening* and *tempering*, whereby, if the metal be heated to redness, and then plunged while still hot into water, oil, or other medium by which it is rapidly cooled, the

steel acquires great hardness. The hardness so attainable increases with the proportion of the carbon in the steel, as also with the rapidity with which the cooling is effected; hence thin light sections, permitting of a more rapid cooling, can be made harder than the heavier and thicker masses; also, the more highly carburised is the steel the lower is the temperature at which the hardening can be effected, while pure iron cannot be hardened by this treatment, and mild or soft steel ($\cdot 15$ per cent. of carbon) is only very slightly toughened by it. The *degree of hardness* produced depends also upon the difference in temperature between the steel and the hardening or cooling fluid, as also upon the quantity of the cooling fluid, its power of conducting heat, its specific heat, its boiling point, and heat of vaporisation: hence mercury, water, and oil are in descending order of their power to harden steel. The harder tempers of tool steel, or such as contain 1 per cent. or upwards of carbon, can be made in this manner sufficiently hard to scratch glass, but the hardened metal has suffered thereby a considerable loss in its ductility. Steel containing 0.25 per cent. of carbon is perceptibly hardened or toughened by heating and sudden cooling, but it is only with steels containing 0.5 per cent. or upwards of carbon, influenced also by the presence of other elements, that the hardening quality is sufficient for the requirements of tools, chisels, and the like. The specific gravity of the metal in its hardened state is, as already indicated (p. 387), slightly lower than that of the unhardened metal; but by again heating the steel to redness after hardening and allowing it to cool down gradually the original malleability, softness, and specific gravity are restored.

652. The "tempering," or "letting-down," of the metal from the state of extreme hardness and brittleness produced by sudden cooling, is effected (so as to afford the different degrees of hardness required to suit the varied purposes to which the hardened metal is to be applied) by carefully reheating the hardened steel to a

lower temperature than that employed in the hardening process, and at the same time it is usual to expose a polished surface of the metal to the action of the atmosphere, when the colours that successively appear upon the surface under these conditions indicate to the workman the temperature which the metal has attained, and the degree of hardness still remaining in the steel, so that when the desired colour appears the article is finally again cooled down in water, and is ready for use. If the hardening be too strong, the steel breaks or cracks to pieces either during the process of hardening or in a short time afterwards, and this tendency to crack is increased as the proportion of carbon increases; and a large proportion of manganese is also apt to have the same effect. Another object of the tempering, or letting-down process, is to prevent the hardening being so strong as to lead to the fracture of the steel. By the gradual heating in the tempering process the steel becomes softer as the temperature rises; thus the lowest temperature employed for tempering is about 220° C., which affords a very high temper, suitable for surgical instruments, &c., requiring a very fine cutting edge, and it is indicated by the appearance of a *faint yellow* colour upon the polished surface of the article; rising to 230° C., the colour changes to a *faint or light-straw* tint; while at about 245° C. the polished surface presents a *full yellow*, or dark-straw colour, indicating a temper suitable for penknives, wood-cutting tools, taps, dies, and the like; with a further increase of 10° C. a temper suitable for chisels, shears, &c., indicated by a *brownish-yellow* tint, is attained, the *brown* colour reached at a temperature of about 265° C. being used for axes, plane-irons, chipping chisels, &c., while table-knives are still softer, and are reheated for tempering to the temperature of about 275° C., indicated by a *purple* colour; at a temperature of 295° C. a *full blue* colour appears on the polished surface of the steel, and at from 315° C. to 320° C. the *dark-blue* colour seen in large saws is produced; at which temper the metal has been so far softened as

to permit of a little hammering or bending in small articles without any fracture taking place. The hardening and tempering, as just described, are performed upon articles made in steel after they have been forged and otherwise finished. The operation of "annealing" or heating of steel to a red heat, with subsequent slow cooling of it, not in contact with the air, in the manner practised upon steel castings, forgings, and the like, produces in such masses a uniform softness of the metal not otherwise always attainable, and differs from tempering in being effected at a much higher temperature, and out of contact with the atmosphere.

653. If *oil* be used instead of water as the cooling medium in the hardening of steel, then the cooling is less rapid, and the steel so oil-hardened or oil-tempered becomes tougher, has a higher elastic limit and greater tensile strength than the original steel, and does not acquire the extreme hardness attending the use of water.

EFFECT OF OIL-HARDENING UPON STEEL.*

Per-centage of carbon in the steel.	Elastic limit in the soft state.	Elastic limit after oil-hardening.	Tensile strength in soft state.	Tensile strength after oil-hardening.
0·1	13·5 tons	24 tons	23·3 tons	28·6 tons
0·4	14·00 tons	28 tons	32·5 tons	43·0 tons

654. Steel, like iron, if too strongly heated, becomes friable or granular and unweldable: a condition in which the metal is described as being "burnt," which injury is variously assigned to the escape from the steel of some volatile substance, as hydrogen, to the loss of carbon, or, as is more probable, simply to a molecular change resulting in the production of a friable, unworkable mass. This change is produced at a somewhat lower temperature with steel than with iron, whilst the more phosphorus is contained in the metal the stronger is the tendency to be spoiled by over-heating.

* Sir W. Armstrong: British Association, 1882.

655. Steel appears to have the power of *occluding* certain gases, such as hydrogen, nitrogen, carbonic oxide, &c., and ingots of the metal often present an unsound fracture, the unsoundness being either in the form of a honeycombed structure, as presented in mild steel, or of a central funnel-shaped hollow or pipe running along the centre of the ingot, if the steel be of a harder temper; but with ingots of medium temper, containing about 0·5 per cent. of carbon, dead melting and careful teeming (pouring) to a great degree obviate the unsoundness in small ingots; yet, with larger ingots produced from the Bessemer Converter, or the Siemens open-hearth furnace, unsoundness of the upper portion of the ingots (Fig. 95, p. 507) is invariable, especially with mild steel of 0·2 per cent. or under of carbon. The gases thus separated from the metal as it cools from fusion, and which fill the cells of the unsound ingot, consist of from 70 to 90 per cent. of hydrogen, with from 10 to 20 per cent. of nitrogen, as indicated in the following analyses. The addition of silicon, as described (p. 507), does much to remove this unsoundness in such steel ingots as permit of the use of 0·2 per cent. of silicon without rendering the steel too hard and brittle for the purposes to which it is to be applied.

COMPOSITION OF THE GASES FROM THE CAVITIES OF UNSOUND STEEL INGOTS.

	Steel containing C=0·42%, Si=1·00%, Mn=1·08% (Stead).*	Steel containing C=0·33%, Si=0·1%, Mn=0·69% (Stead).	Steel containing C=0·17%, Si=0·09%, Mn=0·89% (Stead).	Bessemer steel (Muller).†	Open hearth steel (Muller).†
Hydrogen .	67·10	86·62	87·21	77	67·8
Nitrogen .	30·30	13·29	11·15	22·9	30·8
Carbonic oxide	2·60	0·32	1·64	—	2·2
Oxygen .	—	0·37	—	—	—

* "Proceedings of the Cleveland Institute of Engineers."

† "Berichte der Deutschen Chemische Gesellschaft."

656. The wavy or water-line figuration and brown colour presented by the surface of certain polished steel goods, such as the celebrated Damascus sword-blades, the barrels of small arms, &c., and known as "Damaskeening," is the result of the treatment of the articles, under suitable conditions, with weak acids, during which the several parts of the articles are unequally affected by the solvent or corrosive action of the acids, whereby the harder or more highly carburised portions are coated with a thin film of carbon, producing a dark-brown appearance, while the softer portions remain almost bright. The effect is increased by purposely forming such articles from compound bars, made by doubling up and welding together bars of iron and steel, which are then treated with the acids as before, yielding accordingly a more strongly-marked figuration.

657. *Phosphorus* hardens steel more rapidly than carbon does; it also increases its rigidity, but sensibly impairs the power of the steel to resist impact, so that the metal containing very sensible proportions of phosphorus is only workable when the carbon is kept very low, as by the use of ferromanganese in the manufacture of the steel, by which means sufficient manganese can be introduced to neutralise the effects of the impurities without adding an excess of carbon. Small proportions of phosphorus suffice to render steel "cold-short," although such metal may be hammered or rolled at a suitable temperature; and accordingly it is frequently stipulated, as in rail specifications, that the phosphorus shall not exceed 0.1 per cent., while the usual proportion in good qualities of mild steel is from 0.016 to 0.04 per cent. only; but the commoner qualities of iron often contain 0.2 per cent., and better classes 0.075 to 0.14 per cent.

658. *Sulphur*, like phosphorus, has, when present in but very small quantities, a very marked influence upon the working qualities of steel, but, unlike phosphorus, it produces a metal which may be worked when cold,

but which is brittle and unworkable at temperatures at or above redness, constituting the metal "red-short." The presence of but 0.05 per cent. or upwards of sulphur in steel produces a metal which is sensibly red-short; but 0.01 per cent. of sulphur may be considered to be harmless.

659. *Silicon* in small proportions increases the hardness of steel, in which respect it appears to stand intermediate between phosphorus and carbon. The presence of 0.5 per cent. of this element yields a metal which is "red-short," or unworkable at a red-heat; but silicon has of late been somewhat extensively used as an antidote or preventative for the unsound or honeycombed structure of steel ingots. M. Pourcel, at the Terre Noire Co., has produced steel castings of considerable solidity and uniformity, by the addition in suitable proportions of a specially prepared pig-iron especially rich in silicon and manganese, such pig containing about 2.18 per cent. of combined carbon, 18.25 per cent. of manganese, and 10.82 per cent. of silicon. This siliceous pig is added to the molten metal, in lieu of a portion of the spiegeleisen or ferromanganese ordinarily added, when the resulting silicon steel will contain from 0.2 to 0.3 per cent. of silicon; and though such steel is largely employed in the production of steel castings, it is generally too hard and unreliable for most of the structural purposes to which mild steel is applied.

ANALYSES OF SILICON STEEL.

Carbon	0.39	0.459	0.287
Sulphur	0.05	trace	trace
Silicon	0.29	0.221	0.233
Phosphorus . .	0.10	0.078	0.076
Manganese . . .	0.83	0.670	0.693

660. *Manganese* is a usual constituent of steel to the extent of from 0.25 to 1 per cent., and its presence acts like that of carbon in increasing the elastic limit and ultimate tensile strength of the metal, but it diminishes

its ductility, and if in excess it unduly hardens the steel and at the same time increases the fineness of the crystalline fracture of the metal. In a limited degree manganese neutralises the cold-shortness produced by phosphorus, when the latter element does not exceed 0·25 per cent. ; and 0·5 per cent., or a little over, of manganese also improves the working qualities of soft steel, otherwise "red-short" from the presence of sulphur ; but it is doubtful whether manganese is a desirable constituent in either steel or iron that is practically free from such impurities as phosphorus, silicon, sulphur, and oxygen, while it is indispensable in such metal as is rendered inferior by the presence of the above-named elements. When steel scrap is melted and cast into ingots, without the addition of manganese or spiegel-eisen, the metal so produced is invariably more or less red-short and wanting in body ; but if a small quantity of manganese be introduced into the charge in some form, such red-shortness is obviated ; and the addition of manganese is especially necessary in steel produced by any oxidising process. The metal from the Siemens open-hearth process, when made from Swedish pig void of manganese, with puddled bar produced from best hæmatite pig-iron, but also free from manganese, will break into pieces at the first blow of the hammer ;* whilst similar metal, but containing 0·08 per cent. of manganese, will forge readily. An excess of manganese in steel is generally believed to produce a metal more subject to corrosion by sea-water than is less manganiferous steel.

661. *Alloys of manganese* with carbon and iron, with smaller proportions of other elements, constituting either spiegeleisen or ferromanganese according to the per-centage of manganese present in the alloy, are necessary for the successful conduct of the steel manufacture either by the Crucible, the Bessemer, or the Siemens process.

662. *Tungsten* may be alloyed with steel in various proportions, yielding when the tungsten does not amount

* Willis : Iron and Steel Institute.

to more than 3 per cent., very hard, ductile, and tough alloys. The so-called "tungsten steels" contain usually from 1 to 3 per cent. of tungsten, but when more than this amount is present the metal becomes exceedingly hard and unforgeable, but can be cast into the form of tools for the engineer's use, which can be ground to a fine edge, and are of sufficient hardness to permit of use without the usual hardening or tempering by heating and cooling in water, as practised with the ordinary tool steel; such tools often possess great endurance, and contain occasionally as much as 10 per cent. of tungsten. Steel containing 0·8 per cent. of carbon and 3 per cent. of tungsten can be worked like ordinary tool steel of this temper, but, after hardening and magnetising, it will retain its magnetism to a remarkable degree. The presence of tungsten gives to the steel a very fine and uniform crystalline fracture, and such steel is less oxidisable by exposure to atmospheric influences than is the ordinary metal.

663. *Chromium* yields alloys with steel possessing great hardness, strength, and malleability, but such metal is reported to be more affected by exposure to air and moisture than the ordinary steel.

664. *Titanium*, though often occurring as a constituent of grey pig-irons, does not appear to readily alloy itself with steel; for, although titanic steels have been prepared with more especial application to the improvement of such hard steel as requires to be repeatedly reheated and rehardened, the efficiency of titanium is questionable, and the author has failed to detect it in some specimens of the so-called titanic steel.

665. *Copper* is productive of red-shortness in steel; about 0·3 per cent. yielding with mild steel a metal which cracks at the edges; but 0·1 per cent. of copper is without appreciable effect.

666. *Gold, platinum, and aluminum* alloy with steel, but the products so obtained are without practical application in the arts (see p. 60, under Iron).

667. *Tin* yields alloys with steel which are red-short and unweldable, proportions not exceeding 0·15 per cent. of tin being productive of these deteriorating qualities.

668. The ultimate tenacity, or tensile strength, as also the *elasticity* and *rigidity* of steel, appear to vary directly with the temper as affected principally by the proportion of carbon present in the steel, but the proportions of phosphorus, silicon, manganese, tungsten, chromium, &c., also affect these qualities in the manner already described; further, hammering, rolling, wire-drawing at suitable temperatures, tempering, or other mechanical treatment, also increases the tensile strength as well as the ductility of the metal. Thus a piece of metal cut from an ingot gave a test-piece breaking under a tensile stress of 23·6 tons per square inch of section, and elongating only 10 per cent. in a length of 8 inches; but by hammering the piece down to one-fourth its original section its tensile strength was raised to 32 tons per square inch, the elongation at the same time increasing to 11 per cent.; or by rolling to one-fifth of the original section the tensile strength became equal to 30 tons to the square inch, affording at the same time an elongation of 23 per cent. upon an 8-inch test-piece; and further plates rolled from the same charge to $\frac{7}{8}$ -inch in thickness had a tensile strength of 27 tons to the square inch, and the test-piece of 8 inches elongated 26 per cent. of its length before fracturing. The enormous increase in the tensile strength of iron effected by wire-drawing has been already described, and no steel is comparable with respect to strength and toughness to that which has been drawn into the form of wire or into riband, the highest strength being attained in passing the steel through a die as in the final stage of wire-drawing, whereby a hard skin is put upon the wire, which adds greatly to its strength but is unfavourable to its bending qualities.

669. *Mild steel* containing from 0·05 to 0·20 per cent. of carbon will weld, but does not temper, and will usually

break under a tensile stress of from 23 to 32 tons per square inch of section, elongating before fracture occurs from 25 to 30 per cent. of its length in a test-piece of 8 inches in length, and such metal is employed for boilers and ships' plates, nails, wire, rivets, &c. A temper corresponding to from 0·20 to 0·35 per cent. of carbon yields a metal suitable for axles, ordnance, rails, &c., which will harden a little by quenching in cold water, and which is scarcely weldable. This metal will have a tensile strength of from 30 to 38 tons to the square inch, elongating in the 8-inch test-piece from 20 to 25 per cent. of its length. A still harder temper, available also for rails, tyres, springs, hammers, &c., contains from 0·35 to 0·5 per cent. of carbon; it has a tensile strength of from 38 to 45 tons per square inch, with an elongation of from 15 to 20 per cent.; but such metal cannot be welded, and will become decidedly hard by quenching in cold water. With 0·5 per cent. and upwards of carbon metal suitable for files, saws, taps, and tools generally is produced; such steel is unweldable, tempers strongly, has a tensile strength of 45 tons and upwards to the square inch, with a proportionate decrease in the elongation or extension before fracture. The steel required for engineers' tools and the like, has frequently a tensile strength of 60, 70, or 80 tons to the square inch without having received any special mechanical treatment, but after wire-drawing such metals will attain to 100 or 120 tons of tensile strength; and, as already shown, the strength, ductility, and toughness of mild steel is very considerably affected by the degree of hammering and rolling which it has received. As already noted, the introduction of phosphorus, silicon, manganese, &c., beyond the usual amounts, will harden the metal, and so vitiate, if they be present in excess, the above general statements as to the strength, &c., of steel. The tensile strength of the metal is not alone a sufficient test of the quality of the steel, and hence, where the metal is required for structural work, as for boilers, bridges, ships' plates, rails, tyres,

axles, shafts, &c., it is usual to submit it to certain prescribed hot and cold forge-tests (p. 6), to tempering, and to the impact of falling weights; the last-mentioned being more particularly applied to the testing of rails, tyres, and axles; the weight for rail-testing being a tup or monkey of 1 ton in weight allowed to fall from a height of from 15 to 20 feet, according to the section of the rail under trial, upon the rail supported on bearings 3 feet 6 inches apart. (*See* p. 401).

670. The *elongation* of the milder qualities of steel before fracture occurs is superior to that of malleable iron. Thus the mild steel before referred to as containing 0·1 per cent. of carbon will elongate over a length of 2 inches to the extent of $37\frac{1}{2}$ per cent. of its original length, likewise the steel having a tensile strength of about 30 tons to the square inch, will elongate 26 or 28 per cent. of its length over a test-piece of 8 inches in length.

671. The British Admiralty specify that the mild steel used by the Government for ship-building purposes shall have a tensile strength of not less than 26 tons or more than 30 tons to the square inch of section, against 22 tons required in iron (p. 208), and that the steel shall stretch 20 per cent. of its length in a test-piece 8 inches long before fracture occurs; and in plates the test-pieces are to be cut both across and along the length of the plate. Lloyds' surveyors require for the same purposes a tensile strength of from 27 to 31 tons per square inch, with 16 per cent. of elongation over 8 inches; while the Liverpool underwriters specify from 28 to 32 tons per square inch, with an elongation of 20 per cent. in the 8-inch test-piece. The French Admiralty take a somewhat higher strength, specifying for $\frac{3}{4}$ -inch plates a minimum tensile strength of 28 tons to the square inch; or for plates above $\frac{1}{4}$ inch in thickness but under $\frac{3}{4}$ inch, the minimum strength is required to be $28\frac{1}{2}$ tons to the square inch of section. Beyond these tests for tensile strength, the British Government require in the mild

steel for their use that strips $1\frac{1}{2}$ inch in width, cut either lengthwise or crosswise from the plates, shall *bend over cold* under the press to a curve whose corner radius is equal to that of the thickness of the plates; and that a similar strip after heating uniformly to a low cherry-red heat, and then suddenly cooling in water at a temperature of 82° Fahr., shall bend under the press to a curve whose corner radius is $1\frac{1}{2}$ times the thickness of the plate; whilst for rivets, angles, &c., the forge tests for malleability (Fig. 3) are also enforced—that is, the metal is required to bend cold, as in No. 1 (Fig. 3), to a curve whose inner diameter is equal to the diameter of the rivet, and the rivet is to be capable of bending hot without fracture, as shown in No. 2 and, further, the rivet-heads are to stand hammering down hot, as in No. 3, without cracking at the edges, until the diameter of the head is $2\frac{1}{2}$ times the diameter of the shank. Nos. 4 and 6 represent forge tests to be made hot upon the angle iron No. 5, while 7 and 9 are like tests applied to T-iron of the section No. 8. The *tests applied to rails* vary with the weight and section, and consist of a dead weight and of a falling weight test; with double-headed steel rails weighing 70 lbs. to the lineal yard, two blows from a tup or falling weight of 20 cwts., falling from a height of 18 feet, should not produce more than 3 inches of deflection upon such a rail, supported upon centres 3 feet 6 inches apart; and the same rails, supported in like manner, are required to yield a deflection of not more than $\frac{3}{8}$ -inch under a dead weight of 28 tons applied at the centre.

672. Dr. Dudley, in specifying for steel rails to be used on the Pennsylvanian Railway, prescribes the limits of chemical composition, as also of tensile strength to which the rails shall conform; and for this purpose he considers that the carbon should be between 0.25 and 0.35 per cent., with phosphorus not above 0.1 per cent., silicon not greater than 0.04 per cent., and manganese from 0.3 to 0.4 per cent., and such metal is to have a minimum tensile strength of 29 tons to the square inch, with a minimum

elongation of 20 per cent. of its length over a test-piece 8 inches long.

673. Thus, while a tensile strength of from 26 to 32 tons may be taken as the best suited to bear the strains and shocks to which ships' plates are subjected, yet for the strength and endurance required in tyres from 46 to 50 tons* per square inch of tensile strength is better; and for axles a tensile strength of from 27 to 30 tons is best adapted, while for tyres and axles a further safeguard is afforded by the drop-test above mentioned.

674. The elasticity, flexibility, and transverse strength of mild steel is also superior to that possessed by "best-best" malleable iron: for whilst a bar 4 inches square of the latter, carried upon supports 39 inches apart and loaded in the centre with a weight of 30 tons, will afford a permanent set of from 1·6 to 1·9 inch; a steel bar of 0·15 per cent. carbon, under the same conditions, will take a permanent set of but from 0·4 to 0·5 inch. The ratio of the limit of elasticity to the ultimate tensile strength in steel is also high; thus, in steel having an ultimate tensile strength of about 24 tons to the square inch the metal will first commence to permanently stretch under a strain of about 13 or 14 tons; or if the metal be of a temper corresponding to a tensile strength of 28 tons to the square inch, a force of 15 tons to the square inch can be applied before any appreciable permanent set is observed; but with the harder tempers of steel the elastic limit attains to 25 or 30 tons to the square inch, whilst in hard-drawn wire an elastic limit of from 45 to 50 tons per square inch is attainable. The quality possessed more or less by all ductile metals, of acquiring additional strength by being stretched as in wire-drawing, is also strongly marked in steel.

675. The power of steel to resist *jerking strains* has been shown to be superior to that of the best iron wire; thus, while an iron wire of No. 14 B. W. G. (·087 diameter), having a tensile strength of 46 tons to the square

* Mr. Baker, C.E.: *Proceedings of Institute of Civil Engineers*, 1882.

inch, withstood the effect of but four jerks from a weight falling $6\frac{1}{2}$ feet, a steel wire of the same dimensions, but having a tensile strength of 57 tons to the square inch, withstood sixteen jerks of the same weight.*

676. The advantages of mild steel over iron for structural purposes, as enumerated in preceding sections, are thus an increase of from 30 to 50 per cent. in tensile strength, with greater elasticity, ductility, power to resist jerking strains and greater powers of endurance; whilst plates, bars, forgings, &c., can also be made in much larger pieces than is possible with iron, thereby diminishing the number of joints in the structure. The superiority in respect to waste or corrosion is perhaps not fully ascertained, but the difference as yet appears in favour of steel. The use of steel for structural purposes can only be said to date from 1851,† since which year rapid progress has been made in its introduction; and owing to its greater strength the Board of Trade regulations now permit steel to be worked up to a tensile strength of $6\frac{1}{2}$ tons to the square inch, as against 5 tons allowed as the working stress upon malleable iron; hence steel structures can be made of less weight than iron ones for the same strength, and its use will thus increase the carrying power of the structure by diminishing the dead load arising from the weight of the structure itself.

CHAPTER XVIII.

THE METHODS EMPLOYED IN THE PRODUCTION OF STEEL.

677. Steel is produced on the large scale, either 1^o, directly from certain pure iron ores, 2^o, by the carburisation of malleable iron, or 3^o by the decarburisation of pig-iron.

678. The direct reduction of iron ores for the production of steel embraces the reduction in the Catalan

* *Revue Universelle des Mines*, 1881.

† Sir W. Siemens, Iron and Steel Institute, 1877.

forge, in the Siemens Rotator, by the Chenot process, &c., in each of which processes rich ores of iron, such as the purer oxides, are heated along with charcoal or carbonaceous matters, and thereby either steel or a hard steely iron is produced.

679. The carburisation of malleable iron by the addition thereto of carbon, through solid or gaseous carbonaceous matters, is represented by the "cementation" and the "crucible steel" processes.

680. The decarburisation of pig-iron for the production of steel comprises—1. The puddling, the finery, and other processes in which a partial decarburisation of pig-iron takes place; 2. the fusion of pig-iron with rich iron ores or oxides of iron, in the manner pursued in the Uchatius and in the Siemens open-hearth direct process; 3. the fusion of pig-iron with malleable iron, as in the Siemens-Martin process; and 4. the *Bessemer* or pneumatic process, in which the decarburisation and purification of pig-iron necessary for the production of steel are effected by a powerful blast of atmospheric air forced through the molten pig-iron.

PRODUCTION OF STEEL BY THE DIRECT REDUCTION OF THE IRON ORE.

681. The "Catalan Furnace," and the apparatus for producing the required blast, together with the general working of the furnace, have been already described (p. 217). The production of a uniformly carburised steel is not possible in this furnace, and at most but a steely iron results, while, according to the skill of the workman, a larger or smaller proportion of steely or soft iron will be produced from the same materials.

682. If steely iron is to be produced in the Catalan forge, then special conditions need to be observed in the charging and working of the furnace, since the decarburisation is not required to be carried so far as when soft iron is to be obtained; and hence it is necessary to place the twyer at a smaller inclination, whereby the reduction

of the metal from the ore takes place more slowly, and a longer period of contact is allowed between the reduced metal and the incandescent carbon in the furnace; also the charge contains more carbon and a smaller proportion of small ore, while it is also gradually and frequently pushed back during the working from the front of the furnace towards the twyer. The slope of the front of the furnace hearth is likewise made greater; and finally towards the end of the smelting operation less blast is employed than when soft malleable iron is required. For the production of steely iron also a more dense charcoal is employed, whilst a little more manganese in the ores is desirable, and the slag is also tapped out more frequently than is required for the production of soft iron.

683. The mass of hard or steely iron thus obtained from the hearth of this furnace is hammered into blooms and afterwards into bars, which are then broken up and classified according to the fracture; for it is difficult with this, as with all the direct processes, to attain a uniform degree of hardness or carburisation in the product.

684. The Catalan, like the so-called natural steel processes of Styria, Westphalia, and other parts of the South of Europe, has, however, been gradually superseded by the more scientific and readily controllable steel-producing processes of Bessemer, Siemens, and others.

685. The "Chenot process" for the production of steel direct from the ore involves two operations or stages, in the first of which a metallic sponge is obtained, and in the second operation this sponge is melted in crucibles along with carbonaceous matters. For the preparation of the iron sponge, the iron ores are treated in vertical retorts or the chambers, along with more charcoal than is sufficient to remove the oxygen in the ore; the reduction of the ore for the production of a metallic sponge in this manner occupies from three to five days, and is conducted in the apparatus and substantially in the manner already described (p. 225).

686. The metallic sponge obtained from the Chenot

apparatus is then melted in crucibles, either along with charcoal, or with other solid substances rich in carbon, such as a mixture of resin and charcoal; or the sponge may be saturated with fluid matters rich in carbon, such as wood-tar or fatty substances, but in all cases the materials added for the carburisation of the metallic sponge must be free from sulphur. When fluid carburising materials are employed it is usual to first grind the metallic sponge, and then immerse it in the carburising fluid until complete saturation occurs, a gentle heat being applied, if necessary, during the process to expedite its completion. The metallic sponge thus saturated is allowed to drain, and is afterwards transferred to covered vessels in which it is heated for about an hour, to a temperature only sufficient to carbonise the fluid matters; or if fatty matters have been employed as the saturating fluid, then the lumps of ore require to be first soaked, and then to be ground with a further proportion of about 75 per cent. of the metallic sponge without any addition of carbon. The sponge is compressed into small masses occupying about two-thirds of its original bulk before it is charged into the crucibles for fusion, otherwise it is so bulky that but a very small weight can be introduced into the crucibles; and even after compression the charge per crucible does not exceed 40 or 50 lbs., or considerably less than is charged when bar-iron or blister steel is employed, as in the ordinary crucible process of steel manufacture. The fuel consumed per charge is about the same in the Chenot as in the ordinary crucible process; hence the consumption of fuel per ton of steel produced is considerably greater in the Chenot than in the crucible process, and the former has accordingly been generally abandoned in England. During the fusion of the metallic sponge in the crucibles, the gangue, &c., rises to the surface, and is solidified and removed by projecting upon its surface a small quantity of sand, and then skimming off the partially solidified slag, &c., before teeming the metal into ingots.

687. The Siemens direct process for the production of steel in the Siemens regenerative rotating furnace has been already described (p. 213), but the process, as now applied to the manufacture of steel, is generally used only as a preliminary stage in the production of steel in the open-hearth steel-melting furnace, to which furnace the balls of metallic sponge, or the shingled blooms from the same, are at once transferred from the rotator for fusion with the other materials of the ordinary charge of the steel-melting furnace.

METHODS EMPLOYED FOR THE PRODUCTION OF STEEL BY
THE CARBURISATION OF MALLEABLE OR BAR-IRON.

688. These methods embrace the "cementation" and the "crucible steel" processes, and rank as the oldest of the steel-making processes in anything like general use, and they are still pursued in Sheffield and elsewhere for the production of the steel required for the various edge and cutting tools, files, &c., practically in the same manner as when first introduced. The steels produced by these methods constitute the purest form of the metal, being often produced simply by the addition of carbon to thoroughly fined Swedish malleable or bar-iron, giving little chance, therefore, for the presence of any large proportion of those impurities generally occurring in the cruder forms of commercial iron or steel.

689. In the Cementation process for the conversion of bar-iron into cementation or blister steel, the bars of iron suitably embedded in charcoal, with the exclusion of atmospheric air, are subjected to the long-continued action of a temperature of about 1170° C. (2142° Fahr.), or a temperature approaching to whiteness. The process is conducted in a *converting or cementation furnace* (Fig. 82), which resembles externally the ordinary glass-house furnace, and consists of an oblong, rectangular, fire-brick arched vault or chamber, A, supplied with chimneys, B, B, and which is divided longitudinally by a long narrow fireplace, C, provided with a door at either

extremity for the introduction of fuel to the fire. The depth of the fireplace varies according to the fuel and the

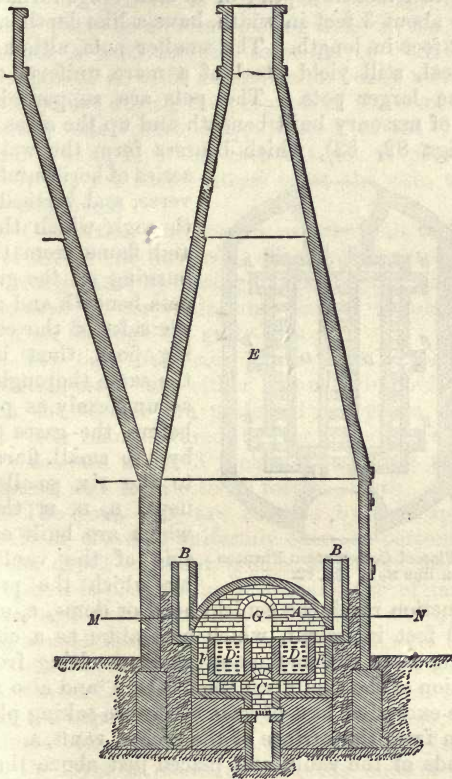

Fig. 82.—Sectional Elevation of the Cementation Furnace.

size of the pots employed, whilst upon each side of the fireplace and running for the full length of the furnace, are placed two fire-stone or fire-brick open-topped boxes

or troughs, D, D, called "pots," placed about 18 inches apart, and each measuring from 8 to 15 feet in length by from $2\frac{1}{2}$ to 4 feet in depth; or in an average furnace they measure about 3 feet in width, have a like depth, and are some 12 feet in length. The smaller pots, although less economical, still yield steel of a more uniform quality than the larger pots. The pots are supported upon bearers of masonry built beneath and up the sides of the pots (Figs. 82, 83), which bearers form the walls of a

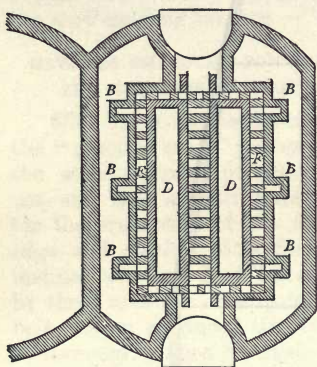

Fig. 83.—Plan of Cementation Furnace on line M, N, Fig. 82.

series of horizontal, transverse, and vertical flues, through which the heat and flame from the fire burning on the grate, C, pass beneath and around the sides of the converting pots, thus heating the same thoroughly and as uniformly as possible before the gases escape by the small flues, F, F, to the six small chimneys, B, B, B, three of which are built on each side of the vault, and by which the products

of combustion reach the conical hood or dome, E, of some 30 or 40 feet in height, which acts alike as a chimney for taking away the smoke and gases resulting from the combustion of the fuel upon the fire-bars, and also to prevent the excessive loss of heat otherwise taking place by radiation from the surface of the arched vault, A. In the brick ends of the vault, and placed just above the level of the top of the converting pots, is a *man-hole*, G, of sufficient size to admit of the entrance of a man for charging the bars, &c., into the pots, and for the withdrawal of the charge or heat when the process is completed; this man-hole is built up close during the

working of the furnace, and is opened for the cooling down of the same immediately the conversion is completed. In one end of each pot is a small *tap-hole*, and opposite to each of these is a corresponding hole in the furnace wall, which is used for the insertion of "trial or tap bars," so placed as to be accessible for ready withdrawal and examination during the progress of the cementation. Occasionally one chest only, instead of the two just described, is used, in which case the pot is placed centrally over the fireplace instead of at the side, as when two are employed.

690. Converting furnaces are usually built together in ranges of five or six furnaces. The temperature in each furnace is regulated by closing or opening the small flues, B, in the arch of the vault, and also by regulating the supply of air through the grate-bars.

691. The bars for conversion into "blister" or "cementation steel" are either hammered or rolled bars, of which the former are preferred; they are often of Swedish iron manufactured by the Lancashire process (p. 233), and are about 3 inches in width, $\frac{5}{8}$ to $\frac{3}{4}$ inch in thickness, and from 6 to 12 feet in length.

692. The pots, D D, are charged by first spreading small nubs of charcoal uniformly over the bottom of the pot to the depth of about $\frac{1}{2}$ -inch, and upon the bottom thus prepared is placed a longitudinal layer of malleable iron bars, with their flat sides downwards and upwards, allowing a small space between the long edges of the bars for the introduction of charcoal, and also a sufficient allowance must be made both in length and in width to admit of the expansion of the bars by the heat; whilst, if the single bars are too short to fill the full length of the pot, the layer is made up with the ends of bars or other short pieces. Upon the layer of bars so introduced into the pot a second layer of charcoal is spread uniformly, and of a depth as before, then another layer of bars, and so on alternately, charcoal and bars, until the pot is quite filled or the required charge has been intro-

duced, the top layer, however, in every case being formed of charcoal. The surface of the last layer of charcoal in the pot is then covered or plastered over with "wheelswarf," the latter being the mud which collects in the trough of the grindstones employed for the grinding of the steel goods in Sheffield, &c., and it hence consists of siliceous matters from the grindstone with particles of steel more or less oxidised, and it thus forms a material which, under the influence of the heat of the converting furnaces, fuses or frits so as to form a pasty mass or glazed air-tight covering to the pot.

693. The charcoal employed in the cementation process is by preference that yielded by the harder woods, such as oak, and it is mixed for use in equal proportions of fresh charcoal and of such as has been used in a previous charge, after the latter has been separated from the fine soot-like dust accompanying it, by washing and sifting it through a riddle of from $\frac{1}{2}$ -inch to $\frac{3}{4}$ -inch meshes. Such a mixture of charcoal is preferred to all fresh charcoal, since the process is more rapid with the mixture than with all raw charcoal.

694. The charge of from twelve to eighteen tons, or, in special cases of as much as thirty tons of bars, having been placed in the pots along with the necessary charcoal, &c., the man-hole is then bricked up, the space around the trial bars is luted with clay, and all other apertures are made tight, whereupon a fire is made on the grate and the temperature of the furnace gradually raised, so that a red-heat is attained in about twenty-four hours; but it is some forty-eight hours before the glowing heat required for conversion is attained, upon which the temperature is then steadily maintained, without rising or falling unduly, until the desired degree of conversion has been reached, as determined by the withdrawal and examination of the trial bars from time to time. The process lasts from seven to nine or ten days, according to the temper or degree of carburisation needed in the blister steel: since the harder the temper the longer is the dura-

tion of the exposure of the bars to the carburising influence of the cementation process. Thus a "spring temper" is obtained after about seven days' exposure, whilst *shear steel* requires about eight days, and a welding temper will occupy from nine to ten days; but throughout the process the temperature of the pot and the progress of the conversion are observed by withdrawing a trial bar through the tap-holes already named, and by an examination of the surface and fracture of this bar the progress of the carburisation is determined, for at No. 1, or "spring heat," constituting the lowest temper of blister steel, the fracture presents an outer skin of steely iron enveloping a kernel or core—"sap," as it is called—of comparatively unaltered bar-iron. As the conversion of the bar progresses, the steely character penetrates more and more towards the centre with a corresponding reduction in the area of sap, until in No. 4, or "double shear heat," the outer crystalline or steely portion, and the inner nucleus of unaltered iron, form about equal proportions of the section of the bar, although the one part merges into the other without any sudden demarcation of their limits. If the bars show any sudden demarcation between the outer and inner portions it is an indication that the temperature and rapidity of conversion are proceeding too rapidly. In No. 6, or "melting heat," as this temper is called, the crystalline structure of steel has entirely replaced the fibre of the original iron, and there is no longer any inner nucleus of unconverted bar-iron.

695. The desired temper of blister steel having been thus secured as decided by the examination of the trial bars, the fire is then allowed to burn down and the furnace to cool during three or four days, when the man-hole is opened, and in about two days afterwards the whole furnace is sufficiently cold for a man to enter, when the discharge of the pots, or, as it is called, "drawing the heat" commences, the bars being afterwards broken and classed according to the fracture presented by the bar.

696. The coal used in heating the converting furnaces is a white-ash coal, which burns regularly and uniformly without clinkering, and of such coal the furnaces consume from 70 to 90 per cent. of the total weight of the bars converted. Although in some furnaces very large converting pots are employed, it is found that the smaller-sized pots yield a better and more regular product; and, as already stated, the best blister steel is made by the use of Swedish bar-iron produced from magnetic iron ores, and such bars as have been hammered are generally preferred to those that have been rolled.

697. The bars of blister steel or converted bars as produced by this process no longer show the even, smooth surface, fibrous structure, and bluish colour of bar-iron, but now present a rough, blistered surface, with a scaly or crystalline fracture, and a browner or more yellowish tinge. The specific gravity of the converted bars is also lower than that of the original bar-iron, while the total weight of converted bars or blister steel withdrawn from the furnace is from $\frac{1}{2}$ to $\frac{3}{4}$ per cent. in excess of the weight of bars introduced. The carbon in the metal has increased during cementation from about 0.2 per cent. as existing in Swedish bar-iron up to from 0.5 to 1.5 per cent. in the blister steel, the proportion varying according to the duration of exposure to the cementation and the consequent temper of the blister steel bars, but the proportion of sulphur in the converted bars is only about one-half of that in the original bar-iron (Bousingault). The blisters on the surface of the steel vary from the size of a pea to an inch or upwards in diameter, but small blisters uniformly distributed are generally considered as indicating a good quality of metal, whilst large and irregularly disposed blisters are an indication of a want of homogeneity in the original bar-iron; but blister steel is never perfectly homogeneous, for even after hammering or tilting it still contains mechanically mixed impurities such as slag, &c., which cannot be separated except by the fusion of the converted bar.

Bars from the same heat also differ considerably in temper, arising from differences in the original bar-iron, as also from irregularities and fluctuations in the temperature of the different parts of the chest or pot during the cementation process.

698. Bars showing signs of fusion upon the surface are described as "glazed bars," and indicate that the heat of the furnace has been too high; while "aired bars" result from the access of air to the heated bars within the pots during the process of cementation. Aired bars present a rough surface, and are more difficult to break owing to the presence of a tough skin of iron upon their exterior; but both glazed and aired bars are defective in quality, are unfit for melting purposes, and require reconverting.

699. The action according to which a portion of the carbon in which the bars are embedded is transferred from the exterior gradually towards the centre of the bars during the cementation process has not yet received a satisfactory solution; and the determination of the causes of the blister-like excrescences invariably occurring on the surface of the converted bars has also been the subject of much theoretical and experimental research by Dr. Percy and others. The blisters would appear to have been formed by the efforts of gaseous matter to escape from the interior of the bar when the outer skin of the bar was in a soft or pasty condition, such efforts thus raising the blisters upon the surface; and since all bar-iron produced either in the charcoal finery or by the puddling process contains more or less intermixed slag or cinder, consisting of ferrous silicates with an excess probably of magnetic oxide of iron, Dr. Percy * concludes that a portion of the iron from this cinder is reduced by carbon at the temperature of the converting furnace with the evolution of carbonic oxide, which, in its efforts to escape through the soft skin of the bars would raise the blisters in the manner

* Paper before the Iron and Steel Institute, 1877.

presented on the surface of the bars of blister steel; and he further shows that, by separating the slag and cinder from the malleable iron, as by melting the same and casting the metal into an ingot free from slag, the bars made from such an ingot do not present after cementation the blistered surface of the ordinary cementation bars.

700. *Blister steel* is not uniform or homogeneous in either texture or composition throughout the bars, and, except when used for melting purposes, it is cut up into suitable lengths, which are piled or faggoted, reheated in a hollow coke fire, welded together, and drawn out under the hammer or by rolling into bars, forming according to the degree of its carburisation the *spring* or *single-shear steel*, and the *double-shear steel* of commerce.

701. The *shear steel* thus produced is void of the laminated structure of blister steel, whilst the fracture and texture of the metal are also more regular, and its composition is more uniform, although the faggoting and welding have a tendency to partially decarburise or reduce the temper of the steel. The piles or faggots for welding are dusted over with either powdered clay or with sand and borax before introduction into the hollow fire, whereby the steel is protected as much as possible from the oxidising and decarburising influence of the blast in the hollow fire during the process of raising the piles to a welding heat.

702. *Single-shear steel* is either again cut up or otherwise simply doubled upon itself, and again reheated, rewelded, and drawn into bars for the production of *double-shear steel*, the last-mentioned often containing upwards of 1 per cent. of carbon.

703. *Case-hardening* is a rapid process of cementation according to which small articles of wrought-iron, after forging and finishing to form and dimensions, but before being polished, have their surfaces converted for a small depth into hard steel. This is effected by heating them with substances rich in carbon, such as bone-charcoal, parings of horses' hoofs, horn, leather

cuttings, or charred skins, along with a little common salt. The articles to be case-hardened are placed in wrought-iron boxes along with the animal matters just enumerated, in which the articles are thoroughly embedded, when, after luting up the box completely so as to exclude atmospheric air, the box and its contents are heated on a smith's hearth or placed in a suitable furnace. A furnace resembling those used in cementation is frequently employed. The box and its contents are raised to a cherry-red heat, at which temperature the whole is maintained during from twelve to twenty-four hours, according to the size of the articles, the degree of hardness, and the depth to which the hardening is to penetrate. After a sufficient exposure to the heat of the furnace, the fire is allowed to burn out, the box is withdrawn from the furnace, and the articles are either taken out whilst still red-hot and plunged at once into cold water, or the whole is allowed to cool down, when the articles after removal are reheated and quenched in cold water as in the ordinary hardening process. In this manner considerable hardness of the surface is produced, whilst the interior preserves the softness of the original wrought-iron. Bone-charcoal alone may be used for the purpose of case-hardening, but the addition of leather or hoof-parings appears to expedite the process. If there are portions of the articles which it is not desirable to case-harden, such portions are coated with clay before being inserted into the case-hardening boxes.

704. Small articles are case-hardened by heating them to redness, and then sprinkling powdered *ferrocyanide of potassium* over the heated surfaces, after which the articles are returned to the fire for a few minutes until the ferrocyanide quite disappears from the surface, upon which they are withdrawn, and finally cooled down by being dipped at once into cold water.

705. Cast or crucible steel was first produced upon a working scale and introduced into Sheffield by Huntsman in 1740, when he succeeded in effecting the entire fusion

of the metal placed in crucibles standing upon the bars of an air furnace which was heated by a coke fire surrounding the crucibles; and finally he cast or poured the molten steel into cast-iron moulds for the production of homogeneous ingots. The practice as then introduced is still pursued practically without modification in Sheffield and other crucible steel-producing works on a large scale, for the manufacture of the special qualities of steel required for certain tools, tyres, forgings, castings, &c.

706. Although by the repeated reheating, hammering, and tilting of blister steel a tolerable degree of uniformity of composition and structure can be obtained in the bars produced therefrom, yet, as already noted, blister steel, for the reasons named (p. 412), is never homogeneous, however much it may be treated under the hammer; and it can only be freed from its mechanically mixed impurities and rendered perfectly homogeneous by breaking up the cemented bars and melting them in crucibles, and subsequently casting the metal into ingots of so-called "cast-steel."

707. **Cast, crucible, or homogeneous steel**, as the same product is variously called, is hence largely produced by the melting of blister steel in crucibles or pots; whilst bar-iron, carbon, manganese ores, or spiegeleisen are one or more of them frequently added to the charge of blister steel, according to the temper and quality of metal to be obtained in the cast-ingot. But cast crucible steel is also very largely produced by the fusion in crucibles of bar-iron or puddled steel along with carbon, black oxide of manganese, or spiegeleisen in small proportions.

708. The **steel melting house**, or "furnace," as the part of the works devoted to the melting and casting of steel is called, is somewhat variously arranged according to the class and weight of work intended to be carried on therein; but as arranged for casting the usual run of small ingots required for the very extensive light trade of Sheffield, the furnace or melting house consists of various

numbers of *melting holes*, or *fires*, arranged along one or both sides of the melting house. The construction of the melting holes is the same, except as to size, for both the light and heavy trades; but the general arrangements of the melting department are somewhat modified, as will be subsequently described when heavy ingots are the general production. In the middle of the floor of the melting house are the *teeming holes*, or small pits, of about 3 feet in length and 2 feet in width, with a depth varying with the length of the ingots to be cast. The teeming holes are covered over with iron plates placed level with the general floor, except during the period of casting or teeming or the preparations for the same. The bottom of the pits are prepared with a layer of small coke, upon which the several moulds stand for the reception of the metal from the crucibles.

709. The *melting holes* or *fires*, A (Fig. 84), form a series of rectangular chambers arranged along the sides of the building, and which measure about 3 feet from the centre of one hole to the centre of the next, a single brick wall separating the holes from each other; but each hole is lined with a refractory lining of some 6 inches in thickness, formed of fire-brick tiles or of ganister, so that the melting hole when finished ready for the reception of the crucibles, is an oval chamber measuring about 26 inches in its major diameter by 19 inches in its minor diameter, and about 3 feet in depth from the level of the floor to the top of the fire-bars. When ganister, as is usual, forms the lining material, it is rammed in position by first placing upon the grate-bars a wooden model of the internal form of the fire, and upon the top of which the workman stands and rams in, with a light iron rammer, the moistened ganister placed around the model, thus leaving, on the withdrawal of the model, a cavity of the dimensions above mentioned and capable of holding two pots or crucibles. The top around the mouth of the fire is formed by an iron plate placed but very little above the level of the floor. The grate-bars, B, are carried upon

bearers built in the masonry, while beneath the grate-bars is the *ash-pit*, c, the bars and ash-pit being readily accessible from the underground *cellar* or vault, d, which runs parallel with, and in front of the fires, thus giving

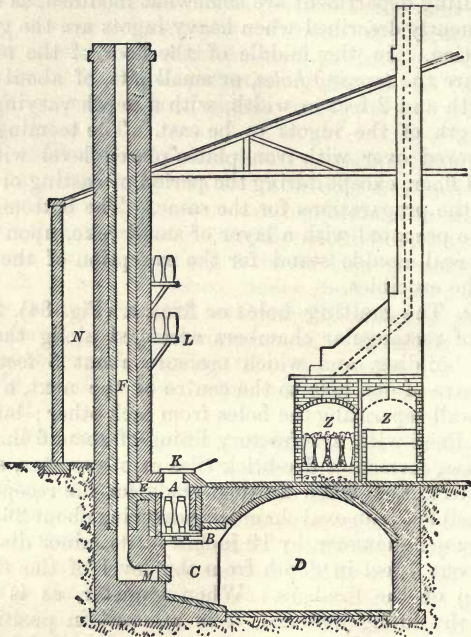

Fig. 84.—Crucible Cast-steel Melting Furnace.

access to the bottoms of running pots and the like during the working of the fires, since, by withdrawing a fire-bar or two, enough fuel falls into the ash-pit to enable the workman to examine, and, may be, to stop the hole in the running pot, &c. The cover of the fire is formed by a square fire-brick, tile, quarry, or slab, k, about

3 inches in thickness, held in a wrought-iron frame provided with a projecting bar or handle for moving the cover from over the hole. Each fire is provided with its own flue in the form of a small rectangular passage, E, of considerably less sectional area than the furnace itself; this flue leads into a flat vertical chimney or stack, F, of about 40 feet in height, which is continued downwards below the flue, E, to the ash-pit into which it opens at M, and by the insertion of a brick into this opening, and also into the flue, E, the draught of each fire can be regulated so as to either urge or to keep back the fires as may be necessary when making large ingots, in order that all the metal may be melted and in proper condition for teeming at the same time. Five or six of the vertical or chimney flues, F, are carried up together, forming one block or stack for as many holes as there are flues, F, the adjoining batch of holes to the same number having their flues carried up together in the same manner. Each fire or hole as thus described, holds two pots or crucibles, each supported upon its own stool or stand (Fig. 4) of about 4 inches in thickness, to which height the crucible is raised above the fire-bars.

710. Around the sides of the melting house are fixed shelves, L, upon which the fresh or green crucibles are placed for drying before use, but these are not found in such of the large establishments as are specially provided with drying chambers; while outside the walls of the melting house it is usual to place the sheds, N, in which the clay for the manufacture of the crucibles or pots is stored for drying and tempering by the heat of the walls of the melting house.

711. The *crucibles employed in steel melting* are usually from 16 to 18 inches high, and 6 or 7 inches in diameter at the mouth, but special crucibles as also larger sizes are now frequently used. These pots are made of mixtures of fire-clays from the coal-measures, with potsherds, coke dust, graphite, &c., as described on p. 26, and are covered by lids during the fusion of

the charge of metal, the lids being also made from fire-clays, but of an inferior class to those employed for the crucibles. The crucibles, besides being well dried and seasoned for at least two weeks between being made and used, require, previous to insertion into the melting furnace, to be slowly and gradually raised to redness, for which purpose the melting house is provided, at one end, with "annealing ovens," z, z (Fig. 84). These are rectangular chambers of fire-brick, each capable of holding twenty or thirty crucibles, which are fitted at the front with iron doors sliding upwards and downwards, while above each chamber is a small flue for carrying away the products of the slow combustion of the fuel on the grates. Upon the fire-bars of each annealing oven a layer of live coals and small cinders or coke is spread, and upon this a batch of from twenty to thirty crucibles is placed, each with its mouth downwards, and the spaces between the crucibles are then filled up and the whole covered with small coke, after which the sliding door is lowered and luted around, thus closing the front of the grates. Combustion on the grate-bars goes on very slowly, and the temperature throughout the crucibles only attains to redness after the lapse of several hours, hence the crucibles are usually placed in the ovens in the afternoon or evening and left there until the following morning, when they are at a black-red heat, and are removed by tongs for conveyance to the melting holes into which each is inserted and placed upon its own stand in the fire.

712. The pots having been thus placed in the melting holes, into which a small quantity of live coals has been previously introduced, the fires are now filled up with coke to the level of the top of the crucibles, and the whole is allowed to burn up slowly, so that in from twenty to thirty minutes the pots are at a red heat and charging of the metal into them commences. With hand-made crucibles there is a hole left in the bottom of each pot, and the first operation with such pots is to go around the fires and throw a handful of sand into the bottom of each,

which thus fills the hole, and frits or softens at the temperature of the melting hole, so that the crucible and its stand, after the melting of the charge, are usually fixed together and are drawn from the fire firmly attached when the pots are lifted out for teeming.

713. The charge of blister steel, which has been previously assorted and broken up into small pieces, and weighed up into the crucible charges of from 40 to 60 lbs. each, is now introduced into the crucibles through a wrought-iron funnel-shaped charger, placed by one man over the mouth, whilst another empties the charge of metal from the pans into the mouth of the charger, a little black oxide of manganese being also sometimes added along with the charge. The cover of each crucible is now replaced, and the fires are made up with hard coke to slightly above the level of the flue, E, when the cover, K, is placed over the melting hole, and in from forty-five to fifty-five minutes this first fire will have burnt off. The workman introduces his bar and potters down the fuel hanging about the bottom and sides of the pots, so that in the next firing the coke gets down to the bottom of the pots, for otherwise, whilst the top of the pot would be red-hot, the lower end would be comparatively cold, and the metal probably set in the crucible owing to the fire drawing in cold air at the bars, which would not meet with combustible coke for some distance up the pots, and hence the surface of the fire and top of the crucible would be at the highest temperature although the bottom might be cold. When the *second fire* has burnt off, the charges will have begun to melt, and the lids of the crucibles are then turned off, when the melter goes round with an iron bar and introduces it into each pot, by which he can feel whether the metal is all fused, or whether any lumps of unmelted metal still remain, and he gives instructions accordingly as to the amount of fuel to be added to each hole in this the third and last firing, so that the whole number of crucibles may be ready at the same time. When the

third fire has burnt off, the charges in the several pots ought to be in a complete state of fusion and ready for teeming. The melting thus occupies from four to five hours according to the temper, &c., of the steel, but a second heat of somewhat lighter weight is worked off in much less time, about $2\frac{1}{2}$ hours being usually sufficient for a second heat from the same fires and crucibles.

714. The crucible charges being thus thoroughly melted, the fuel of the fire is again pottered down to admit of the introduction of a pair of tongs with strong concave jaws fitting around the belly of the pot, a little experience being required on the part of the "puller-out," or workman who lifts the crucibles from the fires, so that he shall put sufficient pressure on the pot to ensure its being drawn out without slipping from his grip; but yet the pressure must not be such as to crush up the crucible, for the pots are occasionally somewhat tender at this elevated temperature, and are also a little weak and thin along a line around the top surface of the fluid metal owing to the corrosion of the crucible at this point by the slag floating above the molten metal.

715. The crucible with its contents of fluid metal, having been withdrawn from the fire and landed on the floor by the puller-out, is seized in the bowed jaws of a pair of tongs, forming a barrow mounted on a central pivot fixed to the axle of a pair of wheels, whereby the pot can be inclined for teeming, and also raised from the ground so as to be run along the iron-plated floor either to the ladle, or to the teemers at the moulds, according to the size of the ingots to be cast. With small ingots of from 2 to 7 or 8 inches in diameter the ingots are teemed by hand, but with larger sizes the metal from the crucibles is first emptied into a wrought-iron ladle lined with fire-clay, and provided with a tapping-hole fitted with a fire-clay plug or stopper in the bottom, from which the metal is afterwards delivered in a continuous stream into the cast-iron ingot mould. The ingots produced from the melting of blister-steel are,

however, usually of the smaller classes and are teemed or cast by hand into *ingot-moulds*, which are cast in two halves so as to part in the direction of their lengths for facilitating the warming of the moulds, the coating of their inner surfaces and the removal of the ingots therefrom. The two halves of the moulds are held together by rings passed over them and tightened by wedges driven in between the inside of the ring and the outside of the mould. Before using the moulds each half is warmed, and to prevent the adhesion of the ingot the mould is coated on its inner surface with a layer of carbon, applied by wiping over the heated mould with oil, or instead of carbon the inner surface is painted over with a cream of fire-clay and water, or, as is very generally pursued, coated with coal-tar soot by placing a number of the halves of moulds with their inner surfaces downwards, across a gantry, and then passing beneath them an open iron box in which coal-tar is burning with its smoky flame and emitting large quantities of unconsumed carbon, which is deposited upon the surface of the moulds. After the halves are so coated or *reeked* they are fitted together and placed in the *teeming-holes* in the middle of the melting-house floor, the moulds being fixed at a slight inclination towards the teemer that he may the better teem or pour the metal from the crucible clean to the bottom of the mould without touching its sides, otherwise the hot steel scores out the metal from the mould and fixes the ingot therein. As fast as the teemer can empty the contents of the crucibles into the moulds, relays of crucibles are brought to the teeming-holes from the fires in the barrows already named.

716. Before teeming, the metal in the crucible is first *skimmed* or cleared of the slag floating on its surface by the introduction of mops consisting of a bar of iron to which a knob of slag is already attached. The mop, after warming, is inserted into the crucible, where it immediately cools the slag with which it comes into contact,

and collects it upon itself; and by moving the mop around and over the surface of the molten metal, the whole of the slag can be thus removed, whereupon the clean surface of the metal presents itself and the teemer judges of the best temperature at which to cast the metal, allowing it to stand in the crucible for a minute or so, if he judges it to be too hot. If the mould takes more than the contents of one crucible to fill it, it is usual to empty two pots into one, or "*double the pots,*" before commencing to teem; and if this be still insufficient, then two teemers are employed, who can keep up a continuous stream of metal into the moulds until they are filled.

717. After the teeming is completed, the pots, if in good condition, are again received in the barrows and returned to the pullers-out at the fires, who, after detaching adhering slag and clinker from the bottoms of the pots, replace them in the fires for the reception of a second charge.

718. The *softer tempers of crucible steel* rise or boil in the moulds after teeming, and before the metal solidifies, producing a vesicular or honey-combed structure; and to partially prevent this, it is the practice immediately after casting such metal to insert a loosely-fitting cast-iron stopper on to the top of the fluid steel in the mould, and to throw over and around the stopper a little sand so as to hold it down. Instead of the stopper, sand itself is frequently thrown upon the surface of the metal so as to completely fill up the mould, when a plate of sheet-iron is placed over this, and the latter held down by a wedge passing through two eyes cast in the top of the mould for this purpose. *Harder tempers of steel*, containing 0·7 per cent. of carbon and upwards, settle down after teeming, leaving a hollow or funnel-shaped tube or pipe at the top of the ingot, which requires to be broken off, or the ingot "*topped,*" as it is called, before working the same. By experience and care in the manner of teeming and in the temperature at which the metal is cast, the

honey-comb and rising of soft steel, or the piping of the harder tempers of metal, can be considerably reduced. The difficulties of unsoundness are greatest with the very mild tempers of steel, but *dead-melting* and careful teeming produce fairly sound ingots where the content of carbon in the steel amounts to about 0·5 per cent., whilst piping can be mitigated by teeming the metal slowly towards the end of the cast, so as to continue the flow of metal into the mould whilst the process of setting is going on, and thus partially filling up the pipe.

719. When the metal throws out sparks or teems fiery, it is said not to be "killed," and it is indicative of the metal not having been sufficiently long in the fire after fusion, and such steel will yield unsound or honey-combed ingots; whilst too long exposure to the heat, or extreme "dead-melting," produces a metal that runs dull and dead, affording ingots also of inferior quality.

720. The pots or crucibles having been emptied, and such as are in good condition replaced in the melting holes, after the clearing away of adhering slag, &c., from around the bottoms of the crucibles, the recharging for the "second heat" at once commences. The procedure observed in the second is exactly similar to that of the first heat, except that the crucibles which were charged with 70 lbs. of metal in the first heat now receive but 50 or 55 lbs. of metal, or if the smaller crucibles carrying but 50 or 55 lbs. in the first heat are in use, then from 40 to 45 lbs. only are charged in the second. The time required for the melting of the second heat is, as previously stated, only about $2\frac{1}{2}$ hours, and the coke consumed per ton of ingots produced is likewise less than in the first.

721. A *third* and occasionally a *fourth* heat is made in like manner, but each time with a weight of charge less than that of its predecessor; but after from three to five continuous heats the "fire" requires to cool down, otherwise the temperature becomes so high that rapid corrosion of the melting hole ensues, thereby increasing its area as also the consumption of fuel;

before, however, this point is reached the crucibles have usually become too thin and tender to permit of further meltings being made in them with safety.

722. Each of the ordinary white pots in which medium or hard tempers of steel are melted, ought to stand three heats with charges of 50, 45, and 38 lbs. of metal respectively; but for melting the softer tempers the heavier charges and larger black or plumbago crucibles are used, which last much longer. The ordinary steel-melting crucibles after once being allowed to cool become useless, for they cannot be reheated without danger and almost certainty of fracture; but special plumbago crucibles may, with care, be cooled and reheated.

723. From $2\frac{1}{2}$ to 3 tons of hard coke, according to the hardness of the steel produced, are consumed in melting 1 ton of steel by the above process, but if the coke be soft and dirty, then this amount is increased, and the consumption attains occasionally to as much as $4\frac{1}{2}$ or 5 tons of coke to the ton of ingots produced.

724. The arrangements above described for the casting and teeming of steel ingots prepared by the fusion of blister-steel are observed when similar small ingots are to be cast from steel produced by the melting of *bar-iron* or puddled steel with carbon, black oxide of manganese, or spiegeleisen; but for the production of crucible steel ingots weighing 5, 10, 20, or 40 tons each, cementation steel is not employed, the metal for such ingots being invariably prepared either by the melting and carburisation of bar-iron, or by the fusion of puddled steel, the melting-house arrangements being then somewhat different, and the melting holes larger than those last described.

725. In the larger continental works with which the author has been associated, and where the casting of ingots of crucible steel of the heaviest weights is a regular proceeding, the melting house forms in plan a cross, in the centre of which is placed the casting-pit, commanded by suitable cranes for lifting the heavy ingots and moulds

then required; whilst the melting holes themselves are lined with fire-brick lumps, and are built sufficiently large to hold four crucibles each, and the fires are arranged so as to have one hexagonal stack in the centre of the square formed by each four of such melting holes. The charges for each crucible here employed weigh from 70 to 75 lbs. of puddled steel, or of a mixture of puddled steel and bar-iron, the desired temper of the metal being regulated by the addition of small proportions of spiegeleisen or of ferromanganese. The puddled steel for melting purposes is shingled and made into slabs, which are then drawn under the hammer into bars of $1\frac{1}{4}$ inch square, which are cut up at the shears into small pieces suitable for introduction into the crucibles. The procedure observed in firing and melting is the same as that to be described for the production of cast-steel from bar-iron. In such works as produce heavy ingots for the construction of heavy ordnance, the steel usually contains from 0.4 to 0.6 per cent. of carbon, and the crucibles are of the class known in Sheffield as black pots. The crucibles are dried or tempered in chambers through which hot air is constantly driven by a large fan (p. 29), and the pots are kept in these drying chambers until required for insertion into the melting holes, when they are sufficiently warm to permit of their introduction ready charged with metal, without the intermediate special annealing stage described in the preceding sections. After the insertion of the crucibles the fires are filled with coke, and the process proceeds as already described.

726. For the casting of heavy steel-ingots the metal is run into the mould from one or more troughs or runners, arranged so that gangs of men bringing up the crucibles charged with molten steel direct from the melting holes pour their contents into one of the runners so as to keep up a constant flow into the cast-iron ingot mould which stands in the pit in the centre of the melting house or steel foundry, and which mould has been previously well warmed and coated with a wash

of fire-clay. In casting very heavy masses of steel the number of crucibles required and the rapidity of emptying them, do not permit of more than a comparatively small number of the crucibles being returned to the melting holes for a second heat, and the majority of the crucibles, after emptying their contents into the runners, are accordingly dropped through openings in the floor into the cellar beneath, by which arrangement the floor of the foundry is kept clear during the casting process. The heavy masses of steel are allowed to stand in the mould for three or four hours before the mould is lifted or stripped from the ingot, and the latter moved.

727. Other of the continental crucible furnaces are built to hold as many as *twenty-four crucibles* each, in which case the pulling out of the crucibles from the furnace is facilitated by the application of a mechanical arrangement fixed below the ash-pit, and by which the bottom of the furnace with the pots upon it is lifted at once to the level of the floor.

728. The **Siemens regenerative gas furnace** has also been applied to the *melting of steel in crucibles*, with a considerable saving in the amount of fuel consumed. This furnace is supplied with regenerators, reversing valves, chimney stack, and gas-producers as described for the open-hearth steel-melting furnace and the Siemens reheating furnace; and the heating of the furnace, with the course of the gases and of the flame, is directed and controlled exactly in the same manner as described for the furnaces named, except that the furnace for melting steel in crucibles is itself smaller, and the regenerators have, therefore, a proportionately smaller heating surface. The furnace chamber, A, like the ordinary melting hole, is placed below the floor level, the movable arched roof, D, alone standing above the floor (Fig. 85) exactly like the cover of the melting hole first described. One pair of regenerators is built at each side of the melting hole or furnace, the heating chamber itself thus standing on an arched vault between the two pairs of regenerators,

B, B. Such furnaces are rectangular in shape, and generally constructed so as to hold from eight to twenty-four crucibles, arranged as a double row in each hole or furnace, and each pot carrying a charge of from 60 to 80 lbs. of metal. Each hole or furnace is covered by three movable segments, D, forming the roof of the same, while the longitudinal walls of the melting chamber incline from the bottom to the top, so that the furnace is about 2 feet wide at the mouth, and 3 feet in width across the bed. With such furnaces 1 ton of steel can be melted

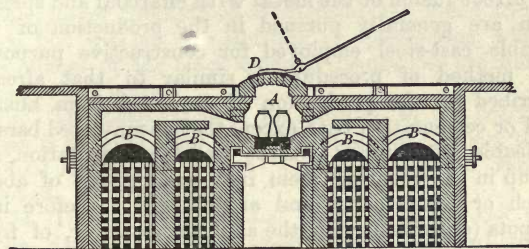

Fig. 85.—Longitudinal Section of the Siemens Regenerative Crucible Steel-melting Furnace.

with about $2\frac{1}{2}$ tons of ordinary small coal, while from five to six heats can be got out in the twenty-four hours; but unless the furnaces are carefully worked, greater loss is suffered from destruction of pots and loss of metal, or from imperfectly melted steel, than occurs with the ordinary furnaces. In some furnaces of this class the arrangement already named, of fixing a lift below the bed of the furnace for elevating it and the crucibles all at once to the floor level, instead of withdrawing each one separately, has been applied.

729. In France, also, small narrow reverberatory furnaces are sometimes employed, into which various numbers of crucibles are inserted for the melting of steel. In these furnaces the fuel is consumed as usual upon a separate grate, but the combustion is promoted

by an atmospheric blast introduced beneath the grate-bars, whilst the draught is provided by a powerful stack.

730. At Pittsburg, U.S., *plumbago crucibles* of a larger capacity than those employed in England are generally used, with charges of about 1 cwt. each,* and the melting is made in furnaces each holding from eighteen to twenty-four pots, and working off five charges in the twenty-four hours, with a consumption of 1 ton of small coal to the ton of steel melted.

731. The methods of producing steel from bar-iron by the direct fusion of the metal with charcoal and spiegel-eisen are generally pursued in the production of the crucible cast-steel employed for constructive purposes. The method of procedure is similar to that already described for the production of cast-steel from blister-steel or cementation bars, except that unconverted bars of malleable iron similar to those used for cementation, are cut up in the shearing room into small pieces of about $\frac{3}{4}$ -inch or 1-inch cubes, and are charged as before into the pots (crucibles), with the addition, however, of from $\frac{1}{2}$ oz. to 8 oz. of charcoal, according to the temper which the steel is required to have ; and subsequently, after the second fire has been worked off, a small quantity of the white highly manganiferous pig-iron known as spiegel-eisen is added. But for the production of the mildest qualities of steel, no direct addition of carbon to the charge is necessary, the desired carburisation being effected entirely by the small addition of spiegeleisen made towards the end of the melting, together with the small proportion of carbon absorbed from the black or plumbago pots in which such metal is melted. The pots in which the fusion of soft steel is made contain considerably more graphite or plumbago, than do the white pots preferred for the fusion of blister-steel and the harder tempers of steel generally. Such plumbago crucibles contain only just sufficient clay to give to the materials employed in their production sufficient

* Sir W. Siemens, F.R.S. ; Iron and Steel Institute, 1877.

cohesion to bear the necessary pressure and manipulation required in the manufacture of the crucibles, and for the movement of the same to and from the furnaces ; but these pots do not require the same care as to annealing before introduction into the melting holes as the white pots already referred to.

732. For the production of a steel that shall *weld* easily to either iron or steel, but which will also sensibly harden by the ordinary methods of heating and cooling, such as is required for the manufacture of certain classes of cutlery, as also for special requirements of the engineer's use, &c., larger proportions of charcoal are added to the charge, but without any addition of spiegeleisen, whilst a few ounces of the black oxide of manganese are added instead of the latter.

733. The charcoal used for addition to the crucible charges is by preference that obtained from the oak, that produced from the softer woods being but rarely employed.

734. The *best crucible steel* is produced by the use of the Swedish bar-iron smelted with charcoal from magnetic iron ores which are practically free from both sulphur and phosphorus, and hence such irons as the Dannemora and Persberg brands, which are of this class, are in request for steel melting purposes, and command correspondingly high prices in the market.

735. Swedish bars are all marked with a distinctive letter, brand, or mark, ceded by the Swedish Government to the owners of certain works, and the use of which brands is also regulated by the Board of Trade. Amongst the Dannemora brands commanding the highest prices may be mentioned the Löfsta iron or "Hoop L" brand, while "double bullet" is another of the first-class Swedish marks. "W and Crown" and "Hoop F" belong to the middle class of these brands, while amongst the commoner Dannemora marks of Swedish bars much used for steel purposes are the "Little S" and "Gridiron" brands.

736. **Wootz** is the name applied to a hard Indian crucible steel, prepared, according to the primitive methods there pursued, by melting about 1 lb. of malleable iron in small unburnt fire-clay crucibles, which are heated in a kind of blast-furnace. About 10 per cent. of fine-chopped wood in the form of the leaves and stems of the *Cassia auriculata*, is added to the metal in the crucibles, while the surface of the charge is then covered over with green leaves of the *Asclepis gigantea*, and the crucible is covered either with wetted clay or with a lid luted on to the pot. After the crucibles have been dried by exposure to the atmosphere, from twenty to twenty-four of them are charged as above and then built in an arched or dome form over the bottom of a small hearth supplied with blast by two pairs of bellows, and to which the fuel (charcoal) is introduced as required. After exposure in such a furnace during from two to three or four hours, the whole is allowed to cool down, when the crucibles are removed and the button or small cake of metal collected in the bottom of each crucible is removed by breaking up the crucible. The cakes so obtained are afterwards heated for several hours before the blast in a charcoal fire, whereby the cakes are raised almost to a welding heat, and are finally drawn down into bars of steel which are usually very hard in temper, and require considerable care in working.

737. Numerous **physics** have been proposed and employed in Sheffield and other crucible-steel producing districts to enable superior cast crucible steel to be made whilst using only inferior Swedish or British bar-irons in its production; but, so far as the author is aware, none of these have been signally successful. Amongst the nostrums so proposed, the addition of which in very small proportions to the crucible charge at some stage or other of the melting process is to produce the result named, are ammoniac chloride, common salt, rock salt, potassic prussiate, potassic chromate, nitre, potassic iodide, and certain fluorides (Henderson process).

Manganese, however, either as the black oxide of manganese, or in the form of spiegeleisen and ferromanganese, is now universally employed with undoubted advantage; whilst alloys of the rarer metals, such as tungsten, chromium, titanium, &c., are somewhat extensively used in the production of special steels, more particularly of the harder tempers required for tools, &c.

738. The use of potassic iodide constitutes the "Sherman process," by which it is expected that the introduction of a few grains of this salt into the crucible charge will, in virtue of the strong chemical affinity existing between iodine, sulphur, and phosphorus, bring about the removal of the latter elements from the metal in the crucibles, with the effect of improving the quality of the steel; but the author has failed to note any decided advantage attending its use, either as to chemical purity or superior behaviour under mechanical tests of the steel so obtained.

CHAPTER XIX.

THE PRODUCTION OF STEEL BY THE DECARBURISATION OF PIG-IRON IN THE FINERY OR THE PUDDLING FURNACE.

739. THE method of obtaining steel by the decarburisation of pig-iron, according to the process as formerly carried on in the *open-hearth fineries* of Styria and Carinthia, produces a material known as "raw steel," which is capable of being applied to many of the useful purposes for which blister-steel is available. The process is not, however, pursued in England, and is only applied to a very limited degree on the Continent.

740. The Styrian method of producing steel in the *open-hearth finery* is conducted in small hearths supplied with blast from a pair of bellows driven by a water-wheel, while charcoal is used as the fuel of the hearth,

and the pig-iron treated is a highly manganiferous iron produced from spathic iron ores. The process is commenced by filling up such a hearth with burning charcoal, when the pig-iron which has been run for the purpose into slabs or plates of some $1\frac{1}{2}$ inch in thickness, is melted before the twyer and falls down during its fusion on to the hearth, whilst during the first stages of the process oxidising materials as hammer-scale and rich slags, are also added to the charge. The pig-iron melts at first quite fluid, but rapidly thickens and becomes pasty under the decarburising influence of the blast and of the highly basic slags with which the molten metal is covered, whereupon another slab of pig-iron is melted before the blast, and, running down upon the pasty metal in the hearth, renders the whole again quite fluid, but, the decarburising action repeating itself, the charge soon resumes its pasty condition, when a third slab is melted before the twyer, as before; but after this and the subsequent additions of pig-iron only the central portions of the mass on the hearth become fluid, with an outer pasty ring surrounding it. In this manner six or eight slabs of pig-iron are successively added, altogether yielding from 200 to 300 lbs. of a spongy iron, which collects on the hearth of the finery, whereupon the slag is run off, and the mass is raised from amongst the charcoal by which it is surrounded, and divided up into wedge-shaped masses, each of which is then drawn down under a hammer with a tup weighing from 5 to 6 cwts. The bars so obtained are very irregular in composition, and require breaking up, assorting, and rendering more uniform by the welding together of the different pieces, when the resulting bars are a second time broken up and re-welded for a like purpose.

741. The Carinthian process differs from the Styrian process just described principally in the increased size of the hearth employed, and the somewhat larger charges of pig-iron operated upon.

742. Puddled steel is the product of a decarburisation

method conducted in a puddling furnace, identical in many respects with that employed for the puddling of malleable iron, and the procedure observed in the production of puddled steel is also similar to that followed where malleable iron is being obtained. The production of puddled steel is somewhat extensively carried on upon the Continent, where it is chiefly employed for the manufacture of bars to be subsequently cut up and remelted in crucibles for the production of cast-steel.

743. The *furnace employed for the preparation of puddled steel* differs from the puddling furnace already described (p. 255) in having a smaller bed, although the grate, flue, and chimney areas are the same or, in other words, the proportion between the area of the grate-bars, &c., to that of the bed is made greater when steel is to be produced; also the depth of fuel upon the bars is increased by the addition of a few inches to the height of the fire-bridge, whereby a greater control over the nature of the flame is possible, and a non-oxidising, neutral, or reducing flame is more readily obtained than with the ordinary furnace, and for the same reason the gas furnaces of Sir W. Siemens are applied with more success to the production of puddled steel than to that of malleable iron.

744. The *furnace charge* usually consists of from 3 to 4 cwts. of pig-iron rich in carbon and manganese, such as the spiegeleisens; but generally mixtures of different classes of irons are avoided as tending to produce irregularities in the product, owing to one portion "coming to nature" before another despite the vigorous rabbling which is always maintained. The charge is broken up into fragments of a tolerably uniform size, and is spread evenly over the bed of the furnace, where the whole is then melted down as rapidly as possible to prevent unnecessary oxidation. During the *melting-down stage*, lasting from forty to fifty minutes, the temperature of the furnace is kept higher than in the ordinary puddling

operation, so that on the completion of this stage the whole should be perfectly fused, and well covered with a fluid slag. The oxidation of the carbon and the uniformity of the product are largely influenced by the condition of the slag, and hence the necessity in this process of using a manganiferous pig-iron, since the manganese whilst contributing to the fluidity of the cinder, also diminishes its decarburising influence. At the conclusion of the melting-down period the damper is closed, and the temperature reduced so as to prevent the fining from going on with too great rapidity; but, as the charge thickens and rises, the damper is carefully raised to keep the charge fluid, while repeated and vigorous stirring or rabbling of the charge beneath the fluid cinder, is effected, and after from thirty to forty or fifty minutes floating granules of metal begin to appear, and the *boiling stage* ensues, whereupon the chimney damper is again closed, and the hearth is filled thereby with a non-oxidising atmosphere and flame which prevents the decarburisation of the charge from proceeding with too much rapidity. The temperature of the furnace gradually falls during the boiling stage, and during this period also, and more especially towards the close of the process, a poor, very fluid, and but slightly oxidising slag is required, since, if the slag be too viscous and highly oxidising, then the decarburisation of the charge proceeds with too great rapidity, and the quality of the product is deteriorated.

745. Throughout the boiling and fining stage the same state of effervescence or ebullition due to the escape of jets of carbonic oxide from the bath of metal, is observed as that which takes place when malleable iron is the object of the process; but in the present case the decarburisation of the metal on the bed of the furnace is stopped at an earlier period than when malleable iron is to be produced. The appearance of the particles, or granules of metal brought to the surface of the cinder or slag during the rabbling of the boiling stage, indicates

the progress of the process, as well as the nature and quality of the final product; for when the furnace is working satisfactorily, the granules appear brilliant in lustre, white and granular, yielding probably a fine-grained steel of good quality; but if the particles are coarsely granular and flaky, then the steel is usually coarsely granular, imperfectly refined, and of inferior quality.

746. The *boiling and fining stage* usually occupies from twenty to twenty-five minutes, after which the "balling" of the charge commences; this is an operation demanding care and practical skill on the part of the workman, and according to requirements the charge is either all balled at once into a single ball, or it is divided into smaller portions or balls.

747. The *balling of the charge* is effected with the damper down, and the furnace is thus filled with a non-oxidising smoky flame, so that all decarburisation is stopped during this stage of the process, and the temperature is also kept lower than during the corresponding period in the puddling for malleable iron.

748. The *shingling of the puddled balls* is effected as quickly as possible, and at a lower temperature than that employed in the shingling of the puddled balls of malleable iron; but more care is required in the earlier stages of the shingling or hammering of the metal, especially if the temper of the steel be hard, since the puddled balls are not so solid, and hence require lighter blows at the commencement than are permissible when the product is malleable iron.

749. The *chemical reactions* involved in the puddling of steel are essentially the same, or are strictly analogous to those already detailed as occurring in the puddling furnace for the production of malleable iron. Puddled steel shows a considerable decrease in the proportion of the carbon, sulphur, phosphorus, silicon, and manganese present in the pig-iron from which it is produced, as is indicated by the accompanying analyses, published by Schelling, of the original pig-iron, the steel puddled there-

from, and of the slags produced during the process, as carried on in a gas-furnace at Zorge, in the Hartz, working upon a mixture of white with grey pig-iron.

ANALYSES OF PIG-IRON, PUDDLED STEEL, AND SLAGS FROM THE PUDDLING FURNACE.

	Original pig-iron.	Puddled steel.		Slags at end of the process.
Graphite	0·08	—	Silica	20·52 per cent.
Dissolved or combined carbon }	2·60	0·94	Phosphoric anhydride }	5·25 "
Sulphur	3·09	trace	Ferric oxide	6·24 "
Phosphorus	0·48	0·075	Ferrous oxide	62·14 "
Silicon	0·99	0·11	Alumina	3·00 "
Manganese	2·01	0·27	Lime and Magnesia	1·50 "

750. The conduct of the process, as above described, is practically the same as the pig-boiling process (p. 261), except, that for the production of puddled steel, the decarburisation or fining of the pig-iron is effected more slowly although less completely than in pig-boiling; thus the process for the production of puddled steel lasts from one hour and fifty-five minutes to two hours and fifteen minutes, permitting of only five or six charges being worked off during the twelve hours; while the puddling or pig-boiling process for the production of malleable iron, usually lasts only from one hour and thirty-five minutes to one hour and fifty-five minutes per charge when working the usual charges in single furnaces, or between six and seven charges are worked off during the day of twelve hours. The *consumption of fuel*, also, which ranges between 20 and 25 cwts. of coal to the ton of malleable iron produced, reaches to 25, 30, or 35 cwts. of the same coal for the production of a ton of puddled steel; but the use of the Siemens gas furnace in the puddling of steel is attended with a considerable economy in fuel; the metal produced, however, is said to be less homogeneous, from the presence of intermixed cinder, necessitating re-melting, whilst the metal also welds very imper-

fectly. The loss of weight between the puddled steel bar and the original pig-iron is between 6 and 9 per cent., or, as might be expected, slightly less than when malleable iron is produced.

751. The slag or cinder from the puddling of steel, is more fluid, is less rich in iron and is consequently less decarburising than the cinder occurring in the corresponding stages of the puddling of malleable iron. For maintaining this condition of the slags such materials as quartz, clay, mill-cinder, poor slags, &c., are added to the furnace during the melting-down stage; and for still further promoting the fluidity, &c., of the cinder, black oxide of manganese is sometimes added before balling up the metal.

752. As in the crucible steel processes, so also in the puddling of steel, the use of various *physics* for the elimination of sulphur and phosphorus from the charge have been proposed and tried. Of such are potassic chromate, potassic ferrocyanide, and other cyanogen compounds or mixtures containing carbon; but a more general physic sometimes employed in this process is *Schafhäütl's powder*, which consists of a mixture of black oxide of manganese, common salt, and potter's clay. It is added at intervals during the rabbling of the charge, and before the balling up.

753. The shingled blooms of puddled steel are reheated either in the hollow fire or in the balling furnace before either tilting under the hammer, or rolling into bars.

754. Mr. Riepe, under whose patent the production of puddled steel was formerly carried on at the Mersey Steel and Iron Company's works, and at the Low Moor Ironworks, proposed to work upon less than the usual charges of pig-iron, and so he introduced only about $2\frac{1}{2}$ cwts. of metal at each heat. The patentee also appeared to attach considerable importance to the working of the furnace at the lowest possible temperature, for which purpose, as the metal melted, the damper was partially

closed ; and afterwards twelve or fourteen shovelful of forge or mill-cinder were added, and the whole carefully melted down, after which the molten metal was worked with the addition of a small quantity of a mixture of black oxide of manganese, common salt, and clay, all ground together. After the lapse of some minutes the chimney damper required to be raised, and about 40 lbs. of pig-iron was placed near the fire-bridge upon a bed of coke put there for the purpose, so that when the bath began to boil and the pig near the bridge was trickling down into it, the whole of the pig-iron was then raked down into the bath of metal and the mixture well incorporated, whereupon boiling commenced, jets of carbonic oxide issued from the surface and grains of steel began to appear through the surface of the cinder ; the damper was then partly closed and the rabbling continued, the jets of carbonic oxide gradually disappearing as the metallic grains collected together, and the whole mass assumed a pasty consistency. The charge was then balled up into several balls, the portion not forming the first balls being kept well covered with cinder, and it was said that if the temperature was maintained too high throughout this stage, the charge afforded less uniform results, and much of the metal passed into the condition of malleable iron. The balls were subsequently shingled and worked into bars as usual.

755. Amongst other processes for the partial decarburisation and elimination of silicon, sulphur, and phosphorus from pig-iron with the production of steel thereby, are the chemical methods of refining proposed by Mr. Heaton and Mr. Henderson.

756. The Heaton Process, known also as the *nitrate process*, is a refining operation in which *sodic nitrate* instead of atmospheric air is employed as the refining agent. The operation is conducted in a circular cupola or converter, formed of iron plates lined with fire-brick or fire-clay and fitted with a movable bottom

secured to the body of the cupola by iron clamps. Into this bottom is introduced the charge of 10 or 12 lbs. of sodic nitrate to the hundredweight of metal to be refined, and this is covered with a perforated cast-iron plate to prevent its floating upwards as the fluid cast-iron is subsequently run into the converter, whilst a little silica (sand) and air-slacked lime are also sometimes added along with the nitrate.

757. The sodic nitrate being thus charged into the bottom of the converter and secured in position by the perforated plate just mentioned, the molten pig-iron is then run in from above through a spout provided for this purpose, and in about two minutes brown nitrous fumes begin to appear within the converter, followed by blackish grey and then whitish fumes, but it is only after some five or six minutes that the cast-iron perforated plate is melted by the fluid pig-iron, whereupon a violent reaction immediately ensues, accompanied by an active state of ebullition in the metal and the emission of a bright yellow sodium flame from the chimney or top of the cupola. After continuing for about $1\frac{1}{2}$ minute the ebullition ceases and the metal settles down, whereupon the bottom of the cupola is detached, and removed upon a truck placed beneath the converter. The *crude steel* and slag are then poured or turned out on to the floor, since the metal is not sufficiently fluid to permit of its being directly cast into ingots.

758. The crude steel so obtained is broken up and the pieces are subjected to sundry pilings, reheatings, and shingling into blooms, which are again cut up and again reheated for rolling into bars; or, instead of piling and shingling into blooms as just mentioned, the crude steel is at once hammered into blooms or flat cakes, which are broken up into small pieces, sorted carefully, and then melted in crucibles for the production of cast-steel in the ordinary manner. The process yields, however, a very irregular product, and is not carried out on a manufacturing scale.

ANALYSES OF PRODUCTS, &C., OF THE HEATON PROCESS.

	Pig-iron introduced into cupola (Miller).	Hard crude steel (Miller).	Hard crude steel (Snelus).	Soft crude steel (Miller).	Soft crude steel (Snelus).
Carbon . . .	2·830	1·800	2·061	·993	1·098
Silicon with a little titanium)	2·950	·266	·014	·149	trace
Sulphur . . .	·113	·018	trace	trace	trace
Phosphorus . .	1·455	·298	·489	·292	·344
Arsenic . . .	·041	·039	—	·024	—
Manganese . .	·318	·090	·064	·088	·072
Calcium . . .	—	·319	—	·310	—
Sodium . . .	—	·141	—	—	—
Metallic iron .	92·293	97·026	—	98·144	—

759. From these analyses it is obvious that the process effects a partial refining of the pig-iron, whereby there is a material decrease in the proportion of carbon, but the sulphur and phosphorus are only partially eliminated, whilst silicon is present only in small proportions in the crude steel produced by this process.

760. The Henderson or Fluorine process, like the last described, is a fining process intended to produce malleable iron or steel from inferior or Cleveland pig-iron, by the decarburisation and separation therefrom of silicon, sulphur, and phosphorus under the influence of fluorine liberated from a bed of fluor-spar spread upon the hearth of a puddling furnace, and upon which is placed a titaniferous pig-iron produced by the fusion of about 20 cwts. of Cleveland pig-iron with some 7 cwts. of Norwegian titaniferous iron ore. By the fusion of such a charge upon the bed of a puddling furnace prepared as above, the silicon, sulphur, and phosphorus of the pig-iron are partially eliminated. It is claimed that 80 per cent. of the phosphorus in the pig-iron escapes in a vaporous form, and that only the remainder passes into the slag, which is thus, unlike the ordinary puddling-furnace cinder, not too phosphoric to permit of its use in the blast-furnace.

The operation is entirely completed by working the charge under a layer of slag, and no stirring or rabbling is necessary during the conduct of the process, the only manual labour after charging being that of balling-up the charge.

761. A simpler modification of the Henderson process consists in mixing at once the finely ground fluor-spar with titaniferous iron ores upon the bed of the puddling furnace, and charging thereupon about $4\frac{1}{2}$ cwts. of pig-iron; after which the furnace is closed to prevent the admission of air, and the temperature is raised as high as possible. Under these conditions the mixture of fluor-spar and titanic iron-ore on the bed of the furnace only assumes a pasty condition, which is favourable to the slow decomposition of the calcic fluoride (fluor-spar) by the silicon and other elements of the pig-iron. The heat generally lasts about ninety minutes, but after about seventy minutes from the time of charging the sampling of the bath commences, and is continued every few minutes until the process is judged to be complete. As in the previous modification, there is no stirring or rabbling of the charge.

762. Of the methods for the *production of steel by the fusion of pig-iron with rich ores or oxides of iron*, the most important is the Siemens open-hearth direct process (p. 456). The Uchatius process, although pursued in Sweden with some measure of success for the treatment of pig-iron with the magnetic iron ores of Bispberg, has been discontinued in England, owing largely to the want of uniformity in the product obtained. It consists in the production of a crude steel by the partial decarburisation of pig-iron, by fusing the latter along with materials capable of yielding oxygen, such as ferric oxide, roasted iron ores, &c. The pig-iron is first melted in a cupola, and is then granulated either by running the molten metal into water or by other suitable methods, after which a mixture is made of the granulated pig with 20 per cent. of its weight of the roasted and pulverised spathic iron ore or oxide of iron,

with a little black oxide of manganese, and about 4 per cent. of its weight of fire-clay; such a mixture is then charged into clay crucibles and melted in an ordinary furnace, under which treatment the ferric oxide suffers reduction by the carbon of the pig-iron with the evolution of carbonic oxide, and a proportionate decarburisation of the pig-iron to the condition of steel is the result. If the softer welding tempers of steel are to be produced, then, in addition to the above mixture, a small quantity of malleable iron is added to the crucible charge, while harder tempers are obtained by the addition of charcoal. The yield of cast-steel from the crucibles is usually some 6 per cent. in excess of the weight of the pig-iron employed, and generally the finer the granulation of the pig-iron the milder is the temper of the steel produced.

763. A modification of the Uchatius process goes under the name of the **Ellerhausen process**, but it differs from it in the manner of mixing the pig-iron with the oxidising materials, such as powdered hæmatite, iron sand, or powdered magnetite; thus, instead of the granulation adopted in the Uchatius process, the mixture of pig-iron and decarburising materials used in the Ellerhausen process is effected by running simultaneously the fluid metal from the blast furnace and the iron ores as above, into a series of moulds placed on a revolving table. The pig-blooms so produced are melted and puddled upon the bed of a puddling furnace, yielding iron or steel according to the method of puddling and consequent degree of decarburisation effected, but, as in the Uchatius process, and in all other methods of producing steel by the fusion of mixtures of pig-iron and oxidising agents, such as iron ores, arsenious anhydride, nitre, &c., the product is irregular in temper and quality, and these processes do not, therefore, meet with favour in England.

764. The *production of steel by the decarburisation of pig-iron by the Siemens open-hearth process* is described in the next chapter (p. 456.)

CHAPTER XX.

PRODUCTION OF STEEL BY THE FUSION OF PIG-IRON WITH MALLEABLE IRON OR WITH IRON ORES IN THE OPEN-HEARTH STEEL-MELTING FURNACE.

765. THE methods of producing steel in the open-hearth regenerative furnace of Sir W. Siemens are divisible into three classes, according as iron ores are added to the furnace charge or otherwise. Thus steel is produced on the large scale in this furnace: 1st, By the fusion alone of a mixture of pig and scrap-iron or scrap-steel constituting the Siemens-Martin process; 2nd, by the treatment of pig-iron with certain classes of iron ores without the addition of scrap, according to the direct open-hearth process of Sir W. Siemens; and 3rd, by a combination of the two processes according to which pig-iron, iron or steel scrap, and certain pure iron ores are treated in the same furnace. Whilst the first is the more generally pursued on the Continent, the third process is preferred in England, and latterly it has become customary to designate the steel made by any of the above modifications as "open-hearth steel." The open-hearth processes are under better control than the Bessemer, since ample time is afforded by them for the testing of the metal, and for the addition of such proportions of pig-iron or of iron ore as are required, so as to yield a more or less carburised product according to requirements.

766. The open-hearth steel-melting and regenerative gas furnace generally employed in these processes enables the highest temperatures to be attained without requiring a strong draught or inducing a cutting flame. The furnace resembles in its general arrangements the reheating furnace (p. 371), and, like it, is constructed with two pairs of regenerators, A, A, G, G (Fig. 86), built transversely beneath the furnace bed, and it is provided with a

reversing gas valve, *g*, and air valve, *a* (Fig. 87), similar in construction and action to those already described, except that, a higher temperature being required in the melting furnace, the several valves and also the heating surface of the regenerators, are made proportionately greater. *u* (Fig. 87) is the gas culvert, whilst *v* is the flue leading to the chimney. Above the regenerators is the furnace, with its hearth supported upon cast-iron plates, *b, b* (bath-plates, Fig. 86), between the under-side of which and the top of the regenerator chambers air is free to circulate for the cooling of the bottom. The plates are lined with a single thickness of fire-brick, and above this is made the bottom of quartzose or other refractory sand, introduced, when the furnace is hot, in layers about 1 inch thick, each layer being rammed down gently and partially vitrified or glazed before the next one is applied, a total depth of from 14 or 16 inches of sand being in this manner introduced. The bottom so prepared requires repairing and levelling after each heat, and before introducing the succeeding charge, by placing fresh sand in the holes or pits left in the bottom when the metal has been tapped out. The ordinary bed is formed of siliceous sand, as just described, but *basic linings* have been tried and used successfully in Austria, France, and in England for rendering the process a basic one for the treatment of phosphoric pig-iron if required; while in some of the Continental furnaces working the ordinary Siemens-Martin process, the bottom is also formed of a mixture of clean sand and burnt quartz in equal proportions, incorporated with 15 per cent. of fire-clay.

767. The hearth, *h*, is regular in form, and slopes from all sides towards the tap-hole, *p*, situated at the back, below the middle working door. At the front side of the furnace are three doors, of which the two side ones are principally used for introducing the charge of pig-iron and scrap, whilst the central one is a little lower than the other two and forms the working-door through which the ore or other additions of pig or scrap required during the

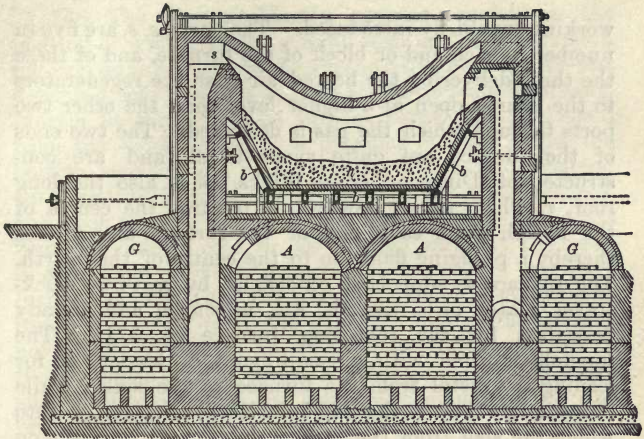

Fig. 86.—Longitudinal Section of the Siemens Open-Hearth Steel-Melting Furnace.

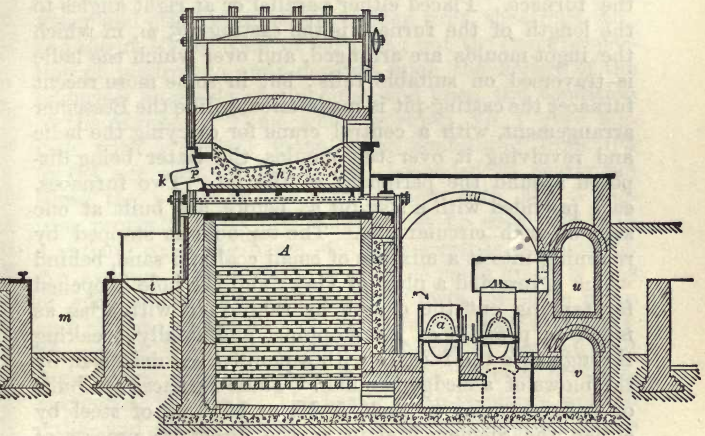

Fig. 87.—Cross Section of the Siemens Steel-Melting Furnace.

working are chiefly introduced. The ports, *s, s*, are five in number in each end or block of the furnace, and of these the three delivering the heated air from the regenerators to the hearth open at a higher level than the other two ports through which the gas is delivered. The two ends of the furnace are quite symmetrical, and are constructed of Dinas or silica bricks, as is also the long roof, *r*, which slopes downwards towards the centre of the hearth from each end of the furnace, and directs thereby a plunging flame on to the centre of the hearth. The furnace is supported externally by cast-iron buckstaves, plates, rails, tie-rods, &c., as shown and already described for the reheating furnace (p. 371). The tap-hole is fitted with a small spout or lander, *k*, for leading the metal from the furnace to the ladle; while immediately below the tap-hole is the *slag-pit*, *t*, into which the slag from the furnace is allowed to drain on the withdrawal of the ladle from beneath the spout after the whole of the molten metal of the charge has run from the furnace. Placed either parallel or at right angles to the length of the furnace is the casting-pit, *m*, in which the ingot-moulds are arranged, and over which the ladle is traversed on suitable rails; but in some more recent furnaces the casting-pit is made circular like the Bessemer arrangement, with a central crane for carrying the ladle and revolving it over the moulds, the latter being disposed around the periphery of the pit. Two furnaces, each provided with a slag-pit as before, are built at one side of such circular pits. The tap-hole is stopped by ramming into it a mixture of small coal and sand, behind which is inserted a plug of clay; and the hole is opened for tapping out the charge by raking out with a bar as much as possible of the stopping, and finally breaking through into the furnace with a pointed bar driven in by the blows of a sledge hammer. These furnaces are built of sufficient size to melt 5, 10, or 15 tons of steel by either the Siemens-Martin or the direct-ore process of Sir W. Siemens.

768. The Siemens-Martin process consists in the melting of wrought iron or scrap steel in a bath of molten pig-iron on the hearth of the regenerative gas furnace last described, and was first used on the large scale by Messrs. Martin at Sireuil. The furnace being already heated from the working off of a previous charge, it has the bottom levelled and repaired, after which it is charged with pig-iron, introduced towards the ends of the furnace, and upon this pig-iron the scrap is placed, the materials being all charged cold, or, as on the Continent, the scrap is sometimes previously heated to redness in auxiliary furnaces arranged for the purpose. Grey hæmatite pig-iron of Bessemer quality is generally used, although it is not necessary that it be quite so grey as that used in the Bessemer process, hence a large proportion of white and mottled pig-iron is frequently employed in this process.

769. The *charging is effected* by first introducing on to the hearth from 15 to 20 per cent. of pig-iron, upon which is placed about 66 per cent. of scrap steel made up of Bessemer and other clean scrap, broken rails, shearings, &c., and about 15 per cent. of old rails; but the exact proportion of pig-iron to scrap depends upon the nature of the materials available at the time, and upon the condition of the furnace. Thus, when working No. 1 grey pig-iron with a neutral flame, scrap containing from 0.3 to 0.4 per cent. of carbon can be added to nearly ten times the weight of the pig-iron, but with No. 3 pig-iron proportionately less scrap must be used, and with a cutting oxidising flame still less scrap is permissible. An average charge for tyre metal is made up of 8 tons of good steel scrap with about 8 cwts. of ladle scrap and 13 cwts. of pig-iron, to which from 1 cwt. to $1\frac{1}{2}$ cwt. of spiegel is added after the charge is melted, and just before tapping from $\frac{3}{4}$ cwt. to $1\frac{1}{2}$ cwt. of ferromanganese is added. The heavy scrap is placed near to either end of the hearth, so as to be heated to whiteness before rolling it into the bath of cast-iron upon the bed

of the furnace, and in from three and a half to four hours after charging, the whole contents of the furnace will be melted, an oxidising flame having been maintained throughout, and the course of the current of gas and air having been reversed during the same period at intervals of thirty minutes. After complete fusion is effected, samples of the metal in the furnace are withdrawn from time to time in a small ladle, and hammered and broken to test their malleability, toughness, and to examine the nature of the fracture of the metal, while a chemical analysis is also rapidly made to ascertain the percentage of carbon in the metal of the bath; when the tests indicate that a sufficiently low temper has been attained by the metal, then about 1 per cent. of spiegel of from 8 to 15 per cent. content of manganese, along with about 3 per cent. of a ferromanganese containing from 60 to 80 per cent. of manganese, is added through the side doors of the furnace. A few minutes suffice to melt this, during which the fluid metal is stirred or rabbled to thoroughly mix it, after which the metal is tapped out as quickly as possibly to prevent the loss of too much manganese in the slag.

770. The *tapping* is effected, as before mentioned, by driving a pointed bar through the tap-hole into the bath of metal, so that on withdrawing the bar the steel follows it, and flows into a ladle carried in a carriage upon wheels. The ladle is fitted with a plug or goose-neck stopper like the Bessemer ladle (Fig. 92), and from it the metal is run out into the several moulds, which are each "stoppered" as quickly as possible either with an iron plate, or simply by throwing on a shovelful of sand, which is then covered with an iron plate, wedged down upon the sand by the insertion of a wedge beneath two lugs cast for the purpose in the top of the ingot-moulds.

771. A 7-ton furnace, working charges as above, will make sixteen or eighteen meltings per week, thus working off a heat in about six and a half or seven hours, while one and a half hours will be occupied in repairing the

furnace bottom, tapping out the metal, heating up and recharging the furnace. The operation of casting the charge into ingots each of sufficient size to roll into a double length of rail occupies some ten or twelve minutes. The *number of charges worked off* in the week, however, will obviously vary with the temper of the metal produced, and upon the condition of the furnace; with softer metal the heat will be longer, and fewer charges therefore will be worked off than when harder tempers are being melted.

772. Rails prepared from a charge made up as above will contain from 0·3 to 0·4 per cent. of carbon, from 0·08 to 0·10 per cent. of phosphorus, from 0·45 to 0·65 per cent. of manganese, and traces only of silicon, the original pig-iron employed for the charge containing 3 per cent. of carbon, 0·078 per cent. of phosphorus, 0·035 per cent. of sulphur, with 1·9 per cent. of silicon.

773. The *average life* of a furnace working the Scrap or Siemens-Martin process is about 232* charges, although the roof will require partial renewal after working off about 150 charges or less.

774. The *loss of metal* in the Siemens-Martin process is from 5 to 8 per cent. of the combined weight of the pig-iron and scrap charged, while the saving in fuel and labour over other steel processes is considerable, besides which it utilises the large quantities of Bessemer and other steel scrap produced in the mills, &c.

775. The "Pernot gas-furnace," with revolving hearth mounted on wheels so as to rotate in a plane inclined at an angle of about 6° with the horizontal as described (p. 297), is employed in France and other places upon the Continent, for the production of Siemens-Martin steel. The hearth or bed of the furnace then makes from three to four revolutions per minute, and yields during the twenty-four hours from three to four taps of mild steel, or from four to five casts of the harder tempers, each cast weighing about 8 tons, while with the larger

* *Jernkontorets Annaler*, 1882.

20-ton furnaces two taps per day are obtainable. The usual charge for these furnaces is about 8 tons of metal made up of one-fifth of good hæmatite pig-iron and four-fifths of steel scrap, formed chiefly of the crop-ends of rails; and the scrap is heated to redness in an auxiliary furnace before introduction into the Pernot furnace. The scrap and pig-iron having been introduced, fusion of the charge very rapidly ensues, and, owing to the inclined position of the revolving hearth, nearly one-half of the bed of the furnace is always exposed to the heat and flame of the gases, thereby preventing the surface of the bed from becoming cold and chilling the metal in contact with it. The scrap is carried partially around as the hearth revolves, and is constantly sliding back or over into the molten pig-iron lying at the lowest level, in which manner a more rapid fusion of the charge is promoted than upon the fixed hearth. The circular hearth in an 8-ton furnace measures about 7 feet in diameter, but it attains to nearly 14 feet in diameter in a 20-ton furnace, and has a depth of bath of some 8 or 9 inches.

776. Ponsard also endeavours, in the "Forno convertisseur Ponsard," to apply blast to the Siemens or Siemens-Martin process, and so to increase the output of each furnace by diminishing the time required to work off each heat, whilst at the same time securing the advantages of being able to test or sample the metal after the manner of the Siemens process, thereby ensuring the greater uniformity characteristic of the latter metal with some of the rapidity of conversion presented by the Bessemer process. For this purpose, the first part of the operation, during which a blast of air is passed through the fluid metal, is conducted as rapidly as possible, after which the hearth is turned round so as to close or shut off the blast, and the process is then continued to completion after the manner of the Siemens process.

777. The Ponsard furnace, already described (p. 380), has a circular, movable, and inclined hearth, mounted

on wheels, and which can be turned through half a revolution upon an inclined axis. A, A, G, G (Fig. 88) are the air and gas regenerators respectively. The furnace is fitted with the usual arrangement of valves,

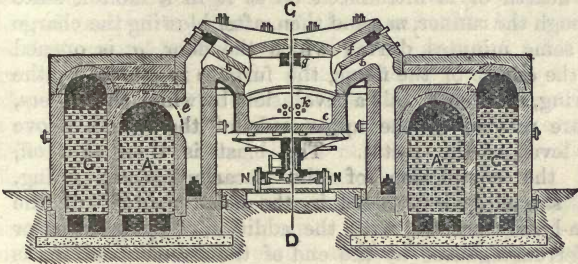

Fig. 88.—Vertical Section of the Ponsard Steel-Melting Furnace.

&c., for reversing the direction of the current of the air and gas, the latter passing from the *producers*, through the *regenerators*, G, to the *hearth*, c, by the *port*, b, where it meets with the heated air required for its combustion; the air having ascended on its way to the furnace through the *regenerator*, A, along the *flue*, e, to the *air port*, f, while the flame and products of combustion pass away from the hearth, c, through the regenerators at the opposite end of hearth, and thence to the chimney.

778. As previously noted, this furnace has been applied with re-

ported success to a sort of combined Siemens and Bessemer arrangement for the production of steel, for which purpose a blast of air is conveyed to a chamber, d, in the bottom of the spindle or axis, upon which the

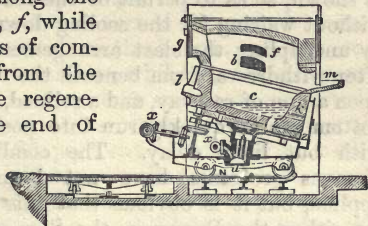

Fig. 89.—Transverse Section of the Ponsard Furnace on line c d (Fig. 88).

hearth rotates, and is from thence conveyed by a pipe to a twyer box, *z*, from which three or more twyers open into the bath of metal, as shown in the cross section (Fig. 89). The charge of pig-iron is either melted on the hearth or is introduced on to it in a molten state through the runner, *m*; and then, after blowing the charge for some minutes, during which the door, *g*, is opened for the escape of the flame, the furnace is rotated by the gearing, *x*, through half a revolution, by which the twyers, *k*, are rotated to the upper side of the hearth above the level of the metal. The blast is then shut off, and the completion of the decarburisation, fining, and sampling is pursued in the usual manner of the open-hearth process, with the addition of spiegeleisen or of ferromanganese at the end of the decarburisation, as in the ordinary open-hearth process. The metal is tapped out into the ladle from the *tap-hole*, *b*, which now occupies the lowest position in the bed of the furnace, and is placed opposite to the spout, *m*, by which the fluid metal is introduced. The furnace is supplied with gas from gas producers of the ordinary construction. The hearth or bed, *c*, also can be withdrawn upon the carriage, *n*, as shown, so as to permit of the ready repair of the roof without waiting for the cooling down of the same, whilst by uncoupling the blast arrangements the whole hearth after withdrawal from beneath the roof, can be run away upon a line of railway, and a relined, or repaired and dried bottom can be quickly run into position under the roof with but little delay. The combined Bessemer and Siemens processes have not been as yet generally applied, but it is obvious that this furnace is available for either the Bessemer, the Siemens, or the combined processes of Bessemer and Siemens, as above described.

779. The combined open-hearth and Bessemer process is conducted in Styria by first running the pig-iron from the blast furnace into the Bessemer converter, and there partially decarburising it by blowing air through it; but before complete decarburisation is effected the metal

is poured from the converter into a ladle, and is then conveyed to a fully-heated Siemens furnace, where it boils during some three or four hours, and at intervals additions of malleable iron and scrap steel altogether equal to 4 or 5 per cent. of the charge, are made, until finally, when the desired temper or degree of decarburisation has been reached, some 5 or 6 per cent. of spiegeleisen and a little ferromanganese are added. The combined process is best adapted to the production of the harder classes of steel; it requires, however, careful manipulation, and its success depends largely on being able to maintain the boil in the Siemens furnace during the entire refining period.

780. Attempts have been made to shorten the open-hearth process by blowing air or steam into the bath of molten metal during the earlier stages, for which purpose a hollow rabble conveying air or steam into the bath is inserted through the furnace door; but these processes are not at all of general application. The combined process as pursued at Ruhrort, is effected* by introducing the blast through twyers formed of iron tubes covered with fire-clay, and each bent over at the end so as to form a nozzle of about one inch in diameter, with three blast outlets in each nozzle. Three of these twyers are introduced horizontally into the furnace, and then turned downwards so as to dip into the molten metal on the hearth, and thus to deliver the blast below the surface, whilst the three twyers are joined outside the furnace into one pipe, connected by a flexible tube with the blast supply. At Ruhrort, the charge consists of 35 per cent. of white iron, with 65 per cent. of scrap, which are melted in the Siemens furnace, and then blown for fifteen or twenty minutes by an arrangement as above, with blast at a pressure of about 12 lbs. per square inch. The temperature of the bath rises much higher than in the ordinary Siemens-Martin process, and occasionally necessitates the addition of cold rail ends or other scrap to the bath.

* Prof. Kupelwieser : *Oest. Zeitschrift für Berg- und Hüttenwesen*, 1882.

The operation of blowing is also attended with the escape of brown fumes from the surface of the bath.

781. The Siemens open-hearth process, in which pig-iron, steel scrap, and the purer hæmatite *iron-ores* are employed, is generally preferred in England to the scrap process alone, although there is no special necessity for the use of scrap in the process, except that it is a convenient mode of using up the large proportion of scrap of various kinds, such as crop ends of rails, bars, shearings, &c., largely produced in all steel works.

782. The open-hearth process is conducted in the Siemens regenerative steel-melting furnace, described p. 445, and into the heated furnace the charge of about 30 per cent. of hæmatite pig-iron, with 70 per cent. of steel scrap, is introduced. The pig-iron is first introduced and distributed over the bed of the furnace, when the scrap is placed upon it, and after complete fusion of the charge, Spanish or African rich hæmatite iron-ore in lumps is added at intervals for the decarburisation of the bath of metal. In this manner during the working of an 8-ton charge of metal, from 25 to 28 cwts. of ore will be added, each addition of ore being followed by a state of violent ebullition or boiling of the metal on the furnace hearth. Samples of the metal are withdrawn from time to time, and are tested for malleability, for toughness, and for carbon, as described for the Siemens-Martin process, whilst ore or pig is added from time to time, according as further decarburisation or increased hardness is required. When the desired degree of softness has in this manner been attained, the metal is allowed to stand for a short time in the furnace, to clear itself of slag, and small quantities of limestone are also added during the process if the covering of slag be insufficient, its addition also throwing down a proportion of iron from the slag, which otherwise would pass away unreduced and be lost. Spiegel, or ferromanganese, or a mixture of these, is added at the end of the process, in the same manner as in the conduct of the Siemens-Martin process; or for the

production of very soft metal, where only from $\frac{3}{4}$ cwt. to $1\frac{1}{4}$ cwt. of ferromanganese is required for the recarburisation of an 8-ton charge; the ferromanganese is often first heated to redness and then added direct to the metal in the ladle as it runs from the tap-hole of the furnace.

783. In the Siemens process the *yield* often exceeds by from 1 to 2 per cent. the combined weights of the pig-iron and scrap introduced into the furnace, since in the decarburisation of the pig-iron a proportion (probably amounting to about one-half) of the ore which is added suffers reduction, and the metal so separated passes into the steel and increases the yield.

784. The *duration of the open-hearth process* where iron-ores are employed is from nine to eleven or twelve hours when working upon 8-ton charges, and is thus somewhat longer than the scrap process, while the hearth is also more strongly attacked by corrosion than in the last-mentioned process. The methods of tapping the furnace and casting of the metal into ingots are the same as in the Siemens-Martin process. The moulds, also, and the arrangements for casting described under the Bessemer process, are also available for, and are used in this process.

785. One block of four ordinary Siemens gas-producers will yield gas sufficient for an 8-ton melting furnace, and the consumption of coal in the process varies from 10 to 14 cwts. per ton of metal produced, according to the quality of the coal and temper of the steel to be produced.

786. The *Siemens open-hearth*, like the Bessemer process, proceeds by first *decarburising* the bath of molten metal, and then *recarburising* it by the addition of spiegel-eisen, ferromanganese, or other highly manganiferous alloy of iron, &c. This addition obviously introduces at the same time a small proportion of other impurities, like sulphur, silicon, phosphorus, &c., into the steel; but this result is now minimised by the almost universal use of ferromanganese as the recarburising material, whereby

a smaller weight of the recarburising alloy is required for the introduction of sufficient manganese into the steel to prevent the red-shortness otherwise manifested by the metal, and to improve its malleability, without at the same time introducing too much carbon and such impurities as attend the use of the larger amounts of spiegeleisen; and the use of ferromanganese is therefore especially necessary in the production of soft or mild steel. One advantage of the open-hearth process is that the steel can be quite *dead melted*, the process not being limited as to time, since the nature of the flame and the temperature of the furnace are so much under control that the bath of fluid metal, after having been reduced to the lowest degree of carburisation required, may stand comparatively unaltered for any reasonable period, during which time samples may be taken for testing as required, and additions of pig-iron, wrought-scrap, spongy metal or iron-ore made to adjust it to the desired temper and quality, whilst spiegeleisen or ferromanganese can be added in the solid condition immediately before casting in the required proportion, with the obtaining of a product (steel) of which almost the exact composition is known before casting.

787. In the open-hearth methods of producing steel the *decarburisation* and the separation of *silicon* and *manganese* from the pig-iron of the charge, do not appear to progress with the regularity which occurs in the Bessemer converter. During the first period or melting down of the charge in the Siemens furnace, the carbon, silicon, and manganese are each more or less oxidised, so that at the end of this stage about 50 per cent. (the proportions varying with the temperature of the furnace) of these elements has been removed. After the charge is melted down, however, the metal remains tranquil in the bath, undergoing little, if any, decarburisation, until the whole of the manganese has been oxidised, and the silicon in the molten metal has been reduced to about .02 per cent.; this condition is attained in from three to four hours, after

which the bath of metal *begins to boil* from the escape of carbonic oxide, resulting from the oxidation of the carbon, and this state continues until the carbon is reduced to about 0·1 per cent. or under, at which point the bath again becomes tranquil, and the slag, which thirty minutes previously was of a brownish colour, begins to blacken, owing to the slight oxidation of iron now going on.

788. Haematite pig-iron containing but small proportions of sulphur or phosphorus is used for the open-hearth processes, since practically the whole amount of the two elements just named remains in the finished steel, unless the hearth be specially prepared of a *basic* character, as by the use of bauxite and magnesian bricks, or of a mixture like calcined dolomite and anhydrous coal-tar, which mixture under the heat of the furnace, yields a hard, basic, refractory lining. By conducting the open-hearth processes upon such a lining, with the addition at short intervals of a small proportion of lime and iron ore to the charge, a highly phosphoric and basic slag is produced during the working, which, owing to the excess of lime present, removes the silicon completely, and the phosphorus almost totally, so that a steel is obtained practically free from phosphorus. As conducted at Creusot, a 15-ton charge of pig-iron and common iron scrap, refined under a current of gas as in the ordinary Siemens-Martin process, but in a basic lined furnace, is worked off in twelve hours. The roof of the furnace is of silica brick, as usual, but the junction between the roof and the sides of the hearth is made by a course of bauxite brick.

789. Pig-irons containing but little carbon or silicon are preferable for the open-hearth processes, since such irons require less time for decarburisation and fining, whilst also siliceous pig often yields an inferior steel, although the silicon may be, and is, wholly oxidised in the furnace. *Manganese*, when present beyond 0·5 per cent., delays the process, and also

tends to destroy the siliceous bottom of the furnace owing to the formation of fusible slags of manganous silicate. But, notwithstanding the above remarks, a mixture of several brands of iron is always preferable for ensuring uniform results, and chemical analysis alone is not sufficient to determine the quality and adaptability of a pig-iron for conversion into steel by this process, since frequently chemically similar irons will act quite differently in the furnace as to prolonging the process, destroying the bottom, and yielding a metal of deficient strength.

790. The *iron-ores* employed in the ordinary direct Siemens open-hearth process for the decarburisation of the pig-iron should be, for reasons above stated, of the purest classes, and as free as possible from sulphur or basic sulphates ; the ores more generally used for addition to the bath of metal are the Elba, Sommorostra, Mockta, and Marabella hæmatites.

CHAPTER XXI.

THE BESSEMER OR PNEUMATIC PROCESS FOR THE PRODUCTION OF STEEL FROM PIG-IRON.

791. THE conversion of pig-iron into steel by the Bessemer process, of which the world's present annual production amounts to nearly 3,000,000 tons, essentially consists in blowing a large volume of atmospheric air through molten pig-iron. The blast is introduced from below, and the molten pig-iron is decarburised and fined by the oxidation and combustion of its carbon, silicon, and manganese, with the development thereby of sufficient heat to keep the bath of metal in a fluid state to the end of the process ; while the metal so decarburised is usually then recarburised to the desired degree by the addition of a certain proportion of the

white manganiferous pig-iron known as spiegeleisen, or by the addition of a special alloy richer in manganese, constituting the ferromanganese of commerce. The Bessemer process is not adapted to the production of malleable iron, but it yields a steel, or, as it is occasionally called, "ingot iron," at a cheap rate, of fair quality for structural purposes, and possessing in its several grades a great range of temper or hardness.

792. *Grey pig-iron* is solely used for the process, since as the decarburisation and conversion into steel are entirely effected by the action of the oxygen of the air forced through the metal, the greater fluidity of grey iron is manifestly advantageous, since the plasticity of molten white iron is liable to interfere with the free passage of the blast through the metal during the earliest stages; but nevertheless, as will be shown when treating of the basic process, white or mottled iron may be employed, but not so advantageously as grey.

793. In the Bessemer process the oxidation and refining of the metal proceed simultaneously throughout the entire mass of the charge, and it is thus unlike the puddling process where the fining proceeds largely at the surface of the metal, under the combined influence of the oxygen of the air and of the oxides of iron and manganese in the puddling furnace cinder. In the ordinary Bessemer process, as conducted in a converter lined with ganister, practically the whole of the sulphur and phosphorus in the pig-iron remains in the steel produced, and since the yield of steel is some 10 per cent. less than the amount of pig-iron introduced into the converter, the proportions of these elements (sulphur and phosphorus) may be absolutely a little greater in the steel than in the pig-iron from which it has been produced; but in the puddling process it has already been shown that from 75 to 80 per cent. of the elements sulphur, phosphorus, and copper are removed in the cinder produced in the furnace. Hence for the original Bessemer process only the purer pig-irons, such as the hæmatites of Cumberland and

elsewhere, which are practically free from the above deleterious elements, are available ; but by a modification of the process introduced by Messrs. Thomas and Gilchrist, and known as the "basic process," in which the Bessemer converter is lined with a highly basic dolomitic lining, the sulphur and phosphorus of the pig-iron are very largely eliminated from the charge, and so phosphoric pig-irons, such as those of Cleveland and the Continent, are made available for use in the specially lined Bessemer converter.

794. The Bessemer process thus comprises the original process as conducted in a *siliceous or acid-lined converter*, and now generally known as the "acid process," and the "basic process" as conducted in a *basic-lined converter* ; but it is with the former, or acid process as conducted in the siliceous or acid-lined converter, that the considerations in the present sections refer.

795. In the conduct of the Bessemer process a blast of atmospheric air is supplied to the Bessemer converter at a pressure of from 18 to 25 lbs. per square inch, according to the weight of the charge, and the consequent depth of metal through which the blast has to be forced by the blowing engines. The blast is admitted from a number of small jets or perforations in the twyers fixed in the bottom of the vessel, and ascends through the molten pig-iron contained in the converter. Its effect is to oxidise and burn out almost the whole of the carbon, silicon, and manganese of the pig-iron, their removal following the same order as occurs in the puddling furnace or in the refinery, and the rapid combustion so set up within the converter raises the temperature of the bath to a very high degree, the rise of temperature commencing almost from the first entrance of the blast and continuing to the conclusion of the blow.

796. The Bessemer process is conducted in a vessel or converter, which may be either *fixed*, in the manner adopted to a limited extent in Sweden and revived by a patentee in South Wales, or, as is much more general, it is capable of *rotation* in a vertical plane through an

angle of a little more than 180° , for which purpose it is supported upon a pair of trunnion arms, resting upon suitable standards. The movable converter affords greater facilities for discharging the metal from the vessel at the end of the blow, and also by simply turning down the vessel into an almost horizontal position the charge lies outside the range of the blast from the whole of the twyers, and may there remain for some time after the blast is shut off. With the fixed vessel a mechanical arrangement -of a stopper or plug actuated by steam or air is necessary to close each twyer, to prevent the metal from running into and stopping up the air passages when the blast is stopped at the end of the blow.

797. The *movable converter* generally adopted for the conduct of the ordinary Bessemer process gives, as just noted, greater facilities than the fixed vessel for emptying out the charge of metal and slag after the completion of the blow by pouring it from the mouth instead of tapping it out from the bottom, as is necessary with the fixed vessel. The usual form of the converter is that shown in Fig. 90; it consists of a shell of wrought-iron plates riveted together, of which the neck or throat, *a*, of the vessel is inclined at an angle of about 30° to the body, *b*. The neck is directed, when the vessel is in the vertical position, towards an open chimney or stack, *κ*, into which the gases, flame, sparks, and ejections of slag, &c., occurring during the blow, are directed, and the hood, *s*, forms a like protection against sparks during the period the vessel is passing from the horizontal to the vertical position. Around the centre of the body of the converter is a stout band or trunnion ring, upon which is a pair of trunnion arms, *A*, by which the vessel is suspended upon cast-iron standards, or other supports. These converters, or vessels, have usually a capacity sufficient for the treatment of 6, 8, 10, or 15 tons of pig-iron at a single charge, and must not only be large enough to conveniently hold these amounts of fluid metal, but must also afford sufficient space to prevent the

ejection of the metal during the most active period of the boil. An 8-ton converter will accordingly measure

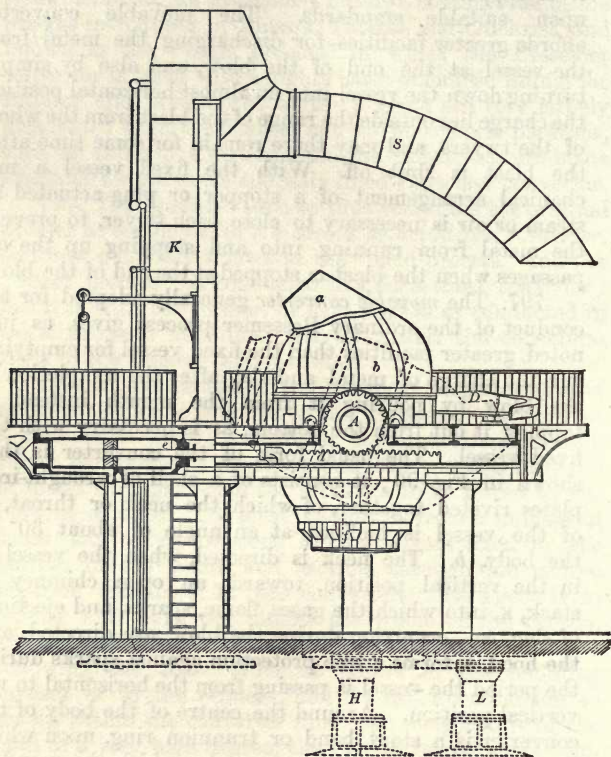

Fig. 90.—Arrangement of the Bessemer Converter.

at the trunnions about 8 feet 4 inches inside the casing, or 6 feet 10 inches inside the lining, the latter having a thickness of about 9 inches; whilst the shell plates are made $\frac{3}{4}$, $\frac{7}{8}$, and 1 inch in thickness, according to the

capacity of the vessel. The neck, *a*, of the converter forms a kind of spout during the teeming of the metal into the ladle, and its position also tends to prevent the ejections of metal, &c., during the blow. The size of the neck also requires consideration, since if it be too wide there is a loss of heat, and a tendency to deposit metal (skulls) around the mouth and inside of the vessel during the blow, and if the opening be unduly small, then the back pressure within the vessel is increased and the duration of the blow is prolonged.

798. Of the two trunnions, *A*, one is solid and carries a pinion, *c*, into which gears a rack, *d*, forming a prolongation of the ram or piston, *e*, of an hydraulic cylinder, which may be placed vertically in the masonry below, or horizontally, as shown. By the movement of the ram, *e*, the converter can be rotated through about $\frac{7}{8}$ ths of a revolution, by which the vessel can be moved into any position between the extreme vertical, when the mouth is directed towards the chimney, *K*, and the corresponding opposite position, where the mouth is directly downwards as required for the discharge of the slag, &c., from the vessel. The rack and hydraulic piston are thus required to be double-acting, so as to tip the vessel either upwards or downwards, and its action is controlled by a valve worked by hand, and placed at some distance from the vessel. The dotted lines in Fig. 90 show the vessel rotated into the horizontal position for receiving its charge of molten pig-iron, or of spiegeleisen, from the trough, *D*. The trunnion, *c* (Fig. 91), on the opposite side of the converter, is hollow, to permit of the passage through it of the blast from the blowing engines. From the hollow trunnion a pipe, *d*, of elliptical section passes to the cylindrical chamber, or *twyer box*, *f*, forming the movable bottom of the converter, but retained in position by means of bolts and cotters. The bottom, or *guard plate*, *g*, forming the upper side of the *twyer box*, *f*, is perforated by ten or fifteen (according to size of the vessel) circular holes pitched at equal distances

from one another, and into each of these holes is inserted a slightly conical fire-clay twyer, *k*, of about 20 or 22 inches in length, and perforated in the direction of its length by ten or twelve holes of $\frac{3}{8}$ inch in diameter for the admission of blast from the twyer chamber, *f*, to the body of the vessel. The lower ends of the twyers stand slightly below the lower surface of the guard-plate, but each twyer is held up in contact with the plate by stops carried in horizontal arms, which can be turned aside as required for the removal and renewal of any twyer, and for which purpose also the bottom plate, *t*, of the twyer box can be quickly removed. Thus, after knocking out and removing any faulty twyer, a new one is readily inserted by first luting it around with fire-clay, then driving it into the opening in the guard-plate, and finally securing it in position as before with the stops, and subsequently running in *slurry*—that is, a semi-fluid mixture of ganister and fire-clay with water—around the inside of the twyer so as to make a good joint; and after replacing the bottom plate, *t*, the bottom is dried, and the vessel is again ready for the reception of its charge.

799. Various arrangements in connection with the hollow trunnion have been devised for automatically turning on the blast as the converter is moved from the horizontal to the vertical position, so that during this movement the metal should not pass into and close the passages in the twyers; and also to shut off the blast, as soon as the metal in the converter is below the level of the twyers, in turning over from the vertical into the position for teeming at the conclusion of the blow; but it has been found in practice that these arrangements are liable to derangement, and generally the blast is now shut off and opened by a separate valve, under the control of the same man (vessel-man) who works the mechanism for turning over the converter as required at the commencement and conclusion of the blow.

800. The provision for the removal and renewal of single twyers in the converter bottom from time to time

has been already noticed; but a further improvement has been introduced and is now generally adopted, of constructing the bottom of the converter so that not only single twyers, but the entire bottom, can be removed and replaced in about three-quarters of an hour by a new bottom, thus obviating the loss of time from stoppages for the cooling, repair, and heating up again of the bottom, as required with the old or fixed bottoms, after every ten or twelve blows. Without some such means as the present for the removal and replacing rapidly of the old bottom, it would be impossible to obtain the sixty and seventy casts (requiring six new sets of twyers) during the day of twenty-four hours, as has been accomplished in America from a single pair of converters. This arrangement, known as the "Holley movable bottom," further obviates the necessity of running-in slurry or fluid ganister, &c., around the joints, with its defect of rendering it possible that a weak spot shall remain around the twyer through which the metal may break out. The Holley bottom (Fig. 91) is previously built up, dried, and then attached to the converter with the assistance of a hydraulic lift (H , Fig. 90), or other equivalent appliance; and the annular irregular space (a , Fig. 91) forming the junction of the bottom with the body of the vessel is inclined roughly at an angle of 45° , and is then directly accessible from the outside of the vessel, so that it can be closed perfectly by ramming in plastic cakes of ganister as required, whilst the interior of the vessel still remains red-hot. An old bottom is thus removed and a new one inserted with less than an hour's delay.

801. The *converter is lined* to a thickness of from 9 to 12 inches with a most refractory lining, b (Fig. 91), the material generally employed being a siliceous sandstone or *ganister* containing from 85 to 90 per cent. of silica, and which occurs below the Coal Measures. The ganister is first coarsely ground, and then is used either alone or in admixture with a little powdered fire-brick;

these materials are then mixed with a little water and rammed well in between the iron casing of the converter and a wooden model or core having the internal form of the vessel; or, instead of the whole lining being thus made up of ganister, the vessel is frequently first lined with a single thickness of fire-brick, with a proportionate decrease in the thickness of the ganister. For the

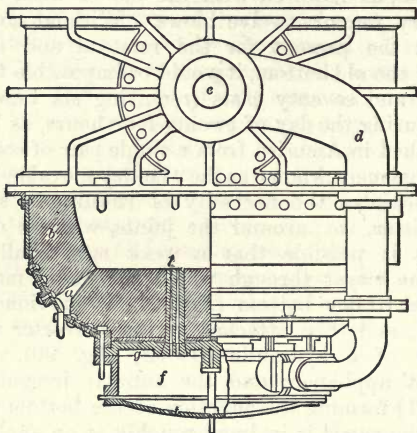

Fig. 91.—Lower Portion of Bessemer Converter showing Holley's Movable Bottom.

purpose of lining the vessel, the bottom is removed and the converter is then turned with its mouth downwards, when the mouth of the converter having been closed with a board, and the core or model introduced, the workman stands upon the top of the core and rams down the ganister with iron rammers around the sides of the core, between it and the external walls of the vessel. The ramming being completed, the pattern is withdrawn and the vessel rotated through an angle of 180° , when the bottom is refixed, and the whole is then carefully dried and heated up for the reception of the charge. Instead

of mixing the ganister with water in the preparation of the bottoms of the converter, in South Wales tar has been substituted for the water, and this yields, when heated, a non-volatile or fixed infusible cement of solid carbon, which is said to become exceedingly hard on drying, and to resist both chemical action and mechanical abrasion.

802. A *single Bessemer plant* usually consists of a pair of vessels or converters, generally arranged on opposite sides of a central circular casting-pit; although more recent practice is to place the vessels on the same side of the pit, arranged with their axes parallel to one another or inclined at a slight angle towards the centre; the latter arrangement gives greater space in the casting-pit, whereby a large number of moulds can be fixed at once, and the facilities for an increased output are thus thereby improved. In the centre of the casting-pit is fixed a hydraulic crane consisting of a central cylinder by which it is raised and lowered, and around which it revolves by gearing placed under the command of the workman, who stands on the crane; to the head of the central hydraulic ram is attached a pair of wrought-iron girders forming a platform, which carries the *ladle*, a balance for which is provided by a cast-iron counterpoise fixed at the other extremity of the table. The crane, after the ladle has received the charge of molten steel from the converter, is rotated in a horizontal plane over the tops of the moulds around the periphery of the pit, and the tap-hole of the ladle is thus brought successively over the centre of each mould, into which the metal from the ladle is tapped.

803. The gearing for turning over the converter, as also that for rotating and elevating the pit crane, is connected with valves and levers controlled by a man upon an elevated platform outside the casting-pit; but the gearing for moving the ladle in or out from the centre over the several moulds, is worked by a man on the platform of the crane, the same man also controlling the mechanism by which the ladle is finally turned over at

the close of the casting operation, to discharge the whole of the cinder, slag, &c., from the ladle into the slag-pit. With the arrangement in which the converters are placed side by side instead of opposite to each other, the central crane is made to serve the converters only, whilst two auxiliary but similar hydraulic cranes are fixed at opposite corners of the casting-pit, and there receive the ladle with its charge from the central crane and move it over the moulds for completing the casting operations, and the same cranes subsequently strip the moulds from the ingots, and remove the latter from the pits.

804. Between each pair of converters, but elevated considerably above the floor level, is built a small cupola for melting the spiegel or other manganiferous alloy to be added to the converter at the termination of the blow. This cupola stands so that a movable spout or shoot, D (Fig. 90), of wrought-iron lined with a mixture of ganister and fire-clay, will deliver the necessary spiegeleisen direct from the tap-hole of the cupola to the mouth of the converter, as the latter stands in the horizontal position for receiving the end of the spout; or at other works the spiegeleisen is first run into a ladle suspended upon a suitable weighing machine, and the required weight carefully run into the ladle before it is teemed from the latter into the converter. Also beyond the casting-pit, and at a short distance from the converters, are built the cupolas or other furnaces employed in melting the pig-iron to be run from them along a trough, like that last described, to the mouth of the converters. Formerly, when five or six blows per day only were made, two such cupolas sufficed for a pair of 8-ton converters, but more recently four large cupolas of 7 feet inside diameter, and 37 feet in height, have been erected to melt the pig-iron for a like pair of converters; while in America, where the most rapid working is made, the furnaces for melting the charge are even more numerous.

805. In England at the Barrow, the West Cumberland

and other works, and in America at Chicago and elsewhere, to save the time and expense of remelting the pig-iron, the molten metal is taken *direct from the blast furnaces* to be charged into the converters. For this purpose, at the Barrow works, the metal is tapped from the blast furnace as usual, but instead of running it into pigs it is run across the pig-bed in a sand channel to the boundary wall of the pig-bed, over which it falls from a spout into a ladle mounted on a carriage and wheels, standing for its reception in a sunken siding. When the ladle has received sufficient metal for a charge, the stream is stopped or diverted on to the pig-bed, whilst the surface of the molten metal in the ladle is covered with coal-dust, after which the ladle and contents are taken to an elevated siding, whence the metal can be discharged directly into the mouth of the converter. For ensuring greater uniformity in the composition of the charges, the metal for each charge is taken from several blast furnaces; and at Barrow the fluid pig-iron is conveyed upwards of a mile from the blast furnace to the converters; but at other works more complete and elaborate arrangements have been made for taking the metal direct from the blast furnaces. In Belgium, the metal for supplying a pair of 6-ton converters is taken direct from four furnaces from which the pig-iron is first run into ladles, which are then raised by an hydraulic lift as shown at L (Fig. 90), to the mouth of the converters where their contents are emptied into the vessels; but in order to keep up the continuous supply of molten pig necessary to get thirty casts per shift of twelve hours from the one pair of converters, two cupolas are also built in connection with the plant, and these supply 60 or 70 tons of metal per shift, which is run into the ladles as before, and elevated to the converter mouth in like manner.

806. The fixed Bessemer vessel, or converter, of a casing of wrought-iron plates riveted together and provided with a spout at one side for receiving the

molten metal of the charge, while the vessel is surmounted by a hood or dome for the escape of the gases. The casing is lined with fire-brick, whilst arranged in a circle around the bottom of the apparatus is a series of perforated clay twyers, and at the bottom of the vessel also is a tap-hole for drawing off the charge at the end of the blow. The tap-hole is closed during the blow by a suitable stopper, with a similar arrangement to that named above (§ 796) for closing the twyers.

807. The ladle (Fig. 92) employed for receiving the steel from the converters, and conveying it to the moulds, is constructed of iron plates riveted together like an ordinary foundry ladle, except that instead of the metal being poured from a lip in the side of the ladle, the lining of the Bessemer ladle slopes from all parts of the bottom towards the one point where the *tap-hole*, *a*, is situate. The tap-hole is closed

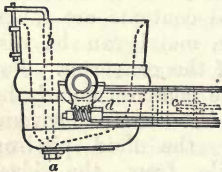

Fig. 92.—Elevation of the Bessemer Steel-Casting Ladle.

or opened by a fire-clay stopper or nozzle, attached to the end of an iron rod, *b*, coated with

clay, and which bends over and downwards over the top edge of the ladle in the manner shown, so that by connecting this rod or *goose-neck* with a suitable lever, the stopper can be raised or depressed for letting out or stopping the flow of metal from the ladle into the several moulds, over which the ladle is placed in succession, and into which the charge is to be cast. Care is taken during the casting that the metal does not wash the sides of the mould in its descent to the bottom, or otherwise unsound and sticking ingots frequently result. The ladle is suspended as already described, upon the two girders, *c*, connected to the head of the hydraulic pit-crane, and is provided with a worm and worm-wheel arrangement, *d*, for tipping the ladle over and emptying out the slag after the whole of the metal has been run into the moulds.

808. The ladle is lined with a refractory material such as sand or ganister, having the same or a similar composition to that of the lining of the converters. Where the metal is taken direct from the blast furnace, and very rapid working is aimed at, as many as fourteen ladles are sometimes prepared for a single Bessemer casting-pit, so that there may be always one or more ladles dry and in readiness, although for ordinary working four or six ladles will suffice for one pit. The ladles and stoppers are carefully dried and heated before running the steel from the converter into them.

809. The moulds in which Bessemer steel ingots are cast are usually of cast-iron, open at both ends, and are frequently octagonal or circular but more generally square in transverse section; and the moulds are made with a considerable taper from top to bottom, so as to allow of their readily *stripping* from the ingots shortly after casting the metal within them. While the more usual practice is to fill each mould separately, and to run in the steel from the top, yet casting in groups is also frequently pursued; for this purpose several moulds are arranged around a central one somewhat taller than the others, and into which the metal is run at the top, whilst by an arrangement of fire-clay tubes or passages leading from the bottom of the central or feeding ingot, and opening upwards into each of the other moulds of the group, all the moulds of the groups except the central ones are filled from the bottom, the steel gradually rising upwards to the required level. In every case the ingots are properly *stoppered down*, by throwing a shovelful of sand into the mould on the top of the still fluid metal, and then covering it with an iron plate fastened down by a cross-bar passing over the top of the plate and wedged down by wedges passing through eyes fixed for the purpose in the top of each mould. Ingots for rails are about $11\frac{1}{4}$ inches square, and are, when the group system is adopted, for the most part cast in groups of sixteen at once, for which purpose the bottom on which the moulds

are placed consists of a cast-iron slab or plate having the curve of the pit, and is about 13 feet long by 3 feet wide, with a recess in the middle of about 6 inches square and 3 inches deep for the reception of a brick, over which the central mould is fixed, the other moulds being arranged in a double row of four moulds each on either side of the central one, whilst channels or runners of fire-brick are made in either side of this central mould with sixteen branches opening upwards each into its own mould, and whereby the sixteen moulds are all cast at the same time, and each is run from the bottom.

810. For the conduct of the Bessemer process the converter or vessel, if not already strongly heated from the blowing of a previous charge, is dried and heated by first making within the vessel a fire of wood, to which coke is then added and a gentle blast turned on. This is continued until the lining has become thoroughly dry and has attained to a red heat, upon which the vessel is turned with its mouth downwards for the emptying out of the coke, the same being completely expelled from the converter by passing a strong current of blast through the vessel for a few seconds. The heated converter is then placed in the horizontal position (as shown in Fig. 90) for the reception of its charge of from 5 to 15 tons (according to the size of the converter) of molten pig-iron, which is delivered along a suitable clay-lined movable wrought-iron channel or trough D, into the mouth of the converter. The molten pig-iron is either delivered from the cupola in which it has been re-melted, or the charge is received direct from the blast furnace in the manner already described. The form of the converter when it stands in the horizontal position, permits of the charge lying in the hollow of the side of the vessel without reaching to the level of the twyers, and in addition to the pig-iron it is also not unusual to throw into the converter 10 or 12 per cent. of the charge in the form of scrap, consisting of rail ends, shearings, and various steel croppings, which

are added before the introduction of the molten pig-iron.

The vessel, thus charged, is turned up into the vertical position, after first turning on the blast to prevent the metal from passing into the twyers, since, if this is permitted to occur, it would partially or completely close the twyers, and so obstruct the passage of the blast.

811. During the passage of the vessel from the horizontal to the vertical position showers of sparks and burning graphite are ejected from the mouth of the converter, and for the first three or five minutes of the blow the flame from the mouth of the converter has a faint yellowish-red colour, is small in volume, very slightly luminous, and is accompanied by sparks, and these phenomena continue during the first stage of the blow which corresponds to the first step in the puddling process and during which the graphitic carbon passes into the dissolved or combined form, while the silicon also is being oxidised to form silica, which combines with ferrous and manganous oxides yielding slags of the silicates of iron and manganese. The temperature of the molten charge at the same time rapidly rises throughout this period, while the flame, which was more or less unsteady during the first stage, gradually increases in volume and luminosity, until in the second stage or "boil," lasting from six to ten minutes, it acquires a dense yellow colour, is very brilliant, and of very greatly increased volume, whilst frequently repeated ejections of slag and sparks of burning iron are also thrown from the mouth of the converter. During this stage the metal is in a state of violent ebullition, and carbonic oxide is being evolved in large quantities from the oxidation of the carbon in the pig-iron by the oxygen of the blast, whilst the pressure of the blast, which at the commencement of the blow was from 20 to 25 lbs. per square inch, falls during the boil to from 15 to 20 lbs. per square inch.

The boil is succeeded by the third or "fining" stage, which is characterised by the diminished volume, greater

transparency, less brilliancy, and pale rosy or amethyst tint of the flame, with fewer and less violent ejections of sparks, &c., from the converter mouth. In from eighteen minutes to twenty minutes from the commencement of the blow with an 8-ton charge, the "flame drops," or suddenly shortens, indicating the almost total decarburisation of the charge and the conclusion of the blow, upon which appearance the converter is rapidly turned down into the horizontal position and the blast shut off, any further continuation of the blow beyond this point being attended with oxidation, waste of iron, and deterioration of the product. From 7 to 10 per cent. of molten spiegeleisen, or a smaller proportion of ferromanganese, according to the temper of steel to be produced, is then run into the converter either from the ladle in which the alloy has been weighed, or direct from the small cupola already named, and in the same manner as the original charge of pig-iron was introduced. The introduction of the spiegeleisen is always attended by a violent reaction within the converter and the emission from the mouth of a long luminous and roaring jet of flame, the appearance of which indicates that the blow was fully completed before the converter was turned over; since, if the metal be much under-blown, the flame on the addition of the spiegeleisen does not appear, or is very small and feeble, owing to the small reaction induced by the spiegeleisen under this condition.

812. Formerly it was the practice to turn up the converter, and continue the blow for a few seconds after the addition of the spiegeleisen, but latterly this course has been discontinued, and the metal, after standing for a few minutes in the converter for the completion of all reaction following the addition of the spiegel or ferromanganese, and also to allow of the escape of gas and the separation of slag from the metal, is then poured from the mouth of the vessel into the ladle, sufficient slag being at the same time poured into the ladle to cover the surface of the fluid steel and retain the heat therein. The lining of the ladle is also heated to redness by burning

a coal or coke fire within the ladle, previous to the pouring of the steel into it. When the whole of the metal has been discharged from the converter, the ladle, which has in the meantime been standing on the central lift or crane of the casting-pit, is turned round from beneath the converter, and carried over the several moulds, when casting of the metal into ingots proceeds as already described. After the withdrawal of the ladle from beneath the mouth of the converter, the latter is turned right down, and the residue of the slag, with any detached ganister from the lining, &c., of the inside of the vessel, is discharged into the slag-pit beneath the converter, its more complete expulsion being effected by blowing a strong blast of air through the vessel for a few seconds.

813. The ordinary **Bessemer blow** in the ganister or acid-lined converter thus occupies from fifteen to twenty minutes for the conversion of 8-ton charges of English hæmatite; but with Swedish pig-iron the proportion of impurities, especially the silicon, is lower, and the conversion is accordingly much quicker, although it requires greater care and experience in its conduct to prevent overblowing, that is, blowing after the point of total decarburisation has been attained, for if this occurs then considerable loss and difficulty arise from the coating of the vessel and ladle with a firmly adhering coating or "skull" of metal. Swedish hæmatites, besides being lower in silicon are also richer in manganese than the English, and in the treatment of Swedish pig in the Bessemer converter, the boil commences earlier than with the English irons, and a larger amount of the brown vapours or smoke ascends from the mouth of the vessel during the earlier stages of the blow than occurs in the corresponding period of a blow in which English hæmatites are under operation.

814. The method, as described above, for the conduct of the Bessemer process thus consists in continuing the blow or current of blast, until almost complete decarburisation of the metal within the converter is attained, and

then restoring the necessary amount of carbon required for the conversion of the charge into steel of the desired hardness or temper by the addition of spiegeleisen, or other highly manganiferous alloy. It has also been proposed to attain the desired degree of carburisation in the finished product by arresting the blow at the proper point before total decarburisation is reached ; but this method, which was formerly used in Sweden, is not pursued in England, and the first-named method is generally adopted as affording less practical difficulty in its conduct, while also yielding more certain and uniform results. In Austria and Sweden also a "slag test," as described (p. 485), is adopted for the determination of the end of the blow, instead of watching for the dropping of the flame as last described.

815. The result of the reactions in the Bessemer converter is essentially the same as that occurring in the puddling or in the refining process, except as regards sulphur, phosphorus, and copper, which in the siliceous or acid-lined converter are not eliminated or diminished. In the Bessemer process the silicon of the pig-iron first suffers combustion and oxidation under the influence of the oxygen of the blast, with the formation of silica which immediately unites with ferrous and manganous oxides, yielding a siliceous slag which floats above the molten metal ; and, as shown in the following analyses (published respectively by the authorities of the Neuberg Works in Styria, and by Mr. Snelus when at the Dowlais Works) of the pig-iron employed, and of the condition of the charge at different periods of the process, it appears that the manganese is also oxidised rapidly, and that the iron does not oxidise to any appreciable extent until the silicon, manganese, and carbon have been almost entirely removed. If the blast be continued after the carbon has been eliminated, then the iron suffers oxidation and waste, and the *overblown metal* so produced, if examined, is found to possess the usual qualities of rottenness, &c., characteristic of burnt iron. As will subsequently appear when

ANALYSES OF PIG-IRON, AND OF THE BESSEMER CHARGE AT DIFFERENT PERIODS OF THE BLOW IN THE NEUBERG WORKS.

	Grey pig-iron smelted with charcoal from spathic iron-ores.	Metal at the end of the first stage of the blow.	Metal towards the end of the boil.	Metal before the addition of spiegel-eisen.	Final product of mild steel.
Graphite .	3·180	—	—	—	—
Combined carbon }	0·750	2·465	0·949	0·087	0·234
Silicon .	1·960	0·443	0·112	0·028	0·033
Phosphorus .	0·040	0·040	0·045	0·045	0·044
Sulphur .	0·018	trace	trace	trace	trace
Manganese .	3·460	1·645	0·429	0·113	0·139
Copper .	0·080	0·091	0·095	0·120	0·105
Iron . . .	90·501	95·316	98·370	99·607	99·445
	99·989	100·000	100·000	100·000	100·000

ANALYSES OF THE PIG-IRON AND OF THE BESSEMER CHARGE AT DIFFERENT STAGES OF THE BLOW, &C., AS PRODUCED IN THE DOWLAIS WORKS.*

	Melted pig-iron as charged into the converter.	Metal from the converter at the end of the first stage of the blow.	Metal after blowing for 9 minutes.	Metal at end of blow and before the addition of spiegel-eisen.	Steel from the cast ingot.	Steel from the rolled rail.
Graphitic carbon }	2·070	—	—	—	—	—
Combined carbon }	1·200	2·170	1·550	0·097	0·566	0·519
Silicon .	1·952	0·790	0·635	0·020	0·030	0·030
Sulphur .	0·014	trace	trace	trace	trace	trace
Phosphorus .	0·048	0·051	0·064	0·067	0·055	0·053
Manganese .	0·086	trace	trace	trace	0·309	0·309
Copper .	—	—	—	—	0·039	0·039

* Mr. Snelus, Iron and Steel Institute.

treating of the basic process, similar deterioration and waste of iron do not result from the short overblow in the treatment of phosphoric pig-iron in a basic-lined converter, since with the basic lining the combustion in the overblow is maintained largely at the expense of the phosphorus, while with the acid or ganister lining this oxidation of phosphorus is impossible.

816. The intense heat produced during the Bessemer blow is principally due to the high calorific power and extreme rapidity with which the combustion and oxidation of the silicon of the pig-iron to the condition of silica are effected. Silicon generates, during its combustion to silica, 7,830 units of heat (centigrade). Manganese also probably acts a like part as a generator of heat, and may thus partially replace the silicon in the pig-iron required for the Bessemer process, while carbon, although developing considerable heat by its combustion* and oxidation, produces gaseous carbonic oxide as the result of its combustion in the Bessemer converter, and this gas absorbs a large proportion of the heat so generated, and is thus largely carried away from the mouth of the converter without being utilised. If the blow be continued beyond the point of total decarburisation, then the heat is afterwards largely maintained by the oxidation and waste of iron, and this waste always occurs more or less towards the end of the blow. A large excess of oxygen is also left in the metal at the close of the blow which seriously affects the malleability unless sufficient manganese in the form of spiegeleisen or of ferromanganese, is added, to combine with this excess of oxygen, and so pass it out into the slag ; and the special use of ferromanganese instead of spiegeleisen is to enable sufficient manganese to be thus introduced into the metal for the removal of the oxygen without at the same time adding so much carbon and silicon as to render the metal hard. The metal at the end of the blow, before any addition of spiegel-eisen or ferromanganese has been made, resembles burnt

* Greenwood : " Manual of Metallurgy," Part I.

iron in its behaviour. It is red-short, unweldable, unforgeable at a red heat, crumbles and falls into powder under the hammer, and is altogether rotten and wanting in cohesion, owing to the presence of surplus oxygen and silicon in the metal; but these elements are removed and the malleability, &c., of the metal restored as just noted, by the use of manganese alloys, while the temper or hardness of the resulting steel depends largely upon the amount of carbon introduced in the spiegeleisen or other manganiferous alloy employed.

817. *Silicon* is thus essential as a heat producer for the successful conduct of the ordinary Bessemer process, and should be present to the extent of about $2\frac{1}{2}$ per cent. in the pig-iron applied to Bessemer use, yet any considerable excess of this element is a source of trouble, since the silica (SiO_2) produced by its combustion combines with ferrous oxide, thus increasing the proportion of slag in the converter and loss of iron in the process. It may also become difficult to completely remove the whole of the silicon before the metal has reached the degree of decarburisation requiring the stoppage of the blow, for the analyses (p. 479) show that the carbon and silicon are being simultaneously eliminated during the Bessemer conversion, and it is possible therefore sufficient silicon may remain in the metal to induce hardness, brittleness, and an inferior quality of steel after the carbon has been wholly removed, and it is thus usual to consider that the proportion of silicon in the pig-iron for this process should not exceed that of the carbon. But, as just stated, a *deficiency of silicon* also results in a cold-blow and inferior metal, whilst practical difficulties arise at the same time from the formation of skulls in the ladle and converter. Thus, since hæmatite pig-iron by remelting in the cupola usually loses about 1 per cent. of its silicon, it follows that with pig-irons such as certain varieties of those occurring in the South of France, &c., which contain the minimum of silicon required for the Bessemer process, they cannot, accordingly, be worked with any success after

they have been remelted in the cupola, although they work well if conveyed direct from the blast furnace to the converter.

818. The pig-iron required for the original Bessemer process is therefore of a special character, and the demands of the trade have thus produced in the market a special quality of hæmatite grey pig known as No. 1, No. 2, and No. 3 *Bessemer pig-iron*, indicating that such metal is of a quality adapted to the requirements of the Bessemer and other steel-making processes. Bessemer pig-iron is smelted from Cumberland or other hæmatite iron ores, and it contains at least 2 per cent. of silicon with not more than 0·1 per cent. of phosphorus; or for special qualities, as for plates, &c., the phosphorus should not exceed ·04 per cent. Such pig-iron is also required to be grey, since the use of white iron is attended with a greater loss of iron, whilst also the combined carbon in white iron passes into carbonic oxide in the earlier stages of the blow, before the necessary heat of the metal has been attained and the combustion of the silicon effected. Bessemer pig-iron is also almost free from sulphur and copper, since but very small quantities of these elements exercise an injurious effect upon the finished steel, and their proportion is not reduced during the conduct of the Bessemer process. The average quality of Bessemer pig will contain from 3·5 to 5 per cent. of carbon with 2 per cent. of silicon, 1 per cent. of manganese with 0·04 per cent. of phosphorus, and 0·04 per cent. of sulphur. The presence of manganese within certain limits is also desirable, since it acts as a heat producer in the Bessemer converter and combines with the excess of oxygen blown into the vessel, while its oxide unites readily with the silica resulting from the oxidation of the silicon, producing thereby readily fusible slags or silicates, which are however highly corrosive in their action upon the siliceous lining of the converter; but the oxidation and waste of iron from the action of the blast, and the deterioration

in the quality of the steel owing to the presence of ferrous oxide or of an excess of oxygen in the metal, are exceedingly limited, so long as there remains any unoxidised manganese in the charge. The pig-iron smelted from spathic ores sometimes contains the required proportions of silicon and manganese, and is sufficiently free from sulphur and phosphorus to be available, as in Westphalia, for the Bessemer process; but such pig-iron usually contains more copper than is present in the hæmatite irons; and thus, whilst English Bessemer steel contains only the small proportion of copper introduced into it by the addition of spiegeleisen or of ferromanganese at the end of the blow, the continental Bessemer steels, such as those of Neuberg, &c., frequently contain also small proportions of copper derived from the use of pig-iron which has been smelted from spathic ores. The pig-iron employed in Westphalia is smelted from a mixture of hæmatite and spathic ores.

ANALYSES OF BESSEMER PIG-IRON.

	No. 2 Grey Bessemer (Author).	South Wales Hæmatite (Head).	No. 1 Grey Hæmatite (Author).
Carbon, Graphitic	2·579	2·560	3·045
„ Combined	1·175	0·075	0·704
Silicon	1·758	3·650	2·003
Sulphur	0·014	0·053	0·008
Phosphorus	0·038	0·038	0·037
Manganese	0·130	0·576	0·309
Copper	—	0·027	—

819. The slags produced in the Bessemer process differ much, both in composition and appearance, from the corresponding slags of the puddling process; for whilst the puddling-furnace slag or cinder is a well-fused basic ferrous silicate, the Bessemer slag as left in the converter after the pouring out of the fluid metal, and then turned out into the slag-pit beneath the vessel, is

decidedly siliceous or acid in its character, and consists of a heterogeneous, porphyritic-looking, siliceous mixture, consisting of a well-fused portion of slag proper, cementing together considerable quantities of apparently unfused quartzose or siliceous matters detached from the sides and bottom of the converter during the blow. The composition of the slag, taken as a whole, is accordingly exceedingly varied; but the analyses and appearance of the *fused* portion, taken at the several periods of the blow, afford some evidence of the progress and condition of the blow at the corresponding stages; so much so that in Austria and Sweden a *slag-test* has been proposed and used for the determination of the point of decarburisation at which the blow is to be stopped. Agreeably with previous conclusions, the tabulated analyses below indicate that during the first and second stages of the process and until near the end of the boil, the silicon and manganese are being rapidly oxidised and removed with the formation of fusible silicates, whilst the iron during the same period is but little affected; but in the short period of the fining stage between the end of the boil and the conclusion of the

ANALYSES OF SLAG FROM THE GANISTER BESSEMER CONVERTER.

	Slag taken at end of the first period of the blow (Snelus).	Slag taken at end of the boil (Snelus).	Slag taken at end of blow before the addition of spiegeleisen (Snelus).	Slag taken after the addition of spiegeleisen (Snelus).	Siliceous mixture as emptied from the converter at the end of the blow
Silica . . .	46.78	51.75	46.75	47.27	72.25
Alumina . .	4.65	2.98	2.80	3.45	2.43
Ferrous oxide	6.78	5.58	16.86	15.43	20.65
Manganous,,	37.00	37.90	32.23	31.89	2.95
Lime . . .	2.98	1.76	1.19	1.23	1.04
Magnesia . .	1.53	0.45	0.52	0.61	0.13
Alkalies . .	trace	trace	trace	trace	—
Sulphur . .	0.04	trace	trace	—	0.86
Phosphorus .	0.03	0.01	0.01	0.01	trace

blow the iron suffers combustion, so that the slag, examined just before the addition of the spiegeleisen, shows a large increase in the proportion of ferrous oxide.

820. The slag test, noted above as having been in use in Austria and Sweden, is made by introducing an iron rod into the slag in the converter, upon withdrawing which a specimen of the slag adheres to the rod, and presents different appearances according to the degree of decarburisation attained by the metal in the bath. The slag always presents a peculiar brownish tint so long as the metal retains any carbon, whilst it becomes totally black, with the lustre characteristic of the presence of ferrous oxide, immediately the whole of the carbon is removed from the metal in the converter, and the various intermediate percentages of carbon are indicated by corresponding tints of the slag; thus, 0·75 per cent. of carbon in the charge is indicated by a lemon-yellow coloured slag, which changes to orange as the carbon falls to 0·60 per cent., becoming light-brown with a content of 0·45 per cent. of carbon, while 0·30 per cent. of carbon is indicated by a dark-brown colour, and 0·15 per cent. by a bluish-black slag.

821. The gases escaping from the mouth of the Bessemer converter, as shown by the accompanying results obtained from a blow of eighteen minutes' duration, indicate that at the commencement of the blow when the temperature is low and the flame is only slightly luminous, the carbon of the metal is being burnt to carbonic anhydride (CO_2), with an entire absence of carbonic oxide (CO); but after an interval of only two minutes the proportion of carbonic anhydride has begun to decrease, and carbonic oxide then forms a sensible proportion of the escaping gases. The proportion of carbonic oxide to carbonic anhydride in the gases escaping from the mouth of the converter, continues to increase as the temperature within the converter rises. During the boil, or from ten to fourteen minutes from the commencement of the blow, when a

very high temperature prevails in the converter, and a large luminous flame issues from the mouth of the vessel, there is a most notable increase in the proportion of carbonic oxide, whilst towards the end of the blow the flame assumes a reddish-violet tinge from the combustion of carbonic oxide at the mouth of the converter, and there is then an almost entire absence of carbonic anhydride in the escaping gases, until, finally, when the blow is over, and the limit of decarburisation is attained, the flame of carbonic oxide is succeeded by a stream of white-hot gas consisting largely of nitrogen.

ANALYSES OF THE GASES FROM THE MOUTH OF THE BESSEMER CONVERTER.

	Time after commencement of blow.*						After addition of Spiegeleisen at Bochum Works.	
	Two minutes.	Four minutes.	Six minutes.	Ten minutes.	Twelve minutes.	Fourteen minutes.		
Carbonic anhydride	10·71	8·59	8·20	3·58	2·30	1·34	—	0·86
Carbonic oxide . . .	None.	3·95	4·52	19·59	29·30	31·11	82·6	78·55
Oxygen	0·92	—	—	—	—	—	—	1·32
Hydrogen	88·37	0·88	2·00	2·00	2·16	2·00	2·8	2·52
Nitrogen †		86·58	85·28	74·83	66·24	65·55	14·3	16·38

822. Carbonic oxide is more stable at very elevated temperatures when in contact with metallic iron, than is carbonic anhydride under like conditions,† and it is suggested that this may account for the fact that whilst carbonic anhydride is present in the earlier and cooler periods of the Bessemer blow, yet it is almost entirely replaced by carbonic oxide at the higher temperature attained during the boil and at the end of the blow.

823. The temperature of the flame and of the escaping gases from the Bessemer converter at any period of the blow falls below that required to melt a wire of platinum or of an alloy of platinum and iridium, when the

* Snelus. Iron and Steel Institute.

† Experiments of J. S. Bell, Esq.

same is held within the flame ; whilst a wire of gold is always melted during the boil or towards the end of the blow ;* hence, since the melting-point of gold is about $1,300^{\circ}$ C., and taking the melting-point of platinum as $2,000^{\circ}$ C., it follows that the temperature of the flames rises to a point exceeding $1,300^{\circ}$ C., but never attains to $2,000^{\circ}$ C.

824. The rapidity of conversion, small amount of labour and extraordinary output of a Bessemer plant, contrast strongly with the old puddling operations. The fining of an amount of pig-iron which would occupy in the puddling furnace with its small charges, from two and a half to three days for its completion, is effected in a single Bessemer blow, lasting only about twenty minutes ; whilst in America sixty or seventy of such charges, averaging 8 tons each, are regularly made from a single pair of converters during the twenty-four hours, and as much as 2,830 tons† of steel have been produced in one week from such a pair of vessels ; but, generally, in England the output although very great, falls considerably short of these figures. These largely increased outputs are attributable to a great increase in the number of cupolas employed in melting the pig-iron, or where the metal is taken direct from the blast furnace, to the saving of the time required for remelting the pig-iron, as by these means it is possible to always keep in blast one or other of the converters in each pair ; also, further, greater rapidity of work has resulted from the general introduction of the method of more quickly replacing the twyers, converter bottoms, and of repairing the lining of the vessels upon the method introduced by Mr. Holley (p. 468) ; and lastly, the output has been increased by the better facilities and greater space afforded for placing, filling, and removing the ingots and moulds by arranging the two converters on the same side of the casting-pit instead of upon opposite sides of it, and at the same time increasing the number of cranes

* Dr. W. M. Watts.

† Windsor Richards, Cleveland Institute of Engineers, 1880-1.

available for fixing the moulds and clearing away the ingots, &c., from the pit. The importance and saving of time to be effected by the adoption of a ready method of changing the bottoms of the converters is obvious, when it is considered that after every ten or twenty blows, and sometimes after even less than this, the converter bottom requires complete renewal, and before this occurs from twelve to twenty tuyers will have been replaced by new ones; so that whilst the actual Bessemer blow lasts only from fifteen to twenty minutes, according to the class of pig-iron under treatment, yet the repairs to the converters, clearing the casting-pits of ingots, &c., replacing of moulds, and other preliminary operations, occupy by far the largest proportion of the time of the workmen.

825. After every eighty or ninety blows the converter requires thoroughly relining, the vessel having in the meantime been frequently partially repaired by ramming on patches of ganister upon the more corroded parts of the lining. To obviate the considerable loss of time necessitated by a stoppage for the relining, drying, and warming-up of a converter, a method of construction has been proposed by Mr. Holley, but as yet only partially adopted, whereby the body of the converter is made loose from the trunnion ring, to which it is secured during the working by wrought-iron knees and cotters, so arranged as to permit of their ready removal. Thus whilst the vessel rests securely upon the trunnion ring during the conduct of the blow, &c., yet by turning the vessel mouth downwards it is readily disconnected from the trunnion ring by removing the above-named cotters, and the body of the vessel is then received upon a bogie carried by the table of an hydraulic lift, H (Fig. 90), fixed below, and by lowering which, the converter freed from the trunnion ring as above is lowered bodily from its position, and so removed. By a reverse order of the movements a fresh vessel can be inserted and secured in position, so that by keeping extra vessels ready lined and dried the delay from

this cause is considerably reduced. Instead of the hydraulic lift and removal from below, in the manner just described, at Eston, for the removal of the basic-lined converters to be subsequently described, a 60-ton overhead travelling crane is arranged so as to lift the converter upwards from the trunnion ring and carry it away to a suitable carriage, whilst a fresh converter is, in the same manner, introduced from above.

826. The blowing engines employed for delivering the blast to the converters at a pressure of from 20 to 25 lbs. per square inch are of various types, vertical and horizontal, compound, non-condensing or condensing; but the consideration of the details of such engines would be too long for the present volume, and it must suffice to say that in the more recent compound types the high and low-pressure cylinders, A and B respectively (Fig. 93), are made with steam cylinders of 36 inches and 60 inches in diameter respectively, with blowing cylinders, c, c, each of 48 inches in diameter, and having a

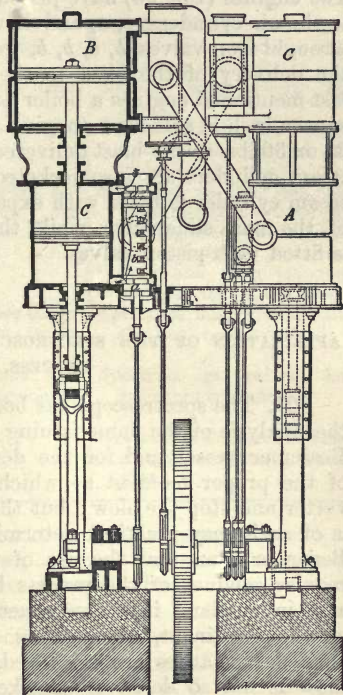

Fig. 93.—Elevation of Vertical Compound Bessemer Blowing Engines.

and having a

uniform stroke of 5 feet. Other engines have been made, however, a little larger in size, in which the high-pressure steam cylinder measures 42 inches in diameter, whilst the low-pressure cylinder is 78 inches in diameter, and the air or blowing cylinders for such engines are each of 54 inches diameter, all having, as before, a stroke of 5 feet. The engines (Fig. 93) have piston inlet valves, *a, a*, open to the air cylinders, *c, c*, and have several small circular wrought-iron valves, *b, b, b, b*, working automatically for the delivery of the blast to the blast main. With the last-mentioned engines a boiler pressure of 90 lbs. to the square inch is sufficient to give the required pressure of 25 or 30 lbs. to the blast delivered to the converters. The steam cylinders are also jacketed, and the high-pressure steam cylinder is fitted with expansion-slides on the back of the main slide-valve, while the low-pressure cylinder is fitted with piston valves.

APPLICATION OF THE SPECTROSCOPE TO THE BESSEMER PROCESS.

827. The spectroscope has been applied successfully to the analysis of the flame issuing from the mouth of the Bessemer vessel, and for the determination accordingly of the proper moment at which to turn down the converter and stop the blow; but the conclusion of the blow is of such easy practical determination to the practised Bessemer man that the use of the spectroscope in the regular conduct of the process has not been extensive, and in England it is now generally discarded, although on the Continent, where irons less siliceous than the English hæmatites are employed, the termination of the blow is not so decisively marked, and the instrument is still in occasional use. The principal phenomena observed at different periods of a blow lasting twenty-four minutes, as seen simultaneously by the naked eye and through the spectroscope, are herewith tabulated.

PHENOMENA OBSERVED BY APPLICATION OF SPECTROSCOPE TO
BESSEMER PROCESS.

Time from the commencement of the blow.	Appearances presented to the naked eye.	Appearance of the spectrum.
4 minutes	Very small flame with sparks of metal	Faint continuous spectrum.
5 "	Flame pale, but increasing in size	Continuous spectrum, with two yellow sodium lines flashing across it.
6 "	Large unsteady flame	Sodium lines steady and fixed.
8 "	Flame brighter and larger	Yellow sodium lines, with lines also in the red and violet bands, appear.
10 "	Boil commenced accompanied by bright dense flame	Spectrum as the last, but with additional lines appearing in the red, with carbon lines in the green and blue, and other manganese lines also in the green.
15 "	Flame becomes larger and more transparent	Spectrum more distinct, and the lines better defined.
20 "	Less luminous and diminishing volume of flame	Spectrum as before, but fading in intensity.
24 "	Flame drops	Green lines in the carbon and manganese bands disappear.

With less siliceous and more manganiferous irons, such as those of Sweden and the Continent, the spectrum is more obscured and less distinct from the larger proportion of brown fumes escaping from the mouth of the converter; with such pig-irons the boil also commences earlier than the above, and the yellow line of the spectrum flashes in about thirty seconds from the commencement of the blow, becoming steady and fixed in from one to one and a half minutes. The other appearances occur in regular sequence, as tabulated above, but the intervals between the several periods are less, and the blow terminates some minutes earlier.

THE BASIC PROCESS OF MESSRS. THOMAS AND GILCHRIST
FOR THE CONVERSION OF PHOSPHORIC PIG-IRON INTO
STEEL IN THE BESSEMER CONVERTER.

828. The pig-iron used in the ordinary Bessemer or acid process as last described, requires to be practically free from phosphorus, which renders pig-irons other than those smelted from hæmatite iron ores, unavailable for the production of steel in the Bessemer converter; but by the process introduced by Messrs. Thomas and Gilchrist, and known generally as the "dephosphorisation or basic process," the phosphoric pig-irons, smelted from the spathic and less pure ores of the Cleveland district of England, as also the similar brands of pig-iron rich in phosphorus smelted on the Continent, are rendered available for the production of steel in a modified Bessemer converter or in other steel-producing furnace. Hence the steel-producing processes, as conducted in the Bessemer converter or in the open-hearth furnace of Sir W. Siemens, are divisible into two classes; the one is conducted in acid-(siliceous) lined vessels or furnaces, in which only the purer kinds of pig-iron can be operated upon, and the second is conducted in similar vessels or furnaces, but with *basic* linings, which are capable of using the more impure phosphoric pig-irons. The first-named methods constitute the regular Bessemer and open-hearth processes described in the previous pages, and we shall now proceed to describe the processes for the conversion into steel of pig-iron containing considerable proportions of phosphorus, after the manner now regularly pursued at Eston and elsewhere in England, as also in Westphalia, Germany, Belgium, and France, where, from pig-iron containing on an average, as at Creusot,* 3 per cent. of carbon, 1·3 per cent. of silicon, from 1·5 to 2 per cent. of manganese, from 2·5 to 3 per cent. of *phosphorus*, and 0·2 per cent. of sulphur, steel is produced suitable for rails, yielding 0·43 per cent. of carbon, with a trace only of

* *Annales des Mines.*

silicon, 0·76 per cent. of manganese, 0·06 per cent. of phosphorus, and 0·02 per cent. of sulphur.

829. The basic process is conducted in a plant, arranged after the manner employed for the usual Bessemer process; but the application of *loose bottoms* and *interchangeable converters* named in the previous pages are of still greater importance in the conduct of this than in the ordinary process, owing to the much greater destruction of the lining of the vessel in the basic process, together with the difficulty of clearing the vessel of the hard and tough slag which accumulates within it at each blow, and which thus necessitates much more frequent stoppages for repair than occurs with the ordinary Bessemer process.

830. The *converters* employed in the basic process are generally shorter and wider than the ordinary acid-(ganister)-lined vessels, and the neck or throat, *g*, instead of being fixed at an inclination, is concentric (Fig. 94) with the body of the vessel, so that the metal can be received by and poured from the converter with equal facility upon either side of the axis of the trunnions whereby the duration of the lining is prolonged. The basic process is, however, frequently conducted in the

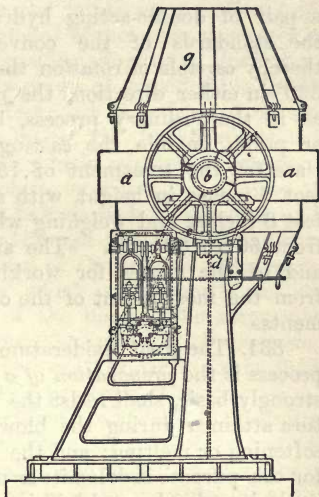

Fig. 94.—10-ton Converter employed in the Basic Bessemer Process.*

ordinary Bessemer converter and plant, with the substitution of a basic (dolomitic) lining for the ordinary

* *Proceedings of Inst. Civil Engineers*, 1881.

ganister lining. The 10-ton vessel (Fig. 94) constructed specially for the basic process is made in four parts, connected by bolts and cotters for ready detachment; the trunnion belt, *a*, and the arms, *b*, *b*, are of cast-iron, made in two pieces of box section, while the body is made of 1-inch wrought-iron plates riveted together and strengthened by strong straps. The trunnions are 15 inches in length and 21 inches in diameter, while the vessel itself measures 10 feet 8 inches across the trunnion belt. The tipping gear is attached to the trunnion arm as usual, and consists of a worm-wheel, *c*, 8 feet in diameter, gearing with a screw, *d*, of $4\frac{1}{2}$ -inch pitch, the latter receiving its motion in this case direct from the cranks of a pair of double-acting hydraulic engines, *e*, fixed on the standards of the converter, and the vessel is thereby capable of rotation through a complete circle, or 360° in either direction, the movement being controlled as in the ordinary process, by the man on the stage or pulpit outside the casting-pit. Converters of this class for the treatment of 15-ton charges measure 24 feet 5 inches in height, with an internal diameter of 10 feet 8 inches, and weighing when lined ready for work, from 60 to 80 tons. The arrangement of casting-pit, and of the cranes for working the pit, do not differ from the most recent of the ordinary Bessemer arrangements.

831. The great desideratum for the success of the basic process is the *preparation of a lining* which, whilst being strongly basic, shall resist the excessively high temperature attained during the blowing of the metal, without softening or melting; and the material generally applied for this purpose is dolomite or magnesian limestone, either made into bricks and laid in a cement of anhydrous tar, or the strongly burnt and ground dolomite is rammed into the vessel along with tar as the cementing material. But with a process whose introduction is so comparatively recent there are, as usual, numerous new proposals for the formation of the lining, but all at present appear to

employ a combination of hard-burnt magnesian limestone (dolomite) and anhydrous tar.

832. Dolomite on heating to whiteness contracts about 50 per cent. of its volume, so that it is necessary to heat the stone or the magnesian bricks, whichever are employed, to a high temperature before introducing them into the converter. The ground and hard-burnt stone, mixed with tar, is more generally employed in England, but in Westphalia and on the Continent the lining of the body of the converter is made of hard-burnt dolomite bricks, set in anhydrous tar asphalt, the bricks having been burnt at an intense white heat so as to be ringing hard, and thus not suffering disintegration by exposure; whilst the tar or cement used for the joints must not contain water or any appreciable amount of moisture, since steam has a very injurious disintegrating effect upon the lining. The bottom of the vessel is made of considerable thickness, measuring about two feet, and it is formed of the same materials as the body lining, viz., burnt or calcined dolomitic limestone and tar, which mixture is rammed well down upon a bottom plate, on which is a number of projecting spikes each about half an inch in diameter, and long enough to reach quite through the finished bottom. These pins, on the withdrawal of the bottom plate, leave holes through the bottom which subsequently act as twyers for the admission of the blast. The magnesite bricks employed contain about 93·85 per cent. of magnesia, with a trace of lime, 1·07 per cent. of ferric oxide, 0·58 per cent. of alumina, and 4·65 per cent. of silica.

833. With the converter illustrated (Fig. 94) the lining has been inserted somewhat differently; the upper portion or neck of the vessel is movable, and is relined separately, while the body itself may be lined in its place like the ordinary Bessemer converter, except that the core around which the basic lining is rammed is a cast-iron plug of the internal form of the vessel, and which has been heated by a coke fire previous to its insertion into the vessel. Into the space between this core and the old

lining a mixture of hard-burnt ground dolomite and tar is rammed, which becomes slightly plastic when heated, and so forms a solid compact mass around the core ; whilst the tar must have been previously boiled to expel all water. The bottom of the vessel is rammed up with a like mixture as last described. During the working of the process the lining of the body of the vessel is never allowed to wear below 3 or 4 inches in thickness before stopping for thorough repairs.

834. The converter having been suitably lined with basic material and carefully warmed up, the process of conversion is commenced by first introducing into the vessel well-burnt lime, as free as possible from silica, to the extent of from 15 to 20 per cent. of the weight of the charge of pig-iron, and a little coke breeze is at the same time added, and these materials are then brought to a bright glow by gentle blowing through the converter, before the charge of from 7 to 15 tons of molten phosphoric pig-iron, low in silicon, and at as high a temperature as possible, is introduced into the vessel. The blast at a pressure of about 25 lbs. per square inch, is now turned on, when the converter is turned up, and the blow lasting from thirteen to twenty-five minutes, is conducted in the usual manner until the carbon is eliminated from the charge ; but instead of stopping the blow at this point, according to the ordinary Bessemer practice, the blow is continued for two or three minutes longer, and it is during this *over- or after-blow* that the phosphorus is removed from the metal. The carbon lines in the spectrum of the flame usually disappear in about ten minutes, in a blow lasting altogether about fifteen. During the after-blow the temperature rises rapidly, attaining eventually to about 1,800° C. ; and during this period also red fumes are emitted from the mouth of the vessel, at first only slightly, but they become more copious and increase in density towards the end, and particularly during the last half-minute of the conduct of the process. The larger the

proportion of phosphorus in the pig-iron, the thicker is the smoke and greater the elevation in the temperature. When the process is judged to be nearly complete, and the phosphorus to be almost eliminated, the vessel is turned down, and a sample of the metal is removed in a suitable ladle and cast into a small ingot, which is then hammered out flat, cooled in water, and broken, when, according to the degree of its malleability and ductility, with the appearance of the fracture, the workman judges of the degree of purification, and the vessel is again turned up, and the blowing resumed for a short time longer if the dephosphorisation is thought to be incomplete. The operation of sampling is repeated until the desired condition is attained, but with practice usually one sampling will suffice to determine the end of the blow.

835. The *fracture of the sample* taken from the converter presents large and bright crystals when the process is incomplete, the crystals becoming smaller as the dephosphorisation is more perfect. When a satisfactory test-sample has been obtained, the slag is run out from the converter as completely as possible to prevent any portion of the phosphorus from being again reduced from the slag by prolonged contact with the molten metal; but at other works, again, as at the Hörde Works, the slag is not run off before the spiegel is added. The necessary amount of spiegeleisen, or of ferromanganese, or of both, is then added in the usual way, the molten spiegeleisen being added to the metal in the converter, whilst a little ferromanganese in its cold state is thrown into the ladle; but the addition of spiegeleisen is attended with only a weak and much less marked reaction than occurs at this stage of the acid process. The necessary recarburisation having been thus effected, the teeming of the metal into the ladle and the casting into ingots are conducted in the usual manner. Instead of adding the spiegeleisen or ferromanganese to the converter in the manner just described, in another modification of the basic process the metal at the end

of the after-blow is emptied into the ladle, and then a proportion of molten hæmatite pig-iron is added thereto, whereupon a violent reaction usually ensues and the slag overflows the ladle. After the reaction has subsided a small proportion of spiegeleisen or of ferromanganese is added to complete the recarburisation of the steel, and then the casting proceeds as before.

836. The following analyses indicate the *changes in the*

ANALYSES OF THE METAL AT VARIOUS PERIODS OF THE BASIC PROCESS AS CONDUCTED IN WESTPHALIA.

	Original pig-iron.	Metal after blowing for			
		4½ min.	9½ min.	11½ min. and end of ordinary blow.	13 min. or end of after-blow.
Carbon .	2.94	2.48	0.811	0.049	—
Silicon .	0.538	0.009	—	—	—
Phosphorus .	0.523	1.25	1.32	0.786	0.021
Manganese .	1.22	0.247	—	—	0.123
Copper .	0.611	0.111	—	—	0.119
Sulphur .	—	0.206	0.277	0.262	0.206

ANALYSES OF METAL AT VARIOUS PERIODS OF THE BASIC BESSEMER PROCESS AS CONDUCTED AT ESTON.*

	Original pig-iron.	Metal after blowing for					Steel after addition of spiegel.
		6 min.	12 min.	14½ min. or end of ordinary blow.	16½ min.	16 min. 35 sec. or at end of after-blow.	
Carbon .	3.57	3.40	0.88	0.07	trace	trace	0.124
Silicon .	1.70	0.28	0.01	trace	nil	nil	0.030
Phosphorus	1.57	1.63	1.42	1.22	0.14	0.08	0.22
Manganese.	0.71	0.56	0.27	0.12	0.10	trace	0.270
Sulphur .	0.06	0.06	0.05	0.05	0.05	0.05	0.04

* *Proceedings of Cleveland Institute of Engineers.*

composition of the charge in the *basic-lined* converter at various periods of the blow, as examined at Eston and in Westphalia, and from these it appears that the carbon, silicon, and manganese begin to burn off almost at the commencement of the blow, while the phosphorus remains practically unchanged up to the end of the ordinary blow; but during the two or three minutes of the *after-blow* the phosphorus is rapidly oxidised and eliminated from the metal, while the proportions of carbon and silicon during the same period do not suffer further change. At Hörde* the green carbon lines are observed in the spectrum of the blow two minutes after the commencement, while in about ten minutes the green lines disappear, indicating the termination of the ordinary blow according to the old or acid process, whilst an after-blow of about two minutes is necessary for the elimination of the phosphorus. The third series of analyses below show that after the addition of the spiegeleisen there is, besides an increase in the amount of carbon, also a sensible increase in the percentage of both silicon and manganese present in the steel; and it is to be further noted that after the addition of the spiegeleisen a slight increase occurs in the amount of phosphorus in the steel beyond

ANALYSES OF THE CHARGE IN THE BASIC-LINED CONVERTER
AT THE RHENISH STEEL WORKS.

	Original pig-iron from the cupola (Jordan).	After blowing 10 min. (Jordan).	After 2 min. over-blow or 15½ min. from the commencement (Jordan).	Steel after addition of spiegel (Jordan).
Carbon . . .	3.276	0.590	0.026	0.302
Silicon . . .	0.476	0.222	0.002	0.016
Phosphorus . . .	2.600	2.064	0.062	0.092
Manganese . . .	1.131	0.122	0.197	0.540
Sulphur . . .	0.062	0.139	0.051	0.040

* Dr. F. C. G. Müller : *Glaser's Annalen*, 1880.

what was contained in the spiegel itself, and that a small proportion of this element must have been therefore reduced at this stage in some manner from the phosphoric anhydride in the slags.

837. Phosphorus can thus be eliminated during the Bessemer blow in a basic-lined converter, but for success the *slag also should be as basic as possible*. The phosphoric anhydride produced in the converter as the result of the oxidation of the phosphorus, either directly by the oxidising action of the blast, or by the reaction of phosphorus upon ferrous oxide, with the production thereby of ferrous phosphate and metallic iron, could in either case only exist in the converter in combination with a powerful base; and any excess of silica present in the slag would therefore at once set free the phosphoric anhydride from any oxide of iron with which it had combined, and the phosphorus would then be again reduced by the carbon, or at the high temperature prevailing in the converter even by the iron itself. But it is more probable, owing to the excess of silica always present in the *ganister-lined* converter, that any ferrous oxide that may be formed during the process immediately enters into combination with silica, and thus any phosphoric anhydride resulting from the oxidation of phosphorus would not come into contact with any ferrous oxide with which to enter into combination, and without it the phosphoric anhydride would immediately be again reduced by the carbon present in the metal. But with the *basic-lined* vessel, on the contrary, the phosphoric anhydride resulting from the combustion of the phosphorus enters at once into combination with the lime added to the charge, and yields thereby a calcic phosphate which is not subsequently reduced, whilst it is probably owing to the superior affinity of carbon for oxygen over that of either phosphorus or iron for oxygen that the combustion and oxidation of the phosphorus and iron in the charge do not take place to any appreciable extent until the whole of the carbon is eliminated.

838. The slags produced in the basic process are small in quantity except towards the close of the blow, when they become more abundant, and finally exceed the amount in the ordinary Bessemer process. These slags are highly *basic* silicates of lime and magnesia, containing also, as would be expected, notable proportions of phosphoric anhydride and ferrous oxide, but the proportions of these last-named oxides are small during the earlier stages of the blow increasing, however, towards the end, and assuming large proportions in the slag produced during the last minute of the after-blow. Average specimens of the slag produced in the basic process contain about 10 per cent. of silica, with from 10 to 15 per cent. of phosphoric anhydride, about 10 per cent. of ferrous

ANALYSES OF THE SLAGS TAKEN AT THE END OF THE
BASIC PROCESS.

	Slag produced at Creusot.*	Slag at end of the after-blow.	Slag after the addition of spiegel-eisen.	Slag at the end of the ordinary blow.	Slag at period of total decarburisation but before the after-blow.	Slag at end of dephosphorisation or after-blow.
Silica	16.50	8.05	8.22	9.67	22.00	12.00
Alumina and a little chromic oxide)	3.80	—	—	Not determined	—	—
Lime	46.30	56.54	56.03	46.94	47.00	54.00
Magnesia	4.00	3.10	3.29	Not determined		
Ferrous oxide	7.07	8.37	9.24	10.20	11.00	11.00
Manganous oxide	5.30	4.45	6.27	Not determined		
Sulphur	—	.33	—	—	—	—
Sulphuric anhydride	0.63	—	0.29	—	—	—
Sulphates	—	—	—	—	5.00	5.00
Phosphoric "	13.74	18.55	17.15	9.70	12.00	16.00
Vanadic acid	1.92	—	—	—	—	—

* *Annales des Mines.*

ANALYSES OF THE SLAG OR CINDER AT VARIOUS STAGES OF
THE BASIC PROCESS.*

	Time from commencement of blow.				Slag from the ladle after teeming the metal.
	6 min.	12 min.	14½ min. or end of decarburisation.	16 min., or end of after-blow.	
Silica	42.60	35.60	33.00	16.60	18.60
Phosphoric anhydride	0.15	2.61	5.66	16.03	13.87
Metallic Fe	2.00	4.80	6.15	11.35	7.10

oxide, and from 40 to 50 per cent. of lime and magnesia, accompanied by variable quantities of manganoous oxide. It thus appears that these slags very materially and fundamentally differ from the ordinary Bessemer slags, which contain at least double the above proportions of silica, while frequently reaching a content of over 50 or 60 per cent of silica (see analyses on p. 484). The *quantity of pure slag* produced in the basic-lined converter is about 20 per cent. of the weight of the steel produced, and is thus almost double the amount yielded in the siliceous or acid-lined converter. The increase in the basicity of the slag during the after-blow is shown by the last series of tables above, as is also the notable increase in the phosphoric anhydride which rises from 5.66 per cent. at the point of total decarburisation of the charge to 16.03 per cent. at the end of the after-blow, while in like manner, the iron, which amounted to 6.15 per cent. at the first-mentioned period, stands at 11.35 per cent. at the end of the over-blow.

839. The pig-iron for the basic process, unlike that required for the ordinary Bessemer process, requires to be low in silicon and sulphur, but comparatively rich in *phosphorus*, average samples of such pig as is used in the basic

* *Proceedings of Cleveland Institute of Engineers.*

process containing from 0·5 to 1·0 per cent. of silicon, from 0·05 to 0·15 per cent. of sulphur, 0·35 to 2·00 per cent. of manganese, and from 1 to 3 per cent. of phosphorus, the higher proportions of phosphorus and manganese being, however, preferred. White pig-iron is generally employed, as affording less loss during its conversion, both as to direct waste of metal and in the wear of the basic lining of the vessel, while the length of blow with such metal is also of shorter duration; yet either white, grey, or mottled pig-irons are available for the process.

840. The fuel or heat-producing elements in the pig-iron of the ordinary Bessemer process (p. 480) are silicon, manganese, and carbon, whilst in the dephosphorisation or basic process, besides the elements just enumerated, *phosphorus* requires to be added to the list of heat-producing elements. Phosphorus affords by its combustion to phosphoric anhydride 5,747 heat units (C.), and performs the same calorific function during the "after-blow" in the basic process that silicon does during the ordinary Bessemer blow, hence, within certain limits, it may be considered that the value of a pig-iron for the basic process is directly proportional to the amount of phosphorus which it contains, so that even tap-cinder mixed with the manganiferous ores of Spain is being smelted in Cleveland for the production of a cheap phosphoric pig-iron, available for the basic process.

841. The presence of an *excess of silicon* in the pig-iron used for conversion into steel in the basic-lined vessel increases the amount of slag, and more rapidly destroys the lining of the vessel, besides which it increases the waste of metal, and prolongs the blow by lengthening the period necessary for the slag to attain the basicity required before the elimination of phosphorus can be effected. But if silicon be entirely absent, then the blow becomes too cold and slow; hence the metal for treatment by the basic process should contain a small proportion of silicon, as previously mentioned, but the process cannot deal with highly siliceous pig-iron.

842. Where the silicon in phosphoric pig-iron exceeds about 1 per cent. such pig-iron is best treated by the "transfer method," according to which the metal is first treated for its partial desilicisation in the ordinary Bessemer converter with an acid lining, from whence, after blowing for ten or fifteen minutes, the metal is transferred, with the exclusion of as much as possible of the siliceous slag, to a basic-lined converter, in which the blowing is resumed for about three minutes for the elimination of the phosphorus. The transfer method was pursued at Witkowitz with two converters, one acid and the other basic-lined, and the following analyses show the composition of the metal after treatment in the acid-lined vessel for partial decarburisation and desilicisation, and of the same metal after transference to the basic-lined vessel for dephosphorisation; but the method is now abandoned for the unmodified process with the basic-lined converter only.

ANALYSES OF PRODUCTS AT TWO STAGES OF BASIC PROCESS
BY TRANSFER METHOD.

	Molten pig-iron.	After treatment in acid-lined converter for partial decarburisation, &c.	After completion in basic-lined vessel.
Carbon	3.5 to 4	0.22	0.14
Silicon	2.5	0.81	traces
Phosphorus	0.17	0.20	0.036

843. *Manganese* is desirable in the pig-iron to the amount previously named (p. 503) for use in the basic process, since its presence favours the elimination of sulphur, which is otherwise reduced only in small degree by the process; and, also, in its absence the after-blow is liable to produce an inferior and uncertain temper of steel.

844. The yield in the basic process is about 85 per cent. of the weight of the charge of pig-iron, &c.,

introduced into the vessel, as against about 90 per cent. with the ordinary Bessemer process, while the output or number of blows obtained from the basic-lined converter is only about eight or ten per day of twelve hours for each vessel.

845. The wear upon the dolomitic or basic lining of the vessel is also heavier than upon the ganister or acid-lined vessel, so that, as previously noted (p. 493), the form of the ordinary converter has been modified, with a view to the equalisation of the wear upon its two opposite sides, by arranging for the vessel to receive the molten pig-iron and also to deliver the charge of steel into the ladle from either side of the converter indiscriminately; but notwithstanding this, the basic-lined vessel requires either relining or very considerable repairs after about every sixty blows. In Bohemia, where loose twyers are employed, the bottoms last on an average from twenty-five to thirty blows before needing renewal; but the twyers are replaced singly or in pairs during the interval, as required. In the Cleveland works, where no such renewals of the twyers are made, the bottoms only last about eleven blows before requiring to be replaced. Since the amount of steel produced from a basic-lined converter before relining becomes necessary, is considerably less than that produced from the siliceous-lined vessel, it follows that if the same make is to be obtained by the basic as with the acid process, then either more vessels will be required or greater facilities for rapidly changing the vessels must be adopted, and thus the application of the methods devised by Holley and others for rapidly removing one converter and replacing it by another are of more urgent importance in the basic than in the ordinary process.

846. The amount of basic materials, as lime, &c., added to the vessel per ton of steel produced, varies according to the proportion of silicon and phosphorus in the pig-iron under treatment, but ranges generally between 1 and 3 cwts. of lime per ton of steel produced.

847. The economy to be derived by taking the pig-iron *direct from the blast furnaces*, instead of remelting it in the cupola before charging it into the vessel, applies equally to the basic as to the ordinary Bessemer process, while, in addition to economy, the direct working has the further advantage of avoiding the contact of the pig-iron with the sulphur and other impurities of the coke.

848. Proposals and experiments for *avoiding the after-blow* required in the basic process have been made and conducted by the addition of fluor-spar or alkaline carbonates to the charge, but as yet the method by the "after-" or "over-blowing" of the charge is generally pursued at the works where the basic process is carried out.

CHAPTER XXII.

THE PRODUCTION OF HOMOGENEOUS STEEL INGOTS, FLUID COMPRESSION OF STEEL, COMPOUND ARMOUR PLATES, ETC.

849. In the ordinary methods of casting steel ingots by running the fluid steel into cold, or comparatively cold ingot moulds, much difficulty is experienced in producing thoroughly sound castings or ingots, especially if the latter be of large size or of the milder tempers; and the difficulty is also greater with Bessemer and open-hearth steel than with crucible metal.

850. The unsoundness of steel results from the existence either of a central funnel-shaped cavity or pipe at the top of the ingot, or of dispersed cavities throughout the casting. The former is due to the contraction of the interior of the mass after the outside has set, and is most generally observed in the harder tempers of steel, and can be mitigated by special care in pouring the metal and by special devices; but the latter and more troublesome form is that (Fig. 95) in which a large proportion, but especially the upper half of each ingot of mild steel,

is permeated by honeycombs or dispersed cavities, due to the liberation within the metal of the imprisoned gases, consisting, according to Parry, Müller, Stead, and others, principally of hydrogen (about 85 per cent.) and nitrogen (15 per cent.) (p. 392). These gases are absorbed, dissolved, or occluded in the molten steel, but are wholly or partially evolved, and collect into bubbles immediately the metal after running into the mould begins to cool and solidify, such bubbles of gas probably adhering after their liberation, to the first solid particles of metal with which they come into contact; and since the sides of the ingot cool first, and further cooling and solidification proceed from this inwards, hence usually the bubbles are found more numerous towards the sides of the ingot, and are also arranged in lines perpendicular to the sides of the ingot.

851. Steel ingots of the softer tempers usually boil up or rise, as already noted, during the period of casting, and they invariably present the above honey-combed structure, although ingots which have not boiled, and which present externally the appearances of solidity, may still be interspersed with cavities or holes throughout the mass.

852. Various devices have been proposed with more or less success for overcoming the unsoundness in ingots of mild steel, such as by dead-melting already referred to, by teeming the metal at a higher temperature, by the addition of silicon to the metal at the end of the steel-making process, by subjecting the fluid metal to high pressure during its solidification, by imparting a rotary motion to the moulds in which the metal is cast, &c.

853. The use of silicon, or of silico-ferromanganese, in which form the silicon is introduced into

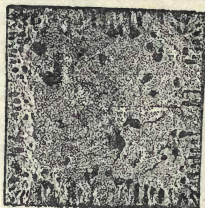

Fig. 95.—Cross Section towards the Top End of a Bessemer Steel Ingot showing Honeycombs.

the steel, for the production of sound castings dates back for a considerable period, but it is only since the exhibition in Paris in 1877 that general attention has been strongly directed to its practicability. At that date the Terre Noire Company exhibited a large collection of remarkably fine and sound castings made by the aid of a silico-ferromanganese, or, as it is sometimes called, a "*ferromanganese-silicon melting*," which is added to the molten metal in addition to, or instead of, the ordinary spiegeleisen or ferromanganese. Specimens of the silico-ferromanganese employed by the above company contain about 2·18 per cent. of combined carbon with 18·25 per cent. of manganese and 10·82 per cent. of silicon, and this substance is added to the steel from the Bessemer converter, or from the open-hearth furnace as it stands in the casting ladle. Sufficient of the alloy is added to yield a steel containing from 0·2 to 0·3 per cent., or with the harder qualities from 0·3 to 0·4 per cent. of silicon; whilst, to neutralise the pernicious effect of such a large percentage of silicon in the metal, M. Pourcel considers it necessary to introduce manganese into the steel in sufficient quantity to render the ratio of silicon to manganese as two is to three. Steel with such large contents of silicon, however, suffers in malleability, ductility, and in tensile strength, and it also requires much more care if it is treated under the hammer.

854. The silico-ferromanganese is first raised to a red heat and is added to the bath of metal immediately before running the metal into the moulds, when all ebullition previously going on in the metal is at once arrested, the surface of the metal becomes perfectly tranquil, and the gas ceases to rise through the slag. The phenomena attending the addition of silico-ferromanganese are thus quite different from those which occur when spiegeleisen is similarly added to the bath at the end of the Bessemer process, when the mixture is at once attended by a violent reaction and escape of gases from the mouth of the vessel. M. Pourcel, of the Terre Noire Company, considers that silicon prevents

ANALYSES OF TERRE NOIRE SILICON STEEL.

Carbon.	Manganese.	Silicon.	Sulphur.	Phosphorus	Copper.
0.39	0.83	0.29	0.05	0.10	0.06
0.807	0.672	0.163	trace	0.097	—
0.61	0.70	0.23	0.05	0.12	—
0.287	0.693	0.233	trace	0.076	—
0.65	1.00	0.25	—	—	—

the formation of blow-holes or unsoundness, owing to its greater oxidability over carbon, whilst the product of its oxidation (silica) is solid, and, by its combination with manganous oxide as a base, yields a slag which is fluid at the temperature of solidification of the steel,* and so liquates from the metal; but Müller, on the contrary, deduces that silicon acts by increasing the solvent action of the metal, so that the bath of steel, which might be saturated with gases before the addition of the silicon, becomes after the addition only partially so, and thus the separation of gases within the metal is prevented, with the production thereby of more solid and homogeneous ingots. Müller also suggests that one of the benefits derived from the use of spiegeleisen as the recarburising medium at the end of the Bessemer process is in part due to the sudden evolution of carbonic oxide attending its addition, and by the escape of which a proportion of hydrogen is also swept out from the metal and sounder ingots thereby produced.

855. Of the *methods employed for producing sound ingots by the application of pressure to the fluid metal*, the ordinary plan of stoppering the moulds with sand, as already described, produces a resistance to the rising of the fluid metal within the mould, whereby a certain portion of the gases are kept in solution, and prevented from forming bubbles during the process of solidification; but this method is very ineffective for the production of even approximately sound ingots of mild steel.

* *Stahl und Eisen*, vol. ii., p. 531.

856. Sir Joseph Whitworth and Co. produce *sound ingots* by submitting the metal while in its fluid state, to considerable pressure applied by means of powerful hydraulic machinery, under which the metal is allowed to solidify; but the pressures required for the production of perfectly sound ingots are very great, varying from

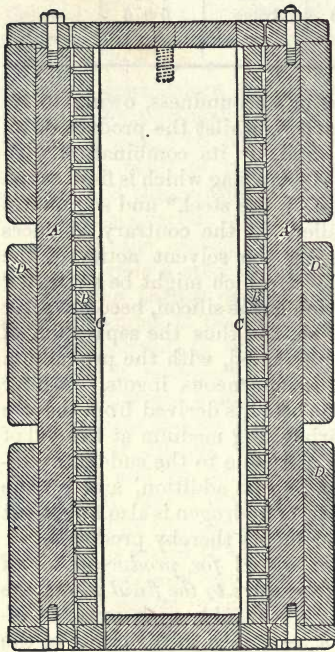

Fig. 96.—Vertical Section of the Mould employed in the Compression of Steel whilst in its Fluid State.

6 to 20 tons per square inch of the horizontal section of the ingot under treatment, according to the size of the ingot and the temper of the metal. Hence the moulds employed in the process are required to be of great strength and the presses of enormous power, one, erected by the writer in the Abouchoff Works, St. Petersburg, exerting a maximum aggregate pressure of 10,000 tons. The process is thus expensive, and is principally applicable to the production of the specially superior class of metal required for the manufacture of heavy marine shafts, ordnance, and the like.

857. The moulds employed in Sir Joseph Whitworth's process of fluid compression are of special construction, and consist (Figs. 96, 97) of an outer steel cylinder, A, supported by

steel hoops, D ; within the cylinder is an inner lining of cast-iron lagging, B, and inside this again is a lining of refractory material, C, the whole constructed, as shown, to allow of the ready escape of the gases, &c., which are expelled during the process of compression.

858. The construction of the hydraulic press employed by Sir J. Whitworth and Co. in the process of fluid compression is similar to the forging press described on p. 316, except that there is no cylinder carried in the movable head of the press, the pressing cylinder being in this case placed beneath the platform upon which the mould containing the fluid metal stands. The pressure is thus applied from below against a solid top plunger carried by the moving head.

859. The metal is tapped from the ladle into the previously well-dried and warmed mould, after which the latter is run by suitable hydraulic machinery between the moving head of the press and the lower pressing cylinder,

whereupon the movable head of the press carrying a ram fitting loosely into the top mould, descends upon the metal ; and when the weight of the head has been fully received by the fluid metal, the moving head of the press is then firmly locked in position by the nuts, in the manner already described for the forging press, and the water is then admitted to the lower or pressing cylinder, and a pressure to the extent already named is applied. During the application of the pressure copious jets of burning gases escape from the vents around the top and bottom of the mould, whilst ejections of metal

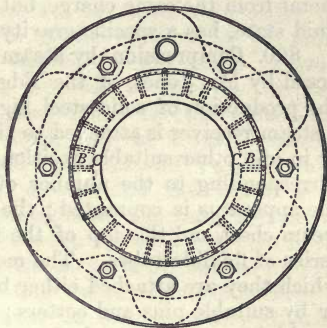

Fig. 97.—Plan of Mould employed in Fluid Compression of Steel.

are also not unfrequent, and under the great pressure which is exerted a fine metallic rain passes through the sand lining of the mould, and collects on the surface of the top plate of the mould around the top plunger. During the operation of compression, the ingot shortens about $1\frac{1}{2}$ inch for each foot of its length compared with the ingot as cast in an open mould; and the *specific gravity* of the fluid compressed metal is likewise greater than that of the uncompressed metal, for whilst steel as cast in the ordinary way containing 0.54 per cent. of carbon has a specific gravity of 7.85 at a temperature of 15° C., the metal from the same charge, but compressed whilst in its fluid state, has a specific gravity of 7.88.

860. Compression by steam pressure has been proposed by Mr. Jones, of the Edgar Thompson Works, for the production of solid steel ingots, and for this purpose a steam receiver is attached to the side of the ingot crane, or in any other suitable position, and is fitted with cocks corresponding to the number of the moulds with which the apparatus is connected; the connections between the steam chest and the top of the moulds being made by a series of flexible tubes. The moulds stand upon bases to which they are attached either by clamps, bolts and lugs, or by suitable pins and cotters; whilst in the top of the mould is a turned conical seat, into which a loose lid coupled to the steam arrangement and provided with a corresponding seating, can be rapidly inserted and wedged down so as to form a steam-tight joint with the mould. The casting operation is conducted by removing the lid or cover from the mould, and attaching in lieu thereof, a runner box, through which the metal is poured until sufficient has been introduced into the mould, upon which the runner-box is removed and the conical cap rapidly inserted, secured in its seating, and the steam, at a pressure of from 80 to 150 or 200 lbs., quickly turned on, the higher pressures being required for the milder steels. The pressure is allowed to act for five minutes or upwards, or until the metal has completely

solidified, under which arrangement ingots of 5 or 6 inches in diameter are said to be shorter to the extent of $1\frac{1}{2}$ inch or 2 inches than those of the same weight cast in the ordinary manner, and the patentee claims that sound ingots are the result; but the difficulty of making a perfectly steam-tight joint with the required rapidity, together with the small pressures practicable, and the greatly increased cost of the moulds, more than counterbalances the advantages, if any, that are attained by the process, and it has accordingly been generally discarded in this country.

861. *Carbonic anhydride* has been substituted by Baron Krupp and others as the medium for obtaining the required pressure, instead of the steam pressure above named. Krupp proposes to use the carbonic anhydride in its fluid state; and for this process the mould is hooped with steel, and the cover is secured to the top of the same by bolts and wedges, whilst the joint between the mould and the cover is at the same time made gas-tight by the insertion of an expanding copper ring between the two. A hole in the top plate through which the metal is introduced into the mould, is closed by a sliding wedge after the surface of the fluid metal in the mould has been covered with sand, slag, or other bad-conducting material. A pipe of small bore forms a communication between the top of the mould and a strong metallic reservoir or flask which contains the fluid carbonic anhydride. The molten metal having been introduced into the mould, communication is then opened between it and the reservoir of carbonic anhydride, the latter being heated or cooled as required, in a cistern of water in which it is immersed, and the pressure exerted upon the molten metal depends upon the temperature to which the carbonic anhydride is thus raised, the pressure or tension of the gas increasing very rapidly as the temperature rises. Instead of the loose cap and casting arrangement as above described, Baron Krupp has also an arrangement for casting from below, through a

riser or passage which can be closed by a conical plug, pressed down into its mouth with the aid of a screw before submitting the metal to the gaseous pressure.

862. The *use of closed-topped instead of the ordinary open-topped moulds* has been proposed for the production of sounder ingots. In using these moulds the metal is poured into a central riser, when it ascends, as already described, from runners opening into the bottom of the other mould; and into the closed moulds a small quantity of combustible materials such as shavings, is sometimes introduced, and these take fire on the entrance of the fluid steel into the mould, and thus generate gas for which there is no exit except by two small holes (three-eighths of an inch in diameter) in the closed top of the mould. In this manner a pressure is maintained on the surface of the metal equal to the head of metal in the riser, whilst further the metal is cast out of contact with the air, since the mould is filled with the products of combustion of the shavings. The author's experience in the use of this class of mould has not, however, been sufficiently satisfactory to lead him to advocate its continuance.

863. For the production of sound castings, such as wheels, &c., the **method of rotation** has also been proposed, for which purpose the moulds are placed upon a turntable, which, as soon as the casting is run, is made to rotate at a speed of from forty to fifty revolutions per minute, and the metal is run into the mould at its centre.

864. Mr. Allen proposes to effect a like purpose by **stirring the steel** contained in a Bessemer ladle with a rotating paddle, which is lowered into the metal before running it in this manner into the moulds; an amount of gas escapes and burns at the surface of the metal during the stirring operation, and sounder ingots are said to result from the treatment.

865. The **production of compound plates** for the purposes of armour has now become a regular manufacture, such plates possessing a tolerably hard steel face which is cast on to a wrought-iron back plate. The compound slab

so produced is directly rolled out when sufficiently cooled into a plate of the thickness and dimensions required, and such plates thus possess a hard face for resisting the penetration of projectiles, whilst the wrought-iron backing prevents the hard steel from breaking up and cracking by the vibration and shock produced by the impact. The manufacture of such plates is effected by connecting a plate or backing of wrought-iron containing about 0·04 per cent. of carbon by means of distance-pieces and steel screws with a face-plate of steel containing about 0·5 per cent. of carbon, thus leaving a clear space between the face- and back-plates, which is closed at either end by the distance-pieces. Into this space the molten steel is introduced for connecting or welding into one slab the hard face, the soft wrought-iron backing, and the mild steel poured between the two. For the production of a slab to be finally rolled into a plate of 8 inches in thickness, the backing of wrought-iron is about 12 inches in thickness, the front plate is about 2 inches thick, and the space between the two plates measures some 5 or 6 inches in width. The proportions of the several parts differ, however, with the thickness of plate under construction, but the mild steel for connecting the inner and outer plates generally forms about one-third of the total thickness in heavy plates, or a little less for the thinner plates.

866. The compound slab is prepared by first heating the face- and backing-plates to redness, and then placing them upright (on edge) in a suitably prepared rectangular moulding-box, sunk into a pit as usual. The plates are placed so that the thick wrought-iron backing-plate stands against one of the iron sides of the moulding-box, whilst the space between the sides of the moulding-box and the back of the steel facing-plate, as also the space at the ends of the plates, is rammed with sand. Into the mould thus prepared the steel from a Siemens open-hearth furnace, is tapped as hot as possible from the ladle into a large trough placed along the length of the plates, and from which the metal runs through several holes or gates

into the space between the two plates. Under these circumstances the heat of the fluid metal is sufficient to so increase the temperature of the surface of the two plates between which it is run that the whole can be withdrawn from the mould as a solid slab which, after being allowed to cool down to redness, is passed at once to the rolls, where it is rolled down to the required dimensions. When the compound plate has become cold, it is removed to a planing machine and cut to the proper size, during which operation the end plates or distance-pieces, and also the screws employed in the preparation of the mould, are removed along with the scrap, and the union between the several constituents of the compound plates, viz., the hard face, mild steel central portion, and soft wrought-iron backing, appears complete.

867. **Mild or soft-centred steel** is such as possesses a hard or more highly carburised surface, enveloping a soft or milder temper of steel in the centre of the ingot or bar. Such a special steel is sometimes employed in the manufacture of engineers' taps, &c., where the working surface is required to be hardened and tempered, whilst it is desirable that the centre should possess the strength and toughness of mild steel. Mild-centred steel is produced by first casting an ingot of mild steel, which is clogged or hammered down and then introduced into the cementation furnace (p. 406), where the bar is converted until the surface has been carburised to the required degree and depth, after which the bars are hammered or rolled down to the sizes required, when the resulting bars possess a hard surface without having lost the toughness of the mild steel centre.

868. The **rolling mills, hammers**, and other machinery employed in the treatment of steel ingots, have been already generally described (p. 346), but the number and variety of the operations performed upon the steel ingot for the production of the finished rail, plate, section, &c., are neither so numerous nor so complicated as those required for the production of the corresponding

product in wrought-iron; while the machinery requires to be generally of a heavier and stronger type for the manipulation of steel than for that of iron.

869. Formerly, it was the invariable practice to hammer all heavy steel ingots under the steam hammer before rolling them into the various forms required in commerce, but the practice is being generally abandoned in the production of such sections as rails, tin-plate bars, &c., &c., for which the ingots are now placed directly in reheating furnaces of the Siemens, Bicheroux, or other type, or the soaking-pits (described on p. 382) may be employed; but in whichever way effected, the heated ingots are then passed at once to the *cogging-mill*, which corresponds to the blooming-mill of the puddling forge. The steel ingots are rolled or cogged into *blooms*, which are then either returned to the reheating furnaces before rolling out into the final section, or if the blooms be intended for rails or like sections, they may be rolled straight off, for the production of three and four rails in a single length by passing the ingot nine times through the different grooves of the cogging-rolls, and then finishing the bloom by thirteen passes through the mill rolls. To reduce the waste arising from crop-ends and other scrap, it has become usual to roll rails in longer lengths, a frequent practice being to roll three or four rails in a single length, and to cut up the same into the required lengths by the hot saw, such a practice requiring the employment of heavier ingots (35 cwts. each) than formerly.

870. For the *manufacture of steel tyres* the ingots are cast in the form of the frustum of a cone of about 20 inches in height if intended for the production of the heavier tyres. This ingot is flattened down under the hammer to half its thickness, when the centre is punched out at the same heat, and the hole so produced is opened out upon the side beak of the anvil block to a diameter of about 20 inches, when the tyre ring, thus roughly formed to the section, is reheated and finished to the section and diameter required upon open-end rolls. In

this class of tyre-mill the rolls are connected with the driving pinions by spindles of 10 or 11 feet in length, so as to allow sufficient freedom between the pinions and the rolls for the great movement necessary to increase the tyre ring to the diameter of the finished tyre. In the roughing rolls the bottom roll is lifted by hydraulic power against the upper roll, whilst in the finishing rolls it is necessary to have three open-end rolls for finishing the section and keeping the tyre more truly circular; but the tyres after they leave the mill require setting in blocks to make them perfectly round and to stretch them to the exact diameter.

871. Steam hammers having a falling weight of 50 and 100 tons are in use for the production of heavy forgings in steel, whilst proportionately smaller hammers are employed for the production of the lighter forgings—blooms, slabs for plates, bars, billets for wire, and the like.

872. The details of the manufacture of steel castings are very carefully kept secret by all engaged in their production, and the author, of course, will not reveal such secrets. Steel castings are prepared from patterns after the usual foundry practice, but instead of being moulded in the ordinary foundry sand, special moulding compositions are employed, and the moulds are always well dried in the stove before the steel is run into them. Various compositions are used as moulding materials. An American mixture consists of calcined quartz, ground to a fine powder and mixed with from 2 to 3 per cent. of glue, water, and flour. This composition is used as the moulding material, but it is faced with a mixture consisting of fine quartz, powder, and a little graphite and water. It is said to yield good castings, having a clean smooth surface. As already mentioned, siliceous pig-iron containing from 6 to 10 per cent. of silicon is often employed in small proportions in addition to ferromanganese for the production of sound castings.

INDEX.

- A**CID lining for Bessemer converter, 462
- Action of acids upon pig-iron, 69
- blast in the blast furnace, 94
 - fluxes in the blast furnace, 103
 - manganese in steel, 388, 393, 395, 433
 - phosphorus on iron, 52, 72, 207, 393
 - — — steel, 393
 - sulphur on iron and steel, 50, 60, 207
- Admiralty tests for steel plates and sections, 399
- Advantages of mild steel, 402
- steel for constructive purposes, 5
- After-blow of the basic steel process, 496, 503, 506
- — — — — Increase of basicity of slag during the, 502
 - — — — — Reactions during the, 499
- Aich-metal, 59
- Aired cementation-bars, 413
- Air-ports of the Siemens open-hearth furnace, 448
- Alfreton blast furnace, 182
- Alligator shears, 348
- squeezer, 301
- All-mine pig-iron, 78
- Alloys of iron, 57
- manganese, 395
 - platinum, 396
 - steel, 394
- Alumina in blast furnace slags, 108
- Aluminum and iron, 61
- steel, 61, 396
- American bloomery process for the production of malleable iron, 222
- rolling mills, 339
- Amount of blast for the blast furnace, 160, 171
- Analyses of basic Bessemer pig-iron, 493, 503
- Bessemer pig-iron, 483
- Analyses of Bessemer slags, 484
- — — steel, 479
 - black-band ironstone, 39
 - blast furnace slags, 107
 - brown hæmatite, 36
 - calcined iron ore, 82
 - cast-iron, 64
 - cinder-pig, 65
 - clay ironstones, 39
 - Dinas clay, 17
 - fettling for the puddling furnace, 260
 - fire-bricks, 22
 - — — clays, 17
 - flue-dust, 159
 - ganister, 22
 - gases from the Bessemer converter, 486
 - — — — blast furnace, 182, 183
 - — — — Siemens gas producer, 370
 - — — — Wilson gas producer, 370
 - Heaton products, 442
 - iron ores, 32
 - magnesite bricks, 495
 - magnetic iron ores, 32
 - malleable iron, 205
 - — — — from the Siemens rotator, 217
 - metal at different stages of basic process, 498, 499
 - — — — — Bessemer blow, 479
 - — — — pig-iron, 64, 65
 - — — — — for basic process, 493, 503
 - — — — — Bessemer process, 483
 - — — products of "Transfer Method" of the basic process, 504
 - — puddled steel, 438
 - — red hæmatite iron ores, 34
 - — refined iron, 244
 - — refinery cinder or slag, 244
 - — silica bricks, 22
 - — silico-manganese-melting, 508
 - — silicon steel, 394, 508
 - — slags from the basic process, 501, 502

- Bessemer skulls, 465, 477
 — slag-pit, 470
 — slags, 483
 — steel, 479
 — — before adding spiegel, 479
 — — ingot, Section of, 506
 — vessel or converter, Decomposition in, 475, 478
 — — — — Elevation of, 464
 Best-iron, 209, 210
 — best-iron, 209, 210
 — Staffordshire, 210
 — tap, 261
 Better-bed coal, 270
 Bicheroux furnace, 280, 361
 — reheating furnace, 378
 Billeting rolls, 325
 Billets, 324
 Birmingham wire-gauge, 211
 Bispberg iron-ores, 32
 Black-band iron-ores, 37, 83
 — plates, 211
 Blaenavon blast furnace, 178
 Blake's stone crusher, 80
 Blank charges for the blast furnace, 134
 Blast, Amount of, for blast furnace, 128, 160, 171
 — Effect of, in the blast-furnace, 94
 — Influence of, upon make of iron, 171
 — Pressure of, 94, 163, 171, 172
 — — for Bessemer process, 462, 475
 — Volume of, for the blast furnace, 171
 — furnace, 111
 — — Anthracite, 114, 170, 179
 — — Belgian, 112, 178
 — — Best form of, 113, 115
 — — Blaufen, 133
 — — Blowing in of a, 139
 — — — out of a, 139
 — — Boshes of, 111, 116
 — — Buttgenbach's, 138
 — — Charcoal, 112, 124, 133, 135, 179
 — — Charges of the, 177
 — — Charging apparatus for the, 175, 176
 — — Chemical reactions in the, 94
 — — Cleveland, 111, 113
 — — Cupola, 111, 118
 — — Derangement of the, 141, 142
 — — Fluxes for the, 104
 — — Forms of the, 111
 — — French, 212
 — — Fuels for, 168
 — — gases, Composition of, 96
 — — Hearth of the, 111
 — — Height of the, 113, 114
 — — Modern, 111
 — — Old, 111, 116, 118
 — — Open-topped, 116
 Blast furnace, Rchette, 136
 — — Reducing agents in the, 94, 95
 — — Reduction of phosphoric anhydride in, 102
 — — Scotch, 111
 — — Slags from, 14, 107
 — — Stack of, 111
 — — Staffordshire, 111, 116
 — — Sulphur in slags from, 98, 102
 — — Swedish, 135
 — — Throat of, 127
 — — Twyers of, 126
 — — Varieties in the dimensions of, 112
 — — Waste-gases from the, 181
 — — Working of the, 171, 175
 — — Yield of the, 102, 175, 179
 — — Zones of the, 100
 — — main, 119, 125
 — — regulator, 163
 Blaufen blast furnace, 133
 Blazed pig-iron, 55, 73, 78
 Blister steel, 411, 412
 — — Cause of blisters on, 413
 — — Charges of, for crucibles, 421
 Blooming process for the production of malleable iron, 222
 Blooming machinery, 300
 Blow-holes in iron-castings, 189
 Blowing engines, 143, 160
 — — for the Bessemer process, 489
 — — in a furnace, 139
 — — out a furnace, 139
 Blue Billy, 52, 249, 259, 292
 Board of Trade and the use of steel, 402
 Body in steel, 395
 Boëtius furnace, 361
 — reheating furnace, 378
 Bog iron-ore, 36
 Boiling of mild steel in the ingot-mould, 507
 — stage of Bessemer process, 475
 — — puddling process, 264
 Boshes of the blast furnace, 116
 Bottom, Basic, in melting furnace, 446
 — for basic-lined converter, 505
 — of Siemens melting furnace, 446
 Bowling iron, 208, 268
 Brands of bar-iron, 431
 Brasqued crucibles, 24
 Breaking-pieces for rolls, 322
 Breast-hole in cupola, 190
 — plate in cupola, 190
 Bricks, Bauxite, 16
 — Dinas, 19, 20
 — Fire-, 18, 22
 Bridle for holding test-pieces, 3
 Brook and Wilson's gas producer, 367

- Brown Hæmatite, 35
 — iron-ore, 35
 Brown's squeezer, 303
 Bull dog, 56, 249, 259, 260, 292
 — — slag, 56
 Burden of the blast furnace, 102
 Burnt iron, 206
 — sand, 196
 — steel, 391
 Buttgenbach's blast furnace, 138
- CADDICK** and Maybery's puddling furnace, 273
 Calcareous ores, Treatment of, in the blast furnace, 105
 Calcination, 10
 — between closed walls, 87
 — in kilns, 84, 88
 — — open heaps, 84
 — Loss of weight in, 83
 — of iron-ores, 81
 — — pyritic ores, 82, 86
 Calcined iron-ore, Analyses of, 82
 Calciner, Swedish, 91
 Calcining kilns, 84, 83
 Calorific power of phosphorus, 503
 Carbide of iron, 49
 Carbon and iron, 46
 — in mild-steel, 397
 — — pig-iron, 48
 — — steel, 384, 398
 Carbonate of iron, 49
 Carbonic oxide as a reducing agent, 94
 Carburisation methods of producing steel, 403, 430
 Carinthian gas-furnace, 382
 — — — Method of producing steel in, 433, 434
 — puddling furnace, 275
 Case-hardening, 47, 144, 206
 Casson-Bicheroux furnace, 379, 380
 — gas-producer, 361, 367, 379
 Casting ladle, Bessemer, 469, 472
 — of ingots in groups, 473
 — — large ingots of crucible steel, 426
 — pit, The Bessemer, 469
 Castings for malleable cast-iron, 283
 — in chills, 198
 — — dry sand, 197
 — — green sand, 197
 — — iron, 187
 — — loam, 197
 — Steel, 518
 — Strength of, 186
 Cast-iron, 47, 61
 — — Action of acids upon, 69
 Cast-iron, Analyses of, 64
 — — Commercial classification of, 75
 — — Effect of fusion upon, 70
 — — Grey, 49, 63, 68
 — — Malleable, 282
 — — Mottled, 48, 63, 66
 — — Nitrogen and, 385
 — — Phosphorus and, 72
 — — Silicon and, 67, 72
 — — Strength of, 70
 — — Sulphur and, 71
 — — Varieties of, 63
 — — White, 49, 63
 — or crucible steel, 406, 415
 — steel melting furnace, 417
 Catalan forge, Production of steel in, 403
 — furnace, 218
 — process for the production of malleable iron, 217
 — trompe, or blowing machine, 218
 Caustic lime, Use of, in blast-furnace, 106
 Cementation, 11
 — furnace, Vertical section of, 407
 — process for the production of steel, 406
 — — Bars for the, 409
 Centimetre, 2
 Charcoal blast furnace, 113, 124, 133, 135, 179
 — finery, 230
 — for cementation process, 410
 — — crucible steel process, 431
 — plates, 223
 Charge, Dropping of, in puddling, 262
 Charges for the blast furnace, 177
 — — cementation furnace, 410
 — — crucibles, 421, 426, 427
 — — Danks furnace, 292
 — — open-hearth steel furnace, 456
 — — Pernot furnace, 451
 — — puddling furnace, 268
 — — Siemens-Martin process, 449
 — — steel puddling process, 435
 Charging of the blast furnace, 176
 — — foundry cupola, 192
 Chemistry of iron, 40
 Chenot process for the production of malleable iron, 225
 — — — — steel, 405
 Cherry-red heat, 8
 Chilled castings, 198
 — cast-iron, 49, 68
 Chromium and iron, 58
 — — steel, 388, 396
 Cinder-bottom of the puddling furnace, 296
 — -fall, 131
 — Finery, 232, 244

- Cinder, Flue, 360
 — from puddling of steel, 439
 — -notch, 117, 131
 — -pig, 56, 65, 78, 83, 110
 — -plate, 322
 — Refinery, 243, 244
 — Tap, 14, 56, 266, 279, 280
 — tub, 131
 Circular hot-blast stove, 147
 Clay ironstones, 37, 38
 — — Analyses of, 39
 — — Pig-iron from, 37, 40
 Clays, 14
 — Fire-, 17
 — — Plasticity of, 14
 — — Tempering of, 419
 Cleveland blast furnace, 111, 113
 — ironstone, 37, 39
 Close-topped ingot-moulds, 514
 Coal as fuel for blast furnace, 170
 — for cementation process, 412
 — — gas-producers, 369
 Cobalt and iron, 61
 Cogging mill, 517
 Coke as fuel for blast furnace, 169
 — -plates, 230
 — -refinery, 230
 Colcothar, 44
 Cold-rolling of iron and steel, 4, 5
 — — — steel, 387
 — — shortness in iron, 9, 53, 60, 207
 — — — steel, 9, 393
 — — shots in iron-castings, 189
 Collaring in the rolls, 326
 Columbian iron-ore, 32
 Combined Siemens and Bessemer
 process, 453
 Coming to nature, 264, 272
 Commercial classification of bar-
 iron, 209
 — — — pig-iron, 75
 Composition of blast-furnace gases,
 96
 — — gas-producer gases, 370
 — used in moulds for steel castings,
 513
 Compound armour plates, 514
 Compressed air lifts, 167
 Compression of steel, 512
 — — — by carbonic anhydride, 513
 — — — — steam pressure, 512
 Conduct of the Bessemer process,
 474
 Consumption of coal in the produc-
 tion of merchant bars, 361
 — — — — — puddled bars,
 360
 — — coke in steel-melting, 426
 — — fuel in the blast furnace, 169
 — — — — puddling of steel,
 438
 Conversion of grey into white-iron
 by chilling, 68
 — — — — — in the refinery, 238
 — — pig-iron into malleable iron in
 open-hearths, 212, 228
 Converted bars, 412
 Converter, Bessemer, 462, 464
 — — for the basic process, 493
 — Fixed Bessemer, 462
 — Heaton, 441
 Converting furnace, 406
 Copper and iron, 59
 — — pig-iron, 173
 — — steel, 59, 396
 Cores, 202
 Corrosion of iron, 205, 388
 — — steel, 337
 Coupling boxes for rolling mills
 321, 323
 Cowper's hot-blast stoves, 151
 Crampton's puddling furnace, 295
 Crane, Bessemer hydraulic, 469
 Crocodile shears, 348
 — squeezers, 301, 302
 Cropping shears, 343
 Crucible-moulds, 27
 — Cast-steel, 415, 426
 — — —, Consumption of coke in
 production of, 426
 Crucibles, 24, 419
 — Annealing of, 420
 — Brasqued, 24
 — Cornish, 24
 — French, 24
 — Hessian, 24
 — London, 24
 — Plumbago, 29, 426, 430
 — Steel-melting, 24, 419, 426
 Crude steel, 441
 Crystallisation in cylinders of cast-
 iron, 188
 — — flat plates of cast-iron, 187
 Cubic pyrites, 52
 Cup and cone for blast furnaces, 115,
 121, 176
 Cupola blast furnace, 111, 118
 — for melting spiegeleisen, 470
 — — the Bessemer process, 470
 — foundry, 189, 193

DAMASKEENING, 393
 — Dam-plate, 117
 — -stone, 117
 Dandy in puddling furnace, 276
 Danks furnace, 2-3
 — revolving puddling furnace, Ver-
 tical section of, 288
 — -Winslow squeezer, 306
 Dannemora brands of bar-iron, 431

Dannemora iron, 235
 — iron ore, 32
 Dead-melting of steel, 425, 507
 — — — in open-hearth furnace, 458
 — — weight test for rails, &c., 401
 Decarburisation methods for the production of steel, 403
 Decomposition in the Bessemer converter, 475, 478
 Definition of ductility, 3
 — — elasticity, 4, 5
 — — malleability, 6
 — — steel, 385
 — — tenacity, 1
 Deflection of rails, 401
 Detmore's puddling furnace, 275
 Devonshire iron-ore, 32.
 Dimensions of blast furnaces, 113
 Dinas clay, Analysis of, 17
 — fire-bricks, 19, 20
 Direct basic Bessemer process, 506
 — Bessemer process, 471
 — process for the production of malleable iron, 211
 — — Siemens, for the production of malleable iron, 213
 — — — — — steel, 406
 — reduction of iron ores for steel, 402, 403
 Distribution of heat in the blast furnace, 101
 Disulphide of iron, 52
 Dolomite, 106, 495
 Double bullet bar iron, 431
 — puddling furnace, 270, 277
 — shear steel, 411, 414
 — squeezer, 302
 Doubles, 211
 Drawing the heat in the cementation process, 411
 Dropping of the charge in puddling, 262, 264
 — — flame in the Bessemer process, 476
 Dry-bottom for puddling, 274
 — puddling, 238, 249, 252, 267, 271
 — sand castings, 197
 Drying in puddling process, 272
 Ductility of metals, 3
 — — — Effect of carbon upon, 3
 — — — — — heat upon, 3
 — — — — — silicon upon, 3
 Dull-red heat, 8

EASTWOOD'S mechanical rabble, 286
 Economy of fuel in the blast furnace, 174

Effects of hammering or rolling steel, 397
 — — other metals on pig-iron, 73
 — — wire-drawing, 387, 397
 Elasticity, Limit of, 4, 5
 — — — in steel, 399
 — of metals, 4
 — — steel, 397, 400
 Elevation of blowing engine, 162
 — — puddling furnace, 254
 — — Rchette furnace, 137
 — — Refinery, 239
 Elimination of phosphorus in basic Bessemer process, 500
 — — — puddling, 253
 — — sulphur in the basic process, 253
 — — — silicon and phosphorus in the open-hearth processes, 458
 Ellerhausen's process for the production of steel, 444
 Engines, Blowing, 143, 160
 — — for Bessemer process, 489
 — Rolling mill, 340
 Extension of the metal in plate-rolling, 334
 Eye of furnace, 126

FAHLUN blast furnace, 136
 — Falling-weight test for rails, &c., 401
 Farnley iron, 268
 Fatigue of metals, 6
 Feeder, 129
 Feeding-gates, 201
 Feed-rolls, 338
 Ferric acid, 46
 — anhydride, 46
 — disulphide, 50, 52
 — oxide, 44
 — — Hydrated, 45
 — sulphide, 50.
 Ferrous carbonate, 49
 — silicate, 55
 — — Roasting of, 83
 — sulphide, 50, 51
 Ferromanganese, 58, 75, 78, 99
 — Use of in the Bessemer process, 480
 Ferry-hill blast-furnace, 113
 Fettleing, 252, 256, 259, 260, 290
 Fillifer's calcining kiln, 91
 Fine-metal, 245
 Finery, 229, 230
 — -cinder, 232, 244
 — for the production of steel, 433
 — process, 229
 Fining, 11
 — stage of the Bessemer process, 475

Finishing rolls, 323, 325
 Fire-bricks, 18
 — Analyses of, 22
 — Dinas, 19, 20
 — Glenboig, 22
 — Newcastle, 22
 — Silica, 21, 22
 — bridge of the puddling furnace, 255
 — clays, 17
 — Analyses of, 17
 — The hollow, 230, 233
 Firestones, 23
 Firing-hole of the puddling furnace, 257
 Fix, for the Danks furnace, 290
 Fixed Bessemer converter, 462, 471
 Flame from the Bessemer converter, 475, 486
 Flask and plug for crucible making, 25, 27
 Flexibility of steel, 400
 Floating of solid on fluid pig-iron, 68
 Flow-gates, 201
 Flue-bridge of the puddling furnace, 255
 — cinder or slag, 360
 — dust, 159, 185
 Fluid compression of steel, 510
 Fluidity of blast furnace slags, 109
 Fluorine steel process, 442
 Flux, 11, 103
 — Nature and quantity of, 104
 Fore-hearth of the blast furnace, 117
 — plate for rolls, 322, 326
 Forest of Dean iron-ores, 36
 Forge, 300
 — iron, 51, 57
 — scale, 14, 56, 206
 — tests for steel, 399
 — of malleability, &c., 6, 401
 — train for rolling puddled bars, 319
 Forging presses, 315
 Forms of blast furnace, 111
 Formula of blast furnace slags, 14, 106
 — refinery slags, 14, 243
 Foundations for steam hammers, 314
 Foundry appliances, 185
 — Cupola, 189, 190, 193
 — iron, 53, 66, 76, 186
 — sand, 196
 Four-high rolls, 337
 Franklinite, 33
 French Admiralty tests for steel, 399
 Frontal helve, 308
 Fuel for the blast furnace, 168
 — cupola foundry, 193
 Furnace, Alfreton, 182

Furnace, Annealing, 420
 — Baling, 356
 — Blast, 111
 — Action of the, 94
 — Blaufen, 133
 — Bloomery, 222
 — Blowing in a, 139
 — Carinthian gas, 382
 — Catalan, 218
 — Cementation, 406
 — Charges of, 177, 268, 292, 410, 421, 426, 427, 435, 449, 452, 456
 — Cleveland blast, 111
 — Converting, 406
 — Cupola blast, 111
 — Danks puddling, 288
 — Eye of, 126
 — Gas, 361, 363
 — High bloomery, 225
 — "In-blast," 93
 — Melting, 417, 429
 — Mill, 356
 — Open-hearth steel-melting, 445
 — Pernot, 297, 451
 — Ponsard, 278, 361, 380, 452
 — Puddling, 255, 270, 275, 276, 276, 277, 280, 288, 294, 295, 297
 — for steel, 435
 — Rchette, 136
 — Refinery, 239
 — Reheating, 355
 — Scotch blast, 111
 — Siemens melting, 428, 445
 — regenerative, 371
 — reheating, 371
 — rotary, 213
 — Staffordshire, 110
 — Steel-melting, 417, 429
 — Stückofen, 225
 — tops, 121, 124, 125
 Fusibility of blast furnace slags, 109

GALVANISING of iron, 59

— Gangue, 10
 — of iron ores, 93
 Ganister, 123
 — Analyses of, 22
 Gas furnaces, 361, 363
 — Advantages of, 363
 — Bicheroux, 280, 361
 — Boëtius, 378
 — Carinthian, 382
 — Ponsard, 278, 361
 — Siemens regenerative, 361, 371
 — ports of the open-hearth steel-melting furnace, 448
 — producers, 362
 — Brook and Wilson's, 367
 — Casson's, 367

Gas producers, Fuel for, 362
 Gases, Composition of blast furnace,
 182, 183
 — from Bessemer converter, 485
 — — Siemens producer, 369
 — — — — Analyses of, 370
 — — soaking pits, 383
 — occluded by steel, 392, 507
 Gates, 201
 — Pouring, 201
 Gjer's calcining kiln, 89
 — pneumatic lift, 167
 — soaking pits, 382
 Glamorganshire iron ores, 36
 Glazed bars, 413
 — pig-iron, 55, 73, 78, 99
 Glenboig fire-bricks, 22
 Gold and iron, 61
 Goose-neck, 126, 472
 Göthite, 36, 45
 Grades of pig-iron, 76
 Granite, 23
 Graphite in iron, 48, 62
 Green-sand castings, 197
 Grey pig-iron, 48, 63, 98, 102
 Gridiron brand of bar iron, 431
 Griffiths' mechanical rabble, 287
 Group casting of steel ingots, 473
 Guide-iron, 326
 — -jaws, 326
 — -train of rolls, 326
 Guillotine shears, 348, 351

HÆMATITE, Brown, 35

— — Analyses of, 36
 — Red, 33
 Hammers, 307
 — Helve, 307, 308
 — -scale, 42, 43
 — Shingling, 300
 — -slag, 42, 43
 — Tilt, 307
 Hardening of steel, 388
 Haswell's forging press, 315
 Hearth, Blast furnace, 111, 115, 117,
 132
 — Swedish-Lancashire, 233
 Heat, A, in puddling, 266
 — — — balling furnace, 359
 — — — Bessemer process, 480
 — -producers in basic process, 503
 Heating-power of the gases from
 the Bessemer converter, 480, 486
 Heaton converter, 441
 — process for the production of
 steel, 440
 — products, Analyses of, 442
 Height of the blast furnace, 113

Helve, Shingling, 308
 Henderson's process for the produc-
 tion of steel, 442
 Hessian crucible, 24
 High bloomery furnace, 225
 Hoists, 143, 164
 Holley's movable bottom for the
 Bessemer converter, 467, 468
 Hollow Fire, The, 230, 233
 Honeycomb structure in steel
 ingots, 424, 507
 Hoop L bar-iron, 431
 — F bar-iron, 431
 Horizontal rotary squeezer, 304
 Horse, 143
 Hot-blast, Advantages of, 174
 — — iron, 69, 77, 173, 179
 — — pipes and the fracture of, 151
 — — stove, 143, 144
 — — — Circular, 147
 — — — Cowper's, 151
 — — — Massick's, 148, 159
 — — — Pistol pipe, 149
 — — — Rectangular, 145
 — — — Regenerative fire-brick, 151
 — — — Westphalian, 150
 — — — Whitwell's, 155
 — — Temperature of, 143, 155, 158,
 173, 178
 — — Twyer, 126
 — — Use of, 173
 Housings for rolls, 321
 Hydrated ferric oxide, 45
 Hydraulic casting press, 511
 — forging process, 315
 — lifts, 166
 — squeezer, 307

ILMENITE, 36

Incipient redness, 8
 Inclination of twyers in the blast
 furnace, 127
 Inclined plane, The, 164
 Indirect process for the production
 of malleable iron, 212, 228
 Ingot-iron, 384, 385, 461
 — -moulds, 423
 — — Preparation of, 423, 427
 Iron, Alloys of, 57
 — Aluminum and, 61, 208
 — Antimony and, 60
 — Carbide of, 49
 — Carbon and, 46, 48
 — Carbonate of, 49
 — Chromium and, 58
 — Cobalt and, 61
 — Cold-blast, 69, 70
 — — -short, 9, 53, 60, 207

Iron, Copper and, 59
 — Dannemora, 235
 — Direct reduction of malleable, 211
 — Disulphide of, 52
 — Fuel used in smelting, 114
 — Galvanised, 59
 — -glance, 33
 — Gold and, 67
 — Grey pig-, 49, 63, 98
 — Hot-blast, 69, 77, 173, 179
 — Lead and, 61
 — Low Moor, 208, 268
 — Malleable, 202
 — Manganese and, 58
 — Merchant bar-, 209, 343
 — Metallic, 40
 — Meteoric, 31
 — Mottled cast-, 48, 63, 66
 — -moulds, Preparation of, for the reception of the steel, 423, 427
 — Native, 31
 — Nickel and, 60
 — Nitrogen and, 57, 385
 — Occlusion of gases by, 41, 67, 392
 — ores, 30
 — — Analyses of, 32
 — — Bispberg, 32
 — — Brown, 35
 — — Calcination of, 81
 — — Clay ironstone, 37, 38
 — — Lenticular, 34
 — — Magnetic, 31
 — — Oural, 32
 — — Persberg, 32
 — — Phosphorus in, 53
 — — Preparation of, 80
 — — Red hæmatite, 33
 — — Roasting of, 81
 — — Self-fluxing, 104
 — — Smelting of, 92
 — — Spathic, 37
 — — Titaniferous, 79
 — — Weathering of, 80
 — Oxides of, 43
 — Oxygen and, 43
 — Passive condition of, 43
 — Phosphorus and, 52, 72, 207, 393
 — -plates, 209, 210
 — Platinum and, 61
 — Puddling of, 11, 248, 254
 — Pure, 1, 40
 — -pyrites, 52, 86
 — Red-shortness of, 51, 60, 207
 — Rusting of, 42, 45
 — Silicates of, 31
 — Silicon and, 54, 207
 — Silver and, 61
 — -smelting in Japan, 139
 — Specific gravity of, 41

Iron Specular, 33
 — Sulphides of, 31
 — Sulphur and, 50, 71
 — Tin and, 59, 60, 208
 — Titanium and, 208
 — Tungsten and, 58
 — Welding of, 7, 55, 204, 387
 — White, 48, 98
 — Wrought, 202
 — Zinc and, 59, 208

JAPAN, Iron-smelting in, 139
 Jerking strains, Effect of on steel, 401

KAOLIN or China clay, 26
 Kidney iron ore, 34
 "Killed," in crucible steel-melting, 425
 Kilns, Calcining, 84, 88
 Kilogramme, 2
 Kish, 49, 69
 Krupp's washing process, 246

LADLE, Bessemer casting, 469, 472
 Lake-ore, 36
 Lancashire hearth, 233
 Langen's blast furnace top, 124
 Lattens, 211
 Lead and iron, 61
 Ledebur, Prof., on welding, 7
 Lenticular iron ore, 34
 Letting-down of steel, 389
 Liitts, 143, 164, 165
 — Perpendicular, 165
 Lime, 15
 — in blast furnace slags, 108
 — — the basic Bessemer process, 505
 — Use of in the Styrian furnaces, 16
 Limestone as a flux, 104
 — Fossiliferous, 105
 Limit of elasticity in steel, 400
 Limonite, 36, 45
 Lining of Bessemer converter, 467
 — — — Basic, 494
 — — — Danks furnace, 291
 — — — Second, for Danks furnace, 291
 Lloyd's fans, 194
 — tests for steel plates, 399
 Loam, 197
 — Castings in, 197
 Loss in calcination of iron ores, 84
 — — puddling process, 267, 268
 — — rolling of steel, 361

Loss in Siemens-Martin process, 451
 Low Moor iron, 208, 268
 Lurman's closed hearth, 132

MAGNESIA, 15

— Magnesite, 15
 — bricks, 16, 495
 Magnetic iron, Analysis of, 32
 — ore, 31
 — oxide, 43
 — pyrites, 52
 Magnetite, 31, 44
 Maintenance of a uniform pressure of blast, 163
 Make of iron in the blast furnace, 103, 136, 174, 179
 Malleability, Definition of, 6
 — of iron, 7, 204
 Malleable cast-iron, 282
 — iron, 202
 — Analysis of, 205
 — castings, 282
 — Cold-short, 9, 53, 60, 207
 — Commercial varieties of, 203, 209
 — Corrosion of, 205
 — Direct production of, 211
 — Ductility of, 204
 — Indirect production of, 228, 248
 — Malleability of, 7, 204
 — Melting point of, 204
 — Phosphorus and, 207, 393
 — Production of, direct from the ore, 211, 213, 217, 222, 225
 — from pig-iron, 212, 228, 248
 — in India, 432
 — steel by carburisation of, 406
 — Red-shortness in, 51, 60, 207
 — Silicon and, 207
 — Specific gravity of, 205
 — Strength of, 208, 209
 — Sulphur and, 51, 207
 — Transverse strength of, 400
 — Welding of, 7, 55, 204
 Mallett on buoyancy of cast-iron, 166
 Manganese, Action of, in steel, 388, 393, 395, 433
 — the open-hearth furnace, 459
 — the basic process, 504
 — Alloys of, 394
 — in blast furnace slags, 108
 — pig-iron, 74, 98
 — puddling process, 254
 — Iron and, 58, 74
 — Malleable iron and, 204

Manipulation of the puddling process, 261
 Manufacture of crucibles, 25
 — — tyres, 517
 Marcasite, 52
 Massicks and Crookes' hot-blast stove, 148, 159
 Mechanical puddling, 285
 — rables, 285
 — Eastwood's, 286
 — Griffith's, 287
 — Morgan's, 287
 — Pickles', 286
 — Whitham's, 278, 287
 — treatment of the puddled ball, 300, 301
 Melting-down refinery, 242
 — furnace, 417
 — Siemens, 429, 445
 — heat, or No. 6 temper of blister-steel, 411
 — holes, 417
 — house or furnace, 416
 — of cast-steel, 415
 — steel in reverberatory furnaces, 429
 — point of cast-iron, 66
 — malleable iron, 204
 — pure iron, 41
 — steel, 387
 — stage of puddling, 261
 Merchant iron, 209
 — Consumption of fuel in production of, 360
 — Piling for, 343
 Metallic sponge from the Chenot process, 404
 Metallurgical terms, 1
 Meteoric iron, 31
 Micaceous iron ore, 33
 Mild centred steel, 516
 — steel, 385, 397
 — Advantages of, 402
 — Unsoundness of, 506
 Mill, 300
 — cinder, 56, 360
 — furnaces, 356
 — rolls, 320
 Mills, Belgian rolling, 336
 — Four-high, 337
 — Reversing, 326, 332
 — Rolling, 324
 — Three-high, 326, 327
 Millstone-grit, 23
 Mine, 10, 56
 — and cinder pig, 56
 Mixtures of iron for foundry use, 186
 Mopping of crucibles, 423
 Morgan's mechanical rabble, 287
 Mottled pig-iron, 48, 63, 66

- Moulds, Bessemer, 473
 — for the fluid compression of steel, 510, 512
 Mundic, 52
- N**AILED rods, 210
 Native iron, 31
 — steel, 31
 Natural steel, 404
 New South Wales iron-ores, 36
 Nickel, Iron and, 60
 Nitrogen, Cast-iron and, 385
 — Iron and, 57, 385
 — Steel and, 57, 384
 Nodding, 11, 269
 North Lonsdale blowing engines, 163
 — iron-ores, 35
 Northamptonshire iron ores, 36
 Nose-helve, 308
- O**CCLUSION of gases by iron, 41
 — — — — pig-iron, 67
 — — — — steel, 392
 Oil-hardening, 391
 Open-hearth and Bessemer steel processes, Combined, 453, 454
 — steel, 445, 447, 456
 — — — — melting furnace, Siemens, 445
 — — — — Longitudinal section of, 447
 — — — — Transverse section of, 447
 Ores, Dressing of, 84
 — Iron, 30
 — Production of steel direct from the, 402, 403, 406
 — Self-fluxing, 104, 136
 Ovens, Blast, 143
 Overblown Bessemer metal, 478
 Overblow of the basic Bessemer process, 496, 506
 Oural iron ores, 32
 Output of the blast furnace, 180
 — — — Bessemer plant, 487
 Oxides of iron, 43
 Oxygen, Iron and, 43
- P**ARRY'S process for the production of steel, 281
 — — of double puddling, 281
 Passive condition of iron, 42
 Peeler, 358
- Persberg brands of bar iron, 431
 — iron ore, 32
 Pernot revolving furnace, 297, 451
 Perpendicular lifts for the blast furnace, 165
 Phosphorus, Bar-iron and, 207, 393
 — Calorific power of, 503
 — Cast-iron and, 72
 — Conditions for removal in basic process, 500
 — Elimination of, in the puddling process, 253, 267, 271, 281
 — Iron and, 52, 72, 207, 393
 — Reduction of, in the blast furnace, 53, 97, 102
 — Steel and, 393
 Physics employed in steel melting, 432, 439
 Pickles' mechanical rabble, 286
 Pickling of plates, 388
 Pig-bed, 129
 — -boiling, 11, 248, 252, 259, 267
 — Forge, 51, 57
 — -iron, 61
 — — Action of acids upon, 69
 — — All-mine, 78
 — — Analyses of, 64, 65
 — — Bessemer, 73, 461, 482
 — — Blazed, 55, 73, 78
 — — Cinder-, 78
 — — Classification of, 75
 — — Conversion of, into malleable iron in open-hearths, 212, 228
 — — Copper and, 73
 — — Crystalline forms of, 63
 — — Effects of other metals upon, 73
 — — from clay ironstone, 492
 — — — Cleveland ores, 51, 492, 503
 — — for the basic process, 492, 502
 — — Foundry, 50, 66, 76
 — — Glazed, 55, 73, 78, 99
 — — Grades of, 77
 — — Grey, 49, 63, 98
 — — Manganese and, 58, 74, 98
 — — Melting-point of, 66
 — — Mine and cinder, 78, 83
 — — Mottled, 48, 63, 66
 — — Occlusion of gases by, 67
 — — Phosphorus and, 72
 — — Production of, 79
 — — Refining of, 238
 — — Silicon and, 67, 72, 99
 — — Specific gravity of, 63
 — — Strength of, 71
 — — Sulphur and, 50, 71
 — — Tin and, 74
 — — Titanium and, 73
 — — White, 49, 63, 98
 Pigs, 130
 — Swedish, 130

- Piles for rolling, 324
 Piling for best-iron, 210
 — merchant iron, 343
 — plates, 344
 — rails, 344
 Pipe in hard steel, 506
 — stoves, 144
 — Disadvantages of, 151
 — Westphalian, 135
 Piping of steel ingots, 392, 424, 506
 Pistol-pipe hot-blast stove, 149
 Plane, Inclined, 164
 Plan of bed of converting furnace, 408
 — — — puddling furnace, 255
 — — — refinery, 240
 Plate-metal, 245
 — mills, 320, 333
 — shears, 349
 Plates, Piling for, 344
 — Strength of, 209
 Platinum and iron, 61
 — steel, 61, 396
 Plug-holes in the gas producer, 365
 Plumbago crucibles, 29, 426, 430
 Pneumatic lifts, 167
 — process for the production of steel, 460
 Ponsard gas-furnace, 278, 361, 380, 452
 — producers, 367, 380
 — recuperator, 380
 Potassic iodide, a physic for steel, 433
 Pottery-mine, 260, 261
 Pouring gates, 201
 Preparation of iron-ores, 80
 Press for compressing fluid steel, 511
 Pressure of blast for the Bessemer converter, 462, 475
 — — — blast furnace, 171, 172
 Price's puddling furnace, 276
 Process of fluid compression of steel, 510
 Producer, The gas, 362
 Production of heavy cast-iron castings, 195
 — homogeneous steel ingots, 506
 — malleable iron direct from the ore, 211, 213, 217, 222, 225
 — — — from cast or pig-iron, 212, 228, 248
 — pig-iron, 79
 — sound steel ingots by pressure, 509
 — — — — rotation, 514
 — — — — stirring, 514
 — steel by the carburisation of malleable iron, 406, 430
 Production of steel by the fusion of bar-iron with charcoal, 430
 — — — — — pig-iron with malleable iron, 445
 — — — — — decarburisation of pig-iron, Methods for the, 403, 433
 — — — — — direct from the ore, 402
 — — — — — Methods for the, 402
 — — — — — Parry's process, 281
 Puddled ball, Forge train for the rolling of, 319
 — Mechanical treatment of, 300, 301
 — bar, 209, 324
 — Consumption of fuel in the production of, 360
 — steel, 434
 — Analyses of, 438
 Puddler's mine or ore, 34, 259
 Puddling, 11, 248, 254
 — Dry, 238, 249, 252
 — Furnace, 255
 — Bicheroux, 280
 — Caddick and Maybery's, 273
 — Carinthian gas, 275
 — Crampton's, 295
 — Danks, 288
 — Detmore's, 275
 — Double, 270, 277
 — Elevation of, 254
 — for steel, 435
 — Gas, 273
 — Pernot's, 297
 — Plan of bed of, 255
 — Price's, 276
 — Siemens, 273, 288
 — Spencer's, 294
 — Vertical section of, 254
 — Loss in, 267, 268
 — Mechanical, 285
 — Methods of, 249
 — Parry's double, 281
 — process, 248, 250, 435
 — — — — — Balling stage of, 262, 264
 — — — — — Boiling stage of, 262, 264
 — — — — — Dry, 249, 252, 267, 271
 — — — — — Elimination of phosphorus in, 253, 267, 271, 281
 — — — — — sulphur in, 253
 — — — — — Manipulation of, 261
 — — — — — Melting-down stage of, 261
 — — — — — Wet, 248, 252, 267
 — Reactions in, 249
 — rolls, 319
 — tools, 280
 Pullers-out, 422
 Pulpit of Bessemer plant, 469
 Pure iron, 1, 40
 Purple iron-ore, 260
 Pyrites, Cubic, 52
 — Magnetic, 52

- Pyrites, White-iron, 52
 — Yellow, 52
 Pyritous ores, Roasting of, 86
 Pyrrhotine, 52
- RACHETTE** furnace, 136
 Rail ingots, 473
 — rolling, 338, 516
 — tests, 399, 400, 401
 Rails from the Siemens-Martin process, 451
 — Piling for, 344
 Ramsbottom's duplex steam hammer, 315
 Raw steel, 433
 Reactions in the Bessemer converter, 475, 478
 — — — blast furnace, 94, 96
 — — — Catalan furnace, 221
 — — — open-hearth steel-melting furnace, 458
 — — — puddling furnace, 249
 — — — refinery, 243
 Rectangular hot-blast stove, 144
 Recuperator, Ponsard's, 380
 Red hæmatite, 33
 — Analyses of, 34
 — ochre, 34
 — shortness in iron, 9, 51, 59, 60, 71, 207
 — — — steel, 51, 394, 395
 Reducing agent, 10
 — in the blast furnace, 94, 95
 Reduction, Definition of, 10
 — of ferric oxide by carbonic oxide, 96
 — phosphorus in the blast furnace, 53, 97, 102
 — silicon in the blast furnace, 54, 69, 99
 — sulphur in the blast furnace, 98
 Reeking of ingot-moulds, 423
 Refined iron, Analyses of, 244
 — metal, 239, 244
 Refinery, 229, 239
 — cinder or slag, Analyses of, 244
 — — — Formulæ of, 243
 — Elevation of, 239
 — Melting-down, 242
 — Plan of, 240
 — Running in, 242
 — Yield of, 246
 — Yorkshire, 242
 Refining of pig-iron, 11, 228, 229, 238
 — — — — Reactions in the, 243
- Refractory materials, 14
 Regenerative gas-furnace, Siemens, 371
 Regenerators, 373
 — Surface of, 377
 Regulator for the blast furnace, 163
 Reheating furnace, 355
 — — Bicheroux, 378
 — — Boëtius, 378
 — — Siemens, 371
 Relining and repairing of converters, 488
 Reverberatory furnace for steel-melting, 429
 Reversing mills, 327, 330
 — — Engines for, 340
 — — valves for Siemens furnaces, 374
 Revolving furnaces, 287
 — — Crampton's, 288, 295
 — — Danks, 288
 — — Maudsley's, 288
 — — Menelaus', 288
 — — Pernot's, 293
 — — Ponsard's, 278, 380, 452
 — — Sellers', 288
 — — Siemens, 213, 288
 — — Spencer's, 294
 — — Tooth's, 283
 — — Walker and Warren's, 287
 Rising of steel in the moulds, 424
 Rivets, 7
 — Tests for, 401
 Roasting of ferrous silicates, 83
 — iron ores, 81
 — — — — between closed walls, 87
 — — — — in kilns, 88
 — — — — open heaps, 84
 — — pyritous ores, 86
 Rocks, Use of, in furnace construction, 14
 Rollers, Feed, 338
 Rolling, Effect of cold-, 4, 5
 — mill engines, 340
 — — — Size and speed of, 337
 — mills, 319
 — — American, 339
 — — Belgian, 336
 — — for steel, 346, 516
 — — of plates, 211, 330, 333
 — — rails, 338, 361
 — — steel, Loss in, 361
 Rolls, 319
 — for merchant iron, 327
 — Four high, 337
 — Housings or standard for, 321
 — Mill, 319, 324
 — Puddling, 319
 — Roughing, 319, 330
 Roots' blower, 194
 Rotary furnace, Siemens, 213

- Rotary squeezer, 304
 Rotation of steel castings, 514
 Rouge, 44
 Rough pottery-mine, 261
 Roughing rolls, 319, 330
 — hole, 131
 Running-in refinery, 242
 — of pig-iron, 129
 — out fire, 229, 230, 239
 Russian sheet-iron, 7
 Rusting of iron, 42
- SAGGERS, 284**
 Sampling in the basic process, 497
- Sand-bed, 129
 — Burnt, 196
 — Foundry, 196
 — Siliceous, 23
 Sandstones, 23
 Sap in blister steel bars, 411
 Saw for cutting hot iron, 346
 Scaffolding of the blast furnace, 139, 142
 Schafhäütl's powder, 271, 439
 Schiele's fans, 194
 Scotch twyers, 127
 Scouring slags, 110
 Section of Bessemer ingot, 506
 Self-fluxing iron-ores, 104, 136
 — going iron ores, 104
 Serpentine, 23
 Shear-steel, 411
 — Double, 411, 414
 — Single, 414
 Shearing machine, 348
 Shears, Crocodile, 343
 — for puddled bars, 347
 — Guillotine, 348, 351
 — Plate, 349
 Sheds for tempering clay, 418
 Sheet-iron, Russian, 7
 — Annealing of, 9
 — mill, 334, 342
 Sheets, 211
 — Annealing of, 335
 Sherman's process, 433
 Shingling, 11, 309
 — hammer or helve, 300
 — machinery, 300
 Ship-plates, Strength of, 5, 401
 Siderite, 37
 Siemens and Bessemer process, Combined, 453
 — direct process for the production of steel, 406
 — gas producers, 363
 — Gases from, 369
- Siemens-Martin process for the production of steel, 445, 449
 — melting furnace for crucible steel, 428
 — open-hearth steel melting furnace, 445
 — — — — process, 456
 — process for the direct production of malleable iron, 211, 213
 — Regenerative gas furnace, 273, 361, 371
 — reheating furnace, 371
 — Revolving puddling furnace, 288
 — Rotator, 213
 Sight-holes in producer, 365
 Silica bricks, 21
 — Analyses of, 22
 Silicates, Colour of, 12
 — Ferrous, 55
 Silico-ferromanganese, 507
 — Analyses of, 508
 — melting, 508
 Silicon, Bessemer pig-iron and, 481, 482
 — Cast-iron and, 54, 67, 72, 99
 — Effects of, in the basic process, 503
 — heat producer in Bessemer process, 503
 — Iron and, 54, 207
 — Reduction of, in the blast furnace, 54, 69, 99
 — Steel and, 394
 — Use of, in production of sound ingots, 507
 Silver, Iron and, 61
 Singles, 211
 Single shear-steel, 414
 Size of rolling mills, 337
 Skimming gates, 201
 — of crucible steel, 423
 Skulls, Bessemer, 465, 477
 Slag, 11
 — Basic Bessemer process and, 500
 — Bessemer, 483
 — Blast furnace, 12, 14, 103, 106
 — Analyses of, 107
 — Phosphorus in, 98
 — Sulphur in, 98, 109
 — Uses of, 131
 — Bricks of, 131
 — Mill-furnace, 360
 — test for the Bessemer blow, 470, 478, 485
 — wool, 132
 Slags, 12, 103
 — Formulæ of, 12, 106, 217, 243
 — from the puddling of steel, 438, 439
 — of the Catalan furnace, 218
 — Puddling furnace, 253, 266

- Slags, Refinery, 14, 243, 244
 — Scouring, 110
 — Sulphur in, 98, 109
 Slips in the blast furnace, 142
 Slit-rods, 210, 339
 Slitting mill, 210, 339
 Slurry, 466
 Smelting of pig-iron, 92
 Soaking-pits, 382
 — — Gases from, 383
 Soft-centred steel, 516
 Softness, Definition of, 8
 Solubility of pig-iron in acids, 69
 Somorrostro iron-ore, 35, 36
 Sound ingots produced by pressure, 510
 — — — — rotation, 514
 — — — — stirring, 514
 South Wales process for the conversion of pig-iron into malleable iron, 229
 Sow, 129
 Spathic iron-ore, 37
 Specific gravity of compressed steel, 512
 — — — — malleable iron, 41, 205
 — — — — pig-iron, 63
 — — — — steel, 387, 512
 Spectroscope, Application of, to the Bessemer process, 490
 Specular iron, 33
 Speed of puddling-rolls, 324
 — — rolling mills, 337
 Spenser's revolving furnace, 294
 Spiegel, Analysis of, 65
 — Cupola for melting, 470
 Spiegeleisen, 53, 74, 99
 — Analysis of, 65
 — Charges of furnace for, 178
 — Ores for production of, 38
 — Use of, in steel-making, 393, 395, 480, &c.
 Spindles for rolls, 321, 323
 Sponge, Metallic, 225, 404
 Spring temper of blister-steel, 411, 414
 Sprue gates, 201
 Squeezers, 301
 — Alligator and crocodile, 301
 — Brown's, 301, 303
 — Double, 302
 — Horizontal, 303
 — Hydraulic, 307
 — Rotary, 304
 — Winslow's, 306
 Staffordshire blast-furnace, 111, 116
 — charges for puddling-furnaces, 268
 — tap-cinder, 280
 — twyer, 127
 Stampings, 232, 269
 Stamps, 232
 Steam-hammer, 310, 518
 — — Foundations for, 314
 — — hoists, 168
 Steatite, 23
 Steel, 384
 — Action of manganese in, 388, 394, 433
 — Alloys of, 394
 — Aluminum and, 61, 396
 — Analysis of, 384
 — Annealing of, 391
 — Bessemer process for the manufacture of, 460
 — Blister, 411, 412
 — Burnt, 391
 — Carbon in, 384, 398
 — Castings in, 518
 — Cast or crucible, 415
 — Catalan process for the production of, 403
 — Cementation, 411, 412, 415
 — Chromium and, 388, 396
 — Copper and, 59, 396
 — Corrosion of, 387
 — Crude, 441
 — Decarburisation methods for the production of, 403
 — Definition of, 385
 — Double-shear, 411, 414
 — Elasticity of, 391, 397, 401
 — Ellershausen process for the production of, 444
 — Flexibility of, 400
 — Forge tests for, 399
 — Gold and, 396
 — Government tests for, 399
 — Hardening of, 388
 — Heaton crude, 440
 — Henderson process for the production of, 442
 — Homogeneous, 416
 — ingots, Unsoundness of, 506
 — in the Catalan forge, 403
 — Limit of elasticity of, 401
 — Manganese and, 388, 394, 433
 — melting crucible, 24, 419
 — — furnace, Siemens open-hearth, 445
 — — house or furnace, 416
 — — point of, 387
 — Methods for the production of, 402
 — Natural, 404
 — Nitrogen and, 384
 — Occlusion of gases by, 392
 — Oil-hardening of, 391
 — Open-hearth, 445
 — Phosphorus in, 393
 — Physics for, 432
 — Platinum and, 61, 396
 — Production of, by the decarburisation of pig iron in the finery, 433

- Steel, Production of, by the fusion of bar iron with charcoal, 430.
- pig-iron with malleable iron, 445
 - direct from the ore, 402, 406
 - Puddled, 434
 - rails, Analyses of, 401, 479
 - Rolling of, 338
 - Red-shortness of, 51, 394, 395
 - Rigidity of, 397
 - Rolling of, 346
 - Shear, 411, 414
 - Siemens-Martin, 445, 449
 - direct process for the production of, 406
 - Silicon and, 394, 507
 - Soft or mild centred, 516
 - Specific gravity of, 387
 - Structural uses of, 5, 402
 - Styrian method for the production of, 433
 - Sulphur and, 393
 - Tempering of, 388, 389
 - Tempers of, 398
 - Tenacity of, 397
 - Tensile strength of, 397
 - Tin and, 60, 396
 - Titanium and, 396
 - Transverse strength of, 400
 - Tungsten and, 388, 395
 - Uchatius method for the production of, 443
 - Wire-drawing of, 387, 397, 401
- Sterro-metal, 59
- Stopper-hole, 258
- Stopping of steel ingots, 422, 424, 450, 473
- Stourbridge clay, Analyses of, 17
- Stoves, 143
- Hot-blast, 143, 147, 150, 151, 155, 159
- Strength of bar-iron, 53, 209
- castings, 186
 - cast-iron, 71
 - iron, 208, 209
 - steel, 53, 397, 399, 400, 401
 - Units of, 1
- Stripping of ingots, 382, 472
- plate for mill rolls, 326
- Stückofen furnace, 225
- Styrian blast furnace, 130, 133
- method of producing steel, 433
- Sulphide of iron, 50
- Sulphur, Cast-iron and, 50, 71
- Elimination of, in the puddling process, 253, 267, 271
 - in slags, 28, 109, 253
 - Iron and, 50, 71, 207
 - Malleable iron and, 51, 207
 - Pig-iron and, 50
- Sulphur, Reduction of, in the blast furnace, 98, 102
- Steel and, 393
- Suspension links, 4
- Sweden, Walloon process of, 229, 235
- Swedish blast furnace, 112, 124, 135
- brands of bar-iron, 431
 - calcining kiln, 91
 - finery, 233
 - iron ores, 32
 - Lancashire hearth, 233
 - pigs, 130
- TAP-CINDER**, 56, 266, 276, 279, 280
- Formulae of, 14
 - hole of the blast furnace, 117
 - Siemens furnace, and stopping of, 448
- Tapping of the blast furnace, 129
- Teeming-holes, 417
- of steel ingots, 422
- Temperature attainable in the regenerative furnace, 376
- Effect on the ductility of iron, 3
 - strength of iron, 5
 - in the tempering of steel, 390
 - of blast for the blast furnace, 143
 - furnace, 101
 - the Bessemer flame, 486
- Temperatures, 8
- Temper of steel, 398
- Tempering of steel, 388
- Tenacity, Effect of annealing upon, 2
- hammering upon, 2, 397
 - hardening upon, 2, 388
 - wire-drawing upon, 4, 387, 397, 398
 - of malleable iron, 2, 53, 209
 - metals, 1
 - steel, 2, 397
- Tensile strength, 2, 4
- Effect of temperature upon, 5
 - for axles, &c., 402
 - ships' plates, 401
 - of iron, 208
 - steel, 397, 398, 400
- Terms, Metallurgical, 1
- Terne-plates, 60
- Terre-noire silicon steel, 509
- Test-pieces, Forms of, 2
- Length of, 3
- Testing machine, 351
- of rails, 401
 - plates, rivets, &c., 401

- Tests of the metal in the basic process, 497
 Thomas, Gilchrist process, 492
 Three-high rail mill, 342
 — — rolls, 327
 Throat of the blast furnace, 114
 Tilt-hammer, 307
 Tin, Iron and, 59, 60, 208
 — Pig-iron and, 74
 — Steel and, 60, 397
 Titanic steel, 396
 Titaniferous iron-ore, 36
 — — sands, 79
 — — — Smelting of, 224
 Titanium, Blast furnace slags and, 109
 — Iron and, 73, 208
 — Nitrocyamide of, 142
 Tools, Puddler's, 280
 Topping of steel ingots, 424
 Tops and bottoms, Method of, 233
 — Furnace, 121, 124, 125
 Toughness of metals, 8
 Transfer method of the basic process, 504
 — — — — — Analysis of the products from, 504
 Transverse strength of malleable iron, 400
 — — — steel, 400
 Trial or tap-bars of the cementation process, 409
 Trompe or blowing machine of the Catalan furnace, 219
 Tube for taking waste gases from the blast furnace, 125
 Tungsten, Iron and, 58
 — Steel and, 338, 395
 Tunnel head, 116
 Turf, Use of, in the blast furnace, 171
 Twyers, Hot-blast, 126
 — Scotch, 127
 — Staffordshire, 127
 Tymp, 117
 — -arch, 117
 — -stone, 117
 Tyres, Rolling of, 517
 — Strength of, 401
- UCHATIUS** process for the production of steel, 443
 Ultramarine, Artificial, 109
 Ulverstone iron-ore, 34
 Unit employed in Russia, France, &c., for tensile stress, 2
 Universal rolling mill, 336
 Unsoundness of steel ingots, 392, 424, 425, 506
- Use of the hot-blast, 173
 Utilisation of the waste heat of the blast furnace, 121, 123, 181
- VARIETIES** in the dimensions of the blast furnace, 111, 113
 Vein-stuff, 10
 Vertical Section of blast furnace, 116, 118, 119
 — — — cementation furnace, 407
 — — — Danks revolving puddling furnace, 238
 — — — Pernot's revolving puddling furnace, 254
 — — — puddling furnace, 254
 — — — — re-heating furnace, 372
 — — — Siemens open-hearth steel furnace, 447
 Vessel-man, 466
- WABBLERS** of rolls, 322
 Walker and Warren's revolving furnace, 287
 Walloon process of Sweden, 229, 235
 Washing process, Bell's, 246
 — — Krupp's, 246
 Waste gases of the blast furnace, 181
 — — — — — Methods for the collection of, 121, 125, 181
 Water-balance lift, 165
 Weathering of iron ores, 80
 Welding, 7, 55, 204
 — Effect of foreign bodies upon, 8
 — of steel, 387
 Westphalian hot-blast stove, 150
 Wet puddling, 249, 259, 267
 Wheelswarf, 410
 White-heat, 8
 — pig-iron, 48, 98
 — — — Production of, 98, 102
 Whitham's rabbling apparatus, 278, 287
 Whitwell's stove, 155
 Whitworth process for the fluid compression of steel, 510
 Whitworth's casting press, 511
 — definition of steel, 385
 — hydraulic forging press, 316
 Winches, 168
 Winslow's squeezer, 306
 Wipes, 308
 Wire-drawing, Effect on the strength of iron of, 4
 — — — — steel of, 387, 397, 398

Wire-drawing, Elastic limit of, 4
 — gauge, Birmingham, 211
 Wood, Use in the blast furnace of,
 171
 Wootz, 432
 Wrought-iron, 202

YELLOW iron pyrites, 52
 Yield of the basic process, 504

Yield of the blast furnace, 175, 179
 — — merchant bars, 360
 — — Siemens open-hearth steel
 furnace, 457
 Yorkshire refinery, 242

ZINC, Iron and, 59, 208
 Zinced plates, 59
 Zones of the blast furnace. 100

Illustrated, Fine-Art, and other Volumes.

- Art, The Magazine of. Yearly Volume. With 500 choice Engravings. 16s.
- After London; or, Wild England. By RICHARD JEFFERIES. 10s. 6d.
- Bismarck, Prince. By CHARLES LOWE, M.A. Two Vols., demy 8vo. With two Portraits. 24s.
- Bright, John, Life and Times of. By W. ROBERTSON. 7s. 6d.
- British Ballads. With 275 Original Illustrations. Two Vols. Cloth, 7s. 6d. each.
- British Battles on Land and Sea. By JAMES GRANT. With about 600 Illustrations. Three Vols., 4to, £1 7s.; Library Edition, £1 10s.
- British Battles, Recent. Illustrated. 4to, 9s.; Library Edition, 10s.
- Butterflies and Moths, European. By W. F. KIRBY. With 61 Coloured Plates. Demy 4to, 35s.
- Canaries and Cage-Birds, The Illustrated Book of. By W. A. BLAKSTON, W. SWAYSLAND, and A. F. WIENER. With 56 Fac-simile Coloured Plates, 35s. Half-morocco, £2 5s.
- Cassell's Family Magazine. Yearly Vol. Illustrated. 9s.
- Cathedral Churches of England and Wales. With 150 Illustrations. 21s. *Édition de luxe*, £2 2s.
- Changing Year, The. With Illustrations. 7s. 6d.
- Choice Dishes at Small Cost. By A. G. PAYNE. 3s. 6d.
- Choice Poems by H. W. Longfellow. Illustrated. 6s.
- Cities of the World: their Origin, Progress, and Present Aspect. Three Vols. Illustrated. 7s. 6d. each.
- Clinical Manuals for Practitioners and Students of Medicine. A List of Volumes forwarded post free on application to the Publishers.
- Colonies and India, Our, How we Got Them, and Why we Keep Them. By Prof. C. RANSOME. 1s.
- Columbus, Christopher, The Life and Voyages of. By WASHINGTON IRVING. Three Vols. 7s. 6d.
- Cookery, Cassell's Dictionary of. Containing about Nine Thousand Recipes, 7s. 6d.; half-roan, 9s.; Roxburgh, 10s. 6d.
- Co-operators, Working Men: What they have Done, and What they are Doing. By A. H. DYKE-ACLAND and B. JONES. 1s.
- Cookery, A Year's. By PHYLLIS BROWNE. Cloth gilt, or oiled cloth, 3s. 6d.
- Countries of the World, The. By ROBERT BROWN, M.A., Ph.D., &c. Complete in Six Vols., with about 750 Illustrations. 4to, 7s. 6d. each.
- Cromwell, Oliver: The Man and his Mission. By J. ALLANSON PICTON, M.P. Cloth, 7s. 6d.; morocco, cloth sides, 9s.
- Cyclopædia, Cassell's Concise. With 12,000 subjects, brought down to the latest date. With about 600 Illustrations, 15s.; Roxburgh, 18s.
- Dairy Farming. By Prof. J. P. SHELDON. With 25 Fac-simile Coloured Plates, and numerous Wood Engravings. Cloth, 31s. 6d.; half-morocco, 42s.
- Decisive Events in History. By THOMAS ARCHER. With Sixteen Illustrations. Boards, 3s. 6d.; cloth, 5s.

Selections from Cassell & Company's Publications.

- Decorative Design, Principles of. By CHRISTOPHER DRESSER, Ph.D. Illustrated. 5s.
- Deserted Village Series, The. Consisting of *Éditions de luxe* of the most favourite poems of Standard Authors. Illustrated. 2s. 6d. each.
- | | | |
|--------------------------------------|--|--|
| GOLDSMITH'S DESERTED VILLAGE. | | WORDSWORTH'S ODE ON IMMORTALITY, AND LINES ON TINTERN ABBEY. |
| MILTON'S L'ALLEGRO AND IL PENSEROSO. | | |
- Dickens, Character Sketches from. SECOND and THIRD SERIES. With Six Original Drawings in each, by FREDERICK BARNARD. In Portfolio, 21s. each.
- Diary of Two Parliaments. The Disraeli Parliament. By H. W. LUCY. 12s.
- Dog, The By IDSTONE. Illustrated. 2s. 6d.
- Dog, Illustrated Book of the. By VERO SHAW, B.A. With 28 Coloured Plates. Cloth bevelled, 35s.; half-morocco, 45s.
- Domestic Dictionary, The. An Encyclopædia for the Household. Cloth, 7s. 6d.
- Doré's Adventures of Munchausen. Illustrated by GUSTAVE DORÉ. 5s.
- Doré's Dante's Inferno. Illustrated by GUSTAVE DORÉ. *Popular Edition*, 21s.
- Doré's Don Quixote. With about 400 Illustrations by DORÉ. 15s.
- Doré's Fairy Tales Told Again. With 24 Full-page Engravings by GUSTAVE DORÉ. 5s.
- Doré Gallery, The. *Popular Edition* With 250 Illustrations by GUSTAVE DORÉ. 4to, 42s.
- Doré's Milton's Paradise Lost. With Full-page Drawings by GUSTAVE DORÉ. 4to, 21s.
- Edinburgh, Old and New, Cassell's. Three Vols. With 600 Illustrations. 9s. each.
- Educational Year-Book, The. 6s.
- Egypt: Descriptive, Historical, and Picturesque. By Prof. G. ÉBERS. Translated by CLARA BELL, with Notes by SAMUEL BIRCH, LL.D., &c. Two Vols. With 800 Original Engravings. Vol. I., £2 5s.; Vol. II., £2 12s. 6d. Complete in box, £4 17s. 6d.
- Electrician's Pocket-Book, The. By GORDON WIGAN, M.A. 5s.
- Encyclopædic Dictionary, The. A New and Original Work of Reference to all the Words in the English Language. Nine Divisional Vols. now ready, 10s. 6d. each; or the Double Divisional Vols., half-morocco, 21s. each.
- Energy in Nature. By WM. LANT CARPENTER, B.A., B.Sc. 80 Illustrations. 3s. 6d.
- England, Cassell's Illustrated History of. With 2,000 Illustrations. Ten Vols., 4to, 9s. each.
- English History, The Dictionary of. Cloth, 21s.; Roxburgh, 25s.
- English Literature, Library of. By Prof. HENRY MORLEY.
- | |
|---|
| VOL. I.—SHORTER ENGLISH POEMS, 12s. 6d. |
| VOL. II.—ILLUSTRATIONS OF ENGLISH RELIGION, 11s. 6d. |
| VOL. III.—ENGLISH PLAYS, 11s. 6d. |
| VOL. IV.—SHORTER WORKS IN ENGLISH PROSE, 11s. 6d. |
| VOL. V.—SKETCHES OF LONGER WORKS IN ENGLISH VERSE AND PROSE, 11s. 6d. |
- Five Volumes handsomely bound in half-morocco, £5 5s. Volumes I., II., and III. of the *Popular Edition* are now ready, price 7s. 6d. each.
- English Literature, The Story of. By ANNA BUCKLAND. 5s.

Selections from Cassell & Company's Publications.

- English Literature, Dictionary of. By W. DAVENPORT ADAMS.
Cheap Edition, 7s. 6d.; Roxburgh, 10s. 6d.
- English Poetesses. By ERIC S. ROBERTSON, M.A. 5s.
- Æsop's Fables. With about 150 Illustrations by E. GRISET. Cloth,
7s. 6d.; gilt edges, 10s. 6d.
- Etiquette of Good Society. 1s.; cloth, 1s. 6d.
- Family Physician, The. By Eminent PHYSICIANS and SURGEONS.
Cloth, 21s.; half-morocco, 25s.
- Far, Far West, Life and Labour in the. By W. HENRY BARNEBY.
With Map of Route. Cloth, 16s.
- Fenn, G. Manville, Works by. *Popular Editions*. Cloth boards,
2s. each.
- | | |
|---|---|
| <p>SWEET MACE.</p> <p>DUTCH, THE DIVER; OR, A MAN'S
MISTAKE.</p> <p>MY PATIENTS. Being the Notes
of a Navy Surgeon.</p> <p>Ferns, European. By JAMES BRITTEN, F.L.S. With 30 Fac-simile
Coloured Plates by D. BLAIR, F.L.S. 21s.</p> <p>Festival Tales. By J. F. WALLER. 3s. 6d.</p> <p>Field Naturalist's Handbook, The. By the Rev. J. G. WOOD
and THEODORE WOOD. 5s.</p> <p>Figuiet's Popular Scientific Works. With Several Hundred Illustrations
in each. 3s. 6d. each; half-calf, 6s. each.</p> <p>THE HUMAN RACE.</p> <p>WORLD BEFORE THE DELUGE.</p> <p>REPTILES AND BIRDS.</p> | <p>THE VICAR'S PEOPLE.</p> <p>COBWEB'S FATHER, AND OTHER
STORIES.</p> <p>THE PARSON O' DUMFORD.</p> <p>POVERTY CORNER.</p> <p>THE OCEAN WORLD.</p> <p>THE VEGETABLE WORLD.</p> <p>THE INSECT WORLD.</p> |
|---|---|
- MAMMALIA.
- Fine-Art Library, The. Edited by JOHN SPARKES, Principal of the
South Kensington Art Schools. Each Book contains about 100
Illustrations. 5s. each.
- | | |
|--|---|
| <p>TAPESTRY. By Eugene Müntz.
Translated by Miss L. J. Davis.</p> <p>ENGRAVING. By Le Vicomte Henri
Delaborde. Translated by R.
A. M. Stevenson.</p> <p>THE ENGLISH SCHOOL OF PAINT-
ING. By E. Chesneau. Translated
by L. N. Etherington. With an
Introduction by Prof. Ruskin.</p> <p>THE FLEMISH SCHOOL OF PAINTING.
By A. J. Wauters. Translated
by Mrs. Henry Rossel.</p> | <p>GREEK ARCHÆOLOGY. By Maxime
Collignon. Translated by Dr.
J. H. Wright, Associate Pro-
fessor of Greek in Dartmouth
Coll., U.S.A.</p> <p>ARTISTIC ANATOMY. By Prof.
Duval. Translated by F. E.
Fenton.</p> <p>THE DUTCH SCHOOL OF PAINTING.
By Henry Havard. Translated
by G. Powell.</p> |
|--|---|
- Fishes of the World, The. Illustrated. 4to. 9s.
- Five Pound Note, The, and other Stories. By G. S. JEALOUS. 1s.
- Forging of the Anchor, The. A Poem. By Sir SAMUEL FERGUSON,
LL.D. With 20 Original Illustrations. Gilt edges, 5s.
- Fossil Reptiles, A History of British. By Sir RICHARD OWEN,
K.C.B., F.R.S., &c. With 268 Plates. In Four Vols., £12 12s.
- Four Years of Irish History (1845-49). By Sir GAVAN DUFFY,
K.C.M.G. 21s.
- Franco-German War, Cassell's History of the. Two Vols. With
500 Illustrations. 9s. each.

Selections from Cassell & Company's Publications.

- Garden Flowers, Familiar.** FIRST, SECOND, THIRD, and FOURTH SERIES. By SHIRLEY HIBBERD. With Original Paintings by F. E. HULME, F.L.S. With 40 Full-page Coloured Plates in each. Cloth gilt, in cardboard box (or in morocco, cloth sides), 12s. 6d. each.
- Gardening, Cassell's Popular.** Illustrated. Vols. I., II., and III., 5s. each.
- Gladstone, Life of W. E.** By BARNETT SMITH. With Portrait, 3s. 6d. *Jubilee Edition*, 1s.
- Gleanings from Popular Authors.** Two Vols. With Original Illustrations. 4to, 9s. each. Two Vols. in One, 15s.
- Great Industries of Great Britain.** Three Vols. With about 400 Illustrations. 4to., cloth, 7s. 6d. each.
- Great Painters of Christendom, The, from Cimabue to Wilkie.** By JOHN FORBES-ROBERTSON. Illustrated throughout. 12s. 6d.
- Great Western Railway, The Official Illustrated Guide to the.** With Illustrations, 1s. ; cloth, 2s.
- Gulliver's Travels.** With 88 Engravings by MORTEN. *Cheap Edition*, 5s.
- Guide to Employment in the Civil Service.** 3s. 6d.
- Guide to Female Employment in Government Offices.** 1s.
- Gun and its Development, The.** By W. W. GREENER. With 500 Illustrations. 10s. 6d.
- Health, The Book of.** By Eminent Physicians and Surgeons. Cloth, 21s. Half-morocco, 25s.
- Heavens, The Story of the.** By ROBERT STAWELL BALL, LL.D., F.R.S., F.R.A.S., Royal Astronomer of Ireland. With 16 *Separate Plates* printed by Chromo-Lithography, and 90 Wood Engravings. Demy 8vo, 544 pages, cloth. 31s. 6d.
- Heroes of Britain in Peace and War.** In Two Vols., with 300 Original Illustrations. Cloth, 5s. each.
- Horse, The Book of the.** By SAMUEL SIDNEY. With 25 *fac-simile* Coloured Plates. Demy 4to, 31s. 6d. ; half-morocco, £2 2s.
- Horses, The Simple Ailments of.** By W. F. Illustrated. 5s.
- Household Guide, Cassell's.** With Illustrations and Coloured Plates. Two Double Vols., half-calf, 31s. 6d. ; Library Edition, Two Vols., 24s.
- How to Get on.** With 1,000 Precepts for Practice. 3s. 6d.
- How Women may Earn a Living.** By MERCY GROGAN. 1s.
- India, The Coming Struggle for.** By Prof. ARMINIUS VAMBÉRY. With Map in Colours. 5s.
- India, Cassell's History of.** By JAMES GRANT. With about 400 Illustrations. Two Vols., 9s. each.
- India: the Land and the People.** By Sir JAMES CAIRD, K.C.B. 10s. 6d.
- In-door Amusements, Card Games, and Fireside Fun, Cassell's Book of.** Illustrated. 3s. 6d.
- International Portrait Gallery, The.** Two Vols., each containing 20 Portraits in Colours. 12s. 6d. each.
- Invisible Life, Vignettes from.** By JOHN BADCOCK, F.R.M.S. Illustrated. 3s. 6d.
- Italy.** By J. W. PROBYN. 7s. 6d.
- Kennel Guide, Practical.** By Dr. GORDON STABLES. Illustrated. 2s. 6d.
- Khiva, A Ride to.** By the late Col. FRED BURNABY. 1s. 6d.
- Ladies' Physician, The.** By a London Physician. 6s.

- Land Question, The. By Prof. J. ELLIOT, M.R.A.C. 10s. 6d.
- Landscape Painting in Oils, A Course of Lessons in. By A. F. GRACE. With Nine Reproductions in Colour. *Cheap Edition*, 25s.
- Law, About Going to. By A. J. WILLIAMS. 2s. 6d.
- London & North-Western Railway Official Illustrated Guide. 1s.; cloth, 2s.
- London, Greater. By EDWARD WALFORD. Two Vols. With about 400 Illustrations. 9s. each.
- London, Old and New. Six Vols., each containing about 200 Illustrations and Maps. Cloth, 9s. each.
- London's Roll of Fame. With Portraits and Illustrations. 12s. 6d.
- Longfellow's Poetical Works. Illustrated. £3 3s.
- Love's Extremes, At. By MAURICE THOMPSON. 5s.
- Mechanics, The Practical Dictionary of. Containing 15,000 Drawings. Four Vols. 21s. each.
- Medicine, Manuals for Students of. *A List forwarded post free on application.*
- Microscope, The; and some of the Wonders it Reveals. 1s.
- Midland Railway, Official Illustrated Guide to the. 1s.; cloth, 2s.
- Modern Artists, Some. With highly-finished Engravings. 12s. 6d.
- Modern Europe, A History of. By C. A. FYFFE, M.A. Vol. I. from 1792 to 1814. 12s.
- National Portrait Gallery, The. Each Volume containing 20 Portraits, printed in Chromo-Lithography. Four Vols., 12s. 6d. each; or in Two Double Vols., 21s. each.
- Natural History, Cassell's Concise. By E. PERCEVAL WRIGHT, M.A., M.D., F.L.S. With several Hundred Illustrations. 7s. 6d.
- Natural History, Cassell's New. Edited by Prof. P. MARTIN DUNCAN, M.B., F.R.S., F.G.S. With Contributions by Eminent Scientific Writers. Complete in Six Vols. With about 2,000 high-class Illustrations. Extra crown 4to, cloth, 9s. each.
- Natural History, Cassell's Popular. With about 2,000 Engravings and Coloured Plates. Complete in Four Vols. Cloth gilt, 42s.
- Nature, Short Studies from. Illustrated. 5s.
- Novels, Cassell's Shilling. Consisting of New and Original Works of Romance and Adventure by Leading Writers. Price 1s. each.
- AS IT WAS WRITTEN. By S. | THE CRIMSON STAIN. By A. Luska. | Bradshaw.
- MORGAN'S HORROR. By G. Manville Fenn.
- Nursing for the Home and for the Hospital, A Handbook of. By CATHERINE J. WOOD. *Cheap Edition*. 1s. 6d.; cloth, 2s.
- On the Equator. By H. DE W. Illustrated with Photos. 3s. 6d.
- Our Homes, and How to Make them Healthy. By Eminent Authorities. Illustrated. 15s.; half-morocco, 21s.
- Our Own Country. Six Vols. With 1,200 Illustrations. Cloth, 7s. 6d. each.
- Outdoor Sports and Indoor Amusements. With nearly 1,000 Illustrations. 9s.
- Paris, Cassell's Illustrated Guide to. 1s.; cloth, 2s.
- Parliaments, A Diary of Two. By H. W. LUCY. The Disraeli Parliament, 1874—1880. 12s.
- Paxton's Flower Garden. By Sir JOSEPH PAXTON and Prof. LINDLEY. Revised by THOMAS BAINES, F.R.H.S. Three Vols. With 100 Coloured Plates. £1 1s. each.

Selections from Cassell & Company's Publications.

Peoples of the World, The. Vols. I. to V. By Dr. ROBERT BROWN. With Illustrations. 7s. 6d. each.

Perak and the Malays. By Major FRED McNAIR. Illustrated. 10s. 6d.

Photography for Amateurs. By T. C. HEPWORTH. Illustrated. 1s.; or cloth, 1s. 6d.

Phrase and Fable, Dictionary of. By the Rev. Dr. BREWER. *Cheap Edition, Enlarged*, cloth, 3s. 6d.; or with leather back, 4s. 6d.

Pictures from English Literature. With Full-page Illustrations. 5s.

Pictures of Bird Life in Pen and Pencil. Illustrated. 21s.

Picturesque America. Complete in Four Vols., with 48 Exquisite Steel Plates and about 800 Original Wood Engravings. £2 2s. each.

Picturesque Canada. With about 600 Original Illustrations. Two Vols. £3 3s. each.

Picturesque Europe. Complete in Five Vols. Each containing 13 Exquisite Steel Plates, from Original Drawings, and nearly 200 Original Illustrations. £10 10s.; half-morocco, £15 15s.; morocco gilt, £26 5s. The POPULAR EDITION is published in Five Vols., 18s. each., of which Four Vols. are now ready.

Pigeon Keeper, The Practical. By LEWIS WRIGHT. Illustrated. 3s. 6d.

Pigeons, The Book of. By ROBERT FULTON. Edited and Arranged by LEWIS WRIGHT. With 50 Coloured Plates and numerous Wood Engravings. 31s. 6d.; half-morocco, £2 2s.

Poems and Pictures. With numerous Illustrations. 5s.

Poets, Cassell's Miniature Library of the :—

BURNS. Two Vols. 2s. 6d.

BYRON. Two Vols. 2s. 6d.

HOOD. Two Vols. 2s. 6d.

LONGFELLOW. Two Vols. 2s. 6d.

MILTON. Two Vols. 2s. 6d.

SCOTT. Two Vols. 2s. 6d. [2s. 6d.

SHERIDAN and GOLDSMITH. 2 Vols.

WORDSWORTH. Two Vols. 2s. 6d.

SHAKESPEARE. Twelve Vols., in box, 15s.

Police Code, and Manual of the Criminal Law. By C. E. HOWARD VINCENT. 2s.

Popular Library, Cassell's. A Series of New and Original Works. Cloth, 1s. each.

THE RUSSIAN EMPIRE.

THE RELIGIOUS REVOLUTION
IN THE 16TH CENTURY.

ENGLISH JOURNALISM.

THE WIT AND WISDOM OF
THE BENCH AND BAR.

THE ENGLAND OF SHAKESPEARE.

THE HUGUENOTS.

OUR COLONIAL EMPIRE.

JOHN WESLEY.

THE YOUNG MAN IN THE
BATTLE OF LIFE.

THE STORY OF THE ENGLISH
JACOBS.

DOMESTIC FOLK LORE.

THE REV. ROWLAND HILL:
Preacher and Wit.

BOSWELL AND JOHNSON:
their Companions and Con-
temporaries.

THE SCOTTISH COVE-
NANTERS.

HISTORY OF THE FREE-
TRADE MOVEMENT IN
ENGLAND.

Poultry Keeper, The Practical. By L. WRIGHT. With Coloured Plates and Illustrations. 3s. 6d.

Poultry, The Illustrated Book of. By L. WRIGHT. With Fifty Exquisite Coloured Plates, and numerous Wood Engravings. Cloth, 31s. 6d.; half-morocco, £2 2s.

Poultry, The Book of. By LEWIS WRIGHT. *Popular Edition*. With Illustrations on Wood, 10s. 6d.

- Quiver Yearly Volume, The.** With about 300 Original Contributions by Eminent Divines and Popular Authors, and upwards of 250 high-class Illustrations. 7s. 6d.
- Rabbit-Keeper, The Practical.** By CUNICULUS. Illustrated. 3s. 6d.
- Rays from the Realms of Nature.** By the Rev. J. NEIL, M.A. Illustrated. 2s. 6d.
- Red Library of English and American Classics, The.** Stiff covers, 1s. each; cloth, 2s. each; or half-calf, marbled edges, 5s.
- | | | |
|---|--|---|
| WASHINGTON IRVING'S
SKETCH BOOK.
THE LAST DAYS OF PALMYRA.
TALES OF THE BORDERS.
PRIDE AND PREJUDICE.
THE LAST OF THE MOHICANS.
THE HEART OF MIDLOTHIAN.
THE LAST DAYS OF POMPEII. | | AMERICAN HUMOUR.
SKETCHES BY BOZ.
MACAULAY'S LAYS, AND
SELECTED ESSAYS.
HARRY LORREQUER.
THE OLD CURIOSITY SHOP.
RIENZI.
THE TALISMAN. |
|---|--|---|
- Romeo and Juliet.** *Édition de Luxe.* Illustrated with Twelve Superb Photographures from Original Drawings by F. DICKSEE, A.R.A. £5 5s.
- Royal River, The: The Thames from Source to Sea.** With Descriptive Text and a Series of beautiful Engravings. £2 2s.
- Russia.** By D. MACKENZIE WALLACE, M.A. 5s.
- Russo-Turkish War, Cassell's History of.** With about 500 Illustrations. Two Vols., 9s. each.
- Sandwith, Humphry.** A Memoir by his Nephew, THOMAS HUMPHRY WARD. 7s. 6d.
- Saturday Journal, Cassell's.** Yearly Volume. 6s.
- Science for All.** Edited by Dr. ROBERT BROWN, M.A., F.L.S., &c. With 1,500 Illustrations. Five Vols. 9s. each.
- Sea, The: Its Stirring Story of Adventure, Peril, and Heroism.** By F. WHYMPER. With 400 Illustrations. Four Vols., 7s. 6d. each.
- Shakspeare, The Leopard.** With 400 Illustrations. Cloth, 6s.
- Shakspeare, The Royal.** With Steel Plates and Wood Engravings. Three Vols. 15s. each.
- Shakespeare, Cassell's Quarto Edition.** Edited by CHARLES and MARY COWDEN CLARKE, and containing about 600 Illustrations by H. C. SELOUS. Complete in Three Vols., cloth gilt, £3 3s.
- Sketching from Nature in Water Colours.** By AARON PENLEY. With Illustrations in Chromo-Lithography. 15s.
- Smith, The Adventures and Discourses of Captain John.** By JOHN ASHTON. Illustrated. 5s.
- Sports and Pastimes, Cassell's Book of.** With more than 800 Illustrations and Coloured Frontispiece. 768 pages. 7s. 6d.
- Steam Engine, The Theory and Action of the: for Practical Men.** By W. H. NORTHCOTT, C.E. 3s. 6d.
- Stock Exchange Year-Book, The.** By THOMAS SKINNER. 10s. 6d.
- Stones of London, The.** By E. F. FLOWER. 6d.
- "Stories from Cassell's."** 6d. each; cloth lettered, 9d. each.
- | | | |
|--|--|--|
| MY AUNT'S MATCH-MAKING.
TOLD BY HER SISTER.
THE SILVER LOCK. | | "RUNNING PILOT."
THE MORTGAGE MONEY.
GOURLAY BROTHERS. |
|--|--|--|
- A GREAT MISTAKE.
- ** The above are also issued, Three Volumes in One, cloth, price 2s. each.**
- Sunlight and Shade.** With numerous Exquisite Engravings. 7s. 6d.
- Telegraph Guide, The.** Illustrated. 1s.
- Trajan.** An American Novel. By H. F. KEENAN. 7s. 6d.

Selections from Cassell & Company's Publications.

- Transformations of Insects, The. By Prof. P. MARTIN DUNCAN, M.B., F.R.S. With 240 Illustrations. 6s.
- Treatment, The Year-Book of. A Critical Review for Practitioners of Medicine and Surgery. 5s.
- United States, Cassell's History of the. By EDMUND OLLIER. With 600 Illustrations. Three Vols. 9s. each.
- United States, Constitutional History and Political Development of the. By SIMON STERNE, of the New York Bar. 5s.
- Universal History, Cassell's Illustrated. Four Vols. 9s. each
- Vicar of Wakefield and other Works by OLIVER GOLDSMITH. Illustrated. 3s. 6d.
- Wealth Creation. By A. MONGREDIEN. 5s.
- Westall, W., Novels by. *Popular Editions.* Cloth, 2s. each.
RALPH NORBRECK'S TRUST.
THE OLD FACTORY. RED RYVINGTON.
- What Girls Can Do. By PHYLLIS BROWNE. 2s. 6d.
- Wild Animals and Birds: their Haunts and Habits. By Dr. ANDREW WILSON. Illustrated. 7s. 6d.
- Wild Birds, Familiar. First and Second Series. By W. SWAYSLAND. With 40 Coloured Plates in each. 12s. 6d. each.
- Wild Flowers, Familiar. By F. E. HULME, F.L.S., F.S.A. Five Series. With 40 Coloured Plates in each. 12s. 6d. each.
- Winter in India, A. By the Rt. Hon. W. E. BAXTER, M.P. 5s.
- Wise Woman, The. By GEORGE MACDONALD. 2s. 6d.
- Wood Magic: A Fable. By RICHARD JEFFERIES. 6s.
- World of the Sea. Translated from the French of MOQUIN TANDON, by the Very Rev. H. MARTYN HART, M.A. Illustrated. Cloth. 6s.
- World of Wit and Humour, The. With 400 Illustrations. Cloth, 7s. 6d.; cloth gilt, gilt edges, 10s. 6d.
- World of Wonders. Two Vols. With 400 Illustrations. 7s. 6d. each.
-

MAGAZINES.

- The Quiver, for Sunday Reading.* Monthly, 6d.
- Cassell's Family Magazine.* Monthly, 7d.
- "Little Folks" Magazine.* Monthly, 6d.
- The Magazine of Art.* Monthly, 1s.
- Cassell's Saturday Journal.* Weekly, 1d.; Monthly, 6d.
- * * * *Full particulars of CASSELL & COMPANY'S Monthly Serial Publications, numbering upwards of 50 different Works, will be found in CASSELL & COMPANY'S COMPLETE CATALOGUE, sent post free on application.*
-

Catalogues of CASSELL & COMPANY'S PUBLICATIONS, which may be had at all Booksellers', or will be sent post free on application to the publishers:—

CASSELL'S COMPLETE CATALOGUE, containing particulars of One Thousand Volumes.

CASSELL'S CLASSIFIED CATALOGUE, in which their Works are arranged according to price, from *Sixpence to Twenty-five Guineas.*

CASSELL'S EDUCATIONAL CATALOGUE, containing particulars of CASSELL & COMPANY'S Educational Works and Students' Manuals

CASSELL & COMPANY, LIMITED, Ludgate Hill, London.

Bibles and Religious Works.

- Bible, The Crown Illustrated. With about 1,000 Original Illustrations. With References, &c. 1,248 pages, crown 4to, cloth, 7s. 6d.
- Bible, Cassell's Illustrated Family. With 900 Illustrations. Leather, gilt edges, £2 10s.
- Bible Dictionary, Cassell's. With nearly 600 Illustrations. 7s. 6d.
- Bible Educator, The. Edited by the Very Rev. Dean PLUMPTRE, D.D., Wells. With Illustrations, Maps, &c. Four Vols., cloth, 6s. each.
- Bunyan's Pilgrim's Progress (Cassell's Illustrated). Demy 4to. Illustrated throughout. 7s. 6d.
- Bunyan's Pilgrim's Progress. With Illustrations. Cloth, 3s. 6d.
- Bunyan's Holy War. With 100 Illustrations. Cloth, 7s. 6d.
- Child's Life of Christ, The. Complete in One Handsome Volume, with about 200 Original Illustrations. Demy 4to, gilt edges, 21s.
- Child's Bible, The. With 200 Illustrations. Demy 4to, 830 pp. 143rd Thousand. Cheap Edition, 7s. 6d.
- Church at Home, The. A Series of Short Sermons. By the Rt. Rev. ROWLEY HILL, D.D., Bishop of Sodor and Man. 5s.
- Day-Dawn in Dark Places; or Wanderings and Work in Bechwanaland, South Africa. By the Rev. JOHN MACKENZIE. Illustrated throughout. Cloth, 3s. 6d.
- Difficulties of Belief, Some. By the Rev. T. TEIGNMOUTH SHORE, M.A. *New and Cheap Edition.* 2s. 6d.
- Doré Bible. With 230 Illustrations by GUSTAVE DORÉ. Cloth, £2 10s.; Persian morocco, £3 10s.
- Early Days of Christianity, The. By the Ven. Archdeacon FARRAR, D.D., F.R.S.
 LIBRARY EDITION. Two Vols., 24s.; morocco, £2 2s.
 POPULAR EDITION. Complete in One Volume, cloth, 6s.; cloth, gilt edges, 7s. 6d.; Persian morocco, 10s. 6d.; tree-calf, 15s.
- Family Prayer-Book, The. Edited by Rev. Canon GARBETT, M.A., and Rev. S. MARTIN. Extra crown 4to, cloth, 5s.; morocco, 18s.
- Geikie, Cunningham, D.D., Works by:—
 HOURS WITH THE BIBLE. Six Vols., 6s. each.
 ENTERING ON LIFE. 3s. 6d.
 THE PRECIOUS PROMISES. 2s. 6d.
 THE ENGLISH REFORMATION. 5s.
 OLD TESTAMENT CHARACTERS. 6s.
 THE LIFE AND WORDS OF CHRIST. Two Vols., cloth, 30s. *Students' Edition.* Two Vols., 16s.
- Glories of the Man of Sorrows, The. Sermons preached at St. James's, Piccadilly. By the Rev. H. G. BONAVIA HUNT. 2s. 6d.
- Gospel of Grace, The. By A. LINDESIE. Cloth, 3s. 6d.
- "Heart Chords." A Series of Works by Eminent Divines. Bound in cloth, red edges, One Shilling each.
- | | |
|--------------------|-----------------------------|
| MY FATHER. | MY SOUL. |
| * MY BIBLE. | MY GROWTH IN DIVINE LIFE. |
| MY WORK FOR GOD. | MY HEREAFTER. |
| MY OBJECT IN LIFE. | MY WALK WITH GOD. |
| MY ASPIRATIONS. | MY AIDS TO THE DIVINE LIFE. |
| MY EMOTIONAL LIFE. | MY SOURCES OF STRENGTH. |
| MY BODY. | |

- Life of Christ, The.** By the Ven. Archdeacon FARRAR, D.D., F.R.S., Chaplain-in-Ordinary to the Queen.
ILLUSTRATED EDITION, with about 300 Original Illustrations. Extra crown 4to, cloth, gilt edges, 21s. ; morocco antique, 42s.
LIBRARY EDITION. Two Vols. Cloth, 24s. ; morocco, 42s.
BIJOU EDITION. Five Volumes, in box, 10s. 6d. the set.
POPULAR EDITION, in One Vol. 8vo, cloth, 6s. ; cloth, gilt edges, 7s. 6d. ; Persian morocco, gilt edges, 10s. 6d. ; tree-calf, 15s.
- Marriage Ring, The.** By WILLIAM LANDELS, D.D. Bound in white leatherette, gilt edges, in box, 6s. ; morocco, 8s. 6d.
- Martyrs, Foxe's Book of.** With about 200 Illustrations. Imperial 8vo, 732 pages, cloth, 12s. ; cloth gilt, gilt edges, 15s.
- Moses and Geology ; or, The Harmony of the Bible with Science.** By SAMUEL KINNS, Ph.D., F.R.A.S. Illustrated. *Cheap Edition*, 6s.
- Music of the Bible, The.** By J. STAINER, M.A., Mus. Doc. 2s. 6d.
- Near and the Heavenly Horizons, The.** By the Countess DE GASPARIN. 1s. ; cloth, 2s.
- New Testament Commentary for English Readers, The.** Edited by the Rt. Rev. C. J. ELLICOTT, D.D., Lord Bishop of Gloucester and Bristol. In Three Volumes, 21s. each.
Vol. I.—The Four Gospels.
Vol. II.—The Acts, Romans, Corinthians, Galatians.
Vol. III.—The remaining Books of the New Testament.
- Old Testament Commentary for English Readers, The.** Edited by the Right Rev. C. J. ELLICOTT, D.D., Lord Bishop of Gloucester and Bristol. Complete in 5 Vols., 21s. each.
Vol. I.—Genesis to Numbers. | Vol. III.—Kings I. to Esther.
Vol. II.—Deuteronomy to Samuel II. | Vol. IV.—Job to Isaiah.
| Vol. V.—Jeremiah to Malachi.
- Patriarchs, The.** By the late Rev. W. HANNA, D.D., and the Ven. Archdeacon NORRIS, B.D. 2s. 6d.
- Protestantism, The History of.** By the Rev. J. A. WYLIE, LL.D. Containing upwards of 600 Original Illustrations. Three Vols., 27s.
- Quiver Yearly Volume, The.** 250 high-class Illustrations. 7s. 6d.
- Revised Version—Commentary on the Revised Version of the New Testament.** By the Rev. W. G. HUMPHRY, B.D. 7s. 6d.
- Sacred Poems, The Book of.** Edited by the Rev. Canon BAYNES, M.A. With Illustrations. Cloth, gilt edges, 5s.
- St. George for England ; and other Sermons preached to Children.** By the Rev. T. TEIGNMOUTH SHORE, M.A. 5s.
- St. Paul, The Life and Work of.** By the Ven. Archdeacon FARRAR, D.D., F.R.S., Chaplain in Ordinary to the Queen.
LIBRARY EDITION. Two Vols., cloth, 24s. ; morocco, 42s.
ILLUSTRATED EDITION, complete in One Volume, with about 300 Illustrations, £1 1s. ; morocco, £2 2s.
POPULAR EDITION. One Volume, 8vo, cloth, 6s. ; cloth, gilt edges, 7s. 6d. ; Persian morocco, 10s. 6d. ; tree-calf, 15s.
- Secular Life, The Gospel of the.** Sermons preached at Oxford. By the Hon. W. H. FREMANTLE, Canon of Canterbury. 5s.
- Sermons Preached at Westminster Abbey.** By ALFRED BARRY, D.D., D.C.L., Primate of Australia. 5s.
- Shall We Know One Another ?** By the Rt. Rev. J. C. RYLE, D.D., Bishop of Liverpool. *New and Enlarged Edition.* Cloth limp, 1s.
- Simon Peter : His Life, Times, and Friends.** By E. HODDER. 5s.
- Voice of Time, The.** By JOHN STROUD. Cloth gilt, 1s.

Educational Works and Students' Manuals.

- Algebra, The Elements of. By Prof. WALLACE, M.A., IS.
- Arithmetics, The Modern School. By GEORGE RICKS, B.Sc. Lond. With Test Cards. (*List on application.*)
- Book-Keeping:—
Book-Keeping for Schools. By Theodore Jones, 2s. ; cloth, 3s.
Book-Keeping for the Million. By T. Jones, 2s. ; cloth, 3s.
Books for Jones's System. Ruled Sets of, 2s.
- Commentary, The New Testament. Edited by the Lord Bishop of GLOUCESTER and BRISTOL. Handy Volume Edition.
St. Matthew, 3s. 6d. St. Mark, 3s. St. Luke, 3s. 6d. St. John, 3s. 6d. The Acts of the Apostles, 3s. 6d. Romans, 2s. 6d. Corinthians I. and II., 3s. Galatians, Ephesians, and Philippians, 3s. Colossians, Thessalonians, and Timothy, 3s. Titus, Philemon, Hebrews, and James, 3s. Peter, Jude, and John, 3s. The Revelation, 3s. An Introduction to the New Testament, 3s. 6d.
- Commentary, Old Testament. Edited by Bishop ELLICOTT. Handy Volume Edition. In Vols. suitable for School and general use.
Genesis, 3s. 6d. Exodus, 3s. Leviticus, 3s. Numbers, 2s. 6d. Deuteronomy, 2s. 6d.
- Copy-Books, Cassell's Graduated. *Eighteen Books.* 2d. each.
- Copy-Books, The Modern School. In Twelve Books, of 24 pages each, price 2d. each.
- Drawing Books for Young Artists. 4 Books. 6d. each.
- Drawing Books, Superior. 4 Books. Printed in Fac-simile by Lithography, price 5s. each.
- Drawing Copies, Cassell's Modern School Freehand. First Grade, 1s. ; Second Grade, 2s.
- Energy and Motion: A Text-Book of Elementary Mechanics. By WILLIAM PAICE, M.A. Illustrated. 1s. 6d.
- English Literature, A First Sketch of, from the Earliest Period to the Present Time. By Prof. HENRY MORLEY. 7s. 6d.
- Euclid, Cassell's. Edited by Prof. WALLACE, A.M. 1s.
- Euclid, The First Four Books of. In paper, 6d. ; cloth, 9d.
- French, Cassell's Lessons in. *New and Revised Edition.* Parts I. and II., each 2s. 6d. ; complete, 4s. 6d. Key, 1s. 6d.
- French-English and English-French Dictionary. *Entirely New and Enlarged Edition.* 1,150 pages, 8vo, cloth, 3s. 6d.
- Galbraith and Haughton's Scientific Manuals. By the Rev. Prof. GALBRAITH, M.A., and the Rev. Prof. HAUGHTON, M.D., D.C.L.
Arithmetic, 3s. 6d.—Plane Trigonometry, 2s. 6d.—Euclid, Books I., II., III., 2s. 6d.—Books IV., V., VI. 2s. 6d.—Mathematical Tables, 3s. 6d.—Mechanics, 3s. 6d.—Optics, 2s. 6d.—Hydrostatics, 3s. 6d.—Astronomy, 5s.—Steam Engine, 3s. 6d.—Algebra, Part I., cloth, 2s. 6d. ; Complete, 7s. 6d.—Tides and Tidal Currents, with Tidal Cards, 3s.
- German-English and English-German Dictionary. 3s. 6d.
- German Reading, First Lessons in. By A. JAGST. Illustrated. 1s.
- Handbook of New Code of Regulations. By JOHN F. MOSS. 1s.
- Historical Course for Schools, Cassell's. Illustrated throughout.
I.—Stories from English History, 1s. II.—The Simple Outline of English History, 1s. 3d. III.—The Class History of England, 2s. 6d.

Selections from Cassell & Company's Publications.

- Latin-English and English-Latin Dictionary. By J. R. BEARD, D.D., and C. BEARD, B.A. Crown 8vo, 914 pp., 3s. 6d.
- Little Folks' History of England. By ISA CRAIG-KNOX. With 30 Illustrations. 1s. 6d.
- Making of the Home, The: A Book of Domestic Economy for School and Home Use. By Mrs. SAMUEL A. BARNETT. 1s. 6d.
- Marlborough Books:—Arithmetic Examples, 3s. Arithmetic Rules, 1s. 6d. French Exercises, 3s. 6d. French Grammar, 2s. 6d. German Grammar, 3s. 6d.
- Music, An Elementary Manual of. By HENRY LESLIE. 1s.
- Natural Philosophy. By Rev. Prof. HAUGHTON, F.R.S. Illustrated. 3s. 6d.
- Painting, Guides to. With Coloured Plates and full instructions:—Animal Painting, 5s.—China Painting, 5s.—Figure Painting, 7s. 6d.—Flower Painting, 2 Books, 5s. each.—Tree Painting, 5s.—Sepia Painting, 5s.—Water Colour Painting, 5s.—Neutral Tint, 5s.
- Popular Educator, Cassell's. *New and Thoroughly Revised Edition.* Illustrated throughout. Complete in Six Vols., 5s. each.
- Physical Science, Intermediate Text-Book of. By F. H. BOWMAN, D.Sc. F.R.A.S., F.L.S. Illustrated. 3s. 6d.
- Readers, Cassell's Readable. Carefully graduated, extremely interesting, and illustrated throughout. (*List on application.*)
- Readers, Cassell's Historical. Illustrated throughout, printed on superior paper, and strongly bound in cloth. (*List on application.*)
- Readers, The Modern Geographical, illustrated throughout, and strongly bound in cloth. (*List on application.*)
- Readers, The Modern School. Illustrated. (*List on application.*)
- Reading and Spelling Book, Cassell's Illustrated. 1s.
- Right Lines; or, Form and Colour. With Illustrations. 1s.
- School Manager's Manual. By F. C. MILLS, M.A. 1s.
- Shakspeare's Plays for School Use. 5 Books. Illustrated, 6d. each.
- Shakspeare Reading Book, The. By H. COURTHOPE BOWEN, M.A. Illustrated. 3s. 6d. Also issued in Three Books, 1s. each.
- Spelling, A Complete Manual of. By J. D. MORELL, LL.D. 1s.
- Technical Manuals, Cassell's. Illustrated throughout:—Handrailing and Staircasing, 3s. 6d.—Bricklayers, Drawing for, 3s.—Building Construction, 2s.—Cabinet-Makers, Drawing for, 3s.—Carpenters and Joiners, Drawing for, 3s. 6d.—Gothic Stonework, 3s.—Linear Drawing and Practical Geometry, 2s.—Linear Drawing and Projection. The Two Vols. in One, 3s. 6d.—Machinists and Engineers, Drawing for, 4s. 6d.—Metal-Plate Workers, Drawing for, 3s.—Model Drawing, 3s.—Orthographical and Isometrical Projection, 2s.—Practical Perspective, 3s.—Stonemasons, Drawing for, 3s.—Applied Mechanics, by Prof. R. S. Ball, LL.D., 2s.—Systematic Drawing and Shading, by Charles Ryan, 2s.
- Technical Educator, Cassell's. Four Vols., 6s. each. Popular Edition, in Four Vols., 5s. each.
- Technology, Manuals of. Edited by Prof. AYRTON, F.R.S. and RICHARD WORMELL, D.Sc., M.A. Illustrated throughout:—The Dyeing of Textile Fabrics, by Prof. Hummel, 5s.—Watch and Clock Making, by D. Glasgow, 4s. 6d.—Steel and Iron, by W. H. Greenwood, F.C.S., Assoc. M.I.C.E., &c., 5s.—Spinning Woollen and Worsted, by W. S. Bright McLaren, 4s. 6d.—Design in Textile Fabrics, by T. R. Ashenhurst, 4s. 6d.—Practical Mechanics, by Prof. Perry, M.E., 3s. 6d.—Cutting Tools Worked by Hand and Machine, by Prof. Smith, 3s. 6d.

Other Volumes in preparation. A Prospectus sent post free on application.

Books for Young People.

- "Little Folks" Half-Yearly Volume.** With 200 Illustrations, 3s. 6d.; or cloth gilt, 5s.
- Bo-Peep.** A Book for the Little Ones. With Original Stories and Verses, Illustrated throughout. Boards, 2s. 6d.; cloth gilt, 3s. 6d.
- The World's Lumber Room.** By SELINA GAYE. Illustrated. 3s. 6d.
- The "Proverbs" Series.** Consisting of a New and Original Series of Stories by Popular Authors, founded on and illustrating well-known Proverbs. With Four Illustrations in each Book, printed on a tint. Crown 8vo, 160 pages, cloth, 1s. 6d. each.
- FRITTERS; OR, "IT'S A LONG LANE THAT HAS NO TURNING."** By Sarah Pitt.
- TRIXY; OR, "THOSE WHO LIVE IN GLASS HOUSES SHOULDN'T THROW STONES."** By Maggie Symington.
- THE TWO HARDCASTLES; OR, "A FRIEND IN NEED IS A FRIEND INDEED."** By Madeline Bonavia Hunt.
- The "Cross and Crown" Series.** Consisting of Stories founded on incidents which occurred during Religious Persecutions of Past Days. With Four Illustrations in each Book, printed on a tint. Crown 8vo, 256 pages, 2s. 6d. each.
- BY FIRE AND SWORD: A STORY OF THE HUGUENOTS.** By Thomas Archer.
- ADAM HEPBURN'S VOW: A TALE OF KIRK AND COVENANT.** By Annie S. Swan.
- The World's Workers.** A Series of New and Original Volumes. With Portraits printed on a tint as Frontispiece. 1s. each.
- CHARLES DICKENS.** By his Eldest Daughter.
- SIR TITUS SALT AND GEORGE MOORE.** By J. Burnley.
- FLORENCE NIGHTINGALE, CATHERINE MARSH, FRANCES RIDLEY HAVERGAL, MRS. RANYARD ("L.N.R.").** By Lizzie Aldridge.
- DR. GUTHRIE, FATHER MATHEW, ELIHU BURRITT, GEORGE LIVESEY.** By the Rev. J. W. Kirton.
- SIR HENRY HAVELOCK AND COLIN CAMPBELL, LORD CLYDE.** By E. C. Phillips.
- The "Chimes" Series.** Each containing 64 pages, with Illustrations on every page, and handsomely bound in cloth, 1s.
- BIBLE CHIMES.** Contains Bible Verses for Every Day in the Month.
- DAILY CHIMES.** Verses from the Poets for Every Day in the Month.
- MAJOR MONK'S MOTTO; OR, "LOOK BEFORE YOU LEAP."** By the Rev. F. Langbridge.
- TIM THOMSON'S TRIAL; OR, "ALL IS NOT GOLD THAT GLITTERS."** By George Weatherly.
- URSULA'S STUMBLING-BLOCK; OR, "PRIDE COMES BEFORE A FALL."** By Julia Goddard.
- RUTH'S LIFE-WORK; OR, "NO PAINS, NO GAINS."** By the Rev. Joseph Johnson.
- NO. XIII.; OR, THE STORY OF THE LOST VESTAL.** A Tale of Early Christian Days. By Emma Marshall.
- ABRAHAM LINCOLN.** By Ernest Foster.
- DAVID LIVINGSTONE.** By Robert Smiles.
- GEORGE MÜLLER AND ANDREW REED.** By E. R. Pitman.
- RICHARD COBDEN.** By R. Gowing.
- BENJAMIN FRANKLIN.** By E. M. Tomkinson.
- HANDEL.** By Eliza Clarke.
- TURNER, THE ARTIST.** By the Rev. S. A. Swaine.
- GEORGE AND ROBERT STEPHENSON.** By C. L. Matéaux.
- HOLY CHIMES.** Verses for Every Sunday in the Year.
- OLD WORLD CHIMES.** Verses from old writers for Every Day in the Month.

Selections from Cassell & Company's Publications.

New Books for Boys. With Original Illustrations, produced in a tint. Cloth gilt, 5s. each.

"FOLLOW MY LEADER;" OR, THE BOYS OF TEMPLETON. By Talbot Baines Reed.
FOR FORTUNE AND GLORY: A STORY OF THE SOUDAN WAR. By Lewis Hough.

THE CHAMPION OF ODIN, OR, VIKING LIFE IN THE DAYS OF OLD. By J. Fred. Hodgetts.
BOUND BY A SPELL; OR THE HUNTED WITCH OF THE FOREST. By the Hon. Mrs. Greene.

Price 3s. 6d. each.

ON BOARD THE "ESMERALDA;" OR, MARTIN LEIGH'S LOG. By John C. Hutcheson.

IN QUEST OF GOLD; OR, UNDER THE WHANGA FALLS. By Alfred St. Johnston.

FOR QUEEN AND KING; OR, THE LOYAL 'PRENTICE. By Henry Frith.

The "Boy Pioneer" Series. By EDWARD S. ELLIS. With Four Full-page Illustrations in each Book. Crown 8vo, cloth, 2s. 6d. each.

NED IN THE WOODS. A Tale of Early Days in the West.

NED ON THE RIVER. A Tale of Indian River Warfare.

NED IN THE BLOCK HOUSE. A Story of Pioneer Life in Kentucky.

The "Log Cabin" Series. By EDWARD S. ELLIS. With Four Full-page Illustrations in each. Crown 8vo, cloth, 2s. 6d. each.

THE LOST TRAIL.

CAMP-FIRE AND WIGWAM.

Sixpenny Story Books. All Illustrated, and containing Interesting Stories by well-known Writers.

LITTLE CONTENT.
THE SMUGGLER'S CAVE.
LITTLE LIZZIE.
LITTLE BIRD.
THE BOOT ON THE WRONG FOOT.
LUKE BARNICOTT.
LITTLE PICKLES.
THE BOAT CLUB. By Oliver Optic.

HELPFUL NELLIE; AND OTHER STORIES.
THE ELCHESTER COLLEGE BOYS.
MY FIRST CRUISE.
LOTTIE'S WHITE FROCK.
ONLY JUST ONCE.
THE LITTLE PEACEMAKER.
THE DELFT JUG. By Silverpen.

The "Baby's Album" Series. Four Books, each containing about 50 Illustrations. Price 6d. each; or cloth gilt, 1s. each.

BABY'S ALBUM.
DOLLY'S ALBUM.

FAIRY'S ALBUM.
PUSSY'S ALBUM.

Illustrated Books for the Little Ones. Containing interesting Stories. All Illustrated. 1s. each.

INDOORS AND OUT.
SOME FARM FRIENDS.
THOSE GOLDEN SANDS.
LITTLE MOTHERS AND THEIR CHILDREN.

OUR PRETTY PETS.
OUR SCHOOLDAY HOURS.
CREATURES TAME.
CREATURES WILD.

Shilling Story Books. All Illustrated, and containing Interesting Stories.

THORNS AND TANGLES.
THE CUCKOO IN THE ROBIN'S NEST.
JOHN'S MISTAKE.
PEARL'S FAIRY FLOWER.
THE HISTORY OF FIVE LITTLE PITCHERS.
DIAMONDS IN THE SAND.
SURLY BOB.
THE GIANT'S CRADLE.

SHAG AND DOLL.
AUNT LUCIA'S LOCKET.
THE MAGIC MIRROR.
THE COST OF REVENGE.
CLEVER FRANK.
AMONG THE REDSKINS.
THE FERRYMAN OF BRILL.
HARRY MAXWELL.
A BANISHED MONARCH.

Selections from Cassell & Company's Publications.

"Little Folks" Painting Books. With Text, and Outline Illustrations for Water-Colour Painting. *is.* each.

FRUITS AND BLOSSOMS FOR
"LITTLE FOLKS" TO PAINT.
THE "LITTLE FOLKS" PROVERB
PAINTING BOOK.
THE "LITTLE FOLKS" ILLUMI-
NATING BOOK.

PICTURES TO PAINT.
"LITTLE FOLKS" PAINTING BOOK.
"LITTLE FOLKS" NATURE PAINT-
ING BOOK.
ANOTHER "LITTLE FOLKS" PAINT-
ING BOOK.

Eighteenpenny Story Books. All Illustrated throughout.

THREE WEE ULSTER LASSIES.
LITTLE QUEEN MAE.
UP THE LADDER.
DICK'S HERO; AND OTHER STORIES.
THE CHIP BOY.
RAGGLES, BAGGLES, and the EM-
PEROR.
ROSES FROM THORNS.
FAITH'S FATHER.

BY LAND AND SEA.
THE YOUNG BERRINGTONS.
JEFF AND LEFF.
TOM MORRIS'S ERROR.
WORTH MORE THAN GOLD.
"THROUGH FLOOD — THROUGH
FIRE;" AND OTHER STORIES.
THE GIRL WITH THE GOLDEN
LOCKS.
STORIES OF THE OLDEN TIME.

The "Cosy Corner" Series. Story Books for Children. Each con-
taining nearly ONE HUNDRED PICTURES. *is.* 6d. each.

SEE-SAW STORIES.
LITTLE CHIMES FOR ALL TIMES.
WEE WILLIE WINKIE.
BRIGHT SUNDAYS.
PET'S POSY OF PICTURES AND
STORIES.
DOT'S STORY BOOK.

STORY FLOWERS FOR RAINY HOURS.
LITTLE TALKS WITH LITTLE PEOPLE
BRIGHT RAYS FOR DULL DAYS.
CHATS FOR SMALL CHATTERERS.
PICTURES FOR HAPPY HOURS.
UPS AND DOWNS OF A DONKEY'S
LIFE.

The "World in Pictures." Illustrated throughout. *2s.* 6d. each.

A RAMBLE ROUND FRANCE.
ALL THE RUSSIAS.
CHATS ABOUT GERMANY.
THE LAND OF THE PYRAMIDS
(EGYPT).
PEEPS INTO CHINA.

THE EASTERN WONDERLAND
(JAPAN).
GLIMPSES OF SOUTH AMERICA.
ROUND AFRICA.
THE LAND OF TEMPLES (INDIA).
THE ISLES OF THE PACIFIC.

Two-Shilling Story Books. All Illustrated.

STORIES OF THE TOWER.
MR. BURKE'S NIECES.
MAY CUNNINGHAM'S TRIAL.
THE TOP OF THE LADDER: HOW
TO REACH IT.
LITTLE FLOTSAM.
MADGE AND HER FRIENDS.
THE CHILDREN OF THE COURT.
A MOONBEAM TANGLE.
MAID MARJORY.

THE FOUR CATS OF THE TIPPER-
TONS.
MARION'S TWO HOMES.
LITTLE FOLKS' SUNDAY BOOK.
TWO FOURPENNY BITS.
POOR NELLY.
TOM HERIOT.
THROUGH PERIL TO FORTUNE.
AUNT TABITHA'S WAIFS.
IN MISCHIEF AGAIN.

Half-Crown Story Books.

MARGARET'S ENEMY.
PEN'S PERPLEXITIES.
NOTABLE SHIPWRECKS.
GOLDEN DAYS.
WONDERS OF COMMON THINGS.
LITTLE EMPRESS JOAN.
TRUTH WILL OUT.

SOLDIER AND PATRIOT (George
Washington).
PICTURES OF SCHOOL LIFE AND
BOYHOOD.
THE YOUNG MAN IN THE BATTLE
OF LIFE. By the Rev Dr.
Landels.
THE TRUE GLORY OF WOMAN.
By the Rev. Dr. Landels.

Selections from Cassell & Company's Publications.

- Library of Wonders. Illustrated Gift-books for Boys. 2s. 6d. each.**
 WONDERFUL ADVENTURES. | WONDERS OF WATER.
 WONDERS OF ANIMAL INSTINCT. | WONDERFUL ESCAPES.
 WONDERS OF ARCHITECTURE. | BODILY STRENGTH AND SKILL.
 WONDERS OF ACOUSTICS. | WONDERFUL BALLOON ASCENTS.
- Gift Books for Children. With Coloured Illustrations. 2s. 6d. each.**
 THE STORY OF ROBIN HOOD. | TRUE ROBINSON CRUSOES.
 OFF TO SEA. | REYNARD THE FOX.
 SANDFORD AND MERTON. | THE PILGRIM'S PROGRESS.
- Three and Sixpenny Library of Standard Tales, &c. All Illustrated and bound in cloth gilt Crown 8vo. 3s. 6d. each.**
 JANE AUSTEN AND HER WORKS. | SCHOOL GIRLS.
 BETTER THAN GOOD. | DEEPPDALE VICARAGE.
 HEROINES OF THE MISSION FIELD. | IN DUTY BOUND.
 MISSION LIFE IN GREECE AND PALESTINE. | THE HALF SISTERS.
 THE DINGY HOUSE AT KENSINGTON. | PEGGY OGLIVIE'S INHERITANCE.
 AT THE SOUTH POLE. | THE FAMILY HONOUR.
 THE STORY OF CAPTAIN COOK. | ESTHER WEST.
 THE ROMANCE OF TRADE. | WORKING TO WIN.
 THE THREE HOMES. | KRIF AND HIS FABLES. By
 MY GUARDIAN. | W. R S. Ralston, M.A.
 FAIRY TALES. By Prof. Morley.
- The Home Chat Series. All Illustrated throughout. Fcap. 4to. Boards, 3s. 6d. each. Cloth, gilt edges, 5s. each.**
 HALF-HOURS WITH EARLY EXPLORERS. | SUNDAY CHATS WITH OUR YOUNG FOLKS.
 STORIES ABOUT ANIMALS. | PEEPS ABROAD FOR FOLKS AT HOME.
 STORIES ABOUT BIRDS. | AROUND AND ABOUT OLD ENGLAND.
 PAWS AND CLAWS.
 HOME CHAT.
- Books for the Little Ones.**
 THE LITTLE DOINGS OF SOME LITTLE FOLKS. By Chatty Cheerful. Illustrated. 5s.
 THE SUNDAY SCRAP BOOK. With One Thousand Scripture Pictures. Boards, 5s.; cloth, 7s. 6d.
 DAISY DIMPLE'S SCRAP BOOK. Containing about 1,000 Pictures. Boards, 5s.; cloth gilt, 7s. 6d.
 LESLIE'S SONGS FOR LITTLE FOLKS. Illustrated. 1s. 6d.
- Books for Boys.**
 KING SOLOMON'S MINES. By H. Rider Haggard. 5s.
 THE SEA FATHERS. By Clements Markham. Illustrated. 2s. 6d.
 TREASURE ISLAND. By R. L. Stevenson. With Full-page Illustrations. 5s.
 HALF-HOURS WITH EARLY EXPLORERS. By T. Frost. Illustrated. Cloth gilt, 5s.
- MODERN EXPLORERS. By Thomas Frost. Illustrated. 5s.**
 CRUISE IN CHINESE WATERS. By Capt. Lindley. Illustrated. 5s.
 WILD ADVENTURES IN WILD PLACES. By Dr. Gordon Stables, M.D., R.N. Illustrated. 5s.
 JUNGLE, PEAK, AND PLAIN. By Dr. Gordon Stables, R.N. Illustrated. 5s.

CASSELL & COMPANY, Limited, London, Paris, New York and Melbourne.

