

GENERAL FOUNDRY PRACTICE

GENERAL FOUNDRY PRACTICE

Being a Treatise on General Iron Founding,
Job Loam Practice, Moulding and Casting of
the Finer Metals, Practical Metallurgy in
the Foundry, and Patternmaking from a
Moulder's Point of View

BY

WILLIAM ROXBURGH, M.R.S.A.

Foundry Manager, Kilmarnock



NEW YORK

D. VAN NOSTRAND COMPANY

23 MURRAY AND 27 WARREN STREETS

1910

TS 230
R7

LIBRARIAN'S FUND

PREFACE

MANY years' experience as a moulder and foundry manager has demonstrated to the author the need there is for such a book as here presented, which is based on the modern lines of theory and practice combined, and which contains nothing but what has passed through the author's own hands, during an experience of over thirty years.

The whole work is light and practical reading, and is intended to give the greatest amount of information on foundry methods, materials, and metals, with the least possible study.

A book such as this, although primarily intended for moulders and founders of every description, is also written for draughtsmen, patternmakers, and the engineering profession in general.

As a text book it will be most interesting to many students of metallurgy and users of metals, who either cast or construct. Nevertheless, to some it may show but little new in founding, and probably something which may be objected to. Still, on the other hand, there may be just as many, nay more, to whom the book may, at least, be a source of relief in times of difficulty, and to such, and all that are interested in the abstruse problems of founding in its many phases is this book specially commended.

The author thankfully acknowledges his indebtedness to *The Ironmonger* for the use of the following articles, from his pen, which appeared in recent issues of this Journal, all of which have been more or less amended for this work:—
“Starting a Small Iron Foundry,” “Metal Mixing and its

Adaptation," "Starting a Small Brass Foundry," "Aluminium Castings and Alloys," "Moulding for Aluminium Castings," "~~Malleable-Cast.~~"

Like~~w~~ise, the author's special thanks are due to the several pig-iron manufacturers whose analyses are herein recorded, for specially preparing those analyses which in every case are up-to-date, and specially sanctioned for publication in this work.

Lastly, the author's thanks are also due to Mr. O. F. Hudson, M.Sc., of Birmingham, for assistance given in the form of editing this work, and this particularly applies to the chapters on "Practical Metallurgy in The Foundry" and "Fluid Pressure."

WILLIAM ROXBURGH.

KILMARNOCK,
January, 1910.

CONTENTS

DIVISION I

GENERAL IRON FOUNDING

	PAGE
Starting a Small Iron Foundry	1
Moulding Sands	14
Location of Impurities	23
Core Gum	27
Blow Holes	29
Burning Castings	32
Venting	35
The Use of the Riser in Casting	38
Chaplets	42
Shrinkage	44
Pressure of Molten Iron (Ferro-Static Pressure)	57
Feeding or the Compression of Metals	63
Metal Mixing	71
Temperature	79
Defects in Cast-iron Castings	83
Special Pipes (and Patterns)—Green-Sand and Dry-Sand	87
Core Clipping	108
Machine and Snap Flask Moulding	113
Moulding Cylinders and Cylinder Cores	116
Jacketed Cylinders	125
Core-Sands	135
Moulding a Corliss Cylinder in Dry-Sand	139
General Pipe Core Making	146
Chilled Castings	153
Flasks or Moulding Boxes	158
Gates and Gating	165

DIVISION II

JOBGING LOAM PRACTICE

Loam Moulding	173
Moulding a 36" Cylinder Liner	177

	PAGE
Moulding a Slide Valve Cylinder	182
Moulding a Cylinder Cover	186
Cores and Core Irons for a Slide Valve Cylinder	188
Moulding a Piston	191
Loam Moulding in Boxes or Casings	194
Moulding a 20' Loco. Boiler-Front Cross-Block	196
The Use of Ashes and Dry-Sand in Loam Moulding	199

DIVISION III

MOULDING AND CASTING THE FINER METALS

Starting a Small Brass Foundry :—Furnaces; Waste in Melting; Moulding; Temperatures; Brass Mixtures, etc.; Draw and Integral Shrinkage; Position of Casting and Cooling the Castings	203
Bronzes:—Aluminium; Phosphor; Manganese, and running with the Plug gate	215
Casting Speculums:—The Alloy; Draw; Treatment of Castings; Compression and Annealing; Melting and Pouring; Moulding Aluminium Founding :—Scabbing; Sand; Gating; Risers; Melt- ing; and Temperature	217
Aluminium Castings and Alloys	227
“Malleable-Cast”	230
<hr/>	
Practical Metallurgy in the Foundry	233
General Patternmaking from a Moulder's Point of View	246
Foundry Ovens and their Construction	268
Fuels	274
Foundry Tools	279

LIST OF ILLUSTRATIONS

FIG.	PAGE
1. Plan of Small Foundry	4
2. Elevation of Small Foundry	4
3. Plan of Offices and Stores	4
4. Plain Top-part	7
5. End Elevation of Top and Bottom Boxes	7
6. Pattern for Box Handles, Figs. 4 and 5	7
7. Box-part Piece for Columns and Pipes	8
8. Handle Pattern and Core for Crane Boxes	8
9. Swivel Core for ditto	8
10. Box-Bar Pattern	8
11. Moulding Tub for Light Castings	9
12. 24-in. Cupola for Light Castings	12
13. Marking Table Casting	24
14. Elevation of Table Casting	24
15. Sectional End Elevation of Barrel with Dirt Receptacle on Top	25
16. Blowhole on Topside of Pipe Casting	30
17. Plan of Pipe showing Blowhole	30
18. Sectional Elevation showing Blowhole	30
19. "Burned" Shaft	33
20. Section of Shaft	33
21. "Burned" Pipe Flange	34
22. Cross Section of Mould, showing Vents	36
23. Longitudinal Section of Flange Pipe and Basins	39
24. Longitudinal Section of Pipe or Tube with Basins	39
25. Plan of Diagonal Ribbed Box	48
26. Plan of Double Diagonal Ribbed Box	48
27. Tank Plate	49
28. Square-ribbed Box	49
29. Cross Section of Soleplate Leg	51
30. Cross Section of Box Soleplate Leg	52
31. Sectional Plan of Loam Cylinder Mould	56
32. Sectional Elevation of Cylinder Loam Mould	57
33. Cross Section of Mould and Box with Lifting Pressure Diagram	60
34. Section of Solid Cubes for Pressure Calculation	61
35. Section of Square Cube without Ends	62
36. Longitudinal Section of Double Flange Pipes	66
37. Section of Plate with Hollow and Solid Bosses	68

FIG.	PAGE
38. Ingot Casting when Fluid	70
39. Ingot Casting when Solidified	71
40. Cross Section of Pipe	77
41. Cross Section of Plate	77
42. Cross Section of Pipe	77
43. Cross Section of Plate	77
44. Barrel with part of Flange removed	81
45. Elevation showing Defect in Bore	81
46. Section of Plate in Mould with "Dumb-scab"	83
47. Vertical Cast Ram	85
48. Cylinder Cover (Disproportionate Metal)	86
49. Cylinder Cover (Proportionate Metal)	86
50. S. Pipe Core Plate (wood)	89
51. Core Sweep	89
52. Section of Core	89
53. Flanged Skeleton Pattern	89
54. Mould Sweep	89
55. Air Vessel Pattern (Boss)	92
56. Section of an Air Vessel Core	94
57. Longitudinal Section of Bottle-necked Pipe	96
58. Bell-mouthed Pipe	97
59. Stool Bend Pipe	100
60. End Elevation of Stool Bend	100
61. Core Iron and Plate for Bend Pipes	101
62. Cross Section of Core	101
63. Cross Section of Plate and Half Core	101
64. Longitudinal Section of Pump Pipe Box, Mould and Core, etc.	104
65. Longitudinal Section of Pump Pipe cast on "The Bank"	106
66. Gates and Risers on Flange	107
67. Cross Section of detached Core Clips (double)	109
68. Core Clips attached	111
69. Cross Section of Core Clips attached (double)	112
70. Longitudinal Section of Cylinder with Sinking-head	122
71. Cross Section of Cylinder with Arrows on Spongy Parts	123
72. Sectional Elevation of Jacket Cylinder Core before Dressing, etc.	128
73. Corliss Cylinder (half pattern) in Moulding Box	140
74. End Elevation of Corliss Cylinder Box Mould and Cores	141
75. End Elevation of Corliss Cylinder Cores	143
76. Exhaust Cylinder Core joining Port Cores at Arrows	144
77. Plan of Bend Pipes without Stangey	148
78. Section of Bank Pipe Core	149
79. Part of Cross Section of Vertical Pipe Core Bar	152
80. Elevation of Chilled Anvil Mould	153
81. Plan of Top-Part for Half-wheels, etc.	160
82. Segment Pattern of Pulley Box	161
83. Five-part Box with Mould	162

LIST OF ILLUSTRATIONS

xi

FIG.	PAGE
84. Half-Duplex Vertical Pipe Casing	163
85. Sectional End Elevation of Pipe Casing	163
86. Small Wheel with Worm Gate	166
87. Spur Wheel with Fountain Gate	167
88. Loam Condenser with Bottom Gates	169
89. Loam Cross with Spindle	173
90. Plan of Cross and Spindle	173
91. Sectional Elevation of Cylinder Liner	178
92. Bottom Cylinder Liner Plate Drawn off on "Bed"	178
93. Bottom Bearing Sweep for Cylinder Liner	179
94. Top Cake Sweep for Cylinder Liner	179
95A. Top Cope Gauge for Cylinder Liner	179
95B. Core Gauge Stick for Cylinder Liner	179
96. Cylinder Liner	180
97. Sectional Elevation of Cylinder Liner Top Cake	181
98. Sectional Elevation of Slide Valve Cylinder Loam Mould	183
99. Plan of Bottom Plate and Building Rings for Slide Valve Cylinder	183
100. Sweep Stick for Bottom Bearing of Slide Valve Cylinder	184
101. Gauge Stick for Steam Port Core	185
102. Exhaust Core for Slide Valve Cylinder	185
103. Sectional Elevation of Cylinder Cover	186
104. Sweep Stick for Cylinder Cover	187
105. Sweep Stick for Cylinder Cover Top Cake	187
106. Section of Steam Port Core Box	189
107. Plan of Core-iron for Steam of Slide Valve Cylinder	189
108. Sweep Stick for Steam Port Core Box	189
109. Section of Lightening Core Box	189
110. Section of Exhaust Port Core	190
111. Section of Steam Chest Core Box and Core	190
112. Sectional Elevation of Piston Loam Mould	191
113. Piston Top-Cake Sweep	192
114. Piston Bottom Board	192
115. Piston Plug Core Box	192
116. Web or Arm Board for Piston	193
117. Plan of Piston showing Gates and Plug-holes	193
118. Plan of Core-irons for Piston	193
119. Sectional Elevation of Piston and Moulding Box	195
120. Plan of Cress-Block and Moulding Box	196
121. Elevation of Cress-Block and Moulding Box	197
122. Circle Sweep for Cress-Block	198
123. Plan of Sweep for Cress-Block	198
124. Guide for Sweep Fig. 123 Cress-Block	198
125. Skeleton Pattern Curve for Cress-Block	199
126. Sectional Elevation of Brass Furnaces	204
127. End Elevation of Brass Furnaces	205

FIG.	PAGE
128. Cross Section of Moulding Tub for Brass Foundry	206
129. Elevation of Brass Casting and Moulding Box, showing Shrink Cavities (vertical position)	211
130. Sectional Elevation of Box and Casting (horizontal position)	212
131. Section of Speculum, showing Shrink Cavities	218
132. Section of Speculum (Improved Density)	219
133. Tensile Test Bar	245
134. Sectional Elevation of Cast-iron Spigot and Faucet Pipe Pattern	248
135. End Section of Cast-iron Bank-pipe Core-box	250
136. Longitudinal Section of Shell Stucco Pattern	254
137. Sectional Elevation of Stucco Block Board and Sweep	254
138. Longitudinal Section of Stucco Faucet Mould	255
139. Sectional Elevation of Stucco-Block and Sweep	258
140. Iron Frame for Sweeping Spigot and Faucet Pipe-Mould	259
141. Body Sweep	260
142. Revolving Faucet Sweep	260
143. Pivot Frame Sweep for Fig. 142	260
144. Elevation of Mould Sweep	261
145. Elevation of Core Sweep	261
146. Cross Section of Core, Mould, Sweep, and Box	261
147. Sectional Elevation of Reduced Mould and Original Pattern	263
148. Elevation of Cutting Stick for Spur-Wheels	264
149. Sectional Elevation of Increased Mould and Original Pattern	265
150. Sectional Elevation of Reduced Capped Spur Wheel and Original Pattern	266
151. Sectional Elevation of Increased Capped Spur Wheel and Original Pattern	268
152. Sectional Side Elevation of Foundry Oven Fire	270
153. Sectional Elevation of Oven Roof	271
154. Front and End Elevation of Moulder's Beam	280
155. End Elevation of ditto	280
156. Stirrup Hook for Swivel Boxes	281
157. Cast Iron Clamp	282
158. End Elevation of Ringer and Binder	283
159. Cross Section of Stool	284
160. Screw Hook for Slings Cores, etc.	285
161. Double Shifting Hooks	286



FACTS ON GENERAL FOUNDRY PRACTICE

DIVISION I

GENERAL IRON FOUNDING

STARTING A SMALL IRON FOUNDRY

THE starting of an iron foundry may seem at first sight to many a simple affair, but bearing in mind the wide range of a jobbing foundry's requirements in matters of convenience, site, and equipment it will be found to involve a great deal of careful thought and consideration.

Small foundries are to a great extent in city life a thing of the past, but here and there the necessity arises for such, especially in a thriving agricultural district ; and such foundries are still, and always have been, an indispensable adjunct to a successful country engineering works. It is not intended to choose any particular class of founding, or to go deeply into the question of the amount of capital required for starting business on the lines suggested, but simply to try to outline what sort of foundry is required for an output of 5 or 6 tons per week of jobbing castings, under normal conditions such as are known to practical men. In the event of the would-be foundry master deciding to build, the judicious selection of a suitable place for the foundry is of paramount importance. The cartage or handling of all raw materials, such as sands, coal, coke, pig iron, etc., and the finished product, castings, is a serious item in the working expenses of a foundry, and means money lost or won in proportion to the care exercised in selecting the best possible site. Other things

being equal, this point has the greatest possible influence in determining the success or failure in the working of foundries whether large or small.

In the foregoing we have many reasons influencing the position of the building, but along with these we must study the conditions below the surface. Many have unwittingly built foundries, especially of the class doing heavy work, where pits for casting are an absolute necessity, and have found to their cost afterwards that a great mistake had been made through want of care in selecting the site. At the first digging of a pit they have been surprised by encountering water at a depth of 4 or 5 ft., which throughout was troublesome, and before such pits could be made secure iron tanks suitable for the work in hand had to be made and sunk, thus securing absolute freedom from water. Hence all foundries should be drained thoroughly round their outsides to a depth sufficient to discharge automatically any water in the floor. The lowest level of the floor should, if possible, be taken from the highest level of the water, and if there be 3 ft. between this and the highest floor level, and more is required, the top level of the floor should be raised to give the required depth. In some cases such an arrangement would prove an advantage, since cupola slag and other rubbish could be dumped round the outside walls of the foundry. Of course, where moulding is entirely of the turnover or machine class, and no bedding-in is done, drainage is of no consequence practically.

Building.—The next point to decide is the structure, whether it shall be of wood, brick, stone, or iron, or a combination of all these materials. This question is often settled by the amount of capital available, but whatever the structure be, it must be wind and water-tight, as it is of the utmost importance to protect moulds from rain or frost, while with a dry atmosphere is as troublesome to some green-sand moulders as excessive dampness and cold. If all the work done in green-sand by moulders in large or small foundries could be executed at a uniform temperature of about 50 or 60° Fahr., the advantages to be gained from such conditions of working would more than meet the outlay attending the heating of

some of our large foundries in winter, while in not a few cases the cost of improved ventilation would be more than compensated for during the summer months by increased output. It is an undoubted fact that the better the conditions under which men have to work in the foundry, the greater are the profits to the employer for wages paid, other things being equal.

Water.—Having duly warned the intending ironfounder against an excess of water, we now proceed to insist upon a sufficient supply, for this is indispensable in the foundry for watering and mixing the sand after castings have been taken from the floor, and for use in the making of loams, etc. If steam be the motive power of the works the cost of water for boiler feeding purposes is also a matter for serious consideration. Water, then, at even the cheapest possible rate means much in the foundry. The advantages of starting a small country shop in a good agricultural locality, where it is possible to build near a running stream, and yet at the same time to be free from risk of trouble with the foundry floor, will be obvious, but the opportunities of so starting are few. Where such a plan is practicable, all motive power for blast, etc., could be secured by the use of a water wheel or turbine, besides having an abundant supply of water for all foundry purposes. Such an arrangement of the foundry would go a great way in compensating for the inconvenience of country situation when compared with the production of castings in a city where rents and taxes are abnormally high.

Fig. 1 shows the ground plan of a foundry, 40 ft. by 28 ft., which should give ample room for the production of 5 or 6 tons of jobbing castings per week. This output is computed on the basis of alternate-day meltings, but it may be considerably increased by casting daily. Some small shops do well on the former, others may do better on the latter; it is all a question of how far it may concern individual cases, having regard to circumstances and economy. In Fig. 1, *A* is the derrick crane; *B* the cupola and spout or runner, led inwards through the wall of the foundry; *C* is the stove for drying cores and moulds; *D* the fire-hole; *F* the small shop suitable for making cores, mixing sands, shelving core-boxes and patterns, and containing the core-stove *E*; *G* are columns for

carrying the structure; *H* the moulding-tub; *I* the smithy and dressing shop; *J* (Fig. 3) is the office; *K* the clay mill shed; *L* the pattern shop and store. Fig. 2 shows the columns *G* with the traverser-bracket *M* cast on. These details are only the bare outlines, and the offices attached may or may not be required. Whatever motive power is decided

upon care must be taken to see that the fan shall be placed to blow as directly as possible at, say, a distance of 20 or 30 ft. from the cupola. On the question of materials for the construction, the most up-to-date plan is to begin by planting the columns on concrete or stone foundations at suitable distances, to ensure safety for carrying the roof. These columns are usually *H* section, and are made with suitable projections or brackets for carrying the rails of the traverser crane. The brackets add but little to the cost of the columns, and may either be cast on, or provision may be made for bolting them on at some future occasion. This is a matter for consideration at the outset even if a "traveller" is not then put in.

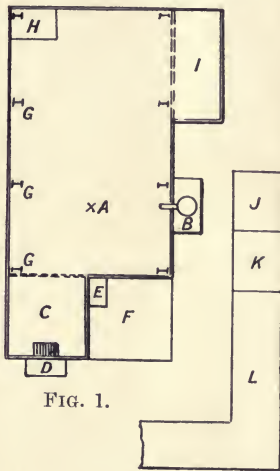
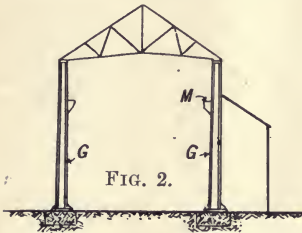

FIG. 1.

FIG. 3.

With a foundry on a still smaller scale than the one we have before us an *H* joist or beam might be erected in line with the spout of the cupola across the shop after the fashion of an overhead rail. A block and tackle fixed on this, and capable of being shifted sideways, would in some measure meet the want of crane power incidental to a small country shop. But with the foundry built of columns, as shown in the end view (Fig. 2), and with sides and ends either brick or

corrugated iron, a small "traverser" could be placed on rails suitable for the heaviest box or ladle likely to be in use.

A derrick crane requires substantial walls for binding the crane thereto, but this is not the case with the traverser because there is no side thrust set up by its working. In the ground plan (Fig. 1) we have only shown two doors—first, the large door on the side next the cupola *B*, and second, the door on the side wall of the smithy and dressing or fettling shop. For obvious reasons the sizes are not specified, and others may be arranged for whenever such may be thought necessary.

The Foundry Floor.—To a practical moulder this does not present many difficulties; he would simply clear out the bottom to the depth required, and so prepare it for the floor sand. The question of the cost and quality of moulding sand, however, is an important one when starting a new foundry, and much depends on local conditions and the distance of the pits or quarries from the foundry. In selecting a sand or sands for moulding no particular lines can be laid down for the guidance of the non-practical man. A sand suitable for one class of work may possess all the properties which go to make a good sand for moulding in the eyes of some men, and yet might be condemned for the same class of work by other and equally good moulders. Such is the prejudice of experience gained under different conditions. However, the distinctive qualities for practical moulding are plasticity and porosity. The sands best known in the British Isles may be said with comparative safety to be "London," "Belfast," and "Scotch rock." Equal parts of these sands would make a fairly good floor for general work, and if we keep to the distinctive characteristics given, it matters not whether it be black, brown, red, or yellow, the safety of selecting a sand for moulding purposes is practically assured. The dividing lines between green sand, dry sand, facing sands, etc., are fully dealt with in "Moulding Sands," (p. 14). Hence it will be observed that, while the sands as suggested are stipulated as a guide for the making of a foundry floor, it nevertheless leaves the way clear to adapt whatever sands may be locally accessible for moulding purposes.

In order to start the operations of moulding, the floor may

be filled to a depth of 9 to 12 ins., and, should a greater depth be required for special work it is only a matter of digging, additional sand being added from time to time as required for such work. This method of forming a floor for a small foundry is perfectly good, but must not be taken as applying to foundries that are intended for heavy work, in which case depth would be controlled according to work anticipated. But, whether with large or small foundries, floor making is really the result of work done and the methods of doing it. Moulding sand is generally *computed* for at 1 cwt. per cubic foot when compressed by ramming; but in view of the moisture, etc., in it, this is but a rule-of-thumb way of making the calculation. Fifty or sixty tons of sand might suffice for forming the floor of the shop in question. Under such circumstances the floor would be in a virgin condition and comparatively free from coal dust or other carbonaceous matter. Therefore 10 to 15 per cent. of coal dust properly mixed with it would be an advantage. This is not imperative, because this proportion of coal dust could be added to each batch of facing sand until the floor had developed by the process of casting.

Cranes and Boxes.—In the selection of plant for a jobbing foundry, some idea must be formed of the work likely to be done. Something has already been said about crane power. A derrick with the capacity for lifting 2 or 3 tons should, in a general way, do all that is required. It may either be of wood, steel, or iron, of T, L, or H sections plated. It should have quick and slow motions, which are preferable with hand-power cranes. If, however, the crane is smaller than suggested, a single-gearred motion midway between the ratios of a quick and slow type will prove cheap and handy. In the matter of boxes, everything depends upon the nature of the shop and work to be done in it.

Although here and there an odd wooden flask may be found, iron flasks are almost exclusively used in this country. In America, on the other hand, the use of wooden flasks was until recently practically universal; but the iron flask is now becoming very popular, and has in some cases entirely superseded the wooden flask. Whether of wood or cast iron, the

design of boxes is much the same, although the details of construction vary considerably. It will be assumed that the boxes are to be cast in the usual way, and a few leading features illustrated. Thus, Fig. 4 shows a top-part box 2 ft. by 2 ft. by 6 ins. ; Fig. 5, both the drag and top part in end elevation ; while Fig. 6 represents the handle pattern, which is simply entered from the inside, as may be noticed in both parts of Fig. 5. When ram-

ming up the bars of Fig. 4, place a trowel, or something else suitable, over the four holes in the pattern, and thus save the sand from finding its way through and wasting the handles during the process of ramming up the box bars, as seen at Fig. 4. Of course the handles might be made of wrought iron ; but if this were done, $\frac{3}{8}$ in. or $\frac{1}{2}$ in. extra thickness of metal would need to be added where the dotted lines are shown in the top and drag of Fig. 5. In making this pattern the bars should be made up with screws, so that the outside frame might be used to make both halves

economically by transposing the top bars to the bottom, or *vice versa*.

Crane work in the smallest of foundries is often indispensable, and therefore crane boxes must be employed at times. With this class of box plant, if a foundryman understands his business, the cost of pattern-making can be kept at a minimum by ignoring the principle of complete patterns. For instance, for large, square, or oblong boxes, the whole or part of the outside frame may be bedded in the floor to the size wanted. With an outside frame and two or three parallel bars running lengthwise, and set to the length of bars wanted, and three or four more cross-bars of the length indicated, a moulder

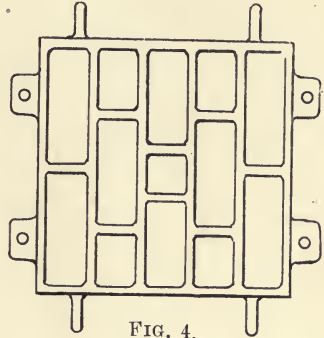

FIG. 4.



FIG. 5.



FIG. 6.

who knows his work will make boxes of this class to any size with greater ease and economy than from a complete pattern. All internal bars should be chamfered on the lower edges, and be kept $\frac{3}{8}$ in. or $\frac{3}{4}$ in., as the case may be, less in depth than the outside frame of the box (see Fig. 5).

Again, small foundries, such as the one we have in mind, make occasionally a few columns; and, indeed, the capacity of such a shop is ample for casting, if need be, two per day, say 15 ft. long, provided the weight does not exceed the melting capacity of the cupola. If the core-stove should not be long enough for drying a full-length core, it could be made

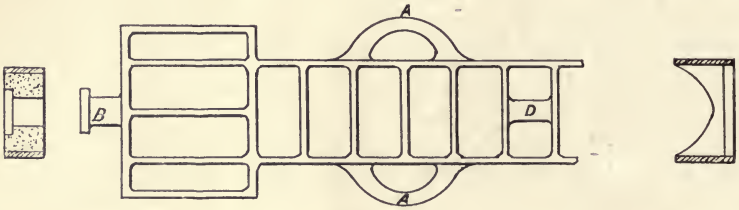

FIG. 9.

FIG. 7.

FIG. 10.



FIG. 8.

conveniently in two separate lengths, a method not at all uncommon in jobbing moulding shops.

Fig. 7 represents a column box which might be cast in sections, one body and two ends—the three parts being fitted together to make it handy for lengthening if required. A column box, however, is better cast in one piece where repetition work is assured; consequently it becomes a matter for decision as to which is the more economical in the way of present requirements or prospective business. Handles and swivels (*A, A* and *B* in Fig. 7), either or both of which may be used, should be “cast on,” or wrought-iron ones may be employed. If cast iron is adopted—and this is, as a rule, the handiest and cheapest way—Figs. 8 and 9 show how the core-blocks are formed. These, when taken from the box in which they are rammed up, are blackwashed, dried, and planted at *A, A, B* (Fig. 7) during the process of moulding. Fig. 8, *C*, shows how the handle pattern should be cut in halves for the convenience of “drawing.” Fig. 10 is a sketch of the box

bars, in moulding which a set may be fitted in the pattern frame of the box at 6-in. centres, or three or four loose bars may be used and shifted during the moulding of the boxes after the fashion already referred to with the larger ones, *D* is known as a stangy bar, and is made of flat iron, cast in the box, as shown at Fig. 7.

Tub Moulding.—Fig. 11 shows a moulding “tub” for small work, for use with which it is necessary to have light and handy boxes. Much might be said for tub moulding as against floor moulding; but as it is intended in this work on Foundry Practice to deal with things in the most concise way possible, it can only be referred to as an auxiliary method which relieves the ordinary light and medium greensand moulding, and allows better organisation. It may be said, however, that with

a tub the moulder gets about his work in a way not possible when moulding on his knees on the floor. He has better light, and can handle himself and his work to much greater advantage; his sands are more select, and the many small tools employed in the



FIG. 11.

moulding of this class of work are always within his reach. These conditions all combine to give better work, and more of it, than is possible with the same class of work on the floor. With a tub there should be boards suitable for the sizes of boxes, as the boxes have no bars cast in them: the boards are indispensable for the handling of the boxes, thus removing all danger of damage to the bottom box when placing it on the floor for pouring. The tub should be made of wood, as represented in Fig. 11, its length being anything from 4 ft. upwards.

Boxes.—Three good sizes are 10 ins. by 10 ins. by 4 ins.; 18 ins. by 12 ins. by 5 ins.; 15 ins. by 11 ins. by 5 ins. They should be light, and the smallest size may have handles of $\frac{3}{8}$ in. round iron cast in them. A better job, however, is made when the sides are drilled and the handles fitted. These should be made to template, and the pins turned,

and all made interchangeable. However, small boxes of, say, 12 ins. to 18 ins. square may be cast with bow handles, which, of course, are made with cores, in the same way as the handles *AA*, Fig. 7, and snugs with cast-iron pins cast on one half and snugs with pin holes on the other. This method of making a box does away with machining and fitting, and may be adapted to plate moulding, where only a flat surface top part is required. The latter type is, of course, of special design.

Cupolas and Melting.—It is generally admitted that no branch of foundry practice is of more interest than that which belongs to the cupola. A good going cupola is the backbone of a foundry, and without such no place can ever be made to pay. In these days we have so many ideas in the market, all ostensibly for melting at the cheapest rate possible, that to the inexperienced man it becomes a bit of a puzzle to know what to do for the best.

It is a matter of no particular moment whether we regard, for the purpose of the foundry in question, a cupola with blast belt and its distribution of tuyers, or one or two blowing direct from the fan as previously suggested. We have seen many fakes of cupola shells, made from old boiler shells, or such like, that the cost of a cupola on those lines need not be taken too seriously. Indeed, the author has seen much good work done with a cupola of the dimensions of Fig. 12, the shell of which had been made of such material. This cupola was blown by a fan of very primitive type which had only four blades, and yet such a contrivance gave out a blast pressure of fully 10 ins. W.G. through a 6-in. pipe. Under normal conditions metal came down within ten or fifteen minutes after blowing.

It is not necessary for the present to go into the details of tuyer belts and their proper distribution, or to discuss the utility of receivers which are said to be capable of melting more metal at a greater heat with a less consumption of coke than is possible with the old style of cupola practice. But the chief precaution to be observed in designing cupolas is to secure simplicity of form, combined with a capacity for giving the greatest possible melt at the least possible cost. In buying a

cupola there is great need for care, lest the unwary be over-persuaded by the specialist who has a habit of promising that he can melt iron for next to nothing. In contracting for a cupola it should be specified that the iron melted shall be of the maximum of heat for the different moulds common to the work of an ordinary jobbing foundry. If this be not definitely stated at the outset, buyer and seller may disagree in the end, when perhaps it is too late for the buyer to obtain redress.

Modern cupolas have double-row tuyers, triple-row tuyers and serpentine tuyers, all of which may or may not have receivers. They may have either solid or drop bottoms, any one of the patterns being probably furnished with the tuyer belt. In spite of the many merits of the types mentioned, truth compels the statement that not one of them is commendable for a small country shop. Greater economy and better results from any point of view are produced by one or two tuyers on a cupola of, say, 24-in. inside diameter, blowing direct from the blast pipe into the cupola, fan and cupola being distanced as before mentioned. By adopting the "solid bottom" the cupola upkeep is relatively less than is possible with the "drop," and, moreover, the solid bottom is comparatively safe against explosions or disasters, such as are too well known with the working of the drop bottom. Fig. 12 represents a cupola suitable for the shop we are describing. It should be 24 ins. internal diameter. *A* is the brick base or foundation, which is solidly built, and forms the bottom hearth, where the shell of the cupola is planted. *B* is the cleaning-out door, which must be made of suitable dimensions to allow the cupola man easy ingress for the purpose of chipping and fettling the lining, etc. This door ought to be on the outside of the cupola, for thereby is avoided much of the inconvenience experienced with some old types that have to be drawn or cleaned from the inside of the foundry at the end of the day's cast. *C* is the tapping hole. *D* are the tuyers. There may be two, but one is sufficient to supply the blast for a cupola of this size. *E* is the charging door, and *F* the platform. The outside diameter of the malleable shell may be determined by the thickness of lining—that

is, whether there are to be two rows of 4-in. or 5-in. bricks or only one. Although, one row of brick is quite common in cupolas of this size, a lining two bricks thick will prolong the life of the cupola shell considerably. Again, when melting, if we want a better mixing than can be got by direct tapping into the ladles that are in use during the cast, the metal may be tapped into a shank ladle, from which small

ladles can be supplied throughout the heat. This will mix metal better than is possible with the dribbling motion of melted metal, passing from the cupola to its receiver wheresoever the latter may be employed.

The objection may be raised that Fig. 12 illustrates a type which represents neither modern American nor German methods, nor up-to-date British practice. Drop bottoms have many admirers, but those with the longest experience are not likely to put a drop bottom in the place of a solid one; and, indeed, we have seen the "drop" displaced by the solid, and the change was always followed by satisfactory results.

The height of the cupola is

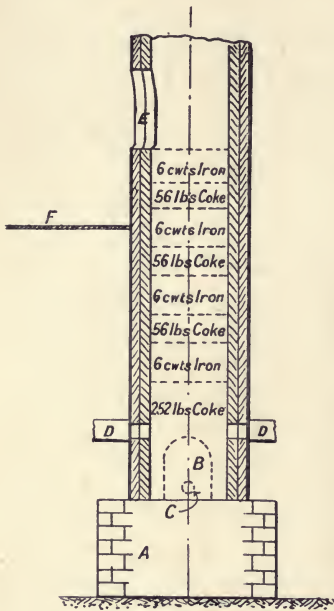

FIG. 12.

not given, because this will be determined by the circumstances of the situation, as it concerns the safeguarding of the roof and adjacent buildings from fire.

Before commencing to charge with iron, we should be satisfied that the coke in the hearth, which at this time should form the bed complete, is kindled above the tuyers, otherwise the delay of melting our first charge will be serious—that is to say, if the blast be turned on before the requisite height of flame from the bottom bed of coke be attained. When satisfied that the cupola is properly kindled we begin to charge,

and following the instructions as herein given, any one should be able to do it.

Ordinary care must be exercised with the quantities stipulated, and attention paid to the levelling of the charges of coke and iron throughout the process of charging and melting. The furnace man should see that the coke is of medium size and also have the pigs broken in six pieces, and make sure that the scrap is of proportionate bulk also. Attention to those points minimises the chances of "bunging," or retarding in any way the melting ratio of the cupola. Three or four pounds of limestone, or some such flux, to every second or third charge will improve the metal and assist in fluxing or washing down, as it were, the sides of the cupola, which in turn facilitates the process of raking out the cupola at the end of the melt; but, of course, the chief work of a flux is to judiciously cleanse the metal of its impurities.

Moulding and Fettling.—These are matters of shop practice which call for much care in discipline and organisation. Suffice it to state that both must be attended to with discretion, so as to get good and economical work done, and experience has often shown that the lowest-paid is the costliest man when output and not wages are compared.

In selecting a moulder as working foreman, see that he is a thoroughly practical man who has his practice backed up by sound theoretical knowledge. Such a man is far better qualified to work any place, whether large or small, than one who relies on chance and physical force to pull him through. The day has passed for the man who knows only how to dig holes, pound sand, finish moulds and cast, and who leaves the rest to chance. Indeed, in order to work successfully any concern, a man must be capable of seeing at least the bulk of his work done before it is commenced, otherwise he cannot be said to have the necessary ability to lead men through the many perplexities of an ordinary jobbing foundry. Organisation, discipline, method and diligence, with respect for superiors and inferiors, ought to be the guiding principles of any man responsible for the working of a foundry, if he is to make it pay.

MOULDING SANDS

The material known as moulding sand is so widely employed for moulding purposes that it is essential that suitable sand should be obtained wherever the craft of moulding is practiced. In some localities there are abundant natural supplies of material quite suitable; in others not so highly favoured in this respect the material must be adapted to suit the moulder's requirements or procured from elsewhere. The following is intended to give an outline of what should constitute good moulding sand, so that the practical man may compound the constituents for himself whether the material be required for core-making, in all its varied forms, or for moulding.

At the outset it may be said that uniform practice is impossible, for every locality is more or less governed by local conditions, namely, the character of the work to be done and the material available. In one locality there may be found sand having too much clay, causing it to be too plastic, while in another may be found a sand which is poor in plastic matter, but which is gritty and porous; and, while neither of the two is suitable for moulding by itself, probably equal parts of each would make a first-class sand.

The chemical analyses are very varied. Moulding sand is composed of silica, aluminium silicate, and oxides of iron and other elements. Sands are analysed for (1) alumina, (2) free silica, (3) loss on ignition. Alumina represents strength and wearing qualities, free silica openness or porosity, and loss on ignition the moisture and vegetable matter. Lime and magnesia are usually present in such small quantities that they may be disregarded. Sands, however, cannot solely be judged on chemical analyses, since one having the proportions of constituents considered suitable may still be without the grit and consistency necessary for moulding.

Green-Sand.—There are two distinct methods of sand moulding, namely, green-sand moulding and dry-sand moulding. Each method requires a sand possessing special properties. Green-sand must be of a light and soft earthy nature, velvety and fine in texture, and when gripped tightly

with the hand should retain the impression so given to it. Such a sand usually carries a large percentage of water with safety. It is rich in organic matter, and for this reason it is precluded from being baked, or dried in the stove in the form of dry-sand moulds. Heat renders it useless for "dry-sand" moulding purposes, hence its name "green-sand."

Dry-Sand.—The term employed here denotes a sand free from water or moisture of any kind. However, before we can get the mould in its final state, that is, after it has been dried in the stove, we must make this same mould with sand of the consistency of green-sand. Here the term "consistency" has a limited meaning, for dry-sand moulds are composed of rock-sand as a basis. This rock-sand is derived from the sandstone of the geologist. In sandstone the grains of sand are bound together by some cementing material, and it is the nature of this cementing material which determines its value for dry-sand moulding, enabling the mould to withstand the action of heat. Often a sandstone in a rotten state, useless for building purposes, is all the better for the foundry; while in other places the sandstone blasted from the quarries, and milled, proves a stronger sand for dry-sand moulding than that found in a comparatively broken and disintegrated condition.

We thus see that the chief characteristics which divide green-sand from dry-sand, and *vice versa*, are :—(1) Green-sand is earthy and comparatively full of organic matter, which assists venting, but, as a natural consequence, is only nominally refractory, and not at all suited to resist much heat. (2) Dry-sand is refractory, glutinous, and plastic, and so tends to prevent venting, and makes drying an absolute necessity, thereby making the work more costly. This additional cost, however, is compensated for by superior castings, and in many cases dry-sand castings are not inferior to those that are done in loam.

Our next duty is to discuss the compounding or mixing of the respective facing sands for these two divisions of sand moulding. On this point moulders have many conservatisms, judging the nature of sands by their colour, and although often excelling themselves in this respect, quite forget that

the fundamental properties of moulding sands are plasticity for binding and porosity for venting.

Light Green-Sand Facing Sand.—In mixing sand for light work, whether for bench, tub, or floor, rock-sand ought to be avoided, its grittiness of texture making it badly suited for this class of work. Light work, not being exposed to an excessive heat from the metal, does well with an earthy and velvety sand. Therefore, the sand used should be able to pass with comparative ease through a No. 12 or 16-mesh sieve at a dampness suitable for moulding. Where Belfast and London sands are procurable, these in equal parts make a capital mixture with the requisite percentage of coal-dust. Belfast sand by itself produces the finest impression, with work of superior architectural design, and is an excellent sand for light brass moulding in general. The proportions between new sand and old, or black-sand, must be left to individual circumstances, as also must the proportion of coal-dust in the batch. This latter ingredient must be controlled by the conditions of the new and old sands, as well as by the lightness or heaviness of the metal.

The standard of consistency can only be gauged by practice, and even one uniform standard of consistency will not suit all kinds of work, for occasionally work with peculiarities of its own have to be faced and mastered. For instance, in moulding a small-tooth wheel, using as a pattern an old casting in which there are many irregularities, such as broken and twisted, worn and swollen teeth, irrespective of other parts of the wheel, the facing sand for the teeth should be made unusually damp and a little flour added to toughen and give fibre to the sand, so as to prevent the teeth from wasting themselves in the operation of drawing the pattern from the sand. In ramming this extra damp sand, more than usual care must be taken while tucking up the teeth, so as to prevent clogging, and when the mould is finished it must be at least skin dried before casting.

Heavy and Medium Green-Sand Facing Sand.—It is not in keeping with good practice to have sands for both classes in an ordinary jobbing shop. Jobbing shops having heavy and medium green-sand work, generally keep as their standard a

medium mixture, and when a lighter or heavier grade of sand is required, weaken or strengthen it accordingly; the terms "light" and "heavy" indicating section of metal the jobs contain. For this standard medium mixture we take, say, three parts of new sand to one of coal-dust. The new sand may be reckoned as equal parts of London, Belfast, and Scotch rock or freestone sand, or sands of similar grit. These three sands give a very desirable gradation of the essential properties dividing green-sand from dry-sand, the London sand being intermediate between the other two, and it would be difficult to find a more useful combination of sands for green-sand moulding in general. These again are reduced by black-sand according to our habits of practice. The foregoing is at best an approximation, because sands vary so much both chemically and physically that nothing but a mere rule-of-thumb system of mixing facing sands has as yet found its way into foundry practice.

Having dealt briefly with medium sand, we next consider sand most suitable for heavy castings, or sand having unusually thick metal to contend with. It is worthy of note that a sand for such thicknesses of metal should be specifically lighter than that required for light castings, and for general purposes also. Now, suppose we take as a basis the medium mixture as made up, we should then be perfectly safe, for the main feature of sand for heavy metal green-sand moulding is porosity within certain limits so as to secure contour and normal "graininess" of surface, factors of the utmost importance in preventing scabbing. This class of work is usually open, with easy access to all parts, and as a matter of fact there is no difficulty, if it be desired, in rubbing up such moulds with plumbago, and so turning out a very superior heavy green-sand casting. - Indeed, it is no uncommon sight to see green-sand work, which has been thus treated, with an appearance not inferior to some dry-sand castings. So much has this been the case in the author's experience, that he has had the question put as to whether such and such were green or dry-sand castings; and this, indeed, without any "skin drying." Hence, to increase this porosity, we weaken the sand by the addition of "sharp" or "river" sand, and increase the coal-dust

considerably, the last substance of all the materials known to the writer being, when discriminately used, the best guarantee against scabbing. This sand answers its purpose best on side and bottom surfaces, but is not recommended for tops.

However, it must be strictly observed that in "weakening" green-sand facing sand by "sharp-sand" we are in no way reducing its refractoriness, but rather increasing it. Nevertheless, "weakening" by a large proportion of Belfast or such organic sand would, owing to the continuous flow of metal such as we have through the arms of a large spur wheel, in a "green-sand" mould be liable to lead to scabbing. Belfast sand, not having the refractoriness common to most moulding sands, would give way under the flow of the molten metal at the time of pouring; here again we see the necessity for limiting the use of this sand to light castings.

To return more definitely to the function of coal-dust and sharp-sand as preventives for scabbing in heavy green-sand castings, sharp-sand increases porosity, while coal-dust absorbs alumina and clayey water, thus reducing the generation of steam and expediting venting. The only other advice the writer can give from practical experience is to work the sand as dry as is compatible with safety of moulding.

One very important feature of heavy green-sand moulding is to keep the sand from baking. Therefore, it is necessary to reduce to their lowest limits those substances which increase plasticity, such as alumina, clayey material of any kind, and water. Sand that has to be subjected to the heat of fluid metal must get rid of its moisture first, otherwise the pores of the sand and vents of the mould become overloaded with steam instead of gas, and much mischief may result. To sum up, the factors for success in heavy green-sand moulding are porosity, consistency, and intelligence in ramming, venting and finishing.

Milling of Green-Sand Facing Sand.—Some consider this to be of extreme value; in the author's opinion it has its limits. A sand that is milled must at all times be more dense, and as a consequence its venting power is diminished. But in the case of a sand for moulding teeth, and other fine castings of elaborate design, milling is an-advantage, and assuming

the teeth, as in spur wheels, to be in the vertical position while casting, milled sand has the double advantage of adding strength to the teeth while drawing the pattern, and giving better contour to the teeth when moulded, which result in a superior casting.

Sand for gear wheels is greatly improved by adding a small percentage of core-gum to the batch; core-gum is not less than three times as strong as flour, and when baked by drying the teeth become as good, if not superior, to a dry-sand spur wheel casting. Teeth made from this sand can stand any amount of drying, and may be made as hard as a bone without fear of injuring them in any way. They are also entirely free from swelling, an evil which frequently happens to green-sand moulded teeth without drying.

Coal-Dust.—This is an adjunct in the mixing of green-sand facing sand, which is likely at all times to play an important part in green-sand moulding. Its normal function is to assist in skinning this class of work; abnormally it hardens the metal and for this reason is frequently resorted to when a hard skin is imperative. But its use must not be overdone, or we run much risk of pock-pitting the "skin," and thus making a faulty casting.

In selecting suitable coal to grind into dust, it is of the utmost importance to know the proper quality, as a coal of a luminous standard carries too much pitchy or tarry substances and is sure to produce bad effects, which will show themselves on the surface of the casting in a somewhat honeycombed design, which, although of trifling depth, is very objectionable indeed. The most suitable coal to mill or grind for coal-dust is that of the non-bituminous order. This is a coal which does not give much flame, but is very rich in carbon, sometimes containing about 90 per cent. of that element.

Founders have many uncertainties to contend with in their daily routine, and doubtless to this is due the cry for analytical scrutiny of materials. The fixing of a standard quality in coal-dust, or a knowledge of its real value, for the purpose intended, would be of great benefit in the production of green-sand castings, where it has to play such an important

part. Genuine coal-dust from suitable coal, which was at one time regarded as waste, is now treated for the production of by-products so as to satisfy the craving for economy in some other industry. Hence, what comes on the market as "coal-dust for foundries" is often nothing short of rubbish swept from the bottom of coal mines and such like. This sort of coal-dust is largely composed of clay and other non-carbonaceous matter. Therefore, if good work, as it relates to this material, is to be maintained, then the eye of the chemist on this department is of considerable importance to the founder of green-sand castings, both light and heavy. All foundries which grind their own coal-dust are in the long run supplied in the safest and most economical manner. Of course the same may be said of blacking, but we have never found it so in our experience.

Black-Sand.—This sand is at all times of doubtful composition, but wherever possible it should be taken from a floor exclusively kept for the production of green-sand castings. As a case in point, take that of a floor in a jobbing foundry casting green and dry-sand work alternately. On changing from green-sand to dry-sand, the addition of a large amount of clay water in what was formerly green-sand has become absolutely necessary. This, together with the dry-sand facing in the moulding of a job under such conditions, as also the drying of the job in the floor, makes the destruction of carbon formerly contained in this green-sand floor to a greater or less extent a moral certainty. The carbon it contained previously has been replaced by alumina, etc. Consequently no good result could attend the casting of a mould made with such sand unless it had been dried.

It might be said that clay destroys the effect of carbon, and coal-dust can in turn destroy the effect of clay. This to a certain extent is true, but at the same time wherever dry-sand and green-sand work is intermittent on the same floor space, the green-sand work suffers most, and before a green-sand floor thus treated can return to its normal condition time and special treatment must be resorted to, clearly showing that much care should be exercised in selecting black-sand from the floor for the purpose of mixing green-sand facing sands,



light, medium, and heavy, but most especially for work of the finer type of castings.

Black-sand for dry-sand work has but little in common with black-sand for green-sand work. In a word, the relationship is as far removed as the one facing sand is from the other.

Dry-Sand Facing Sand.—The essential property, as already mentioned, is plasticity together with pile or grit, and every sand to be used for dry-sand moulding must be satisfactory in this respect. A sand of this description is at once refractory and capable of withstanding all drying or baking common to dry-sand moulding. Moulds made from such a sand and rightly rammed produce castings free from swollen or objectionable protrusions of any kind, even where excessive static pressure is exerted.

Where circumstances are unfavourable for obtaining a glutinous rock-sand, it becomes a matter of compounding or mixing with some sort of clay wash, glucose, or such like. These in some way make up for natural poverty of cohesiveness and plasticity of some rock-sands.

Although rock-sand may be the basis of all dry-sand, it is not absolutely necessary that facing sand should be made from it entirely. Some localities have easier access to river-sand than they have to rock-sand, and in this way they substitute loam for the mixing of dry-sand with good effect. Wherever the former can be got no inconvenience from any point of view need be experienced, as with this material for mixing with the ordinary black-sand we secure the better article for dry-sand moulding. Loam ground or milled from river-sand, with the amount of clay added, which is at all times a variable quantity, should be within the reach of the man mixing and milling, wherever such is in operation.

As to the economical view of the question we say, in a word, that it is really bound up in the process of milling. It is surprising that in this advanced age of foundry equipment there are many foundries doing a considerable business in dry-sand moulding, that are still working away under the old condition of things as they were in operation *fifty* years ago. In this they are awkwardly working by tramping with the feet, hashing, and laboriously mixing that which, if milled,

could be done in an infinitesimally short space of time when compared with the antiquated practice of mixing sand and loam in the foundry. While there may be strictures applicable to the milling of green-sand facing sand, practically there can be none with dry-sand. Sand that is milled is better prepared for ramming, finishing, venting, and is always superior to hand-mixed sand for chapletting, and in every way makes a stronger mould, a feature of much importance in dry-sand.

Again, there is much first-class dry-sand facing, made from loam-work "offal," secured from the emptying of loam castings, and with a supply of this material, and without rock-sand altogether, one need have no dread of getting an inferior sand. Of course, this by itself is generally too strong, therefore it becomes a matter for the man in charge to direct the proportions between black-sand and this loam-offal. The utilisation of this material is probably one of the most positive foundry economies with which we come in contact every day. For where no milling of sand is done this refuse or offal is usually foolishly consigned to the "dirt-heap."

It is astonishing how some very poor sands are improved by milling, but it is a fact that whether mineral or vegetable, everything rolled, pounded, hammered, or kneaded, is toughened thereby. Thus it is that sand passing under the rollers in milling becomes so improved that it more than compensates in a comparatively short time for the expense of purchasing a mill.

Two or three shovelfuls of rock-sand added to a barrowful of good black-sand, and milled, will make an average facing sand; but without milling, the rock-sand here would require to be more than doubled. Where no rock-sand is used, two shovelfuls of loam is ample for a similar quantity of black-sand. The loam for this sand is very strong and stiff, and is made from river or iron gravelly sands passed through a $\frac{3}{8}$ -in. mesh riddle. In some cases those sands have abundance of clay in themselves, others require to be helped in this matter, but in any case the loam should be gritty and plastic.

In summarising these details of moulding sands and facing

sands for iron founding, they may after all be at best ambiguous, especially when viewed from a theoretical standpoint alone, for practice has but poorly rewarded labour expended in theory. It must be admitted that chemical analyses have not completely solved the problem of determining what sands are suitable for moulding. Many sands from the chief centres of supply in the United Kingdom of the same geological age and possessing very similar composition behave quite differently in the foundry.

The foregoing shows that experience born of long and constant observation is of the greatest importance in educating a man in the selecting of suitable moulding sands and compounding or mixing them for facing sands to supply the variety of needs in the different branches and grades of iron founding, or other branches of founding.

“Grip” and “break” are the physical features or tests which are used in practice. And to the man who understands his business properly in this respect it has been said that his sense of touch is of more value than his sense of sight. It is simply a physical test that fixes the dividing line between green-sand and dry-sand moulding sands. Green-sand, as has been said before, must have a velvety grip, and be capable of receiving considerable water without showing much inclination to become plastic. Dry-sand must be strong and gritty, within certain limits, and highly refractory—the exact opposite to green-sand—and on receiving an excess of water should become plastic. These two sands in their respective natures are the sands practically from which all facing sands are compounded or mixed, for the many varieties of work in either green or dry-sand moulding.

LOCATION OF IMPURITIES

How annoying in many instances is a want of knowing how to deal with dirt, sillage, kish, or any other substance that may be called in this sense an impurity, goes without saying, and how doubly annoying it becomes when it is found that if the casting in question had been cast in the right position—or shall we say “face down?”—all would have been well!

I daresay, on reflection, something like the above is the experience of most moulders who have had much to do in casting machine, tool, or polished work. The result of an incorrect method of casting is every now and then manifested by some unforeseen failure, which is frequently attributed to dirty iron. But not infrequently these losses are due to the fact that the instructions given to the foundry regarding those parts to be polished are insufficient to enable the moulder to locate the impurities common to cast iron so that they shall have no harmful effect.

When a responsible foundryman views a pattern for the first time, and if no special instructions be given as to casting,

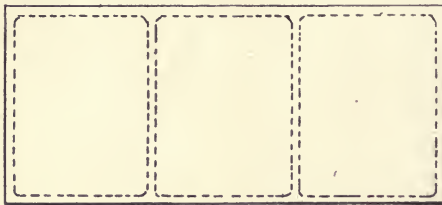

FIG. 13.



FIG. 14.

his first and last concern is the quickest way to mould it, and should everything to outward appearance turn out well he has every cause to be satisfied with the result; but, alas! by the process of machining it may turn out a failure.

In Fig. 13 we have a polished surface, and its sides are machined right round also. The quickest way to mould this casting, assuming it to be a complete pattern, is by top and bottom boxes, or, if preferable, call them cope and drag; and in the absence of specified instructions, the chances are that not one in a hundred moulders would ever think of casting it in any other position than that of the plain face upwards. Therefore, assuming this to be the case, the likelihood of the face turning out as desired, that is to say, perfectly clean, would as likely as not be *nil* or at best it would be speckled, and in some cases hopelessly lost; but with "face down," all this disappears, and under normal conditions, as shown at Fig. 14, that which is deleterious to polished metal will float up amongst the ribs or stays of

the casting and become harmlessly incorporated amongst the unpolished parts.

True, this way of moulding considerably increases the cost of production ; but where a clean-faced casting is paramount to all other considerations, there is no choice but to adopt it. And lastly, on this job it will be obvious that no matter whether the plain face or ribs be cast uppermost, the sides always remain in the vertical position, considered by many the ideal position to secure the cleanest of metal castings.

Fig. 15 shows a cylindrical section, having a small projection *A* on the top side, which forms a receptacle for those impurities which rise to the highest part of the casting at time of pouring ; and wherever part of a column, pipe, or such like, cast in the horizontal position, has to be turned, a receptacle thus formed to locate dirt outside the casting proper will more than likely produce a good casting, which otherwise might have been a failure. But were such cast on end, no such thing would be necessary, because its place would be taken by the "sinking head" which is necessary in the pouring of all vertical castings, and whose capacity for dirt and feeding purposes is varied according to circumstances.

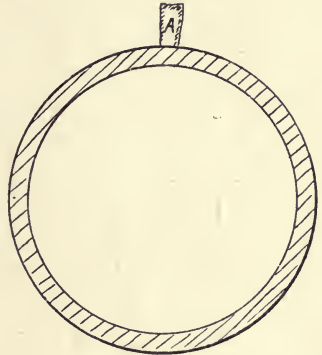

FIG. 15.

Instances of this class of work could be multiplied by the score, but the examples given should establish a principle in foundry practice, that the location of impurities should be confined to the unpolished parts of castings, etc., and if need be by the aid of suitable projections that can be removed by hammer and chisel or machine, as the case may be.

Thus far, so good, for the foundry ; but what of the pattern shop's responsibility in those matters ? And here let me say that I make no specific charge against the pattern shop, further than by saying that there is a great want of a recognised principle in giving instructions in foundry work. In ordinary

disciplined engineering works, all instructions necessary are attached to drawings, and where blue prints are much in evidence, we usually find the following phrase:—"Where marked red to be machined," or some such instruction, but the very place where this is most necessary, namely, the foundry, we usually find nothing, and if the person in charge does not make some enquiry before bedding or ramming up, much of the work belonging to many of our jobbing foundries would be lost through being moulded and cast in the wrong position. Some engineers and founders have a very excellent style of painting their patterns. The general body may be any colour, but is usually a dark red, but no matter what the body may be, cored parts are painted black, and those parts of the casting to be finished always shine out with a bright red colour, indicating, of course, that more than ordinary care for a clean metal face is necessary. The value of these practices must be obvious, since it is a fact that moulders as a class of mechanics know nothing of detail work, as a rule, further than their pattern or model gives, combined with such information their foreman may have to give them. Hence the practice of varying the colours in painting patterns, wherever observed, must have its advantages, inasmuch as it not infrequently happens that the loss to the engineer, by the time spent on a bad casting due to dirt, is as great, nay, sometimes greater, than the loss is to the founder, and which, probably, might have been no loss to either, if position for *location* of impurities had been attended to. Evidently the foregoing can only refer to standard patterns, but while this is so, the use of a good blue or red pencil stating in plain English the parts to be faced or polished, would in many instances save castings from being consigned to the scrap heap.

It must also be remembered that impure, dirty or speckled surfaces may be due to other causes than those considered in this chapter, such as "clubby" or disproportionate metal, but these will be dealt with later in the chapter on "Defects in Cast-Iron Castings."

CORE GUM

It is about twenty-five years since the writer first used core gum in core-making, and since that time it has become very popular in foundry practice. Previously to its introduction there were many devices for binding or strengthening the sand in core-making, such as clay water, salt water, sour beer, etc., and in very small cores it was no uncommon thing in some districts to see potatoes pounded in sea-sand to give cohesion to the sand and at the same time porosity for venting. Since the introduction of core gum these former practices have largely if not altogether disappeared. The indiscriminate use of core gum by many moulders has, however, been the cause of a good deal of bad work. Sometimes it has been used to such an extent as to make the core somewhat of the nature of an ordinary brick, thus destroying all porosity. A core made from such a mixture as here described can have only one result, namely, a bad casting.

The cores of a green-sand mould that is "cored," entirely closed and has no current of air passing through, readily absorb water from the moist atmosphere of the mould. But should the cores in such a mould be made with sea-sand and core gum, this danger is greatly minimised; this is one of the greatest recommendations in its favour. If a core made with sand heavily laden with plastic matter becomes damp through lying in the mould, it is sure to blow. This blowing will be more mischievous with a core in the horizontal position than it would be with one in the vertical position. It would appear that there is great lack of knowledge regarding the use of core gum. Even those who seek to trade in it do not seem to have acquired sufficient knowledge as to its real nature in so far as foundry work is concerned. Trade circulars advise the user to dissolve it in hot water, which cannot be properly done; and were one to boil it, the undissolved parts, which float about the surface of the liquid, would simply become harder. Some may say that this is of small importance, as it can be strained through a sieve; but why have this loss at all, when by proper care there need be none of it? The speediest and by far the best way to dissolve core gum is by

the aid of cold water. Thus—take 2 lbs. or any workable quantity of core gum, put it into a suitable dish, then add a little cold water, taking care to add no more water than the gum is capable of absorbing. After stirring it well, and when it has scarcely reached the pasty condition, add a little more cold water and stir again; again beat it well with a stick and add a little more water, continuing to stir. It will now have reached a semi-fluid condition. Transfer the contents as mixed to an ordinary 2-gallon bucket and fill it up with water. It will thus be seen that there is 1 lb. of core gum per gallon of water, though this is not given as a fixed rule. In mixing sea-sand it is better if the sand is dry, then all that is required in mixing such sand for cores is to apply this gum water to bring it to the desired consistency.

Cores made with such sand must belong to the lighter class of castings, as this sand is insufficient to withstand the strain and the rush and flow of a heavy body of metal. While this sand is highly favoured in giving completeness of outline, it is altogether unsuitable for rubbing or carding, and were one to attempt to do so, such a core would collapse, its strength being entirely on the surface. Of course these remarks on sea-sand only apply to sands that may be said to be absolutely free from clay or plastic matter. All the same a little clay at times for certain cores is an advantage.

Should certain conditions make a dry method of mixing preferable, add about 2 lbs. of core gum to four ordinary buckets of dry sand; mix thoroughly together, and add water to bring it to the desired consistency. Dry black-sand, sieved, will do as well as sea-sand; but as it contains an amount of plastic matter, less gum will be needed, the amount being determined by experience.

Gum water, with a little plumbago, is very serviceable in washing a mould after it has been sleeked, and is also suitable for repainting a mould that has been burned in drying. The old practice of re-blackwashing is almost sure to result in scaling to such an extent as to make bad work. By using this wash in the manner described it penetrates through the burned surface, and almost restores the mould to its normal condition. The writer has dusted core gum on green-sand

work in order to bring out better effects. This is of greatest advantage about the gates of the mould, these parts being most exposed to the burning rush of the metal. The advantage of this is always more apparent the longer the gum lies upon the mould before being cast. The gum readily adheres to a greensand mould that is damp on the surface, and through atmospheric influences the mould is thus improved, certain weathers being more favourable than others. In brass work it is not so serviceable as in iron, its tendency being to give a rougher skin to the casting, in consequence of which the brass finisher has more trouble in tooling the castings, blunting his tool oftener than would be the case with a brass casting skinned with pea-meal.

BLOWHOLES IN CASTINGS

In these days of superior workmanship we still hear much of the so-called blowholes in castings. Recent inventions in the way of fluxes have done but little, if anything, to remove these defects, although one would have thought when these fluxes were being introduced into the trade that a panacea for a very large percentage of the moulder's troubles had been found. It does seem strange that, should a casting have ever so small a hole showing itself on a finished part, the moulder has to bear all the blame, whereas it may be one of those faults that more properly belongs to the iron smelter; or, if such defects appear in a more intensified form, the engineer or the one responsible for designing the casting is responsible. This intensified form of "blowhole" is usually a "draw" through disproportionate metal, and 95 per cent. of what are termed in finished work "blowholes" are incorrectly so called, as they are entirely due to shrinkage.

I do not say that modern fluxes can in no way improve the founder's position; but while these may be useful in eliminating impurities and giving increased fluidity, they cannot make up for the loss of density due to disproportionate thicknesses.

It matters not how much blowing a crude pig may show in fracture, this same product must be returned in the form of first-class polished work, and the fact of modern fluxes being

so much to the front clearly indicates that much is at fault with pig metal, for which the moulder cannot be held responsible, or that the founder is at fault in mixing his metals.

Thus far it will be seen that what are popularly known as blowholes in castings are due to unsuitable pig metal or to faulty design. But as it has been in the past, so in the future the moulder will undoubtedly be held responsible for all defective castings caused by "shrinkholes," whether due to shrinkage or to gases.

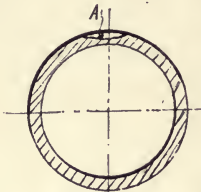

FIG. 16.

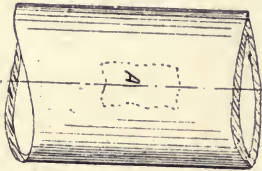

FIG. 17.

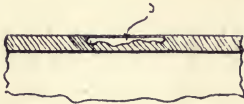

FIG. 18.

Once understood, it will not be difficult to remember that a blowhole—that is, a hole formed in a casting through the action of an air-bubble—is always of a clear colour, and has a hard or chilled surface. A shrinkhole is generally of a bluish colour, its interior being rugged, and at times taking the form of a rough spider's web. The contrast is very decided, and no one, therefore, need be mistaken. No holes of the latter description are to be found in proportionate metal.

In Figs. 16, 17 and 18 at *A* is seen a very common form of blowhole, usually styled in foundry parlance a "blister." This form of blowhole

is very common on pipes that are cast in green-sand in the horizontal position, and is undoubtedly a moulder's error. In this matter, however, opinion differs very much. Some maintain that it is caused by too hard ramming of the top part or flask, while others maintain that it is caused by the core being too hard, the latter being the true solution, in the writer's opinion. Many years ago I happened to be a working journeyman in a shop doing a large trade in green-sand column and pipe work. Along with others I was at times troubled with "blistering" on the top side of these

castings, so much so at times that in a 9-ft. length of pipe at a distance of about 2 ft. from the flange of both ends one could, after breaking the skin, which was no thicker than ordinary silk paper, easily fit in the side of one's finger in several parts of the space mentioned. These blisters are always hidden until by accident or otherwise they are broken. The simplest way to find them is by rubbing the head of a fettler's hammer across the top side of the casting, when, immediately the hammer passes across them, they will respond by a slight whistling sound. As a practical moulder I have never found too hard ramming of green-sand pipes tend to cause blistering, neither do I regard the use of the vent wire in such work a necessity. The hardest ramming of sand in this class of work leaves sufficient porosity to admit easy exit of the gases, but a top part that has been rammed up with too wet sand would never retain its metal. The chances are that immediately it was cast it would emit its metal with such a spluttering that no hope of saving it would be possible. A core that is too hard may be so from two causes—either from too hard ramming, or from the sand being too wet. It may be asked what guidance there is to determine with accuracy what consistency is required. To this, I say, there is but little, as it is simply a matter of continued practice and close observation as to results. A sand that gives off a perceptible amount of water, or, as it were, sweats the core-box in making the core, is certainly not good. Cores made from such sand are dense, difficult to vent, and troublesome to the fettler in coring the casting. A defective loam core may be due to several causes. Two of these may be mentioned—viz., too strong loam, by this I mean a predominance of clay or plastic matter (such substance closing up the most porous of loams); and secondly, the working of the last coat of loam to the extent of bringing up a glazed surface. In these two classes of cores (especially in horizontal pipe casting) is to be found that which should be avoided, viz., excess of density. But wherever it exists, if the moulder, before blackwashing such cores would simply draw his card across the glazed surface and destroy such density, he need have little fear of the result. There is

no necessity for carding the whole core; as the roughing of the top side will ensure a free exit of the gases contained in the core. To those who may have doubts upon this matter I should like to draw their attention to the contrast of a dry-sand and loam core as against a green-sand one. In using a green-sand core, should the core "scab" the unanimous opinion would be that too hard ramming was the cause. This is somewhat similar to what takes place with a dry-sand or loam core that is too hard and glazed on the surface, with this difference—that we get the blister on the latter, while we have the scab on the former, the blister being due to the fact that the surface of the core has remained intact throughout the period of fluidity, and thus has prevented the escape of gases. But were the surface of the core to break away (a thing that has never happened in my experience) there would be a scab in the place of a "blister," thus clearly showing that blisters or blowholes in such castings are caused by laxity in venting.

BURNING OF CASTINGS

The process of "burning" means the renewal of a defective part of a casting by pouring fluid metal on to it until the defective part has become fluid, and then filling up the space with fluid metal. Or, the ends of two separate pieces may be joined together by pouring metal right down through any broken casting, as shown in Figs. 19 and 20, and thus uniting the two ends into one. Care must be taken to give plenty of metal for chipping, turning or finishing. If this be attended to as directed, and the burned part be finished an inch or two outside the new metal, it will be almost impossible to detect where the joining of the old and new metal begins.

"Burning" is not done well by quite a number who attempt it, and doubtless this in a measure accounts for the prejudice which many engineers have against it. Many attempt to perform this operation without clearly understanding its essentials. Thus no one can "burn" who does not take due account of the effects of the expansion and contraction of metals. It is true that this is not a branch of

the trade that is accessible to the ordinary moulder in the sense that other foundry practice is ; and it is to those who are so unfortunately situated, and desire to know something of the subject, that this chapter will be of most value.

"Burning Cold."—It is an easy matter if we simply look upon the part to be burned as a hole in a casting, and a pouring of metal on such a part until it becomes fusible, and then the filling up of the hole to our satisfaction with fluid metal. But if nothing be done to expand this part of the casting previously to burning, and if it be of cylindrical section, then there is no chance whatever of such an attempt at burning being a success, in so far as its capabilities of withstanding a static pressure test of any kind is concerned.

By the foregoing it is not to be inferred that to "burn" without heating castings, in every case, to a dull red heat is



FIG. 19.



FIG. 20.

an impossibility. All castings or parts of castings that may be said to possess regular shrinkage, such as the one illustrated in Fig. 19, are quite safe, and have no need of previous heating. In Figs. 19 and 20 it will be seen that in burning right down through this broken shaft or bar, a certain amount of expansion must take place. It will also be seen that there is nothing to interrupt its expansion, and, since this is so, there is likewise no restraint in its contraction. Had such an article been bound, as the spokes of a wheel are bound to its boss and the rim, such a method of burning, as shown here, would prove an absolute failure.

Fig. 21 is another example of what can be done with perfect safety without previously heating the casting, and if such a flange be attached to a pipe, or any other cylindrical casting, and the flange be broken not too near the fillet of the body attached to the flange, there is no danger of the casting cracking from expansion by the process of burning without previous heating. It is better in such cases as this to make

sure that the burn will all be of new metal, and sufficiently far into the flange to admit of the bolt holes being drilled entirely through the new metal, because, should it happen that the drill in boring the holes in the flange came in contact with the chilled metal which inevitably joins the old and the new, the chances are that the casting would run much risk of being lost altogether through the drill not having the power to get through the chilled metal in question.

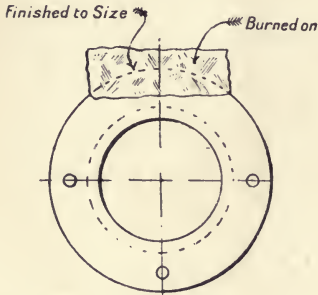

FIG. 21.

What is stated here as applying to the burning of "cold castings," applies with safety to any terminal or other parts

of a casting that are in every way free to expand and contract without developing undue strains in any direction.

Having shown in a practical way those classes of castings which can be burned with safety without heating we will now give one or two examples where heating previously to burning becomes an absolute necessity.

Heating.—In the first place take a casting with a cylindrical body, which may either be cylinder, pipe, valve, plunger barrel, or square hollow section of any kind, and with no internal attachments cast on. Now, with any of these castings having a defective part, there is no difficulty in burning such castings to withstand as much pressure, if not more, than the soundest part of the entire casting, provided it be gone about in a right way.

The *modus operandi* should be as follows:—Place the casting on the dead level with the part intended to be "burned." Secure the same by ramming properly with sand, or otherwise. Next surround the casting or as much of it as may be necessary, by a perforated brick wall, or improvised oven sufficiently high to enable the top to be covered with plates and so form a temporary furnace. Then, build a fire and light it, and when the smoke has almost exhausted itself, roof across with the plate or plates mentioned, and when

the casting has reached a dull-red-heat apply the ladle with its metal contents and "burn." Every operation, wherever possible should begin and end with one ladle of metal, and this is specially so when a crane ladle has to be resorted to. On the burning being completed it should instantly be covered over with charcoal or blacking. This secures it from atmospheric chilling, and as a consequence the metal is softened, thus making it easy for chipping and filing. With the "burn" covered over with blacking the plates are again thrown over this temporary furnace, and the whole affair is allowed to cool as if it were an annealing oven. With such treatment as above mentioned, no one need fear the result, as I have never seen it fail to give the greatest satisfaction.

But whether heated or cold, castings are in no way weakened by burning if in the process of burning they have been allowed to expand and contract in the manner previously referred to.

Brass may be, and is, burned cold; steel is similarly treated; but in these cases the ductility or malleability of these metals admits of "pinning," and so saves the castings from becoming "wasters." Pinning thus with cast iron is an impossibility because of its hard and unyielding nature.

VENTING

All moulders who desire to master the intricacies of their trade should very carefully study the subject of venting. If venting be done imperfectly, blowing, scabbing, or both together are likely to occur, and that which should have been a good casting turns out a scrap, and hence the importance of venting properly and giving means of easy exit to the gases.

A slight digression may be made here on the question of the finishing of a mould as it relates to venting, and what is said at present specially applies to heavy green-sand work. The principle, however, might with advantage be applied to all branches of moulding. The fault common to jobbing moulders in finishing is the desire to polish the surface until the grain of the sand which composes the mould becomes almost imperceptible. Wherever such unnecessary work is performed the danger of scabbing is greatly increased, even although the

vent wire may have been applied with intelligence. The reason of this to practical men is obvious, as such glossy polishing destroys to a great extent the porosity of the surface, and the metal in consequence cannot come to rest in contact with the surface of the mould, until the polished face breaks away to allow the escape of steam and other gases, thus causing a scab on the casting. Therefore it will be observed that discriminate venting, form and efficiency should be the guiding principles in finishing a mould, leaving as much polishing as is necessary to come after blackening or black-washing.

Fig. 22 will serve to show what is required in general practice. In looking at the relative position of the vents, *viz.*, the bottom *A*, the top *C*, and the sides *B*, I believe it is within the mark to say that the danger of scabbing on the bottom is three times greater than it is likely to be on the sides, and the danger from scabbing on the top side is almost *nil*.

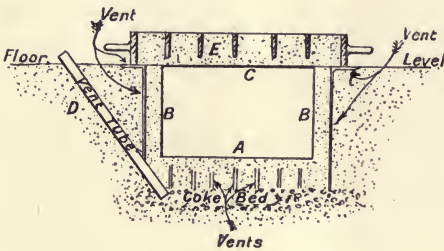

FIG. 22.

In the foregoing I have merely shown

effect; but what of the cause? The only reason I can assign for it is the natural tendency which gas has to rise upwards, and were it not for the vents that are seen on the bottom of the mould (Fig. 22), nothing could prevent such a mould from producing a badly scabbed casting.

Having made the principle of venting the bottom presumably clear, it leaves one but little to say concerning the side vents. It will be noticed that these conduct the gases through the joint of the mould, but should they fail to make their escape as mentioned, there is no reason to doubt that were the side vents connected to the coke bed, as shown in Fig. 22, the safety from scabbing in such a job is equally secured. There is no fixed rule that all vents should pass straight upwards in the vertical position, the very opposite is the case in many jobs, as, wherever the coke bed is necessary in the venting of the

mould, all gases must pass downwards into the coke bed before making their way through the tube *D*, as shown on the figure. Still, as a principle, let them off as quickly and freely as possible.

In the top part *E*, I have already stated that the danger from scabbing is almost *nil*. This is attributable to the fact that the gases make their exit without coming into touch with the metal. It will require no great stretch of imagination to see that when the mould is filled up to the top with metal, the gases in the top-part pass off quite uninterruptedly. This is entirely the opposite of what takes place at the bottom, as we find these seeking to make their way through the surface of the mould, and but for good and direct venting to the coke bed, as seen at Fig. 22, and a speedy covering of the surface of the mould while casting, the gases would obtain the mastery with disastrous results.

It is a disputed point with many moulders as to whether it is necessary to use the vent wire for the top part or not. Practically, I have always discarded it, as I believe all moulding sands are sufficiently porous to make such venting unnecessary, and that metal will lie in contact with any flat top-part of a mould, however hard rammed in green-sand, or imperfectly dried in dry-sand. The only thing that can happen with the latter is the extra tenacity with which the sand clings to the casting, but it in no way seriously affects it. This adhesion is caused through the generation of steam, which more or less comes in contact with the casting the moment the mould is filled. Again, I consider a top-part that is not vented to be stronger on that account, and has less tendency to be "drawn down," as the gases that generate at time of casting are better held, inasmuch as there are no vents in the top whereby they would be able to escape more readily. Thus it will be seen that with the greater pressure on the flat roof, the top-part is thereby carried up; consequently the danger from "drawing down" is greatly minimised. But I must not be misunderstood concerning the difference between flat top-parts, and those that have cores or projections attached that have been rammed from pattern. Wherever there are projections, "pockets," or anything that is

rammed up in a top-part and projects from the surface, such must be vented and with the greatest care.

THE USE OF THE RISER IN CASTING

“Riser” is the name given to the overflow of metal indicating when a mould is filled at the time of casting. Risers are necessary for a three-fold purpose, first, as already stated, to show when a mould is full; second, to relieve the highest part of a mould of the dirty metal which invariably makes for the highest part, and third, for feeding purposes. They may likewise assist in checking the pressure and velocity of the metal at the time of pouring—two very important matters for which a moulder must intelligently provide.

In the first place, it is necessary in casting for one to have an idea as to the most suitable moment for checking the ladle. It is no uncommon mistake to see a mould unduly strained for want of precision in this matter.

The number of risers in a job should always be fixed and proportioned as far as practicable in accordance with the size of the pouring gates. Care should be taken to have the risers at all times somewhat less in area than that of the pouring gates, otherwise, the force of compression necessary for the casting will be insufficient. If we consider a job being cast, the risers of which have twice the area of the pouring gates, and the metal is somewhat duller than desirable, the casting is sure to suffer to some extent from want of compression. This is due to the metal having failed to rise in the riser basins owing to the extra area of the risers, thus diminishing the fluid pressure.

No doubt much work is cast without the aid of risers, but it is mostly of an architectural order. Even in this class of work some prefer what is called a “blow off” about the corners or terminus of the mould, which is the means of brightening up what would otherwise be a dull part of the casting; but as this may not be more than a twentieth of the pouring gate, it is not necessary to treat it after the manner of a riser. This class of work is always preferred with as little broken skin as possible, and as it must be cast at a high temperature, risers are not a great necessity. The principle of moulding here

adopted is what is known as the "turn over" with top and bottom boxes. These being tightly clamped, with ordinary care there is no real danger from straining,¹ no matter at what speed the mould may be filled.

The placing of a riser on the highest part, must at all times be observed, even at the sacrifice of all other considerations. It may be that proportionately to the thickness of metal, there is no real necessity for placing a riser here for feeding purposes; but as this

is the highest part of the casting, the riser is indispensable, in order to relieve the dirt or kish which is sure to locate itself in this part. While clearly showing the necessity of the risers on the highest parts, it is likewise necessary to place risers on other parts which may have considerably thicker metal, necessitating feeding, as often occurs with certain castings or parts of castings.

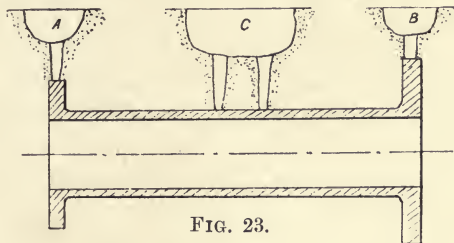

FIG. 23.

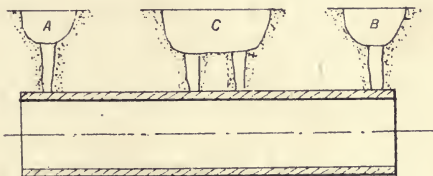

FIG. 24.

In Fig. 23, riser *B*, it will be seen that the flange is much larger than that at *A*, at its opposite end. Of course this flange is proportionately thicker, in consequence of which this part of the casting is longest in setting; and with no application of the feeder here, the only result possible would be what is termed a "drawn hole," showing itself probably to a considerable depth into the casting. This would be more intensified were the riser of a small size—say, one-third the thickness of the flange. The riser *B* should be of an oblong shape, its breadth being not more than a $\frac{1}{2}$ in. or $\frac{3}{8}$ in., less than the full thickness of the flange. It must be obvious from

¹ Except those parts in immediate contact with the pouring gates.

this increased size that the riser gate remains fluid for a longer period, which in its turn has the better chance of feeding the flange, even though no rod be applied.

While such a gate as the one described may be reckoned as a factor of safety in securing a solid flange, it by no means guarantees a solid casting, and entire satisfaction can only be obtained by the use of such a gate and the action of the feeding rod. In Fig. 23, basin *A*, the flange being considerably less, there is no real necessity for applying the feeding rod here, as many moulders do. We have used Fig. 24 as a contrast to show the difference of a cylindrical body without flanges in its relation to risers and feeding. A casting of this type has the same necessity for risers as the previous one, with this difference—that in Fig. 23, *A* may be said to serve a two-fold purpose, that is, while relieving the mould of its dirtiest metal (which invariably makes for the highest part of the mould), it also serves the purpose of feeding; but as Fig. 24 shows no flanges, and there is nothing but proportionate metal throughout, feeding is not a necessity. But it is equally necessary that the gates at the extremities should be there, in order that these parts of the casting may be as clean as it is possible to get them. It will be seen from the figure under consideration that the metal is striking right across the back of the core and finding its way to the bottom; it gradually rises right to the spot where it first entered the mould, but on its return, it had laden itself more or less with an accumulation of dirt, and may be dull owing to oxidation. Hence the need for the end risers.

Next we will take up the question of the open or shut riser at time of casting. It is stated by those who seek to uphold the open riser that the increased volume of air and gas under pressure naturally seeks for a speedy exit, and if refused such, the result can only be detrimental to the mould in causing scabbing. Then, again, they maintain that by keeping the risers open the dust caused by the motion of the gas finds an easy way of escape, which is the means of securing a sound and clean casting. This sounds all very well in theory, but it is sometimes forgotten that with closed risers there is no current of gases blowing off. No two moulds can be said to generate

gases alike, they at all times being dissimilarly placed through variation of temperature and dampness inherent to the sand and atmosphere. Take as an example a dry-sand mould which is comparatively free from gases; it is of little consequence whether its risers be open or shut. Should the gases be blowing off with considerable force, there is no dread of anything going wrong with the mould, the strength of which is more than able to resist the strongest current of gases possible. Then, again, the gases being almost *nil* compared with a green-sand mould, we have always been inclined to leave the risers open, such being the means of allowing any steam to escape caused by dampness created, it may be, through the stamping of "bearings" or daubing of joints with loam.

The treatment applicable to risers in dry-sand work is equally good for loam. But to return to the most critical point, namely, risers in heavy green-sand work, we would in every case advise those who have to handle such to adhere rigidly to closed risers.

We may now make a brief allusion to the advantages of compressed gas sustaining a mould at the time of casting. But before referring to this point it would be well to consider from whence those gases come. In a green-sand mould the sand may be said to contain about 20 per cent. of coal (for heavy work) in the form of coal-dust, which is ground to the finest possible condition; then the other ingredients in the black sand, which forms a good part of the bulk of the facing sand, contain in a moistened state what may be termed "marshy matters," all of which combine to form the gases referred to. A mould that is ready to receive metal can contain nothing but air, but immediately molten metal enters such a mould the gas begins to generate, and is intensified in pressure until the mould is finally filled, such gases being forced to make their exit through the interstices of the top part and the surrounding vent holes which usually accompany green-sand moulding. This is one of the primary advantages which are to be obtained by the risers being closed. Again, if we consider the interior of a mould, we shall see what advantages are to be gained with such a mould under gas compression. The fact of such gas under pressure seeking for an exit goes a

great way to sustain the whole interior, and no part of the mould is more sustained than the top, this part being the most liable to "drawing down" through the heat of the metal, and more especially is this so where the mould is too long in filling. No such advantages as here referred to can be got with the open risers, as the gases under such conditions are supposed to pass freely through the risers as they generate in the mould, therefore we should continue to keep to the closed riser, especially in green-sand moulding, knowing that with such it is an impossibility to err in so far as the treatment of risers is concerned.

CHAPLETS -

Chaplets are a necessary evil that moulders will probably have to contend with so long as castings are made. One can scarcely think of them being in a casting without doing more or less harm, and although in hundreds of cases the evil never shows itself, the weakness of those parts where chaplets are embedded would be very apparent if the casting were broken up. At the same time chaplets can be used, and when intelligently applied do no serious harm to a casting either under steam or water pressure. The indiscriminate use of chaplets has been the means of losing many a good casting, and the safest rule for moulders to go by is to add a little more metal wherever it is necessary to employ a chaplet. If this be carried out it will certainly give the greatest satisfaction to all parties, since it is an admitted fact that chaplets cannot be interspersed among the cores in order to keep them in their places without weakening the metal.

It is scarcely permissible to place a chaplet on any part which may have to be polished, but in cases where it is necessary to have one or more the only way to get over the difficulty is by bedding the studs half an inch or so below the surface of the mould. These projecting from the face of the casting can be easily chipped off by the dresser or fettler at the time of cleaning the casting, and when machining takes place the worst that can be noticed is a white spot on the finished surface caused by the malleable iron being denser than the cast iron which enshrouds it.

Many of the methods adopted in foundries to overcome the tendency which chaplets have to create blowholes are quite unsuitable, and the tarring process, as it is known to moulders, is perhaps the worst. I have worked in shops where it was the only remedy in use. Now, if I were asked what would be the best thing to do to admit of a mandrel being easily taken from a casting, I should unhesitatingly say tar it. The only way to get a casting with a tarred chaplet steam or watertight is by casting at a temperature higher than is good for the mould generally. This high casting temperature enables the metal to destroy part of the coating of tar before settling down. The application of chalk also cannot be recommended, although it is regarded by some as having a beneficial effect in absorbing water and preventing the formation of watery beads which condense on the chaplets in every green-sand mould which is closed for any length of time before casting. Again, many pass chaplets through the fire, and this is not without good effect. The dust, however, which adheres to the burnt chaplets after this treatment is objectionable, and they should never be used until they have been coated with oil. The oil promotes the union between the metal and the chaplets by the reduction of the oxide of iron on the surface of the latter. Indeed, chaplets that are comparatively clean are quite safe with oil alone.

Tinning of chaplets is commendable, and where this is properly done it has its advantages over some of the cruder treatments. As this adds considerably to the cost it frequently happens that a compound of spelter and tin is substituted, which has a detrimental effect, and cannot give the result desired. Although tin has the greatest affinity for cast iron, and in that way, I believe, has the greatest acceptance among moulders, still, this has not been found the panacea for all ills that accompany the use of chaplets. Wherever these are in use, moulders would do well to see, first of all, that they have been dipped in pure tin, and not galvanised as frequently happens; also to make sure that the dipping has been perfect and complete, as chaplets that remain a long time in store become rusted on those parts that have been imperfectly tinned. And a chaplet used in this condition cannot do otherwise than disturb the metal, thus

creating blowholes in contact with the rusty part referred to. However, by dipping such a chaplet in creosote the oxide of iron will be destroyed, and affinity with molten iron secured.

To paint with red-lead is an old device, and so far is serviceable with certain classes of castings ; but castings that have to withstand hydraulic pressure certainly will not do well with chaplets so treated, because, were one to rub or coat a chaplet with dry red-lead putty it will be obvious that no adhesion could take place between metal and chaplet. Hence, the only hope is in the red-lead as a paint, and, through the oil in the paint, combustion takes place as the metal surrounds the chaplet, resulting in a fair amount of success generally.

And now for the last of those antidotes, which is the best, cheapest, and most commendable of all, viz., creosote. It does not matter how rusty a chaplet may be, this liquid is at all times capable of making it fit for use. The truth of this assertion may be demonstrated in the following way : Take a piece of rod iron, no matter how rusty, dip it thoroughly in creosote, and then put it into a ladle of molten iron, and that which otherwise would have created an explosion, is received by the iron with comparative placidity. As this mode of treatment costs so little in time and money, chaplets, although tinned, are safer when given a coating of creosote.

SHRINKAGE

There is perhaps no property of metals which gives more trouble to the founder than that of shrinkage, and intelligent observation and careful thought are needed if he is to deal successfully with the daily occurring problems connected with it.

The loses amongst our engineering craftsmen and others due to lack of knowledge of the effects of expansion and contraction have been at times demonstrated to us in practice. For instance, take the case of a double beat valve, whose different parts are cast of different metals such as gunmetal and iron, which when exposed to the same heat while working gives very unsatisfactory results due to want of uniformity of

expansion of the different metals of which the parts of the valve are cast. Under such conditions of heat the valve face becomes faulty, and cannot act with the precision which goes to make a good valve. Consequently all constructions that are exposed to heat must, as far as possible, be cast of the same metal so that there may be uniformity of expansion and contraction of all the different parts. The importance of this no one can over-estimate in any form of constructional engineering, and the branch of engineering that does not necessitate a knowledge of the laws of expansion and contraction, is not known to the man of experience.

The term "shrinkage" is used here in a general sense, and includes all volume changes that occur in the metal from the moment that mould is completely filled until the casting has reached the ordinary temperature. It may be said with safety that no iron with which the founder has to deal contracts regularly as the temperature falls; indeed, in many cases shrinkage may conveniently be considered as occurring in two stages. The first stage covers the interval between the filling of the mould and the complete solidification of the metal, and is the cause of "draw," vacuum holes, and what are often incorrectly called "blowholes." The second stage occupies the period between the complete solidification of the metal and the ordinary temperature, *i.e.*, until shrinkage is finished, and the metal reaches a state of what may be called "absolute shrinkage"; during this stage the effects of shrinkage at times are seen in warped and twisted castings. The effects of shrinkage are thus of two kinds which may be called internal and external—the former, such as draw and shrinkage holes, occurring while the metal is in the fluid and plastic states; and the latter, such as warping and twisting, which take place chiefly after the metal has solidified.

The internal effects of shrinkage are often seen in spongy, porous and weak parts of heavy castings. This effect is intensified at junctions or attachments where the cooling is less rapid than in other parts, but these unsound junctions usually only reveal themselves under the hydraulic test. Design and proportioning of thickness are thus important factors since properly proportioned thickness gives uniformity of shrinkage

and uniformity of shrinkage gives elasticity and strength. Those whose duty it is to design should see that they avoid objectionable angles when designing for the foundry, because what might prove a first-class design for constructional work, would as likely as not mean irretrievable loss in the foundry through irregularity of shrinkage.

We now pass on to the consideration of the shrinkage of metal causing warping or twisting, due to unequal cooling. In this phase of shrinkage it is not so much a case of unequal distribution of metal, as a question of conditions relative to the position of casting. Certain articles have a tendency to twist in cooling, but if turned upside down in casting the result would be quite different. For example, take a casting of U section and of equal metal, and first cast this job with the bottom down. The bottom side of this casting will then inevitably remain hot considerably longer than the sides, and the result is always found to be that both ends will incline downwards and thus concave the casting. Next mould a second one from the same pattern, but this time with the bottom upwards, so that what was formerly the hottest part of the casting, is now more exposed to the atmosphere, and consequently brings about a more uniform cooling, a result much to be desired, but at times a practical impossibility. There is no absolute rule that must be followed in this branch of founding, as everything cast has its own peculiarities in cooling, and nowhere do we find the trouble of warping more pronounced than in the shrinkage and contraction of light and hollow castings. It should be remembered that the central and inside parts of castings cool less rapidly than the outside and ends. Hence follows the concaving of castings of U section when cast downwards, the extremities of the castings being turned inwards under the influence of the unequal rate of cooling. Therefore the camber in the bedding down in this position of sole-plates and bearers of U section requires to be deflected in the middle, so as to bring these castings straight from the mould.

In this connection the responsibilities between foundry and pattern shop are frequently disputed. Wherever this is the case, it ought to lie with the founder to decide the question,

unless the pattern shop assumes responsibility in those matters, a thing not usually done.

Obviously, castings of the hollow type, whose average thickness of metal may approximately be put at $\frac{1}{4}$ in., do not lend themselves to the troubles of shrinkage attending the production of thicker metal castings. And as a matter of fact, if there be a plastic condition in light work, with castings that are newly poured, it must only be of momentary duration. Consequently no irregularities of shrinkage causing "draw," as are common with heavy sectional metal, can possibly take place. However, those engaged in hollow work, may think they have plenty to contend with in "warping," a trouble due to shrinkage which is scarcely known to some heavy metal workers.

The habit that some light metal moulders have of "baring off" castings at certain parts to secure uniformity of cooling is not, in the writer's opinion, good practice. All such operations, however carefully performed, must deteriorate the casting by "shortening," or unduly hardening the grain of the metal, which at best, can do no more good for the purpose intended, than is to be got from the more rational method of camber.

It is well known that the internal structure of all metals, whether cast or forged, is influenced by the rate of cooling. Hence it comes about that the casting that is allowed to cool, closed up and undisturbed in the moulding box in which it has been cast, proves to be a casting of the softest texture of metal possible and a superior casting for all concerned. The best and most experienced moulders know that conditions such as unequal exposure to wind and weather, gates for running and rising and where to place them, position of casting, inequality in the dampness of the sand, and perhaps two castings in one box instead of one, are all factors to be reckoned with in securing straight castings from the sand. These are not trifles, since, for example, in lengthy castings, where two are cast side by side in one box, a twist sideways is sure to follow. This is due to the fact that the two insides of the castings are longer in cooling than their outsides.

Design.—The casting illustrated in Fig. 25 has four equal sides. Its diagonal bar in foundry designing is exceedingly

bad, and wherever employed gives evidence of limited knowledge concerning the effects of shrinkage in castings. Diagonal bars, however serviceable in structural work, are at all times mischievous to a greater or less extent in castings. Fig. 25 shows in its worst form the results of unequal shrinkage, and the casting would be found to be warped or unduly strained, if not actually broken.

Fig. 26 may be looked upon as a better way of strengthening a casting, and experience has proved that results are more satisfactory than with the design shown at Fig. 25, but while admitting Fig. 26 to be superior, both are objectionable, the only difference being, that in Fig. 26 the strain is better

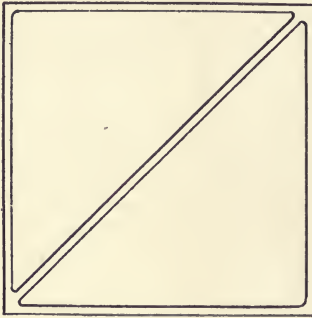

FIG. 25.

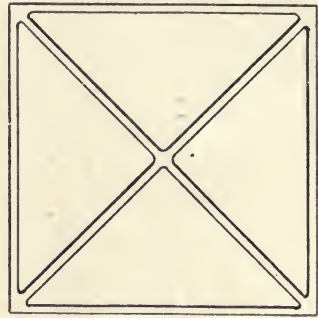

FIG. 26.

balanced on account of the opposing action of shrinkage through the additional diagonal bar, which brings the strain from the four corners to the centre alike. Again, although Fig. 26 has an improved balance of strain, still, with a casting so designed there cannot be absolute equality of shrinkage; but another way that such can be improved is by plating the entire surface over with proportionate metal. This plating of the surface tends to give uniformity of shrinkage, although not absolutely so, as the centre has the last of the pull in shrinking. Diagonal design from corner to centre is not advisable; therefore, wherever diagonal bars are designed, their elasticity is improved by quarter circles as shown at Fig. 27. This is a capital design for tank plates, and is better when not more than $\frac{3}{4}$ in. to $1\frac{1}{4}$ ins. in depth for the plate mentioned. A

plate thus designed is much improved in elasticity, a factor of considerable importance when designing cast iron. It not infrequently happens that the projections or ribs, as shown, so add to the strength of the casting as to make it not inferior to a plain plate double the thickness. Thus with a plate $\frac{3}{4}$ in. thick strengthened with the projections referred to, there will be greater spring or resistance than is possible with a plain plate $1\frac{1}{2}$ ins. thick.

In the case of the design shown in Fig. 25, some may say that the diagonal bar, although it has a greater length to travel in shrinking, will do so proportionately, and that all in the end will shrink and finish as one. In theory this may be true, but in practice I have never found it so, and in this particular

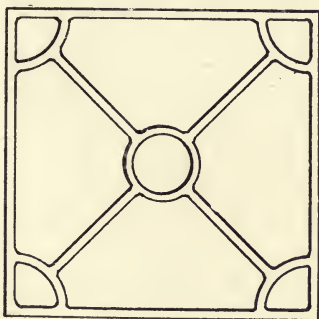

FIG. 27.

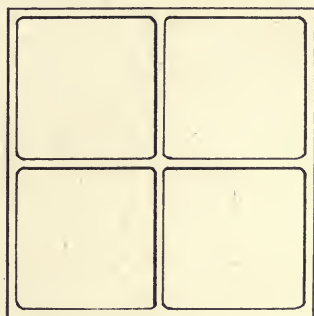

FIG. 28.

case I can attribute this variation of shrinkage to nothing but the variation of cooling. It will be obvious that the four sides must cool first, and the diagonal bar, being enshrouded with the heat from the outside part of the casting, must of necessity shrink in the wake of the sides, thus causing warping, undue straining, or fracture of a casting of the type of Figs. 25 and 26.

The great question in designing for the foundry is to see that in doing so all parts, as far as it is practicable, shall shrink together. Therefore, to rib after the fashion of constructional work is a great mistake, and anything so treated with the design of Figs. 25 and 26, cannot, in the opinion of the writer, have equality of shrinkage.

Metals from 1 in. to 4 ins. in thickness, of design shown in Fig. 28, I never saw fail, but experience has proved other

designs to be failures, and in some cases failure did not take place until the castings had left the foundry, and as might be expected resulted in serious loss to all concerned.

Equality of Metal.—Although not always possible, equality of metal is much to be desired, and the greater equality the less undue strain will follow the shrinkage of all metals cast.

Many cases could be cited in support of this, but the most common is that of the ordinary belt pulley with its necessarily heavy boss. Every practical moulder knows that it would be useless to expect these castings to keep from springing or snapping, unless they be either split in the boss or other means adopted to expedite the cooling of the boss, so that rim and boss may cool together.

The method usually adopted in facilitating the cooling of the boss is to fettle out the core and apply cold water with discretion. Some engineers have an aversion to the use of water here. They maintain that cold water hardens the boss, thus making it objectionable for tooling. I agree that unless the water be applied intelligently it will work mischief. However, no one need be afraid of harm being done if they take care while applying the water to see that the boss returns to a greater heat in the bore than it possessed when receiving the last application of water. Another way to cool these castings evenly is to take off the cope and dig a gutter round the rim, and fill this with hot metal in order that the rim may retain its heat for a greater length of time, the object of this being to cool rim and centre uniformly and thus prevent the casting from springing in the arms or rim. This method of treatment is hardly, perhaps, the ordinary way of doing things, but it illustrates the kind of device moulders sometimes have to employ in order to secure good castings from what of necessity are badly designed patterns so far as shrinkage is concerned.

As another example take the spur-wheel type of castings which are fairly proportioned in every part, the boss metal being determined by the thickness of metal at the pitch line of the teeth. Yet, when we consider the relatively larger amount of heat in the heavier metal of the centre, and that

arms and rim cool first, it is easy to understand that there must be undue straining of some part or parts of the casting.

If no special treatment be given to such castings, the weakness invariably locates itself about the centre of curve on the spokes adjoining the rim, and this defect is always greater with the cross section spoke, and is therefore not so observable with the H spoke type of casting. Needless to say, the splitting of the boss goes a long way in relieving the strain which would otherwise be on the rim, the splitting being done by plates or cores, the latter being preferable. I have never seen it necessary, even in a 12-ft. diameter "spur wheel" and, say, 7 tons weight, in cast iron to split in more places than between two opposite arms; but were anyone to attempt even a much smaller diameter in steel, such would more or less end in failure, if split in only two places, through the casting concaving itself out of truth, thus making it impossible to gear with its pinion. Therefore, assuming a six-spoked wheel to be *cut in two places for cast iron*, it would take *three in steel* to avoid concaving.

Camber and uniformity of cooling.—To camber a pattern in bedding down is to give it the necessary deflection, in order that the casting made therefrom will come out of the sand without being warped or twisted. Practical men are aware that there is no fixed rule to guide them here; it is all a matter of experience gained through jobs previously passing through their hands, and even then the moulder receives surprises, for it does not always happen that two castings, made from the same pattern and by the same moulder shrink alike. The reasons for this are various. First of all there are atmospheric conditions to contend with. For an example, let us take a horizontal engine bed plate (Fig. 29), which may either be 20 ft. or 40 ft. long—the length does not matter, except that in the greater length the danger of warping will be practically doubled. Now, suppose one end of the casting is in close touch with the door of the foundry, and a strong wind blowing on this exposed part while the other end was in comparative warmth, it is evident

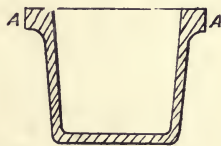

FIG. 29.

that the exposed end will cool much more rapidly than the rest of the casting.

Further, if we reckon the camber of $\frac{1}{2}$ in. on a 20-ft. length, of Fig. 29, that is, $\frac{1}{2}$ in. deflection in the centre, any alteration of the metal, as shown at *AA* in Fig. 29, would have to be reckoned with; that is to say, were we to add to the depth of the metal on the base *AA* we retard the cooling of this part of the casting, and with one-third more metal, the chances would be that no deflection at bedding down this job would be necessary. But on the other hand, if the metal was reduced on the same parts by the same proportion, producing an opposite effect, then the camber in such a case would require a proportional increase.

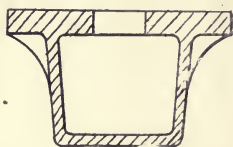

FIG. 30.

The foregoing is only applicable to those sections of Figs. 29 and 30, when cast in the position as shown here. The gates and risers should also be attended to so that these may be relieved from all possible gripping on the bars of the cope or box with which the casting is covered. And, should a casting require more than two separate flasks, it is necessary to remove all but the two end ones during cooling and before shrinkage is complete.

Fig. 30, although of a similar design to Fig. 29, is heavier metal along the base, besides being "boxed." If in bedding-down the pattern for such a casting one were to camber by deflecting the middle, as referred to, this would be exactly the opposite to what would be required to make a straight casting, because the heavier metal on the top side of Fig. 30 makes this part the last to cool, and hence the last to shrink.

So far we have only considered uniform design with the usual attachments for binding bolts, cylinder feet and pillow block faces; and wherever there is nothing more than these to contend with, the difficulty of making straight castings is not extraordinary. But the tendency in these days is to design regardless of the consequences attending shrinkage. It has now become quite common to cast on to the sides of

castings projections of various forms which hitherto were jointed and fitted, thus intensifying the danger of twisting or warping while cooling.

In short, we have complications of design and varieties of thickness in one casting, ostensibly for the purpose of reducing machining and fitting, with a view to producing the greatest economy possible. This may be so far correct for the departments referred to; nevertheless, these attachments or complications have made moulding more than ever an art, and have given demand for a degree of skill and ingenuity hitherto unknown in the trade.

But wherever these heavy projections occur, and are likely to be considerably longer in cooling than the rest of the casting, dig round with discretion and expose these parts, and so bring about uniformity of cooling as far as possible.¹ Indeed, there is no absolute uniformity of cooling, and the nearest we can get to this is in a straight bar, or plain plate or frame, and even the centres of the former inevitably keep warmest until shrinkage is completed. Moreover, a straight plate and a straight bar are the only castings that I can think of that are free from shrinkage strains, internal and external, a trouble so common to castings poured with every kind of metal.

But although founders should be competent to overcome all difficulties caused by abnormal design or attachments, they ought to let those responsible understand that these difficulties and complications involve much risk to the founder; a good understanding between the drawing office and the foundry will reduce the risk of loss from this cause to a minimum.

Shrinkage by Premature Exposure.—We shall but briefly refer to this part of the subject, although its importance is great; and we may be pardoned by what has previously been stated, if we confine ourselves for the present to castings which may have been lifted from the sand too soon or too late. With many castings, that are prematurely exposed to the atmosphere, external shrinkage must considerably

¹ In cases where, through unusual inequalities of thickness or design of soleplates, such means do not give sufficiently uniform cooling it is better to "split" in some convenient part rather than have castings unduly strained by unequal shrinkage.

develop before internal shrinkage has properly begun, and is aggravated when valve-seats and other internal adjuncts in effect consign a casting thus treated to a short life, if nothing worse happens, through such unguarded treatment.

Castings that are to be polished, but otherwise plain, even when cast with iron above the average density and price, if left too long in the sand bring about a change in the condition of the carbon, and instead of getting a polished casting with a fairly good lustre, we get a dirty speckled article, an eyesore to the founder and a short-lived article to the buyer, that is to say, if it belongs to the anti-frictional grade of castings. Thus a poor and cheap brand may be improved by careful treatment, and a superior and costly one spoiled by carelessness, want of intelligence, or perhaps both.

Although we have thus specifically stated the dangers attending premature lifting of castings, and also, on the other hand, shown its advantages in certain cases, it is not to be inferred that all castings are injured by premature lifting. There is an old saying which says, "One man's meat may prove another man's poison;" so in like manner, one casting's imperative treatment, if applied to others, would in many cases scrap the castings. Thus it is that castings of equal thickness and absolutely free from irregular shrinkage, are perfectly safe when lifted somewhat prematurely. Straight pipes, railway chairs, and such like castings are free to be dealt with in the matter of lifting them from the sand, after being cast, as circumstances best permit. Consequently, the subject of heat treatment, or the tempering of castings, although absolutely essential for some work, is unimportant to other castings in the trade.

Slackening.—Castings that are gripped at both ends, such as is the case with long columns in dry-sand, have no need to be slackened at both ends, as slackening at one end will suffice. It is true that the pull in such cases of shrinkage will all be from and towards the one end. But with things in normal condition for shrinking, no harm can befall a casting thus treated, while the unnecessary trouble of slackening at both ends is saved.

It need hardly be said that the need for slackening castings

is almost, if not altogether, confined to dry-sand and loam work in the form of moulds and cores. And if many castings moulded in green-sand were made in dry-sand or loam the need for slackening would be imperative.

Those who handle loam work should know what will be the total amount of shrinkage on parts requiring "slackening," because the rigidness of loam moulds and cores compels the relieving at times of some parts to assist the casting to contract. And for this reason the interspersion of loam bricks is frequently resorted to; but I do not favour such a system or method in the building of vertical cores, since this must at all times be a source of weakness. By far the better way is to distribute the equivalent of the loam brick space throughout the joints of the bricks in each course of the structure, and by doing so we get no less flexible material as a whole, and a positive guarantee against weakness, which accompanies the interspersion of loam bricks as above mentioned.

Loam moulders would do well to consider this division of the subject, on account of the rigidness of the materials with which their work is moulded; and where projections, or such-like, on castings have to travel by shrinking, they ought to see that loam brick be placed next to the metal. Also, a packing of ashes between the joints of hard brick will very much facilitate the ease and safety of shrinkage.

In studying Fig. 32, which is supposed to represent a cylindrical casting 6 ft. in diameter, with bracket attached, it may be asked, When should slackening begin? The earliest possible time is generally late enough, and with the job in question cherry-red heat would be some time past before the work of slackening could begin. Of course, it may be said by many that slackening is not necessary. Moreover, I have even come across men who maintained that they had seen as much evil resulting from slackening as any good they ever saw it do. I cannot agree with this, as my experience is all in the other direction. The one point to know is what to slacken and what to leave alone.

The barrel core in Figs. 31 and 32, or any other similar core, will yield to the extent of $\frac{5}{8}$ in. or $\frac{3}{4}$ in. before

shrinkage is complete. True, a great deal depends on the intelligence of the moulder who builds the core, and if the metal be 2 ins. thick the danger of such a casting cracking through rigidity of core, although not slackened, might not be serious; but reduce the metal to 1 in., then slackening becomes an absolute necessity. In the 2-in. metal we may assume that there is double the strength, and a consequent elasticity, which gives it more power while shrinking to crush, burn, and destroy the vegetable and combustible elements in the loam from which the core is made; but with 1-in. metal we are quite safe in assuming that the half of this destructive power is lost by the metal being closer grained,

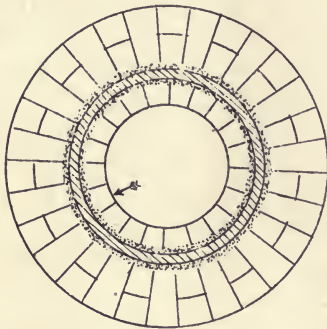

FIG. 31.

and as a natural consequence its elasticity is reduced also, thus making it impossible to withstand the necessary strain, consequent on $\frac{3}{4}$ -in. shrinkage on the core, as shown at Fig. 31. Then, when the metal's power to crush the core ceases before its work is done in shrinking and the limit of elasticity of metal is gone, nothing can save the casting from snapping, if it be not slackened, as shown at the arrow (Fig. 31).

This consists of the entire removal of a vertical strip of brick from top to bottom of the core. Immediately after this operation the top should be covered across and closed up tightly so as to prevent cold air playing upon the part relieved. This done, no ill can possibly attend the process of slackening.

Now, as to the vertical shrinkage of the job in question, and as shown at Fig. 32. Supposing this job to be about 12 ft. long, which would produce about $1\frac{1}{4}$ ins. of shrinkage, this means the top flange when shrunk must be nearer the bottom than it was immediately after being cast. Such an amount of shrinkage shows that everything likely to interrupt its progress should be slackened, otherwise results

at best will be defective. At Fig. 32, and underneath the top flange at *A*, is seen the amount of slackening required. If a plain barrel with flanges at both ends, say, 12 ft. long, no matter whether a loam brick is built underneath the top flange or not, slackening as shown ought to be attended to. But with a bracket *E*, as shown in same figure, slackening is absolutely imperative. In doing so, come down stepwise from the line of *A*, and get underneath the bracket at *C*; in this we fulfil the double function of preventing it from cracking and, ensuring the metal structure from being racked, thus improving what is naturally the weakest part of the casting. Care should be taken to see that the claw or flange of the bracket *D* has full liberty to shrink, otherwise the barrel may concave itself on this part of the bore which would mean at least an extra "cut" while "boring," should nothing worse happen.

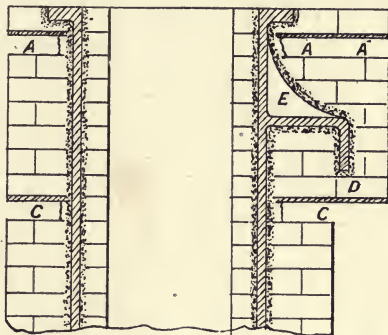

FIG. 32.

To sum up this question, it might fairly be put thus: All which has been said, from a founder's point of view, resolves on the one idea of uniformity of cooling, for if founders could get this, together with no impediments in the process of shrinkage, neither warping, concaving, convexing, breakage, nor burst of any kind could happen.

PRESSURE OF MOLTEN IRON (FERROSTATIC PRESSURE.¹)

Moulders who are accustomed to work by rule of thumb generally have hazy notions as to the influence of the pressure of the fluid metal in straining, bursting, or lifting the cope of a mould. This haziness is probably the result of the failure of some writers to apply their principles to the everyday

¹ "Ferrosstatic Pressure" is here suggested as a convenient term.

wants of a foundry. It is only in the hope of clearing up some of these difficulties that the writer has ventured to touch upon the rudiments of this subject.

Pressure on the Bottom of a Mould.—All liquids exert a pressure on the bottom of the vessel in which they are placed, and this downward pressure depends on the depth of liquid, and also on the specific gravity of the liquid. It is quite independent of the area of the bottom, that is, it does not matter in the least whether the bottom is large or small, the pressure per square inch is just the same. Since the liquids with which we have to deal have large specific gravities, this downward pressure is very considerable, and it is worth while to compare it with that produced by a corresponding quantity of water. A column of water 1 in. square and 28 ins. high weighs about a pound, and consequently if this column is placed in a vertical position there is a pressure of 1 lb. weight at the bottom; in fact, any head of water 28 ins. in vertical height produces a pressure of 1 lb. weight per square inch at the bottom. Thus, if a mould were filled to a depth of 28 ins. with water every square inch of the bottom would be subjected to a pressure of 1 lb. weight, no matter whether the sides are vertical or sloping inwards or outwards; if the depth were 56 ins. the pressure per square inch would be 2 lbs. weight, and so on. Now, suppose this same mould is filled to the same depth (28 ins.) with fluid iron, the specific gravity of which is, roughly, 7, *i.e.*, fluid iron is, bulk for bulk, 7 times as heavy as water. Each column of iron 1-in. square and 28 ins. high weighs 7 times as much as the same quantity of water, *i.e.*, it weighs 7 lbs., and consequently there is a pressure of 7 lbs. per square inch on the bottom of the mould. If only filled to a depth of 4 ins. it would produce the same pressure as a depth of 28 ins. of water. Thus, in casting a 20-ft. plunger—not an unusual length in these days—there is a pressure at the bottom of the mould, without taking into account depth of pouring basin, etc., equal to a head pressure of about 140 ft. of water, *i.e.*, about 60 lbs. weight per square inch.

Pressure on the Sides of a Mould.—Every fluid exerts a pressure on the sides of its containing vessel, and this pressure gets gradually greater as we get further below the

surface. Thus, the side pressure at a depth of 2 ft. is twice that at 1 ft. below the surface. In the case of a mould filled with fluid iron the side pressure at a depth of 4 ins. would be 1 lb. weight per square inch ; at 8 ins., 2 lbs. weight, and so on. These figures refer to vertical depths below the surface, and not to actual distances along the sides, if these are sloping.

Pressure on Floating and Submerged Bodies.—Let us now consider the case of a solid body completely submerged in a fluid. Here the fluid exerts a pressure on every part of the surface of the body, *top, bottom, and sides* ; and the result of this is that in every case there is an upward pressure trying to push the body out of the fluid. By actual experiment it is found that this pressure depends only on the *size* of the body and the specific gravity of the fluid, the actual value of the pressure being equal to the weight of the fluid displaced by the submerged body. Consequently, if this body has a smaller specific gravity than that of the fluid—*i.e.*, it is, bulk for bulk, lighter—this upward pressure is greater than the weight of the body and so the body is pushed upwards until it floats. The actual force moving it is the difference between this upward pressure and the weight of the body ; this moving force may be called the lifting power. When the body floats it does so in such a way that it displaces a weight of fluid just equal to its own weight—hence the lifting power has become nothing. If the body and the fluid have the same specific gravity, the weight of the body and this upward pressure are exactly equal, and consequently the body will stay in any position in which it happens to be so long as it is completely submerged. If, again, the body has a greater specific gravity than the fluid, its weight pulling it down is greater than the upward pressure, and so the body sinks. In all cases this upward pressure is the same, no matter whether the body is a long way below the surface of the fluid or whether it is only just submerged, since the amount of fluid displaced is always the same.

As illustrations of these points, suppose a cube of wood of 1-ft. edge is submerged in water. The weight of the wood is probably about 45 lbs., while the weight of water it would displace when submerged is 63 lbs. Consequently, there is a

force lifting it upwards of 18 lbs. weight, and in order to keep the wood underneath the water it must be pushed down with this force of 18 lbs. weight.

Again, 4 cub. ins. of iron weigh about 1 lb. ; when submerged in water it displaces 4 cub. ins. of water, and this only weighs $\frac{1}{7}$ lb. ; consequently the iron sinks, its apparent weight being now $\frac{6}{7}$ lb. Now let us consider the case we have to deal with in core making. The specific gravity of sand is about $1\frac{3}{4}$, that is, it is roughly one-fourth that of iron, and hence sand floats in fluid iron just as wood floats in water, since the weight of the sand is only one-fourth that of the iron it displaces. Thus, if the sand core weighs 10 lbs. the iron

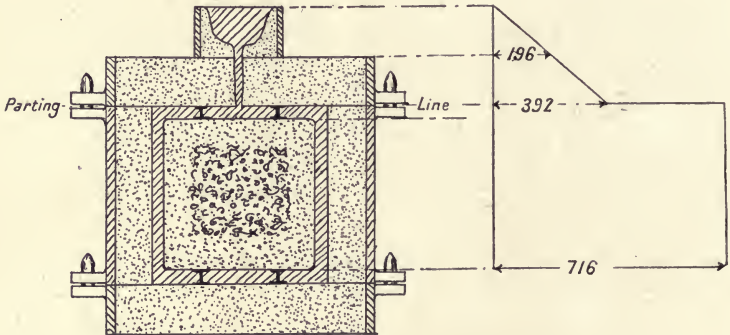

FIG. 33.

displaced weighs 40 lbs., and hence an additional pressure of 30 lbs. weight must be put on the core.

Pressure due to Fluid Metal in Gate.—As soon as the level of the fluid metal in the gate is above the parting line (v. Fig. 33) this additional head of fluid causes an additional pressure on all parts of the mould not only on the bottom and sides, but also on the top. Suppose this head of fluid is 8 ins. (depth of cope is 4 ins.), this additional pressure is 2 lbs. weight per square inch, no matter what the size of the gate may be—*i.e.*, both side and bottom pressures are increased by 2 lbs. weight per square inch. The pressure at the top is borne by the cope, and consequently this must be sufficiently weighted to withstand a pressure of 2 lbs. weight per square

inch.¹ This lifting pressure on the cope is confusing to many moulders, who do not distinguish it from the lifting pressure due to sand cores when submerged in fluid iron. In the latter case the pressure depends only on the volume of the sand core, and not on the area in contact with the cope, whereas the pressure on the cope due to the metal in the gate depends on the area of the surface of fluid metal in contact with it.

Again, suppose the mould in Fig. 34 is 12 ins. square and 1 in. deep, the cope of the mould has an area of 144 sq. ins., and so the total lifting pressure due to the fluid metal in the gate will be 288 lbs. weight (*i.e.*, 2 lbs. per square inch). If this same mould were placed on end, the area of the cope in contact with metal would only be 12 sq. ins., and so the total pressure to be borne by the cope would only be 24 lbs. weight, though in each case the weight of the casting is the same. In this connection it may be emphasised that it is very necessary to distinguish between total lifting pressure and pressure per square inch.

To illustrate further some of these points it may be of advantage to calculate the pressures experienced by the different parts of a mould in a few special cases.

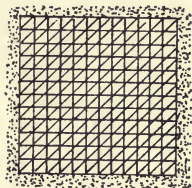

FIG. 34.

1. A solid cube, *i.e.*, a mould 1 ft. square and 1 ft. deep completely filled with molten iron (*v.* Fig. 34):

Pressure on bottom per sq. in. = 3 lbs. weight.

Total pressure on bottom = $3 \times 144 = 432$ lbs. weight.

Pressure on each side is nothing at the top, but gradually increases to 3 lbs. at the bottom.

Average pressure on each side, per square inch = $1\frac{1}{2}$ lbs. weight. Total pressure on each side = $1\frac{1}{2} \times 144 = 216$ lbs. weight.

¹ It must be borne in mind that the above calculations are only approximate; also all copes must be weighted according to risks from velocity or other contingencies of pressure or strain during the process of pouring metal into moulds.

2. A mould 12 ins. deep \times 12 ins. square with core 10 ins. \times 10 ins. \times 12 ins. deep in centre, plan of which is shown at Fig. 35.

Pressure on bottom per square inch (due to 12 ins. head) = 3 lbs. weight.

$$\text{Total pressure on bottom} = 44 \times 3 = 132 \text{ lbs. weight.}$$

Average pressure, on each side, per square inch = $1\frac{1}{2}$ lbs.

$$\text{Total pressure on each side} = 1\frac{1}{2} \times 144 = 216 \text{ lbs. weight.}$$

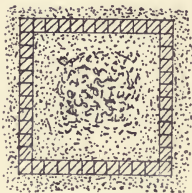

FIG. 35.

3. A mould 14 ins. \times 14 ins. \times 14 ins. deep contains a sand core 12 ins. \times 12 ins. \times 12 ins., the

level of fluid metal in gate being 8 ins. above the parting line (Fig. 33).

Area of bottom = 14 ins. \times 14 ins. = 196 sq. ins.

Effective head of fluid iron = 14 ins. + 8 ins. = 22 ins.

$$\therefore \text{Pressure per square inch} = \frac{22}{4} = 5.5 \text{ lbs. weight.}$$

$$\therefore \text{Total pressure on bottom} = 5.5 \times 196 = 1,078 \text{ lbs. weight.}$$

Area of each side = 14 ins. \times 14 ins. = 196 sq. ins.

$$\text{Average head of fluid iron} = \frac{14}{2} + 8 = 15 \text{ ins.}$$

$$\therefore \text{Average pressure per square inch} = \frac{15}{4} = 3.75 \text{ lbs. weight.}$$

$$\therefore \text{Total pressure on each side} = 196 \times 3.75 = 735 \text{ lbs. weight.}$$

Volume of sand core = 12 ins. \times 12 ins. \times 12 ins. = 1,728 cub. ins.

$$\therefore \text{Fluid iron displaced} = \frac{1728}{4} = 432 \text{ lbs.}$$

Suppose the sand core to weigh 108 lbs., then the lifting pressure to be resisted by the chaplets = 432 - 108 = 324 lbs. weight.

Area of metal surface in contact with cope = 14 ins.
 \times 14 ins. = 196 sq. ins.

Pressure due to fluid metal in gate = $\frac{8}{4}$ = 2 lbs.

\therefore Total pressure on cope, due to pressure of fluid metal in gate = $2 \times 196 = 392$ lbs., but to this must be added the lifting pressure due to core which may be transmitted to cope by chaplets, *i.e.*, 324 lbs.

Therefore the total lifting pressure will be $392 + 324 = 716$ lbs.

FEEDING OR THE COMPRESSION OF METALS

Perhaps no branch of foundry practice has given rise to more controversy, or to which more attention has been paid in trade journals than that of feeding, and it is proposed in this chapter to put into concrete form what has occurred to the writer in practice with regard to the feeding of castings.

To ensure success a founder must know how to mix and adapt the different brands of iron to the various requirements of the castings he intends to make, and what is the most suitable pouring temperature; but the question of the after-treatment of castings by feeding is probably of still greater importance; he must know what castings should be fed, and how this feeding should be done. The subject of the feeding of castings is intimately connected with that of shrinkage, since it is the shrinkage of metals during solidification that necessitates feeding. There are, broadly speaking, three stages or transitions in the cooling of metals from the molten state, *viz.*, (1) the liquid stage; (2) the solidifying stage, during which the metal is in a more or less plastic or viscous state; and (3) the solid stage; and it is while the metal is in the liquid, and the second or plastic stages, that feeding must be done.

The subject of feeding resolves itself into the following problems:—(1) Is feeding a necessity? (2) What class of castings should be fed? (3) How is feeding to be done?

(1) In answer to the first of those questions we are safe enough in saying that all castings, with but few exceptions, are fed to a greater or less extent in some way or other, and the only exceptions are those of extremely light metal, where immediate solidification takes place with uniform internal shrinkage. But, taking castings outside this range, the conditions are altogether changed.

A mould that is cast, and whose metal does not all solidify immediately such as is the case with varied sections, nevertheless forms its outside shell, so to speak, throughout, but specially at its extremities, while the still fluid interior "draws" from the basins (where no "emitting," as referred to later on, takes place) during solidification. This first formation of solid metal and plastic interior are important factors in the feeding of a casting.

It is true there never can be a fixed rule for feeding, as every casting brings its own peculiar wants with it, and so does every metal with which a mould is cast. But while allowing for these conditions, it must be borne in mind that feeding is a necessity, and whether we recognise this principle or not, castings are in a measure fed automatically, and not infrequently unknown to the moulder from the source above mentioned.

(2) What should be fed? This question may be a little ambiguous, since it has been laid down as a principle that feeding is a necessity in the solidification of metals. This admitted, it goes without saying that there can be but few exceptions; one of those exceptions having already been referred to need not be mentioned again, and the only other that I have ever experienced are those castings in which the emitting or vomiting of fluid metal from the mould takes place due to the expansion of malleable spokes, or it may be an occasional core expansion, such as in the case of barrel-jacketed and Corliss-cylinder moulds, with their complex group of cores so much enshrouded in metal.

As an example of malleable spoke expansion, let us turn our attention to the casting of what may be termed the bicycle-spoked pit-head pulley, or wheels similarly spoked. It is known to those with experience in this class of

work that immediately on casting the bosses of these castings a swelling action appears in the basins, and not infrequently a vomiting follows, and for anyone to put the feeder through the riser while such is going on would only aggravate the situation, with the chances of losing the pulley entirely. The substitute for a feeder here is a bucket with water, the contents of which are judiciously applied to the basins, so that a crust may be formed on the top, this crust to be used for the controlling of the emission of the metal from the mould. This is an operation that cannot go under the name of feeding, although it is at times erroneously termed so. The stratagem employed for solidifying these bosses is outside the province of feeding and need not be further referred to at present.

To return to the question of what class of castings should be fed, it looks a little elementary to say that wheel bosses of every description should be fed. The treatment of these castings but trace the surface of the question, and is known to the juniors of the craft. It is among the cores and at the fillets of attachments and projections of castings that moulders must search for the mischievous parts that are so vital to hydraulically-tested castings, and thereby gain the mastery in the detail of feeding.

As already mentioned, one cannot know too much regarding the importance of design, a thing, I am sorry to admit, few moulders trouble themselves about. Were this better understood by engineers and moulders alike, much of the work that is scrapped would otherwise be good castings. It is true the feeder cannot be got to reach all parts requiring its assistance; but other means can be applied, and, when judiciously administered, have the desired effect.

Again, let us view what comes directly under the eye of the moulder, and suppose we take a length of pipe, as shown at Fig. 36, of course flanged at both ends, the flange *B*, whose metal is proportionately thicker than *A*, is the last part to solidify. This being so, the whole casting, as it is settling down, must "draw" from flange *B*, so favourably situated by its extra height and increased fluidity for drawing, and doing damage.

Obviously, if this flange acts as a feeder for the whole of the casting, the flange in turn must be fed from the basin, and were this not so, the inevitable "draw" or vacuum holes would undoubtedly be on the top side of the flange. But the man who knows what should be fed could not be deceived here, as assuredly his experience would compel him to be careful about his riser basin, and with ample room in his feeding-gate to admit of the feeder being properly used nothing but complete solidification of this flange would be the result.

(3) In the first of the two preceding divisions there is shown the necessity for feeding, and in the second is also shown, in a very brief manner, what to feed; but, as has been

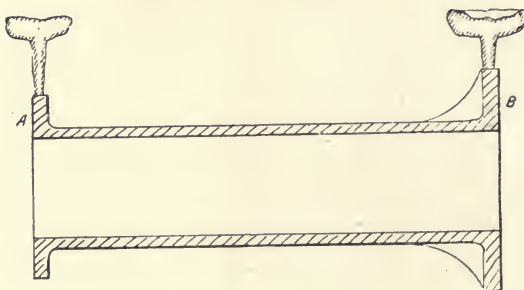

FIG. 36.

previously stated, individual castings require individual treatment, because the details of our methods are not infrequently a matter of compulsion rather than of choice.

Examples could be given by the score, but perhaps one or two may suffice. (1) Take the case of a cylinder cast on end (see Fig. 70), or in the vertical position, with feet and other attachments cast on it; were such a casting not well fed by some means or other, the possibility of getting it solid about the flange, and specially about the feet of the top end, would be practically *nil*. (2) Cast the same cylinder in the horizontal position and these defective shrink-holes, sometimes erroneously termed blowholes, entirely disappear. In the former position, which is the vertical, we have "centralisation of shrinkage," as the entire course of shrinkage is all towards the bottom end, and continues throughout the

different transitions of the metal until absolute shrinkage is accomplished.

Again, and to drive this point a little further, let us imagine for a moment that immediately the mould is cast there is a stoppage of supply of fluid metal from the pouring and riser basins to mould. There could then be but one result, namely, a more or less shell form of a flange would take the place of what would, under ordinary conditions of sinking-head and feeding, have been a solid casting. The result from such a procedure must be manifestly clear, and again shows feeding at times to be a necessity in some way or other. So much for the centralisation of shrinkage.

Now, to "decentralise" or distribute the above effect, the horizontal position is the best and will do it most completely. For, suppose the entire space of the shrink-holes on the top end of the cylinder (vertically cast) accounts for anything inside of half-a-dozen pounds, this does not mean much throughout the barrel, port, steam-chest, and other attachments of a cylinder lying in the horizontal position; indeed, all the loss of weight due to the space referred to might easily be compensated for by the *improved uniform density* of the metal which the horizontal position of casting produces.

Brass moulders who have to do with the finer metals know full well the difference between vertical and horizontal casting. Work which, in cast iron, is imperatively cast in the vertical position could not, in many cases, be so cast in brass, just because of its greater shrinkage when compared with iron. Not all the hot metal from crucible feeding or otherwise could equal the good effect of horizontal pouring with gates sufficiently large to give automatic feeding which may be assisted by the rod, if thought necessary. Further, how is feeding to be done? Many will doubtless answer this question by saying there is but one way of doing it, and that is to feed with a rod varying in thickness according to the necessities or wants of a casting requiring to be fed. This is but part of the answer to the question at issue. Some say that no matter what may be the details of a casting, feeding results are at all times more satisfactory when one feeder only is employed. To my mind those who argue thus must have but a limited

experience in the habits of metals and the production of general machinery and pump castings.

It is perfectly true that one feeder applied to any mould just cast will let its influence be felt with every stroke of the rod. This can easily be verified by the motion in the basins. But while admitting this, I am far from admitting that feeding, in the sense of the word, is being performed at this juncture. No, not until this period of motion is past does the real work for the feeding rod begin. Here we see that feeding is a purely local operation, and the rod, as wielded up and down by the moulder, becomes more a mechanical compressor, which practically has no power to feed, force, or compress beyond the immediate region in which it is being worked.

This is really the case with castings of irregular thick-

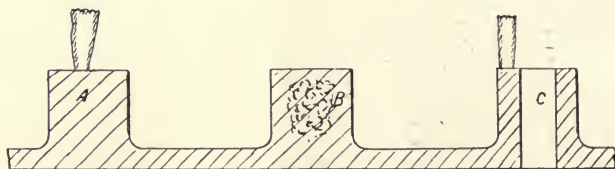

FIG. 37.

nesses, a thing not infrequently met with in the foundry, and by referring to Fig. 37 will be seen the meaning of what is stated here. As will be seen, this figure illustrates the effect produced by disproportionate metal, as seen at *A*, *B*, *C* (Fig. 37). Snug *C* is proportioned with the core running through it, which enables it to solidify with the general body, and which secures for it much the same texture as the part referred to.

It will be readily conceded that, before we could expect to secure solidity in snugs *A* and *B*, feeding must be resorted to. Suppose also we just applied the feeder to *A*, which produces the homogeneousness shown, and allowed *B* to take its chance, "draw" and sponginess would inevitably follow, as illustrated. Why is this so? It is because of the fact that the straight passage between these snugs *A* and *B* has become solidified while the snugs are still comparatively plastic; and with but one feeding rod operating on snug *A*, and snug *B* having neither

riser nor basin attached, of a surety "draw" and sponginess, as previously stated, would be the result.

Others say that to feed with a rod is a great mistake; just let the basins be drowned with cold water, and the core expansion in moulds, such as cylinder castings, etc., will be ample for all wants in feeding. And here let me repeat what I have previously stated elsewhere, that cores or any other interspersions within a mould, such as malleable iron, will, beyond certain limits, in my opinion, never feed a casting solid. Why this cold-water bath fallacy for the chilling of basins, as I have seen it put, I know not. But supposing, and for the sake of convenience we admit, the above to be capable of checking the emission of metal from a mould, what after that? A mould cannot emit and admit metal at one and the same time. Emission is only possible under fluidity, and not until plasticity of metal is reached does internal shrinkage practically begin, and then the work for the feeder begins in earnest also. Clearly it will be seen that the entire cause of feeding is shrinkage; consequently there can be no feeding from the opposite action, which is expansion. Hence, all that this latter force can or may do is to increase the density of the skin of a casting, but can be no aid whatever in densifying parts that have to set after the general-body of metal in any casting has solidified.

(4) In the preceding parts of this subject the treatment of castings by feeding has been dealt with only as it concerns those that are covered by flask, cope, or top part; but in order that every method of casting may be embraced in this subject, I shall now, although it may be somewhat imperfectly, deal with what is known in the trade as "open-sand casting."

It is almost superfluous to say that this class of work is but a very poor species of moulding, and were this a subject in which moulding is of primary importance, it would be unnecessary to say anything here on the matter of open-sand castings. Feeding or compression, however, is a question of the habits of metal, and it is hoped that even in open-sand work there may be found much that is of interest, especially as it affords simple illustrations of some important principles.

It may be said that we cannot feed without a rod, and as

open-sand work has no covering, how can it be fed? But, as is well known, there are more ways of compressing and densifying metal than by means of the mechanical force applied by the feeding rod. Thus in the case of a sugar-mill roller the long and laborious job of feeding (sometimes as much as one and a half hours being spent on this work), with its frequently unsatisfactory results, could be dispensed with, as experience has shown very superior results can be obtained by pouring these castings open.

The feeder in this method is the ladle with its hot metal supply used to keep this end of the casting longest fluid, and consequently doing its best to give all that the casting is craving for. Thus we get by this process of feeding improved density of metal at a minimum of cost, both to the employer's purse and the moulder's body. The sinking-head necessary for this method need not be of greater height than that which is required for pouring these castings flasked with pourer and riser basins in the usual way; and by a little stratagem in the

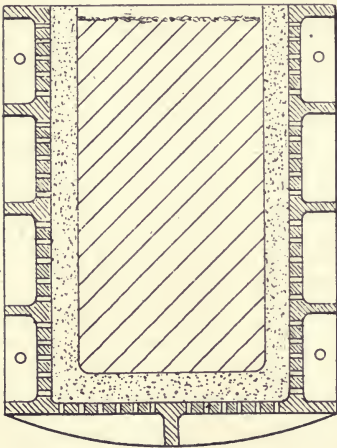

FIG. 38.

formation of the sinking-head there need be no great difficulty in breaking it off with a direct drop of the "ball."

The casting of a steel ingot is of interest in this connection. Something like 25 per cent. of these rough castings have in some cases to be cut off owing to the sponginess of their upper parts. This sponginess is the effect of shrinkage, and may be partly caused by the presence of blowholes or gas bubbles. Fig. 38 is supposed to represent an ingot casting while still perfectly fluid, and indicates that the casting is then practically homogeneous throughout. As the metal cools, solidification commences from the sides, and perhaps the bottom also, which are in contact with the mould, and soon after a crust of solidified

metal forms on the open top of the ingot. We have thus a solid shell of steel with a liquid interior, and solidification proceeds from the outside inwards, the part of the ingot which is the last to solidify being the upper central portion. During solidification and subsequent cooling shrinkage takes place, and the still molten interior is called upon to make good the contraction of the solid exterior, with the result that

there is a very considerable pull on the upper and central parts of the ingot, resulting in cavities and sponginess as seen at Fig. 39. If arrangements were made to keep the top of the ingot molten until the last, then although the head would sink, this molten metal would feed the rest of the ingot and prevent the formation of draw or shrinkage cavities. It must be remembered also that during solidification the impurities in the metal

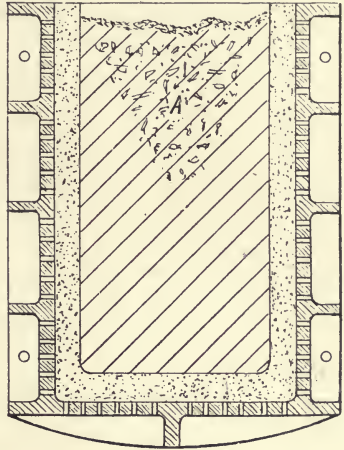

FIG. 39.

tend to become concentrated or segregated in those parts of the ingot which remain fluid longest, while the gases held in the molten metal and liberated during cooling cause *blowholes*, which are more numerous in that portion of the ingot. The upper central part of the ingot, as illustrated by Fig. 39, is thus spongy, contains many holes caused by shrinkage, is more impure than the rest of the ingot, and liable to contain many *blowholes*. For *open-sand feeding* see also Figs. 131 and 132.

METAL MIXING

Mixing and adapting metal will always be of prime importance in the foundry, but before a man is capable in this branch of founding, he must first of all have a knowledge of what duty is expected of the finished casting or castings. In addition he will need to have a thorough knowledge of the

common brands of pig iron available to the founder, an experience indispensable to those responsible for the output of good castings. With foundry metals there are two classes with regard to fluidity (the question of degrees need not trouble us)—the first includes metals high in so-called impurities, but somewhat deficient in density, and the second those less fluid which oxidise rapidly. Safety, from a founder's point of view, lies in the former being poured into moulds of intricate and thin metal section for pipes and lengthy castings where fluidity is of paramount importance and density is a subsidiary consideration. Dense metals that oxidise rapidly belong to the anti-frictional class, and are as a rule favoured when there are "short runs" and for contracted surfaces, such as cylinders, rams, and such castings as are bored. They are also suitable for castings which necessitate the vertical position in pouring, although not infrequently applied in horizontal casting, for which under special circumstances they may be quite suitable.

In founding, as in many other processes of manufactures, we are kept right, to a certain extent, by natural causes, for not even the uninitiated would expect to pour lengthy and thin castings with a metal that oxidises rapidly, such as a good cylinder metal should do, or cold-blast and hematite in suitable proportions. And the market price of metals is not without its guidance in the selecting or the adapting of brands to be used in the making of castings, because the best cold-blast cylinder metal, which approximately costs twice as much as common foundry grey iron, together with the enhanced price of hematite, offers a natural barrier against the mistake of using those for purposes other than that for which they were intended.

Mixing Iron for a Jobbing Foundry.—We purpose dealing here with the work of ordinary jobbing foundries, large and small, where the work done may include engine work, builders' castings, agricultural or hollow work. There is no limit to the variety in some jobbing foundries, and obviously it will not be possible to take all the items which might come within the scope of this section on "Metal Mixing."

From a scientific point of view mixing by analysis should give the most satisfactory results, and to ignore this method

of working would be unfair to the spirit of what is known as modern foundry practice. So far, however, it is only in a few large foundries that its practice has become possible; indeed, it is very questionable if it can be entertained in the generality of jobbing foundries. Those firms who make tub casting a specialty, and melt metal by crucible, and others who have a cupola set aside for specific work such as cylinders, and other heavy pieces of 10, 20, or 30 tons, have no difficulty in determining their mixtures by analysis, and acting accordingly; but in the majority of cases a shop's cast has to be made from one cupola, and here there is opportunity for planning as to the best times of charging to meet the various wants of the work that is on the floor. Hence it is that the founder prefers to cast cylinders with metal from the second and consecutive charges if need be, because the first charge carries an abnormal amount of dirt; besides it is usually dull in the first tap of two or three ordinary shank ladles, but improving, as a rule, after each successive tap, till by the time the first charge of, say, 12 cwts. has passed through the tapping hole, the metal following, assuming things are normal, should be in the best of condition for cylinder casting. In charging the cupola for cylinders, it is better to have in the cupola a charge of cylinder metal in excess of that required for casting the job. This will act as a safeguard in keeping the cylinder metal correct, and will also serve to cast other work throughout the floor requiring similar dense and strong metal which will give a good polish.

As we have indicated, the jobbing foundryman cannot determine or readily get at results by analysis; therefore, he must trust the ironmaster to give him what he asks and pays for, a thing common to all markets in buying and selling; still, if he wants good castings he must have suitable metal. But after all it is largely a matter of selection and adaptation rather than inherent good and bad qualities. Some founders seem chronically pessimistic as to their metals, while others do not make a serious affair of it, but, knowing that all metals smelted have their place in founding, seem to know from experience how to use, mix, and adapt them. All the same, some metals are more serviceable than others; therefore,

those responsible in the foundry will doubtless select their iron with care. Experience with fractures, aided by the magnifying glass, enables a man to decide fairly accurately what may be expected from ordinary foundry irons, irrespective of analysis or other tests. Moreover, the training of the eye required to gain all the information possible from the appearance of the fluid surface in the ladles is an education which chemists and practical founders alike would do well to acquire.

Cylinders and Engine Parts.—Jobbing foundries generally do a good bit in engine work, large and small, and in this class of work there are, as a rule, usually but two kinds of metal wanted, viz., frictional and anti-frictional, *i.e.*, soft and hard. The question may be asked, *Can* castings be poured with one mixture only, that is, with either scrap or crude pig? Our answer is a qualified affirmative, but the life of such parts as cylinders, slides, and bearings would be comparatively short if they were cast entirely from pig iron of an ordinary kind, which, although fluid, is soft and unsuitable for anti-frictional castings. On the other hand, with a good scrap for machinery castings in the production of small engine castings, no one need have much fear. Jealously guard against using old pots, pans, pipes, and hollow-ware scrap in the production of polished castings. Such can only be judiciously mixed for casting goods with unpolished parts, although they may do fairly well where only a *facing* or some such machined part of a casting is necessary. If the pipe scrap happens to be thick it is likely that fluidity will be high, because these goods, as a rule, are cast with metals containing a high percentage of metalloids. As to cylinder metal prepared under the conditions indicated, some of the best cylinders we have ever seen bored were castings in which metal was taken from the scrap-heap dumped down in the foundry yard. However, we do not recommend the take-it-as-it-comes method, even to experienced men. A good cylinder metal can be mixed from brands suitable for general machinery castings. Equal parts of Derbyshire and Scotch, with about one-fourth of hematite melted and run into pigs once or twice, can be recommended. Again, one may make a local selection of similar brands to those mentioned, which, with a small percentage of

white iron and a judicious proportion of cold-blast, will, when mixed, melted, and run into pig moulds, make a very superior metal for cylinders. But of this there is no end. Every cylinder expert claims to have some secret either in mixing, melting, or temperature; indeed, the best cold blast specially smelted for cylinder metal, according to these people, is inferior to their own. Be that as it may, experience admits of no such thing as crude pig metal being safe and suitable for the casting of cylinders of any description.

In a foundry where loam work is done, the metal as mixed for cylinders can be used for casting building plates, rings, and core irons, and then broken up after they have done the work for which they were intended, and used for the casting of cylinders. The saving here will be obvious, and we have as much confidence of success in this plan of preparation as in using the metal mentioned after it has been run into pig moulds as a preparation for cylinder castings. It is an old foundry saw which says that it takes a bad cylinder to make a good one. However, carefully selected scrap, or a special preparation as has been stated, is indispensable.

Other engine castings, such as slide blocks, slippers, slide valves, and bearings, may be poured with equal parts of scrap and pig, but if poured with cylinder metal, so much the better for the life and usefulness of the castings. Engine castings other than those already mentioned are usually cast with a mixture of three of pig iron to one of scrap, or half and half of these two metals will be found fairly suitable, even when "runs" are somewhat lengthy, such as is usual with ordinary engine sole plates or bottoms. But no hard and fast line can really be drawn here, because circumstances alter cases. No. 1 Scotch is recognised everywhere as the greatest friend the founder has in restoring fluidity to scrap metal, but an indiscriminate use of it has frequently proved it to be the founder's foe as well. Many founders favour it not only because of its graphitic nature, but because it is a strong iron, and is low in shrinkage. It is, however, a dangerous metal if poured at too low a temperature, as the graphite has a tendency to separate as kish, and in this way does much mischief. Its bad effects come out most prominently in the

points of the teeth in spur and pinion wheels, and other extremities. With a mixture of graphitic iron and scrap, approximately on the lines described, much depends on the speed of pouring, the temperature of the metal, and the gating, which last is an important and vital factor in the pouring of all metals into moulds.

Agricultural Castings.—This class of work, such as plough-shares and breasts, is sometimes cast in chills, while other foundrymen make good castings in sand. Of course these must be very hard, and for that purpose a small percentage of white iron to each charge in the cupola is an advantage when mixed with scrap and pig iron. In the moulding of these castings, without chills, a high percentage of coal dust mixed in the facing sand is necessary; this and a good coating of blacking dusted on thoroughly sledged moulds are factors in improving the castings. Whether agricultural work as suggested is cast in iron chills or sand moulds, hardness is the essential feature to be aimed at and secured. If no white iron is added to the mixture, whatever it may be, then the moulder, by his treatment of the mould on the lines suggested, can do much to bring about the desired effect; in addition, he may work the facing sand as damp as safety will permit.

Of course a good deal depends on how castings are treated to produce hardness compatible with safety. The man of experience may have results from selected scrap quite superior to those of another who has everything in the way of selected brands, grey and white, to mix from. White iron, hematite, and cold-blast need not be considered essential, for more than good metal is required to procure good castings. All men are not qualified alike for tempering a steel tool in the smithy, and so in like manner, at least to a greater or less degree, it is with men in the foundry as regards results in tempering castings.

Again, chills for this class of work are not always all that could be desired, as cold-shut veins at times appear, and so disfigure the casting. To obviate this trouble some common rosin may be ground to a powder, and shaken through a bag as if it were blacking. A small amount on the face of the chills will flux and render fluid the metal which runs over the

face of the chills at the time of pouring, and thus improve the face and finish of the castings.

Grey Metal and Steel Mixture Castings.—Of metals suitable for constructional work, cooking ranges, firebars, and such like, not much information of special value can be given. Practically everything depends on ordinary grey foundry iron judiciously mixed with scrap. A good scrap iron is much better for firebars than an expensive graphitic iron, whose refractoriness is considerably less on account of the excess of fusible elements it carries. It is worth noting that the life of a firebar is extended by being cast in "open sand," although firebars made in that way may not be so good-looking as flaked bar castings.

Figs. 40, 41, 42 and 43 are intended to show the difference in fluidity between irons of an anti-frictional and frictional grade. Fig. 40 represents an anti-frictional mixture whose poverty in fusible constituents makes it unsuitable for running moulds of this section in the horizontal position. The bulby formation of the metal, as it rises over the top of the core into the space shown unfilled with metal, is suggestive of cold-shut.

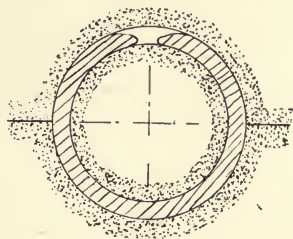

FIG. 40.

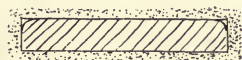

FIG. 41.

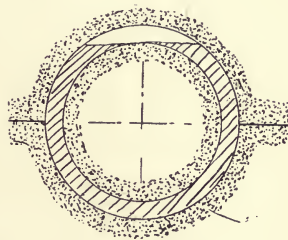

FIG. 42.



FIG. 43.

This is due to the natural lack of fluidity of this class of iron, and possibly also to a decrease in the original fluidity caused by surface oxidation as the metal fills the mould. Defects like these in many cases, or indeed with cold-shut generally, never appear on the surface, and, as referred to elsewhere, because the skin

is complete, nothing but the hydraulic test generally can disclose them.

The round edges of Fig. 41 are the result of want of fluidity similar to that represented in Fig. 40, both being due to poverty of what some are pleased to call impurities. I confess I do not like the term, as these elements are essential in giving fluidity, and the absence of them would make cast iron a product almost, if not altogether, useless in the art of founding in general. When, however, castings are subjected to excessive heat or to the action of acids, brands of the nature described and indicated in Figs. 40 and 41 will give satisfaction.

In Fig. 42 it will be noticed that the casting has a perfectly level surface which indicates first-class fluidity without the bulky surfaces shown in Fig. 40. As these two surfaces meet at the top (Fig. 42), they completely fill the mould, and the meeting of such, we may rest assured, will result in a sound and homogeneous casting, such as would be impossible with the metal used in the other case (Fig. 40). Fig. 43 illustrates what in plate form would most likely be obtained from the same mixture, *i.e.*, sharp top edges. Thus the metal that suits one class of pattern will also suit the other. A mixture for Figs. 42 and 43, or all such sections of metal where fluidity is of first-rate importance, should be made from grey brands judiciously mixed with scrap from similar metal.

One of the best anti-frictional metals in iron foundry practice is to be got from a mixture of steel or malleable scrap with cast iron, the latter in the proportion of two to one, but in no case must the proportion exceed this. Fifteen per cent. of malleable scrap mixed with ordinary cast iron will densify many poor brands, and produce for certain purposes a metal equal to some of the best brands in the market.

This mixture is somewhat of a "fake," and has long been recognised by many as "semi-steel," no doubt because of its superiority to ordinary cast iron. It is capable of doing good work, wherever used for gears and anti-frictional castings, but, being dense, is very liable to draw; therefore the gating must be about twice as large as that allowed for casting or pouring ordinary iron.

In melting this mixture prepare the bottom of the cupola with about 25 per cent. more coke than is used for common cast-iron melting. The first charge on the top of this should consist of scrap and pig-metal from brands for ordinary machinery castings. This melting first dribbles on to the hearth of the cupola, and so prepares a suitable fluid bath to receive the malleable iron which is mixed with the scrap or pig composing the succeeding charge or charges of the melt in the cupola.

It will be obvious that more than usual care is required for the mixing of this metal. Therefore, whatever be the amount melted, it should be tapped into a ladle large enough to hold all the metal melted, no matter whether it be by one or more taps, and thus procure the best mixing possible. Of course the best results obtainable with this mixture are got by preparation and casting into pigs, as was recommended in the case of first-class cylinder metal.

TEMPERATURE

The importance of this question not only to the founder of high-class castings, but to those whose work has not to undergo the same close scrutiny, can scarcely be over-estimated. Temperature and its effect on the coarser grade of castings is really worthy of attention, since with good management its control involves no extra cost of production.

It is not my intention to deal here with the subject of pyrometry, or the measurement of high temperatures with the aid of instruments of a high degree of sensitiveness, but to consider only the control of temperature by the observation of the trained eye. Colour is thus used as the indicator of temperature, and it is only necessary to dip the feeding rod or other iron rod into the fluid contents of the ladle. This method, as with any other requiring experience, necessitates a long training before one is able to determine temperatures, but in the absence of a simple and reliable instrument for foundry purposes an iron rod is a good substitute. The simplicity of estimating temperatures by merely forcing a rod with the least possible disturbance into the metal in either

ladle or crucible is apparent, and the author has used this method to his utmost satisfaction for many years.

Many have but one idea of temperature, and that is to cast moulds with metal as hot as it is possible to produce it from the cupola. This is unlikely to give satisfaction unless with rainwater goods and those cast from metal of a highly graphitic or phosphoric character. Although these brands of iron may with safety be cast at a white heat (for the class of castings usually poured with these metals), the same temperature would be dangerous with hematite or cold-blast irons. There are in addition many other conditions which determine the correct pouring temperature, such as the character of the mould, whether chill, dry sand, or green sand; and the faculty of being able to judge the most suitable temperature for the pouring of a mould is one of the most important factors in making a successful founder.

Having thus indicated the necessity for the careful control of the heat of the metal previous to pouring, it will be well to consider next some of the results arising from the lack of any such control, and the condition of the mould before pouring; and I hope to show that it is best to cast always at the lowest temperature compatible with general conditions of safety.

Then, as to the first of these items, it is known to experienced men that when iron of the most metallic brands reaches the milky-white heat it is in a boiling and disturbed condition and altogether unsafe for general casting, and more especially is this the case wherever the gate is in immediate contact with the casting, *i.e.*, where the heat is not reduced by travelling along to any appreciable extent before the metal enters the mould. Much of the evil done by using metal in this state never comes to light, unless it be the rougher skin produced by casting with too hot metal, and because of the fact that much of it is cast in the form of hollow work and general architectural castings, etc. But when we leave this class and come to machine-finished and polished work and that which has to be hydraulically tested, the regulation of temperature becomes of the utmost importance. Many are the instances which might be given, but Figs. 44 and 45 should suffice. Fig. 44, which shows the end view or flange of a barrel with

arrow pointed at gate, and Fig. 45, which shows the part in immediate contact with the gate, may serve to illustrate what I believe to be the effect of excessive heat, and which is caused by the continual action of the metal on this part of the core at the time of pouring.

Clearly, if this be so, it must follow that the greater the heat at which metal is used in casting a job of this description, the more intensified will the defectiveness as shown at Fig. 45, become. What this figure demonstrates has, in my experience, proved a source of trouble no matter wheresoever encountered, and as often as not was explained by a shake of the head, or some such utterance as the usual "I do not understand." But moulders who do understand, even if they have no other position of casting and gating, will be able to reduce this intermittent evil to a very appreciable extent by a little stratagem in

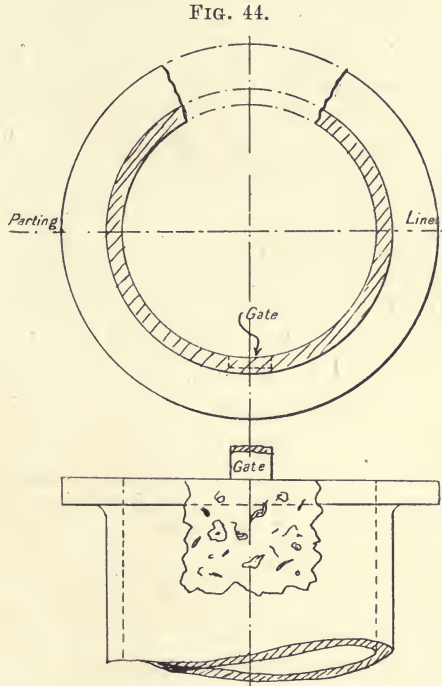

FIG. 45.

the formation and size of the gate in question, and run a good chance of securing a faultless bore in such castings. The defect as illustrated at Fig. 45 invariably conceals itself until the boring bar, with its cutters, passes over this part at the time of machining. The holes, as illustrated, sometimes confine themselves to less space than shown here, and in other instances occupy more space than a man's hand could cover. Their depth is usually about $\frac{1}{4}$ in. to $\frac{3}{8}$ in., and not infrequently

these holes contain a small ball or pellet clinging as tenaciously to the side of the defect, as illustrated, as a limpet does to a rock.

Doubtless there is room for difference of opinion as to the cause of this nasty effect which has been the means of consigning to the scrap-heap many an otherwise good casting. But, as the result of lengthy experience and careful observation, I have come to the conclusion that it is really a case of "blowholes" caused by the continual rush of metal on this particular part of the core, which is practically the mouth of the gate to the mould. This rush of metal prevents the free escape of gases evolved from this part of the core, and there is a tendency for some of the gases to remain entangled in the metal, giving rise to numerous small blowholes in this part of the casting, as illustrated at Fig. 45.

Castings run as indicated should at all times have their gates distanced, and designed whereby the least possible "boil" of metal will take place in the mould, and if cast at a temperature judiciously cool will give the best results possible.

Mould Conditions.—The characters and conditions of moulds have also to be reckoned with in fixing the temperature at which any mould should be cast. For instance, there is variety of thickness, which is always a source of annoyance because of the variation in solidification and shrinkage. The thinner metal certainly requires the greater heat, and as thickness increases, temperature, generally speaking, decreases. Therefore, where variation of thickness exists a mean temperature ought to be struck, which is generally fixed at the lowest temperature suitable to the safe running of the thinnest parts of the mould.

In deciding the temperature for dry-sand work—and what is said under this head may be safely applied to loam also—the first thing to reckon with, as in green-sand work, is thickness; and if the moulds have chaplets interspersed among the cores and the castings are to be tested hydraulically, the higher the temperature at which such moulds are cast the better will be the results. There are, however, other conditions to be considered, of which the drying of the moulds is perhaps the most important, as the following will show.

Fig. 46 is an illustration of what in the foundry is known as a "dumb scab" due to defective drying. Wherever this occurs it is caused by the action of steam generated by the heat of the metal. This steam accumulates in the face of the mould, forces its way through the surface and causes the defect shown in Fig. 46.

It will be observed by the practical man that some little time must elapse, in most cases, after pouring before steam can develop and work its way towards the surface of any mould. This admitted, there is safety in working for rapid congelation, *i.e.*, other things being equal, for by doing so we reduce the time the metal must take to set, and may thus secure a good casting even from imperfectly dried moulds, which at all times are to be dreaded. But to put it more

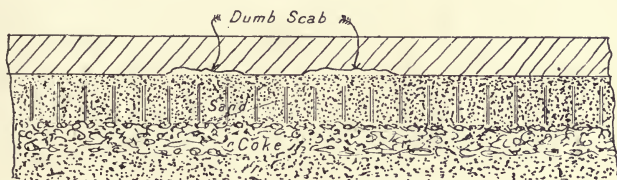

FIG. 46.

clearly, and by way of example, metal at a comparatively milky-white heat used in the pouring of moulds should take approximately double the time that metal at a pale orange heat would take to solidify. Therefore, if circumstances permitted the using of the latter condition to pour at, it must be manifestly clear that with the shorter time, fluidity is likely to be past and solidification completed before steam could generate and reach the surface, with its damaging effect, as shown with the double arrows at Fig. 46. Hence, moulds that are doubtfully dried should only be cast with metal at a temperature as low as it is possible to take it, and with due consideration for all other points of safety in securing a good, sound and solid casting.

DEFECTS IN CAST-IRON CASTINGS

The causes of the defects so frequently found below the surface when finishing iron castings have been made the

subject of much discussion in technical literature, and many theories, often wide of the mark, have been advanced. Wherever defectiveness appears, whether a spongy surface or irregular holes, the popular verdict is dirt, and caused by dirty metal. Such conclusions are usually the result of inexperience, and in the writer's opinion, the majority of defects below the surface of castings are due to bad design, badly adapted metal, or neglect in the matter of feeding and position of casting. Within the last few years a very rapid advance has been made in foundry technics, especially in the United States, and it would seem as if the future would see a chemist in most of the better conducted foundries throughout the United Kingdom. This cannot but be an advantage, but it must always be remembered that chemistry is not intended to replace but to increase the value of practical experience gained in the foundry. No matter how well adapted metal may be for any given job according to chemical analysis, it cannot give sound and solid castings if the details of moulding and casting and the after-treatment as directed by the foreman be not all that is necessary.

Defects in cast-iron castings may be due to unsuitable casting position, *e.g.*, whether vertical or otherwise. Any mechanic with a junior understanding knows the importance of casting "face down." In the author's experience of casting rams, which is considerable, there never was any trouble with the bottom end being defective, and the same is true of all other similar castings when cast in a vertical position; indeed, any practical man with a knowledge of castings, seeing a ram for the first time as it came polished from the turnery, would have but little difficulty in determining which was the lower end of the casting, as the top end invariably shows to him a more or less speckled surface when finished. This speckled surface is caused by the impurities, which are the lighter constituents of the body of the metal, rising to the highest part at the time of casting. Defectiveness would be more pronounced were one foolishly to attempt to cast a ram with No. 1 grey iron, as there would be such an accumulation of graphite at the top end as to make the metal altogether unsuited for the

purpose intended, and this would be more so if the metal happened to be rather dull at the time of casting.

The question may be asked, Is it necessary that rams should be cast in the vertical position? To this the answer is "Absolutely so," and no good is likely to come from attempting to cast in any other position. In order that this may be more easily understood, a ram as it should be cast is shown in Fig. 47, where *A* is the top end and *B* the bottom. A ram cast in any other position than this is not likely to give satisfaction. The author has known of rams giving way while working under tensile stress at the points indicated by the line at *B* (Fig. 47), the reason being that this part was not solid on account of being the top end at the time of casting.

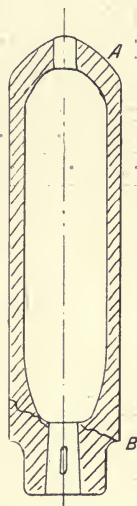

FIG. 47.

It is common to apply a "sinking-head" as a cure for this evil; but unless it be of considerable depth, it is reckoned by many to be of little account. Some authorities proportion sinking-heads at 1 in. per foot, but the cost of cutting those sinking-heads off is considerable, and has its proportional outlay in the foundry also. Therefore, by stratagem and experience combined, it is possible to have no less satisfactory results, if not better, without the aid of the sinking-head, as mentioned, and this has been proved to the author's satisfaction in practice. All considered, the foregoing confirms the advisability of casting the plug end *A* up, with this type of ram, (Fig. 47), as the plug end has but little tensional strain while working. Therefore the greater proportion of graphite, and other dirt accumulated, is not of a serious character, while pouring at this end is not likely to give any troublesome results in the life of the casting. Moulders, as a rule, prefer the cotter end *B* (Fig. 47), to be the top end while casting, as they have a dread, and not without cause, of the cotter core going to pieces on account of the long drop the metal has to the bottom of the mould. A cotter core at this depth is almost

an impossibility for the fettler to get out of the casting, because of it being metalised by such extraordinary heat and compression; therefore the better way is to cast the end solid, and bore and slot the cotter hole, which gives greater satisfaction to the foundry, and proves itself a better job for machining, with no additional cost in this department.

Fig. 48 shows the back cover of a cylinder as it is sometimes cast; such a casting is generally defective round that part to which the arrow points. The metal as seen at the arrow, being badly arranged, results in a dirty-looking casting, the turner being unable to get the polish on it desirable. At first sight to many this defective surface looks to be dirty metal, it being so badly speckled on the surface; but a closer examination reveals the fact that it is porous owing to badly proportioned metal in this particular part of the casting. This porousness is quite visible all round in the region of the arrow, and

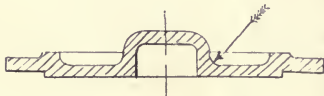

FIG. 48.

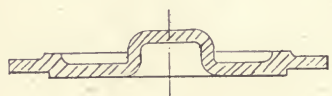

FIG. 49.

at times the writer has seen it so bad as to condemn the casting, this part being considered insufficient to withstand the cylinder's working pressure.

Fig. 49 explains how to obviate this evil. In this figure we have a well-proportioned design, and it requires no great practical understanding to observe that immediately on casting such a mould, the process of solidification begins over the whole body at one and the same time, and with ordinary metal suitable for machinery castings, and cast at the right temperature, the textural homogeneity of this casting may with perfect safety be said to be complete.

It will be noticed that Fig. 48 represents an error of design. Many other instances might be added in which the blame is undeservedly borne by the foundry. A mastery of design, as where to put on metal and where to take it off, would in many of the best established engineering concerns save much time and money.

Figs. 48 and 49 are used to illustrate the difference between good and bad design, and to what extent density is affected thereby. Moreover, as a consequence, the casting is first condemned for sponginess round the part pointed out by the arrow (Fig. 48), and second, because of its non-dense and dirty-looking surface. But it must be borne in mind that it is not the outcome of dirty metal as the common verdict would make it, but is caused by an error of design, and, as a matter of fact, neither iron smelter nor founder have anything to do with it, although the latter, as usual, would have to account for it. This defect or trouble, shown at Fig. 48, is just another form of shrinkage; the rest of the casting has set previously to the part exposed by the arrow, as before mentioned, and has drawn therefrom. The defectiveness is not visible to the casual observer before polishing, and but for the skin being destroyed in the process, would undoubtedly have passed muster as a good casting, but the scrutiny of polishing condemned it.

The lesson here, for moulders and engineers alike, is to seek a clear understanding of the habits of metal in all its phases, for with it much of the success of engineering and mechanics in their broadest sense depends. Attention to this point will make defective and bad castings a diminishing quantity, and will also make the foundry of the future a better and more profitable place for all concerned.

SPECIAL PIPES (AND PATTERNS)—GREEN-SAND AND DRY-SAND

While standard straight and bend pipes have long been made by special equipment in pipe factories, we still have to mould the "specials" much on the same lines of practice as did others fifty years ago. Indeed, it has yet to be seen whether our methods in this sort of work can be improved upon. No doubt means to an end with "special pipe moulding" vary, one shop vieing with another as to which is best and cheapest. One may have a "boss," another a skeleton pattern, and the latter being capable of a very wide interpretation means anything but a standard pattern in wood.

A "boss" is usually run up on trestles in the same way as a common loam core; some incline to finish the core, with the exception of blackwashing, then add on the thickness of metal with a course of straw rope and loam which is usually sufficient to finish the boss; but we get all the better job by leaving space to finish off with a second coat. This, when dried and painted with tar, makes a very superior "makeshift" pattern. In point of fact, tarring of a "boss" enables it to be used repeatedly, if need be, and at the fourth or fifth time should leave the mould more intact by being thus protected than is usually the case with a "boss" used for the first time without tarring. Tarring the boss should not be done without sufficient heat to absorb and quickly dry the tar.

But, on the other hand, where two bars can be got for boss and core it is much better to run these up separately. This method entails no appreciable extra cost, and gives a guarantee for a safer and stronger core. In the first process of "core and boss" combined, it will be seen that both in cooling the boss and ramming the mould, the materials, straw rope and loam, are put to too severe a test for the core finished previously to be handled with safety at the time of casting. The foregoing method of using substitutes for patterns can only apply to spherical and parallel types of pipes in general.

Special bends, U and S pipes, are most economically produced from skeleton patterns. A skeleton pattern is usually made from a flat board $\frac{3}{4}$ in. or 1 in. thick, and need only be dressed in the pattern shop on one side to admit of easy and clear drawing off of the job. When this is done, it is cut and finished to the outside diameter, and should have 5 ins. or 6 ins. extra plate beyond the end facings of the casting, in order to allow sufficient length for core, and core bearing, when moulding. With the plate pattern in this condition (Fig. 50), core plates and core irons should be cast before any more work is done with it in the pattern shop, otherwise it may be imperative to make an independent plate pattern, for casting plates and core irons of the work in question. At the same time while the above applies to heavy and light pipe castings, we need not hold too rigidly to cast-iron plates for sweeping

up the cores, as the following experience in moulding an S pipe will show:—

Moulding an S Pipe.—The five figures (Nos. 50, 51, 52, 53, and 54) illustrating the moulding of this pipe represent a steam pipe (for a “breakdown” with no available pattern at hand) 4 ins. diameter, about 3 ft. long, and shows all pattern pieces necessary for the moulding of the job.

The first notice the foundry had of this pipe was about

FIG. 51.



FIG. 52.



FIG. 50.



FIG. 53.



FIG. 54.

9 a.m.; and plates having to be cast for sweeping up the core in halves, it was generally admitted that the pipe in question could not be cast that night. But here the foundry manager interposed by saying that if they departed from the usual practice of making cast-iron core plates, and substituted wooden ones for a time, it was quite possible for it to be cast with the first of the metal that afternoon, which was about 3 o'clock.

This was agreed to, and two core plates as shown in Fig. 50 were soon produced. These were cut from $\frac{3}{4}$ -in. wood by the aid

of the band saw, and dressing was unnecessary. The core maker having secured these plates in wood, along with the sweep (Fig. 51), a piece of rod iron suitable for core irons was soon obtained and set to the centre, as shown in each half of the core at Fig. 52, so that in about an hour's time these half cores were swept, placed on an iron plate for protection while drying, and the stove being in prime condition to receive them, they were thus dried for jointing in about as short a time as was taken to make them. The jointing being completed, the core was taken back to the stove, and thoroughly dried, then carded and calipered to size, was tried in the mould and finished by being blackwashed, which necessitated its being taken back and put in a place suitably heated in order to drive off any water absorbed in the process of blackwashing.

The core being now completed and ready for the moulder's convenience, the goal was practically reached in so far as the surety of casting a pipe of this description in the least possible time was concerned.

Now, there being nothing extraordinary about the moulding of this pipe, further than that which is common to all "skeleton" pipe work, we need not spend time as to details thereof. Pattern Fig. 53, is rammed, parted and drawn, and it is then simply a case of scraping out to gauge, with the sweep (Fig. 54), and the better or more experienced a man is in this sort of work, of course, the better will be his results. It is the fewest number that excel here, because, unless a man has an eye for the artistic and an understanding how to firm and form a mould, with a due regard to "ferro-static" pressure at the time of casting, just as likely as not we get a casting of a rough and irregular form due to swells, strains, etc. Suffice it to say, this pipe was cast to a nearness of the time promised, and was in due time lifted and fettled in a dull red state, and passed into the machinist's hands for facing the flanges before 6 o'clock that night, the pattern pieces being delivered to the foundry about 11 a.m. We thus see that the time occupied from the beginning to the end of the job was something like seven hours' working time, clearly saving a full day's time by substituting "wooden core plates" for iron, and with no appreciable increase in the cost of production.

While we admit that there are other methods and "fakes," in moulding a pipe in a hurry where no pattern for the moment is obtainable, still there is nothing I know of that can excel for speed the method just described.

The practice of sweeping up a core and drying it, then sweeping on it the thickness of metal, as is sometimes done, is, in the author's opinion, not good practice. For whether it be by sweeping in halves and jointing after the fashion of Fig. 52, or should it be a boss run up in the usual way of core making as previously referred to, in neither of these ways have we a substitute for a pattern capable of withstanding the force of ramming that is necessary to procure a good casting. Because, no matter how careful one may be, the core first formed must become deteriorated by the force of ramming, and the frequency of expansion and contraction caused by using it first as a boss to mould from, and second as a core in producing the casting. Then as to time there can be no comparison, because, with the former method, as illustrated by the five figures (Nos. 50, 51, 52, 53, and 54), which admits of the moulder and core maker moving together, no overlapping of the one with the other can possibly take place; consequently the job proceeds without a hitch or stop of any kind from start to finish.

Briefly put, the second method means that the core, after being swept, run up, or completed, has to enter the stove for drying, and when taken therefrom the thickness of the metal allowed for the pipe casting is swept or coated with loam on the core. It is then put back in the stove for drying, and when dried with this thickness added it will be obvious that some time must elapse before it can be sufficiently cooled, etc., and the moulder can with safety use it as a pattern. Again, after it has been so handled and taken from the sand, it has to be stripped of its thickness of metal before the core can be restored to its original condition, thus causing an amount of expense and trouble which seems too apparent for further comment. Thus we have tried to show two methods of making the same pipe, first by skeleton pattern, second by the boss method; and by adopting the former for pipes similar to those dealt with here, the mould should be

completed and ready for casting in less time than is required to prepare a boss for the initial stage of ramming a special pipe on the lines laid down. And although this is but a small job in special pipe moulding from a skeleton pattern, the principle is the same throughout (with the exception of the wooden core plates) with all pipes, large or small, that are thus moulded.

Moulding an Air Vessel with Boss Pattern.—In Fig. 55 we show a “boss” for moulding an air vessel, say, from 6 ft. to 12 ft. long, which, as has already been stated, consists of straw ropes and loam run and rubbed on a core bar, as seen in longitudinal section. It will

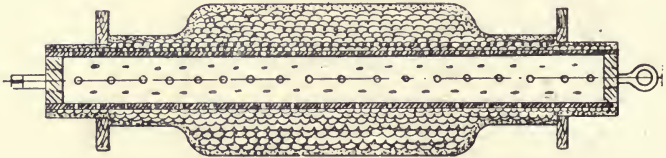

FIG. 55.

at once be seen that a wooden pattern for such a job as this means in money three or four times what should be the cost of the casting from the foundry. But with the use of a boss, tarred as previously stated, the saving all over is very considerable indeed where only one or two are wanted.

At one time it was common for such a job as this to get a pipe pattern as near the diameter at one or both ends as possible, and make what was called a “skeleton saddle” to fit over the body of the pattern, thus forming the bulge or body (not illustrated). This method gives a good deal of trouble in the foundry, and means considerable cost in the pattern shop also. With regard to the work entailed in the pattern shop, the least that probably would be done to make the saddle suggested would consist of a few circular pieces to indicate the outside diameter. These attached to three horizontal bars made from full drawing given, and of the requisite breadth for “faking” of the pattern, with a due regard for correct

diameter, constitute the outline here given of a "saddle fake" to a suitable pipe pattern for a "makeshift" pattern for an air vessel. Circle parts may vary from 6 ins. to 12 ins. apart. These two half saddles for the respective halves of the pipe pattern selected, and for obvious reasons not illustrated, should give a fair idea of what is wanted, and at the same time show the work of moulding from such to be considerable in the foundry, as will be seen from the following.

First of all, when the moulder gets to work (*i.e.*, in the method of turnover boxes) with such a pattern as this, he has to fill with sand all spaces on the saddle, and ram, form and finish the outside diameter, the saddle being his guide in this operation. After being formed, the whole body must be lightly coated with wet parting sand, and sleeked, thus enabling the mould to part from its sand boss, which is a part of all skeleton pattern making.

In finishing moulds such as this we must also have sweeps supplied for all the different diameters to prove thoroughly what is necessary before the final finish, and so secure the true dimensions wanted. In summarising this method of moulding an air vessel, as illustrated at Fig. 55, the work of the pattern shop consists of making the saddles for both halves of the pattern selected. These, with the loam board for the core and sweeps to prove the body, all combine to form a considerable sum in the cost of producing this casting.

Compared with the above the cost of the "boss method" of moulding is very trifling in the pattern shop, as a core board for the boss and a loam board for the core are all that are required in connection with the body of the casting. And the flanges and core board being the same in both methods, we are left to put the cost of the core and loam boards against the cost of the two half saddles and sweeps for the pipe-faked pattern. So that for every shilling spent with a boss in jobs of this description we may spend as many sovereigns in faking a skeleton pattern of any kind.

Hence it is that wherever time can be allowed for the making of it, a boss as a substitute for a pattern will, wherever

practicable, give most satisfaction. We have used this in casting columns where only half-a-dozen were wanted and with every satisfaction. When painting or tarring the boss, the latter being preferable, a mixture of equal parts of tar and creosote will penetrate considerably further than tar by itself, and the boss becomes much harder thereby. This and the anti-clogging nature imparted by painting with the mixture mentioned make it a comparatively good pattern for leaving the sand when drawing it previously to finishing the mould. No scraping or faking, such as belongs to the skeleton pattern method of moulding (an item of considerable cost), attends the method of moulding by a boss.

Making an Air Vessel Core.—A glance at Fig. 56 will show that much more care and ability than is commonly needed

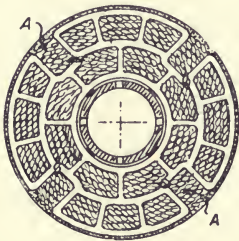

FIG. 56.

in making straight pipes is required to make an air vessel core of the dimensions given here. A special core bar to some may seem imperative, but this is not necessary. Any ordinary parallel bar of suitable diameter for either or both ends (allowing from $1\frac{1}{2}$ ins. to $2\frac{1}{2}$ ins. a side for

“coating”—the former preferred) will do. It may be said that there is no great or unusual danger with these cores, even when the bulge or body part is 9 ins. a side larger in diameter than any of the end sizes of this core. But in order to make it strong enough rings are cast suitable for wedging or keying on the bar.

By reference to Fig. 56, which is a section of the body of this air vessel core, we see at once the idea of fixing these rings, shown in section, to the bar, and without them this core would be very unsafe if not altogether useless for casting this job horizontally. Such an amount of ropes and loam as is shown in section (Fig. 56) require to be interspersed with rings thus shown, say, from 15 ins. to 18 ins. apart, of course beginning from one end and finishing at the opposite end.

The rings of design shown at Fig. 56 have four slits (*A*) so as to admit of the core maker getting his ropes on uninterrupted from end to end for at least the last three or four courses. This is important; and if he also works his ropes alternately from the opposite ends he will add materially to the efficiency of such a core as Fig. 56 represents.

Drying the Core.—Much care must be exercised in firing this core. "Slow but sure" must be the motto, so that all may be dried to the point desired without burning or "tingeing" the ropes in any way. Nevertheless, it must contain that amount of moisture necessary to maintain the strength of the core and its resistance to pressure, and at the same time be sufficiently dry to keep it from blowing at the time of casting. These are factors of vital consequence which nothing but experience can direct or command.

It is not at all times the safest way of judging a core as to whether it is dry or not by the amount of steam it gives out from the ends of its bar while drying. The better way of educating oneself in this department of core making is to drive a $\frac{3}{8}$ -in. spike right down through the core to the extent of touching the core bar. This done, allow it to remain a few seconds, and when drawn the amount of dampness shown on the spike represents the condition of the core internally. This and sound, by rapping the core all over, should be regarded as the main principles of determining as to whether a core, and especially of this class, be dry or not.

Bottle-Necked, Bell-Mouthed, Tapers, Branch Pipes and Bends.—The above are but a few of the pipes in general use and must all be regarded from a jobbing point of view. In designing these pipes the first concern of the draughtsman should be economy in pattern making and moulding; and if these two departments be considered in this matter, machining and fitting, we may take for granted, will work out in the cost of production much the same, irrespective of methods adopted in pattern shop or foundry.

Fig. 57 shows a bottle-necked pipe whose diameters varies from 20 ins. to 16 ins. respectively. With this pipe we can get many sections with results practically the same in so far as

efficiency or capacity for work is concerned, as we shall show. First, then, we have it as shown in the figure mentioned; second, the same capacity of supply is produced in Fig. 58, and again we can have the same in effect from a common tapered pipe not illustrated.

Tapers.—Now, of the types mentioned it will be generally admitted that the tapered pipe must have a preference, because of the uninterrupted gradation that admits of the easiest flow of liquid or vapour of any kind through it. But while the core of this pipe can be quite economically produced the same does not apply to the mould, and the absence of taper pipes in the foundry goes somewhat to prove this contention. Nothing is more troublesome to “scrape,”

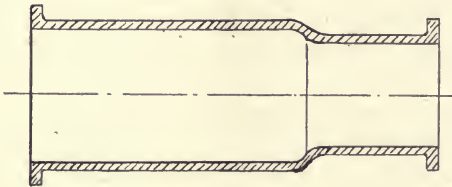

FIG. 57.

cut and finish to size than a sand mould for a tapered surface or section, which no doubt accounts for the absence of this design in diminishing pipes. Conse-

sequently, where a taper pipe is imperative and no pattern be available, by all means make this pipe with a boss, or sweep it according to “special” pipe foundry practice; other things being equal, it will be cheapest and best in the end, when only one or two are wanted.

Bottle-Neck Pipes.—But to return to Fig 57, which shows a “bottle-neck,” the different diameters being previously given. With this pipe it will be seen that the amount of work in the pattern shop is considerable, and this is intensified when passing through the foundry in the process of moulding.

At this point it ought to be mentioned that all these pipes are to be taken as 9-ft. lengths, and it should also be remembered that moulding boxes made for pipes do not usually give more than 3 ins. a side for sand, but sometimes less. So for every inch added to the diameter of a pipe we require a correspondingly broader moulding box to mould it in, thus

increasing the time to be taken for moulding and drying the job. Those two items of cost are worthy of serious consideration, and militate against the adoption of "bottle-necked" design where diminishing pipes are wanted.

Bell-mouthed Pipes.—In Fig. 58 is shown a "bell-mouth" straight pipe, 20 ins. by 16 ins. diameter. This pipe can with perfect safety be substituted (especially for water and steam) for a "bottle-necked" pipe, and in choosing this way of making a diminishing pipe we see at once its simplicity, as also its economy.

Now, assuming we get a pipe pattern the diameter of the small end, namely 16 ins., the fixing of the largest flange on the "bell-mouth" end need not count for much. And, as a matter of fact, the "bell-mouth" can be formed in the foundry by the aid of two joint bracket-like pieces 3 ins. thick. These, and one similar, top and bottom, fixed against the flange and resting

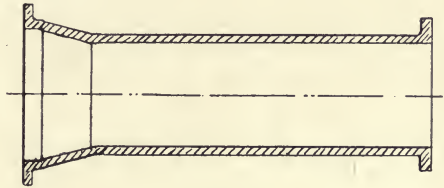

FIG. 58.

on the body of both halves of the pattern, include all the pattern making required for moulding this or similar "bell-mouth" pipes. The amount of "bell-mouth" as illustrated at Fig. 58 should suffice for bolt holes and brackets on the flange, if the latter be desired.

One of the principal factors in economy in moulding this pipe is to see that the ordinary moulding boxes for 16-in. pipes will admit of the flange and "bell-mouthed" end getting into the head of the moulding boxes in question. If this be not obtainable, the result will not be quite so satisfactory. Nevertheless, the economy of moulding a diminishing pipe on the lines suggested should commend itself throughout all departments interested. Of course, a special core board to suit the bell-mouth in this job, as with the other types referred to, must be made. The saving of time and material from every point of view and an equal capacity for work and efficiency make this at all times an ideal diminishing pipe.

Branch Pipes.—The placing of a branch on the side of a pipe may seem a very trifling affair to many outside the arena of practical moulding, nevertheless its bearing on the cost of production is no small matter indeed. In its best form it means not less than double the cost of a straight pipe, and at times it may even treble this, and may not figure two dozen pounds more in weight. It frequently happens that in this class of work, and especially when dealing with small diameters, the costliest castings passing through a jobbing foundry are within the limits of cost for small branch pipe castings. This is even the case where the condition of patterns is most favourable, *i.e.*, being in store, together with all appurtenances, such as flanges, branches, bearings, and templates—things common to jobbing pipe foundry practice.

In arranging branch piping, the one important point for the foundry is to make all branches from the side of the pattern as short as possible, and more particularly if the pipes be of large diameters and lengthy. Due attention to what is here suggested means money in the foundry; and if dry-sand be the order for casting, the importance of keeping branches at a minimum of distance from the body of a pipe cannot be over-estimated. While this is so, it has to be admitted that circumstances arise which give the draughtsman but little, if any, choice in these matters. Still it often happens to be the other way about, and until there be more give and take between drawing office, pattern shop, and foundry, much useless waste in the production of castings, as hitherto, will continue to go on.

The pattern shop generally comes in for a fair share of the wages spent in “branch pipe moulding” (pipe factories excepted), even with shops that have standard length and short pipe patterns favourable to the casting of branch pipe work. But with branch pipe moulding, as with other kinds of work, there are more ways than one of doing it. Some fix everything on the pattern that goes to make the casting; others do this but partially, and leave the moulder to bed in all branches to sketch; while on the other hand some foundries are only supplied with sketches, the pattern shop supplying all adjuncts which go to make the casting

to sketches, thus leaving the responsibility with the foundry in producing "branch," "short lengths," and variable lengths of bend pipe castings. The last method is as free from liability of mistakes as the system of fixing on everything to sketch in the pattern shop. Of course the foundry cost is a trifle increased, but this method, and the saving it effects in the pattern shop, may give a good profit on a job, which otherwise might mean considerable loss.

In moulding branch pipes by this method, the moulder should "bed in" the neck flange, which is usually a tight fit with the pipe pattern. These rammed and cleared off give a grand base and make things quite clear for measuring, and bedding all other parts that may be shown on the sketch that he is working from. The body flanges for jobbing pipe founding are best when fixed on a 3-in. or 4-in. circle belt of flat iron about $\frac{3}{16}$ in. thick. This flange makes easy and safe working, and if once placed and well rammed, with the body of the pipe rammed previously, no fear of shifting need be apprehended. The pins fitted with these flanges make it perfectly safe to hold the top half in its position also, assuming the flanges to be in good working condition.

Bend Pipes.—In this section of the pipe trade it may be quite safe to say that more ideas in practice have here been demonstrated than with any other casting we can think of. From the solid pattern, skeleton and boss, to the machine method of moulding and casting bend pipes, there is a truly wonderful amount of thought and genius involved in this branch of founding, every detail of which has an importance of its own. And to go to extremes we can at once say with safety that a machine-made bend pipe, in so far as moulding is concerned, has nothing whatever in common with a hand-moulded bend casting. But this aside, the various methods of hand moulding give a range greater than is necessary for our purpose, at present, of casting bend pipes on the lines of a jobbing foundry, to which these notes on special pipes (although limited) are directed. Therefore, whatever excellent methods are adopted in pipe factories for turning out these castings expeditiously, and on the basis of standard or repeat moulding, the question of how to make a bend of ordinary dimensions, when only one or two are wanted,

is what these short articles are primarily intended to deal with. And while admitting the principles of skeleton pipe moulding, large or small, to be very much the same, it goes without saying, that the details must differ according to circumstances. Fig. 59 is a stool bend, and gives us an example in this respect, and the details given are applicable to bends from, say, 18 ins. to 30 ins.

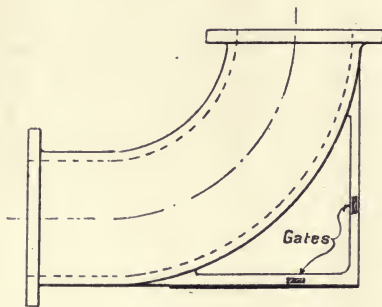

FIG. 59.

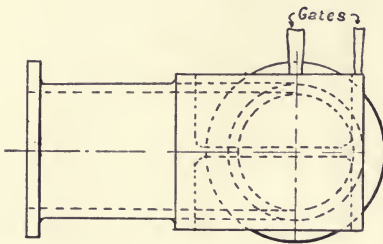

FIG. 60.

diameter. With this class of castings, and where plant and other conveniences are commendable for dry-sand and loam moulding, these will be cheapest and best when moulded in either. So much for this detail in "heavy bend moulding and casting."

In proceeding with the stool bend (Figs. 59 and 60), suffice it to say that the principles of drawing and making the skeleton pattern are all to be found in the making of an S pipe (Figs. 50, 51, 52, 53, and 54).

Core Irons and Cores.—

Having thus assumed the principles of moulding to be matter-of-fact, we now touch upon some of the essentials in making the core irons and cores of the stool bend under consideration. In the first place, we call attention to Fig. 61, which shows a plan of the core iron, and bottom half of the core, as seen in complete section at Fig. 62. In this figure special note should be taken to observe that the eye thus, Ω , in the top half of section *B* (Fig. 62), is cast into the core iron, also shown. This eye, or "lifter," in the plan (Fig. 61, *A*), is represented by dotted lines, showing where to place it for convenience of slinging the core when handling it during the process of making it and coring the job. This

eye, and the projections at both ends of core iron *C* (Fig. 61), make good slinging provision for cores of this type. Consequently the eyes, as shown in Figs. 62 and 63, are of vital importance to the slinging of this and similar large bends and loam cores. This kind of core iron is superior to anything we know of for this class of work, and with the strong sectional bar, or "backbone," running through the centre and the ribs projecting therefrom, the core-iron should be comparatively light, and thus facilitate and make fettling an easy job for the dressers. The dotted lines (Fig. 61*A*) show the formation that the top core-iron must have to admit of the "eye" getting up through from the bottom half of the core. If this be not attended to the arrangement as shown here will be a failure. One "eye" (not shown) should also be cast on a suitable part of the top half of the core, and on the curve of same, for slinging this half of the core preparatory to jointing it.

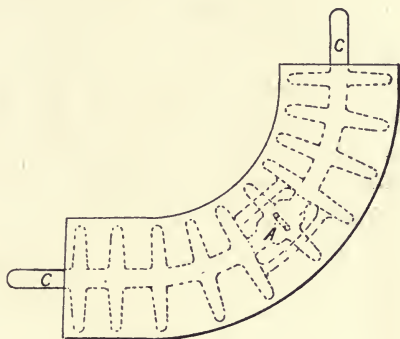

FIG. 61.



FIG. 62.



FIG. 63.

Fig. 63 illustrates in section the bottom half of the core, as it lies swept on its plate *A*, and is intended to show conclusively this important point to greater advantage.

It is not necessary to mention here other kinds of core irons, except to say that these are all stamped and moulded with a shovelhead; or if a thicker section be advisable, a sledge hammer may be used for this purpose, and when stamped they are then faked up or finished with a flat stick or trowel, according to foundry usage in this class of work. The prods, or daubers, as seen in both sections of Figs. 62 and 63, are formed by curving a spike of malleable iron for this purpose,

and a little care in daubing these irons with the curved spike in question, for more reasons than one, will serve a good purpose. Further, standard bend core irons, wherever it may be possible to fettle without breaking, can be made with "wings" instead of prods as illustrated (Fig. 62). If "winged" core-irons be preferable, then a pattern of some sort should be made.

Gating the Mould.—It is always matter for concern to know the best place to run, or gate, a mould, and frequently is this the case with jobbing pipe moulding. However, in Figs. 59 and 60 the stool of this bend is so well situated that nothing could beat it for this purpose, and "dropping" anywhere from the stool should do. By this way of gating we get the hottest metal passing over the top side of the core when it rises to this level at the time of pouring, and at the same time it will clean the top side of the casting considerably, which will go a great way to obviate blistering as well. Moreover, when casting or pouring pipes in the horizontal position, if provision can be made for a hot ladle of metal getting in by a flower or riser gate to wash the back of the pipe mould, so to speak, the greatest good possible will result in securing a sound casting. Top sides, wherever practicable, should be exposed for examination in a comparatively red condition, for improving, if that be necessary, what is cast. The least possible time spent on this operation, and again covering up as quickly as possible, is very desirable.

Again, the importance of standard lengths of bends asserts itself here, and were this recognised things would be better for all concerned in this class of jobbing founding. Just one case in point. A large bend, say, 24 ins. diameter by 7 ft. 6 ins. by 2 ft., according to sketch, whose extreme measurements would approximate 9 ft. by 3 ft. 6 ins., with an additional 6 ins. lengthways, and a little more than this sideways for core bearings, and with also the usual average for depth of flange, would, therefore, involve the use of a monstrous box in which to mould such a pipe.

Now, with a "knee," or quarter-bend, such a pipe as above referred to would never be sketched, as the same could be got from a knee bend of 2 ft. by 2 ft. and a straight-

length pipe of 5 ft. 6 ins. long. This arrangement for pattern making, founding, etc., and the *phenomenal reduction of moulding*, make it the workshop practice of experience as it should be, and avoids the loss which inevitably follows inexperience in every phase or form of workshop practice.

Pump Pipes.—In concluding this short section on jobbing pipe founding, our purpose has been to a considerable extent to bring the drawing office, pattern shop, and foundry together; and in order to emphasise this and the difficulties common to many young draughtsmen, “pump pipes” will be more pointedly advanced in the interest of the drawing office as a whole. True it is in many instances that we find men, with large experience and worthily holding first-class appointments, who have never been in touch with a foundry at all.

It is likewise too true that many excellent draughtsmen know not the most elementary parts of moulding. Of course, that is their misfortune, doubtless due to circumstances over which they had no control. Therefore, in view of these facts, and all the circumstances relating thereto, it is to be hoped that our efforts on the lines suggested will at least in some small way bring the foundry nearer the drawing office, and thus assist the young and inexperienced men, for which this short treatise is specially intended.

It has come within the writer's experience to explain in a general way the *modus operandi* of moulding many things, but nothing seemed to be more difficult of comprehension to the uninitiated than the moulding and casting of a pipe. All seemed to grasp easily the outside or formation of the cope, but the difficulty of making the core which forms “the hole,” as it has been put, or internal diameter, seemed to be the stumbling block to all.

Pump pipes, as a rule, give but little concern in moulding, but to the engineer they are a vital question, and so these should all be tested hydraulically, to at least double their working pressure. It will be observed that the flanges, as shown at Fig. 64, are bracketed. Some engineers hold these to be indispensable to pumps and pump pipe flanges, while

others maintain the reverse. The objections are based on the flanges being weakened, by spongy parts about the brackets, which are filleted in touch with the flange. Such, undoubtedly, is the influence of all brackets that are on flanges, and is caused by internal shrinkage after casting. But this evil has its remedy, and the principle of bracketing flanges need not be condemned wherever they are wanted or are imperative.

Ordinary piping, where the flanges are normal and work in the horizontal position, have no particular need for brackets, so long as they are well filleted, and are not subjected to abnormal knockings or strains while working. But, on the other hand, if pipes have to do their work vertically, as in the shaft of a mine, where the unexpected frequently happens,

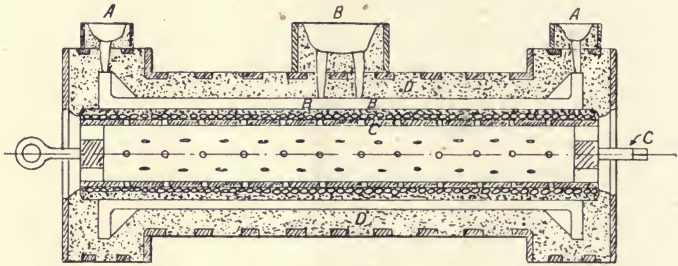

FIG. 64.

brackets will hold the flanges to the body of pipes in a way utterly impossible without them. In short, brackets are indispensable adjuncts to pump pipes where a strong and secure flange is wanted. The same applies to flanges that are of abnormal dimensions, both for safety of handling during manufacture and transit, not to mention their efficiency for duty afterwards. Doubtless brackets give a little more trouble to the founder, and in some cases it would perhaps be better to place a bracket between each alternate hole, instead of one between each hole in the flanges.

Again, and to return more particularly to what concerns the moulding of the job, in Fig. 64 everything is seen in position previous to casting horizontally, and a study of this figure will make clear to the uninitiated the whys and wherefores

of pipe moulding. As will be seen, *A A* are the riser basins, *B* the pouring basin, *C* the core bar and core complete, *D* the mould as formed in the moulding box. With such a view it will readily be conceded that not much more need be added by way of explanation, in so far as moulding a pipe on jobbing lines is concerned, because to the practical moulder there is little to give here, and to the non-practical, presumably, it would be less interesting to narrate how a pump pipe is moulded, further than to say that it is a dry-sand mould that Fig. 64 is intended to represent.

But the question may be asked, Could it not be cast in green-sand? The answer to this is an affirmative one. Although to mould "pump pipes" in green-sand is not a desirable thing to do, still, if circumstances compel one to do so, it can be done, although at greater cost as compared with dry-sand moulding. Many have just the one idea of classing and pricing castings, as, according to their standard, loam is the most costly, dry-sand comes next, and green-sand is the cheapest of all.

This, although the most popular way of looking at prices in general, does not hold good in every case, and "pump pipes" are an exception to this rule. And no person, generally speaking, can satisfactorily cast pump pipes to pay in open market competition or give general satisfaction to all concerned unless by dry-sand or loam moulding, which may be resorted to with some of the larger diameters by streakling or sweeping in similar boxes to the dry-sand ones when a pattern is not procurable.

Core Making.—As is commonly known, the core is made up of two "coats," the first composed of straw rope and black loam rubbed on to the straw rope, and calipered to the size wanted. This being dried in the oven or stove, it is then taken therefrom, put on to the trestles again, and receives the second coat of loam, and made to finished size. The second coat, known as "red loam," being made from river-sand, with a judicious portion of clay. The core, being thus finished to the size wanted, is again run into the oven, dried, and after being blackwashed and again dried, is ready for use. This is somewhat summarised, but a study of Fig. 64 may convey to

those outside foundry practice at least some of the information wanted.

Position of Casting.—Again, in referring to Fig. 64, it will be noticed that it shows the horizontal position of casting. Some may suppose this to be a mistake, but, instead of this being so, it can be proved to have its advantages over the inclined or “declivity” position, which some engineers maintain to be the ideal way of casting pump pipes.

Fig. 65 is but a skeleton sketch intended to show the “declivity” in casting to be something like the angle of 35 degrees, which is the most popular position in which dry-sand pipes are

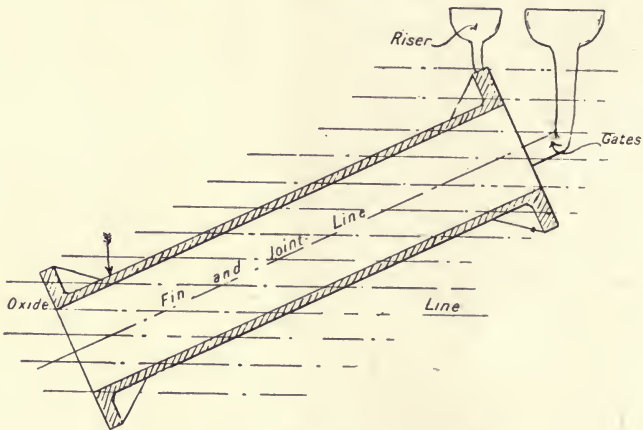

FIG. 65.

cast. But although this is so, the losses through “cold-shut” are much in excess of any other position, and the curious thing about it is that cold shut is more liable to be at the bottom end, in the region of the arrow, Fig. 65, than any other part of the casting. This may be surprising to many, as owing to the fact of the bottom end having the greatest pressure, we naturally expect this part to be more dense, and thus give greater security for its ultimate test hydraulically.

We might at this juncture make a slight digression, and explain what cold-shut really is. Briefly put, it means a

meeting of metal in a mould from either point of the compass with a film of oxide of iron floating in front (see Fig. 40), and wherever a meeting of oxide-laden metal takes place, the two surfaces of metal, although forced together with great pressure, will not unite, with the result that the metal is here divided as distinctly for all practical purposes as it is possible for it to be. Obviously these surfaces can have no affinity for each other, neither are the defects seen on the surface, but when broken up cold-shut in metal is as prominent as a knot is in a piece of wood. "Cold-shut" and "cold-shot," although synonymous in foundry practice, and produce the same effect, are due to different causes which need not be considered at present.

But to return to Fig. 65 and follow, with the mind's eye, the fluid metal poured into the basin, and the distance it has to run before it reaches the bottom flange, it will be seen that this cannot be done without an accumulation of the oxide of iron, or kish and dirt, gathered on the way. This admitted, Fig. 65 is lined to illustrate as well as may be the effect produced as the metal rises in the mould at the time of pouring. Special note may be taken of the greatest oxide line (see arrow, Fig. 65), as it is at this point that the greatest evil is created by this mischievous element in metal, which is the cause of many defects in all classes of castings. This is seldom seen to the naked eye, and, where no pressure or strain is involved, as a rule does but little harm.

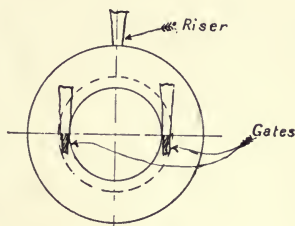

FIG. 66.

The only way to avoid cold-shut on the declivity position of casting pump pipes or similar piping is to cast with the softest of iron, and at a milky white heat. Even in this way you can never be sure of success, because not infrequently the kish gets caught in the "joint," and if it remains there a cold-shut in a greater or less degree inevitably follows. But, after all, were the trouble of declivity casting not as depicted, this position, I hold, is the most favourable way of pouring,

and where circumstances favour no other position see to it that, as mentioned, soft iron is used whose fusible contents are high, and cast at as great a heat as will suit all points in connection with the job.

But should Fig. 64 be adopted, there is little or no danger from oxidization, which means no cold-shut, as the oxide which is floating on the surface rises on both sides of the core alike (see Fig. 64), and meets at the top right in touch with the pouring gates (*B*); it is here cut up and destroyed, and assimilated with the hottest of the metal. But should any of it have perchance escaped assimilation, there is every likelihood of it finding its way into the riser basins *AA*, Fig. 64, which doubtless receives much, if not the whole, of the dirt, which otherwise would have become incorporated with the metal right along the highest part of the mould. Some may imagine there is great risk of the core scabbing by casting as shown at Fig. 64, but the writer has not found it so. Given good loam and a thoroughly dried core, made by a good core-maker, success is practically assured.

Fig. 66 shows the position of the gates when the pipe cast on the declivity position or "the bank."

CORE CLIPPING -

With many moulders the act of clipping a core is not an easy matter, and even some good sand moulders are not quite comfortable in this operation when perchance they may have to undertake the "clipping" of a branch core for a pipe, valve casing, or some such casting having a branch detached from the main core. Of course, when there happens to be a run of such work requiring "clipped branch cores," core boxes, which form the "clip," are usually made, and by this means the moulder, if inexperienced in clipping ordinary branch cores, is saved a good deal of nasty work, and just because of this a hint or two may be the more serviceable where such practice has been neglected.

This question, from an engineer's point of view, means much for the future of those castings that are exposed to

waters which contain the elements of rapid corrosion, because of the broken skin inside of the casting at all times associated with the "clipping" of cores, as seen at Fig. 67. Broken skin inside a casting is a two-fold evil to be avoided as far as it is practically possible; first, because of its susceptibility to corrosion, and second, because of its tendency to weaken the particular spot affected, and when thus affected the tendency to "sweat" while under the pressure of the hydraulic ram becomes considerably intensified. Consequently, the moulder in making such castings should always work for the least possible internal "fin." This, as a principle in casting work that has got to be hydraulically tested, is worthy of the moulder's serious and best attention.

As will be observed, the foregoing applies in a special degree to heavy castings, and if they be pumps, the smaller class are usually cored by one complete

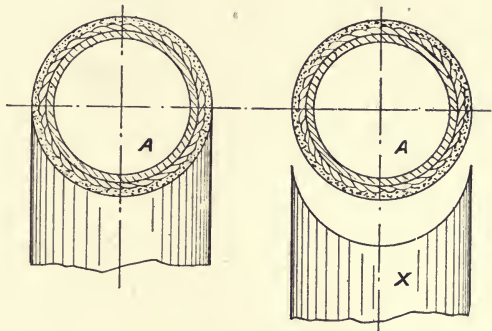

FIG. 67.

such cases we see that the interior of the casting throughout is entirely free from "broken skin," and, other things being equal, becomes an ideal pump from every standpoint.

Having now made clear the difference that exists between pumps or such cylindrical castings that are clean and clear from irregular fin and "broken skin" inside, we shall next treat of the different methods that may be adopted, and which are the most suitable when circumstances compel branch cores to be used in the "core plan" or arrangement of cores in a mould.

Perhaps the term "clip," or "clipping," is a local one in the foundry, and in order to make it the better understood, as the term is applied here, it is those points of the branch core as

illustrated at Fig. 67 that the term is derived from—hence we form the “clip branch” to fit up against the main core, *A*, Fig. 67. There are three ways of clipping, and to each of these we direct attention as they appear at Figs. 67, 68, and 69. Figs. 68 and 69 are illustrations showing the advantage of the “swell,” *SS*, which is on the main core of all cores that are clipped as illustrated by Figs. 68 and 69. In Fig. 67 we have the usual way for the moulder to adopt as it involves no trouble further than forming the clip on the core. This, however, means more than some jobbing moulders are capable of doing in workmanlike fashion, while, at the same time, it is bad in price and practice, whether the core is made in sand or loam. If it should be a sand core that is to be dealt with, then, by all means, form the clip while it is green; but if it be loam with which the branch core is made, the usual practice is to make it out of the solid core by carding or otherwise, until the desired finish for fitting it-up against the main core is secured, as seen at Fig. 67. However, there is still another method, and a speedier one too, although to some perhaps not very workmanlike. Still, it is in many ways commendable. The first thing to do is to square, in some way, the end of the branch core preparatory to proceeding to put the “clip” on; thereafter place a sufficiently large piece of paper over the back of the main core for whatever size of clip we may wish to make; then, with the core thus prepared, sufficient loam is placed on the paper, and the branch core is immediately placed on the main core, and squared on this bed of soft loam, and by “faking” and firming all round the “roughing” of the clip is completed. This being done, all is allowed to stiffen, and when finishing it, make sure that the points of the clips as seen at Fig. 67 are finished clear to admit of the branch core being placed without breakage while finding its way up against the main core of the mould for which it is intended.

Now as to the results in this method of clipping: First of all, there is the danger of the points being washed away during the process of pouring the mould, and second, we are confronted with the evil of a nasty fin at the clip of the branch which must be broken and “faked”—not chipped, as the

position precludes any possibility of doing so—but, although faked thus it is, after all, the best that can be done, and the fin so treated is allowed to pass as a finished job. This then is what happens with branches in general that are clipped after the fashion of Fig. 67. The longer the branch the more difficult is the job, nevertheless wherever this method of clipping is practised the best fettlers can do no better than what is here suggested.

Why this practice is allowed to go on in many of what are called up-to-date shops is not easy of explanation, yet, if the person responsible for the foundry has not a full appreciation of what particular duty is expected of the castings passing through his hands he will be content to knock the work through, irrespective of all other considerations but his tonnage in the foundry. It

goes without saying that in these hurry-scurry days of push and bustle, better methods of economical working and superior workmanship are lost sight of altogether. Hence it is that at times money is lost in the foundry that need not be if the moulder had the

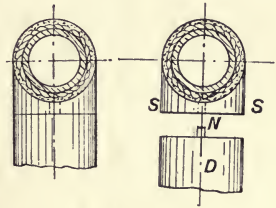

FIG. 68.

knowledge of what to order, and the pattern-maker had the will thereafter to make what are frequently but trifles for the expediting of the work of the moulders, and its consequent saving and better castings for all concerned. This job of clipping cores is really a case in point, and specially as it refers to the saddle core-box, not shown, for ramming the clips on the back of the main core, and as illustrated at Figs. 68 and 69. In these Figs. *SS* shows the core clips either built on with loam or rammed with sand, either of which is done when the main core is finished to size, and thereafter allowed time to stiffen. These clips as a rule when being rammed are strengthened or supported by sprigs, brads, or irons driven into the main core and otherwise handled in the way common to such cores.

With a clear view of Figs. 68 and 69 (double), along with what has been stated, the meaning and value of such a

method of clipping, as illustrated by the figures in question, will doubtless be obvious, inasmuch as we avoid the danger of the points (*v.* Fig. 67) washing away. In connection with this point we see at once that the joint, as it occurs through *C*, Fig. 69, can be made an absolute fit, thereby getting a clean and clear inside skin on the casting, when the branch core is butted fair up against the main core face *SS* (and is ripped, repaired and blackwashed if need be). However, this is not often resorted to, as these branch core joints when carefully manipulated have such a small fin, and from the handy position they occupy on the branch when compared with Fig. 67 no

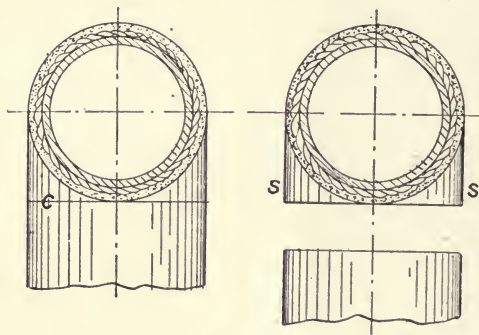

FIG. 69.

difficulty whatever is experienced in chipping and finishing an unchallengeable job. This method is more particularly adapted to the heavier class of branch core practice; the lighter class in this division of work is provided for and

illustrated at Fig. 68. In this figure the practice is to all intents and purposes the same as Fig. 69, the only difference being the plug end. As will be seen, with such a core as this sectional elevation shows, when placed in the mould, the branch *D*, with its plug end, is simply butted up against the face of the figure referred to. The plug branch as shown is for the safety of the core against rising at the time of casting, and the plug being comparatively a tight fit in its socket secures the branch from other mishaps common to such class of work, no nails or other artificial aid being necessary. Briefly, we summarise the clipping of branch cores thus: adopt Fig. 68 for all diameters up to 6 ins., Fig. 69 for all other sizes above 6 ins., and wherever the method of Fig. 67 is practised, then the

least that can be said about it is that it is bad and profitless practice for all concerned.

MACHINE AND SNAP FLASK MOULDING

It is difficult to say exactly when machine moulding was first introduced in founding. Some would have us believe it to be quite a modern invention, but, on the contrary, we have been more or less associated with it for the last thirty-five years, and during all that period nothing very new or novel has happened to its mechanism. Indeed, it seems we cannot get past the ordinary squeeze or force produced by steam, pneumatic, or hydraulic pressure, and while hand-ramming was strongly denounced twenty-five years ago, it is now regarded by some machine specialists in these days as the most economical system of ramming in all forms of machine moulding. The foregoing as a rule is not without exceptions, and perhaps the best advantage to be got in machine moulding (if there be an advantage at all) is with a certain class of medium work that is executed by, it may be, thousands of tons, or that which repeats itself in the fullest sense of the word.

Certain it is, much that was put on the machine plate within the writer's experience has long since been scrapped, and a return made to the old stereotyped style of bedding in the floor, resulting in at least 50 per cent. saving with these castings when compared with the cost of production in what is known as machine moulding. The above refers to cylindrical work with attachments where no machine ramming by compression is practicable. However, where the plainest of work is moulded, that is to say, with patterns that are free from projections, or any attachment of pattern interfering with the direct force of the ram when pressing, such ideal work ought to be produced at a rate on the machine not possible off it.

It goes without saying that all machine work is repeat work. Now this is where many err in calculating costs in the foundry, and not infrequently when things look rather costly in this department they quite naturally turn to the moulding machine as a panacea for those evils of extraordinary cost. But, alas, for inexperience! such changes too frequently fall

much short of their anticipations. In all such cases look in the first place to equipment, and make it as good as you would that of a moulding machine.

Really it is largely a question of equity between floor and moulding machine, patterns and equipment, and perhaps it is not too much to say that wherever any piece of mechanism bears the appellation "machine," and yet, at the same time, has no record of reducing the physical toil of its operator, such has, in the author's opinion, no right whatever to be classed as a machine connected with the industrial pursuits. It is a pity that it is so, especially with founding, where so much abnormal toil is done. Further, it is very doubtful if more can ever be done by machines than is at present accomplished. Moulding as a craft has many peculiarities of its own, for, while form, contour, and efficiency suffices in most occupations, such is very far from meeting the wants fundamental to moulding.

Consequently, machine moulding such as is known in founding becomes very circumscribed in scope and practice, and as a result we may take it that the jobbing moulder will remain much in the same place in the future as he has been in the past, at least, in so far as mechanical aid in his business is concerned. But, on the other hand, he will have the advantage, as before, of outshining the machine moulder by the scope of his work which requires him to use his intelligence; and to this he should always aspire, as by doing so he will be the better man not only for himself, but for his employer also.

All the same, machine moulding, in the author's opinion, has come to stay, but we can only regard it as being a substitute with the "tub" or "bench" for small work, where plates and turn-over-boards are much the same as for machine moulding. Of course, with the machine we usually have the advantage of drawing the pattern or plate by a lever, and rapping it at one and the same time, which is undoubtedly an advantage in many cases.

It may be said that the machine has the advantage of grouping many pieces on one plate, but it should be understood that this same plate which accounts for so many castings in a box, as a rule, can be made as quickly off the machine as on it.

Indeed, where the boxes are a little unwieldy for lifting on and off the table of certain types of hand-ramming machines, in many such cases the operator prefers to make his job off the machine altogether and with better results for all concerned, thus proving that whatever increased output may be accredited to the machine in question is rather due to its equipment and not to mechanism at all. But whatever better side there may be to this question, we ungrudgingly give it, so that wherever machine and plant can adapt themselves to advantage by reducing cost of production, then by all means let it be done.

There is but little more to say on this question beyond the need there is for careful ramming in this class of work. All gates should be part of the patterns, and so save time in cutting them, leaving nothing to be done except prepare the mould for pouring. Use but little water* when swabbing patterns, *i.e.*, if the castings are light metals, previous to rapping and drawing; this will considerably free the castings from hard, brittle, and white fins and irregular edges. And should the castings be of light metal section, lift them the same day that they are poured, so as to prevent them rusting by lying too long in their boxes.

“*Snap Flask*” is a special form of moulding whereby any number of castings may be secured from the same moulding-box. This particular box, which is gripped and hinged at opposite corners, may be of round, square, or oblong shape, each of which is adapted for the greatest economy of sand and convenience in handling—two very important factors in the cheap production of the class of work for which the snap flask is intended.

This system has for many years been in much favour in light work foundries, where a large amount of work common to “bench” or “tub” was done formerly, and where the necessary plant formed a considerable asset, but by the introduction of one snap-flask box in the day’s work of each moulder on this class of work, instead of ten, twenty, or perhaps more, where each casting or box of castings had to count for the same number of boxes, the economy in plant must be obvious.

* Wherever this is practicable.

These boxes are made light and handy, and may either be made to work on the machine or off it. In every case these boxes are barless, but must have extra good "kep" in the form of say a half-inch projection running round the inside, top, and bottom of both boxes alike. In proceeding, first the drag is rammed and placed where it is to be poured; second, the top flask is rammed and closed on top of its neighbour. This done the mould is complete, is next planted where it is to be cast, and by the snapping of the gripper from its keeper the box is relieved and again prepared for repeating the operation of making another of the moulds just completed.

MOULDING CYLINDERS AND CYLINDER CORES

It is generally admitted amongst moulders that no class of work gives more trouble and annoyance than the casting of cylinders, not only from the intricacies which often accompany the job, but the general nature of it. From the time it comes into the foundry until cast and passed safely through the machinist department and hydraulically tested no one can be sure that his work is good.

Ramming.—Of course the natural beginning is the ramming of the job, after which will be considered other matters as they develop while working out the mould to the final stage of pouring. The ramming of the job is of the utmost importance in securing a good casting, and the moulder who thoroughly understands how to ram his work has gained the mastery of one of the chief points which help to make an intelligent and successful moulder. Certainly there is not so much danger in ramming a dry-sand mould as there is in the ramming of a green-sand one, but still, too much hard ramming will not do for dry sand, of which cylinder moulds are commonly made. Therefore, the surest and safest rule to go by is to ram as if it were a green-sand job.

Venting.—As regards venting it is not absolutely necessary that this should be done, except there be projections, or as they are commonly known to the moulder, "pockets," as the drying of the mould makes the sand so porous that the air passes quite freely from the mould without the aid of direct

venting. This and the expansion of the irons and gagers usually interspersed in dry-sand moulding make good venting, and especially is this the case with the top-parts, where hangers are usually hung on the bars of the box, which give free exit of the gases by their exposure. Needless to say, "irons" and such like do not make vents, but the effects from their use in dry-sand moulding give more or less the necessary space for relieving a mould of its gases at the time of pouring. This is brought about by expansion from the heat of drying the moulds, and when these are taken from the stove, the gagers or hangers previously expanded become considerably contracted previous to casting, and as a result the space for venting is thus formed. Another reason why dry sand does not require the same venting as is given to green sand is that by drying a sand mould at least one-half of its gas-forming constituents is destroyed, so between the former and the latter we see at a glance that venting of a truly dry-sand mould—unless there are projections as has been mentioned—is seldom imperative. Indeed, experience inclines more to "sprigging" and "ironing" judiciously than venting in dry sand moulding.

Sprigging.—This is very often overdone, but it must be attended to with discrimination. There is no necessity for sprigging unless it be to protect the mould or some part that may have started with the drawing of the pattern, and the better we "iron" a job of this class in ramming, the fewer sprigs will be used. This can only apply to cylinder moulding; that which is moulded and dried in the floor requires special consideration for itself which we cannot touch upon at present.

Finishing the Mould.—Finishing is one of the divisions in moulding where the man who is endowed with artistic instincts has an opportunity for showing his gifts. But it does not always follow that such men turn out the most beautiful castings. On the contrary, some men who are thus gifted make but very commonplace moulders, simply because the mind's eye has never been trained to read anything in foundry practice beyond the surface. A beautiful surface, and a symmetrically complete finished mould, may after all turn out a scab of a casting. Such completeness in form and beauty

may be the dominant factor of success in many trades, but it is certainly not so in moulding. The fundamentals to be secured which underlie the beauty of a well-finished casting are, first, efficiency of the mould to withstand *ferrostatic pressure*, and second, venting. These are the prime factors to be attended to before finishing a mould can be proceeded with in safety. Finished on the lines suggested, there is every chance of a good casting being the result in so far as those points referred to.

The moulder's first duty at the moment of drawing his pattern is to prove that his mould in every part is sufficient before he applies a tool to finish it. He must first firm, sprig, and vent, if need be, and when these are completed to his satisfaction, use the tools for the rest, but avoid polishing to the extent of hiding the grain of the sands, a mistake too often committed, and for which scabbing is most frequently accountable in green-sand moulding, and in dry sand, scaling and blistering, according to the position of casting. Horizontal surfaces are very liable to show these defects, while vertical surfaces are comparatively free from such danger.

Further, as soon as the pattern is "drawn"—and I need hardly say that the utmost care should be taken to secure a good "draw"—care should be taken to sleek down the joint, and to see that every part which may have started is put back into its proper place, so that when it comes to the "closing" of the mould, every part may be fair and free from crushing. Some moulders seem to think that because it is a dry-sand mould any amount of water showered on it before finishing is beneficial, but such is not the case. No doubt water is absolutely essential in making a strong mould, but if it is used indiscriminately so as to cause the mould to be glazed, the consequence will be that the black-wash will not adhere to it, and, as a natural result, there is every likelihood that the skin will be covered with black-wash blisters in the drying of the mould. It is thus better to avoid the free use of water; but if it be desirable to strengthen any weak part, a little put on after it is finished will do good, *i.e.*, if there is time for its complete absorption before black-washing.

But it is not my intention to treat in detail every minor

point relative to, or connected with, the making of the mould, believing that such would be of little value to the practical man and of less interest to the uninitiated. Hence it is unnecessary to treat at any great length concerning the working of the black-wash, further than to say that the drier the mould is before being black-washed the better, and likewise allowing it sufficient time to stiffen before being sleeked will materially assist in getting a good skin on the casting. Assuming the mould to have been black-washed with an ordinary mineral black-wash, the common practice is to rough-sleek, then dust with plumbago over the surface, and afterwards finish off. This done, a thin wash with plumbago made or mixed with either clean or gum water, brings out the best skin possible on a cylinder casting moulded either in dry sand or loam.

Core making.—The core maker, as previously stated, should be careful to avoid ramming too hard, as any core so treated is difficult to vent, and likewise difficult for the dresser or fettler to clean from the casting. He must also take particular care to have a good clear vent, as this is the all-important factor in core making, and must also be careful before black-washing to see that the surface of the core is entirely free from glaze, because there is nothing more dangerous in creating “blisters” on the top surface of a casting than a core with a glazed surface. The term blister as used in the foundry is a little ambiguous, because of the fact that no disfiguration, as is common to blister steel, or the formation of a blister anywhere else, has any similarity to a blister on a casting. A blister is a blowhole confined, as a rule, to horizontal surfaces, and may be any length, say from $\frac{1}{2}$ in. to 12 ins. long, and its greatest depth may be $\frac{1}{2}$ in. only.

“Blister” in foundry parlance is the term used to denote a surface defect that is formed by imprisoned gas which invariably is the result of a hard, dense, or glazed core, lying in the horizontal position. Blisters, unless broken by accident, do not, as a rule, show themselves unless by colour, or the sense of sound, to a practical man. The symmetrical surface of a casting usually remains the same with or without them, but when located, and the thin skin of iron which conceals

them is broken, invariably we find the surface which determines their extent to be as smooth as a piece of earthenware. Now in cylinder-sand core making there must be special care taken of the cores or parts of cores that have to occupy a horizontal position while casting, for, no matter with what pressure a core may be favoured, glazed surfaces must be avoided if we wish to avoid blistering, which is common to flat, or horizontal surfaces. See "Blowholes," Figs. 16, 17 and 18.

There are many who hold the opinion that this error, in a general way, is due to chaplets. No doubt a chaplet which is not clean and is corroded with rust will invariably have a bad effect; yet, after a careful and more than casual study of the subject, I believe that greater dangers arise from a hard and glazed core. The following is an example: I was once engaged making a class of cylinders which had a crown core, having from 2 to 4 ft. of surface, and as this core required no chaplets on its plain surface it may perhaps astonish my readers to know that I was very much annoyed with blisters. Various things were suggested and tried without success. Ultimately I tried "carding," or roughing of the surface, which had the desired effect and put an end to the annoyance. From this it must be obvious that blisters may be attributed to other causes than chaplets. Chaplets that are not clean should be burned, cleaned, oiled, or creosoted, and if this be attended to the most satisfactory results attainable should follow. See "Chaplets," p. 42.

Thus far the foregoing completes the moulding proper, in a somewhat summarised manner, and we will now treat of the closing and casting of the mould.

Closing.—This is, admittedly, the most intricate part of the whole job, and also the dirtiest part; but where cylinder casting is specialised, the moulders showing the greatest acumen in their craft as moulders are the men selected for coring, closing, and casting. Immediately on taking the mould from the stove or oven the moulder's first duty is to see that it is thoroughly dried before proceeding with the "closing." He should be satisfied that when casting it there will be no blowing from the damp which invariably gathers

in moulds that are not properly dried. But should there be urgent necessity to proceed with the casting in the face of such adverse circumstances, the mould should remain open as long as possible, so that it may be comparatively cold before the top part or cope is put on for the last time, because a mould with a great heat in it, and only half dried when closed in this condition, quickly generates steam, which condenses about the waste or hemp in the risers, and causes a great commotion, the metal bubbling and blowing as it fills in the riser basins at the time of casting.

It will be obvious that these remarks only apply to the smaller cylinders that are cored, closed, and cast in one day. Further, the greatest care should be exercised in securing the cores with the chaplets after the thicknesses have all been adjusted, which very often is the means of saving much time and trouble; for to unfasten a core that has been secured or jammed frequently ends in some part of the core being displaced or broken; hence the necessity of having the thicknesses all properly adjusted before finally jamming the chaplets. The next thing to be attended to is the securing of the vents, which cannot be too carefully done, as there is nothing more depressing to an honest working moulder than to see his whole work going to destruction before his eyes through lack of proper vents to allow the gases to get away freely from the cores, thus causing a bad casting which might have been saved by the exercise of proper care. With cylinders that have the steam chest or casing cast on them it is necessary for the gases from the steam and exhaust ports to pass through the heart of the casing core. The simplest manner of venting in this case is to daub the joints of the above with white or any other suitable loam; then clear the vents of the ports and exhaust, fill the heart of the casing with fine ashes, and conduct the entire vent through the joint of the boxes, or pass it up through the casing bearing in the top part by the aid of a suitable tube or otherwise.

This method of grouping all vents into one by the use of suitable ashes in the heart of the casing core, as explained here, and in "loam moulding," prevents a possible accumulation of moisture, which naturally follows the use of individual

vent pins that are sometimes used and rammed with sand in the heart of these casing cores. The ashes method of venting thus may be said to be absolutely safe, but the vent pins used as mentioned with the ramming of damp sand, is, to say the least of it, not good practice.

Position of Casting.—There is great diversity of opinion amongst engineers as to the position of casting cylinders; some prefer to have them cast vertically, or on end, others want them cast horizontally. The majority, I believe, favour the former position, maintaining that to cast cylinders horizontally causes dirt to stick about the barrel and create a faulty bore. But in the other position of vertical casting there is the common complaint of bad flanges on the top, or gate

end, of the casting which only comes to view when what is technically known as the sinking head is cut off. These imperfections are created during the process of solidification of the metal in the mould, which continues till the fluid metal is thoroughly set, the dirt, or scoria, common to the metal having found its way, at the

time of pouring, into the sinking head, the place specially designed for its reception.

These shrink cavities are always greatest on cylinders that have a disproportionate thickness, or parts attached to the top flange, as it is seldom, if ever, that a plain barrel of normal thickness, is thus affected. Now the best thing that can be done for this is to feed the casting as long as the metal is fluid; but unless provision is made for the feeders, the feeding will be useless, consequently the sinking-head must be made heavier so that it may be the last part to solidify, as shown in Fig 70. The advantage of keeping the sinking-head fluid until all the parts are set is apparent, as if it be thus kept fluid, and the casting fed, shrink-holes or such like will in a great measure be minimised, if not entirely removed in the case of cylinders that are cast on end.

Should disproportionate thickness of metal be confined to one side of a cylinder only, such as is the case with some

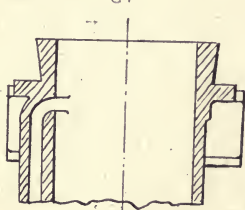

FIG. 70.

locomotive cylinders, and where the framing flange is on the same side as the valve face, make the face of the flange (which is the top flange) $\frac{1}{4}$ in. or $\frac{3}{8}$ in. thicker, and the extra thickness in the sinking-head on the disproportionate side only; the same to be tapered off in eccentric-like section. Having thus formed a heavier sinking-head as indicated, it admits of heavier flow-gates being made, which gates should be made practically as large as the thickness of the metal contained in the sinking-head will admit. And let it be remembered that the only preventative against cavities is compression and feeding well by some means or other. See to it that spongy parts as indicated by the arrows in Fig. 71 are in immediate contact with the feeder, otherwise such parts will undoubtedly be faulty, or the casting may be irretrievably lost.*

And now as to the horizontal position, which has many commendable features about it, although it is not without its troubles also. In this position we get the most perfect valve face possible, and valve rod paps uniformly solid, while the barrel

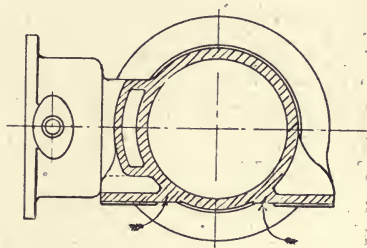

FIG. 71.

flange faces, which are so apt to give trouble to the vertically cast cylinders (top end only), are entirely sound and perfect. But with this position, as with all others, no matter how we cast, the dirt is always to be found in some undesirable spot, so in this case it is in the extreme bottom part of the barrel that all the trouble with dirt locates itself. This is worthy of note, because it mystifies many to find dirt on what they consider the bottom part of the barrel, as the bottom or face of all castings invariably turn out the most solid and cleanest part. But on closer examination it will be found that the top of the mould, paradoxically, is at this particular

* For some years some have adopted sinking-heads of abnormal proportions, these being anywhere between 1 ft. and 3 ft. in depth, and from 3 ins. to 4 ins. thick. Notwithstanding all this extra metal, shrink cavities at times appear on the "face" when the sinking-head is cut off.

place the bottom side of the core, a point which ought to be remembered when discussing the subject of a horizontal cylinder casting. In order to make this perfectly clear, it must be realised that the metal, collecting first on the extreme bottom, on rising comes in immediate contact with the core, and whatever dirt may be floating on the surface at this point has a strong inclination to remain there. Hence the difficulty of getting the barrels of cylinders perfectly clean when cast on their flat. Nevertheless, by adopting special methods of gating, the horizontal and declivity positions have long been the fixed practice of casting in some of the best locomotive shops in the kingdom. Some gate one way and some another; but there is one way of gating that should be avoided, and yet it is the most natural way in general practice—namely, to gate off the joint. Now to do this is undoubtedly bad practice, as the metal does not come in immediate contact with the bottom of the barrel at the moment of pouring, such as is the case with an admission gate at a lower part of the casting. Consequently a greater percentage of scoria is developed before the metal comes in contact with the bottom of the core, and as the pressure increases with the filling of the mould, this dirt or scoria clings more tenaciously on the part referred to, and by its remaining there, the hopes of securing a good casting are small indeed. This is a stumbling block to many, as has been said, as they maintain that all dirt, kish, or impurities must find their way to the top of the mould. Such is quite true, but it must not be forgotten that moulds of intricate design have more “top surfaces” than the one that is confined to the highest part of a mould. Moreover, we never saw a faulty bore on the extreme top side of a cylinder-barrel casting, when cast in the horizontal position; even although this part was not all that could be desired, the “bore” invariably turned out perfectly clean, all impurities escaping to the higher extremities of the casting.

Again it has to be borne in mind that many excellent cylinders have been cast vertically without the aid of a sinking-head at all, and such are the variety of opinions in foundry practice that he would be very bold who said that any position was supremely correct. But in moulding, as

in many other things, what may be lauded in one district is condemned in another ; this we may take to be the inevitable experience in foundry practice.

But, after all is said and done from a moulder's point of view, the details of pouring these castings must be of a very superior order. Apart altogether from the mixing and melting of the metal—which, of course, does not belong to the moulder who makes the job—there must be a clean ladle containing good and clean metal, well skimmed and cast at the right temperature, otherwise the best efforts made by the best moulders possible will be lost entirely.

Much mischief at times is caused at the start of pouring by dirt getting down the upright gate ; and it must be noted that this mistake is more dangerous in the horizontal than in the vertical position. But in casting in the former position, and in order to avoid this mistake, some try the plug gate for greater safety in pouring. The pouring basin in this practice has but one upright gate, which is plugged before starting to pour ; and after starting, and the basin being filled while the pouring is going on, the plug is withdrawn at the proper time. The pouring being constant, the job is expected to be cast without any dirt finding its way into the mould ; at least, such is the idea of some, and although it may appear a little Utopian to others, it is here and there in constant practice.

Writing from the standpoint of lengthy experience in moulding and casting cylinders for wind, water, steam, gas, and oil, and taking these in their broadest application as they relate to successful moulding and casting in the foundry, I say, as a principal, cast vertically and feed well. Of course, in the casting of cylinders there must be exceptions to this rule, but not with those that are jacketed, a class which, to do justice, requires to be dealt with separately.

JACKETED CYLINDERS

In this division of cylinder moulding we have all the cores common to the various types of cylinders, and the jacket core in addition, so that all jacket cylinders must in consequence be more critical to mould and cast than those cylinders that are

not jacketed. This class of cylinder is fairly well represented in steam, gas, and petrol engines. In some localities, when compared with twenty-five years ago, the jacketed steam cylinder casting is now almost a thing of the past. Happily for both moulder and mechanic, a better way has been found of forming the jacket in cylinders by the fitting into the cylinder body that handy article known as the cylinder liner. But the gas engine cylinder in general use is still cylinder and liner combined in one casting. The petrol cylinder of the motor car comes next with its complications and delicacy of jacket cores, which have given so much trouble to many, and have created difficulties that have been very hard indeed to overcome. These three different jacket cores will form the work of this division of cylinder moulding, notwithstanding the wide field of interesting cylinder moulding practice allied thereto, and what has been given in the previous section on cylinder casting makes it unnecessary to deal with all the details in jacket cylinder moulding.

(*Steam Cylinder Jacket Cores.*—These may be classed as of two different types—first, dry-sand cylinder moulding; second, loam moulding. When made for dry-sand castings, these jacket cores are usually made in halves, but when made for loam castings, they form, with very few exceptions, one complete core, and this is by far the safest and surest way of handling these cores. Jacket cores at their thickest seldom measure more than $2\frac{1}{4}$ ins. thick, even with the largest diameters of steam cylinders, and, of course, the thicker the core can be made the safer it is for the moulder.

(1) *Sand Jacket Core.*—When moulding a jacket cylinder in dry sand, the core, as has been said, is made in halves; one is fixed on the bottom half of the mould, while the other is fastened and hung firmly to the top part in such a way as to ensure absolute fixity without slackness or weakness of any kind, otherwise there is not a great chance of the casting being a good one. This procedure is necessary on account of the jacket core being entirely enshrouded in metal, and by fixing it thus, the plug cores on both ends of the jacket for venting and fettling the casting are all made good in this respect previously to commencing to core the cylinder as a

whole. The core-box for this method of working these cores is usually made of a shell type, *i.e.*, half circle, full length, and entirely open to the inside diameter of core. These half cores are better when made in loam, and should not be attempted in sand, where plug vents and the hanging of the core in the top part as described is imperative; but, if open entirely at one end, a sand core should do when the hanging of the top half of the core is not necessary. The sand suitable for jacket cores will be found in "core sands," and, if made in loam, that which is mixed for "pistons" will suit these cores also. The vents must be brought right up through the top when cast vertically, and should be made by bedding $\frac{3}{8}$ -in. round iron rods at suitable "divides." The loam should be tucked round the core iron in the box, and each core should be provided with a tube rigidly fixed to the core iron, hard up against the end of the core box, so that the plug cores, which are made with a tin tube in their centres, and projecting about an inch beyond the end of the core, telescope firmly into those of the jacket core just mentioned. The plug cores in the flanges should be placed so as to come in *between the bolt holes* of the flanges, and thus avoid confusion and the possible wastage of the flanges, which would mean the loss of the casting.

(2) *Jacket Cores in Loam Moulding.*—The difficulties and dangers connected with the making and manipulating of jacket cylinder cores in loam moulding are, of course, very great, and it is not too much to say that it takes a clever loam moulder with some engineering capacity to undertake successfully the carrying out of all the details in making these cores, and, before all could be fully explained, many more figures than the one employed, namely, Fig. 72, would be required to illustrate the *modus operandi* in full. Obviously this cannot be done, but it is hoped that the instructions given in Fig. 72 will suffice for those who may be specially interested.

Although the various methods of engineering these cores might be given, we shall only take the one thought best, no matter from what standpoint it be taken, and for that purpose let us keep in view Fig. 72 for our object lesson. This figure represents a jacket core in sectional elevation, with dimensions 6 ft. by 3 ft. by $2\frac{1}{4}$ ins. thick; and it may be said in

passing that the materials and workmanship, and all pertaining thereto, will answer equally well for cylinder jacket cores of larger or smaller diameters.

It should be stated that the building of jacket cores requires a special loam brick, made of porous river-sand loam. These

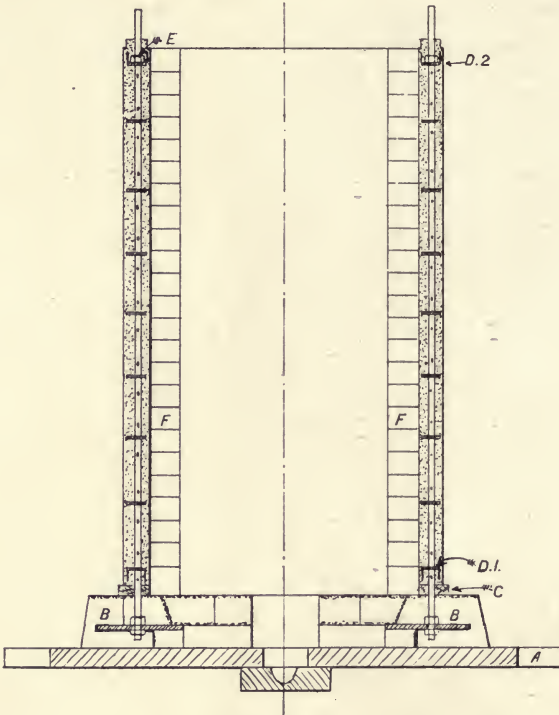

FIG. 72.

bricks should measure about 3 ins. by $2\frac{1}{2}$ ins. by 2 ins., and should have a small groove on one or both sides to admit the small hay rope which is inserted round every alternate course of loam brick during the operation of building these jacket cores. It must also be distinctly understood that these small hay rope vents in every second course must have their ends inserted right into the holes of the vent tubes prepared for them, as shown at Fig. 72.

In the building of jacket cylinders in loam there should be a circle plate about 6 ins. or 8 ins. broad, with holes cast in it all round "between the bolt holes of the flanges" of the casting. These holes are for the vent tubes (Fig. 72), which are screwed at both ends of the jacket core for binding purposes, as seen at Fig. 72, and the circle plate *B* of the same figure should be placed 7 ins. or 8 ins. from the bottom of the mould, thus leaving the brick in immediate touch with the base or bottom plate, and so give abundance of clearance to work the bottom nut, which secures the vent tubes to the circle plate *B*. The tubes in question serve the double purpose of core-iron standards, and vents, the ends of which pass up through holes cast in the top plate of the mould (not shown) for their reception, so that the projecting ends of the tubes as seen are shown to fit into whatever purpose of safety may be adopted at the time of casting.

The number of tubes in a jacket core can only be determined by circumstances, but to cast a hole on the bottom plate *B* (Fig. 72) for every second bolt in the flange of the cylinder casting, is good and safe practice, for, no matter how many holes we may use for tubes, such perforation as these holes form on the plate is all the better for venting purposes on the face of the mould. Besides, with so many holes, that in no case can do harm, we can scarcely be at a loss when arranging the tubes previously to building the core. In passing tubes through the plate for bolting, these tubes must have a double nut—that is to say, one on either side of the plate *B*. This arrangement of double nuts makes the tubes in question an absolute fixture, consequently no danger need be apprehended as to their shifting up or down. The distance of these tubes may vary from 12 ins. to 20 ins. on the circle of the core, and their distribution and number depends on the diameter of the respective cores. With the vent tubes which compose the standards of the core iron, rings *D* (Fig. 72) cast $\frac{1}{2}$ in. thick and $\frac{1}{4}$ in. a side less than the thickness of the core should be interspersed at a distance of every 6 ins. or 8 ins. while building the core in the vertical position. A pattern should be made for these rings, and holes cast in them suitable for the tubes to pass freely through in the process

of building the core ; and other small holes, over and above the tube holes, will be an advantage in the way of venting the core.

Thus far we have dealt with venting, and some of the materials requisite for making a vertical loam cylinder mould, but especially as it refers to the making of a jacket core for it. Having accomplished this briefly, it only remains to be said that jacket cylinder cores in loam moulding are all made from bosses, as shown at *F*, Fig. 72. These bosses are built with black loam and brick on the base plate of their respective jobs, as seen at *A*, Fig. 72, and are finished off with black loam, which soon stiffens, thus finishing the boss for its work of making the core.

The tubes being fixed as suggested, and the face of the mould being prepared for placing the pieces of wood *C* all round, which form the thickness of the flange, and the temporary flange being placed, we now proceed to build the core. By referring to Fig. 72 it will be observed that the first thing to be done here is to bed on the prodded ring *D* 1, and have it tucked up with loam as shown. This, being the base or foundation of the core, must be done in good workmanlike fashion, and thereafter proceed with the structure as mentioned, and illustrated in the figure. Special care must be taken when placing the last ring *D* 2, with its prods uppermost, that these prods are kept about $\frac{1}{2}$ in. clear of the loam board. Having satisfied ourselves that the prods are clear of the loam board, this plate, or ring, is bound with the nuts *E*, made for the tubes, as previously mentioned ; and with the vents secured on this uppermost part of the core, the whole core is trimmed, roughed, and finished off with sieved loam according to loam core practice.

Thus the core stands completed according to sizes wanted, and is allowed time to stiffen before the boss *F* can be taken down for finishing. In due time the boss is removed, together with the wood *C* or temporary flange pattern on the bottom, which is in pieces, and when all is finished, core and bottom part of the mould, which has now become *as one combined structure*, is passed into the stove for drying. And here we leave what is considered the best and safest method of

handling a jacket cylinder core, when moulding these castings in loam. Jacket cylinders, whether large or small, should, whenever possible, be made in loam. Dry-sand is not advisable wherever loam is possible.

Gas Engine Cylinder Jacket Cores.—This core in our experience has proved the safest of the kind made in sand, and anything up to 30 horse-power has always been considered good practice in sand; beyond this size it is safer to have a loam core. One good feature of these jacket cores comes from the openness at one or both ends of the barrel, which (1) makes venting comparatively easy; (2) fettling still easier; and (3) gives abundance of “bearing” wherewith to rest those cores—three very essential functions that the gas engine cylinder jacket core provides by the nature of its design, but are almost, if not altogether, denied the steam jacket cylinder core just referred to. Hence the need for the plug cores and other devices in casting steam jacketed cylinders.

There is still here one other very important point of contrast, namely, expansion of core, which takes place immediately after the mould is cast. With the first jacket core considered, it was referred to as being entirely enshrouded in metal. Now, with such a core, it will at once be admitted that its expansion is inevitable, and to this much of the defectiveness common to steam jacketed cylinders, on the top ends, is doubtless due. Not only do we get the swell on the basins visible after pouring, but the expansion also from the core while the metal is in the plastic state, which is without doubt contributory to the mischief done, namely, shrinkholes and want of density common to the top ends of those castings. This evil has more than added its quota of those castings consigned to the scrap heap, which otherwise should have been good castings. If engineers could, or would, have designed for the open end in the steam cylinder jacketed core, as is generally the case with the gas engine cylinder, very much of the heavy losses hitherto experienced in steam cylinder jacketed castings would have been averted. But just because of the losses referred to, the cylinder “liner” was introduced, a change which has given so much satisfaction to all concerned, and for which the founder is doubly thankful.

But let us keep to the gas engine cylinder jacket cores; and what has been said thereon refers to sand moulding of those cylinders whose barrel is divided or parted, the same as a common pipe, therefore these jacket cores are divided longitudinally in halves the same way. These cores are placed in the mould on their bearings and, if need be, supported by chaplets. No plug vent cores being needed, the top half core is simply laid on the top of its neighbour previously placed in the bottom of the mould. The simplicity of this when compared with the cores requiring "plug vents," and the jacket core hung to the top as previously mentioned in sand moulding, requires no further comment to show its advantages, and as a result jacket cylinders for gas engines become a pleasanter job to a moulder, because of the comparatively greater safety experienced in making them.

Core Sands, Core Irons, and Cores.—Sands suitable for these cores are usually made from rock-sand, loam, and milled dry-sand facing sand. Some have a strong inclination for *horse dung* loam, and believe it to be an indispensable constituent of core sand, but in no case do we recognise this dirty practice.¹ Fifteen per cent. of sawdust to whatever quantity of sand mixed will take the place of this obnoxious commodity. It would be gratifying to think that this use of horse dung was a thing of the past, but it is not so, as this manure account in many up-to-date foundries still forms an item of considerable cost. River-sand loam is chosen by some for its porous and plastic qualities. This is not necessary, as the sawdust imparts the first quality and may even overdo it; but for safety in this, a handful of core gum to half a barrowful of sand of the grade mentioned will make the core when baked, quite sufficiently strong for handling and perfectly safe for casting also. If flour be used instead of gum, multiply the quantity by three. This mixture of core sand is very easily fettled, doubtless due to the destruction of the sawdust by the red hot casting.

Core Irons.—These jacket sand cores in halves when made by a good core-maker are quite safe with straight irons placed

¹ Of course, moulders are usually men of many shifts, and if horse manure is easier got than sawdust, use it.

at suitable distances longitudinally in the core-box; other circular cast irons $\frac{3}{16}$ in. by 1 in. or $1\frac{1}{4}$ ins. may be placed transversely at suitable distances from end to end of the core-box. These irons as stated will do all that is required to make a thoroughly good and strong core. Indeed, while coring the job with such core irons for these jacket cylinder cores, no fear of breakage need be apprehended by taking hold of them anywhere with ordinary caution while in the act of placing them in the mould in their respective positions. This again shows the simplicity and convenience of the gas cylinder jacket, when compared with the steam cylinder jacket core.

Jacketed Cylinder Cores for Petrol Engines.—The petrol engine, the latest invention requiring a cylinder jacket core, has put many good moulders into difficult and unenviable positions at times, by losses with these cylinder castings which have been occasionally computed at as high as 75 per cent. The comparatively few years' experience in the internal combustion engine trade has shown many difficulties in core making which, at the initial stage of its existence, seemed insurmountable, through the delicacy of manipulating the jacket cylinder cores. But time has proved all this trouble to be a lack of experience, as we have abundance of evidence to prove that wherever introduced, and after the elementary details were mastered, the trouble of "blow ups" and blow-holes in those cylinder castings in a very great measure disappeared, and ultimately no unusual difficulties were experienced in their production.

The great question with the majority was the compounding of the core sand used; at least such seemed to be the popular belief. Now, however much value may be put on this question of sand, we are afraid it is too frequently over-estimated, and this has been the same throughout all our experience of core making difficulties. Back in the early seventies when the gas engine was in its infancy and probably before the petrol engine had an existence, the casting of small steam cylinders with their tiny steam ports about $\frac{1}{4}$ in. or $\frac{3}{8}$ in. thick was always matter for much concern. In the mixing of core sands for this class of work it was in most cases a "fanciful compound" of one ingredient killing another; these in some

cases counted as many as half a dozen different constituents of one kind and another. In this connection one would almost think in the motor cylinder castings trade that history had repeated itself with more intense ridiculousness in some of these fancy core sand mixtures. In proof of this we give an *up-to-date* recipe thus:—"Two handfuls of gritty dust from near the roof spouting, two-and-a-half shovels of red sand, two shovels of black sand, and half teacupful of core gum." This is copied to prove our contention, but hardly calls for further comment.

Having so far explained the true value of things in this respect to a moulder, and which is borne out by experience, advisedly we say, a great deal more depends on the moulder than the sand. A good moulder or core-maker will find his sand and make it suitable, but the sand will not make the moulder suitable to the sand. With the former many of the fancy mixtures disappear, and with the latter they usually multiply. There is no need for any recipe here further than to say that, what makes a good cylinder "steam port core," will also make good "petrol engine cores," and if there be difference at all, it need only be in the grade, the former being passed through a $\frac{1}{4}$ -in. or $\frac{3}{8}$ -in. mesh, the latter through $\frac{3}{16}$ in. or $\frac{1}{8}$ in. for the jacketed portion of the cores.

Core irons for motor cylinder jackets are usually made from $\frac{1}{8}$ in. thick iron for the longitudinal lengths, and for transverse $\frac{1}{16}$ in. thick will do. In some cases after fitting the core iron it may be necessary to solder it at different parts so as to have a strong and efficient core iron, but in other cases all that is necessary is simply to place the core irons with care, as illustrated by the jacket cores of the gas engine cylinders. Wax vent wire may be said to be indispensable for venting purposes; but above all, make vents good and clear, and do not apply ashes at all. Avoid letting the core become contaminated with wax from the vent wire, and blackwash the cores green.

In the three types of jacket cores dealt with it will be obvious that the progression as represented in this class of work has been stepwise:—(1) the large jackets of the steam cylinders; (2) the medium of the gas engines; and, (3) the small jacket core of the petrol cylinder, that has come into

such prominence in foundry work during the last few years, and according to some has done more than anything else to develop the highest degree of skill and accuracy in foundry practice. The relationship between the jacket cores of the loam made cylinders and similar cores of the gas engine is considerable, and although the principle is much the same in practice, still in certain respects they are quite different. But again, when comparison is made between the smaller sizes of the gas engine and the larger sizes of the petrol engine, a much nearer relationship is found to exist, thus bringing the moulder who has experience in gas engine cylinder casting in close touch with petrol cylinder practice. The materials and methods in the making of those two jacket cores have much in common with each other. Therefore, the gas engine jacket cylinder ought to be a good stepping-stone to the moulding of a somewhat similar class of cylinder castings for the motor castings trade.

CORE-SANDS

In the matter of core-sand some moulders have great faith in strange nostrums, and the various antidotes applied for real or imaginary evils have at times been amusing. And just one case in point. In my early experience, and while working in a certain shop, I saw a small steam cylinder moulded, which was lost three consecutive times, the loss in each case being attributed to the cores. In the making of the fourth set of cores the moulder resorted to the compounding of potatoes with sea sand to the necessary consistency. These cores were handled without blackwashing, stood the test of the metal well while pouring, and resulted in a good casting for all concerned. Needless to say, all the credit for the good result was given to this special mixture, which, by the way, was known to others in the shop long before this incident occurred. Moreover, cylinders from the same pattern had been cast many times successfully with ordinary core-sand. Hence, the fault in this case was entirely due to the man working his sand too damp, and ramming his cores so hard that their easy venting was an impossibility—a clear case of the importance of proper

core-sand consistency and the necessity for intelligent ramming. But potatoes as a binder in the manner mentioned may be used to advantage in the smallest of cores where the placing of a vent is an impossibility, provided that the drying or baking of such be attended to with more than ordinary care. There is no need to enumerate further the various antidotes which have hitherto been in use in British core making. Suffice it to say that these to a very great extent, and in some cases altogether, have been superseded by that handier commodity known as core-gum.

Core-Sands for Large, Medium, and Small Cores.—(1) The term "large" is ambiguous, as in this connection we would do well to consider it as relating to internal form only. Certain parts of moulds, although internal and surrounded on the four sides with metal, as is the case with the legs of horizontal engine bedplates and bottoms, which are usually lifted out to make room for firing (when cast in dry-sand), have much in common with other large cores, but cannot be regarded as such, because these give the outside form of the casting only. Therefore, although a core-sand would be serviceable and safer in facilitating shrinkage, yet it would be altogether out of place here, as a facing sand capable of producing a properly skinned casting would be best.

For large cores ordinary dry-sand facing often suits, but it certainly is all the better if the batch contains about 15 per cent. of sawdust, an article within the reach of most people. Of course, sawdust cannot be used without lessening the cohesiveness of the sand; hence the need at times for the moulder to adopt some sort of a binder to stiffen the otherwise impoverished sand. Sawdust, as referred to, has three very distinct qualities. First, it is regarded as a very important essential to the speedy venting of cores; second, it is not rigid, but yields easily to shrinkage when enshrouded in metal; and third, its very destructible nature, owing to the large amount of vegetable matter which it carries, makes it easy for fettling—a very commendable feature with all cores, but specially with those that are enshrouded in metal. This mixture is as good if manipulated with intelligence, as the best *horse manure* ever applied to the mixing of core-sand,

and gets rid of this obnoxious compound which so many moulders believe to be the ideal core-sand mixture.

Medium Cores.—In this class we propose to regard these as belonging to locomotive cylinders and others of the different types for land and marine engine core work. But even here we feel that each job, large or small, has more or less its own individual requirements. A good base to begin with, in mixing a batch of core-sand for this class of work, is to take two of good milled dry-sand facing sand made from loam offal, to one of rock-sand, but if the rock-sand be not quite so refractory, gritty, and plastic as we would like it to be, then the proportions of rock-sand must be increased, and the milled sand decreased proportionately, plus 15 per cent. sawdust.

In the mixing of this sand, some moulders could not do, as they think, without preparing it with clay water, and in most cases would have to apply a percentage of loam also. Well, here we cannot put down a hard and fast line, as it is to a certain extent a matter of opinion, but nine cases out of every ten, in our experience, could do without either. Clay is an adjunct indispensable to core-sand, but its indiscriminate use is destructive to cores, and a core carrying too much of this material in the sand with which it is made, if not much burned while drying, will undoubtedly prove itself to be troublesome while casting.

The one grand feature of core-sand, along with porosity, is its proper consistency, as regards dampness and cohesiveness, and the best guide we know of in this matter is its behaviour in the core-box. If it is too damp, it will have a tendency to clog, and if it sticks to the box, as previously stated, then we may be sure we are working a dense and dangerous sand. Denseness is usually associated with excessive clay; thus it is that comparative weights of some sands are, bulk for bulk, as six is to seven. The latter had better be kept for cores having at least one side entirely free from metal contact while pouring, and the former used for cores that are enshrouded or immersed in metal, as is the case with pistons and cylinder cores in general.

Next in importance to suitable sand for medium cores is the core ramming, and this is where much mischief is done. A

sand that is too wet will always pack closer with greater ease while ramming cores in general than is possible with sand that is drier. Too hard ramming makes dense and hard cores that are bad from any point of view. Experience alone can determine absolutely what is wanted to make cores of this class, and for the mixing and manipulating of the sands proper for medium cores we fall back on two of milled-sand to one of rock, and 15 per cent. sawdust, as a rule, will suit for all sizes. These, if thoroughly mixed and tramped with the feet (milling is not good here), and allowed to lie some time before riddling for use, will make a first-class medium core-sand capable of resisting chapleting, giving good venting and also expeditious fettling.

Small Cores.—By this is meant cores of the lighter order connected with small work and thin metal. They should at all times be made with a specifically light sand, that is to say, a sand comparatively free from clayey matter, such as sea, loch, or river sand in their finest condition. Core-sand made from any of those sands with the requisite material for binding makes cores that are easily vented and easily fettled. It is, however, in this class of cores that the greatest amount of quackery is practised. Beer, porter, molasses, salt water, etc., were common many years ago in mixing sand for light section cores. Sands that are heavy and plastic are non-porous, and are entirely unsuitable for light work, as they contain too much gas-producing substances which render them at all times dangerous in the production of light and good castings. But if circumstances compel one to use a heavier sand than would otherwise be the case, much good will result from burning the cores while drying, but only to such an extent as partly to destroy the vegetable matter that is in the sand of which the cores are made. Indeed, all cores that are made with a heavy sand, such as the ones referred to in medium cores, are all the better for being tinged by the fire in the process of drying. This will improve them in every respect, but especially in venting and fettling, and of course black-washing must follow this method of drying.

The following is a recipe for small cores: 20 measures of sea sand, and 8 measures of black sand, to which 1 of core gum

is added. This will make a suitable sand for general light work. Of course this mixture can be varied according to circumstances, and cores made from it should be kept out of the mould, especially if it be a green-sand one, as long as possible preparatory to casting, as dampness soon develops and makes them bad for casting. Flour is better than core gum for this mixture, but is too costly for British foundry practice.

Then again, a very suitable core-sand for the lightest and most intricate of small cores is made by compounding potatoes with sea sand to a consistency of ordinary core-sand. If the sand be entirely dry, add potatoes until the desired consistency, by kneading, is brought about, thus completing the mixture for use. No vents, as a rule, with this potato mixture are necessary in the smallest of cylinder cores.

MOULDING A CORLISS CYLINDER IN DRY-SAND.

So much has already been said on cylinders moulded in loam and sand that it would not be wise to spend time on the preliminaries of moulding Corliss cylinders, since the methods described for slide valve cylinder moulding will adapt themselves to Corliss work as well. It will be sufficient, therefore, to treat only of the fundamentals of coring, closing, and the necessary essentials for working out these jobs on the lines of good foundry practice. To describe in detail and fully illustrate the moulding of this job would, it will readily be admitted, alone fill a fair sized book, but it is hoped that enough will be given to guide even the novice in how to proceed with the moulding of Corliss cylinder castings.

And let it be said that whatever difference there may be in making a "Corliss cylinder in loam" when compared with moulding the same type in dry-sand, this difference is accentuated more forcibly in the cores; and the dry-sand mould of this class of work is usually moulded and cast horizontally, while that in loam practice is cast vertically. Now, without seeking to discuss whether there be more ways than one for moulding these in loam, or even dry-sand, and the various methods of manipulating the valve cores, as will be illustrated

further on, let us for the present show in as precise a manner as possible the different workshop practice of dealing with the cores when moulding in the position referred to. These methods we summarise as follows:—(1) “The three-core method,” (2) “the five-core method,” and (3) “the seven-core method.” These three divisions in a somewhat summarised form will show precisely the various methods of moulding

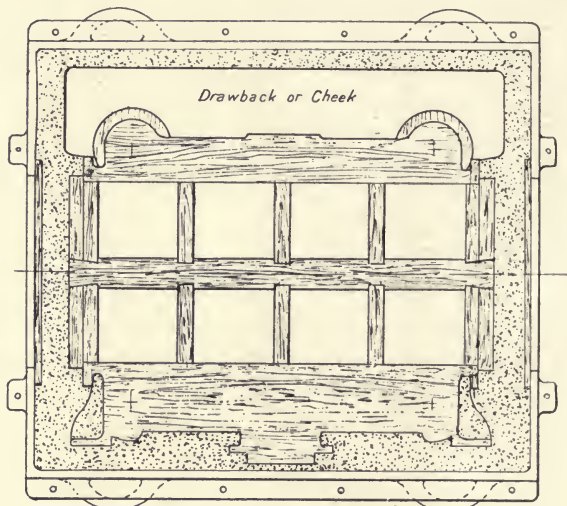

FIG. 73.

Corliss cylinders in dry-sand. It must be distinctly understood that the figures used to illustrate Corliss cylinder moulding here, although drawn to a scale, are only to be interpreted as they apply to this subject; but the principles involved and enunciated here in moulding these castings, will apply themselves with general usefulness wheresoever Corliss cylinder founding is practised.

The “three-core method” of moulding a Corliss cylinder (Figs. 73 and 74) shows the joint to be that of a common cylinder cut through the middle of the barrel and moulded on the principle of an ordinary pipe, as most moulders would say. But this is only true within certain conditions of coring the job, and it is these conditions which determine the *modus*

operandi of moulding—that is to say, whether it shall be as plain as a pipe, or whether there shall be employed the “cheek,” or drawback, as seen at Figs. 73 and 74. The most common, but perhaps not the best, way of moulding these cylinders in dry-sand is to do without the “drawback,” as seen at Fig. 73. But in order to expedite matters and give a superior job, the “drawback” referred to is imperative, because of the great convenience it affords while coring the job, as will be referred to further on. The “drawback’s” specific purpose is to give ample room for placing the cores in the mould, as will be seen by a look at the figure referred to.

In studying the details of this job, the best thing one can do is to seek to comprehend in full Fig. 74, which is a sectional end elevation of the mould, closed with its cores and in general completeness. A view of this figure as it stands

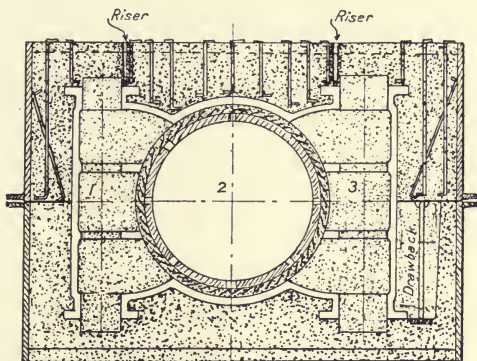

FIG. 74.

at once suggests the difficulties of getting these cores into their positions because of the extraordinary circumference of their “clip” and bearings, or port mouths, of the valve cores that are seen to be lying close against the barrel cores (Fig. 74).

In the sectional elevation of Fig. 74 three cores are represented as counting 1, 2, 3, from left to right, and let it be clearly understood that this method of moulding is only possible with the aid of the “drawback.” Now, as has been said, the greatest difficulty with this job is that of getting the cores placed safely in their respective positions in the mould; therefore study well Fig. 74.

Assuming the cores to be all ready, the job is cored in the order represented in Fig. 74, and it is also necessary to explain that, before “coring” for good, the moulding boxes top and bottom (Fig. 74) should be tried on and proved correct

in every detail that goes to make a true joint on the casting, as also the measurement of bearings, so that a true divide of metal, as it affects uniformity of thickness in the barrel, or otherwise, may be secured. This being done satisfactorily, and the top part taken off and laid aside, along with the "drawback," which is taken out for the convenience of "coring," we begin to core in the order as illustrated at the figure in question.

In commencing to place these cores in the mould we begin with No. 1 core (Fig. 74) and its end neighbour, not shown in figure, and when both valve cores are lowered and placed exactly vertical in the required position we next sling the loam core, No. 2, for the barrel. In placing the barrel core, a little extra caution will be required so as to keep it from coming in contact with the points of the valve cores referred to at Fig. 74, and the mould thereafter being thoroughly cleaned out, the "coring" is completed by placing No. 3 core and its neighbour in the same way as No. 1 core. Thereafter place the "cheek" in position.

The Five-Core Method.—Being agreed that the cores are the dominant factors in moulding Corliss cylinders, Figs. 75 and 76 represent two other ways of manipulating these cores while placing them in the mould. In Fig. 75, *A A* is a joint which indicates that the cores numbered 1 and 3, as illustrated in Fig. 74, are cut longitudinally for the convenience of placing these two cores, steam and exhaust, in the mould as shown. In examining Fig. 75, the numbers 1, 2, 4, 5, and the joint line *A A* denote that the steam and exhaust cores, which formerly were shown in Fig. 74 as complete, are cut in the "five-core method" through the centre, as already referred to, and thus become four separate cores or half cores.

The order of coring in this method is denoted by the figures in the illustration (Fig. 75), and if this be attended to no mistake or hitch of any kind can happen during the process of coring the job. The necessity for making five cores *instead of three* as in the first method needs but little explanation, as the figures in themselves will, perhaps, be conclusive. However, this method looks quite a simple and convenient way of handling those cores, and for a moulder's convenience of placing them looks to be all that could be desired. Of course

with the five-core method there are five cores to set instead of three (when viewed from end elevation, Fig. 74), which means more time in coring. But, on the other hand, it can be said no "drawback" is required in this method of moulding the job. This being so, the cores do not count for so very much after all, were it not that there are other things to be considered; but, from an engineer's point of view, this method is not commendable. Further, it is a vital question in all foundry practice to avoid, as far as it is possible, encroaching on, or disturbing, the continuity of lines in valve faces. This carried out as a principle together with the nastiness of the joints, whether in forming a fin or otherwise, as shown in Fig. 75, *AA*, makes the five-core or longitudinal splitting method of moulding and coring Corliss cylinders in general foundry practice very unsatisfactory. So much for this; we pass on to what I have chosen to call the seven-core method.

The Seven-Core Method.

—In this, the third and last method, let it be remembered that all materials and details are the same as in the previous one. The position of the arrows in Fig. 76 at once show where these cores (that is to say, steam and exhaust, on both sides of the barrel) are subdivided into three separate cores, and by this process cores Nos. 1 and 3, of Fig. 74, count for six cores as against two in the three-core method. These six cores added to the barrel, of course constitutes what has already been designated the seven-core method of moulding Corliss cylinders.

Hence it may at first sight hardly seem correct to say that in these three methods of moulding Corliss cylinders, we have three, then five, and lastly seven cores—three separate cores (Fig. 76), for both sides of the mould and the barrel core make seven—and yet the result in the end comes out practically the same with them all, at least in so far as we view the work

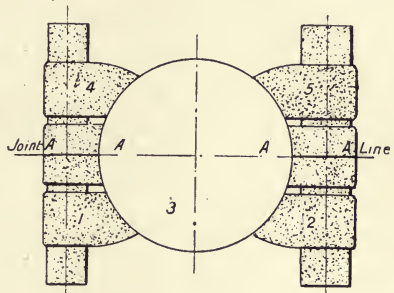

FIG. 75.

done, and as illustrated by Fig. 74. Nevertheless, the foregoing is too true, and demonstrates what is common in foundry practice, and which not infrequently throws those in charge into a dilemma to know what plan is best at times to adopt. But in this case, where all things are supposed by some to be equal, the three-core method with its "drawback," as illustrated by Fig. 74, is by far the best, no matter from what point of view it be tested.

Again, "the seven-core method," although many adopt it, is really bad for everything. Each of these cores must be handled separately (*i.e.*, in the larger sizes), and are in every way independent cores, which is in principle opposed to the economy which grouping of cores, wherever practicable, produces. Grouping expedites the work of "coring," and so saves

time and money in this or any other division of moulding.

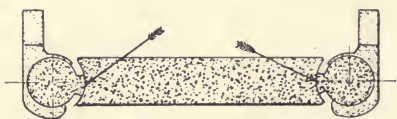

FIG. 76.

This method also creates confusion, inasmuch as each core has to be conducted by one or more men while placing the four valves and main cores in their positions. Such an arrangement as this causes much confusion, as all are naturally trying their best to get placed at one and the same time in their respective bearings, and each man feels quite relieved when landed there without mishap of any kind. Wherever confusion exists in the placing of cores, mistakes or breakages of some kind are usually inevitable, and as a result time and money is wasted, with inferior workmanship as well.

At this juncture there are now five cores placed in the mould, namely, the four valves and the barrel, which leave the steam and exhaust chamber cores to be placed in turn. These cores, illustrated in Fig. 76, are parted or separated at the points of their respective "arrows," and wrought with a moderate "fin," which is allowed to go, and is burst and cleaned by the fettler at the time of dressing the casting. If the "fin" is placed as shown at the "arrows," all will be well; if on the other side next the valves, much danger will follow, as the bursting of the "fin" may spoil the line of finish in the

valve casing, in consequence of which much risk of losing the casting ensues.

The advantages and disadvantages of the three methods of moulding and casting horizontally Corliss cylinders that are made in dry sand may now be summarised. (1) Three cores constitute the interior of the casting, which is without any "fins," except the mouth of the ports in the barrel, which are of no consequence whatever. Also fettling is expedited and good workmanship secured by this method in less time than when done in any other way. (2) Five cores, or the splitting of the sand cores longitudinally as suggested, and as seen in Fig. 75, are very agreeably and easily handled, but the dangers of disturbing the vertical lines of the valves and contour of the mouth of the ports at the barrel are great. These, together with the fins referred to, make it unsafe for good workmanship when passing through the iron-finishing departments. (3) Seven cores may be said to be bad for everything (unless vertical moulding, and in all probability loam), first, because time is wasted and abnormal risk is involved in making and handling them in every way, as well as in securing them in the mould. In this method also extra work is involved in venting seven cores instead of three or five, and there is the objectionable fin, as previously mentioned, in the position shown by the arrows in Fig. 76.

Now that all cores are supposed to be in position (dry-sand horizontal moulding) and as near to what they should be as possible, much care in checking them by measurement, to see that all have their true centres in line with the bottom centres of the valves, is imperative. Sometimes the valve cores have been set by rule of thumb, and to the eye looked all right, even on entering the top prints,¹ and were cast accordingly; but when they reached the "drawing-off" process for finishing in the machine shop they often proved themselves all wrong. Therefore nothing short of a systematic measurement, as here suggested, can guarantee these valves as nearly as possible centre to centre. But it must be borne in mind that the difficulties of finding the centres in the foundry are

¹ Or core bearings.

somewhat greater than in the other departments ; still, this need not be an excuse for defectiveness in the parts referred to. What the moulder has to do in proving these cores is very simple, and, indeed, speedier than any rule of thumb can be. He has only to get two oblong pieces of 1-in. wood, whose combined measurements should be 5 ins. or 6 ins. greater than the diameter of the core, the centre lines of the barrel to be drawn on these, and the diameter cut an easy fit for riding the barrel core. This will enable these two saddles, squared and levelled with the faces of the barrel flanges, to control all measurements endwise. This done, the inside measurements should be taken from the centre line of a straight edge, resting true to the centre lines of the saddles, and assuming the pattern to be correct, and cores made correctly from good and true core-boxes, no one with ordinary care need have the slightest fear in turning out Corliss cylinders with the cores in their proper places.

The foregoing method is not costly, and in many cases has paid for itself many times over, not to speak of the superior job ensured and the pleasure it affords to all interested, and which of course redounds with double credit to the foundry. Further, if the future of the foundry is to be improved technically, I can think of nothing the moulder has more need of than a thorough knowledge of the constructional parts of the steam engine, and such parts of engineering where much time and money is lost through cores badly set by the moulder.

The importance of chemistry and metallurgy to an intelligent and practical foundryman goes without saying, but if these be advanced to the neglect of what has been hinted at here, the ability to produce the greatest amount of good and efficient workmanship at the least possible cost will in a considerable measure be lost.

GENERAL PIPE CORE MAKING

The extent to which this branch of foundry practice could be taken is practically without limit, as can be seen by a

glance at the many divisions of moulding and the peculiarities of each division of core making. To give absolute justice, each core treated ought to be taken in detail as to methods of making, composition of materials, and with not less than one sectional illustration showing its "iron," vent, and general texture; and so showing vents that are open or made of ashes, and demonstrating in a general way the strength of the core for the purpose intended; also its porosity, and the speediest method possible for the exit of the gases of the cores under consideration should be dealt with. It will be readily conceded that to treat this subject in such detail is beyond the possibilities of a text-book such as this.

For example, take pipe foundry practice, which is altogether different from what has been previously dealt with, and what do we find? In this class of work we have a system of core making absolutely unique inasmuch as cores are made here with materials and under conditions of foundry practice that are unadaptable to any other branch of moulding, and at a speed of production, with its consequent reduction of cost, which is nothing short of marvellous to the uninitiated on entering a pipe factory for the first time, no matter whether he be layman or practical moulder.

Green-Sand Cores.—In the jobbing green-sand department we find bends, tee pieces, branch pipes, and all sorts of "specials" for the pipe trade, being cast with green-sand cores. Cores made thus are produced from the patterns that make the moulds, so that no core-boxes, in the usual sense of the word, are used in this department of pipe founding. These patterns, technically known as "shell patterns," in appearance look like the castings to be made cut into halves for the convenience of core making and moulding.

The sand for this class of core is practically that which is used for the mould, but instead of blackwashing, as is the case for skinning a dry-sand core, the cores are well rubbed up with dry blacking, as is common to green-sand practice. Venting is done in the ordinary way, but with some of the larger diameters the open vent is aided with suitable ashes, and judiciously pricked with the vent wire immediately below

the "drop" and flow of the metal from the pouring gates, thereby securing greater safety from scabbing at this most dangerous part of the casting.

Core Irons.—For this method of core making these must be rigid and strong; but, whatever is permissible in the way of chapleting, etc., in dry sand or loam, the same is absolutely inadmissible in green-sand core practice, and, as a matter of fact, provision must be made on the core irons, both for carrying up, if need be, and keeping down the cores while under pressure at the time of pouring the moulds. Fig. 77 is a small bend showing in plan the core-iron passing round the end of the moulding-box, and marked thus, X, where it is carried up, and held down when wedged "iron-and-iron" with the moulding-box. A plain core-iron for the smallest of bends and made as illustrated in Fig. 77 is quite sufficient, but larger diameters must have "winged core-irons," the wings being divided at about 6-in. centres, and about 1 in.

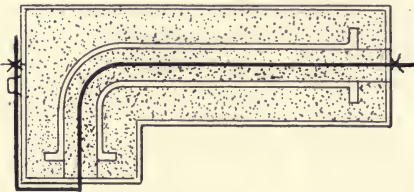

FIG. 77.

a-side clear of the internal diameter of the pattern, which of course is the core-box for a shell pattern. The centre rib and wings of the core-irons in question must be in proportion to the diameter or

weight of core any given core-iron must carry. Thus Fig. 77 but barely shows the principles of a core-iron, etc., which might be any weight known to "bend pipe casting" without chaplets or *stangeys*.

Pipes cast with core irons of this description and where no chaplets, etc., are used, are always superior castings for duty, as against those cast on jobbing lines with the orthodox use of chaplets, nails, or *stangeys*, these being responsible for a goodly percentage of the losses in jobbing pipe founding.

Cores for Bank Pipes.—This is one of the most interesting branches of core making in moulding. Bank pipes above 2 ins. diameter and upwards to 10 ins., are cast in 9-ft. lengths,

below this in 6-ft. lengths; therefore, allowing not less than 6 ins. at each end of the pipe mould for "bearing," these core-boxes should be approximately 7 ft. and 10 ft. long respectively. All these cores are made on benches and with a strong iron core-box as shown in section at Fig. 78, which opens and shuts on hinges, a thing common to all bank pipe core-boxes. The speed with which these cores pass through the hands of the core makers, who, as a rule, are the pipe moulders, is characteristic of the movements of these moulders from the start of their day's work to its finish. For instance, a 10-in. pipe core has been found to take eight minutes to make completely, plus the time occupied preparatory to starting a set of ten for a day's bank casting of this diameter.

Fig. 78 is not drawn to any particular scale, but merely to give a sectional idea of what these cores contain and the method of making them, which is as follows:—First, a little sand is put into the bottom half of the core-box; after this the core-iron *A* (Fig. 78) is bedded solid, as shown in this figure; the vent *B* is formed by a rod of iron rammed up in the core in the bottom half of the box; next, the top half is rammed, and due care is taken here to see that the stud *C* is solidly bedded on to the face of the top side of the core, as shown in Fig. 78. At this point we conclude the core to be jointed and parted and taken from the core-box, afterwards finished and blackwashed green. The finish of these cores preparatory to their being placed in the moulds, is the placing of them in the stoves for drying purposes, hence they are called "dry-sand cores."

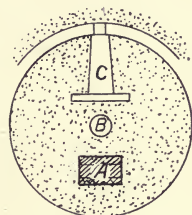

FIG. 78.

Vertical Loam Pipe Cores.—Passing on to the vertical section of pipe cores in a pipe factory, we get two distinct methods of core making, viz., loam and dry sand. The first is by straw ropes with first and second coating of loams of two distinct qualities.

There is nothing unusual about these cores; it is simply a case of coating and drying alternately, so that no illustrations

in this branch of core-making are necessary. Suffice it to say that these cores are run up horizontally and are dried in this position, and after being blackwashed and again dried, are slung into the vertical position and placed in the moulds preparatory to pouring. This composition of core, viz., straw (or wood wool) and loam, is used for vertical pipe castings, say, from 3 ins. to 20 ins. diameter, and from 9 ft. to 12 ft. in length.

Loam cores are the costliest of all cores, nevertheless they are the safest when used under normal conditions of treatment, and in many cases become the cores of all cores when others fail, as they have no equal for safety of venting and strength of surface, which give density of skin on the casting, fragility for easy contraction which at all times avoids slackening, so as to prevent irretrievable loss from bursting of a casting while shrinking and cooling to atmospheric temperature; and last, but not least, a core as here suggested has no equal for speedy fettling.

Core bars used for this class of cores are of two different kinds, grooved and hollow, the former being solid with grooves running from end to end for the passage of air and its speedy discharge from the top end while pouring the casting.

The larger diameters are made hollow and perforated with $\frac{5}{8}$ -in. or $\frac{3}{4}$ -in. holes at about 8-in. centres, these being more than sufficient for the purpose intended. The above gives but a brief outline of pipe factory loam core making for vertical dry-sand pipe founding from 3 ins. to 20 ins. diameter, and from this we pass on to the last method of pipe core making in pipe factory practice. Perhaps it should be mentioned that from time to time attempts have been made to make loam cores in the pipe factories without the use of straw ropes altogether, by using a porous and fibrous loam capable of adhering to the core-bar and working to a finished core. So far this has had but small success; indeed, the epithet "not impossible, but impracticable," in my opinion, is, to say the least of it, most adaptable.

Vertical Dry-Sand Pipe Core Making.—Some foundries use a "kellet," the face of which is made of loam, while others have

nothing from the base of the faucet down to what may be called the parting line. Nothing but iron, or in other words the iron drag is tightly bolted to the carriage on which it is placed. This in turn has the core-bar fixed in position, and standing perfectly erect, ready for the core-box which enshrouds it preparatory to the operation of ramming the core. So that with carriage and wheels, we have a vertical height of 16 ft. or 17 ft. from the greatest lengths of casings, and in order to get at the ramming of these cores, scaffolding about 3 ft. below the level of the top end of the core-box is provided for the men who are thus engaged ramming. It is interesting at first sight to see these men, sometimes three or four, or even more, marching round on the scaffold, manipulating their rammers with that precision which marks in every stroke good workmanship; while another man keeps up the supply of sand. The rammers are of various lengths, the longest being a few inches more than the length of the core which is being rammed, and are changed for shorter ones at the different stages while progressing upwards, until the ramming is finished.

At various times machine-ramming has been introduced in this class of pipe founding, but, so far as the author knows, its success has not been established. Hence it is that hand-ramming holds the field against all mechanical methods in so far as good workmanship and cost of production in the ramming of vertical pipes in pipe foundry practice is concerned.

On the core being finished at the top, the core-box, which, of course, is of iron and finished with a workable taper, is next taken away by being drawn right up vertically, and passed over the top of the core entirely out of the way. On this being done the faucet core-box, which is in halves, is next placed in position, then rammed, and by this last movement of ramming the core is completed, save for finishing and blackwashing.

The carriage containing the core when finished is passed into the stove to dry, and as the amount of sand on each side of the core bar of these cores need not be more than 2 ins., it will readily be noticed that they are not difficult to dry.

This is more especially the case with the larger diameters in this division of core making in pipe factory practice. Of course these core-bars are perforated with vent holes in the usual way, and the sand with which the cores are made is of the ordinary mixture of "black" and rock sand, the latter being proportioned according to the strength of the black sand; but frequently two of *rock* to one of *black* is quite safe for all purposes.

Obviously such a core as here described would give trouble were it placed in a mould cast in any other position than the vertical one. As a result, we see that metal, while flowing in a mould will practically lie to any form of sand, whether it be cope or core, if dried and in the vertical position while casting. By this we see clearly that while such a core as described is everything that could be desired so long as it is used in the position referred to, a core made on this principle, at least with medium and larger diameters, would be utterly unsuitable for pipes that are cast horizontally.

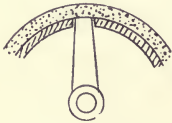

FIG. 79.

Hence the importance of watching the positions of cores in a mould, and dealing with them according to their individual requirements. Therefore it is that all cores of this type must be slackened to facilitate shrinkage, and thus lessen danger of bursting the casting. For this purpose many are the devices of "collapsible bars" that have been tried, and are in use, for the expediting of slackening vertical-cast pipe cores.

Fig. 79 is part of a V slit which passes from end to end of the core-bar and is held in position by a simple form of mechanism. This slit, at the right moment after the pipe is cast, is undone, and thereby the bar, in a measure, collapses sufficiently far for the safety of the pipe in shrinking. This done the bar is ultimately removed by rapping, and the pipe becomes absolutely safe for shrinking. The operation of slackening can be facilitated by these core-bars having a little taper towards their bottom ends.

All are not agreed as to method of slackening the core-bars to facilitate shrinkage. All the same, they use the

space as shown in Fig. 79, and fake it with steel plate, of course with due regard to efficiency of core-bar and flexibility for shrinkage.

CHILLED CASTINGS

When fluid iron of suitable composition is cast in contact with cold iron the casting has a skin or surface layer of hard white iron and is known as a chilled casting. A chilled casting may be made by casting with a metal core or in a metal mould, these being known respectively as "mandrel" and "chill."

Mandrels require a coating of some substance such as blackwash, oil and parting sand, or, what is far better, common tar, in order to promote their easy discharge from the casting. Tar, if judiciously applied, will produce the hardest and most glassy skin possible on a chilled casting. Mandrels should also always have sufficient taper to admit of their easy discharge from the casting.

Chills are made of cast iron from patterns in the usual way, and are used for the purpose of hardening outside surfaces of castings, such as illus-



FIG. 80.

trated at Fig. 80. Opinion is divided as to what should be the thickness of the chill as compared with the casting to be chilled. Some are strongly in favour of making chills 1 in. thick to every eighth part of an inch, for whatever thickness of metal the chill has to contend with during the process of chilling. Now, according to this, $\frac{5}{8}$ -in. metal in section would mean 5 ins. thickness for chill, and from the same standpoint $\frac{7}{8}$ in. would mean 7 ins. Such would work out ridiculously, as an anvil face of about 10 cwts., roughly put,

would require a chill casting as thick in section as the anvil face casting referred to.

It is common to some classes of chills to crack at a first use, and become useless; therefore all chills should be cast of the strongest iron possible, and hematite iron is often used. The cracking of chills is mostly confined to those of cylindrical design, and to minimise such accidents, the use of binders and malleable hoops is extremely commendable in the case of heavy cylindrical chill moulds or chill casings. Chills of every section should be cast with hematite iron or brands not inferior in quality and low in graphite, silicon and phosphorus. From these brands, on account of their superior density and purity, the best possible chills are obtained. Were it possible to make chills of perfectly dense metal free from graphite, silicon and phosphorus, the maximum chilling effect would be produced, while at the same time such chills would have a much longer life.

A chill having a burned face has the effect of giving imperfect chilling as well as an imperfect face on the casting. As soon as a chill reaches this stage owing to repeated casting it loses its power of chilling properly, and this with irregularities of surface condemns it as a chill. Wherever chills are employed care should be taken to keep them free from damp; and on this score much care is advisable, otherwise, there may be an accident when fluid metal and chill come in contact with each other. Therefore, see to it that iron chills are dry through and through, and entirely free from oxide or rust of any kind.

Flat surface chills that are defective, will not permit of patching of any kind, no matter however small it may be. Rubbing up with plumbago and oil is a common practice, but these must be discriminately applied, and care taken to see that none of this compound sticks to the chill; but, with a polish produced therefrom, and if the above precautions be observed, a satisfactory casting should be produced with safety when cast at a heat compatible with proper running.

Chilled Cast-Iron Wheels.—It has been said that chilled wheels are distinctly an American product. Be that as it may,

the writer is old enough to remember that chilled cast-iron wheels for general waggon and coal-truck building were quite common for many of the side and some of the main railroads, traffic in Britain. But these have long since been prohibited on all railroads in this country by legal enactment. Those wheels when cast in this country, besides being chilled on their rims, were also cut in their bosses, and were afterwards bound by malleable hoops, and by this means their safety was doubly assured against springing from undue strains, an evil from contraction to a greater or less degree common to all wheels cast with solid centres. Wheels that are cut through their solid centres, as a rule open up with a loud report as the tool is nearing the end of the operation of cutting, the smallest diameters sometimes giving the loudest reports, but which, in any case, is a tell-tale of undue strain on such castings. There is nothing patent to describe in the moulding of these wheels; each wheel has its own chill, and it is bedded in the usual way, moulded and cast with a suitable mixture peculiar to the wants of the car wheel trade.

Design.—Much stress is placed upon the designing of car and bogey wheels, and the influence of the chill as well has got to be reckoned with, while the arms and boss must remain grey, thus making the boss suitable for boring. The rim or tread of the wheel, when right, should be chilled to a depth of not less than $\frac{3}{4}$ in., grading itself from the grey colour within to absolute white on the surface. A gradually chilled texture from the surface inwards is always better than a sharply marked line of demarcation. The usual thickness of these wheels is between 3 ins. and 4 ins. and their depth is governed by the width of the rim and the flange of the casting. The ordinary depth is 4 ins., and on calculation the section comes out at 4 ins. by $3\frac{1}{2}$ ins. These calculations and the section of the chills used in their production are taken by some as important factors in the manufacture of chilled wheel castings.

Metals most Suitable.—Iron for chilled castings, whatever be the mixture, must not contain more silicon sulphur or phosphorus than is compatible with the safety of the casting while

shrinking. For ordinary chilled castings the analysis should read thus:—

Graphite	2·75 per cent. to 3·00 per cent.
Combined Carbon	·60 ,, ·75 ,,
Silicon	·50 ,, ·70 ,,
Manganese	·30 ,, ·50 ,,
Sulphur	·05 ,, ·07 ,,
Phosphorus	·35 ,, ·45 ,,

Annealing Chilled Wheels.—This process is simple. After the wheels are cast they are lifted when they are still at a cherry red heat and placed in suitable pits, in which they are allowed to remain for five or six days, by which time they are perfectly cooled down, and by this very slow cooling casting strains become considerably equalized all over. Pits for this process of annealing are made to contain any reasonable number between twelve and twenty; the pits being closed in order that the process of annealing may go on most satisfactorily. Other types of castings might be dealt with, but space forbids. Suffice it to say, that all chilled castings or partially chilled castings are made from metal moulds, or from moulds that are partly of metal according to the needs of the casting to be operated upon. For other methods of chilling, or modified chilling, see Fig. 86. However, we must never lose sight of the fact that chilling by iron moulds is always most satisfactory when applied to plain surfaces where shrinkage, under normal conditions, develops uninterruptedly.

Sandless Castings.—For a number of years back there has been cast what is known as sandless pig metal. This is cast in iron moulds or chills. The term “chill” is a misnomer in sandless pig metal, as practically no chilling, in the sense of the term, is effected, nor is intended, the whole arrangement being simply a mechanical process for speed in pouring, or casting, at the modern smelting furnace, where moulding according to usual pig-bed casting practice would utterly fail to supply sand moulds for, say, from two to three hundred tons smelted in every twenty-four hours, some furnaces being credited with an excess of the maximum mentioned. Thus far the contrast between chilled castings and sandless castings is comparatively clear.

But to take a more recent date, we have it on authority that many castings which hitherto were cast in sand-moulds, can now be got phenomenally quicker from "iron-moulds" or chills, because what took hours before to cast, can now be done, *it is said, in as many minutes*. This applies chiefly to the motor car castings trade, and has special bearing on cylinders. The secret of this process is said to be the result of many years' research and experimenting. The foregoing we pass by without serious comment, but assuming the process to be as reported, we are safe in saying that it is but in embryo, and the chances are that it will take us many more years, if ever it is seen, before this process of moulding will establish itself on the lines suggested, which are those of economy in the costs of production.

However, if the term "sandless castings" be new, the process of casting in iron-moulds has been in operation since our earliest recollections of the craft. Sash weights, bedsteads, etc., and core-irons for the foundry being cast in light sections thus  are made from iron-moulds that are cut from malleable iron or steel blocks. Such core-irons are very serviceable, and more economical than when cast in sand, according to use and wont in core-iron moulding, and where specialty work is done.

Iron-moulds that are used for the production of marketable castings must have a coating of some refractory material that will also put a passable "skin" on the casting. For this purpose a French-chalk, or plumbago-liquid, or perhaps a compound of both, with sufficient adhesion to the iron-moulds, is applied by painting or spraying, according to usual foundry practice, and if of the right mixture, this application should not need repeating oftener than with every three or four consecutive castings. This fluid should be sparingly used; as no iron-mould or similar vessel can be "skinned" or coated either with vegetable or mineral substances, without causing the generation of gas when in contact with fire, or fluid metal. From this view-point it is seen that gas has got to be reckoned with. Therefore, the thicker the moulds are coated with the substances in question, the trouble with gas, or air, at time of pouring the moulds will become proportionately intensified; and there being practically no escape for gases

from iron-moulds, except between such joints as they may possess, the chances, apart from all other considerations, are all in favour of a sand-mould for successful casting. With a foundry of iron-moulds, we only require a place to melt metal and a covering from the weather, conditions for moulding that are too rosy to be real. From the foregoing we see that "sandless-casting" can scarcely be said to be moulding; consequently, this branch of the trade is reduced to "casting" only, and in that way establishes the distinction, in a measure, between moulding and casting. At the same time we may take it that, with sandless or iron-mould casting, nothing but the sash weight or castings of similar design is possible, and a contrary opinion shows a want, or at least a limited knowledge of the laws of expansion and contraction. Hence, with snugs, claws, and the hundred-and-one projections common to almost every type of casting, the wonder is how there should be two opinions on this question of foundry practice.

Of course, much in this direction is hoped for from soft irons, with a minimum of shrinkage; and if for argument's sake this be admitted, how is iron with an excess of silicon going to suit motor-car cylinders, the casting of special consideration attracting the attention of those who advocate this so-called new process of sandless casting? Silicious iron will no more do for cylinder castings, in my opinion, than cold blast iron, compounded with white metal, will suit pipes or hollow metal castings, and such like.

FLASKS OR MOULDING BOXES

The importance of having a suitable box for any given job is naturally the first concern of every moulder since it increases or diminishes so materially the cost of production, both in the matter of time and in securing a good casting. At no time can we say that "British practice" was anything but iron flasks. Still, to know that wood may be substituted in some cases for iron, as in "American foundry practice," may not be without its advantages; although it may be mentioned that wooden flasks in America are now being displaced by the superior iron flask, doubtless due to the wonderful

development of the iron industries in the States during the last fifteen years.

With this part of foundry plant the assets of any foundry concern may be unduly increased by boxes being indiscriminately made, perhaps, for one or two castings only—not an unusual occurrence with some jobbing foundries. Hence it becomes a matter of first importance in pricing for castings to see what sort of plant there is for such and such a pattern before fixing a price, otherwise mistakes will undoubtedly occur.

The impossibility of illustrating the innumerable types of boxes for a jobbing foundry goes without saying, and the man who has only one way of making any given job, or by one plant only, is by no means fully qualified to manage a jobbing foundry. But the man who can determine to make plant, and thereby show a saving in the aggregate cost of his castings, as against another man who may be wasting money by working at the same job with unsuitable plant, is the only man, in my opinion, who is entitled to hold the management of a foundry that means business. Consequently, two or three examples, together with what is already given on this subject in this work, may suffice to illustrate the general and most economical principles in foundry moulding plant.

First, in the making of a horizontal or Corliss cylinder box, say, 2 or 3 tons' weight, one might insist on having each half cast in one complete piece, which of course would mean its four sides (or sides and ends) and bars arranged on pattern or otherwise, and other attachments as the case may be, all in one complete pattern, while another man would, perhaps, build it with bolts, bars, sides, and ends that were cast separate. Therefore in such a case a frame, or plate pattern for the sides and ends, and a single pattern to cast bars for same, cover all expenses in the way of making a cylinder box pattern for large cylinder moulding on the lines of practice referred to. Moreover, the principle of providing for future alterations, or extensions, is at all times worthy of consideration, and this is specially the case either with jobbing or special plant, the latter being at times very costly—such as, for example, the casings of ordinary vertical pipe factory plant, where

the lengths of the larger diameters vary from 9 ft. to 12 ft., or even what is now more up-to-date, 13 ft. 1½ ins. long. Subjoined are a few "fakes" in box-pattern making, which gives an outline of the needs in this division of a jobbing foundry, etc.

Fig. 81 is an oblong sketch of a top part flask, which can be made as shown with its two corners cut, so as to reduce weight, and thus make it more suitable for half-wheel castings, etc.; but whether it be cast as illustrated or truly oblong, the working out of this proposition is the same. In moulding this box it is not necessary to have more than one half of the pattern, and not as illustrated, the rest being made from sketch or dimensions; but it must be made by a moulder

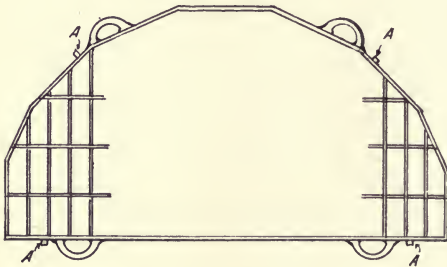

FIG. 81.

who knows his business well, or else the risk of getting a scrap instead of a box casting as desired will be doubly intensified by this procedure. It will be observed that in the design the handles are cast iron.

These are safest and best when put in position after all the preliminaries of moulding are past, as by doing so no danger from damp is at all likely to be experienced. These handles are made from a block core-box, as described in "Starting a Small Foundry" (p. 8 and Fig. 8). To those who may have a dread of cast-iron handles as thus described, it may be pointed out that even although you may have 20 tons to account for there is no danger because, if properly designed and proportioned for their work, they will stand in places, in some cases, where the malleable handles would be a failure; at least, such is the experience of the writer, and under normal conditions of working I never saw a failure.

The four studs or snugs at their respective corners, and marked A, are for staking purposes. The pattern pieces consist of the following, and are partially illustrated in Fig. 81.

The outside parts and internal parallel pattern pieces are approximately 9 ins. to 10 ins. deep, cut to suitable lengths, by $1\frac{1}{4}$ ins. thick, and finished in the pattern shop to a workable taper; all cross bars to be set at 6-in. centres, $\frac{1}{2}$ in. less in depth than the bars above mentioned, greatest thickness 1 in., and to be chamfered according to pattern-box practice in foundry plant.

Fig. 82 represents a box part pattern for a V-grooved wire-rope pulley moulding-box. This box, when completed and cast, should measure 18 ft., which would give about 4 ins. a-side for parting surface at its narrowest part. Fig. 82 is but a twelfth part of the circle, and a pulley box of this description is made by twelve consecutive shifts of the pattern, each shift necessitating that the pattern be levelled up against the previous segment of the mould. If the pattern has been true to the divide of twelve, the space thus left for the twelfth and last segment should be occupied by the pattern exactly, with ordinary care from the moulder during the operations of moulding up to this point: So that with the

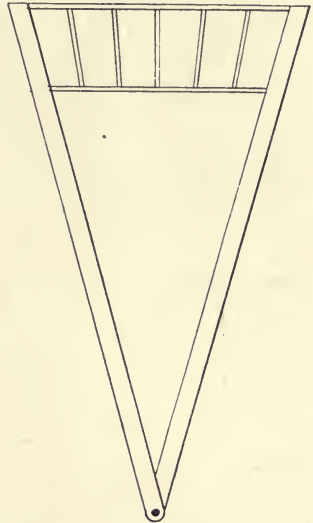

FIG. 82

ramming of this last segment pattern, and the drawing of it, a moulding-box of this description becomes practically completed, and so finishes the job from a pattern-maker's point of view. The cast-iron handles here are the same as previously mentioned; the staking snugs *A* (Fig. 81) are four in number and placed on the inside of the box at a divide of four.

It must be borne in mind that we are only dealing for the present with the general principle, and giving neither section nor details, these being left for others to deal with as circumstances demand.

The pulleys, being practically the model of the bicycle

wheel, the centre and rim are cast separately, so that a separate box for the centre is designed on the "three-part" principle. Of course, the floor constitutes the bottom or drag, the *mid part* is merely a frame with the requisite holes for the spokes, and the top part is a duplicate of the mid part on its sides of suitable depth, say, 5 ins. or 6 ins., and barred across in the way most common to top flasks.

Our last example of moulding-boxes is that shown in Fig. 83, which illustrates a box of four or five parts, as the case may be. If for standard or repeat work, five parts are necessary, but, in a jobbing sense, four parts in all probability would be sufficient, and in which case a "cake" (not shown), to cover the top flange

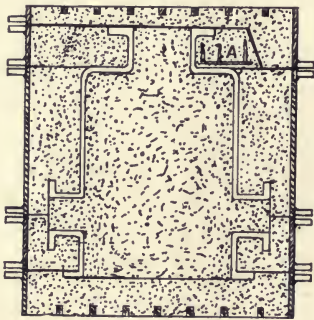

FIG. 83.

of the casting, or a parting and "finger iron lift," as shown at Fig. 83, *A*, would reduce it to a four-part job. Practically there is no limit to the number of boxes for any given job in the foundry, and these are frequently substituted for, by "cakes," etc., and moulding on these lines means not infrequently economy and good practice; but, if a five-part box were adopted for the job that

is before us, provision is made for this, and illustrated on the left-hand side of the figure in question.

In Fig. 83 it will be noticed that the snugs for pins and clamping are shown. These must be on the sides at right angles to the swivels, and "barring" can only be determined according to individual cases or convenience, and thickness or strength of box according to capacity. The deepest part pattern should be made and moulded first, the others in rotation, and, if this be attended to, all the other parts, whether these be in four or five separate boxes, will obviously be made from the one pattern, *plus* snugs, etc.

So far in this subject we have only had space to enunciate a few outstanding principles in flask or box moulding for jobbing work, but the question of moulding-boxes is one of the most

important ones that has to be considered in the economical working of a foundry, and other types will be referred to in subsequent pages.

A slight reference to specialisation in pipe factory plant is again introduced here, but the importance of the subject to people outside this method of moulding altogether, will, it is hoped, be ample apology for what further space may be occupied.

For those that are interested, I should say, first grasp the details of Fig. 84. Sometimes these casings are cast single, at other times double, as illustrated at Fig. 84, and not infrequently do we find them trebled—that is to say, a casing with three compartments, wherein three pipes are handled collectively throughout, thus practically tripling all the movements in

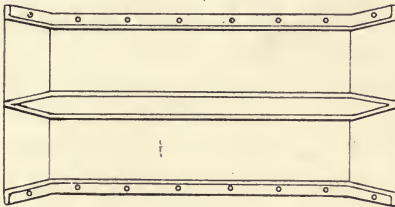

FIG. 84.

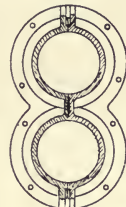

FIG. 85.

the process of moulding and casting “vertically cast pit pipes” in the factory. On the other hand, some hold to “one pipe one casing” large or small; of course, this is immaterial to many, and is of no more importance than the term “pit pipes,” because in some cases pipes are moulded and cast on the floor level of the foundry, in consequence of which the term “pit pipes” becomes a misnomer. Therefore, irrespective of methods the one pipe is equally as good as the other.

Now, as to the making of pipe-casings for vertically cast pipes, there are two methods here also: (1) moulding by pattern, and (2) sweeping them up by loam horizontally; and in the latter process, this must be done with spindle and full length of loam board made to longitudinal section of the pipe casing. Along with the loam board mentioned there must be the odd parts, such as horizontal flanges for binding the casing for its work, and the end flanges, etc., shown in section (Fig. 85).

These with the "rest" for the spindle to work in, with its one, two, or three centres, according to the number of divisions in the casing, covers practically all pattern making for moulding pipe casings in loam. The making of the core is according to common loam practice, and as several times referred to in this work.

Where single casings are wanted, a pattern to mould from is, in my opinion, the easiest and cheapest wherever a goodly number is wanted. But those of an opposite opinion had better perhaps think twice before deciding, where more than one pipe in the casing has got to be considered. Needless to say, pipe casings are cast in halves and bolted together, and the smallest of them should not be less than 1 in. in thickness, with flanges of $1\frac{1}{2}$ -in. metal.

It should also be mentioned that the casing is but part of the pipe moulding-box in a factory, as every casing must have its carriage and equipment, otherwise it is no use for moulding purposes. The casing is fixed to its carriage vertically for moulding, and with the mould finished, it is afterwards run into the stove, and, when dried, is taken out, cored, and cast. After being cast, only one half of the casing is removed at the emptying of the pipe casting, while the other half retains its first position on the carriage awaiting the return of its neighbour for further use, thus showing that the casing, as previously explained, is but part of the moulding-box for producing vertically-moulded pit pipes in the factory.

Factory plant, as illustrated at Figs. 84 and 85, and their indispensable carriages and equipment (not illustrated, but previously mentioned), creates considerably more cost for pipe plant than is common to ordinary horizontal-box moulding in halves. But the superiority of output and, most of all, the incomparable efficiency of the sound and solid castings secured, give to factory-moulded pipe castings a uniqueness truly their own. And the larger diameters cast in this division of pipe founding, when compared with castings of a similar section in other divisions of foundry work, appear to be nothing short of phenomenal, since it is a fact that twelve 48-in. pipes can be turned out in a "shift" in common pipe factory practice.

GATES AND GATING

The term "gate" is always used in the foundry for the inlet or outlet of a mould, the former being to moulders the "pouring gate," and the latter the "riser" or "flow gate." These gates are located about the castings according to their individual requirements as will be seen as we proceed.

The many kinds of gates, and the advantages of gating on the best place or places of a casting form a subject of paramount interest to the moulder. Capacity, location and distribution of gates, together with the proper speed or time taken to fill a mould, cover most of the points which need concern a moulder, while arranging how to "run" his job. The one grand feature about gating a mould is to understand that the easiest and quietest way, compatible with the safety of the mould, is the best way of filling a mould with fluid metal.

Some moulders seem to have the idea that unless their gates be from the highest part or medium depth of a mould, the metal will not find its way to the top of the casting. This is a delusion, because experience has proved over and over again that the best castings, in every sense of the word, are those that have been poured and gated from practically their greatest depths. And, wherever suitable, whether it be in the gating of loam, green sand, or dry sand, "gating from the bottom" as an axiom, with a few exceptions, will work out most satisfactorily.

Gates and Shrinkage.—Besides the speed of filling a mould from the most suitable place or places, the question of shrinkage here again asserts itself, to a greater or less degree, in most castings. With castings that are designed in such a way that they become easily affected by undue heat, gating without due consideration of the after effect in cooling may result in producing scrap instead of castings, as has been too often the case with many a casting thus thoughtlessly treated, the gates in such cases aggravating what was already overburdened by heat, perhaps, caused by excessively proportioned metal. Or, again, it might only be the case of a well-proportioned flat plate, gated entirely from the centre, but

which, in order to bring it out straight and true, should have been gated from both ends of the casting.

Obviously, a plate that is equal metal throughout must inevitably cool from its ends or sides first, and more especially if it be oblong. This being so, the centre naturally remains longest hot, thereby creating a tendency for the casting to warp while shrinking and cooling to atmospheric temperature. Therefore, in such cases, the cure is, undoubtedly, gating from both ends of the casting. Hence we see that wherever irregularity of cooling is likely to assert itself, a judicious distribution of the gates with a view to secure uniformity of cooling is a factor of importance in the shrinking and cooling of castings. Thus far we see that the gates have at times a three-fold function to perform: first, "running" the casting; second, "rising" or "flowing" it; and third, the influence

they exert for good or evil on some castings while cooling after being cast or poured.

Names of Pouring Gates.—

These are too varied for enumeration; all sections or forms having their fancy

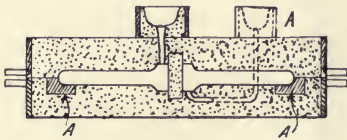

FIG. 86.

terms are but adaptations of some particular "upright," or cut gate, to a certain kind of casting. No matter whether a gate be round, square, oblong, or oval, the important question is that of its position and capacity for filling a mould. However, the names of a few of the pouring gates are technically known as "drop," "cut," "worm" and "fountain" gates, each of the last two being practically the prototype of the other, the worm gate being formed by a pattern as illustrated at Fig. 86, *A*, and the fountain gate invariably cut as shown at Fig. 87. The worm gate (Fig. 86) has a more pronounced "bow-handle" form, but is drawn in its present form for the convenience of clearer illustration than is possible otherwise.

Pouring Gates.—Most moulders look for the heaviest part of a casting for placing their pouring gates, and if they are lucky in securing this, and more especially if it is the centre of a casting, a location of this kind usually means a uniform and safe filling of the mould, when pouring it with one ladle.

Moulds gated in this way are generally considered good practice; hence the importance of gating on the bosses of wheels, pulleys, etc. But although this is the case, it must be borne in mind, that bosses thus gated have more than enough metal here to keep them unduly hot, and by placing pouring gates on bosses, the evil from intense and undue heat in the centre of the casting (which of course means undue strain on a casting that is allowed to cool as it pleases) becomes doubly intensified.

Further, if such a boss be not "cut" with *plates or cores*, be sure that at the earliest convenience the core is removed from the centre of the casting. Likewise expose the boss thus treated to facilitate cooling, as by doing so we minimise the danger consequent on unequal cooling.

It is imperative with pulleys and wheels, and such like, to place the pouring gates on the bosses, but the facts as above stated remain the same, although they seem to be too frequently lost sight of by some moulders, if ever they knew them at all. And

although Fig. 87¹ is illustrative of gating right down through the centre of a boss core, such a method of gating is not, in the opinion of the writer, advisable with castings of this type when much over 20 cwts. in weight, rough in pitch, and also short armed.

Riser Gates, or Flowers.—Either of these terms is quite suggestive of the work these gates perform, since they are to a moulder what an overflow is to every liquid vessel. Still the duty assigned to them is collective, inasmuch as they indicate when a mould is full, serve as a blow-off if need be, clean what otherwise might be a dirty corner in a casting, and

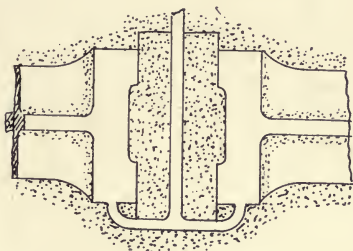

FIG. 87.

¹ The gates or sprues as shown at Fig. 87, are not correct, these are cut at a divide of 2 or 4, as the case may be, on the bottom of the core bearing right into the hub; but for obvious reasons they cannot be so shown in this view.

last, but not least, flow gates are used for feeding a casting, without which, in many cases, castings would be lost.

Flow gates, of course, have their limits : for instance, a mould should always be provided in the aggregate with less "outlet" than "inlet," so that pressure from the pouring gates will be the better maintained than could be possible with gates arranged in the other way. Were flow gates of greater capacity than the pouring gates of any given job, then the metal, if poured comparatively dull, would under such conditions pass up through the gates so sluggishly that in all probability it would begin to solidify in them and never find its way into the basins provided for the overflow of the metal of a mould when pouring.

There is a very general opinion amongst moulders that flow gates or risers check, or at least assist in checking, static-pressure on the cope and bottom of a mould. There is however, very little, if any, justification for this view. The man who would trust to this as a factor in reducing pressure of any kind, and be tempted to reduce the weighting of his job accordingly would undoubtedly find out his mistake when it was too late. With normal pouring, and taking the pouring gates to be maintaining the maximum of pressure, any relief that can possibly come from the riser metal passing through the gates can be of no practical value in reducing the maximum of pressure. Risers and pouring basins as a rule ultimately come to one level, and in any case the risers never can rise above the pouring basins, while the reverse is not infrequently the case. The fluid pressure on any part of a mould depends solely upon the maximum height or head of fluid metal.

Therefore, as vertical height and superficial square inches determine "lifting pressure," the maximum pressure is most conclusively found on that part of the cope which is in most immediate touch with the pouring gates, and remains so if there be not sufficient life in the metal to ebb and flow to the one level, where every square inch in contact with "lift" is equal in lifting pressure, irrespective of gates altogether.

A treatise on gating green sand, dry sand, and loam, separately, would be of much interest, because of the great variety experience has found necessary to employ. But as this work consists of generalities only, we cannot enter upon

the wider field suggested. Nevertheless, a due study of all the propositions of gating that are to be found in this work will doubtless go to inform the reader in not a few of the principles embodied in "gates and gating."

After all, gating with most work is but a part of the successful pouring of castings, one of the principle features being "position," and were this lost sight of, no matter what the distribution of gates on a casting, unsuitable position of a mould while pouring would spell in many cases bad work. For proof of this we find it in cylinders and similar castings, that have to undergo severe machine testing or tooling in the securing of polished surfaces.

Further, gating in the abstract only consists of drop-gates and cut-gates, the former acting direct on the mould, and the latter being cut from some part of a "parting" or joint of the mould, or formed by a flat gate pin, as shown at *A*, Fig. 88; which is to illustrate the gating of a condenser of the dimensions given.¹ In this illustration it is seen at what depth metal can enter the bottom of a mould, and afterwards rise in perfect safety to the highest part, and flow as if it were a

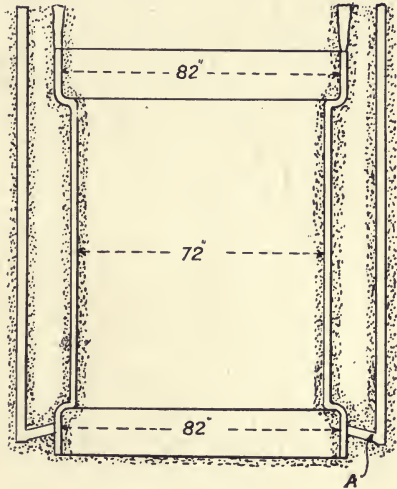

FIG. 88.

case of metal dropping direct in the mould from the highest part. And to any who may have the least fear in running a mould from the bottom, the experience here illustrated should remove all doubt, *i.e.*, when gates are correct in every way, and with metal of suitable fluidity. Under such conditions of gating, and where abnormal depth may be concerned, pouring basins should always be a little higher than riser ones.

¹ The depth of this mould is 12 feet exclusive of basins.

Of course, this is a principle which should be observed in every kind of casting, so that the metal may the sooner reach its maximum of pressure, with every kind of metal with which a mould may be cast.

The "dropping" of metal from gates into a loam or dry-sand mould *that is thoroughly dry*, and if at same time it falls through clear space, need cause no fear to any one. The strength of these moulds, if made from suitable materials, will resist the "drop" with comparative safety, even where the greatest depths of moulds are concerned, *i.e.*, when judiciously supported or finished with sprigs and venting. But with green-sand moulds everything in this respect becomes practically changed. Hence it is never safe to use "drop gates" in green-sand when the space is greater than 1-in. section metal, either in plate or pipe sections, as everything beyond such thickness is positively dangerous. This is most pronounced when immediate "dropping" does not at the same time give immediate covering to the surface of a mould—such, for example, as is experienced in the dropping of metal on the bottom of a wheel boss, or similar contracted space in a mould, and where the bottoms in green-sand moulds are protected for "dropping."

As a rule, the surfaces of moulds can never be covered too quickly with metal at the time of pouring; and this is of more consequence in green-sand than it is either with dry-sand or loam. Green-sand moulds by nature are more gaseous and much weaker than dry-sand or loam, and their tendency to "scab" becomes intensified whenever there is delay in covering the surface of the mould when pouring.

But on the other hand, since a retardation of pouring is essential to the burning out of gases in the core or cores of some moulds, to gate without a due regard to this, would mean the inevitable "blowing" that such careless gating or a want of knowledge in these matters has unfortunately so often produced, not infrequently the result being a bad casting. This class of work being mostly of vertical section, slow pouring with comparatively milky-white metal is generally fairly safe, in so far as homogeneity or freeness from "coldshut" metal is concerned—a thing common to

unduly long or slow pouring of moulds that are cast under normal conditions.

Briefly, the main principles of gating may be summed up thus: first, capacity; second, location; and third, distribution; each of which are important, especially location, because the principle of localising gates on a mould whereby its metal will be admitted with the least possible commotion, and flow through the mould to all its nooks and crevices, gives the greatest satisfaction in the pouring of castings. Therefore, gate wherever possible from the bottom of all moulds, for by this, scabbing is reduced to a minimum, with a consequently better skinned casting, and the purest texture of metal possible below the surfaces and the top sides of the castings. This is specially the case in the usual run of general machinery castings that are cast in green-sand moulds.

DIVISION II

JOBGING LOAM PRACTICE

LOAM MOULDING

IN introducing this subject of loam moulding it might be as well to deal with some of the adjuncts ; not that we can touch on the proverbial hundred and one things which more or less identify themselves with this particular class of moulding, but merely to give a brief description of one or two of the principal tools, such as cross and spindle, shown at Figs. 89 and 90. These figures represent first the cross with boss containing the spindle, thus, X. In making this cross no special pattern need be made ; any apology of a boss giving from $1\frac{1}{2}$ ins. to $2\frac{1}{2}$ ins. metal a-side, and a depth of 5 ins. to 8 ins. will do. Fig. 89 is a sectional elevation of a cross boss, with spindle set previously to casting ; and Fig. 90 is a plan showing a mould as it has been cast and made up previously, by stratagem, according to circumstances. Length of arms may be left for those concerned to determine for themselves, and anything between the figures mentioned for depth will do, and we may say for arms 15 ins. to 30 ins. by 4 ins. by 2 ins. Spindles are made from $1\frac{1}{2}$ ins. to 4 ins. diameter of malleable iron, although the latter size is usually cast iron, and turned all over.

As will be seen the point of the spindle (Fig. 89) is much tapered, and is machined ; but in order to get this a correct fit

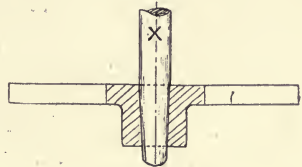

FIG. 89.

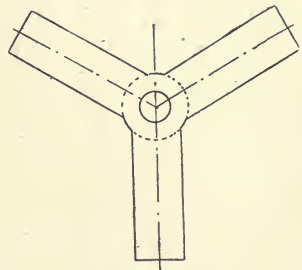

FIG. 90.

it must be cast in the mould as we would a common mandrel, and for this purpose we have to paint or coat the point in question, which will enable the spindle to leave the metal of the boss easily after it has been cast and cooled in it. Many are the *patents* we have seen tried, and some undoubtedly were dealt with as *secrets worth knowing*; but after all, nothing can equal or surpass a judicious application of common tar. Heat the spindle sufficiently to enable it to dry the tar after dipping, then place in the mould as seen at Fig. 89, and cast with comparatively dull metal; the spindle, if the heating has not been overdone but has been sufficient, when cooled in the boss will practically jump out of the casting, if only aided with a little mechanical force. When placing the spindle thus tarred in the mould, see to it that a small piece of the taper is outside of the mould, which is "open sand," otherwise it will be found that the straight part has been caught in the metal.

To the uninitiated on entering a foundry for the first time, it must seem somewhat strange to see a moulder building cope or core, or otherwise engaged in his vocation using his naked hands for mixing and handling his loam as a brick-layer does his mortar with a trowel. All conditions of weather being alike for this, it is no light matter to break the ice and thaw it with a piece of warm scrap before proceeding to build, "rough," or "skin," either cope or core. We do not say that this is the only way of building, but certain it is we never could with certainty create affinity, as known to loam moulders, between loam and brick without rubbing the loam on the latter with the hands in a way practical moulders do. The importance of having absolute affinity, and the necessity of securing freedom from holes or spaces of any kind caused by the shrinkage of the loam joints, must always be borne in mind. Gases will collect in any such spaces that remain and if simply skinned or covered over, will tend to escape by the easiest way, which is through the face of cope, or core, as the case may be. These weaknesses frequently go undetected, the blackwash in many cases being thoughtlessly painted over such cracks, thus making the mould appear all right on the surface. But, on the other hand, the neglected space behind the smooth blackwashed surfaces forms a channel

for gases in such moulds, which are badly dressed previously to blackwashing, and the pressure of the metals not being strong enough to keep these weak parts in check, nasty indentations on the castings are caused by the gases referred to seeking to get out through the metal at the time of casting. Through long practice and observation I have come to the conclusion that all vein-like or groovey surfaces on loam castings, as a rule, are due to the causes stated above. And, may I add, the same effect is produced in dry-sand castings from intermittent soft ramming, or, perhaps irregularities from ramming too big courses; especially is this the case in large dry-sand core making. I have seen those defects as mischievous as a dumb scab in making a bad casting, the amount to be bored out not being sufficient to clean the barrel of the casting.

Therefore, in the building of loam, work for affinity between brick and loam, especially wherever such constitutes the face of the mould. The necessity for this and for absolute density of loam joints, especially within half-brick of the face, give ample reasons for using the hands as referred to in the manipulating of loam and brick, in the art of loam moulding.

It goes without saying that loam moulding as a branch of the trade gives more scope for intelligence than does either green-sand or dry-sand, because, as a rule, no pattern or model is used in its completeness for the production of loam castings. All loam work of cylindrical or spherical section, is always best and cheapest, from every point of view, when "swept" or "streakled."¹ Some have the idea that loam is always the costliest casting to produce. This is so far true, but, in many cases, where the cost of castings is divided between pattern-shop and foundry, much could be said in favour of saving money in the pattern-shop, and spending a little more in the foundry, by making much that is done by sand in loam. Still, where more than one is wanted, and wherever practicable, and plant is suitable, make a pattern according to the necessities of the case and mould in sand. It is also a mistake to imagine that loam practice is confined to the heaviest castings, either on account of cost or the limitations of

¹ As previously stated.

practice. Hence it is that some very small castings are both of necessity and for economy made in loam. Loam may also have to be resorted to, because of extraordinarily heavy metal, and when a superior job is wanted, as no material for iron-moulding is so refractory as good loam. Again, no mould of great importance would be as safe in sand as is possible with loam; consequently, such castings as the great bell of Moscow, whose weight is given at 423,000 lbs., and whose thickest part is also given at 2·3 ins., circumference near the bottom 67 feet, and height 21 ft., would undoubtedly be a loam mould. No mould of any other material can be kept so long in safety, and under normal conditions of material, treatment and security from damp; and with neither frost nor an excessively moist atmosphere, no one need be apprehensive of danger at the time of casting any job, the time for which was unduly prolonged, while closing and preparing for casting.

Although loam moulding, as has been said, gives greater opportunities for intelligent foundry practice, it is by no means the branch of moulding to which apprentices should be first put, the reason being that nothing but sand can cultivate that nicety of touch in handling the tools which goes to make a good moulder. Also the control of sand ramming, according to degrees of fluid-metal pressure, which is so variable from the bottom of a mould upwards, and the variation of force in the use of the rammer on each successive course in the ramming up of a job to secure its safety from scabbing or swelling at the time of casting, are, together with the best texture of sand possible for venting, vital factors in the production of sand-moulded castings but rarely met with and indeed not necessarily thought of in loam moulding. Obviously the principles of moulding are not taught with the same force in loam as in the case of sand moulding, and specially is this the case with all classes of heavy green-sand work. Therefore, all apprentices should have a good deal of practice on the floor before being put to loam—that is to say, if the best training possible for making a first-class jobbing moulder be aimed at. All after this are points of detail which can only be mastered by long, thoughtful and

observant practice. Now, the prime object of this division on loam moulding is to assist those apprentices or sand moulders, who may be inclined for knowledge in this branch of the trade. By a study of the foregoing, and the short series of articles to follow, they may equip themselves for the future, should they at any time be called upon to make a simple piece of work in loam, but what follows is in no way intended for men of experience in this class of work.

MOULDING A 36-IN. CYLINDER-LINER IN LOAM

A 36-in. cylinder-liner (Fig. 91) is one of the simplest jobs in loam, and the following directions based on the writer's practical experience as a moulder should, although somewhat summarised, be quite sufficient to enable a sand-moulder (dry-sand) of usual ability to make the job, even if he has no experience at all in loam. There would be nothing intricate about the job were it in sand, but the idea of going to a "bed" and drawing-off the plant of the smallest of jobs undoubtedly appears to be a difficult problem to many moulders who have had no experience in this class of work.

Let the uninitiated try to remember that the first thing to do is to "draw-off" the job and all will come right. The difference between drawing-off and using a pattern for the same operation in the foundry is as that which belongs to a mechanic in "drawing-off" from a drawing as against finishing the same article from a template.

Fig. 92 represents the bottom plate as drawn off before proceeding to mould. For this figure, every straight line and circumference is drawn to represent the job in every detail of measurement which is thereon explained. The diameters of core and cope are first put down—that is to say, after the four cardinal points (Fig. 92), which represent the handles, have been squared, and from which all other attachments are calculated. A keen grasp of what is here stated gives the key to all requirements in "drawing off," not only for this job (Fig. 91), but for loam moulding as a whole.

From *A* to *A* (Fig. 92) is the centre hole for the spindle to pass through, and perhaps a convenience for clamping the spindle-

cross as well. *B to B* gives diameter of core, *i.e.*, 36 ins. *C to C* shows thickness of metal on body of casting as $1\frac{1}{2}$ ins. *D to D*

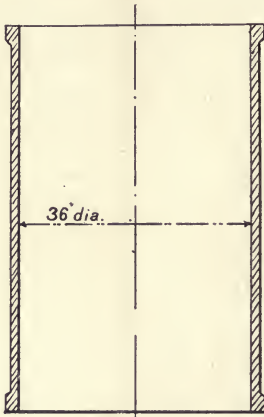

FIG. 91.

is the facing belt at both ends of the liner casting. *E to E* is clearance for cope ring, and space for parting inclusive. *F to F* shows breadth of cope ring, *viz.* 9 ins.

For the moment let us view all parts from the pattern shop, such as sweeps and gauges for cylinder-liner (Fig. 91).

Fig. 93 is the bottom bearing sweep, Fig. 94 top cake sweep for Fig. 97, which is the top part for this job. Figs. 95A and 95B are the cope and core gauges. Fig. 96, *A* shows the core board attached to the spindle, and *B* of the same figure shows the cope board in a similar position. The above constitutes all cost of pattern making for this liner casting, not a very costly affair indeed.

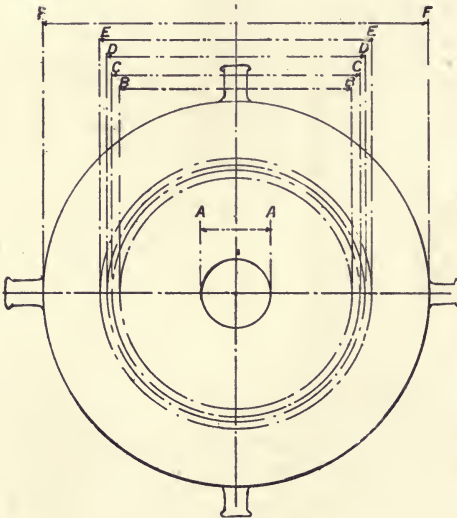

FIG. 92.

In Fig. 96, with the exception of the top cake (Fig. 97), and for convenience of illustrating, there is shown in sectional elevation all connected with the building of this liner casting as

seen at Fig. 91; and to those specially interested, doubtless, a study in detail of Fig. 96 will be profitable. Again, in Fig. 96 is seen the cope completed with its sweep or streakle board attached to shear irons *D*, the board of course being set with the gauge stick (Fig. 95A). *CCC* are the building rings and are interspersed throughout according to fancy—some would say every four courses of brick, others might say eight; it is all a matter of opinion, and, as a rule, does not matter much, provided the top and bottom ones are placed right, *i.e.*, the bottom one for suitability of clamping, and the top one previously to building the last course of brick.

On the left half sectional elevation (Fig. 96), is likewise seen the core representing a finished job in so far as building, roughing, and skinning are concerned. The board *A* looks a little slender and is suggestive of weakness and is thus apt to get out of truth for finishing to size correctly. Therefore, care must be taken to prevent this by the most conveniently safe appliances at hand. *E* (Fig. 96) is one of the cope handles, but a better view of these is seen in Fig. 92. It will be noticed that the parting of the cope is denoted by a heavy black line (*K* and *H*, Fig. 96).

Now the method of building is to make this core a fixture to the bottom of plate *F* (Fig. 96); consequently after striking the parting, and when it becomes stiffened, we proceed to set the board *B* and build the cope on the ring *E*. The cope being built, "roughened" and "skinned" by sieved loam, must have time to stiffen before removing it to get on with the core. This being done we now set up our loam board *A* and proceed with the core, as seen on left-hand half sectional elevation (Fig. 96). A careful look at this figure, paying special attention to the core, should afford all the information necessary to a practical man, and

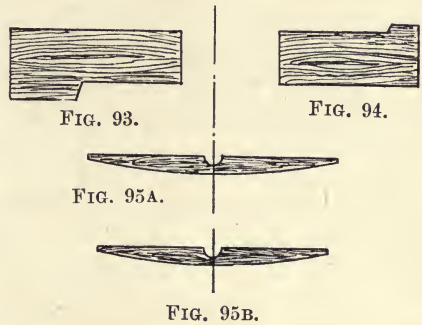

further reference to it would be superfluous, except to say that the three uppermost courses of brick should be tied with wire to keep the whole from warping or twisting while drying in the stove.

The practice of setting a loam board is to many a little troublesome, and it goes without saying that the man who cannot do this has no claim to call himself a loam moulder.

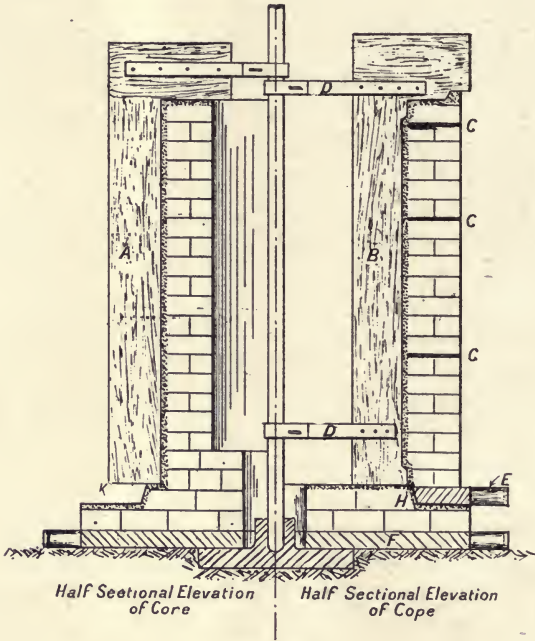

FIG. 96.

Many good underhands, the bulk of whom were originally sand moulders, have had but little, if any, chance to acquire the ability to set a loam board which is always done by the man responsible for the job. In view of what is stated here we shall give an object lesson on this particular point, and for this purpose we take the top cake plate of the cylinder liner (Fig. 97). Taking this top cake as a study for the job in question we will consider it as having half a dozen gates, two of which may be used as risers; the rest will be clear

enough for all practical purposes. In the setting of this top cake board (Fig. 97), and assuming it to be a good fit, it ought to be kept clear a little, so as to make it enter easily when closing on its place shown in Fig. 96. In Fig. 97 the plate is shown arranged in position with the cross *C* and its spindle, thus, *X*. The shear iron *D* fixed to the spindle has the streakle board (Fig. 94) attached to it and is held in position by the aid of two or three bolts, as shown in the illustration.

Fig. 97 represents the gauge stick as setting and proving the board (Fig. 94). It will be noticed, on the left of Fig. 97, a piece of clay *B* has a brad fixed in it almost in touch with gauge stick (Fig. 95A). Assuming our gauge to be on the right on the side opposite to the brad, and endways against the nipple *K*, secure the brad against moving in any way, then come to the brad with the board (Fig. 94), and the

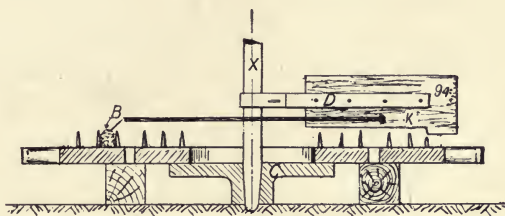

FIG. 97.

brad being temporarily fixed, it is pressed gently in touch with the gauge stick, as shown at Fig. 97, and if the board be parallel to the plate and give a level surface, such a setting of the board as here described must produce the best workmanship possible. It frequently happens that a first or second attempt is a failure, but with the board level with the plate lift the gauge, hold it firm against the spindle and as firm against the nipple *K* of the board, as shown at Fig. 97, and while in this position bring the brad again in touch with the other end of the gauge; this done, tighten up the board, remove the gauge, and bring the board round again to pass by the front of the brad with an infinitesimal clearance, and, if this be secured, the board is completely set, and with the roughing of loam, and the finishing of this top cake (Fig. 97), the moulding of the cylinder liner (Fig. 91) is so far completed.

MOULDING A SLIDE VALVE CYLINDER IN LOAM

With this casting, as with all other loam work, our first concern should be to see and study the drawing, and get it well thought out before starting the job in any form whatever. If working from a drawing, we must be careful about our sizes, and should there be a full-sized drawing about, then the right place for it is the foundry after the pattern shop is done with it. Formerly, in the best-organised districts, all loam work was accompanied by full-sized drawings for the foundry and all thicknesses in section painted black; this has now to a very great extent been displaced by the "blue print," so that the moulder's capacity for reading drawings requires to be of a more intelligent order in these days than was the case or was necessary in the days of his predecessors.

Assuming the "face" (Fig. 98, *A A A*), which consists of the steam ports and casing, is all one piece, and loam boards, etc., are ready, we now proceed to cast the plant. But before starting to do so, let us throw our mind's eye back on Fig. 92 for the guiding principle of this operation. This comprehended, all else will assuredly follow. Having found our greatest sectional plan (Fig. 99), which is through the exhaust branch and centre of casing, we have got the key for "drawing down" the bottom plate (Fig. 99). As will be seen in studying this figure, there is first drawn down the casting in full section, with the usual clearance of $1\frac{1}{2}$ ins. from the casting, as shown in Fig. 99 and previously explained by Fig. 92; then add other 9 ins. all round as shown, and square corners for convenience of handling, as also seen in Fig. 99, and by putting the handles in their places, as shown with dotted lines in same figure, the bottom plate is completed for the cylinder (Fig. 98) in so far as the drawing down is concerned.

Again, Fig. 99 is drawn down first with the intention of showing the building rings, and the two snugs *A A* of this figure are cast on for the purpose of binding the rings after

they have found their place on the building (Fig. 98, *C C C*). Again, in Fig. 99, if after drawing the circles and straight lines which go to make the plan or section of this job, we also

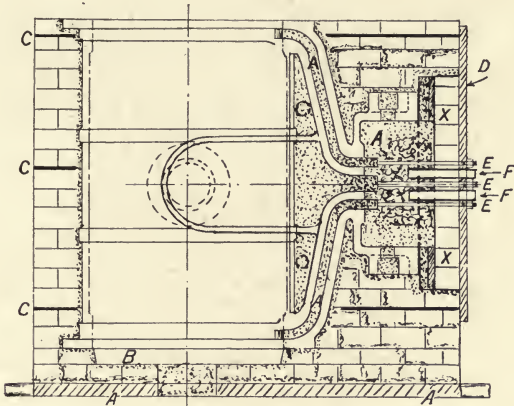

FIG. 98.

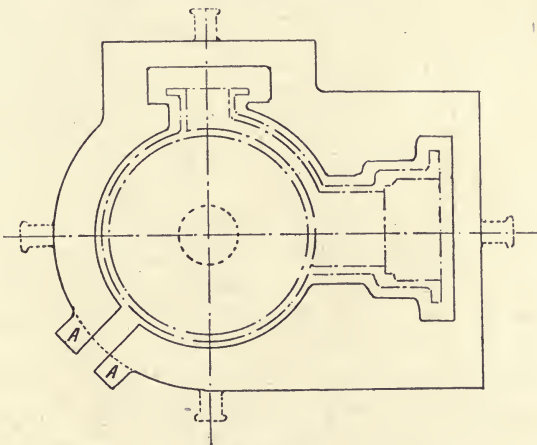

FIG. 99

draw in clear lines what is dotted, then fill up snugs *A A*, the bottom or base plate will be made as it should be. Thus we illustrate building rings and bottom plate in Fig. 99; indeed, this section in its outside measurement is the same for all plates or rings cast for this job, from the base upwards

including the top cake, not necessarily shown. Therefore the top cake is practically the same for measurement as the bottom plate, but a larger hole in its centre will suit better, so as to give 6 ins. a-side for "stamping" the main core at the time of closing. Of course it must be daubed and gated similarly to Fig. 97, *i.e.*, if the metal drops through clear space to the bottom of the mould.

The building plant for this cylinder thus briefly detailed should, together with what instructions were given in connection with Fig. 92, give the uninitiated in loam moulding a fair amount of knowledge in how to proceed with one of the most important parts of loam moulding.

It will be noticed that in the selection of Fig. 98, we are taking a step in advance of the cylinder liner, with which we began, namely, Fig. 91, and as we somewhat fully stated the preliminaries of starting to build loam work then, we consider it unwise to go over the same ground again. Consequently a sectional elevation



FIG. 100.

is given in Fig. 98, which shows all material in section, and presents to one's view a fair idea of what it is we are trying to impart to others, with as little repetition as possible. Hence the avoidance of cross, spindle, boards, etc., in demonstrating the method of moulding a slide valve cylinder in loam.

material in section, and presents to one's view a fair idea of what it is we are trying to impart to others, with as little repetition as possible. Hence the avoidance of cross, spindle, boards, etc., in demonstrating the method of moulding a slide valve cylinder in loam.

In the first place it will be noticed that the entire cope is represented as being built fast to the bottom plate *A* (Fig. 98); but before this can be done we had better form the bearing *B* with the sweep board (Fig. 100) and build the main core, otherwise we should require to mould a "false bearing" and make the core apart from *Fig. 98 altogether*—not a very commendable way indeed. Therefore we take the sweep board (Fig. 100) and form the bearing *B* (Fig. 98). This being done and stiffened, we fix up the core board, not shown, get the barrel core built and finished, and then afterwards removed to a convenient place of safety. We next proceed to the building of the cope. Building plate *A* and cope rings *C* are just the same, practically, as before stated. But, in building the bottom part of this mould, build as dry as is compatible with efficiency, so that

drying the mould at this part may not be unduly prolonged. Sufficient instructions for the building of the main core for the cylinder (Fig. 98) will be found by reference to Fig. 96 (half-sectional elevation *A*), adding an ordinary core iron with three 1-in. eyes cast in it as lifters, and a "bearing" formed, as illustrated in Fig. 98, *B*.

The sectional elevation of Fig. 98, as will be seen, represents the small cores all in position, with the mould ready to receive the main core. The small cores give much matter to enlarge upon, such as the making of irons for them, and the materials of which they should be made, venting, and how they should be dried, etc., all of which are absolute essentials in core making, but which it is not advisable to deal with here.

However, a short description of the method of placing the cores in position, as illustrated at Fig. 98, may be of advantage.* And, to begin with, let it be observed that *D* (Fig. 98) is a vertical bar to which the cores are bolted. The first core to be placed is the casing, which had better be made quite secure by bolting to *D* (Fig. 98) as shown; this done, we have a

good foundation for the rest. The bottom port is then secured, and tested for clearance with gauge stick (Fig. 101), so that no mistake may happen when the main core comes to pass by it on its way to the bottom print *B* (Fig. 98) when closing. The top port *A* is next placed in the same or similar fashion. These ports being thoroughly secured and tested in every way, and this part of the mould being likewise cleaned out, the exhaust core is put in, which completes the most difficult part of coring a slide valve cylinder of any dimensions. Fig. 102 shows the exhaust core to be cut in two or three pieces (*A* and *B*), but usually it is cut at *A* only. Of course this is only necessary



FIG. 101.

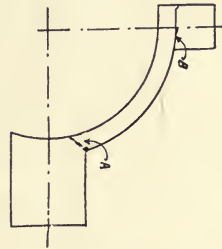

FIG. 102.

* *EEE* are the bolts which secure the small cores to the bar *D*, Fig. 98.

when the cope is built all in one piece. The exhaust core being fixed, and whether made with one or more joints (as seen at *A* and *B* Fig. 102), to fake it matters not, it ought to be chapleted top and bottom where jointing takes place. If this be attended to, chaplets in such cases serve a double purpose by keeping the core in its place and guaranteeing to a certain extent the safety of any of the faked parts from lifting or starting in any way at the time of pouring. *F F* (Fig. 98) are the vents secured and daubed with loam all round the joints of the steam ports and exhaust core inside the casing core. Great care must be taken to secure the metal against getting into the vents, and when satisfied as to this, thoroughly clear out all vents, then pack the space inside the casing core *A* with suitable ashes, and insert tubes as shown (Fig. 98, *F F*). This done, it will be seen that all vents are collected to the casing and discharged collectively through the two vent tubes *F F* (Fig. 98).

MOULDING A CYLINDER COVER IN LOAM

Whether such a cover as represented here (Fig. 103) is cheapest and best, it matters not for our purpose. Large or small, the principle is the same, except that the plates *A* and

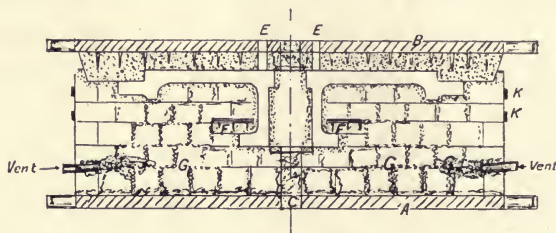

FIG. 103.

B will require to be thickened in proportion as the diameters increase, although those plates are seldom cast above 3 ins. thick.

Figs. 104 and 105 are the loam boards, which explain themselves, but to draw off, cut, and finish these boards requires one with some experience in loam work. It will be observed that the section of metal is shown in Fig. 104, so as to assist

in making it clearer to those who may not have experience in this class of work, and before proceeding to use them in the foundry they had better be proved by comparing the one board with the other, and thereby prevent any possible mistake happening. The little nipple on the boards, thus, , are to steady the size or gauge sticks when setting the boards, and should be used on all loam moulding boards. In the sectional elevation (Fig. 103) we have a fair representation of the mould in its completeness preparatory to making it ready for pouring. *A* is the bottom plate, *C* is the spindle-hole (rammed up with sand), which may be any size compatible with safety for the bottom of the casting. The fixing of the spindle with its cross is not shown, but must be taken for granted to be as usual,



FIG. 104.



FIG. 105.

while the hole should be larger than shown at Fig. 103, *A*, so that the clamping of the cross may be easily got at if need be.

The top plate *B* of this figure shows two pouring gates *E E*, and it must also have a 3-in. or 4-in. hole in the centre for working the spindle. Sometimes these covers are gated round the circle, and "flowed" by risers in the centre. The latter way of pouring, however, in my opinion, creates unnecessary work, and I never knew of anything going wrong by gating in the centre instead.

This would be quite a plain job but for the stuffing-box flange, which necessitates the use of a "cake" in halves *F F* (Fig. 103). This does not present any unusual difficulties, and of course there are various ways of moulding it; but whatever way we choose, the tongue *K* of the loam board (Fig. 104), which forms the flange of the stuffing-box of this cover, had better be detachable.

In commencing to build, the spindle is put into position as shown at Figs. 96 and 97, and the first course of brick is merely bedded down on loam, leaving all joints except the outside course to be packed with dry ashes, as illustrated at

G, Fig. 103. In the building of loam moulding some have a strong inclination for all parts next the casting to be done with loam brick; others are not so particular, hard or soft all seem the same to them. The latter, in my opinion, is by far the better practice for more reasons than one, and specially is it so when surfaces or projections are considered. But for vertical parts such as illustrated by cylinder and liner (that is to say, the open parts), hard brick becomes the indispensable article of construction. So, then, the first course of brick being laid for this cover (Fig. 103), and the ashes packed between them, our next course should be loam brick, at least on what is to form the face of the casting, which is the flange of the stuffing box in this particular case.

In forming or sweeping this flange, we should endeavour to strike only the bottom and sides, which only need to be roughed and stiffened. With the flange thus prepared we now place on top of it, the rough dried cake of loam in halves (Fig. 103, *F*), and with sufficient clearance for the tongue *K* of the board (Fig. 104), to get working, and at the same time making it good for skinning as well. When building this class of work we must keep down as far as possible wet joints, both for drying and venting purposes. In Figs. 103 and 112 the zig-zag joints in their structure, show in a way the ashes placed between the joints of bricks for the double purpose of drying and venting. These covers and similar work are usually cast without pitting, as known to loam moulders. Figs. 103 and 112, *K*, represent two bands of hoop iron encircling these copes, just as malleable hoops would a barrel, and when looped at both ends with annealed wire and fastened firmly, no danger from pressure under normal conditions at the time of casting is possible.

CORES AND CORE IRONS FOR A SLIDE VALVE CYLINDER.

When describing, in the section on "Moulding a Slide Valve Cylinder in Loam," the method of placing the cores, only a brief reference was made to the materials used and the methods of making these cores and core irons. In order, therefore, to preserve the continuity of this subject, the making

of core irons and cores for such a cylinder, will be considered more fully, the details given being all that should be required for this particular method of moulding the cylinder in question. It must be understood that what is given here is intended to fit into the existing circumstances of an ordinary jobbing moulding shop, and where specialisation in this sort of work exists other methods may be used, and prove

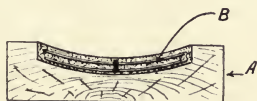

FIG. 106.

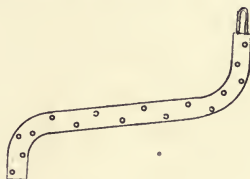

FIG. 107.

superior practice. The core-boxes are only shown in sectional view along with the cores, and thus have not the completeness desirable, but there should be enough in the accompanying figures to show how best they may be made in view both of good practice and economy, especially as regards economy in conjunction with the pattern shop.

In Fig. 106 we have the steam port core-box in section along with its core iron *B*. Fig. 107 shows the plan of port core iron, and the dots interspersed indicate malleable irons, thus ribbing



FIG. 108.

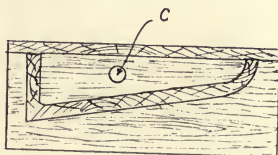

FIG. 109.

the core iron as shown at *B*, Fig. 106. Fig. 108 is the sweep with a check on its right-hand side to keep it in its place while working along the edge *A* of this core-box, thus forming the hollow side of the steam port core-box, and, the section of core-box being shown, no other information is necessary for making it. Fig. 109 shows lightening core-box with plug hole *C* for venting and fettling purposes. The simplest way of making

this box is to cut two pieces in section and line up this to the proper length, and with a flat board screwed on as seen in section (Fig. 109) we have a complete core-box with very little cost. The plug-holes (Fig. 109, C) had better be carefully marked on the mould and core, and the vent ways made good and clear for the escape of gases. By this it will be seen that the plug-vent cores *C* are made separate; this being so, on the placing of these lightening cores, the plugs find their places in

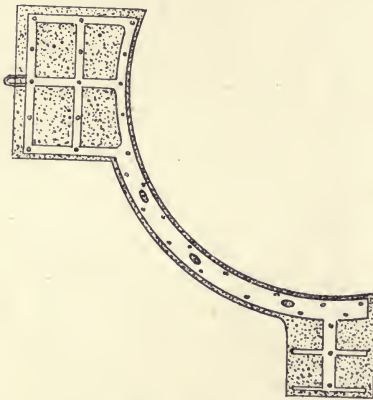

FIG. 110.

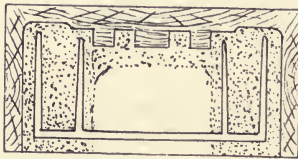

FIG. 111.

connecting themselves by provision being made for vent-tube arrangements through the mould. This method is easy, simple, and safe, and gives means for the rapid exit of gases from the lightening cores, as seen in sectional elevation (Fig. 98). These vents are indispensable for fettling purposes as well.

Fig. 110, shows a sectional plan of exhaust core and core iron, and represents the handiest way of making this core-box and core, minus the round branch, which may be made from an ordinary "stripping" piece or ordinary round core-box of the required

diameter. The dots again in Fig. 110 represent malleable irons cast in the frame, which is a single iron, stamped from the impression of the core-box. These malleable irons should be zig-zagged, for by doing so we secure nice space for venting and bonding the core. Also, these malleable irons must be fixed in the core-iron mould previously to casting it, with $\frac{1}{4}$ in. clearance a-side, according to ordinary core-iron practice. Further, we must not forget to examine our conditions of

moulding a cylinder with this core, so that we shall know whether to make it in one or more parts as previously explained in Fig. 102.

In considering the section of the casing core in the box (Fig. 111) it must be seen at a glance that this core is made in its box conveniently. Sometimes it is built, and, instead of being shown with one core iron, as seen at Fig. 111, not less than four, if illustrated, would be seen when built vertically; and when other things are equal vertical building of casing cores is, in our opinion, the best, no matter from what point of view we take it.

But, in Fig. 98, the face is represented as being done with a cake, and this being moulded true to the parting of same, we

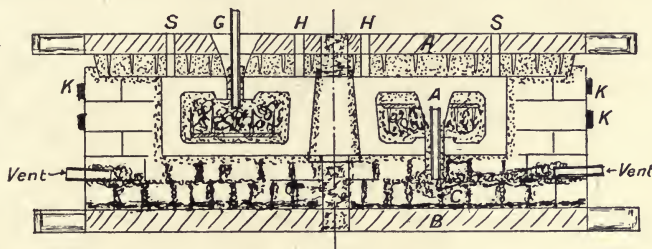

FIG. 112.

bolt casing core to face plate and lower both together into their places, as seen at Fig. 98, arrangements for which must be made at time of building the cope. Needless to say, no patterns are required for making these core irons except for the steam port (Fig. 107), and which ought to be made a little less in section to admit of loam for clearance of core-iron casting, or, according to usual core-iron practice, as previously stated.

MOULDING A PISTON IN LOAM

For the sake of simplifying matters we shall keep very much on the lines of the cylinder cover (Fig. 103) with this piston (Fig. 112), and the better the former job is understood, the easier will the moulding of a piston in loam be made. Moulding plates, top and bottom (Fig. 112, *A* and *B*), of this job are practically the same as the cylinder cover (Fig. 103),

less the holes for venting and fettling, common to all hollow piston castings. The pattern pieces of this job are here given in detail. Fig. 113 is the top board for the top cake; Fig. 114 represents both the bottom of the mould and the thickness board for putting sand to the thickness of the metal on the face of the mould, thus preparing it for making the cores as seen on the plan, Fig. 117. In Fig. 114 the hatched lines indicate thickness of metal which can be cut away and used as the thickness board after the bottom of the mould is finished, if thought advisable, but the better way is to make a board for thickness purposes alone. Fig. 115 is the plug-hole core-box, which serves the purpose of venting and fettling out these cores. These plugs are usually fixed on the cores at the time of dressing, preparatory to blackwashing. So much for



FIG. 113.

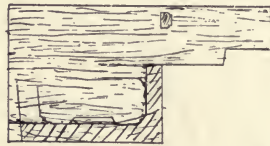

FIG. 114.



FIG. 115.

details. We pass on to say that, after the spindle has been fixed and loam board (Fig. 114) set for moulding, there is nothing very special for consideration but venting. In regard to this point, the first course of brick should be ash jointed, as shown in Figs. 103 and 112, but in the next course, which is next the face of the streakle board (Fig. 114) and if the vent-plug cores must be in the bottom (*the most undesirable side by far for the moulder*), a circle of ashes as shown in Fig. 112, *C*, becomes imperative, so that when coring the job the face of the mould may be tapped anywhere down through those four cores, as shown at section (Fig. 112), and thus catch the plug-vents at any point. This circle vent is led out by branches three or four in number, or more if required (see vent, Fig. 112). Wherever venting from the bottom is imperative, an extra course of bricks with ash joints becomes advisable, thus facilitating the venting of gases in these piston-cores.

As is well known, much danger is at all times connected

with the casting of hollow-box section pistons, and of course the greatest trouble arises from the cores. Consequently, we cannot be too careful in all that pertains thereto—first, as to the material with which the cores are made; second, the necessity of proper baking or drying. These cores being enshrouded in metal and no escape for the gases but by the plug-holes, it becomes imperative to burn as much of the vegetable matter out of the cores as possible, and as is compatible with their safety, so that the accumulation of gases from these cores is brought to the minimum. As has been said, there is but one way of escape in general practice for the gases from the cores, viz., through the individual plug-holes. There is no reason why this should be so, as by a little ingenuity all cores can be made inter-communicable, and by doing so, should any mistake occur



FIG. 116.

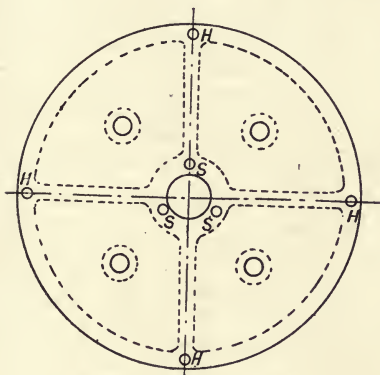

FIG. 117.

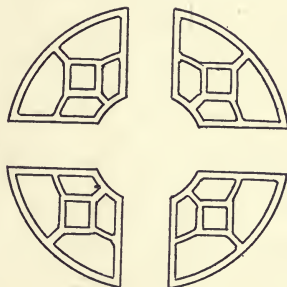

FIG. 118.

at time of casting by reason of one or more plug-vents becoming choked, the gases from such a core or cores would escape through the cores right and left of the one whose vent had become choked. Clearly we see in such an arrangement as this that the danger of losing the piston becomes minimised, for undoubtedly many a good hollow piston casting has been lost by "individual-venting," for which collective-venting can be easily substituted.

Fig. 117 shows the position of the cores as they are placed in the mould when closing, and Fig. 118 is a view of the core irons as they *may* be cast. These core irons are drawn off on the bed by square and compasses, and are formed by "stamping" according to the judgment of the moulder. However, the purpose of Fig. 117 is to show the cores in position, and it also serves to show the plan of the top cake, which in some cases is a duplicate of the view we have here, plus whatever more may be required for posting on joints. Make the holes for vents, as seen in Fig. 117, large enough to admit the plug-cores to pass up into the prints, as seen at *G*, Fig. 112, so that the securing of the vents by telescoping tubes into the cores, or otherwise if thought better, may be the safer effected. The same way of telescoping vent tubes must be religiously attended to when plugs are down through the bottom of casting, as seen on right hand of Fig. 112, *A*.

Three or four gates *H H* on the boss are quite sufficient for running, and four flow gates for risers *S S* (Fig. 112) should suffice for castings of this size, and up to a considerably larger diameter.

LOAM MOULDING IN BOXES OR CASINGS

The item of "pitting" with loam moulding is always of serious concern in the cost of production, and but for this much that is done in sand would be made in loam. Although, in open floor work, as shown with covers and pistons and such like, moulds are made, as seen in Figs. 103 and 112, where hooping *K* is all that is necessary for security of pouring, yet these are not the only exceptions to the rule of pitting, and its consequent cost in loam-moulding. Much work is also done by faking with plates and daubers, both for vertical and horizontal moulding, especially as it is practised in the loam "specials" departments of pipe foundries.

As has been previously mentioned, loam work is frequently resorted to because of the want of plant and pattern, but where the former may be at hand without the latter, there is no reason why we should not use the plant and substitute loam-boards for a pattern, such as has been advanced for cylinder-covers and pistons in this chapter on Loam Moulding.

Therefore, in connection with this method of working we show in Fig. 119 the same piston as Fig. 112, moulded in a box in loam. The sectional elevation of this (Fig. 119) shows everything in position, and ready for the metal. *A* is the spindle cross, but, before placing this in position, our first duty is to ram a course of sand in the bottom of the box as shown. This done, we fix the cross, get the spindle adjusted, set our loam board and build on one course of loam brick as seen, and so on, according to our experience of this sort of work, all of which has been explained in connection with Fig. 112. *B* is the moulding-box, *C* is the top cake, *D, D, D* are risers and pouring basins, and *E, E* are

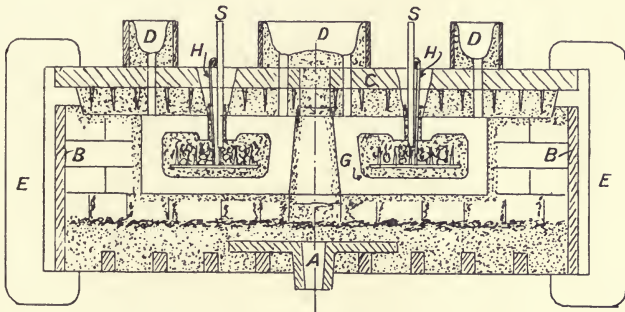

FIG. 119.

the clamps for binding the job; *G* is the core, *H H* are short pieces of iron by which the cores are suspended to the top cake, a method in most cases commendable, and which does away with chaplets for carrying cores on the bottom of mould. *S S* are vent tubes.

In some cases we have used a flask for covering such a job as seen at Fig. 119, but the trouble of catching all vents clear of the bars of the boxes in question makes in most cases the top cake *C* (Fig. 119) the best and cheapest in the end.

This short summary of making a piston in loam by using a box as a casing shows the advantage of this method when compared with that illustrated by Fig. 112. By such practice the building gives less work, hooping with iron or pitting is done away with, and where a repeat is wanted we have an

approximate saving of 75 per cent. of the cost in building the bottom part of this piston mould. Besides, this as a mould is much easier slung and handled in every way; many advantages are thus gained when moulding loam in an ordinary moulding-box, as illustrated at Fig. 119. For reasons which may be obvious the vents are not shown secured, but are intended to be done in the usual way by first securing the

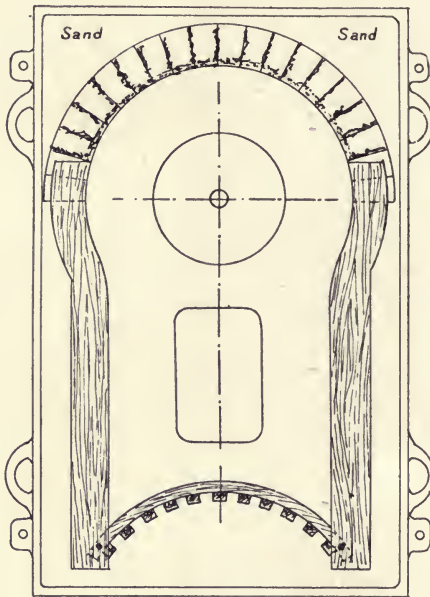

FIG. 120.

space with "waste," then afterwards ramming all space, as seen at *H H* (Fig. 119), with rock-sand.

MOULDING A 20-IN. LOCO. BOILER-FRONT CRESS-BLOCK IN LOAM.

In this our second example of moulding loam work in a box, we have an article of great importance for the boiler-maker, for, just as his cress is free from disfiguration of scab or swelling, so in like manner will the contour and finish of the face of his job be perfect. Looking at the plan and section

of this boiler-front cress (Figs. 120 and 121), it will at once be seen that for such a plain casting the cost of pattern must be considerable, *i.e.*, when it has all to be put on to one casting, as is very frequently the case, especially in the smaller loco. building shops of the country. But, apart from this altogether, a loam casting, we should think, is imperative, because the exactitude of curve and surface for the boilermaker to cress from cannot be equalled with either green-sand or dry-sand castings—the former being bad practice under the most favourable circumstances imaginable. From an economical point of view this job, weighing, say, 16 cwts., is pre-eminently a desirable one for making in loam, not only for reduction in cost, but in the saving of a pattern, and it is no exaggeration to say that for all parties and purposes loam moulding

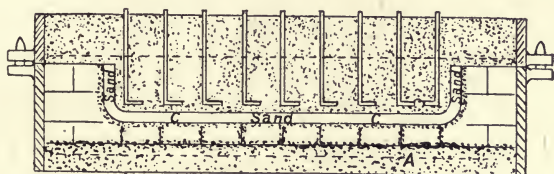

FIG. 121.

for this class of work is the ideal way for economy, and good workmanship. In short, this casting ought to be produced for about half of the money required to meet the cost of a pattern, and were two moulded instead of one (not necessarily of the same dimensions), the cost again becomes considerably reduced, thus showing a case in which a loam casting becomes the cheapest in the wages book of the foundry and pattern shop as well.

In viewing Fig. 121 it will be observed that everything is shown in section as the job stands rammed up, before parting it for finishing. Let it be taken as matter of fact that the bottom-box is on its back ready for starting. This admitted, our first move is to get the spindle (not shown) fixed up for proceeding to build, and afterwards ram a course of sand *A* as the foundation of the job. This sand being rammed abnormally hard and of uniform thickness, we

bed in two straight edges, not shown, for the purpose of levelling the flat face of the mould beyond the reach of the area swept by the circle Fig. 122, at the round end of the casting. The whole surface being formed by the aid of these straight-edges and sweeps (Figs. 122 and 123), we next build round



FIG. 122.



FIG. 123.

the circle end (Fig. 120), and form this end of the parting complete. At this point, bottom and circle end being now swept, these must have time to stiffen or dry, to admit of the parts shown in Fig. 124, right and left, along with Fig. 125, being placed into position (Fig. 120), which completes all outside measurements of the casting.



FIG. 124.

It will be noticed that those two flat sticks (Fig. 124, which it will be recognised serves to illustrate both) are placed to determine outside size of casting, and also serve as guides or rails whereon the sweeps (Figs. 122 and 123) move along when sweeping the bottom of mould which forms the outside or face of casting. Sweep (Fig. 122) being used for faking round the corners where the other sweeps cannot reach, the joint guides, right and left (Fig. 124), are held in position by a screw nail at the circle end as shown in Fig. 120, and of course weights are applied at the opposite end for a similar purpose. Those details bring us to the point of finishing off the entire face of the mould and parting, inclusive of everything pertaining to the drag

or bottom of the casting.

Before proceeding further, we must first satisfy ourselves that the drying of the mould is firm and rigid; afterwards put thickness of metal on with sand by the aid of the sweeps (Figs. 122 and 123), in a style similar to the formation of the bottom of the mould; these two sweeps being used to

form the face of the mould, the thickness of metal is formed by reducing them to the dotted lines. A reference at this point to Fig. 121 shows in section the thickness of metal formed by sand. Having now got our thickness formed and slightly coated with parting sand, our makeshift pattern is complete. Next, put in sand for hangers or gagers, then put on the top part or flask and ram up in the usual way, thus showing the job as it stands at Fig. 121.



FIG. 125.

Briefly, we now proceed to part the job and finish. The thickness sand *C* (Fig. 121) being removed, the design, as shown here also, can easily be "faked" without the aid of core-boxes by the moulder, and, if need be, without any aid from the pattern shop at all.

THE USE OF ASHES AND DRY-SAND IN LOAM MOULDING.

There are men who are good and successful moulders who do not in any way recognise the utility of using dry ashes in building loam work. Such men stoutly advocate that to apply dry ashes, as has been indicated in this section, tends to hinder rather than help the drying of such work in loam. They assert that the steam generated from the adjacent wet loam joints of a mould condenses amongst the ashes and so retards the drying. When, however, the mould becomes thoroughly warm throughout, there is little likelihood of any local condensation of moisture among the ashes in any part of the mould, and the speed of drying then depends upon the temperature to which the mould is brought in the stove.

It thus becomes a question of quantity, and, as an example, suppose that we have two brick structures, each measuring 1 cubic yard—one being solidly built of brick and loam throughout, and the other with loam joints on its outside courses only, the inside joints being made with ashes. Now, in the solidly built cube referred to, we shall have approximately double the loam used when compared with the second

cube, whose inside joints are all made with dry-ashes. It thus seems paradoxical for anyone to assert that in the drying of those two cubes the one containing the greatest percentage of water, from its wet loam joints throughout, should be the one to dry first, as against the one with its dry ash joints in the centre.

However, such is held to be the case by many good and successful men in the foundry, and it is quite in keeping with "cores feeding castings," "down pressure on the tops of cores when metal passes over them," etc., etc. But, to keep more to the question of materials for building loam-work, we are specially brought face to face with these two dry materials, viz., ashes and dry-sand, which are largely used by some when building integral parts of loam moulding; others do not recognise them at all. This we think a mistake, for reasons previously given. Each of these, *i.e.*, dry-sand and ashes, have their own particular function to perform in the foundry; but in this case it is for the purpose of venting and drying. Sand is most economical both in its use for building and that of emptying or taking a casting out of the pit, or from elsewhere, after it has been cast, because ashes, on the other hand, become contaminated with the *débris* of the mould, and so add considerably to the cost of lifting, after having cast, this class of castings—a point worthy of serious consideration. Therefore, as a result, ashes, in the author's opinion, should be used with discretion for building loam-work, unless venting in such work as we have described is a necessity; all the same, where venting and drying are equally necessitous use ashes as suggested. Again, as to which is best and without considering the economical side of the question at all, we unhesitatingly say dry-ashes, since they are practically unaltered in volume by the absorption of water. The proportion of shrinkage produceable by watering dry-sand to a moist consistency for moulding is a point in many ways worthy of the serious consideration of moulders. Dry-sand must always be used with discrimination. When dampness, or, worse still, water is encountered at the bottom of a hole that is being dug in the floor of a foundry, it is a mistake to get out the wet sand quickly and hurriedly replace it by dry-sand without having first stopped the entry of the water.

Serious losses often happen in this way, as many moulders know from experience, since the water ultimately soaks into the dry-sand causing it to contract, and, assuming a mould to be rammed up under such unfavourable conditions, the pressure of the metal at the bottom of the mould and at the time of casting tells its own tale by the casting showing ugly strains on the bottom when lifted, *i.e.*, if it has not finished itself previously by making for the roof at the time of pouring. This is the case with all earthy substances that are abnormally dry, and nothing but water or liquid of some kind will, in the first place, bring the greatest density. And, as a matter of fact, dry-sand in a foundry can never be reckoned as a fixed quantity, as absorption of moisture will in some degree cause it to shrink or contract.

On the other hand, absolutely dry-ashes is the friend of the moulder in damp pits and similar places. It is common practice, when dampness may be considered dangerous, to seek to form a channel by which it becomes located, and if possible connected to some way of escape. But if an ooze of water, such as is common to most foundries when working at abnormal depths in the floor, is likely to be a little troublesome, localise such as much as possible by forming a channel or hole. Get to know the volume of water collected in such space within a given time, and knowing the number of days or hours you have for ramming the job and casting it, you thus arrive at the size which the hole should be dug to contain the dry ashes, which absorbs the water practically, bulk for bulk, before it can get dangerously near the mould at all. Truly this material, dry-ashes, has many functions to perform in the foundry—first, in its capability of venting; second, in facilitating shrinkage; and third, in absorbing abnormal damp, the *foe* of the foundry, which has done so much mischief both to life and property wheresoever the art of founding is known.

Lastly, and most important of all, if a mould is known to be in a critical state from damp, make sure and dig a hole or trench, as the case may be, adjacent to the affected area of the mould, and at a depth sufficiently below the deepest part of it. Thereafter form a coke bed of sufficient section so as

to enable the water in the damp area of the mould to percolate into it ; and the water thus secured will flow into a temporary well or "sump" prepared in the process of ramming up the trench. This method of dealing with damp floors has, in the experience of the Author, saved what otherwise might have meant incalculable loss.

DIVISION III

MOULDING AND CASTING THE FINER METALS

STARTING A SMALL BRASS FOUNDRY

MACHINERY iron castings in general are accompanied by a greater or less percentage of brass castings, and these, according to location, are not always easily and cheaply got. Therefore convenience and economy is generally best secured by working a small brass foundry, or department, as an adjunct to an iron foundry situated in a country district. Besides, what suits in a general way the circumstances and situation referred to, will, without doubt, adapt itself in a quiet and unpretentious way to the jobbing work of a brass foundry in city life as well. If there be not much capital to account for, the chances are that such small brass foundries will give a better return for whatever money may be invested, with work at a fair remuneration, than many of the more up-to-date foundries. In short, there has always been, and will very likely continue to be, a place in mechanics for the jobbing brass founder. Hence, our purpose for the present is to deal more particularly with country districts where the local iron founder has to do a certain amount of brass casting, perhaps, in the smithy forge with an improvised fire or furnace, with the result that the opportunities for doing business to profit is neither practised nor developed.

On the lines suggested here, the outlay necessary to start a jobbing shop, or add a brass department to an already existing foundry, is not very great. All that is required is a suitable building of brick or iron, or a corner in the iron foundry, in which to put up a couple of good crucible furnaces, as illustrated in Figs. 126 and 127, a space for the accommodation of sand and fuel, of which only a few tons are needed, a few boxes, and a tub such as is illustrated in Fig. 128. Besides these

there is only the metal and a few other accessories to be considered before the equipment of a small brass foundry can be said to be, nominally, complete. As to the floor space necessary, a shop 14 ft. square will be sufficiently large as a start for the work common to local jobbings. It is desirable in arranging for this to select a spot contiguous to a chimney, as otherwise an improvised stack about 20 ft. high in brick or iron will be required. With regard to the plant mentioned above (the question of forced blast we do not entertain)

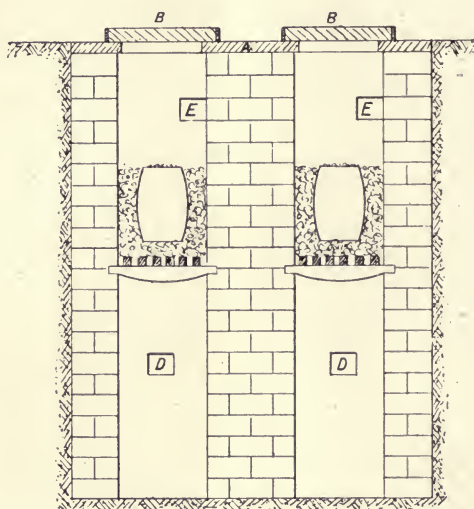

FIG. 126.

the sketches of the furnaces (Figs. 126 and 127) will be sufficient to afford all the information needed by a practical builder. It may be added, however, that the interior of the furnaces, and the flues immediately leading into the chimney should be of specially selected firebrick. As to the moulding-tub (Fig. 128), the sectional dimensions are given: the length will be determined, of course, by the space available. Coming to the moulding-boxes, their size will depend on the class of work intended to be done. However, three favourite sizes can be recommended for ordinary work, say, 10 ins. by 10 ins. by 4 ins.; 18 ins. by 12 ins. by 5 ins.; and 15 ins. by 11 ins. by 5 ins. The constructional details are described in "Starting a Small Iron Foundry" (p. 1). The foregoing is but a rough synopsis of location, building, and materials required for a small brass foundry.

Furnaces.—It is a truism to say that the furnaces for melting brass are in many cases of a very primitive type; some of

them are mere holes in the ground. The furnaces shown in the accompanying sketches, while not of the most up-to-date pattern, are, if built according to instructions, quite satisfactory, both as to time and economy of melting, under normal conditions of working. During recent years oil-fired furnaces have come into vogue, and some brass founders consider them suitable for smaller foundries. Before, however, they can be recommended unreservedly, the would-be brass founder

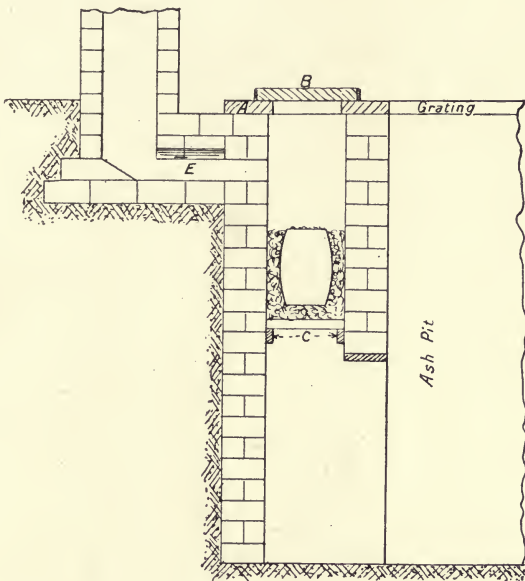

FIG. 127.

should consider well the relative facilities in his district for obtaining the fuels required for the competing systems, and if forced draught be imperative the relative cost of this and the chimney has got to be considered.

Figs. 126 and 127 represent the fires in section, and show the relative positions of the fire-bars, flues, and covers, with the crucibles in place. The dimensions given are 3 ft. 6 ins. deep from the cover to the fire-box, each furnace being 18 ins. square. Should there be reason to suppose that the fires may at any time be used for steel melting, 4 ins. or 5 ins. more space around

the crucible should be provided for in order to admit of gannister being rammed round the furnace, with a view of facilitating economical repairs. Personally, we favour the use of the gannister lining even in a furnace intended for brass. A good deal of time and money is wasted in pulling out fire-brick linings for repairs, when the process of ramming the "hole" with gannister 4 ins. thick would obviate much of the loss arising from frequent rebuilding. Round the top of the bricks a coping of cast iron *A* (Figs. 126 and 127), which should be 2 ins. thick, is imperative. This coping secures everything and provides a top to the furnace suitable for the reception of the covers *B* (Figs. 126 and 127), which ought to be level with the floor. The covers may

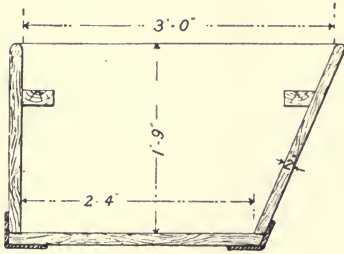

FIG. 128.

have cast-iron frames, with clay-tile centres and bow handles, such as are used for moulding-boxes; or they may be of 4-in. fire-clay tiles, bonded with wrought iron. The bearers of the fire-bars *C* should be built into the walls of the furnace about 3 ft. or 4 ft. above the level of the

furnace pit floor. The walls should be 18 ins. thick and a similar space between each furnace, the ashpit being formed below (see Figs. 126 and 127).

In laying out the cellar or ashpit, plenty of room should be allowed; there is nothing more annoying than to find, after the furnaces have been built, that there is not enough room in the ashpit for working. Fig. 126, *D*, shows the vent holes which connect with the general flue, not illustrated. The advantage of these is not commensurate with the expense involved, and they are on that account scarcely commendable. Again, at the same figure *E E* represent the other vents or flues which lead direct to the chimney at the top under the cover *B* (Figs. 126 and 127). These vent holes are usually regulated by means of a brick which retards or accelerates melting of the metal, so that the pot is ready for pouring at the proper time. The accessory equipment of a furnace consists of crucible tongs,

flat tongs, a poker, a crucible charger, a shovel, and a riddle. These are all too well known to admit of space being taken up with illustrations or figures of any kind; and here let it be said, that after pouring, a new pot should be put back into the furnace to cool down slowly with the fire, for thereby the life of the crucible will be prolonged.

Wastage in Melting.—The wastage in melting brass is always a matter calling for careful attention. It is necessary to avoid melting with too great heat in order to obviate “burning” the metal, which is a common cause of waste in brass foundries, and more especially is this the case where the reverberatory furnace is not in use. Some brass founders use ordinary “splint” or forge coal, which practice was common enough in the author’s early experience; but of recent year cheap cokes have come into the market, and nowadays it is more economical and in every way better to use these. It is not good practice to melt brass with good foundry coke, because its calorific value is higher than that required for the metal, and its use is needlessly sore on the crucible, to say nothing of the fact that there is always a possible chance of unnecessary loss of spelter due to too high a temperature. Brass is an alloy of copper and zinc (spelter) to which varying quantities of tin and lead are sometimes added. Copper melts at a temperature approaching $1,100^{\circ}$ C., which is more than double that of the melting points of either zinc, tin or lead. The temperature required in melting copper is, however, some two or three hundred degrees lower than that necessary in melting iron, and it is thus obvious that to use foundry coke for melting brass means employing an abnormally high temperature, and hence unnecessary waste.

In addition to wastage in melting, there is also wastage of metal in pouring. When the crucible is taken from the furnace, the skimming or cleaning of the metal should be done at the “skimmings box,” in which all refuse from the working of the pots is collected and afterwards dealt with. It is here that experience manifests itself in preparing the metal for pouring the moulds, as much spelter may be unduly wasted by unnecessary puddling and skimming before casting. Also after pouring, whatever sand may have been in touch with

a possible splutter should be fine riddled or sieved preparatory to hand washing, a process common in small jobbing shops. These points of economy mean money in proportion as they are practised, thus keeping the wastage of metal in a brass foundry producing jobbing castings, at the lowest possible point.

Moulding.—One of the greatest difficulties an iron moulder finds when he starts upon brass work, is connected with the gates, the position of which on the casting does not follow the rule for iron founding, either in location or volume. Brass oxidises more rapidly than iron, and when oxide is formed in the filling of a mould, it has a knack of finding its way into some portion of the casting where it is altogether out of place, and of causing a bad casting. Consequently, it follows that the mould must be poured rapidly, and in order to ensure this, the brass must be run about three times quicker than iron. By this we see that the proper position of the casting has much to do with the successful working of a brass foundry, and this is particularly the case with heavy brass. It does not require much imagination to see that quick pouring will necessitate good and quick venting, and to vent as one would do for iron, would involve risk of accident or mishap, because iron being poured so much slower than brass allows the vents to burn off their accumulating gases as fast as the mould is filled. The result of this is, that the gases in many cases are practically expelled before the mould is filled, whereas with brass it not infrequently happens that the mould is full before the vents are ignited. Practical moulders know that a “blow” and “sputter” may accompany the pouring of iron, and with a good deal of commotion too, and yet the casting may turn out all right because the gases get away, as a rule, while this commotion is going on, and thereafter the metal falls back quietly into the mould. But when the same kind of behaviour happens with brass, it is pretty safe to prophecy that the casting will not be a good one. On the other hand, brass, in spite of the fact that its surface when in the crucible is heavily laden with oxide, will penetrate a finer design and thinner section of metal than cast iron, which, under normal conditions of fluidity, seldom shows more than the oxide line clinging to the ladle previously to pouring.

Temperatures.—There is no doubt that temperature is a most important factor in the production of sound and homogeneous brass castings, as indeed it is in all processes in the different branches of founding. Although all metals in their behaviour during the fluid state have a strong relationship to one another, each has its own peculiar characteristic. The temperature at which brass may be poured with satisfactory results in various classes of work cannot be determined, except by that experience which is born of long practice. In this matter the general conditions must be considered, such as mixture of metal, condition of mould, and the volume of metal in section, etc., all of which are factors in determining at what temperature to pour.

Again, as to the constituents of brass, it should be pointed out that these have their own particular melting points, and it is at times difficult to decide whether the component parts of the alloys are strictly correct. The melting point of copper is 1083° C.; zinc is 420° C.; lead, which is not often used and alloys badly with other metals, is 327° C.; and lower than all, tin melts at 232° C. These differences are enough to create difficulties in themselves, and when we come to the specific gravities we find similar divergencies; copper is approximately given as 8.96, zinc 7.10, tin 7.29, and lead 11.45. Lead does not alloy with the copper and zinc in brass, but is present in the casting in the form of globules or streaks. This property of lead combined with its low melting point and high density causes it to have a great tendency to segregate, *i.e.*, to be unevenly distributed through the casting.

It is a matter for no surprise, therefore, that even the most experienced meet with disappointments when the relative parts of the various components are altered from well-known and established formulæ. Good gunmetal, in which there is a large percentage of copper, is salmon-red at the pouring point, and has a calm and placid surface; and from this standard working downwards the percentage of spelter increases, and with the higher percentages of spelter begins the erratic white flame on the surface of the metal. This increase of spelter brings us from the gunmetal, into the yellow metal alloys, when "stirring the metal up" to the moment of pouring becomes

imperative; and by so doing, the moulder does all that can reasonably be done to maintain in a well-mixed condition the metals which go to make up the brass. When using lead it is safer to melt it by itself before applying it to the fluid contents of any crucible, and keep stirring well in order that it may be thoroughly mixed with the alloy of which it is usually an insignificant but powerful constituent. The following are a few of many mixtures that could be given,¹ and although limited, these should accommodate themselves in a general way to the wants of a jobbing brass founder. Of course, brass moulders, as a rule, specialise in this department for themselves; but in connection with this it may be said in passing that, although it is economy to use as much as possible, it is never safe to go above 45 of spelter to 50 of copper.

Brass mixtures.	Copper.	Tin.	Spelter.	Lead.
Gun metal {	Soft	32	2	—
	Hard	16	2	—
	Admiralty	44	5	2
Yellow metal	35	1	15	—
Brazing solder	20	—	24	—
Common brass	28	—	14	1
Pot metal	16	—	—	5
Patent metal	32	2	—	—
Best gunmetal	16	2	—	—
Bell metal	16	4	—	—

BABBIT'S METAL.

Lead	48
Antimony	9

BABBIT'S METAL, No. 2.

Copper	10
Antimony	5
Tin	74

“*Draw.*”—Brass has a greater tendency to “draw” and form cavities than iron, and it is a common practice with some moulders to cover the risers and pouring head with sand immediately after the metal has been poured, ostensibly for the purpose of feeding the casting, but the advantage is more imaginary than real. A better result would, probably, be obtained by increasing the weight or altering the positions of the heads, or by using a carbonaceous

¹ The numbers given in the table are proportional parts, not percentages.

material instead of sand as a covering. All the same, sand must be applied in "covering-up" during the process of casting; comfort and other conveniences demand it so. The application of a feeding-rod after a brass mould is cast in general practice is not good, and where feeding is positively necessary to secure the densifying of any part of a brass casting, a crucible with suitable hot metal, and poured in on this particular spot, will in most cases do more good than is possible by the action of any feeding-rod. When applying the crucible for the purpose of feeding, give the metal a good drop so that it will cut its way into the casting; thereafter give what more it requires gently, and if the gate be right, it should feed itself automatically and give with perfect safety a sound and solid casting.

Position of Casting.—It is not given to all moulders alike to know how much "position of casting" has to do with the successful working or founding of metals. While vertical pouring may be the ideal of clean and solid castings in iron, the same practice, if applied to brass, in many cases would have quite an opposite effect, as the following will show:—

More than twenty years ago a certain brass casting was by special request ordered to be cast on end. A rough idea of the casting (shown in two positions in Figs. 129 and 130) is given by stating that its principal dimensions were 4 ft.

by 2 ft., with two or three side attachments, and six or seven cores distributed about the body of the casting (not shown in the figures referred to), and that its weight was about 1,200 lbs.

Doubts were at once expressed when discussing the "vertical position" in which this job was ordered to be cast, but ultimately it was agreed to cast it on the "declivity position." All went well both with moulding and pouring the metal into the mould, but when the casting was turned out next morning, its top end was one of the most unsightly forms of metal supposed to be in the shape of a casting imaginable.

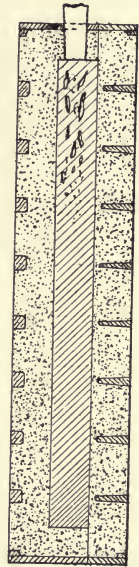

FIG. 129.

Evidently, although it was a dry-sand mould, the flow of the metal to the bottom and its return to the top end during the process of pouring was more than the alloy in question was capable of doing rightly, as the accumulation of oxide at the top end made this part of the casting exceedingly wavy and rough, and was more than enough to condemn it. Besides this wavy and oxide-laden surface, this "waster" was aggravated by large and deep "drawn" holes; and although a lost casting, it gave a splendid object lesson on the effects of "draw." The result of this failure in the "declivity position,"

was an imperative order for one to be moulded without delay and cast "on end" or "vertically," the position originally discussed. In this position the job was gated and dropped from the top, and fed well; the pouring gates were two in number and made about $2\frac{1}{2}$ ins. square, so that the best chance possible for feeding would be got (see Fig. 129.) Briefly, all went satisfactorily up to the point of feeding, but when the moulder applied his

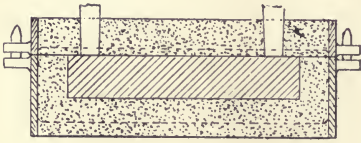

FIG. 130.

"rod" for this purpose, he had not gone many strokes when it was "frozen" or held fast in the gate, and so the operation of feeding the casting was cut short for the time being. When the casting was turned out, it looked fairly well, as it was smooth skinned from top to bottom; but, beneath the surface of the top end shrinkholes were formed by "draw," and in a more intense form than previously, which at once convinced all interested that a "scrap" had been cast instead of a casting.

Again, another one was tried with every detail of moulding and casting practically the same, the only difference being that when the metal came through into the "riser" a hot crucible with a fair supply of metal was in waiting to "lubricate" the feeders, and "pour through" to give the casting every possible chance of being solid; with this a considerable improvement was effected, but not enough to save the casting; which was again lost from the same cause as before, namely, draw shrinkholes in its top end.

At this point we count three attempts and as many failures, so that what followed may be better imagined than explained ; suffice it is to say that the moulder on the job, who had given the habits of metal some consideration, suggested to cast it on its "flat." This was at first demurred to, as the casting was to be equally polished all over, and it was feared that it would have a dirty top side from this position. However, the moulder being prepared to explain himself in detail, and confident of success in casting it "dead flat" or horizontal, it was ultimately agreed to have a trial, and the first one cast in this new position proved him to be correct ; needless to say it came out perfectly clean and solid, the top side of the casting being practically as good in this respect as the bottom.

Now, as there was nothing unusual in the moulding of this job, time need not be unduly wasted further than to state, as before, that it was a dry-sand mould, perfectly moulded, properly gated, and cast with an alloy of good-conditioned metal. Consequently it became a question of position of casting, for the better securing of uniform compression, a thing it had not received in either of the positions of casting previously. Such was the standpoint from which the moulder viewed this difficulty, and the after results showed the wisdom of his convictions.

In turning to Figs. 129 and 130 there is seen in the two sections the contrast between the two different positions suggested. The first position which was "down-hill" or declivity, and which cast with such indifferent results, is passed by without further comment. Fig. 129 is intended to represent in section the defects which condemned the casting when cast in the position illustrated. Alongside of this there is Fig. 130 representing absolute uniformity and homogeneity of the metal ; the former, of course, is a scrap, and the latter a casting.

The moulder, in suggesting that this job should be cast in the flat position, had in view the fact that most metals shrink in passing through the process of solidification, and that the damage that may be done by this is minimised or altogether prevented by reducing the depth of the mould as much as possible. The two figures given are supposed to represent

two moulds containing solidified castings, the one being 4 ft. deep and the other 4 ins. deep, irrespective of risers, etc., so that by casting this job on the flat (Fig. 130) there were 4 ins. instead of the previous 48 ins. (Fig. 129) of "sink" and "shrink" (the term "sink" being often used instead of "draw"). The unsoundness due to the effects of shrinkage was thus reduced to a minimum, and the adoption of the flat position put an end to all the trouble previously experienced. Position, however, although of such importance in the case of all brass or gunmetal castings, is not the only factor on which success depends, another being the conditions of cooling. From a further examination of Figs. 129 and 130 it will be noticed that only in the latter instance is uniformity of cooling possible. With this casting poured in the flat position everything is uniform, even to the distribution of gates (not shown) which were six in number, each $1\frac{3}{4}$ ins. in diameter, and were placed across the box containing the job. In casting, a double basin pouring head was made of suitable dimensions, and with a ladle at each basin, and pouring instantly together, the cast was completed in a comparatively few seconds. The ebb from the fluid metal in the basins flowing splendidly back into the mould made a complete automatic feed of all gates, which resulted in a clean and solid casting as before mentioned. Four of these castings were made consecutively and on the lines suggested without a hitch. Therefore, what applies to the casting as illustrated at Fig. 129, applies also in a greater or less degree to all vertical projections and sections of such castings as the hubs or bosses of propellers, and such like; and for safety and to secure absolute soundness on solidification a margin of mould is necessary to whatever the finished length a casting may be, and by feeding here with hot metal after the mould is cast, we may be perfectly safe in saying, that when this margin or sinking-head, which should be the last part to set, is provided the rest should be a good solid casting.

Cooling the Castings.—Having gone further in the direction of heavy work than was intended, we return to the common practice of brass moulders in light work, who lift their castings while hot and plunge them into a water trough.

Briefly this practice is not commendable for castings that are liable to irregular shrinkage, as such treatment may spring the class of castings referred to, or at least shorten their life. But where plain section articles are being made it is perfectly safe to plunge comparatively hot castings into a water trough, and in this way improve, in many cases, the metal, and at the same time facilitate fettling.

BRONZES

Aluminium Bronze (copper, 90 ; aluminium, 10).—This metal has a greater shrinkage than gunmetal, and is generally regarded as the discovery of Dr. Percy. When working this metal everything possible to expedite shrinkage must be attended to.

Phosphor Bronze.—In making phosphor bronze, it must be pointed out that phosphorus is so powerful a constituent, and the percentage used for this purpose is so small that phosphor copper and phosphor tin have of necessity been compounded, thus forming two separate alloys for the safer manipulation of phosphor bronze castings. Phosphor copper usually contains 15 per cent. phosphorus, and phosphor tin contains only 5 per cent. of this metalloid : the use of the latter alloy is generally most commendable. In making phosphor bronze alloys by the addition of either phosphor copper or phosphor tin we are fairly safe in keeping within 10 per cent. of either. Or again, the full quantity decided upon may be proportioned according to immediate demands and other circumstances combined.

However, a good phosphor bronze can be got from copper and tin, and, say, traces of phosphorus. The hard type of phosphor bronze is used for casting pinions, small spur, and bevel wheels, brass bearings, and other castings, requiring extraordinary anti-frictional metal. The following are the specified requirements of the Admiralty for phosphor bronze castings :—

"No. 1."		"No. 2."	
Copper	90 per cent.	Copper	83 per cent.
Phosphor Tin	10 "	Phosphor Copper	7 "
		Tin	10 "

Manganese Bronze.—As is known, this alloy contains a large amount of spelter, and is to all intents and purposes a very strong yellow metal; and in making up this metal, manganese in the form of “cupro-manganese,” or “ferro-manganese” may be used. The former contains 20 per cent. metallic manganese, and the latter contains approximately 80 per cent. manganese. In the working of this metal, as with all others containing a high percentage of spelter, an allowance of 3 lbs. or 4 lbs. per hundred should be added for the wastage common to the melting of zinc.

For this and all other bronzes moulded and cast, dry-sand moulds are at all times the best; but where such is not conveniently got, then dry the green-sand moulds, and the results of casting will more than compensate for all the trouble taken in this matter.

The “plug-gate” system of casting is much admired by some for this sort of metal, but to others the gain is not commensurate with the trouble involved. Given good metal, skimmed well and cast at the proper temperature, which must be as dull as is compatible with the safe running of the mould, gating from the bottom will bring results more satisfactory in the securing of a clean, sound, and solid casting than is possible to any other method of casting. But no matter whether the gate or gates be controlled by plug or plugs, oxidation inevitably becomes increased when run from the top by the process of churning going on inside of the mould at the time of pouring the metal. All metals coarse or fine are cleaner and better cast into moulds, and produce better castings, when run from the bottom—a truth not acceptable to many, but which is the rock-bottom of experience. Herewith is appended a mixture suitable for propeller blades, and which has considerable ductility for working cold, and resists corrosion when exposed to water:—

Copper	54 per cent.
Zinc	43 „
Manganese	2 „
Aluminium	1 „

CASTING SPECULUMS

The writer's experience in this particular class of castings is somewhat unique, inasmuch as it was his good fortune to cast speculums from 9 ins. to 14 ins. diameter for a distinguished member of the Royal Astronomical Society. The difficulties of securing an absolute polish or lustre on the face of those castings gave one a training in the manipulating of metals in the art of founding far above the average of what is common to the work of the ordinary brass founder, and this is specially so as it relates to the habits of metal while passing from the fluid condition to absolute shrinkage. As has already been noted, those castings have to take on not only a bright finish, but a dense and lustrous polish far in excess of any other metal the writer had ever before seen or heard of. Thus it came about that one speck, no matter however small, or even one pinhole on the polished face of those castings was in either case enough to condemn them, and as a matter of fact the percentage of good castings from the lot made was but small indeed.

The Alloy.—Speculum metal is a very uncommon alloy in brass foundry practice, although it is common knowledge to say that it is made up of copper, tin, antimony, arsenic, and some might add to this lead and silver also. However, it is said that "Ross's alloy" contained copper 68·21 per cent., tin 31·79 per cent.; be this as it may, we give it for what it is worth.

All speculum metals are very brittle, white in colour, and when good, are said to make a much superior mirror to that of glass, although the latter has to a great extent displaced the "metal speculum," doubtless due to the great difficulty of getting the spotless lustre referred to.

Brittleness signifies excessive hardness, and as a result the annealing of these castings becomes imperative. Therefore these castings, after being poured and solidified, are removed at the proper time to a small improvised oven prepared for them, and after being annealed the stipulated time, are allowed to cool down to atmospheric temperature, and of course are then afterwards taken out from their packing, preparatory to the polishing process referred to.

“*Draw.*”—One of the most striking peculiarities of speculum metal is to be found in its great tendency to “draw.” With these castings, heavy direct-acting gates were located on the top side, sometimes two and sometimes three in number, but even with such supplies for compressing purposes, it was no unusual affair to see them lost by their gates having “drawn” right down through their centres from top to bottom, and in some cases well through towards the face of the casting as seen at Fig. 131. This phenomenon led to experimenting in compression, and in this matter things remained much the same as before until “open-sand” casting was resorted to, rather a strange device for the better compression of metals. But no matter however strange it may appear, the “open-sand” casting proved superior to those that had been flaked and fed automatically from the heavy arrangement of gates previously mentioned.

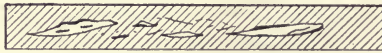

FIG. 131.

As is well known, the backs of these castings are not very particular, otherwise this somewhat crude method of moulding and

casting could never have been entertained at all. “Open-sand” was the method of this experienced gentleman’s amateur days of speculum founding, and to this, after many years, he returned with improved practice.

Fig. 132 is approximately the view in section when this “open-sand” casting, as represented here, was broken up. Nevertheless, its polished face was an improvement on some previously flaked. But at this juncture the idea of cooling from the bottom upwards had manifested itself, and as a result a second one was tried, but immediately after it was poured, this casting was judiciously covered with a carbonaceous compound; with the result that the success, as anticipated, had now become matter of fact, and from this onward open sand became a fixed principle of casting the speculums in question—a point of special note to the amateur telescope maker.

In Figs. 131 and 132, accompanying this article, we have a very valuable and unusual object lesson in the solidification of metals, and for this purpose specifically we give actual

experience in this matter as it occurred to the writer in practice some years ago.

Treatment of Castings.—Briefly put, Fig. 131 on being cast was covered up in the usual way by sifting a little sand over the top of it, which resulted in its exposed surface being rapidly cooled, while underneath it was comparatively fluid; and as this part had still to solidify, the roof remained, so to speak, a fixed and immovable quantity, while the fluid or plastic metal continued to shrink and sink towards the bottom, thus creating the shrinkholes illustrated in Fig. 131, and rendering it a scrap.

In Fig. 132 the method of treating the job was in every respect the same with but one exception, namely, in that it was covered up with the carbonaceous material previously mentioned. The result will be obvious; the judicious covering up with carbon retarded the setting of the top metal, and being comparatively a thin casting, it would be difficult to



FIG. 132.

say which of the sides solidified first. These castings varied from $1\frac{1}{4}$ ins. to $1\frac{3}{4}$ ins. rough metal, and the concave form, as illustrated at Fig. 132, conveys at once to the practical eye the effect this carbonaceous covering had in densifying this metal by cooling, as far as it was practically possible, from the bottom side upwards.

Compression.—It is an open question as to whether fluid metals passing through the process of solidification while cooling are mechanically compressible or not. Within certain limits it may be possible, but no artificial application in the compressing of fluid metals, however ingeniously and powerfully applied (in the author's opinion) will ever densify the top end, of, say, an ingot casting or any other body of metal, coarse or fine, equally dense and homogeneous with its bottom end.

There is a means of densifying more effectively than by mechanical compression, and that is to cool from the bottom upwards. Although the process is slow, the object aimed at can be secured within certain limits. But the economic value of the process creates matter for doubt and discussion, and it

being an inversion of nature, its adoption is not likely to be a practical possibility within easy reach. All the same, the method illustrated by Fig. 132 gave absolute density, truly a phenomenon in "open-sand" casting when compared with flasked work.

Melting and Pouring.—But to return more particularly to the subject of speculum casting, pouring with abnormal basins and increased vertical height, ostensibly for the purpose of better solidification, and its consequent improved density, is to no purpose if the metal and method of treating it be wrong, and Fig. 132, as illustrating the after-treatment in casting those speculums, is more than ample proof of the above assertion.

In preparing the furnace and pot for melting the metal, needless to say, all things pertaining thereto must be in good condition—a suitable fire and pot previously prepared by annealing and cleaning, so that the best chance possible of getting the metal pure and good will be secured. No "coaling up," if possible, during the process of melting should take place; likewise the pot should have a good mouth for securing a smart and clean pour with the metal.

In charging, care should be taken to avoid overloading the crucible, as the metal is liable to become contaminated with fuel and dirt. It is better to charge a portion first, and when this has "sweated" down add a fresh portion of the charge.

Care must be taken while the melting is proceeding not to hurry it in any way, otherwise it may be detrimental to the purity and homogeneity of the metal. On the crucible being taken from the furnace, skim and flux by the assistance of rosin. This may be repeated more than once if thought necessary, but with things normal the second fluxing and cleaning should be quite enough for what is wanted, namely, the cleanest of metal possible.

Before pouring, clean the mouth of the crucible by brushing, and dust a little ground rosin over the face of the mould through a common blacking bag. This will tend very much to keep the oxide common to this alloy from sticking to the face of the mould while pouring the metal, and in that way maintain fluidity of metal otherwise impossible.

Thus we summarise speculum casting :—(1) The alloy, (2) treatment of castings and results, (3) compression, (4) melting and pouring, and (5) moulding. Practically there is but little to say on moulding, that is to say, if it be an open-sand mould that is to be considered, and if it be flasked perhaps enough has already been referred to. Of course, nothing short of a good “dry-sand” mould will do. In making the mould, and at the drawing of the pattern, there must be no attempt at finishing the face, and if the mould be not correct, break it up entirely and make a new one. It should be made of rock sand or London sand, or any other similar sand that will “bake” when exposed to heat. A spray of beer blown over the face will much improve its surface when judiciously applied, and will give it a double chance against any particles of sand rising from its surface during the operation of pouring. And lastly, when taken from the stove to cast, it should have a good heat about it, which in turn will give the metal all the better chance against oxidisation. This, together with the dust of rosin as suggested, completes all that is humanly possible, so far as the writer knows, in moulding and casting speculums and for the better securing of a sound and spotless finished casting.

ALUMINIUM FOUNDRY

The metal used for aluminium castings has its own peculiarities, both as regards moulding and casting ; but while this is so, a practical green-sand moulder of cast iron can, with a few hints, adapt himself in a comparatively short time to bench or tub moulding by which a high percentage of the castings from this metal are produced. And of all metals founded aluminium can scarcely be said to be the most difficult to cast, and we are safe in stating that none is less liable to scabbing ; and in the matter of lifting pressure of cores, if once these are put into their proper place, and the “lift” be normal, we have no need to fear that they will be moved by pressure of any kind. These two points bring us face to face with two of the most difficult problems in foundry practice, namely, pressure and scabbing. Now, with regard to the first, we notice that what must be secured ordinarily in

moulds by chaplets, nails, or some other device, in the case of iron, steel, brass, or other metals specifically heavier, would be perfectly safe without any such assistance in a mould cast with aluminium. The reason for this is due to the relatively low specific gravity of the metal, which is given at about 2.60. Bulk for bulk sand and aluminium are approximately of the same weight, and since a solid immersed in a liquid is buoyed up by a force equal to the weight of the liquid displaced, there will be no lifting pressure when the weight of the solid is the same as or greater than that of the liquid displaced. Hence it is that cores in many cases do not "lift" when enshrouded with fluid aluminium in a mould as is the case with other metals of greater specific gravity.

Our next point is the problem of "scabbing," and as scabbing is doubtless due in a greater or less degree to intensity of heat, which leads to the generation of gases, and their ignition, it naturally follows that the more intense the heat of any metal with which a mould is cast, the greater will be the volume of gas formed, and the more the gas-producing substances, which are contained in all sands used for cores and moulds, will manifest themselves at the time of pouring a mould. But whether scabbing be due entirely to evolution of gases and bad venting, or these and heat combined, the comparatively low temperature and small amount of gas generated in the case of aluminium, as compared with other metals, may explain why aluminium and the other white metals are comparatively, if not altogether, free from scabbing when cast under ordinary conditions of moulding.

The foregoing opens up a wide field as to the cause and effect of the scabbing of metals, and the behaviour of fluid metals in moulds; but we can only pause to note the relation between tendency to scabbing and the melting points of some of the metals commonly used in the foundry. (1) Steel has a melting point of about 1,450° C. (2) Cast iron melts at about 1,200° C. (3) Gunmetal as an alloy might be put down as approximately 1,000° C., and aluminium, say, 650° C. From this it will be seen that the tendency of scabbing increases in proportion as the melting points of these metals increase in temperature. Thus it is that steel moulding

requires so much "sprigging," and in many cases it is simply a nailing down of the whole surface of a mould to keep it from scabbing; this being due to the intense heat of the fluid metal with which it is cast. Cast iron comes next, brass follows it, and aluminium with a melting point less than the half that of steel, has, with all conditions of moulding being equal, comparatively no danger of scabbing at all. Therefore we may safely conclude that heat is a positive factor in scabbing.

In this connection the difference in the effects observable when these metals are cast into moulds is very striking. For example, in the case of iron and steel, a large volume of combustible gas which burns brightly is generated, and in many cases continues for long after pouring to send out a bright flame like a torch from the particular vent of mould or core as the case may be.

But, on the other hand, pour the same mould with brass, and the contrast becomes very marked indeed. I have never in all my experience, seen brass poured into a mould whose heat afterwards was sufficiently great to ignite and burn the straw from the core-bar used in making the loam core employed in the production of such a casting. And as to aluminium, whose melting point has already been referred to as some 300° or 400° C. below that of gunmetal, the heat is obviously insufficient to ignite to any great extent the combustible materials in the mould or cores. Hence, as a matter of fact, with ordinary care aluminium casting is performed very quietly; and but for a little steam which may rise from the sand of which the "basins" are made for the respective moulds that are cast, little or no outside indication of a mould being cast (with things normal) is usually visible.

Sand.—A good deal has been written about the sand used for aluminium moulds. Some authorities declare that it is imperative that all sands for facing should pass through a hair sieve. This seems a somewhat novel and unpractical suggestion, and we have no experience of such niceties—indeed, such fine sifting is not to be commended. A mould or core which is deprived of the grainy texture in the surface against which the metal has to strike is likely to result in cracked castings.

Moreover, the moulder must avoid the density of surface on mould or core such as is produced by blackwashing. The treatment suitable for green-sand work can with perfect safety be practised with aluminium moulding, and sand which has been sieved as fine as for green-sand work will, as a rule, do all that is required. In drawing a pattern from the sand use as little swab-water as possible, and the same applies to the mould; thereafter a slight dust from a tarra-flake or French-chalk dusting bag should complete all that is required in finishing the mould made on tub, bench, or machine.

Gating.—The popular idea favours large gates and quick running, but as a rule and for general practice it is a mistake to adopt this method. The better way is to gate as for iron. By adopting this rule when running aluminium moulds we are on fairly safe lines, though the moulder must not allow himself to be tied by a hard-and-fast rule. Take the case of running from the highest part of the mould: no harm in many cases would happen with aluminium though it would not answer with iron. For example, a name-plate, whether large or small, might be “drop-gated” anywhere and run from the top amongst the letters without fear of damage to the casting. Care must be taken against filling the mould too quickly, otherwise the mould may not be poured at all, because aluminium, which oxidises rapidly and is of low specific gravity, is said to lack the power to expel the air from the mould quickly enough to allow the metal to fill all the space it should do. Consequently, the rate of filling the mould means much in pouring aluminium.

Risers.—These are not advisable in small and light work, but a “blow-off” from a pricker or vent wire at the end opposite to the “gating” will do no harm, and may often help matters. Experience, however, has proved that even these can be dispensed with when the sand, metal, and workmanship are all really good and suitable. Where, however, a heavy part exists on the casting, a riser large enough to admit of unaided or automatic feeding may be applied with advantage. These remarks principally apply to castings of medium weight in this metal.

Melting.—In melting aluminium metal, see to it that the

fire is in good condition before setting the crucible, which should be placed on the fire with enough fuel round it to bring off the heat without the necessity of "coaling-up" in the middle or anywhere else during the process of melting the respective charges in the crucible. There is no difficulty experienced in this, as a "heat" with a 50-lb. or 60-lb. crucible ought not to take more than 40 or 45 minutes; smaller or larger quantities will vary in time proportionately.

In charging the crucible care must be taken to see that none of the metal projects above the crucible, and the charge should be of uniform size, at least in so far as this is possible. This obviates the risk of exposing the metal to the flame, and minimises oxidisation. In the process of melting, a strict look-out must be kept on the metal, and when it reaches the liquid state the furnace cover may be lifted to allow the heat to rise gradually to the requisite point, which is somewhere about 650° C. When this stage is reached, scrap or small pieces of metal may be added to bring up the quantity, if need be. When the pot is drawn from the fire it ought not to be hotter than the metal; pouring from a superheated crucible means that the excess of heat is absorbed in the metal, a condition of things which does not favour the casting.

It is a serious mistake to allow the metal to get hotter than is required for pouring the mould; of course, it is true that any temperature can be lowered by adding suitable scrap and waiting, but on the other hand, mischief is undoubtedly done by over-heating. Few things can be more mischievous than oxide in any metal, and with no metals does this fact impress itself more than with white metal castings.

Again, the oxidised metal and scum which collects on the surface of the crucible should not be disturbed. All that is necessary is to push it back with the skimmer before pouring, the residue remaining to keep subsequent charges from oxidising. Of course, sooner or later this scum collects in such quantities that its removal ultimately becomes imperative.

Aluminium unalloyed is but rare, and the evil of this is that some work with it as if it were all of the same composition, and believe that what is right for one metal will be

equally good for all. This is not the case, and those who have to make aluminium castings should at all times know the true value of the alloy that they are making castings from. But apart from this, assuming our metal has been graded, the next question is, How are we to melt it? With some an iron ladle is deemed quite suitable, but we have never found this so in practice, and while this may be a convenience where patterns are being cast, such a practice cannot be resorted to where the castings are for customers. All metal for marketable castings should be melted in a crucible of a quality suitable for brass, and must be aided in this by forced draught or a chimney; in other words, no place is so suitable for melting aluminium as the furnace of an ordinary brass foundry.

Temperature.—On the question of temperature we have little advice to give, for until some inventor gives us a foundry pyrometer really suitable for testing metals outside the furnace, and that can be read as easily as the practical eye “reads heat” by the colour of the feeding-rod after it has been put into the ladle or crucible for this purpose, we are not likely to obtain any definite data for the guidance of foundry men. All the same, if a founder is well grounded in the belief that yellow brass cannot be cast too hot, phosphor bronze cannot be cast too dull, gunmetal should be cast at a nice heat, and anti-friction metal should never be allowed to come to a red heat, he has within certain limits a basis for calculating the temperature at which to cast any alloy, and of course this specially refers to aluminium.

It may be said with safety that all are agreed that the secret of success in aluminium casting lies in the melting; consequently we must take care not to overheat or burn it. If once it is heated abnormally, the difficulty of bringing it back to the proper normal condition is great indeed.

The chances are that metal mistreated in the way indicated will be badly speckled with pinholes, or gas-holes, as some term them, although others ascribe this trouble to the use of the graphite crucible which melts the metal. The pinholes are a real nuisance, but neither explanation is free from doubt, for the trouble occurs with white metals, brass and other

alloys. However, there is a general concensus of opinion that pinholes are the result of excessive heat while the metal is in the furnace. This is due to the oxide which is formed, and which diffuses itself to a greater or less extent throughout the contents of the crucible, thus causing the "dirt" which makes the pinholes. Aluminium may carry a very large percentage of zinc, which has only a melting point of 425° C., and has a specific gravity of about 7, which is roughly three times that of aluminium. Zinc has the disadvantage of being rarely pure, usually containing lead, tin, iron, and arsenic, so that impurity of aluminium castings may at times be traceable to the zinc used as alloy, and especially will this be so if it carry a high percentage. However, it follows that our first concern must be to melt aluminium cautiously, so that that condition of fluidity best suited for pouring may be intercepted at the right moment. After all, nothing but experience will teach a man how to mould, melt metals, and cast at the right temperature, three of the principal factors in the production of all metals that are cast, whether they be white or yellow.

ALUMINIUM CASTINGS AND ALLOYS

What are known as aluminium castings are every day coming more and more into use for industrial purposes, and yet this metal, generally speaking, is as much an alloy as brass is an alloy of copper. In point of fact, aluminium is mixed with zinc, the latter at times amounting to as much as 30 per cent. of the whole, so that it is hardly correct to speak of all wares made from such a material as aluminium castings. We might as well speak of all brass for pouring castings as being copper castings, since copper, as a rule, is the predominant constituent of brass alloys for machinery castings.

The increased and extended uses of this metal during the last few years, both as an alloy with other metals and the product aluminium castings, have now established aluminium founding as a branch of the foundry industries of Great Britain. Truly a somewhat marvellous expansion with a metal which but a comparatively few years ago was very

much confined to the experiments of the chemist in the laboratory! Its field is unlimited because of its affinity for other metals, low specific gravity, anti-frictional qualities, and silvery-white colour, for which it is much admired in the many ornamental and useful fittings to which it has of late been applied.

Aluminium compares favourably in price with the other finer metals for machinery castings, and although it should continue to keep twice the price of copper (the chief factor of brass) which is its greatest opponent, it will under such prices work out considerably cheaper than any brass alloy suitable for the castings referred to. Bulk for bulk the weights of aluminium and copper are approximately as three is to one; consequently, for one casting in copper three such castings can be produced from the same weight of aluminium.

Raw aluminium, although fairly near the possible 100 of purity, would not be suitable for castings, and, as a matter of fact, there is no such thing as pure aluminium castings. Hence, in a commercial sense it is difficult for the uninitiated to decide the true value of graded aluminium metals from an *£ s. d.* point of view. Therefore, its pecuniary value from the raw metal price will be reduced in proportion to whatever zinc it contains; and when we consider the market value of these metals, which is as seven is to one, no further explanation is necessary here. But apart from this, the addition of zinc, tin, nickel, or even copper, is common practice, and necessarily affects the quality of the resulting "aluminium castings."

The compounding of aluminium alloys, which can be applied to many industrial processes, has become an important business, and will doubtless go on increasingly as the supplies of metal meet the demands of an ever-increasing output of "aluminium castings." And if the prophecies of some eminent metallurgists of the present day happen to be fulfilled, we may emerge from the iron and steel age of to-day into that of aluminium before the present century is closed. We have it on high authority "that there is certainly more aluminium in the clay of the earth than there is of iron-stone

in its veins," so that, following the exhaustion of iron, if ever that should come, there is the hope of a practically inexhaustible supply of what amongst metals was but a few years ago unknown in the castings trade.

While there is undoubtedly a large and immediate demand for this metal in the "aluminium casting" trade, its usefulness as a reducing agent in the melting of metals for all kinds of castings is recognised also by those engaged in the industrial manufacture of forge and foundry products, but it is not right to speak of it in this connection as a flux in the sense in which that term is used by metallurgists. A flux is a substance added to a metal or metalliferous compound with a view of purging or eliminating foreign matter into a fusible slag, thus purifying the metal acted upon.

Reducing agents have the power of deoxidising, desulphurising, and assimilating compounds. The judicious employment of a reducing agent will often get rid of the "boil," and with a minimum of heat in pouring give great fluidity and secure the advantage of the lowest shrinkage possible after pouring.

Aluminium ranks third in malleability and sixth in ductility of metals, and is capable of carrying a high percentage of zinc without showing the shrinkage associated with lead. Zinc as a metal for alloying with aluminium is better than tin, the use of the latter increasing the tendency of the castings to crack. In melting the usual alloy the aluminium should be fused before the zinc is introduced. A good alloy for electrical castings can be melted with 47 parts of aluminium to 3 of copper. Nickel aluminium is an alloy of nickel and copper, together with aluminium.

Perhaps the greatest difficulty in making alloys with this metal is connected with aluminium yellow brass, which some say will not stand heavy hydraulic pressure; but this complaint is doubtless more due to disproportionate metal, undue temperature, and shrinkage. Yellow aluminium brass gives a high percentage of waste, which may run from 5 per cent. to 10 per cent., because of the high percentage of zinc it contains.

Aluminium bronze is a metal difficult to machine, on account of its high tensile strength. Its constituent parts are 1 of aluminium to 9 of copper, and it possesses high qualities as an anti-friction metal. When used in the casting of valves for fittings likely to be subjected to water pressure there is sometimes trouble from sweating. This porosity may make itself apparent with the pressure as low as 200 lbs. per square inch. It is only fair to say that alloys other than those in which aluminium enters exhibit under pressure this phenomenon, which can be detected easily without recourse to the test of the hydraulic ram. It is simply necessary in testing to fill the valve, fitting or pipe, as the case may be, with water under atmospheric pressure, and if there be the least defect due to want of homogeneity or to shrinkage strains in any casting thus treated, such will reveal itself by sweating or dampness on the outside visible to the naked eye.

“MALLEABLE CAST.”

Many founders engaged in brass and iron founding, and especially those employed at small work, must, at some time or other, have wished to add “malleable cast” to their business.

Where capital is scarcer than understanding, experiments can, and should, be made in a primitive way before entering the market for commercial competition, and the knowledge thus acquired, even if it is never used in the “malleable casting” trade, is well worth the comparatively little expense involved.

A small cupola such as is common in many large foundries, and in small country shops doing, say, 30-cwt. to 40-cwt. heats, lends itself admirably to experimental work, and if the castings sampled can be annealed elsewhere, we are thus practising on lines of the greatest safety and economy. Such has been the procedure followed by others in “malleable” founding in its initial stage, and from this anyone will know how far he may venture. The uninitiated must understand that the process presents more difficulties than either brass or iron, as will be shown further on.

Assuming, then, that one is starting for the first time this branch of founding, herein is described shortly in detail what is wanted and what steps have to be taken. This class of work generally consists of parts of agricultural machinery, harness-room fittings, and small parts for machines which had formerly to be forged from wrought iron. Since the introduction of the "malleable cast" process the malleable forged parts referred to have been in many cases supplanted by "malleable castings," with economies alike to engineer and buyer.

Briefly put, the work is divided into three parts—moulding, mixing of the metal, and the annealing of the castings. With regard to the moulding, a good green-sand moulder for general small work in cast iron will readily adapt himself to "malleable cast"; everything, such as ramming and moulding for cast iron in a general way is the same, except, perhaps, the "gating." With articles where square corners occur, good filleting must be arranged, with a due regard to the proportions of the metal; unless this is done, such parts will crack and spring. All gates should be made larger than those used for grey iron.

Metal.—As to the metal used in the manufacture of malleable cast, "charcoal iron" gives the best results, but as a rule it is too expensive to use. There is, however, a special make of iron, called "Malleable-Bessemer" or "Malleable-coke" iron, which is the principal brand used. Ordinary No. 1 hematite, mixed with malleable and unannealed scrap and with a percentage of white iron, forms a mixture which may with safety be used for most ordinary small castings. Care must be taken not to add too much malleable, otherwise the carbon becomes reduced to a point where fluidity is sacrificed, thus rendering the metal useless for castings of ordinary design.

Some foundries melt their metal with the reverberatory furnace and the open hearth; others use the cupola, which is asserted to be the cheapest process. But iron melted in the cupola is not the best, and test bars made from this iron are, as a rule, a few thousand pounds less per square inch than those produced from "furnace iron."

Where only a small trade is done the "crucible method" of melting is most satisfactory. By this process we get uniformity of heat, and the purest of iron possible; besides avoiding the expense due to extraordinary wastage of the cupola lining by the excessive heat necessary for melting a malleable-cast mixture in the cupola. Those who desire to add this branch of founding to their existing iron trade business would undoubtedly find the "crucible process" the most convenient way to produce the cheapest and best malleable castings. The chimney necessary for the annealing furnace may be utilised for the crucible furnaces also.

Annealing.—The process of annealing presents many problems to the would-be "malleable cast" founder. It is the point at which most failures occur, chiefly owing to the use of improvised annealing ovens. Unless the foundry master is prepared to go to the expense of a suitable oven, he had better leave the notion of malleable-cast jobbing severely alone.

If, however, a chimney is at command the expense is not so very great; all that is to be done is to build the oven and connect by a suitable flue. The best way to set about this part of the work is to engage a bricklayer with experience in building furnaces, and although such a man may cost more at the outset, in the end his services will prove cheapest.

This process involves the heating of castings to a high temperature. The castings are placed in cast-iron boxes and packed with iron ore or "mill cinder," care being taken to place them so that no two articles shall touch one another, and thus obviate fusion when the maximum of heat is attained in the oven. The time for annealing is indefinite, and can only be determined by the work to be done, that is to say, by the thickness of the castings packed in the boxes. Of course, all ovens have peculiarities of their own, and the castings requiring the greatest amount of heat must be exposed to the warmest parts of the oven, while others of a lighter grade should be placed in positions likely to afford the heat expected and required.

From this point careful manipulation is requisite, other-

wise the goods may be burned or calcined instead of being annealed. Nothing but practice and experience can help here, and care must be taken not to hurry the heat; therefore two or three days is quite usual for getting the oven up to heat, and altogether ten or eleven days is regarded by some as the time necessary for the operation of annealing "malleable cast."

At the time the fire is extinguished, the damper or dampers must be closed down, and the oven allowed to cool slowly, no air being admitted into the inside of the oven; and assuming normal temperature outside, four days should be about the time for "opening-up" after ceasing firing. The hard castings thus annealed should be converted to the proper temper of "malleable cast," and a good annealed casting should not have over .05 or .10 per cent. combined carbon remaining in it. Any defective annealed casting can be readily detected by its brittleness, but nothing short of long experience will enable a founder to anneal properly and decide when a casting is over-annealed.

PRACTICAL METALLURGY IN THE FOUNDRY

It is now very generally realised that a sound general metallurgical training is of the greatest value to the foundryman if he is to maintain his position, for however great may be a man's practical knowledge and experience gained in the foundry, he cannot hope indefinitely to compete successfully against another with equally good practical experience, who also clearly understands the scientific principles upon which his art is based. Besides what is usually included in the subject of metallurgy, an adequate training in the elementary principles of chemistry, physics and mechanics is essential, for without this it is often difficult for the student of metallurgy to understand and appreciate the value of the theoretical side of his subject. At the same time a practical man however unfortunately he may be situated in the matter of opportunities for scientific education can, if he has the mind, obtain for himself a fair knowledge of how this, that or the other constituent in metal may operate under certain conditions

for good or evil, and thereby inform himself on one of the most cardinal points which go to make a successful founder. Theory, in itself, will never, in the author's opinion, adapt suitable metals for castings, without a good grounding in all that pertains to the fundamentals of practical foundry practice. The behaviour of metals during their passage from the fluid condition right through all stages of cooling until they finally reach atmospheric temperature, "adaptation," "temperatures of pouring" and "position of casting" are questions at times of *vital importance*, and are essential parts of "practical metallurgy in the foundry."

Pig-Iron Brands and their Composition.—Those brands of pig metal that are classed as "grey," are regarded as the most suitable for the foundry trade of grey iron castings, and are usually classed in this grade and numbered from 1 to 4. But in some cases the numbering of brands produced at the same ironworks goes up to No. 8, or even 9 and 10. This numbering of brands is practically determined from the appearances presented by the freshly-fractured surfaces, a certain number of pigs being taken from different parts of the "cast" at the respective furnaces for this purpose. Gradation, being mainly attributed to colour, texture, and uniformity of lustre, the largest grained or most coarsely crystalline metal on the "break," with its graphitic dark grey colour, denotes at once a metal that is soft and fluid, and in foundry parlance, is the metal capable of carrying the largest amount of scrap in mixing for the general work of a grey iron founder's castings.

Beyond No. 4 pig metal, (and, say, more than twenty-five years ago), it was commonly regarded that numbering should cease, and "mottled" and "white" were the terms employed to classify iron which passed out of the colour of grey into the shades of white. But present-day practice has determined a rotation of numbers according to colour and density. The darkest grey being No. 1, the progression is upwards by degrees or shades of colour, the real white being reached about No. 8, but some "brand" after this as glazed and glazed white, or Nos. 9 and 10, every number thus recorded giving an analysis peculiarly its own.

The following are a few of the analyses of English pig metals:—

STANTON IRON WORKS, LIMITED, NEAR NOTTINGHAM.

Brand—"Stanton."

—	G. C.	C. C.	Si.	S.	P.	Mn.
No. 1 foundry	3.38	0.06	3.24	0.028	1.20	0.49
„ 2 „	2.85	0.05	3.50	0.029	1.02	0.40
„ 3 „	3.25	0.31	3.39	0.043	1.16	0.46
„ 4 „	2.32	0.67	2.91	0.065	1.19	0.48
Forge	1.48	1.26	1.66	0.094	1.24	0.38
Mottled	1.28	0.85	0.97	0.200	0.85	0.15
Tiger	1.25	1.40	1.24	0.300	1.22	0.23
White	0.60	1.70	0.47	0.410	1.08	0.13

DURHAM.—BELL BROTHERS, LIMITED, CLARENCE IRON WORKS, MIDDLESBROUGH.

Brand—"Clarence."

(Approximate.)

—	G. C.	C. C.	Si.	S.	P.	Mn.
No. 1 foundry	3.30	0.15	2.8	0.030	1.52	0.60
„ 3 „	3.20	0.18	2.50	0.035	1.52	0.60
„ 4 „	3.00	0.48	2.31	0.075	1.55	0.50
„ 4 forge	2.90	0.62	1.53	0.142	1.50	0.45
Mottled	2.30	0.87	1.31	0.153	1.50	0.33
White	Trace	3.10	0.250	0.250	1.52	0.30
Silicious	3.30	Trace	0.018	0.016	1.55	0.70

YORKSHIRE (NORTH RIDING).—BOLCKOW, VAUGHAN & Co., LIMITED, MIDDLESBROUGH.

—	G. C.	C. C.	Si.	S.	P.	Mn.
No. 1	3.00	0.10	3.00	0.03	0.05	1.00
„ 2	3.30	0.15	2.81	0.05	0.05	0.95
„ 3	3.25	0.20	2.60	0.06	0.05	0.95
“Cleveland,” No. 3	3.37	0.10	3.33	0.05	1.51	0.70
“Clay Lane,” No. 3	3.24	0.18	3.21	0.05	1.52	0.49
“Clay Lane,” White	0.10	1.30	1.30	0.045	1.53	0.30

Moss Bay Hematite Iron Company, Limited, Workington,
Cumberland.

Brand—"Moss Bay."

---	G. C.	C. C.	Si.	S.	P.	Mn.
No. 1 B.	3·60	0·10	3·00	0·01	0·03- 0·04	0·70
„ 2 B.	3·50	0·15	2·50	0·02	0·04	0·70
„ 3 B.	3·30	0·25	2·00	0·04	0·04	0·64
Forge 3	3·00	0·35	1·70	0·07	0·04	0·50
„ 5	2·80	0·45	1·30	0·10	0·04	0·50

THE STAVELEY COAL AND IRON COMPANY, LIMITED.

Brand—"Staveley."

---	G. C.	C. C.	Si.	S.	P.	Mn.
No. 1 foundry	3·45	0·15	3·20	0·01	1·50	0·80
„ 2 „	3·30	0·25	2·92	0·02	1·50	0·80
„ 3 „	3·20	0·30	2·52	0·03	1·50	1·75
„ 4 „	3·05	0·40	2·33	0·04	1·50	0·70
„ 4 grey forge	2·90	0·55	2·30	0·05	1·50	1·70
„ 4 forge	2·70	0·65	2·00	0·08	1·45	0·60
Mottled	1·18	1·80	0·80	0·18	1·40	0·50
White	0·20	2·90	0·50	0·25	1·40	0·30
Glazed	—	—	4·50	0·03	—	—

SOUTH STAFFORDSHIRE AND WORCESTERSHIRE.—T. & J. BRADLEY &
SONS, LIMITED, DARLASTON BLAST FURNACES, DARLASTON.

Brand—"All Mine" (Medium Quality).

---	G. C.	C. C.	Si.	S.	P.	Mn.
No. 1	3·50	Trace	3·50	0·025	0·90 to 1·00	0·09
„ 2	3·20	0·25	3·00	0·040		0·090
„ 3	2·70	0·75	2·30	0·050		0·087
„ 4	2·50	0·90	2·00	0·070		0·085
„ 5	2·10	1·20	1·70	0·080		0·086
„ 6	1·60	1·60	1·50	0·080		0·080

SOUTH STAFFORDSHIRE AND WORCESTERSHIRE.—T. & J. BRADLEY & SONS, LIMITED, DARLASTON BLAST FURNACES, DARLASTON.—*Contd.*

Brand—"IXL All Mine" (Best Quality).

—	G. C.	C. C.	Si.	S.	P.	Mn.
No. 1 H. B.	3·60	Trace	2·80	0·025	0·40	1·00
„ 2 H. B.	3·25	0·30	2·50	0·040	0·40	1·10
„ 3 H. B.	2·80	0·70	2·10	0·060	0·38	1·05
„ 4 C. B.	2·50	0·90	1·20	0·070	0·37	1·00
„ 5 C. B.	2·00	1·30	1·00	0·080	0·37	0·95
„ 6 C. B.	1·50	1·70	0·90	0·085	0·35	0·90

YORKSHIRE (WEST RIDING).—THE FARNLEY IRON COMPANY, LIMITED, LEEDS.

Brand—"Farnley" (Best Yorkshire Iron).

—	G. C.	C. C.	Si.	S.	P.	Mn.
Cold Blast, No. 5 . . .	3·12	0·29	1·03	0·09	Trace	0·46

LILLESHALL COLD BLAST IRON.

Brand—"Lilleshall Lodge."

—	No. 1.	No. 2.	No. 3.	No. 4.	No. 5, ordinary.	No. 5, chilling.	Hard, chilling.	Mottled.	White.
Graphite carbon . . .	3·32	3·20	2·58	2·60	2·62	2·50	2·42	1·50	·35
Combined carbon . . .	·12	·25	·48	·60	·55	·65	·68	1·25	2·25
Silicon	2·00	1·80	1·72	1·40	1·30	1·00	·90	·60	·50
Sulphur	·03	·04	·06	·08	·10	·12	·13	·18	·23
Manganese	1·25	1·15	·93	·84	·80	·65	·60	·45	·35
Phosphorus	·55	·56	·56	·56	·40	·57	·57	·58	·60

LILLESHELL HOT BLAST IRON.

Brand—"Lilleshall H. B."

—	No. 1.	No. 2.	No. 3.	No. 4.	No. 5, not chilling.	--	Hard, not chilling.	Mottled.	White.
Graphite carbon .	3·15	3·05	2·84	2·44	2·50	—	2·20	1·30	·25
Combined carbon .	·15	·30	·40	·50	·60	—	·70	1·20	2·10
Silicon .	2·50	2·30	2·10	1·80	1·50	—	1·30	·90	·50
Sulphur .	·03	·04	·05	·07	·09	—	·12	·17	·23
Manganese	1·30	1·10	·90	·80	·80	—	·50	·35	·25
Phosphorus	·72	·74	·74	·73	·70	—	·75	·76	·77

M. & W. GRAZEBROOK, DUDLEY.—NETHERTON IRON WORKS,
NEAR DUDLEY.

—	G. C.	C. C.	Si.	S.	P.	Mn.
No. 1 . . .	2·70	·32	1·6	·01	·60	·76
„ 2 . . .	2·65	·35	1·35	·03	·57	·72
„ 3 . . .	2·55	·40	1·16	·06	·54	·70
„ 4 . . .	2·45	·50	1·00	·08	·50	·64
„ 5 . . .	2·34	·56	·90	·10	·50	·60
„ 5 H. . .	2·25	·60	·80	·14	·45	·55

LOW MOOR IRON WORKS, BRADFORD, YORKS.

Brand—"Low Moor" (Best Yorkshire Iron).

—	G. C.	C. C.	Si.	S.	P.	Mn.
No. 1 . . .	2·940	·590	1·324	·042	·362	1·096
„ 2 . . .	2·960	·560	1·389	·050	·398	1·065
„ 3 . . .	3·060	·550	1·335	·049	·367	·808
„ 4 . . .	2·870	·680	1·154	·064	·384	·899
„ 5 . . .	2·570	·810	·736	·089	·386	·839

The following are also a few of the analyses of Scotch pig irons:—

Brand—"Glengarnock."
(Approximate.)

—	No. 1.	No. 2.	No. 3.	No. 3, hard.
Graphite carbon	3·50	3·25	3·25	3·10
Combined carbon	·20	·25	·30	·35
Silicon	3·50	3·00	2·50	2·00
Sulphur	·04	·05	·05	·06
Phosphorus	·60	·60	·60	·60
Manganese	1·10	1·10	1·10	1·10

Brand—"Carnbrœ."
(Approximate.)

—	No. 1.	No. 3.	No. 4.
Graphite carbon	3·60	3·30	3·20
Combined carbon	·15	·30	·40
Silicon	3·50	2·60	2·10
Sulphur	·03	·04	·06
Phosphorus	·90	·90	·90
Manganese	1·20	1·10	·92

CARRON COMPANY, CARRON IRON WORKS, CARRON.
Brand—"Carron."

—	G. C.	C. C.	Si.	S.	P.	Mn.
No. 1	3·500	·140	2·800	·035	1·000	1·000
" 2	3·460	·200	2·275	·045	1·000	·995
" 3, soft	3·350	·180	2·650	·038	·999	1·000
" 3, foundry	3·350	·200	2·150	·060	1·000	·908
" 3, close	3·170	·280	1·750	·065	1·005	·850
" 3, hard	3·160	·300	1·570	·070	1·010	·800

JAMES DUNLOP & Co., LIMITED, CLYDE IRON WORKS, TOLCROSS, GLASGOW.

Brand—"Clyde."
(Approximate.)

—	G. C.	C. C.	Si.	S.	P.	Mn.
No. 3	3·2	·8	2·5 to 3·5	·03 to ·05	·4 to ·6	·43

Brand—"Monkland."

(Approximate.)

—	G. C.	C. C.	Si.	S.	P.	Mn.
No. 3	3	1	2.5	.03	.4	.5

The properties of cast iron are regulated principally by the condition of the carbon present, the effect of other elements such as silicon and sulphur being largely an indirect one in determining what that condition shall be. The two chief forms in which carbon occurs in cast iron are graphite and combined carbon. Carbon in the free state in the form of graphite is characteristic of all grey irons, and is found in the form of black lustrous flakes or scales of varying size. Combined carbon is the name given to carbon that exists chemically combined with the iron as a carbide of iron having the formula Fe_3C , white irons containing practically all their carbon in this condition. In the greyest and softest irons the carbon is present almost entirely in the form of graphite, and as the amount of combined carbon increases and graphite decreases, the iron becomes closer grained, harder and stronger. When the amount of combined carbon approaches 1 per cent., the iron, although it may have a high tensile strength, generally becomes unduly hard for most purposes, and an iron having about equal quantities of graphite and combined carbon has a mottled fracture. The relative amounts of graphite and combined carbon in a cast iron are determined partly by the amount of the different impurities present and partly by the rate of cooling. The impurities commonly found in cast iron are silicon, sulphur, manganese and phosphorus, and their effects on the properties of cast iron are as follows:—

Silicon causes the carbon to assume the graphitic form and thus has a softening effect. Silicon also has the effect of lowering the total amount of carbon in the iron, and with more than about 2 per cent. this influence usually becomes marked, the iron beginning to lose its strength without any corresponding increase in softness. Iron cannot under any ordinary conditions hold, when solid, more than a certain amount (about

per cent.) of carbon, and as 1 per cent. of silicon has the power of replacing about 0·45 per cent. of carbon, a high percentage of silicon is liable to lead to the separation of kish before or just at the commencement of solidification, and so produce a dirty iron.

Sulphur has a very powerful effect in hardening the iron by preventing the separation of graphite and keeping the iron in the combined state. Silicon and sulphur thus act in direct opposition to each other, and it is to a great extent by suitably varying the percentages of these two impurities that the founder adapts his iron to the particular requirements of his castings.

Manganese has in itself a tendency to make the carbon exist in the combined state, and so harden it and make it chill easily. It has, however, a greater affinity for sulphur than iron has, and since sulphur, when combined with manganese, has little hardening effect, the nett result of manganese, when not present to the extent of more than about 1 per cent., is to give a soft iron. Manganese thus usually plays the part of a softener in the foundry, especially for iron high in sulphur.

Phosphorus, in the amount in which it is usually present in foundry irons, has no very marked effect on the condition of the carbon as compared with silicon, sulphur and manganese, but is useful in giving fluidity and lowering the melting point of the iron. It forms a phosphide with the iron which is hard and brittle, and this hardness and brittleness become marked when the phosphorus is high, so that highly phosphoric irons are only suitable for the cheaper class of castings and those of intricate design where strength is of little importance.

In addition to the effect of the impurities mentioned, the rate of cooling has a very great influence on the properties of cast iron, since the carbon has a tendency to exist in the combined form when the iron solidifies and cools quickly, while on the other hand, slow cooling promotes the formation of graphite. The rate of solidification and cooling depend to a large extent on the section and size of the casting. Thus a small casting of thin section will solidify and cool very much more rapidly than a large one of thick section; a metal, therefore, that would be suitable for the former would probably, if used for casting the latter, be much too soft and

weak owing not only to the unnecessarily large proportion of graphite and the deficiency of combined carbon, but also to the fact that most of the graphite present would be of large size, this large graphite also having the tendency to give a porous, dirty iron. The composition of the iron, especially with regard to the amount of silicon, must therefore be varied so that, under the conditions of cooling of the particular casting which is to be made, the required softness, strength and texture may be obtained.

There is one very important property of iron, viz., shrinkage, which is very closely connected with the amount and condition of the carbon present. Other things being equal the shrinkage depends on the amount of graphite—the greater the amount of graphite the less the shrinkage; or, in other words, generally speaking the harder and denser the iron the greater the shrinkage.

Amongst the pig irons generally used in the foundry, Scotch No. 1 is usually considered to be the greatest “scrap-bearer” on account of its high percentages of silicon and manganese, and by careful mixing, regulation of temperature, and in some cases by judicious tempering, good castings of any sort, frictional or anti-frictional, may be produced from most of the common Scotch grey, hot blast pig irons with perfect safety. English common grey iron, or Middlesbrough iron is unsuitable for general machinery castings on account of its high percentage of phosphorus. Phosphoric iron does not take a good polish when cast in thick sections, but is all right for range or hollow work in general, since the rapid cooling of the thin sections gives, in the case of iron with high phosphorus, the density and polish required for high-class range metal castings. Middlesbrough iron also, on account of its high phosphorus, is very fluid when melted, and may be poured safely at a much lower temperature than is possible with an iron such as No. 1 Scotch.

All grey brands improve on remelting, although not to the extent that some authorities assert. For instance, Gautier has said that No. 1 Scotch reached its maximum of strength at the eighth melting, and Fairbairn found that the same point was reached with No. 3 pig (Eglington) after twelve

meltings. From a very lengthy experience of using the latter pig metal, I advisedly say this is not correct in practice. The varying conditions of melting, *e.g.*, the character of the coke used and sections of metal cast, have an important influence in determining the number of meltings an iron will stand.

Remelting other brands, such as hematite and cold blast, should not be resorted to, that is to say, if the founder is getting what he is paying for, the oxidation during remelting and pouring having a very marked effect in reducing the fluidity of the metal. It must be borne in mind that every individual melt of metal, soft or hard, decreases fluidity and intensifies the oxide film of every metal in its fluid state practically in proportion to the number of times it is remelted, this decreased fluidity causing an increased tendency to "cold shut."

Grey pig irons vary very much both in quality and price ranging from hard to soft irons at prices as far removed from each other as "hot blast" at 47*s.* to "cold blast" at 115*s.* per ton, at the time of writing. Likewise analyses vary considerably, and physical tests in grey pig metals may be anything between 23 cwts. and 36 cwts. in a transverse test with test bars 2 ins. by 1 in. placed at 3 ft. centres. Such are the wide differences in the varieties of what is commonly known by the term "grey pig metal."

White iron is, comparatively, rarely used, and wherever melted for the castings trade, it is usually mixed up with grey iron for chilled castings of every description, or castings required for anti-frictional purposes, and in the compounding of steel and "malleable-cast" mixtures. Wherever used, this metal must be mixed with more than ordinary care, otherwise it is easy to make a mistake because of its difficulty in mixing thoroughly—evidence of which is to be found too often at the machining of those castings containing a well-selected proportion to give improved density. The chief constituent of white iron is combined carbon, this at times being over 3 per cent., and if backed up by 1½ per cent. manganese, at once accounts for the hard and flinty nature of white iron combined carbon and manganese being the principal "hardeners," for steel and "malleable-cast" castings.

Mottled Iron.—Practically this is the “wedge” between grey and white, and those knowing how to work the one need not fear the other, the analyses of both being found in the previous pages.

Mechanical Tests.—There is a general delicacy in dealing with physical or mechanical tests of the different brands by different iron smelters; and for reasons which may be obvious, we do not dispute the fact. Suffice it to say, that grey irons, hot and cold blast, vary, as previously stated, from 23 cwts. to 40 cwts. on a transverse test bar $3\frac{1}{2}$ ft. by 2 ins. by 1 in., and resting on suitable supports 3 ft. apart. One first-class firm of iron smelters register their tests on a bar of the description given at “37 cwts. for ‘cold blast,’ and ‘hot blast’ 28/32 cwts.”

The following tests, transverse and tensile, were taken recently by the writer for specific purposes, and could be applied to advantage for tests in general machine and special pump castings. But these need not be taken as standard tests, because many good irons never give a bar to dimensions given above 26 cwts. or 28 cwts. as the breaking transverse test; and those irons that are thus low physically are most reliable for fluidity. Consequently their adaptation for pipe castings of all sections is much in evidence amongst foundrymen doing spherical and unpolished work.

Transverse test bars, breaking strain, 3 ft. centres, and calculated to 2 ins. by 1 in.		Tensile test bars taken from the same metals as the transverse bars herein recorded. Dimensions of bar to sketch as illustrated at Fig. 133.	
Breaking weight in lbs.	Deflection.	Tons.	Cwts.
3,450	·452	10	5
3,500	·470	9	18
3,450	·472	10	10
3,400	·475	9	10
3,480	·485	11	10
3,520	·401	11	5
3,440	·397	11	10
3,600	·411	9	18
3,380	·388	10	7
3,420	·390	10	6

Fig. 133 is a common type, to dimensions given, of a tensile bar, and the tests as recorded above are of a higher standard than those common to tests of pig iron for pipe founding, these being usually from 7 tons to 9 tons. On the other hand, tests as detailed are quite good averages for machinery castings in pig metal.

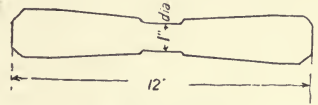

FIG. 133.

Metal Mixing.—In this there is practically no end to varieties and conditions, and from this standpoint, to stipulate any brand or brands in preference to others and the proportion of scrap would not serve a useful purpose. The foundation in this work of metallurgy in foundry practice is a knowledge of the true nature of metals chemically, and by the aid of this, experience will assert itself in adapting mixtures suitable to the varied wants of the foundry.

Chemistry is the base or stepping-stone to foundry metallurgy, whereby we ultimately get a glimpse of the functions performed by the various constituents in cast iron. However, it is not always a question of the best metal turning out the best castings. Thus it has been brought about by experience that, through judicious mixing, control of temperature, feeding, and tempering, castings with improved internal density and capable of taking a superior surface polishing, can be got from inferior brands, to the disadvantage of superior metals where those principles are not observed in practice. Such knowledge of metals as here advanced, wedded to foundry practice, will eventually produce the highest standard of workmanship possible amongst the many varieties of metals in general founding. (See articles, pp. 23, 29, 32, 44, 63, 71, 79, and 153.)

THE MELTING POINTS OF METALS.

“ Platinum	. . .	1,775° C.
Pure iron	. . .	1,505° C.
Steel	. . . about	1,400° C. (but varies with percentage of carbon and impurities).
Nickel	. . .	1,400° C.
Cast iron	. . . about	1,250° C. (but varies with percentage of carbon and impurities).

THE MELTING POINTS OF METALS.—*Contd.*

Copper (pure)	1,083° C.
Gold	1,064° C.
Silver	961° C.
Aluminium	650° C.
Antimony	632° C.
Zinc	419° C.
Lead	327° C.
Tin	232° C.
Mercury	— 39·7° C. ¹

THE BOILING POINTS OF METALS.

Iron	2,450° C. ¹
Copper	2,310° C. ¹
Tin	2,270° C. ¹
Silver	1,955° C. ¹
Aluminium	1,800° C. ¹
Lead	1,525° C. ¹
Antimony	1,440° C. ¹
Zinc	950° C.
Mercury	358° C.

GENERAL PATTERN MAKING FROM A MOULDER'S
POINT OF VIEW

To work a pattern shop most economically it goes without saying that the men engaged must have good tools, not only those that constitute the recognised "kit" of a pattern-maker, but also suitable wood-working machinery, the cost of production in this department being largely determined by the machinery with which it is equipped. Up-to-date shops are provided with the most modern machines for turning out work expeditiously, and the employer then has a right to expect not only superior workmanship, but an output commensurate with the cost of such machine tools.

The first principle to be observed in good pattern making is well-seasoned wood, and unless this is attended to, the best workmanship of the pattern-maker is lost; a pattern made from unseasoned wood, even if the most correct principles of pattern making be observed, is of very little use to the moulder, especially if it be for standard castings or repeat work of any

¹ H. C. Greenwood, Proc. Roy. Soc. 1909, A, LXXXII., p. 396.

kind. As a result, such patterns produce bad workmanship in the foundry, not to mention their comparatively short life caused by the abnormal rapping necessary in drawing them from the sand before finishing the mould.

With this brief reference to general practice in pattern making, what follows will be based purely on what are considered the best principles of pattern making from a moulder's point of view. It may be said, however, that materials and methods must be a question of conditions and circumstances. Hence it is that what may be recognised as good practice in one shop or locality, may not adapt itself as the most economical in other centres of founding; because, as a matter of fact, and as has been previously stated, one firm may make in loam what another would mould in sand, this in itself altering details entirely, without consideration of pattern shop equipment at all. On the other hand whether, for example, a spur-wheel should have double cycloidal, involute, or epicycloidal teeth matters not in the pattern shop, as the principle of pattern making for those castings remains practically the same, the foreman being left to direct methods, materials and workmanship. Consequently the cardinal point at all times in pattern making is to see that a pattern is made *mouldable*, and on the most approved principles for the foundry, based on the lines of economy *commensurate with the quantity required to be made off any pattern*. But as a principle we may take it that the more money that is spent in the pattern shop in the making of good patterns, the greater will be the reduction of costs in the foundry, or *vice versâ*. It is all a question of good management where to draw the line in the departments in question, and from a jobbing moulder's point of view money is frequently lost by making patterns for the production of castings, which might just as well have been moulded by sweep or streakle boards in loam.

Iron patterns are commonly adopted for repetition work—that is to say, castings that are made by the thousand—and wherever the use of these patterns is possible, the highest efficiency as regards economical working and good workmanship is assured. Nevertheless, it must be borne in mind, that

those patterns are only obtainable by first having a pattern in wood, stucco, or other material to cast the iron pattern from. It will be obvious that in the casting of iron patterns, whatever material is chosen, the patterns, as referred to, must be provided with double shrinkage, so that the castings ultimately to be made from the iron patterns will come out when cast, according to dimensions or specifications. This is important, and its effect is emphasised with other metals than iron, where the shrinkages are much greater.

A bank-pipe pattern (Fig. 134) is a cast-iron pipe pattern used for moulding common bank pipes in green-sand, and the principal precaution to be observed is to make sure that enough metal is allowed for finishing the iron pattern to dimensions. The patterns are first of all generally made from wood, and as a rule are turned out of a solid piece of

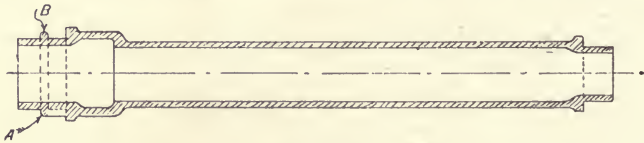

FIG. 134.

good white or yellow pine. No halving or jointing of these patterns being necessary as is common to most cylindrical pattern making, there is no reason why the larger diameters at least, should not be made from loam "bosses" by a duly qualified core-maker; and by this method, the cost of the pattern is reduced to whatever time and money is spent in producing the loam board by which the "boss" is made together with the time in making the boss pattern. This is simply a process of first and second coating a loam core in the usual way, and after the second coat is dried and while it contains a considerable amount of heat it should be "tarred." The tar then hardens and strengthens the loam with which it is made, thus practically completing a boss or pattern substitute, thoroughly adapted for the moulding of cast-iron bank-pipe patterns of the diameters suggested, and at a cost considerably less than is possible with somewhat similar patterns made in wood (see p. 92).

These patterns should be cast and made to finish, say, from $\frac{3}{8}$ in. to $\frac{1}{2}$ in. thick. It will be noticed that Fig. 134 is a longitudinal section of the pipe pattern in question, this view being principally employed to show the pouring gate *B*, (Fig. 134), which, as will be seen, is on the faucet end of the pattern. This gate *B*, with the exception of the vertical part not shown, is cast on the pattern, and encircles the *core-bearing*, as indicated by dotted lines on the illustration. Whether such a pattern as illustrated here be made from wood or of loam as suggested, the admission gate *A* (Fig. 134) obviously must be put on after the pattern is practically finished.

The simplest way to make this admission gate *A* (Fig. 134) is to get a flat wooden pattern of the section desired for "running" the mould; cast this in lead, and coil it or sprig it on to the bottom side of the pattern according to the distance which determines the size of gate on the faucet end of the pattern, as shown at *A* (Fig. 134). When this has been done, we have completed the boss or pattern for moulding a cast-iron pipe pattern for green-sand bank-pipe moulding.

Bank-Pipe Core-Boxes.—Core-boxes made for this class of core making must all be abnormally strong, so as to withstand the rough usage by force of circumstances to which they are subjected by the core-makers, a practice of core making peculiar to the work of bank-pipe casting.

These core-boxes are of cast iron, and are made, of course, from wooden patterns, but by interchange with their hinge pattern attachments and other staying supports, it is not necessary in making these patterns to have more than one half with which to make a complete cast-iron core-box for "bank-pipe moulding."

The core-boxes for 9 ft. length castings are made from $1\frac{1}{2}$ ins. up to 10 ins. diameter. Nevertheless, these boxes are all wrought or operated by hand, and in the opening and closing of them during the process of core making a short lever is applied through the hole *A*, as seen at Fig. 135. The hole *A*, as referred to, materially assists in *throwing* the core-box over at the time of jointing in the process of ramming the core, previously to finishing it; the hinges

meantime keeping all correct for what is evidently to many a novelty in core making.

Cores of this class are all made on strong benches, which facilitates this process in core making, and no machine has as yet supplanted this method for speed, good workmanship, and accuracy.

The core-boxes being made in halves are all machined accurately so as to produce pipes internally correct, and after marking off and carefully centering the halves, the hinges should be fitted so as to ensure free working, and close face to face joints. Thereafter, bore the ends for a short distance. When done, the rest of the metal should be machined by planing. This plan has been found to give better results than boring with a cutter bar the entire length of these core-box castings.

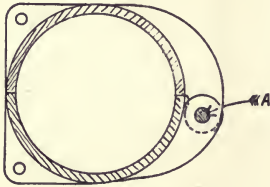

FIG. 135.

The extra care thus taken with pattern and core-boxes for bank-pipe moulding pays for itself over and over again, and the method of machining the core-boxes as suggested, even although it may

appear expensive, is a guarantee that all castings made therefrom will be absolutely straight and true, resulting in the highest possible output of good castings.

Pit Bogey-Wheel Patterns.—Fig. 86 has already been used to illustrate gating, but there is no reason why it should not again be used to illustrate pattern making, and at the same time serve to illustrate chilling also, *A* being the chill; the rest will explain itself. These wheels may be moulded with one, two, or four in the box, but no matter which number is adopted, they must be moulded with iron patterns, either with “turning-over board,” or on the plate principle of moulding. But, whatever principle be accepted, chills, as shown at *A*, Fig. 86, require to be cast from a wooden pattern to the section in the figure referred to. In making separate wheel patterns and chills, briefly, the pattern for the chill is first turned up in the lathe, one of course to each; thereafter the wheel is made to fit the chill, all

according to specification, and as chill and wheel pattern should shrink very nearly alike, both ought to be cast as soon as possible before warping or twisting sets in with chill or wheel pattern. Cast-iron patterns of this class, before using, should be rusted, then cleaned thoroughly, and with a workable warmth should be rubbed and brushed up with bees-wax. Iron patterns so treated, whether they be of plain or pinion-wheel design, will *draw* from the sand as well as the best painted and varnished wooden patterns.

Condenser Patterns.—With castings of this type (see “Gates and Gating,” Fig. 88), we are at once confronted with three distinct methods of pattern making, and for the various types of these castings each of the methods may appropriately be considered in this division of pattern making. These may be classified thus:—(1) Building a boss by brick and loam, and thereafter planting the branches, according to the drawing of the casting, to be made during the process of cope building as time and convenience demand. (2) Crate-frame pattern with no sweeping of body, but branches fixed in the usual way. (3) The streakle board set to spindle according to loam practice, cope and core built separately, and the branches planted to drawing according to loam moulding practice.

In the above are shown three distinct methods of pattern making, and as everything in general workshop practice in the end resolves on *£. s. d.*, it means at times not a little thinking to determine which is the most economical to all concerned. It may be said, however, that where the moulder can have a pattern-maker in attendance, the third method, is by far the best, no matter from what view-point we look at it.

In the first method we have got to consider the amount of brick and loam the boss (which, of course, is the body pattern) would require, and the time it would take to make it. When all is built, and roughed with loam and skinned up, it has got to be painted over with clean water blackwash (preferably from wood blacking), which is applied so as to secure the boss from clogging to the cope to be built against it. Wherever this practice is adopted, all branches should be a little longer than actual measurement from “boss” body to their respective

faces, say, $\frac{1}{4}$ in. This admits of indenting these branches into the body, which becomes a factor of security in so far as keeping them in their places during the operation of building the cope is concerned.

Second, with a "delf-crate pattern" (foundry parlance) the amount of wood required for this, the slimmest pattern construction possible, means a bill for cost of wood that, even to an experienced man, is somewhat astonishing. Nevertheless it has been done, and what has been previously performed may be repeated, but the practice is economically bad. Briefly put, the materials used for the loam boss are all taken up at the building of the core; it is only a question of cleaning the brick thus used, and with the remilling of the loam more than enough material is secured, from what previously constituted the boss, for the building of the core. This may appear fairly plausible, but the "boss principle" of moulding loam condensers (Fig. 88) of the type herein referred to is not at all, in the writer's opinion, commendable—at least, wherever the pattern-maker can be in attendance for the placing of the branches during the building operations of the cope, as has been previously stated.

However, delf-crate patterns in many forms and types are used to advantage, but not of the cylindrical section and size herein considered. But in the case of oval sections and such like where only "one off" is wanted, their utility is an advantage, as a rule, both in practice and economy.

Third, by building cope and core by the usual methods of loam moulding, we at once get rid of the innumerable composite parts of a delf-crate pattern. And again, the materials, brick and loam, and the cost of making the "boss" for the body pattern of this job all combine to prove the utility of making these condensers, as illustrated at Fig. 88, with cope and core, and streakled or swept according to the usual method of loam moulding. But it must be borne in mind that the third proposition or method necessitates intermittent attendance from the pattern-maker throughout the operation of building the cope, so as to place the branches in their proper places, as the cope stepwise is built upwards towards its finish.

All that has been referred to is included in the cost of the

body pattern for the condenser in question, and it must now be considered that, no matter of what form or section the body of the mould may be, the question of cost of the accompanying branches remains practically the same. Nevertheless, the different methods mentioned necessitate different conditions in practice:—(1) For a boss we require to make the branches about $\frac{1}{4}$ in. longer so as to admit of this amount of indentation from the branches to the boss, and thereby secure them from shifting in the process of building. (2) With the crate pattern as suggested, their exact lengths from centre of body to their faces are required, and they must be fastened according to general practice. (3) For planting or placing in the upward movement while building, as previously referred to, all branches must be kept short enough to guarantee absolute clearance for the cope board, throughout the building operations of the cope from start to finish.

Whether the cope or core take precedence in building is matter for the moulder to decide; either way is only an inversion of detail to the pattern-maker without additional cost to this department.

All that a pattern-maker requires when in attendance on loam moulders are a special straight-edge, square and plumb-line, the first having a hole in its centre to suit the spindle. In addition, it will be of advantage when using such a straight-edge at the setting of these branches if the centre line be drawn, and also a section of the metal at both ends to the diameters wanted.

Further, to simplify the placing of branches and other attachments, the cope board should have the bottom surfaces of all these drawn on it very distinctly, so that when reaching those lines, all the moulder has to do is to screw a small chamfered board on to the cope board, and by this means he makes or sweeps a flat surface sufficient to steady any branch or projection exactly on the spot specified in his drawing.

This bare outline in condenser founding is but a brief account from actual practice, and it must never be forgotten that the key to success in pattern making lies in a mastery of

the fundamentals of moulding (at least in so far as it concerns the making of moulds in the foundry).

Stucco Pattern Making.—Stucco as a device in pattern making is generally admitted to have had its origin about the middle of the last century, and for economical pattern making in spherical and light sectional work it is invaluable. While a book might be written on stucco-pattern making,

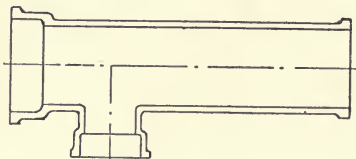

FIG. 136.

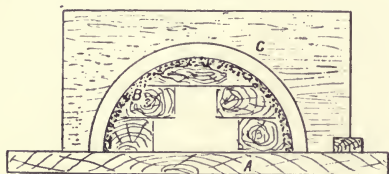

FIG. 137.

and illustrated profusely from the many divisions of founding wherein its application would be most serviceable, a text - book such as this can only admit of a very few brief references that involve stucco practice.

This division of pattern making is largely confined to the "hollow" and pipe foundry trades. Still, many other departments of pattern making in general

engineering and jobbing shops might introduce this method or process of pattern making to much advantage, as this would be specially serviceable where only "one off" in cylindrical section castings was wanted. Or, on the other hand, if a similar requirement for a cast-iron pattern for repetition work was needed, such as in the "special pipe" trade, where, as a rule, nothing but cast-iron *shell patterns*, for small and medium diameters, as seen at Fig. 136, are in use, a stucco pattern for its production in point of economy and good practice becomes imperative.

Fig. 136 shows in longitudinal section a branch-pipe pattern in stucco, which is made in three separate parts thus—branch, body, and end faucet, separated according to circumstances. In dividing the end faucet from the body, care must be taken to see that the place of division will serve for again dividing or cutting the body through equidistant from the centre of the branch shown on Fig. 136. By

arranging as suggested, we thereby secure this stucco pattern for making "rights" and "lefts" in iron which constitute a shell pattern in halves for standard work in special pipe founding.

Fig. 137 shows Fig. 136 in section (although on a larger scale). *A* is the board for sweeping the "block" on, and *C* the sweep which requires no explanation, giving a good rough core block in wood, with a minimum of clearance for stucco, as seen at Fig. 137, and when finished, board *A*, and core *B* in this figure may combine to make a good pattern and turning-over board for the foundry.

Now, whether it be tees, angles, or curves in this division of pattern making, what applies to the one practically applies to the other. Therefore, if the principles, as enunciated here be intelligently mastered, their application in practice should become easy in making stucco-pipe patterns for the foundry. It should be noted that stucco sweeps are usually cut to the core diameter first, and thereafter the same sweep is altered to the outside diameter of the casting, thus making the one sweep do both for core and "thickness of metal," as will be seen by referring to illustrations in stucco pattern making (Figs. 136, 137 and 138).

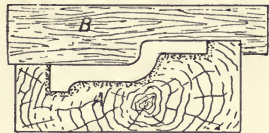

FIG. 138.

Further, for jobbing cast-iron shell-pipe patterns it is better to have, at least, all branches detached, and if the hole on the branch of the body be a good average diameter, the casting of branches of various diameters becomes exceedingly handy. All the same, standard patterns should be of standard completeness, if the highest possible output of the moulder is imperative.

But variety being the order of the day in special pipe founding, it is amazing the smallness of cost this branch of pattern making entails, with pipes that are cast from "shell patterns," when compared with those that are cast in the usual way with loam core, or dry-sand core, made from a core-box and pattern, or otherwise. In a special pipe foundry hundreds of tons are cast that never cost a cent in the

pattern shop unless at an odd time it may be for a plain stick as template, to determine the length, etc., of the casting, all being done by the moulder in the foundry by faking and planting the various pattern parts that go to make what is wanted according to sketch or drawing.

In special pipe foundries a large assortment of "short lengths," of the popular diameters are kept in the pattern store, with faucets and spigot-end pieces to match. These pieces vary in length from, say, 6 ins. to 12 ins. and as a matter of fact "odd specials," (and at times bends also) are moulded from this odd lot of pattern pieces, by the aid of a template determining both body and branches. Two faucets or a faucet and spigot, as the case may be, are bedded endways to template, which thus determines the length. These parts secured, the short lengths, one, two or more in number, and to the diameter wanted, fill in the space between the end extremities, and with the branch, or branches placed according to sketch or template, the pattern is thus so far completed.

At this stage preparation is made for ramming the core, and after the core is rammed up in green-sand core fashion the top piece to every single piece bedded, which make up the bottom part of the pattern, receives its neighbouring top piece. Thereafter, with the core completed, the pattern is there and then secured for whatever is to follow in moulding an odd special, in the green-sand special pipe department of moulding from shell patterns, that are made on the principle previously stated.

In connection with this important branch of foundry practice, we add that whether it be odd or standard specials, the cope is next rammed up, and when parted the core is lifted out and finished along with the mould. When all is thus completed the green-sand core is returned to its "*bearings*," and the cope being now placed over the core, the moulding, thus briefly described, of special pipes from shell cast-iron patterns is finished. With this method of pattern-making exception may be taken by some who are unaccustomed to it, and who are of opinion that solid or built wooden patterns, with their accompanying core-boxes or loam boards, are in all

cases superior in practice. Suffice it to say that stucco pattern-making is Scotch special pipe foundry practice in green-sand, and that being so, he would be a bold man to condemn what has been so long in practice with a class of founders who, as a rule, are not slow to adopt new methods of economical production. The whys and the wherefores of both methods, viz., "shell," or wooden patterns and core-boxes, are certainly of much interest for those who have to do with special pipe founding, but for obvious reasons cannot at present be further discussed. This slight digression from the pattern shop to the foundry, in consideration of its importance, requires no apology, and it must be borne in mind that in stucco pattern making, as with other methods in practice, a full-sized drawing of any pattern to be made is, as a rule, an absolute necessity.

Stucco Faucet Pattern.—Fig. 138 shows the front elevation (in section) of a stucco faucet pattern, and in some cases the principle, as illustrated by this figure, is extended to the full length of the pattern (if it be a tee-piece or such like), and, of course, *minus* the branch or branches. But the separating of the body, especially with the larger diameters of shell patterns, is in ordinary practice handiest by sweeping these branches and faucets separate from their bodies. Thus separated, it is an easy matter to place all the pattern pieces while moulding what is to complete the cast-iron pattern as a finished job.

Again, at Fig. 138, as will be seen, the ends are cut to the internal diameters of faucet and body, and the sweep *B* of this figure represents the placing or sweeping of the internal diameters. It is well to remember that this box or block *A* (Fig. 138) for moulding this faucet pattern in stucco may be anything in the bottom, so long as due care is taken that the sweep will get working clear to the outside diameter, when preparing it to mould the stucco pattern, as illustrated in section Fig. 138.

Faucets in stucco pattern making may also be swept by spindle and board in the vertical position like any other core thus treated. Thereafter in due time the pattern is separated from its block and sawn in halves suitable for moulding.

Bell-Mouth Stucco Pattern.—Fig. 139 represents this pattern

without dimensions of any kind, these being of no practical purpose for showing the principle for making this pattern in stucco. It will be observed that it is not practicable to sweep the flange, as shown at *D*, Fig. 139, in stucco, and it must of necessity be made of wood and fitted on to the stucco pattern as made from the sweep *E* (Fig. 139), which is wrought from a small pin *C* attached thereto, thus securing the sweep for its work, as illustrated at Fig. 139. The board *A* being secured for this job, the core or block *B* of this figure is afterwards swept in stucco, which in turn is allowed to stiffen, and after being coated with oil (which as previously stated is for parting purposes) the thickness in stucco, as shown between the space of block *B* and sweep *E*, is next put on, thereby completing

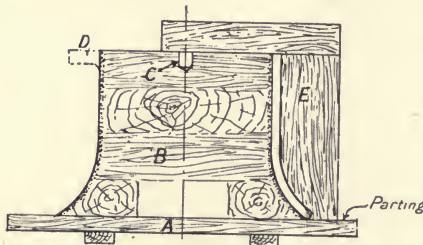

FIG. 139.

the formation of the body of this bell-mouth pattern, as illustrated by Fig. 139. With this pattern painted and varnished, and the flange *D*, which is in wood, made, we have here a complete pattern ready for the foundry.

To a pattern-maker of experience the economy exhibited in this process of pattern making, when compared with wooden patterns of a similar type, is too apparent to admit of dissension; indeed, stucco practice, as illustrated by Fig. 139, is capable of producing as much good work in hours as that of days on similar work when made in wood, and the more conical in section any design may appear, the cheaper the relative cost of production in stucco pattern making becomes.

However, stucco has its limitations in the pattern shop also, therefore one would do well to *discriminate between it and loam for similar purposes*, especially where castings or patterns are wanted at the cheapest rate possible.

Mixing Stucco.—The trough or box used for this purpose should have plenty of taper, so that no impediment may be experienced in removing the hard stucco. Before proceeding to mix stucco, one's hands should be well coated with

oil, and the water with which it is mixed should contain a little Irish lime, which will make the stucco more constant while working it; and the least possible time occupied in all operations is always productive of the best possible results.

Loam ; Special Pipe Pattern Making.—In pattern making for pipes we may take it that no class of work gives such scope for variety of methods in making patterns as does that of jobbing pipe moulding, light and heavy. This is not confined to any particular branch of moulding, green-sand, dry-sand and loam being alike in this respect. In green-sand moulding solid, skeleton, shell, and other kinds



FIG. 140.

of pattern, which it is not necessary to enumerate, are used, and dry-sand moulding is accommodated on similar lines, with the exception of the "shell" pattern which is seldom used above 12 ins. diameter and in some foundries confined to the green-sand department exclusively.

But for repeat work, save a few possible exceptions, nothing can surpass for speed and accuracy a good pattern and core-box, with a complete and suitable plant, the exceptions bulking largely amongst the larger diameters of "specials" in a pipe factory where variety is predominant and repeat work is practically unknown.

The best pipe factories, as a rule, do not recognise dry-sand moulding for "specials"; thus all above 12 ins. diameter as a rule are moulded in loam, quite the opposite of jobbing foundry practice, as narrated at p. 89 on "Special Pipes and Patterns."

The foregoing process, where only one, or, say, only half a

dozen are wanted, is the most economical for large diameters, and its superiority in producing first-class castings has no equal, with usual care in the foundry.

The process of moulding specials in loam is of a two-fold character : first, by cross and spindle in the vertical position ; and second, by arranging the spindle to work, practically, the same board horizontally, and according to ordinary loam practice.

All the cost of pattern making for this method of moulding "special pipe castings" in loam (in pipe factories) is confined to a few sweeps, as will be seen further on. And instead of patterns, and core-boxes, or other adjuncts for the same purpose, the vertical and horizontal methods of moulding are embodied in the section on "Loam Moulding" in the



FIG. 141.

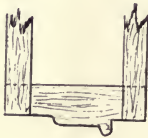

FIG. 142.

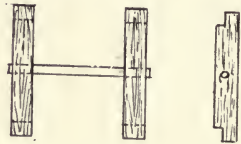

FIG. 143.

second division of this work. For the present, then, we pass on to describe the most that can be said from a practical moulder's point of view in connection with loam moulding of special pipe castings.

Fig. 140 is a plain frame of an 18-in. pipe which is cast about $\frac{1}{2}$ in. thick, and is the base of all operations for sweeping this or similar moulds, in loam. Fig. 141 is the body sweep, and Fig. 142 shows the faucet, and this sweep is made to revolve as seen at Fig. 143, the principle of which is carried out at both ends of the mould to form spigot and faucet.

The bottom of the mould being completed, a sweep (Fig. 144) is made to the diameter of core, viz., 18 ins., and is used for sweeping on the thickness of metal, with either sand or loam on the bottom of mould ; this, being completed and dried, forms a substitute for a core-box. The last sweep handled at the making of the core is shown in Fig. 145, and is worked from one of the outsides of the frame which is illustrated at Fig. 146 with sectional elevation complete, right from the bottom of

the moulding-box *A* to the top of core-sweep *F*. Briefly put, Fig. 146 reads thus :—*A* is the box or casing, *B* bricks or sand, *C* thickness of metal, formed by sand or loam as stated ; *D* is the core and core iron, *F* the top sweep for finishing off the core. The insignificance of pattern shop requirements for moulding specials in loam are herein manifest to a degree, and the absence of the top cope, as shown in Fig. 146 obviously requires no explanation since pattern making is the subject under consideration ; the details as illustrated, from a moulder's point of view, need not be taken seriously.

Spur or Tooth-wheel Patterns.—More than twenty-five years ago many predicted that wheel patterns for this class of work would be likely to become a thing of the past, being replaced by the machine-moulded wheel, but prophecy has



FIG. 144.



FIG. 145.

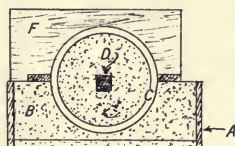

FIG. 146.

been stultified in this, as in many other things in foundry practice, because the wooden pattern with its teeth in finished completeness is still not without its many admirers. However, as has been pointed out elsewhere, both have their place from an engineering point of view, as well as in the foundry ; consequently, it is one of those questions of engineering economics which is left for managers alone to decide. Hence, the merits of either for speed, accuracy, and economy are not disputed, further than to say that with many diameters and pitches, the machine-moulded tooth wheel is not the most economically produced casting of its kind in the market, and where a pattern can be had in time of extreme need, as, for example, in the case of a "breakdown," the pattern-moulded wheel may be got in one-fourth of the time required to cast the same wheel by machine moulding and core-boxes. Moreover, in the case of a wheel from 4 tons to 6 tons, and, say, from 3 ins. to 4 ins. pitch,

experience has proved that a wheel pattern can be made, and all necessary plant for moulding it, and the casting produced also, at a cost *within the buying price* of a machine-moulded spur-wheel casting.

Reducing or increasing Breadth or Depth of Spur-Wheel Castings.—This is a practice that ought to be absolutely confined to the foundry. Many firms destroy to a certain extent their catalogued patterns by cutting or reducing the breadth of the teeth for ordinary or emergency needs. This is a waste that need not be, because wheels may be broadened, or made deeper than any given pattern by the moulder at comparatively little cost, while the pattern remains intact, thus saving to a considerable extent time and money in casting these wheels, under emergency or ordinary circumstances.

With this class of wheel castings, of course, some are shrouded, capped, or flanged, but these terms being synonymous, we shall for convenience classify these castings as capped and plain wheels, and the latter, being those most easily made in the foundry, we shall illustrate and deal with these first. But, whether capped or plain—and no matter whether it be a case of reducing or extending depth in the mould, which of course means additional breadth to the casting—all must be done to bring out the boss at an equal “divide,” top and bottom, in the mould, and its original proportioned breadth of boss in the casting. Further, in all that follows on the manipulating of a pattern on the lines suggested, we shall keep exclusively to a 6-ft. diameter wheel, and, say, 3 ins. pitch, and 12 ins. deep or broad, as illustrated by Fig. 147, so as to simplify the description of this method of moulding wheel castings, as practised by the writer for many years. If proof were required to show how pattern shop and foundry can work together for the greatest good of any firm, we certainly have it in “reducing or increasing breadth or depth” of wheels from standard patterns. As a matter of fact, a spur wheel 6 ins. deep can be moulded and cast from a pattern 12 ins. deep, or *vice versâ*, by following the instructions accompanying Fig. 147, or any other alteration of breadth within reasonable limits.

And, in order to comprehend or fully understand the *modus operandi* of increasing or decreasing breadth of spur wheels *in the sand* during the operation of moulding the main point is to study closely the Figs. 147, 149, 150 and 151, illustrating this practice which, with all things considered, does not create much additional cost, unless when "decreasing" takes place; but, on the other hand, when "increasing" takes place, there is usually a gain in the extra weight fairly commensurate with all the trouble involved by this process. It will be an advantage to observe that these figures are in double sectional elevation, first showing on the right hand the position of the job before parting, and

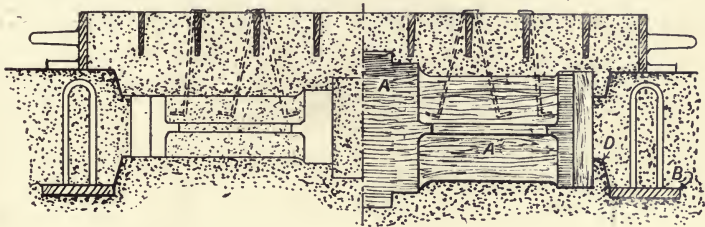

FIG. 147.

second, its finished condition on the left-hand side of the figures referred to, with the alterations wanted.

Reducing Non-capped Wheels.—At Fig. 147, *A* is the pattern which is supposed to be in its original form 12 ins. deep; *B* is the ring which lifts out the teeth for the purpose of cutting and filling up the 3 ins. remaining on the bottom of the mould to the parting line, and finishing it off in the usual way with the ring *B* separated from its bearings.

The foregoing in some instances will doubtless suffice to give practical men, hitherto unacquainted with this sort of trick in wheel moulding, as much information as should enable them to do it for themselves. Still, with others it might be pre-supposing too much if no more information were given. Therefore, the process may be thus briefly described:—Bed down the pattern in the usual way, and after it has been rammed and secured, the bottom parting is then made, which determines the cutting line of the bottom ends of

the teeth, as seen at *D* (Fig. 147). The ring *B* is at this point bedded in, thereafter the parting is made to sweep (Fig. 148); this sweep is cut on one side to 9 ins. for the bottom parting, and 3 ins. to suit the top one. Great care must be exercised in the formation of these partings, because whatever these are swept to, the same determines the breadth or depth of the casting. A study of the partings, and a sketch also of whatever figure be under consideration, will enable those interested to compare this sketch with the following descriptions of any of the wheels represented by Figs. 147, 149, 150 and 151. The procedure thus mastered, the propositions as laid down become comparatively simple to practical men. Lastly, when finishing top and bottom sides of the boss (Fig. 147), get a print the diameter of

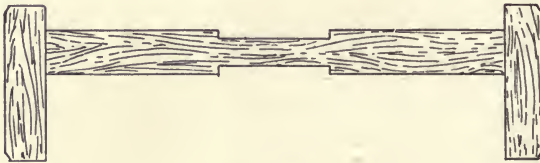

FIG. 148.

core wanted, and have it to project from the faces of the boss to the amount it is to be cut top and bottom. Thus we see the print referred to serves a two-fold purpose—first, to give the diameter of core; and second, its thickness becomes the guide determining depth of boss as seen on left-hand side elevation of Fig. 147.

Increasing Breadth of Non-capped Wheels.—Without going into details concerning the process of increasing the breadth of spur wheels of this description, it will at once be seen that Fig. 149 is an inversion of Fig. 147, as this job is simply begun with a pattern 6 ins. deep, and finished off with a mould 12 ins. deep as illustrated and explained. In further reference to Fig. 149, we at once see that the commencement of moulding is practically the same as Fig. 147, and the first extension of 3 ins. is illustrated and written in plain English, “mould.”

It ought to be mentioned that the space referred to is formed after the pattern is completely rammed up to the top

of the teeth, thoroughly tightened, and drawn with great care to the point desired. But, whether a 6 ins. deep pattern should be drawn 3 ins. at once, instead of by two separate *draws*, is a matter of opinion. However, I should say that by adopting the latter method results will undoubtedly be more satisfactory.

On the pattern being drawn to the exact spot, it is thereafter made a fixture in its mould by tucking and ramming carefully all round the webs of the arms, thus securing it for finishing off the additional ramming of the teeth with safety, thus giving the full depth of the teeth or casting when moulded, as illustrated at Fig. 149.

So far, we see, this last movement means a blank of 3 ins.

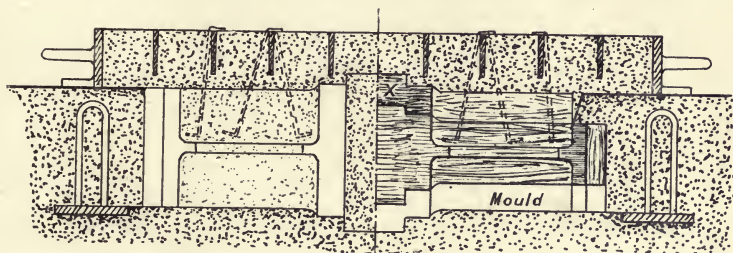

FIG. 149.

in the teeth of the pattern, until the top part is rammed up and the box parted. On this being done, the moulder must now remove the *blank sand* from off the top of the teeth (see Fig. 149). This done, he next draws his pattern with usual care to the parting line, and when here, and fixed exactly to the depth wanted, the top or last extensions of the teeth are rammed according to the practice of securing teeth, and swabbed with water, etc.; the pattern is then in turn completely taken from the sand, thereby completing the extension of moulding a non-capped spur-wheel casting 12 ins. deep from a pattern only 6 ins. deep.

The new pattern pieces for this method of increasing breadth are made up of additional parts for the arms, as illustrated at Fig. 149, and a similar extension to the depth of boss, shown thus, X, on Fig. 149, embraces all that is necessary from the

pattern-shop for increasing the depth of a non-capped spur wheel. Truly an economy in this division of foundry practice, and most commendable where there is a pattern to work from.

It is scarcely necessary to add that the ring *B* in Figs. 147 and 149 is used entirely for the convenience of finishing off in superior fashion what might otherwise be inferior teeth in these castings. The meaning of this will, doubtless, be obvious without further explanation.

Reducing a Capped Spur Wheel.—A glance at Fig. 150 shows, on the right-hand side, in double sectional elevation the change that is made in a pattern 12 ins. broad, rammed up in the floor, while on the left-hand side of the same figure

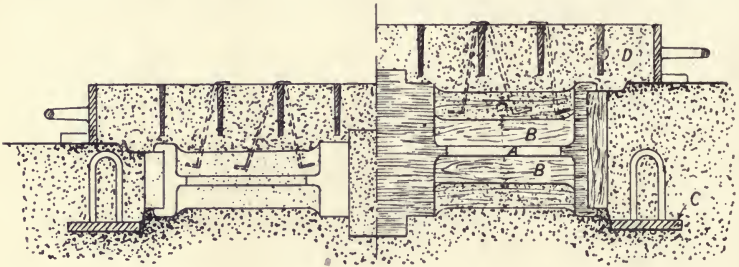

FIG. 150.

is seen the mould 6 ins. deep, which has been transformed by the moulder to the reduced condition. Clearly this change is most pronounced, and the process is altogether different from the one described in Fig. 147.

Nevertheless, the *modus operandi* of moulding this job is practically the same as that of the previous two examples given in moulding "non-capped spur wheels," that are either reduced or increased in breadth. With this explanation of moulding procedure we confine our remarks more especially to the pattern and its adjuncts.

Assuming the core print to be correct on any given pattern chosen for this purpose, and that all other dimensions (of course, except breadth of teeth) are to specification, it must now be noted that nothing is taken away, and whatever alterations are required for this job become purely a question of

how much a-side (new wood) is to be put on the pattern of any capped wheel, to be altered for reducing the casting, say, from 12 ins. to 6 ins. Further, whether it is a reduction from 12 ins. to 6 ins., or any other breadths or depths that may be considered, it is, first of all, an operation in the pattern shop of dividing the difference by cleading both sides of the arms of the pattern in the aggregate equally with wood to what is wanted, when considering the reducing of capped spur-wheel castings. Hence in the reducing of 12 ins. to 6 ins. there must be 3-in. pieces of wood (*BB*, Fig. 150) nailed on the flat faces of the arms; also, any additional wood that may be required to retain strength and symmetry, and strength of "feather" on the arms of the casting.

A study then of Fig. 150 becomes imperative—*A* is the original "flat" of the arm of the pattern, *BB* are the 3-in. temporary or extension pieces that are used for the reducing movement with this pattern, *C* is the ring as previously referred to, and *D* is the top part.

The pattern, as illustrated with its cope rammed up, is ready for parting, and when the cope is removed the moulder immediately sets about to reduce by cutting and scraping with the sweeps, not illustrated, but made in a similar fashion to Fig. 148. The 6 ins. the moulder has previously arranged for scraping out must be done to size with a short sweep, suitable for working between the respective arms of the wheel pattern; and, with the scraping of both outside and inside partings, by these 6-in. checked sweeps, and thereafter the finishing, completes the production of a mould for a 6-in. capped spur-wheel casting from a pattern 12 ins. broad.

From a moulder's point of view it may be permissible to add that the eyes of the ring *C* (Fig. 150) must be kept 6 ins. short (*i.e.*, when bedded in), otherwise, if placed to correspond with the unaltered depth of the pattern (12 ins.) much trouble would arise when returning the cope to its position as seen on left-hand side of the figure in question.

Increasing Breadth of Capped Spur Wheels.—Fig. 151, in a sense, is a repeat of Fig. 147, at least, in so far as the movements of drawing the pattern for extension are concerned. The amount of pattern making is provided for by having

sufficient clogs or blocks of wood for the entire increase on the top half of the pattern. Therefore, assuming it to be an increase of 6 ins., the blocks must be 3 ins. deep, firmly fixed to the circle or rim of the wheel, and placed to suit the pinholes of the cap segments that encircle the pattern. Herein is explained the whole of the pattern making for increasing depth of mould on the lines suggested; and, with the caps thus arranged, there is but little else to add except to say that the method of ramming and drawing the pattern is that laid down for Fig. 147. Also the movements of "faking" and manipulating for a finish being all the same, we only emphasise the importance of knowing in

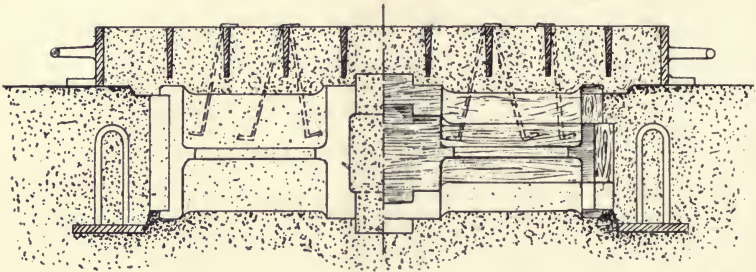

FIG. 151.

detail all connected with these figures on "special spur-wheel moulding," either with or without caps, as the case may be. Moreover, we may take it that just in proportion as we master the various movements, which have been illustrated, of this most important and economical branch of foundry practice, so will our successes in handling this work—which is quite simple in practice—be proportionately secured. See page 87 for further information on pattern making.

FOUNDRY OVENS AND THEIR CONSTRUCTION

Probably there is no question in founding on which opinion is more divided than that of foundry ovens, and in point of fact we find that ovens are as varied in their construction as the buildings that bear the name of foundry. Hence it frequently happens that in the most primitive types of

foundries we find the improvised fire, with its plate resting on bricks over the top of the flame, drying small bench cores with an evident waste of fuel certainly not common to modern up-to-date core ovens, which may either be fired with gaseous or solid fuel. However varied the larger ovens may be in their construction, the greatest difference lies in the method of firing adopted, *i.e.*, whether solid or gaseous fuel is used. Ovens using solid fuels ("fuel ovens") have solid walls and floors, but in the case of gas ovens the walls and floors are as a rule more or less hollowed, with flues for combustion.

Construction.—In the first place we notice that all ovens must have a chimney to carry off the steam and smoke and to give the necessary draught for the combustion of the fuel, whether solid or gaseous. It is not proposed to discuss at any length the question as to which are the more economical, "gas" or "fuel" ovens, since it depends largely on the individual requirements and conditions in each foundry. In a general way it may be safe to say that, in jobbing foundry practice at least, nothing can surpass the old-fashioned type of oven with its solid walls and floor, and with the vent or outlet flue in the floor or the extreme bottom of either side wall.

There are some whose idea of an oven furnace or fire is simply to form a box-like structure in a corner of the oven which is most convenient for firing; and with the necessary fire-bars resting on a piece of cast iron, front hearth-plate and back hearth-plate, and perhaps with an improvised door only, their furnace is complete. Fireplaces of this type cause poor combustion and inferior distribution of heat, which result in additional cost of fuel and extra cost of time for attendance. It is important, then, in the first place to provide sufficient draught for the complete combustion of the fuel; and a fireplace, such as is illustrated in Fig. 152, will, when connected with a suitable chimney, be found to answer admirably for the heating of foundry ovens. It is not necessary to have a separate chimney for each oven, as one chimney may be made to provide sufficient draught for the successful working of three or four ovens, while equally good results may be obtained

when the chimney is placed at some considerable distance from the ovens. The hearth of all foundry ovens should be placed on or about the level of the stove floor.

Materials.—Of course ovens are, or should be, built of firebricks or similar refractory material, and the more substantial the walls are made the more economical will be the drying produced from them. But what is more to the point as regards economy than anything else is the continuous use to which an oven should be put in the drying of moulds and cores. Ovens that are allowed to remain idle for such a

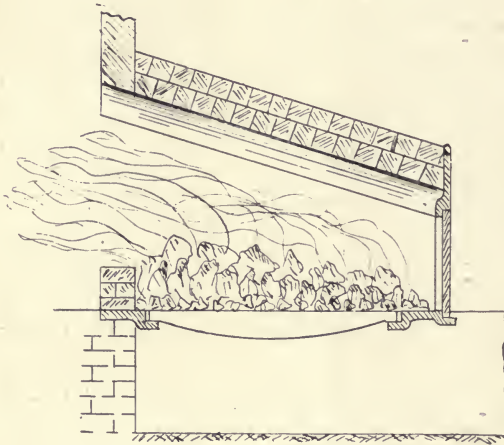

FIG. 152.

length of time as will enable all previous heat to be exhausted, and, what is worse still, to draw damp from its bottom or surroundings, retard the process of drying, thereby intensifying the additional cost which follows the drying of the contents of an oven that is only intermittently in use.

A good thick wall all round and a roof of the same capacity for retaining heat are points of economy in oven construction as essential for the saving of fuel, with its consequent saving in time and money, as the steam jacket that surrounds the steam cylinder or the "composition" covering with which the steam boiler and pipes are covered. If the ovens are to have the longest life possible, then there must be a thorough binding of their walls, with vertical stanchions and horizontal bolts right across binding these stanchions at suitable distances apart.

A good type of bearers for foundry oven roofs is found in the T section, cast according to the work they have to perform.

These girders, as shown at Fig. 153, are very suitable for carrying the roof, whether it be of cast-iron plates, or built of arch brick, as illustrated. It not infrequently happens that cast-iron plates are applied as substitutes for roofing and last for many years when exposed to heat which is not above normal temperature for drying loam cores. But even such plates, although perhaps convenient material for a foundry, may not always be the cheapest, and where heat of drying is abnormal, a brick arch, as illustrated, and well padded, is undoubtedly the only way of roofing a foundry oven satisfactorily.

Situation.—Ovens are usually placed at the ends of jobbing foundries, an arrangement which goes a great way in keeping the shop clear of undue heat, and is an advantage which adds considerably to the comfort of the men in the foundry during the excessive heat experienced in most foundries throughout

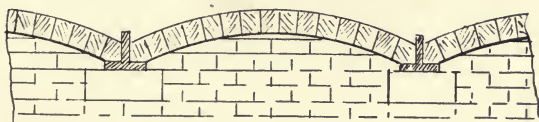

FIG. 153.

the summer months of the year. Besides this the traffic common to ovens is more conveniently out of the way at the ends of foundries than when the ovens are placed along its sides. Therefore *end-ways* for ovens in the foundry should be observed wherever possible.

One of the principal points to be observed in selecting a site is dry ground to build upon, especially with those ovens that are built outside the foundry, and if the bottom of the furnace pit or fire-hole be underneath the level of the ground on which the oven is built, nothing short of good drainage all round will suffice to keep the oven dry throughout all conditions of weather. Where this has been neglected, or has become defective through the process of time, damp floors result (sometimes actual water is to be seen), thus creating a waste of fuel too apparent for further comment.

But where firing is light and no intense heat from the oven is experienced during the day, no objection need be raised

about situation, even should such be practically in the middle of the shop, as may be seen in some of our "bank-pipe" foundries. A core oven in the centre of four "banks" employing green-sand pipe moulders, four benches for making the cores, possibly of various sizes, and two carriages for the convenience of drying the cores with all the equipment necessary, is a situation satisfactory to all concerned. All firing required for these cores being in the night time, no inconvenience from heat, as previously referred to, is possible at least to any great extent.

Firing the Oven.—It is a peculiarity of good drying that moulds and cores as a rule require to be treated separately; and for that reason cores, especially if they be of straw and loam composition, are exclusively dried in what is known as the *core oven*. Mould drying is constant, but core drying on the lines suggested is of necessity intermittent, and the firing suitable for the latter would be too slow a process for the former, while on the other hand the firing necessary for moulds in general would spell destruction for cores of the class referred to. Likewise constant heat in a core-oven is impossible, because of the frequent opening and shutting of the doors of a core-oven working under normal conditions. Such frequent opening of doors would in the case of a mould-drying stove retard drying, and such a loss of heat as this entails, altogether apart from time, would make the cost of drying moulds in the core-oven unnecessarily expensive. Hence the necessity for separate stoves where work as indicated can be found for them. Oven-firing in the foundry is always best and most economically performed when the moulds occupy all available space for drying and when the ovens are kept practically constantly under fire.

Gas-Drying Ovens.—In gas-producer ovens there are at least two systems, namely, those which are installed with gas producer and steam boiler separate, and others of a much smaller and less pretentious type, placed alongside of the ovens, generating gas and the necessary steam for combustion. The former of these systems in gas oven construction and drying has long been tested, and to many it seems the only way of drying economically; the latter is of a much

more recent date, but through the process of time may yet form a rival in gas drying on a smaller scale to the old-established installation of gas drying referred to.

The arrangement of flues in gas oven construction is part of the secret, if it may be put so, belonging to the system, and wherever it is adopted the flues must be designed to meet the peculiar needs of the branch of founding practiced. Consequently the flue arrangement of a vertical pipe gas-drying oven would not work economically if adopted to dry the work common to jobbing foundries. A good average pipe foundry oven for vertical drying must measure from rails to roof from 12 ft. to 17 ft., and sideways anywhere between 3 ft. and 5 ft. and, say, 40 ft. long, while that of a jobbing foundry may approximate 30 ft. long by 12 ft. by 10 ft. high or otherwise, according to work done. From the foregoing we see the need of thinking out the matter with those who make oven construction and drying their specialty. However, it might be pointed out in passing that the ratio between gas oven capacity and their gas producers, roughly put, works out approximately at as 1 is to 30, and between steam boiler capacity of the Cornish type for such work and the producers as 1 is to 4.

Having referred in brief to the difference of construction and economy in drying existent between gas and coal ovens in the foundry, one would do well to examine minutely the claims of each. With gas pre-eminence is only possible where large quantities for oven drying are imperative, and systematically consumed every day. But before adopting this process challenge and scrutinise the method proposed, and most especially as it relates to first cost and upkeep.

The calculations given above refer to an installation of twelve stoves, with an average capacity of 32 ft. by 10 ft. by 12 ft., and of course these must be subject to modification or alteration proportionately (and especially in steaming capacity) when a smaller installation is considered.

Ovens for drying purposes in foundries are absolutely without limitation in design and construction, and a small gas oven fired with a supply of corporation gas, burning from a simple

arrangement of jets, can be made to dry small and medium cores at a cost per hour cheaper than an oven for similar work using solid fuel of any description—*i.e.*, if the gas in question be at hand and of moderate cost.

FUELS

The question of fuels for founders and those interested, either from its commercial or practical side, is of intense importance, and in a very special degree is this the case with founders that do a large business in dry-sand and loam castings. Fuel in foundry work consists principally of coke for the cupolas, ovens, gas producers, chaffer or fire-lamps, and hot air dryers. For these purposes cokes of all grades and prices are used; the highest quality being used for melting metal, and all others are either directly or indirectly used for the drying of moulds. Coal in many foundries is used for drying purposes, especially where gas, hot air, and the newer modes of drying have not yet been brought into practice; also, where the improvising of fires for jobs in the floor, in the old-fashioned method of drying with "lump coal" of good quality, and the common grate of the oven which works unaided by force draught, are still in practice. The list of fuels that are used in the foundry also includes dross for steam raising and in some places for gas producers, oil for crucible melting, and charcoal to a limited extent for annealing.

The testing of fuels is much the same as the testing of blackings, that is to say, nothing but actual contact with the work these have to perform in practice will definitely determine their true character and value for the foundry. Therefore, it is only by observation and experience that we get to know the fuels that are most suitable for use in the foundry or elsewhere. This is most manifest in the selection of coal for grinding into coal-dust for the mixing of green-sand facing sand, a material of great importance in this division of iron founding.

Coal and coke mixed in suitable proportions are frequently used in "chaffer-drying," a practice much in evidence where "skin-drying" of green-sand work is necessary, and is of

daily or hourly practice in loam moulding, either for hurrying on the drying of "rough coating," or the drying of moulds in this foundry department, preparatory to an absolute finish by blackening, etc. Coke by itself is an unsuitable fuel in some cases for this purpose, as it burns with little or no flame owing to its deficiency in volatile combustible matter. A bituminous coal which burns with a moderate flame gives the best results for the drying of moulds by open fires. A lean or anthracitic coal which burns with an almost smokeless flame is but little better than coke for the firing of moulds in the floor without forced draught, but such a coal is usually suitable for making coal-dust.

It may also be mentioned that the greater the depth of a pit-fire below the floor level, the more necessary a flaming coal, within certain limits, becomes. These pit-fires being not infrequently in the form of miniature bonfires, the heat rises to the highest part, a distance at times considerable, and thus enables the extreme top of the mould, so situated, to be thoroughly dried. Fuels as indicated here, usually give a nice brown tinge to the mould, and where this is apparent, other things being equal, a beautifully skinned casting is as a rule a foregone conclusion.

Coke.—First, we consider this from the standpoint of cupola practice, and in this the quality of coke is one of the most important things in melting iron, because iron melted in a cupola is in constant contact with the fuel. The best coke for cupola melting must be able to sustain the burden of the charges of iron in the cupola. From 8 to 10 per cent. ash may be taken as a fair average, and it should not contain too much volatile matter as this aggravates the tendency which cupolas have for "bridging" or "bunging," an error in melting metal which means so much lost to the foundry.

With good coke sulphur should not exceed 0.50 per cent., which more or less finds its way into the castings, the best of metal thus becoming considerably affected, especially as it relates to mechanical tests both transverse and tensile. Taking the market prices of good and bad coke, it will be seen that the difference is comparatively trifling; the wonder is to

practical men how some cokes find a place in the market as cupola cokes at all. Such good luck for the coke merchants is the outcome of the inefficiency of the buyer, and his absolute want of knowledge of the points that go to make good coke for cast iron cupola melting.

From 10 to 15 per cent. in price is all that exists between good and bad coke for cupola purposes, and for this some take the cheapest, which invariably retards melting, which in turn reduces output from the cupola considerably, gives inferior running metal, and of course as a result inferior castings also. These results, with additional expense of fettling the cupola, caused by abnormal waste of time and material, not to mention unnecessary worry, merely for a paltry few shillings, condemns such practices as a penny wise and pounds foolish policy in foundry management.

Dry coke of good quality is lighter than water, therefore it is worth while noting the condition in which it is received, as it passes over the weighs, and compare this with the payments. Some make it a point to keep all cokes under cover, but a certain amount of water or moisture are necessary to give improved working in the cupola.

Good cupola cokes are dark grey in colour, very similar to a No. 4 iron, sonorous and of a semi-metallic lustre, and to the practical man sight, sound, and density are, apart from analysis, however useful and necessary this may be, the methods by which he determines good from bad. If to such experience is added the knowledge gained by the chemist in the laboratory, the working of the cupola cannot fail to be improved.

The variable density of cokes causes mischief in the cupola—unless the man in charge of it knows how to watch and work all grades according to their own peculiarities. And, as a matter of fact, the weight or measure of coke, which forms the “bed on the hearth” of the cupola may when another coke is used be altogether insufficient for the purpose intended. Doubtless the absence of this knowledge has prematurely “bunged up” cupolas by pig metal getting down in front of the tuyers, through insufficiency of density in the coke to maintain the melting zone of the cupola in its

normal position and condition throughout the various stages of the melt.

A coke for melting iron in a cupola may have a high calorific heat value, but its want of density may condemn it as a first class cupola-coke, because insufficient density gives inefficient resistance to the load of iron charges in the cupola, and, as already indicated, precipitates the iron too hurriedly down to the melting zone, thereby reducing the melting capacity of the cupola, besides producing badly melted metal for castings.

Further, fuels for cupola foundry practice have remained very much the same as when cupola and crucible were the only processes of melting metals in iron and brass foundries. One would have thought that, with the advent of the hot blast at the melting furnaces in 1828, and as patented by Mr. Neilson, and first adopted at Clyde Ironworks, near Glasgow, and the great development in output and cheapness of steel and malleable iron since Bessemer, in 1856, read before the "Cheltenham Meeting of the British Association" his wonderful paper entitled, "The Manufacture of Malleable Iron and Steel without Fuel," should have brought a change ere now.

It is thus a matter for surprise that cupola practice in the foundry, and its relation to fuels, *solid or liquid*, remains practically the same as it was prior to any of the improvements in smelting and melting referred to. But, while this is so, much has been done with regard to fuels in crucible melting, within certain limits in the finer metal castings trade. This is specially so in the melting of large quantities of the finer metals. Still, where heavy melting is not imperative, the crucible, with solid fuel in the form of coke of a medium quality and low in calorific intensity, or coal, aided by chimney draught, is, in the opinion of the writer, cheapest and best, for small melts of all metals without distinction, even to cast iron, which, by the way, many foolishly imagine cannot be melted unless on the lines of common cupola practice. The process of "liquid fuel meltings" is but, perhaps, in its infancy, and the progress made by the different methods for a number of years back has, to a considerable extent,

yet to be tested. It should be noted that, so far, any substitute for crucible furnace melting on the old lines has got to be done by the aid of a blast. But whether it be what is known as the "Brass Melting Air Furnace" or those types of furnaces burning "oil or gas," as, for example, the "Charlier Furnace," in both cases the saving to a very great extent, if not altogether in the cost of crucibles, is a foregone conclusion.

The air furnace for heavy brass casting, where the metal is tapped like an ordinary foundry cupola, as is the case with "Meyer's Patent Brass Melting Air Furnace," is very commendable for heavy work, and is a great improvement on melting with, say, eight or ten 300 lb. crucibles for a heavy brass job, and pouring their contents into a suitable foundry ladle to cast the job intended: a practice not uncommon before air furnaces for melting brass were introduced, and may even in some cases be seen at the present day.

Non-Cupola Coke Fuels.—The cokes which come under this title, include those used for the drying of moulds, and the manufacture of "producer gas" in the foundry, and for "hot air drying by portable fires"; all of which, from the common "slack" or cinder, to the superior anthracite coke are, however serviceable in the foundry, but the by-products of the gas works. The former of these so-called cokes is of little account when used by itself, but the calorific power of the latter being so much greater than the former makes it much sought after by the founder, for drying with the portable hot-air dryer, a method of drying which does away to a very great extent with smoke and the obnoxious gases in floor drying, a thing so detrimental to the health of the foundry workers. This, apart from the economical side of the question, where there is room and work for its adoption, will undoubtedly make the "hot air dryer" supersede all other antiquated methods of drying in the floor when such is necessary.

In the use of these cokes in the foundry there is an inclination to expect too much, and in that way chaffer firing is retarded. The best of them ought to be assisted by a little live coal for this purpose, and so facilitate combustion,

which in turn gives improved results in drying, with a consequent saving of time also. Of course the slowness with which these cokes (when normal) burn in the fires in question is entirely due to the want of blast or reinforced draught of some kind or other. Cokes of this class must have some sort of forced draught, otherwise their use for drying purposes in the foundry is not commendable.

It is evident then that forced draught of some kind or other must be considered where hot-air drying as a system is to be adopted, and for this purpose a blast pipe arrangement for the foundry becomes indispensable to an extent proportional to the wants of business anticipated in this direction. However, this need not be taken too seriously. For instance, under certain circumstances a small pipe direct from the steam boiler, applied to the hot-air dryer, will give equal satisfaction, in so far as the working of a "hot-air dryer" is concerned. And with this method of blowing, if superheated steam be applied, and coke of normal quality be used, results will thereby be proportionately greater. However, steam from 30 lbs. to 40 lbs. pressure may do all that is required, and by this method of blowing the coke, fire engine and fan are at least dispensed with.

FOUNDRY TOOLS

In the matter of tools as distinguished from plant there is, perhaps, but little to say in so far as the tools of a jobbing foundry are concerned. Consequently the question becomes focussed within somewhat meagre limits, *i.e.*, if we except the hundred-and-one nick-nacks that are known as tools to moulders, although these with rammers, riddles, barrows, shovels, and coke baskets, etc., etc., in goodly supply, are all items to be considered in furnishing tools for the foundry. Further, there are tools for the cupola, sling-chains and hooks of various types (as will be seen further on as crane furnishings) for the lifting and laying of the variety of loads known to founding in all its branches. These, if we include pneumatic tools and portable hot-air drying fires, can only be touched upon briefly as we proceed.

Shovels.—In this connection it may be said to profit that one of the first things a sand moulder should have is a good shovel. Give a man a shovel he can call his own, at least while he is in any given employment, as by doing so he thus takes an interest in keeping it in good order, and thereby the lengthiest possible existence of the shovel is guaranteed, and the owner for the time being will do more for his money than is possible where this habit is not practised. Nothing wastes a shovel so much as its being badly kept, and what is everybody's business in this matter is, to use a hackneyed phrase, nobody's business. Therefore, if the shovels provided for moulders in a foundry be not distributed on the lines suggested, but scattered here and there, as it were, on the foundry floor,

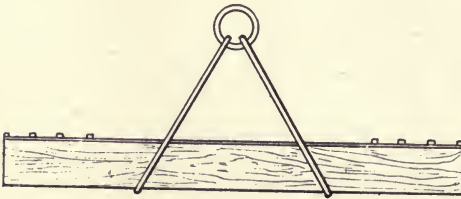

FIG. 154.



FIG. 155.

the property of all alike, cleaning, trimming, and otherwise oiling, at the end of the week, of such shovels will undoubtedly be utterly unknown, and as a result deterioration and its consequent loss to the employer will inevitably follow. This loss is intensified by unnecessary exertion on the part of the employee, the minimum of work being done by the maximum of physical effort. To those who have never counted the cost, the foregoing may appear a small matter; nevertheless, it is one of those factors of waste, or leakage, often too lightly passed over, and a foundry badly equipped with this simple tool means money wasted in every phase of founding; indeed, this leakage is to be found in some of the shops where one would least of all expect to find it. One of the most painful things for a foreman to endure is to see,

it may be, two or three men waiting their turn for a shovel or some such tool throughout the process of moulding his job.

A penny wise and pound foolish management is in part, as a rule, embodied in an inferiority and scarcity of tools, and as the shovel has been taken as an example, one can only add that the shovel or spade which cannot cut clean in digging and thereafter discharge its contents easily, should be attended to and put right, in a similar way to the machine that is failing to keep up its output through lack of repairs. What applies to the shovel in this respect applies to all tools alike in the foundry, and were more attention paid to those seeming trifles as they here and there exist, more satisfactory results would undoubtedly follow. Indifference as to condition and supplies of the minor tools, not to mention aught else, means money wasted which otherwise could be saved.



FIG. 156.

Beams.—The beam for turning moulding boxes, as illustrated at Fig. 154, and which could be illustrated in many forms and sections (were it not that brevity forbids it) is a common tool of long standing in specialty or jobbing shops. The beam links and stirrups which constitute the beam as a whole are illustrated in Figs. 154, 155 and 156. Of course, other designs with a more costly equipment might easily be given. Suffice it to say this type, for economy and handiness for such jobs as tank plates and things common in jobbing work, is not likely to be excelled. These beams, light or heavy, where good practice is attended to, are all made from hard wood, and mounted or trimmed, in some cases, elaborately. All the same, a handy jobbing moulder is not often at a loss for a tool of this kind, because if he cannot get one of wood then his next shift may be some sort of a beam in malleable iron, but if beaten here also, he will fall back on the inevitable, namely, cast iron, and cast one somewhat similar in section to Fig. 158, *B*, which in all probability would serve his purpose very well, especially if it were a case of lifting some check or cope from 10 to 15 tons' weight, and also act

as a valuable weight and binder for weighting or binding a cope or top part. However, take Fig. 154 as a pattern in this respect, and, of course, of any section desirable, then by substituting a strong sling chain for the links, as seen at Fig. 154, a very good beam is formed for heavy lifts in the class of work suggested. Hence, with **S** and **C** hooks and ropes, or perhaps chains—although chains are not so handy as ropes here—one can lift comparatively easily in this way any load within the strength limits of the beam and lifting capacity of any given crane that may be employed for such work.



FIG. 157.

Such are the stratagems in jobbing moulding that the term tool is really ambiguous to a degree, and is doubtless without limit in its application. This is borne out by the many devices the moulder has to resort to in his everyday work, so to speak, in the foundry. In short, a jobbing moulder, to be successful, must be a man of many shifts, as he has frequently to make tools in jobbing practice out of what, to the uninitiated, may appear at times to be nothing more than a heap of dumped cast-iron scrap, or perhaps malleable and cast iron, as the case may be.

Clamps, Ringers, Binders and Stools.—The uses to which this quartette of tools are applied must be considered collectively, because where we find the one tool, we usually find all of them in some form or other doing their share of the work at the binding of some cylinder, condenser, bottom, or such castings as require abnormal strength of binding to secure the mould and cores at the time of pouring.

While the foregoing is the prime duty for which these tools are made, their usefulness for other purposes in many foundries cannot be overestimated, but need not be further referred to at present.

Clamps.—Figure 157 represents a common type of cast-iron clamp usually employed for the clamping of boxes or copes previous to casting. These tools are made to many dimensions, particularly in length and section, and may weigh anywhere in pounds from 5 to 500; and when such weight as the latter is necessary, the eye *A*, as seen at Fig. 157, is very

serviceable for slinging purposes and thereby binding them comparatively easily in their places on their respective jobs. The grasp, or distance between the toes of these clamps, may be anywhere from 3 ins. to 6 ft. or 8 ft. as required. Some resort to malleable iron, about 2 ins. square, for the making of these clamps when beyond the smaller dimensions. Still, experience in both types has declared cast-iron clamps, as illustrated at Fig. 157, to be by far the safest, cheapest and best for work that usually goes by the name of "pit moulding," *i.e.*, where binders and ringers are not adaptable or perhaps procurable.

Ringers and Binders. — In Fig. 158 there is shown a sectional elevation of ringer and binder, which is given in this form for convenience of space. Also, these are both shown in section as they appear together at the binding of any job that is about to be cast where this sort of moulding is in operation. *A*, in Fig. 158, is the ringer, and *B* of the same figure is the binder; these ringers

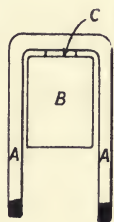

FIG. 158.

are, as a rule, made from malleable iron of, say, from 1 in. to 2 ins. square, and are used for many other purposes in the foundry besides binding; and, of course, the binders are all made from cast iron, and vary in section and design according to the needs or wants of the foundry. *C* is a small oblong piece of iron, preferably malleable, and is placed, as shown at Fig. 158, between binder and ringer for the purpose of bedding both to each other the better, as also the safer and more solid driving of the wedges during the process of binding any job preparatory to casting it. Obviously the foregoing on "binding" clearly indicates the use of wedges in this division of moulding. But while this is so, it must be borne in mind that for a similar purpose, namely, the holding down of copes and such like as previously suggested, bolts are used in specialty work and where, as a rule, no ringers are employed. The binders in such cases have special oblong holes cast in them for bolts passing right down through binder and casing flanges or otherwise, and by this simple device the job is bound by the tightening of the bolts with their respective nuts. This is a practice common to

marine cylinder work, which does away with the use of clamps and ringers altogether; and, wherever in operation, facilitates the making ready of a job for casting.

Further, where average spherical pit work or such-like is cast, the ringers, as illustrated by *A*, Fig. 158, for safety and handiness of working, should be made to lengths, thus: 10 ft., 6 ft. and 2 ft. Six to each of these lengths, with stools as seen at Fig. 159, may be regarded as a foundry pit's tools for binding any job capable of being cast in it.

It is a good feature with short ringers to have them made with a crook at one of the ends instead of being square at both ends, as by this means extensions are easily made by simply hooking the crooked end through the end of the square ringer and thereby getting the desired extension—a convenience often required at pit casting.



FIG. 159.

Stools.—Three favourite lengths to this design are given as follows: 24 ins., 18 ins., 12 ins. and 6 ins. (see Fig. 159). All these different lengths may be made from the one full length of pattern by shifting the top, *B*, inwards to the lengths stated. Thus is summarised the four principal tools used in the binding of pit work in a foundry.

Having previously referred to *C* and *S* hooks, these with, crane-sling chains, Figs. 160 and 161, embrace all that as a rule is classified as crane furnishings. Each of these has an individuality its own, and to take each in detail and stipulate its special duty in the foundry would take more time and space than we have at our command. The following, however, may be said: *C* hooks and *S* hooks are made from $\frac{1}{4}$ -in. up to 2 in. round iron or even more, the latter being pointed or formed at one of the ends as well as lengthened to suit the peculiarity of the work for which these *S* hooks are designed and made. The *C* hook is best suited for heavy work and when slinging with a chain it is very handy for passing through the "loop" or "bow" of the chain as it appears when doubled up at medium and heavy lifts. Also this hook for similar work is most serviceable for lengthening sling-chains where shortness is a difficulty, and

where the sling-gabs of same are at times unfavourable for catching up what may be comparatively easy for the hooks in question.

Figure 160 is a screw hook, and when these are attached to each end of a "triple sling chain," prove themselves to be very handy tools wherever exact level slinging is imperative. In point of fact, where "the sling of three" is in practice, as we often find it to be the case with cores, a sling chain of this kind is absolutely necessary—that is to say, if method and economy is of any importance at all. Where the triple-sling chain as suggested cannot be profitably employed, a single screw hook, as seen at Fig. 160, for general lifting purposes will prove a very handy and profitable tool in most jobbing foundries.

Fig. 161 illustrates what is known as a "double hook," and the top crook *A* which lies at right angles to the right and left section of this hook makes it an indispensable tool in foundries that have two or more cranes (especially derrick) in the foundry. But whether this be the case or not, it is a very handy tool, apart from its uses in shifting from derrick to derrick the miscellaneous loads in the everyday work of a foundry wherever the "traverser" is not yet in operation.

Pneumatic Tools.—Tools of this description are gaining much prominence in foundry practice, and to some are the acme of perfection in this sort of foundry equipment and that of the fettling shop as well. But it is with this, the latest improvement in tools, as it has been with the moulding machine—which, by the way, is no new invention—that is, failure has in some cases followed the adoption of pneumatic appliances, because of misapplication and the ignorance of the buyer, or perhaps by what is called the good business capabilities of the patentee of such tools or his representative in business.

In this connection, it may be permissible to say, that more

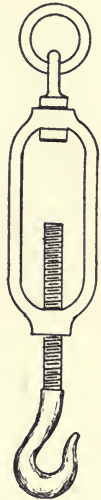

FIG. 160.

than thirty years ago the writer saw moulding machines scrapped that had been doing duty every working day for a number of years previously. These machines not having given the satisfaction anticipated, their owners returned to the old stereotyped method by bedding down the class of work referred to in the floor, *not turning over with bottom and top flasks as most moulders would imagine*, and are continuing to do so up to date, and at a cost considerably less per casting than was possible with the machines in question. And just one other case in point, one of the largest foundries

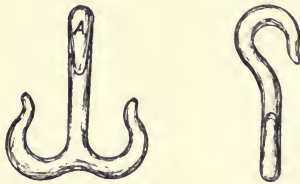

FIG. 161.

in the United Kingdom equipped a certain class of work with tools, plant and patterns of the latest type in hydraulic machine moulding, at a cost of many thousands of pounds, and after working this plant for all it was worth for a considerable time, this firm also had ultimately to consign

this costly and special hydraulic machine plant to the scrap heap.

These, as stated, from actual experience are enough to shatter the belief even of many who hold strong convictions in the utility of mechanical appliances and their adaptation to foundry practice, whether these be manipulated by wind, water, steam or electricity.

The one grand question to decide with these tools is their suitability, whether it be with moulding machines or pneumatic foundry tools of any description at all. Nevertheless these tools and machines have their place in the foundry and can be applied to much profit when judiciously thought out and adapted to a field of work absolutely suitable. To make sure of this, one must listen attentively to what is being said about any particular tool or machine, and if what has been said applies to one's work, and is confirmed by experience, then to such an extent the safety in adopting machine or pneumatic tools of any kind becomes comparatively secured. Of course it takes much experience to decide such matters, and if this be wanting, losses in such purchases

to a greater or lesser extent will more than likely follow, and the prejudice, too common amongst many, for an improved foundry practice become intensified through such failures as herein suggested.

Pneumatic tools in the foundry are now almost too numerous to mention, and whether it be for actual foundry practice or fettling, the wants of either are now largely catered for by foundry furnishers of every description. In the foundry there are nowadays pneumatic ramming, riddling, sifting, and blowing of moulds. Also, for "blazing" during the process of skin-drying moulds, and even for the drilling of holes in flasks in different parts of the foundry, the pneumatic drill tool is to be found doing such work profitably in some of the up-to-date foundries in the country.

A great saving is claimed in the fettling shops since the introduction of the pneumatic hammer and sand-blast process of cleaning castings, which is said to give an improved skin for painting or otherwise. These do not exhaust all that pneumatic application can do in the foundry, but it is doubtful whether the use of them for such work as "chilling metal for specific purposes" is advisable. Here follows a quotation from an up-to-date journal loud in the praise of pneumatic tools for the foundry:—"In some classes of long slender castings, such as piping, where the cores are built round a thin tubing, and, as is sometimes specified, chaplets have to be sparingly used, the cooling effect of a current of compressed air will be found a very useful and convenient expedient to use to prevent the core being lifted in the middle by molten metal." The above appears to the author to be entirely opposed to sound practice.

Gas and Hot-Air Driers.—For a goodly number of years the drying of moulds, particularly of the larger class, outside the ovens or stoves of the foundry has been done by gas, and by what is known as the *hot-air process of drying*. The first of these processes, in which what is known as the Bunsen burner is largely used, is a process of drying suitable either for horizontal or vertical moulded work, but preferably the latter; and in point of fact, this process is mostly employed in ingot-mould casting and vertical pit-pipe moulding. But

for drying moulds in the floor, the "portable hot-air drier" that is usually fired with gas coke is by far the handiest and most popular system of drying moulds outside the foundry oven, whether in loam or dry-sand practice.

However, it may be questioned whether hot-air driers of any kind can be regarded as tools, although these are of a portable construction, and are moved about for duty in the drying of moulds in the floor as referred to. Suffice it to say, these rank as of first-rate importance, where floor drying is an absolute necessity. Therefore, whether the *portable hot-air drier* be considered foundry equipment or a tool, such is really immaterial; but as an adjunct in this division of founding, and by its serviceableness in the drying of loam and dry-sand moulds in the floor, its adoption is more and more manifesting itself to the advantage of all concerned in the foundries doing heavy and medium loam and dry-sand castings.

The many types of *hot-air driers* in the market in these days are largely, if not altogether, confined to the class that are blown by air in some form or other. This is all the more surprising when, as a matter of fact, and as previously stated, steam can be applied with equal usefulness for the same purpose, thus doing away with the service of the engine and fan which are absolutely necessary for blowing the hot-air drier. A small steam jet applied in a somewhat similar way to the one that admits the air for the blast pipe fitted up in the foundry for those hot-air driers will do the work of blowing. Also, the steam pressure need not be above 40 lbs. on the square inch, but the higher the pressure the better the blow, and the jet for admitting the steam to the fire should not be of greater diameter than is required for a needle to pass through it.

The popularity of this system of drying is evidence of its superiority over the old-fashioned way of drying floor work by coal which was usually of a superior quality, and with improvised fires or chaffers as the case may be; and the waste of coal and coke (the latter not so frequently used as the former) when compared with the modern hot-air process of drying is all too well known to experience to admit of further comment, *i.e.*, wherever consecutive floor drying is necessary.

Apart from the commercial side of the question of drying in the floor, (and as previously mentioned) the hot-air process has on the grounds of improved conditions for all who work in the foundry much to commend it, as by this system a purer atmosphere than was possible in the old system of drying is in a measure guaranteed. This, if nothing more, is quite enough in itself to make it commendable. It is a fact that by far the greatest proportion of moulders or foundry workers on inside duty are prematurely affected by chest troubles through the density of smoke common to such foundries where coal drying consecutively in the floor by the old system is practised.

Although by this new process of drying we do not maintain that the smoke nuisance in the foundries with the class of work suggested is entirely got rid of, still at the same time the very considerable reduction in the amount of smoke improves the working conditions in similar proportion. Obviously, illustrations of any particular type cannot be judiciously given, but with the hot-air driers as with other tools, individual circumstances will dictate individual wants, and the foundry furnisher will best supply the rest.

As a matter of fact all hot-air driers are much the same in practice, but a good type is designed with air-regulating chamber, fire-box, and hot-air chamber. Besides what has been stated, the air supply may be attended to by a small blower and motor, and, if desired, can be directly connected to the drier.

Perhaps the best and most economical way of working these "driers" is to install a line of 5-in. air piping along the walls of those foundries doing much floor drying, and with suitable branches to attach the blast pipe to the portable air driers, as the exigencies of the everyday work of the foundry demands. For blowing these driers, which are best fired when using good gasworks coke, air at an approximate pressure of 2 or 3 ozs. to the square inch should be ample.

INDEX

- AGRICULTURAL castings, metal for, 76
- Aluminium alloys, 228
brass and bronze, 229
bronze, 215
charging the crucible for, 225
demand for, 229
gating of, 224
malleability of, 229
melting of, 224
moulding, sand suitable for, 223
price and specific gravity of, 228
specific gravity of, and scabbing, 222
temperature for, 226
unalloyed, 225
- Analysis, chemical, of English and Scotch pig irons, 235—240
- Analysis, chemical, of moulding sands, 14
- Annealing chilled wheels, 156
malleable cast iron, 232
- BANK pipe core boxes, 249
pipe patterns, 248
pipes, cores for, 148
- Beans for foundry use, 281
- Bell-mouthed pipes, 97
- Bend pipes, 99
- Binders, 282
- Black-sand, 20
- Blistering of cylinder castings, 119
- Blowholes and shrinkholes, 30
- Bogey-wheels, design of chills for, 154
- Boiling points of metals, 246
- Boss patterns, air vessel, 92
- Bottle-neck pipes, 96
- Bottom of moulds, pressure on, 58
- Boxes, 6
- Branch pipes, 98
- Brass castings, cooling, 214
“draw” in, 210
moulding, 208
position of casting, 211
foundry, cellar or ashpit for a, 206
furnaces, 204
temperature of casting, 209
wastage in melting, 209
- Bronze, aluminium, 215
and brass aluminium, 229
phosphor, 215
plug gating of, 216
- “Burning” cold castings, 33
heating castings preparatory to, 34
- CAMBER and uniformity of cooling castings, 51
- Casings, pipe factory, 163
- Casting facedown, 24
position of, dry-sand cylinders, 122
job pump pipes, 106
- Castings, sandless, 156
- Chaplets, creosoted, 44
on polished and unpolished parts, 42
tinned, 43
- Chilled cast-iron wheels, 154

- Chilled wheels, annealing of, 156
 Chills for bogey wheels, design of, 154, 156
 metal most suitable for, 155
C-hooks, 284
 Clamps, ringers, binders and stools, 282
 Coal dust, 19
 for facing sand, 19
 Cokes for foundry uses, 275
 good cupola, 276
 Colour as the indicator of temperature, 79
 Compressed gas sustaining a mould at the time of pouring, 41
 Condenser patterns, 251, 252
 Cooling brass castings, 214
 Core boxes, bank pipe, 249
 gum, for cores, 28
 Core-irons and cores for pipes, 100
 making for dry-sand cylinders, 119
 pump-pipe, 105
 sand, medium, 137
 Core sands, core-irons, and cores, 132
 sands for large medium and small cores, 136
 Cores for bank pipes, 148
 for green-sand pipes, 147, 148
 gas-engine cylinder jacket, 131
 green-sand, for pipes, 147
 gum water for, 28
 jacket cylinder, for petrol engine work, 133
 jacket, for loam cylinder moulds, 127
 method of placing, in S.V. cylinder mould, 185
 placing Corliss cylinder, in dry-sand moulds, 145
 sand for small, 138
 sand jacket, 126
 screw hooks for slinging, etc., 285
 steam cylinder jacket, 126
 Cores, vertical dry-sand pipe, 150
 vertical loam pipe, 149
 Corliss cylinders, casting, three core method, 140
 Corliss cylinders, casting, five core method, 142
 Corliss cylinders, casting, seven core method, 143
 Cotter cores cast in rams, 85
 Cranes, 6
 Cupola and melting, 10
 charging the, for cylinders in a jobbing shop, 73
 cokes, 276
 for melting malleable cast, 230
 Cylinder castings, blistering of, 119
 cover castings, defects on, 86
 moulds, finishing dry-sand, -117
 in dry-sand, ramming, 116
 Cylinders and engine parts, metal for, 74
 in dry-sand, venting, 116
DAMP floors, 200
 Design, tank plate, 49
 Diagonal bars and shrinkage, 48
 "Draw" in brass castings, 210
 speculum metal, 218
 Drying an air vessel core, 95
 gas and hot air, 287
 ovens, gas, 272
 Dry-sand, 15
 and dry ashes in loam moulding, 200
 cylinder moulds, closing, 120
 finishing, 117
 cylinders, core making for, 119
 position of casting, 122
 facing sand, 21
 gating cylinders in, 124
 moulds, temperature of metal for, 82

- Dry-sand, venting cylinders in, 116
- EQUALITY of metal, 50
- Examples of feeding, 66, 67
- FACING sand, dry-sand, 21
 for gear wheels,
 green-sand, 19
 green-sand light, 16
 heavy and medium,
 16
 milling of green-sand,
 18
- Feeding automatically by hot metal
 only, 70, 71
 by one rod only, 68
 decentralised, 67
 open-sand castings, 70, 71
 or compressing open-sand
 castings, 69, 219
- Finishing dry-sand cylinder moulds,
 117
- Flasks, their use in loam moulding,
 195, 196
- Foundry floor, the, 5
 oven construction, 269
 firing the, 272
 gas drying, 272
 materials of con-
 struction, 270
 situation, 271
- Fuel for chaffer and hot-air drying,
 274
- GAS and hot-air drying, 287
 drying in foundry ovens, 272
 engine castings, core irons and
 core sands for, 132
 cylinder jacket cores,
 131
- Gates and shrinkage, 165
- Gating aluminium, 224
 cylinders in dry-sand, 124
 pipe moulds, 102
- Graphite in pig iron, 242
- Green-sand cores for pipes, 147
 facing sand for gear
 wheels, 19
 light, 16
 heavy and medium,
 16
 milled, 18
 pipes, core irons for,
 148
- Grey metal and steel mixture
 castings, 77
- Gum water and plumbago wash, 28
- HEAVY projections or inequality of
 metals, 53
- Hooks for slinging cores, &c.,
 screw, 285
 C, S, and double, 284
- Hot-air drying, fuel for, 274
- Hot metal, feeding by application
 of, 70
- INCREASING breadth or depth of
 capped spur wheels, 267
- Increasing breadth or depth of non-
 capped spur wheels, 264
- Iron patterns, 247
- JACKET core, number of tubes in a,
 129
 cores for loam cylinder
 moulds, 127
 sand, 126
 steam cylinder, 126
 cylinder cores for petrol
 engine work, 331
- LOAM board, setting a, 181
 moulding and shrinkage, 55
 dry-sand and dry
 ashes in, 200, 201
 pattern pieces for
 pistons in, 192

- Loam moulding, use of flasks in,
195, 196
pipe cores, vertical, 149
piston core materials, 193
special pipes in, 259
working from a drawing in,
182
- Longitudinal section of branch
stucco pattern, 254
- MALLEABLE cast; melting, 231
iron, annealing, 232
- Manganese in pig metal, 241
- Medium core-sand, 137
large and small cores,
core-sands for, 136
- Melting aluminium, 224
and pouring speculum
metal, 220
points, 246
- Metal for agricultural castings,
76
chills, 154
mixing, 245
- Metals and their relative value to
each other, the finer, 228
- Mixing iron for jobbing foundry,
72
- Mottled pig irons, 244
- Mould conditions and temperature
for pouring metals into moulds,
82
- Moulders' shovels, 280
- Moulding an S pipe, 89
brass castings, 208
sand, chemical analysis
of, 14
taper pipe, 96
tub, 9
- Moulds, pressure on bottom of,
58
sides of, 58
- OPEN-sand castings, feeding and
compressing, 69, 219
feeding, 69, 70
- Oven, construction of foundry, 269
firing the foundry, 272
materials of construction
for foundry, 270
situation of, 271
- PAINTING of patterns for foundry,
26
- Pattern, longitudinal section of
branch stucco, 254
- Pattern making, stucco faucet, 257
stucco, for special
pipe moulding,
254
principles of, 246
special loam pipe,
259, 260
pieces for pistons in loam
moulding, 192
- Patterns, condenser, 251, 252
- Petrol engine work, jacket cylinder
cores in, 133
- Phosphor bronze, 215
- Phosphorus in pig iron, 241
- Pig iron brands and their composi-
tion, 234
graphite in, 242
manganese in, 241
phosphorus in, 241
remelting, 243
silicon in, 240
sulphur in, 241
transverse and tensile
tests of, 245
- Pig irons, analysis of English and
Scotch brands, 235—240
- Pipe, core boxes for bank, 249
cores, vertical dry-sand, 150
vertical loam, 149
factory casings, 163
moulding an S, 89
taper, 96
patterns, bank, 248
- Pipes, bell-mouthed, 97
bend, 99
bottle-neck, 96
branch, 98

- Pipes, core irons and cores for, 100
 core irons for green-sand, 148
 green-sand cores for, 147
 pump, 103
 special bends (**U** and **S**), 88
- Pit bogey wheel patterns, 250
- Pneumatic tools in the foundry, 285
- Position of casting, 106
 brass castings, 211
 dry-sand cylinders, 122
- Pouring metal into moulds, mould conditions and temperature for, 82
 speculum metal, 220
- Pressure due to fluid metal in gates, 60
 on bottom of moulds, 58
 on floating and submerged bodies, 59
 on sides of moulds, 58
- Pump pipe core making, 105
- Pump pipes, 103
- RAMMING** cylinder moulds in dry-sand, 116
- Rams, cotter cores cast in, 85
- Remelting pig iron, 243
- Ringers, 282
- Riser gates and flowers, 167
- Risers on highest parts of moulds, 39
- Risers, open or shut, 40
- SAND**, black, 20
 chemical analysis of, 14
 coal-dust for facing, 19
 dry-sand facing, 21
 for large medium and small cores, 136
- Sand, for small cores, 138
 green-sand facing—for gear wheels, 19
 green-sand facing light, 16
 heavy and medium, 16
 milled, 18
 jacket cores, 126
 medium cores, 137
 physical properties of, 23
 suitable for aluminium moulding, 223
- Sandless castings, 156
- Shovels, moulders', 280
- Shrinkage and gates, 165
 diagonal bars and, 48
 loam moulding and, 55
 or draw in brass castings, 210
 vertical, 56
 volume changes due to, 45
 warping and twisting due to, 46
- Shrinkholes, 30
- Silicon in pig iron, 240
- Site for foundry, 2
- Snap flask moulding, 115
- Speculum metal, 217
 "draw" in, 218
 melting and pouring, 220
 treatment of castings, 219
- Spur wheels, increasing breadth or depth of capped, 267
- Spur wheels, increasing breadth or depth of non-capped, 264
- Spur wheels, reducing breadth or depth of capped, 266
- Spur wheels, reducing breadth or depth of non-capped, 263
- Steam cylinder jacket cores, 126
- Steel ingots, feeding of, 70
 mixture castings, 77
- Stools, 284
- Stucco faucet pattern making, 257
 mixing, 258

- Stucco pattern, longitudinal section of branch, 254
pattern-making for special pipe moulding, 254
- Sulphur in pig iron, 241
- TANK plate design, 49
Taper pipe moulding, 96
Tub moulding, 9
- VENTING cylinders in dry-sand, 116
of top parts, 37
- Vertical dry-sand pipe cores, 150
loam pipe cores, 149
shrinkage, 56
- WASTAGE in melting brass, 207
White pig iron, 243



