

T 359  
.S62  
1912  
Copy 1



Class T 359

Book .862

Copyright N<sup>o</sup> 1902

**COPYRIGHT DEPOSIT.**





NOTES ON  
Technical Sketching and Free Hand Lettering  
FOR ENGINEERING STUDENTS

BY

ALTON L. SMITH, M. S.  
Professor of Machine Design  
Worcester Polytechnic Institute



PUBLISHED BY THE AUTHOR  
WORCESTER, MASS.  
1912

T 359

S 62

1912

Copyright, 1912  
By ALTON L. SMITH, M. S.  
Worcester, Mass.

761.75

© Cl. A 320631

Printed by  
THE DAVIS PRESS  
Worcester, Mass.

## PREFACE

The modern engineer must know how to make drawings in order to know how to read them. However, very little of his time is spent at the drafting board. His drawings consist mainly of sketches showing his ideas in more or less detail and which are turned over to subordinates to be worked out and put in the conventional form. In the solution of his construction problems, he is obliged to keep in mind all three dimensions of materials and a preliminary sketch stands in the place of a model which he can work over and examine in order to clarify and fix his ideas. Such sketches must often be made in great profusion and dexterity with the pencil is frequently an inspiration to the brain.

One of the primary functions of a course in drawing is to cultivate and extend the faculty of mentally picturing unseen forms. In acquiring this faculty, the draftsman must be able to express his ideas quickly and accurately through the medium of drawings. He must also learn to read correctly the ideas of other engineers as expressed in drawings.

The actual construction of an object from the drawing representing it is a crucial test of ability to read that drawing. There are many disadvantages of such a test applied for that purpose alone and it is believed that the translation from a projection drawing of the object to an axometric or isometric representation meets all the requirements of the case with far less expenditure of time. The reverse process also gives a most valuable training and the author believes, after long experience in this work, that the methods herein presented secure the best results with the least effort.

Though devoted primarily to the teaching of drawing, the illustrations and problems have been selected so as to give the student familiarity with a wide range of modern manufacturing and engineering practice. A considerable amount of matter has been added for this third edition and the author wishes to thank the many friends who have provided material or given suggestions.

Worcester, July 20, 1912.

A. L. S.

# CONTENTS

	CHAPTER I.	PAGE
Description of Methods of Representation . . . . .		7
	CHAPTER II.	
Shop Drawings and Blue Printing . . . . .		16
	CHAPTER III.	
Miscellaneous Details of Construction . . . . .		34
	CHAPTER IV.	
Toothed Gearing . . . . .		47
	CHAPTER V.	
Structural Drawing . . . . .		57
	CHAPTER VI.	
General Suggestions on Technical Sketching . . . . .		70
	CHAPTER VII.	
Sketches for Shop Drawings and Electrical Symbols . . . . .		76
	CHAPTER VIII.	
Geometric Perspective and Artists' Perspective . . . . .		85



	CHAPTER IX.	PAGE
Axometric Sketching . . . . .		92
	CHAPTER X.	
Isometric Drawings and Cabinet Projections . . . . .		106
	CHAPTER XI.	
Comparison of Methods of Representation . . . . .		109
	CHAPTER XII.	
Shade Lines and Line Shading . . . . .		111
	CHAPTER XIII.	
Free Hand Lettering . . . . .		116
TABLES . . . . .		134
INDEX . . . . .		155

## TABLES

	PAGE
TABLE 1.—Decimal Equivalents of Common Fractions. Whitney or Woodruff Keys. U. S. Standard Bolts and Nuts . . . . .	134
TABLE 2.—Hexagon and Square Head Cap Screws. Set Screws . . . . .	135
TABLE 3.—Fillister Head Cap Screws. Button and Countersunk Head Cap Screws . . . . .	136
TABLE 4.—Collar Screws. Studs. A. L. A. M. Standard. Bolts and Nuts . . . . .	137
TABLE 5.—Machine Screws, A. S. M. E. Standard Machine and Wood Screw Gage. Twist Drill and Steel Wire Gage . . . . .	138
TABLE 6.—Heads of Gib Head Keys. Lengths of Plain and Gib Head Keys . . . . .	139
TABLE 7.—Square Feather Keys. Straight Flat Keys. Machine Knobs. Wing Nuts . . . . .	140
TABLE 8.—Machine Hand Wheels . . . . .	141
TABLE 9.—Ball Machine Handles. Standard Punched Washers . . . . .	142
TABLE 10.—Cast Washers. Spring Cotters. T Slots. Eye Bolts . . . . .	143
TABLE 11.—Properties of Wrought Iron Pipe . . . . .	144
TABLE 12.—Fittings for Pipe Railings . . . . .	145
TABLE 13.—Standard Tapers . . . . .	146
TABLE 14.—Gage Lines. Rivet Spacing. Rivet Dimensions. Clearances . . . . .	147
TABLE 15.—Jaw Clutch Couplings 1. Jaw Clutch Couplings 2 . . . . .	148
TABLE 16.—Flange Couplings . . . . .	149
TABLE 17.—Compression Couplings. Solid Journal Boxes . . . . .	150
TABLE 18.—Rigid Pillow Blocks. Plain Shaft Collars . . . . .	151
TABLE 19.—Angle Pillow Blocks. Safety Shaft Collars . . . . .	152
TABLE 20.—Pulley Proportions. Spur Gear Proportions . . . . .	153
TABLE 21.—Weight of Material . . . . .	154

## CHAPTER I

### DESCRIPTION OF METHODS OF REPRESENTATION

1. Probably the best way to describe a material thing is to make a picture of it, and a written language composed of hieroglyphs would prove satisfactory if it had to express only what we sense through the eyes. To depict odors, sounds or emotions would severely tax such a language as reference to the ancient Egyptian monuments will prove.

The written language of modern engineering construction has to deal chiefly with shape and size of material things. It is a picture language and its superiority over the language in common use will be quickly recognized, if one attempts to read a written description of a modern machine without the aid of an illustrative drawing.

A perusal of legal documents will show how difficult it is to express an idea or fact concisely and with exactness. In the modern sciences, extended terminologies permit this. There is, of course, a special vocabulary of technical terms used by engineers and shop workmen, and it would be possible to write a specification describing each part of a machine so it could be built, but to write and to read such a description would be a tedious and a costly process involving many chances for error. There was a time when construction was carried on in shops by oral directions from the foreman, or the workman made a part of a machine to suit his own notions, very much as some repair work is now done. If such methods had prevailed, the general use of our numerous modern contrivances would have been deferred to the remote future.

2. An engineering drawing must describe the machine or structure completely, exactly and concisely that it may insure economy of time for the maker and the reader. Most drawings used in engineering work are made mechanically with instruments, because most of them can be thus made more economically. There are, however, many drawings which an engineer or draftsman has to make, where it would be very impracticable to make them with instruments. Such are the innumerable preliminary

sketches used in designing, the incidental sketches made for illustrative or explanatory purposes, sketches of parts of existing machines and sketches for work of which no record is preserved such as repair jobs. It is also true that some desirable forms of representation which can be made well and quickly free-hand, become expensive when drawn with instruments.

3. The problem in illustrative drawing is to produce a representation of an object having three dimensions on a flat surface having only two dimensions. The difficulty lies in properly representing the third dimension. The different methods for accomplishing this, their underlying principles and their adaptation for mechanical and free-hand treatment will be considered.

Nearly all simple objects can be represented without ambiguity by a single outline drawing. A stick of wood looked at endwise tells nothing regarding its length. It might be a block or a long beam. By looking at it from some other point of view its true proportions are indicated. In the case of a sphere the outline from any point of view is a circle. There are three ways of completing this representation. If we draw a circle and write "sphere" on it, the size and shape are defined. If we draw two circles and indicate that these are views from two different points, the object is defined. If we draw a circle and shade its surface to represent the light and shade effect on the original, the object is defined. Each method has its advantages dependent on the use to which the drawing is put.

4. If a die is held close to the face, but far enough from the eyes to be seen distinctly, it will appear as in Fig. 1, A. On closing the right eye it appears as at B and on closing the left eye, as at C. The fact is,

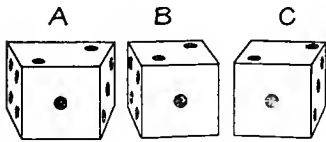

Fig. 1

we get a separate image of the object with each eye and if both eyes are open the two images are merged more or less into one. To test this, set up a card about ten inches high edgewise between B and C and look at the figures from the top edge, the card serving as a partition to shield B from the right eye and C from the left. These two images will always occur when both eyes are used, but the difference between the two is not noticeable, except when the distance of the object from the eye is small as compared with the greatest horizontal dimension of the object. A drawing like A would not be a satisfactory representation of the die, but either B or C would be satisfactory. We therefore

derive the conclusion that to **make a satisfactory representation of an object, it should be drawn as seen with one eye.** It is also true that if this drawing is to produce the same effect on the eye that the original

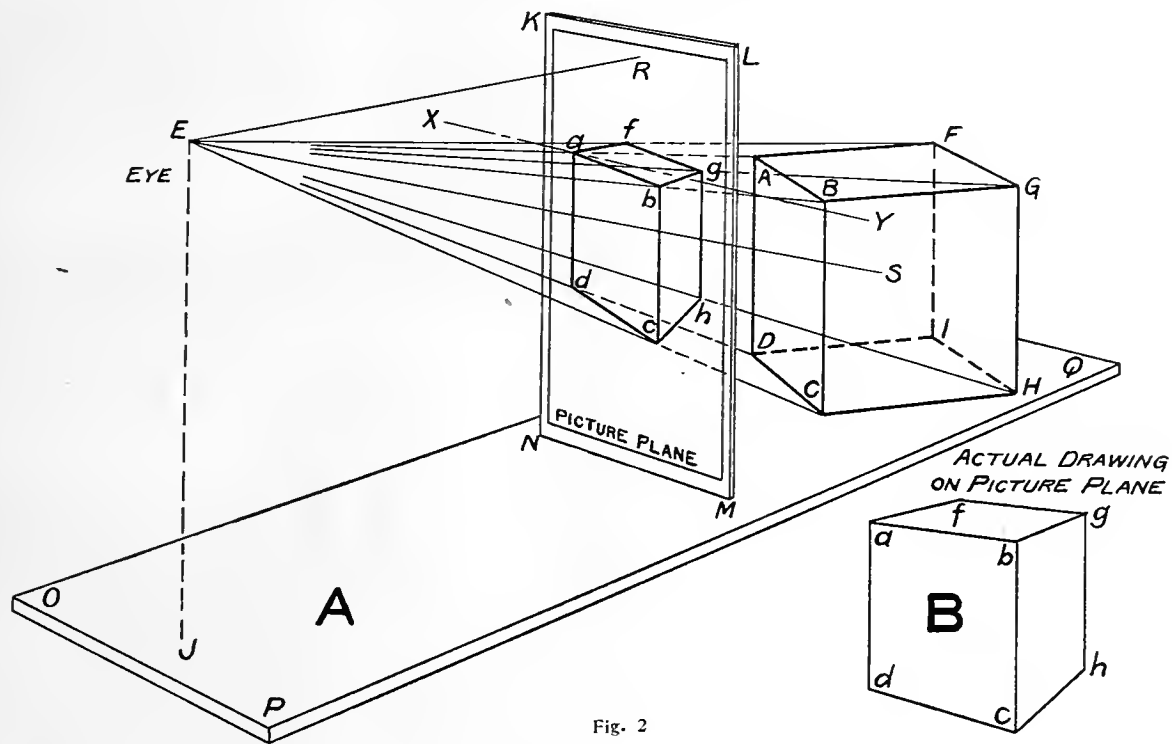

Fig. 2

object did, it should be looked at with one eye, the drawing being held at the same distance from the eye as when made.

Stereoscopic photographs made in pairs and viewed in the stereoscope give an increased reality to the third dimension. A similar effect is produced when a single picture is viewed with one eye through a conical tube or through the closed hand.

5. Referring to Fig. 2, A, we have a cube ABCD-H resting on the right end of the top of a table OPQ. Let the eye be placed at E and interpose a transparent piece of glass KLMN between it and the cube. The cube is visible to the eye, because light is reflected from its faces and as these faces have different degrees of illumination, their bounding edges appear conspicuously as lines. We may consider that the light reflected from any point, B, on the cube to the eye passes along a straight line, BE, through the glass at some point b. If we mark this point, b, on the glass, it will shut off our view of the corner, B, of the cube which is in line with it. In the same way, we may mark the other points on the glass where we see the other corners of the cube. These points are now connected forming lines which appear to coincide with the edges of the cube. That is, line ab shuts off edge, AB, bc shuts off BC and in the same way, the others. The cube could now be removed and the figure abcd-h would produce the same effect on the eye that the edges of the cube did. It stands in place of, or represents the cube. Such a drawing is called a **Linear Perspective**. It is designated Linear because it represents lines, but not the light and shade nor the color effect.

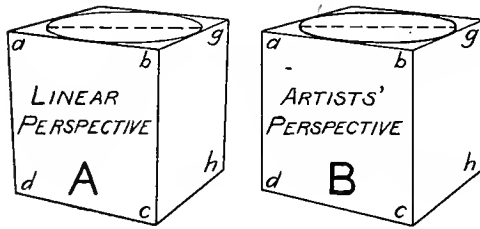

Fig. 3

Fig. 2, B, is the actual drawing, as it is on the glass plane. The transparent plane is called the **picture plane**. The line ES from the eye to the center of the object is called the **line of sight**.

6. If in Fig. 2, A, the picture plane is revolved about the line X-Y as an axis, until it is perpendicular to the line ES, the perspective drawing would change to that shown in Fig. 3, A. Here the upright edges are not quite vertical and produce a false impression regarding the object. If they are made vertical, as in Fig. 3, B, the drawing will be an **Artists' Perspective** of the cube.

7. Referring again to Fig. 2, A, suppose the eye to be moved along the line SE so that it is much further away from the object. Then the angles which the light rays make with each other at E would

become much less. If E were removed along SE to a very great distance, then the angle between the light rays would reduce practically to zero and the light rays would become practically parallel. The drawing on the picture plane would be called an **Oblique Projection**. It is so called, because if we projected, or threw on the picture plane, each point of the object by a series of parallel lines oblique to the picture plane, we should get the same result.

8. If the cube in **Fig. 2, A**, were placed further to the left with its front face parallel to the picture plane, the perspective drawing of it would be like **Fig. 4, A**. If an oblique projection were now made by removing the eye to a great distance, the drawing would be like **Fig. 4, B**. Such a drawing is called a **Cabinet Projection**. Its peculiar features are that one face of the object is shown in its true size and shape, while lines perpendicular to this face appear inclined at  $45^\circ$  and of one-half their true length.

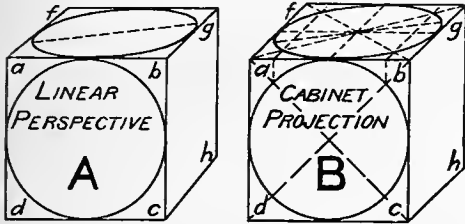

Fig. 4

9. Referring again to **Fig. 2, A**, suppose the eye be removed to a great distance from the object along a line RE which is perpendicular to the picture plane. The light rays from the object to E would then become practically parallel to RE and therefore perpendicular to the picture plane.

The drawing on the picture plane would then become like **Fig. 5** and it would be called an **Orthographic Projection**, because if the object were projected on the picture plane by lines perpendicular to that plane, we should get the same result. The term projection is always understood to mean orthographic projection unless otherwise stated. It is thus apparent that a projection drawing is merely a perspective drawing in which the eye is placed at a great distance from the object.

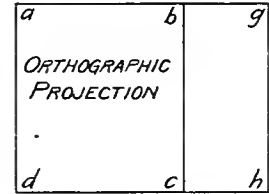

Fig. 5

10. In **Fig. 6, A**, the cube, ABCD-H, is elevated slightly from the table and turned so all its edges are oblique to the plane of projection. It is also placed so its upright edges are all parallel to a side plane, not shown, but which is perpendicular to the table top and the plane of projection. If a projection of the cube is now made on the vertical plane, its actual shape will be like **Fig. 6, B**. If this drawing be com-

pared with Fig. 2, B, a marked similarity is noticed, although there are also important differences. A projection made in this way is the basis of an **Axometric Drawing**.

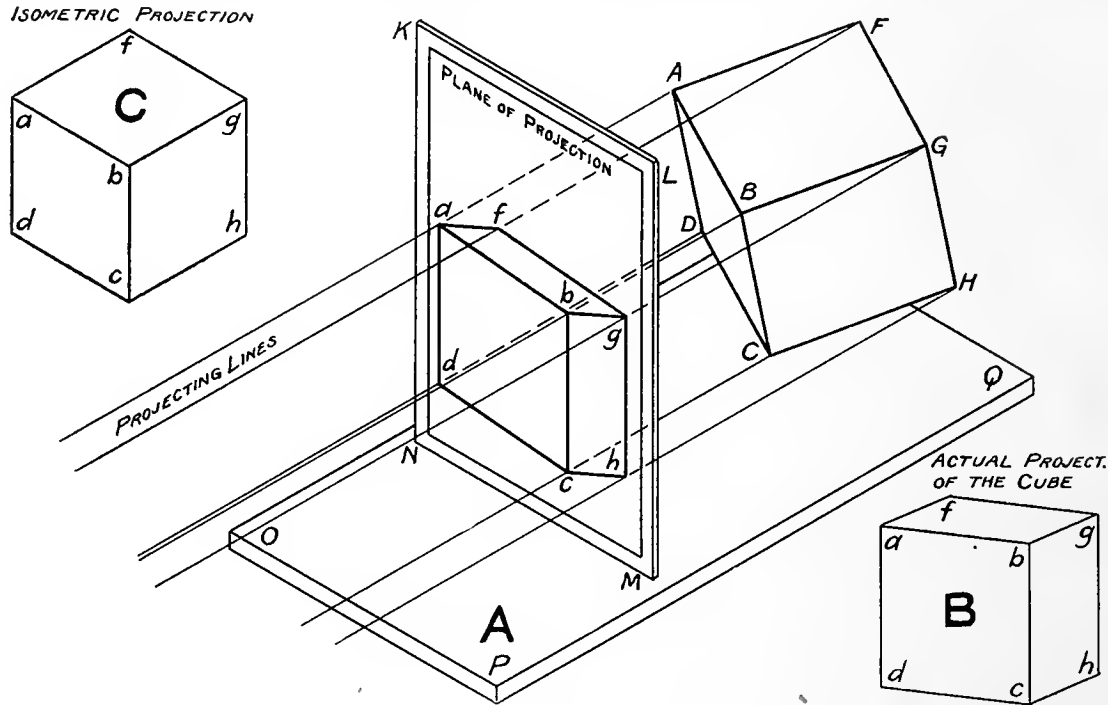

Fig. 6

11. If the cube in Fig. 6, A, had been placed so that the three edges meeting at a corner, as for instance B, were equally inclined to the plane of projection, then the resulting drawing would have been like Fig. 6, C. This is called an **Isometric Projection**. Its peculiar features are that the three edges



meeting at B are  $120^\circ$  apart and equal in length. Any line of the drawing, as for instance, bc, is shorter than the edge of the cube it represents.

12. If a drawing were made of the cube, which was exactly like Fig. 6, C, in shape, but in which the lines bc, ab, bg, etc., were each equal to the true length of the edge of the cube then we should have an **Isometric Drawing**. An isometric drawing is exactly like an isometric projection, but larger.

13. Solids have three principal dimensions; length, breadth or width and thickness or height. These terms are applied in various ways depending on whether the object is large or small, movable or fixed and other characteristics. The essential thing to remember is that these three dimensions are perpendicular, each to the others. It might be difficult to agree on the length, breadth and thickness of so irregular a form as a potato, but three measurements could be arbitrarily assumed, which would have the essential feature of such dimensions, namely, mutual perpendicularity. In the case of most artificial forms, however, there is little difficulty in selecting these principal dimension lines or **reference axes of measurement**. Generally they will be partly or entirely determined by the physical peculiarities of the object. The rectangular block and the circular cylinder are the predominant artificial forms. In the former, the edges, and in the latter the axis of symmetry and two perpendicular diameters would be selected. In the case of the sphere, three perpendicular diameters would be chosen.

If a drawing is to be useful as a guide in construction, it must satisfy the following conditions: First, it must give an idea pictorially of the shape of the object. Second, it must be of such a nature that all necessary dimensions and specifications can be appended. Third, when completed with all dimensions and specifications, the whole must be capable of being read with a minimum amount of study.

14. To permit satisfactory application of dimensions, the object must be placed so its projections show the lines of the object in their true length. To accomplish this, the object must be placed so two of its principal dimensions are parallel to the plane of projection. The result of this is to lose the third dimension, so that nearly always two or more projections of the object are required.

THIRD ANGLE  
PROJECTION.

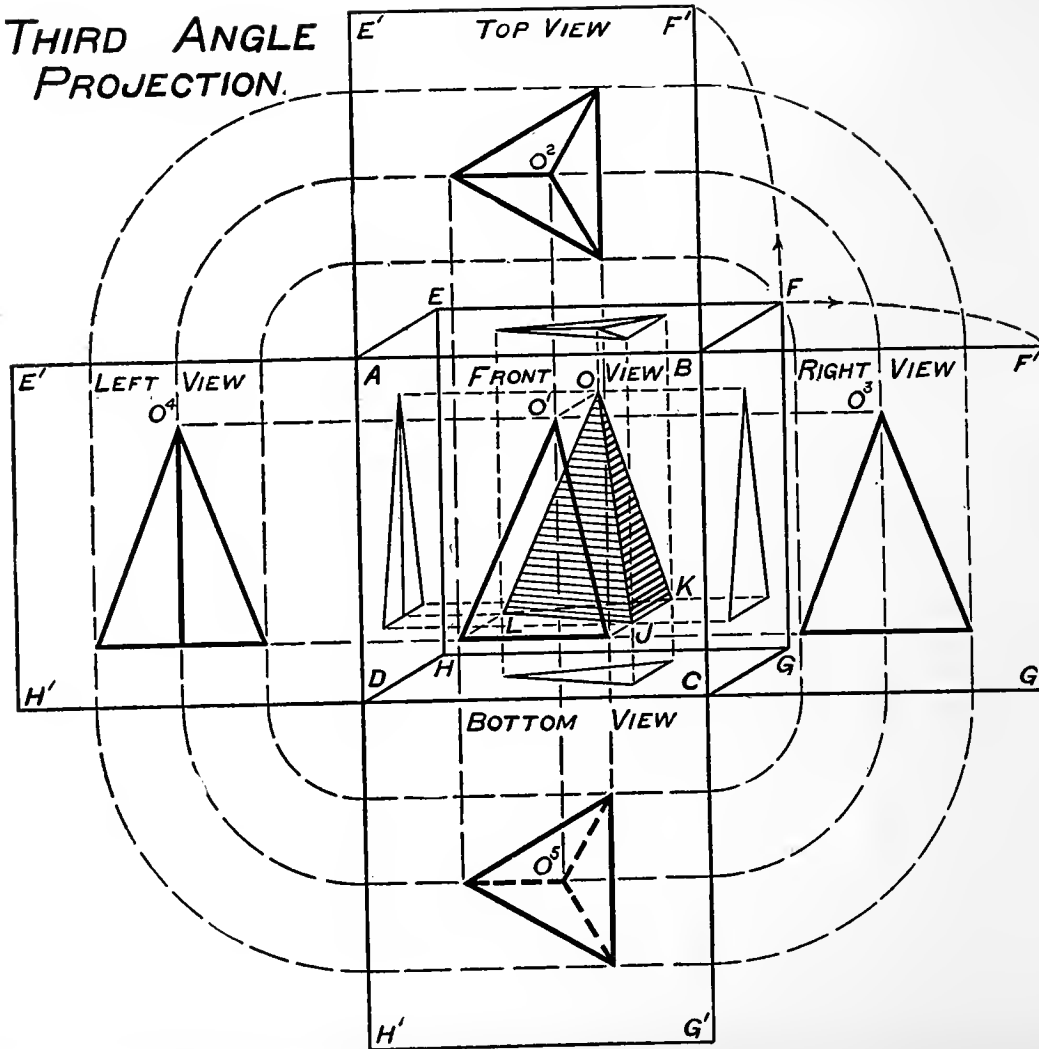

Fig. 7

In Fig. 7, the object to be represented is a triangular pyramid JKL-O. It is placed inside a glass box ABCDEFGH, the back side of which is lacking. A working drawing for such an object should give the size and exact shape of the base, the altitude and the location of the vertex relative to the base. The pyramid is therefore placed with its base parallel to the top face of the box and this location brings the altitude parallel to the front face of the box. One side of the base, JK, is parallel to the face BCFG. The pyramid is now projected onto each of the five faces. The joints of the box along edges AE, BF, CG and DH are then broken. Keeping the front face, ABCD, stationary, swing the top, bottom and two side faces about their hinge lines AB, CD, BC and AD, until they come into the same plane with the front face, as shown.

15. The projection figures on the four revolved faces are now grouped about the central projection on the front face and certain features of their relations should be noted.

Considering the central projection, or front view, the principal one, it is seen that the view obtained from above the object, that is the top view, is placed above the front view; the view of the right side is placed at the right; the bottom view below and the left view at the left of the front view. This is a logical arrangement and it is called third angle arrangement, or **Third Angle Projection**.

This is the arrangement of views used in nine-tenths of the drafting rooms in the United States. The other arrangement most used is known as first angle projection. With this method of grouping, the top view is placed below the front view, the bottom view above, the right view at the left and the left view at the right. It is entirely illogical, renders a drawing more difficult to construct and to read and has advantages in only a few instances. First angle projection is used for shop drawings in Great Britain, on the continent and by the other tenth of draftsmen in the United States.

16. It should be noted next, that any point of the object, as the vertex O, will have its projections in the front, left and right views, that is  $O^1$ ,  $O^4$  and  $O^3$ , on the same horizontal line. Also any point, as O, will have its projections in the front, top and bottom views, that is,  $O^1$ ,  $O^2$  and  $O^5$  on the same vertical line. This relation between the views is a very important one, and it facilitates greatly the making and reading of the projections.

17. Inspection of the projections shows that two views, the front and top would suffice in this case to represent the object, and accommodate all necessary dimensions. Thus the top view shows the exact size and shape of the base and the location of the vertex, while the front view gives the exact altitude. Though two views are really necessary here, for some objects, one view would suffice. On the other hand, for some very irregular machine parts, five views supplemented by auxiliary sections, dotted lines and specifications are none too many, to make them intelligible.

18. The names used in Fig. 7 for the different projections are those commonly employed. Others are also in use for architectural drawings and Descriptive Geometry. They are given in the following table.

Common Name	Architectural Drawings	Descriptive Geometry
Front View	Front Elevation	Vertical Projection
Top View	Plan	Horizontal Projection
Right View	Right Elevation	Right Profile Projection
Left View	Left Elevation	Left Profile Projection
Bottom View	Plan	Aux. Horizontal Projection

## CHAPTER II

### SHOP DRAWINGS AND BLUE PRINTING

19. A working drawing is one used by a workman in actually making the machine or structure which it represents.

20. While many of the methods of representation described in the preceding chapter might be used for working drawings, the one last described is usually employed. Though somewhat deficient pictorially it has the following advantages. The process of making the projections is easily explained and generally understood. The drawings are composed principally of horizontal and vertical straight lines and circles, all of which are easily made with ordinary instruments. The large number of views available makes it possible to avoid the confusion of lines and figures which occurs when one view only is used.

21. There are two kinds of working drawings. A **detail drawing** shows each piece by itself with complete dimensions and specifications for its construction as shown in **Fig. 9**. An **assembly drawing** shows all the parts of a machine or structure assembled, or put together: or it may show a group only of parts put together. A drawing of an engine would illustrate the first, while a drawing of the connecting rod of an engine would illustrate the second. An assembly drawing may be used in a pictorial way, merely, to give a general idea of the machine, in which case, much of hidden detail is not indicated and only the principal dimensions are given. Such a drawing may be used for assembling or for erecting the machine and then everything is shown in greater or less detail, but with only a few dimensions. An assembly drawing may be used as a shop drawing for actual construction, and then complete dimensions are given for every detail. It is obvious that only the simplest machines, tools or structures could be thus drawn. A shaft hanger or a monkey wrench would be illustrations. Such a drawing has an advantage over a detail drawing, in that there is less chance of error, both in making the drawing and in making the parts. In the case of the draftsman, the drawing helps to check the dimensions and, in the case of the workman, he sees how the parts fit together. If a machine is made on the interchangeable system, this last feature is of no particular value.

22. **Scale.** Drawings should be made large enough so they can be easily and accurately read when covered with dimensions. For convenience in filing, most drafting departments have adopted standard sheet sizes, which are particularly adapted to their special line of work.

It is often desirable to place on one sheet all the parts of a machine constituting a natural group; for instance, all the parts of the tailstock of a lathe; or all the forgings; or all the castings. These conditions, therefore, will usually determine the scale. A bridge is drawn to a greatly reduced scale, the general run of machine parts are drawn full size, while instruments or machines with exceedingly small parts, like those of a watch, should be drawn larger than full size.

23. The scales in common use are as follows, 12 inches, 6 inches, 3 inches,  $1\frac{1}{2}$  inches to one foot for ordinary details of machinery; 1 inch,  $\frac{3}{4}$  inch,  $\frac{1}{2}$  inch,  $\frac{3}{8}$  inch,  $\frac{1}{4}$  inch and  $\frac{1}{8}$  inch to one foot for larger structural work. A drawing made to a scale of  $1\frac{1}{2}$  inches to one foot is one in which  $1\frac{1}{2}$  inches

on the drawing represents one foot in the object; that is, the drawing is  $\frac{1}{2}$  of full size. Full size is a very desirable scale, especially for the designer when sketching small details, because it conveys an exact idea of the size of the part and there is also less liability of errors in dimensioning.

Some drafting rooms are provided with large vertical boards ruled with squares and used for full sized layouts. Such a layout is particularly useful in designing a new machine.

### SELECTION OF VIEWS

**24. Select those views and the least number of views that will completely and clearly represent the object.** Do not use two views, if one will suffice. If more than one view is necessary, one of them should be the front view, as this makes it possible to project from points in one to corresponding points in the other projection by horizontal or vertical projecting lines. In **Fig. 7** the object might have been placed so as to make a front view of what is now the right view. A corresponding change in the positions of the other views would have been necessary.

A judicious use of dotted lines or of sections will often permit a reduction in the number of views, as is explained in Sections 29 and 30. The pipe fittings in **Fig. 11**, the Latch Handle in **Fig. 8, A**, and the Spur Gear in **Fig. 18**, illustrate this. On the Lag Screw in **Fig. 10**, by specifying Sq. Head, an additional view is avoided. Also in the Anchor Bolt for concrete in **Fig. 10**, by giving the letter d after the  $\frac{3}{4}$ " dimension, a round bar is indicated thus making one view sufficient.

**25. While limitations of space or the clearness of the drawing may sometimes decide otherwise, yet the desirable and the customary front view is that view which shows the object most characteristically and in a natural position.** For a building, it would be the facade; for a bridge, the longitudinal view; for a pulley, the view showing the radiating arms; for a machine, the view a workman gets as he stands at work before it. Some objects have no characteristic view, others have several and a moving part like the crank on an engine may have many natural positions. These are exceptional.

**26. It is allowable to have one view showing the object with a part removed as in the Cylinder Cap, Fig. 9, while another view may show it entire or with a different part removed as in the Worm Gear-**

ing, **Fig. 18**. To condense a drawing, it is often desirable to break out a portion as in the Pulley, **Fig. 9**. Under Broken Ends in **Fig. 8** is indicated how to break rods, pipes, structural steel, etc., so as to suggest the shape of the cross-section.

An auxiliary view is sometimes needed which cannot properly be grouped with the other views. Its location or relation to the others must be very definitely specified by projecting lines or otherwise.

**27.** When two pieces are exactly alike except in some minor detail or dimension, it is often possible to make one drawing serve for both, as in the Hoist Arm Yoke, **Fig. 9**.

**28. Threaded Parts** are so numerous that to save the draftsman's time they have been conventionalized. The same is true regarding Riveting in Structural Work, and the Fittings in Pipe Systems. These are represented in **Fig. 10** and **Fig. 11**.

### USE OF DOTTED LINES

**29.** Some draftsmen show all hidden edges, but this is plainly a mistake, for in many instances it produces only a confusion of lines and obscures the meaning of the drawing. **Hidden edges should be shown, only when they contribute to the clearness of the drawing or give it a more finished appearance.** Thus in Bevel Gears, **Fig. 18**, the dotted lines complete the representation partly shown by the half section. See also Section 81 for the proper way of making a dotted line. **Figures 9, 10, 11 and 18** illustrate the use of dotted lines.

### USE OF SECTIONS

**30.** A slice or section is used to show the contour of an irregular shape or of a shape not clearly shown by dotted lines. The section of the pulley arm, **Fig. 9**, and of the Latch Handle, **Fig. 8, A**, are illustrations. The section may be specified in any one of the three ways shown in **Fig. 8, A**. A section of this kind shows nothing more than the figure cut from the object by the sectioning plane.

**31.** A **sectional view** is one which shows not only the cut surfaces, but everything back of them also. The chief use of a sectional view is to explain the internal construction of the object. In **Fig. 8, B**, is an illustration of this. Note that the center is not cut, as there is nothing inside of it to be explained.

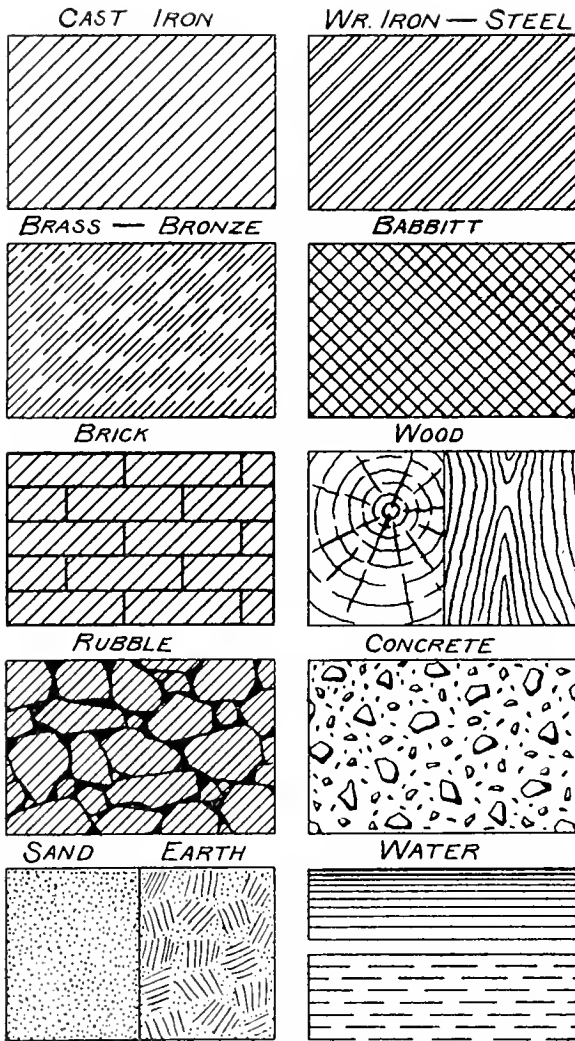

# USE OF SECTIONS

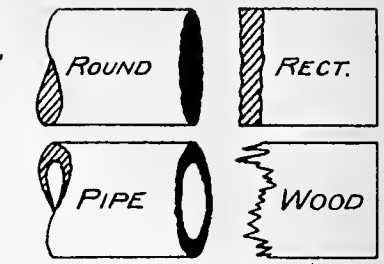
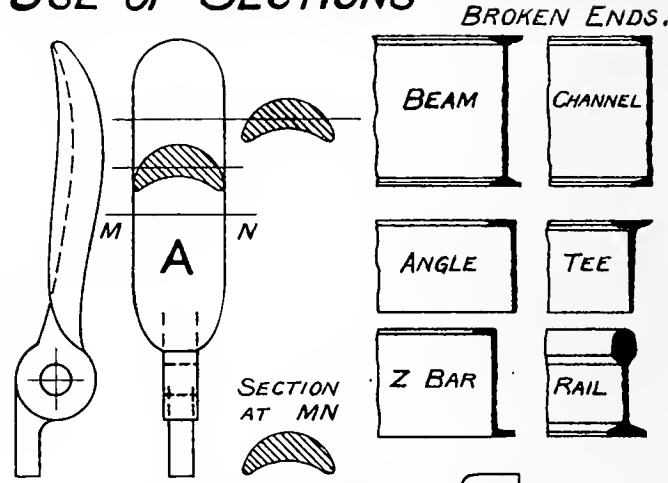

**C** MAX. SPACE WIDTH FOR A GIVEN WIDTH OF AREA.

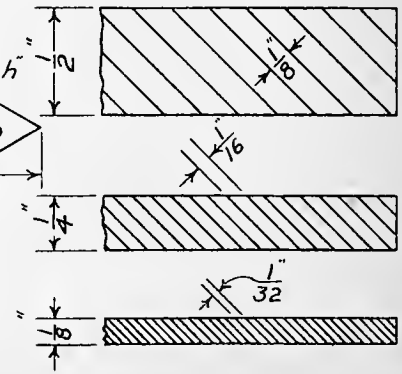
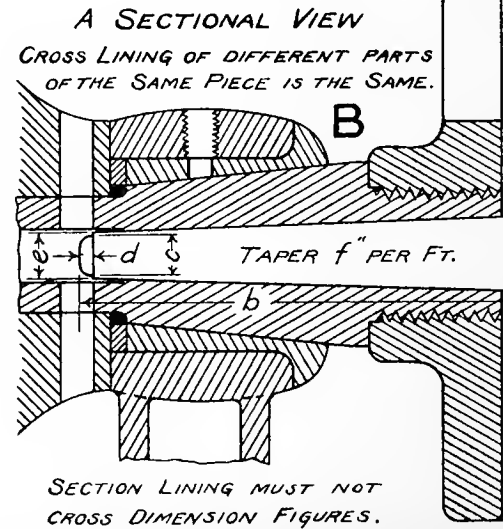
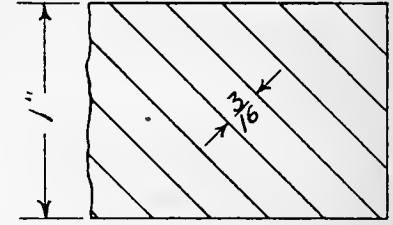

SECTION LINING MUST NOT CROSS DIMENSION FIGURES.

Fig. 8



Sectioning planes may be taken in any way to facilitate the explanation of the object, but they are usually taken parallel to some one of the planes of projection. Unless the location of the cutting plane is perfectly obvious, it should be indicated by its projection on the plane to which it is perpendicular, where it will be shown as a line, marked as in **Fig. 8, A**.

A common exception to the rules of sectioning is shown in the Pulley, **Fig. 9**.

**32.** Sometimes when it is not desirable to remove the part of the object in front of the sectioning plane, a **dotted section** may be used as in **Fig. 11, V**.

**33.** Section lining or **cross hatching** may be at any angle, so long as it is not parallel to the bounding lines of the surfaces sectioned. The angles generally used are  $30^\circ$ ,  $45^\circ$  and  $60^\circ$ , which taken both ways give six directions. If two different pieces come together in the same section, as in **Fig. 8, B**, a different angle should be used for each piece; but for different parts of the same piece, even though disconnected, the same sectioning will be used. Width of spacing is determined by the smallest sectioned part of a given piece and large areas may have wider spacing than small ones. **Fig. 8, C**, shows satisfactory spacing for different areas.

**34.** The kinds of material used in construction have multiplied to such an extent in recent years, that it is no longer feasible to have a distinctive symbolical section lining for each. In **Fig. 8** are shown some of the kinds which are in use chiefly in a pictorial way. On a working drawing these are seldom used, plain sectioning and definite printed specification of the material being the custom.

**35.** **Section lining** is one of the most tedious parts of a draftsman's work. To secure uniform spacing on large areas, a special instrument is often used. For ordinary work, spacing by the eye is sufficiently accurate. Make the first few spaces carefully and then look back to them frequently for a gage on the other spaces, rather than at the last spaces made. For free-hand sectioning, the slant from the upper right to the lower left is the one to be preferred for a right handed draftsman.

### USE OF CENTER LINES

**36.** As has been pointed out in Section 13, nearly all artificial forms have some line or lines with regard to which they are symmetrical. All turned forms have an axis of revolution, links such as the

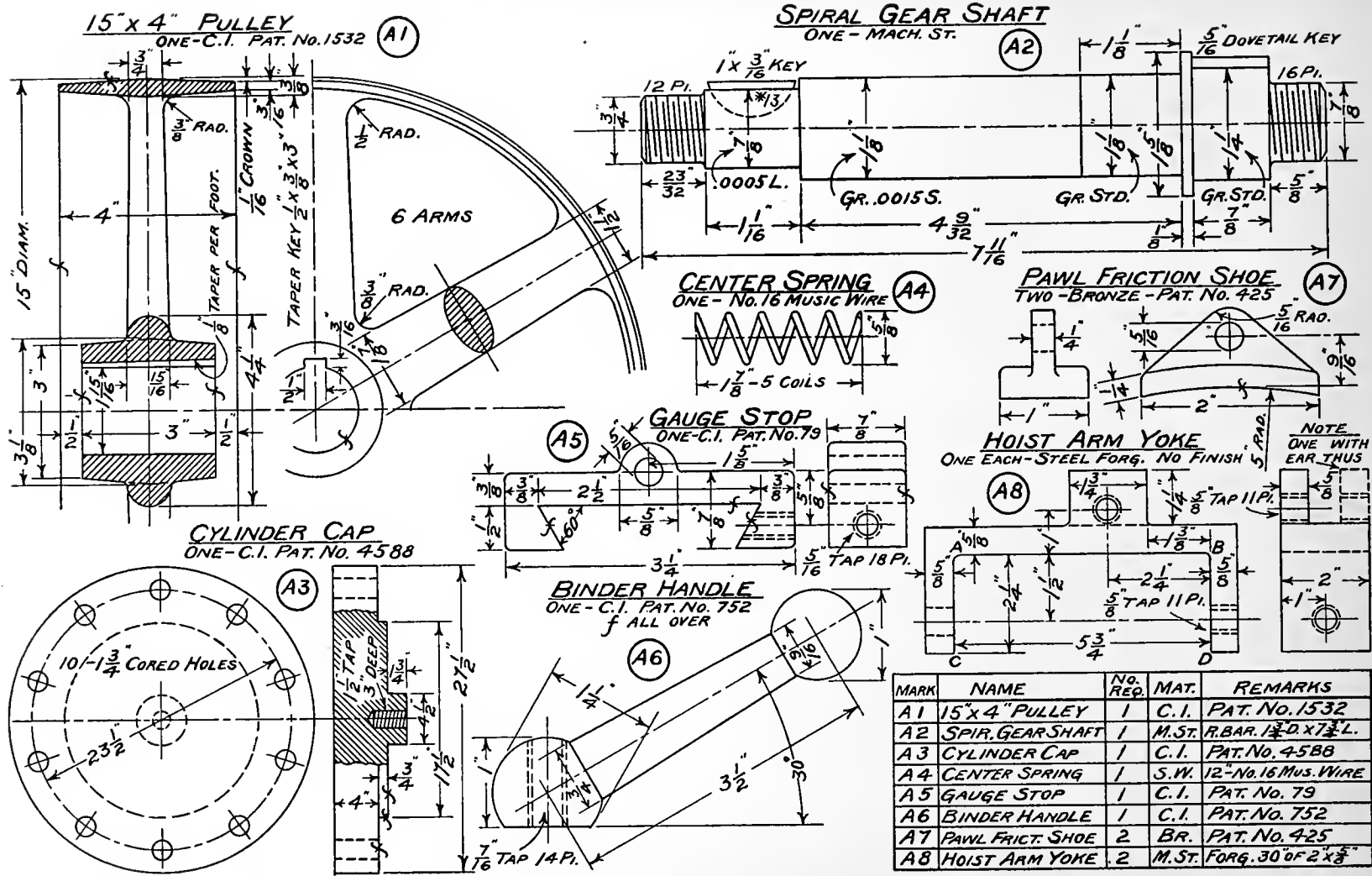

MARK	NAME	NO. REQ.	MAT.	REMARKS
A1	15" x 4" PULLEY	1	C.I.	PAT. No. 1532
A2	SPIR. GEAR SHAFT	1	M.ST.	R.BAR. 1 1/2" D. x 7 1/2" L.
A3	CYLINDER CAP	1	C.I.	PAT. No. 4588
A4	CENTER SPRING	1	S.W.	12" No. 16 MUS. WIRE
A5	GAUGE STOP	1	C.I.	PAT. No. 79
A6	BINDER HANDLE	1	C.I.	PAT. No. 752
A7	PAWL FRIC. SHOE	2	BR.	PAT. No. 425
A8	HOIST ARM YOKE	2	M.ST.	FORG. 30" OF 2" x 3"

Fig. 9

Rocker Arm, **Fig. 32**, have an axis line connecting centers of holes. In a steam-engine, there is the axis of the cylinder, the axis of the crank shaft, the axis of the connecting rod and various others. Every drilled or bored hole, every screw, bolt, gear and pulley has an axis. In making a drawing these lines are invariably drawn first, because they are very useful in making measurements. They are called **center lines** in the drawing and are usually shown as dash and dot lines. They are base lines for measurements which the workman also must use in laying out his work. In the Bevel Gears, **Fig. 18**, they are used to indicate symmetry, for dimensioning the angles and for distance between shafts. In the Pulley, **Fig. 9**, they indicate symmetry only, and this is their general use for isolated shafts, bolts, screws, etc. While they are useful in making the drawings in this last case, they serve no purpose for dimensioning and for this reason are often omitted in such drawings where they would seriously interfere with dimension figures or specifications. Note the screws in **Fig. 10**.

A center line is used for the pitch line of gears as in **Fig. 18**, and for bolt circles as in the Cylinder Cap, **Fig. 9**.

## DIMENSIONS AND SPECIFICATIONS

**37.** It has been suggested that the projections in a drawing are important only as a suitable framework to which dimensions may be attached. This is an extreme view, as any draftsman who neglected his projections would quickly discover. Projections are secondary to dimensions just as the whole drawing is secondary to the thing it represents and just as the machine it represents is secondary to its product, and so on indefinitely. It is true, however, that small errors in projections are frequent and sometimes permissible, though never desirable, while an error in a dimension may be fatal. The projection is used for illustration, while the dimension is used for measurement in construction. On this account, the dimensions and specifications of a drawing are its most important part.

**38.** Three questions arise. What dimensions should be put on a drawing? Where shall they be placed? How are they expressed? Unless the draftsman has had actual experience with shop methods of construction, he will not be very successful in his selection of proper dimensions. His first inclination is to put on such dimensions as would enable the drawing to be duplicated. He must rather keep in mind

the thing to be made, the tools the workman will use in laying out and measuring his work and the various machine operations to be performed. Constant study of approved shop drawings will give considerable information, conferences with the workmen will also be enlightening, but actual working on the machine in the shop is the best training for this part of the draftsman's work.

The principal tools used by the shop workman are the two foot rule, steel scale, calipers, dividers, square, trammel points, straight edge, protractor, surface gage and other gages for threads, drills, wire, etc.

The principal machine operations are turning, boring, drilling, milling, planing, and grinding. Hand work such as filing, chipping and scraping should not be overlooked.

Besides the workman's tools and machines there are other considerations. For instance, many years ago, the shop workman was a man of extended mechanical experience, while to-day he is more or less of a machine; oftentimes against his will. Instead of having an intimate knowledge of the machine he is helping to build, his knowledge often extends only to a part which he regularly makes. A drawing must therefore be made minutely specific and little should be left to the discretion of the workman. To this end, it is advocated that the dimensions which he will use directly should be put on the drawing, so that he need expend no intelligence in adding up partial dimensions. Thus in the Spiral Gear Shaft of **Fig. 9**, the workman in turning from the  $\frac{3}{4}$ " end to the  $1\frac{5}{8}$ " shoulder would like a dimension equal to the sum of  $\frac{2}{3}\frac{2}{2}$ ",  $1\frac{1}{16}$ " and  $4\frac{9}{32}$ ". Such a dimension is seldom given by the draftsman, because he is interested only in the direct measurements which must be correct to permit fitting the piece to the parts it adjoins in the machine. If such a dimension is given, it should be in addition to those which are direct.

If there are finished flat surfaces on the piece, dimensions should be based on these and the same is sometimes true regarding curved surfaces. Thus in the Pulley, **Fig. 9**, the thickness of the rim is based on a finished curved surface, but the thickness of the hub is not given by a measurement from the "bore."

Location of parts of a piece are often made by reference to a center line, but care should be taken to see that this is a satisfactory way of locating. Such a method may be desirable oftentimes for the pattern-maker, but might be entirely inadequate for the machinist.

It is impossible to lay down an invariable rule for the selection of dimensions, but the following is a good general guide. **Put on those dimensions which will be common to fitted parts and which must**

be exactly right; also as far as possible, give those dimensions which the workman will use in setting his tools to make the pattern or to machine the surfaces.

39. The parts which go into machines and structures may be divided roughly into the following classes: Machine and hand forgings, castings, parts made in the screw machine from rod or bar stock and those numerous parts which are standard or semi-standard in form, such as bolts, keys, wire, pipe, sheet metal, etc.

Fig. 9, A 8, shows a simple forging with no machining called for except in drilling holes. If any of the surfaces were to be milled or planed it would be indicated by an *f* mark, so the blacksmith could make the part thicker than called for by the dimension. In machining, the part would be thinned to the stated dimensions. Dimensions are selected as follows. For size of bar stock,  $\frac{5}{8}$ " thick and 2" wide. As all the fitting depends on the surfaces shown edgewise at AB, AC and BD, locations are given relative to these surfaces. Thus inside distance between end arms of  $5\frac{3}{4}$ ", distance from end of arm to inside of back  $2\frac{1}{4}$ ", distance of ear from inside of end arm  $1\frac{3}{8}$ ". Dimensions of thickness, length and width of ear are given. Location of bolt holes is given from surfaces AB and BD. Specification of size and pitch of tap is given. Note that a drilled hole is located by its center, because it is necessary to prick punch a point on the metal to take the point of the drill in starting. See also Section 27.

40. An inspection of this drawing shows that the Yoke is composed of four parts. Dimensions had to be provided therefore, to give the size of the different parts and to give their relative locations. This is true of nearly every piece used in a machine or structure.

41. The drawing of the Pulley, Fig. 9, will illustrate the dimensions needed for a casting. As the Hoist Arm Yoke was dimensioned for the blacksmith and the machinist, so here the pulley must be dimensioned for the pattern-maker and the machinist. The pattern-maker will need diameter, face width, thickness, crowning and draft for the rim; diameter of bore, diameter, length and draft on the hub; number of arms, section of arm, width and thickness of arm at rim and at hub; relative position of hub and rim and dimensions of rib at root of the arms. To allow for finish the surfaces to be machined are to be marked *f*. Note that the *f* is put on the surface where it projects as a line.

The dimensions needed by the machinist are as follows. Diameter and length of bore, dimensions of keyway; diameter, face width and crowning on the rim.

Fillets and rounded corners should be shown on the drawing, but the size is not usually dimensioned unless they are of large radius and of importance in the design of the part.

On small pulleys the inside diameter of the rim is often given, instead of rim thickness.

42. The Spiral Gear Shaft, **Fig. 9**, illustrates dimensioning for a piece turned from round stock. Here, all the dimensions are for the machinist. An overall dimension tells him how long a piece of stock to cut off and avoids the necessity of his adding the partial dimensions. This piece is made up of cylindrical sections of various lengths. The diameter and length of each is given. Where a section is ground to size, the same is specified and it is noted that one part is ground standard, that is to exact gage, another is finished a half-thousandth large, while a third is ground one and one-half thousandths small. The length, diameter and pitch is given for each threaded part, also the kind and size of each key. No finish, as such, is specified because the shaft has to be machined from a much larger piece. If a large spindle or shaft were forged approximately to size before machining, then of course, finish marks would be used. Note also the discussion on these dimensions in Section 38.

43. An illustration of the dimensions necessary for a part which has been standardized commercially is the Cap Screw or Tap Bolt of **Fig. 10**. Unless something irregular is required in the thread or head, it would be sufficient to give the diameter, length under head to extreme point and length of threaded part. See also Chapter III on Miscellaneous Details for other examples.

44. A dimension line consists of two arrows with their shafts in the same line and their points terminating on the lines between which the measurement is taken. The measurement which is given by the figures is from point to point of the arrows. The following rules and suggestions give the general practice with regard to character and placing of dimension lines and figures. **Figures 8, 9, 10 and 18** furnish illustrations. Note exception to this in Section 173.

45. Dimensions should not be crowded on a projection nor around it to such extent as to make the reading difficult.

46. To distinguish dimension lines from the outlines of the projection, make the former about one-half the width of the latter. Dimension lines are often made with red ink, so as to produce contrast in the blueprint between them and the lines of the projections.

47. Make arrows sharp pointed and not blunt.

48. If there is not space for the dimension on the projection, it may be carried to one side by **extension lines** as in **Fig. 8, C**.

49. Draw extension lines first where they are needed, then the dimension line leaving a break near its middle (or at one side when necessary) for the figures. Put on arrowheads next and figures last.

50. If the space for the dimension is very limited use one of the methods shown in **Fig. 8, C**.

51. Extension lines should not quite touch the lines they extend, as they would become confused with them.

52. Extension lines should be of the same weight as dimension lines.

53. A line of the projection must never be used as a dimension line.

54. A center line must never be used as a dimension line.

55. When the dimension line gives the radius of an arc, use an arrowhead at the arc end only. See Friction Pawl Shoe in **Fig. 9**.

56. When several dimensions are parallel, the longest is placed furthest out to avoid confusion of extension and dimension lines. See Cylinder Cap, **Fig. 9**.

57. Dimension lines for an angle are usually circular arcs with centers at the vertex of the angle. See **Fig. 18**.

58. Dimension figures give the actual size of the measurement indicated, although the drawing may be much smaller than full size. See Pulley, **Fig. 9**. Mark approximate dimensions thus, 3'—9"± See **Fig. 21**.

59. Dimension figures should read with the line and from the bottom or right end of the sheet for horizontal and vertical dimensions. For oblique dimensions, practice varies, but some draftsmen put all such figures horizontal.

In the case of explanatory drawings for tables we have an exception to the general rule. See tables at the back of the book.

60. Figures must be large enough to be perfectly legible in the blueprint which is often made from the drawing. They should be very distinctly formed. If space is too limited, take the figures to one side with an arrow to indicate where they belong.

61. The division mark for fractions should be parallel to or in line with the dimension line.

62. Many draftsmen specify all measurements up to 24" in inches and those above 24" in feet and inches. Practice is quite variable in this matter and diameters of turned forms especially are often given in inches even though of very large dimensions. Thus, a 32" shaft, a 72" pulley, a 54" cylinder.

63. If all the dimensions on a sheet are in inches, the inch mark on figures is often omitted.

64. If some dimensions are in feet and inches, then the foot and inch marks should be used and the figures separated by a dash. Thus, 2'-7", 3'-0", 7 FT.-5".

65. If the size of a fillet or of a rounded corner is of importance, its radius should be given as in the Pulley, **Fig. 9**, the figures being followed by the letter R or by Rad.

66. If the whole of a dimension line is not shown, some specification must be added to explain its extent. Thus in the Pulley, **Fig. 9**, the figures for the diameter are followed by Diam.

67. If the size of a part is changed after the drawing is completed, it is customary to change the dimension figures, but not the projection. For instance, suppose the hub diameter of the Worm Gear in **Fig. 18** were changed to  $1\frac{1}{2}$ ". Cross, but do not erase the  $1\frac{1}{4}$ " and specify below, "changed to  $1\frac{1}{2}$ ".

68. Dimensions for angles may be specified by the number of degrees and tenths or by the amount of vertical rise on a given length of horizontal base. The former should be used where the measurement



is to be made with a protractor, the latter is generally more convenient for the pattern-maker and is always used for structural work, and the pitch of pipe lines. See Fig. 21.

69. Dimension figures should never be crossed by a line, nor placed so as to interrupt a line of the projection, nor an extension line. Note also the break in section lining about figures and lettering. See Figures 9 and 18.

70. Give diameters of circles and the radius of a circular arc less than a semi-circle. If the location of the center of a circle or arc is not indicated by lines of the drawing it should be definitely located and dimensioned.

71. Do not duplicate a dimension given in another view, except for purposes of identification of a part otherwise not easily distinguished.

72. Dimensions should be placed where they will be found quickly by the workman. They can generally be arranged in natural groups and should be put on one view as much as possible. Thus in the Pulley, Fig. 9, all the hub and bore dimensions form a group and are on the same view. The keyway dimensions are shown in the view where all can be put on. For the lengthwise partial dimensions on the Spiral Gear Shaft, Fig. 9, an arrangement very nearly in a straight line is desirable.

73. Supplementary to the dimensions is the printed matter that accompanies the drawing. The name of the piece, usually some identification number or symbol, the number of pieces required for one machine or structure, the material, the kind and extent of finish, heat treatment such as tempering and any other pertinent and necessary facts are grouped together above or below the drawing to form a **sub-title**. See Figures 9 and 18, for examples.

74. Notes are also added to explain special details, but these should be exactly definite and as few as possible. See notes on Bevel Gears and Spiral Gears, Fig. 18.

75. Drive, force and shrink fits should always be specified.

76. If a piece is hardened, tempered, case hardened, blued, nickled or oxydized it should be noted.

77. Specifications are often made by giving name of manufacturer or the trade name or number by which he designates a machine or part. Thus, No. 825 Ley Bushed Chain.

## NOMINAL SIZES

78. Specifications for much of the material that is used in construction are given by gage size, nominal size or size of one or more important dimensions. Some of the commonest of these are as follows:

**Belting.**—For leather belts, give width in inches and the number of thicknesses. Thus, a 6" double belt. For cotton and rubber belting, give width and ply. Thus, a 4"–3 ply rubber belt.

**Chain.**—For hoisting chain, give the diameter of rod from which it is made. For transmission block chain, give the circular pitch and the width of block. Thus, pitch 1"–width  $\frac{5}{8}$ ". For transmission roller chain, give the circular pitch, the width between inner links and diameter of roller. Renold chain is specified by circular pitch and the nominal outside width. Under 1" pitch the actual exceeds the nominal width, but above that pitch they are alike.

**Drilled Holes.**—When of small diameter, give size by Drill Gage number. **Table 5.**

**Hangers, Wall Brackets and Pillow Blocks.**—These are designated by the diameter of shafting they support. The drop of hangers is also given.

**Machine Screws.**—Give diameter by Screw Gage number, number of thread and length. **Table 5.**

**Pipe.**—For standard wrought iron pipe, give the nominal inside diameter. **Table 11.** For spiral riveted pipe give inside diameter and thickness by B. W. G.

**Pulleys.**—Give diameter, face and bore in inches.

**Rod and Bar Stock.**—Give dimension between flats for square, hexagon and octagon sections. Give width of flat on half round.

**Rolled Sections.**—See Section 169 for I beams, channels, etc.

**Rope.**—Give largest diameter over strands. Number of strands and wires per strand are sometimes added.

**Shafting.**—Turned shafting for transmission purposes is often designated by its nominal diameter, the diameter before turning. Thus, by 2" turned shafting would be meant shafting having an actual diameter of  $1\frac{15}{16}$ ". To avoid all chance for error the **actual diameter should always be specified.**

**Sheaves.**—Give the diameter at the pitch line of the rope.

**Sprockets.**—Give pitch diameter.

**Sheet Metal.**—Thickness is usually given by gage number or in thousandths of an inch. Plate is also designated by thickness in vulgar fractions, thus,  $\frac{5}{16}$ " and by weight in pounds per square foot. **Fig. 14.**

**Tapers.**—Specify by the number and the standard, thus, No. 16 B. & S. **Table 13.**

**Tubing.**—Give outside diameter and thickness by gage number.

**Wire.**—Give diameter by Wire Gage number or in thousandths of an inch. Wire used for electrical purposes is often designated by its area in circular mils. A **mil** is  $\frac{1}{1000}$  of an inch. A **circular mil** is the area of a circle whose diameter is one mil. **Table 5. Fig. 15.**

**Wire Cloth.**—Give the number of meshes per lineal inch and the gage number of the wire.

**Wood Screws.**—Give the number by Screw Gage and length. **Table 5.**

79. Specifications for the common forms of fastenings, such as are shown in **Fig. 10**, are given in Chapter III.

### LINES OF THE DRAWING

80. The various lines used in working drawings are shown in **Figures 9, 10, 18, 20, 21, 22 and 23.** General practice is to make all lines with black ink, but many draftsmen prefer red for all lines except those of the projections, because the two sets of lines are thus easily distinguished in the drawing and in the blueprint made from it. There are three features to be considered in determining the character of these lines.

They should be easily distinguished from each other in the original drawing and in the blueprint, and should not consume too much time in the making.

81. The **visible lines** of the object are shown by continuous or full lines not less than  $\frac{1}{8}$ " in width for ordinary drawings.

**Hidden lines** of the object are represented by dotted lines not less than  $\frac{1}{8}$ " in width. The length of dot will vary with the size of the drawing and length of the line. **The space between dots or dashes should be just long enough to show that the line is broken.** The end dot should start at the full line,

provided it does not thereby become a continuation of some other line. Otherwise, start the dotted line with a space. See dotted lines in Bevel Gears, **Fig. 18**.

**Center lines** may be full lines or of alternating dots and dashes. In either case they should not exceed  $\frac{1}{2}$  the width of lines of the projection.

**Extension lines** may be full lines or dash lines and of the same weight as center lines. They should not quite touch the lines they extend.

**Dimension lines** are usually made as two long dashes with a break for the dimension figures. For long lines they may be several long dashes. Width of line should be same as for center lines.

**Shade lines** should be at least twice the width of the lines of the projection.

**Other lines** may be combinations of dot and dash lines.

### GENERAL ARRANGEMENT OF A SHEET

**82.** The general arrangement of a sheet of details will be similar to that of **Fig. 9**. Each part with its projections, specifications, dimensions and sub-title should constitute a group somewhat separated from the others, so as to be easily picked out by the eye.

**83.** The **title** of a sheet, described in Section 299, will usually be placed in the lower right hand corner. It will provide a variety of information according to the system in use.

**84.** Near the title is often placed a **Bill of Material** similar to that in **Fig. 9** and **Fig. 21**. It is to facilitate the work of order and cost clerks. Many prefer a different order by which the number of pieces required is given first and the name of the piece second.

**85.** There are usually placed at the lower right and upper left hand corners numbers or symbols to designate the sheet and its contents for convenience in filing, indexing and reference.

### REPRODUCING DRAWINGS

**86.** Drawings are commonly reproduced for the shop by **blue-printing**. If a drawing is to be thus reproduced, it should be made on **tracing cloth**, a thin, translucent, specially prepared linen or on thin

paper such as **linen bond**. If tracing cloth is to be used, the drawing is first made on paper with pencil in the usual way. The tracing cloth is then stretched tightly over the drawing and thoroughly tacked down onto the board. One surface of the cloth is usually glossy and the other side dull. Both take ink equally well, but some prefer the dull side as it can be pencilled on. Whichever side is used, the surface should be sprinkled with a little ground **chalk** and rubbed over with a cloth. This is done to remove greasy places which do not take the ink well. The drawing is then inked as if on the original sheet. The natural tendency is to use **fine lines** on a tracing, because it is so easy to make them. This is entirely wrong as the fine ink lines do not print out clearly, unless they have been made with hand ground ink. It is therefore best to **use the heaviest ink line possible** and this will be determined by the closeness of lines in the smallest details.

If thin bond paper is used, the drawing is pencilled and inked in the usual way.

**87.** To print, the tracing or bond paper drawing is put in a printing frame with the ink lines next to the glass and the prepared print paper is laid on it, the sensitized surface being put against the drawing. The drawing is now exposed to the sun and allowed to print until it is possible to see just the least discoloration under the ink lines. This part of the sensitized surface having been protected from the light should retain its original color. The print is taken from the frame and washed thoroughly in a sink of clean water for about a half hour after which it is rinsed and hung up to dry.

**88.** The beginner nearly always overprints and thus gets poor lines. If the paper is fresh and the exposure is right, these should be a clear white. In **washing the print**, be careful that air bubbles do not collect on its surface as they will cause spotting. Also be careful not to spatter wash water on the drawing as it causes stains which cannot be erased.

**89.** It is sometimes desired to make **alterations** in a blueprint. The white lines can be obliterated by ruling them with blue ink. White lines can be made on the blue surface by using a solution of common washing soda in the pen instead of ink.

**90.** Another process, known as the **negative-positive process** is sometimes used when it is desired to get prints just like the original drawing instead of reversed in color. In this process, a special paper is

used which requires more manipulation than the common blueprint paper. Briefly, the method is this. The drawing is put in the frame, its blank side against the glass so that the sensitized surface of the print paper comes next to the ink lines. The resulting print is negative in color and reversed in position. After developing, fixing, washing and drying, this negative print is put in the frame with its printed surface up so that the sensitized surface of a fresh piece can be in immediate contact with it. The print obtained this time is reversed in color and position with respect to the negative and is therefore like the original. By this process it is possible to make sharp, clearly defined prints even from drawings which are on heavy and almost opaque paper. The exposure is of course a prolonged one. Ordinary blueprint paper, if fresh, will give fair prints by this process.

## CHAPTER III

### MISCELLANEOUS DETAILS OF CONSTRUCTION

Many of the simpler parts used in construction are common to all or most machines and structures. These will be considered at some length in the order of their arrangement in **Figures 8, 9, 10, and 11.**

#### TYPES OF SCREW THREADS FIG. 10

**91.** The **Sharp Vee** is used to only a limited extent, as it is difficult to keep taps and dies for it in condition. The sharp edge of the V wears down and approaches the shape of the U. S. Standard Section. Its lack of clearance makes it difficult to fit, if cut in the lathe.

**92.** The **Sellers or U. S. Standard** is like the Sharp Vee with the point of the triangle flattened  $\frac{1}{8}$  of the height, at top and bottom. This is the thread in common use in the United States. Depth is .6495p.

**93.** The **International Standard** adopted by the metric countries is not shown here. It is exactly the same shape as the Sellers thread except that the point of the V at the bottom of the thread is rounded  $\frac{1}{16}$  of the height. This is an improvement over the Sellers section, in that it provides clearance and facilitates fitting.



94. The **Whitworth**, or English standard, has an angle of  $55^\circ$  and the point of the V is rounded top and bottom  $\frac{1}{8}$  of the height. Depth is  $.64p$ .

95. The **Buttress** thread gives a form of great strength where the load is always in the same direction. Its friction is low and it is easily fitted. It finds application in Bench Vises and Screw Jacks. Depth is  $\frac{3}{4}p$ .

96. The **U. S. Buttress** is a modified form of the preceding used by the U. S. Government for breech blocks of guns and for armor plate bolts.

97. The **Square** thread is used for power transmission screws where large pressures are applied. Its friction is low, but it is expensive to fit. Dimensions as given in the figure are modified a few thousandths of an inch to procure easy fits.

98. The **Acme** thread is used for screws like the lead screw on a lathe. It has some of the good qualities of both the U. S. Standard and the Square threads. It is often called the Powell thread. Dimensions as given in the figure are modified a few thousandths of an inch to procure easy fits. Exact depth is  $\frac{1}{2}p + .01''$ .

99. The **Knuckle** thread is useful where a thread is liable to be bruised, as it will stand many knocks and yet work in its nut. Depth is  $\frac{1}{2}p$ .

100. **Pipe Thread**, not illustrated, has a  $60^\circ$  Vee rounded slightly at top and root, and a taper of 1 in 32 measured on a radius.

### CONVENTIONAL SCREWS FIG. 10

101. The true curve of the edge of a screw thread is a **helix** and this, of course, cannot be drawn every time a thread is represented. Various conventional representations are therefore used which show the thread with more or less accuracy and save the draftsman's time. Those shown at A, B, and C are the ones commonly used. The thread lines are drawn at a slight inclination approximately that of the actual thread of the same pitch. The spacing is also approximately true. Note that the short lines are made heavier. At C is a form, useful where the space will not permit the intermediate lines.



102. In the **Vee R. H. Single** screw, the thread makes eight complete turns or wraps about the cylinder in one inch. It is therefore called a No. 8 thread or an 8 Pitch thread. The **linear pitch** of the thread is really  $\frac{1}{8}$ ", or the distance between centers of two adjacent Vees. In the **Sq. L. H. Sing.** screw, is shown a thread in which the linear pitch is  $\frac{1}{4}$ ". There are four wraps in one inch and it is called a 4 Pitch thread.

103. In the **Square Double** screw, two distinct threads are wound on the cylinder, as indicated. Each wraps around the cylinder twice in one inch and each is really a 2 Pitch thread. The distance between adjoining threads, however, is only  $\frac{1}{4}$ ", so to avoid confusion, it is customary in the case of **multiple threads** to use the actual linear pitch of the thread or helix and designate it **lead**. So in this case, we have  $\frac{1}{2}$ " lead.

104. However elaborately a screw is drawn, the pitch should be specified always. If it be irregular in any way, that is, if it be multiple threaded, or left handed, it should be so designated.

### CONVENTIONAL THREADED HOLES FIG. 10

105. Here we have various ways of showing threaded holes, so as to save time and avoid the confusion of lines. A and D are not much used. Note the angle of  $120^\circ$  used to show the **drill point**. Note also that the depth of the hole is not measured to the drill point, but to the corner. If two parts are threaded together and then cut with a sectioning plane, it is necessary to draw the thread. See Fig. 8, B.

### COMMON FORMS OF BOLTS FIG. 10

106. **Through Bolts** are always used where possible, in order to reduce expense. In some cases, however, as on a steam engine cylinder end, it may not be possible to get at the head of a bolt on the back of the cylinder flange. In such a case, **stud bolts** would be used for holding on the cylinder head. A **tap bolt** is sometimes used for the same purpose, if the cylinder head will not be removed very often. Where a bolt of this kind is frequently turned in and out of a hole tapped in cast iron, the thread on the hole is quickly destroyed. Such a bolt is therefore most suitable for a permanent connection.

107. The **anchor bolt** for concrete is to be placed while the concrete is yet plastic. The one for stone is driven into a hole that flares slightly at the bottom, the wedge spreading the end to fit it.

108. If one view of a bolt head or nut is shown and then only for pictorial purposes, the hexagonal form should show three faces and the square form should show one face. There can be no question then as to which is intended. If one view only is shown in a working drawing, show two faces for the hexagonal form and one for the square. This permits dimensioning the distance between flats, a measurement the workman will need, if the faces are milled.

109. The needed dimensions on the **stud bolt** are shown. See **Table 4** for sizes. Nut and bolt dimensions follow no universal standard. They are most frequently made by the U. S. standard, the proportions for which are given in the drawing and in **Table 1**. These values apply to both square and hexagonal forms. Note the appearance of the chamfer on head and nut. Its angle is  $45^\circ$ . Note also that the bolt points are either rounded or beveled at  $45^\circ$  and that the thread lines do not run to the extreme point. The length of a bolt is measured from under its head to its extreme point. The diameter and length of thread are also essential dimensions. Pitch of thread need not be specified on a through bolt, but it is necessary on a tap or stud bolt, so as to agree with the tapped hole into which it will go.

110. The table on **Standard Bolts and Nuts** is the **Franklin Institute** or **Sellers' Standard** and is for rough bolts and nuts. Referring to the dimensions given in **Table 1**,

$$F = 1\frac{1}{2}D + \frac{1}{8}" \text{ for head and nut. Thickness of head} = \frac{F}{2} \text{ Thickness of nut} = D.$$

For finished bolts and nuts,

$$F = 1\frac{1}{2}D + \frac{1}{16}" \text{ Thickness of head equals thickness of nut} = D - \frac{1}{16}"$$

The U. S. Government uses the rough standard for both rough and finished bolts and nuts so the same wrenches may be used on either.

The **Manufacturers' Standard** follows these dimensions for bolts.

$F = 1\frac{1}{2}D$  for heads. Thickness of head =  $D - \frac{1}{16}"$  for sizes  $\frac{1}{4}"$  to  $\frac{9}{16}"$ , is  $\frac{17}{32}"$  for  $\frac{5}{8}"$  and =  $D - \frac{1}{8}"$  for sizes  $\frac{3}{4}"$  to  $2"$ .

The dimensions of nuts will vary according to the manufacturer.

## SCREWS AND SCREW HEADS FIG. 10

111. The terms "bolt" and "screw" are used interchangeably by so many people that it is difficult to distinguish between them. We may classify them roughly by saying that a bolt is a screw and a nut, while a screw is simply the one piece.

The ways of representing and dimensioning the commoner kinds of screws are shown here. For the **Collar, Knurled, Fillister** and **Button** head screws, the length is measured from under the head to extreme point. For the **Flat head**, however, it is the overall length which is taken. Most bolts and screws pull the parts they connect together. A **Set Screw** acts by forcing them apart. For this reason it has to be case hardened, at least on the point.

112. Many screws are turned out of bar stock and their diameters run on the common fractional sizes. They are called **milled or cap screws**. They are frequently case hardened. The dimensions used by the different manufacturers vary slightly and the ones given in the tables are principally those of the Worcester Machine Screw Co.

**Diameters of the Square and Hexagon head screws range from  $\frac{1}{4}$ " to  $1\frac{1}{4}$ ". See Table 2.**

113. Diameters of **Flat, Round and Oval Fillister** head screws range from  $\frac{1}{8}$ " to 1". As used, the entire head may project or it may be sunk partly into the metal by counterboring the hole. See Table 3.

114. Diameters of **Flat and Oval Countersunk** head screws and **Button** head screws range from  $\frac{1}{8}$ " to  $\frac{3}{4}$ ". A common angle for the countersunk head is  $70^\circ$ . See Table 3.

115. Diameters of **Collar** head screws range from  $\frac{1}{4}$ " to  $\frac{3}{4}$ ". It is really a screw with a fixed washer attached. It is used where the screw must be frequently removed, as for instance, on the jaws of a milling machine vise. Heads are usually case hardened. See Table 4.

116. Diameters of **Set Screws** range from  $\frac{1}{4}$ " to  $1\frac{1}{4}$ ". There are several kinds of points and heads as shown in the table. Regular set screws have cup or oval points, have square heads but slightly greater than that of the body and are case hardened. See Table 2.

117. **Machine Screws**. Small screws are made from wire by upsetting one end for the head. Their diameters are therefore the wire sizes and are specified by the numbers of the screw gage. These

are designated **machine screws**. See Machine Screw Gage and the A. S. M. E. standard for machine screws in **Table 5**. **Commercial sizes** of brass and iron Flat, Round and Fillister head screws have these diameters by gage. Numbers 2, 3, 4, 5, 6, 8, 10, 12, 14, 16, 18, 20, 24, 30. Lengths from  $\frac{3}{16}$ " to  $\frac{5}{8}$ " vary by 16ths, from  $\frac{5}{8}$ " to  $1\frac{1}{2}$ " by 8ths, and from  $1\frac{1}{2}$ " to 3" by 4ths.

**118.** Punched washers are designated by the largest size of bolt with which they can be used, and their thickness by Birm. Wire Gage. See **Table 9**. For sizes of **Cast Washers**, see **Table 10**.

**119.** A **lag or coach screw** is a large, wood screw made to be driven by a wrench instead of a screw-driver. Necessary dimensions are as shown.

These screws have square or hexagonal heads. From  $\frac{1}{4}$ " to  $\frac{5}{8}$ ", the **diameters** advance by 16ths of an inch and from  $\frac{5}{8}$ " to 1" by 8ths. The **lengths** from  $1\frac{1}{2}$ " to 6" advance by half inches and from 6" to 12" by inches.

**120.** The included angle for **flat head wood screws** is  $82^\circ$ . The diameter of the head is approximately 1.9 times the diameter of the body of the screw. The range of **commercial lengths** is as follows: Up to 1" by 8ths, from 1" to 3" by 4ths, and from 3" to 5" by half inches. See Wood Screw Gage in **Table 5**.

#### RIVET FASTENINGS FIG. 10

**121.** There is a great variety of rivet forms and only the three common ones are shown. Diameter and length as indicated designate the size. Note how the length of the countersunk head type is measured. Proportions of heads vary, but are approximately as shown in the illustration.

Button and Countersunk heads are used in structural work, Pan heads for boilers and Countersunk heads for hull plating. See also the chapter on Structural Drawing and **Table 14**.

#### KEY FASTENINGS FIG. 10

**122.** There are three types of keys in common use as follows: A **Taper** key, such as is used for fastening a pulley to a shaft so it cannot rotate nor slide on the shaft, fits on all sides and is driven in tight.

If its small end is not accessible for driving out, then a **Gib Head** key is used like the one shown in the drawing. The section under the head is commonly square. This dimension and the length under the head are sufficient to designate it. If it is not square, give width  $\times$  thickness  $\times$  length. See **Table 7**.

**123.** The following **commercial sizes** are those of keys made by the Standard Gauge Steel Co. These keys are square at the large end and have a taper of  $\frac{1}{8}$ " in 12". Size of **large end** varies from  $\frac{1}{8}$ " to 3" by 16ths of an inch. **Lengths** from 1" to 24" vary by half inches. See **Table 6**.

**124.** The second type of key fits on the sides and prevents relative rotation but not sliding endwise. These keys are commonly square and are dimensioned as in the drawing. The **Whitney** or **Woodruff** key belongs to this class. Its size is designated by manufacturer's number, but the length and width are often given so as to show the size of cutter required. See **Table 1**:

**125.** The third form of key is the **Feather** key. This is usually rigidly attached to the shaft or to the hub, so as to permit sliding of the parts endwise without its loosening. These keys are generally of greater depth than the other kinds. The depth or thickness of a key is its radial dimension as it lies on the shaft.

**126.** A **Key** is subjected to shearing on a longitudinal section. A **Cotter** is a similar fastening which is subjected to shear on a transverse section. Cotters are often called keys especially on the connecting rod of an engine where they are used to draw up the boxes. A cotter is tapered and is driven tight to draw the connected parts together. It may hold by friction or be held by a set screw. In specifying, use the dimensions shown in the drawing.

**127.** A **spring cotter** or split pin is not used for drawing parts together, but to prevent a pulley or nut from coming off a shaft endwise. After pushing the pin through its hole, the ends are spread thus preventing its working out. Diameter at the neck and length under head to extreme point are the necessary dimensions. **Diameters** from  $\frac{3}{32}$ " to  $\frac{7}{32}$ " vary by 64ths of an inch, from  $\frac{1}{4}$ " to  $\frac{1}{2}$ " by 16ths of an inch and from  $\frac{1}{2}$ " to  $\frac{5}{8}$ " by 8ths of an inch. See **Table 10**.

**128.** Note the dimensions and specifications for the coiled **spring** in **Fig. 9**.

STRAIGHT COUPLING REDUCING COUF.

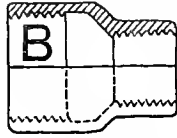

CAP



PLUG



TEE

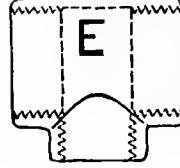

Y BRANCH

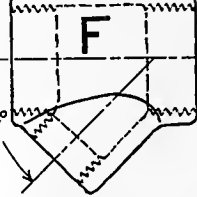

ELBOW

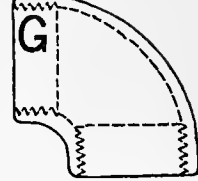

45° ELBOW

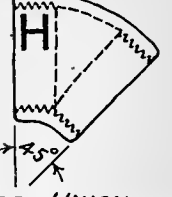

OPEN RETURN BEND

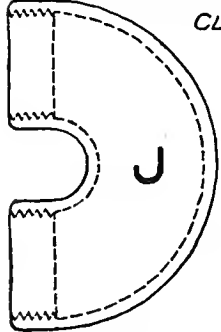

CLOSE RETURN BEND

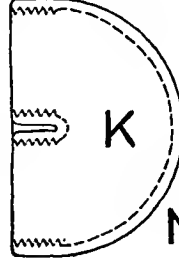

SHORT NIPPLE

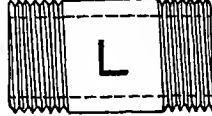

REDUCING BUSHING



CLOSE NIPPLE

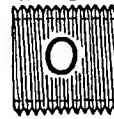

CROSS

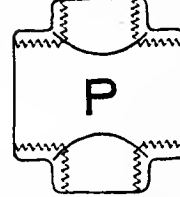

SCREW UNION

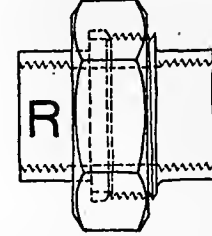

FLANGE UNION

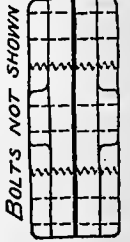
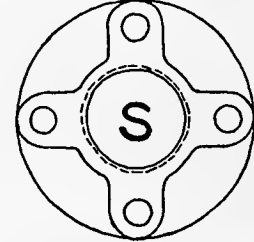

BOLTS NOT SHOWN

BEADED FITTING

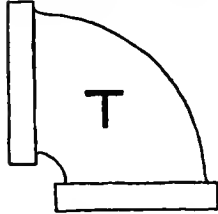

FLANGED FITTING

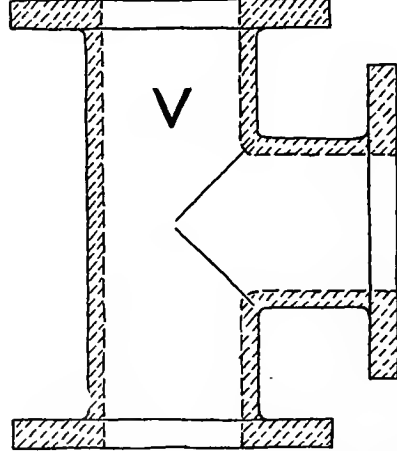

SEWER PIPE FITTING

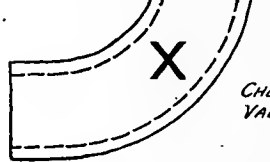

RAILING FITTING

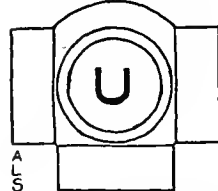

FOR RAPID CONVENTIONAL SKETCHING

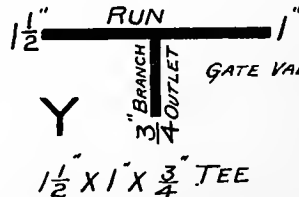
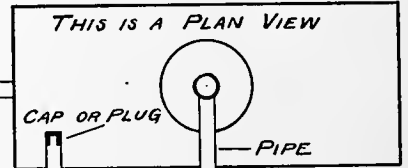

Fig. 11

## PIPE CONNECTIONS FIG. 11

129. Ordinary **Standard** wrought iron pipe is designated by its nominal inside diameter. Thus a 12" pipe is just 12" in internal diameter, while a  $\frac{1}{8}$ " pipe is .269" in internal diameter. See **Table 11** for properties.

**Extra** and **Double Extra** pipe are of the same outside diameter as **Standard**, so their inside diameters have no significance. The thread for a pipe is special, standard for the various sizes and is never specified in a drawing. See Section 100. If a hole is tapped for pipe the specification is, **2" Pipe Tap**, for instance.

130. The term **fittings** applies primarily to the parts used for connecting the different lengths of pipe. Valves are not considered fittings. Sketches of the various fittings and their names are given in **Fig. 11**. Their use is indicated in the sketch showing a pipe "layout."

The **size** of a fitting or valve is given as that of the largest piece of pipe which can be screwed into it.

A **straight coupling** connects two pipes of the same diameter, while a **reducing coupling** connects two pipes of different diameters. Many fittings are threaded **right and left** to permit of making connections on a circuit of piping. If the connection must be sometimes broken, it is better to use **unions** to complete the circuit.

**Elbows** and **bends** provide for changes in direction, while **Tees**, **Crosses** and **Y branches** provide for branches and for changes of direction.

On a fitting with side **outlets** the main part is called the **run**. The fitting is always specified by giving first the dimensions of the run and then those of the outlets. In **Fig. 11**, **Y**, is shown how to designate a Tee.

A **flange union** is used where the joint must be tight and the pressures are high, as on steam piping. **Screw unions** are used on the smaller sizes of pipe, especially for water pipe.

**Gate**, **Globe** and **Check Valves** are shown in **Figs. 12 and 13**. Where the fluid is a liquid, the gate valve is commonly used. For small steam pipes and where steam must be throttled, the globe or angle valve is generally used. On high pressure, large size steam pipe lines, gate valves appear to be preferred,

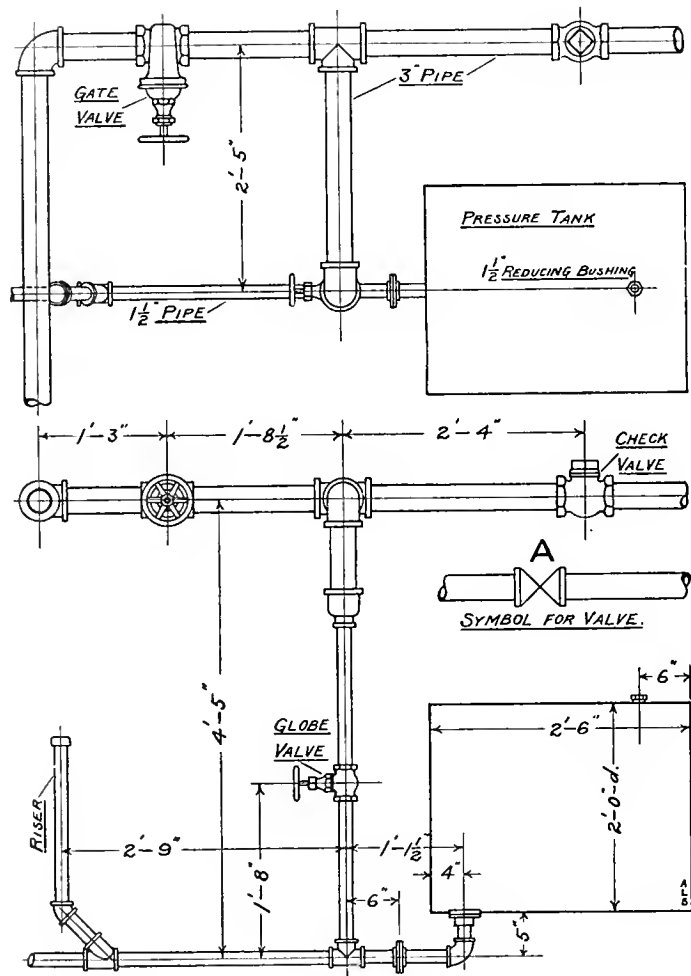
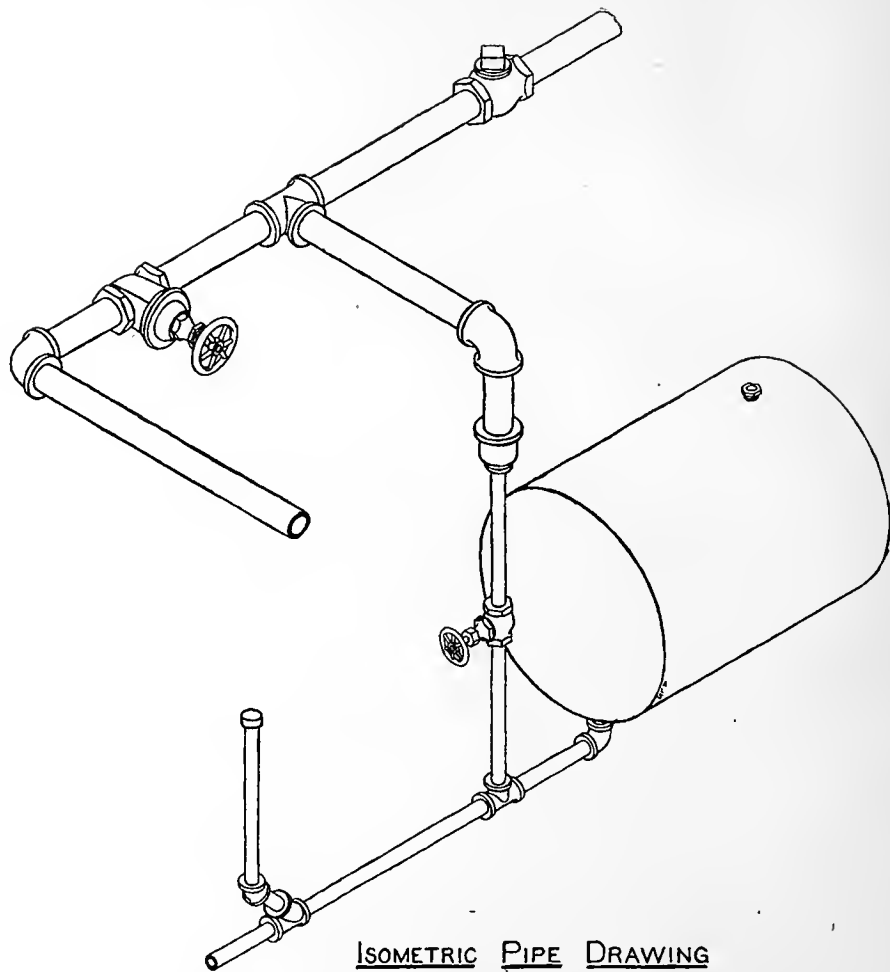

Fig. 12



ISOMETRIC PIPE DRAWING

Fig. 13



though both kinds are used. A common Globe valve is used for a straight run of pipe, an **Angle valve** is used at the junction of two pipes forming an L, and a **Cross valve** is used at the junction of two pipes forming a T. In these valves, the disc which closes the opening is moved parallel to the axis of the opening, while in the Gate valve, the disc is moved perpendicular to the axis.

131. The conventional drawing of a pipe "layout" shown in Fig. 11 may be further simplified by using single lines for the pipe and fittings. A **riser** is a vertical section of pipe. In a sketch of this kind, give distances to center lines of pipe, the size of pipe, name and size of each fitting, kind and size of each valve, cock, drip, lubricator or other apparatus on the line. Where it is necessary to locate valves or fittings exactly, give the dimension along the pipe to the center of the fitting. For an inclined pipe, give the vertical rise in a given horizontal distance. Fig. 13 shows an Isometric sketch of a pipe system. This is made as directed in Sections 259 to 262. Draw first, the center lines of the pipes, then locate on these the center of each fitting as required. Draw outlines of the pipes and sketch in the ends of a fitting first, filling in the body afterward and building it up as usual in making an axometric sketch. In a sketch of this kind, it is not advisable to attempt to follow minute details and dimensions too closely. The proportions of fittings shown in Fig. 12 represent average commercial forms which vary considerably. Note that the diameter of the body of the fitting is approximately the mean of the pipe and the bead diameters. Note conventional designation of a valve at A.

### TAPERED PARTS

132. Tapered arms and hubs of pulleys, sheaves, gears and other wheels are designed for a certain amount of total taper per foot. This taper is usually given on a drawing, however, by specifying the dimensions at the small and large ends.

#### U.S. STAND. FOR PLATE













1		.28125
3		.25
5		.21875
7		.1875
9		.15625
11		.125
13		.09375
16		.0625
18		.05
20		.0375
22		.03125
24		.025
28		.015625

Fig. 14

See Pulley, Fig. 9.

Tapering arms of levers and handles are designated in the same way. See Binder Handle, Fig. 9.

Tapered parts that fit tapered openings are usually specified by giving the dimension at one end and the taper in inches per foot. See Gib Head Key and Cotter in Fig. 10.

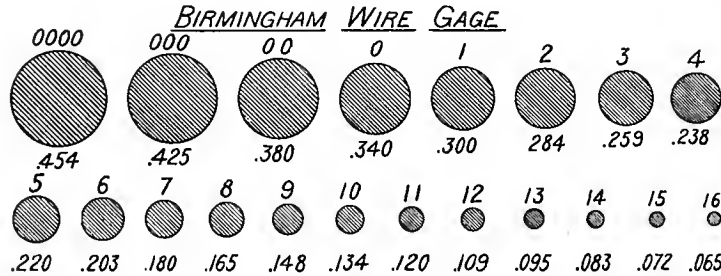

Fig. 15

Taper of centers, tool shanks and pins is designated by giving the diameter of the small end and the taper in inches per foot as measured on the diameter. See Fig. 8, B.

A tapered hole is drilled, turned or bored and reamed. The drill diameter, taper in inches per foot and diameter at the large end are to be given. If some one of the numerous standard taper reamers is used, it should be specified. Thus, No. 3 Morse Taper. Brown & Sharpe tapers are commonly used

in the spindles of milling machines and the Morse taper for the spindles of drills and lathes. The Jarno taper of  $\frac{6}{10}$ " per foot and other special dimensions is being used by some manufacturers. See Table 13 for the B. & S. and Morse tapers.

On account of the confusion regarding the measurement of tapers, many draftsmen prefer to make a supplementary construction showing just how the taper is measured.

## GAGES

133. So many gages have come into use for measuring the various kinds of wire and sheet metals that it requires an expert to keep them properly differentiated. A few of those most useful to the draftsman are given. In order that the sizes may become associated with the numbers, a limited number of plate and wire sections have been given in their actual sizes or as near them as is possible with a printed figure. It should be remembered that the Birmingham Wire Gage is the Stubs' Iron Wire Gage and not the same as the Stubs' Steel Wire Gage. The Twist Drill and Steel Wire Gage is for twist drills and drill rods. It must not be confounded with the many other steel wire gages. See Figs. 14 and 15 and Table 5.

## CHAPTER IV

### TOOTHED GEARING

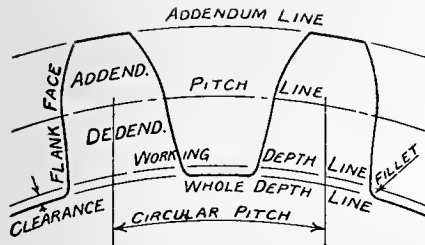

Fig. 16

134. If two cylinders revolving on parallel shafts are pressed together, one will drive the other by friction, if the resistance of the driven cylinder to turning is not too great. With great resistance, slipping will occur and to avoid this, projections may be put on each cylinder with hollows between to accommodate the projections of the other. If these projections and hollows are properly shaped, the result is a pair of toothed gears. The original cylinders are called **pitch cylinders**. In Fig. 16, the **pitch line** or **pitch circle** is the projection of the pitch cylinder. The part of the tooth outside this line is the **addendum** and the part inside, the **dedendum**.

The length of pitch line between centers of two adjacent teeth measured in inches is called the **circular pitch**. The **tooth width** is measured in the same way on the pitch line, as is also the **space width**. Note also the **fillet** and the **clearance**. The **working depth** line shows how near the tops of teeth of a mating gear approach to the bottom of the space. **Face** of a tooth is the working surface outside the pitch line and the **flank** is the working surface inside.

135. Ordinary gears have a whole number of equal teeth and of equal spaces. If the number of teeth on a gear be divided by the diameter of the pitch circle in inches, the quotient is a number called the **diametral pitch**. Thus in the Spur gear Fig. 18, the number of teeth, 16, divided by 2, the number of inches in the diameter of the pitch circle; gives 8, the number of the diametral pitch. This diametral pitch is the one commonly used in designating the gear. It is useful to remember that  $\text{Circular Pitch} \times \text{Diametral Pitch} = \pi$ .

136. The **circular pitch system** of designing gears still survives in the case of heavy power transmission gears with cast teeth. There is no argument in its favor except that it saves the scrapping of large numbers of stock patterns and tooth forms constructed on that system. Of course, any system of

gears tends to perpetuate itself, because generally only one gear of a pair breaks at a time and the owner must replace it with another of the same system or else throw away the remaining good gear. The diametral pitch system will doubtless displace the other in time. The circular pitches in most common use are as follows: From  $\frac{3}{8}$ " to  $2\frac{1}{2}$ " by 8ths, from  $2\frac{1}{2}$ " to 4" by 4ths, and from 4" to 6" by halves.

137. For cut teeth the proportions are as follows.

$$\begin{aligned} \text{Tooth Width} = \text{Space Width} &= \frac{1}{2} \text{ Circular Pitch.} & \text{Addendum Length} &= \frac{1}{\text{Diametral Pitch}} \\ \text{Clearance} &= \frac{\text{Addendum Length}}{8}, & \text{or Clearance} &= \frac{\text{Tooth Width}}{10} \\ \text{Dedendum} &= \text{Addendum} + \text{Clearance} & \text{Fillet Radius} &= \text{Clearance.} \end{aligned}$$

In the case of Cast teeth not machined, the space width exceeds the tooth width by an amount called the **backlash**. This provides for running in spite of irregularities of the teeth.

Fig. 17 shows the actual sizes of gear teeth of the common diametral pitches.

138. Tooth outlines are single curved or **Involute**, as in the Worm Gear, Fig. 18, and Fig. 17 and double curved or **Cycloidal** as in Fig. 16.

139. The dimensions needed on the drawing of any gear are as follows. Dimensions for the pattern-maker, if a casting is used; dimensions to enable the machinist to turn up the **blank**, as the uncut gear is called, and dimensions necessary for selecting the cutter and setting up the work in the machine where the teeth are cut. **Only those dimensions and specifications relating directly to the teeth will be mentioned in considering the following gears.**

### SPUR GEARS FIG. 18

140. Dimensions necessary for teeth are thickness and outside diameter of blank, number, kind and pitch of teeth.

# ACTUAL SIZES OF GEAR TEETH

TABLE OF DIAMETRAL PITCHES AND CIRCULAR PITCH EQUIVALENTS

Diam. Pi.	Cir. Pi.	Diam. Pi.	Cir. Pi.	Diam. Pi.	Cir. Pi.	Diam. Pi.	Cir. Pi.
2	.1571"	5	.628"	12	.262"	26	.121"
2 1/4	.1396"	6	.524"	14	.224"	28	.112"
2 1/2	.1257"	7	.449"	16	.196"	30	.105"
2 3/4	.1142"	8	.393"	18	.175"	32	.098"
3	.1047"	9	.349"	20	.157"	36	.087"
3 1/2	.898"	10	.314"	22	.143"	40	.079"
4	.785"	11	.286"	24	.131"	48	.065"

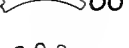
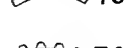
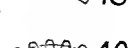
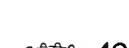
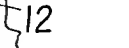
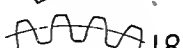
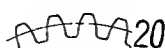
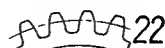
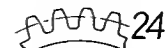
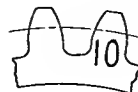
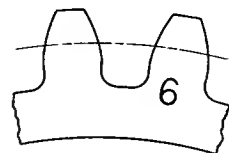
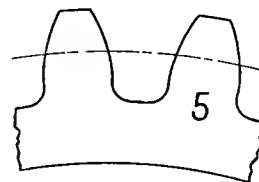
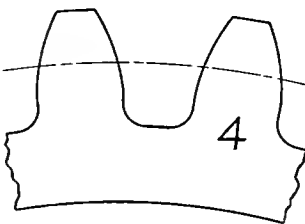
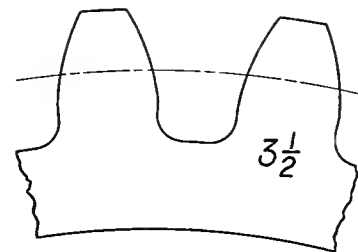
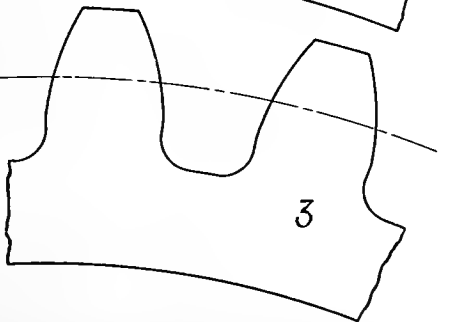
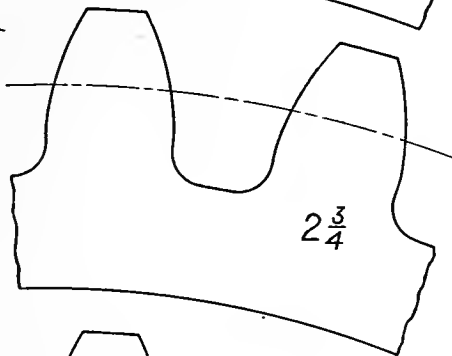
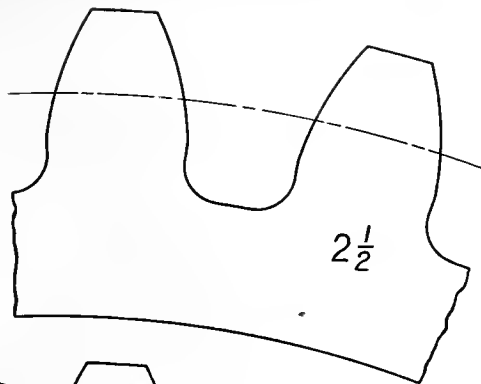
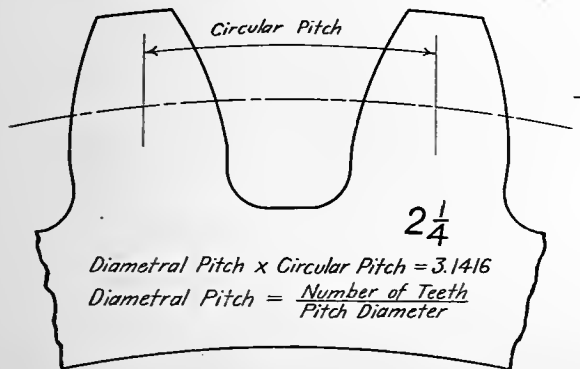
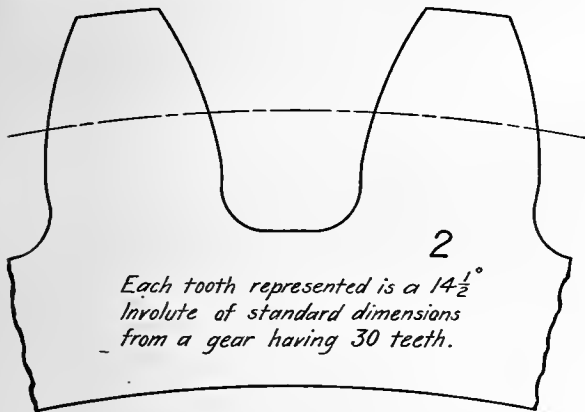

Fig. 17

### RACK FIG. 18

141. A rack is essentially a Spur Gear with an infinite diameter. Give its length and width, the kind and pitch of teeth.

### BEVEL GEARS FIG. 18

142. In bevel gears the pitch surfaces are cones. In the drawing they are shown as isosceles triangles DAB and DBC. The pitch circle on the pitch cone, used for calculations is AB for the small gear and BC for the large, that is, the largest in each.

Considering now the small gear only, note that a tooth tapers from its large end as at UAT toward the vertex, D, of the pitch cone. The dimensions of the large end of the tooth are the ones used in calculations and it should be observed that this large end lies in the surface of a secondary cone whose elements are perpendicular to those of the pitch cone. This cone VAB is called the **back cone**. The pitch diameter of the small gear is its largest pitch diameter i. e. 2". The number of teeth is 20 and the diametral pitch is therefore number 10. The tooth addendum length AT is  $\frac{1}{10}$ " and the dedendum length AU is  $\frac{9}{80}$ ". The various angles and increments may be computed by trigonometry, or by means of Bevel Gear Tables.

Thus, having the pitch radii of the two gears, BZ and DZ, the **center angle** of  $29^{\circ}.75$  can be found. AD can be found as the hypotenuse of the triangle AZD. From AT and AD, find by trigonometry the angle ADT, which added to the center angle gives  $32^{\circ}.58$ . The complement of this angle,  $57^{\circ}.42$  is the **face angle**. From UA and AD determine angle ADU, which subtracted from the center angle gives  $26^{\circ}.55$  for the **cutting angle**. The angle VAZ is called the **angle of the edge** and it is equal to the center angle. The **outside diameter** equals pitch diameter AB, + 2 AT Cos.  $29^{\circ}.75$ . The cutter is selected for 10 pitch and for a number of teeth equal to the number of teeth of the gear, 20, multiplied by  $\frac{AV}{AZ}$ .

To size for teeth, the machinist will need the outside diameter, the **backing**, angle of the edge, face angle, face of blank. For cutting teeth, he will need the number, kind and pitch of teeth, the number of teeth which determines the cutter and the cutting angle.



### WORM GEARING FIG. 18

143. If the teeth on a spur gear are turned slightly so their angle agrees with the thread angle of a screw having the same circular or linear pitch, the two will work together properly and constitute a simple form of Worm Gearing. The thread section of the worm is made like a rack tooth and the relative action of the teeth can be best understood by thinking of the worm as a rack.

If a more extended contact between the thread of the worm and the teeth of the gear is desired, a milling cutter is made which is almost an exact duplicate of the worm. This is run with the worm gear and shapes its teeth. Such a cutter is called a **hob** and when one is used, the teeth of the gear are often first roughed out with a rotary cutter set at an angle to agree with the thread angle. This operation is called **gashing**.

All the dimensions relating to the tooth are calculated, but the outside diameter of the gear may be measured from the pencil drawing. Dimensions should be given in thousandths of an inch.

Dimensions for Worm are, length, outside diameter, root diameter, lead and kind of meshing tooth. If more than one thread is used it should be specified.

Dimensions for Worm Gear are, outside diameter, width and bevel of blank; throat diameter, radius and width of groove; number, kind and circular pitch of teeth; tooth angle should be given if the gear is gashed. Tooth dimensions are based on the fractional diametral pitch corresponding to the given circular pitch and in the usual way. The addendum length in these teeth is equal to  $\frac{1}{4\pi}$  or .07958".

### SPIRAL GEARS FIG. 18

144. If instead of a single thread on the worm used with the worm gear, a large number of threads had been used, then the lead would have been greatly increased and the angle between the thread and the axis of the worm as shown in the projection would have been greatly decreased. The threads on the worm would then appear more like teeth than threads. The tooth angle on the worm gear would have changed accordingly and the result would be two similar gears in which the teeth were portions of threads of very large lead. Such gears are called **Spiral Gears**.



In the case illustrated by the drawing, the center distance between shafts is  $4\frac{1}{2}$ " , the ratio of numbers of teeth on the gears is  $\frac{4}{1}$ , the shaft diameters are  $1\frac{1}{4}$ " and cutters to be used in cutting the teeth are 6 pitch. The necessary dimensions are shown in the drawing. Note that the relation between pitch diameter, pitch and number of teeth is not as in other gears.

**145.** In laying out a pair of spiral gears connecting two shafts at right angles, but which are not in the same plane, there will usually be some fixed conditions such as center distance of shafts, speed ratio of the gears, minimum or maximum diameters of the gears and a limited number of available tooth cutters. It will be necessary to determine first the relation of these various conditions by a consideration of the pair of completed gears shown in Fig. 18.

Let  $S$  = center distance of shafts.

$W_g$  = angular velocity of gear.

$W_p$  = angular velocity of pinion.

$V_g$  = pitch line velocity of gear.

$V_p$  = pitch line velocity of pinion.

$Y_g$  = no. teeth determining cutter for gear.

$Y_p$  = no. teeth determining cutter for pinion.

$R_g$  = radius of gear.

$R_p$  = radius of pinion.

$T_g$  = no. teeth on gear.

$T_p$  = no. teeth on pinion.

$Z$  = diametral pitch of cutters.

$\theta$  = helix angle for teeth of pinion.

Referring to Fig. 18, right hand view, imagine the pitch surfaces of the pinion and gear to be pieces of paper wrapped on the pitch cylinders. Cut the pinion paper on the back side along an element and the gear paper on the front side along an element. Considering the two papers to be held tightly together at the point of contact of the two gears, let the papers flatten out into a single plane which will be tangent to the two pitch surfaces at their point of contact. The appearance of these two papers will be as shown in Fig. 19.

The rectangle A-B is the **developed pitch surface** of the gear, the oblique lines being the center lines of its teeth. The rectangle C-D is the corresponding development for the pinion. The tooth center lines being helixes, become straight lines in the development. Line E-F is the development of part of a helix passing through O, the point of contact of the pitch surfaces. This helix is normal or perpendicular

to the center lines of teeth on the gear and a corresponding helix, HK, on the pitch surface of the pinion, coincides with E-F when that surface is developed. E-F is therefore perpendicular to the developed center lines of the teeth.

The number of spaces on the line A-B equals the number of teeth on the gear and the spaces on the line C-D equal the number of teeth on the pinion. From the figure, it is seen that the number of spaces on E-F and A-B are equal, while the number on H-K and C-D are also equal.

When the front surface of the pinion moves to the right one tooth, or one circular pitch, of the pinion, its component motion along E-F is equal to one normal pitch. This motion causes the back side of the gear to move downward a distance equal to one tooth or one **circular pitch** of the gear and its component motion along E-F is equal to one **normal pitch**.

Therefore

$$\frac{V_g}{V_p} = \frac{\text{Circular Pitch of Gear}}{\text{Circular Pitch of Pinion}} = \text{tang } \theta$$

$$\text{Speed Ratio} = \frac{W_g}{W_p} = \frac{\frac{V_g}{R_g}}{\frac{V_p}{R_p}} = \frac{R_p \text{ tang } \theta}{R_g} \quad \text{and} \quad \frac{W_g}{W_p \text{ tang } \theta} = \frac{R_p}{R_g}$$

$$\text{By composition, } \frac{W_g}{W_g + W_p \text{ tang } \theta} = \frac{R_p}{R_p + R_g}, \text{ but } R_p + R_g = S$$

$$\text{and } R_p = \frac{S}{1 + \frac{W_p \text{ tang } \theta}{W_g}} \quad \text{or Diameter of Pinion} = 2R_p = \frac{2S}{1 + \frac{W_p \text{ tang } \theta}{W_g}} \quad \dots \quad (1)$$

In cutting the teeth, the work is fed in the direction perpendicular to E-F and the width of cut will be one half the normal pitch. The diametral pitch of such a cutter equals  $\frac{\pi}{\text{Normal Pitch}} = Z$ ,

or the Normal Pitch =  $\frac{\pi}{Z}$ .  $T_p$  = the number of teeth on the pinion.

$$\text{Then HK} = T_p \times \text{Normal Pitch} = T_p \times \frac{\pi}{Z}$$

$$\text{CD} = 2\pi R_p \frac{\text{HK}}{\text{CD}} = \frac{T_p \times \frac{\pi}{Z}}{2\pi R_p} = \text{Sin } \theta$$

$$\text{or } 2R_p = \frac{T_p}{Z \text{ Sin } \theta} \quad \dots \dots \dots (2)$$

$$\text{Combining equations (1) and (2), } 2R_p = \frac{T_p}{Z \text{ Sin } \theta} = \frac{2S}{1 + \frac{W_p}{W_g} \text{ tang } \theta} \quad \dots \dots \dots (3)$$

146. Suppose the following quantities are given:

The center distance of shafts—S. The speed ratio— $\frac{W_g}{W_p}$ . The diametral pitch of available cutters—Z.

The angle  $\theta$  should be about  $45^\circ$  for best efficiency, but may be as small as  $12^\circ$  for light work with the gears running in an oil bath. The best range is from  $20^\circ$  to  $45^\circ$ .

The angle  $\theta$  must also be one that will permit cutting the teeth on the milling machine.

The minimum diameter for the pinion will be determined by the size of its shaft and key.

$T_p$  must be a whole number and we see from Fig. 19 that if  $T_p$  is integral,  $T_g$  will be also.

Inspection of equation (3) shows that if S, Z, and  $\frac{W_p}{W_g}$  are fixed, then values for  $\theta$  within its allowable limits must be tried until one is found which when substituted in (3) will give a whole number for  $T_p$  and a satisfactory value for  $R_p$ . Inspection of Fig. 19 will suggest various graphical solutions. The numerical solution is very tedious even when expedited by the slide-rule. Several solutions are usually

possible, but the selected conditions may be such as to give no solution. In the latter case, the construction of a figure like **Fig. 19** will generally show where the difficulty lies.

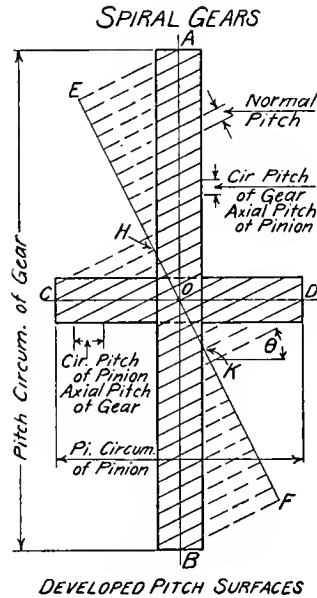

Fig. 19

the gear. For gears with cast teeth, it is needed by the pattern-maker in laying out and setting teeth, when wood patterns are used.

The machinist, in cutting teeth, needs many dimensions not given, such as total depth of cut, addendum length, etc., but these are seldom put on a drawing of the nature here described.

The numerical values for the diameters and tooth angles as given in **Fig. 18** are quoted from, "Worm and Spiral Gearing," by F. A. Halsey, because they were obtained with great accuracy on a calculating machine.

Note that the **tooth angle** is the angle which the tooth helix makes with the axis of the pitch cylinder. It is therefore the complement of the angle commonly given as the **helix angle**, namely, the angle which the helix makes with the plane of the end of the cylinder. The tooth angle as specified in **Fig. 18** is more convenient for the workman, as it is the amount necessary to set over the head of the milling machine for cutting the teeth.

147. It remains to determine the number of teeth for which the **cutter is selected**. It will not be the same for the pinion and gear. For the pinion, it depends on the radius of curvature of the normal helix of the pinion, and for the gear, on the radius of curvature of the normal helix of the gear.

It can be proved easily by geometry, that  $Y_p = \frac{T_p}{\sin^3 \theta}$  and  $Y_g = \frac{T_g}{\cos^3 \theta}$

The student should verify the results given in **Fig. 18**.

148. The pitch diameter is always given on a gear although it may be of no use to the machinist. It is necessary, however, in determining the center distance between the connected shafts, or for checking and computing parts of

149. **Spur gears** are used to connect parallel shafts, **Bevel gears** to connect shafts not parallel, but in the same plane. **Spiral gears** are used to connect shafts not in the same plane and at any angle, **Worm gearing** to connect shafts not in the same plane, but at 90° angle. Bevel gears of the same size connecting shafts at 90° are called **Mitre Gears**. Bevel gears connecting shafts not at 90° are often called **Angle Gears**.

In each case the **velocity ratio** of the pair equals,  $\frac{\text{turns per minute of the driver}}{\text{turns per minute of the driven}}$  equals  $\frac{\text{number of teeth on the driven}}{\text{number of teeth on the driver}}$ . In the case of worm gearing, a thread would be counted as one tooth.

#### REFERENCE BOOKS ON GEARING

150. American Machinist Gear Book—C. H. Logue.	Essentials of Gearing—G. C. Anthony.
Formulas in Gearing—Brown & Sharpe Mfg. Co.	A Treatise on Gear Wheels—G. B. Grant.
Practical Treatise on Gearing—Brown & Sharpe Mfg. Co.	Worm and Spiral Gearing—F. A. Halsey.
Essential Data of Bevel Gearing—E. J. Frost.	Gear Cutting Machinery—R. E. Flanders.

## CHAPTER V

### STRUCTURAL DRAWING

151. Shop drawings of structural details are similar to those used for machine construction, but there are some differences which will be noticed in this chapter. Many of these notes are based on the practice of the American Bridge Company, and the illustrations are in **Figs. 20, 21 and 22**.

There are two common methods of making shop drawings. By the first, the drawing is made so complete that **templets** can be laid out separately on the bench for each individual piece. The Plate Girder, **Fig. 20** is an illustration of this method.

152. By the **second** method, the drawings give only sufficient dimensions to determine the position and length of the main and secondary members, leaving the details to be **worked out by the templet maker** on the **laying out floor**. The Roof Truss, **Fig. 21**, is an illustration of this method. In this case, the **working or gage lines**, U-Y, V-X, X-Y, etc., would be laid out on the floor with chalk lines actual size, for the entire truss. These lines give the lengths and bevels for the different members. For instance the size, shape and rivet spacing for the gusset plate at the joint X can be drawn on the cardboard commonly used for such a templet by reference to the lines meeting at X. The templet for the angle V-X would be laid out in a similar manner by laying it beside the line on the floor and marking off its length and the points for rivets. Such a templet would be made of a long, thin strip of pine one edge of which would be flush with the intersection of outside surfaces of the legs of the angle. The rivet center line or gage line would then be marked in its proper position on the strip, the rivet centers located and holes about  $\frac{1}{2}$ " in diameter bored for each rivet. An angle having been cut to the correct length, the templet would be clamped in position on the outside of the leg to be punched. The workman then takes a prick punch which fits the holes already bored in the wood and prick punches on the angle the center of each rivet. The angle then goes to the machine to have the rivet holes punched. The punch used in this machine has a feeler on the end which, catching the prick punch mark, centers the angle relative to the punch so that the resultant hole is properly placed and with a minimum expenditure of time. Such a punch is shown in an inverted position at K, **Fig. 34**.

153. Though it is permissible to omit the dimensions for locating rivets in a drawing of this kind when the connected parts are shown in place together, such dimensions should never be omitted if the connection is to be made in the field. Thus, in the Roof Truss, the rivet locations are omitted for the gussets, but are given at U for the rivets connecting the end of the truss to the top of the column that supports it.

154. While practice regarding the **application of these two methods** is not uniform, columns, plate girders, heavy lattice girders in buildings and chords, floor beams and stringers in highway bridges are



generally laid out by the first method. Roof trusses, light lattice girders and complicated work such as towers, domes, etc., are laid out by the second method.

**155.** The common **scales** for details are  $\frac{3}{4}$ " and 1" to the foot, but for large plate and lattice girders,  $\frac{1}{2}$ " and  $\frac{5}{8}$ " are used.

**156.** Members are shown as nearly as possible in the positions they occupy in the structure, the **horizontal members horizontal** and the **vertical members vertical**. If, because of lack of space, an inclined or vertical member is shown horizontal, it should have its lower end at the left.

The top view is placed above the elevation. The bottom view is placed below the elevation. The bottom view is a horizontal sectional view as seen from above.

**157.** **Cut parts** are cross hatched if large enough, otherwise they are blackened. If blackened, open holes for field connections are left white. See **Fig. 10** and **Fig. 20**.

**158.** Center lines or **working lines** generally coincide with the rivet gage lines. In **Fig. 21** these would be U-Y, U-X, V-X and X-Y. Some draftsmen use the line of intersection of the backs of legs of an angle for a center line. A few use the line through the center of gravity of the section. Give the distance from the gage line to a finished edge.

**159.** The **bevel** or inclination of one member to another is designated by a right triangle one of whose legs is usually 12" long. The principal use of bevels is in laying out gussets. See **Figs. 21** and **22**.

**160.** Heads of shop **rivets** are shown in the view where they appear as circles and seldom otherwise except for indicating clearance as in the case of the clip angle, **Fig. 22**.

**161.** **Open holes** for field connections are always **blackened** except as noted in Section 157.

**162.** **Conventional Rivet Signs, Fig. 10**, enable the draftsman to avoid covering his drawing with printed notes regarding the heads and points of rivets. They also permit a great saving of time.

**163.** The **dimensions of rivets** commonly used on structural work are given in **Table 14**. In naval construction the diameters range from  $\frac{1}{4}$ " to  $1\frac{1}{4}$ ".



**164.** The location of **rivet gage lines** for the various sizes and shapes of sections has been partially standardized and these are given in **Table 14**. In the case of a line of rivets in a plate, the center line should be located from the finished edge if there be one.

**165.** To provide space for the riveter die, a certain amount of **clearance** between adjacent rivet heads is necessary. These clearances for different sizes of rivets are given in **Table 14**.

**166.** It has been found necessary to limit **the distance between rivet holes** and the distance from a hole to the edge of a plate, for if it is too small, there is danger of fracturing the plate when punching. Thus, the minimum distance between centers of holes is taken equal to three diameters and from the edge of a plate to the center of a rivet as one and one-half diameters of the rivet. These distances are usually slightly exceeded in practice. Those commonly used are given in **Table 14**.

**167.** In a **single row of rivets**, the distance between two consecutive rivets is termed the **pitch**. See for example the end cover plate on the Plate Girder, **Fig. 20**. In a **double row of rivets**, the distance between two consecutive rivets in alternate rows measured parallel to the gage lines is termed the pitch. This is illustrated in the top flange of the Plate Girder, **Fig. 20**.

**168.** In a long row of rivets, it is customary to space them equally or to arrange them in **groups of equal spaces**. When so arranged, the spaces are dimensioned in groups instead of singly, thus, **5 @ 3" = 1'-3"** means that there are five spaces three inches long and that they total a length of one foot and three inches. See Plate Girder, **Fig. 20**.

In case of a double row of **staggered rivets**, they are often specified as follows. **7 alt. @ 4" = 2'-4"**.

**169.** Structural steel shapes are designated as follows:

For an **I Beam** give—depth of web  $\times$  weight per foot  $\times$  length.

For a **Channel** give—depth of web  $\times$  weight per foot  $\times$  length.

For an **H Section**—give depth of web  $\times$  weight per foot  $\times$  length.

For an **Angle** give—length of leg  $\times$  length of leg  $\times$  thickness  $\times$  length.



For a **Z Bar** give—depth of web  $\times$  length of leg  $\times$  thickness  $\times$  length.

For a **T Bar** give—width of flange  $\times$  depth of bar  $\times$  weight per foot  $\times$  length. See Fig. 10.

**170. Gusset plates** are often designated by their thickness only as are those of the Roof Truss. **Fig. 21.** Their size is usually given more completely by the width in inches  $\times$  thickness  $\times$  length in feet and inches of a rectangular plate from which each could be cut. The following are examples.  $15'' \times \frac{1}{4}'' \times 0'-9''$  —  $7'' \times \frac{3}{8}'' \times 1'-0''$  —  $14'' \times \frac{1}{4}'' \times 1'-2''$ . The **length** is commonly taken as the dimension along the principal member to which the gusset is connected.

**171. Rectangular plates** such as **web plates** and **fillers** are designated in the same way as gussets except that the longest dimension is usually taken as the length. See Plate Girder, Fig. 20.

**172. Lattice Bars** are designated thus—width  $\times$  thickness  $\times$  length center to center of holes. See Fig. 22.

**173.** The customary way of putting on **dimension lines and figures** is shown in Figs. 20, 21, and **22.** The chief peculiarity noted is that the figures are placed on the side of the dimension line instead of in a space made by breaking the line. This is rendered necessary by the very small space available for many of the dimension figures. **Note** way of indicating that lengths of angles are approximate in Fig. 21.

In a small size drawing of a part like an angle having thin legs which must be shown by two lines very close together, it is not possible to use heavy lines. To distinguish between the lines of the figure and the extension and dimension lines really requires that the latter be made with red ink. This is particularly true where a blueprint is to be made. In the latter case, by using red ink the dimension and extension lines appear a light blue in the print and are easily distinguished from the white lines of the figure.

#### GAGE LINES RIVET SPACING RIVET DIMENSIONS

**174.** A word of explanation is necessary for **Table 14.** The dimensions there presented are not to be considered as standards which have been universally adopted by construction companies, but rather to represent, as nearly as possible, the prevailing practice. The dimensions of rivets, for instance, will be

found to vary considerably, and there is no agreement among builders as to the minimum rivet spacing. Regarding the latter, it may be said that while the theoretical minimum space between rivets is three times the diameter, and the distance from the center of a hole to the edge of a plate one-half that amount, these rules are not rigidly adhered to in practice. As has already been stated, these distances are usually slightly increased. The distance from the center of a hole to the edge of a plate should be equal to two rivet diameters if possible. The minimum distance may be slightly decreased if the edge referred to is a rolled instead of a sheared one. The clearances given in the table are not so generous as those called for by some builders and should be considered the real irreducible minimum. The dimensions for the gage lines on beams, channels and angles are more nearly standard than those for the Z bars and T bars. The source of each of these tables is specified and the reader can use his own judgment with regard to them.

### DEFINITIONS OF STRUCTURAL TERMS

**175. Angle.**—A rolled piece of steel whose cross section is **L** shaped, It is specified on a drawing as an **L**.

**Apex of a Truss.**—This is the highest point, as Y in the Roof Truss, **Fig. 21**.

**Batten, Stay or Tie Plate.**—A plate used at the ends of compression members to hold the two segments together. See Latticing, **Fig. 22**.

**Bevel.**—The inclination of members to each other. See Roof Truss, **Fig. 21**.

**Bottom Chord.**—The bottom member of a truss, as U-X—, **Fig. 21**.

**Channel.**—A rolled piece of steel whose cross section is **C** shaped. It is specified on a drawing as a **C**.

**Clevis.**—A forked piece with a threaded hole at one end, used for connecting a pin plate to a tie rod. See **Fig. 22**.

**Clip or Clip Angle.**—A short angle used for connecting two pieces. In Clip Angles, **Fig. 22**, a clip is used at A to provide enough rivets to transmit the stress from the gusset to the angle B without unduly enlarging the plate. At C, a clip is used to connect the roof purlin to the top chord of the truss. See also, **Fig. 21**.



- Coping.**—As applied to steel work, this is the cutting of the end of a beam or channel to fit the contour of a beam or channel which it abutts at right angles. See Coped Beam, **Fig. 22**.
- Cotter Pin.**—A pin with a head at one end and with a spring cotter at the other. It is also called a Lateral Pin. See **Fig. 22**.
- Cover Plate.**—A plate riveted to the flange angles of a plate girder to increase the flange area. Also, a plate used to cover a part of a member which would otherwise appear unfinished. Both are used on the Plate Girder, **Fig. 20**.
- Crimped Angle.**—An angle bent so as to produce a slight offset. They are used for web stiffeners and avoid the necessity for fillers. See **Fig. 22** and note the specification regarding rivet spacing. See also **Fig. 20**.
- Eye Bar.**—A rod or bar enlarged at the ends to provide for pin holes. The **ordinary** and the **adjustable** are shown in **Fig. 22**.
- Field Riveting.**—This is riveting which is done outside the shop, often by hand and under conditions which prevent the making of tight joints.
- Filler.**—Material used to fill the space between connected parts so as to preserve the right distance between them. It may be a washer, a ring, a piece of bar or plate or sometimes a block of wood. Note washers between chord angles in **Fig. 21** and plate under the web stiffeners in **Fig. 20**.
- Flange.**—The part of a beam, channel, T bar, etc., which carries the tension or compression stresses. See **Fig. 10**.
- Flats.**—The common commercial designation of rectangular bar stock.
- Gage.**—The distance of a row of rivet holes from some assumed base line. See **Table 14** for gages commonly used for rolled sections.
- Gage Line.**—The center line of a row of rivets on rolled sections.
- Gusset.**—A plate to which intersecting members are attached to form a connection between them. See **Figs. 20, 21 and 22**.
- Hitch Angle.**—Same as clip angle.

**H Section.**—A rolled piece of steel whose cross section is **H**-shaped. It is used for columns.

**I Beam.**—A rolled piece of steel whose cross section is I shaped.

**Lacing or Latticing.**—A zigzag or crisscross arrangement of bars, called **Lattice Bars**, which are used to connect the segments of compression members. Both **single** and **double** latticing is shown in **Fig. 22**. The angles specified in the figure are usually the minimum employed.

**Lug or Lug Angle.**—Same as clip.

**Open Holes.**—Holes left for field connections either rivets or bolts. They are always blackened in the drawing. See Plate Girder, **Fig. 20**.

**Panel.**—The space between two successive chord joints. In **Fig. 21**, the space between U and V constitutes a panel.

**Panel Point.**—The intersection of a secondary member with the chord of a truss. In **Fig. 21**, U, V, Y are panel points.

**Pin Plate.**—A plate riveted to a member and provided with a pin hole which permits a pin connection with an eye bar or with a rod and clevis.

**Pitch.**—Pitch of rivets is the distance between two consecutive rivets of a row measured in the direction of the row. If there are two rows staggered, the pitch is the distance between two consecutive rivets in alternate rows measured in the direction of the row. See **Fig. 20**.

**Pitch of a Roof.**—The pitch or inclination of a roof is expressed by the fraction obtained by dividing the **rise** or height by the **span**. The pitch in the roof truss shown in **Fig. 21** is  $\frac{6\frac{1}{2}}{3'0}$ . The pitches most commonly used are  $\frac{1}{3}$ ,  $\frac{1}{4}$  and  $\frac{1}{3}$ .

**Purlin.**—A purlin is a cross member attached to roof trusses and to which the roof covering is attached. They may be beams, channels, angles or Z bars. See **Fig. 21**.

**Secondary or Web Members.**—These are the members between the top and bottom chords of a truss or girder. In **Fig. 21** they are V-X and X-Y.

**Separator.**—This is a casting formed so as to fit the webs and flanges of two I beams which are placed side by side and is to preserve the spacing between them. See **Fig. 22**.

**Sheared Plate.**—This is long wide plate which has been trimmed to a rectangular form from one with irregular edges.

**Shop Rivets.**—The name for rivets driven in the shop.

**Sole Plate.**—A plate attached to the end of the bottom flange of a girder to insure the distribution of the pressure on the bed plate and support. See **Fig. 20**.

**Splice Plate.**—A plate used for attaching two rolled sections or plates which are butted together endwise so they shall act as one piece. See web splice, **Fig. 20**.

**Stay Plate.**—Same as batten plate.

**T Bar.**—A rolled piece of steel whose cross section is **T** shaped.

**Tie Plate.**—Same as batten plate.

**Top Chord.**—The top main member of a truss.

**Truss.**—A framed or jointed structure designed to act as a beam and whose members are usually subjected to longitudinal stress only, either tension or compression. See **Fig. 21**.

**Universal Plate.**—Plate that is rolled in a universal mill so as to produce finished edges. Such plate is very long and relatively narrow. It is especially adapted for such purposes as cover plates for girders.

**Upset or Upset Rod.**—A round rod enlarged at its ends so it can be threaded without reducing its strength. It is used with nuts, clevises and turnbuckles. See Clevis and Upset, **Fig. 22**.

**Web.**—This is the part of a plate girder, I beam or channel between the flanges and is designed to carry the shear. **Fig. 10**.

**Working Lines.**—These are the center lines used in laying out the parts of a framed structure. They usually coincide with the gage lines. In **Fig. 21**, the working lines are U-Y, U-X, V-X and X-Y. See Section 158.

**Z Bar.**—A rolled piece of steel whose cross section is **Z** shaped.





## PLAN OF BUILDING FIG. 23

**176.** The plan of the Foundry Building shown in Fig. 23 illustrates the salient features of such a drawing. Note the following characteristics. Outside dimensions of the building are given, thickness of walls, center to center location of windows and doors, size of doors, location of columns, posts, partitions, and interior walls. Size of rooms is specified by measurements between the inside faces of walls and the center lines of partitions. The "up" and "down" of stairways is indicated relative to the floor shown. The permanent foundry equipment is also located. The plan presented here contains more details than are usually given.

## CHAPTER VI

### GENERAL SUGGESTIONS ON TECHNICAL SKETCHING

**177.** In instrumental drawing exact measurements are made, but in free-hand work measurements are approximated by the eye and must be largely relative. Dependence on instruments will usually hamper the free-hand draftsman and a sketch that is partly free-hand and partly mechanical is unsatisfactory. It requires but little practice to draw free-hand lines that are fairly straight or parallel and irregular curves are drawn quite as easily as with instruments. A free-hand sketch, if not too complicated, can often be drawn in a quarter the time required for an instrumental drawing and an expert will often make a sketch before the other man can set his compasses.

**178.** Some students draw with a pencil in one hand and an eraser in the other. It is interesting to watch them. They will draw half an inch of a line and immediately erase it, because of real or fancied error. This is entirely wrong. If the line looks wrong, leave it alone and draw another beside it, across it, or any way so it looks right. If this is wrong, let it stand and draw others. An ellipse thus drawn may look like a bird's nest, but the true line can be picked out of the collection, made heavier and the others erased.

Inspection of sketches made by masters will show all this jumble of trial lines which they did not consider of enough importance to erase.

179. Practice at the blackboard where a free arm movement can be had is good training. In drawing a straight line, think of the point to which the line is going rather than about the hand or pencil. Curves may be sketched in, by first spotting a few points in them.

180. To get fair proportions in a drawing, both the relative length and the angularity of the straight lines must be carefully considered. To get proper lengths, let some line of the object be taken as a unit and compare all other lengths with it. Then check by comparison of various related lines. To make these comparisons with celerity, the draftsman should become familiar with the appearance of different fractional divisions of a line. Measurement in eighths is a familiar and useful one as they are easily obtained by continued halving. See line AB in Fig. 24. Thirds, sixths and fifths are also useful. To get thirds, place the pencil at 1 on CD and some other marker at 2; then adjust until the divisions look equal. Sixths are obtained from thirds by halving. For fifths use two markers as at 3 and 4 on EF and adjust until the distance between them is half of each end space. Sevenths are obtained on GH in a similar way, the markers being adjusted till the distance, 5-6, between them is two-thirds of the left end space and equal to the right end space.

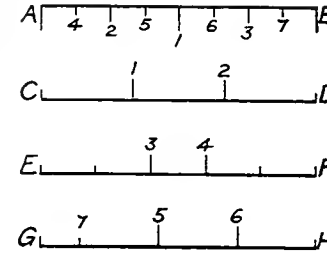

Fig. 24

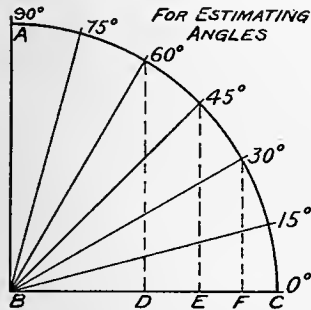

Fig. 25

181. Inclination of a line is generally approximated by comparison with a horizontal; sometimes with a vertical if more convenient. The eye can detect a small error in a right angle and in parallel lines, but for intermediate angles a large error will often pass unnoticed. Great care should therefore be taken with perpendiculars and parallels.

182. For estimating angles intermediate between  $0^\circ$  and  $90^\circ$ , we naturally halve the quadrant getting  $45^\circ$ . This is always readily tested, because it is a rise of one on a base of one as shown in Fig. 25. Another angle familiar to most draftsmen is the  $30^\circ$ . This can be tested by the fact that the short leg F-30 of the right triangle is

most draftsmen is the  $30^\circ$ . This can be tested by the fact that the short leg F-30 of the right triangle is

one-half the hypotenuse B-30. By halving the  $30^\circ$  angle we get the  $15^\circ$ . Another familiar angle is the  $60^\circ$ . Here, the base BD is half the hypotenuse B-60. By halving the angle between  $60^\circ$  and  $90^\circ$  we get the  $75^\circ$  angle. All these angles are in frequent use in engineering work and the student should become familiar with their appearance. With the quadrant divided thus into six equal parts intermediate angles may be approximated with considerable accuracy.

183. If the plane of a square is parallel to the plane of projection or to the picture plane, the corner angles will appear as right angles and the diagonals will bisect them in the drawing just as in the original. If the square is placed so all its edges are oblique to the plane of projection or to the picture plane, its projection will be a parallelogram and its perspective a trapezium. The corner angles of these figures are not right angles and their diagonals do not bisect the corner angles. See **Fig. 41, B**, and **Fig. 3. A**.

184. If the square is placed so one side is parallel to the plane of projection or to the picture plane, then the projection will be a rectangle and the perspective very nearly so.

185. If an angle be placed so its bisector is parallel to one of the planes of projection, then the projection of the angle on that plane will be bisected by the projection of the bisector.

186. It is therefore very important to remember, that in constructing figures whose planes are not parallel to the plane of projection nor to the picture plane, no use can be made of the actual angle between adjacent edges.

187. A triangle should be constructed by drawing its base, its altitude, its vertex and last the oblique sides. To locate the altitude properly, note how it divides the base line.

188. In the equilateral triangle, **Fig. 26**, the altitude bisects the base. Note that the altitude is approximately equal to  $\frac{7}{8}$  of the base. The vertices of the concentric triangle are on the altitude lines. To construct the triangle draw BC, mark its middle point D, draw AD, locate A and draw AB and AC. This completes ABC. To construct FGH, measure off DE as a fractional part of AD, draw FG parallel to BC, draw altitude CK and BL, locate F and G and draw FH and GH parallel to AB and AC. Or FH and GH may be located in the same way as FG, if the preceding construction gives poor results.

189. In the regular hexagon, Fig. 27, the short diameter, FH, is approximately  $\frac{7}{8}$  of the long diameter, AB. A side is equal to  $\frac{1}{2}$  AB and the lines FH and GJ bisect AC and CB. The vertices of the concentric hexagon are on the diagonals of the outer figure.

To draw the outer hexagon, draw AB, halve it, quarter it and draw FDH and GEJ. Locate F and H, draw FG and HJ parallel to AB. Draw last AF, AH, BG and BJ, then check by noting if opposite sides are parallel and equal to one-half their parallel diagonal. The base of the nut in Fig. 45 K, was drawn in this way.

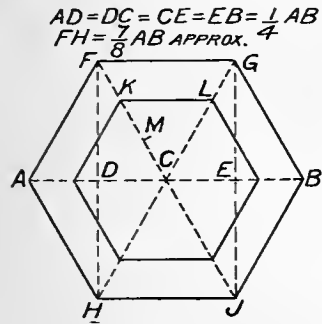

Fig. 27

approximately to  $\frac{7}{10}$  of the half diagonal. To draw the circle, mark its center and spot four points as E, F, G, and H equidistant from it. These points are needed not so much to produce a good curve as to insure its proper location and size. For the concentric circle, similar points may be taken, the distance between the two curves being measured on a radius and as a fraction of the large radius. Thus in the figure this distance is  $\frac{1}{3}$  of the large radius.

192. Suppose a circle is placed so its plane is oblique to the plane of projection, or to the picture plane. It may be proved that its projection, or its

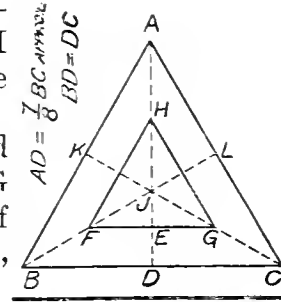

Fig. 26

190. Rectangular figures are constructed without difficulty by drawing their sides directly. Their diagonals intersect at the center.

191. After the rectangle, the circle is the commonest figure with which the draftsman has to deal. If it is remembered, that it can be inscribed in a square, it will be easier to draw, whether it is shown as a true circle or as an ellipse.

In Fig. 28 a circle is shown inscribed in a square. It touches the sides at the middle points. It cuts the diagonals at a distance from the center equal

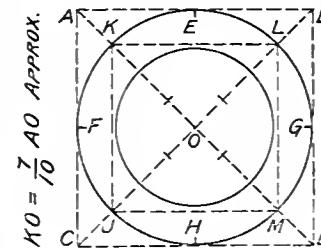

Fig. 28

perspective is an ellipse. The circle has an infinite number of diameters and one of them will be parallel to the plane of projection and project in its true length. This will be the longest diameter of the ellipse, or its **major axis**. In the same way, one of the diameters will project shorter than any of the others and this will be the shortest diameter, or **minor axis** of the ellipse. These two axes are perpendicular in the ellipse and the curve is symmetrical with respect to each.

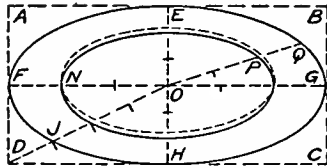

Fig. 29

**193.** The projection of the concentric circle will give an ellipse similar to the first. For instance if the radius of the second circle is  $\frac{2}{3}$  that of the first then each radius of the inner ellipse will be  $\frac{2}{3}$  of the coincident radius of the outer ellipse. This is shown in the full lines of **Fig. 29**. Thus  $ON = \frac{2}{3} OF$  and  $OP = \frac{2}{3} OQ$ .

**194.** Returning to the circle described in Section 192, suppose a line be drawn perpendicular to the plane of the circle at its center. This line will be perpendicular to every diameter of the circle, therefore perpendicular to that one which is parallel to the plane of projection and which projects as the major axis of the ellipse. By the principle stated in Section 184, **the projection of the line perpendicular to the plane of the circle will be a line perpendicular to the major axis of the ellipse.**

This is one of the most important principles relating to the projections or perspectives of cylindrical forms and its common violation, through ignorance, results in disagreeable distortions.

From this principle, it follows that **a circle whose plane is horizontal will be represented by an ellipse whose major axis is horizontal.**

**195.** The principles explained in Sections 191, 192, and 194 apply to correct perspective drawings as well as to projections. In the case of concentric circles the perspective representation is slightly different. The inner circle is shown as an ellipse, but its center does not coincide with that of the outer ellipse. This is shown by the dotted lines in **Fig. 29**. The plane of the circle is below the eye.

**196.** A square circumscribed about the circle of Sec. 192 will project as a parallelogram. The ellipse, the projection of the circle, will touch the middle points of the sides and have its center at the intersection of the diagonals.

197. The major axis should always be drawn or imagined when drawing an ellipse and the curve should be made symmetrical on it. Having both axes given, mark the center of the ellipse and then spot points for the four ends of axes. Draw the curve through these four points.

198. Referring to **Fig. 46, B**, let the plane of the circle partly shown by the arc HLK be parallel to the plane of projection. Let equal divisions be marked on it as indicated. Now revolve the circle on a line, CH, coincident with its diameter, until it projects as the ellipse of which one-half is SHJ. Any division point as L on the circle will, during the revolution, remain in a plane perpendicular to the axis and the projection of L will be found somewhere on a line LM perpendicular to CH. As the projection of L must also be on the ellipse, it will be found at M.

It is seen, that equal divisions on the circle are not so on the ellipse, its projection, but that they shorten gradually toward the end of the major axis. This construction will give results of considerable accuracy, even though drawn free-hand. When some knowledge of the rate of shortening is acquired, the construction may be dispensed with. The gear teeth in the drawing were spaced by the eye and not quite accurately, as the construction shows. It is true, however, that the error is scarcely noticeable.

199. Having a circle and one of its diameters, if a chord be drawn parallel to the diameter and bisected, a diameter through the point of bisection will be perpendicular to the first diameter. Now place the circle so its plane is oblique to the plane of projection and the projection of the circle becomes an ellipse. The diameter and parallel chord project as parallels and the chord is still bisected. The projection is shown in **Fig. 30**.

Having an ellipse ABCD representing a circle, and a line, 1-2 representing a diameter of that circle, to find the line representing a diameter perpendicular to 1-2, construct as follows. Draw a chord 3-4 of the ellipse parallel to 1-2, bisect it at 5 and draw the required line 6-7 through point 5 and O, the center of the ellipse.

200. The draftsman should acquire familiarity with the shapes of various ellipses. Several should be constructed accurately by the method shown in **Fig. 30**. Draw two lines AB and CD at right angles

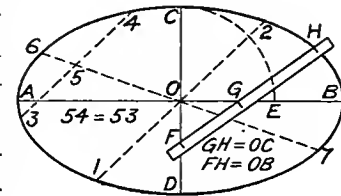

Fig. 30

and intersecting at O. On the straight edge of a strip of paper or card, mark FH equal to half the desired major axis and GH equal to half the desired minor axis. Place the paper so that F falls on the line COD and so G falls on the line AOB, then move the paper about, keeping F and G always on their respective lines. Mark point H on the drawing at its various positions and connect them. The curve will be an ellipse.

**201.** Irregular figures are best drawn by plotting as shown in the line RS Fig. 49. Select a base line 1-11 and divide it into equal parts. Erect a perpendicular or ordinate at each division point and measure off on it the required distance.

## CHAPTER VII

### SKETCHES FOR SHOP DRAWINGS AND ELECTRICAL SYMBOLS

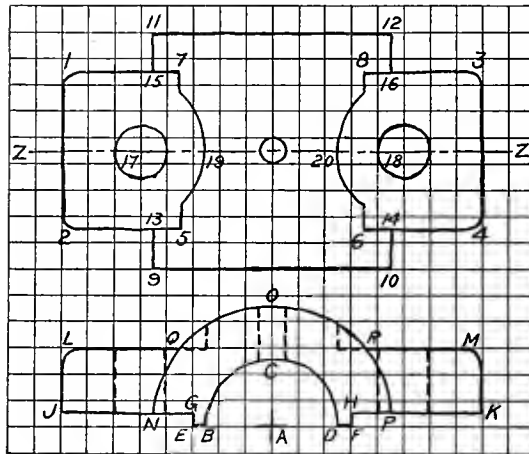

Fig. 31

then proceed to the top view. Draw center line Z-Z, then 1-2 and 3-4. By referring to the lower view, spot points 5, 6, 7 and 8 and draw in order 1-7, 8-3, 2-5 and 6-4. By referring to the lower view,

**202.** If it is desired to have a sketch accurate as to shape and size, it should be made on cross section paper. The kind ruled in  $\frac{1}{8}$ " squares is preferable, though that ruled in  $\frac{1}{4}$ " squares is suitable for large drawings.

If the piece has one or more axes of symmetry, these should be drawn first as center lines. If the piece has any prominent circular parts, the view showing them as circles should be drawn first. Thus, in Fig. 31, the lower view of the box cap is the one to be started first. The dimensions being given and the scale of the drawing being assumed as half size, draw a horizontal and a vertical center line through point A. Take the radius of the shaft and spot points B, C, D. Draw the semicircle BCD. Draw in succession BE, DF, GE, HF, JG, PK, LJ and MK. Spot points O, N and P, and draw arc NOP. Draw LQ and MR,



spot points 9, 10, 11 and 12 and draw in order 9-10, 11-12, 9-13, 11-15, 10-14 and 12-16. Spot centers of bolt holes 17 and 18 and draw circles. Spot 19 and 20 and draw arcs concentric with the bolt holes. Draw verticals at 5, 6, 7 and 8 to meet these arcs. Draw circle for oil hole.

Return to front view and by projecting vertically from the top view, put in dotted lines for bolt and oil holes and the recesses cut for the nut.

The order of drawing lines may be varied to some extent, but that given will enable the draftsman to do the work expeditiously and **in ink without previous penciling**. This is the kind of sketch which a designer most frequently uses in working out details.

**203.** If the draftsman has to make a dimensioned sketch of a piece in place on the machine, a different procedure is advisable. The piece should be sketched, dimension lines and specifications added before any measurements are made. The purpose of this is to avoid soiling and obliterating the drawing as much as possible. There is little advantage in making such a sketch on ruled paper, as the drawing is made by the eye.

The piece to be sketched is the Rocker Arm shown in **Fig. 32**. It is covered with dirt and grease and cannot be removed from the machine. Before beginning the sketch, look the piece over carefully to determine its character.

Draw first the view showing the hubs as circles. Put in center lines X-X and Y-Y the angle between them being estimated by the eye. Spot centers of circles and draw all six beginning with the large hub. In estimating relative sizes, base the diameter of the large hub on the distance between its center and the left hand center. Base the diameter of the small hubs on the diameter of the large one. Base the diameter of each hole on its own hub diameter. Next draw lines of arms basing the arm width on the small hub diameter. Proceed to the lower view, put in the center line Z-Z and vertical center lines for the holes. Mark on vertical center lines the lengths of hubs basing the measurement on the hub diameter. Draw ends of hubs, determining their side limits by reference to the upper view. In the same way, spot and draw the lines of the arms, basing their thickness on their width. Draw the vertical side lines of the holes and hubs. The arms being filleted into the hubs, there will be no intersection line, but the shape of the

joint may be suggested by a line, as shown in the drawing. By showing one-half the front view in section, the construction is seen at a glance, otherwise, dotted lines must be used. Draw the outline of the arm section. Little draft is necessary on the hubs as they are short.

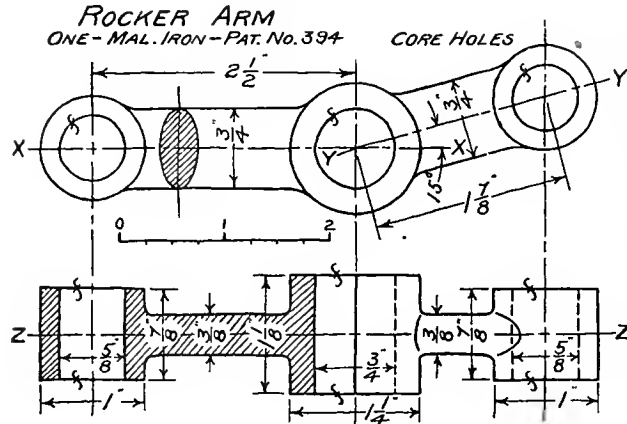

Fig. 32

Next draw extension and dimension lines, but put on no figures. Make the measurements systematically, so none may be overlooked. The following order is satisfactory: Distance between centers of hubs; Angle of arms; Diameter and length of each hub and hole; Width and thickness of each arm. Put on dimension figures distinctly and mark finished surfaces in the view where the surface projects as a line. Make the section lining last. Specify material, number required and the pattern number, if there be one.

204. If dimensions are known, and a sketch is to be made with some accuracy as to proportions, a scale can be improvised as shown in the drawing, if neither scale nor ruled paper are available.

205. If sketches like the preceding are made in the systematic way indicated, they may be drawn directly in ink. **The beginner should work with ink from the start**, as it trains him to look ahead and plan his drawing. He may spoil a few drawings at first, but a spoiled drawing is usually one of the most instructive lessons a draftsman ever gets.

### CHECKING A WORKING DRAWING

206. Even with the utmost care an error in a drawing will sometimes get by the checker and appear in the finished machine or structure. Such errors may often be remedied, but sometimes they prove very costly. All reasonable precautions to avoid them should be taken. Not all drafting offices check their drawings, but most of them admit the desirability of doing so.

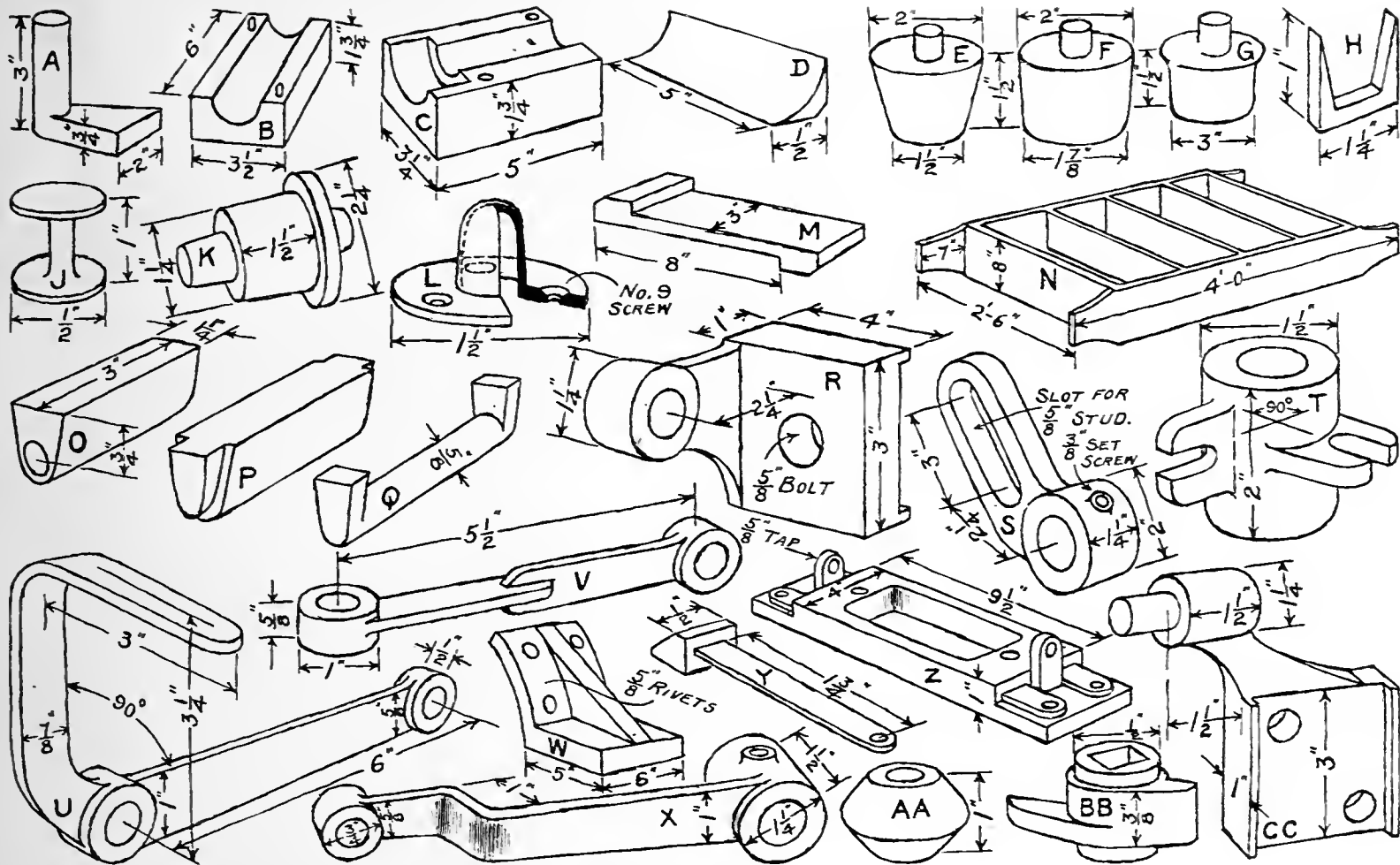

Fig. 33

No general brief rules can be laid down for checking a design as so many things have to be considered. A few things that easily creep in unnoticed are as follows: Interference of parts, as might happen with the feed handles on a lathe carriage; Holes that cannot possibly be drilled; Tee slots which the cutter cannot get into; Surfaces which a planer tool cannot reach; Castings with impossible coring.

In checking a drawing, we shall examine to see if there are sufficient dimensions and specifications and if they are the right kind to secure correct construction. Important dimensions, such as center distances, should be scanned more carefully than others. Also we must compare corresponding dimensions of related parts to see if they agree. Thus the bearing on a spindle must agree with the bearing in the box. The diameter and pitch of a screw must agree with the same dimensions on the hole into which it goes.

The logical method is to take each piece by itself and putting yourself in the place of the workman go rapidly in imagination through each step in the process of making. Examine systematically the location, dimensions and specifications of each part of a piece. Where overall dimensions are given, see that they agree with the sum of the partial dimensions. Compare dimensions of fitted parts with the corresponding dimensions of the related piece. See if finish marks are complete, also if material, number required and any special treatment is specified.

To illustrate, take the Spur Gear in Fig. 18. Is it cast or cut from the solid bar? Are dimensions for the pattern maker complete? Look for blank diameter, face width and bore. Is the finish fully specified? Are the dimensions for the machinist complete? He will first chuck and ream a 1" hole, then he will put the blank on an arbor, turn it to  $2\frac{1}{4}$ " diameter, and face up the sides to  $\frac{7}{8}$ " thick. The teeth will next be cut. How many? for setting the index. What number, kind and pitch of teeth? for selecting the cutter. The arbor is now knocked out and the keyway cut on the keyseater. What is its size? Where is the shaft on which this gear is to be keyed? Is the bearing for the gear 1" diameter and  $\frac{7}{8}$ " long and is there a  $\frac{1}{4} \times \frac{1}{4}$ " key? These questions satisfactorily disposed of, the drawing may be considered checked.

Many variations of this method of checking will be found desirable depending on the type of work considered. It should be done always systematically to insure that every item is covered. If there are tapped holes, all might be considered at one time, examination being made for location, diameter, pitch and depth.

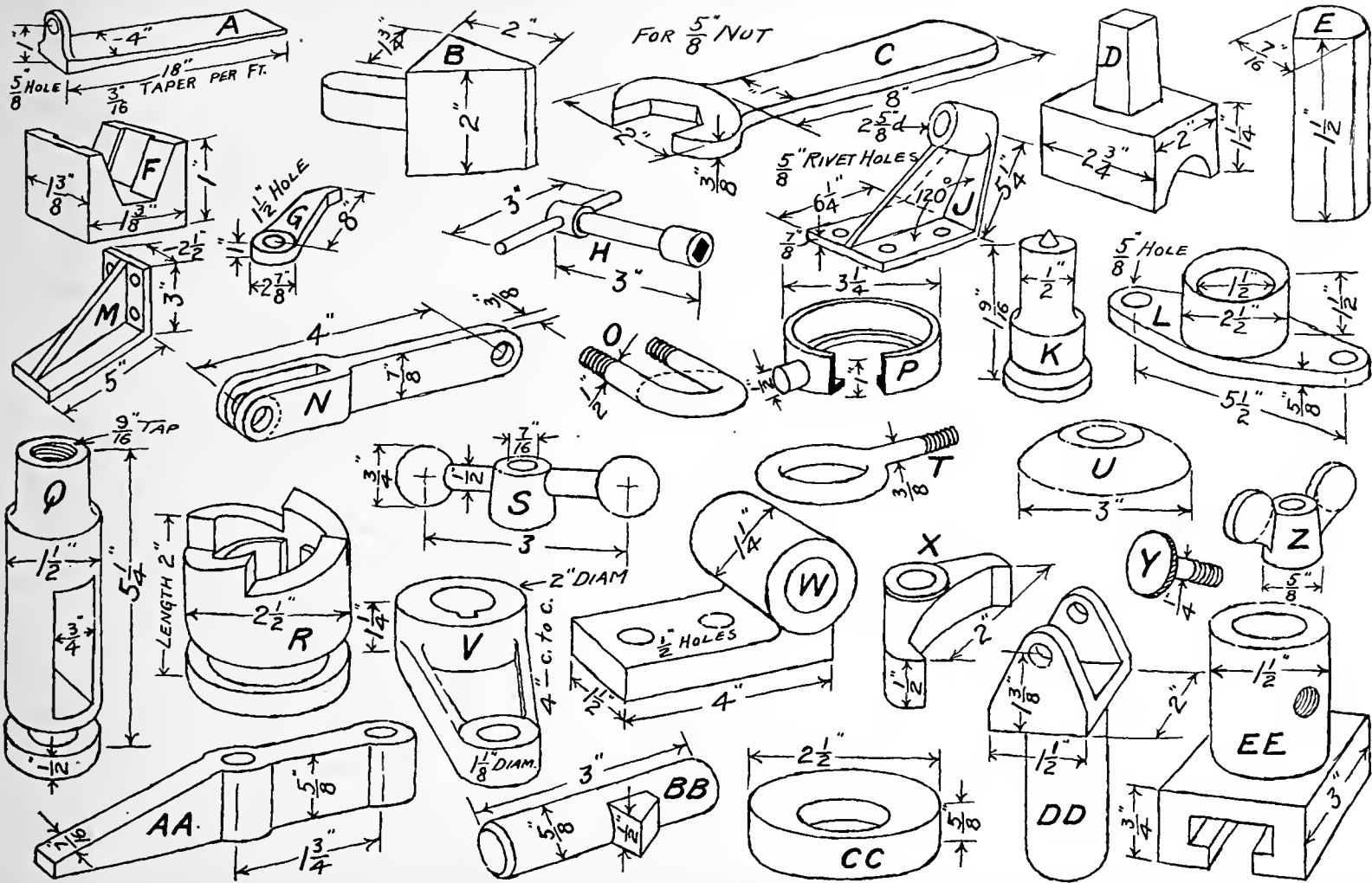

Fig. 34

## EXERCISES ON SHOP SKETCHES.

207. The following exercises have been selected to give practice in the making of rapid shop sketches. The objects should be sketched to some suitable scale, with ink, on cross section paper without previous pencilling. Where dimensions are lacking, supply them, taking them of such size as will agree with the general proportions of the given figure. The exercises are arranged in groups which increase in difficulty and selections should be made from all the groups.

1. Make a side view of each of the following objects shown in Fig. 47. Rectangular Frame A.—Triangular Prism B.—Regular Hexagonal Prism C.—Square Pyramid D.—Hexagonal Pyramid E.—B, C, D and E with part above plane x—x removed.—Oblique Cone K.—Sheet metal Transition Connection N.—Sheet metal Boot O.—Three way Pipe P.—Hood Q.

2.—Make a top view of—A7, Fig. 9.—A5, Fig. 9.—From Fig. 48, Angle Journal Box A.—Rod Rest B.—Scale Weight K.—Boiler Patch Bolt L.—Half Box M.—Stirrup V.—Bracket Y.

3.—Make a sketch of the section cut by the plane x—x from each of the following in Fig. 47.—B, C, D and E.—Make a sketch of the section perpendicular to the spindle and through the oil hole in B, Fig. 8.

Note.—In the following groups make working projection sketches with complete dimensions and specifications.

4.—Bracket M, Fig. 34.—Jaw F, Fig. 34.—Bench Hook M, Fig. 33.—Center Rest Jaw, Fig. 44.—Post, H, Fig. 52.—Flask Cope N, Fig. 33.—Blacksmith's Hardie B, Fig. 34.—Pinch Dog H, Fig. 33.—Gib Head Key, Tab. 6.—Block with T Slot, Tab. 10.—Several feet of an I Beam,—a Channel,—an Angle,—a Z Bar,—a T Bar, Tab. 14.—Lattice Bar, Fig. 22.—Conveyor Bucket D, Fig. 48.

5.—Fillister,—Countersunk,—Button head Cap Screws, Tab. 3.—Stud, Tab. 4.—Machine Screws, Tab. 5.—Button,—Cone,—Countersunk head Rivets, Tab. 14.—From Fig. 33, Cope Core Print E,—Nowell Core Print F,—Pattern Hub G,—Pattern with Prints K,—Chaplet J.—From Fig. 34, Punch K,—Thumb Screw Y.—Machine Knob, Tab. 7.—Machine Handle, Tab. 9.—Cotter Pin, Fig. 22.

# SYMBOLS FOR ELECTRICAL DIAGRAMS

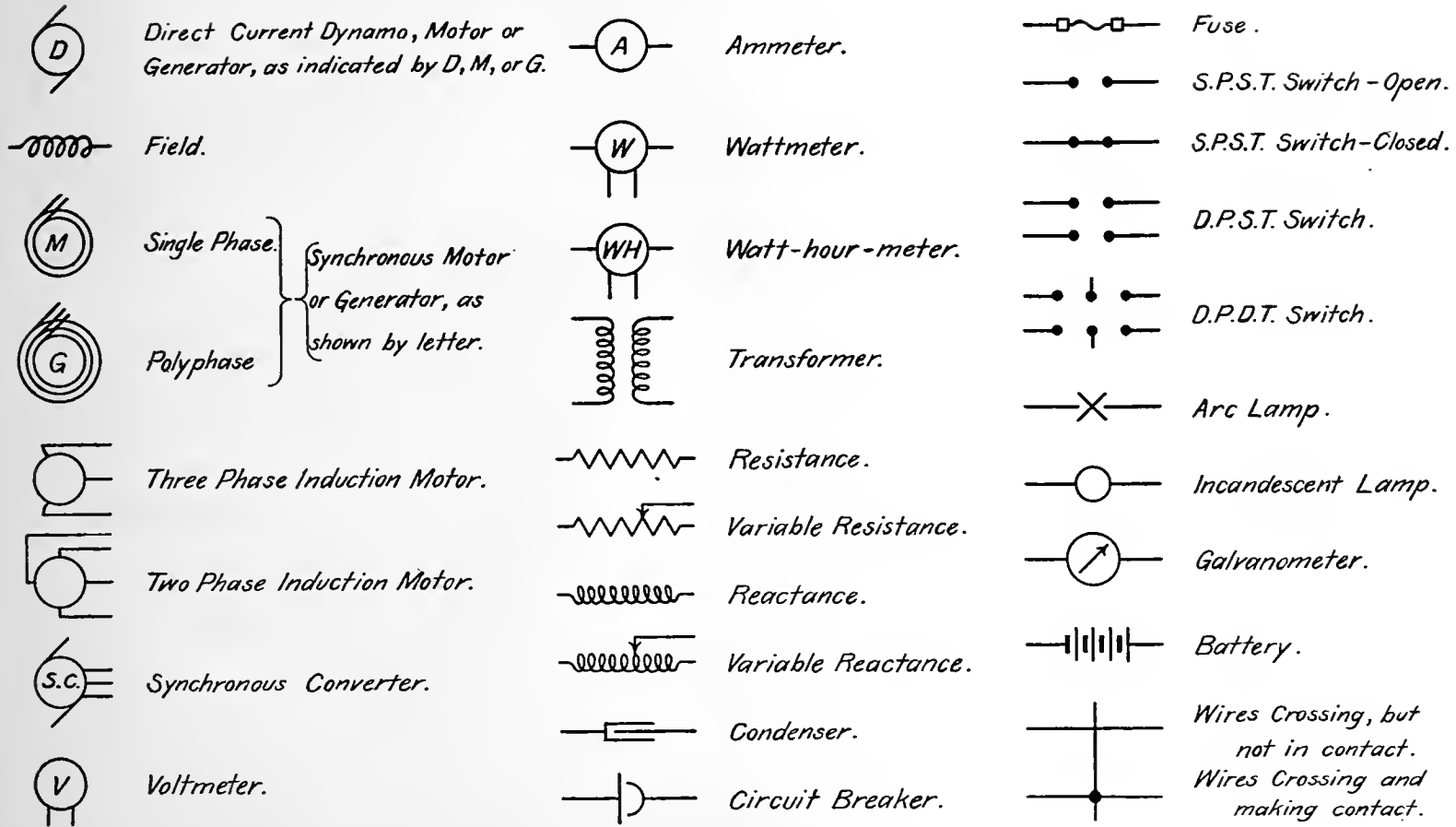

Fig. 35

6.—Punched Washer, **Tab. 9.**—Washer N, **Fig. 45.**—Washer H, **Fig. 48.**—Plain Shaft Collar, **Tab. 19.**—Conical Roll AA, **Fig. 33.**—Box on B, **Fig. 8.**—Face Plate B, **Fig. 8.**—Cam E, **Fig. 48.**—Flange G, **Fig. 45.**

7.—Bolt and Nut, **Tab. 1.**—Square and Hexagonal head Cap Screws, **Tab. 2.**—Set Screw, **Tab. 2.**—Collar Screw, **Tab. 4.**—Eye Bar, **Fig. 22.**—Clevis, **Fig. 22.**—Reducing Bushing N, **Fig. 11.**—Box Cap R, **Fig. 45.**—Drill Stop, **Fig. 50.**—Solid Journal Box, **Fig. 51.**—Separator, **Fig. 22.**—Rod Rest, B, **Fig. 48.**—From **Fig. 33,**—Pocket Core A,—Plain Core Box B,—Balanced Core Box C,—Fillet D,—Metal Dowell L,—Cored Casting O,—Pattern and Prints P,—Core Q,—Loom Bracket Box R,—Twisted Link V,—Latch Y,—Pillow Block Shoe Z,—Loom Bracket CC.—From **Fig. 34,** Taper Gib A,—Wrench C,—Bottom Swage D,—Knife Edge E,—Ratchet Pawl G,—Stuffing Box Gland L,—Forked Link N,—Cap Ring P,—Tool Post Q,—Clamp Handle S,—Crank Arm V,—Solid Journal Box W,—Clamp Jaw AA,—Wrist Block EE.

8.—Flanged Tee V, **Fig. 11.**—Safety Collar, **Tab. 19.**—Latch Handle A, **Fig. 8.**—From **Fig. 33,** Offset Slotted Arm S,—Tumbler T,—Bent Lever U,—Boiler Lug W,—Offset Link X,—Tumbler BB.—From **Fig. 34,** Socket Wrench H,—Angle Bracket J,—Staple O,—Jaw Clutch Coupling R,—Eye Bolt T,—Double Pawl X,—Wing Nut Z,—Forked Post DD.—Tailstock U, **Fig. 22.**

9.—Solid Journal Box, **Tab. 17.**—Pulley, **Tab. 20.**—Spur Gear, **Tab. 20.**—Rigid Pillow Block, **Tab. 18.**—Angle Pillow Block, **Tab. 19.**—Flange Coupling, **Tab. 16.**—Compression Coupling, **Tab. 17.**—Jaw Clutch Coupling, **Tab. 15.**

10.—Plan of a room with location of doors, windows, radiators and other prominent fittings.

### ELECTRICAL SYMBOLS FIG. 35

208. To facilitate the rapid sketching of plans for wiring, some system of symbols for the parts occurring most frequently is often useful. The ones given here in **Fig. 35** have been adopted by the Electrical Engineering Department of the Worcester Polytechnic Institute. Their application is illustrated in **Fig. 36.**



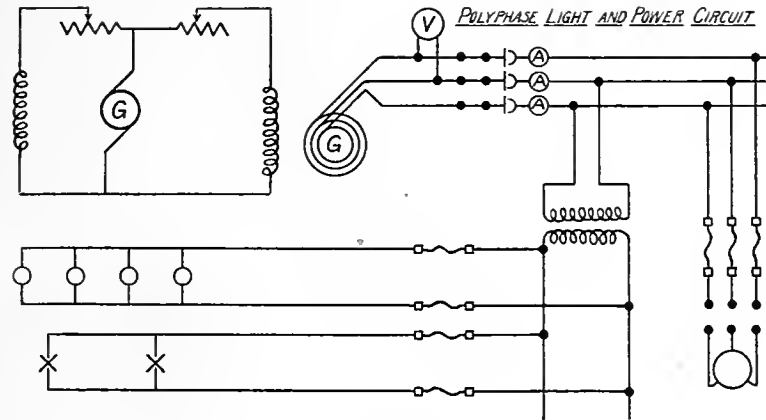

Fig. 36

## CHAPTER VIII

### GEOMETRIC PERSPECTIVE AND ARTISTS' PERSPECTIVE

209. The method of making a Geometric Perspective drawing has been described in Chapter I. It was there pointed out, that such a drawing should be viewed from a particular point only, if it were to correctly represent the object.

If one stands with his back against a wall, his arms outstretched on it and his eyes looking straight ahead, it is possible to detect motion of the hands. But though the **angle of vision** may be  $180^\circ$  or more, the angle of distinct vision is certainly very small. In reading from a page held at the usual distance, the eye can see distinctly the word at which it is looking and indistinctly the word on either side. Beyond this, the ordinary eye does not see words distinctly enough to read them and has to be turned.

If then, we are examining a long drawing, we do not stand close to it at its middle and turn the eyes or head so as to get an oblique view of its ends, but we move about and stand in front of each detail to

be examined. It is for this reason, that geometric perspective drawings, so made that the eye embraces a large angle, are distortions offensive to the eye. Such a drawing would appear correct and without distortions if viewed from the right point, but it would be difficult to locate this point for an observer and it would be an unnatural and unsatisfactory way of looking at the drawing.

Referring to **Fig. 4, A**, it is impossible for the human eye to see the front face of a cube as a perfect square and at the same time see the top and side faces. If the cube is placed so one face is seen as a perfect square, no other face is seen and if the cube be turned sufficiently to show a top and a side face also then the front face changes its shape, the top and bottom edges becoming inclined.

Neither do we ever see a horizontal circle as a tilted ellipse, and the apparent shape of a sphere is always a circle.

The photographic lens gives a true geometric perspective image and if on account of confined space, it is necessary to use what is called a "wide angle" lens, these distortions may become very great. We shall find in such photographs many curious representations, such as a sphere appearing as an oval solid similar to a hen's egg. This is due, it should be remembered, not to any defect in the lens, but to the geometric perspective. The eye could see a sphere the same way, if the angle of distinct vision were great enough.

**210. Artists' Perspective** shows an object as the eye sees it. Its results are similar to what would be obtained, if a spherical surface were used for the picture plane in a geometric perspective, the eye being placed at its center. As only a very small portion of such a surface may be considered approximately flat, the angle of vision is of small size. A panoramic photograph is a near approach to an artists' perspective, but inspection of one of these, shows new misrepresentations. The perspective is violated seriously in the matter of convergence of lines.

It is therefore the province of the artists' perspective to harmonize all these incongruities and produce a drawing which, though not scientifically correct, produces a pleasing and satisfactory effect on the eye.

**211.** We have seen in Chapter I, that a projection drawing is simply a perspective made with the eye at a great distance from the object.

We have also noted the following facts about projection, namely.

Lines oblique to the plane of projection do not project in their true lengths, but are **foreshortened**.

The angle between two lines does not project in its true size, except under certain peculiar conditions.

The projections of parallel lines are parallel.

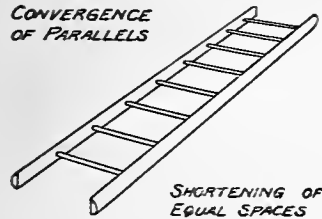

Fig. 37

Equal divisions on a straight line will project as equal divisions.

Lines parallel to the plane of projection project in their true size and shape.

Equal and parallel figures project in equal and parallel figures, though not the same as the original.

It remains, to discover how these results will be changed, when the eye is brought close to the object.

212. The following principles are based on observation, but they may be proved by geometry. The **line of sight** is the line along which the eye looks at the object, just as in aiming a gun. The **picture plane** is always perpendicular to the line of sight.

213. In Fig. 37, is shown a ladder lying on the ground. Observe that lines which are parallel in the object, converge in the drawing. Fig. 44 shows the effect of non-convergence

214. Comparing the convergence of the rungs with the convergence of the sides of the ladder, observe that the nearer lines are to being parallel with the line of sight, the greater their convergence.

215. Parallels which are perpendicular to the line of sight show no convergence and if equal in length, the one furthest from the eye appears shortest.

216. **Exception.** Though vertical parallels may appear to converge, they never are drawn so. See Section 6, and Fig. 3.

217. In Fig. 38 is a Geometric Perspective drawing of a regular hexagon resting flat on a horizontal plane. Two opposite sides and their parallel diagonal constitute a series of parallel lines. There are thus three series, each having its own direction. Note that the lines of each series converge toward the same point. This point is called the **vanishing point** of the series, because if the lines were unlimited in length,

they would disappear at that point in the drawing. This may be seen on a long, straight stretch of railroad track.

218. Note in Fig. 38 that the three vanishing points for the sides and diagonals are on the same horizontal line.

All series of parallel lines which are parallel to the horizontal plane will have their vanishing points on the same horizontal line. This is called the **Horizon Line**.

219. Notice in Fig. 37, that though the rungs of the ladder are equally spaced, those furthest away appear closest together.

If a straight line is divided into equal parts, those parts furthest from the eye appear shortest and the length gradually increases as they get nearer the eye.

This may be seen in the spacing of ties on the railroad and on a picket fence.

220. Fig. 39 is a drawing of three equal pulleys on a shaft. Note the difference in the shapes of the ellipses.

In a series of circles, the one whose plane is parallel to the line of sight appears as a straight line, the one whose plane is perpendicular to the line of sight appears as a true circle, while circles having intermediate positions appear as ellipses with varying degrees of narrowness. This principle applies to other figures as well as to circles.

It may be seen illustrated in long cylindrical forms such as boilers, tanks and pipes.

221. With the exception of the variations stated in Sections 213 to 220 inclusive, the principles of projection drawings apply equally well to perspective drawings.

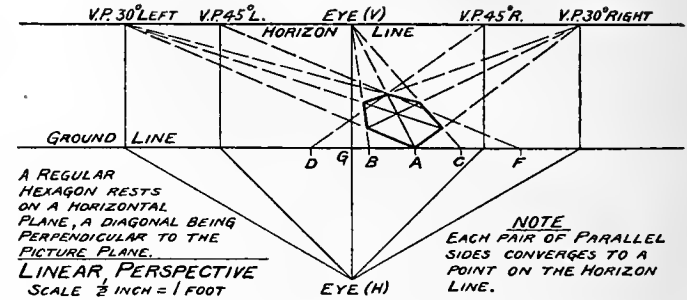

Fig. 38

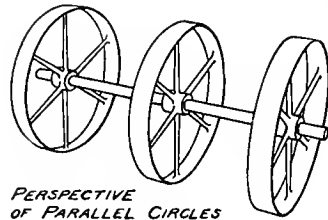

Fig. 39

## MODEL DRAWING

**222.** A course in model drawing from the object is of value for several reasons. It gives familiarity with the peculiarities of artificial type forms that are found singly or combined in all engineering constructions. It trains the faculty of exact observation. A drawing of a squash may be satisfactory, yet not much like the original. A drawing of a prism, a pyramid, a cylinder, a ring, a cone must be very nearly correct or the error is apparent to all. Third, the outlines of such objects are not lost in complex light and shade nor in color effects.

**223.** When making a perspective sketch of an object, hold the drawing board in an upright position so its plane is perpendicular to your sight as you look down on it. It should be held low enough, so you can look over its upper edge at the object and then back again at the drawing with only a slight movement of the head.

Before beginning to draw, read again Sections 211 to 220 inclusive and the suggestions in Chapter VI and endeavor to apply them. Refer to them continually if you wish to be successful.

Make your drawings of generous proportions. It may be easier to draw a short line than a long one, but it is more difficult to get proportions correct in a small drawing than in a large one.

**224.** Suppose it is desired to make a sketch of the cube as shown in **Fig. 40**.

Sit back in your chair in an erect position with the drawing board resting in an upright slanting position on the knees. **When looking at or testing the lines of the object, be careful to occupy always the same position.**

Proceed in the following order. Draw verticals of indefinite length, to represent the vertical edges of the right face. Estimating with the eye, decide on the relative horizontal widths of the vertical faces, then draw the left vertical of the left face. Take a point B on the middle vertical and judging the inclination by the eye, draw the top edge of the left face. In the same way, draw the top edge of the right face. The inclination of these lines may be more accurately judged, if the eyes are closed until the lines are just visible. The draftsman may hastily conclude that the back edges of the top face appear parallel to the corresponding front edges, but careful scrutiny with partly closed eyes will prove the

contrary to be true. Having decided on their inclination, draw them, completing the top face. Next, estimate the length of the middle vertical, comparing with the horizontal width of the right face. Mark its length and draw the bottom edges of the side faces in the same way as the top edges.

The drawing should look pretty "scratchy" by this time if the instructions in Section 178 have been followed.

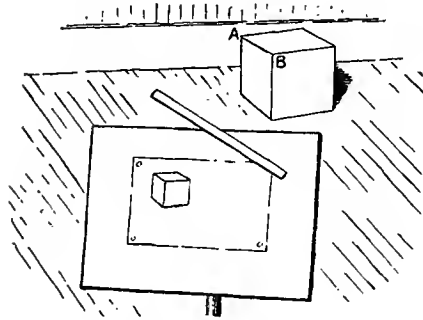

Fig. 40

225. Now test the drawing by comparing lengths of lines and other suitable dimensions, and by measuring inclinations of lines.

Remember that it is the apparent lengths and not the true lengths of lines of the object which are to be compared.

To compare lengths of the front edges of the top face, sit in the same position as when drawing them. Grasp the pencil at one end by the fingers of the right hand, leaving the thumb free to be moved back and forth on the projecting part of the pencil. Without moving the body, stretch out the arm straight to full length; then swinging the arm from the shoulder, bring the pencil so it appears near the right front edge of the top face. Now turn the hand, or the pencil in the hand until the pencil is perpendicular to the line of sight. Swing the arm

slightly and rotate the arm in the sleeve until the pencil appears to coincide with the line, the end of the pencil being at one end B, of the line. Move the point of the thumb along the pencil until it coincides with the right end of the line. The length on the pencil from its point to the thumb is the apparent length of the line. Without removing the thumb, swing and rotate the arm so as to bring the pencil to lie along the line AB with its end on A. Be sure the pencil is perpendicular to the line of sight. Note now, how the point B appears to divide the length from the end of the pencil to the thumb. Is it one-half, three-eighths or what? Having decided, compare the lengths of the same lines in the drawing. **In making these measurements the pencil must always be held at arm's length and perpendicular to the line of sight, or the results of the test will be worthless.**

**226.** To test the inclination of any line as AB, sit in the same position as when drawing the line. Place the board so its upper edge is horizontal and incline it until its plane is perpendicular to the line of sight. Take the pencil or a straight edge and lay it flat against the face of the board allowing several inches to extend beyond the edge as shown in **Fig. 40**. Look straight at the line AB to be tested and without moving the head, move the straight edge about on the surface of the board till it appears to coincide with AB. Holding it in this position, look immediately at the corresponding line in the drawing and note if it is parallel to the straight edge. After some practice in this way, it will be found accurate enough and quicker to judge of the inclination of the line by half closing the eyes and comparing with a pencil held horizontal. Then quickly place the pencil horizontally on the drawing next the line being tested and note if the angle is the same.

Test the drawing until the correct lengths and inclinations are established, then remove superfluous lines. By using light sketch lines, this task will not be an arduous one.

**227.** When drawing cylindrical forms, draw the ellipse first after establishing the slant of the major axis and the ratio of lengths of axes. Then draw the straight side lines, being careful that their direction is such as to make the axis of the cylinder perpendicular to the major axis of the ellipse.

**228.** The peculiarities in appearance of the conventional geometric forms are best studied in the regulation white models made for this purpose. A fairly large model is best for showing the outlines distinctly and a white surface is desirable, as the eye of the beginner is thus not confused by strong shade or color effects. If such models are not available, nearly all the type forms may be constructed easily out of cardboard. Most of these models are duplicated in form by articles in domestic use, such as boxes, cartons, pans, pails, cans, funnels, curtain rings, various forms of crockery, glassware, etc.

The convergence of parallels and shortening of equal spaces may be observed in grills, lattice work, fences, and rows of windows, while the appearance of parallel circles is illustrated by tanks, barrels, cement pipe, umbrella jars and many other forms seen every day.

## EXERCISES IN MODEL DRAWING

**229.** The following models taken in order will give a progressive set of exercises sufficiently comprehensive. Place them on the table or floor below the eye level and draw them in various positions. While doing this verify and apply the principles of projection and perspective which have been previously stated in Sections 211 to 220 inclusive. A—**Cube**, B—**Square Prism** on end and on side, C—**Square Frame** lying flat and upright, D—**Triangular Prism** on end and on side, E—**Triangular Frame** lying flat and upright, F—**Hexagonal Prism** on end and on side, G—**Hexagonal Frame** lying flat and upright, H—**Square Pyramid** on base and on side, I—**Hexagonal Pyramid** on base and on side, J—**Cylinder** on end and on side, K—**Half Cylinder** on end and on flat side, L—**Flat Ring** lying flat and upright, M—**Cone** on base and on side, N—**Sphere**, O—**Hemisphere** lying on flat surface and on curved surface, P—**Torus Ring** lying flat and upright.

After practicing on these elementary forms, more difficult objects involving combinations of them may be tried. Complicated constructions should not be attempted at this stage, the endeavor being to fix the attention on elementary principles. Almost any simple object will be useful. Machine parts similar to those shown in **Figs. 33, 34, 47 and 48**, pipe fittings, old patterns and laboratory apparatus can generally be readily obtained.

## CHAPTER IX

### AXOMETRIC SKETCHING

**230.** At **Fig. 41**, A, is shown the projection on a vertical plane of a square parallel to it. Take an axis line X-X in the plane of the square and through its center. If the square be revolved on this axis until its plane is perpendicular to the plane of projection, its projection will be a straight line as shown at E.

Intermediate positions will give projections as at B, C and D.

In the original projection at A, draw the horizontal QR, the verticals MQ and OR.

The triangles MPQ and OPR are equal and the following proportion is true.



$\frac{MQ}{OR} = \frac{PR}{PQ}$ . When the square is revolved, these triangles change their form in the projection,

but it can be proved that the proportion is true for all positions between the extremes mentioned.

**231.** This fact gives at once a quick way for drawing the projection of a square which is oblique to the plane of projection. Referring to Fig. 41, C, let it be required to construct the projection of a square so placed that the ratio of horizontal distances between its three nearer corners is  $\frac{3}{1}$ . That is  $PR = 3PQ$ .

Draw QR any desired length and take point P so  $PR = 3PQ$ . Erect verticals at Q and R. Draw MP at any desired inclination not greater than MP in A. Make OR the same fractional part of MQ that PQ is of PR, in this case  $\frac{1}{3}$ . Draw OP and MN parallel to it. Draw NO parallel to MP.

**232.** If the true length of side of the square represented is desired, it can be found by noting from Fig. 41, A, that it is the hypotenuse in a right triangle whose legs are equal to PQ and PR.

**233.** In Fig. 42, the projection CDEF of a square has been drawn by the method of Section 231.  $AC = 2BC$  and  $BD = 2AE$ . To complete the cube of which this square is the top face drop verticals at C, D and E. Draw trial lines for the bottom edges GH and HJ, placing them so as to make the figure look like a cube. Now turn the drawing around until CDHJ becomes the top face and note if the drawing is still a good representation of the cube. It will probably be too tall or too short. Change the lines GH and HJ until the drawing looks like a cube in either position.

The exact lengths of the verticals can be found by geometric construction, but the method described is sufficiently accurate and much quicker.

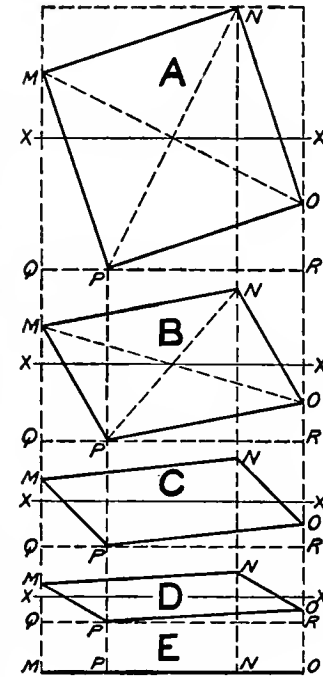

Fig. 41

- 234.** Find the center  $K$ , of the top face by the intersection of diagonals and draw  $PT$  through it perpendicular to  $CH$ . Mark the middle points of the sides of the top face and sketch in the ellipse which is the projection of the inscribed circle. Draw the ellipses for the other two faces, being careful to get the correct slant for the major axis. When completed, the three major axes should measure the same, if the work is accurate.

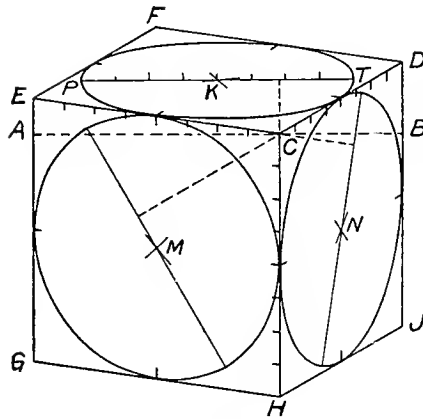

Fig. 42

Divide  $CE$ ,  $CD$ ,  $CH$  and  $PT$  into eight equal parts each.

- 235.** The three lines  $CE$ ,  $CD$  and  $CH$  represent lines actually perpendicular and of equal length. They may be considered as axis lines of length, breadth and thickness. If the cube which this projection represents were a 1" cube, then the projection of any other rectangular solid could be easily drawn by imagining the object placed with its edges parallel to those of the cube. Direct comparison could then be made between the lines in the projections of the two objects.

A circle in any face of the rectangular solid would be represented by an ellipse of the same shape as that in the parallel face of the cube. The size of the ellipse would be determined by a comparison of its major axis directly with that of the ellipse in the cube.

- 236.** In Fig. 43 is a sketch made in the manner just outlined. The object is the Hoist Arm Yoke whose dimensions are given in Fig. 9. The drawing is made of small size by assuming that the reference cube used, that of Fig. 42 is 4" on an edge.

At a point  $O$  draw three axis lines  $OX$ ,  $OY$  and  $OZ$  parallel respectively to lines  $CD$ ,  $CE$  and  $CH$  of the reference cube. For convenience in measurement, lay off from  $O$  on  $OX$  a length equal to  $\frac{1}{4}$  of  $CD$ , a length equal to  $\frac{1}{4}$  of  $CE$  on  $OY$  and on  $OZ$  a length equal to  $\frac{1}{4}$  of  $CH$ . Each of these lengths represents an inch measured in the direction of its axis. These lengths are divided into quarters.

Following the dimensions as given in Fig. 9, make  $OA$  7",  $OB$  2 $\frac{3}{4}$ " and  $OC$  2". Draw  $CD$  parallel to  $OA$ ,  $AE$  and  $CG$  parallel to  $OB$ ,  $AD$  and  $BC$  parallel to  $OC$ . Make  $AE$  equal to  $OB$  then draw  $EH$

and FB parallel to OA and  $\frac{5}{8}$ " long. Draw HR and FS parallel to OB and  $2\frac{1}{4}$ " long. Draw RS parallel to OA. Mark point J so that CJ equals  $3\frac{1}{4}$ ". Make JK  $\frac{5}{8}$ ", KN  $1\frac{1}{4}$ ", and KQ  $1\frac{3}{4}$ ". Draw in order QP, JL, PN, PM, NL and ML, parallels to the lines of the ear first drawn. Make OU 1" and draw a parallel to OB through U. Make CT  $2\frac{1}{8}$ " and draw a vertical through T. The intersection of these two lines is the center of the  $\frac{5}{8}$ " tapped hole. Draw the major axis of the ellipse perpendicular to OA and base its length on the line PT of the reference cube of Fig. 42. Draw the ellipse the same shape as that in the right face of the reference cube. The hole in the ear is located and the ellipse drawn in a similar manner. The shape of this ellipse will be like that in the top face of the reference cube and its major axis is perpendicular to OC.

The projection of any object, however complicated, may be drawn in this way, if its dimensions are known. As an endless variety of reference cubes can be constructed, it is always possible to select the most suitable position for representing the object.

237. A drawing made in this way is called an **Axometric Drawing**, because the directions and measurements of lines are referred to axes representing the three principal dimensions of an object: length, breadth and thickness.

238. If Fig. 43 is held at arm's length it looks correct, but from the usual distance of about 12" the further edges appear longer than the near ones and the lines supposed to be parallel appear to diverge away from the eye. Correct the drawing by shortening the lines until they look right and converge the parallels until they look parallel. In other words modify the drawing, so it will not violate the principles of perspective. In Fig. 44 is an axometric drawing of a center rest jaw. Note that the back

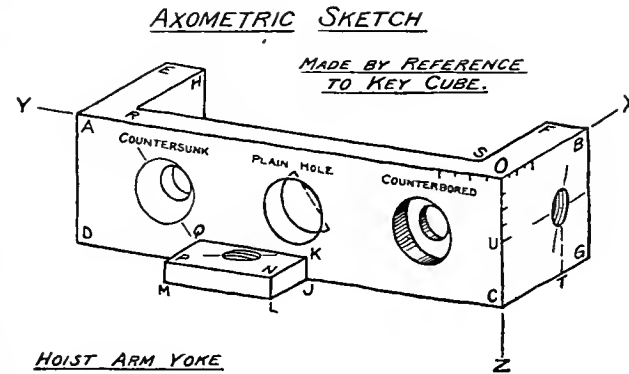

Fig. 43

corner appears tilted up and the back end appears larger than the front end. The second drawing shows the axometric drawing modified by introducing convergence of parallels. Although changes in the drawing are slight, the change in appearance is marked.

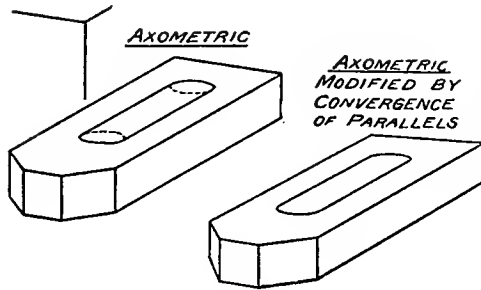

Fig. 44

239. In Fig. 45, are shown a number of drawings of type forms made in the way just described. At R, is a box cap composed of a semi circular shell with two ears. The complete elliptical end should be sketched in as indicated by the dotted lines, until the draftsman has become familiar with the appearance of the half cylinder form.

240. In the case of truncated pyramids or cone forms, work with the vertex as shown in D and T.

241. Where two irregular curves are placed symmetrically, draw the axis of symmetry first and plot the curves either side as in U.

242. The nut at K was constructed by first drawing the complete base, then all the faces, last the ellipses and the contour at the right of them. To get the curve at the top of a face, plot its middle and end points. This is an Isometric drawing.

243. At H is a drawing of the Spiral Gear Shaft of Fig. 9. Draw center line first and mark centers of ellipses dividing into proper lengths by the eye. Draw ellipses, observing the perspective effect of distance, then draw the straight sides with convergence.

244. **Threads** are drawn somewhat conventionally. A series of parallel ellipses with their major axes not quite perpendicular to the axis of the screw will be fairly suggestive of a screw thread. The shape of the ellipse should be the same as the end of the cylinder on which the thread is cut. Look out for spaces and the shape of the curve at the side line where it forms a slight notch. Threads are shown at D, E, G and H.

245. At F is a rapid sketch of a coil spring. If done accurately, the point of the loop on the right would be horizontally opposite the space between points on the left.

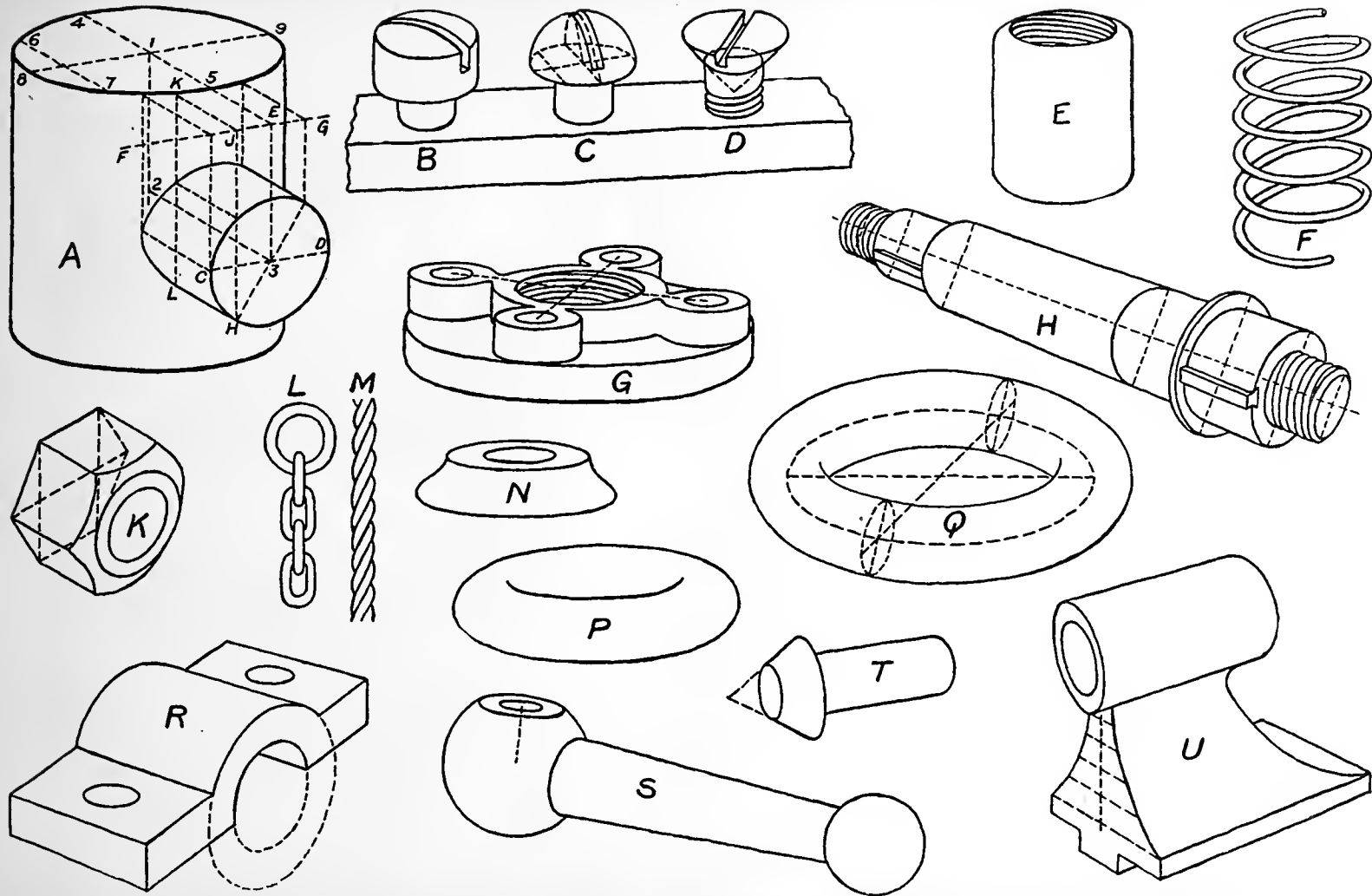

Fig. 45

**246.** At G is half of a Flange Union such as S of **Fig. 11**. Draw the central ellipse first, then the four small ellipses representing bosses for the bolts. The centers of the four are on lines at right angles in the object. Apply method of Section 199 to determine these lines.

After completing the upper ellipses, drop verticals and draw parallels to the upper curves. This is an axometric drawing without perspective modification. Note how the left side appears tilted, because of this. All of these ellipses have horizontal major axes.

**247.** In the washer at N, sketch bottom ellipse complete before drawing side curves.

**248.** At E is a straight coupling like A of **Fig. 11**. Note how the effect of a rounded edge on the end is produced.

**249.** The character of a surface is often brought out by the curvature of lines on it. This is particularly true of spherical surfaces. Note this in the **Binder Handle** at S, **Fig. 45**. Observe that the major axis of the ellipse representing the flat place on the ball is perpendicular to a radius of the sphere drawn from its center.

Straight lines for the slot on B would convert the curved top into a flat one.

At C, note that the outline of the hemisphere is made up of a semi-circle and a semi-ellipse. Also notice how the curved lines of the slot are determined.

**250.** At Q, **Fig. 45**, is shown a **torus ring**, a form occurring in valve handles, hand wheels, pipe returns and bends.

If we take equal paper circles, each with a small hole at its center, and fill a wire circular hoop with them, we shall have a torus ring. Each circle will adjust itself so its plane is perpendicular to the wire at the point where it is situated. A projection of the wire hoop would be an ellipse, as shown in the dotted line in Q. Each paper circle would project as an ellipse. The major axis of each ellipse would be perpendicular to the curve of the wire, i. e. to the curve of the large ellipse. Major axes of all the small ellipses would be equal. If all the small ellipses were drawn and a tangent contour to them made, we should get the outline of the ring. This outline is thus composed of curves parallel to the elliptical center line. One

extreme position will show the ring as two concentric circles. The other extreme shows it as two semi-circles connected by parallel lines.

**251.** If it is desired to draw a return bend like J of Fig. 11, draw the complete torus ring and cut it in halves as shown by dotted lines in Q, Fig. 45. To draw the small ellipse which represents the circular cut, draw the major axis perpendicular to the large ellipse curve at that point. A second diameter of the small ellipse, (not the minor axis) is found on the end of the oblique diameter of the large ellipse. From the relation of the lines the following proportion is true.

Referring to Fig. 46, G, V-F is to V-G as D-E is to the major axis of the horizontal ellipse.

If a quarter turn is desired, the ring may be divided into quarters in the same way and by use of the construction of Section 199.

**252.** At L and M are shown chain and rope as they appear when hanging vertical.

**253.** In sketches of sheet metal work, it is often desired to show the intersection of various surfaces. A pure guess will generally result in a bad representation, unless the draftsman is familiar with the different intersection curves.

If the draftsman understands the construction of intersection curves by means of parallel cutting planes, the following method will prove useful.

In A, Fig. 45, is given a vertical cylinder whose axis is along 1-2. It is intersected by a cylinder whose axis 2-3 is perpendicular to that of the large cylinder at its middle point 2. The diameter of the small cylinder is one-half that of the large and its axis 2-3 is equal to the diameter of the large cylinder.

Having drawn the projection of the large cylinder as desired, find the middle point, 2, of its axis. Draw the axis 2-3 of the small cylinder at any desired inclination. To find 3, draw 4-5 parallel to 2-3 and make 2-3 equal to 4-5. Draw the major axis of the ellipse perpendicular to 2-3 and make its length half that of the ellipse of the large cylinder. To find a second diameter of the ellipse (not its minor axis), draw 8-9 a diameter perpendicular to 4-5 by the method of Section 199. Draw C-D parallel to 8-9 and of length equal to 8-1.

In the actual object 8-9 is perpendicular to 4-5 and 1-2, therefore perpendicular to the plane 1-2-3 E of the axes of the cylinders. The line C-D being parallel to 8-9 is perpendicular to the same plane, therefore perpendicular to the line 2-3. Line C-D must then be in the plane of the end of the small cylinder.

Draw the ellipse through points C, D and the extremities of the major axis, making it symmetrical on the latter.

**254.** To find the intersection, draw first the line FEG which is the intersection of the planes of the ends of the cylinders. Cut both cylinders with a plane HJKL which is parallel to the plane of their axes. This plane will cut an element out of each cylinder, thus LH from the small and LK out of the large cylinder. These two lines intersect at point L which must therefore be a point common to both surfaces, or a point in their intersection. Other points may be found in the same way. Three or four are usually sufficient including those for the side lines of the small cylinder.

**255.** It may be objected, that the errors in making such a construction free-hand will give worthless results. Experience of many years use with beginners has proved the contrary. The method with all its errors will give results far superior to those of a guess and with a trifling expenditure of time.

**256.** The Axometric Drawing gives us a rapid and accurate method for making a free-hand perspective drawing of an artificial object without the object or any drawing thereof, provided its construction and dimensions are known.

The method briefly stated is this. First, construct a reference cube. Second, by comparison with it make an Axometric Drawing of the object. Third, change this Axometric Drawing into a Perspective Drawing by applying the common perspective principles.

After the draftsman has followed this method for a time, he finds he can dispense with the reference cube and that he can introduce the perspective as he draws his lines. In other words, he has learned to make a perspective sketch of an object not before him and can therefore reproduce in this way what exists only in his mind. Such ability is of the highest value to the designer.

**257.** In Fig. 46 are rapid sketches of gearing which give a test of the application of the method. The least possible construction was employed in each case and most of this is shown in dotted lines.



# SKETCHES FROM WORKING DRAWINGS

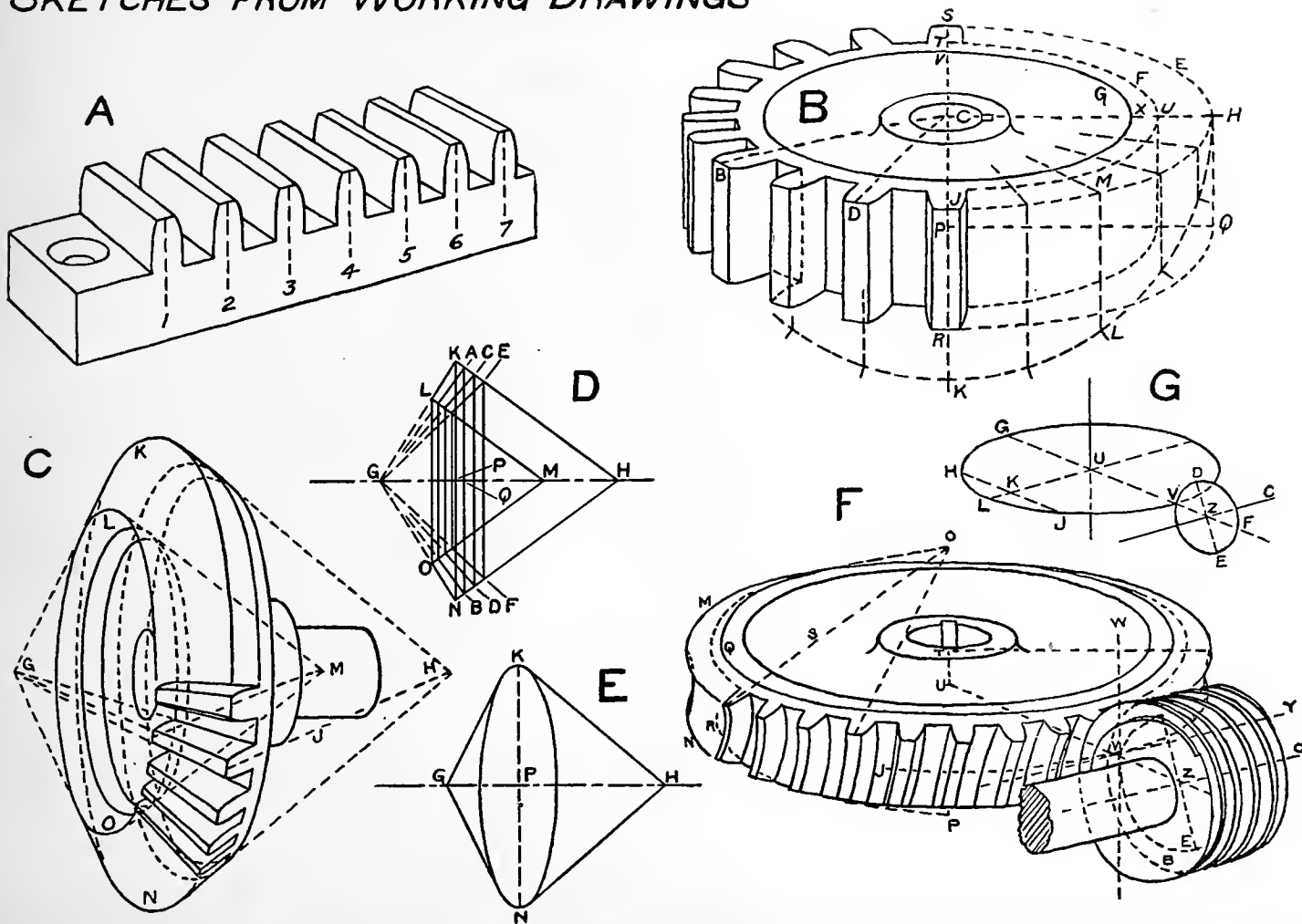

Fig. 46

Auxiliary sketches indicate the way in which the drawings were built. See suggestions in Sections 198, 199 and 251.

## EXERCISES IN AXOMETRIC SKETCHING

**258.** Make Axometric sketches of the parts given in the following list, selecting one or more from each group. Where complete dimensions are lacking, follow the general proportions, selecting some prominent line of the figure as the unit with which all other lengths are compared.

1. **Reference Cube.**—Make a reference cube with ellipses of about the same size as that of **Fig. 42**, but with a different relation between widths of the upright faces.

2. **Rectangular Prism Forms.**—Square Frame A, **Fig. 52** lying on its flat side and upright.—Rectangular Frame A, **Fig. 47**.—Gib head Key, **Tab. 6** and **Fig. 10**.—Straight Flat Key, **Tab. 7**.—Cotter, **Fig. 10**.—Block with T Slot, **Tab. 10**.—From **Fig. 10** and **Tab. 14**, a short length of an I Beam, a Channel, an Angle, a Z Bar, and a T Bar.—Rack, **Fig. 18**.—End of Plate Girder, **Fig. 20**.—Joints on Roof Truss, **Fig. 21**.—Column Base, **Fig. 22**.—From **Fig. 48**, Shoe J, Vise Strap O, Chuck Jaw P, Beam Stirrup V.

3. **Triangular Prism Forms.**—Triangular Prism, B, **Fig. 47**, on side, on end and with part above x—x removed.—Triangular Frame, **Fig. 26**, lying flat and upright.—Gauge Stop, **Fig. 9**.—Rod Rest B, **Fig. 48**.—Conveyor Bucket D, **Fig. 48**.

4. **Hexagonal Prism Forms.**—Hexagonal Prism C, **Fig. 47**, on side, on end and with part above x—x removed.—Hexagonal Frame, **Fig. 27**, lying flat and upright.—Hexagonal Nuts, **Tab. 1**.

5. **Pyramidal Forms.**—Square Pyramid D and Hex. Pyramid E, **Fig. 47**, resting on base, with and without part above x—x removed.

6. **Cylindrical Forms.**—Cylinder F, **Fig. 47**, lying on side and on end.—Flat and Oval Fillister head Cap Screws, **Tab. 3**.—Cylinder Cap, **Fig. 9**.—Knurled head Screw, **Fig. 10**.—Cotter Pin, **Fig. 22**.—Stud, **Tab. 4**.—Core from Core Box C, **Fig. 33**.

7. **Hollow Cylinder and Ring Forms.**—Ring D, **Fig. 52**, lying flat and upright.—Plain Shaft Collar, **Tab. 18**.—Punched Washer, **Tab. 9**.—Machine Knob, **Tab. 7**.—Spur Gear Blank, **Fig. 18**.—Worm Gear

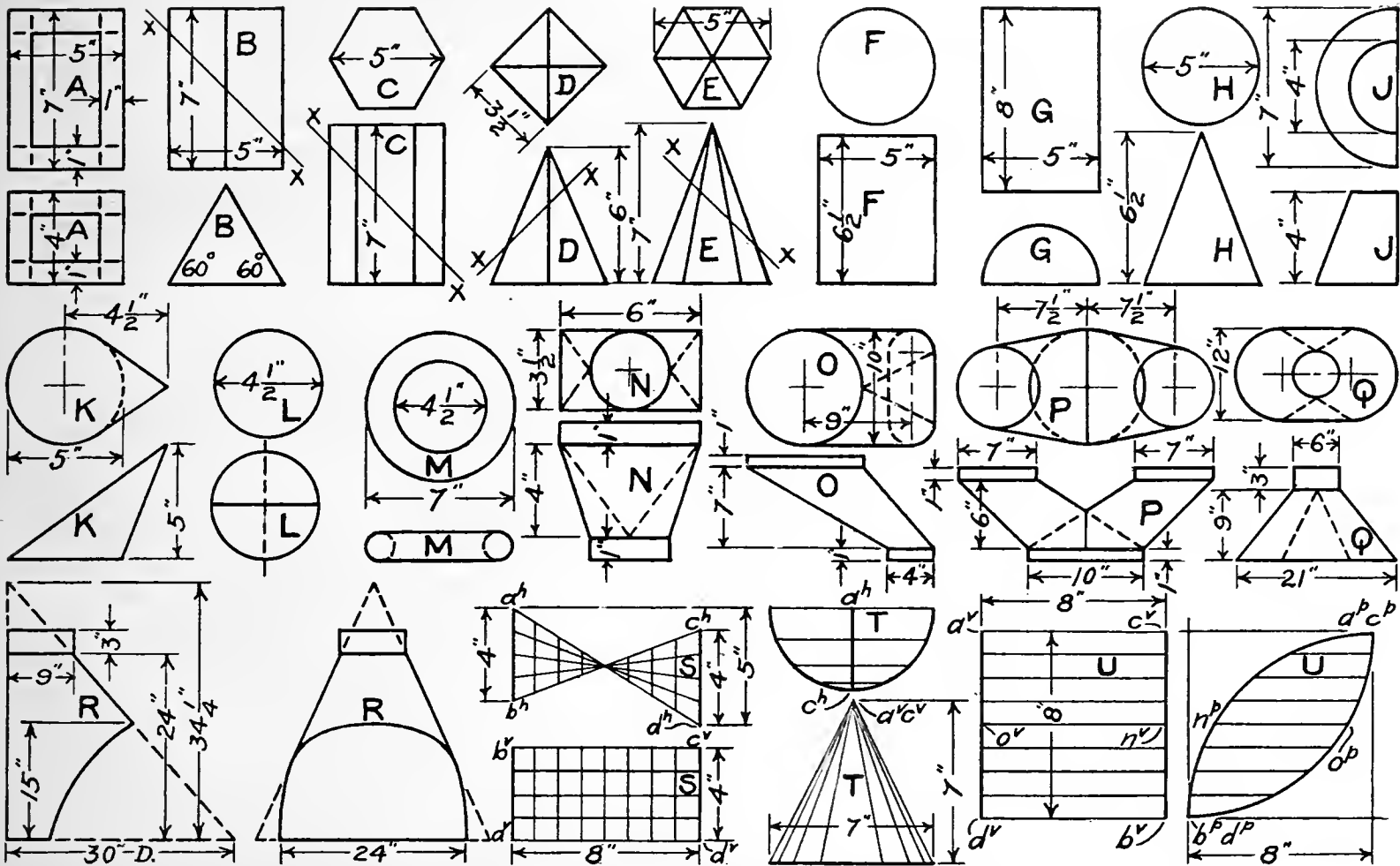

Fig. 47

Blank, Fig. 18.—From Fig. 11, Straight Coupling A, Cap C, Short Nipple L, Flange Union S.—Cam E, Fig. 48.—Speed Cone Q, Fig. 48.

8. **Combinations of Preceding Forms.**—Square and Hexagon head Cap Screws, Tab. 2.—Set Screw, Tab. 2.—Collar Screw, Tab. 4.—Anchor Bolts, Fig. 10.—Lag Screw, Fig. 10.—From Fig. 11, Plug D, Reducing Bushing N, Screw Union R.—I Beam and Connection M, Fig. 52.—Eye Bars, Fig. 22.—Rocker Arm, Fig. 32.—From Fig. 48, Journal Lug A, Renold Chain Link C, Cast Eye R, Screw S, Wrench U, Clapper Box W, Open Bracket Y.—Solid Box, Fig. 51.—Pawl Friction Shoe, Fig. 9.—Wing Nut, Tab. 7.—Flange Coupling, Tab. 16.—Solid Journal Box, Tab. 17.—Rigid Pillow Block, Tab. 18.—Angle Pillow Block, Tab. 19.

9. **Fractional Cylinder Forms.**—Half Cylinder G, Fig. 47, lying on flat side and on end.—Whitney Key, Tab. 1.—Half Ring E, Fig. 52.—Box Cap, Fig. 31.—Beam Separator, Fig. 22.—From Fig. 48, Tool Post Wedge G, Half Box M.—Half Compression Coupling, Tab. 17.

10. **Intersecting Cylinder Forms.**—From Fig. 11, Pipe Tee E, Y Branch F, Cross P, Flanged Tee V.—Safety Collar, Tab. 19.

11. **Divided Circle Forms.**—(Section See 198.) Ratchet Wheel L, Fig. 52.—Jaw Clutch Coupling, Tab. 15.—Face Plate B, Fig. 8.—From Fig. 48, Face Plate F, Scale Weight K, Valve Handle T.—Spur Gear, Fig. 18.—Machine Hand Wheel, Tab. 8.—Pulley, Tab. 20.—Spur Gear, Tab. 20.

12. **Cone Forms, Simple and Combined with others.**—From Fig. 47, Right Circular Cone H, resting on base and on side, Truncated Half Cone J, resting on base and showing flat side, Oblique Circular Cone K, resting on base. **Sheet Metal Forms** based on the Oblique Cone.—Transition Connection N, Boot O, Three way Pipe P, Hood Q, Hood R.

Lathe Center B, Fig. 8.—Countersunk head Rivet, Fig. 10.—Countersunk head Cap Screw, Tab. 3.—Box B, Fig. 8.—Pan head Rivet, Fig. 10.—Blanks for Bevel Gears, Fig. 18.—Reducing Coupling B, Fig. 11.—Washer H, Fig. 48.—Boiler Patch Bolt L, Fig. 48.—Taper Shank, Tab. 13.

13. **Sphere Forms.**—Sphere with Axis and Equator L, Fig. 47.—Ball Lever Handle, Tab. 9.—Button head Rivet, Fig. 10.—Button head Cap Screw, Tab. 3.—Ball Crank Handle, Tab. 9.—Cap Nut N, Fig. 48.—Railing Fitting, Tab. 12.

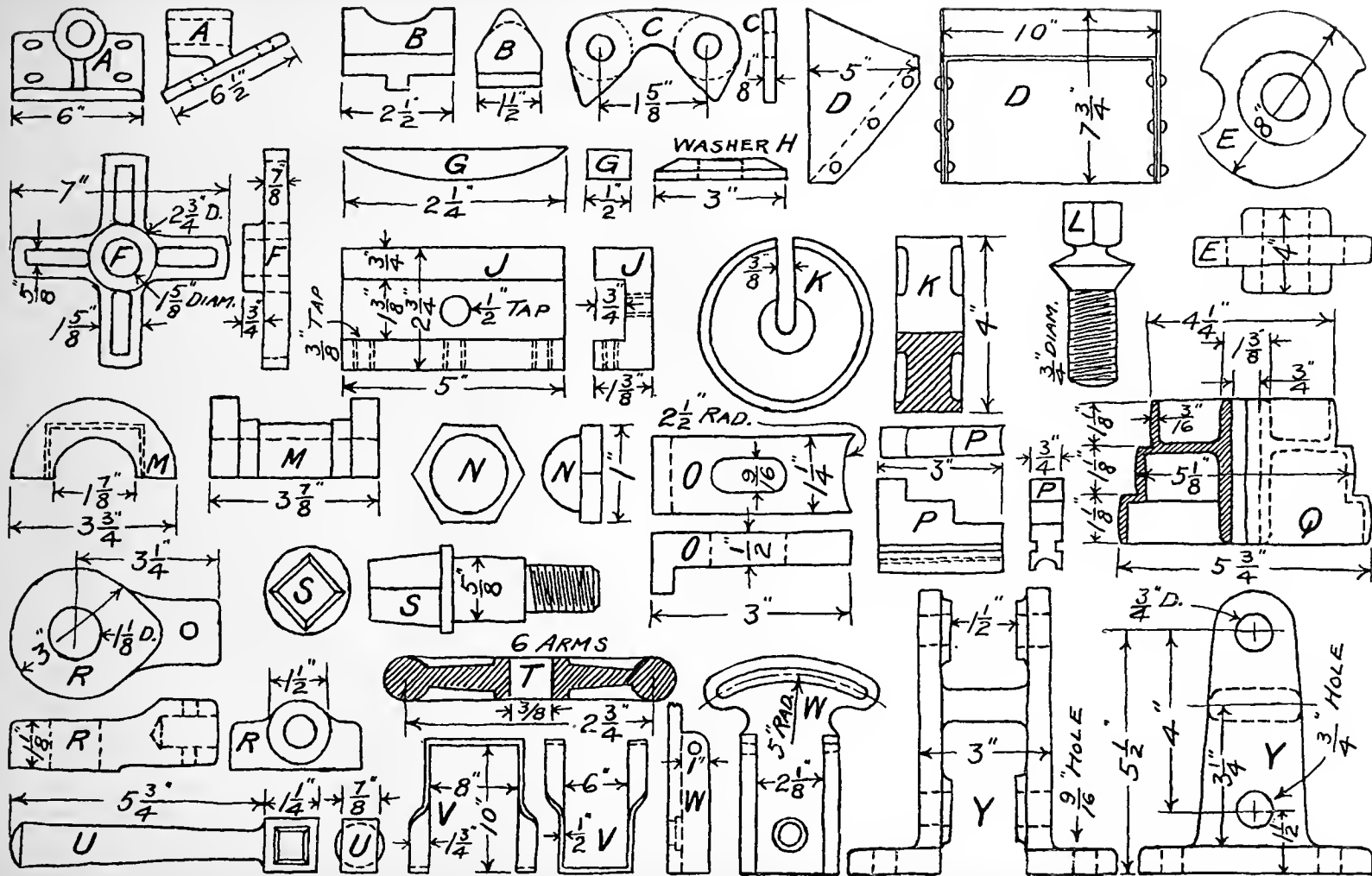

Fig. 48

14. **Torus Ring Forms.**—Torus Ring M, Fig. 47, lying flat.—Valve Handle T, Fig. 48.—Machine Hand Wheel, Tab. 8.—Eye Bolt, Tab. 10.—From Fig. 11 (See Section 251) Return Bend J. Elbows, G. T, and X.
15. **Miscellaneous Forms.**—Cast Washer, Tab. 10.—Machine Handle, Tab. 9.—Latch Handle A, Fig. 8.
16. **Warped Surfaces.**—(Represented by drawing the straight lines of the surface.) Fig. 47, Warped Plane S, Warped Cone T, Warped Cylinder U.

## CHAPTER X

### ISOMETRIC DRAWINGS AND CABINET PROJECTIONS

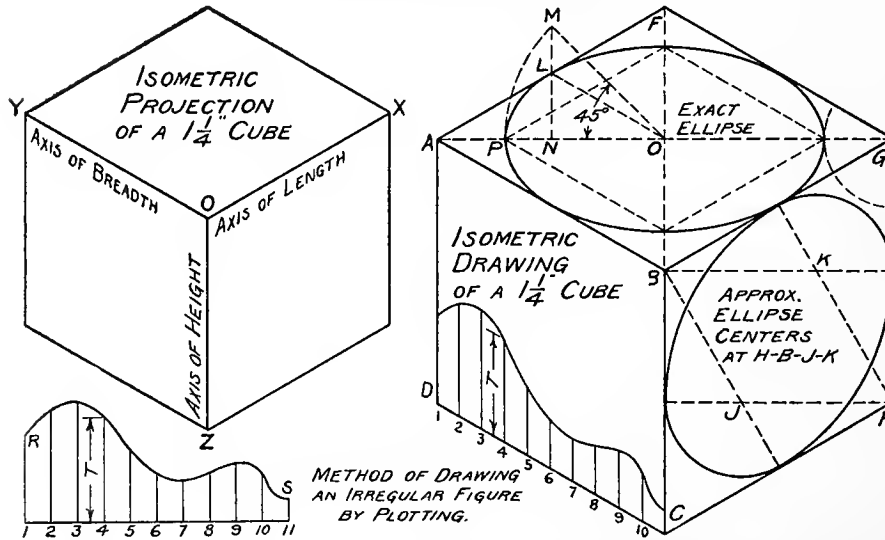

Fig. 49

259. In Fig. 6, C, is shown the projection of a cube obtained by placing the cube so its dimensions of length, breadth and thickness make equal angles with the plane of projection. It does not otherwise differ from any ordinary projection. It is called an **Isometric Projection**. In Fig. 49 is shown such a projection of a  $1\frac{1}{4}$ " Cube. The edges in the projection will be less than  $1\frac{1}{4}$ " because of foreshortening. In the same figure, is a drawing similar to the projection, but larger. In this drawing, the lines representing the edges of the cube are just  $1\frac{1}{4}$ " long. This is called an **Isometric Drawing**. It is a special form of an







**267. Exercises.** From Fig. 47, Rectangular Frame A, Triangular Prism B, Hexagonal Prism C, Square Pyramid D, Hexagonal Pyramid E.—From Fig. 48, Rod Rest B, Conveyor Bucket D, Face Plate, F, Shoe J, Half Box M, Strap O, Wrench U, Stirrup V.

Make a drawing similar to Fig. 7 in which the object is a straight line not parallel to any face of the cube and having each end in a face.

## CHAPTER XI

### COMPARISON OF METHODS OF REPRESENTATION

**268.** The different methods of representation are not equally adapted to all purposes. The following comparison may not be agreed on by all draftsmen, but it is a fair statement. Isometric Projection is not considered, as it is not used. An Isometric Drawing has all its advantages without its difficulty of scaling.

### GEOMETRIC PERSPECTIVE

**269.** Pictorially, a drawing of this kind may be very satisfactory if the visual angle is small. It has several unavoidable and objectionable distortions such as the tilting of the horizontal ellipse. It is not well adapted for rapid execution on account of necessary construction. Such a drawing should be made with instruments to secure a proper degree of accuracy. It is not adapted to dimensioning because of convergence of parallels. It cannot be used as a working drawing, because it cannot be scaled and because of the confusion caused by hidden lines and full lines of the object. Though its underlying principles are comparatively simple they are not quickly grasped.

A drawing of this kind is especially useful for architectural drawings of buildings and manufacturing plants, and is sometimes the only way in which they can be represented. A photograph is a true perspective and less expensive, but in many confined situations, a photograph cannot be made. Fig. 2, A, is a Geometric Perspective Drawing.

## ARTISTS' PERSPECTIVE BASED ON AXOMETRIC

270. Pictorially, this is the most satisfactory of all drawings. It has no distortions and is therefore pleasing to the eye. It can be made free-hand with great rapidity, but not so rapidly with instruments. It is not adapted for dimensions, nor for working drawings, because of the convergence of parallels and because everything is crowded into one view. The principles on which it is based are simple and its methods are quickly acquired.

It is undoubtedly the best kind of a sketch for rapid and forcible free-hand illustration of the details of engineering construction.

## COMMON PROJECTIONS

271. Pictorially, a drawing of this kind is apt to be deficient, because some study may be required in reading it. This will depend on the simplicity of the object. Hidden lines can be represented with less confusion than in any other kind of drawing. It has no distortions. It is adapted to rapid execution free-hand and yet better adapted to instrumental drawing because of its verticals, horizontals and circles which predominate. On account of the possible multiplication of views its carrying capacity for dimensions and specifications exceeds that of any other drawing. Neither can the meaning of a dimension be misunderstood. Its principles are simple and quickly learned. It is above all the best drawing for mechanics and engineers to work by.

## ISOMETRIC DRAWINGS

272. Pictorially, this kind of a drawing lacks the distortions of a Geometric Perspective and possesses those due to lack of convergence. The available positions of the object are very limited. Overlapping of parts and coincidence of lines often makes it difficult to read. It is adapted to rapid execution especially with instruments and of all the drawings showing three dimensions, it is the best adapted for dimensioning. It is often used as a working drawing for simple parts. It is simple in theory, usually easily understood and applied. A drawing of this kind is used considerably for showing interiors of buildings and details of construction, as it can be quickly drawn with instruments. **Fig. 6, A**, is an Isometric drawing. It is better adapted for this illustration than a Geometric Perspective, because convergence

of the projection lines would give a wrong impression to a student. Isometric drawings are much used to record insurance surveys of manufacturing plants.

### OBLIQUE PROJECTIONS

**273.** There is no demand for an oblique projection in which the object is placed with no face parallel to the plane of projection. Such a representation resembles a linear perspective drawing chiefly in having all the distortions of the latter. It also has the distortions of Isometric and Axometric, namely, lack of convergence of parallels. When made as explained in Section 266, and applied only to rectangular objects, the results are less objectionable.

In spite of its deficiencies, it is often useful. **Fig. 7** is an Oblique Projection and it is better adapted to the conditions than a Perspective or Axometric would have been. A Perspective would not have permitted parallel projection lines, but would have permitted bringing all faces of the cube to a position showing their true shape. An Axometric would have satisfied the first condition, but not the second. A Cabinet Projection would have met both conditions satisfactorily, but would have caused bad overlapping of views.

### CABINET PROJECTIONS

**274.** The remarks relative to distortions in oblique projections apply equally to Cabinet Projections. An additional defect is that the object can be shown usually in only three limited positions. Its bad features as a working drawing are shown in **Fig. 51**. It should be used for rectangular forms only, as this avoids the worst distortions and permits rapid mechanical construction.

## CHAPTER XII

### SHADE LINES AND LINE SHADING

**275.** If an object is illuminated by direct light it will cast a shadow. The outline of this shadow is composed of the shadows of certain edges or lines of the object. **A line which is said to cast shadow is one which separates a lighted surface from one that is in shade.** In a projection drawing, these lines are

# USE OF SHADE LINES

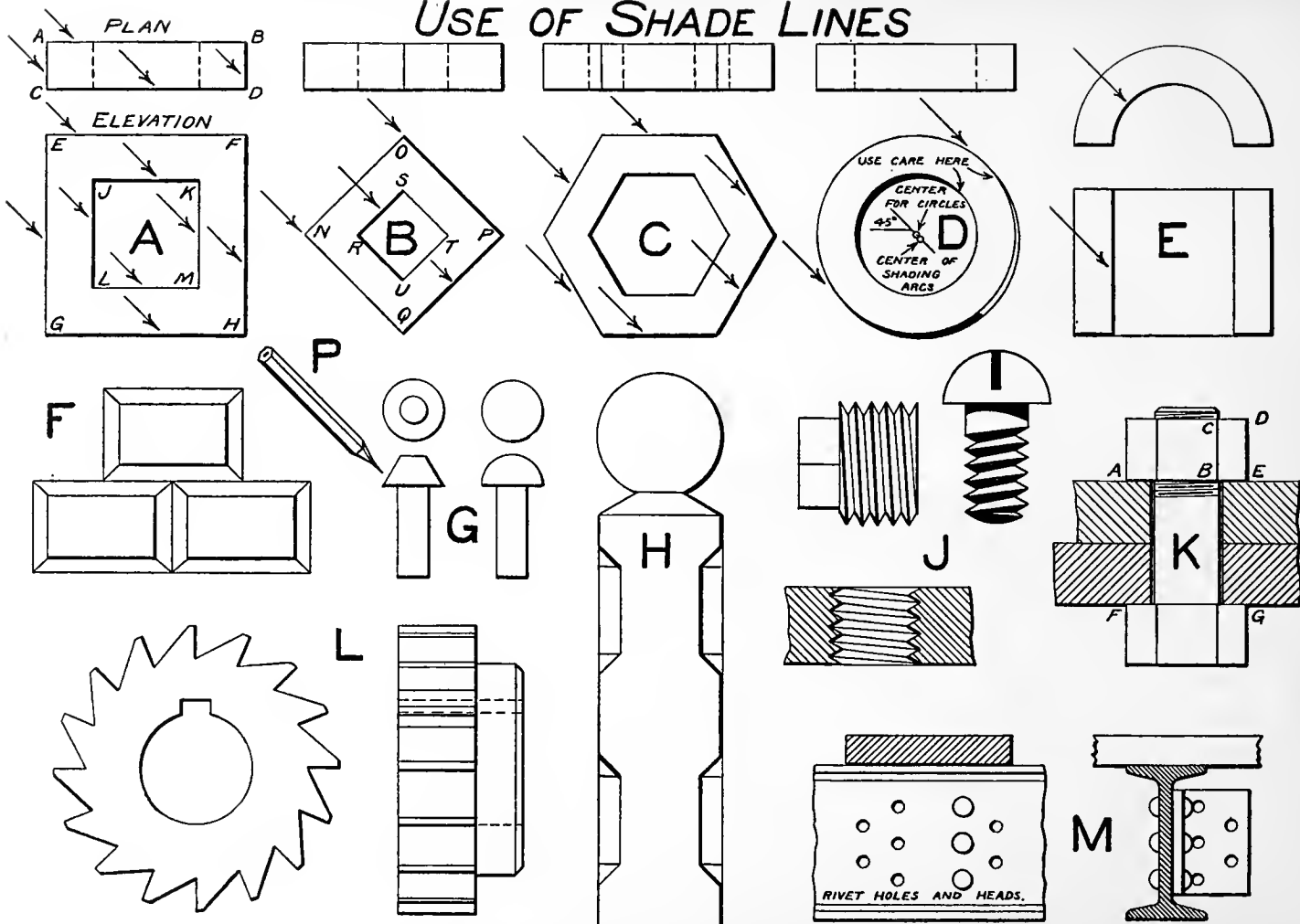

Fig. 52

made twice as heavy as the other lines and are called **shade lines**. The object of using shade lines on a drawing is for the pictorial effect only. They impart an appearance of solidity. Shade lines are now seldom used on working drawings, but are often used in drawings made for purposes of illustration.

**276.** Light is assumed to be coming down in parallel rays over the left shoulder of the observer as he stands looking at the object which is supposed to be built out solid on its projection. The slant of the rays is such that their projections on the planes of projection have an inclination of  $45^\circ$ . To select the lines that cast or form the shadow, the pencil may be set up as a light ray, as shown in **Fig. 52, P**, and applied to the projection.

In the square frame **Fig. 52, A**, the front surface is in the light, while the surfaces at FH, GH, JK and JL perpendicular to the plane of the paper are in shade.

The lines mentioned, therefore separate light from dark surfaces and will be made heavy. Note that the shade lines on the plan of the frame have been selected as if it were an elevation. **In selecting shade lines, the view is always treated as if it were a front view.** The various drawings in **Fig. 52** fully illustrate present practice in use of shade lines. Shade lines for cylinders, cones and spheres are selected in a conventional way as indicated. Theoretically, the shading of a line should be on the outside of a projection, but such a rule cannot often be followed. It is more frequently put on the inside of the line of the projection. At K and M are drawings of connected parts which show how the shading is applied to avoid notching of the lines.

**277.** If it is desired to carry the pictorial effect still further, this can be done best by representing the light and shade effect on the surfaces. There are various ways of doing this, ranging from the complex productions of the artist to the conventional representations of the mechanical draftsman. The latter method only will be presented here, and very briefly, too, as it aims to be suggestive merely.

The positions of object and observer and the direction of the light are assumed the same as for shade lines. The general appearance of surfaces having various positions relative to the light and to the plane of projection is fully illustrated in the

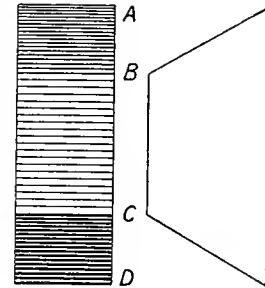

Fig. 53

drawing of the **hexagonal block shown in Fig. 53**. The surface A-B is in the light and inclined to the plane of projection. The part nearest the observer appears the brightest and the change in shade from darkest to lightest is a uniform one.

The effect is obtained by using a line of uniform width and increasing the space uniformly from back to front on the surface. If this increase of space width is not uniform, the surface will appear curved.

The surface B-C is in the light and parallel to the plane of projection. The light appears uniform on the surface and the effect is obtained by using a line of uniform width and a space of uniform width. The brightness depends on the width of line and of space, but it is better to use a fine line than a wide space to secure a light effect.

The surface C-D is in the shade and inclined to the plane of projection. The part nearest the observer appears the darkest and the change from dark to light is uniform. The effect is obtained by using a heavy line of uniform width and by increasing the width of space uniformly, though slightly, between the front and back edges.

Some draftsmen prefer to have surface B-C the same shade as the darkest part of A-B. In this case, A-B should be much lighter at B.

**278.** In shading the preceding flat surfaces, a line of uniform width was used on each and the same method can be used in shading curved surfaces, particularly small ones. Better results can be obtained usually though by changing the width of both line and space.

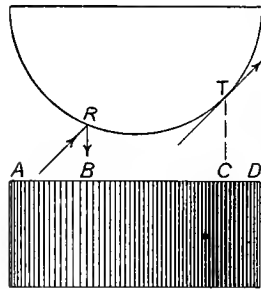

Fig. 54

Consider first the **convex vertical cylinder shown in Fig. 54**. Referring to its plan showing the projections of light rays, it is seen that light striking an element R,  $22\frac{1}{2}^\circ$  to the left of the center, is reflected to the observer in a direction perpendicular to the plane of projection. R is therefore the brightest strip on the surface. The light is seen to be tangent to the surface at the element T,  $45^\circ$  to the right of the center. Element T will therefore be the darkest strip on the surface. These two lines at R and T divide the surface into three parts which will be considered separately.

The portion A-B as in the case of the hexagonal block, will appear darkest at

A, but the change from dark to light is abrupt near A and more gradual near B. To get the effect, start at A with a line of medium width and as B is approached let the line narrow very gradually, but widen the space more rapidly.

The surface from B to C corresponds approximately to the same surface on the hexagonal block except that there is a gradual change at B to the brightest and at C to the darkest parts of the entire surface. To get the effect, increase the width of line and decrease the width of space very gradually in working from B to C.

The part C-D is in the shade and inclined to the plane of projection, but also curved. It will be very slightly lighter at D than at C. To get the effect, narrow the line, at first gradually, then abruptly, in working from C to D and keep the space a narrow, uniform width the same as at C.

**279.** A hollow cylinder is shown in Fig. 55 and the method of locating the dark and light lines. To get the effect, shade the portion from A to B just like the part from C to B on the convex cylinder. Shade the portion from B to C just like the part from B to A on the convex cylinder.

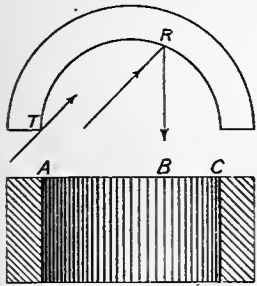

Fig. 55

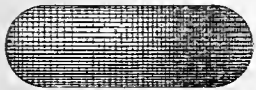

Fig. 57

**280.** A shaded cone is shown in Fig. 56. The light effect is obtained in the same way as for the convex cylinder. As each line must taper from base to vertex, use a needle to rest the straight edge against at the vertex and set the pen to make a fine line. Each heavy line is composed of a series of fine ones. The beginner will get them too heavy unless he is careful.

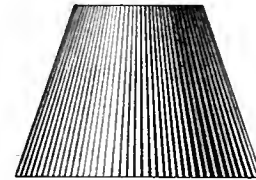

Fig. 56

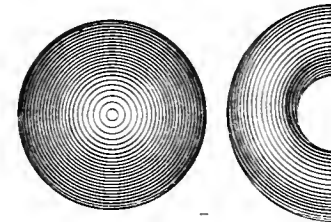

Fig. 58

**281.** The torus in Fig. 57 is shaded like a convex cylinder, vertically and then horizontally. This gives the effect of double curvature.

282. In Fig. 58 is shown a simple method of shading a **spherical surface**. It does not give a correct effect, but the exact effect is obtained only by methods of lining which require much skill and time.

283. A **half torus** or return bend is shown in Fig. 58, the effect being produced by setting the center of shading lines a little above the center of outlines.

## CHAPTER XIII

### FREE-HAND LETTERING

284. Although many styles of alphabets have been devised, only a few of them are adapted to rapid off-hand work or otherwise suitable for drawings used in construction. The novice is often confused in his selection by the great wealth of available material, and it is partly for the purpose of avoiding this that a very limited number of styles has been presented here. If one masters thoroughly the single stroke Gothic, he will have little difficulty with any other style.

Any free-hand lettering looks well, if it conforms to certain fundamental principles which insure uniformity in general appearance. For this reason the plainest letters, if well made, are often quite as effective as more ornate ones. While the general tendency is toward the use of the simpler forms, the decorative styles are also in frequent demand by the draftsman. These could not be satisfactorily included in such a brief treatment of the subject, but the treatises by Brown, Day and Strange provide all that could be desired along this line. A comparison of the contents of these books with the collections of alphabets formerly published for the use of draftsmen will afford considerable instruction in lettering as a fine art. To inlay the surface of a letter with mosaics and geometric designs or to drape it with biological rarities, does not make it beautiful. As a thing for use, its form should be recognizable, but beside this it may have so graceful a shape that there is pleasure in looking at it.

Good lettering on a poor drawing will not redeem the drawing, but a good drawing may have its appearance ruined by poor lettering. Poor lettering affects our estimate of a draftsman's ability in about the same way that illegible handwriting impresses us regarding the writer. Ability to letter well depends on the same qualities as free-hand drawing. It is needless therefore for a student to say he cannot letter



well, that he has no talent, is no artist. For what he calls talent is merely natural ability to observe correctly, combined with muscular control. Inasmuch as both these faculties may be acquired without excessive exertion, he can learn free-hand lettering by a little expenditure of reason and will.

**285. Mechanical lettering** differs from free-hand lettering in that the letters in their final forms are made with instruments although they may have been sketched first free-hand. The curved parts are lined first by means of the compass or curved ruler, straight parts with the tee square and triangles. A **combination of mechanical straight parts and free-hand curved parts is usually unsatisfactory** unless the draftsman is an expert. Care regarding tangencies of straight lines and curves is as essential as in geometric drawing, so the process is apt to be a tedious one. This excessive amount of time devoted to a minor matter constitutes the chief objection to the use of mechanical lettering on commercial drawings. From an artistic standpoint, a mechanical letter is often objectionable on account of its extreme precision and exact duplication, just as a piece of machine carving is less pleasing than that done by hand. With free-hand letters, this lack of flexibility does not exist because slight variations are unavoidable and no two As or Bs or Cs will be exactly alike.

**286.** While mechanical or free-hand letters may be well formed and satisfactory as letters yet they may not harmonize with their surroundings. Imagine the appearance of Old English type on a working drawing, or, if you will, the plain modern Gothic entwined with the traceries of a Moorish archway. The primary object of words is to say something. If the statement be in the form of a notice, the simpler the expression and the plainer the letters the better. If, however, we have a scriptural quotation used to fill bare space on a church wall, then something ornamental is desirable. Thus the question of lettering quickly merges into one of decorative design and the simpler forms of letters will be found modified into unusual shapes more or less artistic as will be seen by reference to memorial tablets, book covers and magazine advertisements.

**287.** Students (generally poor letterers) will often say, "Why should a draftsman learn to letter well; don't most drafting offices employ boys to do such work?" Their idea is, of course, that in the development of the division of labor in the drafting office, the first man makes a sketch of the design of a

machine, a second man elaborates details in pencil, a third makes a tracing of these in ink, a fourth puts on dimensions and a fifth the lettering. This may be all right in theory and it is in part the practice in some large establishments. In the great majority of cases, however, it will be found that the draftsman who begins the drawing does all the work on it. The only printing he may sometimes avoid is that for the title. In this matter practice varies, but the end in view is to secure uniformity and to economize time. It is for this reason that a boy who has a natural knack at lettering is often employed at low wages to put in all general and sometimes the sub-titles. The general title is often printed on a press with blank spaces to be filled in; or it is printed with rubber type and lined over to make the letters opaque for blue printing; or the title is traced from a copy placed underneath. The dimension figures and printed specifications are put on by the draftsman who knows the drawing. And these **dimension figures especially must be so definite in form and prominent in size that they are not easily obliterated even in the blue-print.** Too much care cannot be exercised in this particular, for a slight irregularity in the drawing may cost hundreds of dollars to rectify when it has been duplicated in hard metal. A beam too short or a bearing out of place is an error not easily corrected and the responsible draftsman will pass through an uncomfortable season.

## FUNDAMENTAL PRINCIPLES

288. **Height and Width of Letters.** The underlying characteristic of good lettering is **uniformity in general appearance.** This applies to the height and width or to the **apparent area** covered by the individual letter. Referring to **Fig. 59**, lines 1 and 4, we see that all the capital letters are of the same height and nearly all have the same width which we may style the **normal width.** The **exceptions** are the I, the J which is roughly  $\frac{3}{4}$ , the M which is  $\frac{5}{4}$  and the W which is  $\frac{6}{4}$  of the normal width. **Figures are about  $\frac{7}{8}$  of normal width.** Looking at the small or **lower case letters** of this alphabet, we see in line 7 that the heights are variable. There is, first of all, a body in nearly all the letters, of a height equal to  $\frac{3}{5}$  that of the capitals. Six of the letters, b d f h k l, rise above the body to the full height of capitals, while a seventh, t, falls a little short of this height. Five of the letters, g j p q y, have parts extending below the body as far as the stems of the other letters extend above. The remaining letters a c e i m n o r s u v w x z



Fig. 59

have only the body, if we except the *i* which has a dot. The **normal width of the small letters** is about  $\frac{2}{3}$  of that of capitals. The *f i j l r t* are narrower, while the *m* and *w* are greater than normal width. The **ratio of normal width to height** for capitals and the bodies of small letters should be about  $\frac{4}{5}$ .

**289.** While the uniform heights and widths of letters as shown in the plates are satisfactory for the ordinary small sizes, they will often need modification in the larger ones in order to secure **uniformity in apparent size**. For instance, if the letters *A B R S* are all of the same width, the *A* will appear narrower than the *B* and the *S* than the *R*. When such is the case, the letter which seems narrow should be widened enough to overcome its defect. In the same way the *C G O* and *Q* may appear a little too short especially when placed to the left of a letter like the *B* or *E*.

**290.** If lower case letters are being used, the common rules relating to use of capitals should be followed. Words requiring Emphasis may be Capitalized, either on the Initial or **THROUGHOUT**. If capitals only are used **THEY MAY BE ALL OF THE SAME HEIGHT** or **INITIALS MAY BE LARGER, ON THE PROMINENT WORDS**. A word of minor importance like the "OF" **Fig. 65**, Title 1, line 2, would not have an enlarged initial unless it stood first in the line like "THE" in the fourth line of the same title. **When large and small capitals are thus used**, the small ones should be about  $\frac{2}{3}$  the height of the large ones. As they have no parts extending below the base line, **capitals permit the use of a larger letter** for a given vertical space than is possible where lower case letters are used. This is frequently of importance when condensing material in a table.

**291.** When letters and spaces are narrowed to less than normal width as compared with their height, they are said to be **COMPRESSED**; when they are made greater than normal width, they are said to be **EXTENDED**. Extended lettering will often look better than the normal as errors in parallelism are not so noticeable. The printer specifies a letter height by **points**. These range from  $5\frac{1}{2}$  to 72 points in metal sizes and a limited range of these is shown in **Fig. 64**.

**292. Slant of Letters.** Uniformity in the slant of letters is essential. Letters may be **vertical** as in "Worcester," may slant forward like common handwriting as in "Polytechnic" or backward as in "Institute." See **Fig. 60**. The vertical form is the most difficult as even an untrained eye notes slight

variations from the erect position. The forward slant is most used, especially for rapid work. The inclination is about  $22^\circ$  from the vertical or a rise of 5 on a base of 2. See Fig. 59, line 4. A beginner will sometimes do better with the back slant than with either of the others. It should always be tried, especially if the writer is left-handed.

It is customary to draw the top and bottom limiting lines for lettering of any kind. The slant of letters is determined by reference to these lines whether they be straight or curved. For instance, the limit lines for "Map of" on Fig. 65, Title 2, are arcs of concentric circles. In map drawings it is often necessary to use irregular curved limit lines as in "Salisbury St.," Fig. 61. Note that the parts of the letter which lie on the limit lines in straight lettering are found coinciding with the limit lines in curved lettering. In the same way the slant of any particular letter will be determined by the direction of the curve at its position. Sometimes, however, in ornamental work, vertical letters are used, as in "BOYNTON," Fig. 61.

The image shows two examples of hand-drawn lettering. The word 'BOYNTON' is written in a simple, slightly slanted, sans-serif style. Below it, the words 'SALISBURY ST.' are written in a similar style, but they are curved to follow the arc of a dashed line representing a limit line.

Fig. 61

The image shows three lines of hand-drawn lettering. The first line is 'WORCESTER' in a simple, slightly slanted, sans-serif style. The second line is 'POLYTECHNIC' in a similar style. The third line is 'INSTITUTE' in a similar style.

Fig. 60

293. **Styles of Letters.** There should be uniformity in the style of letters employed for the same body of text and usually for the entire drawing. Variation in styles is permissible in titles or for purposes of classification. As to the latter, in case of maps for instance, state names might be in one style, cities and towns in another. The tendency, however, is toward uniformity even here, with variation in the size or slant only for different features.

294. A common error is the mixture of capitals and small letters indiscriminately thus, DropForgings; or the mixture of Roman and Gothic, thus LATHE.

295. **Spacing of Letters and Words.** We must have uniformity in the apparent spaces between letters and the actual spaces between words. For small letters not exceeding  $\frac{1}{4}$ " high, in which the upright

part is formed with a single penstroke, the **normal space width** may be  $\frac{1}{4}$  or  $\frac{1}{3}$  of the normal letter width. That a definite rule generally applicable cannot be formulated is shown by the word "SMELTER,"

SMELTER  
SMELTER

Fig. 62

**Fig. 62**, upper line, in which the spaces between letters are all equal. On account of the large area between the L and T, the word appears to be broken in two parts. If this space is reduced enough to give the **appearance of uniform spacing**, as in the second line, we find that the T actually overhangs the L. The same modification of spacing will be necessary with the various combinations of A C F J L O P Q T V W and Y which, it will be noted, are the letters that do not fill out their parallelograms. **Space letters so they appear to be evenly distributed throughout the word.** If we

drop a letter out of a word thus, LABO ATORY, the space between the O and A is the requisite amount for **readable spacing of words.** A good phrase to remember is, "**Crowd letters; spread words.**" It is natural to do the reverse. If, as sometimes happens, it is impossible to provide a proper amount of space, the division into words may be effected by using a large capital initial for each word. **Extra space must be allowed for punctuation marks** between letters or words. Title 3, **Fig. 65**, shows an exception to rules for spacing.

## DESCRIPTION OF ALPHABETS

296. Two alphabet styles, the Roman, **Fig. 63**, lines 1 and 2, and the single stroke inclined Gothic, **Fig. 59**, lines 1, 4 and 7, are used more than any others for drawings pertaining to engineering. The Roman is used especially in topographical work and the single stroke Gothic for shop drawings. **This sentence is printed in Gothic.** The word "Simple," **Fig. 63**, line 11, is in Outline Gothic. In the same way we have Outline Roman and Inclined Roman or Italic. The alphabet given in **Fig. 63**, lines 3 and 4, is a modification of the latter suitable for single stroke work. A single stroke Gothic capital may be changed to the Roman by the addition of **serifs**, the short horizontal terminals; **spurs**, the short terminals projecting from one side of the line and by increasing the line width on certain parts thus, **A** to **A**, **E** to **E**. The Roman is a more elaborate letter than the Gothic, requires more time to make and is therefore less suitable for

1 ABCDEFGHIJKLMNOPQRSTUVWXYZ &  
 2 abcdefghijklmnopqrstuvwxyz 123456789  
 3 *ABCDEFGHIJKLMN OPQRSTUVWXYZ &*  
 4 *abcdefghijklmnopqr stuvwxyz 123456789*  
 5 ABCDEFGHIJKLMNOPQRSTV VWXYZ  
 6 LOOKS°BEST°COMPRESSED°° 123456789  
 7 AßCÐEFGHIJKLMNOPQRSTUVWXYZ  
 8 a b e d e f g h i j k l m n o p q r s t u v w x y z 1 2 3 . 4 5 6 7 8 9  
 9 Ꝛ ꝛ Ꝝ ꝝ Ꝟ ꝟ Ꝡ ꝡ Ꝣ ꝣ Ꝥ ꝥ Ꝧ ꝧ Ꝩ ꝩ Ꝫ ꝫ Ꝭ ꝭ Ꝯ ꝯ ꝰ ꝱ ꝲ ꝳ ꝴ ꝵ ꝶ ꝷ ꝸ Ꝺ ꝺ  
 10 ꝰ ꝱ ꝲ ꝳ ꝴ ꝵ ꝶ ꝷ ꝸ Ꝺ ꝺ ꝛ Ꝝ ꝝ Ꝟ ꝟ Ꝡ ꝡ Ꝣ ꝣ Ꝥ ꝥ Ꝧ ꝧ Ꝩ ꝩ Ꝫ ꝫ Ꝭ ꝭ Ꝯ ꝯ ꝰ ꝱ ꝲ ꝳ ꝴ ꝵ ꝶ ꝷ ꝸ Ꝺ ꝺ  
 11 SIMPLE METHODS SUITABLE FOR  
 12 EMBELLISHING PLAIN LETTERS

Fig. 63

rapid work. The single stroke inclined Gothic being the one most easily understood and acquired is the style best adapted for the beginner's first attempt. It illustrates all the cardinal principles of good lettering and it is but a step from this to the Roman, thence to other more elaborate forms. See an analysis of it in detail under the topic, "Directions for Practice Work."

The letters shown in **Fig. 59**, lines 9 and 10, are adapted to either free-hand or mechanical construction, but especially the latter as there are no curved parts. Lower case letters of the same style may be used, but they are not satisfactory from the standpoint of appearance and economy of time. Note that the heavy shading is on the top and bottom horizontals only.

In lines 1 and 2, **Fig. 63**, we have the vertical Roman. These letters must be formed with considerable care if they are to be presentable. Lack of parallelism, either in the general outlines or in the edges of shaded parts detracts much. The serifs, too, must curve very nicely into the parts they terminate. If they are tilted, the result is markedly offensive. The letters in lines 3 and 4, **Fig. 63**, have already been referred to as modifications of the Roman letter suited to off-hand work.

While most styles of letters look well in the vertical, forward or back slant position, those shown in lines 5 to 10, **Fig. 63**, are satisfactory only when vertical. They are free in style, easily made, and as such, well adapted to architectural drawings. Those shown in line 5 look best compressed. Of the three, that given in lines 7 and 8 permits most rapid work.

In lines 11 and 12, **Fig. 63**, are indicated some of the possibilities in the way of adorning so plain a letter as the Gothic. The simpler the treatment the more pleasing the result. Many other modifications will suggest themselves and for those who lack originality, a look through the magazine advertisers may afford inspiration.

**297. Old English, Fig. 64**, is used chiefly for engrossing diplomas, certificates of membership and similar documents. **Round Writing**, not given here, has been used to some extent for working drawings, but though it can be rapidly made, looks well and is easily learned, its lack of legibility has prevented its general adoption.



A B C D E F G H I J K L M  
 N O P Q R S T U V W X Y Z &  
 a b c d e f g h i j k l m n o p q r s t  
 u v w x y z 1 2 3 4 5 6 7 8 9 0

6 Point

8 Point

10 Point

12 Point

14 Point

18 Point

24 Point

30 Point

36 Point

Fig. 64

## TITLES

**298. General Character.** A general title contains the principal information necessary to identify the drawing with the matter represented. Its **location** will vary according to the character of the drawing, being most frequently in the lower right hand corner. The **size of title space** depends on the size of sheet, those given in **Fig. 65** being appropriate for sheets up to 18" x 24" in size. For a sheet 24" x 36", the title and letter dimensions could be increased 50% or more. The **shape of title space** is determined by the kind of drawing and the contents of the title, but it is usually rectangular with the long dimension horizontal. Its **arrangement** will be symmetrical with respect to a vertical center line. **Vertical letters** produce the best effect in a title and a mixture of vertical and inclined letters is not satisfactory. The **size of letters and spaces between** lines should be so selected that the title will appear well balanced or distributed over the space. The several **parts of the title may be lettered to correspond to their importance**, proper prominence being obtained by judicious use of different sizes and styles. See **Fig. 65**, titles 1 and 2. Let the **style of letters** be appropriate to the character of the drawing; the fewer the styles in one title the better.

**299. Titles for Working Drawings.** The title for a working drawing will specify the name of the machine or structure represented and generally the groups of parts to which the sheet is devoted. If the machine or structure is for some special use or location, it is often so stated. To this is added the name and location of the makers, the scale and date of the drawing, with the name or initials of the draftsman who made it. In many titles, spaces are left for the signature, by initials only, of those who trace, check and approve the drawing. Occasionally we find the name of the designer attached. The job or order number is also often placed in the title. Title 1 of **Fig. 65** is a form suitable for working drawings. Titles for this class of drawings are almost invariably placed in the lower right hand corner close up to the border. They can then be referred to conveniently when filed in a drawer with many others. Every drafting office has its own standard title form and this is of such shape and size as will meet its special needs. Though fanciful lettering is sometimes found on commercial drawings, the general tendency is toward extreme

**No. 6 PLAIN GRIND. MACHINE**  
**DETAILS OF REVERSING GEAR**

SCALE FULL SIZE  
THE WASHBURN SHOPS

WORCESTER MASS.      JUNE 12 1905

DRAWN BY ----- CHECKED BY -----

TRACED BY ----- APPROVED -----

**MAP OF**

**THE WORLD**

**ON MERCATOR'S PROJECTION**

SHOWING OCEAN CURRENTS  
AND TRADE ROUTES

THE INTERNATIONAL  
COMPETITION FOR THE  
ARCHITECTURAL PLAN  
FOR THE UNIVERSITY  
OF CALIFORNIA 1899

simplicity. The plain Gothic, either heavy face or single stroke, is the prevalent style employed and the largest letters will rarely exceed  $\frac{7}{16}$ " in height.

**300. Map Titles.** The title of a map or plan specifies the locality represented, the scale and date of the drawing, name of the draftsman and usually the name of the surveyor or engineer. If the drawing has been made for a public commission or corporation, it is customary to include the name. The location, size and shape of the title will be determined by the available space outside of or even on the map. A uniform arrangement for a series is not generally possible unless a one- or two-line title is used. Roman and Gothic letters, plain or simply modified, are the ones commonly used, but it is quite permissible to arrange them to produce an ornamental effect. Title 2, **Fig. 65**, will illustrate this. It also shows how to grade the prominence of different parts of the title. For instance, "The World" if in solid black would give too heavy, while if in outline only it would give too light an effect. As the most important part of the title it has larger letters.

**301. Architectural Titles.** Titles for architectural drawings follow no rule, but are treated with great freedom. In the majority of cases, such a title will designate "what" and "where" regarding the matter represented, also the scale of the drawing. It may or may not have the date, name of the architect, draftsman or other useful information. Its location is as variable as its contents and it is liable to be placed anywhere, even on the face of the drawing if such an arrangement is feasible. The size is usually such as to make it inconspicuous. In fact, it is often made to resemble a formal title as little as possible. As to shape, the rectangular is most common and the long dimension will frequently be vertical, especially if the style be that shown in title 3, **Fig. 65**. In this form the rectangle is to be filled as completely as possible without reference to punctuation or the division and spacing of words. Outline Roman, Old Roman and the styles shown in lines 5 to 8, **Fig. 63**, are the ones most used.

**302. Laying out Titles.** To locate symmetrically a line of letters in a title gives beginners some trouble. If the letters are pencilled first, they can be located by trial, but this is apt to be a tedious process if the line be a long one or the letters other than the simplest. Consider for example in title 2, **Fig. 65**,

1 2 3 4 5 6 7 8 9 10 11 12 13 14 15 16 17 18 19 20 21 22 23

the line, O N M E R C A T O R ' S P R O J E C T I O N. Numbering from the left and counting a space be-

tween words as equivalent to a letter there are seen to be 23 letters and spaces. If letter widths were all normal, number 12, the S in Mercator's would be at the middle of the line. But as there is a wide letter, number 4, and a wide space for the apostrophe at the left of the S, while at the right are two narrow letters, numbers 17 and 21, it is necessary to shift the center of the line a little to the left of the S. Starting then with the S properly placed, work both ways from the center. If appearances indicate that the end letters are not coming just right, a slight modification in letter and space widths will overcome the error as the work proceeds. It will be easier for some to first mark off in pencil the space allotted to each letter. On account of the difficulty of proper placing, it is advisable for beginners to pencil titles before inking, until the eye is sufficiently trained to dispense with it.

### DIRECTIONS FOR PRACTICE WORK

**303.** Smooth, hard surface paper is the best for lettering as it helps insure a clean cut line and smooth working of the pen. This is quite desirable when lettering for reproduction. When tracing cloth is used, the surface must be thoroughly rubbed with powdered chalk or pumice and all particles removed before the ink is applied.

**304.** A fine pen like a Gillott Lithographic is best for Roman letters and others having fine lines and shaded parts. For single stroke Gothic, a medium fine pen that has been somewhat used or a fine ball point pen will work well. The prudent draftsman will take good care of his lettering pen, using it for no other purpose. It should be cleaned frequently, as ink particles collect and dry between the nibs, spreading them so as to render the pen useless. Water-proof black ink is most used.

**305.** The upper and lower **guide lines are always pencilled** and to save time in practice, cross-section paper ruled in tenths of an inch may be used. **Slant lines in pencil showing the inclination** may be ruled in intervals all over the sheet. A rise of 5 on a base of 2 is a very good inclination to use. Tack the sheet on the board in such a way that the elbow is supported when at work, otherwise the motion will be cramped.



Fig. 66

306. Practice first the strokes shown in Fig. 66, taking them in order. They will assist in acquiring the necessary swing. Blackboard practice on these is very beneficial. It is needless to say, that at first, **the mind must be concentrated on the pen point from the start to the completion of a stroke.** After considerable practice, it will be possible to letter automatically just as we write, but until that time it is well to remember that **lettering is a mind as well as a hand exercise.**

307. Turning now to the alphabet of **capitals** in Fig. 59, lines 1 to 6, make two or three copies of each letter and figure. Before making a letter, note carefully in each case its general **shape** and **proportions.** The horizontal lines and enclosing parallelograms will assist in this. The parallelograms should always be sketched in pencil if the letter gives trouble as is generally the case with those having oblique parts like A, K, etc.

308. Next study the **sequence of strokes** as shown in lines 2, 3, 5 and 6. Where two methods are given the first is desirable for rapid work, but if the beginner does not master it at once, let him try the second. Other ways than those given may be used if they produce good results. After going through the capitals in this fashion, look over the work critically, mark the letters with which you have had the least success and devote extra practice to them. It may be said here that **the enjoyable way to learn to letter** is not to practice half a day at a time once a month, but rather to spend a quarter-hour each day. Practice on the letters by groups is also desirable. Thus the A K M N V W X Y Z may be classed as the ones with predominating oblique parts, the B D E F H L P R T as the ones with horizontal parts, while C, G, O and Q belong to the ovals, leaving the I, J and S as miscellaneous. Attention has been directed to the I, J, M and W as **letters of abnormal width.** Other peculiarities should be noticed as follows. The mid-horizontal parts of the A and G and the intersection point in the Y are the same height, a little below the middle. The corresponding parts in the B E F H R and X are slightly above the middle while in the P it is at the middle. The upper lobe in the B and the S is slightly smaller than the lower one. Invert the letters to see it plainly. The lower oblique part of the K if extended will intersect the top end

of the upright part. The M and W must be carefully distinguished as it is a common error for a student to make an M like an inverted W, and vice versa. Among the figures, the upper part in the 3 and 8 is smaller than the lower. The 9 is the 6 inverted and the general outline of each coincides with that of the zero.

**309.** Lower case letters are to be practiced in the same way as the capitals. Those of abnormal width, the f i j l m r t and w, have already been mentioned. In the a b c d e g o p q are ovals and straight parts, in the f h j m and n are hooks and straight parts while the u v w x and z are like their capitals. Note that the cross-piece for the f and t is on a level with the tops of the short letters and that the upper oblique part of the k terminates at the same height.

**310.** When an ink line is led out of another not dry and the angle is small, a blot may form at the notch as is indicated in **Fig. 67**. Such blotting as shown in the word "pen" may be avoided by carrying less ink on the pen or by breaking up the stroke as is shown in the second part of the same figure. **The principle is to lead into but not out of a wet line.** This blotting is less liable in the Reinhardt letter than in the single stroke Gothic.

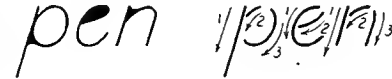

Fig. 67

**311.** If the beginner has no immediate success with letters of normal width, let him try the extended form, making his width equal to or greater than the height.

**312.** The prominence of poor lettering may sometimes be reduced by heavy underlining.

**313.** Practice lettering in pencil is not advisable when ink is at hand as it permits thoughtless work on account of being so easily corrected.

**314.** It is useless to attempt free-hand lettering with chilled hands or immediately after severe muscular exertion.

## LETTERING FOR PHOTO REPRODUCTION

**315.** A drawing may be reduced even to microscopic size by photography, but the chemical and mechanical manipulation necessary in producing the metal plate used for printing imposes some limits.

For many drawings, it is desirable to have the final print smaller than the original because the unavoidable irregularities of free-hand work are thereby reduced in prominence. Some draftsmen, however, prefer little or no reduction because the effect of the original may be materially changed. The amount of reduction possible is really decided by the width of the finest lines, as beyond a certain point they will become broken in the plate. A reduction to  $\frac{1}{2}$  or  $\frac{1}{3}$  the linear dimensions of the original is a good one, suitable for the width of medium weight pen strokes. **Fig. 65** is of the same size as the original, **Figs. 59 and 63** are  $\frac{1}{2}$  the linear dimensions of the original while the cuts in the text of this chapter are  $\frac{2}{5}$ . A reduction to a size less than that of six point type used in this sentence will generally be unsatisfactory on the score of legibility. For the same reason the spacing for very small letters should be more open. Notches and small loops have a tendency to fill when the

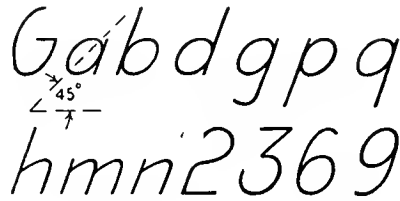

Fig. 68

letters are small and it was to avoid this that the **Reinhardt letter** was evolved and is used on its cuts by the "Engineering News." It is only a slight modification of the single stroke Gothic and all the letters which differ materially are shown in **Fig. 68**. The principal variation is in the slant of the ovals which is about  $45^\circ$  as indicated, while in the Gothic letter the corresponding slant would be about  $60^\circ$ . Compare with line 7, **Fig. 59**. Another variation is in the hooks of letters such as the h, m and n where the hook is made more pointed and leads from the straight stem at a greater angle. Loops are also exaggerated as in the e. The upper and lower parts

of the 2, 3, 6 and 9 are more nearly the same size.

**316.** Waterproof black ink is the best to use for reduction work as there is no danger of blurring it by accidental moistening. All ink lines must be jet black, never grayish. Red coloring matter is sometimes put in the ink to insure its photographing properly. For the same photographic reason the paper used should be of a bluish rather than of a yellowish tinge.

## ALTERATIONS

**317.** Often a letter or part of one must be removed. The use of an ink eraser is apt to demolish parts of neighboring letters, but it will leave a better surface for re-inking than will a sharp knife. It is



best to pencil what is to be replaced and then use very little ink on the pen, otherwise the lines may have frayed edges. If a small part is to be removed, a sharp knife will be most satisfactory. First cut lightly the surface of the paper at the boundary of the erasure, being careful not to cut through. Then scrape carefully up to the edge of this cut and you will leave a sharp clean edge on the ink line. If the surface is such as would be spoiled by erasure, the parts can be painted over with "chinese white" and ink applied on this.

### BOOKS ON LETTERING

#### 318. Text Books for Students

- Lettering for Draftsmen.* C. W. Reinhardt. Text 32 pages. 9 Plates. D. Van Nostrand Co.
- The Theory and Practice of Lettering.* C. E. Sherman. Text 49 pages. 10 Plates. Midland Publishing Co.
- Free-hand Lettering.* V. T. Wilson. Text 95 pages. 23 Plates. John Wiley & Sons.
- Text-Book on Plain Lettering.* H. S. Jacoby. Text 82 pages. 48 Plates. The Engineering News Publishing Co.
- Free-Hand Lettering.* F. T. Daniels. Text 34 pages. 13 Plates. D. C. Heath & Co.
- The Essentials of Lettering.* T. E. French and R. Meiklejohn. Text 94 pages. 120 illustrations. McGraw-Hill Book Co.

#### Lettering as a Decorative Art

- Letters and Lettering.* F. C. Brown. Text 214 pages. 211 illustrations. Bates & Guild Co.
- Alphabets.* E. F. Strange. Text 294 pages. 197 illustrations. Geo. Bell & Sons.  
Contains also a good list of references.
- Alphabets Old and New.* L. F. Day. Text 256 pages. 254 illustrations. Charles Scribner's Sons.
- Grammar of Lettering.* A. W. Lyons. Text 109 pages. 93 Plates. Maclaren & Co.

### Decimal Equivalents of Common Fractions

$\frac{1}{8}$	.125	$\frac{3}{8}$	.375
$\frac{1}{4}$	.25	$\frac{1}{2}$	.5
$\frac{3}{8}$	.375	$\frac{5}{8}$	.625
$\frac{1}{2}$	.5	1	1.0
$\frac{5}{8}$	.625	$\frac{3}{4}$	.75
$\frac{3}{4}$	.75	$\frac{7}{8}$	.875
$\frac{7}{8}$	.875	1	1.0
1	1.0		
$\frac{1}{16}$	.0625	$\frac{1}{8}$	.125
$\frac{1}{8}$	.125	$\frac{3}{16}$	.1875
$\frac{3}{16}$	.1875	$\frac{1}{4}$	.25
$\frac{1}{4}$	.25	$\frac{5}{16}$	.3125
$\frac{5}{16}$	.3125	$\frac{3}{8}$	.375
$\frac{3}{8}$	.375	$\frac{7}{16}$	.4375
$\frac{7}{16}$	.4375	$\frac{1}{2}$	.5
$\frac{1}{2}$	.5	$\frac{9}{16}$	.5625
$\frac{9}{16}$	.5625	$\frac{5}{8}$	.625
$\frac{5}{8}$	.625	$\frac{11}{16}$	.6875
$\frac{11}{16}$	.6875	$\frac{3}{4}$	.75
$\frac{3}{4}$	.75	$\frac{13}{16}$	.8125
$\frac{13}{16}$	.8125	$\frac{7}{8}$	.875
$\frac{7}{8}$	.875	$\frac{15}{16}$	.9375
$\frac{15}{16}$	.9375	1	1.0
1	1.0		
$\frac{1}{32}$	.03125	$\frac{1}{16}$	.0625
$\frac{1}{16}$	.0625	$\frac{3}{32}$	.09375
$\frac{3}{32}$	.09375	$\frac{1}{8}$	.125
$\frac{1}{8}$	.125	$\frac{5}{32}$	.15625
$\frac{5}{32}$	.15625	$\frac{3}{16}$	.1875
$\frac{3}{16}$	.1875	$\frac{7}{32}$	.21875
$\frac{7}{32}$	.21875	$\frac{1}{4}$	.25
$\frac{1}{4}$	.25	$\frac{9}{32}$	.28125
$\frac{9}{32}$	.28125	$\frac{5}{16}$	.3125
$\frac{5}{16}$	.3125	$\frac{11}{32}$	.34375
$\frac{11}{32}$	.34375	$\frac{3}{8}$	.375
$\frac{3}{8}$	.375	$\frac{13}{32}$	.40625
$\frac{13}{32}$	.40625	$\frac{7}{16}$	.4375
$\frac{7}{16}$	.4375	$\frac{15}{32}$	.46875
$\frac{15}{32}$	.46875	$\frac{1}{2}$	.5
$\frac{1}{2}$	.5		

### WHITNEY KEYS

### WOODRUFF'S SYSTEM

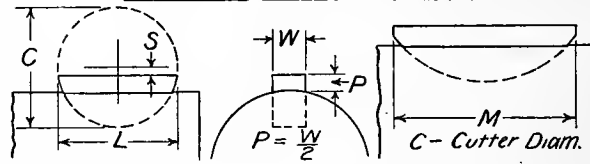

No.	C	W	P	S	L	No.	C	W	P	S	L
1	$\frac{1}{8}$	$\frac{1}{8}$	$\frac{1}{8}$	$\frac{3}{8}$	$\frac{1}{2}$	22	$\frac{1}{8}$	$\frac{1}{4}$	$\frac{1}{8}$	$\frac{3}{8}$	$\frac{1}{8}$
2	$\frac{1}{8}$	$\frac{3}{16}$	$\frac{3}{16}$	$\frac{3}{8}$	$\frac{1}{2}$	23	$\frac{1}{8}$	$\frac{1}{4}$	$\frac{5}{16}$	$\frac{3}{8}$	$\frac{1}{8}$
3	$\frac{1}{8}$	$\frac{1}{8}$	$\frac{1}{8}$	$\frac{3}{8}$	$\frac{1}{2}$	F	$\frac{1}{8}$	$\frac{3}{8}$	$\frac{3}{8}$	$\frac{3}{8}$	$\frac{1}{8}$
4	$\frac{1}{8}$	$\frac{5}{16}$	$\frac{5}{16}$	$\frac{1}{4}$	$\frac{1}{2}$	24	$\frac{1}{8}$	$\frac{1}{4}$	$\frac{1}{8}$	$\frac{7}{8}$	$\frac{1}{2}$
5	$\frac{1}{8}$	$\frac{3}{8}$	$\frac{3}{8}$	$\frac{1}{4}$	$\frac{1}{2}$	25	$\frac{1}{2}$	$\frac{1}{4}$	$\frac{5}{8}$	$\frac{7}{8}$	$\frac{1}{2}$
6	$\frac{1}{8}$	$\frac{5}{8}$	$\frac{5}{8}$	$\frac{1}{4}$	$\frac{1}{2}$	G	$\frac{1}{2}$	$\frac{1}{4}$	$\frac{3}{8}$	$\frac{7}{8}$	$\frac{1}{2}$
7	$\frac{1}{8}$	$\frac{3}{4}$	$\frac{3}{4}$	$\frac{1}{4}$	$\frac{1}{2}$						
8	$\frac{1}{8}$	$\frac{7}{8}$	$\frac{7}{8}$	$\frac{1}{4}$	$\frac{1}{2}$	No.	C	W	P	S	M
9	$\frac{1}{8}$	1	1	$\frac{1}{4}$	$\frac{1}{2}$	26	$\frac{21}{32}$	$\frac{3}{8}$	$\frac{3}{8}$	$\frac{17}{32}$	$\frac{13}{32}$
10	$\frac{1}{8}$	$\frac{9}{8}$	$\frac{9}{8}$	$\frac{1}{4}$	$\frac{1}{2}$	27	$\frac{21}{32}$	$\frac{1}{4}$	$\frac{5}{8}$	$\frac{17}{32}$	$\frac{13}{32}$
11	$\frac{1}{8}$	$\frac{7}{8}$	$\frac{7}{8}$	$\frac{1}{4}$	$\frac{1}{2}$	28	$\frac{21}{32}$	$\frac{1}{8}$	$\frac{3}{8}$	$\frac{17}{32}$	$\frac{13}{32}$
12	$\frac{1}{8}$	$\frac{7}{8}$	$\frac{7}{8}$	$\frac{1}{4}$	$\frac{1}{2}$	29	$\frac{21}{32}$	$\frac{3}{8}$	$\frac{1}{16}$	$\frac{17}{32}$	$\frac{13}{32}$
A	$\frac{1}{8}$	$\frac{7}{8}$	$\frac{7}{8}$	$\frac{1}{4}$	$\frac{1}{2}$	R	$\frac{21}{32}$	$\frac{1}{4}$	$\frac{1}{8}$	$\frac{17}{32}$	$\frac{13}{32}$
13	1	$\frac{3}{8}$	$\frac{3}{8}$	$\frac{1}{4}$	1	S	$\frac{21}{32}$	$\frac{1}{4}$	$\frac{5}{8}$	$\frac{17}{32}$	$\frac{13}{32}$
14	1	$\frac{3}{8}$	$\frac{3}{8}$	$\frac{1}{4}$	1	T	$\frac{21}{32}$	$\frac{1}{8}$	$\frac{5}{8}$	$\frac{17}{32}$	$\frac{13}{32}$
15	1	$\frac{1}{4}$	$\frac{1}{4}$	$\frac{1}{4}$	1	U	$\frac{21}{32}$	$\frac{7}{8}$	$\frac{1}{16}$	$\frac{17}{32}$	$\frac{13}{32}$
B	1	$\frac{1}{16}$	$\frac{1}{16}$	$\frac{1}{4}$	1	V	$\frac{21}{32}$	$\frac{1}{2}$	$\frac{1}{4}$	$\frac{17}{32}$	$\frac{13}{32}$
16	$\frac{1}{8}$	$\frac{3}{8}$	$\frac{3}{8}$	$\frac{1}{4}$	$\frac{1}{8}$	30	$\frac{31}{32}$	$\frac{3}{8}$	$\frac{1}{8}$	$\frac{13}{16}$	$\frac{21}{32}$
17	$\frac{1}{8}$	$\frac{7}{16}$	$\frac{7}{16}$	$\frac{1}{4}$	$\frac{1}{8}$	31	$\frac{31}{32}$	$\frac{7}{16}$	$\frac{7}{16}$	$\frac{13}{16}$	$\frac{21}{32}$
18	$\frac{1}{8}$	$\frac{1}{4}$	$\frac{1}{4}$	$\frac{1}{4}$	$\frac{1}{8}$	32	$\frac{31}{32}$	$\frac{1}{2}$	$\frac{1}{4}$	$\frac{13}{16}$	$\frac{21}{32}$
C	$\frac{1}{8}$	$\frac{1}{16}$	$\frac{1}{16}$	$\frac{1}{4}$	$\frac{1}{8}$	33	$\frac{31}{32}$	$\frac{1}{2}$	$\frac{9}{16}$	$\frac{13}{16}$	$\frac{21}{32}$
19	$\frac{1}{4}$	$\frac{3}{16}$	$\frac{3}{16}$	$\frac{1}{4}$	$\frac{1}{4}$	34	$\frac{31}{32}$	$\frac{5}{8}$	$\frac{5}{16}$	$\frac{13}{16}$	$\frac{21}{32}$
20	$\frac{1}{4}$	$\frac{7}{16}$	$\frac{7}{16}$	$\frac{1}{4}$	$\frac{1}{4}$	35	$\frac{31}{32}$	$\frac{1}{4}$	$\frac{1}{32}$	$\frac{13}{16}$	$\frac{21}{32}$
21	$\frac{1}{4}$	$\frac{1}{4}$	$\frac{1}{4}$	$\frac{1}{4}$	$\frac{1}{4}$	36	$\frac{31}{32}$	$\frac{3}{4}$	$\frac{3}{8}$	$\frac{13}{16}$	$\frac{21}{32}$
D	$\frac{1}{4}$	$\frac{5}{16}$	$\frac{5}{16}$	$\frac{1}{4}$	$\frac{1}{4}$						
E	$\frac{1}{4}$	$\frac{3}{8}$	$\frac{3}{8}$	$\frac{1}{4}$	$\frac{1}{4}$						

### U.S. STANDARD BOLTS AND NUTS

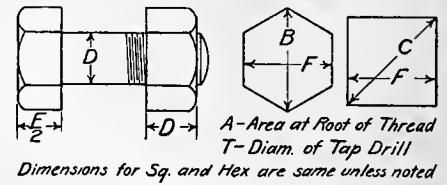

Dia.	Thd.	B	C	F	T	A
$\frac{1}{4}$	20	$\frac{3}{16}$	$\frac{3}{8}$	$\frac{1}{2}$	$\frac{13}{16}$	.0260
$\frac{5}{16}$	18	$\frac{11}{16}$	$\frac{3}{8}$	$\frac{9}{16}$	$\frac{1}{4}$	.0452
$\frac{3}{8}$	16	$\frac{5}{8}$	$\frac{3}{8}$	$\frac{1}{16}$	$\frac{9}{16}$	.0677
$\frac{7}{8}$	14	$\frac{3}{4}$	$\frac{7}{8}$	$\frac{1}{16}$	$\frac{3}{4}$	.0932
$\frac{1}{2}$	13	$\frac{11}{16}$	$\frac{1}{2}$	$\frac{1}{4}$	$\frac{13}{16}$	.1257
$\frac{9}{16}$	12	$\frac{11}{8}$	$\frac{1}{8}$	$\frac{3}{16}$	$\frac{5}{8}$	.1620
$\frac{5}{8}$	11	$\frac{11}{8}$	$\frac{1}{2}$	$\frac{1}{16}$	$\frac{3}{4}$	.2018
$\frac{3}{4}$	10	$\frac{11}{4}$	$\frac{5}{8}$	$\frac{1}{4}$	$\frac{5}{8}$	.3020
$\frac{7}{8}$	9	$\frac{11}{4}$	$\frac{3}{4}$	$\frac{1}{16}$	$\frac{4}{7}$	.4194
1	8	$\frac{11}{4}$	$\frac{3}{4}$	$\frac{1}{8}$	$\frac{2}{3}$	.5509
$\frac{11}{8}$	7	$\frac{23}{8}$	$\frac{9}{16}$	$\frac{11}{8}$	$\frac{61}{64}$	.6930
$\frac{11}{4}$	7	$\frac{23}{4}$	$\frac{3}{4}$	2	$\frac{15}{16}$	.8890
$\frac{13}{8}$	6	$\frac{23}{4}$	$\frac{3}{4}$	$\frac{23}{8}$	$\frac{111}{64}$	1.054
$\frac{11}{2}$	6	$\frac{23}{2}$	$\frac{3}{4}$	$\frac{23}{4}$	$\frac{119}{64}$	1.293
$\frac{13}{4}$	5	$\frac{31}{16}$	$\frac{3}{4}$	$\frac{23}{4}$	$\frac{133}{64}$	1.744
2	4 $\frac{1}{2}$	$\frac{33}{8}$	$\frac{47}{4}$	$\frac{31}{4}$	$\frac{133}{32}$	2.30
$\frac{21}{4}$	4 $\frac{1}{2}$	$\frac{43}{4}$	$\frac{461}{4}$	$\frac{31}{2}$	$\frac{131}{32}$	3.021
$\frac{21}{2}$	4	$\frac{43}{2}$	$\frac{531}{4}$	$\frac{31}{8}$	$\frac{21}{16}$	3.714
$\frac{21}{4}$	4	$\frac{43}{2}$	$\frac{611}{4}$	$\frac{41}{4}$	$\frac{21}{8}$	4.618
3	3 $\frac{1}{2}$	$\frac{51}{2}$	$\frac{611}{2}$	$\frac{41}{2}$	$\frac{21}{4}$	5.427

Table No. 1

## HEXAGON AND SQUARE HEAD CAP SCREWS

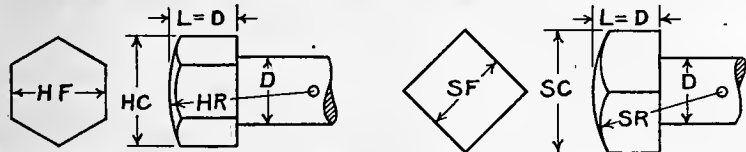

## SET SCREWS

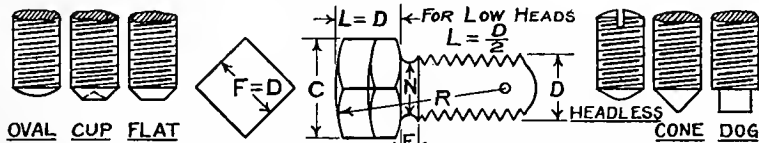

D-DIAM.	1/4	5/16	3/8	7/16	1/2	9/16	5/8	3/4	7/8	1	1 1/8	1 1/4
HC	1/2	31/64	21/32	23/32	55/64	15/16	11/64	15/32	11/64	11/16	119/32	147/64
HF	7/16	1/2	9/16	5/8	3/4	13/16	7/8	1	1 1/8	1 1/4	1 3/8	1 1/2
HR	21/32	3/4	27/32	15/16	1 1/8	1 1/32	1 1/16	1 1/2	1 1/16	1 1/8	2 1/16	2 1/4
SC	11/32	5/8	45/64	51/64	5 5/64	31/32	1 1/16	1 13/64	1 19/32	1 49/64	1 15/16	2 1/8
SF	3/8	7/16	1/2	9/16	5/8	11/16	3/4	7/8	1 1/8	1 1/4	1 3/8	1 1/2
SR	3/16	21/32	3/4	27/32	15/16	1 1/32	1 1/8	1 5/16	1 11/16	1 7/8	2 1/16	2 1/4
THREAD	20	18	16	14	13	12	11	10	9	8	7	7

D-DIAM.	1/4	5/16	3/8	7/16	1/2	9/16	5/8	3/4	7/8	1	1 1/8	1 1/4
C	23/64	7/16	17/32	5/8	45/64	51/64	57/64	1 1/16	1 15/64	1 3/32	1 19/32	1 47/64
R	5/8	25/32	15/16	1 1/32	1 1/4	1 13/32	1 1/16	1 1/8	2 1/16	2 1/2	2 3/16	3 1/8
E	5/64	5/64	3/32	1/64	1/8	1/8	1/8	5/32	11/64	3/16	13/64	7/32
N	1/32	17/64	21/64	3/8	7/16	31/64	33/64	21/32	49/64	7/8	1	1 1/8

THREAD	20	18	16	14	13	12	11	10	9	8	7	7
1/2												
5/8												
3/4												
7/8												
1												
1 1/4												
1 1/2												
1 3/4												
2												
2 1/4												
2 1/2												
2 3/4												
3												
3 1/4												
3 1/2												
3 3/4												
4												
4 1/4												
4 1/2												
4 3/4												
5												

LENGTH UNDER HEAD TO EXTREME POINT	3/4	1/8	1	1 1/4	1 1/2	1 3/4	2	2 1/4	2 1/2	2 3/4	3	3 1/4	3 1/2	3 3/4	4	4 1/4	4 1/2	4 3/4	5
3/4																			
1/8																			
1																			
1 1/4																			
1 1/2																			
1 3/4																			
2																			
2 1/4																			
2 1/2																			
2 3/4																			
3																			
3 1/4																			
3 1/2																			
3 3/4																			
4																			
4 1/4																			
4 1/2																			
4 3/4																			
5																			

## FILLISTER HEAD CAP SCREWS

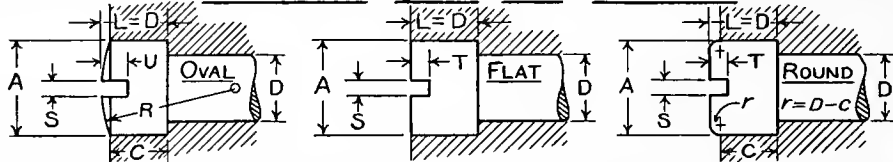

D-DIAM.	1/8	3/16	1/4	5/16	3/8	7/16	1/2	9/16	5/8	3/4	7/8	1
A	3/16	1/4	3/8	7/16	9/16	5/8	3/4	13/16	7/8	1	1 1/8	1 1/4
C	7/64	5/32	1/32	17/64	21/64	3/8	27/64	31/64	35/64	21/32	49/64	7/8
R	1/4	5/16	1/2	5/8	3/4	7/8	1	1 1/8	1 1/4	1 1/2	1 5/8	1 3/4
S	.032	.040	.064	.072	.091	.102	.114	.114	.128	.133	.133	.165
T	1/16	1/16	1/16	5/64	3/32	7/64	1/8	9/64	5/32	3/16	7/32	1/4
U	5/64	3/32	3/32	1/8	9/64	1/64	3/16	7/32	15/64	9/32	21/64	3/8
THREAD	40	32	20	18	16	14	13	12	11	10	9	8

LENGTH UNDER HEAD TO EXTREME POINT	3/4											
	1											
	1 1/4											
	1 1/2											
	1 3/4											
	2											
	2 1/4											
	2 1/2											
	2 3/4											
	3											
	3 1/4											
	3 1/2											
	3 3/4											
4												
4 1/4												
4 1/2												
4 3/4												
5												
5 1/4												
5 1/2												
5 3/4												
6												

## BUTTON AND COUNTERSUNK HEAD CAP SCREWS

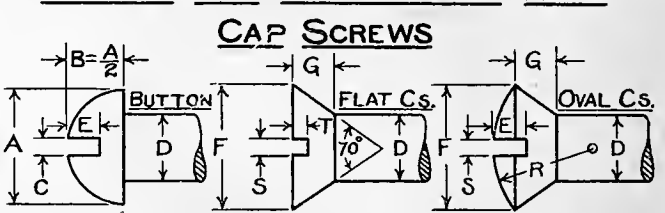

D-DIAM.	1/8	3/16	1/4	5/16	3/8	7/16	1/2	9/16	5/8	3/4
A	7/32 <sup>+</sup>	5/16	7/16	9/16	5/8	3/4	13/16	15/16	1	1 1/4
C	.035	.051	.072	.091	.102	.114	.114	.114	.133	.133
E	1/16	3/32	1/8	5/32	3/16	7/32	1/4	9/32	5/16	3/8
F	1/4	3/8	15/32	5/8	3/4	13/16	7/8	1	1 1/8	1 3/8
G	3/32	9/64	3/32	1/32	17/64	17/64	17/64	5/16	23/64	7/16
R	3/16	9/32	3/8	15/32	9/16	21/32	3/4	27/32	15/16	1 1/8
S	.040	.064	.072	.102	.114	.114	.128	.133	.133	.133
T	3/64	3/64	1/16	5/64	3/32	3/32	3/32	7/64	1/8	5/32
THREAD	40	32	20	18	16	14	13	12	11	10

  

LENGTH (SEE NOTE)	3/4									
	1									
	1 1/4									
	1 1/2									
	1 3/4									
	2									
	2 1/4									
	2 1/2									
	2 3/4									
	3									

*Note*- Dotted lines show variation for Countersunk Screws.  
*Note*- Length of Button Head Screw is under Head.  
 Length of Countersunk Head Screw is over All.

Table No. 3.

## COLLAR SCREWS

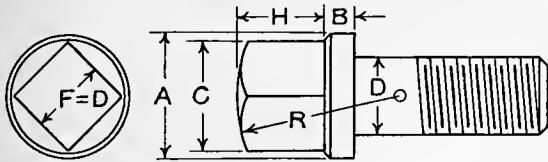

D-DIAM.	1/8	3/16	1/4	5/16	3/8	7/16	1/2	9/16	5/8	3/4
A	1/4	1/32	7/16	1/2	5/8	1 1/16	1 3/16	1 5/16	1	1 1/4
B	1/16	3/64	3/32	1/8	5/32	3/16	13/64	7/32	1/4	5/16
C	1/64	1/64	23/64	1/16	17/32	9/8	45/64	5/64	5/64	1 1/16
H	3/64	7/32	9/32	1/32	13/32	15/32	9/16	5/8	1/16	13/16
R	1/4	3/8	1/2	1 1/16	1 3/16	1 5/16	1 1/16	1 3/16	1 5/16	1 9/16
THREAD	40	32	20	18	16	14	13	12	11	10

LENGTH UNDER HEAD TO EXTREME POINT	3/2									
	1									
	1 1/4									
	1 1/2									
	1 3/4									
	2									
	2 1/4									
	2 1/2									
	2 3/4									
	3									
3 1/4										
3 1/2										
3 3/4										
4										
4 1/4										
4 1/2										
4 3/4										
5										

## STUDS

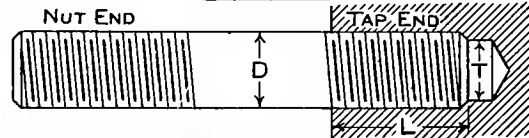

D-DIAM.	1/4	5/16	3/8	7/16	1/2	9/16	5/8	3/4	7/8	1	1 1/8	1 1/4
L MAX.	7/16	1/2	3/16	5/8	3/4	7/8	1 5/16	1 1/8	1 3/16	1 1/2	1 1/16	1 7/8
L MIN.	5/16	3/8	7/16	1/2	9/16	5/8	1 1/16	3/4	7/8	1	1 1/8	1 1/4
T-C.I.	13/64	17/64	5/16	3/8	27/64	3/64	17/32	41/64	3/4	55/64	31/32	1 3/32
THREAD	20	18	16	14	13	12	11	10	9	8	7	7

## A.L.A.M. STAND. BOLTS AND NUTS

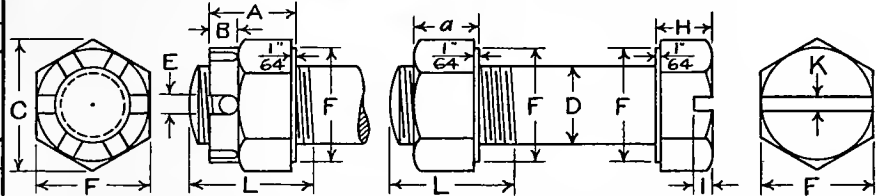

D-DIAM.	1/4	5/16	3/8	7/16	1/2	9/16	5/8	1 1/16	3/4	7/8	1
A	9/32	21/64	13/32	29/64	9/16	39/64	23/32	49/64	13/16	29/32	1
a	7/32	17/64	21/64	3/8	7/16	31/64	35/64	19/32	21/32	49/64	7/8
B	3/32	3/32	1/8	1/8	3/16	3/16	1/4	1/4	1/4	1/4	1/4
C	7/16	37/64	21/32	5/64	5/64	1/64	1/64	1 5/32	1 1/64	1 1/16	1 2/32
E	5/64	5/64	1/8	1/8	1/8	5/32	5/32	5/32	5/32	5/32	5/32
F	3/8	1/2	3/16	1/16	3/4	7/8	15/16	1	1 1/8	1 1/4	1 7/16
H	3/16	13/64	9/32	21/64	3/8	21/64	15/32	33/64	9/16	21/32	3/4
I	3/32	7/64	1/8	1/8	1/8	1/8	1/8	1/8	1/8	1/8	1/8
K	1/16	1/16	3/32	3/32	3/32	3/32	3/32	3/32	3/32	3/32	3/32
L	3/8	15/32	9/16	21/32	3/4	27/32	15/16	1 1/32	1 1/8	1 5/16	1 1/2
COT. PIN	1/16	1/16	3/32	3/32	3/32	1/8	1/8	1/8	1/8	1/8	1/8
THREAD	28	24	24	20	20	18	18	16	16	14	14

Note - Thread is U.S. Standard.

# MACHINE SCREWS A.S.M.E. STAND.

## OVAL FILLISTER HEAD

$A = \text{Diam.}$   
 $B = 1.64A - .009$   
 $C = 0.66A - .002$   
 $D = .173A + .015$   
 $E = \frac{1}{2}F$   
 $F = .734B + C$

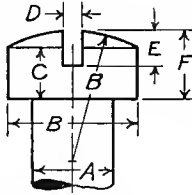

## FLAT FILLISTER HEAD

$A = \text{Diam.}$   
 $B = 1.64A - .009$   
 $C = 0.66A - .002$   
 $D = 0.173A + .015$   
 $E = \frac{1}{2}C$

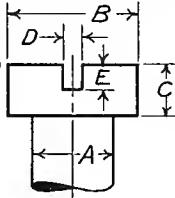

## FLAT HEAD

$A = \text{Diam.}$   
 $B = 2A - .008$   
 $C = \frac{A - .008}{1.739}$   
 $D = .173A + .015$   
 $E = \frac{1}{3}C$

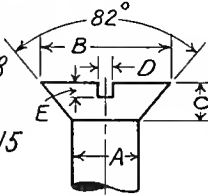

## ROUND HEAD

$A = \text{Diam.}$   
 $B = 1.85A - .005$   
 $C = 0.7A$   
 $D = .173A + .015$   
 $E = \frac{1}{2}C + .01$

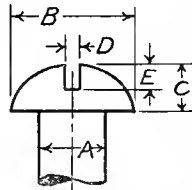

NUMBER	OUTSIDE DIAMETER	THREADS PER IN.	TAP DRILL DIAMETER
0	.060	80	.0465
1	.073	72	.0595
2	.086	64	.0700
3	.099	56	.0785
4	.112	48	.0890
5	.125	44	.0995
6	.138	40	.1100
7	.151	36	.1200
8	.164	36	.1360
9	.177	32	.1405
10	.190	30	.1520
12	.216	28	.1730
14	.242	24	.1935
16	.268	22	.2130
18	.294	20	.2340
20	.320	20	.2610
22	.346	18	.2810
24	.372	16	.2968
26	.398	16	.3230
28	.424	14	.3390
30	.450	14	.3680

T.A.S.M.E. Vol. 29 P. 99

# MACH. AND WOOD SCREW GAGE

No.	DIAM.	No.	DIAM.
000	.03152	25	.38684
00	.04468	26	.40000
0	.05784	27	.41316
1	.07100	28	.42632
2	.08416	29	.43948
3	.09732	30	.45264
4	.11048	31	.46580
5	.12364	32	.47896
6	.13680	33	.49212
7	.14996	34	.50528
8	.16312	35	.51844
9	.17628	36	.53160
10	.18944	37	.54476
11	.20260	38	.55792
12	.21576	39	.57108
13	.22892	40	.58424
14	.24208	41	.59740
15	.25524	42	.61056
16	.26840	43	.62372
17	.28156	44	.63688
18	.29472	45	.65004
19	.30788	46	.66320
20	.32104	47	.67636
21	.33420	48	.68952
22	.34736	49	.70268
23	.36052	50	.71584
24	.37368		

# TWIST DRILL AND ST. WIRE GAGE

No.	DIAM.	No.	DIAM.	No.	DIAM.
1	.2280	28	.1405	55	.0520
2	.2210	29	.1360	56	.0465
3	.2130	30	.1285	57	.0430
4	.2090	31	.1200	58	.0420
5	.2055	32	.1160	59	.0410
6	.2040	33	.1130	60	.0400
7	.2010	34	.1110	61	.0390
8	.1990	35	.1100	62	.0380
9	.1960	36	.1065	63	.0370
10	.1935	37	.1040	64	.0360
11	.1910	38	.1015	65	.0350
12	.1890	39	.0995	66	.0330
13	.1850	40	.0980	67	.0320
14	.1820	41	.0960	68	.0310
15	.1800	42	.0935	69	.02925
16	.1770	43	.0890	70	.0280
17	.1730	44	.0860	71	.0260
18	.1695	45	.0820	72	.0250
19	.1660	46	.0810	73	.0240
20	.1610	47	.0785	74	.0225
21	.1590	48	.0760	75	.0210
22	.1570	49	.0730	76	.0200
23	.1540	50	.0700	77	.0180
24	.1520	51	.0670	78	.0160
25	.1495	52	.0635	79	.0145
26	.1470	53	.0595	80	.0135
27	.1440	54	.0550		



### SQUARE FEATHER KEYS

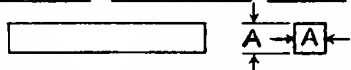

SHAFT D.	A	SHAFT D.	A
1 TO 1/8	1/4	3 1/16 TO 4 1/8	1
1 3/16	1 3/8	4 3/16	4 3/8
1 1/16	1 1/8	4 1/16	4 3/4
1 1/16	1 1/8	4 1/8	5 1/4
1 1/16	2 1/8	5 1/16	5 3/4
2 3/16	2 3/8	5 1/2	6 1/4
2 1/16	2 5/8	6 1/16	6 3/4
2 1/16	2 7/8	6 1/2	7 1/4
2 1/16	3 1/8	7 1/16	7 3/4
3 3/16	3 3/8	7 1/2	8 1/2
3 1/16	3 5/8	8 1/16	9 1/2
3 1/16	3 3/8	9 1/16	10 1/2

### STRAIGHT FLAT KEYS

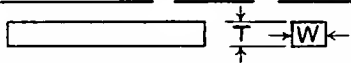

SHAFT	W	T	SHAFT	W	T
1 TO 1/8	1/4	3/16	3 1/16 TO 4 1/8	1	1/16
1 3/16	1 1/8	3/16	4 3/16	4 3/8	1 1/16
1 1/16	1 1/8	3/8	4 1/16	4 3/4	1 1/8
1 1/16	1 1/8	1/2	4 1/8	5 1/4	1 1/4
1 1/16	2 1/8	1/2	5 1/16	5 3/4	1 3/8
2 3/16	2 3/8	9/16	5 1/2	6 1/4	1 1/2
2 1/16	2 5/8	5/8	6 1/16	6 3/4	1 5/8
2 1/16	2 7/8	1 1/16	6 1/2	7 1/4	1 3/4
2 1/16	3 1/8	3/4	7 1/16	7 3/4	1 7/8
3 3/16	3 3/8	13/16	7 1/2	8 1/2	2
3 1/16	3 5/8	7/8	8 1/16	9 1/2	2 1/4
3 1/16	3 3/8	1 1/16	9 1/16	10 1/2	2 1/2

### MACHINE KNOBS

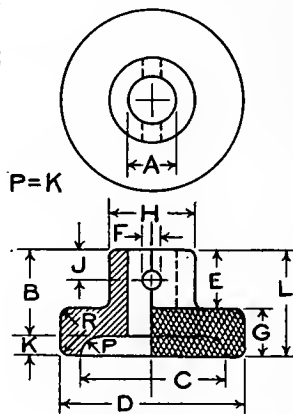

A	B	C	D	E	F	G	H	J	K	L	R
3/16	1/16	3/4	1	5/16	3/32	3/16	1/16	5/32	1/16	1/2	1/32
1/4	9/16	15/16	1 3/16	3/8	3/32	5/16	9/16	3/16	1/8	1 1/16	1/16
5/16	9/16	15/16	1 3/16	3/8	3/32	5/16	9/16	3/16	1/8	1 1/16	1/16
3/8	1 1/16	1 1/8	1 1/2	7/16	1/8	7/16	1 1/16	7/32	3/16	7/8	3/32
7/16	1 1/16	1 1/8	1 1/2	7/16	1/8	7/16	1 1/16	7/32	3/16	7/8	3/32
1/2	2 7/32	1 5/16	1 3/4	1/2	5/32	9/16	1 5/16	1/4	7/32	1 1/16	1/8
9/16	2 7/32	1 5/16	1 3/4	1/2	5/32	9/16	1 5/16	1/4	7/32	1 1/16	1/8
5/8	1	1 1/16	2 1/4	9/16	3/16	1 1/16	1 1/8	9/32	1/4	1 1/4	1/8
1 1/16	1	1 1/16	2 1/4	9/16	3/16	1 1/16	1 1/8	9/32	1/4	1 1/4	1/8
3/4	1	1 1/16	2 1/4	9/16	3/16	1 1/16	1 1/8	9/32	1/4	1 1/4	1/8

### WING NUTS

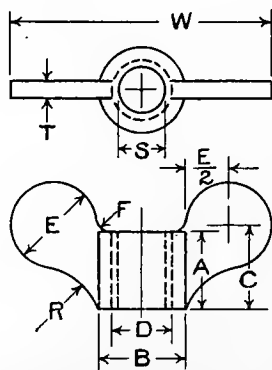

D	S	A	B	C	E	F	R	T	W	THD.
1/8	#40	5/32	7/32	7/32	7/32	1/16	1/4	3/32	2 1/32	40
3/16	#24	1/4	5/16	5/16	5/16	1/16	9/32	3/32	1 5/16	32
1/4	13/64	1/32	13/32	13/32	13/32	3/32	5/16	1/8	1 7/32	20
5/16	1/4	7/16	1/2	1/2	1/2	3/32	3/8	1/8	1 1/2	18
3/8	19/64	1/2	9/16	1/32	9/16	3/32	7/16	1/8	1 1/16	16
7/16	23/64	9/16	2 1/32	9/16	2 1/32	1/8	7/16	5/32	1 3/32	14
1/2	13/32	5/8	3/4	5/8	3/4	1/8	7/16	5/32	2 1/4	13
9/16	15/32	1 1/16	2 1/32	1 1/16	2 1/32	5/32	1/2	3/16	2 17/32	12
5/8	33/64	3/4	1 5/16	3/4	1 5/16	5/32	1/2	3/16	2 13/16	11



# MACHINE HAND WHEELS

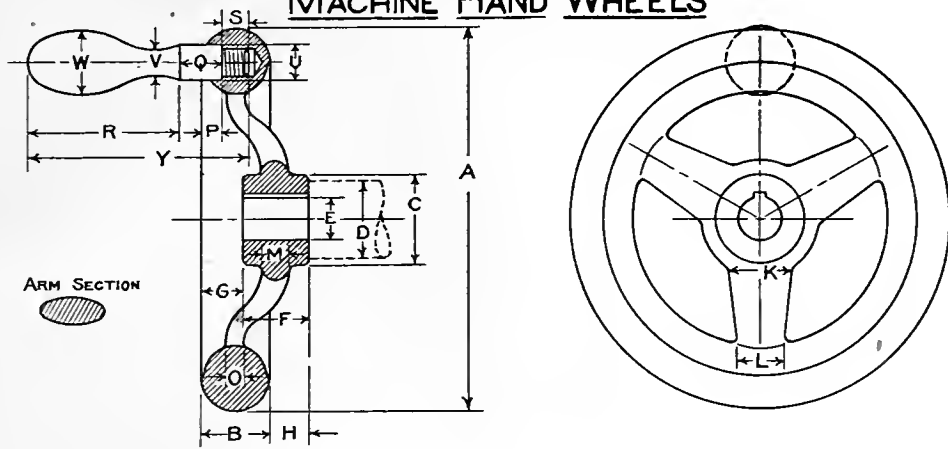

PRATT & WHITNEY CO.

A	B	C	D	E	F	G	H	K	L	M	O	ARMS	SPLINE	HAND	P	Q	R	S	TAP	U	V	W	Y	
3	$\frac{5}{8}$	$\frac{11}{16}$	$\frac{5}{8}$	$\frac{3}{8}$	$\frac{9}{16}$	$\frac{5}{16}$	$\frac{1}{4}$	$\frac{15}{32}$	$\frac{13}{32}$	$\frac{1}{4}$	$\frac{3}{16}$	3	$\frac{1}{16} \times \frac{1}{32}$	00	$\frac{3}{16}$	$\frac{1}{4}$	$\frac{5}{16}$	$\frac{3}{8}$	$\frac{5}{16} - 28$	$\frac{3}{8}$	$\frac{1}{4}$	$\frac{17}{32}$	$\frac{15}{16}$	
4	$\frac{11}{16}$	$\frac{13}{16}$	$\frac{3}{4}$	$\frac{3}{8}$	$\frac{5}{8}$	$\frac{15}{32}$	$\frac{13}{32}$	$\frac{5}{8}$	$\frac{11}{32}$	$\frac{7}{32}$	"	"	$\frac{1}{16} \times \frac{1}{32}$	0	$\frac{1}{4}$	$\frac{3}{8}$	$\frac{15}{16}$	$\frac{3}{8}$	"	"	$\frac{15}{32}$	$\frac{11}{32}$	$\frac{13}{16}$	$\frac{21}{16}$
4 $\frac{1}{2}$	$\frac{7}{8}$	$\frac{1}{8}$	1	$\frac{7}{16}$	$\frac{3}{4}$	$\frac{1}{2}$	$\frac{3}{8}$	$\frac{3}{4}$	$\frac{1}{2}$	$\frac{11}{32}$	$\frac{1}{4}$	"	$\frac{3}{32} \times \frac{3}{64}$	1	$\frac{1}{4}$	$\frac{9}{16}$	2	$\frac{3}{8}$	$\frac{3}{8} - 24$	$\frac{15}{32}$	$\frac{13}{32}$	$\frac{15}{16}$	$\frac{21}{16}$	
5	$\frac{7}{8}$	$\frac{13}{16}$	$\frac{1}{16}$	$\frac{9}{16}$	$\frac{7}{8}$	$\frac{15}{32}$	$\frac{15}{32}$	$\frac{7}{8}$	$\frac{5}{8}$	$\frac{3}{8}$	$\frac{1}{4}$	"	$\frac{3}{32} \times \frac{3}{64}$	1	$\frac{1}{4}$	$\frac{9}{16}$	2	$\frac{3}{8}$	"	"	$\frac{15}{32}$	$\frac{13}{32}$	$\frac{15}{16}$	$\frac{21}{16}$
6	1	$\frac{1}{4}$	$\frac{1}{8}$	$\frac{9}{16}$	1	$\frac{5}{8}$	$\frac{5}{8}$	$\frac{15}{16}$	$\frac{11}{16}$	$\frac{1}{2}$	$\frac{11}{32}$	"	$\frac{1}{8} \times \frac{1}{16}$	2	$\frac{5}{16}$	$\frac{9}{16}$	$2\frac{3}{8}$	$\frac{1}{2}$	"	"	$\frac{1}{2}$	$\frac{7}{16}$	1	$3\frac{7}{16}$
7	1	$\frac{1}{2}$	$\frac{3}{8}$	$\frac{11}{16}$	1	$\frac{13}{16}$	$\frac{13}{16}$	$\frac{5}{8}$	$\frac{1}{2}$	$\frac{3}{8}$	"	"	$\frac{1}{8} \times \frac{1}{16}$	3	$\frac{5}{16}$	$\frac{5}{8}$	$2\frac{13}{16}$	$\frac{1}{2}$	"	"	$\frac{19}{32}$	$\frac{15}{32}$	$\frac{1}{8}$	$3\frac{15}{16}$
8	$\frac{1}{8}$	$\frac{13}{16}$	$\frac{5}{8}$	1	1	$\frac{7}{8}$	$\frac{3}{4}$	1	$\frac{5}{8}$	$\frac{9}{16}$	$\frac{3}{8}$	"	$\frac{1}{8} \times \frac{1}{16}$	4	$\frac{3}{8}$	$\frac{5}{8}$	$3\frac{1}{8}$	$\frac{1}{2}$	"	"	$\frac{19}{32}$	$\frac{1}{2}$	$\frac{1}{4}$	$4\frac{1}{4}$
9	$\frac{1}{8}$	$\frac{7}{8}$	$\frac{3}{4}$	1	1	1	$\frac{7}{8}$	$\frac{1}{8}$	$\frac{3}{4}$	$\frac{9}{16}$	$\frac{3}{8}$	"	$\frac{1}{8} \times \frac{1}{16}$	4	$\frac{3}{8}$	$\frac{5}{8}$	$3\frac{1}{8}$	$\frac{1}{2}$	"	"	$\frac{19}{32}$	$\frac{1}{2}$	$\frac{1}{4}$	$4\frac{1}{4}$
10	$\frac{1}{4}$	$\frac{15}{16}$	$\frac{11}{16}$	$\frac{7}{8}$	1	$\frac{1}{4}$	1	$\frac{13}{16}$	$\frac{7}{8}$	$\frac{5}{8}$	$\frac{7}{16}$	"	$\frac{3}{16} \times \frac{3}{32}$	5	$\frac{7}{16}$	$\frac{13}{16}$	$3\frac{7}{16}$	$\frac{1}{2}$	$\frac{7}{16} - 20$	$\frac{21}{32}$	$\frac{9}{16}$	$\frac{15}{16}$	$4\frac{3}{4}$	
11	$\frac{1}{4}$	$\frac{15}{16}$	$\frac{11}{16}$	$\frac{7}{8}$	1	$\frac{5}{16}$	$\frac{1}{16}$	$\frac{13}{8}$	1	$\frac{5}{8}$	$\frac{7}{16}$	"	$\frac{3}{16} \times \frac{3}{32}$	5	$\frac{7}{16}$	$\frac{13}{16}$	$3\frac{7}{16}$	$\frac{1}{2}$	"	"	$\frac{21}{32}$	$\frac{9}{16}$	$\frac{15}{16}$	$4\frac{3}{4}$
12	$\frac{7}{16}$	2	$\frac{7}{8}$	$\frac{7}{8}$	$\frac{1}{4}$	$\frac{3}{16}$	1	$\frac{7}{16}$	$\frac{1}{16}$	$\frac{11}{16}$	$\frac{9}{16}$	"	$\frac{3}{16} \times \frac{3}{32}$	6	$\frac{7}{16}$	$\frac{7}{8}$	$3\frac{5}{8}$	$\frac{11}{16}$	$\frac{1}{2} - 16$	$\frac{3}{4}$	$\frac{5}{8}$	$\frac{7}{16}$	$5\frac{3}{16}$	

### BALL CRANK HANDLES

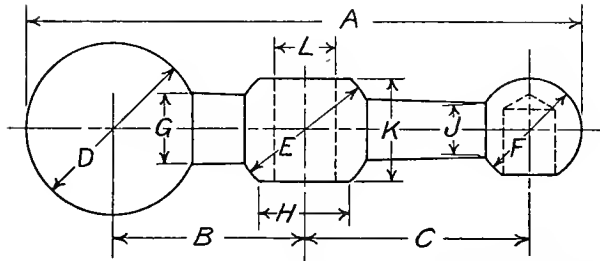

M is No. of Mach. Handle.

No.	A	B	C	D	E	F	G	H	J	K	L	M
1	3 1/8	1 3/32	1/4	15/16	25/32	5/8	7/16	1/2	5/16	9/16	5/16	1
2	3 1/2	1 7/32	1 3/8	1 1/16	29/32	3/4	15/32	9/16	11/32	1 1/16	3/8	1
3	4	1 3/8	1 5/8	1 1/4	1 1/32	3/4	17/32	1 1/16	13/32	3/4	7/16	2
4	4 1/2	1 13/32	1 13/16	1 5/16	1 1/8	7/8	19/32	3/4	7/16	13/16	1/2	2
5	5	1 3/4	2 1/32	1 1/2	1 1/4	15/16	1 1/16	13/16	1/2	7/8	1/2	3
6	5 1/2	2	2 1/4	1 1/2	1 5/16	1	3/4	7/8	1/2	15/16	1/2	3
7	6	2 3/8	2 1/2	1 5/8	1 3/8	1	3/4	15/16	1/2	31/32	5/8	3
8	6 1/2	2 7/16	2 3/4	1 5/8	1 1/16	1	3/4	15/16	1/2	1 1/16	5/8	4
9	7	2 5/8	3	1 3/4	1 7/16	1	3/4	15/16	9/16	1 1/16	5/8	4
10	7 1/2	2 7/8	3 1/4	1 3/4	1 1/2	1	3/4	15/16	9/16	1 1/8	5/8	5
11	8	3 1/8	3 15/32	1 3/4	1 1/2	1 1/16	3/4	15/16	9/16	1 1/8	5/8	5
12	8 1/2	3 3/8	3 1/16	1 3/4	1 9/16	1 1/8	3/4	1	5/8	1 1/8	3/4	6
13	9	3 5/8	3 29/32	1 3/4	1 5/8	1 1/16	3/4	1 1/16	5/8	1 3/16	3/4	6

### MACHINE HANDLES

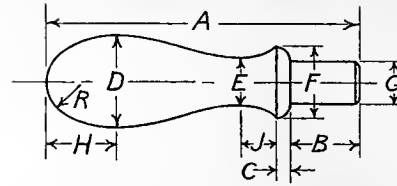

No.	A	B	C	D	E	F	G	H	J	R
1	2 1/4	1/2	3/32	1 1/16	1 1/32	1/2	5/16	1/2	1/4	1/4
2	2 3/4	5/8	1/8	1 1/16	1 1/32	5/8	3/8	9/16	5/16	5/16
3	3 1/8	3/4	1/8	1	1/2	5/8	3/8	5/8	3/8	3/8
4	3 1/2	3/4	5/32	1 1/16	1 1/32	3/4	7/16	1 1/16	7/16	13/32
5	4	7/8	3/16	1 1/8	9/16	23/32	7/16	3/4	1/2	7/16
6	4 3/8	7/8	7/32	1 1/16	1 1/32	15/16	1 1/32	13/16	9/16	7/16

### BALL LEVER HANDLES

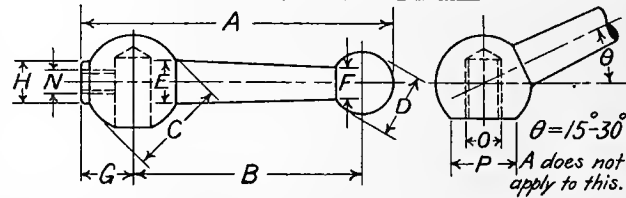

No.	A	B	C	D	E	F	G	H	N	O	P
1	4 1/2	3 3/8	1 3/8	7/8	5/8	7/16	3/4	5/8	5/16	1/2	1
2	5 1/2	4 3/16	1 1/2	1	1 1/16	1/2	13/16	5/8	3/8	1/2	1 1/8
3	6 1/2	5	1 3/4	1	3/4	9/16	1	5/8	3/8	1/2	1 1/4
4	7 1/2	6	1 3/4	1	3/4	9/16	1	1/16	1/16	5/8	1 3/8
5	8 1/2	6 7/8	1 3/4	1 1/8	3/4	5/8	1 1/16	1 1/16	7/16	5/8	1 3/8
6	9	7 1/32	1 3/4	1 1/16	1 1/16	5/8	1 1/16	1 1/16	7/16	5/8	1 3/8

### STANDARD WASHERS

Diameter of Bolt	Diameter of Hole	Outside Diam.	Thickness B.W.G.	Nearest Fraction	Approx. Number in 10 Pounds
3/16	1/4	9/16	18	3/64	3700
1/4	5/16	3/4	16	1/16	1390
5/16	3/8	7/8	16	1/16	1120
3/8	7/16	1	14	3/64	680
7/16	1/2	1 1/4	14	3/64	430
1/2	9/16	1 3/8	12	1/64	270
9/16	5/8	1 1/2	12	1/64	230
5/8	1 1/16	1 3/4	10	3/64	130
3/4	1 1/8	2	10	3/64	100
7/8	1 1/16	2 1/4	9	5/32	75
1	1 1/16	2 1/2	9	5/32	62
1 1/8	1 1/4	2 3/4	9	5/32	52
1 1/4	1 3/8	3	9	5/32	40
1 3/8	1 1/2	3 1/4	8	1/64	32
1 1/2	1 5/8	3 1/2	8	1/64	28
1 5/8	1 3/4	3 3/4	8	1/64	24
1 3/4	1 7/8	4	8	1/64	22
1 7/8	2	4 1/4	8	1/64	19
2	2 1/8	4 1/2	8	1/64	17
2 1/4	2 3/8	4 3/4	6	1/64	13
2 1/2	2 5/8	5	5	1/32	11

### CAST WASHERS

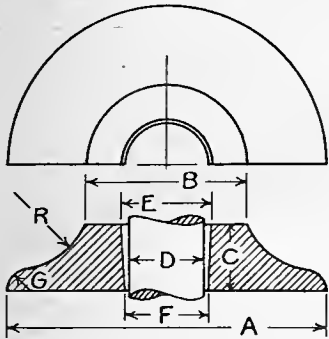

D	A	B	C	E	F	G	R
1/2	2 1/4	1/8	3/8	5/8	9/16	1/8	1/2
5/8	2 3/4	1/8	1/2	3/4	11/16	5/32	5/8
3/4	3 1/4	5/8	5/8	29/32	13/16	7/32	3/4
7/8	3 3/4	7/8	3/4	1/16	31/32	1/4	7/8
1	4 1/4	2 3/8	7/8	3/16	1/32	9/32	1
1 1/8	4 3/4	2 3/8	1	1/16	7/32	1/32	1 1/8
1 1/4	5 1/4	2 5/8	1 1/8	15/32	1/8	3/8	1 1/4
1 3/8	5 3/4	2 7/8	1 1/4	1/8	1/2	13/32	1 3/8
1 1/2	6 1/4	3 1/8	1 3/8	3/4	5/8	15/32	1 1/2
1 3/4	7 1/4	3 5/8	1 5/8	2	7/8	9/16	1 3/4
2	8 1/4	4 1/8	1 7/8	2 1/4	2 1/8	5/8	2

### SPRING COTTERS

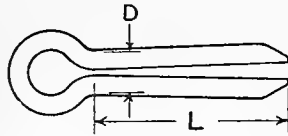

BWG	D	LENGTH - L
13	3/32	1/2" TO 2" BY 4THS
12	7/64	" " " " "
11	1/8	1/2" TO 2 1/2" " "
10	9/64	" " " " "
9	5/32	" " " " "
8	11/64	" " " " "
7	3/16	3/4" TO 3" " "
6	13/64	" " " " "
5	7/32	1" TO 3" " "
4	1/4	1" TO 4" " "
1	5/16	" " " " "
	3/8	1/2" TO 4" " "
	7/16	1 3/4" TO 4" " " ALSO 5" "
	1/2	2" TO 4" BY 4THS ALSO 5" - 6"
	5/8	3" TO 4" BY 4THS ALSO 5" - 6"

### T-SLOTS

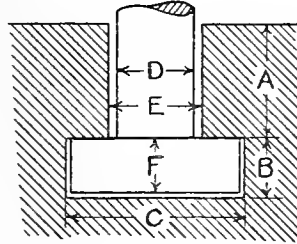
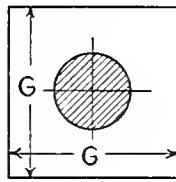

D	A	B	C	E	F	G
1/4	3/8	5/32	5/8	5/16	1/8	9/16
5/16	7/16	7/32	11/16	3/8	3/16	5/8
3/8	7/16	7/32	13/16	7/16	3/16	3/4
7/16	9/16	9/32	15/16	1/2	1/4	7/8
1/2	3/4	1/32	3/16	5/8	3/8	1/8
5/8	1	17/32	5/16	3/4	1/2	1/4
3/4	1 1/16	11/16	1/8	5/8	5/8	9/16
7/8	1 3/16	13/16	1/8	1	3/4	13/16

### EYE BOLTS

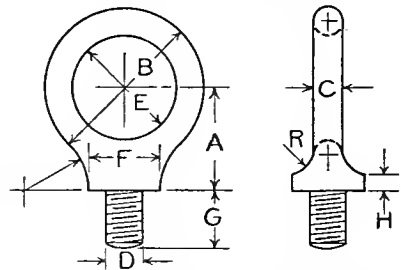

D	A	B	C	E	F	G	H	R
3/8	1 9/16	2 5/8	5/16	2	3/4	7/8	3 5/16	5/16
1/2	1 13/16	2 7/8	3/8	2 1/8	1	1	1 1/4	7/16
5/8	2 1/16	3 1/4	1/2	2 1/4	1 1/4	1 1/8	5 5/16	1/2
3/4	2 3/16	3 1/2	9/16	2 3/8	1 7/16	1 1/4	5 5/16	5/8
7/8	2 3/8	3 3/4	5/8	2 1/2	1 11/16	1 3/8	3 3/8	11/16
1	2 11/16	4 1/4	3/4	2 3/4	1 7/8	1 1/2	7 7/16	3/4
1 1/8	2 15/16	4 1/2	13/16	2 7/8	2 1/8	1 5/8	1 1/2	7/8
1 1/4	3 1/8	4 3/4	7/8	3	2 3/8	1 3/4	1 1/2	1
1 3/8	3 5/16	5 1/8	1	3 1/8	2 5/8	1 7/8	9 9/16	1 1/16
1 1/2	3 1/2	5 3/8	1 1/16	3 1/4	2 3/4	2	5 5/8	1 1/8
1 5/8	3 3/4	5 5/8	1 1/8	3 3/8	3	2 1/8	11 1/16	1 1/4
1 3/4	4	6	1 1/4	3 1/2	3 1/4	2 1/4	3 3/4	5 1/16
1 7/8	4 1/4	6 1/4	1 5/16	3 5/8	3 1/2	2 3/8	13 1/16	1 7/16
2	4 1/2	6 1/2	1 3/8	3 3/4	3 3/4	2 1/2	7 7/8	9 1/16

### Properties of Standard Wrought Iron Pipe

Nominal Size	External Diameter	Internal Diameter	Thickness	Length per Sq. Ft. of External Surface	Internal Area	Area of Metal	Moment of Inertia	Section Modulus	Square of Radius of Gyration	Nominal Weight per Foot	Threads per Inch
1	.405	.27	.068	9.44	.0568	.0720	.001	.005	.015	.241	27
1 1/2	.54	.364	.088	7.07	.1041	.1249	.003	.012	.027	.42	18
2	.675	.493	.091	5.66	.1909	.1669	.007	.022	.044	.559	18
2 1/2	.84	.622	.109	4.55	.3039	.2503	.017	.041	.068	.837	14
3	1.05	.824	.113	3.64	.5333	.3326	.037	.071	.111	1.115	14
3 1/2	1.315	1.047	.134	2.90	.8609	.4972	.088	.133	.176	1.668	11 1/2
4	1.66	1.38	.14	2.30	1.4957	.6685	.195	.235	.291	2.244	11 1/2
4 1/2	2.375	2.067	.154	1.61	3.3556	1.074	.666	.561	.388	3.609	11 1/2
5	2.875	2.467	.204	1.33	4.7800	1.712	1.53	1.07	.898	5.739	8
5 1/2	3.5	3.066	.217	1.09	7.3827	2.238	3.02	1.73	1.35	7.536	8
6	4.0	3.548	.226	.955	9.886	2.680	4.79	2.39	1.79	9.001	8
6 1/2	4.5	4.026	.237	.849	12.730	3.174	7.23	3.21	2.28	10.665	8
7	5.563	4.508	.246	.764	15.960	3.675	10.41	4.16	2.83	12.34	8
7 1/2	6.625	5.045	.259	.687	19.985	4.321	15.2	5.47	3.52	14.502	8
8	7.625	7.023	.301	.501	38.743	6.921	46.5	12.2	6.72	23.271	8
8 1/2	8.625	7.981	.322	.443	50.021	8.405	72.4	16.8	8.64	28.177	8
9	9.625	8.937	.344	.397	62.722	10.04	108	22.5	10.8	33.701	8
10	10.75	10.018	.366	.355	78.822	11.94	161	30.0	13.5	40.065	8
11	11.75	11.00	.375	.325	95.034	13.40	232	38.6	16.9	45.95	8
12	12.75	12.00	.375	.299	113.09	14.59	279	43.8	19.2	48.985	8

### Properties of Extra Strong Pipe

1	.405	.205	.10	9.44	.033	.096	.001	.006	.013	.29	27
1 1/2	.54	.294	.123	7.07	.068	.161	.004	.014	.024	.54	18
2	.675	.421	.127	5.66	.139	.219	.009	.026	.040	.74	18
2 1/2	.84	.542	.149	4.55	.231	.323	.020	.048	.062	1.09	14
3	1.05	.736	.157	3.64	.425	.441	.045	.086	.103	1.39	14
3 1/2	1.315	.951	.182	2.90	.710	.648	.107	.162	.165	2.17	11 1/2
4	1.66	1.272	.194	2.30	1.271	.893	.244	.294	.273	3.00	11 1/2
4 1/2	1.9	1.494	.203	2.01	1.753	1.082	.395	.416	.365	3.63	11 1/2
5	2.375	1.933	.221	1.61	2.935	1.495	.877	.738	.586	5.02	11 1/2
5 1/2	2.875	2.315	.28	1.33	4.209	2.283	1.94	1.35	.852	7.67	8
6	3.5	2.892	.304	1.09	6.569	3.052	3.93	2.25	1.29	10.25	8
6 1/2	4.0	3.358	.321	.955	8.856	3.710	6.33	3.16	1.70	12.47	8
7	4.5	3.818	.341	.849	11.449	4.455	9.72	4.32	2.18	14.97	8
7 1/2	5.0	4.28	.360	.764	14.387	5.248	14.20	5.67	2.70	18.22	8
8	5.563	4.813	.375	.687	18.193	6.113	20.7	7.43	3.38	20.54	8
8 1/2	6.625	5.751	.437	.577	25.976	8.496	40.9	12.4	4.81	28.58	8
9	7.625	6.625	.50	.501	34.472	11.192	71.4	18.7	6.38	37.67	8
9 1/2	8.625	7.625	.50	.443	45.664	12.762	105.8	24.55	8.29	43.00	8
10	9.625	8.625	.50	.397	58.426	14.334	150.0	31.2	10.45	48.25	8
11	10.75	9.75	.50	.355	74.662	16.101	212.0	39.45	13.17	54.25	8
12	12.75	11.75	.50	.299	108.43	19.25	361.0	56.7	18.76	65.00	8

### Properties of Double Extra Strong Pipe

1 1/2	.84	.444	.298	4.55	.047	.507	.024	.058	.048	1.7	14
2	1.05	.527	.314	3.64	.140	.726	.058	.111	.080	2.44	14
2 1/2	1.315	.687	.364	2.90	.271	1.087	.141	.214	.130	3.65	11 1/2
3	1.66	.885	.388	2.30	.615	1.549	.343	.413	.221	5.2	11 1/2
3 1/2	1.90	1.088	.406	2.01	.930	1.905	.571	.601	.300	6.4	11 1/2
4	2.375	1.491	.442	1.61	1.744	2.686	1.32	1.11	.491	9.02	11 1/2
4 1/2	2.875	1.755	.56	1.33	2.419	4.073	2.89	2.01	.709	13.68	8
5	3.50	2.284	.608	1.09	4.097	5.524	6.03	3.45	1.09	18.56	8
5 1/2	4.0	2.716	.642	.955	5.794	6.772	9.90	4.95	1.46	22.75	8
6	4.5	3.136	.682	.849	7.724	8.180	15.40	6.84	1.88	27.48	8
6 1/2	5.0	3.564	.718	.764	9.976	9.659	22.75	9.11	2.36	32.53	8
7	5.563	4.063	.750	.687	12.965	11.341	33.6	12.1	2.96	38.12	8
7 1/2	6.625	4.875	.875	.577	18.665	15.807	66.9	20.2	4.23	53.11	8
8	7.625	5.875	.875	.501	27.109	18.555	107.3	28.2	5.79	62.38	8
8 1/2	8.625	6.875	.875	.443	37.122	21.304	162.0	37.6	7.61	71.62	8

# FITTINGS FOR PIPE RAILINGS

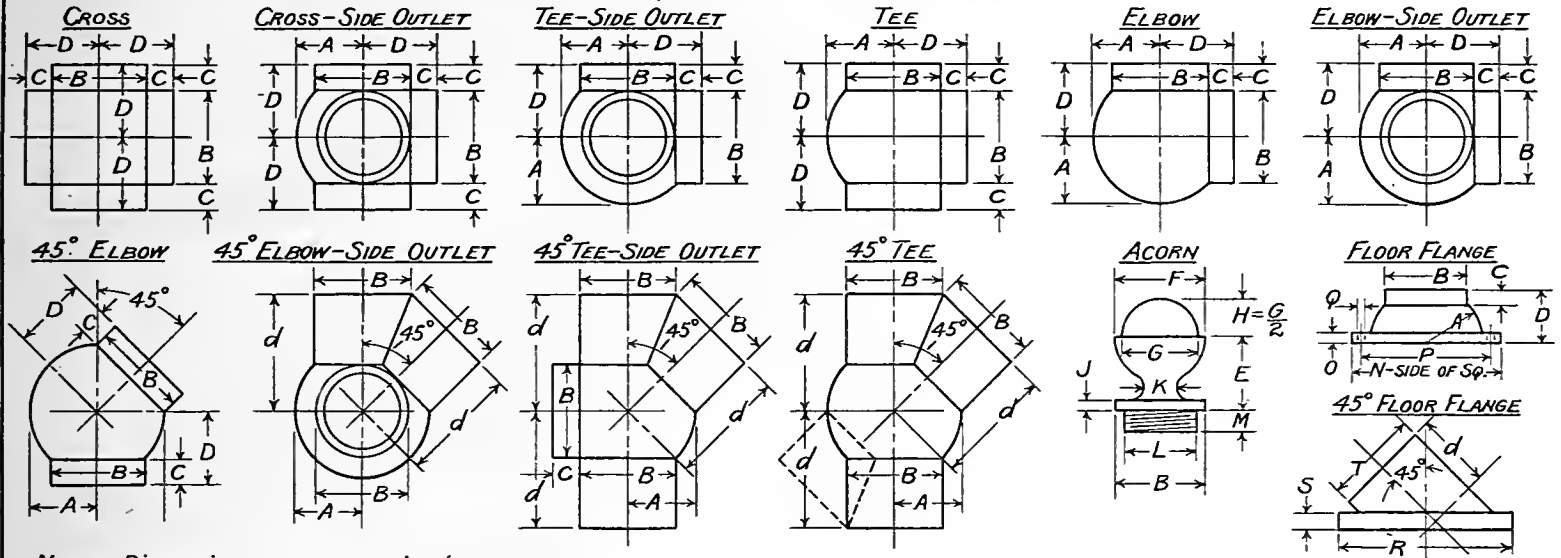

NOTE - Dimensions are approximate.

PIPE	A	B	C	D	d	E	F	G	J	K	L	M	N	O	P	Q Wood SCREW	R	S	T				
1/2																							
3/4	31/32	1/8	5/8	15/16	21/32	1/8	1/2	15/16	1/8	7/8	1/16	1/2	2 3/4	1/4	2	No. 9							
1	15/32	1/8	5/8	17/16	7/32	3/16	11/16	1/2	1/8	15/16	1/16	1/2	3	3/8	2 1/4	" "							
1 1/4	13/32	2	11/16	11/16	2 13/32	1 3/8	1 7/8	11/16	3/16	1/16	1 21/32	1/2	3 1/2	3/8	2 3/4	" 14	4 3/8	1/2	2 7/16				
1 1/2	19/32	2 1/4	3/4	7/8	2 23/32	1 5/8	2 3/16	1 15/16	1/4	3/16	1 29/32	5/8	4	3/8	3 1/8	" "							
2	1 61/64	2 3/4	13/16	2 3/16	3 5/16	2 1/8	2 5/8	2 1/4	5/16	1 1/2	2 3/8	11/16	5	3/8	4	" 19							

# STANDARD TAPERS

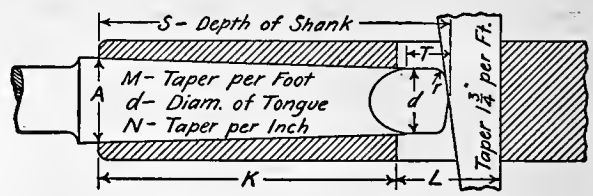
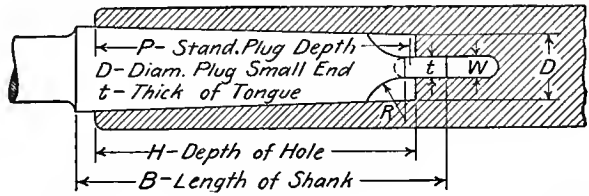

No.	D	A	P	B	H	K	L	W	T	d	t	R	r	S	M	N
<b>BROWN &amp; SHARPE STAND.</b>																
1	.20	.2390	$1\frac{5}{16}$	$1\frac{1}{4}$	$1\frac{1}{16}$	$1\frac{5}{8}$	$\frac{3}{8}$	.135	$1\frac{3}{16}$	.170	$\frac{1}{8}$	$\frac{3}{16}$	.030	$1\frac{3}{16}$	.500	.0416
2	.25	.2994	$1\frac{3}{8}$	$1\frac{9}{16}$	$1\frac{5}{16}$	$1\frac{11}{4}$	$\frac{1}{2}$	.166	$1\frac{1}{4}$	.220	$\frac{5}{32}$	$\frac{3}{8}$	.030	$1\frac{1}{2}$	.500	.0416
3	.312	.3953	2	$2\frac{1}{16}$	$2\frac{3}{8}$	$1\frac{3}{32}$	$\frac{5}{8}$	.197	$1\frac{5}{16}$	.282	$\frac{3}{16}$	$\frac{3}{8}$	.040	$2\frac{3}{8}$	.500	.0416
4	.35	.4020	$1\frac{1}{4}$	$1\frac{3}{4}$	$1\frac{3}{8}$	$1\frac{11}{16}$	$1\frac{1}{6}$	.228	$1\frac{3}{8}$	.320	$\frac{3}{16}$	$\frac{5}{16}$	.050	$1\frac{3}{8}$	.500	.0416
5	.45	.5229	$1\frac{3}{4}$	$2\frac{3}{32}$	$1\frac{1}{4}$	$1\frac{11}{16}$	$\frac{3}{4}$	.260	$1\frac{3}{8}$	.420	$\frac{1}{4}$	$\frac{5}{16}$	.060	$2\frac{3}{16}$	.500	.0416
6	.50	.5989	$2\frac{3}{8}$	$2\frac{33}{32}$	$2\frac{1}{8}$	$2\frac{19}{32}$	$\frac{7}{8}$	.291	$1\frac{7}{16}$	.460	$\frac{3}{8}$	$\frac{5}{16}$	.060	$2\frac{1}{8}$	.500	.0416
7	.60	.7250	3	$3\frac{3}{8}$	$3\frac{1}{8}$	$2\frac{33}{32}$	$1\frac{5}{16}$	.322	$1\frac{5}{8}$	.560	$\frac{3}{8}$	$\frac{3}{8}$	.070	$3\frac{1}{8}$	.500	.0416
8	.75	.8984	$3\frac{9}{16}$	$4\frac{1}{4}$	$3\frac{1}{16}$	$3\frac{29}{32}$	1	.353	$1\frac{1}{2}$	.710	$\frac{1}{2}$	$\frac{3}{8}$	.080	$4\frac{1}{2}$	.500	.0416
9	.90	1.0667	4	$4\frac{3}{4}$	$4\frac{1}{8}$	$3\frac{1}{2}$	$1\frac{1}{8}$	.385	$1\frac{9}{16}$	.860	$\frac{5}{8}$	$\frac{7}{16}$	.100	$4\frac{3}{8}$	.500	.0416
9	.90	1.0770	$4\frac{1}{4}$	5	$4\frac{3}{8}$	4	$1\frac{1}{8}$	.385	$1\frac{9}{16}$	.860	$\frac{5}{8}$	$\frac{7}{16}$	.100	$4\frac{3}{8}$	.500	.0416
10	1.0446	1.2596	5	$6\frac{1}{16}$	$5\frac{1}{8}$	$4\frac{33}{32}$	$1\frac{5}{16}$	.447	$1\frac{5}{8}$	1.010	$\frac{7}{16}$	$\frac{7}{16}$	.110	$5\frac{3}{32}$	.5161	.043
10	1.0446	1.2888	$5\frac{1}{16}$	$6\frac{3}{4}$	$5\frac{1}{16}$	$5\frac{17}{32}$	$1\frac{5}{16}$	.447	$1\frac{5}{8}$	1.010	$\frac{7}{16}$	$\frac{7}{16}$	.110	$6\frac{3}{32}$	.5161	.043
11	1.25	1.5312	$6\frac{3}{4}$	$7\frac{1}{16}$	$6\frac{3}{8}$	$6\frac{19}{32}$	$1\frac{5}{16}$	.447	$1\frac{5}{8}$	1.210	$\frac{7}{16}$	$\frac{1}{2}$	.130	$7\frac{1}{32}$	.500	.0416
12	1.50	1.7968	$7\frac{1}{8}$	$8\frac{9}{32}$	$7\frac{1}{4}$	$6\frac{15}{16}$	$1\frac{1}{2}$	.510	$1\frac{3}{4}$	1.460	$\frac{1}{2}$	$\frac{1}{2}$	.150	$7\frac{1}{16}$	.500	.0416
13	1.75	2.0729	$7\frac{3}{4}$	$8\frac{23}{32}$	$7\frac{3}{8}$	$7\frac{9}{16}$	$1\frac{1}{2}$	.510	$1\frac{3}{4}$	1.710	$\frac{1}{2}$	$\frac{5}{8}$	.170	$8\frac{9}{16}$	.500	.0416
14	2.	2.3438	$8\frac{1}{2}$	9	$8\frac{3}{8}$	$8\frac{1}{32}$	$1\frac{1}{16}$	.572	$1\frac{5}{8}$	1.960	$\frac{9}{16}$	$\frac{3}{4}$	.190	$9\frac{5}{32}$	.500	.0416
15	2.25	2.6146	$8\frac{3}{4}$	10	$8\frac{1}{4}$	$8\frac{3}{32}$	$1\frac{1}{16}$	.572	$1\frac{5}{8}$	2.210	$\frac{9}{16}$	$\frac{7}{8}$	.210	$9\frac{3}{32}$	.500	.0416
16	2.50	2.8854	$9\frac{1}{4}$	$10\frac{1}{2}$	$9\frac{3}{8}$	9	$1\frac{1}{8}$	.635	$1\frac{7}{8}$	2.450	$\frac{5}{8}$	1	.230	$10\frac{1}{4}$	.500	.0416
<b>MORSE STAND.</b>																
0	.252	.356	2	$2\frac{11}{32}$	$2\frac{1}{32}$	$1\frac{5}{16}$	$\frac{9}{16}$	.160	$\frac{1}{4}$	.24	$\frac{5}{32}$	$\frac{5}{32}$	.04	$2\frac{7}{32}$	.625	.05208
1	.369	.475	$2\frac{1}{3}$	$2\frac{9}{16}$	$2\frac{1}{16}$	$2\frac{1}{16}$	$\frac{3}{4}$	.213	$\frac{5}{16}$	.35	$\frac{3}{8}$	$\frac{1}{16}$	.05	$2\frac{3}{8}$	.600	.05
2	.572	.7	$2\frac{9}{16}$	$3\frac{1}{16}$	$2\frac{5}{8}$	$2\frac{1}{2}$	$\frac{7}{8}$	.26	$\frac{3}{8}$	.26	$\frac{17}{32}$	$\frac{1}{4}$	.06	$2\frac{7}{8}$	.602	.05016
3	.778	.938	$3\frac{3}{16}$	$3\frac{3}{4}$	$3\frac{1}{4}$	$3\frac{1}{16}$	$1\frac{1}{16}$	.322	$\frac{7}{16}$	.322	$\frac{3}{4}$	$\frac{1}{4}$	.08	$3\frac{9}{16}$	.602	.05016
4	1.02	1.231	$4\frac{1}{16}$	$4\frac{1}{8}$	$4\frac{1}{8}$	$3\frac{3}{8}$	$1\frac{1}{4}$	.478	$1\frac{1}{2}$	.478	$\frac{3}{2}$	$\frac{1}{2}$	.10	4	.623	.05191
5	1.475	1.748	$5\frac{3}{16}$	6	$5\frac{1}{4}$	$4\frac{5}{16}$	$1\frac{1}{2}$	.635	$\frac{5}{8}$	.635	$1\frac{1}{32}$	$\frac{3}{8}$	.12	$5\frac{1}{4}$	.630	.0525
6	2.116	2.494	$7\frac{1}{4}$	8	$7\frac{3}{8}$	7	$1\frac{3}{4}$	.76	$1\frac{3}{4}$	.76	2	$\frac{1}{2}$	.15	8	.626	.05216
7	2.75	3.27	10	$11\frac{5}{8}$	$10\frac{1}{8}$	$9\frac{1}{2}$	$2\frac{5}{8}$	1.135	$1\frac{3}{2}$	$2\frac{11}{16}$	$1\frac{1}{2}$	$\frac{3}{4}$	.18	$11\frac{1}{4}$	.625	.05208

Table No. 13

# GAGE LINES — RIVET SPACING — RIVET DIMENSIONS

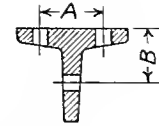
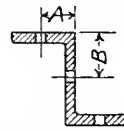
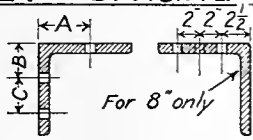
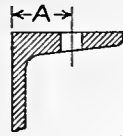
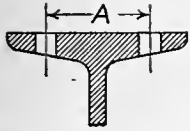

I BEAMS		Carnegie	
Depth	Weight	A	Max. Rivet
24	80-100	4	7/8
20	80-100	4	"
20	65-75	3 1/2	"
18	55-70	3 1/4	"
15	80-100	3 3/4	"
15	60-75	3 1/4	3/4
15	42-55	3	"
12	40-55	3	"
12	31 1/2-35	2 3/4	"
10	25-40	2 5/8	"
9	21-35	2 1/2	"
8	18-25 1/2	2 1/4	"
7	15-20	2 1/4	5/8
6	12 1/4-17 1/4	2	"
5	9 3/4-14 3/4	1 3/4	1/2
4	7 1/2-10 1/2	1 1/2	"
3	5 1/2-7 1/2	1 1/16	3/8

CHANNELS		Carnegie	
Depth	Weight	A	Max. Rivet
15	45-55	2 1/4	3/4
15	33-40	1 7/8	"
12	30-40	2	"
12	20 1/2-25	1 3/4	"
10	25-35	2	"
10	15-20	1 1/2	"
9	20-25	1 3/4	"
9	13 1/4-15	1 3/8	"
8	16 1/4-21 1/4	1 1/2	"
8	11 1/4-13 3/4	1 1/4	"
7	17 1/4-19 3/4	1 1/2	5/8
7	9 3/4-14 3/4	1 1/4	"
6	13-15 1/2	1 3/8	"
6	8-10 1/2	1 1/8	"
5	9-11 1/2	1 1/4	1/2
5	6 1/2	1	"
4	5 1/4-7 1/4	1	"
3	4-6	15/16	3/8

ANGLES		Amer. Br. Co.		
Leg	A	B	C	Max. Rivet
8	4 1/2	3	3	7/8
7	4	2 1/2	3	"
6	3 1/2	2 1/4	2 1/2	"
*6	3 1/2	2 1/2	2 1/4	"
5	3	2	1 3/4	"
4	2 1/4			"
3 1/2	2			"
3	1 3/4			"
2 3/4	1 5/8			3/4
2 1/2	1 5/8			5/8
2 1/4	1 1/4			"
2	1 1/8			1/2
1 3/4	1			"
1 1/2	7/8			3/8
1 1/4	3/4			"
1	9/16			1/4

\* For thick. over 3/4

Z-BARS		Amer. Br. Co.		
Nom. Web	Thick.	A	B	Max. Riv. A B
6	3/8-7/8	2 1/4	3	7/8 7/8
5	1 1/16-3/4	2 1/8	2 1/2	" "
5	5/16-5/8	2	2 1/2	" "
4	5/8-3/4	2	2	3/4 "
4	1/16-9/16	1 7/8	2	" "
4	1/4-3/8	1 3/4	2	" "
3	1/16-1/2	1 5/8	1 1/2	" 3/4
3	1/4-3/8	1 1/2	1 1/2	" "

T-BARS		Cambria			
FLANGE		STEM			
Wdt.	A	Max. Riv.	Depth	B	Max. Riv.
5	2 3/8	3/4	4	2 1/4	1
4 1/2	2 1/4	"	3 1/2	2	"
4	2	5/8	3	1 3/4	7/8
3 1/2	1 3/4	"	2 1/2	1 3/8	3/4
3	1 1/2	1/2	2 1/4	1 1/4	"
2 3/4	1 3/8	"	2	1 1/8	5/8
2 1/2	1 1/4	"	1 3/4	1	"
2 1/4	1 1/8	"	1 3/8	3/4	1/2
2	1	"	1 1/4	1 1/16	"
1 3/8	5/8	1/4	1 3/8	5/8	"
1 1/4	"	"	1 1/8	9/16	"
1 3/16	"	"	1 1/16	"	3/8
1 1/8	"	"	1	"	"
1	"	"	"	"	"

### MINIMUM CLEARANCES

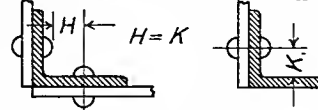

### MIN. RIVET SPACING

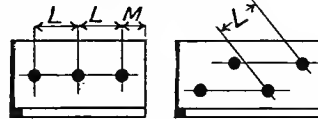

### RIVET DIMENSIONS

RIVET DIMENSIONS					CLEARANCE	SPACING		RIVET DIMENSIONS					CLEARANCE	SPACING	
Diam.	D	E	F	G	H = K	L	M	Diam.	D	E	F	G	H = K	L	M
3/8	1 1/16	5/16	5/8	3/16	5/8	1 1/4	7/8	3/4	1 1/4	9/16	1 3/16	3/8	7/8	2 1/4	1 1/4
1/2	7/8	3/8	3/4	1/4	1 1/16	1 5/8	1	7/8	1 7/16	5/8	1 3/8	7/16	1	2 5/8	1 1/2
5/8	1 1/16	7/16	1	5/16	1 3/16	1 7/8	1 1/8	1	1 5/8	1 1/16	1 9/16	1/2	1 1/16	3	1 5/8

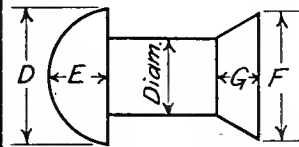

## JAW CLUTCH COUPLINGS - 1

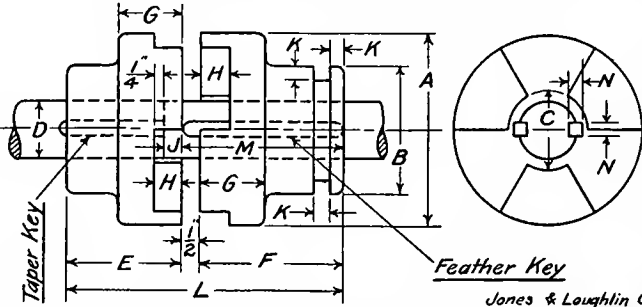

## JAW CLUTCH COUPLINGS - 2

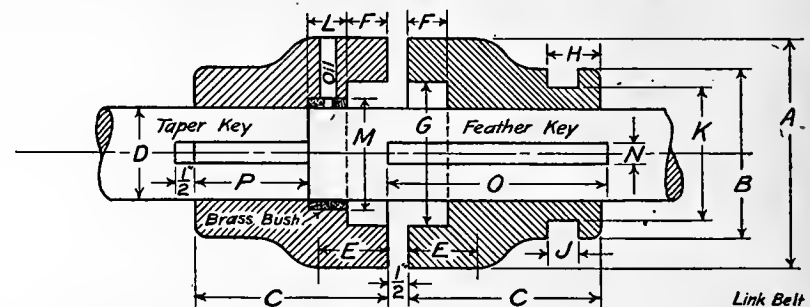

Jones & Loughlin Co.														Link Belt Co.														No. of Jaws Sq. Spir.			
D	A	B	C	E	F	G	H	J	K	L	M	N		D	A	B	C	E	F	G	H	J	K	L	M	N	O	P			
1/2	5	3 3/8	2	3	3 3/4	1 1/16	3/4	1/2	3/8	7/4	4 1/4	3/8		15/16	3	2 3/4	3 3/8	1 1/4	3/4	1 7/8	1	5/8	2		1/4	3 7/8	2 3/8		2	2	
1 1/4	5 3/4	3 15/16	2 3/8	3 1/2	4 3/8	2	7/8	5/8	7/16	8 3/8	4 7/8	7/16		1 3/16	3 1/2	2 3/4	3 7/16	1 3/8	13/16	2 1/4	1	5/8	2		5/16	4 1/4	2 5/8		"	"	
2	6 1/2	4 1/2	2 3/4	4	5	2 1/4	1	3/4	1/2	9 1/2	5 1/2	1 1/2		1 7/16	4	3 1/4	3 3/4	1 1/2	7/8	2 1/2	1 1/8	3/4	2 1/2		3/8	4 1/2	2 7/8		"	"	
2 1/4	7 1/4	5 1/16	3	4 1/2	5 5/8	2 9/16	1 1/8	7/8	9/16	10 5/8	6 1/8	9/16		1 11/16	4 1/2	3 1/4	4 3/16	1 5/8	15/16	2 3/4	1 1/8	3/4	2 1/2		7/16	5	3 1/4		"	"	
2 1/2	8	5 5/8	3 3/8	5	6 1/4	2 13/16	1 1/4	1	5/8	11 3/4	6 3/4	5/8		1 15/16	5	4	4 1/2	1 1/16	1	3 3/8	1 1/4	13/16	3		1/2	5 1/8	3 1/2		"	"	
2 3/4	8 3/4	6 3/16	3 3/4	5 1/2	6 7/8	3 3/8	1 3/8	1 1/8	1 1/16	12 7/8	7 3/8	1 1/16		2 1/16	5 1/2	4 1/2	4 3/4	1 3/4	1	3 1/2	1 3/8	1 13/16	3 1/2		9/16	5 1/2	3 3/4		"	4	
3	9 1/2	6 3/4	4	6	7 1/2	3 3/8	1 1/2	1 1/4	3/4	14	8	3/4		2 7/16	6	4 1/2	5 1/16	1 13/16	1 1/16	3 7/8	1 3/8	1 13/16	3 1/2	1	2 15/16	5 3/8	5 3/4	3		"	"
3 1/4	10 1/4	7 1/16	4 3/8	6 1/2	8 1/8	3 1 1/16	1 5/8	1 3/8	1 13/16	15 5/8	8 5/8	1 13/16		2 1 1/16	6 1/2	5 1/4	5 5/8	1 7/8	1 1/16	4 1/4	1 1/2	1 15/16	4	1 1/16	3 3/16	1 1/16	6 1/8	3 1/4		4	"
3 1/2	11	7 7/8	4 3/4	7	8 3/4	3 15/16	1 3/4	1 1/2	7/8	16 1/4	9 1/4	7/8		2 1 1/16	7	5 3/4	6	2	1 1/8	4 5/8	1 1/2	1 15/16	4 1/2	1 1/4	3 7/16	3 3/4	7	3 5/8		"	"
3 3/4	11 3/4	8 7/16	5	7 1/2	9 3/8	4 1/4	1 7/8	1 5/8	1 15/16	17 3/8	9 7/8	1 15/16		3 7/16	8	6 1/2	7 1/16	2 3/16	1 3/16	5 3/8	1 5/8	1 15/16	5 1/4	1 1/2	3 15/16	7 3/8	8	4 3/8		"	"
4	12 1/2	9	5 3/8	8	10	4 1/2	2	1 3/4	1	18 1/2	10 1/2	1		3 7/16	9	7	7 7/8	2 3/8	1 1/4	6 1/8	1 7/8	1 1/16	5 3/4	1 3/4	4 9/16	1	9	4 7/8		"	"
4 1/4	13 1/4	9 7/16	5 3/4	8 1/2	10 5/8	4 13/16	2 1/8	1 7/8	1 1/16	19 5/8	11 1/8	1 1/16		4 7/16	10	7 1/2	9 15/16	2 1/2	1 5/16	6 3/4	2	1 3/16	6 1/4	2	5 1/16	1 1/8	10 3/4	6 5/8		"	"
4 1/2	14	10 1/8	6	9	11 1/4	5 1/16	2 1/4	2	1 1/8	20 3/4	11 3/4	1 1/8		4 15/16	11	8 1/4	10 7/8	2 9/16	1 3/8	7 1/2	2 1/4	1 1/16	7	2 1/8	5 9/16	1 1/4	11 5/8	7 3/8		"	"
5	15 1/2	11 1/4	6 3/4	10	12 1/2	5 5/8	2 1/2	2 1/4	1 1/4	23	13	1 1/4		5 7/16	12	8 3/4	11 3/4	2 1 1/16	1 1/2	8 1/4	2 1/4	1 1/16	7 1/2	2 1/4	6 3/16	1 3/8	12 1/2	8		"	"
6	18 1/2	13 1/2	8	12	15	6 3/4	3	2 3/4	1 1/2	27 1/2	15 1/2	1 1/2		5 15/16	13	9 1/4	12 1/4	2 13/16	1 1/2	8 7/8	2 1/4	1 3/16	8	2 1/2	6 1 1/16	1 1/2	13	8 1/4		"	"

Table No. 15



# DIMENSIONS OF FLANGE COUPLINGS

*From the Amer. Mach.*

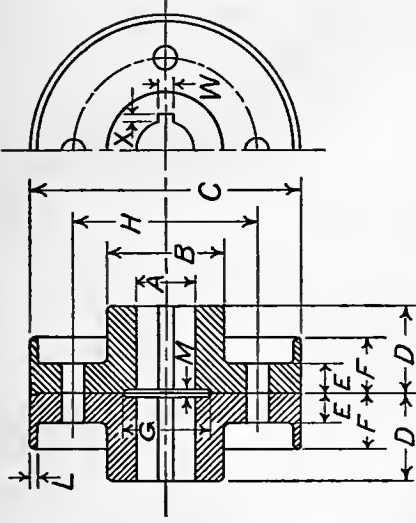
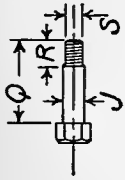

$T$  = Number of bolts.

Couplings are Press Fit  
on Shafts.

Taper of Keys  $\frac{3}{32}$ " to  $12$ ".

A	1	2	3	4	5	6	7	8	9	10	11	12	13	14	15	16	17	18	19	20	21	22	23	24	25	26	27	28	29	30	31	32	33	34	35	36	37	38	39	40	41	42	43	44	45	46	47	48	49	50	51	52	53	54	55	56	57	58	59	60	61	62	63	64	65	66	67	68	69	70	71	72	73	74	75	76	77	78	79	80	81	82	83	84	85	86	87	88	89	90	91	92	93	94	95	96	97	98	99	100																																																																																																																																																																																																																																																																																																										
B	2	2½	3	3½	4	4½	5	5½	6	6½	7	7½	8	8½	9	9½	10	10½	11	11½	12	12½	13	13½	14	14½	15	15½	16	16½	17	17½	18	18½	19	19½	20	20½	21	21½	22	22½	23	23½	24	24½	25	25½	26	26½	27	27½	28	28½	29	29½	30	30½	31	31½	32	32½	33	33½	34	34½	35	35½	36	36½	37	37½	38	38½	39	39½	40	40½	41	41½	42	42½	43	43½	44	44½	45	45½	46	46½	47	47½	48	48½	49	49½	50	50½	51	51½	52	52½	53	53½	54	54½	55	55½	56	56½	57	57½	58	58½	59	59½	60	60½	61	61½	62	62½	63	63½	64	64½	65	65½	66	66½	67	67½	68	68½	69	69½	70	70½	71	71½	72	72½	73	73½	74	74½	75	75½	76	76½	77	77½	78	78½	79	79½	80	80½	81	81½	82	82½	83	83½	84	84½	85	85½	86	86½	87	87½	88	88½	89	89½	90	90½	91	91½	92	92½	93	93½	94	94½	95	95½	96	96½	97	97½	98	98½	99	99½	100																																																																																																																																																																																																									
C	5½	6	7	7½	8	8½	9	9½	10	10½	11	11½	12	12½	13	13½	14	14½	15	15½	16	16½	17	17½	18	18½	19	19½	20	20½	21	21½	22	22½	23	23½	24	24½	25	25½	26	26½	27	27½	28	28½	29	29½	30	30½	31	31½	32	32½	33	33½	34	34½	35	35½	36	36½	37	37½	38	38½	39	39½	40	40½	41	41½	42	42½	43	43½	44	44½	45	45½	46	46½	47	47½	48	48½	49	49½	50	50½	51	51½	52	52½	53	53½	54	54½	55	55½	56	56½	57	57½	58	58½	59	59½	60	60½	61	61½	62	62½	63	63½	64	64½	65	65½	66	66½	67	67½	68	68½	69	69½	70	70½	71	71½	72	72½	73	73½	74	74½	75	75½	76	76½	77	77½	78	78½	79	79½	80	80½	81	81½	82	82½	83	83½	84	84½	85	85½	86	86½	87	87½	88	88½	89	89½	90	90½	91	91½	92	92½	93	93½	94	94½	95	95½	96	96½	97	97½	98	98½	99	99½	100																																																																																																																																																																																																																	
D	1½	1¾	2	2½	3	3½	4	4½	5	5½	6	6½	7	7½	8	8½	9	9½	10	10½	11	11½	12	12½	13	13½	14	14½	15	15½	16	16½	17	17½	18	18½	19	19½	20	20½	21	21½	22	22½	23	23½	24	24½	25	25½	26	26½	27	27½	28	28½	29	29½	30	30½	31	31½	32	32½	33	33½	34	34½	35	35½	36	36½	37	37½	38	38½	39	39½	40	40½	41	41½	42	42½	43	43½	44	44½	45	45½	46	46½	47	47½	48	48½	49	49½	50	50½	51	51½	52	52½	53	53½	54	54½	55	55½	56	56½	57	57½	58	58½	59	59½	60	60½	61	61½	62	62½	63	63½	64	64½	65	65½	66	66½	67	67½	68	68½	69	69½	70	70½	71	71½	72	72½	73	73½	74	74½	75	75½	76	76½	77	77½	78	78½	79	79½	80	80½	81	81½	82	82½	83	83½	84	84½	85	85½	86	86½	87	87½	88	88½	89	89½	90	90½	91	91½	92	92½	93	93½	94	94½	95	95½	96	96½	97	97½	98	98½	99	99½	100																																																																																																																																																																																																							
E	¾	1	1¼	1½	1¾	2	2¼	2½	2¾	3	3¼	3½	3¾	4	4¼	4½	4¾	5	5¼	5½	5¾	6	6¼	6½	6¾	7	7¼	7½	7¾	8	8¼	8½	8¾	9	9¼	9½	9¾	10	10¼	10½	10¾	11	11¼	11½	11¾	12	12¼	12½	12¾	13	13¼	13½	13¾	14	14¼	14½	14¾	15	15¼	15½	15¾	16	16¼	16½	16¾	17	17¼	17½	17¾	18	18¼	18½	18¾	19	19¼	19½	19¾	20	20¼	20½	20¾	21	21¼	21½	21¾	22	22¼	22½	22¾	23	23¼	23½	23¾	24	24¼	24½	24¾	25	25¼	25½	25¾	26	26¼	26½	26¾	27	27¼	27½	27¾	28	28¼	28½	28¾	29	29¼	29½	29¾	30	30¼	30½	30¾	31	31¼	31½	31¾	32	32¼	32½	32¾	33	33¼	33½	33¾	34	34¼	34½	34¾	35	35¼	35½	35¾	36	36¼	36½	36¾	37	37¼	37½	37¾	38	38¼	38½	38¾	39	39¼	39½	39¾	40	40¼	40½	40¾	41	41¼	41½	41¾	42	42¼	42½	42¾	43	43¼	43½	43¾	44	44¼	44½	44¾	45	45¼	45½	45¾	46	46¼	46½	46¾	47	47¼	47½	47¾	48	48¼	48½	48¾	49	49¼	49½	49¾	50	50¼	50½	50¾	51	51¼	51½	51¾	52	52¼	52½	52¾	53	53¼	53½	53¾	54	54¼	54½	54¾	55	55¼	55½	55¾	56	56¼	56½	56¾	57	57¼	57½	57¾	58	58¼	58½	58¾	59	59¼	59½	59¾	60	60¼	60½	60¾	61	61¼	61½	61¾	62	62¼	62½	62¾	63	63¼	63½	63¾	64	64¼	64½	64¾	65	65¼	65½	65¾	66	66¼	66½	66¾	67	67¼	67½	67¾	68	68¼	68½	68¾	69	69¼	69½	69¾	70	70¼	70½	70¾	71	71¼	71½	71¾	72	72¼	72½	72¾	73	73¼	73½	73¾	74	74¼	74½	74¾	75	75¼	75½	75¾	76	76¼	76½	76¾	77	77¼	77½	77¾	78	78¼	78½	78¾	79	79¼	79½	79¾	80	80¼	80½	80¾	81	81¼	81½	81¾	82	82¼	82½	82¾	83	83¼	83½	83¾	84	84¼	84½	84¾	85	85¼	85½	85¾	86	86¼	86½	86¾	87	87¼	87½	87¾	88	88¼	88½	88¾	89	89¼	89½	89¾	90	90¼	90½	90¾	91	91¼	91½	91¾	92	92¼	92½	92¾	93	93¼	93½	93¾	94	94¼	94½	94¾	95	95¼	95½	95¾	96	96¼	96½	96¾	97	97¼	97½	97¾	98	98¼	98½	98¾	99	99¼	99½	99¾	100
F	1¼	1½	1¾	2	2¼	2½	2¾	3	3¼	3½	3¾	4	4¼	4½	4¾	5	5¼	5½	5¾	6	6¼	6½	6¾	7	7¼	7½	7¾	8	8¼	8½	8¾	9	9¼	9½	9¾	10	10¼	10½	10¾	11	11¼	11½	11¾	12	12¼	12½	12¾	13	13¼	13½	13¾	14	14¼	14½	14¾	15	15¼	15½	15¾	16	16¼	16½	16¾	17	17¼	17½	17¾	18	18¼	18½	18¾	19	19¼	19½	19¾	20	20¼	20½	20¾	21	21¼	21½	21¾	22	22¼	22½	22¾	23	23¼	23½	23¾	24	24¼	24½	24¾	25	25¼	25½	25¾	26	26¼	26½	26¾	27	27¼	27½	27¾	28	28¼	28½	28¾	29	29¼	29½	29¾	30	30¼	30½	30¾	31	31¼	31½	31¾	32	32¼	32½	32¾	33	33¼	33½	33¾	34	34¼	34½	34¾	35	35¼	35½	35¾	36	36¼	36½	36¾	37	37¼	37½	37¾	38	38¼	38½	38¾	39	39¼	39½	39¾	40	40¼	40½	40¾	41	41¼	41½	41¾	42	42¼	42½	42¾	43	43¼	43½	43¾	44	44¼	44½	44¾	45	45¼	45½	45¾	46	46¼	46½	46¾	47	47¼	47½	47¾	48	48¼	48½	48¾	49	49¼	49½	49¾	50	50¼	50½	50¾	51	51¼	51½	51¾	52	52¼	52½	52¾	53	53¼	53½	53¾	54	54¼	54½	54¾	55	55¼	55½	55¾	56	56¼	56½	56¾	57	57¼	57½	57¾	58	58¼	58½	58¾	59	59¼	59½	59¾	60	60¼	60½	60¾	61	61¼	61½	61¾	62	62¼	62½	62¾	63	63¼	63½	63¾	64	64¼	64½	64¾	65	65¼	65½	65¾	66	66¼	66½	66¾	67	67¼	67½	67¾	68	68¼	68½	68¾	69	69¼	69½	69¾	70	70¼	70½	70¾	71	71¼	71½	71¾	72	72¼	72½	72¾	73	73¼	73½	73¾	74	74¼	74½	74¾	75	75¼	75½	75¾	76	76¼	76½	76¾	77	77¼	77½	77¾	78	78¼	78½	78¾	79	79¼	79½	79¾	80	80¼	80½	80¾	81	81¼	81½	81¾	82	82¼	82½	82¾	83	83¼	83½	83¾	84	84¼	84½	84¾	85	85¼	85½	85¾	86	86¼	86½	86¾	87	87¼	87½	87¾	88	88¼	88½	88¾	89	89¼	89½	89¾	90	90¼	90½	90¾	91	91¼	91½	91¾	92	92¼	92½	92¾	93	93¼	93½	93¾	94	94¼	94½	94¾	95	95¼	95½	95¾	96	96¼	96½	96¾	97	97¼	97½	97¾	98	98¼	98½	98¾	99	99¼	99½	99¾	100		
G	1½	1¾	2	2¼	2½	2¾	3	3¼	3½	3¾	4	4¼	4½	4¾	5	5¼	5½	5¾	6	6¼	6½	6¾	7	7¼	7½	7¾	8	8¼	8½	8¾	9	9¼	9½	9¾	10	10¼	10½	10¾	11	11¼	11½	11¾	12	12¼	12½	12¾	13	13¼	13½	13¾	14	14¼	14½	14¾	15	15¼	15½	15¾	16	16¼	16½	16¾	17	17¼	17½	17¾	18	18¼	18½	18¾	19	19¼	19½	19¾	20	20¼	20½	20¾	21	21¼	21½	21¾	22	22¼	22½	22¾	23																																																																																																																																																																																																																																																																																																																							

### COMPRESSION COUPLINGS

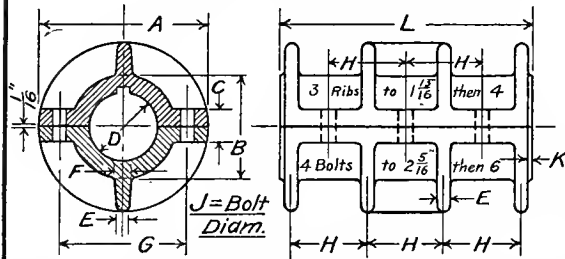

D	A	B	C	E	F	G	H	J	K	L	
15/16	1	3 1/8	1 1/2	3/4	3/16	5/16	2 1/8	1 31/32	5/16	1/16	4 1/4
1 1/16	1 1/4	3 3/4	1 15/16	13/16	1/4	3/8	2 5/8	2 3/8	3/8	1/16	5 1/8
1 1/8	1 1/2	4 1/4	2 5/16	7/8	1/4	3/8	3	2 3/4	7/16	1/8	6
1 1/4	1 3/4	4 3/4	2 11/16	1	5/16	7/16	3 7/16	3 5/16	7/16	1/8	6 7/8
1 1/2	2	5 3/8	3 1/16	1 1/8	3/8	1/2	3 7/8	2 3/8	1/2	1/8	7 3/4
1 5/8	2 1/4	5 5/8	3 7/16	1 1/4	7/16	9/16	4 5/16	2 5/8	9/16	1/8	8 9/16
2 1/16	2 1/2	6 1/8	3 13/16	1 5/16	7/16	9/16	4 3/4	2 15/16	9/16	1/8	9 1/2
2 1/8	2 3/4	7	4 3/16	1 7/16	1/2	5/8	5 3/16	3 1/4	5/8	1/8	10 1/2
2 1/4	3	7 1/2	4 9/16	1 1/2	9/16	11/16	5 5/8	3 1/2	5/8	3/16	11 7/16
2 3/8	3 1/4	8 1/8	4 15/16	1 5/8	5/8	3/4	6 1/8	3 3/4	3/4	3/16	12 1/4
2 1/2	3 1/2	8 3/4	5 5/16	1 11/16	5/8	3/4	6 5/8	4 1/16	3/4	3/16	13 3/16
2 5/8	3 3/4	9 3/8	5 11/16	1 3/4	11/16	7/16	4 3/8	4 7/8	3/16	1/4	14 3/16
3 1/16	4	9 7/8	6 1/16	1 7/8	3/4	7/8	4 5/8	5 7/8	1/4	1/4	15 1/8
3 1/8	4 1/4	10 1/16	6 1/2	2	3/4	7/8	4 15/16	6 7/8	1/4	1/4	16 1/16
3 1/4	4 1/2	11	6 7/8	2 1/16	13/16	15/16	8 3/8	5 1/4	1	1/4	17 1/16
3 3/8	4 5/8	12	7 1/8	2 1/4	15/16	1	9 1/4	5 5/8	1	5/16	19

### SOLID JOURNAL BOXES

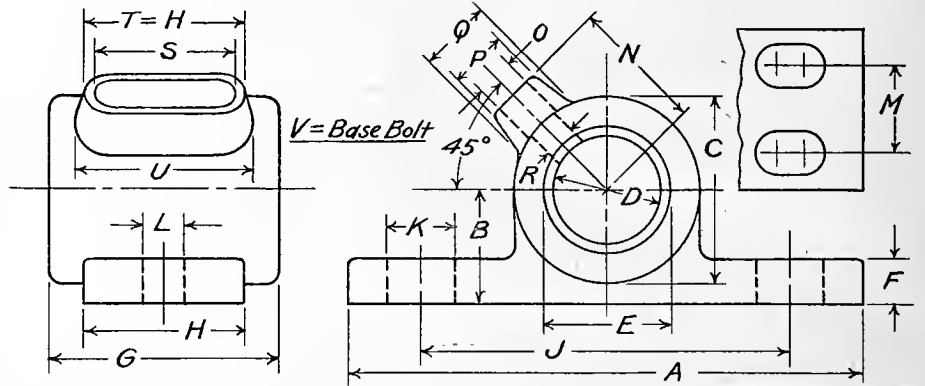

D	A	B	C	E	F	G	H	J	K	L	M	N	O	P	Q	R	S	U	V
15/16	4 7/8	1	1 5/8	1/8	1/2	2	1 3/8	3 1/2	5/8	7/16		1 1/4	1/4	3/8	1/2	1/4	1 1/4	1 1/2	3/8
1 1/16	6 1/8	1 1/4	2 1/16	1 7/16	9/16	2 1/2	1 3/4	4 1/4	7/8	9/16		1 1/2	7/16	5/8	3/4	3/8	1 9/16	7/8	1 1/2
1 1/8	6 3/4	1 1/2	2 7/16	1 11/16	5/8	3	2 1/8	4 7/8	7/8	9/16		1 3/4	1/2	3/4	15/16	7/16	1 7/8	2 5/16	1 1/2
1 1/4	7 7/8	1 3/4	2 13/16	1 15/16	5/8	3 1/2	2 1/2	5 1/2	1 1/8	3/4		2	5/8	7/8	1/16	1/2	2 1/4	2 11/16	5/8
1 1/2	8 1/2	2	3 3/16	2 1/4	3/4	4	2 7/8	6	1 1/8	3/4		2 1/4	5/8	7/8	1/8	1/2	2 5/8	3 1/8	5/8
1 5/8	9	2 1/4	3 9/16	2 1/2	3/4	4 1/2	3 1/4	6 1/2	1 1/8	3/4		2 1/2	5/8	7/8	1/8	1/2	3	3 1/2	5/8
2 1/16	9 1/2	2 1/2	3 15/16	2 3/4	7/8	5	3 11/16	7	1 1/8	3/4		2 3/4	3/4	1	1/4	9/16	3 7/16	3 15/16	5/8
2 1/8	10 3/8	2 3/4	4 1/4	3 1/16	7/8	5 1/2	4 1/8	7 5/8	1 1/4	7/8		3	3/4	1	1/4	9/16	3 7/8	4 3/8	3/4
2 1/4	11	3	4 5/8	3 5/16	15/16	6	4 1/2	8 1/8	1 1/4	7/8		3 1/4	3/4	1 1/8	1 3/8	9/16	4 1/8	4 3/4	3/4
2 3/8	11 1/2	3 1/4	5	3 9/16	1	6 1/2	4 7/8	8 5/8	1 1/4	7/8	2 3/4	3 1/2	7/8	1 1/4	1 9/16	5/8	4 1/2	5 3/16	3/4
2 1/2	12	3 1/2	5 1/16	3 13/16	1	7	5 1/4	9 1/8	1 1/4	7/8	3	3 3/4	7/8	1 1/4	1 9/16	5/8	4 7/8	5 9/16	3/4
2 5/8	12 1/2	3 3/4	5 11/16	4 1/16	1 1/8	7 1/2	5 5/8	9 5/8	1 1/4	7/8	3 1/4	4	7/8	1 1/4	1 9/16	5/8	5 1/4	5 15/16	3/4
3 1/16	12 7/8	4	6	4 3/8	1 1/8	8	6	10	1 1/4	7/8	3 1/2	4 1/4	1	1 3/8	1 3/4	2 1/2	5 5/8	6 3/8	3/4

Table No. 17

# RIGID PILLOW BLOCKS

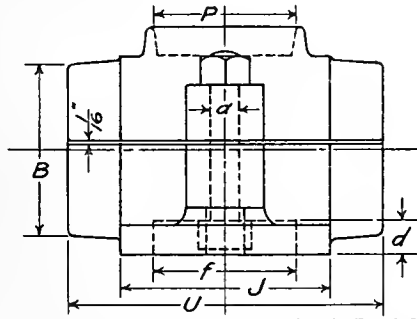
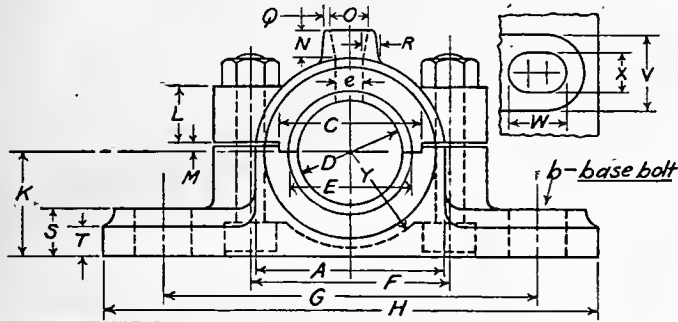

# PLAIN SHAFT COLLARS

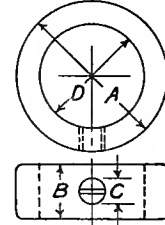

D	A	B	C	E	F	G	H	J	K	L	M	N	O	P	Q	R	S	T	U	V	W	X	Y	a	b	d	e	f	D	A	B	C
1	1 1/8	1/2	1 3/8	1 3/8	1 3/4	3/2	4 3/4	2	1	1/2	1/8	1/4	1/4	1 1/8	1/8	1/2	1/4	3	1 5/8	1/2	1/2	3/8	5/16	3/8	3/8	1/4	1 3/8	1	1 5/8	7/8	3/8	
1 1/8	1 3/8	1 1/8	1 1/2	1 3/8	2	4	5 3/8	2 1/2	1 1/8	9/16	1/8	1/4	3/8	1 3/4	1/8	1/2	3/8	1 1/4	1 5/8	3/4	1/2	1	3/8	3/8	1/16	3/8	1 1/2	1 1/8	1 3/8	1 1/8	3/8	
1 1/4	2 1/8	1 3/8	1 5/8	1 1/2	2 1/4	4 3/8	6	2 1/2	1 1/4	5/8	1/8	1/4	3/8	1 1/2	3/32	3/8	5/8	3/8	3 3/4	1	3/4	1/2	1 3/8	3/8	3/8	1/16	3/8	1 1/2	1 1/4	2	1	3/8
1 3/8	2 3/8	2 1/8	1 3/4	1 5/8	2 1/2	4 7/8	6 1/2	2 3/4	1 3/8	3/4	1/8	3/8	1/2	1 7/8	3/32	3/8	5/8	3/8	4 1/8	1	3/4	1/2	1 1/4	3/8	3/8	1/16	3/8	1 1/8	1 3/8	2 1/8	1	3/8
1 1/2	2 5/8	2 3/8	2	1 3/4	2 5/8	5 1/4	7	3	1 1/2	3/4	1/8	3/8	1/2	2 3/8	1/8	1/4	3/4	3/8	4 1/2	1	3/4	1/2	1 3/8	3/8	3/8	1/16	3/8	2	1 1/2	2 1/8	1 1/8	1/2
1 5/8	2 7/8	2 1/2	2 1/4	1 7/8	3	5 3/4	7 3/4	3 1/4	1 5/8	7/8	1/8	1/2	5/8	2 5/8	1/8	1/4	3/4	3/8	4 7/8	1 1/8	1 5/8	1/2	1 1/2	3/8	3/8	1/16	3/8	2 1/8	1 5/8	2 1/8	1 1/8	1/2
1 3/4	3	2 3/4	2 3/8	2	3 1/4	6 1/8	8 1/4	3 1/2	1 3/4	7/8	1/8	1/2	3/8	2 3/4	1/8	1/4	7/8	7/16	5 1/4	1 3/8	1 5/8	3/8	1 1/8	1/2	1/2	3/16	7/16	2 3/8	1 3/4	2 1/8	1 1/8	1/2
1 7/8	3 1/4	2 7/8	2 1/2	2 1/8	3 3/8	6 1/2	9	3 3/4	1 7/8	1 5/16	3/16	1/2	5/8	3	1/8	1/4	7/8	7/16	5 5/8	1 3/8	1 5/8	3/4	1 3/4	1/2	5/8	3/16	7/16	2 3/4	1 7/8	2 1/8	1 3/16	1/2
2	3 3/8	3	2 5/8	2 5/8	3 3/8	7	9 1/2	4	2	1	3/16	1/2	5/8	3	1/8	1/4	1	1/2	6	1 3/8	1	3/4	1 3/4	5/8	5/8	1/16	7/16	2 1/8	2	3	1 1/4	1/2
2 1/4	3 3/8	3 3/8	2 7/8	2 9/16	4	7 1/8	10 3/4	4 1/2	2 1/4	1 1/8	3/16	1/2	5/8	3 1/2	1/8	1/4	1 1/8	1/2	6 3/4	1 3/8	1 3/8	3/4	1 5/8	5/8	5/8	1/16	7/16	3	2 1/4	3 3/8	1 5/16	5/8
2 1/2	4 1/8	3 5/8	3 3/8	2 13/16	4 3/8	8 3/4	12	5	2 1/2	1 1/16	3/16	5/8	1 3/16	4	1/8	1/4	1 1/4	1/2	7 1/2	1 1/2	1 1/4	7/8	2 1/16	3/4	3/4	1 3/16	1/2	3 1/4	2 1/2	3 1/16	1 3/8	5/8
2 3/4	4 3/8	4	3 1/2	3 1/8	4 1/8	9 3/8	13	5 1/2	2 3/4	1 3/16	1/4	3/8	1 3/16	4	1/8	1/4	1 3/8	5/8	8 1/4	1 3/4	1 1/4	1	2 3/16	3/4	7/8	1 3/16	1/2	3 3/8	2 3/4	4	1 1/16	5/8
3	5 1/8	4 3/8	3 3/8	3 3/8	5 1/4	10 1/2	14 1/4	6	3	1 1/2	5/16	5/8	7/8	4 1/2	3/16	3/8	1 1/2	3/4	9	1 7/8	1 3/4	1	2 3/16	7/8	7/8	1	3/8	4 1/8	3	4 3/8	1 1/2	5/8
3 1/4	5 5/8	4 3/8	4 1/4	3 5/8	5 5/8	11 3/8	15 1/2	6 1/2	3 1/4	1 5/8	5/16	3/4	7/8	5	3/16	3/8	1 5/8	3/4	9 3/4	2	1 3/4	1	2 13/16	7/8	7/8	1	5/8	4 1/8	3 1/4	4 3/4	1 5/8	5/8
3 1/2	6 1/4	5 3/8	4 1/2	3 1/8	6 1/2	12 1/4	16 3/4	7	3 1/2	1 3/4	3/8	3/4	7/8	5 1/2	3/16	3/8	1 3/4	7/8	10 1/2	2 1/8	1 3/4	1 1/8	3	7/8	1	1	5/8	4 1/2	3 1/2	5 1/8	1 5/8	5/8
3 3/4	6 3/8	5 3/8	4 7/8	4 1/8	6 3/4	13 1/8	17 3/4	7 1/2	3 3/4	1 7/8	3/8	3/4	7/8	6	3/16	3/8	1 5/8	1 1/2	11 1/4	2 1/4	1 1/8	1 1/4	3 1/8	1	1 1/8	1 1/8	5/8	4 1/2	3 3/4	5 1/8	1 3/4	3/4
4	7	6	5	4 1/8	7 1/4	14	19	8	4	2	2 3/8	7/8	1	6 1/2	3/16	3/8	2	1	12	2 3/8	2	1 1/2	3 1/2	1	1 1/8	1 1/8	2 1/2	4 3/4	4	5 5/8	1 3/8	3/4
4 1/4	7 1/4	6 1/4	5 1/2	4 7/8	7 3/4	14 1/8	20 1/4	8 1/2	4 1/4	2 1/8	3/8	7/8	1	6 3/4	1/4	1/2	2 1/8	1 1/8	12 3/4	2 3/8	2 1/8	1 3/8	3 3/8	1 1/8	1 1/4	1 1/4	2 5/8	5 1/8	4 1/4	6 1/8	1 7/8	3/4
4 1/2	7 3/8	6 1/2	6	5	7 7/8	15 3/4	21 1/4	9	4 1/2	2 1/4	3/8	1	1	7	1/4	1/2	2 1/4	1 1/8	13 1/2	2 7/8	2 1/4	1 1/2	3 3/8	1 1/4	1 1/4	1 3/8	2 5/8	6	4 1/2	6 1/2	2	3/4
5	8 1/8	7 1/8	6 1/2	5 1/2	8 3/4	17 1/2	23 3/4	10	5	2 1/2	3/8	1	1 3/8	7	1/4	1/2	2 1/2	1 1/4	15	3 1/4	2 1/2	1 1/2	4 1/8	1 1/4	1 3/8	1 3/8	2 3/4	6 3/4	5	7 1/8	2 1/8	3/4

# ANGLE PILLOW BLOCKS

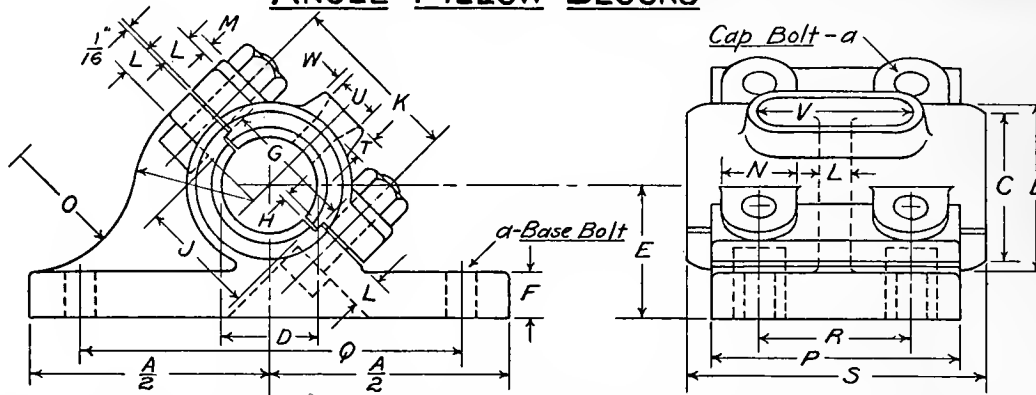

# SAFETY SHAFT COLLARS

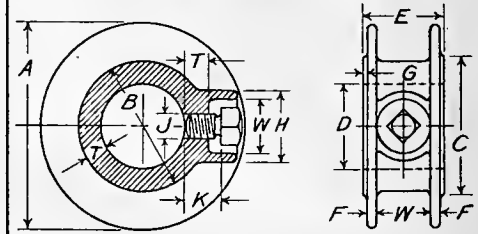

D	A	B	C	E	F	G	H	J	K	L	M	N	O	P	Q	R	S	T	U	V	W	a
15/16	5 3/4	1 5/8	1 1/2	1 1/2	1 1/2	1 3/8	1/8	1 3/8	1 7/8	3/8	1/8	15/16	1 1/4	3	4 1/2	1 3/4	3	1/4	1/4	1 1/8	1 1/8	3/8
1 1/16	6 1/4	2 1/8	1 7/8	1 3/4	5/8	1 5/8	1/8	1 1/2	2 1/4	7/16	3/16	15/16	1 1/2	3 1/4	5	2	3 3/4	1/4	7/16	1 7/8	3/32	3/8
1 7/16	7 1/2	2 5/8	2 3/8	2 3/16	3/4	2	1/8	1 3/4	2 7/8	1/2	1/4	1 1/16	1 3/4	3 5/8	6	2 1/8	4 1/2	3/8	1 1/2	2 3/8	1/8	1 1/2
1 11/16	8 3/8	3	2 3/4	2 3/8	3/4	2 3/8	1/8	2	3 1/4	5/8	1/4	1 3/16	2	4	6 1/2	2 3/8	5 1/4	1 1/2	5/8	2 3/4	1/8	1 1/2
1 15/16	8 3/4	3 3/8	3	2 9/16	7/8	2 5/16	3/16	2 5/16	3 3/8	3/4	1/4	1 3/16	2 1/2	4 3/8	7	2 5/8	6	1 1/2	5/8	3	1/8	1 1/2
2 3/16	9 7/8	3 7/8	3 3/8	2 13/16	7/8	2 7/8	3/16	2 9/16	4	13/16	1/4	1 1/2	3	4 3/4	7 7/8	2 3/4	6 3/4	1 1/2	5/8	3 1/2	1/8	5/8
2 7/16	10 1/2	4 1/8	3 5/8	3	15/16	3 1/8	3/16	2 13/16	4 1/4	13/16	1/4	1 1/2	3 1/2	5	8 3/8	2 7/8	7 1/2	5/8	13/16	4	1/8	5/8
2 11/16	11 1/4	4 5/8	4	3 1/4	15/16	3 1/2	1/4	3 1/8	4 3/4	7/8	5/16	1 1/2	4	5 1/2	9	3 1/4	8 1/4	5/8	13/16	4 1/4	1/8	5/8
2 15/16	13	5 1/8	4 3/8	3 9/16	1	3 7/8	5/16	3 3/8	5 1/4	1	3/8	1 3/4	4 1/2	6	10 1/2	3 1/2	9	5/8	7/8	4 1/2	3/16	3/4
3 1/16	14 1/4	6 1/4	5 3/8	4 3/16	1 1/16	4 1/4	3/8	3 7/8	6 1/4	1 1/8	7/16	1 3/4	5	7	11 1/2	4 1/4	10 1/2	3/4	7/8	5 1/4	3/16	3/4
3 5/16	15 1/2	7	6	4 5/8	1 1/8	5	3/8	4 7/16	7	1 1/4	1/2	1 3/4	5 1/2	8	12 1/2	5	12	7/8	1	6	3/16	3/4
4 1/16	17 1/4	7 5/8	6 5/8	5 5/16	1 1/2	6	3/8	5	7 3/4	1 3/8	5/8	2 1/8	6	9	14	5 3/4	13 1/2	1 1/8	1	6 1/2	1/4	7/8
4 5/16	18 1/2	8 1/8	7 1/8	5 9/16	1 1/2	6 1/2	3/8	5 1/2	8 1/4	1 3/8	5/8	2 1/8	6 1/2	10	15	6 1/2	15	1 1/4	1 3/8	7	1/4	7/8

Table No. 19

## PULLEY PROPORTIONS

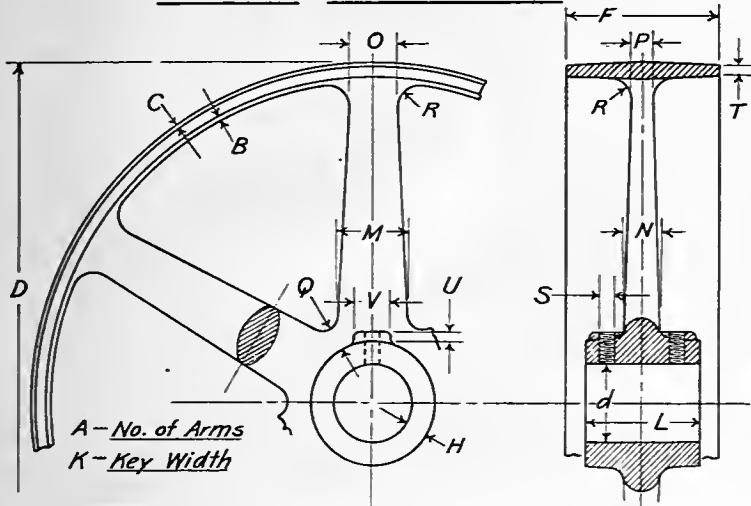

Assume  $D-F-d-A$

$$B = \frac{F}{48} \quad C = \frac{F}{96} \text{ to } \frac{F}{48} \quad H = \frac{D+2F}{52} + \frac{1}{8} \quad K = \frac{d}{4}$$

$$L = \frac{2}{3}F \text{ to } F \quad M = \sqrt[3]{\frac{FD}{4A}} \text{ (Sing. Belt)} \quad M = \sqrt[3]{\frac{FD}{2A}} \text{ (Doub. Belt)}$$

$$N = \frac{M}{2} \quad O = \frac{2}{3}M \text{ to } \frac{3}{4}M \quad P = \frac{O}{2} \quad Q = \frac{5}{16}d \quad R = \frac{M}{4}$$

$$S = \frac{3}{16}d \quad T = \frac{D+F}{200} + \frac{1}{16} \text{ (Sing. Belt)} \quad T = \frac{D+F}{200} + \frac{3}{16} \text{ (Doub. Belt)}$$

$$U = \frac{d}{8} \quad V = \frac{d}{2}$$

## SPUR GEAR PROPORTIONS

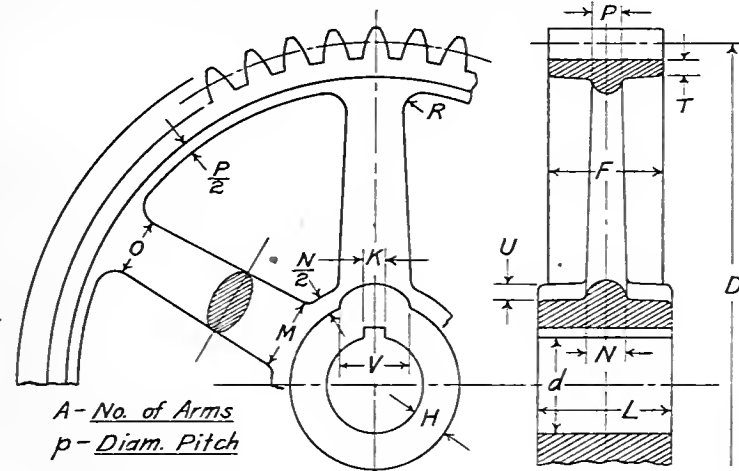

Assume  $D-p-d-A$

$$F - \text{See values below} \quad H = \sqrt[3]{\frac{FD}{17.2p}} \quad K = \frac{d}{4}$$

$$L = F + \frac{D}{40} \quad M = \sqrt[3]{\frac{2.5FD}{Ap}} \quad N = \frac{M}{2} \quad O = \frac{2}{3}M \text{ to } \frac{3}{4}M$$

$$P = \frac{O}{2} \quad T = \frac{3}{2}p \quad U = \frac{K}{2} + \frac{1}{8} \quad V = 3K$$

P	1	1/4	1/2	3/4	2	2 1/2	3	3 1/2	4	5	6	8
F	9"	7 1/2"	6 1/2"	5 1/2"	4 1/2"	3 3/4"	3 1/4"	2 3/4"	2 1/2"	2"	1 1/2"	1 1/4"

## WEIGHTS OF MATERIALS

Material	Pounds per Cu. Ft. Cu. In	Material	Pounds per Cu. Ft.
<b>Metals</b>			
Aluminum	166	Stone, Brick, etc.	125
Antimony	421	Brick, Common Hard	140-150
Bismuth	612	“ Fire	100-140
Brass, Sheet	527	Brickwork	88-110
“ Wire	533	Cement, Portland	120-150
“ Cast	505	Clay	120-140
Bronze	534	Concrete	72-80
	to	Earth, Loose	90-110
	to	“ Rammed	160-170
Copper, Sheet	561	Gneiss and Granite	100-120
“ Wire	549	Gravel	160-180
“ Cast	554	Limestone and Marble	140-160
Gold	537	Masonry, Rubble	140-170
Iron, Cast	1201	“ Dressed	100-130
Iron, Wrought	432	Mud, Wet	90-120
Lead	485	Sand	140-150
Mercury at 32° F.	710	Sandstone	170-180
“ at 212° F.	849	Slate	170-200
Platinum	834	Trap	55-65
Silver	1347	“ Fuels	84
Steel	655	Anthracite, Loose	50-55
Zinc, Sheet	490	Bituminous Coal, Solid	15-20
“ Cast	449	“ “ Broken	23-32
	428	Charcoal	55
<b>Woods (Dry timber)</b>		Coke	
Ash	45	Petroleum	
Boxwood	62	<b>Miscellaneous</b>	
Chestnut	41	Air at 60° F. 14.7 lbs.	.0765
Cork	15	atmos. press.	40-45
Ebony	76	Ashes from soft coal	156-172
Elm	35	Glass	57.5
Hemlock	25	Ice	5-50
Hickory	53	Snow	
Mahogany, Spanish	53	Water at 62° F. and	62.355
“ Honduras	35	Bar. at 30"	
Maple	49		
Oak, White	50		
Pine, White	24		
“ Southern Yellow	38		
Spruce	25		
Sycamore	37		
Teak	51		

## INDEX

	SECTION		SECTION
Addendum, tooth . . . . .	134	Bond paper . . . . .	86
A. L. A. M. bolts and nuts . . . . .	Tab. 4	Books on lettering . . . . .	318
Alterations, blue prints . . . . .	89	"    "    toothed gears . . . . .	150
"    lettering . . . . .	317	Broken ends . . . . .	26
Anchor bolts . . . . .	107	Building plan . . . . .	176
Angle gears . . . . .	149	Button head . . . . .	114, 121
"    valve . . . . .	130	Cabinet projection . . . . .	8, 264-266, 274
Angles, specifying . . . . .	57, 68	"    "    exercises . . . . .	267
structural . . . . .	169, 175, Tab. 14	Cap screws . . . . .	112-114, Tabs. 2, 3
Architectural lettering . . . . .	296, 301	Castings . . . . .	41
Arrows . . . . .	47	Cast washers . . . . .	Tab. 10
Artists' perspective . . . . .	6, 210, 270	Center lines . . . . .	36
A. S. M. E. Stand. screws . . . . .	117, Tab. 5	Chain . . . . .	78, 252
Assembly drawings . . . . .	21	Channel . . . . .	169, 175
Axometric . . . . .	10, 230-257	Checking drawings . . . . .	206
"    cube . . . . .	233	Check valve . . . . .	130
"    exercises . . . . .	258	Chord . . . . .	175
Ball handles . . . . .	Tab. 9	Circle, division of . . . . .	198, 199
B. & S. tapers . . . . .	132, Tab. 13	Circular mil . . . . .	78
Batten plate . . . . .	175	Circular pitch . . . . .	134-137
Belting . . . . .	78	Clearance, rivet . . . . .	165, 174, Tab. 14
Bend, pipe . . . . .	130	"    tooth . . . . .	134, 137
Bevel gears . . . . .	142	Clevis . . . . .	175
Bevels, structural . . . . .	159	Clip angle . . . . .	175
Bill of material . . . . .	84	Clutch coupling . . . . .	Tab. 15
Birm. wire gage . . . . .	133	Coach screw . . . . .	119
Black printing . . . . .	90	Collar screw . . . . .	115, Tab. 4
Blue printing . . . . .	86	Compression coupling . . . . .	Tab. 17
Blueprints, alterations . . . . .	89	Coping, structural . . . . .	175
Bolt, A. L. A. M. . . . .	Tab. 4	Cotter . . . . .	126, 127, Tab. 10
"    eye . . . . .	Tab. 10	"    pin . . . . .	175
"    general . . . . .	106	Countersunk head . . . . .	114, 121
"    manuf. stand . . . . .	110	Coupling, pipe . . . . .	130
"    U. S. stand. . . . .	109, 110, Tab. 1	"    shaft . . . . .	Tabs. 15, 16, 17

	SECTION		SECTION
Cover plate . . . . .	175	Flats . . . . .	175
Crimped angle, struct. . . . .	175	Forging . . . . .	39
Cross hatching . . . . .	33, 35	Foundry plan . . . . .	176
Cross, pipe . . . . .	130	Gage, machine screw . . . . .	Tab. 5
Cross section paper . . . . .	202	" steel wire . . . . .	133, Tab. 5
Cross valve . . . . .	130	" twist drill . . . . .	Tab. 5
Cycloidal teeth . . . . .	138	" U. S. sheet metal . . . . .	78, 133
Decimal equivalents . . . . .	Tab. 1	" wood screw . . . . .	Tab. 5
Dedendum, tooth . . . . .	134, 137	Gage lines . . . . .	164, 175, Tab. 14
Detail drawing . . . . .	21	Gages . . . . .	133
Diametral pitch . . . . .	135	Gate valve . . . . .	130
Dimensioning . . . . .	37-72, 173	Gear books . . . . .	150
Dimension figures . . . . .	58-64	Gearing, toothed . . . . .	134-150, Tab. 20
" lines . . . . .	44, 46, 53, 173	Gear teeth . . . . .	134-139
" location . . . . .	72	Gib head key . . . . .	122, Tab. 6
" selection . . . . .	38	Globe valve . . . . .	130
Dotted lines . . . . .	29	Gusset plates . . . . .	170, 175
Drilled holes . . . . .	78	Hand wheels . . . . .	Tab. 8
Elbow, pipe . . . . .	130	Handles, machine . . . . .	Tabs. 8, 9
" axometric of . . . . .	251	Hanger, shaft . . . . .	78
Electrical symbols . . . . .	208	Hatching, cross . . . . .	33
Elevation . . . . .	18	Helix angle . . . . .	146
Ellipse isometric . . . . .	260	Hitch angle, struct. . . . .	175
" sketching . . . . .	200	Horizon line . . . . .	218
Exercises . . . . .	207, 229, 258, 263, 267	Horizontal projection . . . . .	18
Extension lines . . . . .	48	H section . . . . .	175
Eye bar . . . . .	175	I beam . . . . .	169, 175
" bolt . . . . .	Tab. 10	Involute teeth . . . . .	138
Face of tooth . . . . .	134	Isometric drawing . . . . .	12, 259-262, 272
Field rivets . . . . .	175	" exercises . . . . .	263
Filler, structural . . . . .	171, 175	" paper . . . . .	262
Filletlets on castings . . . . .	41	" pipe drawing . . . . .	131
Fillet, tooth . . . . .	134	" projection . . . . .	11
Fillister head . . . . .	113	Jarno taper . . . . .	132
Finish marks . . . . .	41	Jaw clutch coupling . . . . .	Tab. 15
Flange coupling . . . . .	Tab. 16	Journal box . . . . .	Tab. 17
Flange, structural . . . . .	175	Keys . . . . .	122, Tabs. 1, 6
Flank of tooth . . . . .	134		



	SECTION
Keys Whitney or Woodruff . . . . .	124, Tab. 1
Knobs, machine . . . . .	Tab. 7
Knurled head . . . . .	111
Lacing . . . . .	175
Lag screw . . . . .	119
Lateral pin . . . . .	175
Lattice bars . . . . .	172, 175
Laying out floor . . . . .	152
Lead of a screw thread . . . . .	103
Lengths, estimating . . . . .	180
Lettering . . . . .	284
Alphabets . . . . .	296-297
Alterations . . . . .	317
Books on . . . . .	318
Mechanical . . . . .	285
Photo reproduction . . . . .	315, 316
Practice work . . . . .	303-314
Principles . . . . .	288-295
Titles . . . . .	298-302
Linear perspective . . . . .	5, 209, 217, 269
Line shading . . . . .	277-283
Lines of a drawing . . . . .	80-81
Center lines . . . . .	36, 81
Dimension lines . . . . .	44, 81, 173
Dotted lines . . . . .	29, 81
Extension lines . . . . .	48, 81
Shade lines . . . . .	275, 276
Lug angle . . . . .	175
Machine handles . . . . .	Tab. 9
" screws . . . . .	78, 117, Tab. 5
Map titles . . . . .	300
Materials, weight of . . . . .	Tab. 21
Mitre gears . . . . .	149
Model drawing . . . . .	222-227
Morse tapers . . . . .	132, Tab. 13
Nominal sizes . . . . .	78
Normal pitch . . . . .	145
Notes appended to drawings . . . . .	74

	157
	SECTION
Nuts, standard . . . . .	109, 110, Tab. 1
Oblique projection . . . . .	7, 273
Old English . . . . .	297
Open holes, struct. . . . .	161, 175
Orthographic projection . . . . .	9
Outlet, pipe fitting . . . . .	130
Panel, struct. . . . .	175
" point . . . . .	175
Perspective, artists' . . . . .	6, 210, 270
" linear . . . . .	5, 209, 269
" principles . . . . .	211-221
Picture plane . . . . .	5
Pillow blocks . . . . .	78, Tabs. 18-19
Pin plate . . . . .	175
Pipe drawing . . . . .	131
Pipe, standard . . . . .	78, 129, Tab. 11
Pipe fittings . . . . .	130, Tab. 12
Pitch line of gears . . . . .	134
Pitch of gear teeth . . . . .	134-137, 145
Pitch of rivets . . . . .	167, 175
Pitch of roof . . . . .	175
Pitch of thread . . . . .	102
Plan view . . . . .	18
Plotting curves . . . . .	201, 241
Plug, pipe fitting . . . . .	130
Positive prints . . . . .	90
Projection, cabinet . . . . .	8, 264-266, 274
" horizontal . . . . .	18
" isometric . . . . .	11
" oblique . . . . .	7, 273
" orthographic . . . . .	9, 271
" profile . . . . .	18
" sketches . . . . .	202-205, 207
" third angle . . . . .	15
" vertical . . . . .	18
Pulleys . . . . .	41, 78, Tab. 20
Purlin, struct. . . . .	175
Rack . . . . .	141

	SECTION
Railing fittings . . . . .	Tab. 12
Reducing coupling . . . . .	130
Return bend, pipe . . . . .	130
Riser, pipe . . . . .	131
Rivets . . . . .	121
Rivet clearances . . . . .	Tab. 14
" dimensions . . . . .	Tab. 14
" signs . . . . .	162
" spacing . . . . .	Tab. 14
Rod and bar stock . . . . .	78
Rolled sections . . . . .	169
Rope . . . . .	78, 252
Rounded corners . . . . .	41
Run, pipe fitting . . . . .	130
Scales for drawings . . . . .	22, 23, 155
Screw, button head . . . . .	114, Tab. 3
" cap . . . . .	112, 114, Tab. 2, 3
" coach . . . . .	119
" collar . . . . .	115, Tab. 4
" countersunk . . . . .	114, Tab. 3
" drawing of . . . . .	101-104
" fillister head . . . . .	113, Tab. 3
" headless . . . . .	Tab. 2
" hexagon head . . . . .	112, Tab. 2
" knurled head . . . . .	111
" lag . . . . .	119
" lead . . . . .	98
" machine . . . . .	171, Tab. 5
" set . . . . .	116, Tab. 2
" square head . . . . .	112, Tab. 2
" wood . . . . .	120, Tab. 5
Screw gage . . . . .	Tab. 5
Screw threads, Acme . . . . .	98
" " buttress . . . . .	95, 96
" " conventional . . . . .	101
" " double . . . . .	103
" " International . . . . .	93
" " knuckle . . . . .	99

	SECTION
Screw threads left hand . . . . .	104
" " multiple . . . . .	103
" " pipe . . . . .	100, Tab. 11
" " single . . . . .	102
" " sketching . . . . .	244
" " square . . . . .	97
" " U. S. standard . . . . .	92, Tab. 1
" " Vee . . . . .	91
" " Whitworth . . . . .	94
Secondary members, struct. . . . .	175
Section lining . . . . .	33, 35
Section symbols . . . . .	34
Sections . . . . .	30
Separator . . . . .	175
Set screw . . . . .	116, Tab. 2
Shade lines . . . . .	275, 276
Shaft collars . . . . .	Tabs. 18-19
Shafting, size of . . . . .	78, Tab. 16
Sheared plate . . . . .	175
Sheaves . . . . .	78
Sheet metal gage . . . . .	78, 133
Shop rivets . . . . .	175
Sketching of angles . . . . .	181, 198, 199
" axometric . . . . .	230-257
" of circles . . . . .	191
" of cube . . . . .	224
" of ellipses . . . . .	200
" exercises . . . . .	207, 229, 258, 263, 267
" of hexagons . . . . .	189
" of irregular forms . . . . .	241, 260
" Isometric . . . . .	262
" Projection . . . . .	202
" of threads . . . . .	244
" of triangles . . . . .	187
Sole plate . . . . .	175
Specifications on drawings . . . . .	73-77
Spiral gears . . . . .	144
Splice plate . . . . .	175
Split pin . . . . .	127, Tab. 10

	SECTION
Spring cotter . . . . .	127, Tab. 10
Springs . . . . .	128
Sprockets . . . . .	78
Spur gears . . . . .	140, Tab. 20
"    "    axometric of . . . . .	257
Stay plate . . . . .	175
Straight coupling . . . . .	130
Structural drawing . . . . .	151-175
Stubs' iron wire gage . . . . .	133
Stud bolt . . . . .	106, Tab. 4
Sub titles . . . . .	73
Tap bolt . . . . .	106
Tapers . . . . .	78, 132, Tab. 13
Tapped holes . . . . .	105, Tab. 4
T bar . . . . .	169, 175
T slot . . . . .	Tab. 10
Tee, pipe fitting . . . . .	130
Templets . . . . .	152
Third angle projection . . . . .	15
Through bolt . . . . .	106
Tie plate . . . . .	175
Titles . . . . .	298-302
Tooth angle . . . . .	146
Tooth proportions . . . . .	137
Tracing cloth . . . . .	86
Truss . . . . .	175
Tubing . . . . .	78
Twist drill gage . . . . .	133, Tab. 5

	159
	SECTION
Union, pipe . . . . .	130
Universal mill plate . . . . .	175
Upset rods . . . . .	175
U. S. standard bolts . . . . .	109, 110, Tab. 1
U. S. standard gage for plate . . . . .	133
Valve, pipe . . . . .	130
Vanishing points . . . . .	217
Velocity ratio . . . . .	149
Vertical projection . . . . .	18
Views, selection of . . . . .	24
Wall brackets . . . . .	78
Washers . . . . .	118, Tabs. 9, 10
Web plate . . . . .	171, 175
Weight of materials . . . . .	Tab. 21
White lines, blue prints . . . . .	89
Whitney keys . . . . .	124, Tab. 1
Wire gage . . . . .	133
Wood screws . . . . .	78, 120
Working drawings . . . . .	19-85, 151-173, 206
Working lines . . . . .	158, 175
Worm gearing . . . . .	143
Wrought iron pipe . . . . .	129, Tab. 11
Y branch, pipe fitting . . . . .	130
Z bar . . . . .	169, 175

SEP 17 1912

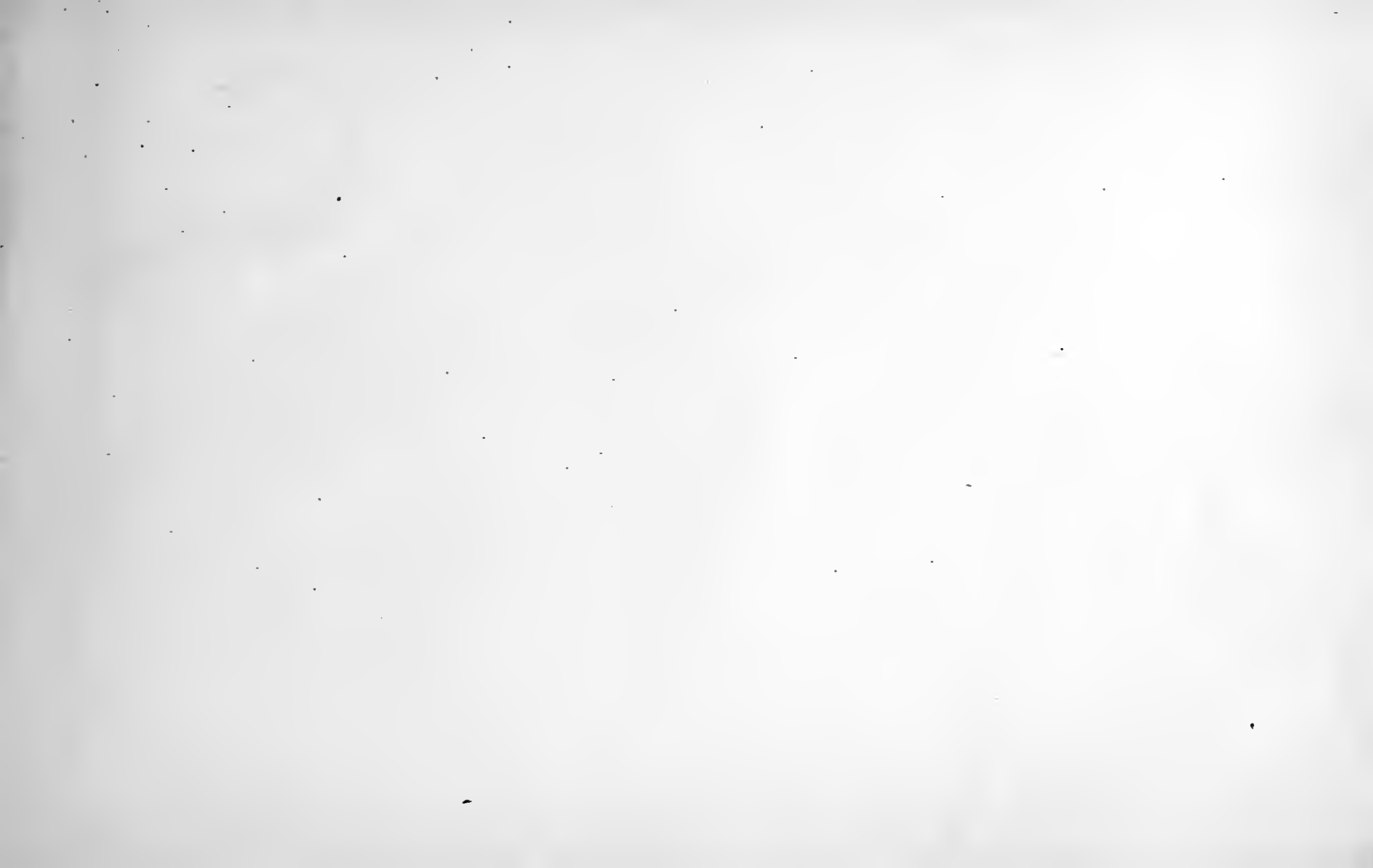





LIBRARY OF CONGRESS



0 019 936 896 5