



Class T J 265

Book G 7

Copyright N^o _____

COPYRIGHT DEPOSIT.

HEAT ENGINEERING

McGraw-Hill Book Company

Publishers of Books for

Electrical World	The Engineering and Mining Journal
Engineering Record	Engineering News
Railway Age Gazette	American Machinist
Signal Engineer	American Engineer
Electric Railway Journal	Coal Age
Metallurgical and Chemical Engineering	Power

HEAT ENGINEERING

*A TEXT BOOK OF APPLIED THERMODYNAMICS
FOR ENGINEERS AND STUDENTS
IN TECHNICAL SCHOOLS*

BY

ARTHUR M. GREENE, JR.

PROFESSOR OF MECHANICAL ENGINEERING, RUSSELL SAGE FOUNDATION
RENSSELAER POLYTECHNIC INSTITUTE; SOMETIME JUNIOR
DEAN, SCHOOL OF ENGINEERING, UNIVERSITY
OF MISSOURI

FIRST EDITION

McGRAW-HILL BOOK COMPANY, INC.

239 WEST 39TH STREET, NEW YORK

6 BOUVERIE STREET, LONDON, E. C.

1915

TJ 265
G7

COPYRIGHT, 1915, BY THE
MCGRAW-HILL BOOK COMPANY, INC.

15-6087

THE MAPLE PRESS YORK PA

MAR 22 1915

84.00

©CL.A397220

201

PREFACE

For many years the author has given lectures supplementing the text-books used as a basis for a course in heat engineering. His aim in preparing this book has been to bring together his various notes with statements of the investigations and writings of others to make a complete treatment of the important phases of this subject. In doing this he has given credit to the authors and investigators quoted. Certain of the original sources have been quoted so that the student may learn the use of references. It is hoped that many studying this book will refer to these original papers.

The work presupposes a course in theoretical thermodynamics such as that given in the treatises of Wood, Peabody or Goodenough. Because of the difference in symbols, nomenclature or point of view of various authors and to serve for reference or for the derivation of formulæ used in the text, the first chapter of this book has been written. It is not intended that this chapter shall be used as a part of the course for it is an outline only of the thermodynamic theory. It should be used to give a review of the subject or as a basis for the formulæ used. In shaping this chapter the author has been guided by his experience in teaching this subject from many texts. The treatment of availability and entropy has been based on the excellent work on thermodynamics by Goodenough.

Numerical problems have been solved at various points in the text to illustrate the principles of the subject and to apply them to actual engineering work. The problems have been solved in detail to give the student one manner of attack as well as an order for the arrangement of computations for clearness. Unless the student can apply the various formulæ and theories he has failed to attain that for which this book was written. In addition to the problems and solutions a series of questions on the various topics of the text and a set of problems illustrating their use have been placed at the end of each chapter. These may be used by the student in preparation of an assignment or by the teacher for blackboard recitations.

The author not only expresses his thanks to those whose works he has used and whose names he has placed in the first part of the index but to those whose writings he has studied as a student and teacher and whose work or whose view point he has absorbed. He especially thanks his wife, Mary E. Lewis Greene, for her aid in the preparation of manuscript, proof and final arrangement of work.

A. M. G., Jr.

SUNNYSLOPE, TROY, N. Y.,
February 22, 1915.

CONTENTS

	PAGE
PREFACE	v
LIST OF SYMBOLS	xi

CHAPTER I

FUNDAMENTAL THERMODYNAMICS	1
Availability—Graphical Representation of Heat on P. V. Plane—Scale of Temperature—Carnot Cycle—Reversed Cycle—Maximum Efficiency—Conditions for Availability of Heat—Second Law—Loss of Availability—Entropy—Entropy around a Cycle—Entropy Diagram—Characteristic Equations—Heat on a Path—Differential Equations and Relations—Perfect Gases—Differential Heat Equations for Perfect Gases—Specific Heats—Isothermal and Isodynamic Lines—Adiabatic—Thermodynamic Lines—Equality of Gas Scale and Kelvin Scale—Heat Content of Gases—Entropy of Gases—Cycles and Cross Products—Saturated Steam and Other Vapors—Intrinsic Energy—Heat on a Path—Heat Content—Entropy—Differential Effect of Heat—Superheated Vapor—Specific Heats at Constant Pressure and k 's—T-S and I-S Charts—Heat on Paths—Flow of Fluids—Throttling Action—Velocity of Various Substances—Discharge from Orifices.	

CHAPTER II

HEAT ENGINES AND EFFICIENCIES	62
Method of Reporting Performance of Engines—High-speed Non-condensing Engine—High-speed Non-condensing Compound Engine—Locomobile Engine—Pumping Engine—Steam Turbine—Producer Gas Engine—Blast-furnace Gas Engine—Diesel Oil Engine—Results of Various Tests—Topics—Problems.	

CHAPTER III

HEAT TRANSMISSION	72
Laws of Transmission—Mean Temperature Difference—Determination of K —Steam Condensers—Ammonia Condensers—Brine Coils—Evaporators and Feed-water Heaters—Heat from Liquids to Liquids—Factor of Safety—Radiators—Heat through Walls and Partitions—Efficiency of Heat Transmissions—Topics—Problems.	

CHAPTER IV

PAGE

AIR COMPRESSORS	118
Various Types—Work of Compression—Effect of Clearance—Effect of Leakage—Volumetric Efficiency—Horse-power and Power of Motor—Temperature at the end of Compression—Compression Curve—Heat Removed by Jacket—Saving due to Jacket—Water Required for Jacket—Multistaging and Intermediate Pressures—Intermediate Temperatures—Heat Removed by Intercooler—Amount of Water for Intercooler—Water Removed in Intercooler—Effect of Leakage in Multistage Compressions—Displacement of Cylinders—Size of Inlet and Outlet Pipes and Valves—Percentage Saving due to Multistaging over a Single Stage—Unavoidable Loss of Compression on Two Stages—Work on Air Engine—Loss due to Cooling after Compression—Unavoidable Loss due to Expansion Line—Loss of Pressure in Pipe Line—Loss due to Leakage from Transmission Line—Loss due to Throttling—Gain from Preheating—Power and Displacement of Air Engine or Motor—Fan Blowers—Governing—Motors—Losses in Transmission—Logarithmic Diagrams—Table of Power—Topics—Problems.	

CHAPTER V

THE STEAM ENGINE	167
Action of Steam Engine—Cycle of Steam Engine—Heat and Efficiency of Cycle—Steam Consumption—Temperature-Entropy Diagrams—Effects of Changes—Calorimeters—Analysis of Tests—Hirn's Analysis—Temperature Entropy Analysis—Missing Quantity and Initial Condensation—Experiments of Effect of Cylinder Walls—Valve Leakage—Steam Consumption by Clayton's Method—Values of N for Expansion Lines—Expansion Lines—Use of Rectangular Hyperbola—Construction of Expansion Curves—Mean Effective Pressure—Real and Apparent Ratio of Expansion—Stumpf Engine—Size of Engines—Best Point of Compression—Speed—Locomotive—Topics—Problems.	

CHAPTER VI

MULTIPLE EXPANSION ENGINES	240
Action—Combined Cards—Computation of Cards for Construction—Equivalent Work done by One Cylinder—Determination of Relative Sizes of Cylinders—Jacketing—Reheaters—Governing—Bleeding Engines or Turbines—Regenerative Engines—Testing and Analysis—Binary Engines—Topics—Problems.	

CHAPTER VII

STEAM NOZZLES, INJECTORS, STEAM TURBINES	PAGE 265
Nozzles—Injectors—Steam Nozzle Velocity—Water Velocities—Theory of the Injector—Heat Equation of the Injector—Steam Weight—Steam Nozzle—Combining Tube—Delivery Tube—Density—Impact Coefficient—Injector Details—Steam Turbines—Action of Jets—Maximum Efficiency—Types of Turbines—Efficiency—Similarity of Action of Turbine and Engine—Computations and Design—Reheat Factor—Combined Engine and Turbine—Allowance for Change of Running Conditions—Combined Engine and Turbine—Topics—Problems.	

CHAPTER VIII

CONDENSERS, COOLING TOWERS AND EVAPORATORS	333
Types of Condensers—Pressures in a Condenser—Condenser Design—Problems—Cooling Towers—Size of Tower and Mats—Spray Nozzles and Ponds—Accumulators and Evaporators—Double Bottoms—Temperature of Boiling—Topics—Problems.	

CHAPTER IX

INTERNAL COMBUSTION ENGINES AND COMBUSTION	359
Development of Engine—Otto Cycle—Air Standard Efficiency—Atkinson Cycle and Diesel Cycle—Actual Engines—Governing—Ignition—Heat Transfer to Walls—Fuels—Combustion of Fuels—Gas Composition—Problem—Temperatures at Corners of Card—Adiabatics—Efficiency Change—Temperature after Explosion—Temperature Entropy Diagram—Logarithmic Diagram—Test of Gas Engine—Combustion of Fuels for Boilers—Surface Combustion—Topics—Problems.	

CHAPTER X

REFRIGERATION	411
Air Machines—Problem—Effect of Clearance and Friction Moisture—Vapor Refrigerating Machines—Effect of Substances—Absorption Apparatus—Properties of Aqua Ammonia—Investigation of Absorption Apparatus—Topics—Problems.	

INDEX	455
-----------------	-----

SYMBOLS USED IN TEXT

<i>A</i>	= $\frac{1}{J} = \frac{1}{778}$ = const. to change foot pounds to B.t.u.
<i>A</i>	= constant in Reynold's equation.
<i>a</i>	= cleanness factor Orrok's formula.
<i>a</i>	= coefficient of heat transmission at surface.
<i>a</i>	= coefficient in various equations or length of line.
<i>B</i>	= gas constant = $\frac{pV}{MT}$ = foot-pounds per deg. per pound.
<i>B</i>	= constant in Reynold's equation.
<i>b</i>	= constant in various equations or lengths of lines.
<i>b</i>	= fraction of volume at compression in Mark's formula.
b.h.p.	= brake horse-power.
B.t.u.	= British thermal units.
<i>C</i>	= constant in equation.
<i>c</i>	= coefficient of conduction or heat transmission.
<i>c</i>	= specific heat of water or length of line.
<i>c'</i>	= specific heat of liquid.
<i>c''</i>	= specific heat of saturated steam
<i>C_p</i>	= specific heat at constant pressure of 1 cu. ft.
<i>c_p</i>	= specific heat at constant pressure.
<i>C_v</i>	= specific heat of constant volume of 1 cu. ft.
<i>c_v</i>	= specific heat of constant volume.
<i>D</i>	= displacement of cylinder in cubic feet or length of card in inches.
<i>d</i>	= diameter of cylinder or pipe in feet (or inches).
<i>d'</i>	= hydraulic radius.
<i>d</i>	= constant in equation for air movement in heat transmission or length of line.
D.H.P.	= delivered horse-power.
<i>e</i>	= area of elementary strip in Kelvin diagram.
<i>e</i>	= fraction of steam at cut-off.
<i>e</i>	= weight of evaporation in evaporator.
<i>e</i>	= constant for material in formula for heat transmission.
<i>F</i>	= area or surface in square feet (or square inches)
<i>F</i>	= Maxwell's thermodynamic potential.
<i>f</i>	= leakage factor, diagram factor, or percentage friction.
<i>f</i>	= $\sqrt{1 - y}$ = friction factor for velocity.
<i>G</i>	= lbs. of water per minute or per pound of steam.
<i>g</i>	= acceleration of gravity.
<i>H</i>	= heat from internal friction in B.t.u.
<i>H</i>	= heat in 1 cu. ft. of gas.
<i>h</i>	= feet head.
<i>h'</i>	= lift of injector in feet.
H.P.	= horse-power.
<i>I</i>	= heat content of M lbs. of substance.

i	= heat content of 1 lb. of substance.
i.h.p.	= indicated horse-power.
J	= Joule's equivalent = 778 = constant to change B.t.u. to foot-pounds.
K	= coefficient of conduction and coefficient of various equations.
k	= ratio of c_p to c_v or coefficient of equation.
K_2	= clearance factor.
Kw	= kilowatts.
L	= stroke in feet.
l	= percentage clearance or periphery of valves.
l	= length of path or thickness of material in feet.
l_p and l_v	= latent heats.
M	= mass of substance in pounds.
m	= mass of 1 cu. ft. of substance in pounds or constant in equations.
M_a	= apparent weight of steam per card, indicated.
M_i	= apparent weight of steam per card, indicated.
m_f	= weight of steam per cubic foot of displacement.
M_m	= missing weight of steam.
M_o	= clearance steam per card.
m_o	= weight of cubic feet of steam.
$m.q.$	= missing quantity in per cent. of steam used.
M_{total}	= steam used by engine.
N	= revolutions per minute.
n	= exponent of volume terms in equations.
n	= no. of molecules.
n	= heat of expansion.
o	= heat of pressure change.
P	= total force or pressure.
P	= mean effective pressure on piston.
p	= normal pressure in pounds per square foot (pounds per square inch or millimeter of mercury).
p_m	= friction factor in pipes.
Q	= heat added to M lbs. in B.t.u.
q	= heat per pound of substance or heat of solution of aqua ammonia.
q'	= heat of liquid, at outlet, q'_o ; at inlet q'_i .
q''	= total heat in 1 lb. of saturated steam.
q'''	= total heat of 1 lb. of superheated steam.
R	= universal gas constant = 1544 ft.-lbs. per deg. per molecule.
R	= total ratio of expansion.
r	= heat of vaporization.
r	= ratio of expansion.
$\frac{1}{r}$	= cut-off.
$\frac{r}{T}$	= entropy of vaporization.
r_r	= real ratio of expansion.
$r.e.$	= residual energy.
$R.H.$	= reheat factor.
s	= stroke in feet.
s	= normal cylinder surface per cubic foot of displacement.

s'	= Entropy of 1 lb. liquid.
s''	= total entropy of 1 lb. steam.
$S_2 - S_1$	= change of entropy for M lbs. of substance.
$s_2 - s_1$	= change of entropy per pound of substance.
T	= temperature in degrees from absolute zero.
T	= temperature difference in Heck's formula.
t	= temperature from F. or C. zero.
T_{sat}	= temperature of boiling.
T_{sol}	= temperature of boiling of aqua ammonia.
U	= intrinsic energy of M lbs. of substance in foot-pounds.
u	= intrinsic energy of 1 lb. of substance.
V	= volume of M lbs. of substance in cubic feet.
v	= volume of 1 lb. of substance in cubic feet.
v'	= volume of 1 lb. of liquid.
v''	= volume of 1 lb. of dry saturated steam.
W	= work in foot-pounds for M lbs. of substance.
w	= work for 1 lb. of substance.
w	= velocity of substance in feet per second.
w_a	= actual velocity of jet in feet per second.
w_b	= velocity of blade in feet per second.
w_r	= relative velocity of jet.
$wt.$	= molecular weight.
x	= quality or dryness factor = pounds of steam per pound of mixture.
x	= per cent. of NH_3 in 1 lb. of solution.
x	= point of compression, distance moved and variable length of injector.
x''	= distance on card occupied by boiler steam.
y	= friction factor for velocity.
y	= amount of liquor to produce given change in concentration.
z	= pounds of water per pound of steam in injector.
α	= acceleration.
α	= temperature coefficient.
α	= angle of actual velocity.
β	= angle of relative velocity.
γ	= angle on $I-S$ diagram.
δ	= angle on $I-S$ diagram.
Δ	= relative density in injector.
Δt	= temperature difference.
ϵ	= base of natural logarithms.
η	= efficiency or over-all efficiency.
η_1	= Carnot efficiency.
η_2	= type efficiency.
η_3	= theoretical efficiency.
η_4	= practical efficiency.
η_5	= actual efficiency.
η_6	= mechanical efficiency.
η_e	= electrical efficiency.
η_k	= kinetic efficiency.

η_m	= mechanical efficiency.
η_n	= nozzle efficiency.
η_r	= refrigerative efficiency.
η_s	= efficiency of stage.
η_t	= over-all efficiency.
η_w	= efficiency of weight.
θ	= temperature of material.
λ	= coefficient of conduction of gas.
μ	= materials factor in Orrok's formula.
ρ	= internal heat of vaporization.
ρ	= relative humidity.
ρ	= steam richness factor in Orrok's formula.
ϕ	= Maxwell's thermodynamic potential.
ϕ	= coefficient in Nicolson's formula of heat transmission.
ψ	= external work in making steam.

HEAT ENGINEERING

CHAPTER I

FUNDAMENTAL THERMODYNAMICS

Heat is a form of energy and as such it may be measured in any unit of energy. The customary unit is the **British thermal unit, B.t.u.**, although heat may be measured in **foot-pounds, ergs, joules, calories, horse-power hours, kilowatt hours** or any other unit of energy. The **B.t.u.** is $\frac{1}{180}$ of the amount of heat necessary to raise the temperature of 1 lb. of water from 32° F. to 212° F.

Heat energy is a form of energy due to a vibration or motion of the molecules of a body. It may be produced by the transformation of other forms of energy into heat, as when mechanical energy of a moving train is changed into heat by brakes. When other forms of energy are produced from heat energy, however, it is found that only a portion of the heat energy may be transformed. This leads at once to the separation of energy into two classes: **high-grade energy** and **low-grade energy**. High-grade energy is any kind of energy which may be completely changed into any other form. Mechanical and electrical energy are examples of this while heat energy is low grade since it cannot be changed completely into any other form of energy. For this reason all of the heat energy in a body is not available for transformation. The fractional part of the heat energy which is available for transformation into another form is known as the **availability** of heat energy. If Q heat units are in a system and if part of these are changed into another form of energy and Q' heat units remain in the system, then $Q - Q'$ heat units must have been changed. If this is all that could have been changed, $\frac{Q - Q'}{Q}$ represents the fractional part or the availability. It has been shown by Joule and others that when mechanical work is changed into heat or when heat is partially changed into mechanical energy there is a definite relation between the work and the

heat in the first case and between the disappearance of heat and the work produced thereby in the second case. This statement is known as the **first law of thermodynamics**. The numerical relation between heat and work is known as **Joule's equivalent**, J . It is equal to 778 ft.-lbs.

$$1 \text{ B.t.u.} = 778 \text{ ft.-lbs.} \quad (1)$$

$$JQ = W \quad (2)$$

For convenience the reciprocal of J is used at times, the symbol for this being A .

$$\frac{1}{J} = A \quad (3)$$

$$Q = AW \quad (4)$$

$$Q = \text{Heat in B.t.u.} \quad W = \text{Work in ft.-lbs.}$$

In French units the value of J is 426 kg. m. = 1 kg. deg. calorie.

Now when heat is added to a body it may increase the **internal energy** of that body and do **external work** or

$$JdQ = dU + dW \quad (5)$$

This formula is a mathematical statement of the first law of thermodynamics which is only one aspect of the law of the **conservation of energy**; heat added to a body increases the energy of that body and does external work. U is the symbol used to indicate **internal energy** or **intrinsic energy** of a body. The capital letters Q , U , W , refer to a body of any weight. If a body of unit weight is considered, small letters are used.

$$Jdq = du + dw \quad (6)$$

Now in the above equation any one of the differential quantities may be zero or have any sign. Thus if $dq = 0$, no heat is added and such action is known as **adiabatic action**. If $du = 0$, there is no change in intrinsic energy and the action is known as **isodynamic action**, while if $dw = 0$, no external work is done, and, as will be seen later, there is no change in volume. The signs of these terms may be anything and the equation is true. This equation is one of the important ones in thermodynamics. If at any time the change of intrinsic energy is known on any path or during any change of state and if the work is known during that change, then the sum of these two will be the heat required during this change. If positive, heat must be added; if negative, heat must be abstracted.

Now p represents the pressure on unit area (1 sq. ft.) of the surface of the body considered and it is assumed uniform and normal to the surface surrounding the body. If then the total area of the surface of the body is F , pF is the total normal force on the body. If this surface is moved through the normal distance dx , the work done is

$$pFdx = dW$$

but since

$$\begin{aligned} Fdx &= dV \\ pdV &= dW \end{aligned} \tag{7}$$

or

$$pdv = dw$$

The equation (6) may therefore be written

$$Jdq = du + pdv \tag{8}$$

In this equation du must be measured in the same units as pdv , namely foot-pounds, and dq on account of the constant J must be measured in heat units. The total heat is the integral of dq or

$$J \int_a^b dq = \int_a^b du + \int_a^b pdv$$

The internal energy of a body depends on the condition of the body and not on the method of bringing it to that state and consequently the change in intrinsic energy, which is $\int du$, does not depend on the manner in which one state is changed to the other but merely on the states at the beginning and the end of the operation. Hence, if the intrinsic energy at state a is u_a and at state b is u_b , the value of the integral du between these two states is $u_b - u_a$. This is true whatever the path may be.

$\int_a^b pdv$ represents the area beneath a curve on the pv plane and this area depends on the path considered. Hence the value of this integral can only be told after the curve or path is known. The integral of dq depends therefore on the path since, although $\int du$ is independent of the path, $\int dw$ or $\int pdv$ does depend on the path. A differential whose integral does not depend on the path is called an **exact differential** because it can be inte-

grated directly. Hence there must be some functional relation between the independent variables in regard to which it is being integrated, otherwise a path would have to be fixed or some relation would have to be known to give one variable in terms of the other to make the integration possible. Thus

$$\int ydx = \int dX$$

is not an exact differential since there must be some known relation between y and x before the integration can be performed.

$$\text{Now } \int dx = x \text{ and } \int (xdy + ydx) = xy$$

are each directly integrable and their definite integral values depend only on the limits and not on the path between the limits and for this reason each quantity behind the integral sign is an exact differential. It is seen that if exact differentials be integrated around a closed path their value would be zero since both limits are the same. This is one way of telling whether or not a differential is exact. If the integral on every closed path is zero, the differential is exact. There is one other criterion by which an exact differential may be told or a relation which must exist if a differential is exact, and if known to be a function of two independent variables. Thus if

$$dX = Mdx + Ndy$$

dX is an exact differential if

$$\frac{\delta M}{\delta y} = \frac{\delta N}{\delta x} \quad (9)$$

If however dX is known to be exact by some other method, then

$$\frac{\delta M}{\delta y} \text{ must equal } \frac{\delta N}{\delta x} \quad (9')$$

The reason for this is seen from the fact that if dX is exact there must be some functional relation

$$X = f(xy)$$

hence

$$dX = \frac{\delta X}{\delta x} dx + \frac{\delta X}{\delta y} dy$$

now

$$\frac{\delta X}{\delta x} = M \text{ and } \frac{\delta X}{\delta y} = N$$

but

$$\frac{\delta^2 X}{\delta x \delta y} = \frac{\delta^2 X}{\delta y \delta x}$$

hence

$$\frac{\delta^2 X}{\delta x \delta y} = \frac{\delta M}{\delta y} = \frac{\delta^2 X}{\delta y \delta x} = \frac{\delta N}{\delta x}$$

This relation between the differential coefficients M and N may be used to determine whether or not the differential is exact, or if known to be exact, the equality of the partial derivative of M and N may be used to determine new relations as will be seen later.

The fundamental equation may be written

$$Jq = u_b - u_a + \int_a^b p dv \quad (10)$$

If $q = 0$, the line is an **adiabatic** and

$$u_a - u_b = \int_a^b p dv \quad (11)$$

This means that work during an adiabatic change is equal to the change of intrinsic energy, or work is done at the expense of intrinsic energy. If $ab \infty$,

Fig. 1, represents an adiabatic path of a substance on the pv plane, the area $lab2$ represents the change of intrinsic energy from a to b . If this is carried out to infinity there can be no further area under the curve and the area from a to this point must represent the total intrinsic energy at a since no heat has been added and

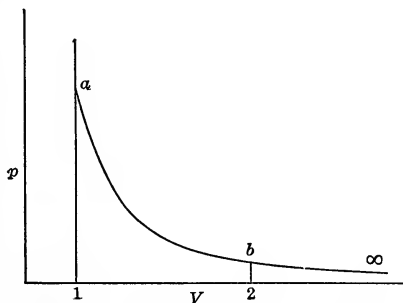

FIG. 1.—Adiabatic on the pV plane.

work has been done to the point of zero temperature. Although this area is infinite in extent it is not infinite in value since the amount of energy in a body cannot be infinite. This is seen to be true mathematically since the curve approaches the v axis rap-

idly and the height of the curve is practically zero after a short distance to the right.

If u does not change on the curve (the **isodynamic**) the heat added is equal to the work done.

$$Jq = \int_a^b pdv \quad (12)$$

If there is no work, $\int pdv = 0$, or $dv = 0$, and $v = \text{constant}$.

In this case

$$Jq = u_b - u_a \quad (13)$$

GRAPHICAL REPRESENTATION OF HEAT ON P.V. PLANE

In Fig. 2 let ab be any path. Draw from a and b two adiabatics to infinity and from a draw the isodynamic until it strikes the adiabatic from b at c .

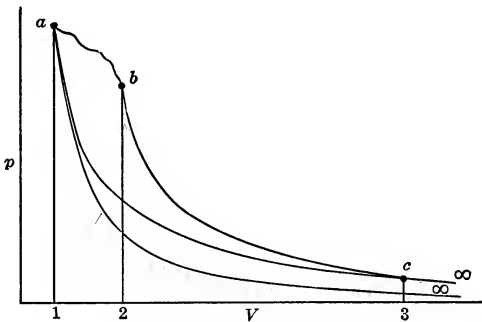

FIG. 2.—Graphical representation of heat added.

Now $1a\infty = u_a$

$2b\infty = u_b$

$1ab2 = \int_a^b pdv$

$2b\infty + 1ab2 = 1ab\infty = u_b + \int_a^b pdv$

$1ab\infty - 1a\infty = \infty ab\infty = u_b + \int_a^b pdv - u_a =$

$u_b - u_a + \int_a^b pdv = Jq$

This gives the important relation that the area on the pv plane between any path and the two adiabatics from the extremities of the path to infinity is equal to the **heat added on the path.**

This area is infinite in extent and consequently cannot be represented graphically. To make it finite and definite, the isodynamic ac was drawn. Now $u_a = u_c$. Hence $3c\infty = 1a\infty$ and

$$1ab\infty - 3c\infty = Jq = 1abc3$$

or the area beneath any path added to that beneath an adiabatic from the second point of that path to the intersection of the adiabatic and the isodynamic from the first point is equal to the heat added on the path. It will be seen that

$$1ab2 = \int_a^b pdv$$

and

$$2bc3 = u_b - u_c = u_b - u_a$$

This latter statement should be clear since $u_c = u_a$.

SCALE OF TEMPERATURE

When heat is added to a body this body comes into a state in which it will transmit heat to another body with which it had been previously in contact. This ability to transmit heat to another body is determined by a property which is termed temperature. The temperature is measured by allowing an instrument to come into thermal equilibrium with the body and then noting the effect on the instrument. If one body is at a higher temperature than another it will transmit heat to that body.

Suppose ab becomes a line of constant temperature T , such a line is called an **isothermal** (Fig. 3). If $a\infty$ and $b\infty$ are adiabatics, the area $\infty ab\infty$ is the heat added on this line ab and is finite in value since it is equal to $1ab2 + 2b\infty - 1a\infty$ and each of these is finite. If q_{ab} is divided by T the result

$$\frac{q}{T} \text{ may be called } e.$$

If the isothermal $a'b'$ is drawn below ab so that the area $abb'a'$ is equal to e and then a second isothermal $a''b''$ is so placed that $a'b'b''a''$ is equal to e and this is continued, it is found that there

will be T such isothermals drawn. Each isothermal is so drawn that the small areas are equal and these isothermals determine definite temperatures. These temperatures form a scale and since this results from considerations of absolute units of work and does not depend on any particular substance it is called the **Kelvin absolute scale of temperature**.

The ordinary scale of temperature was first determined by the effects of heat on mercury or other fluids but on account of changes in the rate of expansion of these fluids by which the temperatures were measured, gases were suggested as the media for measurement and hydrogen was found to be the most constant for all measurements. There are two scales in common use in this country, the **Fahrenheit** in which the temperature of melting ice is 32° and that of boiling water under standard conditions is

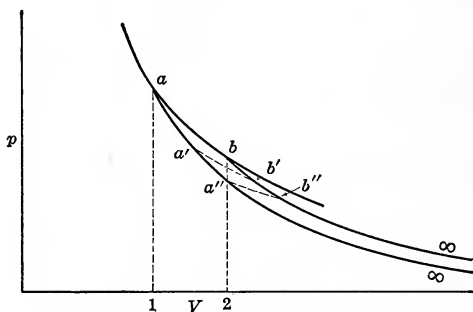

FIG. 3.—Isothermals for Kelvin's Scale.

212° , and the **Centigrade** scale on which the temperature of melting ice under standard conditions is 0° and that of boiling water under standard conditions is 100° . Neither of these start at the true **zero of temperature**. In Centigrade units the true or absolute zero is at -273° C. and in Fahrenheit units the zero is at -459.6° F. The relative size of degrees in the two systems is given by

$$1^\circ C = \frac{9}{5}^\circ F$$

It will be shown that **Kelvin's Absolute Scale** is the same as that determined by the **hydrogen thermometer**.

In looking at the diagram from which the Kelvin scale is fixed it will be seen that the area beneath any of the isothermals and the adiabatics is equal to the heat on the line and that these areas are equal to T times the unit area e . Hence the

heat added on any isothermal between points of intersection with two adiabatics is proportional to the temperature on that isothermal. This is an important consideration.

$$Q = eT \tag{14}$$

is the expression for the heat added on an isothermal of temperature T between two adiabatics and

$$Q' = eT'$$

is true at temperature T' between the same two adiabatics. This leads to the efficiency of the **Carnot cycle**.

CARNOT CYCLE

Carnot proposed a cycle made up of isothermal and adiabatic lines in a peculiar form of engine. Imagine a perfect **non-conducting cylinder** with a perfectly **conducting head** containing a **non-conducting piston** together with two bodies S and R of infinite

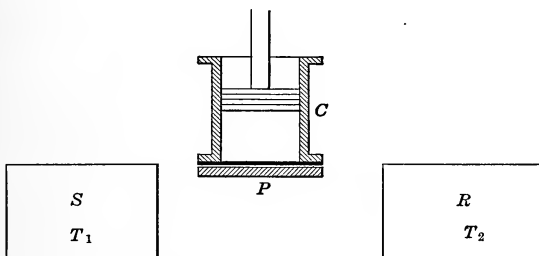

FIG. 4.—Carnot engine.

capacity for heat and a non-conducting plate P (Fig. 4). The fact that S and R are of infinite capacity means that if a finite amount of heat is added or taken away from them their temperatures will not change. The body S being at a higher temperature, T_1 , than that of the body R at T_2 , is known as the **source** while R is called the **refrigerator**.

If now the cylinder C is placed on the body S and the pressure on the piston rod is made a differential amount less than that exerted by the substance within the cylinder on the piston, the piston will be driven upward. This would mean that work is done by the substance within the cylinder and this would immediately cause its temperature to fall. On account of the

perfect conductor forming the head of the cylinder, heat will flow at once into the substance and keep its temperature constant, so that if this operation is allowed to go on, a certain amount of external work would be done, a certain amount of heat would be abstracted from S and the substance in the cylinder would be left in a given condition. If the pressure on the piston rod in this second condition is kept at a differential amount above the pressure exerted on the piston by the substance, the piston will move downward compressing the substance within and thus doing work upon it, which tends to increase the temperature causing a flow of heat into S the temperature of which cannot change. After the starting point is reached the substance within the cylinder is in its original condition with a restitution of the heat taken from S and the development of the first external work on the substance within. These two actions out and back are isothermal and because (a) they can be imagined to take place in either direction, with (b) external conditions differing by an infinitesimal quantity and because (c) all things external and internal can be restored to the initial conditions by coming back over the path to the original condition by a reversal of directions; such action is known as **reversible action**. These three **conditions** must hold for all **reversible actions**.

If instead of returning to the original condition after the addition of Q_1 heat units from S , the cylinder is slipped to the non-conducting plate and then the substance within the cylinder is allowed to expand by causing the pressure on the rod to be a differential amount less than the pressure on the piston, the substance within can receive no heat and the expansion will be **adiabatic**. The external work will be done at the expense of or by the intrinsic energy in the substance. Of course the temperature within the body must fall and when this reaches the temperature of R , (T_2), the operation is stopped and the cylinder is put into communication with R .

If before the cylinder is put into communication, the force on the piston rod is increased an infinitesimal amount, the substance within the cylinder will be compressed by external energy applied and this operation will be adiabatic, taking place in the reverse direction over the same path. It is seen that this fulfills the three conditions mentioned above and hence the **adiabatic line** is **reversible**.

When the cylinder is connected with R and the force on the rod is increased by a differential amount, the substance within is compressed. This tends to increase the temperature which causes a flow through the perfect conductor into the body of infinite capacity. This causes **reversible isothermal compression**. Suppose that this is continued until Q_2 heat units are abstracted to such a point that when the cylinder is removed to P and adiabatic compression to the temperature T_1 occurs, it will be in its original condition. This is shown on the pv plane by Fig.

5. In this 1-2 is an isothermal of temperature T_1 on which Q_1 heat units have been added. Point 2 is arbitrary. 2-3 is an adiabatic on which no heat has been added. The point 3 is fixed by its temperature T_2 at which the adiabatic expansion must stop. 3-4 is an isothermal of temperature T_2 on which Q_2 heat units have been abstracted and on which the point 4 is fixed so that the adiabatic 4-1 on which no heat is added will end at the original point 1. This is known as the **Carnot cycle**.

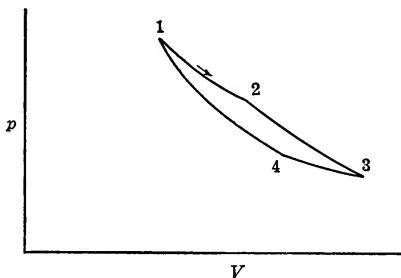

FIG. 5.—Carnot cycle.

5. In this 1-2 is an isothermal of temperature T_1 on which Q_1 heat units have been added. Point 2 is arbitrary. 2-3 is an adiabatic on which no heat has been added. The point 3 is fixed by its temperature T_2 at which the adiabatic expansion must stop. 3-4 is an isothermal of temperature T_2 on which Q_2 heat units have been abstracted and on which the point 4 is fixed so that the adiabatic 4-1 on which no heat is added will end at the original point 1. This is known as the **Carnot cycle**.

REVERSED CYCLE

There is no reason why these operations could not occur in the reverse direction. In this case Q_2 heat units would be taken from R and Q_1 heat units would be given up to S .

Consider the path 1, 2, 3, 4, 1 on which the total heat added is

$$Q_1 + 0 - Q_2 + 0 = Q_1 - Q_2$$

but

$$Q = U_b - U_a + AW$$

and on the closed path

$$U_b = U_a$$

since the operation is brought back to the original point.

Hence

$$Q_1 - Q_2 = AW$$

If this takes place in the opposite direction

$$Q_2 - Q_1 = - AW$$

or work AW must be done from the outside so that Q_1 heat units may be discharged into the source when a smaller quantity Q_2 has been added from the refrigerator.

Of course these must be so since if the substance within the cylinder has been brought back to its original condition and Q_1 heat units have been added while Q_2 have been abstracted, the difference $Q_1 - Q_2$ must have gone into external work. In any case since

$$\begin{aligned} J \int dQ &= U_2 - U_1 + \int dW \\ J \int dQ &= \int dW \end{aligned} \quad (15)$$

if $U_2 - U_1 = 0$. In any **closed cycle** (a path ending at the point from which it starts) the algebraic sum of the heats on all paths of the cycle is equal to the work done. This is regardless of the reversibility of the path.

The heat supplied on any cycle is Q_1 and hence its **efficiency** is

$$\frac{AW}{Q_1} = \frac{Q_1 - Q_2}{Q_1} = \text{Eff.} \quad (16)$$

For the Carnot cycle this may be simplified, since the heat transfers are on isothermals limited by the same two adiabatics. In this case

$$\begin{aligned} Q_1 &= eT_1 && [\text{See Eq.(14)}] \\ Q_2 &= eT_2 \\ \therefore \text{Eff.} &= \frac{e(T_1 - T_2)}{eT_1} = \frac{T_1 - T_2}{T_1}. \end{aligned} \quad (17)$$

This is the value of the **efficiency of the Carnot cycle** and it is the expression for availability as will be seen later. Hence between the limits T_1 and T_2 , heat has an availability $\frac{T_1 - T_2}{T_1}$ if used on a Carnot cycle.

MAXIMUM EFFICIENCY

Suppose there is a cycle of efficiency greater than that of the Carnot cycle. Call this cycle, cycle r . If there is a source and a refrigerator of temperatures T_1 and T_2 , the Carnot cycle and other cycle may be operated between these, and the efficiencies will give the inequality

$$\frac{Q_{1c} - Q_{2c}}{Q_{1c}} < \frac{Q_{1r} - Q_{2r}}{Q_{1r}}$$

Suppose these two engines be connected to the same shaft and the efficient engine be used as the driver to drive the Carnot engine in a reversed direction. In this case Q_{1r} will be taken from S and Q_{1c} will be given to the source. Neglecting friction the work required by one will just equal the work developed by the other.

$$Q_{1c} - Q_{2c} = Q_{1r} - Q_{2r}$$

Since the inequality is true

$$Q_{1c} > Q_{1r}$$

or more heat is being added to the source than is taken from it. Since the two engines coupled to the source and refrigerator receive no energy or give no energy to the outside (one drives the other) the heat going to the source must come from the refrigerator, and there exists something with no connection with outside systems which causes heat to flow from a point of low temperature to a point of higher temperature when placed between the two points. This is unthinkable from all experience, hence Q_{1c} cannot be greater than Q_{1r} and the efficiency of the cycle cannot be greater than that of the Carnot cycle. Hence the Carnot cycle is as efficient as any cycle.

Suppose now the cycle is reversible, in which case the Carnot cycle might be used as the driver if of greater efficiency than that of the other cycle.

$$\frac{Q_{1c} - Q_{2c}}{Q_{1c}} > \frac{Q_{1r} - Q_{2r}}{Q_{1r}}$$

$$Q_{1c} - Q_{2c} = Q_{1r} - Q_{2r}$$

$$Q_{1r} > Q_{1c}$$

Or the amount received by the source from the reversed cycle is greater than that taken by the direct Carnot engine. This cannot be so and hence a Carnot cycle cannot have a greater efficiency than that of the reversible cycle. But none can be greater than the Carnot.

Since the efficiency of the cycle r cannot be greater and cannot be less than that of the Carnot cycle it must be equal to it and hence all reversible cycles have the same efficiency, which is equal to that of the Carnot cycle. All that can be said of non-reversible cycles is that they cannot have greater efficiencies than that of the Carnot cycle.

This proof can be used to show that the efficiency is independent of the medium used, for if one substance gave a higher efficiency it could be used on a Carnot cycle as a driver while the other substance would be used as the medium of a reversed Carnot cycle. The reasoning would lead to the same absurd result and hence all substances will give the same efficiency theoretically when operating between the same source and refrigerator.

The Carnot efficiency is the maximum efficiency and if the limiting temperatures are T_1 and T_2

$$\frac{T_1 - T_2}{T_1} \text{ or } 1 - \frac{T_2}{T_1}$$

is the maximum availability. Being the maximum it is that which should be obtained in practice theoretically and hence it is called simply the **availability**.

CONDITIONS FOR AVAILABILITY OF HEAT

This leads to the observation that the only way in which heat can be available is to have a difference in temperature necessitating two bodies at different temperatures and a substance which can receive and discharge the heat. The three systems are necessary to make heat available.

Of Q_1 heat units only $\left(\frac{T_1 - T_2}{T_1}\right)Q_1$ are available for useful work and $Q_1\frac{T_2}{T_1}$ must be rejected. Of course this rejected heat or wasted heat so far as the work AW is concerned may be used for some valuable purpose, as when it is rejected from a steam engine and used for warming buildings or for heating water for a wash house.

This leads to the **Second Law of Thermodynamics:**

SECOND LAW

“It is impossible by means of a self-acting machine unaided by any external agency to convey heat from one body to another at higher temperature” or “no change in a system of bodies that can take place of itself can increase the available energy of the system.” When the matter is discussed in the manner given above, this law results in the expression

$$\frac{T_1 - T_2}{T_1} = \text{Availability or Carnot Efficiency,}$$

$$dS = \frac{dQ}{T} + \frac{dH}{T}$$

is the conclusion from this law when the gain in unavailable energy is considered, as will be seen later. Each of the above expressions results from the second law of thermodynamics.

Having seen two **paths** which are **reversible**; the **isothermal** and the **adiabatic**, it may be well to consider some changes which are **irreversible** and for that reason cannot truly be represented on the pv plane.

LOSS OF AVAILABILITY

Suppose heat flows by conduction from one body of high temperature to one of low temperature. Such action cannot possibly be assumed to take place in the reversed direction and therefore on account of the first requirement it is non-reversible.

If a gas is assumed to discharge freely from a vessel of pressure p_1 to a place of distinctly lower pressure p_2 , such action could not be assumed to take place in an opposite manner, and lastly if work be changed into heat as by friction this could not be assumed to take place in a reverse direction.

In all of these there is a loss of availability.

In the first the loss of available heat would be the difference of the available heats at the two temperatures. This is

$$Q_1 \left(1 - \frac{T_0}{T_1} \right) - Q_1 \left(1 - \frac{T_0}{T_2} \right) = T_0 \left[\frac{Q_1}{T_2} - \frac{Q_1}{T_1} \right]$$

if T_0 is the lowest possible temperature, and T_1 and T_2 are the temperatures of the two sides of the conducting surface.

In the second case the pressure has been brought nearer to the pressure of the surrounding medium and hence by the time it is brought to this pressure by adiabatic expansion the temperature will not be so low as it could have been before. Hence

$$Q_1 \left[1 - \frac{T_0}{T_1} \right] > Q_1 \left[1 - \frac{T_0'}{T_1'} \right]$$

Since

$$T_0 < T_0'$$

T_1 is almost equal to T_1'

$$\text{Loss in available heat} = T_0 \frac{Q}{T_1} - T_0' \frac{Q}{T_1}$$

In the third case if AW units of work are changed into heat of temperature T_1 the available part of this is

$$AW \left(1 - \frac{T_0}{T_1} \right) \text{ or } Q \left(1 - \frac{T_0}{T_1} \right)$$

All of it was available as mechanical energy before the change, hence

$$T_0 \frac{Q}{T_1}$$

represents the loss of available energy.

In the reversible changes or on the reversible cycles the un-available energy before the operation was

$$Q_1 \frac{T_0}{T_1}$$

and this is the amount rejected by the reversible cycle. Hence in this case there is no increase of unavailable energy.

ENTROPY

Goodenough points out that in all of these cases the non-reversible changes have brought about a loss of available energy and that these expressions are all of the form

$$T_0 \left(\frac{Q_1}{T_1} \right)$$

He then says that the quantity which when multiplied by T_0 , the lowest available temperature, gives the increase of un-available energy due to a non-reversible or other change is called the **increase of entropy**.

This quantity is of the form $\frac{Q}{T}$ and refers to one system or to several systems. If one system alone is considered there may be an increase or decrease of entropy due to the change of heat, while if two systems are considered reversible changes lead to no change in unavailable energy and hence no change of entropy, while non-reversible changes lead to an increase of un-available energy and consequently an increase of entropy. Thus if the source alone is considered when Q_1 heat units are given up to the cylinder of the Carnot engine, there is an un-available amount of heat $T_0 \frac{Q_1}{T_1}$ taken from this source and given to the medium in the cylinder. There is a decrease of entropy of $\frac{Q_1}{T_1}$ for the source but that of the medium is increased by $\frac{Q_1}{T_1}$ and the sum of these two is zero. This is true if the cycle

is worked in the reverse direction. If there is conduction of heat the loss of entropy will be $\frac{Q_1}{T_1}$, while the gain of entropy will be $\frac{Q_1}{T_2}$. This latter is greater since T_2 is less than T_1 . Hence there is a gain in entropy

$$\frac{Q_1}{T_2} - \frac{Q_1}{T_1}$$

when the irreversible change takes place. This is the only direction in which this operation can take place, while in reversible action the operation may take place in either direction. Hence if all bodies or systems taking place in a change be considered together, a process which will take place of itself will be accompanied by an increase of entropy. If there is no change in the entropy the change will take place in either direction.

Goodenough shows further that only one part of a system may be considered and then the increase of unavailable energy

$$T_0 \frac{Q}{T_1} \text{ or } T_0 \int \frac{dQ}{T}$$

may be accomplished by adding heat Q or if the temperature T_1 is not constant by adding $\int dQ$. Since this heat may come from internal friction, as well as from the outside, and the symbol Q refers to heat added, H will be used for the heat developed by internal friction. In this case then

$$\text{Entropy change} = \int \frac{dQ}{T} + \int \frac{dH}{T}$$

There could be a loss of availability and consequently an increase of entropy if there was internal conduction, but this need not be considered as in most problems the system is assumed at a uniform temperature throughout and any change in one part is the same in all parts. If S be assumed for the symbol of entropy

$$\int dS = \int \frac{dQ}{T} + \int \frac{dH}{T}$$

Since the amount of unavailable energy is dependent on the energy in a body and its temperature, the entropy, which is the unavailable energy divided by the lowest possible tem-

perature, is also dependent on these. Hence entropy depends on the state of a body and dS must be an exact differential, giving

$$S_2 - S_1 = \int_{T_1}^{T_2} \frac{dQ}{T} + \int_{T_1}^{T_2} \frac{dH}{T} \quad (18)$$

ENTROPY AROUND A CYCLE

Now dH is the heat of internal friction and is positive in all cases. Hence although around a closed cycle $\int dS = 0$, since a return is made to the original point, $\int \frac{dH}{T}$ must always be positive and therefore in such a case $\int \frac{dQ}{T}$ must be a negative quantity. When there is internal friction $\int \frac{dQ}{T}$ is negative around a closed cycle. If, however, $dH = 0$ there is no friction and

$$\int \frac{dQ}{T} = 0 \quad (19)$$

around a closed cycle. This friction when it exists always acts to produce heat no matter in what direction one progresses along a path. It is this which makes a theoretical path of any form on the pv plane an irreversible path. Hence the following statements are made:

$$S_2 - S_1 = 0$$

on any closed cycle.

$$S_2 - S_1 = \int \frac{dQ}{T} = 0$$

on a closed reversible cycle.

$$S_2 - S_1 = 0 > \int \frac{dQ}{T} \quad (20)$$

on a closed irreversible cycle (internal friction present).

Now

$$dS = \frac{dQ}{T} + \frac{dH}{T}$$

or

$$\int TdS = \int dQ + \int dH$$

ENTROPY DIAGRAM

$\int TdS$ is an area between a curve of coordinates T and S and the axis of entropy and it must equal the heat added from the outside if $dH = 0$ or the line is reversible and if dH does not equal zero it represents the heat added from the outside, plus the heat added by friction.

With these coordinates, lines of constant temperature become parallel to the S axis or horizontal while lines of constant entropy are vertical lines. The areas beneath any line represent the heat added from the outside plus the internal friction. If there is no friction (the line is reversible), area beneath the line represents the heat added from the outside. If the lines are reversible the line of constant entropy must be an adiabetic since

$$dS = \int \frac{dQ}{T} = 0$$

and because T does not equal infinity, dQ must equal zero. This is the condition for an adiabetic. If the lines are adiabetic lines with internal friction the entropy increases due to this friction and hence the lines must progress to the left.

CHARACTERISTIC EQUATIONS

A substance of unit weight under a definite hydrostatic pressure and at a given temperature will occupy a certain volume and if the pressure and temperature change, the volume will change. In most cases there is for every substance a functional relation between these three properties or

$$\phi(p, v, t,) = 0 \quad (21)$$

This is called the **characteristic equation** of the substance and for each substance there is assumed to be such an equation determined by experiment. This equation being between three coordinates is the equation of a surface.

The equations for some of the well-known substances used in heat engines are as follows:

For perfect gases

$$pv = BT \text{ or} \quad (22)$$

$$pV = MBT \quad (23)$$

For saturated steam

$$\log p = \log k - n \log \frac{T}{T - b} \quad (24)$$

For saturated vapors

$$\log p = a + b\alpha^n + c\beta^n \quad (25)$$

where $n = (t - t_0)$

For superheated steam

$$v + c = \frac{BT}{p} - (1 + ap) \frac{m}{T^n} \quad (26)$$

For other superheated vapors

$$pv = BT - cp^n \quad (27)$$

HEAT ON A PATH

Now to study any path on which heat is added the **path** on the surface represented by the characteristic equation could be

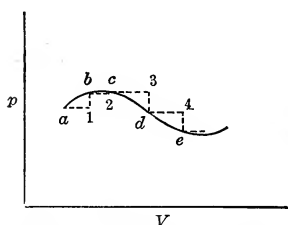

FIG. 6.—Path on the pV plane.

projected on any one of the **three planes**, pv , pt or vt . The first one of these is the best since area beneath the path represents external work but further than this there is no reason for its use. Suppose for instance the path is shown in Fig. 6. To find the heat the path is changed to the broken path of constant pressure and constant volume lines of differential length as shown.

The heat to change the volume by unit amount on the constant pressure line is $\left(\frac{\delta Q}{\delta v}\right)_p$ and the amount to change the pressure by

unity on a constant volume line is $\left(\frac{\delta Q}{\delta p}\right)_v$. In the broken path the change from a to 1 is dv and that from 1 to b is dp . These quantities are arbitrary in amount if the path is not fixed and hence they are **independent variables**. The heat added on a path is

$$dQ = \left(\frac{\delta Q}{\delta v}\right)_p dv + \left(\frac{\delta Q}{\delta p}\right)_v dp \quad (28)$$

It must be remembered that for a definite path **only one** of these is an **independent variable** since the **path** necessitates a **relation** between the two variables.

In the same manner, if the path is projected on the plane pt , or vt , the expressions would be

$$dQ = \left(\frac{\delta Q}{\delta t}\right)_v dt + \left(\frac{\delta Q}{\delta v}\right)_t dv \quad (29)$$

or

$$dQ = \left(\frac{\delta Q}{\delta t}\right)_p dt + \left(\frac{\delta Q}{\delta p}\right)_t dp \quad (30)$$

If a pound of substance is referred to, these may be written with small letters.

The equations are the **fundamental differential equations of heat**.

The quantities $\left(\frac{\delta q}{\delta t}\right)$, etc., which represent the amount of heat added to 1 lb. of substance to change one of the properties, p , v , or t , by unity when another property, p , v , or t , remains constant, are known as **thermal capacities**. Since these are expressed in heat units which refer to water their values have the definite names given below

$$\left(\frac{\delta q}{\delta t}\right)_v = c_v, \text{ specific heat at constant volume.}$$

$$\left(\frac{\delta q}{\delta t}\right)_p = c_p, \text{ specific heat at constant pressure.}$$

These are the amounts of heat to change the temperature of unit weight by one degree when either the volume or pressure is constant.

$$\left(\frac{\delta q}{\delta v}\right)_t = l_v, \text{ latent heat of expansion.}$$

This is the amount of heat added to 1 lb. of substance at constant temperature to change the volume by unity. It is **latent** because the temperature does not change.

$$\left(\frac{\delta q}{\delta p}\right)_t = l_p, \text{ latent heat of pressure change.}$$

$$\left(\frac{\delta q}{\delta v}\right)_p = n, \text{ heat of expansion at constant pressure.}$$

$$\left(\frac{\delta q}{\delta p}\right)_v = o, \text{ heat of pressure change at constant volume.}$$

Using these symbols the three equations may be simplified

$$dq = c_v dt + l_v dv \quad (29')$$

$$dq = c_p dt + l_p dp \quad (30')$$

$$dq = n dv + o dp \quad (28')$$

It will be remembered that dq is not an exact differential and hence there is no differential relation between the coefficients of any one of the equations. There are relations which may be made by equating any two of the equations since these are expressions for the same quantity. Hence

$$c_v dt + l_v dv = c_p dt + l_p dp \quad (31)$$

This appears to be an equation with three independent variables. There is always a characteristic equation with p , v , and t , and hence any one of these three is known in terms of the other two. Suppose t is eliminated by

$$dt = \left(\frac{\delta t}{\delta v}\right)_p dv + \left(\frac{\delta t}{\delta p}\right)_v dp$$

Hence

$$\left[c_v \left(\frac{\delta t}{\delta v}\right)_p + l_v \right] dv + c_v \left(\frac{\delta t}{\delta p}\right)_v dp = \left[c_p \left(\frac{\delta t}{\delta p}\right)_v + l_p \right] dp + c_p \left(\frac{\delta t}{\delta v}\right)_p dv$$

Now this equation is true for any value of dv and for any value of dp if a definite path is not assumed, or in other words, it is true for any path. The only way that this can be true is to have the coefficients of the same variable on each side of the equation equal. Hence

$$c_v \left(\frac{\delta t}{\delta p}\right)_v = c_p \left(\frac{\delta t}{\delta p}\right)_v + l_p$$

or

$$c_p - c_v = -l_p \left(\frac{\delta p}{\delta t}\right)_v \quad (32)$$

and

$$c_v \left(\frac{\delta t}{\delta v}\right)_p + l_v = c_p \left(\frac{\delta t}{\delta v}\right)_p dv$$

or

$$c_p - c_v = l_v \left(\frac{\delta v}{\delta t}\right)_p \quad (33)$$

Eliminating dv from (31) leads to

$$l_v \left(\frac{\delta v}{\delta p}\right)_t = l_p \quad (34)$$

and

$$c_p - c_v = l_v \left(\frac{\delta v}{\delta t}\right)_p \quad (33)$$

Eliminating dp from (31) leads to

$$l_v = l_p \left(\frac{\delta p}{\delta v} \right)_t$$

and

$$c_p - c_v = - l_p \left(\frac{\delta p}{\delta t} \right)_v$$

which have been found before. By equating (28') with either (29') or (30') other relations could be found.

$$n = c_v \left(\frac{\delta t}{\delta v} \right)_p + l_v \quad (35)$$

$$o = c_v \left(\frac{\delta t}{\delta p} \right)_v \quad (36)$$

DIFFERENTIAL EQUATIONS AND RELATIONS

Now

$$Jdq = du + pdv$$

and for reversible paths ($dH = 0$)

$$\begin{aligned} dq &= Tds \\ \therefore du &= Jdq - pdv = \frac{Tds}{A} - pdv \end{aligned} \quad (37)$$

Another quantity used throughout the theory of thermodynamics which has an important use is the **heat content**. This is not the heat contained in a body but it is that heat plus the product of the pressure and volume. This is the amount of energy which would leave with a substance when it is forced out of a region in which the pressure is kept constant. It is represented by the symbol i and defined by

$$i = A(u + pv) \quad (38)$$

$$I = Mi$$

M = weight of the substance.

It will be seen that i depends on the state of the substance since u , p , and v are all dependent on the state. It is expressed in heat units.

$$di = Adu + Apdv + Avdp$$

Substituting from (37)

$$di = Tds + Avdp \quad (39)$$

Two other quantities known as **thermodynamic potentials**, F and ϕ , are given by the equations

$$F = Au - Ts$$

$$\phi = Ai - Ts$$

These are both functions of the state, since u , T , s , and i are fixed by the state. Their differentials reduce to

$$-dF = sdT + A pdv \quad (40)$$

$$d\phi = Avdp - sdT \quad (41)$$

Now du , di , dF and $d\phi$ are all exact differentials since they depend on the state and hence, as they are expressed as functions of two variables, the partials of the coefficients of the independent variables with regard to the other independent variables are equal. Taking the equations (37), (39), (40) and (41) the following results are true:

$$\left(\frac{\delta T}{\delta v}\right)_s = A \left(\frac{\delta p}{\delta s}\right)_v \quad (42)$$

$$\left(\frac{\delta T}{\delta p}\right)_s = A \left(\frac{\delta v}{\delta s}\right)_p \quad (43)$$

$$\left(\frac{\delta s}{\delta v}\right)_T = A \left(\frac{\delta p}{\delta t}\right)_v \quad (44)$$

$$\left(\frac{\delta s}{\delta p}\right)_T = -A \left(\frac{\delta v}{\delta t}\right)_p \quad (45)$$

The four equations above are **Maxwell thermodynamic equations**.

Now

$$\frac{dq}{T} = ds$$

Hence (44) and (45) reduce to

$$\left(\frac{\delta q}{\delta v}\right)_t = AT \left(\frac{\delta p}{\delta t}\right)_v = l_v \quad (46)$$

$$\left(\frac{\delta q}{\delta p}\right)_t = -AT \left(\frac{\delta v}{\delta t}\right)_p = l_p \quad (47)$$

Substituting (46) and (47) equations (29') and (30') become

$$dq = c_v dt + AT \left(\frac{\delta p}{\delta t}\right)_v dv \quad (48)$$

$$dq = c_p dt - AT \left(\frac{\delta v}{\delta t}\right)_p dp \quad (49)$$

Substituting (36), (35), and (33) in (28') this becomes

$$\begin{aligned} dq &= \left[c_v \left(\frac{\delta t}{\delta v} \right)_p + (c_p - c_v) \left(\frac{\delta t}{\delta v} \right)_p \right] dv + c_v \left(\frac{\delta t}{\delta p} \right)_v dp \\ &= c_p \left(\frac{\delta t}{\delta v} \right)_p dv + c_v \left(\frac{\delta t}{\delta p} \right)_v dp \end{aligned} \quad (50)$$

Now

$$c_p - c_v = l_v \left(\frac{\delta v}{\delta t} \right)_p \quad (33)$$

and

$$l_v = AT \left(\frac{\delta p}{\delta t} \right)_v$$

$$\therefore c_p - c_v = AT \left(\frac{\delta v}{\delta t} \right)_p \left(\frac{\delta p}{\delta t} \right)_v \quad (51)$$

and

$$\begin{aligned} \left(\frac{\delta t}{\delta v} \right)_p &= \frac{AT \left(\frac{\delta p}{\delta t} \right)_v}{c_p - c_v} \\ \left(\frac{\delta t}{\delta p} \right)_v &= \frac{AT \left(\frac{\delta v}{\delta t} \right)_p}{c_p - c_v} \end{aligned}$$

Equation (50) becomes

$$dq = \frac{AT}{c_p - c_v} \left[c_p \left(\frac{\delta p}{\delta t} \right)_v dv + c_v \left(\frac{\delta v}{\delta t} \right)_p dp \right] \quad (52)$$

(48), (49) and (52) are in the same form since the partial derivatives are all derivatives with regard to dT .

Equation (51) is an important relation which leads to valuable results.

Goodenough derives two other equations which are of value. These follow:

$$du = Jdq - pdv$$

using (48) this becomes

$$\begin{aligned} du &= Jc_v dt + \left[T \left(\frac{\delta p}{\delta t} \right)_v - p \right] dv \\ di &= Tds + Avdp \\ &= dq + Avdp \end{aligned} \quad (53)$$

using (49) this reduces to

$$di = c_p dt - A \left[T \left(\frac{\delta v}{\delta t} \right)_p - v \right] dp \quad (54)$$

du and di are exact differentials. Hence

$$\begin{aligned}\frac{\delta}{\delta v}(Jc_v)_t &= \frac{\delta}{\delta t} \left[T \frac{\delta p}{\delta t} - p \right]_v \\ J \left(\frac{\delta c_v}{\delta v} \right)_t &= \frac{\delta p}{\delta t} + T \frac{\delta^2 p}{\delta t^2} - \frac{\delta p}{\delta t} \\ \left(\frac{\delta c_v}{\delta v} \right)_t &= AT \left(\frac{\delta^2 p}{\delta t^2} \right)_v\end{aligned}\quad (55)$$

and from (54)

$$\left(\frac{\delta c_p}{\delta p} \right)_t = -AT \left(\frac{\delta^2 v}{\delta t^2} \right)_p \quad (56)$$

These equations (55) and (56) are of value in making certain deductions.

Equations (46), (47), (48), (49), (50), (51), (52), (53), (54), (55) and (56) are important equations in the development of thermodynamics. It must be remembered that all of these are general equations and refer to any substance. The partial derivatives, such as $\left(\frac{\delta v}{\delta t} \right)_p$, are found from the characteristic equation of the substance used in any problem.

PERFECT GASES

A **perfect gas** is a substance which obeys the **law of Boyle** and the **law of Charles**. From these two laws the characteristic equation becomes

$$pv = BT \quad (57)$$

or

$$pV = MBT \quad (58)$$

p = pressure in pounds per square foot

v = volume of 1 lb. of substance in cubic feet

V = total volume of M pounds in cubic feet

M = weight in pounds

B = a constant

T = absolute temperature

= Fahr. temp. + 459.6

Now

$$B = \frac{pv}{T} = \frac{p}{mT} \quad (59)$$

m = weight of 1 cu. ft. of gas.

If for air, the weight of 1 cu. ft. is found to be 0.08071 lbs. per cubic foot at atmospheric pressure and at 32° F., B is found to be

$$B = \frac{2116.3}{0.08071 \times 491.6} = 53.34$$

By the **law of Avogadro** equal volumes of gases at the same pressure and temperature contain equal number of molecules hence, if wt = molecular weight

$$m = Kwt$$

$$\therefore B = \frac{p_0}{Kwt T_0} = \frac{\text{const.}}{wt}$$

or

$$Bwt = \text{const.} = R \tag{60}$$

R = universal gas constant.

The weight of oxygen per cubic foot under atmospheric pressure and at 32° F. is 0.089222 lbs.

$$B_{\text{oxygen}} = \frac{2116.3}{0.089222 \times 491.6} = 48.25$$

Hence

$$R = 48.25 \times 32 = 1544$$

and

$$B_{\text{gas}} = \frac{1544}{wt_{\text{gas}}} \tag{61}$$

Now the molecular weight of air is found from the fact that air contains 79 per cent. by volume of N_2 and 21 per cent. of O_2 . By Avogadro's Law, considering one molecule to each unit volume, the weight is equal to volume multiplied by the molecular weight.

$$\begin{array}{rcl} 0.79 \times 28.08 & = & 22.18 \\ 0.21 \times 32 & = & 6.72 \\ \hline \end{array}$$

$$\text{wt. of 1 vol.} = 28.90$$

Hence

$$B_{\text{air}} = \frac{1544}{28.9} = 53.4$$

The correct value of this is 53.34 showing that the molecular weight of air is 28.93.

If there is a mixture of various gases in a given volume there are two points of view to be considered: (a) all of the constituent

gases occupy the whole volume and each is under a **partial pressure** such that the sum of the pressures equals the total pressure, or (b) each gas is under the total pressure but occupies a part of the volume so that the sum of the **partial volumes** equals the total volume. The first view is known as **Dalton's Law** and represents what really takes place when a number of gases are mechanically mixed. If $p_1, p_2, p_3 \dots$ represent the partial pressures of the various gases which weigh $M_1, M_2, M_3 \dots$ and if all the gases occupy the volume V the following are true:

$$\begin{aligned}
 p &= p_1 + p_2 + p_3 \dots \text{ (Dalton's Law)} \\
 M &= M_1 + M_2 + M_3 \dots \\
 p &= M_1 B_1 \frac{T}{V} + M_2 B_2 \frac{T}{V} + \dots = \frac{T}{V} \Sigma M B \\
 p \frac{V}{T} &= M B_{mixture} = \Sigma M_1 B_1
 \end{aligned}$$

or

$$B_{mixture} = \frac{\Sigma M_1 B_1}{\Sigma M} \quad (62)$$

This is not as convenient a method as working with volumes since in most cases it is the proportional volumes which are known and not the proportional weights. By Avogadro's Law each unit of volume may be assumed to have one molecule.

$$V_1 w t_1 = \text{proportional weight.}$$

$$\Sigma V_1 w t_1 = \Sigma \text{proportional weights} = \text{total weight}$$

If this is divided by the sum of the volumes, the weight of unit volume, which by assumption is the molecular weight, is found.

Hence

$$\frac{\Sigma V_1 w t_1}{\Sigma V} = w t_{mixture} \quad (63)$$

$$B_{mixture} = \frac{1544}{w t_{mixture}} \quad (64)$$

In the above manner by (61), (63) and (64) the value of B for any gas or mixture may be found if the gas is assumed to be a perfect gas. No gas obeys the laws of Boyle and Charles completely and hence the characteristic equation

$$pV = MBT$$

is not exactly true for any gas. Under great pressures there is variation, but air, hydrogen, nitrogen, carbon monoxide, meth-

ane, ethylene, and other hydrocarbons are assumed to follow these laws. Carbon dioxide and steam do not obey the equation, but at times they are handled as if they did.

To aid in working out the values of B the following molecular weights are given:

Hydrogen	H ₂	2.016
Carbon monoxide	CO	28.0
Oxygen	O ₂	32.0
Methane	CH ₄	16.032
Ethylene	C ₂ H ₄	28.032
Nitrogen	N ₂	28.08
Carbon	C	12.0
Ammonia	NH ₃	17.064
Carbon dioxide	CO ₂	44.0
Steam	H ₂ O	18.016
Sulphur	S	32.06

DIFFERENTIAL HEAT EQUATIONS FOR PERFECT GASES

For a perfect gas

$$pv = MBT^r$$

or

$$pv = BT$$

and the various equations (46), etc., are reduced by the following:

$$\left(\frac{\delta p}{\delta t}\right)_v = \frac{B}{V}$$

$$\left(\frac{\delta v}{\delta t}\right)_p = \frac{B}{p}$$

It is to be remembered that although $t + 459.6 = T$

$$\delta t = \delta T.$$

$$l_v = \frac{ATB}{v} \tag{46}$$

$$l_p = -\frac{ATB}{p} \tag{47}$$

$$dq = c_v dt + \frac{ATB}{v} dv = c_v dt + A p dv \tag{48}$$

$$dq = c_p dt - \frac{ATB}{p} dp = c_p dt - A v dp \tag{49}$$

$$dq = c_p \frac{p}{B} dv + c_v \frac{V}{B} dp = c_p T \frac{dv}{v} + c_v T \frac{dp}{p} \tag{50}$$

$$c_p - c_v = AT \frac{B}{p} \frac{B}{v} = AB \tag{51}$$

In equation (48) the last term represents the external work, therefore the first term represents the change in intrinsic energy:

$$Jc_v dt = du \quad (65)$$

Now du is an exact differential and must be directly integrable. Hence $c_v dt$ must also be directly integrable (*i.e.*, with no reference to any path) and therefrom c_v for a **perfect gas** is a **constant** or a **function of t** .

SPECIFIC HEATS

Now experiment proves that c_v is a function of t of the form

$$c_v = a + bt$$

or

$$\begin{aligned} c_v &= a + b(T - 459.6) = a - 459.6b + bT \\ &= a' + bT \end{aligned} \quad (66)$$

But

$$\begin{aligned} c_p - c_v &= AB \\ c_p &= AB + a' + bT = a'' + bT \end{aligned} \quad (67)$$

Now since

$$c_p - c_v = AB$$

c_p , c_v , and AB must be of the same nature, if c_p and c_v are specific quantities AB must be a specific quantity. Since c_p is the amount of heat to change the temperature one degree and since $c_v dt = du$ and therefore c_v is the amount of internal energy change when the temperature changes one degree on any line, AB must be the amount of external work when the temperature changes one degree at constant pressure.

Since

$$wt \times B = R, \text{ a constant}$$

$$wt \times c_v = a^{\text{III}} + b^{\text{III}} T$$

$$wt \times c_p = a^{\text{IV}} + b^{\text{IV}} T$$

are the universal forms of specific heats and these differ by AR .

$$wt \times c_p - wt \times c_v = AR = \frac{1544}{778} = 1.9855$$

The values of the a 's and b 's are given below

$$\left. \begin{aligned} wt \times c_v &= 4.77 + 0.000667t \\ wt \times c_p &= 6.75 + 0.000667t \end{aligned} \right\} \text{ for any perfect gas.}$$

For CO_2

$$c_v = 0.15 + 0.000066t$$

$$c_p = 0.195 + 0.000066t$$

For superheated steam. (Approximate.)

$$c_v = 0.324 + 0.000133t$$

$$c_p = 0.435 + 0.000133t$$

Although

$$c_p - c_v = AB$$

is always true the relation

$$\frac{c_p}{c_v} = k = 1.4 \tag{68}$$

is approximately true for ordinary temperatures. Equations (51) and (68) are not both possible for two such equations could only hold for definite values of c_p and c_v . (68) is approximately true since the value of the quantity b is small and as it gives simpler results to certain problems its use is advisable unless there is a great change in temperature on the path considered.

Since

$$c_p - c_v = AB$$

and

$$c_p = kc_v$$

$$AB = (k - 1)c_v$$

or

$$c_p : c_v : AB = k : 1 : k - 1$$

ISOTHERMAL AND ISODYNAMIC LINES

If in equation (65), T is made constant du will be equal to zero, or u is constant. Hence for perfect gases the isothermal is the same as the isodynamic.

Since

$$pv = BT$$

$$pv = \text{constant}$$

is the equation of this line on the pv plane. This is the equation of the rectangular hyperbola.

ADIABATIC

The adiabatic is such a line that $dq = 0$.

From (48).

$$0 = c_v dt + A p dv$$

$$c_v dt = -A p dv = -A \frac{BT}{v} dv$$

$$\frac{c_v}{AB} \frac{dt}{T} = -\frac{dv}{v}$$

$$\therefore \frac{c_v}{AB} \log_e \frac{T_2}{T_1} = \log_e \frac{v_1}{v_2}$$

or

$$\frac{T_2}{T_1} = \left(\frac{v_1}{v_2}\right)^{\frac{AB}{c_v}}$$

but

$$\frac{AB}{c_v} = k - 1$$

hence

$$\frac{T_2}{T_1} = \left(\frac{v_1}{v_2}\right)^{k-1} \quad (69)$$

or

$$Tv^{k-1} = \text{const.}$$

This is the equation of the adiabatic on the vT plane. To reduce this to the equation for the pv plane, T must be eliminated. Now

$$T = \frac{pv}{B}$$

Hence

$$\frac{pv v^{k-1}}{B} = \text{const.}$$

or

$$pv^k = \text{const.} \quad (70)$$

This is the equation of the adiabatic of a perfect gas on the pv plane.

Now

$$v = \frac{BT}{p}$$

Substituting this in (70) gives

$$p \left(\frac{BT}{p}\right)^k = \text{const.}$$

$$p^{\frac{k-1}{k}} T = \text{const.} \quad (71)$$

(69), (70) and (71) are the projections of the adiabatic line of the surface $pv = BT$ (perfect gas) on the three planes of projection.

The line $pv^n = \text{const.}$ is known as a **polytropic** and for the perfect gas this has the three forms on the different planes:

$$pv^n = \text{const.} \quad (72)$$

$$p^{\frac{n-1}{n}} T = \text{const.} \quad (73)$$

$$v^{n-1} T = \text{const.} \quad (74)$$

THERMODYNAMIC LINES

The six important lines used in thermodynamics are the **isothermal** (constant T), **adiabatic** (no heat added from the outside), **isodynamic** (constant intrinsic energy), **constant pressure**, **constant volume** and **polytropic**.

For a perfect gas these lines on the pv plane have the following equations:

- Isothermal, $pv = \text{constant}$
- Adiabatic, $pv^k = \text{constant}$
- Isodynamic, $pv = \text{constant}$
- Constant pressure, $p = \text{constant}$
- Constant volume, $v = \text{constant}$
- Polytropic, $pv^n = \text{constant}$

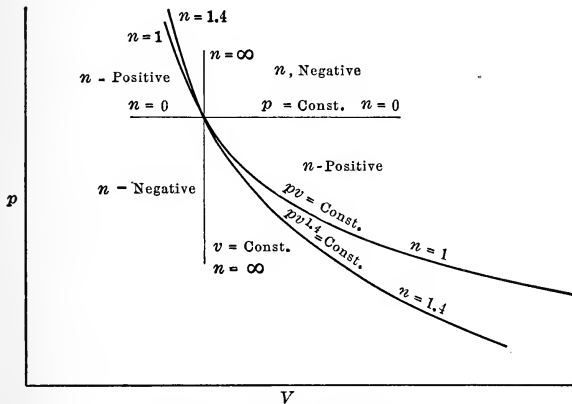

FIG. 7.—Thermal lines.

It is seen that each is of the form $pv^n = \text{constant}$ in which n has certain values.

- $n = 1$ for isothermal and isodynamic
- $n = k$ for adiabatic
- $n = 0$ for constant pressure
- $n = \infty$ for constant volume

These are shown in Fig. 7.

Since these are all of the same form it will be well to investigate the general case first.

$$\begin{aligned}
 pv^n &= \text{const.} \\
 dq &= c_v dt + A p dv \\
 du &= J c_v dt \\
 dW &= p dv \\
 c_v &= \frac{AB}{k-1}
 \end{aligned}$$

$$\therefore (u_2 - u_1) = J c_v (T_2 - T_1) = \frac{B}{k-1} (T_2 - T_1) = \frac{1}{k-1} (p_2 v_2 - p_1 v_1)$$

$$\int dw = \int_{v_1}^{v_2} p dv = \text{const.} \int_{v_1}^{v_2} v^{-n} dv = \text{const.} \left[\frac{v^{1-n}}{1-n} \right]_{v_1}^{v_2}$$

$$\text{Since } p = \frac{\text{const.}}{v^n}$$

Now

$$\text{Work} = \frac{\text{Const.} = p_1 v_1^n = p_2 v_2^n}{\frac{p_2 v_2^n v_2^{1-n} - p_1 v_1^n v_1^{1-n}}{1-n}} = \frac{p_2 v_2 - p_1 v_1}{1-n} \quad (75)$$

When

$$\begin{aligned}
 n &= 1 \\
 p_2 v_2 &= p_1 v_1
 \end{aligned}$$

and the expression for work reduces to

$$\text{Work} = \frac{0}{0}$$

an indeterminate expression. To find the value of the work in this case, the integration must be made by using the substitution for this case.

$$\text{Work} = \int_{v_1}^{v_2} p dv = \text{const.} \int_{v_1}^{v_2} \frac{dv}{v} = \text{const.} \log_e \frac{v_2}{v_1} = p_1 v_1 \log_e \frac{v_2}{v_1} \quad (76)$$

since

$$p = \frac{\text{const.}}{v}$$

The value (75) for work holds for all values of n except for $n = 1$. In this case (76) is the expression for work. Equation (75) may be put in two other forms, thus:

$$\text{Work} = \frac{p_2 v_2 - p_1 v_1}{1-n} = \frac{p_2 v_2 \left(1 - \frac{p_1 v_1}{p_2 v_2}\right)}{1-n} = \frac{p_2 v_2 \left(1 - \left(\frac{p_1}{p_2}\right)^{\frac{n-1}{n}}\right)}{1-n} \quad (77)$$

$$= \frac{p_2 v_2 \left(1 - \left(\frac{v_2}{v_1}\right)^{n-1}\right)}{1-n} \quad (77')$$

Since

$$\frac{p_1 v_1}{p_2 v_2} = \frac{p_1}{p_2} \times \left(\frac{p_1}{p_2}\right)^{-\frac{1}{n}}$$

or

$$\text{work} = \frac{p_1 v_1 \left[\left(\frac{p_2}{p_1}\right)^{\frac{n-1}{n}} - 1 \right]}{1 - n} = \frac{p_1 v_1 \left[\left(\frac{v_1}{v_2}\right)^{n-1} - 1 \right]}{1 - n} \quad (78)$$

The expressions for the heat become:

$$q = \frac{p_2 v_2 - p_1 v_1}{k - 1} + \frac{p_2 v_2 - p_1 v_1}{1 - n} \quad (79)$$

for all values of n except $n = 1$, and

$$q = p_1 v_1 \log_e \frac{v_2}{v_1} \quad (80)$$

for $n = 1$ since there is no change in intrinsic energy on the isothermal. If these do not refer to 1 lb. but to M lbs.

$$Q = (p_2 V_2 - p_1 V_1) \left[\frac{1}{k - 1} + \frac{1}{1 - n} \right] \quad (79')$$

$$Q = p_1 V_1 \log_e \frac{V_2}{V_1} \quad (80')$$

It will be seen from (79') that

$\frac{1}{k - 1} + \frac{1}{1 - n}$ is proportional to the heat,

$\frac{1}{k - 1}$ is proportional to the change of energy, and

$\frac{1}{1 - n}$ is proportional to the work

along the polytropic $p v^n = \text{const.}$ of a perfect gas. It must be remembered that this is only true for perfect gases and on polytropics.

For $n = k$, the expression (79) becomes

$$\frac{p_2 v_2 - p_1 v_1}{k - 1} + \frac{p_2 v_2 - p_1 v_1}{1 - k} = 0$$

or the intrinsic energy change $\frac{p_2 v_2 - p_1 v_1}{k - 1}$ is equal to minus the work. If the final volume is infinity this in the form of (78) reduces to

$$\text{Work} = \frac{p_1 v_1}{k - 1}$$

This is the work under an adiabatic to infinity from the point 1 and hence it is the expression for the intrinsic energy at the point 1.

The expressions (75) and (76) for work are expressions for areas beneath lines and consequently the expressions are true for all substances expanding on these paths.

Since $p_2V_2 = p_1V_1$ on the polytropic $n = 1$ there is no change in intrinsic energy on this line for a perfect gas and it is the division line between positive and negative energy changes.

On the line $n = k$ there is no heat added and so this is the division line between positive and negative heat.

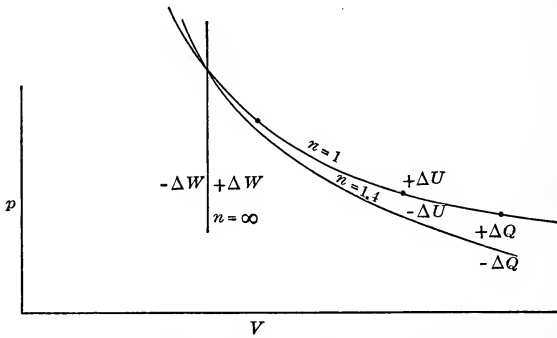

FIG. 8.—Lines of division between positive and negative quantities.

The constant volume line is the division line between positive and negative work.

These are shown in Fig. 8.

EQUALITY OF GAS SCALE AND KELVIN SCALE

Now

$$pv = BT$$

has been derived from the definition of the perfect gas from which

$$\frac{\delta p}{\delta t} = \frac{B}{v} = \frac{p}{T} \quad (81)$$

From (53) which has been derived from absolute considerations

$$du = Jc_v dt + \left[T \frac{\delta p}{\delta t} - p \right] dv$$

Since du is independent of v for a perfect gas by the experiments of Joule and Thompson:

$$\text{(Joules' Law)} \quad T \left(\frac{\delta p}{\delta t} \right)_v - p = 0$$

$$\text{or} \quad \left(\frac{\delta p}{\delta t} \right)_v = \frac{p}{T} \quad (82)$$

(81) and (82) give the same result, hence the absolute Kelvin T of (82) must be the same as the perfect gas T of (81).

HEAT CONTENT OF GASES

$$\text{Since} \quad u = \frac{pv}{k-1}$$

$$i = A \left[\frac{pv}{k-1} + pv \right] = A \frac{k}{k-1} pv \quad (83)$$

$$I = A \frac{k}{k-1} pV \quad (84)$$

For a change

$$I_2 - I_1 = A \frac{k}{k-1} (p_2 V_2 - p_1 V_1) \quad (85)$$

ENTROPY OF GASES

For reversible lines

$$ds = \frac{dq}{T}$$

hence from (48), (49), and (50):

$$s_2 - s_1 = \int c_v \frac{dt}{T} + \int A \frac{p}{T} dv = c_v \log_e \frac{T_2}{T_1} + AB \log_e \frac{v_2}{v_1} \quad (86)$$

$$s_2 - s_1 = c_p \log_e \frac{T_2}{T_1} - AB \log_e \frac{p_2}{p_1} \quad (87)$$

$$s_2 - s_1 = c_p \log_e \frac{v_2}{v_1} + c_v \log_e \frac{p_2}{p_1} \quad (88)$$

These changes in entropy depend only on the states at the beginning and the end of the path.

CYCLES AND CROSS PRODUCTS

Cycles are the paths showing the changes in the properties of a substance as it undergoes a change. They are often shown on the pv plane as in Fig. 9. A **simple cycle** is one made up of two

pairs of similar lines. A cycle of four or more different lines is a **complex cycle**.

The cycles of engines using perfect gases have certain properties provided that they are made up of two pairs of polytropics. If the simple cycle is made up of polytropics, $pv^n = \text{const.}$,

$$V_1V_3 = V_2V_4 \quad (89)$$

$$p_1p_3 = p_2p_4 \quad (90)$$

$$T_1T_3 = T_2T_4 \quad (91)$$

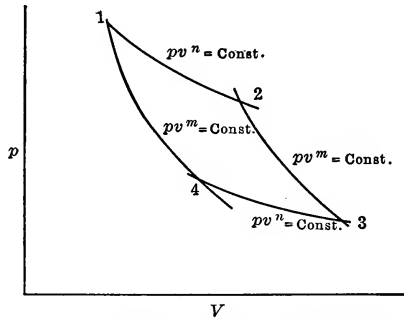

FIG. 9.—Simple cycle of polytropics.

This is shown as follows:

$$\begin{aligned} p_1v_1^n &= p_2v_2^n \\ p_2v_2^m &= p_3v_3^m \\ p_3v_3^n &= p_4v_4^n \\ p_4v_4^m &= p_1v_1^m \\ p_1p_2p_3p_4(v_1v_3)^n(v_2v_4)^m &= p_1p_2p_3p_4(v_1v_3)^m(v_2v_4)^n \\ (v_1v_3)^{n-m} &= (v_2v_4)^{n-m} \\ v_1v_3 &= v_2v_4 \end{aligned} \quad (89)$$

$$\begin{aligned} (p_1p_3)^{\frac{1}{n}-\frac{1}{m}} &= (p_2p_4)^{\frac{1}{n}-\frac{1}{m}} \\ p_1p_3 &= p_2p_4 \end{aligned} \quad (90)$$

If the **cross products** for pressures and for volumes are equal, those for temperature must be equal.

$$\begin{aligned} p_1p_3v_1v_3 &= p_2p_4v_2v_4 \\ B^2T_1T_3 &= B^2T_2T_4 \\ T_1T_3 &= T_2T_4 \end{aligned} \quad (91)$$

This latter is true for perfect gases only. For cycles of any substance the cross products of pressures or volumes are equal

from the geometry of the figure but the cross products of temperatures are only true for perfect gases.

SATURATED STEAM AND OTHER VAPORS

A **vapor** is a gaseous condition of a substance near its point of liquefaction.

When a vapor is in contact with its liquid it is said to be **saturated**.

The characteristic equation for **steam** (due to Bertrand) is

$$\log p = \log k - n \log \frac{T}{T - b} \tag{92}$$

p = pressure in pounds per sq. in.
 T = absolute temperature in deg. F.
 $n = 50$

32° F. to 90° F.	90° F. to 237° F.	238° F. to 420° F.
$b = 140.1$	$b = 141.43$	$b = 140.8$
$\log k = 6.23167$	$\log k = 6.30217$	$\log k = 6.27756$

For **other vapors** Goodenough gives the Dupré-Hertz formula with the value of constants from Bertrand.

$$\log p = a - b \log T - \frac{C}{T} \tag{93}$$

p = pressure in millimeters of mercury
 T = absolute temperature in degree C.

	a	b	c
Water	17.44324	3.8682	2795.0
Ether	13.42311	1.9787	1729.97
Alcohol	21.44687	4.2248	2734.8
Sulphur dioxide	16.99036	3.2198	1604.8
Ammonia	13.37156	1.8726	1449.8
Carbon dioxide	6.41443	-0.4186	819.77

These equations are rarely used since tables of the properties of vapors have been constructed giving the pressures and corresponding temperatures. From the characteristic equations of saturated vapors it is seen that the pressure and temperature are independent of the volume. When heat is added to 1 lb. of liquid at 32° F. and of volume v' it is found that the volume increases a very slight amount so that dv may be considered as zero, giving $dq = c_v dt$, or better cdt to include the slight amount of work.

The value of c has been determined experimentally for different temperatures, hence if these be plotted as functions of t , the area beneath the curve will give the value of the integral

$$q' = \int_{32}^t c dt \quad (94)$$

This is called the **heat of the liquid**. It is the amount of heat to raise 1 lb. of liquid from 32 to some temperature t . For water it is found graphically by plotting c but for other substances the quantity is found by empirical equations of the form

$$q' = a + bt + ct^2 + \dots \quad (95)$$

$$c = \frac{dq'}{dt} = b + 2ct + 3dt^2 + \dots \quad (96)$$

After the liquid has been heated to the temperature corresponding to the pressure, the addition of heat causes the liquid to boil and some of the liquid is changed into vapor. When all is changed into vapor the volume of 1 lb. is v'' so that the volume has been changed by the amount

$$v'' - v' = \text{change of volume.}$$

If x represents the amount of 1 lb. which has been changed into steam it is called the **quality**, $(1 - x)$ is the amount which remains liquid. The volume of the 1 lb. of mixture is

$$v = v' + x(v'' - v') = (1 - x)v' + xv'' \quad (97)$$

$$V = M[(1 - x)v' + xv''] \quad (98)$$

Since v' is small and since $(1 - x)$ is small in most cases, $(1 - x)v'$ may be neglected, giving

$$V = Mxv'' \quad (99)$$

The amount of heat added to change 1 lb. of liquid from liquid at the boiling point to vapor at this temperature is called the **heat of vaporization** and is represented by r .

$$r = \int dq = \int c_v dt + \int AT \left(\frac{\delta p}{\delta t} \right)_v dv$$

Now T is constant and $\left(\frac{\delta p}{\delta t} \right)$ is independent of v , hence

$$\begin{aligned} r &= AT \left(\frac{\delta p}{\delta t} \right) \int_{v'}^{v''} dv \\ &= AT \left(\frac{\delta p}{\delta t} \right)_v (v'' - v') \end{aligned} \quad (100)$$

This equation may be used to find r if $v'' - v'$ is known. Since r is usually found by an empirical equation, equation (100) is used to compute $(v'' - v')$.

For steam

$$r = 970.4 - 0.655(t - 212) - 0.00045(t - 212)^2 \quad (101)$$

The total heat added to 1 lb. of liquid at 32° F. to make it into steam at a given temperature is called the **total heat**, q'' or

$$q'' = q' + r \quad (102)$$

For steam

$$q'' = 1150.4 + 0.35(t - 212) + 0.000333(t - 212)^2 \quad (103)$$

For other substances the equations may be found in tables of properties.

Having r , $v'' - v'$ may be found; since by (92),

$$\begin{aligned} \frac{dp}{dt} &= \frac{nbp}{T(T - b)} \\ v'' - v' &= \frac{r}{AT \frac{nbp}{T(T - b)}} \end{aligned} \quad (104)$$

If the volume is changed by $v'' - v'$ at a pressure p , the **external work** expressed in heat units is

$$A \text{ work} = Ap(v'' - v') = \Psi \quad (105)$$

The **internal heat of vaporization** is therefore

$$\rho = r - \Psi \quad (106)$$

This is computed and placed in the tables.

If the steam or vapor is such that no liquid is present, $x = 1$ and the vapor is **dry**. However, if there is some liquid, x is not unity and the vapor is **wet**. In either case it is a **saturated vapor** as the pressure and temperature are related by means of the characteristic equation of saturated vapor. When x is not unity the total heat is

$$q_x'' = q' + xr$$

INTRINSIC ENERGY

There is practically no work when the liquid is heated, hence the quantity of heat q' remains in the body and when steam is made the change of intrinsic energy is given by

$$\begin{aligned} A(u - u_{32}) &= q' + r - Ap(v'' - v') \\ &= q' + \rho \end{aligned}$$

Since the intrinsic energy may be measured from 32° F., this may be written

$$Au = q' + \rho, \text{ or } AU = M(q' + \rho) \quad (107)$$

For wet vapor

$$Au = q' + x\rho, \text{ or } AU = M(q' + x\rho). \quad (107')$$

HEAT ON A PATH

If heat is added to a vapor on some path as in Fig. 10

$$\begin{aligned} q &= A(U_2 - U_1) + A \int p dV \\ &= AM [q'_2 + x_2\rho_2 - q'_1 - x_1\rho_1] + A \int p dV \end{aligned}$$

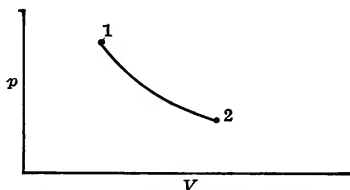

FIG. 10.—Path on pV plane.

The area beneath the curve is the value of the integral. This may be of any of the forms given earlier.

To find x the formula

$$x = \frac{V}{Mv''} \quad (108)$$

is used.

HEAT CONTENT

At times steam tables and charts give the value of the **heat content** and the method of using this must be clearly understood.

$$\begin{aligned} i &= A(u + pv'') \\ &= q' + r' - Ap(v'' - v') + Apv'' \\ &= q' + r' - Apv' \end{aligned}$$

Now Apv' is a very small quantity, hence i and q'' are almost the same. If, however, i is given

$$i - Apv' = Au \quad (109)$$

so that for

$$\begin{aligned} &A(u_2 - u_1) \\ &i_2 - Ap_2v_2 - (i_1 - Ap_1v_1) \end{aligned}$$

may be written and problems solved.

ENTROPY

The **entropy change** when the liquid is heated is

$$S_t - S_{32} = \int_{491.6}^T c \frac{dt}{T} = \int_{91.6}^T cd(\log_e T) = s' \quad (110)$$

This entropy of the liquid is found graphically as the area under a curve of c plotted against $\log T$.

When the liquid at the boiling point is vaporized

$$\int_{x=0}^{x=1} ds = \int \frac{dq}{T} = \int \frac{rdx}{T} = \frac{r}{T} \int_0^1 dx = \frac{r}{T} \quad (111)$$

The total **change of entropy** from liquid at 32° F. into dry vapor is

$$s'' - s_{32} = s' + \frac{r}{T}$$

Since 32° F. is the datum plane of reference

$$s'' = s' + \frac{r}{T} \quad (112)$$

For wet vapor $s'' = s' + \frac{xr}{T} \quad (112')$

DIFFERENTIAL EFFECT OF HEAT

When a mixture of liquid and vapor has a differential amount of heat added to it, an amount dx of liquid is vaporized, and the liquid $(1 - x)$ and the vapor x are raised dt degrees. If c' is the specific heat of the liquid and c'' that of the vapor,

$$dq = c'(1 - x) dt + c'' \times dt + rdx$$

Now $ds = \frac{dq}{T} = \frac{c'(1 - x) + c''x}{T} dt + \frac{r}{T} dx$

This is an exact differential, hence

$$\begin{aligned} \frac{\delta}{\delta x} \left(\frac{c'(1 - x) + c''x}{T} \right)_T &= \frac{\delta}{\delta T} \left(\frac{r}{T} \right)_x \\ -\frac{c'}{T} + \frac{c''}{T} &= \frac{1}{T} \frac{\delta r}{\delta T} - \frac{r}{T^2} \\ c'' &= c' - \frac{r}{T} + \frac{\delta r}{\delta T} \end{aligned} \quad (113)$$

as

$$c' = \frac{dq'}{dT}$$

and

$$\frac{dq''}{dt} = \frac{dq'}{dt} + \frac{dr}{dt}$$

$$\therefore c'' = \frac{dq''}{dT} - \frac{r}{T} \quad (113')$$

Since
$$q'' = a + b(t - 212) - c(t - 212)^2$$

$$\frac{dq''}{dt} = b - 2c(t - 212)$$

may be substituted and c'' may be found.

SUPERHEATED VAPOR

If the **saturated vapor** is taken away from its liquid so that additional heat will not vaporize any liquid, the addition of heat will cause the temperature to rise above its saturation value if the pressure is kept constant. This vapor is known as **superheated vapor**.

The **equation for superheated steam** as reduced by Goodenough from the work of Knoblauch, Linde and Klebe is

$$v + c = \frac{BT}{p} - (1 + ap) \frac{m}{T^n} \quad (114)$$

p = pressure in pounds per square inch

v = volume of 1 lb. in cu. ft.

$B = 0.5963$

$\log m = 13.67938$

$n = 5$

$c = 0.088$

$a = 0.0006$.

For other substances the equation of Zeuner is used

$$pv = BT - cp^n \quad (115)$$

For high temperatures Mallard and Le Chatelier and Langen give for the specific heat of superheated steam at constant pressure

$$c_p = 0.439 + 0.000239t \quad (116)$$

but from (56) according to Goodenough

$$\left(\frac{\delta c_p}{\delta p}\right)_T = -AT \frac{\delta^2 v}{\delta t^2}$$

From (114)
$$\frac{\delta v}{\delta t} = \frac{B}{p} + \frac{mn}{T^{n+1}}(1 + ap)$$

$$\frac{\delta^2 v}{\delta t^2} = -\frac{mn(n+1)}{T^{n+2}}(1 + ap) = -\left(\frac{\delta c_p}{\delta p}\right)_T \frac{1}{AT}$$

$$\therefore c_p = \frac{Amn(n-1)}{T^{n+1}}p \left(1 + \frac{a}{2}p\right) + \phi T \quad (117)$$

Using (116) as the form of expression for ϕT

$$c_p = \alpha + \beta T + \frac{A m n (n - 1)}{T^{n+1}} p \left(1 + \frac{a}{2} p \right)$$

From the results of Knoblauch and Mollier, Goodenough reduces for α and β the values

$$\begin{aligned} \alpha &= 0.367 \\ \beta &= 0.0001 \end{aligned}$$

giving $c_p = 0.367 + 0.0001T + p(1 + 0.0003p) \frac{C}{T^6}$ (117')

$$\log C = 14.42408$$

p = pounds per square inch

T = degrees absolute F.

This value of c_p agrees with the results of experiment by Knoblauch and Mollier. Values of this are shown in Fig. 11 as given by Goodenough.

The value of the specific heat of other superheated vapors is given below and these are usually taken as constants although this is not true.

SPECIFIC HEATS AT CONSTANT PRESSURE AND K'S

Superheated ammonia vapor	0.536	k = 1.32
Superheated sulphur dioxide	0.1544	k = 1.26
Superheated carbon dioxide	0.215	k = 1.30
Superheated chloroform	0.144	k = 1.10
Superheated ether	0.462	k = 1.03

If now 1 lb. of liquid at 32° F. is heated and finally changed into superheated vapor at temperature $T_{sup.}$ the amount of heat required is given by

$$q''' = q' + r + \int_{T_{sat.}}^{T_{sup.}} c_p dt \tag{118}$$

The last term is found graphically or analytically for different pressures and different amounts of superheat and tabulated or plotted in charts so that q''' may be known.

The value of $\int_{T_{sat.}}^{T_{sup.}} c_p dv$ may be written as
 (mean c_p) ($T_{sup.} - T_{sat.}$)

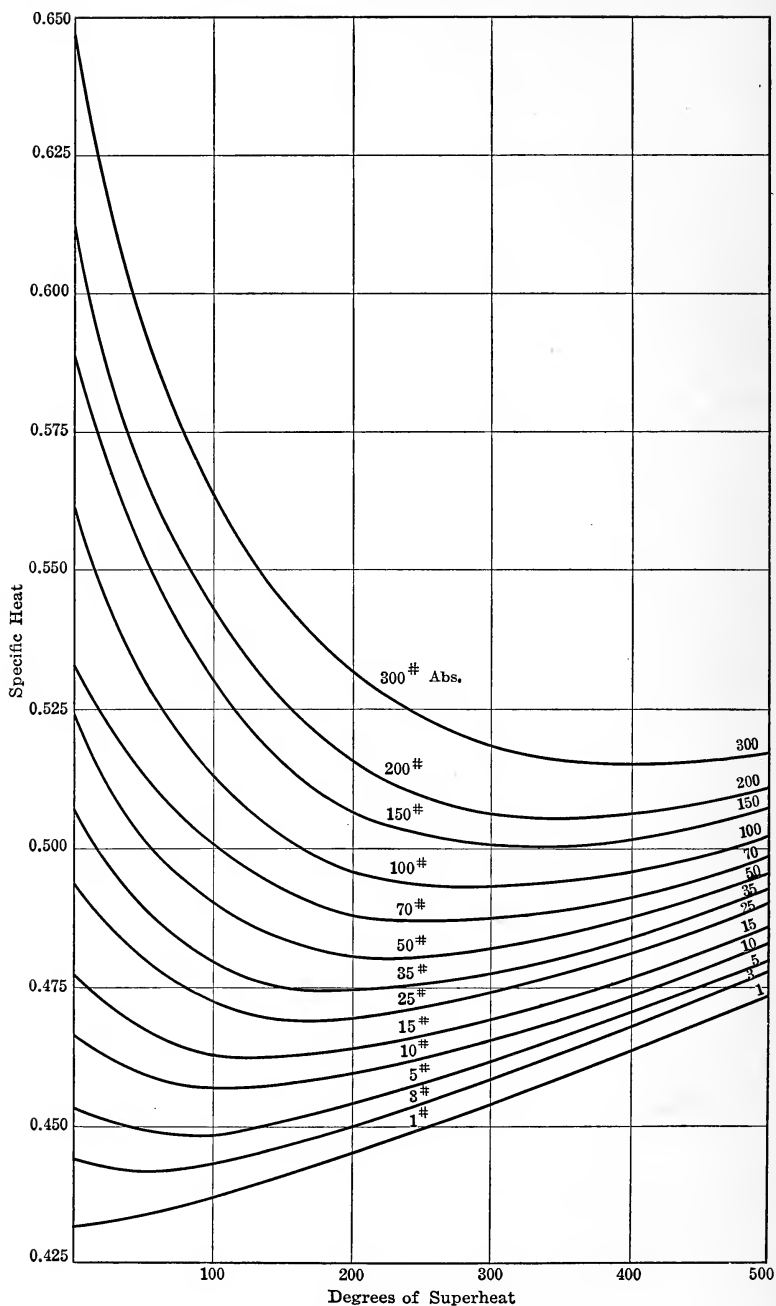

FIG. 11.—Specific heat of superheated steam.

The value of mean c_p is given by

$$\text{mean } c_p = \frac{\int_{T_{sat.}}^{T_{sup.}} c_p dt}{T_{sup.} - T_{sat.}}$$

The values of mean c_p have been compared and plotted in the form of curves by Goodenough. From these curves the table on p. 48 has been constructed:

The volume of this superheated steam is computed by (114) and tabulated or plotted.

The heat remaining is

$$Au = q''' - Ap(v''' - v')$$

But $Au = i - Apv'''$. (109)

$$\therefore i = q''' + Apv'$$

$$i = q''' \text{ practically.}$$

The **entropy of the superheated vapor** measured from liquid at 32° F. is

$$s''' = s' + \frac{r}{T} + \int_{T_{sat.}}^{T_{sup.}} c_p \frac{dt}{T} \tag{119}$$

This last term is found analytically or graphically, but in most cases these have been tabulated for steam so that values of s''' may be found for definite conditions.

The various quantities for saturated steam mixtures and superheated steam may be found and these properties are often made into charts. The quantities p, v, t, s, u, i, x are all dependent on the state and, if known, fix the state. Usually any two of them fix the state, so that these two could be used for the coordinates of a diagram. As has been shown before, T and S could be used, and in this the area under a line represents the heat added from the outside if the line is reversible or the heat added from the outside together with friction if the line is non-reversible.

Other coordinates such as **i** and **s** have been proposed by **Mollier**. This is known as a **Mollier diagram**. These will now be explained.

T-S AND I-S CHARTS

In Fig. 12 the coordinates T - S are used and since heat is added to the water at 32° F. the line of

$$s' = \int_{491.6}^T c \frac{dt}{T}$$

MEAN SPECIFIC HEATS OF SUPERHEATED STEAM

Absolute pressures in pounds per square inch

Degrees of super-heat	1	2	3	5	7	10	15	25	35	50	75	100	125	150	200	250	300
0	0.432	0.439	0.444	0.453	0.459	0.466	0.478	0.493	0.507	0.522	0.548	0.559	0.572	0.588	0.610	0.629	0.645
10	0.432	0.439	0.444	0.453	0.458	0.465	0.476	0.491	0.505	0.519	0.545	0.555	0.568	0.583	0.602	0.623	0.640
20	0.432	0.439	0.444	0.452	0.458	0.464	0.475	0.490	0.503	0.517	0.542	0.552	0.564	0.579	0.597	0.617	0.633
30	0.432	0.439	0.444	0.452	0.457	0.463	0.473	0.488	0.501	0.514	0.538	0.549	0.562	0.575	0.594	0.612	0.627
40	0.433	0.439	0.444	0.451	0.456	0.463	0.473	0.487	0.499	0.512	0.535	0.546	0.558	0.571	0.589	0.607	0.623
50	0.433	0.439	0.444	0.451	0.456	0.462	0.472	0.486	0.497	0.510	0.533	0.543	0.556	0.567	0.586	0.603	0.618
60	0.433	0.439	0.444	0.450	0.456	0.462	0.470	0.485	0.495	0.508	0.530	0.540	0.553	0.564	0.582	0.599	0.614
70	0.433	0.439	0.444	0.450	0.455	0.461	0.470	0.484	0.493	0.507	0.528	0.538	0.550	0.561	0.576	0.595	0.609
80	0.433	0.439	0.443	0.450	0.455	0.460	0.469	0.483	0.492	0.505	0.526	0.536	0.548	0.558	0.575	0.591	0.605
90	0.434	0.439	0.443	0.449	0.455	0.460	0.468	0.482	0.491	0.504	0.524	0.533	0.545	0.556	0.573	0.588	0.601
100	0.434	0.439	0.443	0.449	0.454	0.459	0.468	0.482	0.490	0.503	0.523	0.531	0.543	0.553	0.570	0.585	0.598
120	0.435	0.440	0.443	0.449	0.454	0.459	0.467	0.480	0.488	0.500	0.519	0.527	0.538	0.548	0.565	0.578	0.592
140	0.435	0.440	0.443	0.449	0.454	0.458	0.467	0.479	0.486	0.498	0.517	0.524	0.535	0.543	0.560	0.573	0.586
160	0.436	0.440	0.444	0.449	0.454	0.458	0.466	0.478	0.485	0.497	0.515	0.522	0.532	0.540	0.556	0.568	0.581
180	0.436	0.441	0.445	0.450	0.454	0.458	0.466	0.477	0.484	0.495	0.511	0.519	0.529	0.537	0.552	0.564	0.576
200	0.437	0.442	0.445	0.450	0.454	0.458	0.466	0.476	0.483	0.493	0.510	0.517	0.527	0.534	0.549	0.561	0.572
220	0.438	0.442	0.445	0.450	0.455	0.458	0.465	0.475	0.482	0.492	0.508	0.515	0.523	0.532	0.545	0.558	0.568
240	0.439	0.443	0.446	0.451	0.455	0.459	0.465	0.475	0.481	0.490	0.506	0.513	0.521	0.529	0.542	0.554	0.564
270	0.440	0.444	0.446	0.452	0.455	0.459	0.465	0.474	0.481	0.489	0.503	0.510	0.518	0.526	0.538	0.550	0.560
300	3.441	0.445	0.447	0.452	0.456	0.460	0.466	0.474	0.481	0.488	0.503	0.508	0.516	0.523	0.535	0.546	0.555
325	0.442	0.446	0.448	0.453	0.457	0.461	0.466	0.474	0.481	0.488	0.500	0.507	0.514	0.522	0.533	0.543	0.553
350	0.443	0.447	0.449	0.454	0.457	0.462	0.467	0.475	0.482	0.488	0.499	0.506	0.513	0.520	0.531	0.541	0.550
375	0.444	0.448	0.450	0.455	0.458	0.462	0.467	0.475	0.482	0.487	0.499	0.505	0.513	0.519	0.530	0.539	0.548
400	0.445	0.449	0.451	0.456	0.459	0.463	0.468	0.475	0.482	0.487	0.498	0.505	0.512	0.518	0.528	0.537	0.546
450	0.448	0.451	0.453	0.458	0.461	0.464	0.468	0.476	0.483	0.487	0.498	0.504	0.510	0.516	0.526	0.534	0.543
500	0.450	0.453	0.456	0.460	0.463	0.466	0.470	0.477	0.484	0.487	0.498	0.504	0.509	0.515	0.524	0.532	0.540
550	0.452	0.456	0.458	0.462	0.465	0.468	0.472	0.478	0.484	0.488	0.498	0.504	0.509	0.514	0.523	0.530	0.537
600	0.455	0.458	0.461	0.465	0.467	0.470	0.474	0.479	0.484	0.488	0.498	0.504	0.509	0.514	0.523	0.529	0.531

starts at 32° F. or 491.6° abs. F. This line is shown as the **liquid line** in Fig. 12. The various values of s' for different values of T from the steam tables are plotted. From points on the liquid line the distances $\frac{r}{T}$ for those temperatures are laid off giving the **saturation line**. It is evident that these two lines approach

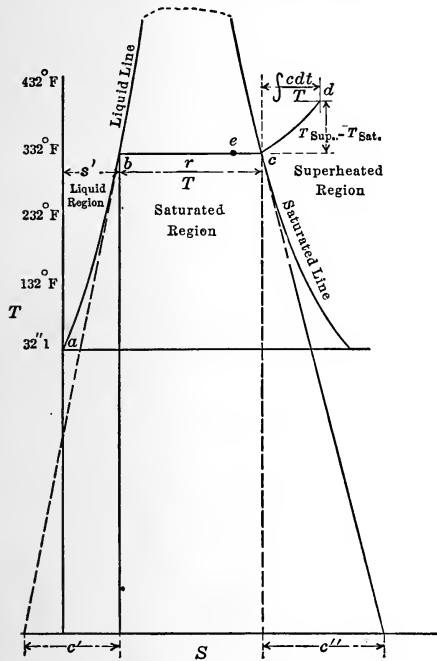

FIG. 12.— TS diagram for TS analyses.

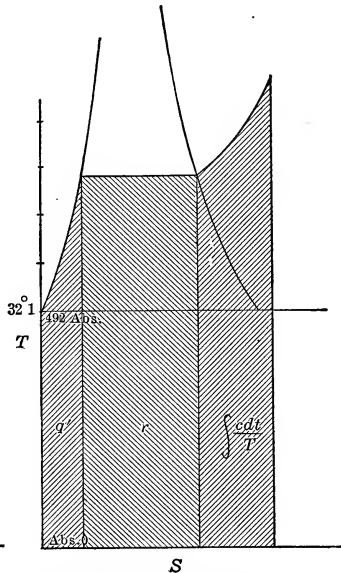

FIG. 13.— TS diagram areas.

and meet at the **critical temperature** (at which the superheated, saturated and liquid states coincide), since at this point $r = 0$.

Since $dq = Tds$
 and $dq = cdt$

$$c = T \frac{ds}{dt} \tag{120}$$

or the specific heat is the subtangent from any point on a curve on the $T-S$ plane. In Fig. 12 it will be seen that while the specific heat of the liquid is positive, the specific heat of saturated steam is negative.

The areas beneath lines on which there is no friction are equal to the heat added. As shown in Fig. 13, the area beneath

the liquid line is q' while that beneath the line from the liquid line to the saturation line is r . It must be remembered distinctly that steam tables and diagrams assume that steam is made by keeping the pressure constant, heating the water from 32° F. to the boiling point, boiling to dry vapor and then superheating at constant pressure. If superheating takes place the temperature will rise by the degrees of superheat and the entropy will increase by

$$\int \frac{c_p dt}{T}$$

the line will therefore take the shape cd . The broken line $abcd$ is a **line of constant pressure**. The area beneath cd is

$$\int c_p dt$$

If the steam is wet the change of entropy from the liquid condition is $\frac{xr}{T}$, and hence if point e is so selected that

$$\frac{be}{bc} = x$$

the point e represents the condition of quality x since $bc = \frac{r}{T}$.

If now for various temperatures (and consequently saturation pressures) various points be found, having the same value of x , a **line of constant quality** or **constant steam weight** may be obtained as shown in Fig. 14.

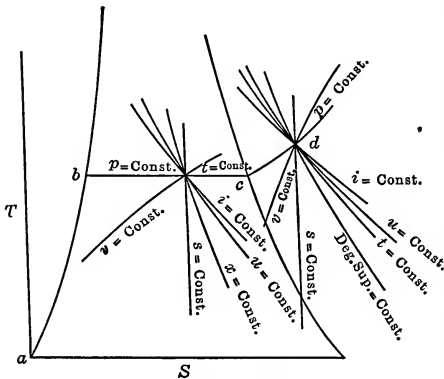

FIG. 14.—Lines on T/S plane.

In the superheated region this is replaced by lines of **constant amount of superheat**. In this case points on various pressure lines at the same number of degrees above saturation are connected.

If the value of i be computed for point e and this is made equal to the i at some other temperature the quality at this point may be found and from it the position of e on that line.

$$q' + xr = q'_1 + x_1 r_1$$

$$x_1 = \frac{q' + xr - q'_1}{r_1}$$

If a number of points are found, a line of **constant heat content** is obtained. In the superheated region

$$q' + r + \int c_p dt = q'_1 + r_1 + \int c_p dt$$

and the values of the degrees of superheat at the second pressures are found to give the same heat content as at the first point. Such points form the line of constant heat content.

It is known that

$$u = q' + xp \text{ or } u = i - Apv$$

Hence if the value of u at point e is equated to the expression at another pressure or temperature, the quality x or the degrees of superheat may be found for the second pressure or temperature and this fixes the position of the point. Connecting a series of these the **line of constant intrinsic energy** is found.

If the volume of the point e is found as

$$v = xv''$$

and equated to $x_1 v''_1$ for a different pressure the value of x may be found, and from a series of these points a **line of constant**

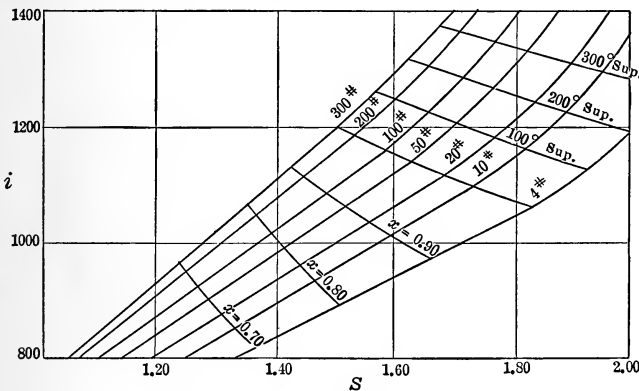

FIG. 15.—Mollier chart.

volume. In the superheated region the long formula for superheated steam would have to be used and by equating this for two pressures the degrees of superheat at the second point could be found and in this way the curve could be determined.

The **lines of constant S** and **constant temperature** are vertical and horizontal lines.

A diagram such as Fig. 14 is used in practice in which lines of constant i , x , v , deg.-sup., s and t are drawn at equal distances apart.

In the **Mollier chart**, Fig. 15, similar methods are used to compute various points. The lines shown are **constant quality** and **pressure** on i - s coordinates and to this diagram should be added lines of constant volume.

For a definite pressure

$$s = s' + \frac{xr}{T} \quad \text{or} \quad s' + \frac{r}{T} + \int c_p \frac{dt}{T}$$

$$\text{and} \quad i = q' + xr - Apv' \quad \text{or} \quad q' + r + \int c_p dt - Apv'$$

and for different values of x or degrees of superheat at the same pressure the values of i and s may be found giving a line of constant pressure.

If this is done for several pressures and then the points of the same quality are connected the lines of equal quality and equal pressure are found. If

$$v = xv''$$

or the equation for superheated steam is used the conditions at different pressures for the same volume may be found and, from these, lines of constant volumes. Fig. 15 shows this chart.

Having these charts and formulæ, the various lines may be discussed. On all lines the important things are the work, heat and change of entropy.

HEAT ON PATHS

If Fig. 16 represents any line the heat added on it is given by

$$JQ = U_2 - U_1 + \int pdv$$

$$\int pdv = \text{work}$$

To find this analytically the equation of the curve must be known and if this is not known the area beneath the curve must be found by a planimeter and the graphical method used to evaluate the integral. If the curve is concave upward, as

shown dotted in Fig. 16, it may be assumed to be of the form $pv^n = \text{const.}$, in which case

$$\int pdv = \frac{p_2V_2 - p_1V_1}{1 - n}$$

for all values of n except unity; n must be known for this and from the pressures and volumes at 1 and 2 it is found as follows:

$$\begin{aligned} p_1V_1^n &= p_2V_2^n \\ \frac{p_1}{p_2} &= \left(\frac{V_2}{V_1}\right)^n \\ n &= \frac{\log \frac{p_1}{p_2}}{\log \frac{V_2}{V_1}} \end{aligned} \tag{121}$$

Of course this is the value of n of a curve of this form passing between the end points 1 and 2, but it may not pass through the other points.

The specific volumes at points 1 and 2 are now found by dividing the volume by M after which these specific volumes and pressures are used on charts or in tables.

$$\begin{aligned} U &= M(i - Apv) \\ \text{or } U &= M(q' + xp) \end{aligned}$$

To find this, i or x must be known. If from tables or charts i may be found, then the first formula is the one to use as it applies to saturated and superheated conditions. If, however, the table does not go low enough x is found by

$$\begin{aligned} x_1 &= \frac{V_1}{Mv''_1} \\ x_2 &= \frac{V_2}{Mv''_2} \end{aligned}$$

Of course M must be given in the problem; v'' is taken from the steam tables.

Having U_2 and U_1 their difference is known and from this and work the heat is found by addition.

The change of entropy is determined by finding the entropies

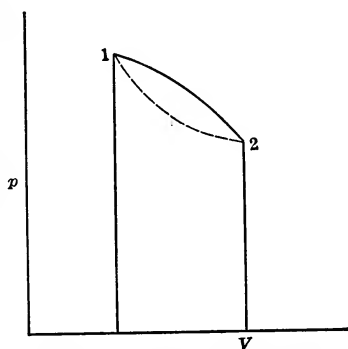

FIG. 16.—Path on pV plane.

at 1 and 2 from charts or tables or if these cannot be used they must be computed

$$s = s' + \frac{xr}{T}$$

The entropy change is then

$$S_2 - S_1 = M(s_2 - s_1)$$

This is for any line. For the adiabatic, the heat is zero, the entropy change is zero, and the work is equal to the change in intrinsic energy. The entropy is constant on this line and this gives the **equation of the adiabatic**

$$s'_1 + x_1 \frac{r_1}{T_1} = s'_2 + x_2 \frac{r_2}{T_2} \quad (122)$$

or

$$= s'_2 + \frac{r_2}{T_2} + \int_{T_{sat.}}^{T_{sup.}} c_p \frac{dt}{T}$$

Knowing the first point through which the curve must be drawn, the unit volume is found by

$$v = \frac{V}{M}$$

From tables or charts the quality is found for this specific volume. If this cannot be found on account of the limits of these tables

$$x = \frac{v}{v''}$$

The entropy of the first point being known, the quality at the second point is found by (122) and from this the volume, if needed, is

$$V = Mxv'' \text{ or } Mv$$

If v can be found from tables or charts, it is easier to get it from the same entropy column or line. The work is then given by

$$\begin{aligned} \text{Work} &= U_1 - U_2 = M(u_1 - u_2) \\ u &= i - Apv \text{ or } q' + xp \end{aligned}$$

At times the difference between the u 's would lead to such an error that it is better to find V_2 for a given p_2 and then compute n by the log formula (121) and find work by

$$\text{Work} = \frac{p_2 V_2 - p_1 V_1}{1 - n}$$

The **isodynamic** is a line of constant U .

$$U_1 = U_2$$

$$Mu_1 = Mu_2$$

Now $u_1 = i - Apv$ or $q' + xp$

$$\therefore i_1 - Ap_1v_1 = i_2 - Ap_2v_2 \text{ or } q'_1 + x_1p_1 = q'_2 + x_2p_2 \quad (123)$$

Given the pressure, volume and weight at the first point, the quality is found after determining the specific volume by using the tables and charts if possible; or by using the formula for superheated steam or

$$x = \frac{v}{v''}$$

The value of u_1 may then be found and this is equated to u_2 for the second pressure from which the second quality may be computed and then the volume is found by

$$V_2 = Mx_2v''_2$$

The heat in this case is equal to the work since there is no change of intrinsic energy. The work is found by finding n by formula (121) and then

$$\text{Work} = \frac{p_2V_2 - p_1V_1}{1 - n}$$

The values of s_2 and s_1 are found and then

$$S_2 - S_1 = M(s_2 - s_1)$$

The **isothermal** in the saturated region is the same as the **constant pressure** line and on this

$$Q = M(x_2 - x_1)r \quad (124)$$

$$\text{Work} = M(x_2 - x_1)\psi \quad (125)$$

$$S_2 - S_1 = M(x_2 - x_1) \frac{r}{T} \quad (126)$$

In the superheated region the curve approaches the **rectangular hyperbola** and it would be difficult to solve problems on this line if tables were not available. In this case the formula for superheated steam would have to be used to get the volumes or if tables or charts were used the volumes could be found by finding the degrees of superheat at various pressures by

$$\text{Degree superheat} = T - T_{sat.}$$

and this would fix i , v and s . Then

$$\begin{aligned}\text{Work} &= \frac{p_2 V_2 - p_1 V_1}{1 - n} \\ U_2 - U_1 &= M(i_2 - A p_2 v_2 - [i_1 - A p_1 v_1]) \\ Q &= U_2 - U_1 + \text{work} \\ S_2 - S_1 &= M(s_2 - s_1)\end{aligned}$$

On the **constant volume line**

$$\begin{aligned}\text{Work} &= 0 \\ x &= \frac{V}{M v''} \\ U_2 - U_1 &= Q = M[q'_2 + x_2 p_2 - (q'_1 + x_1 p_1)] \\ S_2 - S_1 &= M(s_2 - s_1)\end{aligned}$$

FLOW OF FLUIDS

If a fluid flows through an orifice in which there is a change in section there is a drop in pressure and as a result there is a change in velocity.

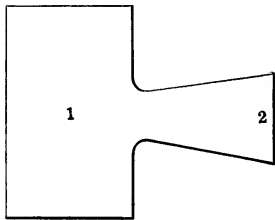

FIG. 17.—Orifice for flow of fluid.

In Fig. 17 consider the sections 1 and 2. If the areas are represented by F_1 and F_2 , the pressures by p_1 and p_2 , the specific volumes by v_1 and v_2 , the velocities by w_1 and w_2 the following considerations must hold when M pounds of substance flow per second.

$$\begin{aligned}\text{Kinetic energy at 1 in ft-lbs.} &= \frac{M w_1^2}{2g} \\ \text{Internal energy at 1} &= M u_1 \\ \text{Work done in pushing substance along} &= M p_1 v_1 \\ \text{Hence total energy at 1} &= M \left(\frac{w_1^2}{2g} + u_1 + p_1 v_1 \right) \\ \text{Total energy at 2} &= M \left(\frac{w_2^2}{2g} + u_2 + p_2 v_2 \right)\end{aligned}$$

Now if there is any heat added between these two points, say MJq , the energy at 2 must equal that at 1 plus MJq . Of course if Jq is taken away the sign would change.

$$\text{Hence } \frac{w_1^2}{2g} + u_1 + p_1 v_1 + Jq = \frac{w_2^2}{2g} + u_2 + p_2 v_2 \quad (127)$$

$$\begin{aligned}\text{or } \frac{w_2^2 - w_1^2}{2g} &= Jq + u_1 + p_1 v_1 - (u_2 + p_2 v_2) \\ &= Jq + J(i_1 - i_2) \quad (128)\end{aligned}$$

$$\text{since } u_1 + p_1 v_1 = J i_1$$

If now F_1 is so large that w_1 is small and if $q = 0$, the formula becomes

$$\frac{w_2^2}{2g} = J(i_1 - i_2) \tag{129}$$

or
$$w_2 = \sqrt{2gJ(i_1 - i_2)} \tag{130}$$

Since $q = 0$ this action is adiabatic but in the case that there be internal friction, 1 and 2 are not on points on an isoentropic line but a line passing to the right of this line on the T - S plane. In other words, i_2 is greater than it would have been if there had been no friction. The amount of this increase in i_2 is usually found by assuming that 2 has the same entropy as 1 and then in-

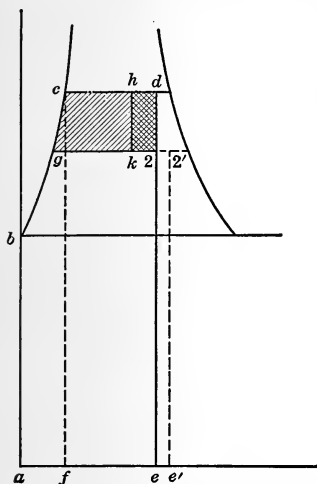

FIG. 18.— TS diagram for flow of fluids.

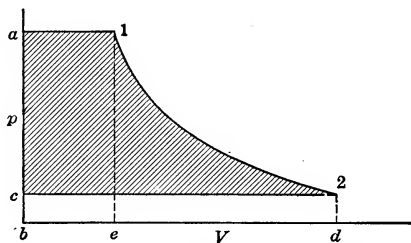

FIG. 19.— pV diagram for flow of fluids.

stead of using $i_1 - i_2$ for these points, only a fraction of this is used. In Fig. 18 $abcde$ is equal to i_1 , since

$$\begin{aligned} abc f &= q' \\ c d e f &= x r \\ a b c d e &= q' + x r = i - A p v' = i \\ a b g 2 e &= i_2 \\ i_1 - i_2 &= c d 2 g \end{aligned}$$

This assumes no friction, hence d and 2 have the same entropy. By experiment the heat used in friction is found to be $y(i_1 - i_2)$, hence this must be subtracted to get the amount of heat left to give the gain in kinetic energy. Hence

$$w_2 = \sqrt{2gJ(i_1 - i_2)(1 - y)} \tag{131}$$

i_1 and i_2 are for points on the same entropy line. In Fig. 18 the area $cd2g$ is cut down by the amount $hd2k$ which is equal to

$y(i_1 - i_2)$. This heat stays in the substance and hence at exit i is not the i of 2 but that of 2' which is fixed by making

$$2'e'e2 = hd2k \text{ or } 22' = \frac{hd2k}{T_2}$$

If this value of $i_{2'}$ could have been determined the original formula (130) would have been used. It is because $i_{2'}$ cannot be found that this method of using a portion of the amount for isentropic expansion is employed.

It must be remembered that the shaded area less the friction loss equals the gain of kinetic energy.

$$\frac{w_2^2 - w_1^2}{2g} = J(i_1 - i_2)(1 - y)$$

The quantity $i_1 - i_2$ is the same as the area behind the adiabatic on the pv plane as shown in Fig. 19.

$$\begin{aligned} \text{Area } a12c &= a1eb + e12d - c2db \\ &= p_1v_1 + (u_1 - u_2) - p_2v_2 \\ &= J(i_1 - i_2) \end{aligned}$$

On account of friction this is reduced as pointed out above.

THROTTLING ACTION

Suppose now that there is so much friction that there is no gain in kinetic energy although there is a drop in pressure; this is called **throttling action**. In this case

$$\frac{w_2^2}{2g} - \frac{w_1^2}{2g} = 0 = J(i_1 - i_2)$$

or
$$i_1 = i_2 \tag{132}$$

This means that in **throttling action** the heat content is constant. The point 2' of Fig. 18 then is found to be on a curve of constant heat content. The horizontal lines of the Mollier chart or the constant i curves of the T - S diagrams are **throttling curves** on these diagrams.

Since in perfect gases

$$Ji = \frac{k}{k-1} p_1 V_1 = \frac{k}{k-1} MBT_1 \tag{133}$$

the throttling curves for such are curves of constant temperature.

VELOCITY OF VARIOUS SUBSTANCES

For short tubes and orifices the friction is negligible and the action may be considered isentropic as well as adiabatic.

$$w_2 = \sqrt{2gJ(i_1 - i_2)}$$

For liquids, since the temperature change is slight,

$$i = A p v + \text{const.}$$

$$w_2 = \sqrt{2g[p_1 V_1 - p_2 V_2]} = \sqrt{2g[p_1 - p_2]V}$$

Since

$$V_1 = V_2$$

$$V = \frac{1}{m}$$

$$[p_1 - p_2] \frac{1}{m} = h$$

$$w_2 = \sqrt{2gh} \tag{134}$$

This is the usual formula from hydraulics for the **velocity of a liquid.**

For gases

$$J i_1 = \frac{k}{k-1} p_1 V_1$$

$$w_2 = \sqrt{2g \frac{k}{k-1} (p_1 v_1 - p_2 v_2)} =$$

$$\sqrt{2g \frac{k}{k-1} p_1 v_1 \left[1 - \left(\frac{p_2}{p_1} \right)^{\frac{k-1}{k}} \right]} \tag{135}$$

Since

$$p_1 v_1^k = p_2 v_2^k$$

This is the **formula for velocity** and is a maximum when $p_2 = 0$.

DISCHARGE FROM ORIFICES

Now

$$M v = \text{volume per second} = F w$$

Hence

$$M = \frac{F w_2}{v_2} = \frac{F}{v_2} \sqrt{2g \frac{k}{k-1} p_1 v_1 \left[1 - \left(\frac{p_2}{p_1} \right)^{\frac{k-1}{k}} \right]}$$

$$v_2 = v_1 \left(\frac{p_1}{p_2} \right)^{\frac{1}{k}}$$

$$\therefore M = F \sqrt{2g \frac{k}{k-1} \frac{p_1}{v_1} \left[\left(\frac{p_2}{p_1} \right)^{\frac{2}{k}} - \left(\frac{p_2}{p_1} \right)^{\frac{k+1}{k}} \right]} \tag{136}$$

This is zero when $p_2 = p_1$ and when $p_2 = 0$. Of course the latter is unthinkable because there will always be some weight

when p_2 is less than p_1 . The explanation is that when the pressure p_2 falls the pressure which exists in the plane of the orifice where the area is F can never become less than that to give maximum discharge. To find the condition for a maximum value of M , the variable part of the expression is differentiated. For a fixed p_1 and v_1

$$\left(\frac{p_2}{p_1}\right)^{\frac{2}{k}} - \left(\frac{p_2}{p_1}\right)^{\frac{k+1}{k}}$$

is differentiated with regard to the variable p_2 and by equating this to zero, the condition for a maximum is

$$p_2 = p_1 \left(\frac{2}{k+1}\right)^{\frac{k}{k-1}} \quad (137)$$

When $k = 1.4$ for gases this becomes

$$p_2 = 0.5283p_1 \quad (138)$$

while for steam, $k = 1.135$, and

$$p_2 = 0.574p_1 \quad (139)$$

When p_2 becomes less than the critical value given above for a short mouthpiece, the pressure at this point of area F remains at the critical value. Hence the discharge is constant for all values of p_2 below the critical value. For air this has been proven to be true experimentally by Fliegner who proposes

$$M = 0.53F \frac{p_1}{\sqrt{T_1}} \quad (140)$$

when

$$p_2 < 0.53p_1$$

and

$$M = 1.06F \sqrt{\frac{p_2(p_1 - p_2)}{T_1}} \quad (141)$$

when

$$p_2 > 0.53p_1$$

Equation (140) is really a reduction of (136) by substituting (138) for p_2 and reducing.

For steam similar experimental results have been found by Napier. Rankine reduced these results to the form

$$M = \frac{Fp_1}{70} \quad (142)$$

when

$$p_2 < 0.574p_1 \text{ or } 0.6p_1$$

$$M = \frac{Fp_2}{42} \sqrt{\frac{3(p_1 - p_2)}{2p_2}} \quad (143)$$

when

$$p_2 > 0.6p_1$$

The general equation (131) may be used for the velocity as shown above and then M found by

$$M = \frac{F_2 w_2}{v''_2}$$

after v''_2 is found for the condition at outflow.

CHAPTER II

HEAT ENGINES AND EFFICIENCIES

A **heat engine** is any machine in which heat is used to furnish the energy for the production of mechanical work. As examples, the steam engine, the steam turbine, the gas engine and similar machines may be mentioned.

To make heat available in one of these engines it must be applied to some **substance** which undergoes changes. These changes form a **cycle** and the changes which affect the properties of the substance may be studied on planes of projection by showing the successive values that certain properties take. The paths of the change which the substance undergoes are known as a **cycle**.

As pointed out in the chapter on Fundamental Thermodynamics Q_1 heat units are supplied and Q_2 heat units are rejected, giving $Q_1 - Q_2$ units of work.

All of these machines work between some **range of temperature**, T_1 to T_2 , and consequently the availability of the heat is

$$\frac{T_1 - T_2}{T_1} \quad (1)$$

This is the only part of the heat which could be turned into work and therefore represents the **highest possible efficiency**. It represents the efficiency of the Carnot cycle for this temperature range and therefore it is sometimes spoken of as the **Carnot efficiency** of a given cycle. Of course any cycle would have to be a Carnot cycle to have this efficiency, but all that the term means with reference to a particular cycle is the maximum value that might be possible for this cycle working between T_1 and T_2 . Calling this η_1

$$\eta_1 = \frac{T_1 - T_2}{T_1} = 1 - \frac{T_2}{T_1} \quad (2)$$

If Q_1 is the theoretical amount of heat added and Q_2 the theoretical amount rejected, which cannot be used,

$$\frac{Q_1 - Q_2}{Q_1} = \eta_3 \quad (3)$$

This is the **theoretical efficiency** of the cycle.

The ratio of η_3 and η_1 shows how close the efficiency of the theoretical cycle approaches the maximum possible efficiency of the cycle. This is called the **type efficiency**, η_2

$$\eta_2 = \frac{\eta_3}{\eta_1} \quad (4)$$

If this is nearly unity it indicates that the theoretical cycle is almost equal to that of Carnot and hence in theory the cycle is good while a low value of η_2 shows that the cycle is a poor one theoretically. For example, the steam engine cycle has a value of η_2 above 0.90 while in the case of the gas engine η_2 may be less than 0.50. These indicate that an improvement may be expected in the type of cycle used in a gas engine, although for the steam engine there is little hope of bettering the cycle.

If for an amount of indicated work AW_a the amount of heat Q_a is actually required, the **actual thermal efficiency** η_5 is given by

$$\frac{AW_a}{Q_a} = \eta_5 \quad (5)$$

If the heat supplied per unit of substance used is q_a , be it coal, steam, gas or air, and if M is the amount of substance per indicated horse-power hour, this expression becomes

$$\frac{AW_a}{Q_a} = \frac{\frac{1}{777.64} \times 33000 \times 60}{Mq_a} = \frac{2546}{Mq_a} = \eta_5$$

$$2546 \text{ B.t.u.} = 1 \text{ h.p.-hr.}$$

$$42.43 \text{ B.t.u.} = 1 \text{ h.p.-min.}$$

The ratio of η_5 to η_3 is called the **practical efficiency**, η_4 , and shows how near the actual efficiency approaches the efficiency demanded by theory and a low value of this means that there have been errors in actually applying the cycle. To make this term larger, jackets, superheated steam, and reheaters have been applied to steam engines.

$$\eta_4 = \frac{\eta_5}{\eta_3} \quad (6)$$

If the **mechanical efficiency** η_6 is the ratio of the output to that developed within the machine or shown by the indicator card, this efficiency is found by

$$\eta_6 = \frac{\text{output}}{\text{indicated work}} = \frac{AW_o}{AW_a} \quad (7)$$

The **overall efficiency** is then the product of certain of these various efficiencies.

$$\begin{aligned} \eta &= \frac{\text{output}}{\text{heat supplied}} \\ &= \eta_5 \eta_6 \\ &= \eta_3 \eta_4 \eta_6 \\ &= \eta_1 \eta_2 \eta_4 \eta_6 \end{aligned} \quad (8)$$

The overall efficiency being the product of these, the efficiency may be increased by increasing any of them. In cases such as the gas engine η_1 is so great that although η_2 and η_6 are small the product is greater than that of the steam engine. These various efficiencies will be investigated for different machines.

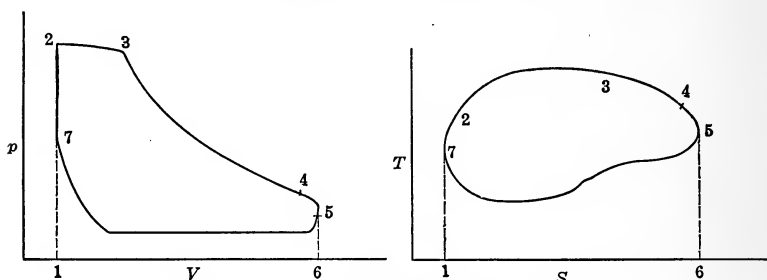

FIG. 20.— pV and TS diagrams of cycles.

The quantity AW_a may be found from the area of the cycle on the pv plane or from the area on the $T-S$ plane in Fig. 20, if the lines are reversible lines. Of course on the pv plane 123456 represents **positive work** while 6571 represents **negative work** and hence 723457 represents the **network**.

On the $T-S$ plane, 123456 represents Q_1 if there is no friction, and 6571 represents Q_2 under these conditions, hence the area of the cycle represents $Q_1 - Q_2$ or the work done. If, however, there is friction

$$12345 = Q_1 + H_1$$

and
$$6571 = (-Q_2 + H_2)$$

since the heat removed to the outside from 5 to 7 is more than that shown by the area on account of the heat developed by friction.

$$23457 = Q_1 - Q_2 + (H_1 + H_2) = AW + H_1 + H_2$$

or the area is greater than the work of the cycle. In any case an irreversible line makes the work less than the area of the cycle on the T - S plane.

Looking at the Carnot cycle of Fig. 21, or the cycle of Fig. 20, it is seen that the efficiency is

$$\frac{2345}{123456} = \frac{Q_1 - Q_2}{Q_1}$$

If in the Carnot cycle heat is not added on 34 but on some other line 3'4 or 34', the heat added and work developed are decreased by the area of the small triangle.

Hence
$$\text{Eff.} = \frac{2345 - 33'4}{123456 - 33'4}$$

Subtracting the same thing from numerator and denominator of a fraction less than unity decreases the value of the fraction. This may be seen by remembering that the effect of the removal of the triangular area is greater on the smaller area. Hence the efficiency is decreased.

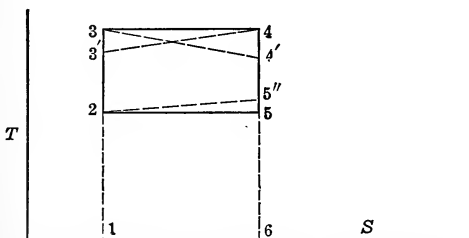

FIG. 21.—Conditions for maximum efficiency.

If the heat were removed on a line 5'2' of Fig. 21 this would cut down the work but would not effect the heat, hence the efficiency would be diminished in this case.

From the above it may be said that for a given range of temperature heat must be added or taken away at constant temperature if the **maximum efficiency** is to be obtained and since this efficiency is

$$1 - \frac{T_2}{T_1}$$

the values of T_2 and T_1 (the limiting temperatures of the range) are to be separated as much as possible.

An important point must be borne in mind. Although the

statement above is absolutely true, it does not follow that a cycle in which heat is added with a varying temperature finally reaching a high value may not be more efficient than one in which heat is added at a constant temperature of lower value. Such cycles may be made necessary by the nature of the medium used. This is shown in Fig. 22. 1234 is less efficient than 5678. What is meant is that given the highest and lowest possible temperatures of a cycle, the greatest efficiency would be obtained if all of the heat added were added at the highest temperature and all of the heat removed were abstracted at the lowest temperature.

Thus in Fig. 23 the efficiency of the steam engine with saturated steam is $\frac{abcd}{eabf}$ while that with superheated steam is $\frac{abb'c'd}{eabb'g}$. In the figure $\frac{abcd}{eabf}$ is practically equal to $\frac{abhc'd}{eahg}$ and by adding the

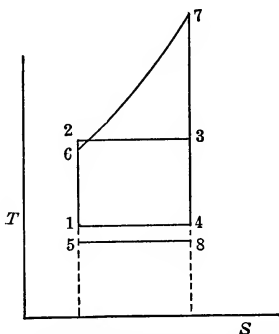

FIG. 22.—Cycle with varying temperature on heat line.

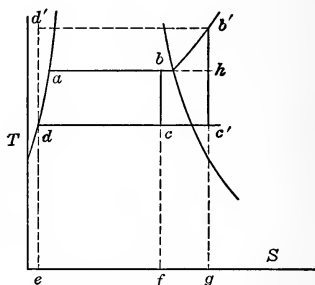

FIG. 23.—Steam engine cycles with saturated and superheated steam.

triangle $bb'h$ to numerator and denominator the expression for the superheated cycle is obtained. This addition having a greater effect on the numerator increases the efficiency. Hence the use of superheated steam, although the heat is not added at constant temperature, does increase the efficiency a slight amount. For other reasons than those mentioned here the use of superheated steam increases the efficiency of the engine. The efficiency would be increased by a greater amount if the heat could have been added on the dotted line $d'b'$. In this case the efficiency would have been

$$\frac{d'b'c'd}{ed'b'g}$$

In some machines as the steam turbine the indicated work cannot be obtained and in such a case the product $\eta_5 \times \eta_6$ only can be determined.

METHOD OF REPORTING PERFORMANCE OF ENGINES

Although the efficiency of an engine tells an exact story, for commercial reasons it is quite common to report the performance of a heat engine in pounds or cubic feet of substance required per indicated or brake horse-power hour. Thus pounds of steam per horse-power hour for an engine or turbine, cubic feet of standard gas per horse-power hour for a gas engine, coal per horse-power hour for a gas or steam engine have all been found in reports of tests. This data on the horse-power hour or kilowatt-hour basis is valuable for commercial reasons but because different gases and coals have different heating values, and steam at different pressures and qualities contains different amounts of heat, these statements are not definite until other data are known.

When coal is used in a boiler or producer the coal per unit of output depends on the efficiency of the boiler or producer as well as upon the engine. To separate the losses and find out just where losses occur and just what they are, it is always better to give the efficiency of the heat engine as a percentage using the heat supplied as the base. These other methods are valuable for commercial purposes and the quantities should be reported.

A method used in reporting the performance of pumps is by **duty**. This is the amount of useful work in foot-pounds per (a) 100 lbs. of coal, (b) 1000 lbs. of dry steam, or (c) per 1,000,000 B.t.u. The first two methods are not definite although the third method is exact. The duty by the third method, divided by 778,000,000, will give the overall efficiency.

Results of a number of tests will now be given:

HIGH-SPEED NON-CONDENSING ENGINE

I.h.p.	130	$\eta_1 = \frac{347.4 - 213}{347.4 + 460} = 16.7\%$
B.h.p.	120	$\eta_3 = \frac{1190 - 1078.5 + \frac{144}{778}(29.8 - 15)12.58}{1190 - 181.3}$
		$= 14.5\%$
Steam pressure ...	115.3 lbs. per sq. in. gauge	$\eta_2 = \frac{14.5}{16.7} = 86.7\%$

Barometer.....	14.7 lbs. per sq. in.	$\eta_5 = \frac{2546}{30.5[1190-181.3]} = 8.3\%$
Quality of steam...	1.00	$\eta_4 = \frac{8.3}{14.5} = 57.4$
Pressure at end of expansion...	15 lbs. per sq. in. gauge	$\eta_6 = \frac{120}{130} = 92.5\%$
Back pressure....	0.3 lb. per sq. in. gauge	
Steam per i. h.p. hr.	30.5 lbs.	
		B.t.u. per i.h.p.-min. = $\frac{42.42}{0.083} = 510$

HIGH-SPEED NON-CONDENSING COMPOUND ENGINE

I.h.p.....	130	$\eta_1 = 16.7\%$
B.h.p.....	115	$\eta_3 = 14.5\%$
Steam pressure....	115.3 lbs. per sq. in. gauge	$\eta_2 = 86.7\%$
Barometer.....	14.7 lbs. per sq. in.	$\eta_5 = \frac{2546}{21.5 \times [1190-181.3]} = 11.7\%$
Back pressure....	0.3 lbs. per sq. in. gauge	$\eta_4 = \frac{11.7}{14.5} = 81\%$
Pressure at end of expansion...	15 lbs. per sq. in. gauge	$\eta_6 = \frac{115}{130} = 88.5\%$
Quality of steam....	1.00	
Steam per i. h.p.-hr..	21.5 lbs.	
		B.t.u. per i.h.p.-min. = $\frac{42.42}{117} = 362$

LOCOMOBILE ENGINE

I.h.p.....	191	$\eta_1 = \frac{391+282-139}{391+282+460} = 47.2\%$
Kw. generator.....	121.5	$\eta_3 = \frac{1352-1002}{1352-107} = 28.1\%$
Steam pressure....	208 lbs. per sq. in. gauge	(Complete expansion.)
Feed Temperature...	132° F.	$\eta_2 = \frac{28.1}{38.3} = 59.7\%$
Barometer.....	14.7 lbs. per sq. in.	$\eta_5 = \frac{2546}{9.9[1352-107]} = 20.6\%$
Vacuum.....	11.9 lbs. per sq. in.	$\eta_4 = \frac{20.6}{28.1} = 73.4\%$
Degrees superheat..	282° F.	$\eta_6 \times \eta_7 = \frac{121.5}{191 \times 0.746} = 85.5\%$
Steam per i. h.p.-hr..	9.9 lbs.	Eff. of boiler = $\frac{8.28[1352-100]}{14099} = 73.6\%$
Steam per lb. coal...	8.28 lbs.	
Heat of coal.....	14,099 B.t.u. per lb.	
		B.t.u. per i.h.p.-min. = $\frac{42.42}{0.206} = 206$

PUMPING ENGINE

I.h.p.....	861.34	$\eta_1 = \frac{384.2 - 108}{384.2 + 460} = 32.7\%$
Del. h.p.....	839.8	$\eta_3 = \frac{1189 - 926 + \frac{144}{778}(4 - 1.2)67.8}{1189 - 76.0} = 26.7\%$
Steam pressure.....	190.8 lbs. per sq. in. gauge	$\eta_2 = \frac{26.7}{32.7} = 82\%$
Barometer.....	14.8 lbs. per sq. in.	$\eta_5 = \frac{2546}{10.37[1189 - 76]} = 22.1\%$
Back pressure.....	1.2 lbs. per sq. in. abs.	$\eta_4 = \frac{22.1}{26.7} = 82.8\%$
Pressure at end of expansion.....	4 lbs. per sq. in. abs.	$\eta_6 = \frac{839.8}{861.3} = 97.4\%$
Quality of steam....	0.99	
Steam per i.h.p.-hr..	10.37	
	B.t.u. per i. h.p.-min. =	$\frac{42.42}{0.221} = 192$
	Duty per million B.t.u. =	$778,000,000 \times 0.221 \times 0.974 = 167,000,000 \text{ ft.-lbs.}$

STEAM TURBINE

Kw.....	6257	$\eta_1 = \frac{549 - 76}{559 + 460} = 45.6\%$
Steam pressure.....	203.7 lbs. per sq. in. abs.	$\eta_3 = \frac{1290 - 879}{1290 - 44} = 33\%$
Superheat.....	165.5° F.	$\eta_2 = \frac{33}{45.6} = 72.5\%$
Barometer.....	29.92"	$\eta_5 = \frac{2546}{11.95 \times [1290 - 44] \times 0.746} = 22.9\%$
Back pressure.....	0.44 lbs. per sq. in. abs.	$\eta_4 = \frac{22.9}{33} = 69.5\%$
Steam per kw.-hr...	11.95 lb.	
	B.t.u. per kw.-min. =	$\frac{42.42}{0.746 \times 0.229} = 249$
	B.t.u. per elec. h.p.-min. =	$249 \times 0.746 = 186$

PRODUCER GAS ENGINE

I.h.p.....	579	$\eta_5 = \frac{2546}{0.738 \times 0.805 \times 14320} = 30\%$
B.h.p.....	483	$\eta_6 = \frac{483}{579} = 83.5\%$
Coal per i.h.p.-hr...	0.805	
Heating value of coal	14,320 B.t.u. per lb.	

Kind of coal. Bituminous

Efficiency of producer. 73.8%

$$\text{B.t.u. per i.h.p.-min.} = \frac{42.42}{0.30} = 141.4$$

$$\text{B.t.u. per b.h.p.-min.} = \frac{141.4}{0.835} = 169$$

BLAST-FURNACE GAS ENGINE

I.h.p. 775

$$\eta_s = \frac{2546}{110.5 \times 90.5} = 25.5\%$$

B.h.p. 565

$$\eta_6 = \frac{565}{775} = 73\%$$

Cu. ft. of gas per i.h.p.-hr. 90.5

Heat value of gas. 110.5 B.t.u. per cu. ft.

$$\text{B.t.u. per i.h.p.-min.} = \frac{42.42}{0.255} = 166$$

$$\text{B.t.u. per b.h.p.-min.} = \frac{166}{0.73} = 227$$

DIESEL OIL ENGINE

I.h.p. 523

$$\eta_s = \frac{2546}{0.37 \times 19270} = 35.8\%$$

B.h.p. 450

$$\eta_6 = \frac{450}{523} = 86\%$$

Oil per i.h.p.-hr. . 0.37 lb.

Heat value of oil. . 19,270 B.t.u. per lb.

$$\text{B.t.u. per i.h.p.-min.} = \frac{42.42}{0.358} = 118$$

$$\text{B.t.u. per b.h.p.-min.} = \frac{118}{0.83} = 143$$

RESULTS OF VARIOUS TESTS

Engine tested	B.t.u. per i.h.p.- min.	B.t.u. per b.h.p.- min.
110-h.p. Nurnberg gas engine on coke.	110	138
110-h.p. Nurnberg gas engine on anthracite coal. .	120	150
210-h.p. Guldner engine on illuminating gas.	100
600-h.p. Ehrhardt engine on coke-oven gas.	113	136
11,000-kw. Westinghouse turbine.	213
11,000-kw. Curtis turbine.	201
1,500-h.p. locomotive.	350
10,000-h.p. marine engine.	246
2,200-h.p. Corliss engine.	226
1,000-h.p. air-compressor engine.	169

TOPICS

Topic 1.—What is a heat engine? What is a cycle? What is the general expression for the efficiency of any cycle? What is the expression for the

efficiency of the Carnot cycle? What does this efficiency represent? Give the meaning of the terms: Carnot efficiency, type efficiency, theoretical efficiency, practical efficiency, actual thermal efficiency, mechanical efficiency and overall efficiency.

Topic 2.—Give the meaning of the symbols: η_1 , η_2 , η_3 , η_4 , η_5 , η_6 , η . Give the relations between these and the formulæ by which each is found. Tell the manner of determining the quantities entering into these formulæ.

Topic 3.—Give the conditions for maximum efficiency in a heat engine and show that although these conditions may not be fulfilled high efficiencies may be obtained. Are these high efficiencies as high as they would be were the conditions for maximum efficiency fulfilled? How are results of tests reported?

PROBLEMS

Problem 1.—An engine using 35 lbs. of steam per h.p.-hr. at 125 lbs. gauge pressure, $x = 0.98$, and with a back pressure of 2.5 lbs. gauge, has its consumption reduced to 30 lbs. when supplied with steam under the same pressure but superheated 245° F. The back pressure does not change. The barometer is 29.8 in. What is the per cent. saving, if any?

Problem 2.—A Corliss engine gives the following test results: i.h.p. = 135.6; b.h.p. = 126.0; steam per hour, 3406 lbs.; pressure at throttle valve by gauge, 135.6 lbs. per square inch; barometer, 14.68 lbs. per square inch; pressure at end of expansion by gauge, 20.5 lbs. per square inch; back pressure by gauge, 1.5 lbs. per square inch. Find the various efficiencies, η , η_6 , η_5 and η_1 .

Problem 3.—A Corliss condensing engine using steam at 174 lbs. gauge pressure with $x = 0.995$ and a vacuum of 27 in. with a barometer of 29.8 in. consumes 17.5 lbs. of steam per kw.-hr. output from generator. Find overall efficiency. By installing a low-pressure turbine and by reducing the vacuum to 28.5 in. and superheating the steam to 200° F. of superheat this consumption is made 13.8 lbs. of steam per kw.-hr. and the output of the plant has been increased 75 per cent. Is the change of value? Why?

Problem 4.—A pumping engine gives a delivered duty of 175,000,000 ft.-lbs. per 1,000,000 B.t.u. when supplied with steam at 165 lb. gauge pressure with $x = 1$ and a temperature of hot well of 105° F. How many pounds of steam are used per delivered horse-power hour? If the mechanical efficiency is 95 per cent., what is the steam consumption per i.h.p.-hour?

Problem 5.—A gas engine has an overall efficiency of 24 per cent. The heat lost in the jacket is 25 per cent. of that supplied by the gas. How much heat is added to the jacket water per hour if the delivered power is 565 kw.?

Problem 6.—The results of the test of a producer gas engine plant are as follows: Coal burned in 120 hr., 16,000 lbs.; heating value of coal, 14,450 B.t.u.; gas produced during test, 1,500,000 cu. ft.; heating value of gas, 120 B.t.u. per cubic foot; b.h.p., 120; i.h.p., 150; cooling water, 1,000,000 lbs.; temperature of inlet water 65° F., outlet water 110° F. Find the efficiency of the producer. Find the overall efficiency, η . Find the indicated efficiency, η_s . Find the heat removed by the jacket water. Find the heat per b.h.p.-hr., per b.h.p.-min., per i.h.p.-hour and per i.h.p.-min.

CHAPTER III

HEAT TRANSMISSION

The phenomenon of the transmission of heat through partitions is very important as it enters into the determination of the areas of radiators for heating systems; of the surface required in condensers, boilers, evaporators, intercoolers, and for many other engineering structures. Its consideration is important in finding the heat required for warming a building or the amount of refrigeration to keep a certain cold storage warehouse at a low temperature. The transmission of heat is complicated and although much experimentation has been done the exact laws are not completely determined. The following discussion is based on the works of various authors. The results of the authors have been arranged so as to give the student a working knowledge of this important part of applied thermodynamics.

To transmit heat from one body to another or from one part of a body to another it is necessary to have a **difference of temperature**. Having this, the heat may be transmitted by one or more of the three methods: **radiation**, **convection** and **conduction**. **Radiation** is the method of transmitting heat by vibrations of the ether. The hot body starts this vibration which is transmitted in all directions through the ether and until another body receives the vibration the energy is not sensible. As soon, however, as a body opaque to these vibrations is placed in the path it becomes heated. In **convection** heat is applied to some movable body and then this energy is conveyed by the actual movement of the body with its heat. In this method heat is carried by moving particles of matter. **Conduction** is the method by which heat travels from the hot portions of a body to another part which is colder. In this method it may be that the more violent vibrations of the particles of the hot portion of the body are gradually transmitted to those in less violent vibration (colder) or according to the later views of the constitution of matter it may be that more electrons are thrown off at higher

temperature vibrations and these gradually affect the vibrations of the atoms at the more remote but colder portions of the solid.

The laws of transmission by radiation are well known experimentally and theoretically. The **Stefan-Boltzmann Law** for the radiation from a black body is

$$Q = CF(T_1^4 - T_2^4) \quad (1)$$

Q = amount of heat per hour in B.t.u.

C = a constant = 1.6×10^{-9} .

F = area radiating heat, in square feet.

T_1 = absolute temperature in degrees F. of hot body.

T_2 = absolute temperature in degrees F. of cold body which must surround the hot body or which must include all rays issuing from the hot body.

It is to be remembered that the formula applies to black bodies and then only when the cold surface includes all rays from the hot body. If the surface subtends a solid angle ω when it should have subtended a solid angle of 2π or a hemisphere, the quantity

Q is found by multiplying (1) by $\frac{\omega}{2\pi}$.

The law of radiant energy has been under discussion from the time of Newton in 1690, who proposed a law proportional to the first power of the temperature, until 1879 when Stefan proposed that the law be of the form given in (1) basing his assumption on some experiments of Dulong and Petit, Tyndall and others. After some years (1884) Boltzmann proved that this form was correct theoretically. A black body has to be assumed since a colored body would reflect a certain amount of energy and thus the amount emanating would include this in addition to the amount radiated. For bodies which are not truly black (absorb all radiation falling on them) the law is approximately true. The nature of the surface has also an effect and this should be taken into account. Polished bodies will not radiate as much as rough surfaces.

The above law may for convenience be put in the form

$$Q = 1600 \left[\left(\frac{T_1}{1000} \right)^4 - \left(\frac{T_2}{1000} \right)^4 \right] \quad (2)$$

The above refers to a black body of perfect radiating power. The relative values of different surfaces by Lucke are given in the following table:

	Absorbing power
Porous carbon.....	1.00
Glass.....	0.90
Polished cast iron.....	0.25
Polished wrought iron.....	0.23
Polished steel.....	0.19
Polished brass.....	0.07
Hammered copper.....	0.07
Polished silver.....	0.03

The **transmission** of heat by pure **conduction** is a simple matter. The law for this is similar to that of the transmission of electric current. The flow of heat is proportional to the difference of temperature and the area of the substance and is inversely proportional to the length of path or thickness. Thus

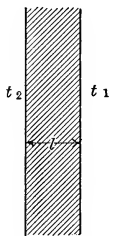

$$Q = \frac{CF}{l}(t_1 - t_2) \tag{3}$$

- Q = B.t.u. per hour.
- F = area in square feet.
- l = thickness in feet.
- t_1 = temperature at one side in degrees F.
- t_2 = temperature at one side in degrees F.

FIG. 24.—
Transmission surface.

C = coefficient of conduction in B.t.u. per hour per square foot per degree F. for 1 ft. thickness.

Values of C

$$C = C_0[1 + \alpha(t - 32)]$$

t = temperature in degrees F.

Substance	C_0	α	Substance	C_0	α
Air.....	0.03 to 0.012	0.0011	Cork powdered	0.03	-0.00012
Brass.....	53.5	0.0011	Glass.....	0.54	
Brick.....	0.46		Iron.....	48.5	
Carbon.....	0.8		Limestone.....	1.35	
Carbon dioxide	0.006		Masonry.....	0.46	
Cast iron.....	40.5	-0.00012	Sandstone.....	0.87	
Concrete.....	0.46		Steel soft.....	26.7	
Copper.....	239.0	0.00003	Water.....	0.292	
Cork board...	0.17		Wood.....	0.10	

The value of C for gases has been shown by Maxwell¹ to be given by

$$C = K\eta c_v$$

K = constant between 0.5 and 2.5.

η = coefficient of viscosity = the force between two planes separated by distance unity when one plane is moving with unit velocity relative to other.

c_v = specific heat at constant volume.

He also showed that C varies as the $\frac{3}{4}$ power of the absolute temperature.

Nusselt examined insulating materials and found that the conductivity of these substances increased as the absolute temperature.

The amount of **heat carried by convection** depends on the amount of substance involved, its specific heat and its temperature. This is simple to find but the amount of heat which can be abstracted from these particles by a given surface under given conditions is a complex matter and it is this method which will be considered throughout this chapter. This transfer of heat through partitions is the important one in most applications of heat.

When heat is transmitted through a surface as in a boiler or as in an indirect heating coil there must be films of substance on each side of the wall which prevent the passage of heat. Suppose, for instance, in a boiler where the temperature of the hot gases on one side is 1500° F. and the temperature of the water on the other is 325° F., the thickness of the steel tube is $\frac{1}{4}$ in. and that there are 4 lbs. of water evaporated per hour per square foot under these conditions.

The heat transmitted per square foot per hour

$$\begin{aligned} &= 4 \times r_{325} \\ &= 4 \times 889.8 = 3559.2. \end{aligned}$$

For the steel wall, by the law of conduction, there results:

$$3559.2 = \frac{26.7}{\frac{1}{4} \times \frac{1}{12}} \times (t_1 - t_2)$$

or
$$t_1 - t_2 = \frac{3559.2}{48 \times 26.7} = 2.78^\circ \text{ F.}$$

¹ Phil. Mag., 1860.

Now the difference between the water and the gas is 1175° F. and of this there is only a drop of 2.78° F. in the steel wall. A thin scale of $\frac{1}{100}$ in. on the water side and $\frac{1}{16}$ in. of soot on the gas side would account for considerable drop.

For the scale, C will be taken as 1.

$$t_2 - t'_2 = \frac{3559.2}{1200 \times 1} = 2.97^{\circ} \text{ F.}$$

For the soot, C will be taken as 0.1.

$$t'_1 - t_1 = \frac{3559.2}{16 \times 12 \times 0.1} = 185^{\circ} \text{ F.}$$

This accounts for 188° of the 1175° , showing that there must be still further resistance at the surface. This of course must be due to films of water and of gas. It is seen from the tables of values of C that water has about thirty times the value of C for air and gas, and hence there will probably be $\frac{1}{31}$ of 987° drop in the water film and $\frac{30}{31}$ of 987° drop in the gas film if these are the same thickness. The gas is probably less thick and if the water film is taken as three times the thickness of the gas film the drops in each will be approximately 90° in the water and 897° in the gas film.

The thicknesses to give these results are found below assuming C for water 0.292 and 0.009 for the gases. This is the mean of 0.006 and 0.012.

$$l_{water} = \frac{0.292 \times 90}{3559.2} \times 12 = 0.089 \text{ in.}$$

$$l_{gas} = \frac{0.009 \times 897}{3559.2} \times 12 = 0.0272 \text{ in.}$$

Thus it is seen that a film of small thickness on either side accounts for a great drop which must exist to explain the low conductive powers of the heating surface. If it were not for the films and scale the heat transmitted by the steel tube would be

$$Q = \frac{26.7}{\frac{1}{48}}(1500 - 325) = 1,505,000 \text{ B.t.u. per hour.}$$

This would mean an evaporation of 1690 lbs. of water per square foot of heating surface. Fig. 25 shows the **temperature gradient** across these surfaces. It appears from the figure and the calculation above that anything which would tend to decrease

the thickness of the films of water or gas would cut down the drop of temperature in these, putting a greater drop in the wall and so causing an increase in the heat transmitted. One method of doing this is to increase the velocity of the substance bringing heat up to the surface or taking heat from the surface. This has been tried and found true. The increase of velocity of the gas or water wipes some of the film away decreasing its thickness. This simple explanation is evident and shows why one would expect an increase in the heat transmitted, if either the velocity of the gas or the velocity of the water were increased across the surface transmitting the heat.

In October, 1909, Prof. W. E. Dalby presented to the Institute of Mechanical Engineers of Great Britain a paper on Heat Transmission, "the purpose of which was to place before the members of the Institution a general view of the work which has been done relating to the transmission of heat across boiler-heating surfaces." He has given this view and with it a list of 406 references to various papers dealing with this subject. They are listed chronologically, by Authors and by Subjects, and the student is referred to this paper for most of the literature on this important subject.

The fact that the velocity of the gases affected the rate of transmission was experimentally known as early as 1848 but there does not seem to be a statement of this until 1874 when Prof. Osborne Reynolds read a paper before the Literary and Philosophical Society of Manchester (Vol. xiv, 1874, p. 9)¹ "On the Extent and Action of the Heating Surface for Steam Boilers." In this very short paper of a few pages, Reynolds points out the importance of the subject. He states that the heat carried off from the gas is proportional to the internal diffusion of the fluid at or near the surface, that is, on the rate at which the particles

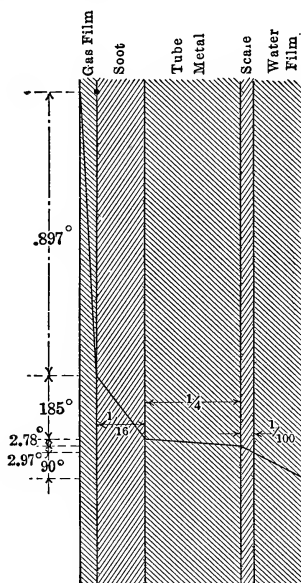

FIG. 25.—Temperature gradient.

¹ See also *The Steam Engine*, by John Perry, p. 594.

which give up their heat diffuse back into the hot gas. This according to him depends on two things:

1. The natural internal friction.
2. The eddies caused by visible motion which mix up the fluid and continually bring fresh particles into contact with the surface.

The first of these is independent of the velocity, and the second term is dependent on the velocity and density of the fluid, the heat transmitted at any point being

$$Q = At + Bmw t \quad (4)$$

where Q = heat per square foot per hour

A, B = constants

t = difference of temperature

m = density of substance, pounds per cubic foot

w = velocity along surface in feet per second.

He then discusses the quantities A and B and the way in which the heating surface may be of more value by an increase in velocity. He finally closes his paper with the hope of giving a further communication. He does not give the values of A and B .

In Reynolds' paper he gave no theoretical discussion nor derivation of his formula.

In 1898, Professor John Perry gave the following theoretical discussion to prove that transmission varied as the velocity:

In a thin film the number of molecules, n , entering the film per square foot of area is equal to the number leaving and the friction force developed by the axial momentum given up by the n molecules as they are arrested from velocity w will be given by

$$P(\text{per square foot}) \propto nw \quad (5)$$

Now since the kinetic energy is proportional to the temperature the change in the energy as the surface abstracts heat will be

$$Q \propto n(t - \theta) \quad (6)$$

t = original temperature of gas

θ = temperature at surface of pipe.

Eliminate n from (5) and (6)

$$Q \propto \frac{P}{w} (t - \theta) \quad (7)$$

It is known that the force of friction expressed in feet head when a fluid flows through a pipe is proportional to the square of the velocity w^2 . To change this to pounds per square foot it must be multiplied by the weight of 1 cu. ft., m , or

$$P \propto mw^2 \quad (8)$$

Hence (7) reduces to

$$Q = K'mw(t - \theta) \quad (9)$$

where

$$K' = \text{constant of equality.}$$

If now, Perry points out, there is a film of gas at the side of the surface of thickness b and conductivity K , there will really be a drop from t' to θ in the film and only a drop from t to t' in the gas so that

$$Q = K'mw(t - t') = \frac{K}{b}(t' - \theta)$$

$$t' = \frac{K'mwt + \frac{K}{b}\theta}{\frac{K}{b} + K'mw}$$

$$\text{or } Q = K'mw \left[t - \frac{K'mwt + \frac{K}{b}\theta}{\frac{K}{b} + K'mw} \right] = \frac{K'mw[t - \theta]}{1 + \frac{bK'mw}{K}} \quad (10)$$

If $\frac{K'}{1 + \frac{bK'mw}{K}}$ be called K'' the formula will be the same as

(9) with a different coefficient. If b decreases as w increases, which is probable, the product bw will be nearly constant and since K is large and m is small for most gases the denominator of the fraction will change little. Hence formula (9) is practically correct.

This equation of Perry and that of Reynolds may be changed by remembering that

$$M = mFw$$

where M = total weight per second in pounds

F = area of passage in square feet

w = velocity in feet per second

m = weight per cubic foot.

$$\text{Hence } \frac{M}{F} = mw$$

and

$$Q = At + B \frac{M}{F_i} t$$

$$Q = K'' \frac{M}{F} (t - \theta) \quad (10')$$

In Perry's formula the fact that P varied with m and w^2 might have been made to include the fact that P also varies inversely with the mean hydraulic depth, d_1 . Thus:

$$F \propto \frac{mw^2}{d_1}$$

The **hydraulic depth** or **hydraulic radius** is equal to the area of the cross section of a passage carrying a fluid divided by the perimeter of the cross section.

Hence

$$Q = K' \frac{mw}{d_1} (t - \theta) \quad (11)$$

This formula states that the smaller the tube the greater the heat transmission.

Dalby shows that in 1888 Ser and in 1897 Mollier gave formulæ in which the heat transmitted depended on the square root of the velocity of the gases along the tube, while Werner, Halliday, Carcanagues and Brillé show that it depends on the velocity. In 1897 T. E. Stanton investigated the "Passage of Heat between Metal Surfaces and Liquids in Contact with Them" (Phil. Trans. Roy-Soc., Vol. cxc A, p. 67) and showed that the transmission of heat varied with the velocity of water, and that although not stated in the paper in words, the formula of Reynolds is applicable to the liquid side as well as the gaseous side of a surface.

Prof. John T. Nicolson (Junior Institution of Engineers, Jan. 14, 1909, and London Engineering, Feb. 5, 1909, p. 194) and H. P. Jordan (Institution of Mech. Eng. of Great Britain, Dec. 1909, p. 1317) have each proposed formulæ for the transmission of heat which are somewhat similar to that of Reynolds, but in these as in the works of Stanton the coefficient of transmission depended on the temperature difference.

In general, the formula for the transmission of heat through a surface is

$$Q = K(t_1 - t_2)F$$

where Q = B.t.u. transmitted per hour
 t_1 = high temperature of fluid on one side in degrees F.
 t_2 = low temperature of fluid on other side in degrees F.
 F = surface in square feet
 K = coefficient of transmission in B.t.u. per hour per square foot per degree F.

According to Reynolds

$$K = A + B \frac{M}{F}, \text{ or } A + Bmw \quad (11')$$

According to Perry

$$K = K'' \frac{M}{F}, \text{ or } K''mw \quad (11'')$$

or later
$$K = K''' \frac{mw}{d_1} \quad (11''')$$

Finally it has been shown experimentally that K varies with the temperature difference. In the above three values of K it is seen that for a given tube with a given discharge the value of K would be constant, since $mw = \frac{M}{F}$.

This part does not depend on the variation of temperature along the pipe. The quantities A , B , K'' and K''' may however depend on temperature. In general the temperature along a surface changes from point to point so that $t_1 - t_2$ is a varying quantity and to apply the values of K determined by experiment it will be necessary to find what is the **mean difference** in temperature if the temperatures of the substance at the ends of the surface are given. The formula to be used for heat transfer is then

$$Q = (K \text{ for mean } \Delta t)(\text{Mean } \Delta t)F \quad (12)$$

MEAN TEMPERATURE DIFFERENCE

The question then arises: What is the value of mean Δt ? There is evidence to show that $K = \frac{K'}{(\Delta t)^n}$. To determine an expression for mean Δt for any value of n , two cases will have to be considered, one for any value of n except zero and the other for $n = 0$. The reason for this is the fact that $\int x^{n'} dx = \frac{1}{n'+1} x^{n'+1}$ for all values of n' except -1 . For $n' = -1$ the value of the

integral becomes $\log x$. To find the values of mean Δt the two cases are considered.

First case:

$K = \text{constant}$, or $n = 0$

$$dQ = K(t_{hx} - t_{cx})dF = -3600 M_h c_h dt_h = \pm 3600 M_c c_c dt_c \quad (13)$$

dQ = heat per hour in B.t.u. for surface of dF sq. ft.

K = heat per hour in B.t.u. per square foot per degree

t_{hx} = temperature in degrees F. in warm substance at point x

t_{cx} = temperature in degrees F. in cool substance at point x

M_c and M_h = weight of substances flowing per second

c_c and c_h = specific heat of substances in B.t.u. per pound per degree F.

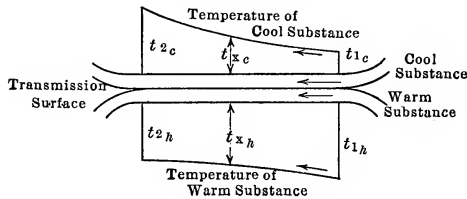

FIG. 26.—Parallel flow.

The minus sign before M_h is used because dt_h is negative as dF increases, measuring from the inlet end of the warm substance, where the temperature is t_{1h} , toward the outlet where the temperature is t_{2h} .

If the warm and cool substances flow in the same direction the arrangement is called a **parallel flow** arrangement (Fig. 26) and the temperature of the cold substance increases with dF hence dt_c is positive. With the warm substance flowing in the opposite direction from the flow of the cool substance the arrangement is called **counter flow** (Fig. 27). A minus sign is required before the dt_c as the temperature decreases with an increase of dF .

If t_{1c} is the temperature of the cool substance at the end corresponding to the entrance of the warm substance and t_{2c} is that of the cool substance at the point of exit of the warm substance, the following is true.

$$M_h c_h (t_{1h} - t_{2h}) = \mp M_c c_c (t_{1c} - t_{2c}) \quad (14)$$

The upper (minus) sign is for parallel flow and the lower (plus) sign is for counter flow in this equation. This of course assumes that all the heat leaving the warm substance goes into the cool substance and hence there is no radiation loss.

The following notation may be used:

$$\begin{aligned} t_{1h} - t_{1c} &= \Delta t_1 \\ t_{2h} - t_{2c} &= \Delta t_2 \end{aligned}$$

and from (13) it is seen that

$$M_h c_h (t_{1h} - t_{2h}) = \mp M_c c_c (t_{1c} - t_{2c}) \quad (15)$$

or

$$\begin{aligned} t_{2c} &= \frac{\pm M_h c_h}{M_c c_c} (t_{1h} - t_{2h}) + t_{1c} \\ \Delta t_x = t_{2h} - t_{2c} &= t_{2h} \pm \frac{M_h c_h}{M_c c_c} t_{2h} \mp \frac{M_h c_h}{M_c c_c} t_{1h} - t_{1c} \end{aligned}$$

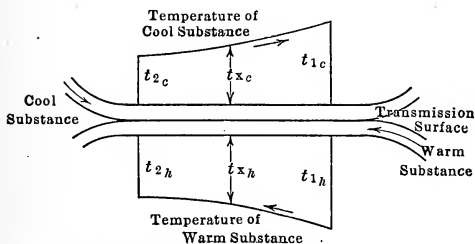

FIG. 27.—Counter current flow.

Now

$$d\Delta t_x = \left(1 \pm \frac{M_h c_h}{M_c c_c} \right) dt_{2h}$$

$$\therefore dt_{2h} = \frac{d\Delta t_x}{1 \pm \frac{M_h c_h}{M_c c_c}} \quad (16)$$

Substituting this in (13) gives

$$\begin{aligned} K\Delta t_x dF &= - \frac{3600 M_h c_h}{1 \pm \frac{M_h c_h}{M_c c_c}} d\Delta t_x \\ dF &= - \frac{3600}{K} \frac{M_h c_h}{1 \pm \frac{M_h c_h}{M_c c_c}} \frac{d\Delta t_x}{\Delta t_x} \\ F &= - \frac{3600}{K} \frac{M_h c_h}{1 \pm \frac{M_h c_h}{M_c c_c}} \log \Delta t \bigg|_{\Delta t_1}^{\Delta t_2} \quad (17) \end{aligned}$$

Now $H = K(\text{mean } \Delta t)F = 3600M_h c_h (t_1 - t_2)$

$$\text{mean } \Delta t = \frac{3600M_h c_h (t_1 - t_2)}{KF}$$

Substituting for F its value from (17)

$$\text{mean } \Delta t = \frac{M_h c_h (t_1 - t_2)}{\frac{M_h c_h}{1 \pm \frac{M_h c_h}{M_c c_c}} \log \frac{\Delta t_1}{\Delta t_2}} \quad (18)$$

From (14) $1 \pm \frac{M_h c_h}{M_c c_c} = 1 - \frac{t_{1c} - t_{2c}}{t_{1h} - t_{2h}}$

$$= \frac{t_{1h} - t_{1c} - (t_{2h} - t_{2c})}{t_{1h} - t_{2h}}$$

$$= \frac{\Delta t_1 - \Delta t_2}{t_{1h} - t_{2h}} \quad (18')$$

∴ Equation (18) reduces to

$$\text{mean } \Delta t = \frac{\Delta t_1 - \Delta t_2}{\log_e \frac{\Delta t_1}{\Delta t_2}} \quad (19)$$

This is independent of the direction of flow. The form of the expression is the same for parallel or counter current flow. It

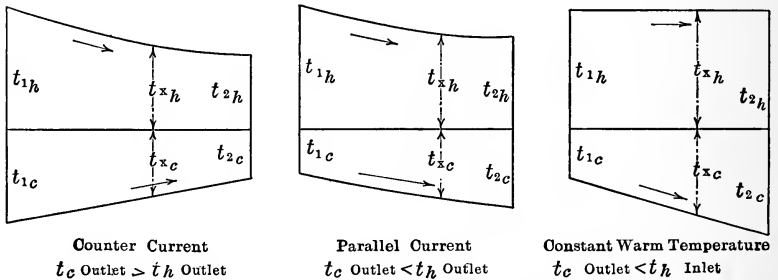

FIG. 28.—Temperature range for various arrangements.

will be found that for given temperature ranges the value of mean Δt will be greater for counter current flow. If T_h is the same for all of the surface, T_{1h} and T_{2h} are the same, and are so used in finding the Δt 's. If the lower temperature, as in the case of a boiler, is constant this formula takes care of that condition. If, however, both temperatures are constant as in the case of an evaporator then this formula reduces to $\frac{1}{2}$ which of course has the true value $T_h - T_c$. The temperature ranges are shown in Fig. 28.

With this value of mean Δt determined by the differences of temperature the value of Q for a given F could be determined as soon as K is known or F could be found for a given Q .

$$Q = K \times \text{mean } \Delta t \times F \quad (9)$$

This of course is true for the case in which K does not vary with Δt_x . The equation could be used to determine K if Q , F , and mean Δt are measured.

Second case:
$$K = \frac{K'}{(\Delta t_x)^n}$$

$$dQ = \frac{K'}{(\Delta t_x)^n} \Delta t_x dF = -3600 M_h c_h dt_{xh} = \pm 3600 M_c c_c dt_{xc} \quad (20)$$

By the method used in reducing (17) the following results

$$\int_0^F dF = \int_{\Delta t_1}^{\Delta t_2} - \frac{3600 M_h c_h}{K' \left(1 \pm \frac{M_h c_h}{M_c c_c}\right)} (\Delta t_x)^{n-1} d\Delta t_x \quad (21)$$

$$F = \frac{3600 M_h c_h}{K' \left(1 \pm \frac{M_h c_h}{M_c c_c}\right)} \frac{(\Delta t_1)^n - (\Delta t_2)^n}{n} \quad (22)$$

Now

$$F \frac{K'}{(\text{mean } \Delta t)^n} (\text{mean } \Delta t) = 3600 M_h c_h (t_{1h} - t_{2h})$$

$$(\text{mean } \Delta t)^{1-n} = \frac{3600 M_h c_h (t_{1h} - t_{2h})}{FK'}$$

Substituting from (22) and using (18')

$$(\text{mean } \Delta t)^{1-n} = \frac{M_h c_h (t_{1h} - t_{2h})}{\frac{M_h c_h}{\frac{\Delta t_1 - \Delta t_2}{t_{1h} - t_{2h}}} \frac{(\Delta t_1)^n - (\Delta t_2)^n}{n}}$$

$$\text{mean } \Delta t = \left[\frac{n(\Delta t_1 - \Delta t_2)}{(\Delta t_1)^n - (\Delta t_2)^n} \right]^{\frac{1}{1-n}} \quad (23)$$

$$Q = FK' (\text{mean } \Delta t)^{1-n} = FK' \left[\frac{n(\Delta t_1 - \Delta t_2)}{(\Delta t_1)^n - (\Delta t_2)^n} \right] \quad (24)$$

This equation gives the value of Q or F if the other is known in terms of K' which is not the transmission per degree per square foot per hour, but the constant which when multiplied by $(\text{mean } \Delta t)^{-n}$ gives the coefficient of transmission. The value of K' in (24) as in (12) may vary with any other quantities than temperature and if the value of K' for the conditions of the given

problem as to velocity, hydraulic radius or density be substituted the expression will be correct.

It is well to notice at this point that $\frac{\Delta t_1 + \Delta t_2}{2}$ gives the value of mean Δt within $\frac{1}{2}$ of 1 per cent. for any value of n if $\Delta t_1 - \Delta t_2$ is less than $\frac{1}{10}$ of $\frac{\Delta t_1 + \Delta t_2}{2}$. The formulæ

$$\text{mean } \Delta t = \left[\frac{n(\Delta t_1 - \Delta t_2)}{(\Delta t_1)^n - (\Delta t_2)^n} \right]^{\frac{1}{1-n}}$$

or

$$\text{mean } \Delta t = \frac{\Delta t_1 - \Delta t_2}{\log_e \frac{\Delta t_1}{\Delta t_2}}$$

need not be employed to find mean Δt if the change in Δt is slight. If however $\Delta t_1 - \Delta t_2$ is large compared with the mean Δt then the formulæ must be used. Having mean Δt for any given problem the heat or surface may be found by

$$Q = K' \times (\text{mean } \Delta t)^{1-n} \times F$$

$$\text{or } Q = K \times \text{mean } \Delta t \times F$$

depending on whether or not K varies with the temperature.

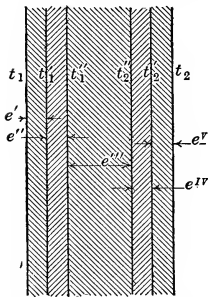

FIG. 29.—Transmission through various layers.

In Fig. 29 let the various temperatures at the division lines between the various layers be t_1^I , t_1^{II} , t_2^{II} and t_2^I while t_1 represents the temperature of the gas and t_2 represents the temperature of the water. The following results for 1 sq. ft. area:

$$\begin{aligned} Q &= K(t_1 - t_2) \\ &= \frac{c^I}{l^I} (t_1 - t_1^I) \\ &= \frac{c^{II}}{l^{II}} (t_1^I - t_1^{II}) \\ &= \frac{c^{III}}{l^{III}} (t_1^{II} - t_2^{II}) \\ &= \frac{c^{IV}}{l^{IV}} (t_2^{II} - t_2^I) \\ &= \frac{c^V}{l^V} (t_2^I - t_2) \end{aligned}$$

DETERMINATION OF K

The method of finding this K will now be considered.

where c^I = coefficient of heat conduction for gas film.
 c^{II} = coefficient of heat conduction for soot.
 c^{III} = coefficient of heat conduction for heating surface.
 c^{IV} = coefficient of heat conduction for scale.
 c^V = coefficient of heat conduction for water film.

$l^I, l^{II}, l^{III}, l^{IV}, l^V$ are the thicknesses in feet of the gas film, soot, heating surface, scale, and water film respectively.

$$\begin{aligned} \text{Now } Q \frac{l^I}{c^I} &= t_1 - t_1^I \\ Q \frac{l^{II}}{c^{II}} &= t_1^I - t_1^{II} \\ Q \frac{l^{III}}{c^{III}} &= t_1^{II} - t_2^{II} \\ Q \frac{l^{IV}}{c^{IV}} &= t_2^{II} - t_2^I \\ Q \frac{l^V}{c^V} &= t_2^I - t_2 \end{aligned}$$

$$\text{Adding these } Q \left[\frac{l^I}{c^I} + \frac{l^{II}}{c^{II}} + \frac{l^{III}}{c^{III}} + \frac{l^{IV}}{c^{IV}} + \frac{l^V}{c^V} \right] = t_1 - t_2$$

$$Q = \frac{1}{\frac{l^I}{c^I} + \frac{l^{II}}{c^{II}} + \frac{l^{III}}{c^{III}} + \frac{l^{IV}}{c^{IV}} + \frac{l^V}{c^V}} (t_1 - t_2) \quad (25)$$

$$\text{but } Q = K [t_1 - t_2]$$

$$\text{Hence } K \text{ (for combination)} = \frac{1}{\frac{l^I}{c^I} + \frac{l^{II}}{c^{II}} + \frac{l^{III}}{c^{III}} + \frac{l^{IV}}{c^{IV}} + \frac{l^V}{c^V}} \quad (26)$$

To apply this formula the thickness of the gas film l^I and of the water film l^V must be known. These of course depend on the velocity. The value of c^I for the gas and c^V for the water depend on the temperature of these and probably on their viscosity and on the hydraulic radius of the pipe. The values of the c 's for the solid materials vary with the temperature and hence the coefficient of conduction K for the combination will depend on the temperature.

In the case of the coefficient of transmission for walls and partitions of buildings, the air film usually depends on the

exposure and kind of surface hence for this formula, when applied to building calculations, the terms for the two films, $\frac{c^I}{l^I} (t_1 - t_1')$ and $\frac{c^V}{l^V} (t_2' - t_2)$, are replaced by $a_1(t_1 - t_1')$ and $a_2(t_2' - t_2)$. The quantities a are given by empirical formulæ which depend on the variable factors. $\frac{c}{l}$ is replaced by a . K becomes

$$K = \frac{1}{\frac{1}{a_1} + \frac{l^{II}}{c^{II}} + \frac{l^{III}}{c^{III}} + \frac{l^{IV}}{c^{IV}} + \frac{1}{a_2}} \quad (27)$$

The values of K for walls and partitions in most building problems are used as independent of temperature since the variation in temperature is not great in these cases.

To determine the value $\frac{c^I}{l^I}, \frac{c^V}{l^V}, a_1$ or a_2 is difficult in the case of transmission from gas to water, as in the case of boilers or intercoolers, from water to water in the case of sterilizers or from water to gas as in the case of indirect hot-water heaters. These terms are the largest and most effective terms entering into the value of K and for that reason the drop of temperature in the plate has been assumed to be zero. The coefficients at each surface have been determined and this determination has been made experimentally, putting the heat into the form

$$Q = K_g(t_1 - \theta) = K_w(\theta - t_2) \quad (28)$$

where θ is the mean temperature of the heating surface.

K_g is the coefficient of transmission on the gas side = $\frac{c^I}{l^I}$ = B.t.u. per square foot per hour per degree.

K_w is the coefficient of transmission on the water side = $\frac{c^V}{l^V}$.

t_1 = temperature of gas, t_2 = temperature of water.

The values of these K 's may depend on velocity, temperature or anything else but they are determined by experiment.

If it is desired to eliminate the temperature of the surface, this may be done by finding the value of K in

$$Q = K(t_1 - t_2)F$$

for which

$$K = \frac{1}{\frac{1}{K_g} + \frac{1}{K_w}} \quad (29)$$

This assumes that the drop in the heating surface and its scale is zero or is included in the drop in each film.

If the expression for K is assumed to be that of Perry,

$$K_g = K''_g m_g w_g = K''_g \frac{M_g}{F_g}$$

$$K_w = K''_w M_w w_w = K''_w \frac{M_w}{F_w}$$

These are the same as the values of Reynolds in which A has been made zero and B has been made K'' .

Nicolson suggests that 3 be used for K'' for gases and 6 be used for the K'' for water. These values are independent of the temperature and using them in (29) the following results:

$$\frac{1}{K} = \frac{1}{3} \frac{M_g}{F_g} + \frac{1}{6} \frac{M_w}{F_w} = \frac{1}{3m_g w_g} + \frac{1}{6m_w w_w} \quad (29')$$

$$= \left(\frac{6 + \frac{3m_g w_g}{m_w w_w}}{3} \frac{m_g w_g}{m_w w_w} \right) \frac{1}{6m_w w_w}$$

If $\frac{m_g w_g}{m_w w_w} = L = \frac{M_g F_w}{M_w F_g} \quad (30)$

$$\frac{1}{K} = \left(\frac{2+L}{L} \right) \frac{1}{6m_w w_w} = \left(\frac{2+L}{L} \right) \frac{L}{6m_g w_g}$$

$$K = \left(\frac{L}{2+L} \right) 6m_w w_w = \frac{6m_g w_g}{2+L} \quad (31)$$

$$= \left(\frac{6L}{2+L} \right) \frac{M_w}{F_w} = \left(\frac{6}{2+L} \right) \frac{M_g}{F_g} \quad (32)$$

In (31) or (32) K is expressed in terms of water or gas conditions and of the quantity L which is the ratio of conditions of flow of gas to that of water.

It will be remembered that for a perfect gas $m = \frac{p}{BT}$ and this may be used to find m for any gas.

For different values of L the values of K are given by the table below.

L	K
2.0	3.00 $m_w w_w$ or 1.50 $m_g w_g$
1.0	2.00 $m_w w_w$ or 2.00 $m_g w_g$
0.5	1.20 $m_w w_w$ or 2.40 $m_g w_g$
0.2	0.55 $m_w w_w$ or 2.73 $m_g w_g$
0.1	0.29 $m_w w_w$ or 2.86 $m_g w_g$
0.01	0.03 $m_w w_w$ or 2.99 $m_g w_g$
0.0	0.0 $m_w w_w$ or 3.00 $m_g w_g$

Since air or flue gas at 580° F. weighs about $\frac{1}{25}$ lb. per cubic foot and a common velocity is 100 ft. per second and hot water which weighs about 60 lb. per cubic foot may move with a velocity of 12 ft. per second, a common value of L will be given by

$$L = \frac{m_g w_g}{m_w w_w} = \frac{\frac{1}{25} \times 100}{60 \times 12} = \frac{1}{180} = 0.006$$

and
$$K = 3.00 m_g w_g \quad (33)$$

Since K is assumed independent of t ,

$$Q = 3.00 m_g w_g \frac{\Delta t_1 - \Delta t_2}{\log_e \frac{\Delta t_1}{\Delta t_2}} F \quad (34)$$

Before leaving this formula it may be well to point out that Nicolson also suggests bringing into this expression the different diameters of the surface in contact with the gas and the water.

Thus
$$dQ = K_g m_g w_g (t_1 - \theta) \pi d_g dx = K_w m_w w_w (\theta - t_2) \pi d_w dx \quad (35)$$

$$\frac{\theta - t_2}{t_1 - \theta} = \frac{K_g m_g w_g d_g}{K_w m_w w_w d_w} = L' \quad (36)$$

$$\theta = \frac{t_2}{1 + L'} + \frac{L'}{1 + L'} t_1$$

$$t_1 - \theta = \frac{1}{1 + L'} (t_1 - t_2) \quad (37)$$

$$\theta - t_2 = \frac{L'}{1 + L'} (t_1 - t_2) \quad (38)$$

If $K_g m_g w_g$ is known it may be used for the determination of the heat, of L' and $(t_1 - t_2)$ or their mean values are known.

Thus
$$Q = K_g m_g w_g \frac{1}{1 + L'} \text{ mean } (t_1 - t_2) F$$

This can be done for the water side

Hence
$$K = K_g m_g w_g \frac{1}{1 + L'}$$

since
$$L' = \frac{1}{2} L \frac{d_g}{d_w}$$

and
$$K_g = 3 \text{ according to Nicolson.}$$

This result is similar to equation (31) except for the term $\frac{d_g}{d_w}$.

The equations (37) and (38) enable one to compute the heat transfer from either the water or the gas side.

The value of 2.75 for the coefficient of (33) is recommended by Nicolson.

The values of $K_g = 3$ for gas have been determined by Prof. Nicolson from seven sets of experiments in which the temperatures of the water and air were varied. This variation however was not sufficient to show the variation of K_g with temperature. The values obtained varied from 2.84 to 3.11 but Nicolson did not attempt to show the variation of this with temperature. The value of $K_w = 6$ was determined from Stanton's experiments in which water only was used. In this Stanton points out that K_w does vary with the temperature. Nicolson proceeds further to show that K varies with temperature, using superheated steam to transmit heat to air or water and using heated air to transmit heat to water. In addition to these experiments Nicolson discussed certain boiler tests to determine constants for a formula. He uses the formula

$$Q = K(T - \theta)F \quad (39)$$

and shows that

$$K = \left[\frac{\phi}{200} + \frac{1}{40} \sqrt{\phi} \left(1 + \frac{1}{d_1} \right) m_g w_g \right]. \quad (40)$$

Q = B.t.u. per hour.

T = mean temperature of gas along flue in degrees F.

θ = mean temperature of flue in degrees F. = temperature of steam.

$$\phi = \frac{1}{2}(T + \theta).$$

d_1 = hydraulic mean depth of flue in inches.

$$= \frac{\text{area}}{\text{perimeter}} = \frac{\text{diam.}}{4}.$$

m_g = weight of 1 cu. ft. of gas in pounds.

w_g = velocity of gas in feet per second.

F = area in square feet of surface on gas side.

M = total weight per second.

$$m_g w_g = \frac{M}{F}.$$

This formula is worked out from experiment. It is correct in form if K is of the form

$$K = A\Delta t + B\Delta t^{1/2}.$$

Q will be of the form

$$Q = F[A\Delta t_1\Delta t_2 + \frac{2}{3}B(\Delta t_1^{1/2} + \Delta t_2^{1/2})\Delta t_1^{1/2}\Delta t_2^{1/2}]$$

or since $\Delta t_1\Delta t_2$ may be written as Δt^2 and $\frac{1}{2}(\Delta t_1^{1/2} + \Delta t_2^{1/2})$ may be written as $\Delta t^{1/2}$. This reduced to

$$Q = A[\Delta t + \frac{4}{3}B\Delta t^{1/2}]\Delta t F$$

This is the form of (39) with the value of K substituted when the value of Δt is inserted.

These are the same and hence the formula is correct in form. If the constants are worked out to fit certain conditions, it will lead to correct results when applied to such conditions.

H. P. Jordan in the Transactions of the Institution of Mechanical Engineers for Dec., 1909, p. 1317 gives the formula in the form

$$Q = 3600 \left\{ 0.0015 + \left[0.000506 - 0.00045d_1 + 0.00000165 \left(\frac{T + \theta}{2} \right) \right] \frac{M_g}{F_g} \right\} (T - \theta) F \quad (41)$$

This is also seen to be of correct form as is the case of Nicolson's formula. For the range of the experiments the results are usable. Unfortunately these two formulæ do not yield the same results for various problems. For instance, using a problem given by Nicolson the differences may be seen.

In a Lancashire boiler the flue is 36 in.; 400 lbs. of coal are burned per hour with 24 lbs. of air per pound of coal. The gases leave the fire at 2200° F. and at the end of the flue they are 900° F. The steam temperature is 350° F.

$$T = \frac{2200 + 900}{2} = 1550^\circ \text{ F.}$$

$$\theta = 350^\circ \text{ F. assumed}$$

$$\phi = \frac{1550 + 350}{2} = 950^\circ \text{ F.}$$

$$F_g = \frac{9}{4}\pi = 7$$

$$m_g w_v = \frac{M_g}{F_g} = \frac{400 \times 25}{3600 \times 7} = 0.4$$

$$d_1 = \frac{36}{4} = 9$$

By (40):

$$K = \left[\frac{950}{200} + \frac{1}{40} \sqrt{950} \times 1.11 \times 0.4 \right] = 4.75 + 0.34 = 5.09$$

By (41):

$$K = 3600 \left\{ 0.0015 + [0.000506 - 0.00045 \times 9 + 0.00000165 (950)] 0.4 \right\} = 2.64$$

Using the method first proposed by Nicolson and assuming a velocity of $\frac{1}{2}$ ft. per second for the water,

$$\text{By (30):} \quad L = \frac{\frac{M_g}{F_g}}{m_w w_w} = \frac{0.4}{60 \times \frac{1}{2}} = 0.013$$

$$\text{By (32):} \quad K = \left(\frac{6}{2 + 0.013} \right) 0.4 = 1.2$$

This third method is evidently incorrect due to the temperature effect and there is a great discrepancy between the results from the formula of Nicolson and that of Jordan.

If these had been used for a mean temperature of 950° but with 4 in. diameter

$$\text{By (40):} \quad K = 4.75 + 0.61 = 5.36.$$

$$\text{By (41):} \quad K = 7.5$$

For $\frac{T + \theta}{2} = 300$ and for a number of 4-in. pipes of same area the results would have been as follows:

$$\begin{aligned} \text{By (40):} \quad K &= \frac{300}{200} + \frac{1}{40} \sqrt{300} \times 2 \times 0.4 \\ &= 1.5 + 0.346 = 1.8 \end{aligned}$$

By (41):

$$\begin{aligned} K &= 3600 \left\{ 0.0015 + [0.000506 - 0.00045 \times 1 + \right. \\ &\quad \left. 0.00000165 \times 300] 04 \right\}. \\ &= 3600 [0.00172] = 6.2 \end{aligned}$$

There is no change in the third method, K being 1.2 as before. This is more nearly the value 1.8 which is for temperatures near the values used in the experiments. The Jordan formula is reduced from a large number of experiments and in none of them does K fall below 4.5.

The formula of Nicolson does not agree with that of Jordan and apparently the reason for this may be said to be due to the fact that Nicolson's formula has been derived for large flues with high temperatures and Jordan's has been derived from small flues and for mean temperatures of 300° . Hence it would be well to restrict these to the conditions from which they were derived. The simpler formula for K is evidently in error on account of the effect of temperature. The wide variations make it necessary to compare the results to be obtained from other experiments.

H. Kreisinger and W. T. Ray in Bulletin 18 of the Bureau of Mines, U. S. Dept. of Interior, on the Transmission of Heat into Steam Boilers, have shown that the quantity of heat from hot gas to hot water varies directly with the velocity and with the temperature to some power. The efficiency of the heat transmission increases with the decrease of diameter of tube.

Wilhelm Nusselt (Mit. über Forschungsarbeiten, Heft 89) in his article on the transfer of heat in tubes has reduced the theoretical form for K with an empirical constant for the value of K in the formula

$$\begin{aligned} Q &= KF \frac{\Delta t_1 - \Delta t_2}{\log_e \frac{\Delta t_1}{\Delta t_2}} \\ K &= 15.90 \frac{\lambda_{wall}}{d^{0.214}} \left(\frac{wC_p}{\lambda} \right)^{0.786} \end{aligned} \quad (42)$$

in greater calories per hour per square meter per degree C.

λ_{wall} = coefficient of conduction of gases at wall temperature, greater calories per square meter per hour per degree for 1 meter thickness.

w = velocity in meters per second.

C_p = specific heat at constant pressure for 1 cubic meter at condition of gas in flue.

λ = coef. of conduction of gases at mean temperature of tube.

d = diam. of tube in meters.

This may be thrown into a different form since

$$C_p = c_p \frac{p}{BT}$$

c_p = specific heat of 1 kg. of gas.

(42) then becomes

$$K = 15.90 \frac{\lambda_{wall}}{d^{0.214}} \left(\frac{wpc_p}{\lambda BT} \right)^{0.786} \quad (42')$$

To change this to K in B.t.u. per square foot per hour per degree the same factor 15.90 is used when the terms have the following meaning:

λ_{wall} = coef. of conduction of gas at wall temperature of tube in B.t.u. per hour per square foot per degree F for 1 ft. thickness.

w = velocity in feet per second.

C_p = specific heat at constant pressure for 1 cu. ft. of gas under conditions in tube.

λ = coef. of conduction of gas at temp. in tube.

d = diameter in feet.

The values of λ for the different gases are given below, quoted from Nusselt:

	French	English
Air	$0.01894(1 + 228 \times 10^{-5}t)$	$0.01287[1 + 127 \times 10^{-5}(t - 32)]$
CO ₂	$0.01213(1 + 385 \times 10^{-5}t)$	$0.00814[1 + 215 \times 10^{-5}(t - 32)]$
Steam	$0.0192(1 + 434 \times 10^{-5}t)$	$0.01288[1 + 241 \times 10^{-5}(t - 32)]$

Illuminating Gas

$$0.0506(1 + 300 \times 10^{-5}t). \quad 0.03390[1 + 167 \times 10^{-5}(t - 32)]$$

For a 4-in. pipe with 1500° F. gas and a wall at 400° F. with a

velocity of 50 ft. per second, and assuming gas to be a mean between air and CO₂, the following results:

$$\lambda = 0.01050[1 + 171 \times 10^{-5}(1500 - 32)] = 0.0371$$

$$\lambda_{wall} = 0.01050[1 + 171 \times 10^{-5}(400 - 32)] = 0.0171$$

$$C_p = 0.24 \times \frac{2116}{53.37 \times 1960} = 0.0049$$

$$K = 15.90 \frac{0.0171}{(\frac{1}{3})^{0.214}} \left(\frac{50 \times 0.0049}{0.0371} \right)^{0.786}$$

$$= 15.90 \times 0.0171 \times 1.265 \times 5.55$$

$$= 1.91$$

For a 36-in. flue for the mean temperature of 1550° F. and a wall temperature of 350° F. with $m_g w_g = 0.4$ the following results:

$$w_g m_g C_p = w_g C_p$$

$$\lambda_{wall} = 0.0105[1 + 171 \times 10^{-5} \times 318] = 0.0162$$

$$= 0.0105[1 + 171 \times 10^{-5} \times 1518] = 0.0377$$

$$K = 15.90 \frac{0.0162}{3^{0.214}} \left(\frac{0.24 \times 0.4}{0.0377} \right)^{0.786}$$

$$= \frac{15.90 \times 0.0162}{1.266} \times 2.2 = 0.448$$

For a 4-in. pipe for 1550° F. for gas and 350° F. for wall with $w_g m_g = 0.4$, the result is

$$K = 15.90 \frac{0.0162}{(\frac{1}{3})^{0.214}} \left(\frac{0.24 \times 0.4}{0.0377} \right)^{0.786}$$

$$= 15.90 \times 0.0162 \times 1.266 \times 2.2 = 0.716$$

These do not check with results of Nicolson nor Jordan for high temperatures, and of course, since based on experiments in which the temperature did not rise to such high values it should not be used in such cases. The formula has been computed for values of Δt of about 20° C. to 80° C.

In 1914, F. E. McMullen performed a large number of experiments in the Mechanical Engineering Laboratory of the Rensselaer Polytechnic Institute on the transmission of heat from hot air to water through brass and steel pipes. The velocity of the water was varied from 1 to 8 ft. per second, that of the air from 2 to 17 ft. per second. The brass pipes were of $\frac{3}{8}$ -in. and $\frac{5}{8}$ -in. outside diameter and the steel pipe was of $\frac{5}{8}$ -in. diameter. The mean

temperature difference was as much as 300° F. The results of this series of experiments showed that K varied inversely as $\Delta t^{1/8}$ and directly with the density of the air and the velocities of the water and gas. The formula becomes

$$Q = K(\text{mean } \Delta t)F \quad (43)$$

$$K = \frac{126m(w_a - 1.75)^{0.4}w_w^{1/8}}{(\text{mean } \Delta t)^{1/8}} \quad (44)$$

or

$$Q = K'(\text{mean } \Delta t)^{3/8}F$$

$$K' = 126m(w_a - 1.75)^{0.4}w_w^{1/8} \quad (45)$$

m = weight of 1 cu. ft. of air at mean temperature in

$$\text{pounds} = \frac{p}{BT}$$

w_a = velocity of air in feet per second.

w_w = velocity of water in feet per second.

$$(\text{mean } \Delta t) = \left(\frac{1/3[\Delta t_1 - \Delta t_2]}{\Delta t_1^{1/8} - \Delta t_2^{1/8}} \right)^{3/8} \text{ or } \frac{\Delta t_1 + \Delta t_2}{2} \quad (46)$$

if

$$\Delta t_1 - \Delta t_2 < \frac{1}{10} \left(\frac{\Delta t_1 + \Delta t_2}{2} \right)$$

From the above discussion of problems it is suggested that Nicolson's second formula be used for boiler problems; that Jordan's, Nusselt's and the Rensselaer formula be used for air coolers and heaters where mean Δt is about 300° F.

STEAM CONDENSERS

For transmission of heat through condenser tubes a reference is made to the work of G. A. Orrok, A. S. M. E. Transactions, Vol. xxxii, p. 1138. In this he shows that the constants of heat transmission from the steam to the water depends on the temperature difference to the $1/8$ power, on the square root of the velocity of the water, on the square of the steam richness, on the material and its cleanness. In his formula

$$Q = K(\text{mean } \Delta t)F = K''(\text{mean } \Delta t)^{7/8}F \quad (47)$$

$$K = \frac{K' a \rho^2 \mu \sqrt{w_w}}{(\text{mean } \Delta t)^{1/8}} \quad (48)$$

$$(\text{mean } \Delta t) = \left[\frac{1/8(\Delta t_1 - \Delta t_2)}{\Delta t_1^{1/8} - \Delta t_2^{1/8}} \right]^{3/8} \quad (49)$$

Q = B.t.u. per hour.

F = square feet of surface.

K = B.t.u. per square foot per hour per degree.

K' = 630.

a = cleanness factor, 1 to 0.5.

ρ = steam richness factor = $\frac{p_s}{p_t}$, where p_s is the pressure corresponding to temperature of steam in condenser and p_t = actual pressure in condenser measured in any units.

w_w = velocity of water in feet per second.

μ = materials factor = 1.00 for copper, 0.98 for admiralty metal, 0.87 for aluminum bronze, 0.80 for cupro nickel, 0.79 for tin, 0.75 for monel metal, and 0.74 for Shelby steel.

The student is also referred to Orrok's article for a bibliography of heat transmission for condensers.

AMMONIA CONDENSERS

In regard to **ammonia condensers** this formula should apply, but experimental results reported in the Transactions of the American Society of Refrigerating Engineers for 1907 seem to indicate a much lower result. This is given by a curve in which K for double-pipe condensers is given by

$$K = 130\sqrt{w_w} \quad (50)$$

w_w = velocity of water in feet per second

and

$$Q = K(\text{mean } \Delta t)F$$

$$(\text{mean } \Delta t) = \frac{\Delta t_1 - \Delta t_2}{\log_e \frac{\Delta t_1}{\Delta t_2}}$$

BRINE COILS

For brine cooling in double pipes the value of K seems to be given by

$$K = 84w_b$$

EVAPORATORS AND FEED-WATER HEATERS

The formula of Orrok should be applicable to the **heating and boiling of water** by steam as in **evaporators** and **feed-water**

heaters. The constants and values have been determined for various steam pressures and for that reason they should be applicable. However this may be, two formulæ recommended by Hausbrand will also be mentioned.

One of the formulæ quoted is that due to Mollier from Hagemann's experiments reduced to English units:

$$K = 10 + \left\{ 110 + 0.6 \left(t_s + \frac{t_1 + t_2}{2} \right) \right\} \sqrt{w_w} \quad (51)$$

t_s = temperature of steam in degrees F.

t_1 = temperature of liquid at entrance in degrees F.

t_2 = temperature of liquid at exit in degrees F.

The formula which Hausbrand recommends for the **transmission of heat from steam to water which is boiling** is that due to Jelinek's experiments. When reduced to English units it becomes

$$K = \frac{1270}{\sqrt{dl}} \quad (52)$$

d = diameter of tube in feet.

l = length of tube in feet.

In the above formula the material is copper and steam is on the inside. This formula may be correct for such apparatus in which there is a low velocity of the liquid. This is the only reason for such a formula applying, as all experiments show that the heat varies with the velocity of the liquid. For wrought iron 0.75 of the above values are to be used, 0.5 for cast iron and 0.45 for lead. In evaporators with **dilute solutions** of 15 per cent. solid matter in solution the transmission is decreased by about 15 per cent. of the above for clean water while, with **thick viscous liquids**, K is about one-third of that given above.

HEAT FROM LIQUIDS TO LIQUIDS

The coefficient of transmission from a liquid to a liquid may be found from the formula (29') given by Nicolson in which the constant 6 is used in each term.

$$\frac{1}{K} = \frac{1}{6m_w w_w} + \frac{1}{6m_w w_w} = \frac{1}{3m_w w_w} \quad (53)$$

Hausbrand gives the following equation for the coefficient from one liquid to another through brass and copper walls.

$$K = \frac{300}{\frac{1}{1 + 6\sqrt{w_1}} + \frac{1}{1 + 6\sqrt{w_2}}} \quad (54)$$

This refers to greater calories per square meter per degree C for velocities in meters per second and was calculated by Mollier from Joule's researches. Hausbrand suggests that 66 per cent. of the value of K be used for practical purposes. To change this to English units the following calculations are made where K_f refers to French units and K_e to English:

$$K_f = K_e \left(\frac{39.37}{12} \right)^2 \times \frac{9}{5} \times \frac{1}{2.2 \times \frac{9}{5}} = 4.9K_e$$

$$w_f = w_e \times \frac{12}{39.37} = \frac{w_e}{3.28}$$

$$K = \frac{\frac{300}{4.9}}{\frac{1}{1 + 6\sqrt{\frac{w_1}{3.28}}} + \frac{1}{1 + 6\sqrt{\frac{w_2}{3.28}}}} = \frac{61.2}{\frac{1}{1 + 3.31\sqrt{w_1}} + \frac{1}{1 + 3.31\sqrt{w_2}}} = \frac{60}{\frac{1}{1 + 1\frac{1}{3}\sqrt{w_1}} + \frac{1}{1 + 1\frac{1}{3}\sqrt{w_2}}} \quad (55)$$

These two formulæ do not give the same results and the later one is recommended for general use.

FACTOR OF SAFETY

In all of the above expressions for transmission it would be well to reduce the quantity by $\frac{1}{4}$ to have an excess of surface, or what would be the same thing increase the surface by 33 per cent. in finding the area required in a problem.

RADIATORS

The coefficient of transmission for **direct radiators** for heating varies with conditions of the surface and the type of radiators.

Carpenter quotes tests varying from 1.23 to 1.97 while Rietschel gives values of K varying from 0.51 to 2.65. A value of K of 1.8 will be used as an average for the computation of the heat transmitted for all types of direct radiators. This gives for such

$$Q = 1.8(t_s - t_a)F \quad (56)$$

Q = B.t.u. per hour.

F = square feet of surface.

t_s = temperature of steam or water in degrees F.

t_a = temperature of room in degrees F.

For **indirect heaters** the formula

$$Q = K \left(t_s - \frac{t_1 + t_2}{2} \right) F$$

may be used in which

$$K = 2 + 1.75\sqrt{w_a}$$

w_a = velocity of air across surface in feet per second.

t_1 = temperature of air at inlet in degrees F.

t_2 = temperature of air at outlet in degrees F.

t_s = temperature of steam in degrees F.

Experiments have been made and plotted for the determination of the **transmission of heat** and the **resultant air temperatures** obtained with **coils and cast-iron radiators** and these are to be resorted to rather than formulæ because the resultant temperature is dependent on the velocity and the temperature of the entering air and steam. Since in most problems low pressure steam is used the curves constructed from data of the American Radiator Co. and of the Buffalo Forge Co. are given, the first for a cast-iron pin radiator known as a **Vento Heater** and the second for the sections of **pipe coils**, each section being four pipes deep. The curves of Figs. 30 and 32 give the resultant air temperatures when air at zero degrees enters the **indirect heater** and passes over one, two, three, four, five, six, seven or eight sections at different velocities. The velocities are found by finding the volume of the air at 70° F. and then computing the velocity by dividing this volume by the clear area through which the air passes. Thus the velocity to be used for the curve is not the actual velocity at entrance or exit but is that occurring when the temperature of the air is 70° F.

The curves of Figs. 31 and 33 are those giving the average B.t.u.

per square or lineal foot of the total heater under the conditions given. It will be seen that as the velocity increases the final

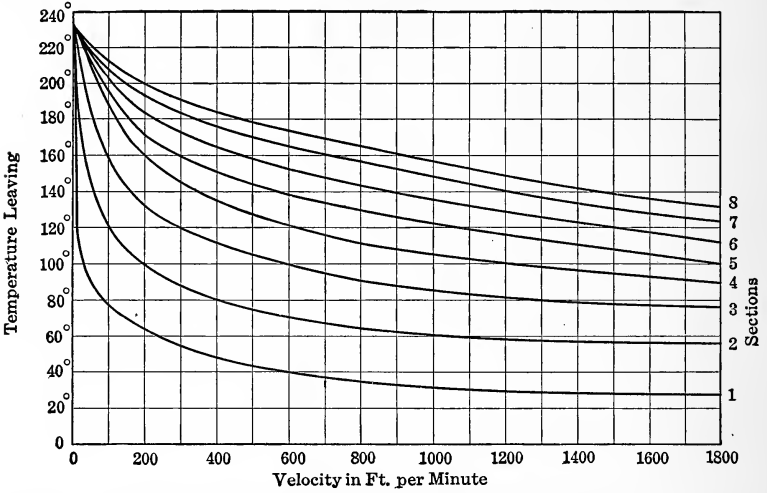

FIG. 30.—Temperature of air leaving Vento Heater with air at 0° F. and velocity at 70° F. Steam at 5 lbs. gauge pressure.

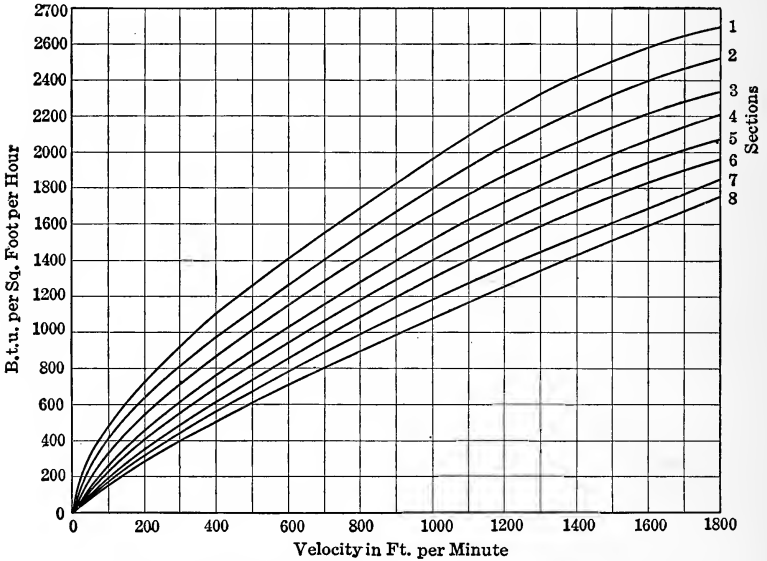

FIG. 31.—Heat transmitted per sq. ft. of Vento Heater with 5 lbs. steam and air entering at 0° F. Velocity at 70° F.

temperature of the air falls but that the heat transmitted per square foot increases, due to the lower final temperature and the

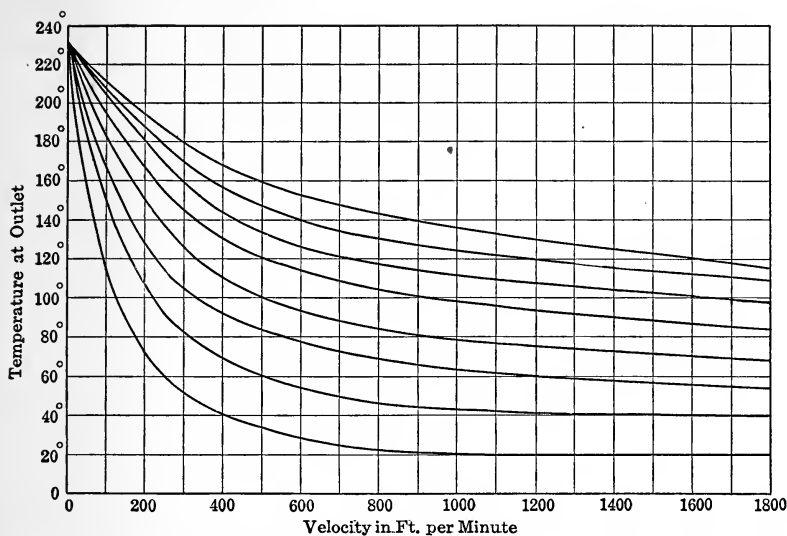

FIG. 32.—Temperature of outlet from sectional heaters of four coils each, with air entering at 0° F. Steam at 5 lbs. gauge pressure. Velocity at 70° F.

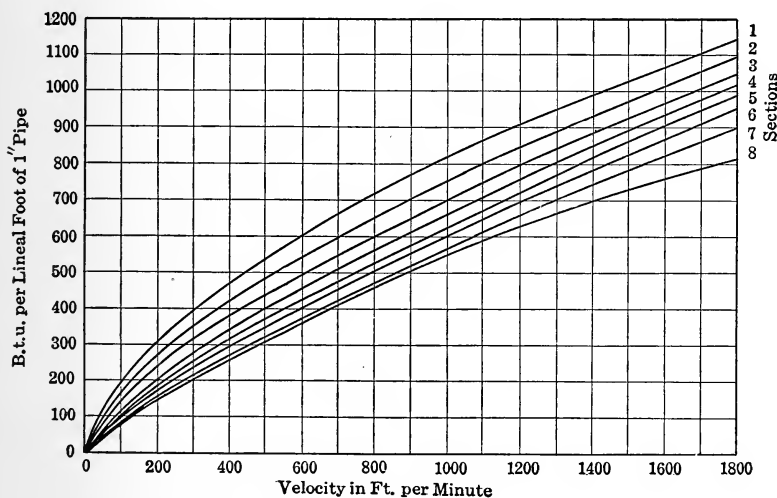

FIG. 33.—Heat transmitted per lineal foot of 1 in. pipe for 4 row sections of coil heaters with 5 lbs. steam and air entering at 0° F. Velocity at 70° F.

higher velocity. As the number of sections is increased the final temperature rises by decreasing increments since the temperature difference between the steam and air is less for the successive sections, decreasing the heat transmitted, and the heat per square foot is less for the same reason.

Since air often is supplied at a higher temperature than 0° F. it is well to understand how such curves may be used for these conditions. Suppose air at 40° F. and 600 ft. velocity is to be heated in Vento heaters. It will be seen that one section would have been required to give this temperature and if a temperature of 100° F. had been desired three sections would be required to do this with zero air. The first section would bring the air to 40° F. so that only two sections will be required for 40° air. Now with zero air one section at 600 ft. velocity will transmit 1450 B.t.u. per hour per square foot and three sections will transmit 1150 B.t.u. per square foot per hour. The amount transmitted by the last two sections will therefore be

$$1150 \times 3 - 1450 = 2000$$

or
$$\frac{2000}{2} = 1000 \text{ B.t.u. per square foot.}$$

If two sections had 0° F. air supplied the curves show that 1275 B.t.u. per hour per square foot would have been transmitted but in this case, the entering air being at 40° F., there is a smaller Δt and hence a smaller transmission per square foot per hour.

These curves can be used with certainty as they are the results of experiment and they displace any formula for computations. They are better in this case as they show what may be obtained actually in practice.

HEAT THROUGH WALLS AND PARTITIONS

The heat transmitted through walls and partitions is computed by

$$Q = K(t_1 - t_2)F \quad (58)$$

where
$$K = \frac{1}{\frac{1}{a_1} + \frac{l'}{c'} + \frac{l''}{c''} + \dots + \frac{1}{a_2}} \quad (59)$$

Q = B.t.u. per hour.

t_1 = temperature on one side in degrees F.

t_2 = temperature on other side in degrees F.

F = area in square feet.

The value of a is found by experiment in the form

$$a = d + e + \frac{(42d + 31e)T}{1000} \quad (60)$$

d = constant depending on condition of air.
 = 0.82 air at rest in rooms or channels.
 = 1.03 air with slow motions, as over windows.
 = 1.23 air with quick motions, as outside of building.

e = constant depending on material.

T = temperature difference of film of air at wall.

Values of e

Cast iron	0.65
Cotton and fabrics	0.65
Charcoal	0.71
Glass	0.60
Metal, polished	0.05
Masonry	0.74
Paper	0.78
Rusted iron	0.69
Water	1.07
Wetted glass	1.09
Wood	0.74

For masonry walls, of thickness l ft.

$$T = 16.2 - 4.00l \quad (61)$$

For wood $T = 1.8^\circ \text{ F}$ (62)

For glass $T = \frac{1}{2}(t_1 - t_2)$ (63)

The values of c are given below:

Air (still)	0.03
Brass	61.00
Building paper	0.08
Cork	0.17
Cotton and felt	0.02
Glass	0.54
Masonry and plaster	0.46
Sandstone	0.87
Sawdust	0.03
Slate	0.19
Terra cotta	0.54
Tin	35.60
Wood	0.12

Experiments show that the values of c change with the temperature, but for the temperatures used in practice the variation is not great.

EFFICIENCY OF HEAT TRANSMISSIONS

The **efficiency of a heating surface** is the ratio of the heat abstracted by the surface from the gases to the amount of heat which the gas could give up to the surface. If T_{1h} is the temperature of the hot substance entering and T_{2h} is the temperature of the hot substance leaving the tube and T_c is the lowest temperature of the cool substance in contact with the opposite side of the surface, the expression for efficiency is

$$\eta = \frac{T_{1h} - T_{2h}}{T_{1h} - T_c} = 1 - \frac{T_{2h} - T_c}{T_{1h} - T_c} = 1 - \frac{\Delta t_2}{\Delta t_1} \quad (64)$$

This is true since the heat available in M lbs. of gas of specific heat c is

$$Q_1 = Mc(T_{1h} - T_c)$$

and the amount utilized is

$$Q_1 - Q_2 = Mc(T_{1h} - T_{2h})$$

In a given experiment the temperatures are known but with a given T_{1h} and T_c and with a given surface it is necessary to find T_{2h} in order to ascertain the efficiency.

There are two cases to consider:

First, if the cool substance changes in temperature along the surface.

Second, if the cool substance remains at a fixed temperature as in the case of a boiler.

In the first case it has been shown earlier in the chapter that

$$\begin{aligned} -M_h c_h dt_h &= K(t_{wh} - t_{wc})dF \\ -dF &= \frac{M_h c_h}{K} \frac{1}{(t_{wh} - t_{wc})} dt_h \\ &= \frac{M_h c_h}{K} \frac{1}{1 \pm \frac{M_h c_h}{M_c c_c} \frac{d\Delta t}{\Delta t}} = \text{const.} \frac{d\Delta t}{K\Delta t} \end{aligned}$$

If K is independent of temperature this becomes

$$FK \frac{1 \pm \frac{M_h c_h}{M_c c_c}}{M_h c_h} = \log_e \frac{\Delta t_1}{\Delta t_2}$$

$$\text{But } 1 \pm \frac{M_h c_h}{M_c c_c} = 1 - \frac{t_{1c} - t_{2c}}{t_{1h} - t_{2h}} = \frac{t_{1h} - t_{1c} - (t_{2h} - t_{2c})}{t_{1h} - t_{2h}}$$

$$\text{Hence } FK \frac{\Delta t_1 - \Delta t_2}{M_h c_h (t_{1h} - t_{2h})} = \frac{FK(\Delta t_1 - \Delta t_2)}{Q_1} = \log_e \frac{\Delta t_1}{\Delta t_2}$$

$$\frac{\Delta t_1}{\Delta t_2} = e^{-FK \frac{\Delta t_1 - \Delta t_2}{Q_1}}$$

$$\eta = 1 - e^{-FK \frac{\Delta t_1 - \Delta t_2}{Q_1}} \quad (66)$$

This shows that the efficiency of a surface increases with the increase of area, with the increase of the constant K or of the difference of Δt , but decreases as Q_1 increases. If, however, the area F is increased for a fixed length of tube by increasing the diameter, this apparently shows that the efficiency will increase with the diameter. It is known, however, that K varies with the velocity and hence this term would decrease with the square of the diameter so that the product FK would decrease with the increase of diameter and hence the efficiency would decrease. On the other hand, if d is decreased for a given length, the term FK is increased. In the above discussion Q_1 and $(\Delta t_1 - \Delta t_2)$ have been assumed to be constant but this would not be so for if d were decreased the velocity would be increased and with it Q_1 for a given length would be increased, but $(\Delta t_1 - \Delta t_2)$ would increase to a greater degree and the final result would be an increase of efficiency.

If K depends on $(\Delta t)^{-n}$, the integration gives

$$\begin{aligned} K'F \frac{\Delta t_1 - \Delta t_2}{Q_1} &= \frac{1}{n} [\Delta t_1^n - \Delta t_2^n] \\ \frac{nFK'}{Q_1} &= \frac{\Delta t_1^n - \Delta t_2^n}{\Delta t_1 - \Delta t_2} \\ \frac{\Delta t_1}{\Delta t_2} &= \frac{nFK'}{Q_1} \frac{\left(\frac{\Delta t_1}{\Delta t_2} - 1\right)}{\left(\Delta t_1^{n-1} - \frac{\Delta t_2}{\Delta t_1} \Delta t_2^{n-1}\right)} \\ \text{Eff.} = \eta &= 1 - \frac{Q_1}{nFK'} \frac{\Delta t_1^{n-1} - \frac{\Delta t_2}{\Delta t_1} \Delta t_2^{n-1}}{\frac{\Delta t_1}{\Delta t_2} - 1} \quad (67) \end{aligned}$$

In this as before the efficiency increases with FK' and decreases with Q_1 .

In the second case the temperature is constant on the cold side and the expression then becomes

$$+ M_h c_h dt_h = K(t_{xh} - t_c) dF$$

+ if dt is measured from cold to hot.

If K is independent of the temperature this becomes

$$\begin{aligned} \frac{K dF}{M_h c_h} &= \frac{dt_h}{t_{xh} - t_c} \\ \frac{K}{M_h c_h} F &= \log_e \frac{T_{1h} - T_c}{T_{2h} - T_c} \\ \frac{T_{1h} - T_c}{T_{2h} - T_c} &= \epsilon \frac{KF}{M_h c_h} \\ \eta &= 1 - \epsilon \frac{KF}{M_h c_h} \end{aligned}$$

In this as before the efficiency increases with the product KF and decreases with the quantity M . Thus if the diameter of a pipe is increased the velocity decreases for the same M or M increases for the same velocity. In each of these the exponent is decreased since M would vary with the square of d directly and K inversely. Hence the large diameter means a smaller efficiency. If M is increased for a given tube by increasing the velocity K will increase in the same ratio and the efficiency may not be changed. If the length is increased F is greater and the efficiency increases. Since this increase of efficiency is logarithmic, the increase beyond a certain value of F is very slow.

If K depends on the temperature the following results

$$\frac{K' dF}{M_h c_h} = (\Delta t)^{n-1} d\Delta t \quad (69)$$

This leads to an expression similar to the one used previously.

Kreisinger and Ray, in Bulletin 18 of the Bureau of Mines, show by results of tests on an experimental boiler that the efficiency decreased with the velocity to a certain point although the quantity of heat increased. In these experiments the value of M increased more rapidly than the coefficient of conduction. Of course if at the same time F were increased to its proper amount the efficiency would increase. In these experiments it was shown that the absorption of heat increased with the increase of the initial temperature although the rate of increase

of heat gradually diminished. The enlargement of the diameter of the tubes reduced the efficiency. Increasing the length of a tube increased the efficiency of the surface.

For a boiler Kreisinger and Ray have used the form for the value of K suggested by Perry.

$$K = K'mw$$

Hence

$$M_h c_h dt = K' m_h w_h \Delta t dF$$

but

$$m_h w_h = \frac{M_h}{F_o}$$

$$\therefore \frac{dt}{\Delta t} = \frac{K'}{F_o c_h} dF$$

$$\log_e \frac{\Delta t_1}{\Delta t_2} = \frac{K'}{F_o c_h} F$$

$$\Delta t_x = \Delta t_1 \epsilon^{-\frac{K'}{F_o c_h} F_x}$$

$$\eta = 1 - \epsilon^{-\frac{K' F_x}{F_o c_h}} \quad (70)$$

This expression for efficiency does not change with change in weights and therefore does not give curves similar to those found by experiment.

If the Reynolds form be used

$$M_h c_h dt_h = K' \left(A + B \frac{M}{F_o} \right) \Delta t dF$$

this leads to

$$\Delta t_x = \Delta t_1 \epsilon^{-\frac{(A+B \frac{M}{F_o}) F_x}{M_h c_h}}$$

and

$$\eta = 1 - \epsilon^{-\frac{(A+B \frac{M}{F_o}) F_x}{M_h c_h}} \quad (71)$$

This equation yields a curve similar to those found experimentally.

PROBLEMS

A number of problems will now be computed, applying the formulæ best suited for the work.

Problem 1.—A 4-in. boiler tube is used in a return tubular boiler with a grate of six times the flue area. Fifteen pounds of coal are burned per

square foot of grate per hour with 25 lbs. of air per pound of coal. The gases entering the tubes are 1350° F. and at exit they have been reduced to 600° F. What is the average value of the heating surface of tubes and how many pounds of water at the boiling point will be evaporated if the pressure is 130.3 lbs. gauge?

The formula to use in this case is that of Nicolson (40).

The gases are of practically the same density as air, hence $B = 53.35$.

$$\text{Mass of gas per tube} = \frac{\pi^4}{144} \times \frac{6 \times 15 \times (25 + 1)}{3600} = 0.0567 \text{ lbs. per second.}$$

$$\text{Mean temperature of gas} = \frac{1350 + 600}{2} = 975^\circ \text{ F.}$$

$$\text{Temperature of steam and water in boiler} = 355.8^\circ \text{ F.}$$

$$\phi = \frac{1}{2}(975 + 355.8) = 665.4$$

$$\text{Hydraulic radius} = \frac{1}{4} = 1.$$

$$\text{Area of tube} = \frac{\pi^4}{144} = 0.0872.$$

$$\begin{aligned} Q &= \left[\frac{665.4}{200} + \frac{\sqrt{665.4}}{40} (1 + 1) \frac{0.0567}{0.0872} \right] (975 - 355.8) \\ &= [3.327 + 0.839](619.2) = 2570 \text{ B.t.u.} \end{aligned}$$

$$\text{Now } r_{145} = 865.2 \text{ B.t.u.}$$

$$\text{Hence the pounds of steam per square foot} = \frac{2570}{865.2} = 2.97 \text{ lbs.}$$

This result is an average value per square foot for the whole boiler. The value of the shell directly over the fire increases the average to more than this value. If the temperature entering the flue had been higher this value would be greater.

For water tube boilers it is suggested that the area be considered the area between tubes and that the hydraulic radius be taken as the distance between tubes.

Problem 2.—Thus if the gases enter the tubes at a temperature of 1900° F. and leave at 600° F. and if the tubes are 3 in. apart and the value of $\frac{M}{F}$

is the same as before, the following results would hold for a water tube boiler.

$$\text{Mean temperature gases} = 1250^\circ \text{ F.}$$

$$\phi = 803$$

$$\text{Hydraulic radius} = 3 \text{ in. } \frac{M}{F} = 0.65$$

$$\begin{aligned} Q &= \left[\frac{803}{200} + \frac{\sqrt{803}}{40} (1 + \frac{1}{2}) 0.65 \right] (1250 - 355.8) \\ &= [4.015 + 0.613](894.2) = 4120 \text{ B.t.u.} \end{aligned}$$

$$\text{Weight of steam} = \frac{4120}{865.2} = 4.76 \text{ lbs.}$$

Problem 3.—Air at 350° F. is to be cooled to 75° F. in an intercooler made up of $\frac{3}{4}$ -in. tubes with the air passing through the tubes and cooled

by water entering at 60° F. and leaving at 90° F. Find mean Δt if (a) K is independent of temperature and (b) if $K = \frac{K'}{(\Delta t)^{1/3}}$.

In this problem it is evident that a counter-current flow must be employed since the water leaving the intercooler is higher than the air leaving.

$$\Delta t_1 = 350 - 90 = 260^\circ \text{ F.}$$

$$\Delta t_2 = 75 - 60 = 15^\circ \text{ F.}$$

$$\text{Now } \Delta t_1 - \Delta t_2 = 245 > \frac{1}{10} \left(\frac{\Delta t_1 + \Delta t_2}{2} \right) = \frac{1}{10} \left(\frac{260 + 15}{2} \right) = \frac{137.5}{10}$$

Hence the exact methods must be used.

$$(a) \text{ Mean } \Delta t = \frac{\Delta t_1 - \Delta t_2}{\log_e \frac{\Delta t_1}{\Delta t_2}} = \frac{260 - 15}{\log_e \frac{260}{15}} = \frac{245}{2.3 \times 1.237} = 86.2$$

$$(b) \text{ Mean } \Delta t = \left[\frac{1/3(\Delta t_1 - \Delta t_2)}{\Delta t_1^{1/3} - \Delta t_2^{1/3}} \right]^{3/2} = \left[\frac{81.7}{6.382 - 2.466} \right]^{3/2} = 95.5$$

Problem 4.—Find the heat per square foot for temperature conditions of problem 3 if the water has a velocity of 5 ft. per second over the tube and the air has a velocity of 20 ft. per second. The pressure of the air is 70.3 lbs. gauge.

m for air at 85 lbs. abs. and at $\frac{350 + 75}{2}$ or 212.5° F.

$$= \frac{85 \times 144}{53.35 \times 672.5} = 0.341 \text{ lbs.}$$

(a) Using (30) and (32):

$$L = \frac{0.341 \times 20}{62.5 \times 5} = 0.02185$$

$$K = \frac{6}{2 + 0.022} \times 0.341 \times 20 = 20.2$$

Now $Q = K (\text{mean } \Delta t) = 20.2 (86.2) = 1740 \text{ B.t.u.}$

(b) Using (41):

$$Q = 3600 \left\{ 0.0015 + \left[0.000506 - 0.00045 \times \frac{3}{16} + 0.00000165 - \left(\frac{212.5 + 75}{2} \right) \right] (20 \times 0.341) \right\} (212.5 - 75) = 21.6(137.5) = 2970 \text{ B.t.u.}$$

(c) Using (42'):

$$\lambda_{\text{wall}} = 0.01287(1 + 127 \times 10^{-5} \times 43) = 0.0135$$

$$\lambda_{\text{gas}} = 0.01287(1 + 127 \times 10^{-5} \times 180.5) = 0.01583$$

$$K = 15.90 \frac{0.0135}{(3/48)^{0.214}} \left[\frac{20 \times 0.24 \times 0.341}{0.01583} \right]^{0.786} = 15.0.$$

$$Q = 15.0 \times 86.2 = 1293 \text{ B.t.u.}$$

(d) Using (43) and (44):

$$K = \frac{126 \times 0.341 \times (18.25)^{0.4} (5)^{1/3}}{(95.5)^{1/3}} = 36.6$$

$$Q = 36.6 \times 95.5 = 3490 \text{ B.t.u.}$$

The results do not agree very well and result (d) is very high with (b) next, while result (c) is very low. The reason for the low value of (a) is due to the fact that the data from which equation (32) was deduced holds for smaller differences of temperature. Equation (32) will in general give results on the safe side as the temperature differences for which it holds are small.

Problem 5.—A sterilizer operates on a counter-current principle with the warm water entering at 212° F. and leaving at 75° F. and the cool water entering at 70° F. and leaving at 202° F. The liquid moves at a velocity of 2 ft. per second. Find the mean Δt : (a) if K is constant, (b) if $K = \frac{K'}{\Delta t^{1/2}}$ and (c) arithmetic mean Δt of Δt 's at the two ends.

$$\Delta t_1 = 212 - 202 = 10^\circ \text{ F.}$$

$$\Delta t_2 = 75 - 70 = 5^\circ \text{ F.}$$

$$(c) \frac{\Delta t_1 + \Delta t_2}{2} = 7\frac{1}{2}^\circ \text{ F.}$$

$$(a) \text{ Mean } \Delta t = \frac{\Delta t_1 - \Delta t_2}{\log_e \frac{\Delta t_1}{\Delta t_2}} = \frac{10 - 5}{2.3 \times 0.301} = 7.24$$

$$(b) \text{ Mean } \Delta t = \left[\frac{\frac{1}{2}(\Delta t_1 - \Delta t_2)}{\Delta t_1^{1/2} - \Delta t_2^{1/2}} \right]^2 = \left[\frac{2\frac{1}{2}}{3.162 - 2.236} \right]^2 = 7.30$$

Problem 6.—Find K and Q per square foot for problem 5.

Use (29) with $K'' = 6$ for water and at 150° F., $m_w = 61.2$:

$$K = \frac{1}{\frac{1}{6m_w w_w} + \frac{1}{6m_c w_c}} = 3m_w w_w = 3 \times 61.2 \times 2 = 367$$

$$Q = 367 \times 7.24 = 2654 \text{ B.t.u.}$$

$$\text{By formula (55)} \quad K = \frac{60}{2} = 171$$

$$1 + \frac{10}{3}\sqrt{2}$$

$$Q = 171 \times 7.24 = 1240 \text{ B.t.u.}$$

Problem 7.—If the walls are $\frac{1}{16}$ in. thick in the sterilizer what is the drop in temperature in the copper of the tube to transmit the heat of problem 6?

Using equation (3) and the tabular value of C for this:

$$1240 = \frac{239.0(1 + 0.00003 \times 150)}{\frac{1}{16 \times 12}} (t_1 - t_2)$$

$$t_1 - t_2 = \frac{1240}{16 \times 12 \times 241} = 0.027^\circ$$

Even in this case the fall of temperature occurs mainly in the films of water.

Problem 8.—The temperature of the condensing water is 70° F. at inlet and 80° F. at outlet. The temperature of the steam is 105° F. Find mean Δt and the heat removed per square foot of cooling surface of admiralty

metal if the surface is clean and the pressure in the steam space is 1.2 lbs. absolute, and the velocity of the water is 4 ft. per second.

$$\Delta t_1 = 105 - 70 = 35^\circ \text{ F.}$$

$$\Delta t_2 = 105 - 80 = 25^\circ \text{ F.}$$

$$\text{Mean } \Delta t = \left[\frac{\frac{1}{8}(35 - 25)}{35^{\frac{1}{8}} - 25^{\frac{1}{8}}} \right]^{\frac{8}{7}} = \left[\frac{1.25}{1.560 - 1.496} \right]^{\frac{8}{7}} = 29.9$$

$$\rho = \frac{p_s}{p_t} = \frac{1.098}{1.200} = 0.914$$

$$K = \frac{630 \times 1 \times 1 \times \overline{0.914^2} \times 0.98 \times \sqrt{4}}{(29.9)^{\frac{1}{8}}} = 673 \text{ B.t.u.}$$

$$Q = 673 \times 29.9 = 2010$$

Problem 9.—Steam at 215° F. is used to heat water at 60° F. to 180° F. with the steam inside of copper pipes $\frac{3}{4}$ in. in diameter and 80 in. long. The velocity for the water is 2 ft. per second.

Using Orrok's formula:

$$\Delta t_1 = 215 - 60 = 155^\circ \text{ F.}$$

$$\Delta t_2 = 215 - 180 = 35^\circ \text{ F.}$$

$$\text{Mean } \Delta t = \left[\frac{\frac{1}{8}(155 - 35)}{155^{\frac{1}{8}} - 35^{\frac{1}{8}}} \right]^{\frac{8}{7}} = \left[\frac{15}{1.878 - 1.56} \right]^{\frac{8}{7}} = 82$$

$$K = \frac{630 \times 1 \times 1 \times 1.00 \sqrt{2}}{(82)^{\frac{1}{8}}} = 513$$

$$Q = 513 \times 82 = 42,100 \text{ B.t.u. per square foot.}$$

Using equation (51) of Hagemann's,

$$K = 10 + \left\{ 110 + 0.6 \left(215 + \frac{180 + 60}{2} \right) \right\} \sqrt{2}$$

$$= 10 + 441 = 451$$

$$Q = 451 \times \frac{155 + 35}{2} = 42,800 \text{ B.t.u. per square foot.}$$

Problem 10.—Suppose the pipe in problem 9 was used to boil water at 180° , find K and Q .

Using equation (52) of Jelinek:

$$K = \frac{1270}{\frac{1}{2} \sqrt{\frac{3}{4}} \times 80} = 1965$$

$$Q = 1965 \times (215 - 180) = 68,800 \text{ B.t.u.}$$

Problem 11.—A brine cooler has brine with a velocity of 1 ft. on one side at 20° to 10° F. and ammonia on the other at 0° F. Find K and Q per square foot.

In this problem the method will be to use the same constants as those used for steam to water. Using Hagemann's equation (51):

$$K = 10 + \left\{ 110 + 0.6 \left(0 + \frac{20 + 10}{2} \right) \right\} \sqrt{1}$$

$$= 10 + 119 = 129$$

$$Q = 129 \times 15 = 1935 \text{ B.t.u. per hour per square foot.}$$

For 4 ft. velocity this would give for K

$$K = 10 + 238 = 248$$

Problem 12.—An ammonia condenser uses steel pipes with water from 60° to 80° F. and ammonia at 90° F. The water velocity is 4 ft. per second. Using equation (50):

$$K = 130 \times \sqrt{4} = 260$$

$$Q = 260 \times \frac{30 - 10}{2.3 \log_e 3} = 260 \times 18.3 = 4750 \text{ B.t.u.}$$

Problem 13.—Find the number of sections required and the average heat transmitted per square foot for vento heaters to operate with steam at 220° F. (5 lbs. gauge) and to heat air from 60° F. to 114° F. when delivered across heater at 1200 ft. per minute.

From Fig. 30: Two sections will heat zero air to 60° F. and five sections will heat zero air to 115° F. at 1200 ft. per minute; 5 - 2 = 3 sections are required.

From Fig. 31: The average transmission for two sections with zero air is 2050 B.t.u. while with five sections 1600 B.t.u. are transmitted. The amount for the last three of the five sections will be

$$\text{Average transmission} = \frac{5 \times 1600 - 2 \times 2050}{3} = 1300 \text{ B.t.u.}$$

To find the result of this problem by formulæ in place of using the experimental curves the following is given:

$$\text{Mean } \Delta t = 220 - \frac{60 + 115}{2} = 132.5$$

$$K = 2 + 1.75 \sqrt{\frac{1200}{60}} = 9.83$$

$$Q = 9.83 \times 132.5 = 1300 \text{ B.t.u.}$$

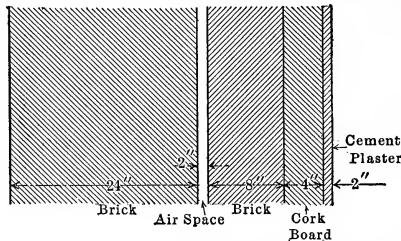

FIG. 34.—Section of wall for cold storage room.

Problem 14.—Find the value of K for the wall of a cold storage warehouse shown in Fig. 34.

$$T = 16.2 - 4.00 \times 3 = 4.2$$

$$a \text{ for outside} = 1.23 + 0.74 + \frac{42 \times 1.23 + 31 \times 0.74}{1000} \times 4.2 = 2.28$$

$$\left. \begin{array}{l} a \text{ for air space} \\ a \text{ for inside} \end{array} \right\} = 0.82 + 0.74 + \frac{42 \times 0.82 + 31 \times 0.74}{1000} \times 4.2 = 1.79$$

$$K = \frac{1}{\frac{1}{2.28} + \frac{2}{0.46} + \frac{1}{1.79} + \frac{1}{1.79} + \frac{0.67}{0.46} + \frac{0.33}{0.17} + \frac{0.17}{0.46} + \frac{1}{1.79}}$$

$$= \frac{1}{0.438 + 4.35 + 0.558 + 0.558 + 1.455 + 1.94 + 0.37 + 0.558}$$

$$= 0.0978$$

It will be noted that the amount of air space does not aid in the insulating value of the wall because the air can and will circulate. The value of this lies in the resistance at the two surfaces which amounts to almost as much as 8 in. of brickwork. The various terms of the denominator show the values of the various elements of the wall as heat insulators. Thus 4 in. of cork is as valuable as 11 in. of brickwork and may be used when space is of value. The wall above will transmit 2.35 B.t.u. per square foot per degree difference in 24 hours. For a temperature difference of 60° F. this amounts to 141 B.t.u. per day per square foot.

Topics

Topic 1.—By what methods is heat transmitted? Explain the peculiarities of each method. Give the Stefan-Boltzmann Law. For what is this used? How is it applied?

Topic 2.—What is the law of conduction as stated by a formula? Is the coefficient of conduction a constant? What are the dimensions of this coefficient? What fixes the amount of heat carried by convection? Why is convection of value in engineering problems? Is the heat in these problems carried by convection or conduction?

Topic 3.—How may it be shown that the films of substance at the surfaces of a partition or plate offer the greatest resistance to flow? What is the effect of velocity on film resistance? Explain why this is true. What was the work of Dalby? What was the work of Reynolds?

Topic 4.—Prove that

$$Q = K'mw(t - \theta)$$

Is this the equivalent of Reynold's expression

$$Q = (A + Bmw)(t - \theta)$$

Show that

$$\frac{M}{F} = mw$$

Topic 5.—What is meant by hydraulic radius? Determine the mean temperature difference along a surface if K is constant.

$$\left[\text{Mean } \Delta t = \frac{\Delta t_1 - \Delta t_2}{\log_e \frac{\Delta t_1}{\Delta t_2}} \right]$$

Topic 6.—What is meant by the constant K ? Prove that

$$\text{Mean } \Delta t = \left[\frac{n(\Delta t_1 - \Delta t_2)}{(\Delta t_1)^n - (\Delta t_2)^n} \right]^{\frac{1}{1-n}}$$

if $K = \frac{K'}{(\Delta t)^n}$.

Topic 7.—Prove that

$$K = \frac{1}{\frac{l_I}{c_I} + \frac{l_{II}}{c_{II}} + \frac{l_{III}}{c_{III}} + \dots}$$

To what does this relation reduce for ordinary transmission through thin partitions?

Is c a constant? What is the form to which Nicolson reduces this value of K above?

$$\begin{array}{l} \text{Topic 8.—Given:} \quad \frac{1}{K} = \frac{1}{3m_g w_g} + \frac{1}{6m_w w_w} \\ \text{reduce} \quad K = \frac{L}{2+L} 6m_w w_w = \frac{6m_g w_g}{2+L} \end{array}$$

Topic 9.—What are the formulæ of Nicolson, Jordan and Nusselt? Are these formulæ applicable to the same conditions? On what does the heat per square foot per degree per hour depend? Give details and reasons.

Topic 10.—For what conditions is the Rensselaer formula applicable? For what is Orrok's formula used? On what does the K of Orrok's formula depend? On what for the Rensselaer formula?

Topic 11.—Is Orrok's formula applicable to ammonia condensers, evaporators and feed-water heaters? Are special formulæ given for these forms of apparatus? Give the formulæ used for finding K for these. What is the value of K for direct steam radiators? For indirect steam radiators?

Topic 12.—Explain the method of finding the heat transmitted per square foot of surface per hour in Vento heaters and in pipe coils used as indirect heaters.

Topic 13.—Explain the method of finding the value of K for a wall or partition.

Topic 14.—Derive the expression for the efficiency of heat transmission

$$\eta = 1 - \epsilon^{-FK \frac{\Delta t_1 - \Delta t_2}{Q}}$$

when K is independent of the temperature. Give all steps and discuss the variation of the efficiency of a surface with velocity, diameter of pipe, length, temperature, and heat.

Topic 15.—Starting with Reynolds' value of K

$$K = K' \left(A + B \frac{M}{F} \right)$$

reduce the expression for the efficiency of a heating surface.

$$\eta = 1 - \epsilon^{-\frac{(A + B \frac{M}{F_o}) F}{M h c}}$$

PROBLEMS

Problem 1.—A piece of glass is held at 750° F. and a shield covers two-thirds of this. The surface of the glass is 2 sq. ft. The surface of the shield is 20 sq. ft. The shield is held at 125° F. by a water-jacket. How much heat is removed by the water-jacket?

Problem 2.—A 4-in. boiler tube has gas entering at one end at 1400° F. and leaving at 550° F. with steam at 120 lbs. gauge pressure. The coal is burned

on a grate of eight times the area through the tubes at a rate of 15 lbs. per hour with 30 lbs. of air per pound of coal. Find the value of K and the number of B.t.u. per square foot of surface. How many square feet of surface would be required per boiler horse-power? (One boiler horse-power equals the evaporation of $34\frac{1}{2}$ lbs. of water at 212° F. per hour into dry steam at 212° F.)

Problem 3.—A feed-water heater uses steam at 3 lbs. gauge pressure to heat 6000 lbs. of water per hour from 60° to 200° F. The water is passed through at a velocity of 2 ft. per second. Find mean Δt assuming K constant. Find K by two formulæ. Find the square feet of surface necessary. Of what material will the tube be made? Why?

Problem 4.—An economizer is used to heat 6000 lbs. of water per hour from 60° F. to 200° F. by using hot gas at 500° F. in 3-in. iron flues in which the temperature is reduced to 350° F. The velocity of the gas is 25 ft. per second. What is the value of mean Δt ? Find K by Nusselt's formula. Find the amount of surface required. Also use the simple formula suggested by Nicolson in which L is employed.

Problem 5.—In a condenser the water enters at 50° F. and leaves at 65° F. with a pressure in the condenser of 0.6 lbs. absolute and a temperature of 80° F. What is the value of mean Δt for this case? Find K for copper tubes if dirty. Find the square feet per kilowatt of turbo generator if steam consumption is 14 lbs. with x of exhaust steam equal to 0.95.

Problem 6.—Find the size of the condenser for an ammonia plant to remove 200,000 B.t.u. per hour with water flowing at 5 ft. per second in the double pipe, entering at 65° F. and leaving at 80° F., when the ammonia is at 100° F.

Problem 7.—A boiler using a 24-in. flue has gas entering at 1600° F. and leaving at 1000° F. The steam is at 300° F. The velocity of the gas is 100 ft. per second. Find the heat transmitted per hour per square foot of flue.

Problem 8.—An intercooler receives air at 250° F. and cools it to 80° F. The water enters at 50° F. and leaves at 70° F. Find mean Δt for parallel and counter-current flow using $K = \text{constant}$ and $K = \frac{K'}{\Delta t^2}$. Find the heat transmitted per square foot per hour.

Problem 9.—Find the surface required in an interchanger cooling 7000 lbs. of water per hour from 220° F. to 80° F. by water entering at 60° F. and leaving at 200° F. Use $K = \text{constant}$.

Problem 10.—Find the surface required to boil 500 lbs. of solution at 200° F. by steam at 250° F. if tubes 3 ft. long and 3 in. in diameter are used and the heat of vaporization of the liquid is 750 B.t.u.

Problem 11.—Assume air at 50° F. and move it with a velocity of 1200 ft. per minute over the Vento heaters or coils to heat it to 105° F. How many sections will it take for the Vento heaters and for the coils? How many square feet of each will be required to heat 200,000 cu. ft. of air per hour?

Problem 12.—Find the K for a wall composed of 16 in. of brickwork, a 2-in. air space and 12 in. of brickwork with 1 in. of cement plaster.

CHAPTER IV

AIR COMPRESSORS

Compressed air is used for many purposes for which it would be difficult to employ other media. For operating small tools, rock drills, and hoists and for the transmission of power over considerable distance it replaces steam with which the loss due to condensation is very excessive. The **efficiency of transmission** of power by compressed air is not equal to that of electrical transmission nor is it as flexible, yet in certain cases for some reasons it is of value. For cleaning materials with a sand blast

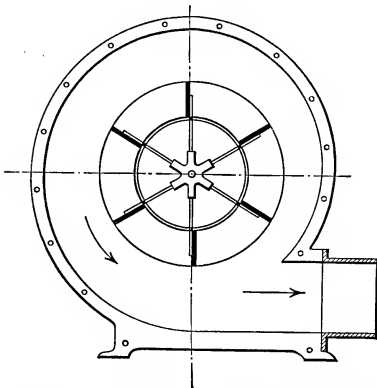

FIG. 35.—Section of radial blade fan blower.

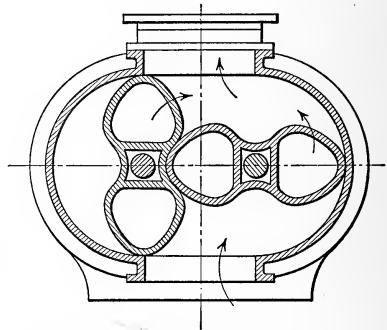

FIG. 36.—Rotary blower, section.

and for use with the cement gun compressed air is necessary. To force air into a furnace of a boiler or for a blast furnace a compressor of some form is required. Compressed air may be used in air-lift pumps and in direct air pumping. In supplying air to divers, in the making of liquid air and in the operation of street cars compressed air is required.

To compress this air several types of compressors are used. For low pressures up to 10 oz. per square inch above or below the atmosphere, **centrifugal or fan blowers**, Fig. 35, are used. In these, radial or curved blades are driven at a high speed causing a

flow of air. These are used for ventilation of buildings; for supply of air to boiler furnaces or cupolas; for forges; for suction in an induced draft system or for the conveying of light materials. In forge work Sangster allows 140 cu. ft. of free air per minute per forge at 2 oz. pressure. If an exhaust fan is used 600 cu. ft. of air per minute at $\frac{3}{4}$ oz. pressure are handled per forge. The air required in cupolas is 40,000 cu. ft. per ton of iron melted. For ventilation 2000 cu. ft. of air are allowed per person per hour.

For pressures of from 8 oz. to 7 lbs. per square inch, **rotary blowers** such as that shown in Fig. 36 are used. These are run at a sufficient speed to get the necessary discharge in cubic feet.

For pressures up to 35 lbs. **turbo compressors** of the form shown in Fig. 37 are used although piston compressors are used for this pressure at times. The air at this pressure is used in blast furnaces and converters and the compressors of the piston type for such are known as **blowing engines** or **blowing tubs**. These are only special forms of air compressor.

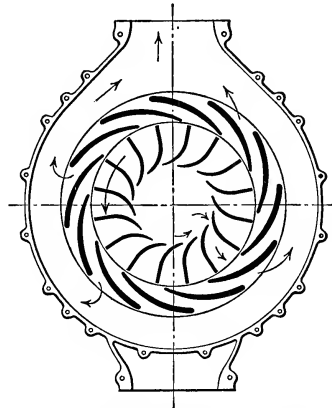

FIG. 37.—Section of turbo blower.

For higher pressures than 35 lbs. the **piston compressor** is in general employed, although the **hydraulic compressor** or the **Humphrey explosion compressor** could be used. For high pressures it will be shown that efficient work necessitates the compression in one cylinder to a pressure much below that desired and then a further compression of this air to a higher pressure. It may be that a third compression is used before the desired pressure is reached. Each one of these cylinders is known as a **stage**. The compressor mentioned above would be known as a **two-stage compressor**. In general **one stage** is used to 70 or 80 lbs. gauge pressure while from that to 500 lbs. **two stages** are used, and **three stages** from 500 to 1500 lbs. Above this **four stages** would be used. Fig. 38 shows a two-stage compressor. In this air is sucked into the center of the piston *A* by the vacuum produced behind the piston when the piston moves to the left, the air flowing through an opening left at the periphery *B*, as shown in Fig. 39. The air on the left of the piston is compressed and after it reaches the pressure

existing above the **mushroom valve** at *C* this opens and allows the air to exhaust into the **discharge pipe** *D* and from this into the **intercooler** *E* in which the air is cooled by water in the pipes *F*. The water is caused to circulate back and forth in this inter-

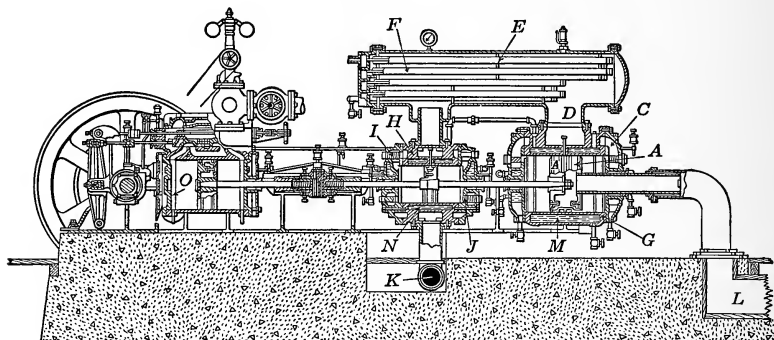

FIG. 38.—Section of two-stage Ingersoll-Rand compressor.

cooler. The air just compressed in cylinder *G* is forced through the intercooler into the cylinder *H* where it is compressed to a higher pressure. In this cylinder the **inlet valves** *I* are at the top of the cylinder while the **discharge valves** *J* are at the lower part of the cylinder head. Both sets of these are **mushroom valves**.

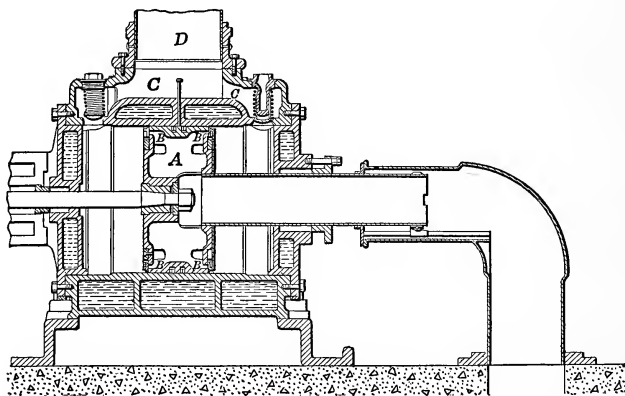

FIG. 39.—Enlarged section of L. P. air cylinder of Ingersoll-Rand compressor.

The air is finally sent to the **air storage tank** or **aftercooler** through the pipe *K*.

Fig. 38, which is the Ingersoll-Rand class AA-2 compressor, illustrates one form of two-stage air compressor in which the

driving steam cylinder *O* is in line with the two air cylinders and the fly wheels are driven by outside connecting rods. The figure illustrates the method of bringing cool air to the compressor from a point outside of the engine room through the conduit *L* and at *M* and *N* are the water jackets to remove some of the heat of compression.

Fig. 39 is introduced to show the valves of the low-pressure cylinder. In the periphery of each face of the piston are a series of slots distributed around the piston through which air can pass. Over this is fitted a ring which closes this opening and acts as a valve. This is known as the **hurricane inlet valve**. When the piston moves to the left at the beginning of a stroke the right-hand ring is moved from its openings and air can enter behind the right side, the compressed air on the left holding closed the valve on the left side. At the end of the stroke the inertia of the ring tends to close the right one as the piston reverses and the left one will open as soon as the pressure of the air in the left-hand clearance space expands to atmospheric pressure. The discharge valves are ordinary mushroom

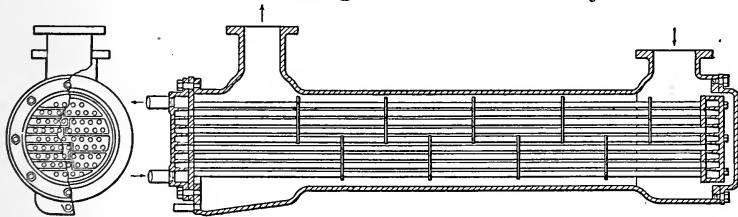
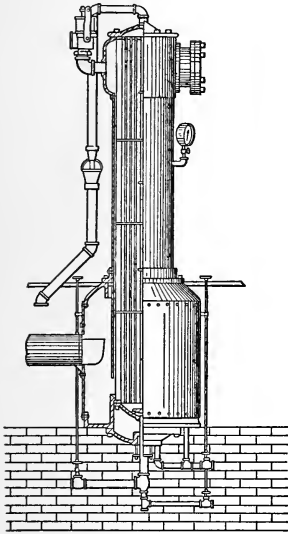

FIG. 40.—Vertical after cooler and intercooler of Igersoll-Rand Co.

valves with a light spring to close them and a tube on the back to act as a guide.

Fig. 40 shows the construction of an intercooler, through which the air must pass from one stage to another and give up its heat. By the arrangement of **baffle-plates** and **partitions** the air and water are made to take a circuitous path so as to be more efficient in the removal of heat. The moisture which separates

as the air is cooled is usually caught as shown in the figure so that it will not pass over into the next stage.

In many cases an **after cooler**, Fig. 40, is used after the last stage to remove more of the moisture from the air and to cool it before it passes into the transmission line. In this way the air is of smaller volume and there is less friction.

Fig. 41 illustrates the arrangement of the **Taylor hydraulic air compressor**. In this a system for the flow of water must exist. Suppose the **dam A** gives a **head** of H feet and this causes water to flow through the pipes B, C, D, E to the **tail race F**. The head and friction will cause a certain flow through the system

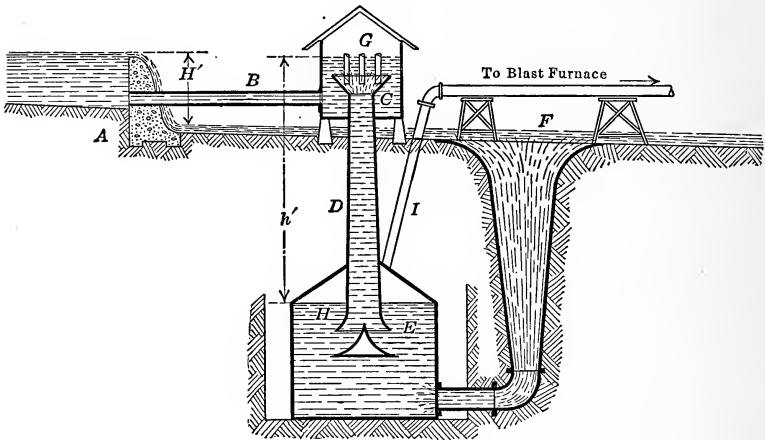

FIG. 41.—Taylor hydraulic air compressor.

and if the pipe is **necked** at C the velocity may become so high that a vacuum is formed at this point and air is drawn in through openings placed here. The air enters from G . This air mixes with the water and when the velocity is decreased in H the air separates out and rises to the surface of the water. This air is under pressure due to the head h on the chamber G . The air is taken out through the pipe I .

The Humphrey apparatus is described in *Engineering*, Vol. LXXXVIII, p. 737, and in "*Compressed Air Practice*" by Richards.

In all of these forms of apparatus the volume of air taken in might be the same while that discharged is determined by its pressure and temperature. To give some idea of the amount of

air used by tools or machines and the amount handled by the compressor it is customary to reduce the air to some one standard condition. The conditions taken are 14.7 lbs. absolute pressure and 60° F. temperature. This air is known as "free air." At times the temperature is assumed to be that of the atmosphere at the time of use, in which case the term free air refers to air at atmospheric pressure regardless of temperature.

With this introduction the thermodynamics of compressed air will be considered.

WORK OF COMPRESSION

The amount of work required to compress V_f cu. ft. per minute of free air is shown by the diagram of Fig. 42 which assumes no clearance. The line ab is the atmospheric line and on account of the friction of the inlet pipe and valves, the initial pressure p_1 is below atmospheric pressure. The air is sucked in on the suction line cl and is compressed from 1 to 2 on the line $pv^n = \text{const.}$ and is then driven out from 2 to d . The pressure at 1 is p_1 and the volume is V_1 . The atmospheric pressure is p_a and the free air V_f after throttling occupies the volume V_1 . The throttling action means constant heat content which for a perfect gas means isothermal action.

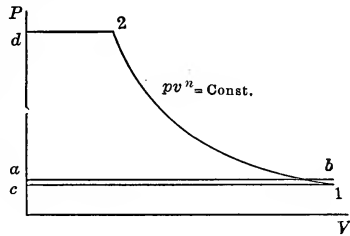

FIG. 42.—Indicator card from compressor with no clearance.

Hence
$$p_a V_f = p_1 V_1 \tag{1}$$

Some authors say that the air changes its temperature in entering the cylinder, but this cannot be appreciable as air is such a poor conductor of heat that it would take up little or no heat from the walls and the throttling of itself is isothermal.

Now the work of compression is

$$\frac{p_2 V_2 - p_1 V_1}{1 - n} - p_2 V_2 + p_1 V_1 = W \tag{2}$$

This quantity is negative since the work is done on the gas. A negative answer means that work is done on the gas.

Reducing:

$$\left(\frac{1}{n-1} + 1\right)(p_1 V_1 - p_2 V_2) = \frac{n}{n-1} p_1 V_1 \left[1 - \frac{p_2 V_2}{p_1 V_1}\right]$$

$$\begin{aligned} \text{Now } p_2 V_2^n &= p_1 V_1^n \\ \therefore \frac{p_2 V_2}{p_1 V_1} &= \left(\frac{V_1}{V_2}\right)^{n-1} = \left(\frac{p_2}{p_1}\right)^{\frac{n-1}{n}} \end{aligned}$$

$$\text{Hence work} = \frac{n}{n-1} p_1 V_1 \left[1 - \left(\frac{p_2}{p_1}\right)^{\frac{n-1}{n}} \right] \quad (3)$$

If desired $p_a V_f$ may be substituted for $p_1 V_1$ giving work to compress V_f cu. ft. of free air from p_1 to p_2 as

$$\text{work} = \frac{n}{n-1} p_a V_f \left[1 - \left(\frac{p_2}{p_1}\right)^{\frac{n-1}{n}} \right] \quad (4)$$

EFFECT OF CLEARANCE

Now if there is clearance the indicator card takes the form shown in Fig. 43. The air remaining in the cylinder, $d2'$, at the end of discharge expands from $2'$ to $1'$ on the return stroke, preventing air from entering until $1'$ is reached. The amount of air then taken in is $V''_1 - V'_1$, or $V''_1 - V'_1 = V_1$ of the previous discussion.

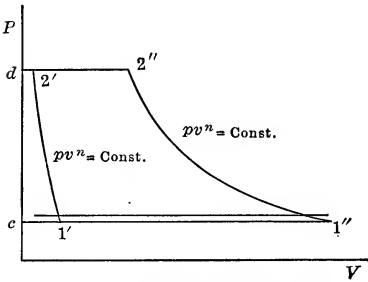

FIG. 43.—Effect of clearance.

The net work required to drive the compressor is area $1''2''2'1'$ or area $1''2''dc - 1'2'dc$. This, assuming the same form

of expansion and compression lines, gives

Net work with clearance =

$$\begin{aligned} &\frac{n}{n-1} p_1 V''_1 \left[1 - \left(\frac{p_2}{p_1}\right)^{\frac{n-1}{n}} \right] - \frac{n}{n-1} p_1 V'_1 \left[1 - \left(\frac{p_2}{p_1}\right)^{\frac{n-1}{n}} \right] \\ &= \frac{n}{n-1} p_1 [V''_1 - V'_1] \left[1 - \left(\frac{p_2}{p_1}\right)^{\frac{n-1}{n}} \right] \\ &= \frac{n}{n-1} p_1 V_1 \left[1 - \left(\frac{p_2}{p_1}\right)^{\frac{n-1}{n}} \right] \quad (5) \end{aligned}$$

This is the same expression as (3) for the compression of V_1 cu. ft. of air from pressure p_1 to p_2 , or in other words clearance has no effect on the work required to compress a definite volume of air. The effect of clearance is to decrease the amount of air taken in for a given displacement or to increase the displacement

for a given amount of air taken in. Thus in Fig. 42 the air taken in is V_1 and the displacement $D = V_1$, but in Fig. 43 the air taken in is V_1 but the displacement $D = V_1 + 1'c - 2'd$, a quantity greater than V_1 . In other words the displacement has been increased. This increase of displacement means a larger cylinder in stroke or area of piston and hence there will be more friction and consequently more work will be required to drive the compressor, but the work indicated on the air for the compression of a certain amount is the same with or without clearance.

The volume $2'd$ represents the volume of the **clearance space** and since this is usually expressed as a percentage of the displacement it may be represented as lD , where l is the **percentage clearance** and D is the displacement.

$$\begin{aligned} \text{Now} \qquad \qquad \qquad 1'c &= 2'd \left(\frac{p_2}{p_1}\right)^{\frac{1}{n}} \\ &= lD \left(\frac{p_2}{p_1}\right)^{\frac{1}{n}} \end{aligned}$$

$$\begin{aligned} \text{Hence} \qquad V_1 &= D + lD - lD \left(\frac{p_2}{p_1}\right)^{\frac{1}{n}} \\ &= D \left[1 + l - l \left(\frac{p_2}{p_1}\right)^{\frac{1}{n}}\right] \end{aligned} \qquad (6)$$

The term $1 + l - l \left(\frac{p_2}{p_1}\right)^{\frac{1}{n}}$ is called the **clearance factor**. It may be represented by K_l . This term is only used to find the displacement if V_1 is given or V_1 if D is given. The **clearance ratio** l is known.

EFFECT OF LEAKAGE

If there is leakage around the piston, piston rod and through the valves the volume V_1 required to deliver a given amount of free air V_f must be increased so as to care for this leakage. If the amount of free air delivered is expressed as a percentage of the free air taken in or as a ratio to the free air taken in, the percentage is called the **leakage factor** f . Actual $V_1 = \frac{\text{desired } V_1}{f}$.

Although the leakage is effective during the compression, giving less work as the compression is carried higher, it may be considered that this loss occurs at the upper pressure only and

consequently increases the work by causing $\frac{V_1}{f}$ or $\frac{V_f}{f}$ to be substituted for V_1 or V_f . Thus

$$\text{work} = \frac{n}{n-1} p_1 \frac{V_1}{f} \left[1 - \left(\frac{p_2}{p_1} \right)^{\frac{n-1}{n}} \right] = \frac{n}{n-1} p_a \frac{V_f}{f} \left[1 - \left(\frac{p_2}{p_1} \right)^{\frac{n-1}{n}} \right] \quad (7)$$

The effect of leakage is to increase the work.

VOLUMETRIC EFFICIENCY

The **volumetric efficiency** is defined as the ratio of the free air delivered to the displacement of the compressor. If the **actual free air** is used this is the **actual volumetric efficiency** while if the **indicated free air** is used, the **indicated volumetric efficiency** is obtained. Thus if ab is the atmospheric line from an actual compressor, indicated volumetric efficiency or apparent volumetric

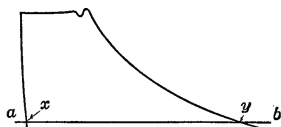

FIG. 44.—Card from compressor showing volumetric efficiency.

$$\text{efficiency} = \frac{xy}{D} = \frac{xy}{ab}$$

Now

$$xy = \frac{p_1 V_1}{p_a}$$

since the pressure is lowered by throttling action in which T is constant. The temperature of the cylinder walls may change the temperature of the air slightly but this is so slight that the air is considered to be at inlet temperature. Substituting for xy its value, the following is obtained

$$\text{Apparent vol. eff.} = \frac{p_1 V_1}{p_a D} = \frac{p_1}{p_a} \left[1 + l - l \left(\frac{p_2}{p_1} \right)^{\frac{1}{n}} \right] \quad (8)$$

$$\begin{aligned} \text{True vol. eff.} &= \frac{\text{actual } V_f}{D} = \frac{f \times \text{ind. free air}}{D} \\ &= f \times \text{ind. vol. eff.} = f \frac{p_1}{p_a} \left[1 + l - l \left(\frac{p_2}{p_1} \right)^{\frac{1}{n}} \right] \end{aligned} \quad (9)$$

$$\text{True vol. eff.} = \frac{p_1}{p_a} \times \text{leakage factor} \times \text{clearance factor.} \quad (10)$$

HORSE-POWER AND POWER OF MOTOR

If V_1 cu. ft. are required per minute the expression (7) gives the work per minute in foot-pounds. Consequently dividing the expression by 33,000 gives the horse-power shown by the air

card. This result must be divided by the **efficiency** of the air compressor, about 85 per cent. to 95 per cent. depending on size, before the horse-power to apply to the compressor is determined. To find the horse-power applied to the motor, be it a steam engine or an electric motor, the above result must again be divided by the efficiency of the motor. This may be about 90 per cent. Hence, horse-power applied to compressor for V_1 cu. ft. per minute

$$= \frac{n}{n-1} \frac{p_1 V_1}{\text{eff.} \times f \times 33000} \left[1 - \left(\frac{p_2}{p_1} \right)^{\frac{n-1}{n}} \right] \quad (11)$$

indicated horse-power of engine drive

$$= \frac{n}{n-1} \frac{1}{\text{eff. compressor} \times \text{eff. of engine}} \frac{p_1 V_1}{f \times 33000} \left[1 - \left(\frac{p_2}{p_1} \right)^{\frac{n-1}{n}} \right] \quad (12)$$

TEMPERATURE AT THE END OF COMPRESSION

If the temperature is T_1 at the beginning of compression the temperature at the end of compression is

$$T_2 = T_1 \left(\frac{p_2}{p_1} \right)^{\frac{n-1}{n}}$$

This is seen from the following:

$$\begin{aligned} p_2 V_2^n &= p_1 V_1^n \\ p_2 \left(\frac{BT_2}{p_2} \right)^n &= p_1 \left(\frac{BT_1}{p_1} \right)^n \\ p_2^{1-n} T_2^n &= p_1^{1-n} T_1^n \\ T_2 &= T_1 \left(\frac{p_2}{p_1} \right)^{\frac{n-1}{n}} \end{aligned} \quad (13)$$

COMPRESSION CURVE

The compression curve desired for air compression depends on the way in which the air is to be used after compression. Air is such a poor conductor of heat, and at 60 or 100 revolutions per minute the action of the compressor is so rapid, that expansion in an engine or compression in the compressor practically takes place along an adiabatic

$$pV^{1.4} = \text{const.}$$

If air is compressed along an adiabatic 1-2, Fig. 45, and is expanded along an adiabatic in the engine this adiabatic will be

2-1, if there is no leakage nor cooling between the compressor and engine. If, however, the air is stored in a tank for some time before using in the engine the air at a high temperature T_2 is cooled to the original temperature T_1 . This causes the volume to decrease so that the volume occupied by the air in the cylinder of the engine is V_2' where $2'$ lies on the isothermal $12'$. The **expansion line** in the engine is now $2'1'$ and the area $122'1'$ represents the loss of work due to the cooling in the tank. Although 1-2 is the best line for compression if the air is to be used before it can cool so that it will expand in the engine along 2-1 giving no loss, it is evident that 1-2' would be the better line if the air is to be stored before using, since the temperature along this line is constant. Hence it is often stated that isothermal compression is the **ideal and best method of compression**. This

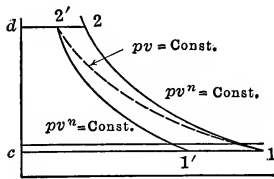

FIG. 45.—Saving due to cooling on compression.

is true, and true only, if storage of air is to be employed in the system, for other cases adiabatic compression may be the best method. If **isothermal compression** is used the work of compression becomes $12'dc$, resulting in a saving in work of the area $122'$. The loss when the expansion in the air engine takes place is then $12'1'$ instead of $122'1'$. The

expression for the work with isothermal compression without clearance is

$$\text{Work} = p_1 V_1 \log_e \frac{p_1}{p_2} - p_2 V'_2 + p_1 V_1$$

but

$$p_2 V'_2 = p_1 V_1$$

$$\therefore \text{Work} = p_1 V_1 \log_e \frac{p_1}{p_2} = - p_1 V_1 \log_e \frac{p_2}{p_1} \quad (14)$$

To approach this isothermal line in compression a **water jacket** is placed around the cylinder to remove heat, or water or oil is **sprayed** into the cylinder to reduce the heat. These methods are not very effective since n is changed only from $n = 1.4$ to $n = 1.35$. This saving is slight. The reason for this, as stated before, is the fact that the air is a poor conductor and also it is in contact with the cylinder walls a very short time.

HEAT REMOVED BY JACKET

The heat removed by the jacket is made up of two parts, that during the part of the stroke 1-2 and that during the part 2-d.

An expression may be written for the first part but no expression can be written for the part during the time that the piston moves from 2 to *d*. The temperature difference between the air and the jacket water is greatest during this time, but the cooling surface in contact with the air is decreasing and this effect would tend to decrease the cooling effect while the greater temperature difference would increase the effect. If the effect is assumed to be the same as that during the portion of the stroke 1-2, the total effect may be found by multiplying the effect

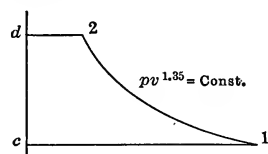

FIG. 46.—Card from compressor with jacket.

during 1-2 by $\frac{V_1}{V_1 - V_2}$ or $\frac{1}{1 - \left(\frac{p_1}{p_2}\right)^{\frac{1}{n}}}$

$$\begin{aligned} \text{Now heat removed on line 1-2} &= \frac{p_2 V_2 - p_1 V_1}{k - 1} + \frac{p_2 V_2 - p_1 V_1}{1 - n} \\ &= \left[\frac{1}{1 - k} + \frac{1}{n - 1} \right] p_1 V_1 \left[1 - \left(\frac{p_2}{p_1} \right)^{\frac{n-1}{n}} \right] \end{aligned}$$

From the above and by considering the leakage factor *f*, the following is obtained:

Heat removed by jacket

$$= \frac{1}{1 - \left(\frac{p_1}{p_2}\right)^{\frac{1}{n}}} \left[\frac{n - k}{(1 - k)(n - 1)} \right] \frac{p_1 V_1}{f} \left[1 - \left(\frac{p_2}{p_1} \right)^{\frac{n-1}{n}} \right] \quad (15)$$

SAVING DUE TO JACKET

The work done by the compressor when the exponent is changed from *k* of the adiabatic to *n* is

$$\text{Work} = \frac{n}{n - 1} \frac{p_1 V_1}{f} \left[1 - \left(\frac{p_2}{p_1} \right)^{\frac{n-1}{n}} \right]$$

The work for adiabatic compression is

$$\text{Work} = \frac{k}{k - 1} \frac{p_1 V_1}{f} \left[1 - \left(\frac{p_2}{p_1} \right)^{\frac{k-1}{k}} \right]$$

The saving due to the jacket is the difference of these or

$$\text{Saving} = \frac{p_1 V_1}{f} \left[\frac{k}{k - 1} \left\{ 1 - \left(\frac{p_2}{p_1} \right)^{\frac{k-1}{k}} \right\} - \frac{n}{n - 1} \left\{ 1 - \left(\frac{p_2}{p_1} \right)^{\frac{n-1}{n}} \right\} \right] \quad (16)$$

WATER REQUIRED FOR JACKET

If the heat removed by the jacket per minute is found, the water required is determined by assuming the possible range of temperature and then finding the water by

$$G = \frac{\text{heat per minute from jacket in B.t.u.}}{q'_o - q'_i} \quad (17)$$

G = weight of water per minute.

q'_o = heat of liquid at outlet.

q'_i = heat of liquid at inlet.

MULTISTAGING AND INTERMEDIATE PRESSURES

Although jacketing is used the slight change in the exponent does not give a great saving in work and moreover for high pressures T_2 becomes so great even with a jacket

$$\left[T_2 = T_1 \left(\frac{p_2}{p_1} \right)^{\frac{n-1}{n}} \right]$$

that the lubricating oil is apt to ignite and cause an explosion. To prevent this and to save work the air is compressed to a

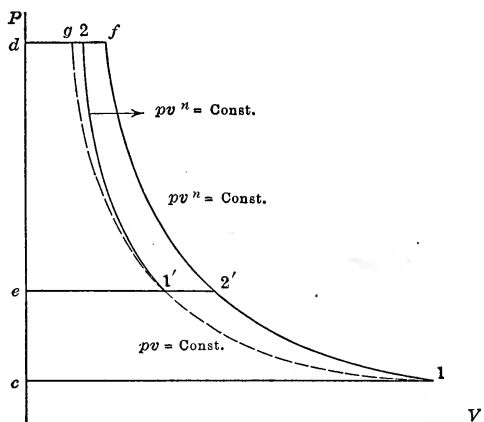

FIG. 47.—Two-stage compression.

pressure less than that finally desired and discharged from the cylinder into a chamber containing a number of tubes carrying cold water. This chamber is called an **intercooler** and the tubes are made of such an area and arranged in such a manner that the air is brought to its original temperature at 1 before it is

sent to a second cylinder of proper volume in which it is compressed to its final pressure. This method of compressing in two cylinders of different sizes is known as **two-stage compression**. The action is shown in Fig. 47. V_1 cu. ft. of air are drawn into the low-pressure cylinder and compressed to a pressure p'_2 . The air at a temperature $T_1 \left(\frac{p'_2}{p_1}\right)^{\frac{n-1}{n}}$ is then discharged from this cylinder and through the intercooler until its temperature is reduced to T_1 . The air is then drawn into the second cylinder which must be of such a volume as to take the air which occupies the volume V'_1 found on an isothermal through 1 at a pressure p'_2 . The air is then compressed to a pressure p_2 . The work in the two cylinders is given by

$$\text{Work in low-pressure cylinder} = \frac{n}{n-1} p_1 V_1 \left[1 - \left(\frac{p'_2}{p_1}\right)^{\frac{n-1}{n}} \right]$$

$$\text{Work in high-pressure cylinder} = \frac{n}{n-1} p'_2 V'_1 \left[1 - \left(\frac{p_2}{p'_2}\right)^{\frac{n-1}{n}} \right]$$

Now $p_1 V_1 = p'_2 V'_1$
Hence

$$\text{Total work} = \frac{n}{n-1} p_1 V_1 \left[2 - \left(\frac{p'_2}{p_1}\right)^{\frac{n-1}{n}} - \left(\frac{p_2}{p'_2}\right)^{\frac{n-1}{n}} \right] \quad (18)$$

The only variable in this expression is p'_2 . Hence to find the condition for minimum work, the first derivative with respect to p'_2 must be equated to zero.

$$\frac{d}{dp'_2} (\text{total work}) = \frac{n}{n-1} p_1 V_1 \left[-\frac{n-1}{n} \left(\frac{p'_2}{p_1}\right)^{\frac{n-1}{n}-1} \frac{1}{p_1} + \frac{n-1}{n} \left(\frac{p_2}{p'_2}\right)^{\frac{n-1}{n}-1} \frac{p_2}{p'^2_2} \right] = 0$$

$$\therefore \left(\frac{p'_2}{p_1}\right)^{-\frac{1}{n}} \frac{1}{p_1} = \left(\frac{p_2}{p'_2}\right)^{-\frac{1}{n}} \frac{p_2}{p'^2_2}$$

$$\left(\frac{p'^2_2}{p_1 p_2}\right)^{\frac{n-1}{n}} = 1$$

or $\frac{p'^2_2}{p_1 p_2} = 1$

$$p'_2 = \sqrt{p_1 p_2} \quad (19)$$

That is, the work is a minimum if p'_2 is a mean proportional between p_1 and p_2 .

Substituting this value of p'_2 in (13) the following results:

$$\begin{aligned} \text{Total work} &= \frac{n}{n-1} p_1 V_1 \left[2 - \left(\frac{p_2^{1/2} p_1^{1/2}}{p_1} \right)^{\frac{n-1}{n}} - \left(\frac{p_2}{p_2^{1/2} p_1^{1/2}} \right)^{\frac{n-1}{n}} \right] \\ &= \frac{2n}{n-1} p_1 V_1 \left[1 - \left(\frac{p_2}{p_1} \right)^{\frac{n-1}{2n}} \right] \end{aligned} \quad (20)$$

If there are three stages, proceeding in the same manner, the equation becomes

$$\text{Total work} = \frac{n}{n-1} p_1 V_1 \left[3 - \left(\frac{p'_2}{p_1} \right)^{\frac{n-1}{n}} - \left(\frac{p''_2}{p'_2} \right)^{\frac{n-1}{n}} - \left(\frac{p_2}{p''_2} \right)^{\frac{n-1}{n}} \right]$$

in which there are two variables, p'_2 and p''_2 . The conditions for a maximum or minimum are $\frac{\delta}{\delta p'_2} (\text{total work})_{p''_2} = 0$

and $\frac{\delta}{\delta p''_2} (\text{total work})_{p'_2} = 0$. These give $p'_2 = \sqrt{p_1 p''_2}$ and $p''_2 = \sqrt{p_2' p_2}$;

$$\begin{aligned} p'_2 &= \sqrt{p_1 \sqrt{p'_2 p_2}} \\ p'_2{}^2 &= p_1 \sqrt{p'_2 p_2} \\ p'_2{}^4 &= p_1^2 p'_2 p_2 \\ p'_2{}^3 &= p_1^2 p_2 \\ p'_2 &= \sqrt[3]{p_1^2 p_2} \end{aligned} \quad (21)$$

$$p''_2 = \sqrt{p_2 \sqrt[3]{p_1^2 p_2}} = \sqrt{\sqrt[3]{p_1^2 p_2^4}} = \sqrt[3]{p_1 p_2^2} \quad (22)$$

For m stages there will be $m - 1$ intermediate variable pressures in the expression for total work and there will be $m - 1$ partial derivatives to equate to zero giving, in the same manner as above,

$$p'_2 = \sqrt[m]{p_1^{m-1} p_2} \quad \text{or} \quad \frac{p'_2}{p_1} = \left(\frac{p_2}{p_1} \right)^{\frac{1}{m}} \quad (23)$$

$$p''_2 = \sqrt[m]{p_1^{m-2} p_2^2} \quad \text{or} \quad \frac{p''_2}{p'_2} = \left(\frac{p_2}{p_1} \right)^{\frac{1}{m}} \quad (24)$$

$$\dots \dots \dots$$

$$p_2''' \dots' = \sqrt[m]{p_1 p_2^{m-1}}$$

It is to be noted that the ratio of pressures on each stage is the same and each ratio of pressures on the various stages is equal to $\left(\frac{p_2}{p_1} \right)^{\frac{1}{m}}$. If these are substituted in the expression for total work the equation becomes

Total work for m -stage compression =

$$\frac{mn}{n-1} p_1 V_1 \left[1 - \left(\frac{p_2}{p_1} \right)^{\frac{m-1}{mn}} \right] \quad (25)$$

This is the general expression for the **work of an m stage compressor** on the compression line $pv^n = \text{const.}$, for any value of n except 1.

INTERMEDIATE TEMPERATURES

Since the ratios of pressures on each stage are equal to $\left(\frac{p_2}{p_1}\right)^{\frac{1}{m}}$ it follows that the temperatures at the end of compression, T_2 , are all the same and equal to

$$T_2 = T_1 \left(\frac{p_2}{p_1}\right)^{\frac{n-1}{mn}} \quad (26)$$

For a single-stage compression between p_1 and p_2

$$T_2 = T_1 \left(\frac{p_2}{p_1}\right)^{\frac{n-1}{n}}$$

HEAT REMOVED BY INTERCOOLER

In the intercooler the temperature is reduced at constant pressure from T_2 to T_1 and the heat is given by

$$\begin{aligned} \text{Heat from intercooler in foot-pounds} &= JM c_p (T_2 - T_1) \\ &= J \frac{p_1 V_1}{B T_1} c_p (T_2 - T_1) \\ &= p_1 V_1 \frac{c_p}{AB} \left(\frac{T_2}{T_1} - 1\right) \\ &= -\frac{k}{k-1} p_1 V_1 \left[1 - \left(\frac{p_2}{p_1}\right)^{\frac{n-1}{mn}}\right] \end{aligned} \quad (27)$$

If leakage is considered this becomes

$$\text{Heat} = -\frac{k}{k-1} \frac{p_1 V_1}{f} \left[1 - \left(\frac{p_2}{p_1}\right)^{\frac{n-1}{mn}}\right] \quad (28)$$

AMOUNT OF WATER FOR INTERCOOLER

In the above section the heat removed by the intercooler has been determined. The amount of water per minute required for the removal of this heat is found by assuming the temperature allowable at inlet and the temperature at outlet desirable and then computing by the formula,

$$G = \frac{\text{heat per minute from intercooler in B.t.u.}}{q'_o - q'_i} \quad (29)$$

G = weight of water per minute.

q'_o = heat of liquid at outlet.

q'_i = heat of liquid at inlet.

The area of the surface of intercooler is found by methods of Chapter III.

WATER REMOVED IN INTERCOOLER

If air at pressure p_a has a relative humidity ρ_a and the weight of 1 cu. ft. of moisture to saturate the air at the temperature T_1 is m_a , the total amount of moisture entering per minute is

$$M_w = \rho_a m_a V_f$$

When this is sent to the intercooler and cooled to temperature T_1 , after it is compressed to pressure p'_2 and volume V'_2 or $\frac{p_a}{p'_2} V_f$, the amount of moisture held in the air, if saturated, will be

$$M'_w = m_2 \frac{p_a}{p'_2} V_f.$$

This is less than M_w in most cases, so that the amount of moisture precipitated is

$$M_w - M'_w$$

If M'_w is greater than M_w the ratio $\frac{M_w}{M'_w}$ will give the relative humidity of the air leaving the intercooler. This same method can be used to compute the moisture removed by the after cooler.

EFFECT OF LEAKAGE IN MULTISTAGE COMPRESSIONS

The leakage in a multistage compressor is a variable quantity, the leakage making the amount of air handled by the various stages different. Thus if 3 per cent. is the leakage in a single stage the leakage in a three-stage compressor might be

$$1 - 0.97 \times 0.97 \times 0.97 = 0.088 = 0.09 \text{ approximately.}$$

That is, the amount of air to be handled by the lowest stage would be $\frac{V_1}{0.91}$, that by the second stage $\frac{V_1}{0.94}$ and that by the third would be $\frac{V_1}{0.97}$. Of course these differing amounts of air would change the theoretical discussion above but to a slight degree. Because of the similarity of relations for various stages the same pressure ratios will be used although the works on the various stages will not be the same. Hence in solving various problems the ex-

pression for total work will be used as derived before substituting $\frac{V_1}{f}$ for V_1 , and using as f the mean value of the various f 's for the m stages. In computing the displacement of the various stages the correct value of f for each stage will be used.

DISPLACEMENT OF CYLINDERS

The displacement of each cylinder can be computed after the leakage factor and clearance factor are known for the cylinder.

The leakage factor has been discussed in the previous section, and if 3 per cent. per cylinder is assumed the various leakage factors up to four stages may be taken as 88 per cent., 91 per cent., 94 per cent. and 97 per cent. The clearance factor is given by

$$K_l = 1 + l - l \left(\frac{p'_2}{p_1} \right)^{\frac{1}{n}}$$

or

$$= 1 + l - l \left(\frac{p_2}{p_1} \right)^{\frac{1}{mn}} \quad (30)$$

If the clearance is the same on each stage the clearance factor will be the same for each stage. If, as is often the case, the value of l is small for the low-pressure cylinder and gradually increases, the value of K_l will gradually become larger for the high-pressure cylinders. Equations (6) and (30) show that as $\frac{p_2}{p_1}$ or $\frac{p'_2}{p_1}$ becomes greater K_l becomes less and so the effect of pressure on this factor is quite noticeable. With very high pressures on any stage the volume of expanded air at the end of the expansion part of the stroke is so great that only a small quantity of air will be drawn in. This is **another reason for multistaging**.

Having K_l and f for any stage the displacement is found by

$$D = \frac{V_1^{x-1}}{f_x K_{lx}} = \frac{p_a V_f}{p_2^{x-1} f_x K_{lx}} \quad (31)$$

In other words, the free air to be handled multiplied by the ratio of the pressure of the atmosphere to the initial pressure on the stage considered gives the volume of the free air when at the pressure of this stage and this divided by the volumetric efficiency for this stage, $f_x K_{lx}$, gives the displacement per minute if V_f is the free air per minute.

If now the number of revolutions per minute is known and if the piston speed per minute allowable is assumed the length of stroke is known and then the area can be found after it is decided whether or not the compressor is double acting.

$$\text{Piston speed} = 2LN = 200 \text{ to } 700 \text{ ft. per minute.} \quad (32)$$

$$D = (F_h + F_c)LN. \quad (33)$$

F_h = area of head end of air piston in square feet.

F_c = area of crank end of air piston in square feet.

L = length of stroke in feet.

N = number of revolutions per minute.

SIZE OF INLET AND OUTLET PIPES AND VALVES

The valve and pipe areas are such that the velocity of air is from 3000 to 6000 ft. per minute. Although these are high the loss in pressure is not excessive. The suction valve is open during a longer time than the discharge valve and for that reason it seems to be necessary to use larger areas on the discharge valves. On the other hand, the effect of the drop is more noticeable at the lower suction pressure and therefore the suction valve must have a large area. The valves are of about the same area. This area of each set may amount to 8 per cent. of the piston area for piston speeds of 300 ft. per minute while for speeds of 700 ft. per minute 12 per cent. might be used.

The pipes connecting cylinders or carrying air to or from the compressor should be designed from the allowable velocity if short, while for long pipes the drop in pressure, to be considered later, should determine the size.

PERCENTAGE SAVING DUE TO MULTISTAGING OVER A SINGLE STAGE

$$\text{Work on single stage} = \frac{n}{n-1} \frac{p_1 V_1}{f} \left[1 - \left(\frac{p_2}{p_1} \right)^{\frac{n-1}{n}} \right]$$

$$\text{Work on multistage} = \frac{mn}{n-1} \frac{p_1 V_1}{f_m} \left[1 - \left(\frac{p_2}{p_1} \right)^{\frac{n-1}{mn}} \right]$$

$$\therefore \text{ per cent. saving} = 100 - 100 \frac{mf}{f_m} \frac{\left[1 - \left(\frac{p_2}{p_1} \right)^{\frac{n-1}{mn}} \right]}{\left[1 - \left(\frac{p_2}{p_1} \right)^{\frac{n-1}{n}} \right]} \quad (34)$$

This saving is equal to the area $1_122'2_1$, Fig. 48, and of course it is the difference between the work of single-stage compression and two-stage compression. The saving is equal to

$$\frac{n}{n-1} \frac{p_1 V_1}{f} \left[1 - \frac{mf}{f_m} - \left(\frac{p_2}{p_1} \right)^{\frac{n-1}{n}} - \frac{mf}{f_m} \left(\frac{p_2}{p_1} \right)^{\frac{n-1}{mn}} \right] \quad (35)$$

UNAVOIDABLE LOSS OF COMPRESSION ON TWO STAGES

The area $12_11_11'$, Fig. 48, represents an area which cannot be regained by a single-stage engine and may therefore be called the unavoidable loss. It is equal to $12_1ed - 1'1_1ed$.

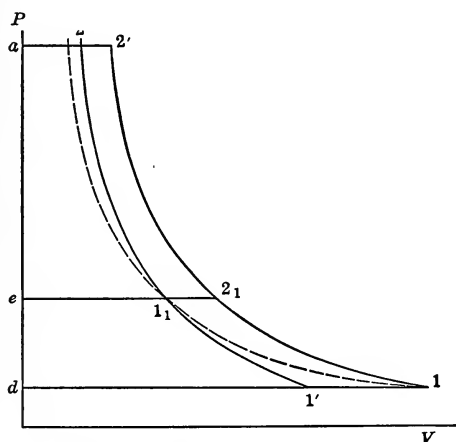

FIG. 48.—Saving due to multistaging.

$$\begin{aligned} \text{Loss} &= \frac{n}{n-1} p_1 V_1 \left[1 - \left(\frac{p_2}{p_1} \right)^{\frac{n-1}{2n}} \right] - \frac{n}{n-1} p_1 V'_1 \left[1 - \left(\frac{p_2}{p_1} \right)^{\frac{n-1}{2n}} \right] \\ &= \frac{n}{n-1} p_1 V_1 \left[1 - \frac{V'_1}{V_1} \right] \left[1 - \left(\frac{p_2}{p_1} \right)^{\frac{n-1}{2n}} \right] \\ &= \frac{n}{n-1} p_1 V_1 \left[1 - \frac{T'_1}{T_1} \right] \left[1 - \left(\frac{p_2}{p_1} \right)^{\frac{n-1}{2n}} \right] \\ &= \frac{n}{n-1} p_1 V_1 \left[1 - \left(\frac{p_1}{p_2} \right)^{\frac{n-1}{2n}} \right] \left[1 - \left(\frac{p_2}{p_1} \right)^{\frac{n-1}{2n}} \right] \quad (36) \end{aligned}$$

This is divided by f to give the total unavoidable loss with leakage. For three-stage compression the loss is really the work

on two stages minus the work returned from one stage between pressures p''_2 and p_1 .

$$\text{Loss} = \frac{2n}{n-1} p_1 V_1 \left[1 - \left(\frac{p_2}{p_1} \right)^{\frac{n-1}{3n}} \right] - \frac{n}{n-1} p_1 V'_1 \left[1 - \left(\frac{p_2}{p_1} \right)^{\frac{2(n-1)}{3n}} \right]$$

This is shown in Fig. 49.

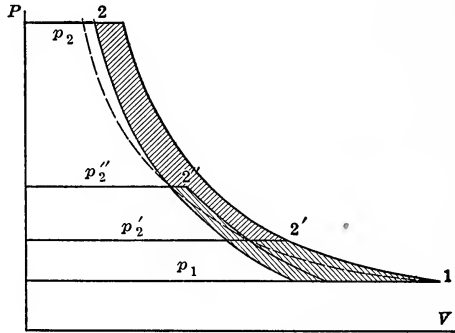

FIG. 49.—Losses and gains for three-stage compression.

WORK ON AIR ENGINE

Air engines are usually of one stage and as the air expands its temperature falls so that at the end of expansion the moisture in the air freezes and in many cases clogs up the exhaust. To prevent this heat may be applied to the exhaust pipe, multistaging may be used as shown in Fig. 51 or the air may be initially heated as shown in Fig. 50 by the dotted lines. This latter method produces such an increase in the work done that it will be carefully investigated later.

The pressures between which the air engine operates are p'_2 and p'_1 . These are different from p_2 and p_1 because there is a drop in pressure due to friction in the pipe line carrying air to the engine and in the valves entering the engine, thus changing p_2 to p'_2 . At exhaust the back pressure must be above the atmospheric pressure.

If there is **complete expansion** in the engine and if the exhaust valve is so timed that the **compression is complete**, there is no effect of clearance on the work. Complete expansion or compression means the carrying out of these actions until the final pressure is reached as shown in Fig. 52. The effect of clearance on the displacement is the same as that in the compressor and the

same formula is used. In all theoretical discussions complete expansion is assumed and, for the present, the case of work or quantity of air for an engine with incomplete expansion and compression will not be discussed.

The expression for work of the engine without clearance becomes, from Fig. 50,

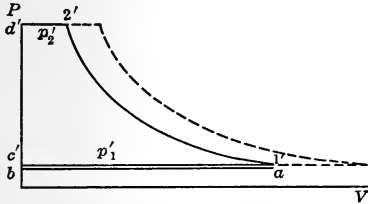

FIG. 50.—Single-stage engine card with expansion line after preheating.

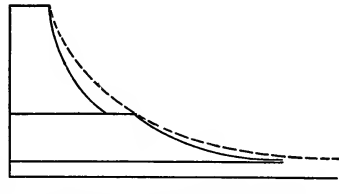

FIG. 51.—Two-stage engine card.

$$\begin{aligned} \text{Work of single-stage engine} &= p'_2 V'_2 + \frac{p'_1 V'_1 - p'_2 V'_2}{1 - k} - p'_1 V'_1 \\ &= \frac{k}{k - 1} p'_2 V'_2 \left[1 - \left(\frac{p'_1}{p'_2} \right)^{\frac{k-1}{k}} \right] \end{aligned} \quad (37)$$

In this case $p'_2 V'_2$ have been factored out because it is these two terms which are known in the case of the engine since the air is here at the original temperature T_1 ; while at the lower pressure the temperature is low and would have to be computed by

$$T'_1 = T_1 \left(\frac{p'_1}{p'_2} \right)^{\frac{k-1}{k}}$$

before $p'_1 V'_1$ could be found.

It is to be observed that $\left(\frac{p'_1}{p'_2} \right)^{\frac{k-1}{k}}$ is less than unity so that the expression for work is positive, and moreover $p'_2 V'_2 = p_1 V_1$ or $p_a V_f$ so that either of these may be substituted, giving

$$\text{Work on single-stage engine} = \frac{k}{k - 1} p_a V_f \left[1 - \left(\frac{p'_1}{p'_2} \right)^{\frac{k-1}{k}} \right] \quad (38)$$

For a multistage engine the work becomes

$$\text{Work} = \frac{mk}{k - 1} p_a V_f \left[1 - \left(\frac{p'_1}{p'_2} \right)^{\frac{k-1}{mk}} \right] \quad (39)$$

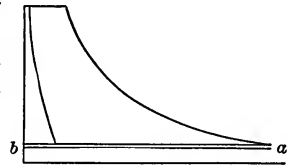

FIG. 52.—Card with complete expansion and compression in engine.

If leakage is considered this reduces the work, giving

$$\begin{aligned} \text{Work} &= \frac{mk}{k-1} p_a f V_f \left[1 - \left(\frac{p'_1}{p'_2} \right)^{\frac{k-1}{mk}} \right] \\ &= \frac{mk}{k-1} f M B T_a \left[1 - \left(\frac{p'_1}{p'_2} \right)^{\frac{k-1}{mk}} \right] \quad (40) \end{aligned}$$

The intermediate pressures are found as before

LOSS DUE TO COOLING AFTER COMPRESSION

The air is compressed to a temperature T_2 , for single or multiple staging, and on storing in the tank or pipe line its temperature is reduced to T_1 . The work which could have been done in one stage at the temperature T_2 would be given by

$$\text{Work} = \frac{k}{k-1} f M B T_2 \left[1 - \left(\frac{p'_1}{p'_2} \right)^{\frac{k-1}{k}} \right]$$

while after cooling to T_1 the work to be obtained is

$$\text{Work} = \frac{k}{k-1} f M B T_1 \left[1 - \left(\frac{p'_1}{p'_2} \right)^{\frac{k-1}{k}} \right]$$

Hence the loss is

Loss of work due to cooling

$$\begin{aligned} &= \frac{k}{k-1} f M B [T_2 - T_1] \left[1 - \left(\frac{p'_1}{p'_2} \right)^{\frac{k-1}{k}} \right] \\ &= \frac{k}{k-1} f p_a V_f \left[\frac{T_2}{T_1} - 1 \right] \left[1 - \left(\frac{p'_1}{p'_2} \right)^{\frac{k-1}{k}} \right] \\ &= \frac{k}{k-1} f p_a V_f \left[\left(\frac{p_2}{p_1} \right)^{\frac{n-1}{mn}} - 1 \right] \left[1 - \left(\frac{p'_1}{p'_2} \right)^{\frac{k-1}{k}} \right] \quad (41) \end{aligned}$$

In this the first bracket is due to the compressor, while the second refers to the engine.

UNAVOIDABLE LOSS DUE TO EXPANSION LINE

Another unavoidable loss is due to the fact that the expansion line in the engine is of the form $pV^k = \text{const.}$ while that used on the compressor has been of the form $pV^n = \text{const.}$ This means that with a single expansion engine the area shown in Fig. 53 by abc is unavoidably lost. This computation is made before cooling the air to the temperature T_1 and while it is at the point p_2V_2 . This loss is given by

$$\begin{aligned} \text{Loss} &= p_2 V_2 \left[\frac{n}{n-1} \left\{ 1 - \left(\frac{p_1}{p_2} \right)^{\frac{n-1}{n}} \right\} - \frac{k}{k-1} \left\{ 1 - \left(\frac{p_1}{p_2} \right)^{\frac{k-1}{k}} \right\} \right] \\ &= p_1 V_1 \left(\frac{p_2}{p_1} \right)^{\frac{n-1}{mn}} \left[\frac{n}{n-1} \left\{ 1 - \left(\frac{p_1}{p_2} \right)^{\frac{n-1}{n}} \right\} - \frac{k}{k-1} \left\{ 1 - \left(\frac{p_1}{p_2} \right)^{\frac{k-1}{k}} \right\} \right] \end{aligned} \tag{42}$$

Since

$$p_2 V_2 = \frac{T_2}{T_1} p_1 V_1 = \left(\frac{p_2}{p_1} \right)^{\frac{n-1}{mn}} p_1 V_1$$

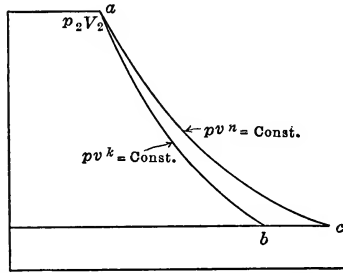

FIG. 53.—Unavoidable loss from difference in values of n in compressor and engine.

LOSS OF PRESSURE IN PIPE LINE

As the air flows through a pipe the pressure is decreased due to friction. There is only a slight change in velocity and hence this action is that of throttling in which the heat content and consequently the temperature of the perfect gas, air, remains constant. Now it is found that the drop in head when a fluid flows along a pipe line varies with the length of the pipe, with the square of the velocity and inversely with the diameter. This is usually expressed in feet of head of substance flowing. Since the velocity w of the air is only constant over a differential length of pipe due to the increase of volume as the air expands, the differential drop in pressure is all that can be expressed.

$$- dh = \frac{b}{d} \frac{w^2}{2g} dl$$

In this: b is a constant and equal to

$$0.0124 + \frac{0.0274}{w} + \frac{0.00145}{d} + \frac{0.012^1}{dw} = 0.02 \text{ approximately. } \tag{43}$$

w = velocity in feet per second.

d = diameter of pipe in feet.

¹ Given by Green Economizer Co.

$g = 32.2$. ft. per sec. per sec.

dl = differential length in feet.

dh = differential drop in head in feet of air. (dh is negative because it decreases as dl increases.)

Now
$$\frac{p}{BT} dh = dp$$

$$\frac{p}{BT} = \text{weight of 1 cu. ft. of air}$$

and
$$w = \frac{MBT}{p} \times \frac{1}{F}$$

where F = area of pipe in square feet.
 M = weight of air per second in pounds.

Hence
$$- dp = \frac{p}{BT} \frac{b}{d} \frac{M^2 B^2 T^2}{p^2 F^2} \frac{dl}{2g}$$

or
$$-\int p dp = \frac{b}{d} \frac{M^2}{F^2} \frac{BT}{2g} \int dl$$

 (T is constant)

$$\frac{p_1^2 - p_2^2}{2} = \frac{b}{d} \frac{M^2}{F^2} \frac{BT}{2g} L = \frac{bM^2BT}{2g \frac{\pi^2}{16} d^5} L = b' \frac{M^2L}{d^5} \quad (44)$$

$$p_1^2 - p_2^2 = b'' \frac{M^2L}{d^5} \quad (45)$$

$$\text{Mean } b'' = 28$$

In the equations (44) and (45), p_1 = original pressure in pounds per square foot, p_2 = final pressure in pounds per square foot, L = length in feet in which drop occurs. The formula may be used to find p_2 , M , or F , depending on what quantities are given. The formula

$$p_1^2 - p_2^2 = b'' \frac{M^2L}{d^5}$$

can be changed to refer to the volume of free air at 60° F. instead of weight by dividing by the square of

$$\frac{53.35 \times 520}{14.7 \times 144} \text{ giving}$$

$$p_1^2 - p_2^2 = b''' \frac{V_f^2 L}{D^5} \quad (46)$$

Richards suggests $b''' = \frac{1}{2000}$, if

p_1 and p_2 = pressure in pounds per square inch.

V_f = cubic feet of free air per minute.

L = length of pipe in feet.

D = diameter of pipe in inches.

$$b''' = \frac{1}{2000}.$$

The expression (44) may be simplified as follows:

$$(p_1 - p_2) \left(\frac{p_1 + p_2}{2} \right) = \frac{b}{d} \frac{M^2}{F^2} \frac{BT}{2g} L$$

$$\frac{p_1 + p_2}{2} = p = \text{mean pressure}$$

$$\frac{BT}{p} = \text{mean volume of 1 lb.}$$

$$(p_1 - p_2) \frac{BT}{p} = \frac{b}{d} \frac{\left(M \frac{BT}{p} \right)^2}{F^2} \frac{L}{2g}$$

$$\text{or} \quad \text{Head drop in feet of air} = \frac{bLw_m^2}{d2g} \quad (47)$$

where w_m is the mean velocity since

$$\frac{MBT}{p} = V \quad \text{and} \quad \frac{V}{F} = w$$

Equation (47) is the formula used in hydraulics where the velocity is uniform.

Equations (44), (45) or (46) may be used to find the length of pipe for a given drop and quantity by weight or volume for a given pipe, or D if the allowable drop in a certain length at a given discharge is known, or lastly the drop for a given discharge through a certain pipe of given length. The value of b is obtained by successive approximations in the formula (43) if not known from the given conditions.

LOSS DUE TO LEAKAGE FROM TRANSMISSION LINE

The leakage from the transmission line may amount to a large percentage of the air delivered if the line is not tight throughout its entire length. The leakage through a number of small

holes is larger than one would expect. The amount of leakage is found by Fliegner's formulæ, depending on the pressure.

$$M = 0.53 \frac{F p_1}{\sqrt{T_1}} \text{ for } p_2 < 0.5 p_1$$

$$M = 1.060 F \sqrt{\frac{p_2(p_1 - p_2)}{T_1}} \text{ for } p_2 > 0.5 p_1$$

After M is found this may be reduced to free air by

$$V_{fl} = \frac{MBT_1}{p_a}$$

The loss is proportional to the quantity of air.

$$\text{Loss as per cent. of what should be obtained} = 100 \frac{V_{fl}}{V_f}$$

LOSS DUE TO THROTTLING

The friction action of the pipe line is the equivalent of throttling action and moreover in many cases air is stored in tanks under very high pressure to be used in engines or air motors at a reduced pressure after passing through a reducing pressure valve. The action of this reducing pressure valve is throttling action and hence the temperature of the air remains constant during this action; $p'_2 V'_2$ is therefore the same as $p_1 V_1$ or $p_a V_f$. The pressure has been reduced. The available energy should have been

$$W' = \frac{k}{k-1} p_1 V_1 \left[1 - \left(\frac{p'_1}{p_2} \right)^{\frac{k-1}{k}} \right]$$

but by throttling to p'_2 this is reduced to

$$W'' = \frac{k}{k-1} p_1 V_1 \left[1 - \left(\frac{p'_1}{p'_2} \right)^{\frac{k-1}{k}} \right]$$

or

$$\text{Loss due to throttling} = W' - W'' =$$

$$\frac{k}{k-1} p_1 V_1 \left[\left(\frac{p'_1}{p'_2} \right)^{\frac{k-1}{k}} - \left(\frac{p'_1}{p_2} \right)^{\frac{k-1}{k}} \right] \quad (48)$$

This reduction has been due to the reduction of the upper pressure to a point near the lower pressure.

GAIN FROM PREHEATING

If air at a pressure p'_2 and temperature T_1 is heated to the temperature T''_2 so that its volume is changed from V'_2 to V''_2 , the heat added will be

$$\begin{aligned} \Delta JQ &= JM c_p (T''_2 - T_1) \\ &= J c_p \frac{p'_2 (V''_2 - V'_2)}{B} \\ &= \frac{k}{k-1} p'_2 (V''_2 - V'_2) \end{aligned} \tag{49}$$

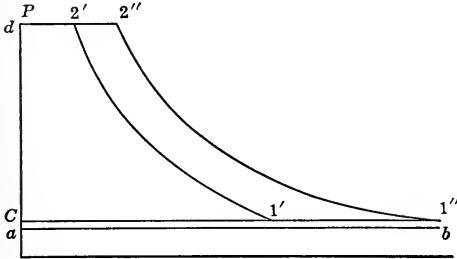

FIG. 54.—Gain from preheating air.

The increased work will be the area $2'2''1''1'$, or

$$\Delta W = \frac{k}{k-1} \left[p'_2 (V''_2 - V'_2) \right] \left[1 - \left(\frac{p'_1}{p'_2} \right)^{\frac{k-1}{k}} \right] \tag{50}$$

The efficiency of this heat used in preheating is therefore

$$\begin{aligned} \text{Eff.} = \frac{\Delta W}{\Delta Q} &= \frac{\frac{k}{k-1} \left[p'_2 (V''_2 - V'_2) \right] \left[1 - \left(\frac{p'_1}{p'_2} \right)^{\frac{k-1}{k}} \right]}{\frac{k}{k-1} p'_2 (V''_2 - V'_2)} \\ &= 1 - \left(\frac{p'_1}{p'_2} \right)^{\frac{k-1}{k}} \tag{51} \\ &= \frac{T''_2 - T''_1}{T''_2} \end{aligned}$$

If now this efficiency of preheating, $1 - \left(\frac{p'_1}{p'_2} \right)^{\frac{k-1}{k}}$, is higher than the overall efficiency of the system, *i.e.*, the ratio of the work of the air motor to the work required for the compressor, it will pay thermodynamically to preheat. Of course the necessity for a warm exhaust or the possibility of increasing the output of a

given quantity of air may make it advisable to use preheating, although the efficiency of this is not as great as the efficiency of the system.

POWER AND DISPLACEMENT OF AIR ENGINE OR MOTOR

In the case of complete expansion, the expression for work has been given.

$$\text{Work for single stage} = \frac{k}{k-1} p_a f V_f \left[1 - \left(\frac{p'_1}{p'_2} \right)^{\frac{k-1}{k}} \right] \quad (38)$$

$$\begin{aligned} \text{Work for single stage after preheating} = \\ \frac{k}{k-1} p'_2 f V''_2 \left[1 - \left(\frac{p'_1}{p'_2} \right)^{\frac{k-1}{k}} \right] \end{aligned} \quad (52)$$

$$\begin{aligned} \text{Work for } m\text{-stage expansion} = \\ \frac{mk}{k-1} p_a V_{ff} \left[1 - \left(\frac{p'_1}{p'_2} \right)^{\frac{k-1}{km}} \right] \end{aligned} \quad (40)$$

Since in these the volumes represent quantity per minute, the indicated horse-power may be found by dividing by 33,000 and this quantity multiplied by the mechanical efficiency of the motor or engine will give the delivered horse-power. This efficiency may be taken at 75 to 90 per cent.

If on the other hand the power required is known as well as the pressure available, the indicated power can be found from the assumed efficiency and then the work per minute. From the equations above, the volume of free air necessary for the engine or the amount of compressed air can be computed.

The next step is to find the displacement of the engine. If V_f is known, the amount of air per minute at the upper pressure is given by

$$V'_2 = \frac{p_a V_f}{p'_2} \quad (53)$$

If V'_2 is known this can be used to find V'_1 , the amount of air between the ends of the expansion and compression lines:

$$V'_1 = V'_2 \left(\frac{p'_2}{p'_1} \right)^{\frac{1}{k}} \quad (54)$$

$$\text{Displacement} = \frac{V'_1}{K_l} = \frac{V'_1}{\left[1 + l - l \left(\frac{p'_2}{p'_1} \right)^{\frac{1}{k}} \right]} \quad (55)$$

$$\text{If there is leakage,} \quad D = \frac{f V'_1}{K_l} \quad (56)$$

Now all the above determinations are for complete expansion and compression. If, however, there is incomplete expansion or compression other calculations must be made.

Let $\frac{1}{r}$ be the proportional value cut-off and x be the value of compression expressed in terms of the displacement and assume that there is a clearance of lD . The work is found as the area of the card after the pressures at 3 and 6 (Fig. 56) are found.

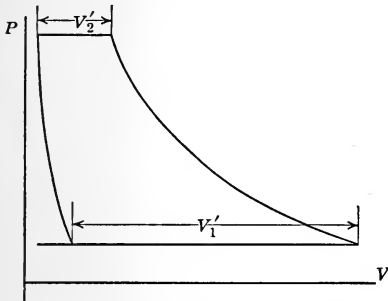

FIG. 55.—Diagram for air engine with complete expansion and compression.

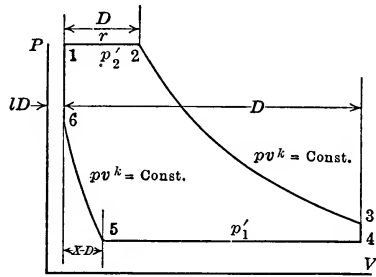

FIG. 56.—Diagram from air engine with incomplete expansion and compression.

$$p_3 = p'_2 \left[\frac{l + \frac{1}{r}}{l + 1} \right]^k \tag{57}$$

$$p_6 = p'_1 \left[\frac{l + x}{l} \right]^k \tag{58}$$

$$\text{Work per minute} = \frac{33000 \times D.H.P.}{\text{mech. eff.}} = \frac{1}{r} D p'_2 +$$

$$\frac{p_3(1 + l)D - p'_2 \left(l + \frac{1}{r} \right) D}{1 - k} - p'_1 [1 - x] D - \frac{p'_1(l + x)D - p_6 l D}{1 - k}$$

$$= D \left[\frac{1}{r} p'_2 - (1 - x) p'_1 + \frac{p_3(1 + l) - p'_2 \left(l + \frac{1}{r} \right) - p'_1(l + x) + p_6 l}{1 - k} \right] \tag{59}$$

In this equation D is the unknown quantity and may be found for any given power required. The quantity in brackets is the mean effective pressure of the card. The amount of free air

required for this motor is ascertained by determining the difference in the weights of air at 2 and 5 and then reducing this to volume. If there is leakage, D is made $D \div f$ in finding volume.

$$\begin{aligned}
 V_f &= \frac{MBT_1}{p_a} = \frac{BT_1}{p_a} \left[\frac{p'_2 \left(\frac{1}{r} + l \right) D}{BT_2} - \frac{p_5(l+x)D}{BT_5} \right] \\
 &= \frac{T_1 D}{p_a} \left[\frac{p'_2 \left(\frac{1}{r} + l \right)}{T_2} - \frac{p_5(l+x)}{T_5} \right] \quad (60)
 \end{aligned}$$

T_2 and T_5 are not definitely known on account of the action of the cylinder walls. On a test they could be determined, since the temperature at the beginning of compression is the same as that of the exhaust and from this the mass in the clearance space would be known. From the air supply the mass entering would be known and consequently the total mass at the point of cut-off or release. Since the pressures and volumes at these points are known, as well as the masses, the temperatures could be found. Although not strictly correct, T_5 will be assumed the same as T_3 and T_2 will be assumed equal to T_1 . This gives

$$V_f = \frac{D}{p_a} \left[p'_2 \left(\frac{1}{r} + l \right) - p_5 \left(\frac{1}{r} + l \right)^{k-1} (l+x) \right] \quad (61)$$

With either of the cases above if D is known the stroke and diameter can be found as in the case of the compressor.

Assume $2LN = 300$ to 700 or 1000 .

Assume N and find L .

Now $D = (F_h + F_c)LN$.

From this F_h and F_c may be found.

The output of the air motor is usually given in a problem and from this the i.h.p. may be found.

$$\frac{\text{h.p. output}}{\text{mech. eff.}} = \text{i.h.p.} \quad (62)$$

From this the size of the motor and the amount of free air may be found after the pressure limits and events of the stroke are assumed. After this is accomplished the drop in pressure in the supply line is found and finally the pressures, free air for the

compressor, size of compressor and the power to drive the same. The overall efficiency is found by

$$\text{Overall eff.} = \frac{\text{h.p. output of engine}}{\text{h.p. required to drive compressor}} \quad (63)$$

This efficiency is found to be about 40 per cent. when worked out, although with leaks a lower efficiency is obtained. To show various values of efficiency a number of problems will be worked out later.

FAN BLOWERS

The turbo compressors and fan blowers not only give a compression of the air but in addition the velocity of the air at discharge is so great that there is an additional term for the gain of kinetic energy. In the turbo compressors the cooling is practically continuous, although it may be considered as an m -stage compressor of a value of n of almost unity on account of the cooling effect of the metal and the water jacket. In this case the expression for work is

$$\text{Work} = p_1 V_1 \left[\frac{mn}{n-1} \left\{ 1 - \left(\frac{p_2}{p_1} \right)^{\frac{n-1}{mn}} \right\} + \frac{1}{BT} \frac{w^2}{2g} \right] \quad (64)$$

For the fan blower the action is so rapid and the path so short that the action is assumed adiabatic and the expression is

$$\text{Work} = p_1 V_1 \left\{ \frac{k}{k-1} \left[1 - \left(\frac{p_2}{p_1} \right)^{\frac{k-1}{k}} \right] + \frac{1}{BT} \frac{w^2}{2g} \right\} \quad (65)$$

In this p_2 and p_1 differ by a small quantity.

GOVERNING

The fan and turbo compressor are of value because the quantity of air may be varied with the need, the pressure changing with the quantity and the power changing within known limits so that motors may be provided. With displacement compressors working at a fixed pressure, the simple way of changing the quantity is to change the speed of the compressor. This may be accomplished with steam engine drives by a slight throttling of the steam. The point of cut-off is not changed and the pressure is only slightly changed because for a given delivery pressure for the air a definite steam pressure is required to give sufficient area on the steam card. The slight increase of pressure will overcome the friction

and speed up the machine. When, however, the speed of the motor cannot be varied, as is the case with certain electric motors, the varying demand for air must be met in other ways. Among the ways suggested to care for a varying quantity of air the following may be mentioned: (a) **delayed closing of inlet valve**, (b) **delayed closing of discharge valves**, (c) **throttling air on suction** and (d) **changing clearance**. These methods are all under the control of the governor. All except method (c) mean no change in efficiency. Fig. 57 shows methods (a), (b) and (c)

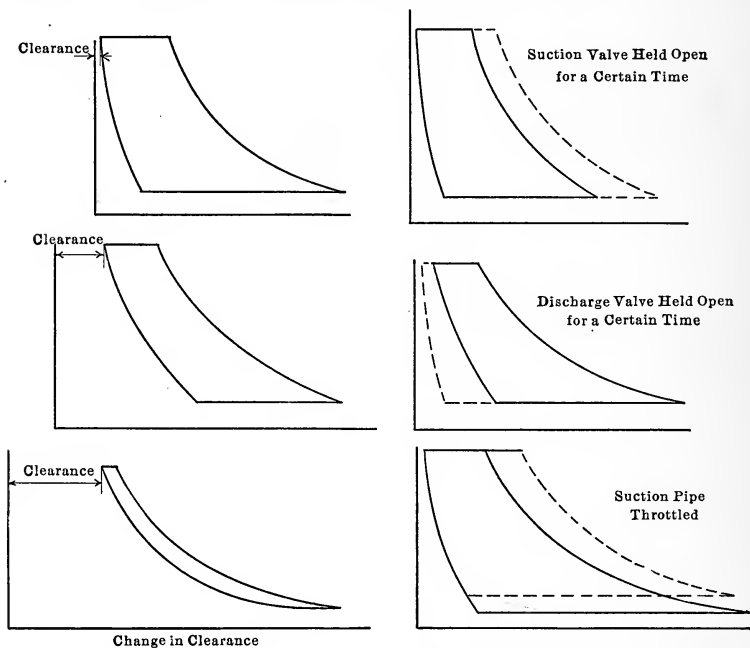

FIG. 57.—Methods of changing the discharge from an air compressor of fixed speed.

as well as three cards for three different clearances. The clearance is varied by automatically connecting different chambers to the cylinder heads as the pressure rises. This is controlled by the governor as the pressure rises, necessitating a reduction in the quantity of air; the increase of clearance will cut down the quantity. When compressors are to be operated at different pressures, the work of the steam cylinder is controlled by a **throttle governor**, a **variable cut-off governor** or by a **Meyer valve gear**.

MOTORS

The engines using compressed air may be of the regular form of engine or its equivalent. Fig. 58 shows the section through a **Little David riveter** of the Ingersoll Rand Co. In this the **throttle valve A** is controlled by the **handle B** which is pressed by the thumb of the operator allowing air to enter. The **valve C**

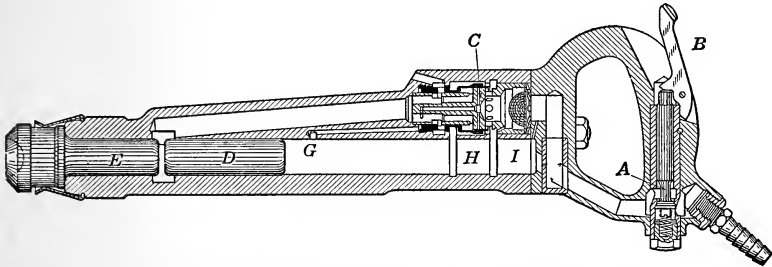

FIG. 58.—Little David riveter of Ingersoll-Rand Co.

allows air to enter behind the piston *D* which is driven at a high speed against the **shank E** which drives the rivet. The valve *C* shown in black admits air to the groove at *I* and exhaust takes place through the passage running from the left end of the piston. After passing through passages in the valve the exhaust leaves through the outlet to the left of *C*. When *G* is uncovered air

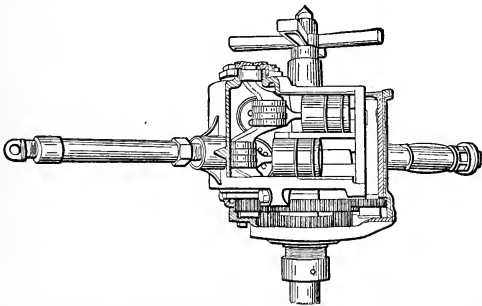

FIG. 59.—Ingersoll-Rand air drill (Little David).

rushes through a small port and actuates the valve so that air is cut off from *I* and the port *H* is connected to outlet and the air to the right of the piston is discharged. A small port at this time discharges air into the large exhaust passage which is now cut off from the atmosphere and this forces the piston to the right.

When the piston passes *H* the air remaining to the right and an amount which constantly leaks through a passage to the right of *I* is compressed, cushioning the piston. The increase of pressure here, and that due to a leak into the groove *I* after this is covered by the piston, causes the valve to reverse and the action to be repeated.

Fig. 59 shows the construction of a **drill** which is the equivalent of four single-acting engines with rotary valves worked from the shaft while Fig. 60 shows a section through a **rotary reamer or drill**. This is a **rotary engine**. Air is admitted at *A* and causes the diaphragm or plate *B* to turn on the axis *C*.

In Fig. 61 a preheater is shown. In this the passage of the air through the hollow portions of the heating surface raises the temperature to a high point. The fuel may be coal, oil or gas.

The arrangement and amount of

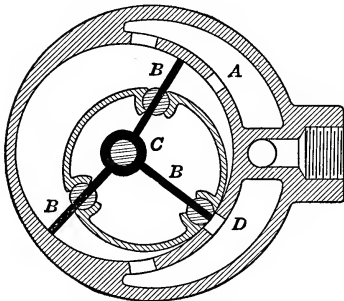

FIG. 60.—Rotary air drill.

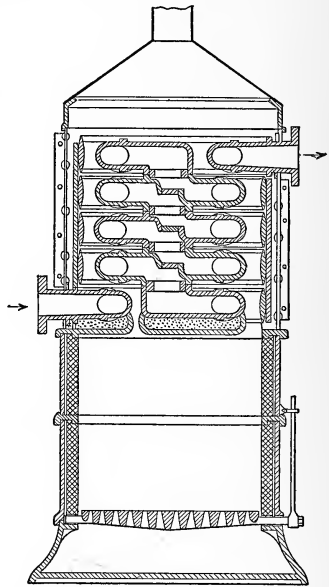

FIG. 61.—Sullivan air preheater.

surface in the intercooler is fixed by the principles of Chapter III, and will be discussed later in connection with a definite design.

LOSSES IN TRANSMISSION

The various losses discussed are shown in Fig. 62.

abcd = unavoidable loss due to two staging. This may be eliminated if a two-stage engine is used.

efgd = loss due to leakage in compressor.

gfh = loss due to change of line.

$hfji$ = loss due to cooling.
 $ijkl$ = loss due to leakage in line.
 $knop - mnql$ = loss due to throttling.
 $mrst$ = loss due to high back pressure.

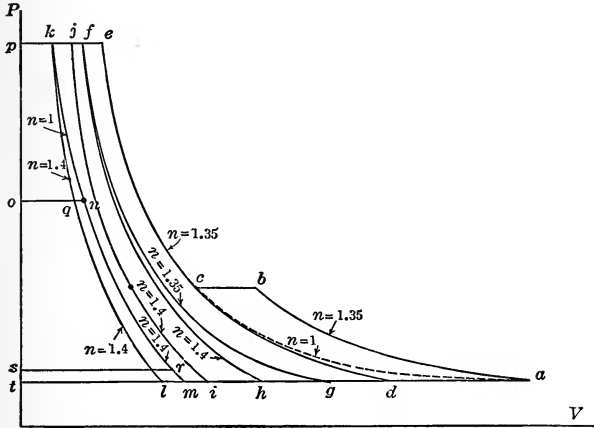

FIG. 62.—Diagram showing various losses in air transmission.

LOGARITHMIC DIAGRAMS

Before solving problems it will be well to consider the construction of polytropics on logarithmic coordinates. If a curve of the form $pV^n = \text{const.}$ be plotted on the coordinates $\log p$ and $\log V$ it is found that the equation above takes the form

$$\log p + n \log V = \text{const.}$$

This is of the form $x + ny = \text{const.}$, or the curve becomes a straight line and the value of n is the slope of the curve since

$$\frac{dx}{dy} = -n$$

If the coordinates of p and V of a curve are plotted logarithmically with logarithmic coordinates and the points lie in a straight line, as in Fig. 63, the curve must be of the form $pV^n = \text{const.}$ and the slope of the line is the value of n . The value of n in the figure is to be

$$n = 1.4$$

In this figure the value of the logarithm extends from 0 to 1 and the numbers from 1 to 10, but the figure is constructed

beyond that limit since the same variation in logarithm changes the numbers from 10 to 100, 100 to 1000, etc., or 1 to 0.1, 0.1 to 0.01, etc.

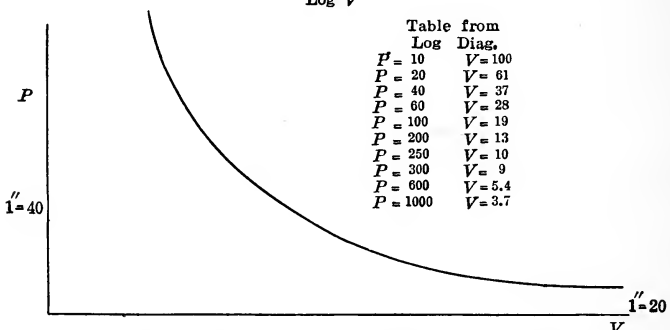
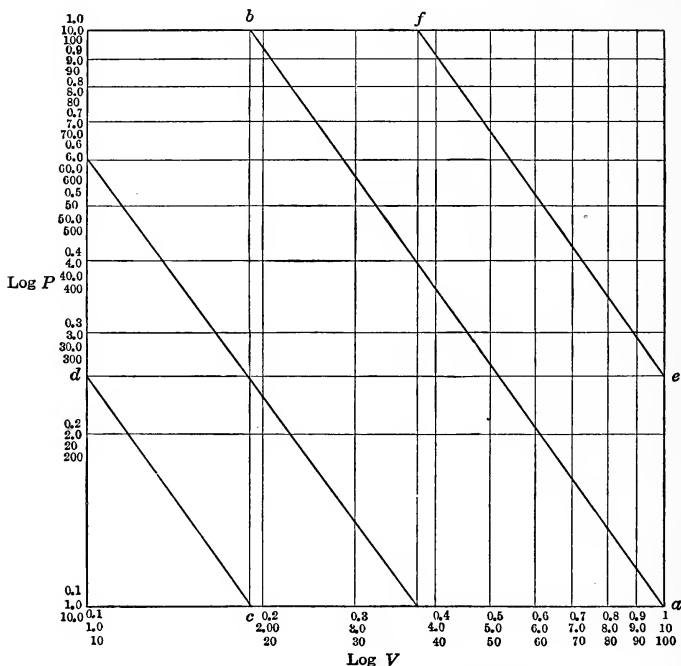

FIG. 63.—Logarithmic diagram with repeated coordinates for plotting $pV^{1.4} = \text{const.}$

If in the figure from b at the end of ab , the vertical to c is drawn and then cd is drawn parallel to ab , and after taking d to e and drawing ef with one following fg , a series of lines may be put on a single figure which would require a much larger figure if a single

line were drawn as in Fig. 64. Fig. 64 is less confusing than Fig. 63, but it requires much more space.

Such figures as the above are of value in constructing curves of expansion. If on a logarithmic diagram through the points $\log p_1$ and $\log V_1$, a line inclined at $n = 1.35$ be drawn, the values

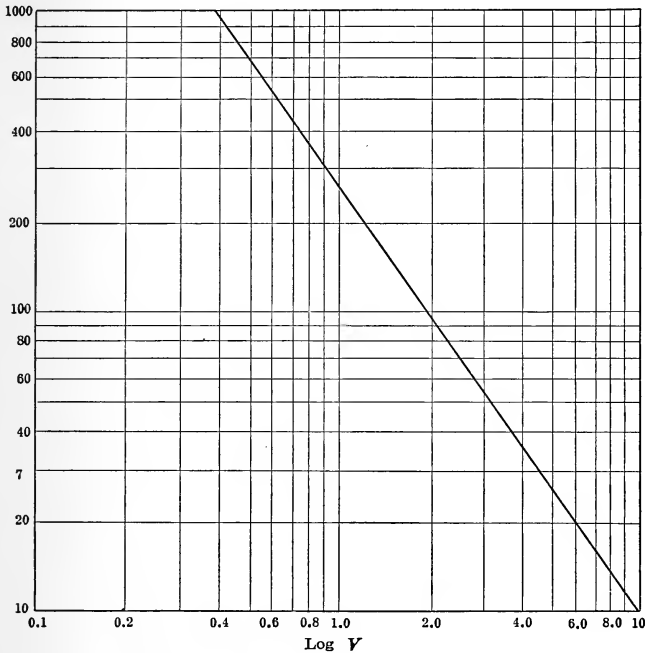

FIG. 64.—Logarithmic diagram with continued coordinates.

of p and V for any point may be found and the pV curve drawn with simplicity.

To aid in computations of many of the above quantities charts and diagrams have been devised from which results may be obtained rapidly. A set of diagrams arranged by Professor C. R. Richards and Mr. J. A. Dent, based on temperature entropy logarithmic diagrams, is of great value. See Bulletin 63 of the Engineering Experiment Station, University of Illinois.

PROBLEMS

To apply the above formulæ, a problem will be assumed as follows: Ten 5-h.p. air motors are to operate at 200 r.p.m. between 60.3 lbs. gauge pressure and 0.3 lb. gauge back pressure. Find the size of the motors if the

piston speed is 200 ft. per minute and find the amount of free air required to drive these assuming a 3 per cent. leakage. Assume first that the compression and expansion are complete with a 5 per cent. clearance and second assume a cut-off at 0.35 stroke and compression at 0.1 stroke with 5 per cent. clearance. Compression of this air is to take place in a two-stage air compressor from -0.2 lb. gauge pressure to 135.3 lbs. gauge pressure. The compressor is 3000 ft. from the motors and the drop in the supply main is to be 4 lbs. Find the size of the main. There are fifty $\frac{1}{2}$ -in. holes in the main; find the leakage. The air temperature is 70° F. and the available water is at 60° F. The leakage in the compressors is 3 per cent. Find the air to be taken into the compressor to cover all leakages. Find the various efficiencies, losses and constants of the system. Would it be advisable to preheat the air to 350° F.? In this problem the work will be done by the use of a 12-in. slide rule of Log. Log. form.

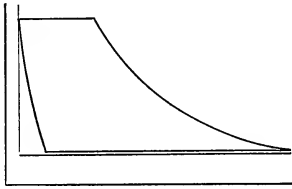

FIG. 65.—Indicator card for air engine with complete expansion and compression.

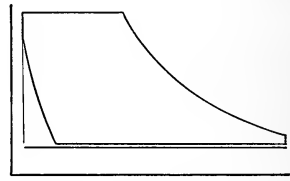

FIG. 66.—Indicator card for an engine with incomplete expansion and compression.

Problem 1.—Indicated horse-power of one motor.

$$\text{I.h.p.} = \frac{\text{h.p.}}{\text{eff.}} = \frac{5}{0.80} = 6.25$$

Friction 1.25 h.p.

Problem 2.—Displacement and free air for two cases.

(a) Complete expansion and compression.

$$\begin{aligned} 6.25 \times 33,000 &= \frac{1.4}{1.4 - 1} 14.7 \times 144 \times 0.97 V_f \left[1 - \left(\frac{14.7 + 0.3}{14.7 + 60.3} \right)^{0.4} \right] \quad (40) \\ &= 3.5 \times 2118 \times 0.97 V_f [1 - 0.631] \end{aligned}$$

$$V_f = 78 \text{ cu. ft. per minute}$$

$$V'_2 = \frac{14.7 \times 78}{75} = 15.26 \quad (53)$$

$$V'_1 = 15.26 \times \left(\frac{75}{15} \right)^{\frac{1}{1.4}} = 48 \quad (54)$$

$$K_l = 1 + 0.05 - 0.05 \times \left(\frac{75}{15} \right)^{\frac{1}{1.4}} = 1.05 - 0.158 = 0.892 \quad (30)$$

$$D = \frac{0.97 \times 48}{0.892} = 52 \text{ cu. ft. per minute.} \quad (56)$$

(b) Incomplete expansion and compression.

$$p_3 = 75 \left[\frac{0.05 + 0.35}{0.05 + 1} \right]^{1.4} = 75 \times \frac{1}{3.86} = 19.4 \text{ lbs. per square inch} \quad (57)$$

$$p_6 = 15 \left[\frac{0.05 + 0.1}{0.05} \right]^{1.4} = 15 \times 4.66 = 69.9 \text{ lbs. per square inch} \quad (58)$$

$$\text{M.e.p.} = 0.35 \times 75 - 0.9 \times 15 + \frac{19.4 \times 1.05 - 75 \times 0.4 - 15 \times 0.15 + 69.9 \times 0.05}{-0.4} \quad (59)$$

$$= 26.25 - 13.5 + 21 = 33.75 \text{ lbs. per square inch}$$

$$6.25 \times 33,000 = D \times 144 \times 33.75$$

$$D = 42.5 \text{ cu. ft. per minute}$$

$$V_f = \frac{42.5}{14.7 \times 144} \left[144 \times 75 \times 0.4 - 15 \times 144 \left(\frac{1.05}{0.4} \right)^{0.4} \times 0.15 \right] \quad (61)$$

$$= 2.89 \left[30.0 - 3.3 \right] = 77.2 \text{ cu. ft. per minute.}$$

If leakage is considered

$$V_f = \frac{77.2}{0.97} = 79.5 \text{ cu. ft.}$$

The loss in power due to leakage is $\left(\frac{6.25}{0.97} - 6.25 \right) = 0.19 \text{ h.p.}$

It is seen that although the displacement is larger for the complete expansion arrangement the amount of free air is slightly less. The difference between the two cases is not great.

Problem 3.—Size of motors.

(a) and (b). $N = 200$

Assume $2LN = 200$

$$\therefore L = \frac{1}{2} \text{ ft.} = 6 \text{ in.}$$

$$(a) D = 52 = (A_h + A_c) \times 200 \times \frac{1}{2}$$

If the areas are equal

$$A = \frac{52}{200} \text{ sq. ft.}$$

$$= \frac{52 \times 144}{200} = 37.4 \text{ sq. in.}$$

Assuming a 1-in. piston rod and tail rod

$$A_{cyl.} = 37.4 + 0.7854 = 38.2 \text{ sq. in.}$$

$$d = 6.95 \text{ in.} = 7 \text{ in.}$$

Cylinder 7 in. \times 6 in.

(b) $D = 42.5 \text{ cu. ft.} = 2 \times 200 \times \frac{1}{2} \times A$

$$A = \frac{42.5}{200} \times 144 = 30.6 \text{ sq. in.}$$

$$A_{cyl.} = 30.6 + 0.7854 = 31.4 \text{ sq. in.}$$

$$d = 6.33 \text{ in.}$$

Cylinder 6.33 in. \times 6 in.

Problem 4.—Leakage from pipe line.

Pressure at one end = 135.3 + 14.7 = 150

Assumed pressure for leakage = 150

$$M = 0.53 \times \frac{50}{4} \times \frac{\pi}{32 \times 32} \times \frac{150}{\sqrt{460 + 70}}$$

$$= 0.132 \text{ lbs. per second}$$

$$V_{fl} = \frac{60 \times 0.132 \times 53.35 \times 530}{14.7 \times 144} = 105 \text{ cu. ft. per minute.}$$

Problem 5.—Total free air assuming case of complete expansion motors.

(a) Air for motor = 78 cu. ft. per minute.

(b) Leakage air = 105 cu. ft. per minute.

(c) Total delivered free air = 885 cu. ft. per minute.

(d) Total free air required for compressor = $\frac{885}{0.94} = 942$ cu. ft. per minute.

(0.94 is leakage factor for two stages.)

Problem 6.—Diameter of pipe line to carry air.

$$M = \frac{885 \times 14.7 \times 144}{60 \times 53.35 \times 530} = 1.10 \text{ lbs. per second.}$$

For first approximation $b = 0.02$

$$\left(\frac{150^2 - 146^2}{2} \right) 144^2 = \frac{0.02 \times 1.1^2 \times 53.35 \times 530}{2 \times 32.2 \times \frac{\pi^2}{16} \times d^5} \times 3000 \quad (44)$$

$$d^5 \text{ in inches} = d^5 \text{ in feet} \times 12^5 = 1050$$

$$d = 4.02 \text{ in.}; \text{ use 4-in. pipe.}$$

b should then be checked

$$w = \frac{1.1 \times \frac{53.35 \times 530}{148 \times 144}}{\frac{16}{144} \times 0.7854} = 16.7 \text{ ft. per second.}$$

$$b = 0.0124 + \frac{0.0274}{16.7} + \frac{0.00145}{\frac{1}{2}} + \frac{0.012}{16.70 \times \frac{1}{2}} \quad (43)$$

$$= 0.0124 + 0.0016 + 0.0044 + 0.0020$$

$$= 0.0204$$

The value of 0.02 is close.

Using equation (46)

$$150^2 - 146^2 = \frac{885^2 \times 3000}{2000 \times D^5} \quad (46)$$

$$D^5 = 990$$

$$D = 3.97 \text{ in. or 4 in.}$$

The drop in pressure will not be 4 lbs. if a 4-in. pipe is used with $b = 0.0204$

$$p_1^2 - p_2^2 = \frac{2}{144^2} \times \frac{0.0204 \times 1.1^2 \times 53.35 \times 530}{2 \times 32.2 \times \frac{\pi^2}{16} \times \left(\frac{4}{12} \right)^5} \times 3000 \quad (44)$$

$$p_2^2 = 22,500 - 1238 = 21,262$$

$$p_2 = 145.8 \text{ lbs.}$$

$$\therefore \text{Drop} = 4.2 \text{ lbs.}$$

If a one-third increase in this is assumed a drop of 6 lbs. will be cared for.

Problem 7.—Loss due to throttling from 150 lbs. to 144 lbs. abs.

$$\begin{aligned} \text{Loss} &= \frac{1.4}{0.4} 14.7 \times 144 \times 885 \left[\left(\frac{15}{144} \right)^{\frac{0.4}{1.4}} - \left(\frac{15}{150} \right)^{\frac{0.4}{1.4}} \right] \quad (48) \\ &= 6,550,000[0.524 - 0.518] \\ &= 39,300 \text{ ft.-lbs. per min.} = 1.19 \text{ h.p.} \end{aligned}$$

Problem 8.—Loss due to throttling from 150 lbs. to 75 lbs. abs.

$$\begin{aligned} \text{Loss} &= 6,550,000 \left[\left(\frac{15}{75} \right)^{\frac{0.4}{1.4}} - 0.518 \right] \quad (48) \\ &= 6,550,000[0.631 - 0.518] \\ &= 6,550,000[0.113] \\ &= 740,000 \text{ ft.-lbs. per min.} = 22.5 \text{ h.p.} \end{aligned}$$

Loss if leakage occurs at higher pressure

$$= 22.5 \times \frac{780}{885} = 19.8 \text{ h.p.}$$

Problem 9.—Loss due to cooling from T_2 to T_1 .

$$\begin{aligned} T_2 &= 530 \left(\frac{150}{14.5} \right)^{\frac{0.35}{1.35 \times 2}} \quad (26) \\ &= 530(10.33)^{\frac{1}{7.7}} \\ &= 530 \times 1.355 = 718^\circ \text{ F. abs.} = 258^\circ \text{ F.} \end{aligned}$$

$$\begin{aligned} \text{Loss} &= \frac{1.4}{0.4} \times 0.94 \times 942 \times 14.7 \times 144 \left[\left(\frac{150}{14.5} \right)^{\frac{0.35}{2 \times 1.35}} - 1 \right] \left[1 - \left(\frac{15}{150} \right)^{\frac{0.4}{1.4}} \right] \quad (41) \\ &= 6,550,000[1.355 - 1][1 - 0.518] \\ &= 1,122,000 \text{ ft.-lbs. per min.} = 34.1 \text{ h.p.} \end{aligned}$$

The use of values previously computed reduces the amount of computation.

Problem 10.—Work on two-stage compression and intermediate pressure.

$$\begin{aligned} \text{Work} &= \frac{2 \times 1.35}{0.35} \times 14.7 \times 144 \times \frac{885}{0.955} \left[1 - \left(\frac{150}{14.5} \right)^{\frac{0.35}{2.7}} \right] \quad (20) \\ &= 15,120,000[1 - 1.355] \\ &= -5,370,000 \text{ ft.-lbs. per min.} = 162.7 \text{ h.p.} \\ 0.955 &= \frac{0.94 + 0.97}{2} = \text{leakage factor for work on two stages} \\ p'_2 &= \sqrt{150 \times 14.5} = 46.6 \text{ lbs. per sq. in. abs.} \quad (19) \end{aligned}$$

Problem 11.—Work on single stage.

$$\begin{aligned} \text{Work} &= \frac{1.35}{0.35} \times 14.7 \times 144 \times \frac{885}{0.97} \left[1 - \left(\frac{150}{14.5} \right)^{\frac{0.35}{1.35}} \right] \quad (7) \\ &= 7,470,000[1 - 1.833] \\ &= 6,220,000 \text{ ft.-lbs. per min.} = 188.5 \text{ h.p.} \end{aligned}$$

Problem 12.—Saving due to double staging.

$$\text{Gain} = 188.5 - 162.7 = 25.8 \text{ h.p.}$$

Problem 13.—Saving due to jacket if on single stage (16).

$$\begin{aligned} \text{Gain} &= 14.7 \times 144 \times \frac{885}{0.97} \left\{ \frac{1.4}{0.4} \left[1 - \left(\frac{150}{14.5} \right)^{\frac{0.4}{1.4}} \right] - \frac{1.35}{0.35} \left[1 - \left(\frac{150}{14.5} \right)^{\frac{0.35}{1.35}} \right] \right\} \\ &= 1,930,000 \{ 3.5[1 - 1.95] - 3.86[1 - 1.833] \} \\ &= 1,930,000 \{ -3.32 + 3.218 \} \\ &= -197,000 \text{ ft.-lbs. per min.} = 5.98 \text{ h.p.} \end{aligned}$$

Problem 14.—Saving due to jacket if on two-stage compressor.

$$\begin{aligned} \text{Gain} &= 1,950,000 \{ 7[1 - (1.95)^{\frac{1}{2}}] - 7.72[1 - (1.833)] \} \\ &= 126,500 \text{ ft.-lbs. per min.} = 3.84 \text{ h.p.} \end{aligned}$$

Problem 15.—Unavoidable loss in two staging (36).

$$\begin{aligned} \text{Loss} &= \frac{1.35}{0.35} \times 14.7 \times 144 \times \frac{885}{0.955} \left[1 - \left(\frac{150}{14.5} \right)^{\frac{0.35}{2.7}} \right] \left[1 - \left(\frac{14.5}{150} \right)^{\frac{0.35}{2.7}} \right] \\ &= -7,560,000 [0.355] \left[1 - \frac{1}{1.355} \right] \\ &= -705,000 \text{ ft.-lbs. per min.} = 21.25 \text{ h.p.} \end{aligned}$$

Problem 16.—Loss due to change in expansion line of engine from n to k , starting from point at end of compression.

$$\begin{aligned} \text{Loss} &= p_2 V_2 \left\{ \frac{n}{n-1} \left[1 - \left(\frac{p_1}{p_2} \right)^{\frac{n-1}{n}} \right] - \frac{k}{k-1} \left[1 - \left(\frac{p_1}{p_2} \right)^{\frac{k-1}{k}} \right] \right\} \quad (42) \\ &= p_1 V_1 \frac{T_2}{T_1} \left\{ \right\} = p_1 V_1 \left(\frac{p_2}{p_1} \right)^{\frac{n-1}{2n}} \left\{ \right\} \\ &= 14.7 \times 144 \times 885 \times 1.355 \left\{ 3.86 \left[1 - \frac{1}{1.833} \right] - 3.5 \left[1 - \frac{1}{1.95} \right] \right\} \\ &= 2,540,000 \{ 1.755 - 1.706 \} \\ &= 124,500 \text{ ft.-lbs. per min.} = 3.78 \text{ h.p.} \end{aligned}$$

Problem 17.—Loss due to high back pressure in engine.

$$\begin{aligned} \text{Loss} &= \frac{k}{k-1} p_1 V_1 \left[1 - \left(\frac{p_1}{p_2} \right)^{\frac{k-1}{k}} - 1 + \left(\frac{p_1'}{p_2} \right)^{\frac{k-1}{k}} \right] \\ &= \frac{1.4}{0.4} \times 780 \times 14.7 \times 144 [0.632 - 0.625] \\ &= 40,500 \text{ ft.-lbs. per min.} = 1.23 \text{ h.p.} \end{aligned}$$

Problem 18.—Loss due to leakage in compressor.

$$\begin{aligned} \text{Loss} &= \text{available work without leakage} - \text{available work with leakage} \\ &= [\text{work of compression} - \text{unavoidable loss}] \times [1 - \text{leakage factor}] \\ &= [162.7 - 21.25][1 - 0.955] = 6.38 \text{ h.p.} \end{aligned}$$

Problem 19.—Loss due to leakage in line.

$$\begin{aligned} \text{Loss} &= [\text{work of compression} - \text{unavoidable loss} - \text{loss} \\ &\quad \text{due to compressor leakage} - \text{loss due to change} \\ &\quad \text{of exponent} - \text{loss due to cooling}] \frac{\text{leakage volume}}{\text{total volume}} \\ &= [162.7 - 21.25 - 6.38 - 3.78 - 34.1] \frac{105}{885} \\ &= 11.5 \text{ h.p.} \end{aligned}$$

Problem 20.—Power to drive compressor.

$$\begin{aligned} \text{Power} &= \frac{\text{ind. power}}{\text{mech. eff.}} = \frac{162.7}{0.90} = 180.8 \text{ h.p.} \\ \text{Friction loss} &= 180.8 - 162.7 = 18.1 \text{ h.p.} \end{aligned}$$

Problem 21.—Power of motor for compressor.

$$\begin{aligned} \frac{180.8}{0.90} &= 200.1 \text{ h.p.} \\ \text{Motor loss} &= 200.1 - 180.8 = 19.3 \text{ h.p.} \end{aligned}$$

TABLE OF POWER

		H.p.	Percentage
Power supplied motors.....		200.1	100.00
Loss motors.....		19.3	9.6
Power supplied compressor.....		180.8
Loss compressor.....		18.1	9.0
Power supplied air.....		162.7
Unavoidable loss.....	21.25	10.6
Loss from leakage in compressor.....	6.38	3.2
Loss due to change from <i>n</i> to <i>k</i>	3.78	1.9
Loss due to cooling after delivery.....	34.1	17.1
Available power supplied line.....		97.2
Loss due to leakage in line.....	11.5	5.7
Loss due to throttling to 75 lbs.....	19.8	9.9
Available power at engine.....		65.9
Loss due to high back pressure.....	1.23	0.6
Loss due to leakage 3 per cent. of 65.9..	1.98	1.0
Available indicated work.....		62.70
Amount loss in engine 20 per cent....		12.54	6.3
Amount delivered.....		50.20	25.1
			100.00
Saving due to jacket.....		3.84	1.9
Saving by double staging.....		25.8	12.9

It is to be noted that there is 9.9 per cent. loss due to throttling and 5.7 per cent. due to leakage. These might be saved, giving the overall efficiency about 40 per cent. in place of 25 per cent. The low efficiency has been due to the leakage from line and throttling. In good installations 40 per cent. overall efficiency might be reached.

Problem 22.—Heat removed by jacket (15).

$$\begin{aligned} \text{Heat} &= \frac{1}{1 - \left(\frac{14.5}{150}\right)^{\frac{1}{2.7}}} \left[\frac{1.35 - 1.40}{-(0.4)(0.35)} \right] \left[941 \times 14.7 \times 144 \right] \\ & \qquad \qquad \qquad \left[1 - \left(\frac{150}{14.5}\right)^{\frac{0.35}{2.7}} \right] \\ &= -1.73 \times \frac{0.05}{0.14} \times 13,830 \times 144 \times 0.355 \\ &= -436,000 \text{ ft.-lbs. per min.} \\ &= -561 \text{ B.t.u. per min.} \end{aligned}$$

Problem 23.—Heat removed by intercooler (28).

$$\begin{aligned} \text{Heat} &= -\frac{1.4}{0.4} \left(\frac{885}{0.97} \times 14.7 \times 144 \right) \left[1 - \left(\frac{150}{14.5}\right)^{\frac{0.35}{2.7}} \right] \\ &= +2,400,000 \text{ ft.-lbs. per min.} \\ &= 3090 \text{ B.t.u. per min.} \end{aligned}$$

Problem 24.—Water for jacket.

Assume water rises from 75° to 90° F. in jacket.

$$G = \frac{561}{90 - 75} = 37.4 \text{ lbs. per min.}$$

Problem 25.—Water for intercooler.

Assume rise in temperature from 60° to 75° F.

$$G = \frac{3090}{75 - 60} = 206 \text{ lbs. per min.}$$

Problem 26.—Mean Δt , assuming counter current flow from 60° to 75° F. for water and 70° to 258° F. for air, using Rensselaer formula.

$$\Delta t_1 = 258 - 75 = 183^\circ \text{ F.}$$

$$\Delta t_2 = 70 - 60 = 10^\circ \text{ F.}$$

$$\text{Mean } \Delta t = \left[\frac{\frac{1}{2}(183 - 10)}{(183)^{\frac{1}{2}} - 10^{\frac{1}{2}}} \right]^{\frac{3}{2}} = \left[\frac{57.7}{3.53} \right]^{\frac{3}{2}} = 66^\circ \text{ F.}$$

Note that this is quite different from $\frac{183 + 10}{2} = 97^\circ \text{ F.}$

Problem 27.—Surface required and arrangement.

Assume water velocity = 3 ft. per sec.

Assume air velocity = 10 ft. per sec.

$$\text{Value of } K = 126 \times \frac{46.6 \times 144 \times 1}{53.35(164 + 460)} \times \frac{(10 - 1.75)^{0.4}}{66^{\frac{1}{2}}} \times 3^{\frac{1}{2}} = 16.7$$

(44) Ch. I

$$\text{Surface} = \frac{3090 \times 60}{16.7 \times 66} = 169 \text{ sq. ft.}$$

Arrangement of $\frac{3}{4}$ -in. tubes 12 ft. long with water inside.

$$\text{Area of 1 tube} = \frac{\pi}{12} \times \frac{3}{4} \times 12 = 2.35 \text{ sq. ft.}$$

$$\text{No. of tubes} = \frac{169}{2.35} = 72 \text{ tubes.}$$

No. of tubes in one nest.

$$\text{Area of inside of tube} = \frac{\pi}{4} \times \left(\frac{3}{4} - \frac{1}{16}\right)^2 \times \frac{1}{144} = 0.00258 \text{ sq. ft.}$$

Amount of water = 206 lbs. per min.

Velocity of water = 3 ft. per sec., 180 ft. per min.

$$\text{No. tubes in parallel} = \frac{206}{64.5 \times 180 \times 0.00258} = 7 \text{ tubes.}$$

This means 10 nests, or the water will run from 7 tubes to 7 tubes so as to give a path of 120 ft. in cooler.

$$\text{Volume of air per min.} = (942 \times 0.97) \frac{14.7}{46.6} \times \frac{614}{520} = 340 \text{ cu. ft.}$$

$$\text{Area for air} = \frac{340}{10 \times 60} = 0.565 \text{ sq. ft.}$$

Suppose the 7 tubes are made in a case so that the air may pass along. Area of passage 0.565 sq. ft. = 81 sq. in. To this the area of seven $\frac{3}{4}$ -in. tubes or 3 sq. in. will be added giving 84 sq. in. for passage of air.

Problem 28.—Size of compressors at 80 r.p.m. with 400 ft. piston speed.

$$\begin{aligned} K_1 &= 1 + 0.05 - 0.05 \left(\frac{150}{14.5}\right)^{\frac{1}{2.7}} \\ &= 0.932 \end{aligned}$$

$$\text{Low-pressure displacement} = \frac{885}{0.94 \times 0.932} = 1010 \text{ cu. ft. per min.}$$

$$1010 = 400 A_{\text{mean}}$$

$$A_{\text{net}} = 2.52 \text{ sq. ft.} = 388 \text{ sq. in.}$$

Assume a 3-in piston rod; $A = 7.06 \text{ sq. in.}$

$$A_{\text{gross}} = 363 \text{ sq. in.}$$

$$d_{\text{cyl.}} = 21.5 \text{ in.}$$

$$L = \frac{400}{2 \times 80} = 2\frac{1}{2} \text{ ft.}$$

Size of compressor 21.5 in. \times 30 in.

High pressure displacement.

Intermediate pressure = $\sqrt{150 \times 14.5} = 46.6 \text{ lbs.}$

$$D = \frac{885}{0.97 \times 0.932} \times \frac{14.7}{46.6} = 308 \text{ cu. ft.}$$

$$\text{Stroke} = 30 \text{ in.}$$

$$\text{Area net} = \frac{308}{400} = 0.77 \text{ sq. ft.} = 111.0 \text{ sq. in.}$$

$$\text{Area gross} = 111.0 + 7.06 = 118.06$$

$$d_{\text{cyl.}} = 12.3 \text{ in.}$$

Size of high-pressure compressor 12.3 in. \times 30 in.

Problem 29.—The efficiency of preheating is

$$\text{Eff.} = 1 - \left(\frac{15}{75}\right)^{\frac{0.4}{1.4}} = 1 - 0.631 = 0.369$$

With the leakage and throttling giving an efficiency of 25 per cent. on output or $(25 + 6.3) = 31.3$ per cent. on indicated work of engine it is

seen that this would pay. If there had been no throttling and the air were at a 150-lb. absolute pressure the efficiency would be

$$\text{Eff.} = 1 - \left(\frac{15}{150}\right)^{\frac{0.4}{1.4}} = 1 - 0.518 = 0.482$$

This, being better than 40 per cent., would pay. In most cases pre-heating will pay. It is well to note in passing that the efficiency of pre-heating depends on the range of pressure.

TOPICS

Topic 1.—What are the different methods of compressing air? Sketch machines for this purpose. Under what conditions is each used?

Topic 2.—Explain the construction of a two-stage air compressor and give the reasons for the use of such apparatus. What is the purpose of the intercooler? Why is moisture apt to collect in the air space of the intercooler? How is it removed? What is the peculiar form of inlet valve used on the low-pressure piston?

Topic 3.—For what reason is air for a compressor taken from the atmosphere and not from the engine room? Why are water-jackets used? Explain the action of the Taylor hydraulic air compressor.

Topic 4.—Derive the expression:

$$\text{Work} = \frac{n}{n-1} p_a V_f \left[1 - \left(\frac{p_2}{p_1}\right)^{\frac{n-1}{n}} \right]$$

Topic 5.—What is the effect of clearance? Prove this. Derive the expression for the clearance factor.

Topic 6.—Explain what is meant by volumetric efficiency. Derive the formula for true volumetric efficiency in terms of the leakage and clearance. Show how to find the horse-power to drive a compressor.

Topic 6a.—Why is jacketing of value? Is this true under all conditions? Is jacketing very effective? Derive the expressions for the heat removed by the jacket, the saving by the jacket and the water required for the jacket.

Topic 7.—What is multistaging? Sketch a figure and show why this is of value. What is the function of the intercooler? How large should it be? Derive the expression for two-stage compression:

$$\text{Work} = \frac{n}{n-1} p_1 V_1 \left[2 - \left(\frac{p'_2}{p_1}\right)^{\frac{n-1}{n}} - \left(\frac{p_2}{p'_2}\right)^{\frac{n-1}{n}} \right]$$

Topic 8.—Using expression of Topic 7, show that the work is a minimum when

$$p'_2 = \sqrt{p_1 p_2}$$

What are the conditions for minimum work for a three-stage compressor? Reduce the expression for work to a simple form. To what does the expression reduce for an m -stage compressor?

Topic 9.—Derive the formula for the temperature at the end of compression on the line $pV^n = \text{const.}$ when p_1 , p_2 , and T_1 are known. What is the value of the intermediate temperatures on a multistage compressor? Show that these are the same on each stage.

Topic 10.—Derive the formula for the heat removed by the intercooler and that for the amount of water required? What is the effect of leakage in multistage compression?

Topic 11.—Explain method of finding displacement of the various cylinders of a multistage compressor to deliver a given amount of air.

Topic 12.—Derive formulæ for the moisture removed from the intercooler and for the condition of the air discharged from it. How are the inlet and outlet pipes and valves designed?

Topic 13.—Derive a formula for the saving due to multistaging. Derive the expression for the unavoidable loss due to two-stage compression.

Topic 14.—Derive a formula for the work done in a single-stage engine. What is the temperature at the end of expansion? To what does the expression for work reduce for a two-stage engine?

Topic 15.—Derive an expression for the loss due to cooling after compression.

Topic 16.—Derive a formula for the loss due to a difference in the lines of expansion in the engine and of compression in the compressor.

Topic 17.—Derive the formula for the loss of pressure in a pipe line carrying air. Why is T assumed constant? What is the effect of leakage? How is the amount of leakage determined?

Topic 18.—Derive the expression for the loss due to throttling and one for the gain from preheating.

Topic 19.—Derive the expressions for the displacement of an air engine with complete expansion and compression and with incomplete expansion and compression to give a certain power.

Topic 20.—Derive the expression for the work of a fan blower. Explain how the quantity of air from a constant-speed compressor is regulated.

Topic 21.—Explain by means of a diagram the various losses which enter into an air-transmission system. Give the efficiency in terms of the ratio of two areas.

Topic 22.—Explain the use of logarithmic diagrams in plotting curves of the form $pV^n = \text{const.}$ Explain the method of increasing the range of a diagram.

Topic 23.—Sketch the forms of some of the air motors in common use and explain their action.

PROBLEMS

Problem 1.—Find the power to compress 1000 cu. ft. of free air per minute from 14.5 lbs. absolute to 60 lbs. gauge in a single-stage air compressor; $n = 1.35$, leakage = 3 per cent., clearance = 2 per cent.

Problem 2.—Find the power to compress 1000 cu. ft. of free air per minute from -0.3 lbs. gauge pressure to 160 lbs. gauge pressure in a two-stage air compressor with $n = 1.35$, leakage 3 per cent. in each cylinder, clearance 3 per cent. Find the intermediate pressure.

Problem 3.—Find the size of the compressors in Problems 1 and 2 if they operate at 120 r.p.m. and are double-acting.

Problem 4.—Find the temperature at the end of compression in Problems 1 and 2 if the original temperature were 75°F.

Problem 5.—Find the heat removed in the intercooler for compressor of Problem 2. Find the amount of water required if the water available is at 60°F. and is arranged by counter current to leave at 80°F. Find ΔT assuming that the value of the coefficient of heat transmission is constant. Find the value of K by assuming the velocity of the air to be 30 ft. per second and the velocity of the water as 10 ft. per second and using Nicolson's formula.

Problem 6.—Using the variable parts of the expression for work find the relative work for single, two-stage and three-stage compression between 14.5 lbs. and 290 lbs. absolute. Find the clearance factor for these assuming 3 per cent. clearance in each cylinder. Find the temperature at the end of compression in each case assuming 75° F. as the original temperature.

Problem 7.—Find the size air main to deliver 3000 cu. ft. of free air per minute when compressed to 145 lbs. absolute, if the temperature is 75° F. and the drop in pressure allowable is 2 lbs. in 160 ft.

Problem 8.—Find the efficiency of transmission if 1000 cu. ft. of free air per minute is compressed to 190 lbs. gauge pressure, transmitted 800 ft. in a tight main and used after storage in engines at 150 lbs. pressure in a single-stage engine. Assume all constants needed. Is the result the probable efficiency or the maximum efficiency?

Problem 9.—Find the various losses in the system described in Problem 8.

Problem 10.—Three $\frac{3}{4}$ -in. holes are in a pipe line carrying 1500 cu. ft. of free air per minute compressed to 125 lbs. gauge pressure and at 80° F. What is the percentage loss due to these holes?

Problem 11.—The wet bulb reads 70° F. in 80° F. weather when the barometer stands at 29.85 in. This air is compressed to 50 lbs. gauge pressure in the intercooler at 80° F. Has any moisture been precipitated? If not what is the relative humidity of the air? If precipitation occurs how much precipitation occurs per minute if 1000 cu. ft. of free air are handled per minute?

Problem 12.—Find the size of an air engine to develop 15 h.p. (a) with complete expansion and compression, and (b) with cut-off at 30 per cent., compression 20 per cent., clearance 5 per cent. $p_1 = 125$ lbs. absolute, $p_b = 14.8$ lbs. absolute. R.p.m. = 125.

Problem 13.—Air at 1500 lbs. absolute pressure is stored in a tank and when used in an engine it is throttled to 150 lbs. absolute pressure. The temperature in the tank is 80° F. What is the temperature at the end of complete expansion in the engine to 15 lbs. absolute pressure? How much of the energy in the tank is available in the engine after throttling?

Problem 14.—In Problem 13 the air on leaving the throttle valve is heated by a vapor lamp to 450° F. By what per cent. is the power of the engine increased by this? What is the temperature of discharge from the engine?

Problem 15.—An air compressor of Problem 1 has the compression line reduced to $pV^{1.35} = \text{constant}$ by the jacket. How much heat does the jacket remove? How much water does this require if the water range is from 70° F. to 90° F.?

Problem 16.—One thousand cubic feet of free air per minute is compressed from 15 lbs. pressure to 150 lbs. pressure (absolute) on two stages. The original temperature was 60° F. Find the final temperature of discharge. Find the percentage loss if this air is allowed to cool to 60° F. before it is used in the air motors; $n = 1.35$.

Problem 17.—How much loss occurs in Problem 15 due to the fact that the expansion in the engine is on the line $pV^k = \text{const.}$ instead of $pV^{1.35} = \text{const.}$? Express this as a percentage.

Problem 18.—Find the values of p and v at several points on the line, $pV^{1.25} = \text{const.}$, passing through the point $p = 165$ lbs. $V = 3$ cu. ft. by means of a logarithmic diagram. Use pressures of 150, 100, 50 and 25 lbs.

CHAPTER V

THE STEAM ENGINE

On account of the numerous improvements made upon it during the two centuries of its use, the **steam engine** was, until quite recently, the most important heat engine using steam. The **steam turbine** has taken this place at present due to the decreased cost of production, the greater concentration of power, and the good efficiencies over a wider range of load.

The engine was developed without any theory of thermodynamics by Worcester, Papin, Savery, Newcomen and Watt, and to account for the action of the engine in later times, Rankine in England and Clausius in Germany developed a mathematical theory of heat. The later development of the engine is connected with the names of Corliss, Porter, Reynolds, Willans, Sultzer and Stumpf. The engine has been improved by increasing the Carnot efficiency through the use of higher initial pressures and superheat and by lowering the back pressure, while the use of jackets, reheaters, superheated steam, four valves, heavy lagging, multiple staging and flow in one direction have all had their effects on its practical efficiency.

In the steam engine (Fig. 67) steam containing heat is admitted to the **cylinder A** by the **valve B**, so that it moves the piston. The **valve B** is operated by the **valve rod C** from an **eccentric** or **crank D** so that when the **piston E** has reached a certain point steam is **cut off** from the cylinder and the steam is allowed to **expand** to a point near or at the end of the stroke (**release point**) when the valve is so moved as to allow the steam to escape to the outside. The steam **admitted** to the other end or the inertia of the fly wheel causes the piston to **return** in its stroke forcing the steam out of the cylinder until a point near the end of the stroke (**point of compression**) is reached when the **exhaust** is closed and the movement of the piston **compresses** the steam until the valve again connects this side of the cylinder to the **steam chest F** and **steam pipe G** so that steam enters once more. In theory the **indicator card**

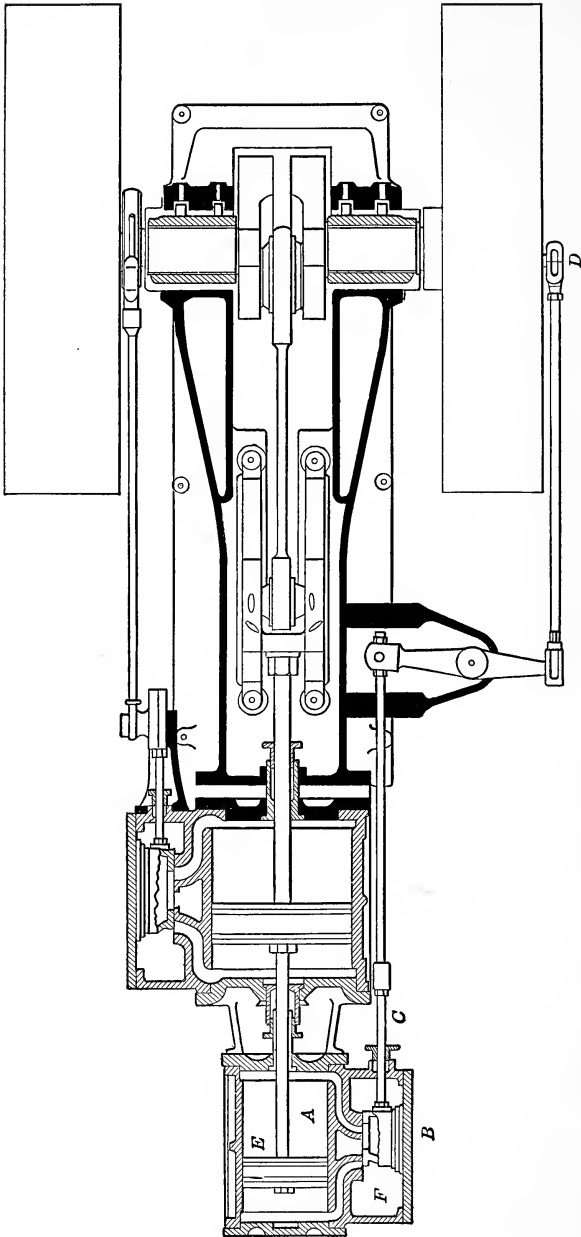

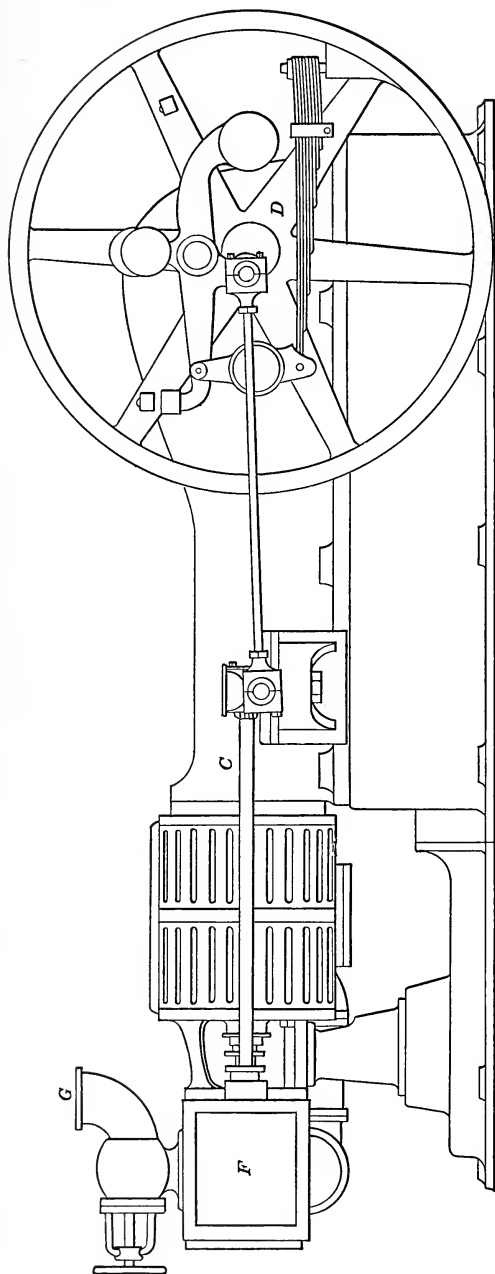

Fig. 67.—Steam engine (Compound).

will appear as in Fig. 68: The expansion and compression are **complete**. The point of **cut-off** is at 1, **release** at 2, **compression** at 3 and **admission** at 4. The quality of the steam at 3 is the same as that at 2, hence the condition at 4 is the same as that at 1 if the lines 1-2 and 3-4 are assumed to be adiabatics. 3-4 is the **compression** line of the steam in the **clearance space** 4-5. If these are adiabatics with M_0 pounds of steam on 3-4 and $M + M_0$ pounds of steam on 1-2, Fig. 69, with no clearance space and with the weight of steam M on the line 1-2 between the same pressures and qualities at the limiting points will have the same area and represent the cycle with no clearance. This is true because in theory the **clearance steam** ex-

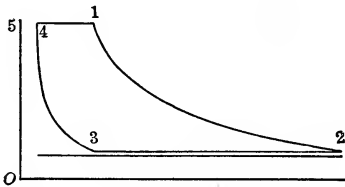

FIG. 68.—Indicator card from engine with complete expansion and complete compression.

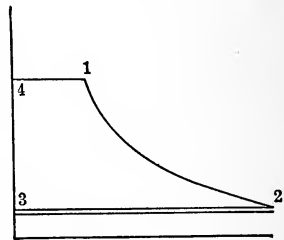

FIG. 69.—Indicator card with no clearance.

pands and contracts along the same line requiring and giving no work. M_0 is called the **clearance steam** and M is called the **working steam**, steam supply or boiler steam.

CYCLE OF STEAM ENGINE

Fig. 69 then represents the theoretical form of cycle used on the steam engine. It is known as the **Rankine** or **Clausius cycle** although the former name is employed at times for the cycle shown in Fig. 71. The difference between the **Carnot cycle** and the **Rankine cycle** is that in the former cycle the working substance is supposed to be in the cylinder and heat only is added, while in the latter substance is added and with it heat. On the Carnot cycle, if represented by Fig. 68, the quality changes from that at 4 to that at 1, growing greater, while it decreases from 2 to 3, hence 1-2 and 4-3 are not similar adiabatics. For the Rankine cycle the quality on 4-1 is constant, the variable being the mass and this is true on 2-3. In both

cases 4-1 and 2-3 are isothermals if saturated steam is used. The heat added on the Carnot cycle is $Mrdx$ and on the other is $xrdm$, the total amount being the same in each.

In Fig. 69 the exhaust steam could be used to heat an equal weight of water to the temperature of exhaust for boiler feed, since this could be done by the heat of the liquid of the steam even if the water supply were at 32° F. With the heat of vaporization in addition for the vapor part of the mixture, this and even more could be done. This additional amount is of no value for the operation of the engine although for warming other water it has a great value. The point which must be grasped by the student is the fact that the heat in the exhaust could, if properly used, heat the feed necessary for the working steam to a temperature of the exhaust pressure. For this reason, the **datum plane** from which heat is to be measured is always taken as at the temperature of the exhaust.

HEAT AND EFFICIENCY OF CYCLE

The heats added on the different lines are:

$$M(i_1 - q'_o) \text{ on } 4-1 \quad (1)$$

$$0 \text{ on } 1-2$$

$$M(i_2 - q'_o) \text{ on } 2-3 \quad (2)$$

$$0 \text{ on } 3-4, \text{ since } M = 0$$

(Note.— q'_o is used rather than q'_2 because 0 is used to refer to the datum in all cases.)

$$\therefore AW = Q_1 - Q_2 = M[(i_1 - q'_o) - (i_2 - q'_o)] = M(i_1 - i_2) \quad (3)$$

It is to be remembered that i_1 and i_2 are the heat contents at two points on the same adiabatic and hence they are found in the same entropy column or line.

$$Q_1 = M[i_1 - q'_o]$$

$$\text{Theoretical eff.} = \eta_3 = \frac{i_1 - i_2}{i_1 - q'_o} \quad (5)$$

This is sometimes called the Rankine efficiency.

In some texts the work of pumping the water into the boiler from 4 to 1 is considered giving net work

$$i_1 - i_2 - A(p_1 - p_2)v'$$

The last term is small. It really does not belong to the engine being one of the charges against the boiler.

$$\text{Now, the Carnot eff.} = \eta_1 = \frac{T_1 - T_o}{T_1}$$

$$\eta_2 = \frac{\eta_3}{\eta_1}$$

If M pounds of steam are required per horse-power hour, the work = 2546 B.t.u. and the heat is $M(i_1 - q'_o)$.

$$\eta_5 = \frac{2546}{M(i_1 - q'_o)} \quad (6)$$

$$\eta_1 = \frac{\eta_5}{\eta_3}$$

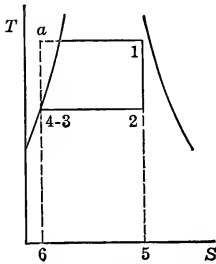

FIG. 70.— T - S diagram of Rankine cycle.

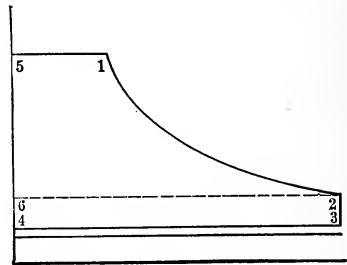

FIG. 71.—Rankine cycle with incomplete expansion.

The **T-S diagram** for this is an aid in studying the cycle. It is shown in Fig. 70. In this, points 3 and 4 come together. The heat added per pound from 3 to 1 is

$$6-4-3-1-5 = i_1 - q'_o$$

$$\text{Heat } 12 = 0$$

$$\text{Heat } 23 = 6-3-2-5 = i_2 - q'_o$$

$$\text{Work} = 64315 - 6325 = 3412 = i_1 - i_2$$

4-a-1-2 would show the Carnot cycle.

If the expansion is not carried to the back pressure line it is called **incomplete expansion** and the cycle using such is then sometimes spoken of as the **Rankine cycle**. The best way to study this cycle is by dividing it into two parts by the line 2-6, Fig. 71.

$$\text{Area } 5126 = M(i_1 - i_2)$$

$$\text{Area } 2346 = M[A(p_2 - p_3)v_2]$$

$$AW = 451234 = M[(i_1 - i_2) + A(p_2 - p_3)v_2] \quad (7)$$

$$\eta_3 = \frac{i_1 - i_2 + A(p_2 - p_3)v_2}{i_1 - q'_o} \quad (8)$$

$$\eta_1 = \frac{T_1 - T_o}{T_1}$$

$$\eta_2 = \frac{\eta_3}{\eta_1}$$

$$\eta_5 = \frac{2546}{M(i_1 - q'_o)}$$

$$\eta_4 = \frac{\eta_5}{\eta_3}$$

η_3 for the engine cycle is sometimes called the **Rankine efficiency** of the cycle or this term is applied to equation (5).

In the above equations, i_1 and i_2 are heat contents on the same adiabatic, hence, if the entropy is known for point 1, i_2 is found at pressure 2 in same entropy column as i_1 if there is a table or on the same entropy line from a chart. If there is neither table nor chart which can be used, the formula for the adiabatic is to be used to find the quality at 2 and from this, i_2 .

$$V_1 = Mx_1v''_1 \quad (\text{To find } x_1).$$

$$s'_1 + \frac{x_1r_1}{T_1} = s'_2 + \frac{x_2r_2}{T_2} \quad (\text{To find } x_2)$$

$$V_2 = Mx_2v''_2 \quad (\text{To find } V_2).$$

$$i_1 = q'_1 + x_1r_1 \quad (\text{To find } i_1).$$

$$i_2 = q'_2 + x_2r_2 \quad (\text{To find } i_2).$$

All necessary terms are known for any of these formulæ if taken in the order given. The value of x_1 being theoretical and therefore the highest possible, is that of the boiler steam and should be so used.

STEAM CONSUMPTION

From equations (3) and (7) the **amount of steam per horse-power hour** theoretically required is given by

$$M = \frac{2546}{i_1 - i_2} \quad (9)$$

$$M = \frac{2546}{i_1 - i_2 + A(p_2 - p_3)v''_2} \quad (10)$$

To illustrate the applications of the formulæ, suppose an engine uses 26 lbs. of steam per horse-power hour at 110 lbs. gauge pressure with $x = 0.98$ and has a pressure at the end of expansion of 15 lbs. gauge and a back pressure of 0.5 lbs. gauge. It is desired to find the various efficiencies.

From Peabody's Temperature Entropy Tables	From Marks and Davis' Charts
$p_1 = 110 + 14.7 = 124.7$	$p_1 = 124.7$
$t_1 = 344.2$	$s_1 = 1.563$
$s_1 = 1.563$	$i_1 = 1173$
$i_1 = 1172.5$	$p'_2 = 29.7$
$p_2 = 15 + 14.7 = 29.7$	$s_2 = 1.563$
$s_2 = 1.563$	$i_2 = 1065$
$i_2 = 1065.8$	$x_2 = 0.897$
$v_2 = 12.55$	$v_2 = 12.5$
q'_o of $(0.5 + 14.7)$ lbs. = 181.9	
$t_o = 213.7$	

By computation the following results, using the tables of Marks and Davis:

$$\begin{aligned}
 p_1 &= 129.7 \\
 i_2 &= 318.4 + 0.98 \times 872.7 = 1173.4 \\
 s_1 &= 0.4996 + 0.98 \times 1.0820 = 1.56 \\
 p_2 &= 29.7 \\
 s_2 &= 1.56 = 0.3673 + x \times 1.3326 \\
 x_2 &= \frac{1.1927}{1.3326} = 0.895 \\
 i_2 &= 218.2 + 0.895 \times 945.6 = 1065 \\
 v_2 &= 0.895 \times 13.89 = 12.42 \\
 q'_o &= q' \text{ of } (14.7 + 0.5) = 181.6
 \end{aligned}$$

Any of the three sets of values could be used. Using the first

$$\begin{aligned}
 \eta_1 &= \frac{344.2 - 213.7}{344.2 + 459.6} = \frac{130.5}{803.8} = 16.2 \text{ per cent.} \\
 \eta_3 &= \frac{1172.5 - 1065.8 + \frac{1}{778}(29.7 - 15.2) 144 \times 12.55}{1172.5 - 181.9} \\
 &= \frac{139.9}{990.6} = 14.2 \text{ per cent.} \\
 \eta_2 &= \frac{14.2}{16.2} = 87.2 \text{ per cent.} \\
 \eta_5 &= \frac{2546}{26(1172.5 - 181.9)} = \frac{2546}{2580} = 9.9 \text{ per cent.} \\
 \eta_4 &= \frac{9.9}{14.2} = 70 \text{ per cent.}
 \end{aligned}$$

The results of the above computations show that the efficiency of the theoretical cycle is more than 87 per cent. of that of the most perfect cycle but that the actual engine only utilizes 70 per cent. of the amount which should be available theoretically. For these reasons there is not much chance of improving the cycle of the steam engine but to make η_4 , the practical efficiency, greater the cylinder is covered with some non-conducting material, a steam jacket is used or superheated steam may be employed. These all tend to cut down the transfer of heat to and from the cylinder walls and thus cut down the amount of steam required.

TEMPERATURE—ENTROPY DIAGRAMS

The cycle is shown on the T-s diagram, Fig. 72. The free expansion from 2 to 3 cuts off the corner of the figure as shown by 2-3. This figure and Fig. 70 are used to represent

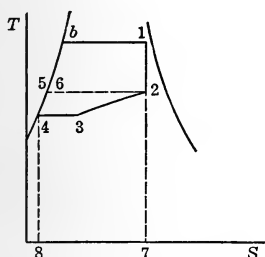

FIG. 72.—T-S diagram of Rankine cycle with incomplete expansion.

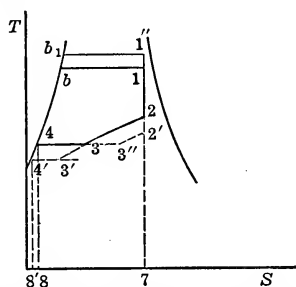

FIG. 73.—Effect of increasing temperature range.

the Rankine cycle without and with complete expansion. They are not true representations since the lines of Figs. 70 and 72 represent additions of heat and not of substance as is the case on the actual cycle. Because the heat added in the figures on the various lines represents the heat added on the lines with the substance the figures are used to represent this cycle. Moreover, the area of the figure 1234 of Fig. 70 or 12345b of Fig. 72 represents the difference between Q_1 and Q_2 and hence represents the work.

The efficiency is represented by the area of the cycle divided by the total area beneath 4-1 in Fig. 70 or 72 and hence, if the temperature is increased, both of these areas become greater and the efficiency is increased. This is shown by b_1-1'' of Fig. 73.

$$\text{Eff.} = \frac{4b_11''234}{84b_11''7} > \frac{4b1234}{84b17}$$

If, now, the lower temperature is lowered from 3 to 3', the denominator of the fraction is changed a slight amount, 8'4'48, while the numerator is changed by the area 433'4'. In this way the efficiency is increased in most cases. If the free expansion is so great, as shown in Fig. 73, that the distance 3-4 is small, it may be that the added area, 433'4', may not be greater than 8'4'48 and the efficiency is not increased by lowering the **back pressure**. As the free expansion 2-3 becomes less, as 2'-3'' (which means that the expansion 1-2 is more nearly complete), the line 3''-4 is so long that the gain in efficiency due to a decrease in back pressure is great. The **increase in pressure** to give a perceptible increase in temperature for the boiler steam is so great that the

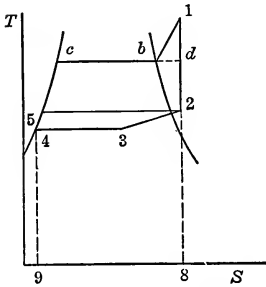

FIG. 74.— T - S diagram of Rankine cycle with superheated steam.

pressure must be increased considerably to raise the line $b-1$ an appreciable amount. Hence the gain in efficiency from an increase of pressure is not as marked as a slight decrease in the lower pressure of the cycle when the temperature change is more rapid. Thus, to decrease the back pressure from 15 lbs. to 2 lbs. abs. means a change of 87° F. while an increase from 100 lbs. to 113 lbs. means an increase of 10° F., from 150 lbs. to 163 lbs., 8° F., while from 200 lbs. to 213 lbs. means an increase of less than 6° F. It must also be remembered that a decrease in the back pressure with much free expansion does not necessarily give an increase of efficiency.

In order to increase the efficiency by increasing the upper temperature without an increase in pressure **superheated steam** is used. Theoretically it will be seen that although this does increase the efficiency there is not much gain because this heat is not added at constant temperature. Fig. 74 illustrates this case

$$Q_1 = 9cb18 = q'_1 - q'_o + r + \int c_p dt = i_1 - q'_o$$

$$Q_2 = 94328 = i_2 - q'_o - A(p_2 - p_3)v_2$$

$$Q_1 - Q_2 = \text{work} = 45cb1234$$

Now the triangle $1-d-b$ is the part of the figure which represents the increase due to superheat and being added to $5cb d 234$

as well as to $9\ c b d\ 8$ it increases the efficiency, having the greater effect on the small numerator. This reasoning is made evident by observing that the efficiency $\frac{5\ c b d\ 234}{95\ c b d\ 8}$ is about the same as the efficiency of the cycle of Fig. 71 with saturated steam and the same pressure ranges and the expression for the latter is made into that for Fig. 74 by adding $b-1-d$ to numerator and denominator.

EFFECTS OF CHANGES

These facts have been shown by the late Prof. H. W. Spangler in his Applied Thermodynamics. The curves of Figs. 75, 76 and 77 show how the theoretical efficiency is increased as the pressures and superheats are changed.

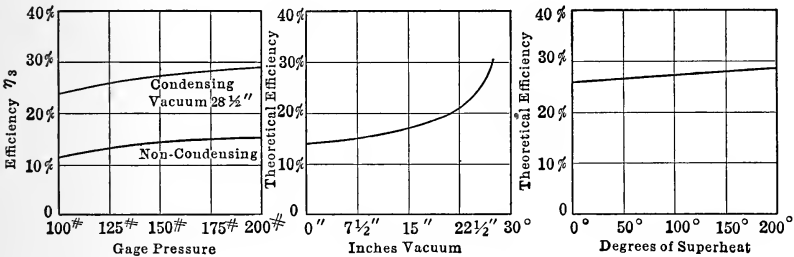

FIG. 75.

FIG. 76.

FIG. 77.

FIG. 75.—Effect of change of steam pressure on efficiency, complete expansion and saturated steam.

FIG. 76.—Effect of change of back pressure on efficiency (150 lb. steam 1° superheat), complete expansion.

FIG. 77.—Effect of change of superheat on efficiency (151 lb. steam to 28.5 in vac.), complete expansion.

These figures are all drawn for complete expansion and, although in all cases the effect of vacuum increase is greater than the effect of the same change in the initial pressure, the effect is not so marked as that shown in Fig. 76 when there is incomplete expansion. These figures are all drawn from theoretical considerations.

Although the **effect of superheat** is theoretically slight, its effect on the **actual efficiency** may be much more pronounced since it cuts down certain losses which occur in the cylinder and therefore its practical effect is very valuable.

TESTS OF ENGINES

To actually determine the steam consumption of an engine a test is made while the load is kept constant on the engine. If possible the exhaust steam is condensed in a **surface condenser** and weighed at regular intervals and at the same time **indicator cards** are taken and readings are made on the scales of the **Prony brake**, or **watt meter** if the engine is used to drive a generator, on the **calorimeter** to determine the **quality of the steam**, on the **pressure gauge** and **barometer**, on the **temperature and pressure** of the exhaust steam, on the temperature of the **condensate** and on the **revolution counter**. From this data, as will be shown, the **steam per horse-power hour**, the **pressure and quality of the steam supply**, and the **pressure of the exhaust** may be found to be used for the actual thermal efficiency.

CALORIMETERS

The **calorimeter** used to determine the quality of the steam may be of three forms: the **electric**, the **separating** and the **throttling calorimeters**. The latter is shown in Fig. 78. The form here shown is the **Barrus Universal Throttling Calorimeter**, so called because by the addition of the **drip pot C** it may care for steam of any moisture content. In this a **sample of steam** is taken preferably from a vertical steam pipe **A**. In horizontal pipes it has been found that much of the moisture separates out and flows along the bottom of the pipe so that a fair sample cannot be obtained. The **sampling tube B** is a pipe closed at the end and containing a number of small holes around its circumference and along its length to take steam from various parts of the pipe. This steam is carried into the **drip pot C**, which is in reality a **separator**, where most of the moisture is taken from the steam. The height of the water in the drip pot is shown by the **glass gauge D** and the pressure is shown by the **gauge E**. Steam then passes over through a pipe and around a **thermometer well** containing the **upper thermometer F** and from here it passes through a small hole in the **throttle plate G** to the thermometer well containing the **lower thermometer H** and from here to the atmosphere. The **mercury gauge I** shows the pressure around the lower thermometer well. The throttle plate is held between flanges but insulated from them by some non-conducting material.

To find the **amount of water** collected in the **drip pot** a string is tied around the glass gauge and when the water reaches that level the time is noted. The water in the drip pot is drawn off at any convenient time into a cup of **cold water** *J* so that the water level falls below the string. This is done by opening the **valve** *K* and putting the end of the drip pipe beneath the water level in the cup so that none of the hot water from the drip pot

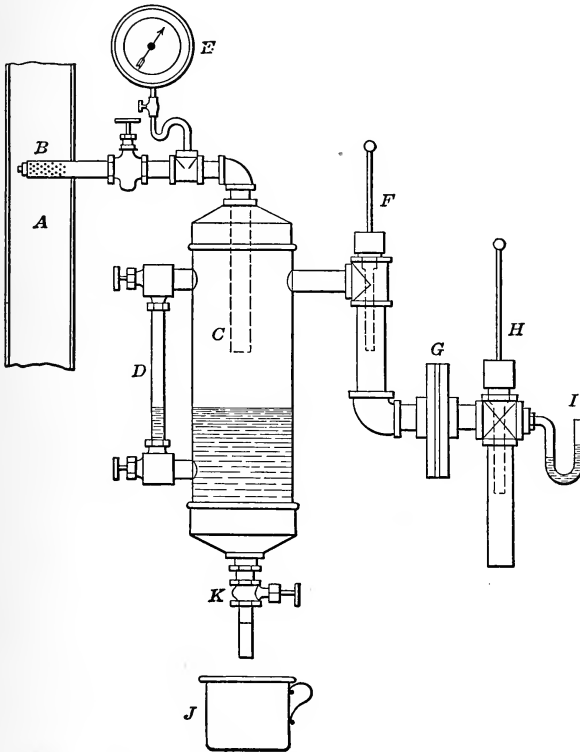

FIG. 78.—Barrus universal calorimeter.

can evaporate on reaching a place of atmospheric pressure. The cup is lowered after closing *K* and after catching all the drip its change of weight will give the weight of water drawn off. The time at which the water again reaches the level of the string is noted and the interval between the two times of passing the mark will give the time taken for this water to be caught. This is reduced to pounds per minute or second. Call this *m* pounds.

To find the weight of steam passed through the throttle hole in the same interval of time, this steam is exhausted into water and condensed or, what is quite customary, the hole is measured and Napier's formula

$$M = \frac{pF}{70}$$

is used.

If the separator were perfect the quality of the steam coming from the pipe would be,

$$x = \frac{M}{M + m}, \quad (11)$$

since M is the weight of dry steam in $M + m$ pounds of mixture. This drip pot, if perfect, would be a form of **separating calorimeter**. This is not a perfect separator and so the quality of the steam leaving is determined by throttling the steam.

The steam is throttled from the pressure shown by E to that shown by I . **Throttling action** means constant heat content. On expanding steam which is practically dry, it becomes superheated.

$$i_e = i_i$$

$$q'_e + x_e r_e = q'_i + r_i + \int c_p dt = i_i \quad (12)$$

$$x_e = \frac{i_i - q'_e}{r_e} \quad (13)$$

The thermometer H gives the number of degrees superheat when the saturation temperature corresponding to the pressure at I is found. Since the thermometer may register incorrectly due to the fact that the mercury column projects beyond the top of the thermometer well, the thermometer F is used to check this and determine the error. The thermometer wells are filled with heavy oil or with mercury and the thermometers are interchanged after each reading so as to equalize errors in the thermometers. After this is done the temperature of saturation at the average pressure shown by E is found and the difference between this and the average reading of F is the error due to stem exposure. An error proportional to the amount of exposed mercury column is assumed and the average reading of H is corrected. From this the degrees of superheat are found, then

i ; and, after this, x_e is found from equation (13). The weight of dry steam is then

$$xM$$

and the actual x is
$$X = \frac{xM}{M + m} \quad (14)$$

Part of this X is due to radiation from the instrument and to find this correction the instrument is operated with steam slightly superheated or dry steam and the apparent quality, x_{dry} , is found.

$$1 - x_{dry}$$

is the correction to be applied for this instrumental condensation. A common way to run this **dry test**, as it is called, is to attach the calorimeter to a boiler with banked fires and a shut stop valve in which case the steam in the steam space is dry.

Thermometers are sometimes calibrated to read correctly when immersed to a certain depth and if such are used there is no need for the upper thermometer. Such thermometers are called **constant immersion thermometers**.

Suppose the averages of a number of readings taken at five-minute intervals are as given below and the quality is desired.

p_1	=	112-lb. gauge
p_2	=	2 in. Hg.
Error in gauge	=	+ 2 lbs.
Barometer	=	29.8 in.
T_1	=	335.20° F.
T_2	=	265.2° F.
Wt. of drip	=	0.2 lbs. per 10 min.
Area of hole	=	0.01 sq. in.
Exposed column	=	120° F. for T_1 .
	=	100° F. for T_2 .
Observed p_1	=	112 lbs.
Error	=	<u>2</u>
Corrected p_1	=	110 lbs.
Barometer	=	<u>14.64</u>
Absolute p_1	=	114.64
T_1 sat.	=	337.92° F.
T_1 observed	=	<u>335.2° F.</u>
Error T_1	=	2.72° F.

Error $T_2 = 2.72 \times \frac{100}{120}$	=	2.27° F.
Observed T_2	=	$\frac{265.2^\circ \text{ F.}}{\quad}$
Corrected T_2	=	267.47° F.
Observed $p_2 = 2 \text{ in. Hg.}$	=	0.98 lbs.
Barometer	=	$\frac{14.64}{\quad}$
Absolute p_2	=	15.62 lbs.
Temp. sat.	=	215.07° F.
Corrected T_2	=	267.47° F.
Degrees of superheat	=	52.40° F.

i for 15.62 lbs. and 52.40° F. superheat = 1177 B.t.u (from Marks & Davis)

q' for 114.64 lbs.	=	308.7
r for 114.64 lbs.	=	880
$308.7 + 880 x$	=	1177

$$x = \frac{868.3}{880} = 0.986$$

$$m = 0.2 \text{ lbs. in } 10 \text{ min.}$$

$$M = \frac{114.64 \times 0.01}{70} \times 60 \times 10 = 9.83$$

$$X = \frac{0.986 \times 9.83}{9.83 + 0.2} = 0.968$$

The **object of the drip pot** is to care for any large amount of moisture for, if the amount of moisture is over 4 per cent., the equation

$$q' + xr = i_i$$

would give an i_i so small that the steam could not be superheated and, of course, the moisture in the low-pressure steam could not be known. Hence the upper x could not be found. The maximum amount of moisture possible with steam superheated on the lower side of the orifice depends on the pressure but 4 per cent. is the usual amount for pressures used in practice. Wherever the thermometer I shows 212° F. the drip pot is needed as there is too much moisture present.

The **electric calorimeter** uses an electric current to dry the steam and by calibrating the same the amount of power for each per cent. of moisture at a given pressure can be found and from this the quality for the actual power is determined.

A condenser is not always applicable for the determination of the weight of steam supplied to an engine and in that case the engine is supplied from a boiler or group of boilers which have been **blanked off** from the others. In this way the weight of boiler feed gives the steam supplied to the engine if the weight of water left in the boiler at all times is constant. This condition is approximated by keeping the level of the water in the boiler gauge constant but even in such a case the change of temperature or of the rapidity of firing may make this an uncertain guide. To eliminate the effect of this uncertainty such tests should extend over a considerable time, say 4 to 6 hours and in some cases 24 hours. If a condenser is used a test of an hour or less is sufficient for accurate results after the engine is brought to a uniform condition.

ANALYSES OF TESTS

To study the action of the cylinder walls two methods of analyzing these test results will be examined, one analytical, the other graphical.

Hirn's Analysis.—Hirn's analysis of the cylinder performance of steam engines consists in operating a test for a certain length of time and from the observations computing the actual performance of the engine. To better illustrate this analysis a case will be computed. From the test the following average results are found:

Time of test.....	60 min.
Size of engine.....	10 × 15
Clearance.....	10 per cent.
No. of revolutions during test.....	14,400
Pounds of steam used.....	2356
Average weight of steam per card, $\frac{2356}{2 \times 14400}$ =	0.0816 lbs.
Average pressure at throttle.....	105 lbs.
Barometric pressure.....	14.5 lbs.
Average of quality of steam.....	0.99
Average temperature of condensate.....	120° F.
Average temperature of water leaving condenser.....	105° F.
Average temperature of water entering condenser.....	85° F.
Weight of condensing water used.....	94,240 lbs.
Weight of water per pound of steam.....	40 lbs.

Average results from indicator cards

Point of admission at 1.....	0.0 per cent.
Point of cut-off at 2.....	25 per cent.
Point of release at 3.....	90 per cent.
Point of compression at 4.....	22 per cent.
Abs. pressure at 1.....	48 lbs. per sq. in.
Abs. pressure at 2.....	107 lbs. per sq. in.
Abs. pressure at 3.....	37 lbs. per sq. in.
Abs. pressure at 4.....	16 lbs. per sq. in.
Work area during admission, $Wa = 5-1-2-6$	2.83 sq. in.
Work area during expansion, $Wb = 6-2-3-7$	3.91 sq. in.
Work area during exhaust, $Wc = (3-10-8-7) -$ (9-4-10-8).....	-0.98 sq. in.
Work area during compression, $Wd = 5-1-4-9$...	-0.52 sq. in.

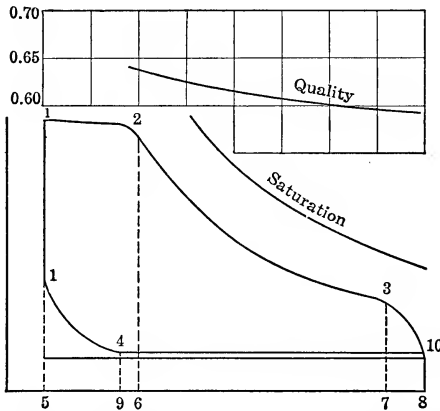

FIG. 79.—Average indicator card from test for Hirn's analysis.

The results above have all been averaged from the various readings and cards. The head end and crank end have been averaged together although at times they are worked up separately the weight of steam being divided between the two ends in proportion to the total volume at the point of cut-off although there is no true foundation for this method. Another method of division may be used as shown by Clayton. See page 210.

The first point to compute in Hirn's analysis is the weight of **clearance steam** per card, M_o . At the point 4 steam is assumed to be dry. This has been indicated by experiments as far as they have been tried although these experiments were difficult

to perform and are not so reliable as would be desired. With this assumption

$$V_4 = M_o v''_4$$

$$\text{or } M_o = \frac{V_4}{v''_4} \quad (15)$$

$$V_4 = \text{total volume at 4}$$

$$v''_4 = \text{specific volume of dry steam at 4}$$

v''_4 is found from the steam tables. After this the weight of the **working steam** per card is found.

$$M = \frac{\text{weight}}{2 \times \text{No. of revolutions}} \quad (16)$$

Knowing M and M_o the quality of the steam at the various events of the cycle may be found if the pressures and volumes at these points are known from the cards.

$$x_1 = \frac{V_1}{M_o v''_1} \quad (17)$$

$$x_2 = \frac{V_2}{(M + M_o) v''_2} \quad (18)$$

$$x_3 = \frac{V_3}{(M + M_o) v''_3} \quad (19)$$

From the pressures the values of the heat of the liquid and the internal heat of vaporization may be found and from these the **intrinsic energy** at all points may be computed.

$$A U_1 = M_o (q'_1 + x_1 \rho_1) \quad (20)$$

$$A U_2 = (M + M_o) (q'_2 + x_2 \rho_2) \quad (21)$$

$$A U_3 = (M + M_o) (q'_3 + x_3 \rho_3) \quad (22)$$

$$A U_4 = M_o (q'_4 + \rho_4) \quad (23)$$

From the indicator cards the **external works** during the various periods may be found.

$$\text{Work of admission} = W_a = 5126 \quad (24)$$

$$\text{Work of expansion} = W_b = 6237 \quad (25)$$

$$\text{Work of exhaust} = W_c = -94108 + 73108 \quad (26)$$

$$\text{Work of compression} = W_d = -5149 \quad (27)$$

The **energy added** to the engine from the outside during admission is

$$Q_1 = M (q' + xr) \quad (28)$$

The energy removed is

$$Q_2 = -M[q'_o + G(q'_a - q'_i)] \quad (29)$$

G = weight of condensing water per pound of steam.

M = weight of steam per card.

q' , x , and r are for conditions of steam at the throttle valve.

q'_o = heat of liquid at temperature of condensed steam.

q'_a = heat of liquid at temperature of discharge condensing water.

q'_i = heat of liquid at temperature of inlet condensing water.

Now the heat added during any event is found by

$$Q = A[U_2 - U_1 + W] \quad (30)$$

If the heat coming from the cylinder walls during the different events is represented by Q_a , Q_b , Q_c or Q_d , using the equation above, the various quantities are given by the equations

$$Q_1 + Q_a = AU_2 - AU_1 + AW_a \quad (31)$$

$$Q_a = -Q_1 + AU_2 - AU_1 + AW_a \quad (32)$$

$$Q_b = AU_3 - AU_2 + AW_b \quad (33)$$

$$Q_c = -Q_2 + AU_4 - AU_3 + AW_c \quad (34)$$

$$Q_d = AU_1 - AU_4 + AW_d \quad (35)$$

If these result in **positive quantities** heat is given up by the walls while negative values mean that heat is given to the cylinder walls. If these are added together the net amount must be equal to the amount given or taken by the cylinder walls. If there is no source of heat in the cylinder walls they could not give heat so that the sum could not be positive. If negative this heat would finally melt the iron if abstracted for a considerable time. Since the walls do not change in temperature this negative sum must equal the heat radiated from the cylinder and

$$Q_a + Q_b + Q_c + Q_d = Q_r \quad (36)$$

A check equation for Q_r may be determined by blocking the engine, filling the cylinder with boiler steam and measuring the condensation. Then

$$Q_r = M_r(q' + xr - q'_o) \quad (37)$$

If there is a steam jacket there could be a positive sum as heat could then be given up by the walls from the heat in the jacket. In this case

$$Q_a + Q_b + Q_c + Q_d + Q_j = Q_r \quad (38)$$

and Q_j is determined by finding the weight of steam condensed in the jacket while the engine is running. M_j is the condensation due to the heat given to the steam within and

$$Q_j = M_j (q' + xr - q'_o) \quad (39)$$

Q_r must be determined while the engine is at rest by the condensation in the jacket.

This analysis will give the quantities Q_a , Q_b , Q_c and Q_d , but it will not give the value of any of them for a portion of an event. It will tell that so much heat has been given or received during an event but it will not indicate at what point this or any part of it has been given up. If the value of

$$V = (M + M_o)_{x1} v''_1 \quad (40)$$

be found at cut-off and for several other pressures the saturation curve may be drawn on Fig. 79. The ratio of the volume on the expansion line to that on this line for any pressure will give the quality x . This quality is sometimes plotted on the card as shown in Fig. 79.

These equations will now be applied to the test data. The engine is 10 in. in diameter and of 15-in. stroke. The volume swept out in one stroke is therefore 0.682 cu. ft. and if the card is 4 in. long and has been drawn with a 40-lb. spring the scale of area is

$$\text{area scale} = \frac{40 \times 144}{778} \times \frac{0.682}{4} = 1.260 \text{ B.t.u. per sq. in.}$$

If 10 per cent. of the card length be added to each event expressed in per cent. of the stroke to give the total percentage volume, these when multiplied by the displacement will give the total volume in cubic feet at each event. A table is then made for the events as shown below, using Peabody's tables.

Event	Actual volume	Pressure	Specific volume	q'	ρ'
1	0.068	48 lbs.	8.84	247.8	846.2
2	0.238	107 lbs.	4.16	303.5	801.5
3	0.682	37 lbs.	11.29	231.6	858.6
4	0.220	16 lbs.	24.74	184.6	893.8

$$M_0 = \frac{0.220}{24.74} = 0.0089 \text{ lbs.}$$

$$x_1 = \frac{0.068}{0.0089 \times 8.84} = 0.865$$

$$x_2 = \frac{0.238}{(0.0816 + 0.0089)4.16} = 0.633$$

$$x_3 = \frac{0.682}{0.0905 \times 11.29} = 0.668$$

$$U_1 = 0.0089 [247.8 + 0.865 \times 846.2] = 8.72$$

$$U_2 = 0.0905 [303.5 + 0.633 \times 801.5] = 73.50$$

$$U_3 = 0.0905 [231.6 + 0.668 \times 858.6] = 72.80$$

$$U_4 = 0.0089 [184.6 + 893.8] = 9.60$$

$$AW_a = 2.83 \times 1.260 = 3.57 \text{ B.t.u.}$$

$$AW_b = 3.91 \times 1.260 = 4.92 \text{ B.t.u.}$$

$$AW_c = -0.98 \times 1.260 = -1.23 \text{ B.t.u.}$$

$$AW_d = -0.52 \times 1.260 = -0.65 \text{ B.t.u.}$$

$$Q_1 = 0.0816 [312.0 + 0.99 \times 877.1] = 96.5 \text{ B.t.u.}$$

$$Q_2 = -0.0816 [88 + 40 (73.0 - 53.1)] = -72.0 \text{ B.t.u.}$$

$$Q_a = -96.5 + 73.5 - 8.72 + 3.57 = -28.15 \text{ B.t.u.}$$

$$Q_b = 72.80 - 73.5 + 4.92 = +4.22 \text{ B.t.u.}$$

$$Q_c = 72.0 + 9.60 - 72.8 - 1.23 = +7.57 \text{ B.t.u.}$$

$$Q_d = 8.72 - 9.60 - 0.65 = -1.53 \text{ B.t.u.}$$

$$Q_r = \text{-----} \\ -16.89 \text{ B.t.u.}$$

Total work.....	6.61 B.t.u.
Heat supplied above 32° F.....	96.5 B.t.u.
Heat supplied above temperature of exhaust.....	81.3 B.t.u.
Heat removed by walls during events:	
Admission.....	28.15 B.t.u.
Expansion.....	-4.22 B.t.u.
Exhaust.....	-7.57 B.t.u.
Compression.....	1.53 B.t.u.

TEMPERATURE ENTROPY ANALYSIS

The **graphical temperature entropy analysis** is to be used next and in this the same test is made but the only observations necessary are:

Size of engine..... 10 in. × 15 in.

Average pressure..... 119.5 lbs. per sq. in. abs.

Average quality..... 0.99

Weight of steam.....	2356 lbs.
Revolutions.....	14,400
Clearance.....	10 per cent.
Average compression.....	22 per cent.
Average indicator card.....	Fig. 81

This method has been developed by a number of persons. Prof. Boulvin's method has been combined with that of Reeves in reducing the method given below.

The average indicator card is constructed by averaging the pressures at ten or more equidistant points along the card or a

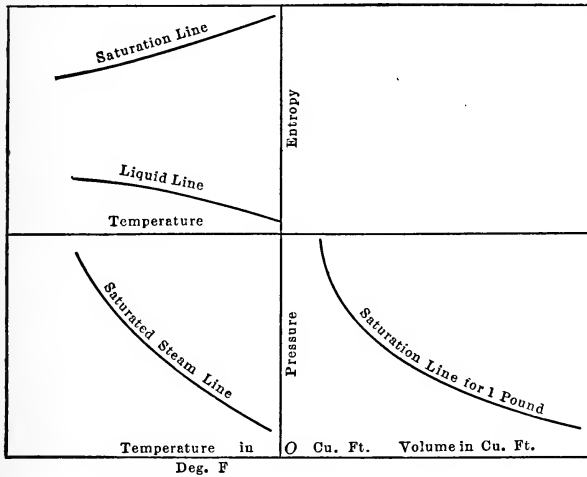

FIG. 80.—Temperature entropy diagram for analysis of engine performance.

card may be selected on which the m.e.p. is equal to the average m.e.p. of the test. M and M_0 are then found.

$$M_0 = \frac{V_4}{v''_4} = 0.0089 \text{ as before.}$$

$$M = \frac{Wt}{2 \times \text{rev.}} = 0.0816 \text{ lbs. as before.}$$

The chart for the **Temperature Entropy** analysis is now to be drawn. This consists of **four quadrants**, Fig. 80, a **p-v** quadrant having a line for 1 lb. of saturated steam, a **T-p** quadrant having the line of saturated steam, a **T-s** quadrant having the liquid line for 1 lb. of water and the saturation line for 1 lb. of steam

and a **V-s quadrant** which is used for transferring the values of x . This figure is constructed by aid of the steam tables and takes the form shown in Fig. 80.

To transfer the indicator card to this figure, a number of points on the mean diagram, Fig. 81, are taken and the heights from the line of absolute zero pressure and lengths from absolute zero of volume are measured and tabulated. The lengths are then multiplied by the scale of volume of Fig. 81 and divided by the product of the scale of Fig. 80 and the value of $M + M_o$, in order to get the distance to each point if 1 lb. of steam were present on the expansion line. The heights are multiplied by the scale of 81 and divided by the scale of 80. Thus, in the

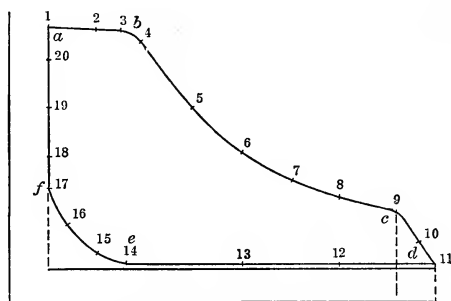

FIG. 81.—Average indicator card from test arranged for T - S analysis.

problem considered there is a 4-in. card for a 10×15 engine with a 40-lb. spring and

$$M + M_o = 0.0816 + 0.0089 = 0.0905$$

Fig. 80 has scales of 2.5 cu. ft. to the inch and 20 lbs. per square inch to the inch. The cylinder has a displacement of 0.682 cu. ft. with a 4-in. card. The lengths are therefore multiplied by

$$\frac{0.682}{4} \times \frac{1}{0.0905} \times \frac{1}{2.5} = 0.754$$

in order to get the length to lay off in Fig. 80 so as to represent the card for 1 lb. of steam on the expansion line. The multiplier for height is merely $40/20 = 2.00$. These distances are tabulated to aid in the work as shown.

Points	Original card		Analysis card		Points	Original card		Analysis card	
	Height in in.	Distance in in. from clearance	Height in in.	Distance in in. from clearance		Height in in.	Distance in in. from clearance	Height in in.	Distance in in. from clearance
1	2.85	0.40	5.70	0.30	11	0.40	4.4	0.80	3.31
2	2.82	0.90	5.62	0.68	12	0.40	3.4	0.80	2.56
3	2.78	1.23	5.56	0.93	13	0.40	2.4	0.80	1.81
4	2.64	1.40	5.28	1.05	14	0.40	1.2	0.80	0.93
5	2.01	1.90	4.02	1.43	15	0.51	0.9	1.02	0.68
6	1.56	2.40	3.12	1.81	16	0.80	0.6	1.60	0.45
7	1.28	2.90	2.56	2.18	17	1.18	0.4	2.36	0.31
8	1.10	3.40	2.20	2.56	18	1.50	0.4	3.00	0.31
9	0.93	4.00	1.86	3.00	19	2.00	0.4	4.00	0.31
10	0.70	4.20	1.40	3.16	20	2.50	0.4	5.00	0.31

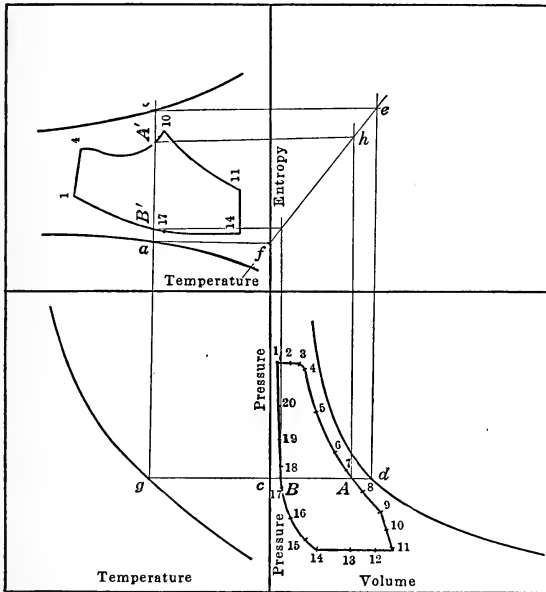

FIG. 82.—Construction of T - S diagram from p - v diagram.

This method considers only 1 lb. of steam to be present on the expansion line.

The **p-v diagram** is now laid out from the table giving the figure shown. This is then transferred from the p - v to the T - S quadrant by drawing a constant pressure line until it strikes the

saturation line in the T - p quadrant and this fixes the temperature of the point A . A vertical line from this temperature fixes a line in the T - s quadrant on which the point will lie. It would be at a if it had a quality of zero and at b if of quality 1, and in the p - v quadrant it would be at c if of zero quality and at d if of unit quality.

$$\text{Now} \quad v - v' = xv'' \quad (41)$$

$$\text{and} \quad s - s' = \frac{xr}{T} \quad (42)$$

In other words the volume change and the entropy change from liquid to steam depends on x . Hence the point A' in the T - s quadrant must divide a - b in the same way that A in the p - v quadrant bisects c - d . To construct such a point the point of intersection e of a horizontal from b and a vertical from d is joined to the intersection f of a horizontal from a and a vertical from c . The line ef is then the quality transfer line for if a vertical is drawn from A to this line intersecting it in h and then a horizontal is drawn from h to ab , this will fix the point A' . The same pressure line and construction transfers B to B' . If this is carried on in the same manner for all points a figure such as shown in the T - s quadrant, or enlarged in Fig. 83, is found in the T - s quadrant corresponding to the p - v diagram. The scales to which the p - v quadrant has been drawn were

$$1 \text{ in.} = 2.5 \text{ cu. ft.}$$

$$1 \text{ in.} = 20 \text{ lbs. per sq. in.}$$

The T - s quadrant was drawn with

$$1 \text{ in.} = 0.25 \text{ units of entropy}$$

$$1 \text{ in.} = 25^\circ \text{ F.}$$

The area scales are:

$$1 \text{ sq. in.} = \frac{2.5 \times 20 \times 144}{778} = 9.25 \text{ B.t.u. (} p\text{-}v\text{)}$$

$$1 \text{ sq. in.} = 25 \times 0.25 = 6.25 \text{ B.t.u. (} T\text{-}s\text{)}$$

The area of the indicator card on the p - v plane was 7.94 sq. in. and on the T - s plane the area was 11.76 sq. in.

These each reduce to 73.5 B.t.u. for the area.

The T - s plane for Fig. 83 has been turned through 90° . This is the conventional T - s diagram for the indicator card.

It is now necessary to add other lines to the T - s diagram in order to interpret it. Letters have been added to the diagram at critical points of Fig. 83. The diagram is for 1 lb. of total steam and this is the amount present on bc only hence the figure is true only for this short line. From the point of admission f to b there is a changing weight of steam and from c to e there is a changing weight. The points on these lines are only drawn according to the actual volumes which are proportional to entropies because each is proportional to Mx . To study the line ef on which $\frac{M_o}{M + M_o}$ pounds are present, the line corresponding to zero entropy change must be drawn. If AC be drawn so that

$$\frac{EC}{EB} = \frac{M}{M + M_o} = \frac{0.0816}{0.0905} = 0.90 \quad (43)$$

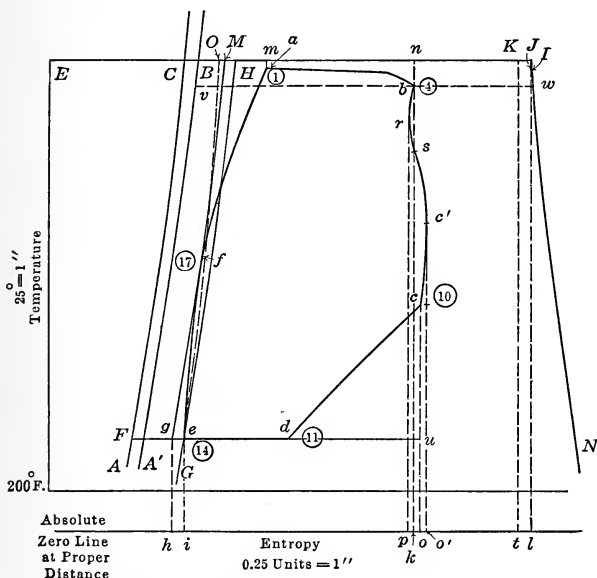

FIG. 83.— T - S diagram of indicator card.

then line AC would be the liquid line for the boiler steam only, while the distance CB or the distance between AC and $A'B$ represents entropy of the liquid for the clearance steam.

The distance ef represents the entropy of the clearance steam at the beginning of compression and GH is laid off at this distance from CFA . This line would be the line of compression if the

clearance steam did not change in entropy because the entropy of the liquid CB for this steam plus the entropy of vaporization BH is constant. GH , although not an adiabatic on this figure, is the line of compression if the clearance steam were compressed without giving up heat. The line of compression is seen to pass to the left of the line GH which means that heat is taken up by the cylinder walls. The amount of heat is found by drawing fg parallel to GH to the back pressure line ed and then dropping the perpendiculars to h and i at absolute zero of temperature getting the area $hgfei$ as the **heat removed in compression**. To find the **heat lost during admission** from f to b it is necessary to find the position which should have been occupied by the steam entering from the boiler if no heat had been taken from the clearance steam or the steam entering the engine. It is necessary to mark the line corresponding to the pressure at the throttle valve and draw this on the diagram. This will be the line $ECBH$. On this line EC is the entropy of the liquid of the boiler steam, CH is the entropy of the clearance steam and in addition to this there must be HJ for the vaporization of the steam from the boiler. If x is the quality of this steam the distance HJ is equal to

$$x \frac{M}{M + M_o} (BI) \quad (44)$$

Since BI is the value of $\frac{r}{T}$ for 1 lb. of total steam,

$$BI = BH + HI$$

The point which should have been at J is now at b and the area $nJlk$ is called the **loss due to initial condensation**. Since the reference line to care for other losses is shifted to gM the point J is moved to K and the loss due to initial condensation is $nKtk$. The area $mnba$ is called the **loss due to wiredrawing**. There is still a further loss $fMmaf$ which occurs during the early part of admission.

The area $prbk$ is the **loss to the cylinder walls after cut-off** and area $prc'o'$ represents a **gain from the cylinder walls**, and $occ'o'$ represents a **loss during the last part of expansion**.

$ksc'co - brs =$ **net gain from cylinder walls during expansion.**

$iedco =$ **heat removed during exhaust** and $dcu =$ **loss from incomplete expansion.**

Now the line GH is a liquid line for the cylinder feed and hence $ieHJl$ = the **heat supplied** with the cylinder feed for one pound of total steam, above the temperature of the exhaust.

The **work** is $efabcd$

Hence

$ieHJl + (ksc'co - srb) - abcdef - iedco - hgfei$ = **heat removed during admission.**

This will be found to be equal to the area of $fMKtkbaf$ if gf is continued to M and JK is made equal to MH .

The various losses are given as follows (numerical values should check with Hirn's analysis):

Area	Sq. in.	Per cent. of work on T°	B.t.u.
Heat supplied above exhaust = $ieHJl$ or $hgMKl$..	144.98	1232.00	905.00
Work = $efabcd$	11.76	100.00	73.50
Loss during first admission = $fMma$	0.71	6.04	4.45
Loss during throttling = $amnb$	0.30	2.55	1.88
Loss due to condensation = $nKtk$	44.32	376.20	277.00
Heat added from walls during expansion = $ksc'co - brs$	2.80	23.80	17.50
Loss due to free expansion = dcu	1.64	13.95	10.30
Heat necessarily removed during exhaust = $ieuo$..	8.43	717.50	527.00
Heat removed during compression = $hgfi$	4.74	40.40	29.60

The quality of the steam at cut-off is given on Fig. 83 by the ratio

$$x = \frac{vb}{wv} = \frac{28.8}{44.6} = 0.645 \tag{45}$$

and this can be found in the same manner for any point of the expansion curve. For the compression curve x may be found by drawing from e a line eO so that its distance from the line AC is $\frac{M_o}{M + M_o}$ times the distance from $A'B$ to IN . Thus

$$BO = BI \frac{M_o}{M + M_o}$$

If the ratio of the distance from AC to the compression line to the distance from AC to eO at the same level be found this ratio is x . AC , $A'B$ and eO make an entropy diagram for the compression steam with a bent axis AC .

As before mentioned the only true lines from which x can

be found are bc and ef . The other lines are obtained by following a scheme in which the product Mx at any point could be found but not either of the terms of the product. Hence one cannot tell what losses occur at various points on this line. There should be an agreement by the two analyses.

MISSING QUANTITY AND INITIAL CONDENSATION

Steam of quality 0.99 was admitted into a cylinder and after entering the cylinder it was found that the quality at cut-off has been reduced to 0.633. In other words 37 per cent. of the mixture is moisture. This has been caused by the action of the cylinder walls. Fig. 84 shows the **actual form** taken by the **indicator card** of an engine. The events in most cases take

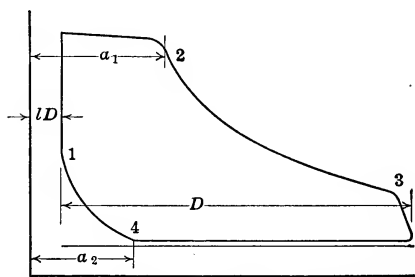

FIG. 84.—Actual indicator card from engine.

place slowly giving rounded corners; there is a drop due to throttling on the steam line and release occurs before the end of the stroke.

If the weight of dry steam shown by the cards, Fig. 84, is found by the formulæ below and this is subtracted from the amount of steam actually supplied, the difference is called the “**missing**

quantity.” It is expressed as a percentage of the steam actually supplied. It is caused by initial condensation of the steam.

$$M_a = \frac{FL}{D} \left[a_1 \times \frac{1}{v''_2} - a_2 \frac{1}{v''_4} \right] \quad (46)$$

M_a = apparent weight from diagram.

F = area of piston in square feet.

L = length of stroke in feet.

D = length of card in inches.

l = per cent. clearance from Fig. 84.

v'' = specific volume of dry steam.

a_1, a_2 = distances from clearance lines to points in inches.

If M equals the **real weight** taken per card,

$$\frac{M - M_a}{M} = \frac{M_m}{M} = m.q., \text{ missing quantity.}$$

This is almost equal to $1 - x_2$ from either of the previous analyses.

This **initial condensation** is due to the effect of the cylinder walls. As the steam in the cylinder drops in pressure its temperature changes and the moisture on the walls of the cylinder from condensation is evaporated removing heat from the metal and moisture and cooling them. During the exhaust this action continues, the walls being so cooled that when fresh steam enters the cylinder some of the steam is condensed and settles on the walls of the cylinder. This enables the walls to absorb heat from the steam at a faster rate than it would were dry vapor in contact with the metal. This condensation produces the missing quantity and the presence of a film on the walls of the cylinder seems to make it easier to carry heat to the walls during admission while during the exhaust the possibility of evaporating this water means that during this time much heat is given up by the walls and discharged with the exhaust steam when it can be of no value for driving the engine.

If superheated steam be furnished, it will give up its heat to the cylinder walls but the absence of the moisture film makes this action slower and if the superheat is sufficient the necessary heat may be abstracted before the steam is reduced to the saturated condition or before much condensation occurs. At release the absence of considerable moisture in the cylinder prevents the removal of much heat during the exhaust. Thus the superheated steam prevents the excessive abstraction of useful heat by the metal during admission and its restoration when it cannot be used. It is for this reason that superheated steam is such a valuable medium to use. This accomplishes a greater increase in efficiency than that which is shown by theoretical considerations.

To **determine the amount of steam used** by an engine it will be necessary to know this missing quantity. Then

$$M = \frac{M_a}{1 - m.q.}$$

To find the value of $m.q.$ theoretical and empirical formulæ have been proposed.

It will be evident that the amount of condensation per stroke must depend on the **surface exposed** to the steam at cut-off, the **temperature range** and the **time** during which this surface

is exposed to the steam or inversely on the **number of times** it is exposed to the action of the steam per minute. There have been several formulæ proposed. Some are quite complex taking into account many variables. The more complex, although they may be correct in theory, are so changed by slight changes in conditions that the possibility of error is as great as in the less complicated formulæ. Some of the formulæ proposed are as follows:

$$\frac{m.q.}{1 - m.q.} = \frac{217(r - 0.7)}{d\sqrt{pN}} \quad (\text{Perry}) \quad (47)$$

$$\frac{m.q.}{1 - m.q.} = \frac{15(1 + r)}{d\sqrt{N}} \quad (\text{Perry}) \quad (47a)$$

$$\frac{m.q.}{1 - m.q.} = \frac{100 \log r}{d\sqrt{N}} \quad (\text{Cotterill}) \quad (48)$$

$$\frac{m.q.}{1 - m.q.} = \frac{30\sqrt{r}}{d\sqrt{N}} \quad (\text{Thurston}) \quad (49)$$

$$m.q. = \frac{100 \, l r}{100 + l r} \quad (\text{Callendar and Nicolson}) \quad (50)$$

$$100 \, m.q. = \frac{12a(r - 1)^\alpha}{dN^\beta} \quad (\text{Rice}) \quad (51)$$

Pressure	α	β	a
60	0.568	0.412	133
80	0.517	0.384	106
100	0.466	0.359	87
120	0.414	0.333	78
140	0.363	0.306	75

In the above formulæ,

r = ratio of expansion, the volume at end of stroke divided by the volume at cut-off.

d = diameter in inches.

p_1 = absolute steam pressure in lbs. per sq. in.

N = r.p.m.

l = percentage clearance.

$$m.q. = c \left\{ [T_b - T_e] d \cos^{-1} \frac{(1 - 2b)}{\pi} + [T_b - T_e] \right. \\ \left. (127e + 0.055)s \right\} \frac{\pi d}{2N} \quad (\text{Marks}) \quad (52)$$

$c = 0.02$.

T_b = abs. temp. at cut-off.

- T_e = abs. temp. during exhaust.
- d = diam. in feet.
- e = fraction of volume at cut-off.
- s = stroke in feet.
- b = fraction of volume at compression.

$$m.q. = \frac{0.27}{\sqrt[3]{N}} \sqrt{\frac{sT}{ep}} \quad (53)$$

$m.q.$ = missing quantity for small compression or $(1 - x)$ at cut-off for large compression.

N = r.p.m.

s = nominal cylinder surface divided by volume, each in feet, = $\left(\frac{2}{L} + \frac{4}{d}\right)$.

T = temperature range from **limiting pressures** on curve Fig. 85. $(T_1 - T_2)$

p = abs. pressure at cut-off in lbs. per sq. in.

e = ratio of total volume at cut-off to volume swept out by piston.

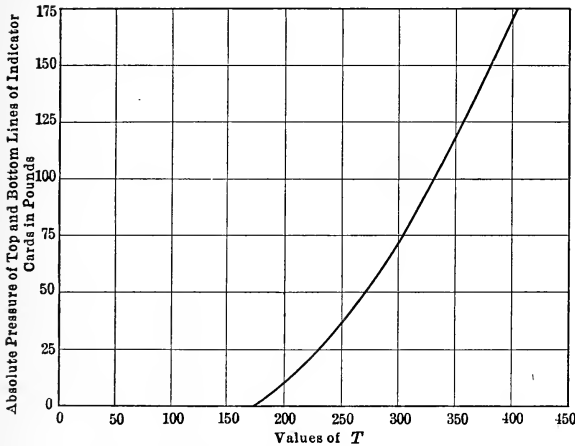

FIG. 85.—Heck's value of T for different pressure.

The basis for the form of these formulæ may be given as follows:

The surface exposed to the steam at cut-off in square feet is

$$2 \frac{\pi d^2}{4} + \pi d \frac{1}{r} L + F_p = F_c \quad (54)$$

d = diam. in feet.

L = stroke in feet.

$\frac{1}{r}$ = point of cut-off.

F_p = surface of passages.

The time during which this is exposed is

$$k \frac{1}{N} \text{ minutes}$$

where k = a fraction less than 1
 N = r.p.m.

The temperature range for this surface is some function of T . It is not equal to the actual difference in the temperatures at cut-off and compression as the range in temperature in the metal is much less than this. The quantity of steam necessary to give the heat per stroke required by the cylinder walls will be proportional to the surface, time and temperature range, or

$$M_s = k' F_c \frac{1}{N} f(T) \quad (55)$$

To express this as a fraction, $m.q.$, of the steam shown by the indicator card it must be divided by the steam shown by the card. This steam is given by

$$M_a = \frac{\frac{1}{r} \left[\frac{\pi d^2}{4} L \right]}{v''_2} - \text{compression steam.} \quad (56)$$

Now the specific volume $v''_2 = \frac{k''}{p}$ approximately since the curve of saturated steam on the p - v plane is nearly a rectangular hyperbola. (See Fig. 96.)

$$M_a = k''' \frac{p}{r} \frac{\pi d^2}{4} L \text{ (approx.)}$$

Hence

$$\frac{M_s}{M_a} = \frac{m.q.}{1 - m.q.} = m.q. \text{ (approx.)} = k^{iv} \frac{1}{N} f(T) \frac{F_c}{\frac{\pi d^2}{4} L} \frac{r}{p} \quad (57)$$

Now $\frac{F_c}{\frac{\pi d^2}{4} L}$ may be called s . F_c is practically equal to $2 \frac{\pi d^2}{4} +$

πdL , so that $s = \frac{2}{L} + \frac{4}{d}$

This is a function of $\frac{1}{d}$ giving

$$m.q. = k^{rv} \frac{1}{N} \frac{sr}{p} f(T) \text{ or } k^v \frac{1}{N} \frac{r}{pd} f(T) \quad (58)$$

If r is written as $\frac{1}{e}$, e , being the relative total volume at cut-off this reduces to

$$m.q. = \frac{k^{rv}}{N} \frac{s}{pe} f(T) \quad (59)$$

By examining a number of tests of all sorts of engines and with different speeds, pressures and cut-offs for the same engine, investigators have been led to the empirical forms shown above. What in the simple theory appears as the first power has in general been changed to a fractional power. In all of the simpler formulæ the form agrees in the positions of the terms with the simple theoretical form shown. In place of $\frac{k}{N}$ being used for the time term $\frac{1}{\sqrt{N}}$ or $\frac{1}{\sqrt[3]{N}}$ has been used. Heck assumes that the last two terms of F_c are equal to πdl , thus making F_c equal to the inside surface of the piston displacement,

$$F_c = \pi d \left(\frac{d}{2} + l \right)$$

From evidence shown by those who have derived these formulæ it appears that the formula of Heck

$$m.q. = \frac{0.27}{\sqrt[3]{N}} \sqrt{\frac{sT}{pe}} \quad (57)$$

is a good one to use. It is applicable to non-jacketed engines when supplied with dry steam. For this reason it cannot be used when the supply is superheated steam nor for the lower cylinders of multiple expansion engines when the steam supply is quite wet. If, however, this steam is dried by a separator or by reheater coils before entering the other cylinder, it may be used. For jacketed engines it might be used by deducting the surfaces heated by the jacket from the area F_c in finding this or the quantity s .

This formula shows that the proportional amount of condensed steam varies inversely as the square root of the cut-off getting less as the cut-off becomes greater. This must not be confused

with the actual amount of steam condensed which will not vary very much as the cut-off changes. The large part of the condensation takes place when the steam first enters the cylinder and as the piston moves along the additional amount is not great. The surfaces which are most important in the condensation of steam are the cylinder head and piston. For this reason greater gain is to be expected from the jacketing of the heads than from the jacketing of the barrel of the cylinder. It might pay to supply the hollow piston with steam, making a jacket of the cored spaces. The value of s decreases as the size of the cylinder increases giving less condensation in large cylinders than that found in small ones.

This is to be applied to the card below, Fig. 86, which is the assumed card in the design of a 20-in. \times 24-in. engine to run at 80 r.p.m. The clearance is 7 per cent.; cut-off is at 25 per cent. Pressure at cut-off is 125 lbs. abs. and back pressure 17 lbs. abs.

$$s = \frac{2}{24} + \frac{4}{20} = 1 + 2.4 = 3.4$$

$$\left. \begin{array}{l} T_{125} = 360 \\ T_{17} = 217 \end{array} \right\} \text{From curve, Fig. 85.}$$

$$T = 360 - 217 = 143$$

$$e = 0.25 + 0.07 = 0.32$$

$$m.q. = \frac{0.27}{\sqrt[3]{80}} \sqrt{\frac{3.4 \times 143}{125 \times 0.32}} = 0.219$$

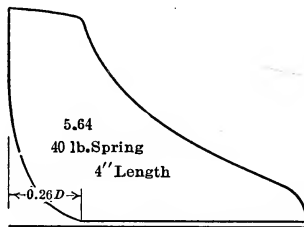

FIG. 86.—Card for proposed 20 \times 40 engine.

Amount of steam indicated at cut-off is given by

$$M_i = (0.25 + 0.07) \left[\frac{24}{12} \times \frac{\pi \times 10^2}{144} \right] \frac{1}{v''_{125}}$$

$$= \frac{0.32 \times 4.36}{3.581} = 0.390 \text{ lbs.}$$

$$\text{Steam at compression} = \frac{0.33 \times 4.36}{23.38} = 0.0615$$

$$\text{Indicated steam per hour} = (0.390 - 0.0615) \times 80 \times 2 \times 60 \\ = 3160 \text{ lbs.}$$

$$\text{Probable steam per hour} = \frac{3160}{1 - 0.219} = 4000 \text{ lbs.}$$

$$\text{Mean height} = 1.41 \text{ in.}$$

$$\text{m.e.p.} = 56.4$$

$$\text{H.p.} = \frac{56.4 \times \frac{24}{12} \times 314 \times 80}{33000} \times 2 = 172$$

Probable steam consumption,

$$\text{Steam cons.} = \frac{4000}{172} = 23.2$$

This result is low so that the missing quantity will be computed by some of the other formulæ.

By Perry's formula (48)

$$\frac{m.q.}{1 - m.q.} = \frac{15 \left[1 + \frac{1.07}{0.32} \right]}{20 \times \sqrt{80}} = 0.37 \\ m.q. = 0.271$$

By Thurston's formula

$$\frac{m.q.}{1 - m.q.} = \frac{30 \sqrt{\frac{1.07}{0.32}}}{20 \times \sqrt{80}} = 0.31 \\ m.q. = 0.237$$

By Cotterill's formula

$$\frac{m.q.}{1 - m.q.} = \frac{100 \log \frac{1.07}{0.32}}{20 \times \sqrt{80}} = 0.293 \\ m.q. = 0.226$$

The result of 23.2 lbs. per hour per horse-power was low for this type of engine so that Heck's formula would not give as good results as Thurston's, Perry's and Cotterill's. If 0.30 is taken for the value of $m.q.$ The steam consumption is equal to

$$24.3 \times \frac{1 - 0.219}{1 - 0.30} = 27.2 \text{ lbs.}$$

On account of valve leakage this result would be increased slightly.

EXPERIMENTS OF EFFECT OF CYLINDER WALLS

This **influence of the cylinder walls** has been experimentally studied by a number of investigators. **Callendar and Nicolson**, in their paper presented in the "Proceedings of the Institution of Civil Engineers of Great Britain," Vol. cxxxi, gave results obtained by them on a $10\frac{1}{2} \times 12$ Robb engine in 1895 with a flat slide valve behind a pressure plate. The piston displacement was 0.601 cu. ft. and the clearance volume was 0.060 cu. ft. The engine was made single-acting so as to study the action in a better manner. To find the temperature of the metal in the cylinder head eight holes were drilled at regular intervals at $1\frac{1}{2}$ in. from the center of the head but extending to different depths. The thicknesses of metal remaining at the bottom of seven of these holes were 0.01 in., 0.02 in., 0.04 in., 0.08 in., 0.16 in., 0.32 in. and 0.64 in. Along the length of the cylinder at the end of stroke and at 4, 6 and 12 in. from it a pair of holes were drilled in the side, one to within 0.04 in. of inner surface and the other $\frac{1}{2}$ in. At 2, 8, 10, 14 and 16 in. from the end single holes were drilled leaving $\frac{1}{2}$ in. at bottom. There were also four holes at the middle of the stroke distributed around the circumference of the cylinder extending to within $\frac{1}{2}$ in. of the inner surface and finally three vertical holes two inches deep were drilled along the side of the barrel at 1 in., $7\frac{1}{2}$ in. and 15 in. for the use of mercurial thermometers or platinum resistance thermometers, while in the other holes thermocouples were used.

The **thermocouples** were made by soldering wrought-iron wires at the bottom of the holes. To make the cold junction, the same kind of wire was attached to cast-iron blocks cast from the same ladle as that from which the head was cast. These were immersed in a paraffine bath at 212° F. The potential was measured by a very sensitive galvanometer by balancing the potential on a potential wire. The formula for the voltage in microvolts produced by this couple was found to be given by

$$E = 1692 - 17.86t + 0.0094t^2 \quad (58)$$

if the cold junction was at 100° C. and the hot junction at t° C. Later one of the couples in the cylinder was used as the cold

junction and the drop of temperature between these two was measured.

This method was somewhat similar to that used by Prof. E. Hall of Harvard (Trans. A. I. E. E., 1891) but his results were not very extensive.

To find the temperature of steam the authors used a platinum resistance thermometer in the cylinder 3 in. from the face of the piston and also one in a small $\frac{3}{8}$ -in. hole in the center of the piston head.

To get the temperature at a definite point in the stroke by any couple or platinum thermometer a pair of revolving brushes were attached to the shaft. One brush made contact with a central copper tube and the other with a sector mounted on a circular disc. The sector was one-thirtieth of a circumference in length. The disc could be rotated and by a scale and vernier the position of the crank for any observation could be read. A number of sectors on the disc reduced the amount of motion neces-

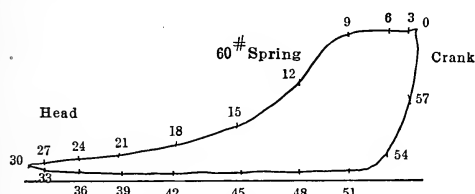

FIG. 87.—Indicator card marked with points at various sixtieths of a revolution. From 20 × 40 engine.

sary. To facilitate the change of circuit to different couples, mercury cups were used.

To show the results of these tests, Fig. 88 has been constructed from the card, Fig. 87 by finding the saturation temperature for pressures of the steam at points corresponding to definite crank angles. This temperature from the steam tables is plotted to sixtieths of a revolution, giving the curve. The marks × give points similar to the results shown by the platinum thermometer while the points marked ○ show the temperatures of the thermometer in the steam space in the cylinder head. The curves illustrating the variation of temperature of the metal at $\frac{1}{25}$ in. from the inside surface in the head and that at holes in the side at 4 in. from end are shown to a larger scale above the card. These curves are ideal and are drawn to indicate the results of Callendar and Nicolson.

The surprising results of the actual tests by Callendar and Nicolson were that at $\frac{1}{100}$ in. from the inside surface the variation of temperature was only 4.3° F. at 100 r.p.m., while at $\frac{1}{25}$ in. from inside the variation was 6° F. at 46 r.p.m. and 4° F. at 73.4 r.p.m. At $\frac{1}{2}$ in. from the inside the change in temperature due to cyclic variation was practically zero.

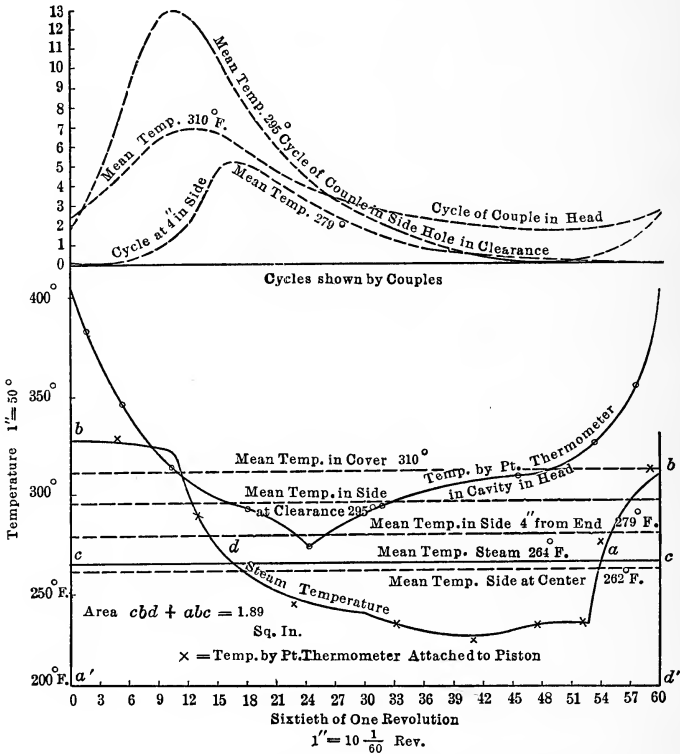

FIG. 88.—Diagram of temperature at various positions of piston for different movement of crank. Temperatures taken in head, cylinder wall and steam space. (After Callendar and Nicolson.)

Along the length of the barrel the first hole situated in the clearance space and exposed to the same steam action as the heads showed 13.5° F. variation at $\frac{1}{25}$ in. from inside at 44 r.p.m. when the heads at this thickness showed 4.9° F. variation. This amount of 13.5° F. at $\frac{1}{25}$ in. from the surface probably corresponds to about 20° F. variation at the surface and this particular result was the largest obtained by the experimenters. The

variation at 4 in. was found to be 5° F. and at 6 in., $3\frac{1}{2}^{\circ}$ F. It was found that these temperatures begin to rise before the piston reaches these points showing that there was conduction along the barrel and also the steam could leak around the piston as far as the rings. A curious result near the middle of the stroke is the temperature that is shown on the inner surface which is lower than that some distance farther out. This shows that there is a flow of heat from the metal to the steam at this point. The experiments seem to show a gradient of 0.55° F. per inch in the head while that on the side wall of the barrel was a variable quantity in an axial direction being greatest at the center of the stroke where it was 9.3° F. per inch.

Experiments were made to determine the **conductivity** of cast iron giving 5.5 B.t.u. per square feet per degree per hour for 1 in. thickness and then the **diffusivity**, which is the ratio of this conductivity to the thermal capacity of the same amount of metal, was computed.

The results of these experiments showed that the effect of moisture in the steam is to increase the condensation while superheat decreases it. The percentage amount of condensation varies inversely as the ratio of expansion making the actual amount of condensation practically constant. The effect of initial pressure is complex so that an increase does not mean an increase in condensation and the same may be said of the change in back pressure. Early compression means a shorter time for cooling and hence decreases the condensation. Jacketing reduces the surface which causes condensation and for that reason reduces the amount of condensation.

To find the **maximum condensation** possible, the **limiting amount** as they called it, the average height of the **temperature degree diagram**, Fig. 88, is found and when the area above this line is expressed in degrees and sixtieths of a cycle it will give the thermal units per hour per square foot when multiplied by 45. The surface considered for 20 per cent. cut-off on this engine which was a Corliss engine was 8.9 sq. ft. on each end.

$$45 \times \text{Area } (cbd + abc) \times \text{scale} \times \text{surface of clearance} = 45 \times 1.89 \times 10 \times 50 \times 8.9 \times 2 = \text{Total B.t.u. of condensation per hour} = 758,000 \quad (59)$$

This quantity is then multiplied by

$$\frac{1 + \sqrt{N}}{3 + \sqrt{N}} \text{ or } \frac{\sqrt{N}}{3 + \sqrt{N}} \quad (60)$$

to make it correct for the speed of N revolutions per minute for cut-off or release respectively; while multiplying by 1.4 gives the result for a double-acting cylinder.

Thus, from the Fig. 88, the following results for a 20 in. \times 42 in. engine at 80 r.p.m.:

$$758,000 \times \frac{1 + \sqrt{80}}{3 + \sqrt{80}} \times 1.4 = 884,000 \text{ B.t.u. per hr.}$$

If the pressure at entrance from the card were 100 lbs. absolute for which $r = 887.6$, the steam condensed per hour will be

$$M = \frac{884000}{887.6} = 997 \text{ lbs.}$$

This engine uses 4000 lbs. of steam per hour so that the missing quantity is 0.25.

The **actual condensation** may be much less than this and, if the mean temperature of the cylinder wall is known, the area above this line to any event gives the actual condensation when handled in the manner shown. The net area to a point beyond the crossing of the mean line gives the difference between the condensation and the reevaporation. The multiplier is different for cut-off and release.

VALVE LEAKAGE

Callendar and Nicolson found that in their engine much of the **apparent missing quantity** was due to **leakage of steam** beneath the valve into the exhaust and this steam never entered the cylinder. The **valve leakage** of steam was found to depend on the periphery of the valve, the lap and the pressure difference or

$$W = \frac{Kl(p_1 - p_2)}{s} \quad (61)$$

when p_1 and p_2 were the mean pressures on the two sides in pounds per square inch, s was the lap in inches and l was the periphery in inches.

The value of this leakage term was undoubtedly large in the experiments under review but in many engines it may be a small quantity. In the engine used K was equal to 0.02.

The platinum thermometer projecting into the steam of the cylinder 3 in. from the piston face indicated (Fig. 88) that

the steam was practically saturated except during compression when it was superheated, while that in the $\frac{3}{8}$ -in. hole in the piston head was highly superheated during all of the stroke except at cut-off. This was undoubtedly due to the superheating effect of the metal when the pressure was low causing the steam to be superheated still further during compression.

George Duchesne in the *Revue de Mechanique*¹ gives results of an investigation with a **hyperthermometer** which consisted of a multiple silver-platinum couple 0.002 mm. thick. This couple responded rapidly to the changes of temperature. He finds the cycle of Fig. 89 for the wall, steam and the saturation temperature of the steam in his engine on a temperature-piston travel diagram. In this it is noted that the wall temperature is usually higher than the steam and that the steam is saturated except during compression when it is superheated, becoming saturated at the point where it reaches the wall temperature. Of course this metal

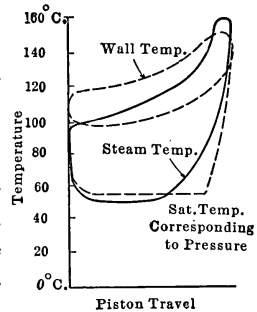

FIG. 89.—Results of Duchesne on temperature of wall and steam.

cycle is true for one point in the cylinder but for another point the cycle would probably be lower. Duchesne states that the compression should not be carried higher than the temperature of the metal of the head for, if this is done, a loop is found on the card, Fig. 90. That this loop is due to excessive condensation was proven by the fact that, when air was used with this amount of compression, the loop was not shown, compression being carried up to a higher pressure. The loop may not be found in high-speed engines when the piston speed is faster than the speed of condensation.

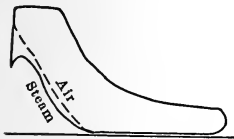

FIG. 90.—Duchesne compression loop due to excessive compression.

This **compression**, however, does not affect the steam consumption very greatly as has been shown by Prof. John Barr² in 1895 and by E. Heinrich³ in 1913. In these experiments there was a slight change in the steam per indicated horse-power hour

¹ *Revue de Mechanique*, 1897, pp. 925 and 1236. *Power*, June 28, 1910; May, 1911.

² *Trans. A. S. M. E.*, 1895, p. 430.

³ *Zeit. des Verein Deutscher Ing.*, Vol. 58, Jan. 3, 1914.

with change in compression but this was very slight. Heinrich found that by adding plates and increasing the clearance surface, although the volume remained the same, the water rate was increased, showing the harmful effect of surface.

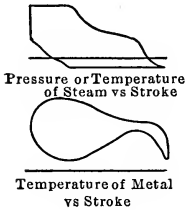

FIG. 91.—Adams' results.

In 1895, at Cornell University, Mr. E. T. Adams used a couple in the cylinder wall near the inside surface ($\frac{1}{100}$ in.) and attached it to a galvanometer of short period. He photographed the beam of light from the mirror of the galvanometer on a sensitive paper moved by the piston. This result is shown in Fig. 91, which shows a rapid drop at the opening of release probably due to the evaporation of water from the surface and, as the heat flowed in from the outer metal of the wall, this temperature rose again.

STEAM CONSUMPTION BY CLAYTON'S METHOD

J. Paul Clayton¹ has studied the results of actual tests of engines and has shown that the expansion lines of steam engines and, in fact, the expansion lines from any engine using an elastic medium are polytropic curves of the form $pv^n = K$ unless there is some peculiarity such as leakage or some other disturbance which is not uniform. He then investigated the values of n from different engines, finding the value of n by plotting a logarithmic diagram of pressure and volume as shown for the cards of Fig. 92 taken from a 20 in. \times 42 in. engine at 78 r.p.m. with 4 per cent. clearance. The table below shows the method of constructing the diagram Fig. 93. If the clearance is properly measured and the correct scale of the spring is used, the expansion lines become straight lines on the logarithmic diagram and the slopes of these lines are the values of n since

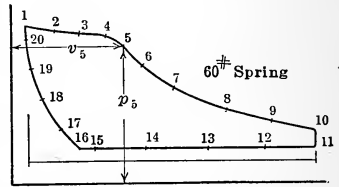

FIG. 92.—Card from engine for Clayton analysis.

$$n = \frac{\log p_1 - \log p_2}{\log v_2 - \log v_1} \quad (62)$$

¹ Trans. A. S. M. E., 34, p. 17.

Bulletin 58, Engineering Experiment Station, Univ. of Illinois.
Bulletin 65.

The variation of this line from a straight line, as shown in the figure, would indicate leakage.

Point	Volume in fifths inches from clearance line	Logarithm of volume in fifths inches + 1	Pressures in fifths inches from absolute zero	Logarithm of pressure in fifths inches + 1
1	0.70	0.846	8.65	1.936
2	2.20	1.340	8.40	1.924
3	3.88	1.590	8.30	1.919
4	5.50	1.740	8.28	1.918
5	6.25	1.795	7.97	1.902
6	7.47	1.873	6.50	1.813
7	9.35	1.970	5.20	1.716
8	12.80	2.106	3.80	1.579
9	15.85	2.200	3.15	1.498
10	18.92	2.276	2.05	1.424
11	17.80	2.250	2.18	1.338
12	15.20	2.182	1.88	1.274
13	12.55	2.099	1.85	1.267
14	9.50	1.978	1.80	1.255
15	5.70	1.756	1.80	1.255
16	3.52	1.546	1.75	1.243
17	2.80	1.447	2.00	1.301
18	1.75	1.240	3.15	1.498
19	1.25	1.096	4.35	1.638
20	0.70	0.846	7.20	1.864

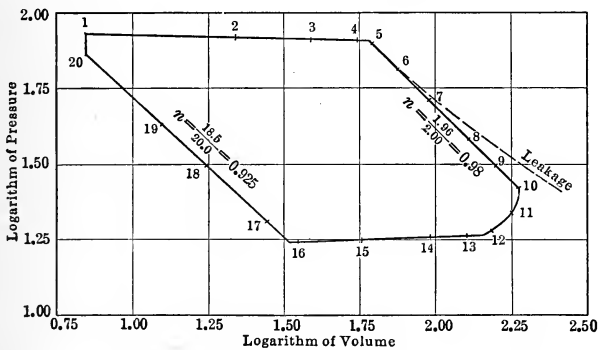

FIG. 93.—Logarithmic diagram of steam engine indicator card.

In preparing the table, distances to the true zero of pressure and of volume have been found and then the distances from these lines to any point have been measured in fifths of an inch. The logarithms of the numbers have been increased by unity to have

all of the numbers positive for plotting. This only shifts the lines but does not change the slopes.

The logarithms are then plotted giving the figure which also shows the true point of closing or opening of the valve as the point at which the straight line begins marks the beginning or ending of the expansion or compression. This is of value as the events, especially compression are difficult to fix accurately on the indicator card.

On investigating tests on which the quality of the steam in the cylinder could be determined from data and on making such tests on an engine in the laboratory where the quality of steam

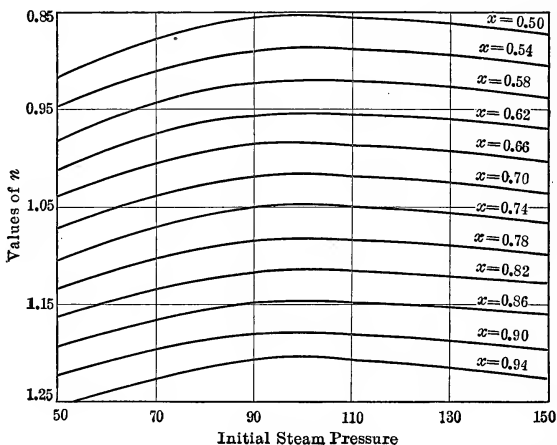

FIG. 94.—Clayton's relations between n , x , and p for stationary engines.

at cut-off could be varied by using wet steam or superheated steam, Clayton showed that there was a variation of the value of n of the expansion line and the quality of steam at cut-off. The value of n varied from 0.70 to 1.34 while the quality at cut-off varied from about 0.4 to 0.9. He showed that there was a relation between them. In steam engines the value of n of the expansion line could be told from the quality at cut-off or, conversely, knowing n the quality at cut-off could be found. This relation changes with the steam pressure and with the speed but does not vary with the point of cut-off. Since in stationary engines the variation with the speeds in use is slight, the only variation considered is the variation with pressure and Fig. 94 has been prepared from a similar figure due to Clayton giving the values

of x and n at different pressures. For locomotive work, where the pressures do not vary much, Clayton gives a figure similar to Fig. 95 showing the values of x and n at different speeds.

The results have been obtained from non-jacketed engines exhausting near the atmospheric pressure and hence the results should only be applied to such. The method, if used with jackets or with high back pressure can only be considered an approximation. The indicator must be connected directly to the cylinder without the use of piping and a correct reducing motion with no stretch nor lost motion must be employed.

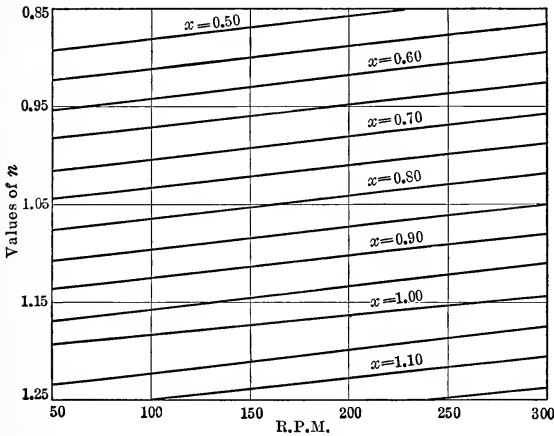

FIG. 95.—Clayton's relations between N , n , and x for locomotive engines.

On actually applying this method, a result close to the correct steam consumption may be found by assuming dry steam at compression. The error may be 4 per cent. The results for Fig. 92 will be computed.

Value of n for expansion curve, Fig. 93, = 0.98

Steam pressure, 108 lbs. abs.

x , from Fig. 94, for $n = 0.98$ and $p = 108$, is 0.65

Pressure at cut-off, 93 lbs. abs.

Length to cut-off, 1.22 in.; to comp., 0.73 in.; of card, 3.14 in.

$$\text{Total volume at cut-off} = \frac{1.22}{3.14} \times \frac{314 \times 42}{1728} = 2.96 \text{ cu.ft.}$$

Weight of dry steam at 93 lbs. = 0.2112 lbs. per cu. ft.

$$\begin{aligned} \text{Weight of steam per hour at cut-off} &= \frac{2.96 \times 78 \times 60 \times 0.2112}{0.65} \\ &= 4470 \text{ lbs.} \end{aligned}$$

$$\text{Volume at compression} = \frac{0.73}{3.14} \times \frac{314 \times 42}{1728} = 1.76$$

$$\text{Pressure at compression} = 24 \text{ lbs. abs.}$$

$$\text{Weight of clearance steam per hour} = 1.76 \times 78 \times 60 \\ \times 0.0591 = 486$$

$$\text{Steam supplied} = 4470 - 486 = 3984 \text{ lbs. per hour}$$

$$\text{H.p.} = 160 \text{ h.p.}$$

$$\text{Steam per i.h.p.-hour} = \frac{3984}{160} = 24.8 \text{ lbs.}$$

VALUES OF n FOR EXPANSION LINES

Clayton has found by logarithmic diagrams that the value of n for the expansion line of the steam engine varied from 0.835 to 1.234 and that the average with saturated steam in the steam pipe was 0.947 while with superheated steam the value was 1.056 and the average of all tests was 1.004. The value of $n = 1$ which is so common in the theoretical discussion of indicator cards of steam engines is not far from the truth. The ease of construction of the rectangular hyperbola, $pv = \text{constant}$, and the simple results it leads to in practice are good reasons for its common use. Of course it has no theoretical basis and is only used for the reasons given above.

In steam engines actually examined by Clayton the expansion line had values of n near 1 in all cases except poppet valve engines, where n rose to 1.3 with highly superheated steam and in the Stumpf Straight Flow Engine with superheated steam where n was 1.2. The compression lines were mostly near $n = 1$ although some values much lower were found.

In gas engines n for expansion varied from 1.09 to 1.36 while n for compression varied from 1.09 to 1.43. Güldner, according to Clayton, gives values of n from 1.30 to 1.38 for compression and 1.35 to 1.50 for expansion. The latter is due to hot water. He states that Burstall gives 1.288 as the average for expansion and 1.352 for compression in gas engines.

For compressed air locomotives Clayton found $n = 1.35$ while on air compressors it was 1.26.

For ammonia compressors the cards examined gave values averaging $n = 1.20$.

On gas compressors the value is $n = 1.14$. This is very low.

While discussing this value of n it is well to remember that, although the equation of the adiabatic of steam is

$$s' + \frac{xr}{T} = \text{const. or}$$

$$s' + \frac{xr}{T} + \int \frac{c_p dt}{T} = \text{const.}$$

the line is sometimes put in the approximate form

$$pv^n = \text{const.}$$

$$n = \frac{10}{9}, \text{ according to Rankine} \quad (63)$$

$$n = 1.035 + 0.1x, \text{ according to Zeuner} \quad (64)$$

$$n = 1.059 + 0.000315p + (0.0706 + 0.000376p)x$$

according to E. H. Stone (65)

p = pressure at point where quality is x

x = quality at highest point .

For superheated steam,

$$p(v + 0.088)^{1.305} = \text{const. (Goodenough)}$$

EXPANSION LINES

It will be well at this point to examine the difference between various lines of expansion which may occur in the steam engine cylinder to see what error might be made in assuming one rather than another in the theoretical discussion of indicator cards. The discussion and curves will also indicate how close the lines approach each other.

Using the results of Clayton, suppose that an engine with cut-off at $\frac{1}{4}$ stroke and with 10 per cent. clearance has steam of a quality of 0.70 at 115 lbs. absolute pressure and it is required to draw the following lines through this point:

- (a) Rectangular hyperbola
- (b) Adiabatic
- (c) Isodynamic
- (d) Constant steam weight, $x = \text{const.}$
- (e) $pv^n = \text{const.}$ of Clayton, $n = 1.02$
- (f) $pv^{1.2} = \text{const.}$
- (g) $pv^{0.8} = \text{const.}$

From Clayton's diagram, $n = 1.02$.

The diagram for 1 lb. of steam will be computed and tabulated below for pressures at 20-lb. intervals to points beyond the actual length of card. The computations for the first points are given.

$$V_1 = Mxv'' = 1 \times 0.70 \times 3.876 = 2.71 \text{ cu. ft.}$$

$$p_1 = 115 \text{ lbs.}$$

For $p_2 = 95 \text{ lbs. abs.,}$

$$(a) V_2 = 2.71 \times \frac{115}{95} = 3.28 \text{ cu. ft.}$$

$$(b) x_2 = \frac{0.4881 + 0.70 \times 1.1026 - 0.4699}{1.1363}$$

$$= 0.695$$

$$V_2 = 0.695 \times 4.644 = 3.23 \text{ cu. ft.}$$

(b_a) Stone's value of n ,

$$n = 1.059 - 0.000315 \times 115 + (0.0706 + 0.000376 \times 115)0.70$$

$$n = 1.102$$

$$V_2 = 2.71 \left(\frac{115}{95} \right)^{\frac{1}{1.102}} = 3.23 \text{ cu. ft.}$$

$$(c) q'_1 + x_1\rho_1 = q'_2 + x_2\rho_2$$

$$x_2 \times 808.8 = 309.0 + 0.70 \times 797.0 - 294.6$$

$$x_2 = 0.708$$

$$V_2 = 0.708 \times 4.644 = 3.28 \text{ cu. ft.}$$

$$(d) V_2 = 0.70 \times 4.644 = 3.25 \text{ cu. ft.}$$

$$(e) V_2 = 2.71 \left(\frac{115}{95} \right)^{\frac{1}{1.02}} = 3.28 \text{ cu. ft.}$$

$$(f) V_2 = 2.71 \left(\frac{115}{95} \right)^{\frac{1}{1.2}} = 3.17 \text{ cu. ft.}$$

$$(g) V_2 = 2.71 \left(\frac{115}{95} \right)^{\frac{1}{0.8}} = 3.41 \text{ cu. ft.}$$

TABLE OF VOLUMES

Pressure	$n=1$	Adiabatic		Isody- namic	$x = \text{const.}$	$n=1.02$	$n=1.2$	$n=0.8$
		Theory	Stone					
115	2.71	2.71	2.71	2.71	2.71	2.71	2.71	2.71
95	3.28	3.23	3.23	3.28	3.25	3.28	3.17	3.41
75	4.15	4.00	4.01	4.15	4.07	4.13	3.88	4.62
55	5.67	5.30	5.31	5.66	5.45	5.60	5.02	6.82
35	8.90	8.00	8.00	8.82	8.32	8.70	7.34	11.95

The tables show the close agreement of the line $pv^{1.102}$ with the adiabatic and Fig. 96 shows how closely the rectangular hyper-

bola, the Clayton line, the adiabatic, the isodynamic and the constant steam weight curves come together. The lines vary slightly. If the card *abcd* is worked out for the various lines it is found that although the mean effective pressure for the lines $pv^{0.8}$ and $pv^{1.2}$ vary 12 per cent. from the mean of the two, the variation on the lines $pv^{1.02}$ and $pv^{1.1}$ which are the extremes of the remaining lines vary from the hyperbola by 5 per cent., or, 5 per cent. is the maximum variation in general. The value 1.2

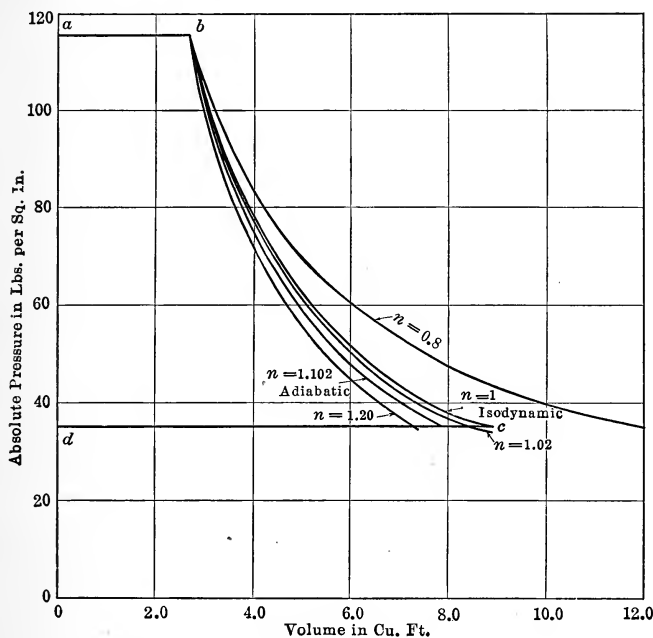

FIG. 96.—Variation in various expansion curves. Constant steam weight curve lies between adiabatic and $pv^{1.02} = \text{const.}$ Isodynamic can not be separated from curve $pv = \text{constant}$.

is found on engines using superheated steam and the variation in the m.e.p. for the card with this line is 14 per cent. from that with the rectangular hyperbola.

USE OF RECTANGULAR HYPERBOLA

From the above it will be seen that in general the rectangular hyperbola will give areas within 2 per cent. of the actual cards for ordinary engines although with superheated steam or very wet steam the use of the rectangular hyperbola for the ex-

pansion line may result in an error of less than 15 per cent. in the area of the indicator card. Since the errors due to rounding of the corners or the intersection of the various cards of a multiple expansion engine may lead to as great errors, the simplicity in the calculations and constructions when this line is assumed makes this curve of value in the preliminary design of an engine. When the probable condition of the steam is known the exact exponent may be used.

CONSTRUCTION OF EXPANSION CURVES

To draw the rectangular hyperbola the graphical construction shown in Fig. 97 is used. Given the original point 1, a horizontal and a vertical line are drawn through 1. If, from a , b and c , on the horizontal line, slanting lines are drawn to the origin

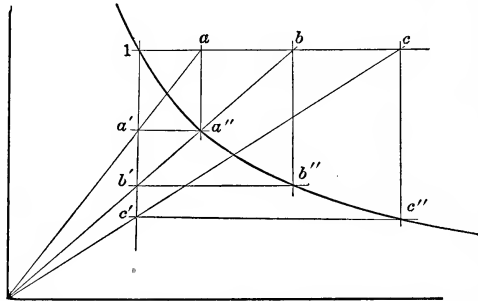

FIG. 97.—Construction of rectangular hyperbola.

of pressure and volume, they will cut the verticals in a' , b' and c' . Verticals from a , b and c intersect horizontals from a' , b' and c' in a'' , b'' and c'' which are points on the rectangular hyperbola.

The student may see that this curve fulfills the equation of the hyperbola since

$$\begin{aligned} p_1 &= p_a \\ p'_a &= p''_a \\ v_1 &= v'_a \\ v''_a &= v_a \end{aligned}$$

From similar triangle $\frac{v_a}{v'_a} = \frac{p_a}{p'_a}$

Substituting the values above

$$\frac{v''_a}{v_1} = \frac{p_1}{p''_a}$$

or

$$p''_a v''_a = p_1 v_1$$

The graphical construction usually employed for the polytropic, $pv^n = \text{constant}$, is open to an accumulative error and for that reason, although correct geometrically any slight error of one point is increased in the later points and hence the best way to construct the curve is to assume a ratio of two pressures, say $\frac{p_2}{p_1} = r$, and to use this to compute all successive points.

$$\begin{aligned} p_2 &= rp_1 \\ p_3 &= rp_2 \\ p_4 &= rp_3 \end{aligned}$$

In this way successive pressures can be read from a slide rule without moving the middle scales by setting the zero of the *C* scale at the value of *r* on the *D* scale.

Since

$$\frac{p_2}{p_1} = \left(\frac{v_1}{v_2}\right)^n$$

$$\frac{v_2}{v_1} = \left(\frac{1}{r}\right)^{\frac{1}{n}} = r''$$

The successive volumes are given by

$$\begin{aligned} v_2 &= r''v_1 \\ v_3 &= r''v_2 \\ v_4 &= r''v_3. \dots \end{aligned}$$

The *p*'s and *v*'s being known, the curve may be plotted quickly. Thus suppose the line

$$pv^{1.4} = \text{constant}$$

is desired to pass through $p = 125$ lbs. abs. and 2.5 cu. ft. Assume $r = 0.5$.

$$\left(\frac{1}{r}\right)^{1.4} = \left(\frac{1}{0.5}\right)^{1.4} = 2.64 = r''$$

<i>P</i>	125.0	62.5	31.7	15.7	7.8	3.9
<i>V</i>	2.5	6.6	17.4	46.0	122.0	323.0

MEAN EFFECTIVE PRESSURE

To find the **probable mean effective pressure** for an engine on which the cut-off and limiting pressures are known but for which the clearance and compression are not known as the pre-

liminary dimensions have not been found, the best procedure is to assume zero clearance and zero compression and to allow for the effect of these by empirical constants. The card *abcde*, Fig. 98, shows the theoretical card in this case. If r is the apparent ratio of expansion, ab will equal D/r if ed is assumed equal to D . The area is given by

$$\text{area} = \frac{D}{r} p_1 + \frac{D}{r} p_1 \log_e \frac{D}{\frac{D}{r}} - p_b D$$

$$\text{m.e.p.} = \frac{\text{area}}{D} = \frac{p_1}{r} [1 + \log_e r] - p_b \quad (66)$$

This is the formula by which the mean height may be found if the line is assumed to be the rectangular hyperbola. For the line $pv^n = \text{const.}$

$$\text{m.e.p.} = \frac{p_1}{r} \left[1 + \frac{1 - r^{1-n}}{n - 1} \right] - p_b$$

for all values of n except 1.

If clearance is added to the diagram as shown in the right-hand Fig. 98, the expansion line will be raised and for that reason the

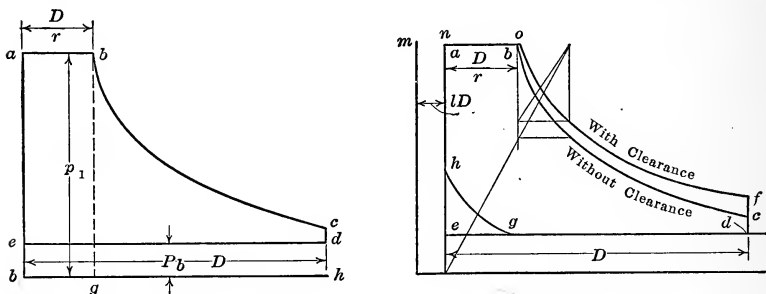

FIG. 98.—Theoretical indicator cards, showing effect of clearance and compression.

area will be increased. On the other hand, the presence of compression in the cylinder reduces this area. The card is then *abfcgdh*. From a number of cards drawn with different clearances, pressures and cut-offs the net result of these two effects was to decrease the area or m.e.p. by 2 per cent. The variation found was from 3 per cent. to 1 per cent.

REAL AND APPARENT RATIO OF EXPANSION

In Fig. 98, D/on is the **apparent ratio of expansion** while D/om is the **real ratio of expansion**. The first is called r and it is the

reciprocal of the cut-off. If the clearance is lD , the real ratio of expansion is

$$r_r = \frac{(l + e)D}{\left[\frac{l}{r} + l\right]D} = \frac{(l + e)r}{1 + lr}$$

The actual card $ab'c'de'f'$, Fig. 99, differs from the theoretical card $abcdef$ at several points. In most cases the steam is throttled or wire-drawn during admission. This causes the line ab in high-speed engines to drop about 10 per cent. in pressure although in Corliss engines the line is nearly horizontal. Moreover, with slide valves, the slow closing of the valve causes further throttling and causes the corner to be rounded. The expansion line bc is of the form $pv^n = \text{const.}$, the value of n depending on

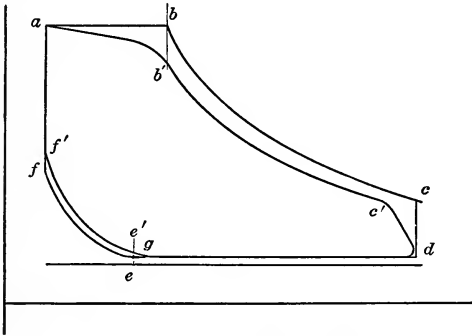

Fig. 99.—Actual and theoretical cards compared.

the quality at b . The release takes place at c' before the end of the stroke giving the line $c'd$. The back pressure line should be that assumed, as the actual value is taken in theory. This is from $\frac{1}{2}$ to 2 lbs. above the pressure in the region into which exhaust takes place. At the end of exhaust the back pressure line will rise due to the slow closing of the exhaust valve so that the point of compression e' is raised above e . This gives the line $e'f'$ distinct from ef . In actual cards such a point as g is considered as the point of compression but, as was pointed out in the logarithmic diagrams, this point is not on the compression line. The ratio of the actual area to the theoretical area is known as the **diagram factor**.

$$\frac{\text{Area } (ab'c'de'f')}{\text{Area } (abcdef)} = \text{diagram factor.}$$

The value of this for single cylinder engines is about 0.90. The actual m.e.p. is then given by

$$\text{m.e.p.} = 0.90 \times 0.98 \left[\frac{p_1}{r} (1 + \log_e r) - p_b \right] \quad (68)$$

If the two factors are combined in a single factor known as the **combined factor**, this may be found from the results of an engine test by the following formula:

$$\begin{aligned} \text{combined diagram factor} &= \frac{\text{actual m.e.p.}}{\text{theoretical m.e.p.}} \\ &= \frac{\text{i.h.p.} \times 33000}{2FLN} \times \frac{1}{\frac{p_1}{r} (1 + \log_e r) - p_b} \end{aligned} \quad (69)$$

Tests give the value of this to be about 0.85 for high-speed engines.

To find the **value of the m.e.p.** it is necessary to assume or know the values of p_1 , p_b and r . For ordinary single cylinders the value of p_1 is usually 90 lbs. gauge to 125 lbs. gauge unless it is desired to get great power or force from a relatively small cylinder when a much higher pressure is used. If high pressure is used **cut-off** must be made **very early** so that the expansion of the steam may be utilized completely. This, however, causes the **percentage effect of initial condensation** to be

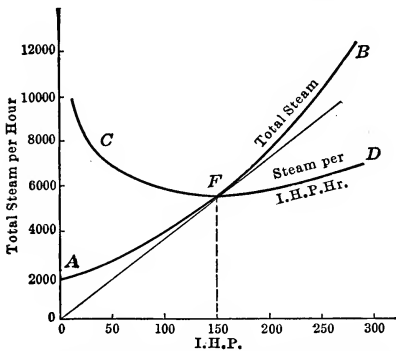

FIG. 100.—Steam consumption curves.

felt although the higher temperature range gives a higher theoretical efficiency. To reduce this loss a **later cut-off** is used giving an **excessive loss due to free expansion**. This same reasoning holds for the determination of the best value of r . If r is **large** the steam is **used to advantage expansively** but the **percentage effect of initial condensation** is **great** while for a **smaller value of r** this **condensation effect** is **smaller** but there is a loss from **free expansion**.

If the **results** of a test are **plotted** with indicated horse-power as abscissæ and total weight of steam per hour as ordinates, the most efficient point is found at the point of tangency of a straight line from the origin as this gives the smallest ratio of ordinate

to abscissa which is the steam per horse-power hour. In Fig. 100 this relation is seen for the curve *AB*. If the ratios of ordinates to abscissæ are found for different points, the steam consumption curve *CD* is found on which *F* is the best point.

Heck proposes that the weight of steam per hour be divided by the displacement per hour giving the weight of steam used per cubic foot of displacement. In this case the line *AB* would take the same form because the displacement per hour which is $\frac{120FLN}{144}$, is a constant for Fig. 100.

- F* = area of piston in square inches.
- L* = stroke in feet.
- N* = revolutions per minute.

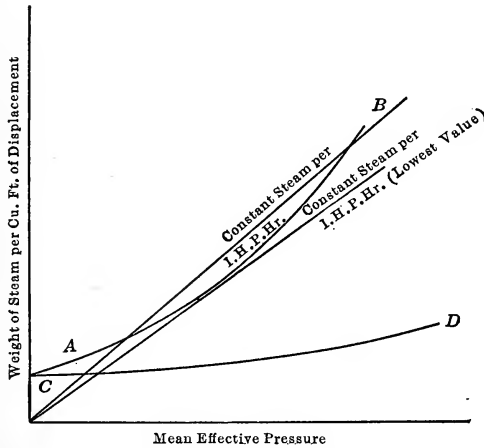

FIG. 101.—Curves of steam per cu. ft. of displacement for different mean effective pressures.

This quantity is called m_f , weight per cubic foot of displacement.

Now
$$m_f = \frac{\text{wt. per hr.}}{\frac{120 FLN}{144}} = \text{const.} \times \text{wt. per hr.}$$

$$\text{i.h.p.} = \frac{2p_m FLN}{33000}$$

from which
$$p_m = \frac{33000 \text{ i.h.p.}}{2FLN} = \text{const.} \times \text{i.h.p.} \tag{70}$$

In Fig. 101 the line *AB* drawn with p_m and m_f as coordinates is the same curve as used before with a new scale. The weight

of steam per cubic foot of piston displacement from the indicator card, Fig. 102, when the missing quantity is $m.q.$, is

$$\frac{\left[\frac{\left(l + \frac{1}{r} \right) D}{v''_b} - \frac{(l+x)D}{v''_e} \right] \frac{1}{1 - m.q.}}{D} = \left[\frac{\left(l + \frac{1}{r} \right) 1}{v''_b} - \frac{l+x}{v''_e} \right] \frac{1}{1 - m.q.}$$

$$= m_f = \frac{1}{(rv''_b)(1 - m.q.)} \text{ approximately. } (71)$$

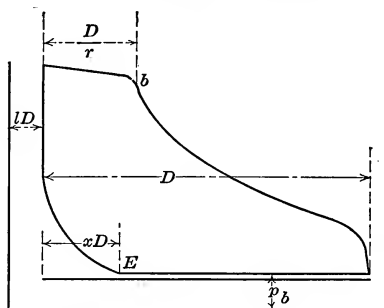

FIG. 102.—Card for the computation of steam weight.

Now the steam per indicated horse-power hour is

$$M_1 = \frac{m_f \frac{2FL}{144} N \times 60}{\frac{2p_m FLN}{33000}} = \frac{13750m_f}{p_m} \quad (72)$$

or

$$m_f = \frac{M_1}{13750 p_m} \quad (73)$$

That is, straight lines from the origin of Fig. 101 are lines of constant steam consumption; the consumption being equal to 13,750 times the ratio $\frac{m_f}{p_m}$ or the inclination of the lines.

The theoretical amount of steam per cubic foot of cylinder volume is

$$m_f = \frac{1}{rv''_b} = \frac{m_o}{r} = k \frac{p_1}{r} \quad (74)$$

since the volume at cut-off is $1/r$ and the specific weight of steam is

$$\begin{aligned} m_o &= a + bp \\ &= bp \end{aligned} \quad (75)$$

if a is neglected because of small value. This results from

plotting the specific weights and pressures of the steam tables as shown in Fig. 103. This shows clearly that the value of m_o is practically bp .

$$\begin{aligned}
 \text{Now} \quad p_m &= \frac{p_1}{r} [1 + \log_e r] - p_b \\
 kM_1 &= \frac{m_f}{p_m} = \frac{k \frac{p_1}{r}}{\frac{p_1}{r} [1 + \log_e r] - p_b} \\
 &= \frac{1}{[1 + \log_e r] - kr \frac{p_b}{p_1}} \tag{76}
 \end{aligned}$$

In other words M_1 decreases as the expansion increases since $\log_e r$ increases faster than $r \frac{p_b}{p_1}$

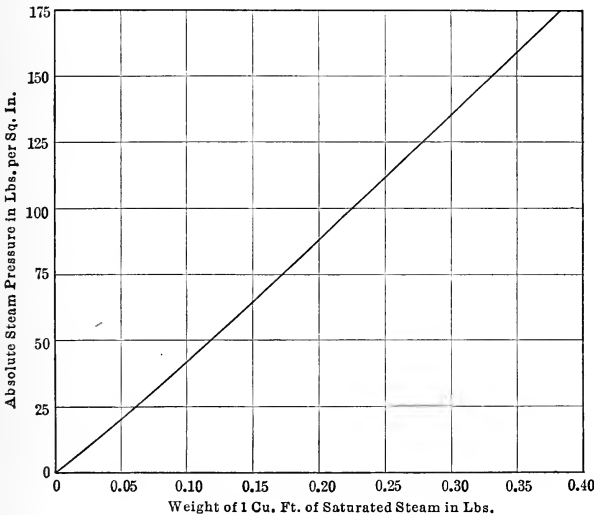

FIG. 103.—Curve of relation between pressure and weight of 1 cu. ft. of steam.

The amount of initial condensation per cubic foot of cylinder displacement varies slightly with r ; that is, as p_m increases the condensation increases slightly. CD will represent the initial condensation in Fig. 101. The distance from AB to DC will be the amount shown by equation (74). From this figure M_1 can be found as well as from (76).

The best point is usually found at about $\frac{1}{4}$ or $\frac{3}{8}$ cut-off with single cylinders of the ordinary form.

While discussing steam consumption it will be well to call attention to the **Willans straight line law** for the steam consumption of throttle-governed engines. For a given ratio of expansion and back pressure

$$\begin{aligned}
 p_m &= cp_1 - p_b \\
 \text{i.h.p.} &= \frac{2(cp_1 - p_b)FLN}{33000} \\
 M_{total} &= \frac{2LFN \times 60}{144} \times \frac{kp_1}{r} = \frac{2LFN}{144} \times \frac{60k}{cr} \left[\frac{33000 \text{ i.h.p.}}{2FLN} + p_b \right] \\
 &= k' \text{ i.h.p.} + k''p_b = a \text{ i.h.p.} + b \qquad (77)
 \end{aligned}$$

or, the total weight of steam per hour with a throttle valve engine varies with the horse-power on a straight line.

STUMPF ENGINE

Although in the ordinary engine the best point of cut-off seems to be about one-fourth stroke, in a single cylinder engine developed by Prof. Stumpf in 1910 the cut-off is carried very early since the initial condensation is reduced by the arrangement of the engine. This is the **uniflow (unidirectional flow) or straight flow engine** shown in Fig. 104. This was invented independently by Stumpf although a similar idea had been developed by Bowen Eaton in 1857, by E. Roberts in 1874 and by L. J. Todd in 1885. In this engine steam is allowed to enter from the valve *A* behind a long piston *B* and forces it to the right. After the piston moves a short distance to the right, steam is cut off by the **double beat valve** and the steam expands to nine-tenth of the stroke when the piston overrides **ports C**, cut in the cylinder barrel, allowing steam to exhaust through *D* to the condenser or atmosphere. The area thus available is so great that the pressure rapidly falls and when the piston returns and covers this the steam has dropped to the pressure of the condenser or atmosphere. The compression then begins and, by properly selecting the clearance, the final pressure is made equal or nearly equal to the boiler pressure. This clearance depends on the back pressure and, if this is liable to change very much, arrangements are made to vary the compression or clearance. Thus, with a condensing

cylinder, when it is necessary to start at atmospheric pressure until the air pump connected with the engine has produced the proper vacuum, an auxiliary clearance volume is connected to the cylinder and is controlled by a valve so that it may be connected when necessary.

As the steam expands in the cylinder, it becomes wet due to the work done, as is known from the discussions of the adiabatic for steam. The supply steam in the hollow head *D*, however,

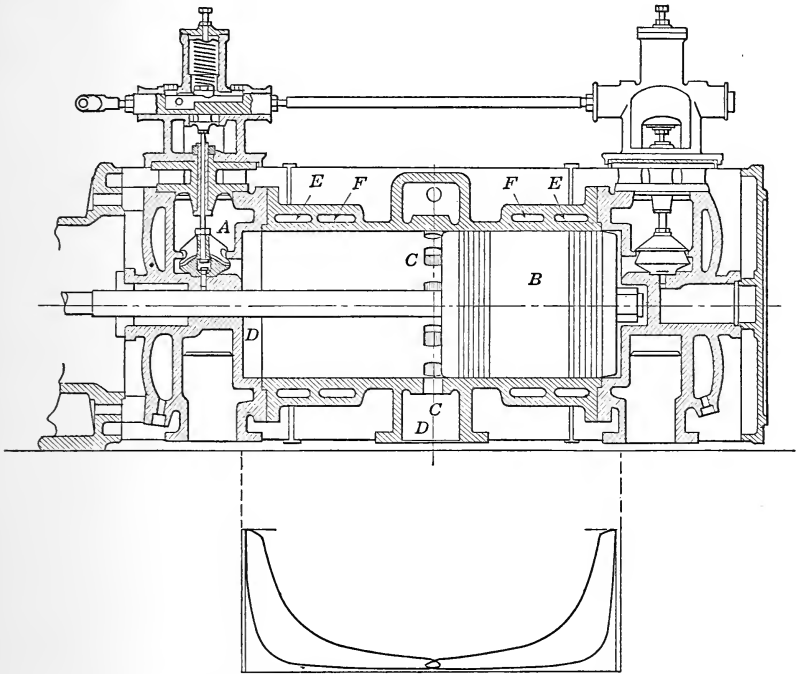

FIG. 104.—Cylinder of Stumpf engine with indicator card.

warms the steam in the cylinder in contact with the head and keeps it dry or superheats it as the pressure falls. As the steam is discharged outward at the end of the stroke the steam next to the head expands, driving the wet steam before it, and leaves the cylinder practically full of dry steam. As the piston returns the steam compressed is superheated as it starts from a dry or even superheated condition. This steam gives up heat to the piston head so that the steam entering the cylinder meets a piston surface that is warm while the head and walls are heated

to the temperature of the incoming steam on one side and to a temperature higher than this by the superheated steam on the other side. The part of the cylinder near the center which is in

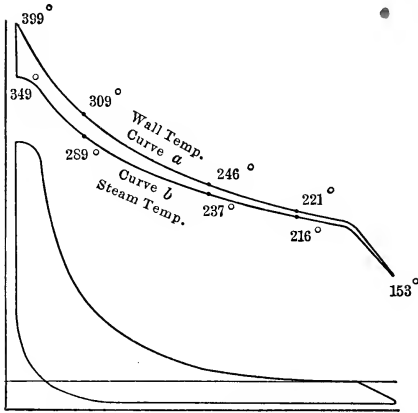

FIG. 105.—Curve showing temperature of wall and saturated steam for different positions of piston as found by Stumpf.

contact with the low pressure or exhaust steam is cut off by the piston from contact with the fresh steam. The curves of Fig. 105 made by Stumpf show how the wall temperature (*a*) varies along the cylinder of a condensing engine compared with the temperature (*b*) of the saturated steam corresponding to the pressure when the piston is at various points. The fact that the metal line is above the saturation line indicates that superheated steam must be

present and this is only possible on compression. The cool central portion of the cylinder is a good feature structurally for lubrication as at this location the piston is moving at its

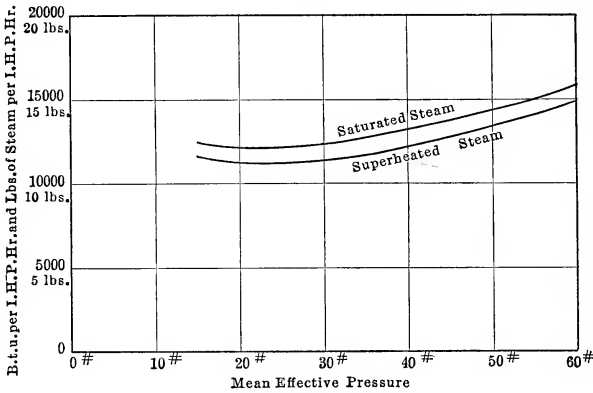

FIG. 106.—Steam consumption and heat per h.p. hr. curves of Stumpf engine.

highest speed. Stumpf claims that the steam in this engine does not enter in a disturbed condition and that it flows always toward the exhaust. This, of course, cannot be true for,

until release, the action is the same as in any engine, but, at release, the steam which has been dried or superheated by the jacketed head drives out the wet steam, whereas, in the ordinary return flow engine, this steam is the first to leave. The distribution of the exhaust around the circumference gives an undisturbed discharge although it tends to remove any moisture from the piston face. The jacket head being in the steam supply is a bad feature as this would introduce wet steam into the cylinder unless superheated steam is used. The effect then would be to reduce the amount of superheat only and in one test this amounted to 54° F. or 27 B.t.u. per pound of steam. The chambers *E* and *F* are jackets for the barrel and the steam gradually passes from one to the other and with this a drop in pressure causes a drop in temperature. To show the efficiency of this engine, Fig. 106 is presented. This is from a test of a 300 h.p. engine tested with saturated steam and superheated steam of 580° F. at 135 lbs. absolute pressure. The results are plotted for pounds per horse-power hour and actual B.t.u. per horse-power hour chargeable to the engine plotted against m.e.p. They show the closeness of results with saturated and superheated steam, the slight variation with great change in load and values, which are ordinarily obtained with multiple expansion engines. This engine illustrates the great value of expansion when the effects of initial condensation can be eliminated.

SIZE OF ENGINES

To find the probable size of an engine to deliver a given horse-power, the formula for horse-power is used

$$\frac{\text{b.h.p.}}{\text{mech. eff.}} = \frac{2pFLN}{33000} \quad (78)$$

p = m.e.p. in pounds per square inch.

F = area of piston in square inches.

L = stroke in feet.

N = revolutions per minute.

In this equation p has been determined from the formula (68) after p_1 , p_b and r have been assumed. N is fixed by the purpose for which the engine is to be used or by the valve gear. For Corliss engines, N varies from 60 to 120. For connected valve gears, N may be as high as 450. The allowable piston

speed, $2LN$, then fixes L . This varies from 250 in small engines to 1000 in larger engines. The only unknown is now F by which the diameter is fixed.

To apply this, suppose it is desired to find the size of an engine to drive a 125 kw. generator.

$$\text{i.h.p.} = \frac{\text{kw.}}{0.746 \times 0.90 \times 0.90} = 1.6 \text{ kw.} = 1.6 \times 125 = 200 \text{ i.h.p.} \quad (79)$$

This number, 1.6, is an important average number to keep in mind for rapid computations. The following assumptions will be made: $p_1 = 125$ lbs. abs., $p_b = 17$ lbs. abs., $r = 4$, $2LN = 500$, $N = 275$.

$$\begin{aligned} \text{m.e.p.} &= 0.90 \times 0.98 \left[\frac{125}{4} (1 + 2.3 \times 0.602) - 17 \right] \\ &= 50.9 \text{ lbs. per square inch} \end{aligned}$$

$$L = \frac{500}{2 \times 275} = 0.91 \text{ ft.} = 10.9 \text{ in.}$$

$$F = \frac{\text{i.h.p.} \times 33000}{2pLN} = \frac{200 \times 33000}{2 \times 50.9 \times 0.91 \times 275} = 259 \text{ sq. in.}$$

$$d = \sqrt{\frac{4F}{\pi}} = \sqrt{\frac{4 \times 260}{\pi}} = 18.2 \text{ in.}$$

The size of cylinder necessary would therefore be 18 in. diameter \times 12-in. stroke, the somewhat unusual ratio of diameter to stroke being caused by a desire to keep the piston speed low.

The effect of clearance on an engine is largely dependent on the amount of surface exposed. The volumetric clearance does not seem to have much effect on the efficiency. Tests have been made on an engine with varying amounts of clearance and the results have shown little change in steam consumption. The effect of clearance surface as shown by Heinrich has been mentioned on p. 209. General practice, however, is to cut the clearance to a minimum so as to increase the area of the indicator card for a given displacement and to make the steam loss due to improper compression with different cut-offs as small as possible.

BEST POINT OF COMPRESSION

The effect of compression is very slight as is shown theoretically and by the tests of Heinrich but to determine the best point

The relation which gives maximum work under this change with constant volume of working steam is given by equating the derivative to zero.

$$\begin{aligned} \frac{d(\text{m.e.p.})}{d\left(\frac{1}{r}\right)} = 0 &= p_1 + p_1 \log_e \frac{1+l}{\frac{1}{r}+l} - p_1 \left[l + \frac{1}{r} \right] \frac{\frac{1}{r}+l}{1+l} \frac{1+l}{\left(\frac{1}{r}+l\right)^2} \\ &+ p_1 - p_1 \log_e \frac{l + \frac{1}{r} - x''}{l} \frac{p_1}{p_b} - p_1 \left(l + \frac{1}{r} - x'' \right) \frac{1}{l + \frac{1}{r} - x''} \\ p_1 \log_e \frac{1+l}{\frac{1}{r}+l} &= p_1 \log_e \frac{l + \frac{1}{r} - x''}{l} \frac{p_1}{p_b} = p_1 \log_e \frac{l+x}{l} \\ \frac{1+l}{\frac{1}{r}+l} &= \frac{l+x}{l} \end{aligned} \tag{80}$$

or the point of cut-off divides a line from the end of the card to the axis of volume in the same proportion as the clearance divides a line to the axis of volume from the point of compression.

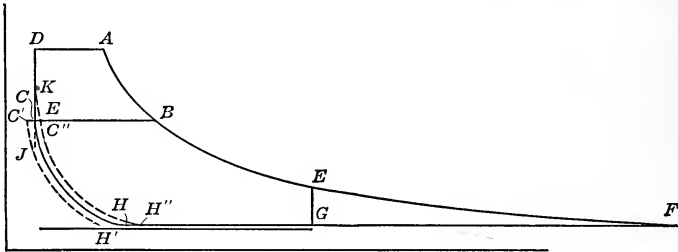

FIG. 108.—Webb's method of finding compression point.

Another method of finding the point of compression as given by Webb in the American Machinist for 1890 is to carry out the expansion line to the back pressure line as in Fig. 108 and then lay off CB so that the area $ABCD$ is equal to area EFG . The point C is then taken as the end of compression. The basis of this construction is the fact that, by changing the area $ABCD$ to EFG , the card $CBEFGH$ will have the same area as $ABEGHC$ and will use the same weight of steam since this is proportional to the line CB . The card $CBEFGH$ has complete

expansion and must have complete compression to overcome the effect of clearance. For instance, if the line $H'C'$ were used for the compression line, the area $C'CHH'$ would have to be saved to make up for the additional steam CC' since

$$\frac{C'CHH'}{C'C} = \frac{CBEFGH}{CB}$$

But the area $JC'C$ is not obtained and hence the gain of area $JCHH'$ is not proportional to the increase in the steam quantity $C'C$.

If the line were $H''C''K$, then the saving in steam would be CC'' but the lost work would be $H''HCKC''$. This is greater than the proportional reduction $H''HCC''$ by the area CKC'' and hence this does not pay.

Figs. 107 and 108 are for the same conditions and the results are practically the same.

Of course the constructions above are true if the steam is assumed dry or proportional in all cases to the length of the line between the compression and expansion lines.

The methods of Clark, see his *Steam Engine*, p. 399, and of Ball, *A.S.M.E.*, xiv., p. 1067, may be referred to by the student. Clark's method is the equivalent of the two methods given above although the results are given in the form of a table.

Having the compression desired, the pressures, the cut-off, release and clearance from the design of the cylinder, the probable card for an engine may be drawn and studied.

SPEED

The **speed of an engine** affects its efficiency in changing the amount of condensation. As this varies inversely as the cube root of the number of revolutions per minute it would naturally be expected that high-speed engines would be the more efficient. That this is not so is due to the fact that the term s varies inversely as the linear dimension of the engine and hence this term is so small for large engines that it overbalances the effect of the slower speed. For instance, if the piston speed, $2LN$, is fixed, the initial condensation will vary approximately inversely as the cube root of N and also inversely as the square root of L . Hence it would pay to make L large and N small. This is the actual result in practice. The large, slow-speed pumping

engines represent the best type of engines using saturated steam.

The **effect of superheat** has been explained and results given at the end of Chapter II show that this materially affects the

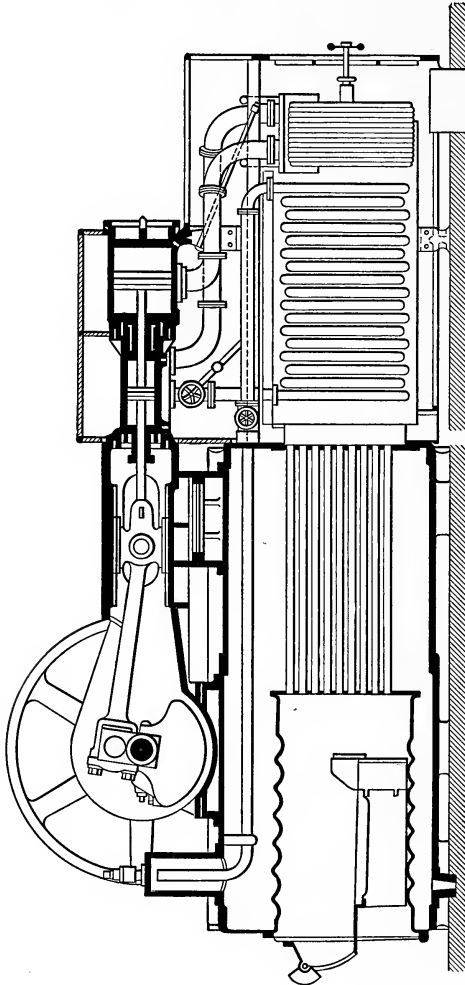

FIG. 109.—Locomotive of Buckeye Co.

condensation and increases the efficiency a greater amount than that estimated by theory.

The **effect of the jacket** on a cylinder is a debated question. The results shown by the committee of the Institution of Me-

chanical Engineers of Great Britain indicate a distinct gain. Other tests made on large engines show no gain and, in a few cases, a loss. Of course the total steam used by the engine is always considered in these cases. In most instances the important saving has been found on small engines of less than 300 h.p. For large engines the results will vary. Ten to 15 per cent. may be saved on engines of 200 or 300 h.p. One form of jacket which has been used on the type of semiportable engine known as the **locomobile** is of value. In this unit the engine is mounted on top of the boiler, Fig. 109, and the exhaust gases from the boiler pass around the cylinder, thus heating it to a high temperature. These units have the condensation reduced to such a degree by this jacket combined with the use of superheated steam that they give a brake horse-power hour on $10\frac{1}{2}$ lbs. of steam 1.25 lbs. of coal or 210 B.t.u.

Effect of regulating by **throttling steam** and **changing cut-off** may be seen when the formula (53) is noted. In this the quantity s changes slightly with the cut-off and so there is a slight increase in the steam due to this. With throttling, however, there is an amount of available energy lost apparently. When it is remembered that this energy is used in changing the quality of the steam which becomes drier or superheated, it is seen that when the steam enters the cylinder it is in such a condition that the initial condensation is less and hence the loss due to this effect is smaller. So great is this reheating effect with throttling that, even with this steam of reduced availability the steam consumption is as low as with engines in which the cut-off is varied. A number of years ago the author experimented on a small engine, controlling it by automatic cut-off and by throttle governing, and both curves, similar to CD , Fig. 100, were coincident throughout their range. The curves will indicate the steam for either of these methods and also how the consumption varies with the load.

TOPICS

Topic 1.—Sketch the Rankine cycle of the steam engine with complete expansion and compression and explain the difference between this and the Carnot cycle. Explain the variation in quality on the various lines in these two cycles. Show that clearance has no effect in this case when initial condensation is not present.

Topic 2.—Sketch the Rankine or Clausius cycles with complete expansion and incomplete expansion on the $p-v$ and $T-S$ planes and derive the various

expressions for efficiency. Explain why the cards may be drawn with no compression lines.

Topic 3.—Sketch the T - s diagram of a Rankine cycle with incomplete expansion and discuss the value of increasing the steam pressure, vacuum or amount of superheat. Does the increase of vacuum always pay? Why?

Topic 4.—Sketch and explain action of the Barrus calorimeter. Give the method of computing results. Explain what is meant by a dry test, how it is made and for what it is used? What is a separating calorimeter? What is the formula for x when this instrument is used. What is an electric calorimeter? What are constant immersion thermometers? Why are they used? What is the purpose of the upper thermometer of the Barrus calorimeter?

Topic 5.—What is Hirn's analysis? For what is it used? What observations are made? Explain how the quantities M_o and M are found. Explain how x_1 , x_2 , and x_3 are found. Explain how AU_1 , AU_2 , AU_3 and AU_4 are found. Explain how Q_1 and Q_2 are found.

Topic 6.—Given the average indicator card, show how the quantities AW_a , AW_b , AW_c and AW_d are found. Give method of changing from square inches to B.t.u. Having the U 's, Q 's and AW 's explain how Q_a , Q_b , Q_c and Q_d are found. What check equation may be used for these quantities? How is the new quantity for this check equation found? What difference does a jacket make in these equations?

Topic 7.—What is the temperature-entropy analysis? What readings are necessary? Explain how the curves of the quadrants are constructed and sketch the diagram. How is the average indicator card found and how is this transferred to the p - v quadrant of the diagram.

Topic 8.—Explain how to transfer the diagram from the p - v quadrant to the T - s quadrant. Explain the method of finding the various losses. Which lines on the diagram are true? Why can the diagram be used for other lines?

Topic 9.—What is initial condensation? How large may it be? To what is this due? What is the missing quantity? In what units is it found? Explain how it may be found from a test. Explain what is meant by the terms of the two formulæ below:

$$\frac{mq}{1 - mq} = \frac{30 \sqrt{r}}{d \sqrt{N}}$$

$$mq = \frac{0.27}{\sqrt[3]{N}} \sqrt{\frac{sT}{pe}}$$

Topic 10.—Derive the formulæ:

$$M_s = K'Fc \frac{1}{N} fT$$

$$m.q. = K^v \frac{1}{N} \frac{r}{pd} fT$$

Why is it that it may be said that $v''_2 = \frac{K''}{p}$? What is Heck's expression for s ? Using Heck's formula $m.g. = \frac{0.27}{\sqrt[3]{N}} \sqrt{\frac{ST}{pe}}$ discuss the effect of size,

speed, pressure and cut-off on the actual condensation and on the percentage condensation, *m.g.*

Topic 11.—Give a statement of the work of Callendar and Nicolson, Hall, Duchesne and Adams on the effect of cylinder walls. How do Callendar and Nicolson plot their results so that initial condensation may be found? What do their results show in regard to variation of steam temperature in the cylinder, and in a small hole in the head? What is the nature of the temperature cycle at various points in the cylinder length and at various depths? Which has the greater effect, clearance surface or clearance volume? When does the major part of the initial condensation take place? To what is it due?

Topic 12.—Explain Clayton's method of finding the quality at cut-off, constructing the diagram from the indicator card. Show how to find the probable steam consumption from the indicator card. Explain how leaks are detected. Explain how to locate the events of the stroke properly.

Topic 13.—What values of *n* are to be expected on various machines on compression and expansion? Explain how the following curves may be constructed on the *pv*-plane: (a) rectangular hyperbola, (b) adiabatic, (c) constant steam weight curve and (d) $pv^{1.05} = \text{const.}$ What conclusions may be drawn from the figure in the book showing the various expansion curves?

Topic 14.—Explain how to construct the curves $pV = \text{const.}$ and $pV^n = \text{const.}$ through a given point p_1V_1 . Find the area of the indicator card for each of these to a volume V_2 and pressure p_2 if the back pressure is *p*. From this find the formulæ for the m.e.p.

Topic 15.—Explain what is meant by the real and apparent ratio of expansion. Derive a formula for the real ratio of expansion in terms of the apparent ratio, *r*, and the clearance, *l*. What is meant by diagram factor? How is it found? What value does it have?

Topic 16.—Sketch the curve of total steam consumption and show how to find from this the curve of steam consumption per horse-power hour. Explain why this curve is the same as the curve between m_f and p_m . What is the Willans straight-line law? Prove that it is true.

Topic 17.—What is the Stumpf engine? Why is it of value? Sketch it. Sketch curves showing the temperatures of the wall and saturated steam for various positions along the length of the cylinder. What conclusion may be drawn from this? Sketch the cards from this engine. How is compression cared for when high back pressure exists in starting a condensing Stumpf engine with a direct-connected air pump?

Topic 18.—Explain how to find the indicated horse-power required to produce a given kilowatt output from a direct-connected generator. Show how to find the size of an engine to produce this power.

Topic 19.—Derive the formula for the best point of compression.

Topic 20.—Sketch the constructions for the best point of compression due to Stumpf and to Webb. What is the effect of speed? Of superheat? Of jackets? What difference is found between governing by throttling and by automatic cut-off?

Topic 21.—Sketch and explain particular features of the locomobile.

PROBLEMS

Problem 1.—Find the various efficiencies of an engine with $p_1 = 120$ lbs. gauge pressure, $p_2 = 30$ lbs. gauge pressure, $p_3 = 2$ lbs. gauge pressure if $x_1 = 0.99$ and 35 lbs. of steam are needed per i.h.p.-hr.

Problem 2.—One engine uses 25 lbs. of steam per i.h.p.-hr. with steam at 125 lbs. gauge pressure and of quality 0.995. The back pressure is 2 lbs. by gauge. By using steam of 200° F. superheat the steam consumption is reduced to 22 lbs. per i.h.p.-hr. What was the saving?

Problem 3.—An engine uses 3500 lbs. of steam per hour, of which 300 lbs. is used in the jackets and 200 lbs. in the receiver. The steam supply is at 150 lbs. gauge pressure with 175° F. superheat. The temperature of the return from the jackets is 320° F., while the return from the receiver is 338° F. and the hot well temperature from the condensate is 95° F. The engine develops 250 h.p. Find the B.t.u. per h.p.-min. Find the actual efficiency. If the mechanical efficiency of the pump and engine combined is 92 per cent., what is the duty of this engine?

Problem 4.—In Fig. 68 assume that the pressure on the top line is 120 lbs. absolute and on the lower line is 15 lbs. absolute. Suppose that the quality on the top line is 0.98, assuming the cycle to be the Rankine cycle, and that it varies from 0.03 to 0.98 if assumed to be the Carnot cycle. Find the qualities at the lower corners. Find the heats on the four lines.

Problem 5.—In a Rankine cycle with complete expansion the pressure varies from 125 lbs. gauge to 0 lbs. gauge with $x_1 = 1.0$. Find the efficiencies, η_1, η_2, η_3 . Increase the upper pressure to 150 lbs. gauge and, leaving the other quantities unchanged, find η_1, η_2 and η_3 . With 125 lbs. initial gauge pressure assume the quality changes to 160° F. superheat; find η_1, η_2 and η_3 . Assume the back pressure is changed to a vacuum of 27 in. but with no change in other conditions; find η_1, η_2 and η_3 .

Problem 6.—In a Rankine cycle with incomplete expansion let the initial gauge pressure be 125 lbs., the pressure at the end of expansion 20 lbs. gauge and the back pressure is that of the atmosphere. If $x_1 = 1.0$ find the three efficiencies, η_1, η_2 and η_3 . Change the initial pressure only to 150 lbs. gauge and find the efficiencies. Change the initial quality to 160° F. superheat and find the efficiencies. Change the back pressure only to 27 in. and find the efficiencies.

Problem 7.—The following results were obtained from a test of an engine:

Size of engine 10 in. \times 14 in. (neglect rod)	
Time of test.....	.60 min.
Clearance.....	7 per cent.
Number of revolutions.....	15,000
Steam used.....	3003 lbs.
Average gauge pressure at throttle.....	112 lbs. per sq. in.
Barometric pressure.....	14.7 lbs. per sq. in.
Average quality of steam.....	0.99
Average temperature of condensate.....	135° F.
Average temperature of water leaving.....	120° F.
Average temperature of water entering.....	75° F.
Weight of condensing water.....	58,100 lbs.

Average results from indicator cards

Point of admission.....	0.0% of stroke,....	55 lbs. abs. per sq. in.
Point of cut-off.....	33.0% of stroke,....	114.7 lbs. abs. per sq. in.
Point of release.....	93.0% of stroke,....	44.7 lbs. abs. per sq. in.
Point of compression.....	20.0% of stroke,....	14.7 lbs. abs. per sq. in.
Work of admission.....		3.22 sq. in.
Work of expansion.....		3.32 sq. in.
Work of exhaust.....		- 0.70 sq. in.
Work of compression.....		- 0.46 sq. in.

Make Hirn's analysis from the above data.

Problem 8.—In the analysis above the following coordinates give the positions of the points in inches on a 4-in. card from the true zero of pressure and volume with a spring scale of 50 lbs. per inch.

Points	Volume	Pressure	Points	Volume	Pressure
1	0.28	2.48	10	4.28	0.29
2	0.78	2.44	11	3.28	0.29
3	1.28	2.36	12	2.28	0.29
4	1.60	2.28	13	1.08	0.29
5	2.28	1.60	14	0.78	0.41
6	3.28	1.19	15	0.48	0.63
7	3.78	0.94	16	0.28	1.08
8	4.02	0.88	17	0.28	1.78
9	4.18	0.60	18	0.28	2.30

Plot the card and make the T - S analysis. Find the various losses.

Problem 9.—Find the probable value of the missing quantity for the engine given in Problem 8 by the various formulæ of this chapter.

Problem 10.—If the ratio of connecting rod to crank is 6 to 1 mark the piston positions for every five-sixtieths of a revolution on the indicator card constructed from the data of Problems 7 and 8. Also find crank positions of events of stroke. Construct the Callendar-Nicolson diagram for this card and find the probable initial condensation. Express this as a percentage of the steam given in Problem 7 and compare results with those of Problems 7, 8 and 9.

Problem 11.—Using data of Problem 8 construct table and diagram used in Clayton's method. Find probable initial condensation and steam consumption. Compare this with other results.

Problem 12.—Find the real and apparent ratios of expansion of the card of problems 7 and 8. Find the diagram factor. Find the horse-power developed in Problem 7. Find the actual steam consumption.

Problem 13.—Construct a curve of total steam consumption and from it find the curve of steam per i.h.p.-hr.

Problem 14.—Find the size of a single-cylinder non-condensing engine to drive a 125-kw. generator with initial gauge pressure of 130 lbs., cut-off at 0.3 stroke and a back pressure of 2 lbs. gauge.

Problem 15.—Construct the card for Problem 14 and find the best point of compression for 10 per cent. clearance by Stumpf's method and Webb's method. Release is at 95 per cent. of stroke.

CHAPTER VI

MULTIPLE EXPANSION ENGINES

Multiple expansion, which is the use of steam in one cylinder after another, was introduced to cut down the **wastes** in steam engines. After its introduction it was seen that for structural reasons such an arrangement is of value, as it reduces the **sizes of parts** of the machine and gives a more **uniform turning moment**. The reason for the reduction in waste is the fact that there is a series of small ranges in temperature; that

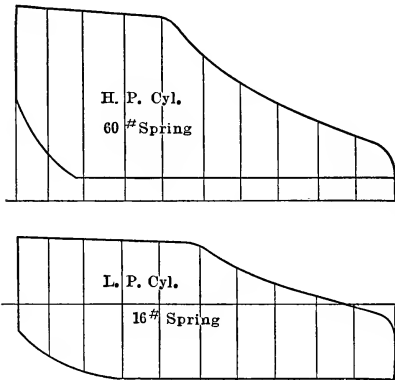

FIG. 110.—Indicator cards from high and low pressure cylinders of compound engine.

some of these ranges act on small surfaces (*i.e.*, in the smaller high-pressure cylinders), and lastly that heat abstracted by the exhaust steam from the upper stages may be of value for use in the lower stages. If the indicator cards from a two stage or compound engine are taken as shown in Fig. 110, these cards may be used as shown in the preceding chapter to study the action of the cylinder walls, to find the horse-power and to use for any purpose that cards

for simple engines are used. However, to get a fuller picture it is often desired to construct what is known as a **combined diagram**. To form this the cards of Fig. 110 from a 10 and 20 × 24 engine are divided by ordinates at regular intervals, say 10, after laying off the clearance at the end of each diagram. The extreme ends of the diagrams are placed on a new axis of volume and the base lines with their ordinates are drawn in after making the card lengths proportional to the volumes swept out by the respective pistons. In most cases since the strokes are equal these are proportional to the squares of the diameters. This increases or de-

creases all horizontal dimensions. If now a scale be assumed for pressure and the ordinates from the atmospheric pressure line are measured on the cards and reduced to this new scale, the points

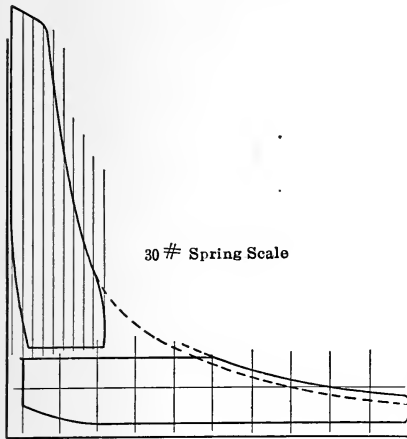

FIG. 111.—Combined cards for compound engine.

may be plotted on the new figure and the cards of Fig. 111 drawn. These are both drawn to the same scales of volume and of pressure. The diagram is known as the **combined diagram**. Since, however, the **weights of clearance steam** in each cylinder are not the same, although the working steam is equal on each, these figures do not represent diagrams for the same total weight of steam on the expansion line. For this reason the expansion line of one cylinder does not pass through

that of the other. The same is true of the compression lines. These cards show in this figure the relative amounts of work done by each cylinder and the amount lost due to the drop in pressure between the two cylinders. That these diagrams cut each other means nothing since the diagrams are not simultaneous for the same piston positions.

The first cylinder is known as the **high-pressure cylinder** and the second as the **low-pressure cylinder**. If there are three stages, known as **triple expansion**, the cylinders are known as **high pressure, intermediate pressure and low pressure**. In addition

to high- and low-pressure cylinders there are **first and second intermediate pressure cylinders** in the **quadruple expansion engine**.

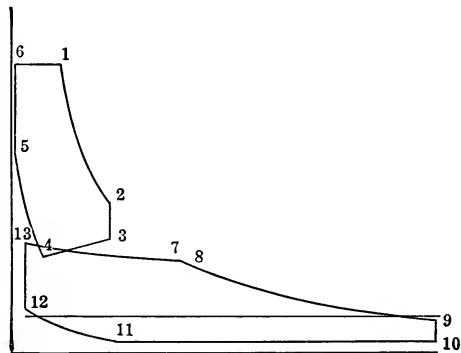

FIG. 112.—Combined cards from Woolf compound engine.

When the cylinders and cranks are so arranged that when the high-pressure cylinder is ready to discharge steam the low-pressure cylinder is ready to receive it, the engine is known as a **Woolf compound engine**, while if the discharge must be stored in a receiver before it can be used, the arrangement is known as a **receiver engine**. At times several cylinders may be used for any stage, say low, for the purpose of reducing the size. For the diagram of the Woolf engine see Fig. 112. The cut-off in the high-pressure cylinder occurs at 1 and the steam expands to 2. At this instant the steam is connected to the low-pressure cylinder in which the pressure is that shown by 12 together with the connecting pipe in which the pressure was left the same as at 8. Hence the pressure falls from 2 to 3 in the high and rises from 12 to 13 in the low and from that of 8 to that of 3 or 13 in the

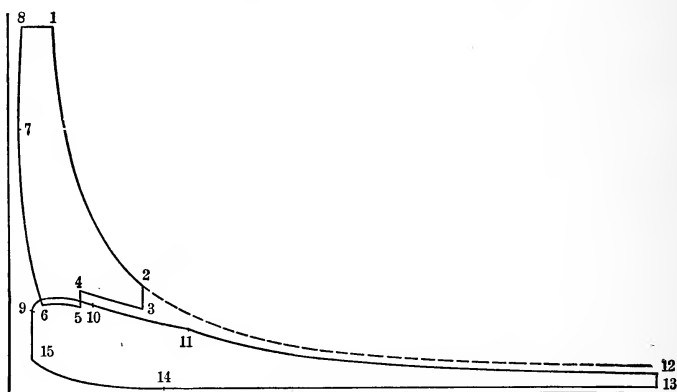

FIG. 113.—Combined cards from receiver engine.

receiver or connecting pipe. The pressure at 13 is the same as that at 3 except for a drop due to throttling in the passage through the connecting pipe. As the high pressure forces the steam out it enters the low-pressure cylinder in which there is a larger piston moving at the same speed as that of the high-pressure cylinder, and the pressure drops gradually due to this increase of volume. This finally reaches the point of compression on the high-pressure cylinder which corresponds to the point of cut-off on the low-pressure cylinder in many cases. The pressure at 7 and that at 4 are about the same. The line from 4 to 5 is the compression and from 5 to 1 there is admission. The steam in the low-pressure cylinder and connecting pipe or receiver now

expands from 7 to 8 at which point the cut-off occurs in the low-pressure cylinder. From 8 to 12 the events on the low are the same as those on a single cylinder.

The **combined cards** from a **receiver engine** are shown in Fig. 113. In this case at the end of expansion the high-pressure cylinder discharges into the receiver in which the pressure is that at 11 if cut-off in the low pressure occurs after compression on the high-pressure cylinder, while the pressure is that of 6 if this compression in the high occurs later than the cut-off in the low. In either case, the pressure in the receiver is usually lower than that at 2 and there is a drop in pressure. The low-pressure cylinder is not in a position to take steam at this point as in most cases the cranks of the engines are at right angles and for that reason the receiver is used. The amount of drop 2-3 not only depends on the pressure in the receiver but also on the **relative volume** of the receiver and the cylinder. This may be $1\frac{1}{2}$ times the volume of the high-pressure cylinder. As the piston now returns the steam is compressed into the clearance space and the receiver to the point 4. Here steam enters the low-pressure cylinder in which the pressure is 15. There is a drop from 4 to 5 in the receiver and high-pressure cylinder and a rise from 15 to 9 in the low. The line 3-4 is a rectangular hyperbola with the origin at a distance of the receiver volume from the clearance line. From 5 to 6 the small piston at the middle of its stroke is moving so much faster than the large piston at the beginning of its stroke that the volume decreases and the pressure rises at first. It then usually falls before 6 is reached, 9 agrees with 5, and 10 with 6. Cut-off on the low occurs after compression on the high but before the high pressure reaches the end of its stroke. If it did not occur sooner than this there would be a second admission of steam from the other end of the high-pressure cylinder. The other points are clearly seen.

COMPUTATION OF CARDS FOR CONSTRUCTION

To compute these various points the volumes of the two cylinders must be known, with the clearances; the volume of the receiver must be known, and finally the points of all the events of each card and the initial pressures.

Let V_r = receiver volume.

V = volume of cylinder at event represented by subscript including clearance.

p with subscript = pressure at point.

Now from the curve on Fig. 103 it is seen that $m = kp$ approximately, hence the total weight of saturated steam at any point is

$$M = mV = kpV \quad (1)$$

or the weight of steam is approximately equal to the product pV . Hence if quantities of steam of different volumes and at different pressures are connected the resultant pressure multiplied by the sum of the volumes must be equal to the sum of the individual products of pressure and volume, or

$$p_r = \frac{\Sigma pV}{\Sigma V} \quad (2)$$

With this understanding, the following equations hold:

$$p_2 = \frac{p_1 V_1}{V_2} \quad (\text{known}) \quad (3)$$

$$p_3 = \frac{p_2 V_2 + p_{11} V_r}{V_2 + V_r} \quad (p_{11} \text{ unknown}) \quad (4)$$

$$p_4 = \frac{p_3(V_3 + V_r)}{V_4 + V_r} \quad (\text{In terms of } p_{11}) \quad (5)$$

$$p_5 = p_9 = \frac{p_4(V_4 + V_r) + p_{15} V_{15}}{V_4 + V_r + V_{15}} \quad (\text{In terms of } p_{11}; \text{ since } p_{15} V_{15} \text{ is known}) \quad (6)$$

$$p_{15} V_{15} = p_{14} V_{14} \quad (7)$$

$$p_6 = \frac{p_5(V_4 + V_r + V_{15})}{V_6 + V_r + V_{10}} \quad (\text{In terms of } p_{11}) \quad (8)$$

$$p_7 = \frac{p_6 V_6}{V_7} \quad (9)$$

$$p_{11} = \frac{p_{10}(V_{10} + V_r)}{V_{11} + V_r} \quad (\text{In terms of } p_{11}; \therefore p_{11} \text{ is known}) \quad (10)$$

$$p_{12} = \frac{p_{11} V_{11}}{V_{12}} \quad (11)$$

To apply these a table is first computed for all volumes in proportional numbers if not in actual numbers, and from this table the substitution can be made in the equations above. To find the relative position of events a diagram is made with the cranks as shown in Fig. 114. The actual position could be found by using the connecting rods or if infinite rods are assumed the projections may be used. Thus if the compression is to occur at 0.1 stroke on the high-pressure cylinder, the diagram for an infinite connecting rod would be shown in Fig. 114, with a crank

$$p_{15} = 2 \times \frac{1.00}{0.2} = 10$$

$$p_6 = p_{10} = \frac{(43.2 + 0.514p_{11}) 1.56}{0.16 + 0.8 + 1.00} = 34.4 + 0.41 p_{11}$$

$$p_{11} = \frac{(34.4 + 0.41p_{11})(1.00 + 0.8)}{2.00 + 0.8} = 22.1 + 0.264 p_{11}$$

$$p_{11} = \frac{22.1}{0.736} = 30$$

$$p_{10} = p_6 = 46.7$$

$$p_5 = p_9 = 58.7$$

$$p_4 = 64.9$$

$$p_3 = 47.4$$

$$p_7 = 46.7 \times \frac{0.16}{0.06} = 125$$

$$p_{12} = 30 \times \frac{2.00}{4.20} = 14.3$$

This method could be used for triple expansion engines or for any arrangement of cylinders. The main point to remember is to reduce the equations for any unknown to terms of one unknown until at last this term occurs on both sides of the equation and the equation gives its value.

EQUIVALENT WORK DONE BY ONE CYLINDER

On looking at the cards of Figs. 111, 112 and 113 it will be seen that the total length of the combined diagram represents the volume of the low-pressure cylinder and if the intermediate lines were removed the card would appear as a single cylinder card with very early cut-off. The cylinder would be of the same size as the low-pressure cylinder. Hence it may be said that if the same initial pressure is used in a cylinder of the size of the low-pressure cylinder of a multiple expansion engine as is used in the high-pressure cylinder, and if this has the same total ratio of expansion, then it will develop the same horse-power as the multiple expansion engine.

It is well to note what differences occur. With the single cylinder the whole clearance surface of the large cylinder is subject to the full temperature range which would cause excessive condensation unless it is of the Stumpf form of cylinder. The large cylinder would be subject to full high pressure not only requiring heavy walls for the cylinder but causing the rods, pins

pansion and consequently the pressure is determined. If the cut-off is made later in the intermediate cylinder the point f would be further to the right and consequently the pressure would have to be lower. This would produce less work on the cylinder. Hence the statement is often made that increasing the cut-off of a cylinder reduces the work of that cylinder. If this is done on the high-pressure cylinder the same result follows, as the other cut-offs will be made relatively earlier by this operation and the intermediate pressure will rise.

The whole area of the combined card being the work which could be developed by the low-pressure cylinder gives a method of determining the size of the cylinder. The **size of this cylinder fixes the power** of the engine. The sizes of the other cylinders determine the relative amount of work done by them but do not affect the power of the engine.

The m.e.p. for the whole card is found by assuming p_1 , p_b , and R , the total ratio of expansion.

$$\text{m.e.p.} = f \left[\frac{p_1}{R} (1 + \log_e R) - p_b \right] = P \quad (12)$$

$$\begin{aligned} f &= \text{diagram factor} \times \text{clearance factor.} \\ &= 0.65 \text{ for naval triple.} \\ &= 0.70 \text{ for naval compound.} \\ &= 0.80 \text{ for Corliss compound and triple land.} \\ &= 0.90 \text{ for pumping engine.} \end{aligned}$$

Another form, if p_r , the pressure at the end of expansion is assumed rather than R , is

$$\text{m.e.p.} = f \left[p_r \left(1 + \log_e \frac{p_1}{p_r} \right) - p_b \right] = P \quad (13)$$

From this the size may be found by assuming $2LN$ and finding F_i .

$$\text{i.h.p.} = \frac{2PLF_iN}{33000} \quad (14)$$

Having F_i the **areas of the pistons of the other cylinders** are found from the ratios of

$$\frac{cd'}{ab} \text{ and } \frac{ef'}{ab}$$

Thus

$$F_i = F_l \frac{cd'}{ab} \quad (15)$$

$$F_h = F_l \frac{ef'}{ab} \quad (16)$$

The lengths cd' and ef' are found by obtaining the pressures p'_2 and p''_2 and drawing the figure or computing the lines cd and ef and allowing for the distances dd' and ff' .

Thus
$$cd = ab \frac{p'_2}{p_r} \tag{17}$$

$$ef = ab \frac{p''_2}{p_r} \tag{18}$$

There are four ways in which to fix the intermediate pressures :
 (a) equal works, (b) equal ratios of expansion, (c) equal temperature ranges and (d) assumed ratios.

(a) For equal work the card is divided into equal areas.

$$\text{Area card} = D_l \left[p_r \left(1 + \log_e \frac{p_1}{p_r} \right) - p_b \right] = F_t \tag{19}$$

$$\text{Area l. p. card} = D_l \left[p_r \left(1 + \log_e \frac{p'_2}{p_r} \right) - p_b \right] = F_l \tag{20}$$

$$\begin{aligned} \text{Area l. p. card + i.p. card} \\ = D_l \left[p_r \left(1 + \log_e \frac{p''_2}{p_r} \right) - p_b \right] = F_2 \end{aligned} \tag{21}$$

$$\begin{aligned} \text{Area of three lowest cards} \\ = D_l \left[p_r \left(1 + \log_e \frac{p'''_2}{p_r} \right) - p_b \right] = F_3 \end{aligned} \tag{22}$$

$$\text{For } n \text{ stages:} \quad F_l = \frac{1}{n} F_t \tag{23}$$

$$F_2 = \frac{2}{n} F_t \tag{24}$$

$$F_3 = \frac{3}{n} F_t \tag{25}$$

In each of these there is only one unknown term p_2 . Hence these pressures may be found.

$$\text{Thus } \frac{1}{n} \left[p_r \left(1 + \log_e \frac{p_1}{p_r} \right) - p_b \right] = p_r \left(1 + \log_e \frac{p'_2}{p_r} \right) - p_b \tag{26}$$

$$\log_e p'_2 = \left(\frac{1}{n} - 1 \right) \left[1 - \frac{p_b}{p_r} \right] + \frac{1}{n} \log_e \frac{p_1}{p_r} + \log_e p_r \tag{27}$$

$$\log_e p'_2 = \left(\frac{1}{n} - 1 \right) \left[1 - \frac{p_b}{p_r} \right] + \frac{1}{n} \log_e \frac{p_1}{p_r^{1-n}} \tag{28}$$

In the same manner:

$$\log_e p''_2 = \left(\frac{2}{n} - 1 \right) \left[1 - \frac{p_b}{p_r} \right] + \frac{2}{n} \log_e \frac{p_1}{p_r^{1-\frac{n}{2}}} \tag{29}$$

For the m th receiver:

$$\log_e p^{m_2} = \left(\frac{m}{n} - 1\right) \left[1 - \frac{p_b}{p_r}\right] + \frac{m}{n} \log_e \frac{p_1}{p_r^{1 - \frac{n}{m}}} \quad (30)$$

(b) For equal ratios of expansion the following method is used:

$$R = \frac{p_1}{p_r}$$

$$R = r_1 \times r_2 \times r_3 \times \dots = r^m$$

$$r = \sqrt[m]{R} \quad (31)$$

$$p'_2 = rp_r \quad (32)$$

$$p''_2 = r^2 p_r = rp'_2 \quad (33)$$

$$p_2^m = r^m p_r = rp_2^{m-1} \quad (34)$$

(c) For equal temperature ranges the temperature range between p_1 and p_b is found and this divided by the number of stages gives the range per stage. If this is added to the lowest temperature successively the various temperatures are found and from these the corresponding pressures are obtained.

$$\frac{T_1 - T_b}{m} = \Delta T \quad (35)$$

$$T'_2 = T_b + \Delta T \quad (36)$$

$$T''_2 = T_b + 2\Delta T = T'_2 + \Delta T \quad (37)$$

$$T^{m_2} = T_b + m\Delta T \quad (38)$$

(d) For assumed ratios of cylinder volumes there is no necessity of finding the intermediate pressure. The usual ratios of practice are:

Compound engines $D_h : D_l = 1 : 2$ to $1 : 7$

Triple expansion $D_h : D_i : D_l = 1 : 2.5 : 6.5$

For compound engines a ratio $1 : 4$ is quite common.

When quick response is needed to a suddenly changing load the small ratios are used; *i.e.*, the larger high-pressure cylinders are used.

As an example, suppose it is desired to construct a triple expansion engine to produce 2000 kw. from a generator at 100 r.p.m. with boiler steam at 175 lbs. gauge pressure with 80° F. superheat, with the pressure at release -5 lbs. gauge and a back pressure of 2 lbs. absolute.

$$\text{m.e.p.} = 0.90 \left[9.7 \left(1 + \log_e \frac{189.7}{9.7} \right) - 2 \right] = 33.0$$

$$\text{i.h.p.} = 2000 \times 1.6 = \frac{33.0 \times 1000 \times F_l}{33000}$$

$$F_l = 3200 \text{ sq. in.}$$

$$d = 64 \text{ in.}$$

$$2LN = 1000$$

$$L = \frac{1000}{2 \times 100} = 5 \text{ ft.} = 60 \text{ in.}$$

Intermediate pressures and volumes.

Method (a)

$$\log_e p'_2 = \left(\frac{1}{3} - 1 \right) \left[1 - \frac{2}{9.7} \right] + \log_e \left(189.7 \times 9.7^2 \right)^{\frac{1}{3}}$$

$$= -0.53 + 3.26$$

$$= 2.73$$

$$p'_2 = 15.4.$$

$$\log_e p''_2 = \left(\frac{2}{3} - 1 \right) \left[\frac{7.7}{9.7} \right] + \log_e \left(189.7 \times 9.7^{\frac{1}{2}} \right)^{\frac{2}{3}}$$

$$= -0.26 + 4.25$$

$$= 3.99$$

$$p''_2 = 52.1$$

$$F_i = F_l \frac{9.7}{15.4} = 3200 \times \frac{9.7}{15.4} = 2020; d_i = 51 \text{ in.}$$

$$F_h = 3200 \frac{9.7}{52.1} = 595; d_h = 28 \text{ in.}$$

Engine 28-51 and 64 × 60.

Method (b)

$$R = \frac{189.7}{9.7} = 19.5$$

$$r = \sqrt[3]{19.5} = 2.69$$

$$p'_2 = 2.69 \times 9.7 = 26.1$$

$$p''_2 = (2.69)^2 \times 9.7 = 70.2$$

$$d_i = 39 \text{ in.}$$

$$d_h = 24 \text{ in.}$$

Engine 24-39 and 64 × 60.

Method (c)

$$T_1 = 377.5 + 80 = 457.5$$

$$T_2 = 126.2$$

$$\Delta T = \frac{331.3}{3} = 110.4$$

$$T'_2 = 236.6; \quad p'_2 = 23.5$$

$$T''_2 = 347.0; \quad p''_2 = 129.4.$$

$$d_i = 42 \text{ in.}$$

$$d_h = 17\frac{1}{2} \text{ in.}$$

Engine $17\frac{1}{2}$ -42 and 64×60 .

Method (d)

Assume ratio of 1-2-6.

$$d_i = 45 \text{ in.}$$

$$d_h = 26 \text{ in.}$$

Engine 26-45 and 64×60 .

In the above solutions the expansion was complete in the upper two cylinders. If the diameters are made slightly smaller there will be free expansion in each cylinder.

The relative size could now be found with the clearance which varies from 10 per cent. or 15 per cent. in slide valve engines to 5 per cent. in ordinary Corliss engines and 2 per cent. in engines with the valves in the heads. The events could be assumed and the volumes of the receivers after which the cards similar to those in Fig. 113 could be computed.

The pressures of 90 to 120 used with simple expansion engines are changed in multiple expansion engines to from 150 to 225 lbs. gauge. The higher pressures are used with triple expansion engines. 150 to 175 lbs. would be used for compound engines although higher pressures are used with such. At times lower pressures are used with these two stage engines but generally lower pressures do not give sufficient expansion. The higher pressures should give higher efficiencies but the troubles from initial condensation and free exhaust exist here to a great degree. In most cases, however, neither of these effects is so prominent as with single cylinder engines and the steam consumption curves are more nearly flat, giving considerable range without much variation in steam consumption. Such steam consumption curves are valuable in any engine or turbine as they give a good efficiency over a great range.

The **back pressure** should be reduced to as low a value as

will give a gain on the entropy diagram. Owing to the free expansion in these engines there may be a condition for which an increase of vacuum means a loss. About 28 in. is sufficient for the vacuum to be carried on a multiple expansion engine.

In these engines as in the case of the simple engines, the large, slow-speed engines are those which give the highest efficiency. The larger the cylinder, the more efficient the engine.

Method (a) is the one usually employed to fix the relative size of cylinders.

JACKETING

In these engines the **effect of jacketing** is not always a source of economy except in small sizes. The gain on a triple expansion engine is probably larger than that found on a compound engine or on a simple engine due to the fact that heat added to the exhaust steam by the jacket when the moisture on the cylinder walls is vaporized is of use in the lower stages.

A number of tests have been made on large pumping engines and it has been found that the engine would consume about the same amount of total steam with or without jackets.

REHEATERS

Steam as it leaves the cylinder of an engine is likely to be quite wet and hence the moisture deposited on the walls at entrance into the next cylinder would be increased and this might lead to excessive condensation. To cut down this moisture, the receiver is equipped with a reheating steam coil containing high-pressure steam, the receiver is now called a **reheating receiver** or **reheater**. The value of the reheater lies in the fact that dry steam is carried into the cylinder. The value of this apparatus is also questioned as some engines on test show an increase of total heat when reheaters are used. Other engines show a decrease in the total heat. The heaters should contain enough heating surface and have a high enough steam temperature to completely dry the steam and to superheat it sufficiently to bring the steam to a dry condition at cut-off. If this can be done, a gain should result.

In both jackets and reheaters the apparatus should be thoroughly **drained** and the supply of steam should be taken to the apparatus alone. The steam should be hotter than the steam to be heated. The use of steam on its way to the first cylinder for

a jacket is bad as this may introduce moisture into the cylinder. The use of exhaust steam for a jacket is condemned. The supply of steam should be through pipes of ample size. This apparatus should always be air vented. Heavy **lagging** of non-conducting material has been found of value in engines in cutting down radiation.

GOVERNING

The multiple expansion engines are **governed** by changing the point of cut-off on the high-pressure cylinder alone or by changing it on each cylinder at the same time and in the same ratio.

In Fig. 116, the method of regulation by **changing the cut-off on the high-pressure cylinder** is shown while the method by

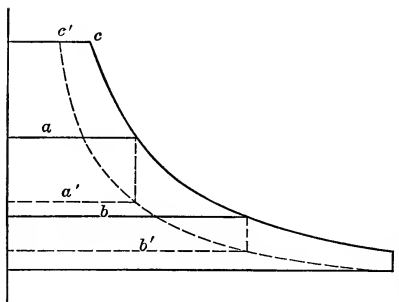

FIG. 116.—Method of governing by changing cut-off on high pressure only.

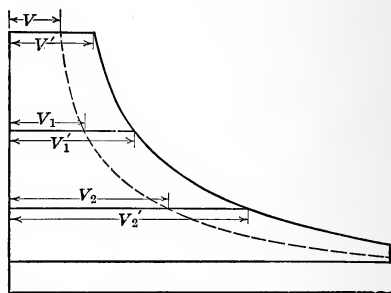

FIG. 117.—Method of governing by changing cut-off proportionately on each cylinder.

changing the cut-off on each cylinder is shown in Fig. 117. In this latter method the ratios of the V 's are all equal if the pressure in the receiver is to remain constant.

$$\frac{V}{V'} = \frac{V_1}{V'_1} = \frac{V_2}{V'_2}$$

In the first method the receiver pressure changes from a to a' and from b to b' . Before the receiver pressure can drop the work done must be represented by the curves shown in Fig. 118. In this it will be seen that the governor has reduced the area by the shaded amount and if this is enough to care for the change in load, the point of cut-off will have to gradually change. The receiver pressures gradually change to their final values and the

expansion curve takes the position shown dotted in Fig. 118; the area between the original and final curves being equal to the shaded area. Since this change does not occur at once with receivers of any size the action is sluggish. Of course this change is accomplished in ten or fifteen revolutions but it will not be as steady as that resulting from the method shown in Fig. 117. With small fluctuations either method is good. The method of Fig. 116 cuts down the work on the lower cylinders leaving the high pressure about the same while the method of Fig. 117 affects all in the same way if not by equal amounts.

Throttling would be shown in Fig. 119. In this the pressure in the receiver would change and although the total work is

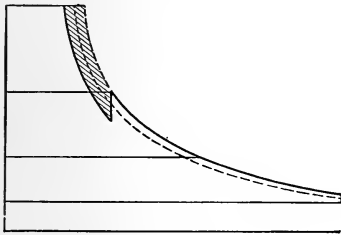

FIG. 118.—Sluggish action due to cut-off change on high-pressure cylinder only. Shaded area shows decrease of work on first stroke.

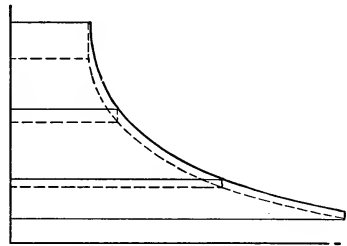

FIG. 119.—Governing by throttling.

less, the reduction is mainly on the low-pressure cylinder, as there is little change on the high. This method throws out the equality of works.

BLEEDING ENGINES OR TURBINES

The use of **low-pressure steam for heating water**, for use in warming buildings or for other technical applications is carried out in plants having high-pressure steam, by throttling the steam through a reducing pressure valve to the lower pressure. Now although throttling does not mean a loss of heat, there is the loss of available energy if by this is meant the ability to be turned into mechanical work. This may be seen by remembering that it is a difference in pressure which must exist to give ability for work in a cylinder. The production of high-pressure steam is usually more expensive than that of low pressure due to the higher temperature of the steam; hence after producing this high-

pressure steam many engineers believe that it should be brought to its low temperature by passing it through an engine or turbine where its available energy may be utilized. After reaching the desired temperature and pressure this steam may be used. If

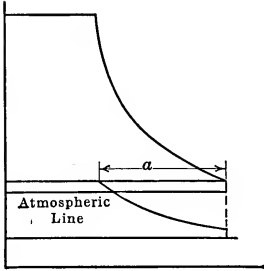

FIG. 120.—Combined cards from a compound engine with steam removed from receiver. Cylinders of equal sizes.

the engine or turbine is connected to a condenser, provision is made to take off a portion of the steam between stages where the pressure is at or near the atmospheric pressure. Were this amount constant the machines could be made to be operated with one quantity to one pressure and with another quantity to a lower pressure. The card from such an application on a compound engine is shown in Fig. 120. The volume a has been taken for use outside of the engine. The low-pressure cylinder has been assumed to be similar to the high-pressure cylinder in this case. If no steam is taken the low-pressure card becomes rectangular as shown by dotted line.

REGENERATIVE ENGINES

The preceding suggests the **regenerative steam engine** cycle in which steam is taken from the receiver to raise the feed water to that temperature before entering the boiler. Steam from one receiver brings the water to that temperature and that from the next receiver brings the water and the steam condensed from its temperature to the temperature of the next. To see the application of this suppose that it is applied to a triple expansion engine the diagram of which is shown in Fig. 121. The

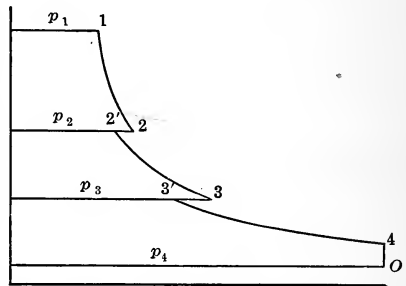

FIG. 121.—Combined cards from a regenerative triple expansion engine.

decrease in the volume of each card is due to the removal of a certain amount of steam to mix with the feed water to raise it to the temperature of the receiver. There would be two analyses of this depending on whether or not the condensed

steam from the feed heaters is pumped into the feed. Of course this should be done. The expansion is assumed adiabatic in theory and 1 lb. of steam will be assumed on the lower card. The pressures are p_1, p_2, p_3, p_4 and p_o .

Heat to raise 1 lb. of water from t_o to $t_3 = q'_3 - q'_o$

Amount of steam at quality x_3 to give this = $\frac{q'_3 - q'_o}{x_3 r_3} = M_2$

Amount of steam on second card = $1 + M_2$

Amount of steam of quality x_2 to raise $1 + M_2$ lbs. of water from t_3 to $t_2 = \frac{(1 + M_2)(q'_2 - q'_3)}{x_2 r_2} = M_1$

Amount of steam on first card = $1 + M_2 + M_1$

Heat to raise $1 + M_2 + M_1$ lbs. of water from t_2 to $t_1 = (1 + M_2 + M_1)(q'_1 - q'_2)$

Heat to vaporize $(1 + M_2 + M_1)$ lbs. = $(1 + M_1 + M_2) x_1 r_1$

Total heat from outside = $(1 + M_2 + M_1)[i_1 - q'_2] = Q_1$

Work done on cycles = $(1 + M_2 + M_1)[i_1 - i_2] + (1 + M_2)[i_1 - i_3] + 1\{i_3 - i_4\} + A(p_4 - p_o)v_4 = AW$

The i 's are found on the same adiabatic for 1 lb. of steam from one end to the other.

$$\text{Efficiency} = \frac{AW}{Q_1}$$

This is compared with efficiency for the same weight in each cylinder.

$$\text{Efficiency} = \frac{i_1 - i_4 + A(p_4 - p_o)v_4}{i_1 - q'_o} \quad (39)$$

and the saving is shown.

Let this be applied to a compound engine working between 150 lbs. absolute and 2 lbs. absolute with original dry steam and a receiver pressure of 45 lbs. absolute and a pressure at release in the low of 8 lbs. absolute.

$$i_1 = 1192.6 \qquad q'_1 = 330.0$$

$$i_2 = 1100.0 \qquad q'_2 = 243.7$$

$$i_3 = 987.0 \qquad q'_3 = 150.9$$

$$v_3 = 39.9 \qquad q'_4 = 94.2$$

$$x_2 = 0.92 \qquad r_2 = 927.5$$

$$M_2 = \frac{243.7 - 94.2}{0.92 \times 927.5} = 0.176$$

$$\text{Heat} = 1.176[1192.6 - 243.7] = 1113$$

$$\text{Work} = 1.176[1192.6 - 1100] + 1\left\{1100 - 987 + \frac{144}{778}(8 - 2)39.9\right\}$$

$$= 108.7 + 157.4 = 266.1$$

$$\text{Theoretical eff.} = \frac{266.1}{1113} = 0.236$$

$$\begin{aligned} \text{Theoretical eff. of ordinary cycle} &= \frac{[1192.6 - 987 + \frac{144}{778}(6 \times 39.9)]}{1192.6 - 94.2} \\ &= \frac{250.0}{1098.4} = 0.228 \end{aligned}$$

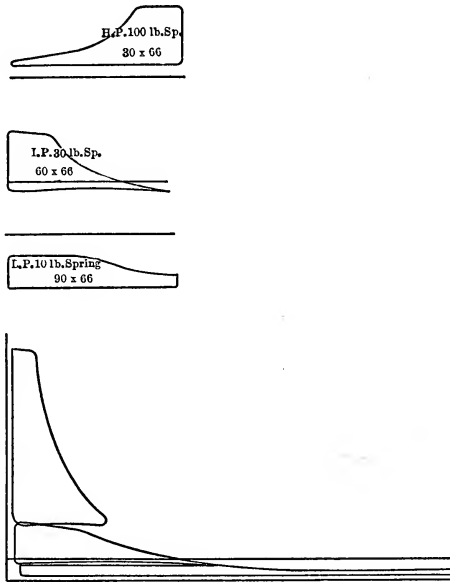

FIG. 122.—Individual and combined cards from test of pumping engine.

This means a saving of 0.8 in 22.8 or $3\frac{1}{2}$ per cent. It will be seen from the expression for the work on each cycle that the low-pressure cylinder is doing 50 per cent. more work than the high-pressure cylinder.

Data from the test of a triple expansion engine with its cards given in Fig. 122:

Size of pump.....	20,000,000 gal. per 24 hr.
Size of cylinders.	
Steam.....	30 in., 60 in. 90 in., × 66 in.
Water.....	33 in. × 66 in.
Pressures by gauge	
Steam supply.....	180.2 lbs. per sq. in.
1st Receiver.....	25.4 lbs. per sq. in.
2d Receiver.....	9.5 in. vacuum
Condenser.....	26.7 in. vacuum
Water discharge.....	86.9 lbs. per sq. in.
Barometer.....	14.86 lbs. per sq. in.
Revolution in 24 hr.....	28,989
Displacement per revolution.....	732 gal.
Temperatures.	
Return from condenser.....	113° F.
Water pumped.....	40° F.
Condensing water.....	40° F.
Water leaving condenser.....	70° F.
Outside air.....	30° F.
Quality of steam.....	0.989
Water pumped to boiler, per hour.....	9,266 lbs.
Boiler leakage, per hour.....	196 lbs.
Drip in engine room, per hour.....	135 lbs.
Steam to drip pump, per hour.....	58 lbs.
Net boiler steam, per hour.....	8,877 lbs.
Jacket drip, per hour.....	661 lbs.
1st Receiver drip, per hour.....	422 lbs.
2d Receiver drip, per hour.....	361 lbs.
Indicated horse-power steam end	
High pressure.....	332.02
Intermediate.....	269.10
Low pressure.....	260.22
	<hr/>
Total.....	861.34
Water end.....	839.8
Delivered horse-power.....	822.9
Steam per i.h.p.-hr.....	10.37 lbs.
Heat per i.h.p.-min.....	193.04 B.t.u.
Duty per 1000 lbs. dry steam.....	181,000,000

TESTING AND ANALYSIS

There are a few points which must be brought out in regard to testing multiple expansion engines.

The exhaust from these engines is not all at the temperature of

the condensed steam when reheaters or jackets are used. In such a case the drips from the jacket or reheater are at temperatures much higher. These possess the temperature corresponding to the steam pressure. Hence if M pounds of steam are used by the main engine, and m_j and m_r are the amounts used in the jackets and reheaters, the amount of heat chargeable to the engine is

$$Q_1 = (M + m_j + m_r)i_1 - Mq'_o - m_jq'_j - m_rq'_r \quad (40)$$

In this q'_j and q'_r are the heats of the liquid in the jacket and reheater.

The efficiency which has been given as

$$\eta = \frac{AW}{(M + m_j + m_r)(i - q'_o)} \quad (41)$$

is now
$$\eta = \frac{AW}{(M + m_j + m_r)i - Mq'_o - m_jq'_j - m_rq'_r} \quad (42)$$

In **Hirn's analysis for multiple expansion engines** a new device must be used to find the heat delivered to the second cylinder and discharged from the first cylinder. In analyses of multiple expansion engines it is necessary to find Q_r , the heat radiated from each cylinder. Having this for the first cylinder, the heat losses, Q_a , Q_b , and Q_d , are found by the formulæ and then Q_c is given by

$$Q_c = Q_r - (Q_a + Q_b + Q_d) \quad (43)$$

The heat exhausted from the first cylinder is

$$Q_2 = AU_4 - AU_3 + AW_c - Q_c \quad (44)$$

or
$$Q_2 = Q_1 - Q_r - A(W_a + W_b + W_c + W_d) \quad (45)$$

The heat given to the second cylinder Q' , is

$$Q'_1 = Q_2 + Q_h - Q_l \quad (46)$$

Q_h is the heat given to the steam in the reheater and Q_l is the heat lost in radiation from the reheater. This term Q_l is found by a radiation test similar to that made on the engine.

By observing the condensation from the receiver coil when no steam is passing from one cylinder to the other, the value of Q_l is found while the observations during the operation of the engine gives the term Q_h .

$$Q_h \text{ or } Q_r = M(i - q'_o) \quad (47)$$

Equation (45) furnishes the heat supplied the second stage and a similar procedure is used for the lower stages.

If a jacket is used on any cylinder, the heat supplied by the jacket is found by weighing the steam condensed. The heat is given by

$$Q_j = M(i - q') \quad (48)$$

If an engine is jacketed there is a new term in Q_r :

$$Q_r = Q_a + Q_b + Q_c + Q_d + Q_j \quad (49)$$

and for multiple expansion engines Q_c is given by

$$Q_c = Q_r - (Q_a + Q_b + Q_d + Q_j) \quad (50)$$

Then $Q_2 = Q_1 + Q_j - Q_r - A(W_a + W_b + W_c + W_d) \quad (51)$

BINARY ENGINES

Another method of utilizing the waste heat and avoiding the waste due to free expansion on account of the great volume of low-pressure steam is to use the exhaust to volatilize a liquid, such as sulphur dioxide, which has a much higher saturation pressure than steam. In this way the same limits of temperature may be utilized without passing to such low pressures as used on steam engines. Engines using two vapors are known as **Binary Engines**. In a development of this engine by Professor E. Josse of Berlin, steam from an engine was exhausted into a surface condenser in which the condensing fluid was volatile SO_2 , which by its evaporation removed heat from the steam and condensed it. The pressure of the steam was 3 lbs. per square inch. This gave a temperature of 141°F . SO_2 at 132°F . is under pressure of 132 lbs. per square inch so that the SO_2 would boil and produce a pressure of 132 lbs. absolute while condensing steam at 3 lbs. pressure. This could be used in a cylinder connected with the same shaft as the steam cylinders and aid in the driving. This cylinder exhausted into a condenser cooled by water at 50°F . in which the SO_2 condensed at a pressure of 31 lbs. absolute and a temperature of 66°F . The condensed SO_2 was pumped into the steam condenser where it was evaporated again and used.

In the steam engine Josse developed about 150 h.p. on 250 B.t.u. per horse-power minute and by using the exhaust as described above, 50 additional horse-power were developed giving 176 B.t.u. per horse-power minute.

The reason for the gain in the binary engine is found in the fact that the effect of initial condensation on a large cylinder or the effect of free expansion have been eliminated. These are practical reasons and not theoretical. The range of temperature has not been increased but the pressure and volume limits have been so changed that these engines have a high practical efficiency, η_1 .

Josse has installed the engines commercially and has found that they are valuable provided a high load factor can be had. For an intermittent load or for use at intervals the engine is too expensive.

TOPICS

Topic 1.—What are multiple expansion engines? Why were they used? Why are they of value? Explain how the combined diagram is constructed. What is the difference between the Woolf and the receiver compound engines?

Topic 2.—Sketch the combined cards for a Woolf compound engine. Write the formulæ by which the pressures at the various points may be computed. Explain why

$$\frac{p_a V_a + p_v V_v}{v_a + v_v} = p_r.$$

Topic 3.—Sketch the combined cards for a receiver compound engine. Write the formulæ by which the pressures at the various points may be computed. Explain why

$$\frac{p_a V_a + p_v V_v}{v_a + v_v} = P_r.$$

Topic 4.—Explain why it may be said that the size of the low-pressure cylinder fixes the power of a multiple expansion engine. On what does the size of the higher pressure cylinders depend? If the size of the high-pressure cylinder is changed what is the effect of this?

Topic 5.—Derive the formulæ for the total work of an n -stage engine and for the work on the low-pressure cylinder. From these find the pressure at entrance to the low-pressure cylinder.

Topic 6.—Give the method of finding the intermediate pressures for equal ratios of expansion, equal temperature ranges and given ratios of volume. Knowing the pressures, show how the volumes of the various cylinders are found assuming (a) complete expansion and (b) some free expansion. What is the reason for assuming receivers of infinite capacity?

Topic 7.—Why is a 28-in. vacuum a limit for vacuum in steam-engine operation? What is the effect of jackets? Reheating? Explain what happens when the cut-off is made later on any cylinder and the reason for this effect.

Topic 8.—Discuss with diagrams the various methods of governing multiple expansion engines and show which is the better form.

Topic 9.—Explain what is meant by bleeding engines or turbines and why this is of value. Explain the action of the regenerative engine. Give the expressions for the various amounts of heat and work and derive the expression for efficiency.

Topic 10.—Derive the expression for the heat delivered to one of the lower stages of a multiple expansion engine (Q'_1 or Q_2 of Hirn's analysis). Show what effects jackets or reheaters have on this formula. What heat is chargeable to an engine when the drips from the jacket and receivers may be sent back to the feed? What is a binary engine?

PROBLEMS

Problem 1.—Find the pressures at the corners and events of the stroke for a compound engine, 8 in. and 18 in. \times 24 in.—80 r.p.m., with a receiver of volume equal to twice the volume of the high-pressure cylinder and with 8 per cent. clearance on the high-pressure cylinder and 4 per cent. on the low. Initial gauge pressure is 125 lbs. and the back pressure is 2 lbs. absolute. Cut-off is 25 per cent. and compression is at 20 per cent. of the stroke from the end. Cranks at right angles.

Problem 2.—Construct the combined cards for Problem 1 to scales of 1 in. = 30 lbs. and 1 in. = 0.435 cu. ft. Find the m.e.p. of each card. Construct the h.p. card to scales of 1 in. = 60 lbs. and 1 in. = 0.1745 cu. ft. and the l.p. card to scales of 1 in. = 20 lbs. and 1 in. = 0.884 cu. ft. Find the scale of B.t.u. per square inch of area of card, and of ft.-lbs. per square inch of card. Find the h.p. of the engine.

Problem 3.—Find the equivalent m.e.p. to be expected in Problem 1 if the complete ratio of expansion is 10. What is the size of the low-pressure cylinder to develop 350 i.h.p.?

Problem 4.—Find the size of the low-pressure cylinder of a compound Corliss engine to drive a 2000-kw. generator. The initial pressure is 160 lbs. gauge, the back pressure is 3 lbs. absolute, and the pressure at end of expansion in the low-pressure cylinder is -4 lbs. gauge. Find the size of the high-pressure cylinder by four methods.

Problem 5.—Find the receiver pressures for a triple expansion engine operating between 175 lbs. gauge and 2 lbs. absolute, with a complete ratio of expansion of 22.

Problem 6.—Construct a p - v diagram for Problem 5 with infinite receiver and no clearance and compression. Construct the T - S diagram for the same cards and show whether or not it would pay to reduce the back pressure to 1 lb. absolute.

Problem 7.—Find the sizes of cylinders to be used with a compound engine developing 1000 h.p. if the steam consumption of the engine is 15 lbs. per 1 h.p.-hr. when 30 per cent. of the steam is removed from the receiver and the engines develop equal works. The limits of pressure are 150 lbs. gauge and 3 lbs. absolute.

Problem 8.—Find the thermal efficiency of a triple expansion regenerative engine with gauge pressures as follows: Initial high, 170 lbs.; first receiver, 65 lbs.; second receiver, 5 lbs.; end of expansion, -8 lbs.; back pressure, -12 lbs.

Problem 9.—Design a cylinder to deliver 120 i.h.p. at 100 r.p.m. with $p_1 = 130$ lbs. gauge, $p_v = 3$ lbs. gauge, $r = 5$. Find the probable x at cut-off. Find the probable steam consumption. Find the pressure of SO_2 evaporated by the heat of the exhaust. Find the back pressure in an engine working with this SO_2 if the condensing water is 70°F . Sketch a card for the SO_2 cylinder. Find the volume of SO_2 vapor per minute at release and from this find the horse-power of the SO_2 cylinder and its size at 100 r.p.m. What is the thermal efficiency of the combined engine? Δt for heat transmission is 15°F .

CHAPTER VII

STEAM NOZZLES, INJECTORS, STEAM TURBINES

NOZZLES

In Chapter I the formula for the velocity of discharge of any fluid through a passage from pressure p_1 to pressure p_2 was derived. This gave

$$w_2 = \sqrt{2gJ(i_1 - i_2)} = 223.7\sqrt{i_1 - i_2} \quad (1)$$

i_1 and i_2 are the heat contents at the two pressures regardless of whether or not there is internal friction but dependent only on the fact that there is no external heat transfer. It was pointed out that i_2 for any pressure was difficult to find if there was internal friction and hence the ordinary method was to find the value of i_2 on a reversible adiabatic (which means no friction) through p_1 i_1 , and to subtract from the heat ($i_1 - i_2$), which should have been transformed into kinetic energy, the amount utilized in friction. This gives the amount remaining for change in kinetic energy. If $y(i_1 - i_2)$ is the amount of energy used in internal friction against the sides of the passage and between the particles of the fluid, the amount left for the **change of kinetic energy** is

$$(i_1 - i_2)(1 - y) \quad (2)$$

This quantity represents the change in kinetic energy and gives

$$w_2 = 223.7\sqrt{(i_1 - i_2)(1 - y)} \quad (3)$$

when w_1 is so small that $\frac{w_1^2}{2g}$ may be neglected or

$$w_2 = 223.7\sqrt{(i_1 - i_2)(1 - y) + \frac{Aw_1^2}{2g}} \quad (4)$$

when w_1 is appreciable. If w_1 is 200 ft. per second it is inappreciable as $\frac{Aw_1^2}{2g}$ is 0.8 while the first term of the bracket may be from 50 to 100 or even 250 B.t.u. The importance of this term is determined by the conditions of any problem.

The value of y is determined by experiment. w_2 is measured by the reaction of the jet and weight of the steam or by a pitot tube and from this measured value of w_2 , the value of y is computed. By measuring the quality of the steam actually present at 2 and comparing it with that of adiabatic expansion the value of y may be found. In most cases y will vary from 0.10 to 0.15 for long nozzles with large angles of divergence or for length of 10 diameters for small angles of divergence to 0.06 or 0.08 for shorter tubes. It seems that with nozzles the coefficient decreases with the increase of pressure. With orifices in plates the value of this y may be 15 per cent.

Suppose that the pressure drop is uniform along a tube and that frictional loss is zero. If the velocity at any point be computed by

$$w_x = 223.7\sqrt{(i_1 - i_x)} \quad (5)$$

and 1 lb. of steam is assumed to be passing per second the area may be computed by

$$F_x = \frac{MV_x}{w_x} = \frac{Mxv''_x}{w_x} = \frac{\pi d_x^2}{4} \quad (6)$$

The values at different points for the above assumptions are tabulated below.

NOZZLE DATA

Pressure absolute	Quality	Heat content	Specific volume	Velocity	Area, sq. in.	Diam., meters
149.1	0.4° sup.	1193.3	3.04
124.4	0.987	1178.3	3.55	865	0.592	0.87
100.2	0.972	1161.0	4.30	1270	0.487	0.79
75.4	0.953	1138.8	5.51	1640	0.484	0.78
50.0	0.929	1108.1	7.91	2060	0.554	0.84
24.97	0.894	1059.3	14.58	2590	0.810	1.02
14.99	0.872	1026.0	22.91	2890	1.140	1.20
4.97	0.830	959.9	61.20	3410	2.580	1.81

The diagram of Fig. 123 will be obtained, in which velocity, specific volume, area, and radius are plotted. It is to be remembered that in this figure the pressure drop has been made uniform. The values of i_1 and i_2 were found in the same entropy column and $x_x v''_x$ was found in that column or computed from

the value of x . It will be seen that the required area reaches a minimum section and then increases. This is due to the fact that the specific volume curve does not increase as rapidly as the velocity until the **critical point** of discharge is reached and after this the more rapid increase of specific volume makes it necessary

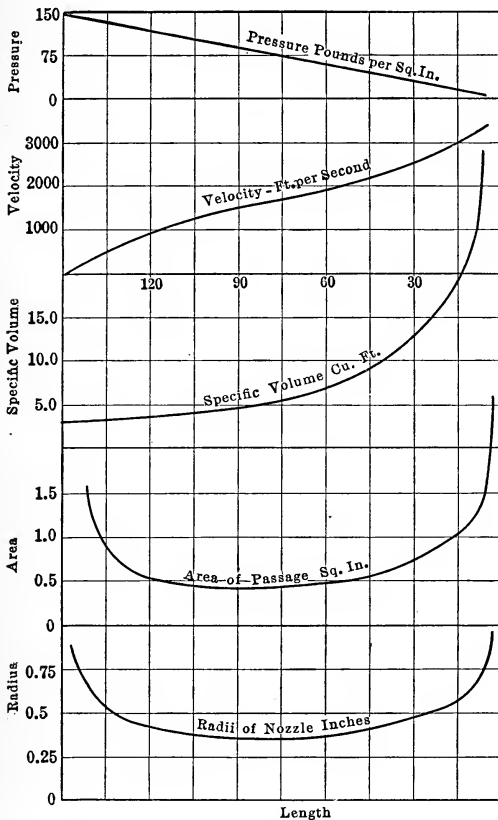

FIG. 123.—Curves of velocity, volume, area and diameter for nozzle assuming uniform pressure drop.

to increase the area. This critical point is at the pressure point

$$p_t = \left(\frac{2}{n+1}\right)^{\frac{n}{n-1}} p_1 = 0.57 p_1 \text{ for steam} \quad (7)$$

when

$$n = 1.135.$$

Whenever p_2 is less than this critical value there must be a minimum section in the tube. Such a tube is spoken of as a

nozzle and the small section is known as the **throat** and the large end is known as the **mouth**. On account of the high pressure available at the entrance to a nozzle the section from the entrance to the throat is made very short. The length of this is usually made about equal to one or two times the diameter of the throat.

A nozzle may be assumed of the section shown in Fig. 124, and the areas at various points are found and plotted. At various assumed pressures the velocity is determined and then the area to carry 1 lb. of steam is computed by the formulæ:

$$w_2 = 223.7\sqrt{i_1 - i_2} \quad (1)$$

$$F_2 = \frac{x_2 v''_2}{w_2} \quad (6)$$

The position on the curve of area for this value will fix the position of the assumed pressure. Following this for the various points the curve of pressure is obtained. The following table gives the computation for the curve, using Peabody's Entropy Table for entropy 1.56 and running from 160.8 to 14.7 lbs. pressure.

Pressure	160.8	121.1	90.9	50.0	30.35	20.02	14.7	10.17
i_1	1191.2	1191.2	1191.2	1191.2	1191.2	1191.2	1191.2	1191.2
i_2	1191.2	1168.1	1145.4	1100.7	1065.5	1037.7	1018.0	995.2
$i_1 - i_2$	0	23.1	45.8	90.5	125.7	153.5	173.2	196.0
w_2	0	1071.0	1510.0	2120.0	2500.0	2780.0	2940.0	3130.0
$x_2 v''_2$	2.811	3.601	4.63	7.84	12.18	17.60	23.13	32.08
Area $\div 10^3$	∞	3.36	3.06	3.70	4.87	6.12	7.87	10.2

At 0.57 of 160.8 or 91.7 lbs. the area is 0.00306 sq. ft. By Napier's formula this area would have been

$$F = \frac{70 \times 1}{160.8 \times 144} = 0.00302 \text{ sq. ft.}$$

a result practically the same as that in the table above. In drawing the nozzle of Fig. 124 the area at the end has been made 0.00985 sq. ft. which is larger than 0.00787 sq. ft. required at 14.7 lbs. pressure. This is known as **overexpansion** and the steam will expand to below the pressure at the end and be brought up again as shown in the figure. It means a loss in efficiency. This effect is greater than the loss due to **underexpansion** as will be

seen later. The reverse curve near the throat indicates that the distance from entrance to **throat** or minimum section is too long. A shorter length giving the steeper curve would be better.

If now friction be assumed and the areas be found for different pressures by the formulæ:

$$w_2 = 223.7\sqrt{(i_1 - i_2)(1 - y)} \tag{4}$$

$$F_2 = \frac{x'_2 v''_2}{w_2} \tag{6}$$

the curve of pressure drop with friction may be had for any given form of nozzle in the same manner as that used above. In formula (6) the value of $x'_2 v''_2$ is not found in the same entropy

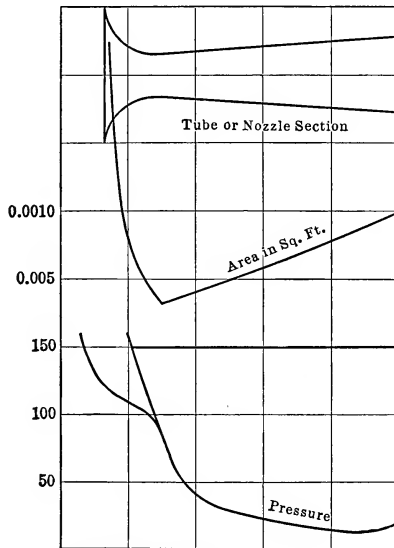

FIG. 124.—Pressure curve of nozzle obtained from velocities and areas.

column or line as that on which i_1 was found because in this case the heat content at discharge is i_2 of the isentropic line for the pressure p_2 plus the friction $y(i_1 - i_2)$. If curves for various values of y are computed and these curves are compared with the actual pressure at various points, the probable values of y may be found.

Stodola has explored the different points of a nozzle by an **exploring tube** introduced along the axis. This tube was closed at the inner end and connected to a pressure gauge at the outer

end. Holes were bored into this around the circumference at one point in the length. In place of being normal to the tube or at right angles to the axis they were inclined at 45° . There were two tubes, one with the holes inclined in the direction of flow

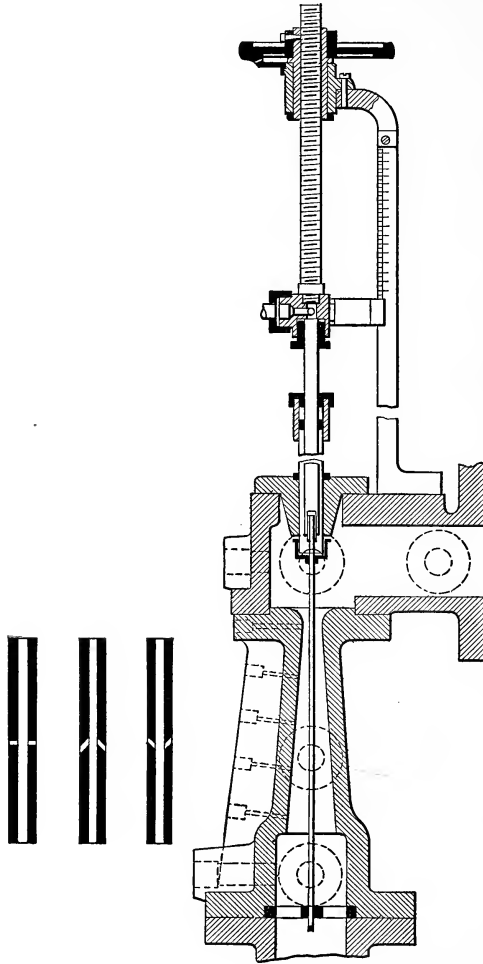

FIG. 125.—Stodola's apparatus for exploring nozzles.

and one with them inclined against the direction of flow. The readings of these varied, due to the impact of the steam increasing the pressure in one and decreasing it in the other. The mean value was used. In addition normal holes were introduced into

the side wall of one tube as shown. The pressures at the large end of the nozzle showed that for this part the curve of the value of $y = 0.10$ agreed closely with the actual curve although there was a slight increase in y as the end was reached.

Stodola found in this experiment that the pressures at the wall of the nozzle were practically the same as those at the center of the nozzle showing that with the conical nozzle there was pressure exerted on the wall confining the steam. If there were no wall present as in the case of discharge from a hole in a plate the steam would be forced outward and would follow a curved path,

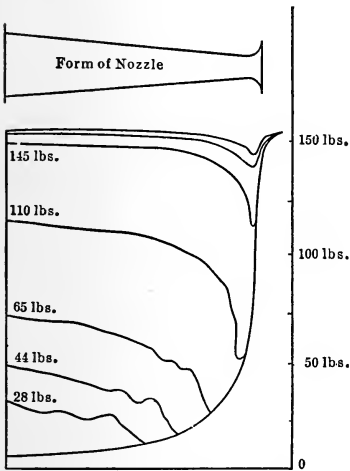

FIG. 126.—Stodola's exploration curves for nozzles.

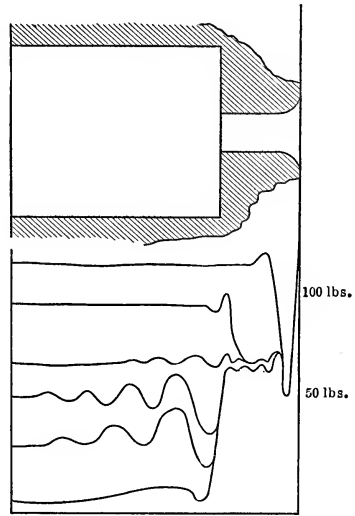

FIG. 127.—Stodola's exploration curves for orifices.

the centrifugal force exerting the necessary radial pressure to allow the steam to have an acceleration axially. This centrifugal force is only another way of expressing the inertia of the steam against radial acceleration.

If a valve is put in the pipe line beyond the nozzle, the pressure of the discharge region may be raised, and the curve found by the exploring tube shows what may happen in over expansion. Curves obtained by Stodola are shown in Fig. 126.

The waves set up at low pressures are due probably to acoustic vibrations which are so dampened by friction as to be eliminated in a short time. This is due to the fact that the velocity at

the critical pressure of the throat corresponds to the velocity of sound. This velocity of course depends on the pressure and temperature of the substance. Stodola points out that this is an illustration of Riemann's Theory of Steam Shock.

If an investigation by the exploring tube is made on a hole with a rounded entrance, known as an orifice, shown in Fig. 127, curves of somewhat similar forms are found and it will be noted that the pressure in the plane of the orifice is practically constant although it reaches a lower value beyond the face of the orifice. With a sharp-edged orifice the same observations were made although here the pressure at the outer plane of the orifice seemed to be the critical pressure. The crossing of the pressure lines at the mouth of the orifice means that the velocity at this point is the same whatever be the outer pressure, hence the quantity discharged will be the same whatever the lower pressure is, pro-

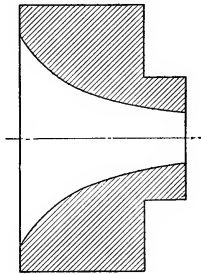

FIG. 128.—Mouthpiece or orifice.

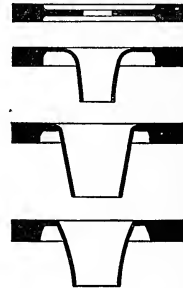

FIG. 129.—Rateau's orifices.

vided it is less than the critical pressure. Above this the line of pressure at the crossing of the plane of the orifice is greater and varies with the pressure p_2 ; the velocity in the tube is less than before. The great drop in pressure in this figure shows that the axial distance to the point of critical pressure may be very short and hence the arrangement of the nozzle in Fig. 124 was possible. It could have been made shorter. The existence of this throat demands a greater total pressure drop to the end than the amount to bring the pressure to the critical point. Hence a nozzle of the form of Fig. 124 would mean excessive overexpansion if the pressure p_2 were not below the critical pressure, as shown in Fig. 126 with a high back pressure. This would mean shock and resultant loss. In the case of a drop in pressure to a point above the critical pressure, the expansion part of the

nozzle is omitted giving the orifice of Fig. 128. On account of the pressure not reaching the critical point in certain cases it may be well to stop the curves at points earlier than the section with the parallel elements. This would give the forms suggested by Rateau, shown in Fig. 129. These are known as **orifices or converging nozzles**.

In these, the converging portion reduces the steam pressure to a point above the critical pressure. Rateau showed that the coefficient of discharge of these nozzles varied from 0.94 for a small pressure drop to unity at the critical point where $p_2 = 0.57 p_1$. For the thin orifice shown in the figure the coefficient of discharge was 0.82 at its critical point. This means that in designing nozzles the first step is to find the relation between the pressure p_2 and p_1 . If p_2 is greater than $0.57 p_1$, the nozzle is of the form shown in Fig. 129. That is, it is an **orifice or mouthpiece**. If p_2 is less than $0.57 p_1$ there will be a minimum section or **throat** and there is a **diverging part**, best spoken of as a **nozzle**.

The velocity and area are computed for the throat of the orifice or the throat and mouth of the nozzle. The steps will be best illustrated by two problems.

Suppose a nozzle is to be designed to discharge 10 lbs. of steam per second from 160.8 lbs. absolute pressure and quality 0.9966 into a vacuum of 20". This corresponds to 4.91 lbs. absolute. The areas are required.

$$p_2 < 0.57 p_1 \text{ or } 91.66 \text{ lbs.}$$

Hence there is a **throat** as well as a **mouth**.

In figuring the velocity at the throat, the length of this is so short for the drop in pressure that the friction is negligible while for the main length of the diverging portion there must be a value of y as mentioned on p. 266. The y for the problem considered with a long tube and large drop is 0.15. For a drop of a little less than this from the critical pressure the value of y would be about 0.075 if there were a short diverging portion to the nozzle.

$$w_t = 223.7 \sqrt{(1191.2 - 1146.0)} = 1501 \text{ ft. per sec.}$$

$$w_m = 223.7 \sqrt{(1191.2 - 953.1)0.85} = 3175 \text{ ft. per sec.}$$

$$v_t = 4.60$$

v_m is found on the line for 4.91 lbs. pressure but at a value of i_m equal to $953.1 + 0.15 (238.1)$ or 988.8. This is found to be 64.0 at $s = 1.617$.

$$F_t = \frac{10 \times 4.60}{1501} = 0.031 \text{ sq. ft.}$$

$$F_m = \frac{10 \times 64.0}{3175} = 0.202 \text{ sq. ft.}$$

Moyer states that F_m may be found from the formula

$$F_2 = F_1 \left[0.172 \frac{p_1}{p_2} + 0.70 \right] \quad (8)$$

Applying this

$$F_2 = 0.031 \left[0.172 \frac{160.8}{4.91} + 0.70 \right] = 0.195 \text{ sq. ft.}$$

This rule would therefore make the nozzle with slight under-expansion and the effect of this would be to reduce the velocity by the percentage shown by curve of Fig. 130 given by Moyer in his Steam Turbines. This figure shows that the effect of under-

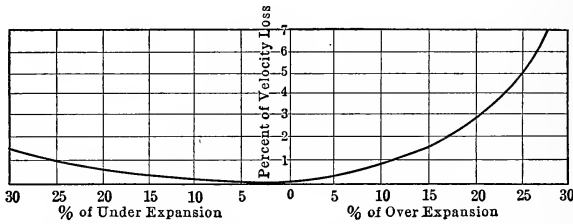

Fig. 130.—Moyer's curves showing loss due to variation in area of mouth.

expansion is less than that of overexpansion. In the problem above the amount of under-expansion by this simple rule is

$$\frac{202 - 195}{202} \text{ or } 3\frac{1}{2} \text{ per cent.}$$

The effect of this is to produce practically no change in the computed velocity.

The **length of the nozzles** is usually four or five times the diameter of the throat regardless of the amount of flare. If however the flare is over 6 deg. it would be well to make the divergent part a curve so as to support the steam pressure and accelerate the velocity. With a great flare there is no support for the steam pressure and a lower velocity results.

If the pressure p_2 is 121.1 lbs. absolute, the above computations show that this is above the critical pressure and the mouthpiece

is to be of the orifice or converging nozzle form. In this case the smallest section is at the end. If the length of this orifice is made $3d_2$ it might be well to assume a friction factor of 4 or 5 per cent. giving:

$$w_2 = 223.7\sqrt{(1191.1 - 1168.1)0.96} = 1050 \text{ ft. per sec.}$$

$$v \text{ for 121.1 lb. and } i = (1168.1 + 0.92) = 1169 \text{ is } 3.605$$

$$F_2 = \frac{10 \times 3.605}{1050} = 0.0343 \text{ sq. ft.}$$

In figuring the discharge from a nozzle or orifice when p_2 is less than $0.57p_1$ the method is to compute the discharge through the smallest area as if the critical velocity existed at that point, the velocity being computed for the drop to the critical pressure and the volume taken for that point. This method is used regardless of how much less p_2 is than $0.57p_1$. All that is meant is that the pressure at this small section is the critical pressure. This is always true for orifices while for nozzles a value of p_2 different from the one for which F_2 was designed will cause a change in velocity due to the effect of under- or over-expansion, although the weight discharged will remain constant.

INJECTORS

The first application of the discharge from nozzles is to the **injector**. This machine was invented by Henri Jacques Giffard in 1858 although the same principle had been applied by others for the raising of water by jets. Giffard's injector was introduced into various countries and through changes suggested by its application it was improved by a number of inventors. One of the modern forms of injectors is shown in Fig. 131. This is the **Seller's Improved Self-acting Injector**. Steam enters at *A* and to start the apparatus the **handle B** is drawn back a slight distance so that steam may enter the **annular space C**, the **plug D** preventing any entrance at the center. The **combining tube E** has openings *F* and *G* leading into the space *H* which is connected to the atmosphere by the valve *I* which may be held down by the **cam J**. Steam rushing through the small space at the end of *C* produces a high velocity and, due to the fact that the space *H* is at atmospheric pressure since the valve *I* opens to the atmosphere, the pressure at the end of *C* may be below that of the atmosphere due to the over-expansion. This together with

the entrainment of air by the steam jet gradually sucks the air from *K* producing a vacuum in this space, thus drawing water into the chamber. This water meets the steam issuing from *C*, and entering the tube *E* the water passes through the openings into *H* and finally overflows into the atmosphere as the cam *J* is raised. When water appears at *L* the handle *B* is drawn back, and steam entering the center imparts such a velocity to the water that when the velocity head is changed into pressure head by the diverging **delivery tube** *M* there is sufficient pressure to move the **check valve** *N* and allow the water to enter the boiler feed pipe *O*.

The function of the **steam nozzle** *C* is to lift the water to the injector while that of the **steam nozzle** *P* is to give sufficient steam

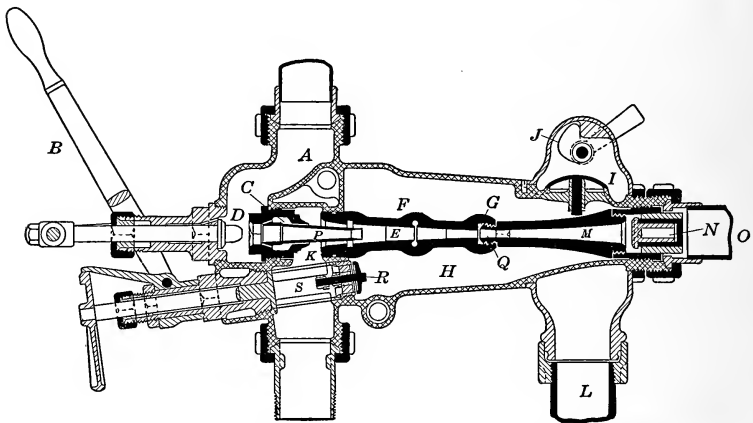

FIG. 131.—Seller's improved self-acting injector.

to mix with this water in the **combining tube** *E* so that a high velocity will occur at the **throat** *Q* where the steam is completely mixed with the water. The function of the **diverging delivery tube** is to reduce this high velocity and change this kinetic energy into pressure or potential energy. The **valve** *R* opening inward is used to allow extra water to enter *H* and so mix with the steam through *F* and *G* when the pressure in the combining tube is less than atmospheric pressure, due to a lack of water at *K*, as the plug valve *S* may not be opened sufficiently. An excess pressure in *H* caused by too much water for the steam is shown by a slight leakage at the **overflow** *L*. Thus the tube *C* will **restart** the injector and the valves *R* and *I* care for a deficiency

or excess of water which if not taken account of might cause a break in the proper action of the injector. For these reasons this is known as a **restarting self-acting injector**.

The important parts of the injector are the **steam nozzle**, the **combining tube** and the **delivery tube**. The forms of these have been the result of much experimentation. The steam nozzle will be discussed first.

Certain experiments are described by Kneass in his excellent treatise, "Practice and Theory of the Injector." One of the first things he describes on the steam nozzle is a set of photographs of their differ-

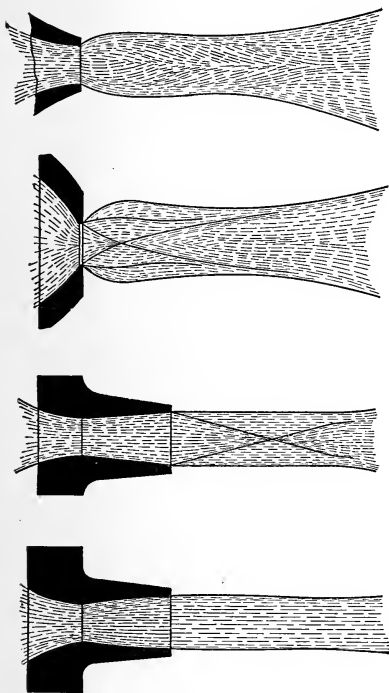

FIG. 132.—Discharge from nozzles showing action of steam, according to Kneass.

ences of their differ-

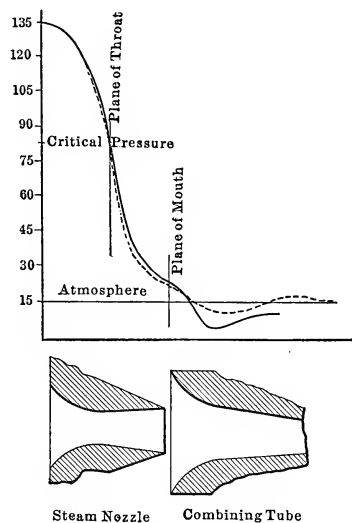

FIG. 133.—Exploration curve of Kneass.

ent forms. In the first one, the discharge from a **converging orifice** shows a sudden enlargement at the face and considerable disturbance, although this is not so great as that in the discharge from a **diaphragm** in a mouthpiece. In this there are a great number of cross currents.

The disturbance in the straight taper is not so extensive and in the discharge from the curved divergent nozzle it is practically

eliminated. The enlargement in the first two jets is due to pressure which still exists in the steam while in the last two cases this pressure has been utilized in driving the steam forward so that by the time the end of the nozzle is reached the pressure has been utilized. These indicate the form best suited for the purpose. To study what takes place in the injector he then explored the center of a nozzle and combining tube in the manner described before and obtained the pressure curve shown in Fig. 133. In this it is seen that the converging part is rather longer than has been described but the critical pressure is seen to occur at the throat. It will be observed that the end of the orifice is reached before the pressure is reduced to atmospheric pressure but this continues to fall to a lower point and in the combining tube there is a strong vacuum, which is gradually decreased, reaching atmospheric pressure before the throat of the delivery tube is reached. With no water present the steam pressure, marked by the dotted line, shows a drop below atmospheric pressure and then a rise. These two curves show that the condensing effect of the water is felt but this does not seem to change the pressure curve within the steam nozzle as the curves agree almost exactly.

STEAM NOZZLE VELOCITY

The form of steam nozzle usually employed is one with a converging part followed by a conical diverging part. The areas of the throat should be computed to care for the necessary steam and the mouth should be figured for atmospheric pressure but in order to find the amount of steam for a given amount of water the velocity of the steam jet in the combining tube is needed and for this the pressure is assumed to be 4 lbs. absolute or a vacuum of 22 in. The formulæ for the velocities at these points would be

$$w_t = 223.7\sqrt{i_1 - i_t} \quad (9)$$

$$w_m = 223.7\sqrt{(i_1 - i_{atm})(1 - 0.10)} \quad (10)$$

$$w_c = 223.7\sqrt{(i_1 - i_4)(1 - 0.10)} \quad (11)$$

i_{atm} = heat content at atmospheric pressure on same line as i_1

i_4 = heat content at 4 lbs. absolute pressure on same line as i_1

WATER VELOCITIES

The water enters the combining tube under the absolute pressure in the suction tank minus the lift, friction head, and

the pressure in the combining tube. The friction head is equal to a complex quantity due to the sudden bends in the path, the sudden changes in section and the friction on the sides. If it is assumed equal to twice the velocity head, the following equation is true:

$$\frac{w_w^2}{2g}(1 + 2) = 2.30(p_1 - p_c) + 34.0 - h_l$$

From this

$$w_w = \sqrt{2g \frac{1}{3} [2.3(p_1 - p_c) + 34.0 - h_l]} \quad (12)$$

p_1 = pressure in suction tank above atmosphere in pounds per square inch

p_c = absolute pressure in combining tube taken as 4 lbs. per square inch

h_l = lift in feet

34 = feet head equivalent to atmosphere.

Now the mixture of water and condensed steam in the combining tube must have sufficient velocity to produce a pressure equal to the boiler pressure when reduced to a low velocity of about 5 ft. per second. If w_m is the velocity of the mixture in the combining tube and w_b , that on entering the boiler, the formula for this velocity would be derived from the **Bernoulli equation**.

$$\frac{w_m^2}{2g} + \frac{p_c 144}{m_c} = \frac{w_b^2}{2g} + \frac{p_b 144}{m_b} + \text{losses}$$

Neglecting the losses

$$w_m = \sqrt{2g \left[\left(\frac{p_b}{m_b} - \frac{p_c}{m_c} \right) 144 \right] + w_b^2} \quad (13)$$

p_b = absolute boiler pressure in pounds per square inch

p_c = absolute pressure in combining tube in pounds per square inch

m_b = weight of 1 cu. ft. mixture at boiler entrance

m_c = weight of 1 cu. ft. mixture in combining tube

w_b = velocity into boilers, for instance 4 ft. per second.

By experiment Kneass found that the weight of 1 cu. ft. of mixture in the combining tube is about 80 per cent. of the weight of water at the temperature of the mixture. This decrease in density is due to the presence of air and steam in the mixture.

$$m_c = 0.80 \times m_t \quad (14)$$

m_t = weight of water per cubic foot at t° F.

= 60 lb. for first approximation

m_b is taken as equal to m_t .

THEORY OF THE INJECTOR

Now from the above equations (11), (12) and (13) the equation for the operation of the injector is obtained. The **underlying principle** of the injector is that of the **impact of bodies**: The sum of the various momenta before impact is equal to the momentum after impact. In the impact of the steam and water the action is in many directions among the various particles of condensed steam and water so that the momentum after mixture is not equal to the sum of the individual momenta. Experiment shows that it is about six-tenths of the sum or less. An average value of 0.5 will be used. If z lbs. of water are assumed to be lifted by 1 lb. of steam the following **momentum equation** holds:

$$0.5[w_c + zw_w] = (1 + z)w_m \quad (15)$$

This is the fundamental equation of action of the injector. Steam on account of its small density and on account of heat transfer attains a high velocity from the nozzle and after this it is condensed into a more dense substance, water, moving at the same velocity. This water may now be allowed to impinge on other water moving at a much slower velocity and even after the high-speed jet has mixed with eight or ten times its weight of slow moving water, the velocity resulting from the impact is sufficient to produce a pressure great enough to force the mixture into the boiler. This will be easily understood when it is realized that the steam would issue from a boiler with a velocity of 3200 ft. per second while water on account of its greater density would issue from the same boiler pressure with a velocity of 140 ft. per second.

HEAT EQUATION OF THE INJECTOR

There is now enough data for the computation of z since w_c , w_w and w_m can all be computed for given conditions. There is one quantity which has been assumed and that is m_t which was made equal to 60 lbs. This had to be assumed for the first approximation. After z is found the temperature of the mixture can be found by the equating of the energy before mixture to that after mixture.

$$i_1 + z\left(q'_w + \frac{Aw_w^2}{2g}\right) = (1 + z)\left(q'_m + \frac{Aw_m^2}{2g}\right) + \text{losses} \quad (16)$$

The energy to be accounted for in each pound of steam is i_1 before it has acquired any velocity. It must be the same after it has attained its velocity since no heat has been added from the outside. The energy in the water is that due to temperature plus the kinetic energy and the same is true for the discharge. These energies are figured above water at 32° F. as a datum plane. The terms representing the kinetic energy are so small that they may be neglected, giving the energy equation

$$i_1 + zq'_w = (1 + z)q'_m \quad (16a)$$

From (16) q'_m is found and the temperature corresponding enables one to find the weight of 1 cu. ft. of water. If this differs much from 60 lbs., the value of w_m must be recomputed and then, a new value of z . Of course the value of 0.8 for the density of the mixture is a variable and is not absolutely known in design so that a slight variation from 60 need not require recalculation.

STEAM WEIGHT

Having z the quantity of steam for a given weight M per hour of boiler feed can be found. Here M represents the weight of water taken from the suction per hour.

$$\frac{M}{3600z} = \text{weight of steam per sec.}$$

STEAM NOZZLE

Knowing the weight of steam per second, the **area at the throat and mouth** of the steam nozzle can be found from the formula.

$$F = \frac{Mv}{w} \quad (5)$$

Having the areas of the nozzle at the various points the length is found by making it taper to the proper area by a taper of 1 in 6.

COMBINING TUBE

The **combining tube** is to be designed in the next step. The form of this tube is mainly the result of experiment. The water must be sustained as it is struck by the steam and condensed steam. The form is a gradually converging tube which is made of a length of about 18 or 20 times the diameter at the **throat** of the **delivery tube**. The end should be slightly rounded and

the annular area should be equal to that required to admit the water with a velocity due to the pressure at this point which would probably be about one-half the velocity of the water at the point of lowest pressure.

DELIVERY TUBE

The **delivery tube** is next designed. The throat is designed to care for the mixture of water and steam and then the tube is made divergent so as to cut down the velocity and increase the pressure. The velocity at the throat is computed by a formula similar to that for w_m but different in that the pressure is assumed to be atmospheric at this point, due to the opening into the overflow.

$$w'_d = \sqrt{2g \left(\frac{p_b - 14.7}{m_c} \right) 144 + w_b^2} \quad (17)$$

The area in square feet required at this point is given by

$$F_d = \frac{M \left(\frac{1+z}{z} \right)}{\frac{3600}{m_m \Delta w'_d}} \quad (18)$$

$$\Delta = \text{relative density} = 0.8$$

This area F_d of the combining tube fixes the **number of the injector** as most manufacturers use the diameter of this point in millimeters as the **nominal size** or number of the injector. Kneass points out that the ratio $\frac{F_t}{F_d}$ has a value between two and three.

The **shape of the delivery tube** is made in various forms. It has been suggested to reverse the form advised by Nagle for hose nozzles. Nagle suggested that the acceleration be made uniform. If the velocity w'_d is to be reduced to w_b in a given length the accel-

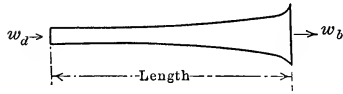

FIG. 134.—Shape for delivery tube.

eration is given by

$$\alpha = \frac{w'_d - w_b}{\text{time}} = \frac{w'_d - w_b}{\frac{\text{length}}{\frac{w_d + w_b}{2}}} = \frac{w'_d{}^2 - w_b^2}{2 \text{ length}} \quad (19)$$

If this occurs in a length $20d_t$, which is a length often used for the delivery tube, the following results:

$$\alpha = \frac{w'_d{}^2 - w_b{}^2}{40d_t} \tag{20}$$

The velocity at any point at distance x from the throat is given by the equation

$$\alpha = \frac{w'_d{}^2 - w_x{}^2}{2x} = \frac{w'_d{}^2 - w_b{}^2}{40d_t}$$

$$\frac{x}{20d_t} \left[1 - \left(\frac{w_b}{w'_d} \right)^2 \right] = 1 - \frac{w_x{}^2}{w'_d{}^2}$$

But

$$\frac{w_x{}^2}{w'_d{}^2} = \left(\frac{\frac{\pi d_x{}^2}{4} Q}{\frac{\pi d_t{}^2}{4} Q} \right) = \frac{d_t{}^4}{d_x{}^4} \tag{21}$$

Hence

$$1 - \frac{x}{20d_t} \left[1 - \frac{w_b{}^2}{w'_d{}^2} \right] = \frac{d_t{}^4}{d_x{}^4}$$

$$d_x = \frac{d_t}{\sqrt[4]{1 - \left(1 - \frac{w_b{}^2}{w'_d{}^2} \right) \frac{x}{20d_t}}}$$

Now in general w_b will be equal to about 4 ft. per second and w'_b about 140 ft. per second so that $\frac{w_b{}^2}{w'_d{}^2} = \frac{1}{1200}$. This is negligible. Hence

$$dx = \frac{d_t}{\sqrt[4]{1 - \frac{x}{20d_t}}} \tag{22}$$

The solution of this is given by the following table.

$\frac{x}{d_t}$	1	2	3	4	8	12	16	19	19.75
$\frac{d_x}{d_t}$	1.013	1.027	1.040	1.058	1.138	1.254	1.496	2.118	3.00

DENSITY

The value of the density of a jet is found by obtaining the temperature of the discharge when the injector will just waste and

the weight of discharge in a given time. If then the theoretical amount in this time and with the pressure be divided into the actual amount of water handled, the square of this will give the density. If for instance an injector lifting 16,600 lbs. of water at 148° F. will just discharge this quantity at 160 lbs. gauge pressure when the area at the throat is 0.00054 sq. ft. the density may be found thus:

The weight of 1 cu. ft. of water at 148° F. is 61.22 lbs. Hence the head corresponding to 160 lbs. with a density of Δ is

$$\frac{160 \times 144}{61.22\Delta} = \frac{376.6}{\Delta} \text{ ft.}$$

$$w'_d = 8.02\sqrt{\frac{376.6}{\Delta}} = \frac{155.7}{\sqrt{\Delta}} \quad (23)$$

Weight discharged

$$= 16,600 = \frac{155.7}{\sqrt{\Delta}} \times 0.00054 \times 3600 \times 61.22\Delta$$

$$\Delta = \left(\frac{16600}{18500}\right)^2 = 0.805$$

IMPACT COEFFICIENT

The **value of k** could be worked out after knowing Δ and finding the various velocities if z is determined experimentally. This has been done and the values found vary from 0.25 to 0.60.

INJECTOR DETAILS

The value of z is fixed by the various velocities and on account of the high velocity of steam acquired by discharges at even low pressures, exhaust steam could be used for feeding boilers or boiler steam could be used to force water into a chamber at a pressure much higher than boiler pressure. Thus an injector could be used for the hydrostatic test of a boiler. The injector shown in Fig. 131 is a **single jet injector** although **double jets** are sometimes used. The first jet lifts the water and forces it into the second nozzle to be driven into the boiler. A **lifting injector** is one which will lift its supply and drive it while a **non-lifting injector** is one which will only force water. In injector testing the term **maximum capacity** means the greatest quantity of water which could be sent through the injector with a given steam pressure and temperature of feed, while the **minimum capacity** is the least that will be discharged

without waste. The **range of capacity** is the difference of these expressed as a percentage of the maximum capacity. The **overflowing temperature** is the highest temperature of operation without overflowing when working at a given pressure. The highest pressure obtainable without wasting is called the **overflowing pressure**.

Injectors can work as **pumps** when operating with other fluids than steam, such as water. In such apparatus water under a great head acquires a velocity so high that it can lift several times its own quantity through a smaller height. The principle and equation of momentum would be the same for this apparatus. An injector operated by water is known as a **jet pump** or **siphon**.

To apply the principles and equations above, suppose it is desired to have an injector pump 6000 lbs. of water per hour at 68° F. into a boiler at 150.1 lbs. gauge pressure. The steam has a quality of 0.96. Assume no pressure on the suction and a lift of 6 ft.

$$p_i = 0.57 \times 164.8 = 93.8$$

$$w_i = 223.7\sqrt{1160.8 - 1116} = 1495 \text{ ft. per sec.}$$

$$w_m = 223.7\sqrt{(1160.8 - 991.1)0.9} = 2760 \text{ ft. per sec.}$$

$$w_c = 223.7\sqrt{(1160.8 - 917.2)0.9} = 3310 \text{ ft. per sec.}$$

$$v_i = 4.34 \text{ cu. ft.}$$

$$v_m = 22.86 \text{ cu. ft.}$$

$$\text{(for } i = 991.1 + 17.0 = 1008.1 \text{ at } 14.7 \text{ lbs.)}$$

$$w_w = 8.02\sqrt{\frac{1}{3}[2.3 \times (-4) + 34 - 6]} = 20.1 \text{ ft. per sec.}$$

$$w_m = 8.02\sqrt{\frac{(164.8 - 4)144}{60 \times 0.8} + \frac{4^2}{64.2}} = 175.5 \text{ ft. per sec.}$$

$$1/2(3310 + z20.1) = (1 + z)175.5$$

$$z = \frac{3310 - 351.0}{351.0 - 20.1} = 8.95$$

$$1160.8 + 8.95 \left[36.1 + \frac{1}{778} \times \frac{20.1^2}{64.4} \right] = 9.95 \left[q'_m + \frac{1}{778} \times \frac{175.5^2}{64.4} \right]$$

$$1160.8 + 323 + 0.072 = 9.95q'_m + 6.17$$

$$q'_m = 148.5$$

$$t_m = 180^\circ \text{ F.}$$

$$m_m = 61.0$$

The value of $m_m\Delta$ of 60×0.8 will not have to be changed as this is as close as the value of Δ will warrant. It will be seen

that the expressions for the kinetic energies are so small that they may be omitted.

$$w_d = 8.02 \sqrt{\frac{(164.8 - 14.7)144}{61 \times 0.8} - \frac{4^2}{64.4}} = 169.6$$

$$\text{Mass of steam per sec.} = \frac{6000}{3600 \times 8.95} = 0.187 \text{ lbs.}$$

$$\text{Mass of water in suction per sec.} = 1.66 \text{ lbs.}$$

$$\text{Mass of mixture per sec.} = 1.847 \text{ lbs.}$$

$$F_t = \frac{0.187 \times 4.34}{1495} = 0.000543 \text{ sq. ft.}$$

$$F_m = \frac{0.187 \times 22.86}{2760} = 0.00155 \text{ sq. ft.}$$

$$F_d = \frac{1.847}{169.6 \times 61.0 \times 0.8} = 0.000224 \text{ sq. ft.}$$

$$\frac{F_t}{F_d} = \frac{0.000543}{0.000224} = 2.42$$

This is between 2 and 3.

$$d_d = \sqrt{\frac{0.000224 \times 144}{0.7854}} = 0.202 \text{ in.} = 5 \text{ mm.}$$

The size is therefore No. 5.

$$d_t = 0.314 \text{ in.}$$

$$d_m = 0.60 \text{ in.}$$

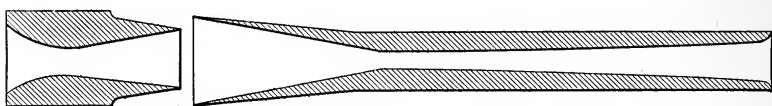

FIG. 135.—Shape for injector tubes.

The table for the delivery tube is as follows:

$x =$	0	0.202	0.404	0.606	0.808	1.616	2.424	3.232	3.838
$d_x =$	0.202	0.204	0.237	0.205	0.207	0.228	0.254	0.302	0.443

The length of the delivery tube is 3.8 in.

The length of the combining tube is $18 \times 0.202 = 3.7$ in.

The length of the entrance to nozzle = $2\frac{1}{2} \times 0.314$
 $= 0.78$ in.

The length of the diverging part of nozzle = 4×0.312
 $= 1.25$ in.

This is shown in Fig. 135.

STEAM TURBINES

The **steam turbine** is operated by the force exerted when a **steam jet** strikes against moving **blades**. If a jet of a certain cross-section, discharging m lbs. of steam per second at a velocity of w_a strikes a blade which is moving in the direction of the jet with a velocity w_b , the steam is reduced to this velocity in the direction of the jet. The acceleration of this substance is

$$\alpha = \frac{w_a - w_b}{\Delta t} \tag{24}$$

if it is assumed that this action takes place in Δt seconds. During this time the amount of mass acted upon is $m\Delta t$. For although all of the fluid leaving the jet would never strike the one vane considered, in all forms of apparatus there are other vanes which come into line so that the amount to be considered on the one vane is the $m\Delta t$ which strikes this vane (if desired Δt would depend on the number of vanes passing the jet per second).

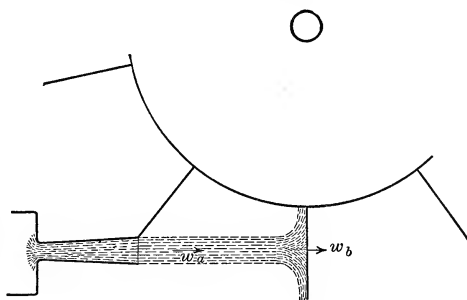

FIG. 136.—Jet impinging on vanes.

The force exerted due to this decrease of velocity is given by the general formula

$$\begin{aligned} P &= m\alpha \tag{25} \\ &= m\Delta t \frac{w_a - w_b}{\Delta t} = m(w_a - w_b) \end{aligned}$$

This expression is in absolute units of force, **poundals** in the English system or **dynes** in the French system. To **change it to pounds or grams** the expression must be **divided by g** giving

$$P = \frac{m(w_a - w_p)}{g} \tag{26}$$

If w_b is made zero this becomes

$$P = \frac{mw_a}{g} \tag{27}$$

In this latter case there is no work done as the blade is sta-

tionary. The force is called the force of impact or the **impulse of the jet**. The nozzle of the jet must feel a force equal to this as some force must be required to produce this flow. This is called the **reaction of the jet**. The word **impulse** refers to the force exerted by the jet when it strikes a body while **reaction** refers to the force on the body from which the jet issues in virtue of which the jet exists. Since in the case of the stationary blade there is no work done, there is no abstraction of energy and the velocity of the steam should not decrease. An investigation made on water jets showed this to be true. Although the velocity in the original direction is destroyed, the value of velocity of the water was not changed; its velocity in all directions along the plane being equal to the original velocity.

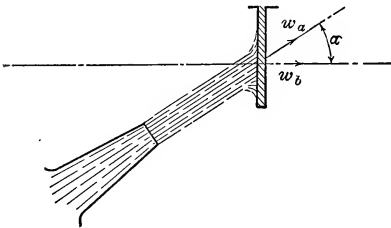

FIG. 137.—Jet impinging on vane at angle with path of motion.

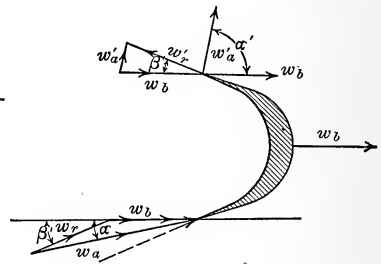

FIG. 138.—Actual and relative velocities of the stream over a moving blade. Entrance and exit triangles.

In equation (26) the numerator represents the change of velocity in the direction of motion of the blade. If the plane of movement of the moving blade is not that of the nozzle so that the actual velocity w_a is inclined at the angle α to the direction of the motion of the blade w_b , equation (26) becomes

$$P = \frac{m}{g}(w_a \cos \alpha - w_b) \quad (28)$$

If in addition to this the substance is thrown off from the blade with an actual velocity w'_a inclined at an angle α' , then the change in velocity in the direction of motion as shown in Fig. 138, would be

$$w_a \cos \alpha - w'_a \cos \alpha'$$

and hence the force would be

$$P = \frac{m}{g}(w_a \cos \alpha - w'_a \cos \alpha') \quad (29)$$

If there were no motion of the blade and no friction, w_a would equal w'_a and the force P would be the force exerted in the direction marked w_b . If however there is motion of the blade, w_a does not equal w'_a and there is a relation between these and the angles of the nozzles and blades if the best conditions prevail.

If w_a is the **actual velocity** from the jet in space and this is directed toward a blade moving with a velocity w_b , the motion of the fluid relative to the blade w_r is found as the component of w_a by the triangle of velocities if w_b is the other component. This means that to one standing on the blade and moving with it, the jet would appear to come in the direction w_r at the angle β to the direction of motion; hence if the blade is to receive this stream without impact or shock it should be tangent to this direction. If now the stream is conducted over the blade to the outlet side and sent off relative to the blade at an angle β' to the direction of motion and with a relative velocity w'_r the actual velocity of discharge in space as the resultant of w'_r and w_b will be found to be w'_a at the angle α' .

Of course it will be seen that as the blade moves away from the nozzle, the jet will not impinge on it but it must be remembered that another blade or vane will be moved up to take the place of the one shown in the figure.

The work done by the force P is equal to the force multiplied by the distance moved through in the direction of P or

$$\text{Work} = P \times \text{distance} \quad (30)$$

$$\text{Distance} = w_b \times \Delta t \quad (31)$$

$$\text{Work} = \frac{m}{g}(w_a \cos \alpha - w'_a \cos \alpha')(w_b \times \Delta t) \quad (32)$$

but $m\Delta t = M$

$$\therefore \text{Work for } M \text{ lbs.} = \frac{M}{g}(w_a \cos \alpha - w'_a \cos \alpha')w_b \quad (33)$$

This is the work for M lb. in any time. If M is the amount per second this will give the work per second.

The **work** may be separated into two parts:

$$\frac{M}{g} w_a \cos \alpha w_b \text{ and } \frac{M}{g} w'_a \cos \alpha' w_b$$

and may be said to be **equal** to the **work done at entrance** by reducing the velocity to zero **minus** the **work done at exit** in giving the fluid its actual discharge velocity.

In other words the reaction of the discharge jet at exit multiplied by the velocity of the blade subtracted from the impulse of the jet at entrance multiplied by the velocity of the blade at entrance is equal to the work per second.

This method of statement in two parts is necessary when a turbine is built with radial flow in which w_b is not the same at entrance and at exit as shown in Fig. 139. In this case

$$\text{work} = \frac{M}{g} [w_b w_a \cos \alpha - w'_b w'_a \cos \alpha'] \quad (34)$$

In most cases steam turbines are of the axial flow type in which the steam flows across from inlet to outlet in a direction

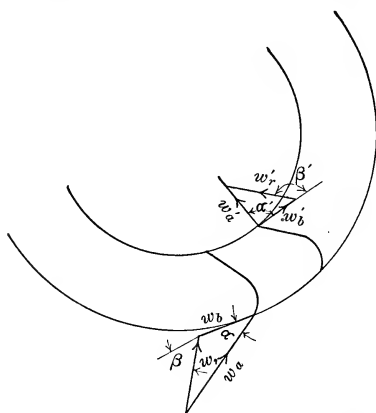

FIG. 139.—Radial flow turbine. Velocities w_b and w'_b are different.

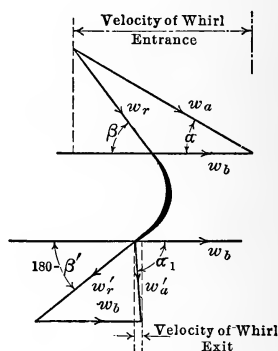

FIG. 140.—Triangles of flow at entrance and discharge.

parallel to the axis and not in a radial direction. Hence $w_b = w'_b$. Equation (33) shows that the work per pound of fluid is

$$\text{work per pound} = \frac{1}{g} (w_a \cos \alpha - w'_a \cos \alpha') w_b \quad (35)$$

$W_b \cos \alpha$ and $w'_b \cos \alpha'$ are the components of the actual velocity of the jets in the direction of motion and are called the **velocities of whirl**. Hence the work per pound is the difference in the velocities of whirl at inlet and outlet multiplied by $\frac{w_b}{g}$. It will be important to remember that if the velocity of whirl at exit from the blade is in the opposite direction to that at entrance that this difference is really an arithmetic sum since the

sign at exit is minus. This is shown clearly by the value of α' . In all cases the angle is measured from w_b when the arrows point toward or away from the vertex for w_b and w_a , or w_b and w_r . The graphical parts of Fig. 138 can be redrawn in Fig. 140.

In this figure w_r may be greater or less than w'_r or equal to it. If there is no drop in pressure across the vane and if there is no friction

$$w_r = w'_r$$

If there is no drop in pressure and if there is friction w_r is greater than w'_r while if there is a drop in pressure there would be an increase in velocity due to the addition of heat energy. Thus

$$w'_r = \sqrt{2g \left[J(i_1 - i_2) + \frac{w_r^2}{2g} \right] [1 - y]} \quad (36)$$

This formula would give w'_r if there is a drop of pressure and friction. Turbines in which there is a drop in pressure across the moving blade are called **reaction turbines** or **pressure turbines** while those in which there are no changes in the pressures as the steam passes over the moving blades are known as **impulse turbines** or **velocity turbines**. These names do not mean that impulse takes place in one form and reaction in the other. Reaction and impulse are present in each. These are only names borrowed from hydraulic turbines which have the meanings attached above.

For impulse turbines with friction

$$w'_r = w_r \sqrt{1 - y} = f w_r \quad (37)$$

$$f = \sqrt{1 - y} \quad (37')$$

Now y depends on the velocity of the steam over the blades. The curves of Fig. 141 have been constructed from data given by Moyer, for stationary and movable blades. S refers to the first and M refers to the second.

In Fig. 140 there is no necessary relation between α , β and β' although α' is fixed by the velocities and the three angles. The following **trigonometric relations** must hold between the **triangles of entrance and exit**:

$$\tan \beta = \frac{w_a \sin \alpha}{w_a \cos \alpha - w_b} \quad (38)$$

$$w_r = \frac{w_a \sin \alpha}{\sin \beta} \quad (39)$$

$$w_b = w_a \cos \alpha - w_r \cos \beta \quad (40)$$

$$w'_r = w_r \sqrt{1 - y} = f w_r \quad (41)$$

$$w'_a = \sqrt{w'_r{}^2 + w_b^2 + 2w_b w'_r \cos \beta'} \quad (42)$$

$$\sin \alpha' = \frac{w'_r \sin \beta'}{w'_a} \quad (43)$$

$$w'_r \cos \beta' = w'_a \cos \alpha' - w_b \quad (40')$$

Thus if w_a , α , β and β' are given in a problem the above equations must be satisfied if there is to be no shock and the equations give the values of the other quantities. A graphical solution is close enough in most problems and the construction

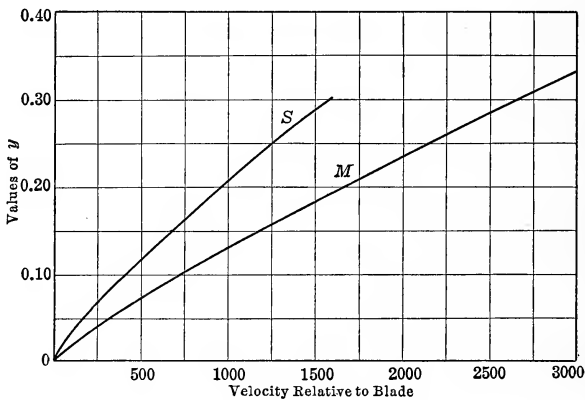

FIG. 141.—Values of y from data given by Moyer.

of the triangles of Fig. 140 will give the results of the above equations.

To save space the lower triangle of Fig. 140 is turned through 180° and placed so that its apex agrees with that of the upper triangle giving Fig. 142. In many turbines β and β' are made supplements of each other giving Fig. 143.

In this figure a represents the **velocity of whirl** at entrance, b represents in a **reversed direction** the velocity of whirl at exit and c represents the **velocity of the blade**. Hence to the scale of the figure, the work per pound of steam is

$$\frac{c}{g} [a - (-b)] = \frac{c(a + b)}{g} \quad (44)$$

The energy in the steam, as it strikes the blade, is

$$\frac{d^2}{2g} \tag{45}$$

since d represents the velocity of the jet leaving the nozzle. The efficiency of application of this jet to the blade is spoken of as the **kinetic efficiency** and is equal to

$$\eta_k = \frac{2c(a + b)}{d^2} \tag{46}$$

In this expression the scale of the figure need not be known as this is a relation between the lengths.

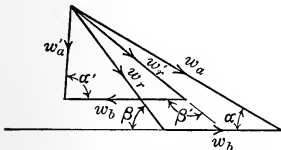

FIG. 142.—Diagram for inlet and outlet triangles with vertices at same point. Friction on blade.

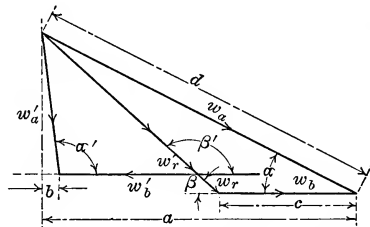

FIG. 143.—Triangles with β' the supplement of β . Friction on blade.

MAXIMUM EFFICIENCY

If w_b or c of Fig. 143 is increased, the quantity a would remain the same although b would be decreased, so that it might increase the product if c were increased. In any event there would be a change and there must be a velocity which would give the **maximum work**. To find this there are **two cases** to consider, **first if α is fixed with $\beta = 180 - \beta'$** , and **second if β and β' are fixed**. There is no need of considering the actual value of w_a as this is only a matter of scale. Of course it must be of fixed value in the discussion, whatever that value is.

$$\text{work} = \frac{w_b}{g} [w_a \cos \alpha - w'_a \cos \alpha'] \tag{35}$$

$$w'_a \cos \alpha' = w'_r \cos \beta' + w_b \tag{40'}$$

$$\text{work} = \frac{w_b}{g} [w_a \cos \alpha - (w'_r \cos \beta' + w_b)]$$

$$\cos \beta = - \cos \beta'; \quad w'_r = fw_r \tag{41}$$

Hence
$$\text{work} = \frac{w_b}{g}[w_a \cos \alpha + fw_r \cos \beta - w_b]$$

where
$$f = \sqrt{1 - y}$$

Now
$$w_r \cos \beta = w_a \cos \alpha - w_b \quad (40)$$

Hence
$$\text{work} = \frac{w_b}{g}[(1 + f)\{w_a \cos \alpha - w_b\}] \quad (47)$$

In this the only variable is w_b , hence the work is a maximum for the value of w_b given by equating the first derivative to zero.

$$\frac{d \text{work}}{dw_b} = 0 = \frac{1 + f}{g}[w_a \cos \alpha - 2w_b]$$

$$w_b = \frac{1}{2} w_a \cos \alpha \quad (48)$$

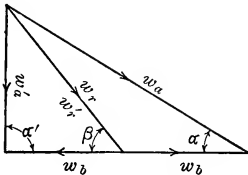

FIG. a.—No friction.

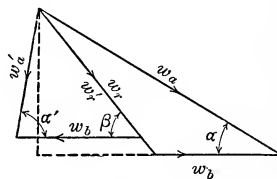

FIG. b.—Friction.

FIG. 144.—Triangles of discharge for maximum efficiency without friction and with friction.

This means that the velocity of the blades should be one-half the velocity of whirl. If $f = 0$ or there is no friction, this same fact is true. The best result occurs when the wheel is moving at one-half the velocity of whirl.

If there is no friction this will cause the absolute velocity of outflow to be perpendicular to the motion of the wheel, while if there is friction there will be a discharge at an angle to this perpendicular as is shown in Fig. 144, *a* and *b*. The work in this case becomes:

$$\begin{aligned} \text{work} &= \frac{1 + f}{g} \left[\frac{1}{2} w_a^2 \cos^2 \alpha - \frac{1}{4} w_a^2 \cos^2 \alpha \right] \\ &= \frac{(1 + f)}{4g} w_a^2 \cos^2 \alpha \end{aligned} \quad (49)$$

The kinetic efficiency is:

$$\eta_k = \frac{\text{work}}{\frac{w_a^2}{2g}} = \frac{(1 + f)}{2} \cos^2 \alpha \quad (50)$$

If there is no friction $f = 1$ and this becomes:

$$\eta_k = \cos^2 \alpha \tag{51}$$

The other case to be considered is that in which β and β' are fixed and α may be varied.

$$\text{Work} = \frac{w_b}{g}(w_a \cos \alpha - w'_a \cos \alpha') \tag{35}$$

$$= \frac{w_b}{g}(w_r \cos \beta + w_b - w'_r \cos \beta' - w_b)$$

$$= \frac{w_b}{g}w_r(\cos \beta - f \cos \beta') \tag{52}$$

Now $\cos \beta - f \cos \beta'$ is a fixed quantity and $w_b w_r$ are variable quantities.

The efficiency in this case is:

$$\eta_k = \frac{\text{work}}{\frac{w_a^2}{2g}} = \frac{2w_b w_r (\cos \beta - f \cos \beta')}{w_a^2} \tag{53}$$

$$w_a^2 = w_b^2 + w_r^2 + 2w_b w_r \cos \beta \tag{42'}$$

$$\eta_k = \frac{2w_b w_r (\cos \beta - f \cos \beta')}{w_b^2 + w_r^2 + 2w_b w_r \cos \beta} \tag{54}$$

or calling $2(\cos \beta - f \cos \beta') = k$ and $\frac{w_r}{w_b} = R$

$$\eta_k = \frac{k}{R + \frac{1}{R} + 2 \cos \beta} \tag{55}$$

$$\frac{d\eta_k}{dR} = 0 = \frac{-k \left[1 - \frac{1}{R^2} \right]}{\left(R + \frac{1}{R} + 2 \cos \beta \right)^2}$$

$$R^2 = 1$$

$$R = \pm 1$$

$$\therefore w_r = w_b \tag{56}$$

and the triangle at entrance is isosceles.

$$\beta = 2\alpha$$

Hence the work becomes:

$$\text{work} = \frac{w_b^2}{g}(\cos \beta - f \cos \beta')$$

Now
$$w_b = \frac{w_a \sin \alpha}{\sin 2\alpha} = \frac{w_a}{2 \cos \alpha}$$

Hence
$$\text{work} = \frac{w_a^2}{2g} \frac{(\cos \beta - f \cos \beta')}{1 + \cos \beta}$$

Since
$$4 \cos^2 \alpha = 2(1 + \cos \beta)$$

$$\eta_k = \frac{(\cos \beta - f \cos \beta')}{1 + \cos \beta} \quad (57)$$

for
$$\beta = 180 - \beta' \text{ and } f = 1$$

$$\eta_k = \frac{\cos \beta}{\frac{1}{2}(1 + \cos \beta)} = \frac{\cos \beta_a}{\cos^2 \frac{1}{2} \beta} = 1 - \tan^2 \frac{1}{2} \beta = 1 - \tan^2 \alpha \quad (58)$$

One other problem of maximum efficiency should be considered. Suppose that it is desired to **operate a given blade at a velocity w_b , what should be the angle α and the velocity w_a to give the greatest efficiency?**

From (52):

$$\text{work} = \frac{w_b w_r}{g} (\cos \beta - f \cos \beta') \quad (52)$$

In this w_b , β , f and β' are known and hence the maximum work would occur when w_r is as large as it can be made. Since residual energy w'_a also increases, the efficiency may not be increased. This problem therefore depends on efficiency.

$$\eta_k = \frac{\text{work}}{\frac{w_a^2}{2g}} = \frac{2w_b w_r (\cos \beta - f \cos \beta')}{w_a^2} = k \frac{w_r}{w_a^2} \quad (59)$$

Now
$$w_a^2 = w_b^2 + w_r^2 + 2w_b w_r \cos \beta \quad (42')$$

$$\therefore \eta_k = \frac{k w_r}{w_b^2 + w_r^2 + 2w_b w_r \cos \beta} \quad (59')$$

This is a maximum when

$$\frac{d\eta_k}{dw_r} = 0; \text{ or } k(w_b^2 + w_r^2 + 2w_b w_r \cos \beta) = k(2w_r^2 + 2w_b w_r \cos \beta)$$

$$w_r^2 = w_b^2 \quad (60)$$

or the triangle at entrance is isosceles.

This fixes w_a by the formula above

$$w_a^2 = 2w_b^2 (1 + \cos \beta),$$

or
$$w_a = \frac{w_b(1 + \cos \beta)}{\cos \frac{1}{2} \beta} \quad (61)$$

This is in reality the same proof as the former one since if for a fixed w_b and blade the triangle is isosceles giving w_a , for a fixed w_a and blade the isosceles triangle should be the most efficient.

The three cases have proven that where the angle α is fixed the turbine blade must travel at one-half the velocity of whirl, whether there be friction or not, and that if the angles β and β' are fixed the best efficiency with either w_a fixed or w_b fixed is obtained when the inflow triangle is isosceles. This holds whether there be friction or not. In the first case without friction, the outflow will be perpendicular to the movement of the blade while in all other cases the line may be inclined slightly. If, however, the speed of the blade is desired and the angle α is fixed, then the highest efficiency is obtained if the velocity of whirl is made twice the speed of the blade. This fixes w_a .

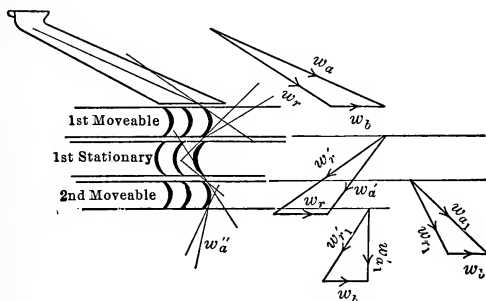

FIG. 145.—Velocity compounding.

In the above figures it has been seen that when the steam is used on one blade the velocity of this blade has to be equal to one-half the velocity of whirl if α is fixed and β and $180 - \beta'$ are fixed. This means that the velocity of the wheel would be very high. To reduce this, the velocity of whirl could be decreased by decreasing the velocity from the nozzle. This is obtained by a small drop in pressure in the nozzle.

If steam is to be used through a large difference in pressure this would have to be utilized in a series of nozzles and blades. This is called **pressure compounding**. Another method is to use a series of movable and fixed blades as shown in Fig. 145, utilizing the high kinetic energy of discharge from one blade in successive blades. This is known as **velocity compounding**.

The velocity diagrams are combined in Fig. 146, in which

$$\beta = 180 - \beta'$$

$$\beta_1 = 180 - \beta'_1$$

In this the work per pound is:

$$\text{work} = \frac{c}{g} [a + b + a_1 + b_1]$$

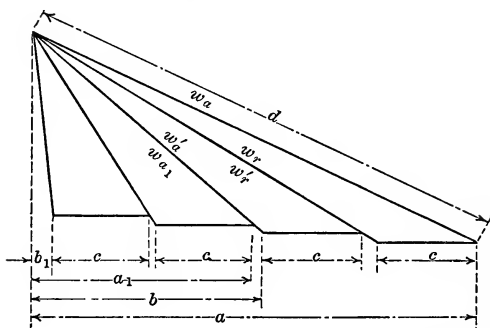

FIG. 146.—Combined diagram for velocities in a turbine with velocity compounding.

The efficiency is:

$$\eta_k = \frac{\text{work}}{w_a^2} = \frac{2c(a + b + a_1 + b_1)}{d^2} \quad (62)$$

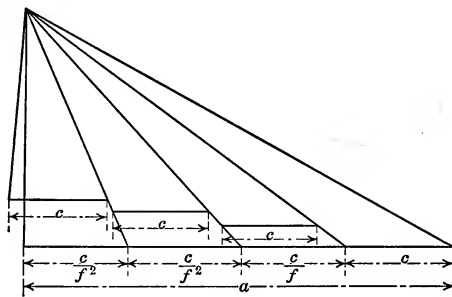

FIG. 147.—Velocity compounding to give the best efficiency.

The value of w_b to make this or the work a maximum is desired.

It has been shown that the last stage to give a maximum result should have a velocity of blade equal to one-half the velocity of whirl and hence the figure to give the best result should be in the form shown in Fig. 147, in which c is one-half of the velocity of whirl

in the last stage. To find the value of c to properly fit value of a of the diagram, continue the lines until they intersect the lower line. The first intercept is c . The second one is $\frac{c}{f}$, since the slanting line w_r has been decreased to $w'_r = fw_r$. From similar triangles

$$\frac{\text{lower intercept}}{c} = \frac{w_r}{fw_r}$$

or
$$\text{intercept} = \frac{c}{f}$$

The second line is decreased in the same manner

$$w_{a1} = fw'_a$$

Hence the third intercept is $\left(\frac{c}{f^2}\right)$ or $\left(\frac{1}{f}\right)\left(\frac{c}{f}\right)$.

The fourth intercept is the same as the third. Hence

$$a = c \left[1 + \frac{1}{f} + \frac{2}{f^2} \right] \tag{63}$$

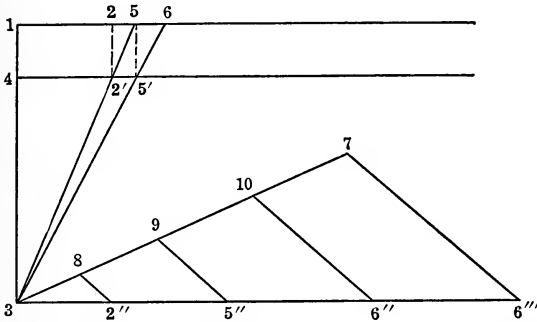

FIG. 148.—Construction for determination of c for multistaging with friction.

If there were three velocity stages this expression would be

$$a = c \left[1 + \frac{1}{f} + \frac{1}{f^2} + \frac{1}{f^3} + \frac{2}{f^4} \right] \tag{64}$$

To construct this so as to find c graphically: lay off any distance 1–2, Fig. 148, which is called c ; at right angles lay off the distance 1–3 equal to unity to any scale and 3–4 equal to f to this scale. Draw an indefinite line from 4 parallel to 1–2, pro-

ject 2 on this line at 2' and draw 3-2' to 5. 1-5 is the distance $\frac{c}{f}$. Project 5 to 5', draw 3-5' to 6 and 1-6 is equal to $\frac{c}{f^2}$.

$$\text{Hence } [(1-2) + (1-5) + (1-6) + (1-6)] = c \left[1 + \frac{1}{f} + \frac{2}{f^2} \right]$$

These are laid off from 3 to 6''' and line 3-7 is laid off equal to a , the velocity of whirl. If 7 and the last 6''' are joined and 2''-8 is drawn parallel to 6'''-7 the distance 3-8 will be equal to the correct distance c for Fig. 146. This same construction can be used for any number of stages.

To make use of the same angle of inlet into the various steps, the angle α of the second fixed blade is changed from the value

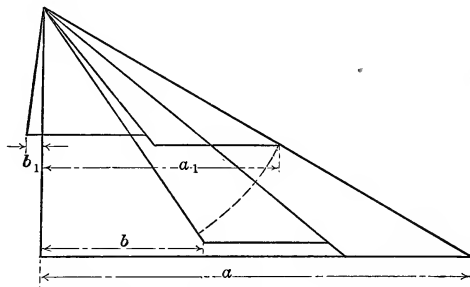

FIG. 149.—Diagram in which $a_1 = a$. Friction on blades.

$180 - \alpha'$ to α . This is shown by the diagram in Fig. 149 where the line has been swung up to the original direction. In this way α_1 is made the same as α and by this action a'_1 has been made larger than before and the efficiency has been increased. The various kinetic efficiencies for these arrangements of blades have been computed and result in the following:

Fig. 144a	$\eta_k = 81$ per cent.
Fig. 144b	$\eta_k = 78$ per cent.
Fig. 147	$\eta_k = 73$ per cent.
Fig. 149	$\eta_k = 84$ per cent.

These have been drawn with $\alpha = \cos^{-1} 0.9$.

The **axial thrust** is due to the **difference between the impulse at entrance** to the moving blade and the **reaction at outlet in the direction of the axis**. The force per pound of steam per second is:

$$P = \frac{1}{g} [w_a \sin \alpha - w'_a \sin \alpha']. \quad (65)$$

Without friction this difference is equal to zero as is seen in Fig. 144. If, however, there is friction this formula does not reduce to zero but to a positive quantity.

In the case of **reaction turbines** there is a **static difference** of pressure between the two sides of the blades which means an axial pressure.

The actual forms of turbines will now be examined. The simplest turbine is the DeLaval turbine.

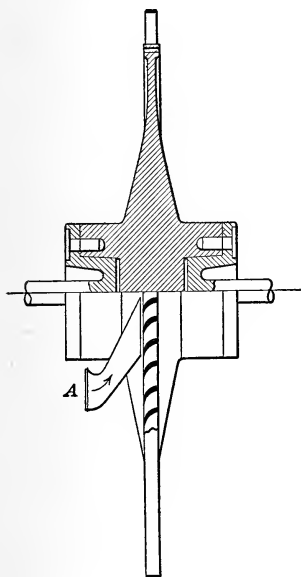

FIG. 150.

FIG. 150.—Section through DeLaval rotor.

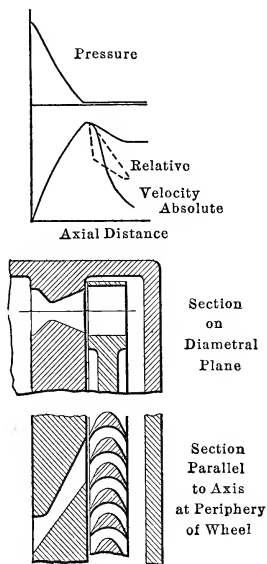

FIG. 151.

FIG. 151.—Sections of DeLaval turbine with curves of pressure and velocity.

Fig. 150 shows a section of the **DeLaval turbine**. This is an impulse turbine in which velocity is generated in a single set of nozzles *A* attached to a steam chest. The velocity is utilized on one set of blades. To increase the power of the machine a number of nozzles are used. The angle of the nozzle relative to the plane of the blade is made as small as possible, as shown in Fig. 150, so that the efficiency which is proportional to $\cos^2 \alpha$ is as large as possible. The peripheral speed of the wheel is very

great. w_a is equal to 3820 ft. per second if the drop in the nozzle is from 150.1 lbs. gauge to 6 lbs. absolute. The speed of the wheel for a value of f of 0.95 and $\cos \alpha = 0.9$ would be

$$w_b = \frac{1}{2} \times 0.9 \times 3820 = 1719 \text{ ft. per sec.}$$

This would mean 16,400 r.p.m. for a radius to the blades of 1 ft. The pressure drop for the axial distances of nozzle and blade and the absolute velocity changes are shown in Fig. 151. This figure gives a section through the axis and one parallel to the axis through the blades and nozzle.

The **Curtis turbine** is shown in Fig. 152. In this steam enters the nozzle at *A* and is discharged against moving vanes. The

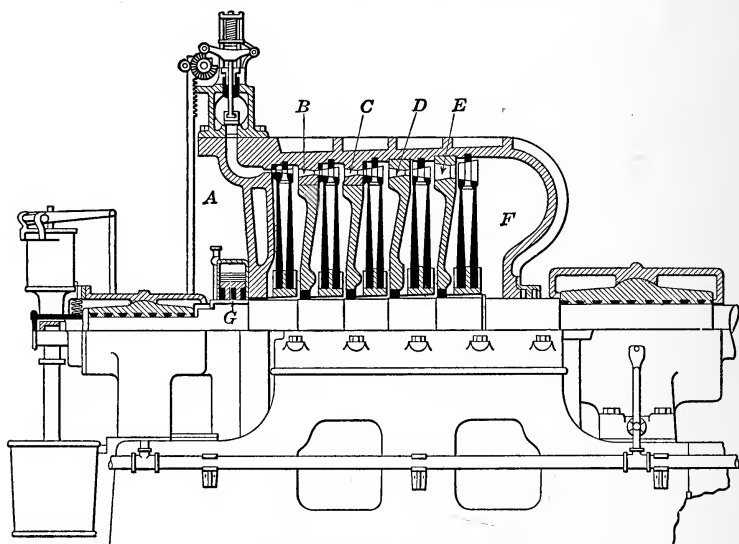

FIG. 152.—Section through horizontal Curtis turbine.

discharge from these moving vanes is guided by stationary vanes to another set of movable vanes, and after discharge from these it is taken to another set of nozzles *B* and discharges into a second set of vanes. In the figure shown there are five sets of nozzles, *A*, *B*, *C*, *D*, and *E*, and to each of these there are two movable and one fixed set of vanes. The pressure drop takes place in five stages, and there is no drop in pressure over the blades. The exhaust space *F* is connected to the condenser. This action is better shown in Fig. 153 in which a section through the axis

and one parallel to the axis of a two-stage turbine are shown side by side following the method used by Moyer. In the figure the pressure is seen to be constant across the sets of vanes, the drop in pressure and consequently the gain in velocity taking place in the nozzles. The turbine is therefore of the **impulse type**. In some cases the nozzles which are arranged in sets extending

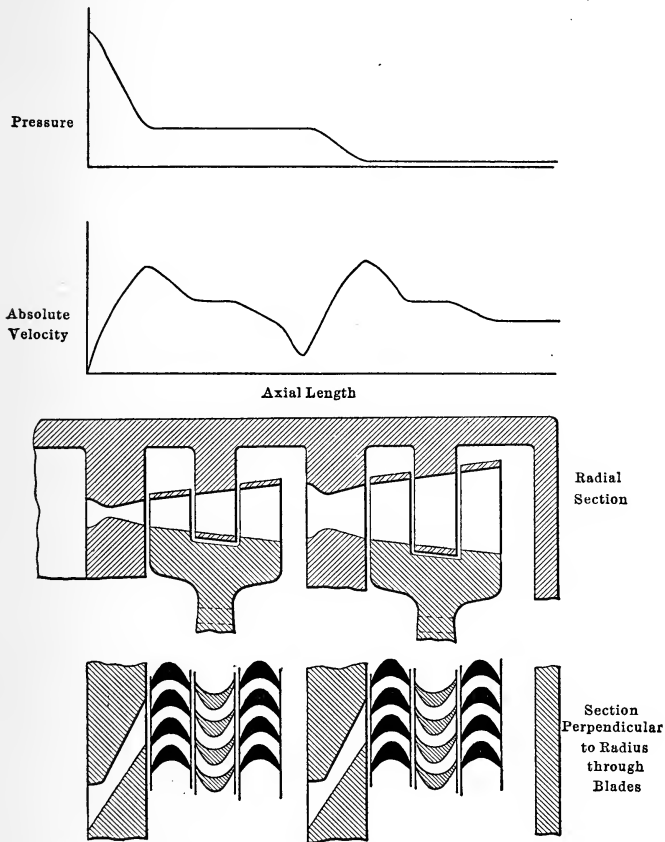

FIG. 153.—Sections of Curtis turbine with curves of pressure and velocity.

over a portion of the circumference are separated into two sets on diametrically opposite parts of the circumference so as to balance the forces in an axial direction. The axial thrust must be balanced by some form of **thrust bearing G**. An auxiliary valve is sometimes used to admit live steam into a lower stage under heavy loads. In this turbine holes are made through the

discs to insure the same pressure throughout the moving elements of one stage.

For the **Rateau turbine** the diagrammatic arrangement of parts is shown in Fig. 154. In this turbine there is only one set of blades to each set of nozzles and there is a drop of pressure in each fixed member. There is no change of pressure across the

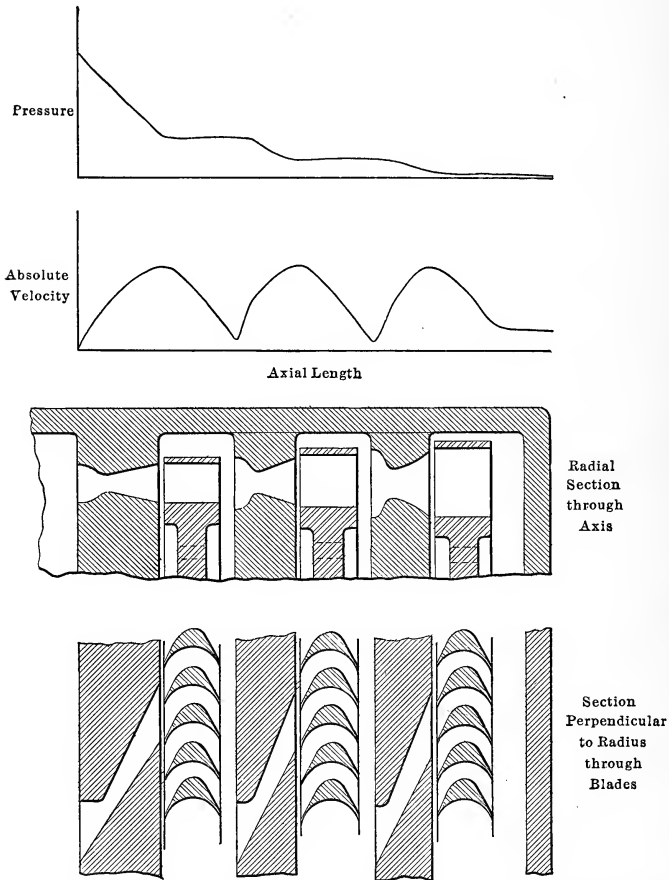

FIG. 154.—Sections of Rateau turbine with curves of pressure and velocity.

movable blades so that this turbine is also of the **impulse type**. As will be seen later the area through which the steam passes as the pressure falls must increase since the velocity relative to the blades is about the same in each set but the specific volume increases. Hence the length of the blades increases.

In all of these the steam is admitted to a portion of the circumference and as the steam pressure falls the portion of the circumference covered is greater so as to give greater area for the steam. The position of the successive nozzles will be advanced in the direction of flow due to the advance of the steam as it passes over the moving blades. This is called **lead**.

The **Parsons turbine** is shown in Fig. 155 and diagrammatically in Fig. 156. In this steam is admitted around the complete circumference to a set of fixed blades. These discharge on the movable set and these in turn to a fixed set from which the action is repeated. In each of these sets of fixed or movable blades there is a pressure drop on all blades and hence this type will be called **reaction type** of turbine.

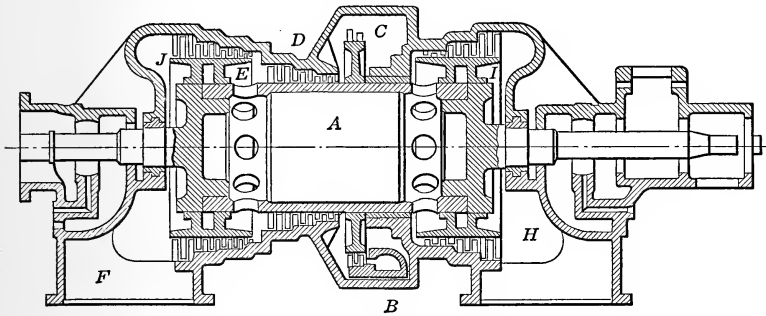

FIG. 155.—Parsons turbine.

In this turbine the axial thrust is balanced by connecting **balancing drums** of proper area to the proper parts of the turbine and connecting the back of the last drum to the space leading to the condenser. A **thrust bearing** is used to ensure alignment. In the type of turbine shown in Fig. 155 a double flow arrangement through the center *A* balances most of the thrust. To make the turbine more efficient the Curtis element *C* has been used for the first reception of the steam. The high-pressure steam is discharged from nozzles attached to the steam chest *B*. The steam from the movable blades *C* then passes to the fixed and movable blades at *D* and finally is discharged at *E*. At this point the steam divides into two parts, one to blades *J* and the condenser connection *F* and the other enters the space *A* at the center of the drum *A* through holes and thence to holes to the space from which the steam enters a set of blades and finally issues into the condenser from the space *H*. This rep-

resents one of the more recent forms of Westinghouse Parsons turbine. The **blades** are mounted on drums *A*, *I* and *J* of different sizes to allow for the changes in volume of the steam. The main steam valve of the ordinary form of Parsons turbine admits steam in puffs controlled by the governor; while under very heavy load the governor begins to operate on a second

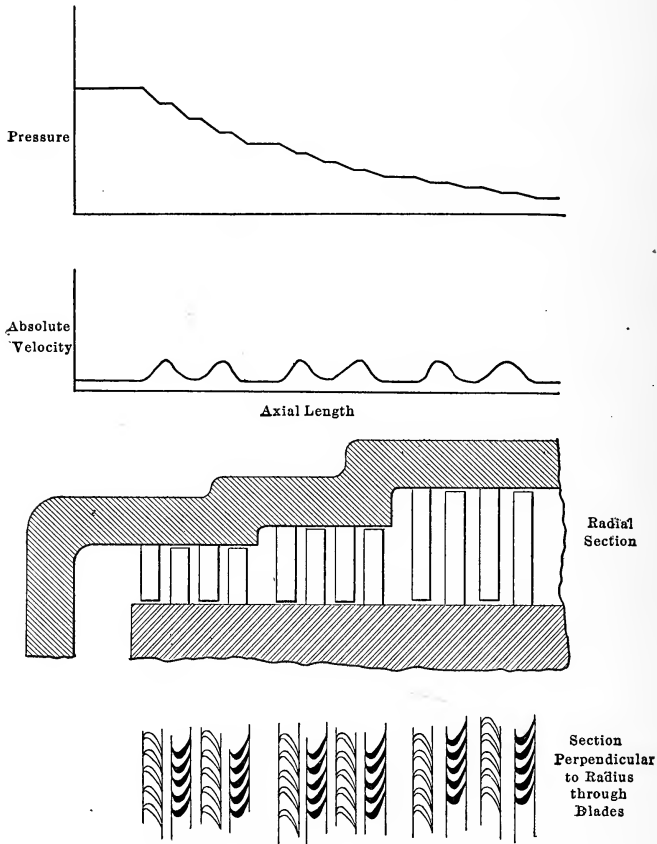

FIG. 156.—Sections of Parsons turbine with curves of pressure and velocity.

valve admitting extra steam to the second stage of the turbine. The **end thrust**, although reduced by the two turbines placed on the same shaft in which the steam passes to right and left, may exist and for that reason a small thrust bearing is used to ensure alignment. The air leakage around the shaft into the steam space which is at the pressure of the condenser is prevented by

some form of steam stuffing box. Fig. 156 shows how the pressure drops on both movable and fixed blades although the absolute velocity decreases over the movable blade. The decrease of absolute velocity would have been greater on the movable blade were there no drop of pressure here.

The great disadvantage of the DeLaval turbine is the high blade speed and the resulting complications. For structural reasons the maximum output of this type is limited to about 300 kw. The absence of packing and the simplicity of the machine do not make up for this great disadvantage. Between the reaction and the other impulse turbines there are advantages on both sides. The reaction turbines are very inefficient on the high-pressure stages, due to the leakage at the ends of the short blades; while in the impulse turbine packing around the shaft between the discs separating the stages is necessary. The combination turbine used by the Westinghouse Company in their use of a Curtis impulse stage for the first utilization of the steam and then the use of the reaction blading after a reduction of pressure has been made to combine the advantages of each type.

EFFICIENCY

The various efficiencies of the turbine may be computed. The nozzle turns the heat $(i_1 - i_2)(1 - y)$ into kinetic energy and $i_1 - q'_o$ heat units have been required per pound. Hence the overall **nozzle efficiency** is

$$\eta_n = \frac{(i_1 - i_2)(1 - y)}{i_1 - q'_o}$$

In some cases there is a series of nozzles in a turbine and if $q_1, q_2, q_3,$ etc., are the amounts of heat turned into work the average nozzle efficiency would be

$$\eta_n = \frac{q_1 + q_2 + q_3 + \dots}{i_1 - q'_o}$$

The **kinetic efficiency** is best worked out by a series of diagrams and is equal to

$$\eta_k = \frac{2c(a + b + a' + b' + \dots)}{d^2}$$

These quantities may be found graphically or computed analytically after drawing such a figure as Fig. 147. The use of

graphical diagrams for the simplification of analytical work in pointing out relations should be well understood.

In the analysis of reaction turbines these two efficiencies cannot be separated. These are computed together as will be shown in the computation for a Parsons turbine.

The loss due to radiation from the turbine may amount to 1 per cent. of the heat supplied and the loss due to leakage varies from 1 per cent. in the case of impulse wheels of the DeLaval form to 5 per cent. in the case of reaction turbines. The efficiency of transmission due to leakage and radiation may be taken together and called the **efficiency of weight**.

$$\eta_w = 1 - (\text{loss of radiation} + \text{loss of leakage}).$$

The next item which reduces the delivery from the shaft of a turbine is the friction of the blades and discs which is known as windage. This amounts to about 5 per cent. for the DeLaval turbines, while for many other forms of discs it may amount to 10 per cent. This depends on the pressure of the steam against the discs and is computed for any given problem by formulæ given in text books on turbine design. In addition to this loss there is loss due to friction at the bearings which may amount to 1 per cent. In some turbines there are oil pumps and gears which consume 1 or 2 per cent. of the power exerted on the blades. If the sum of these be subtracted from unity the difference may be called the **mechanical efficiency**, or

$$\eta_m = 1 - (\text{windage loss} + \text{bearing loss} + \text{gear or pump loss}).$$

The electric generator will have an efficiency of η_e .

The **overall thermal efficiency** is therefore

$$\eta_t = \eta_n \times \eta_k \times \eta_w \times \eta_m \times \eta_e$$

If now the probable steam consumption per kilowatt hour output is desired, the quantity is found as follows:

$$\text{One kilowatt hour} = \frac{2546}{0.746} = 3410 \text{ B.t.u.}$$

$$\text{Amount of heat supplied per lb. steam} = (i - q'_o).$$

$$\text{Amount of heat utilized per lb. steam} = \eta_t (i - q'_o).$$

$$\text{Amount of steam per kilowatt hour} = \frac{3410}{\eta_t (i - q'_o)}.$$

SIMILARITY OF ACTION OF TURBINE AND ENGINE

The expression for the nozzle efficiency is $\frac{(i_1 - i_2)(1 - y)}{i - q'}$.

This is the expression for the efficiency of the Clausius cycle with complete expansion except for the friction term $(1 - y)$. Moreover, the area on the pv plane representing the gain of kinetic energy is the area behind the adiabatic. This is the area of an indicator card with complete expansion. The **theoretic action** of the steam is therefore the **same in the engine and in the turbine**. In the turbine, however, the cool portions never come in contact with the hotter steam and hence there is no initial condensation. For this reason there is no need of free expansion and the toe of the expansion line is utilized. Hence high vacua are of value for turbines. The gain in the T.-S. diagram extends over the whole width of the figure in place of the partial width available in the engine with free expansion.

In the computations for these machines the various types will be considered.

COMPUTATIONS AND DESIGN

DeLaval Turbine.—It is required to get the leading dimensions of a DeLaval turbine to develop 200 kw. with dry steam at 132.5 lbs. gauge pressure and the back pressure is 2.5 lbs. gauge.

$$p_1 = 147.2 \text{ lbs. abs.} \quad i_1 = 1192.2$$

$$p_t = 83.8 \text{ lbs. abs.} \quad i_t = 1146.7$$

$$p_m = 17.2 \text{ lbs. abs.} \quad i_m = 1034.8$$

$$q'_m = 188.4$$

$$w_m = 223.7\sqrt{(i_1 - i_2)(1 - y)} = 223.7\sqrt{(1192.2 - 1034.8)0.88} = 2630 \text{ ft. per sec.}$$

$$w_t = 223.7\sqrt{i_1 - i_t} = 223.7\sqrt{1192.2 - 1146.7} = 1508 \text{ ft. per sec.}$$

$$v_t = 5.043 \text{ cu. ft.}$$

$$v_m = 20.75 \text{ cu. ft. (for } p = 17.19 \text{ and } i = 1034.8 + 0.12 \times 157.4)$$

Assume $\alpha = 20^\circ$

$$w_b = \frac{1}{2} \times 2630 \times \cos 20^\circ = 1315 \times 0.9397 = 1235 \text{ ft. per sec.}$$

$$\tan \beta = \frac{2630 \times 0.342}{1235} = 0.728$$

$$\beta = 36^\circ - 2' = 36^\circ$$

$$w_r = \frac{2630 \times 0.342}{0.588} = 1530$$

$$f \text{ for 1500 ft. per sec.} = 0.9$$

$$\text{Kinetic efficiency} = \frac{1.90}{2} \times (0.94)^2 = 0.840$$

$$\text{Thermal efficiency of nozzle} = \frac{(1192.2 - 1034.8)0.88}{1192.2 - 188.4} = 0.1382$$

$$\text{Radiation and leakage} = 1 \text{ per cent.}$$

$$\text{Friction loss} \left\{ \begin{array}{l} 5 \text{ per cent. for windage} \\ 1 \text{ per cent. for bearings} \\ 2 \text{ per cent. for gears} \end{array} \right\} = 8 \text{ per cent.}$$

$$\text{Generator efficiency} = 95 \text{ per cent.}$$

$$\begin{aligned} \text{Overall efficiency} &= 0.1382 \times 0.99 \times 0.840 \times 0.92 \times 0.95 \\ &= 10.08 \text{ per cent.} \end{aligned}$$

$$\text{Steam per kw.-hr.} = \frac{\frac{2546}{0.746}}{(1192.2 - 188.4)0.1008} = 33.8 \text{ lbs.}$$

$$\text{Total steam per hour} = 200 \times 33.8 = 6760 \text{ lbs.}$$

$$\text{Lbs. per sec.} = 1.87 \text{ lbs.}$$

$$\begin{aligned} \text{Combined area of nozzle throats} &= \frac{1.87 \times 5.043 \times 144}{1508} = \\ &= 0.903 \text{ sq. in.} \end{aligned}$$

$$\text{Combined area of mouths} = \frac{1.87 \times 20.75 \times 144}{2630} = 2.124 \text{ sq. in.}$$

If 10 nozzles are used the areas of the throat will be 0.0903 sq. in. and at the mouth 0.2124 sq. in. The diameter will be 0.339 in. and 0.520 in. respectively. The nozzle will be cut away on an angle so that its length along the face of the blade will be

$$0.520 \times \frac{1}{\sin \alpha} = 0.520 \times \frac{1}{0.342} = 1.52 \text{ in.}$$

Let the blades be made as shown in Fig. 157. The thick part in the center being introduced to stiffen the blade and also to keep the area through the blades of a constant width. The area required for the blade passage per nozzle is

$$F_r = \frac{1.87 \times 20.75 \times 144}{8 \times 1530} = 0.457 \text{ sq. in.}$$

The normal entrance equals this amount and the area along the sides of the blades will be

$$\frac{0.457}{\sin \beta} = \frac{0.457}{0.588} = 0.778$$

If now the length of the nozzle is 1.52 in. the height required to take the steam will be

$$\frac{0.778}{1.52 - \text{blade thickness}} = 0.50 \text{ in.}$$

This is about the height of the nozzle and hence if the blades are made 1 in. high there will be little chance for leakage.

In order to have space for 10 nozzles suppose the radius of the disc be taken as 18 in. Then the number of revolutions for this turbine would be

$$N = \frac{1235 \times 60}{2\pi \times 1.5} = 7850$$

If this is desired at 8000 r.p.m.

$$\text{radius} = \frac{1235 \times 60}{2\pi \times 8000} \times 12 = 17.65 \text{ in.}$$



FIG. 157. — Arrangement of blade thickness to give uniform passage width.

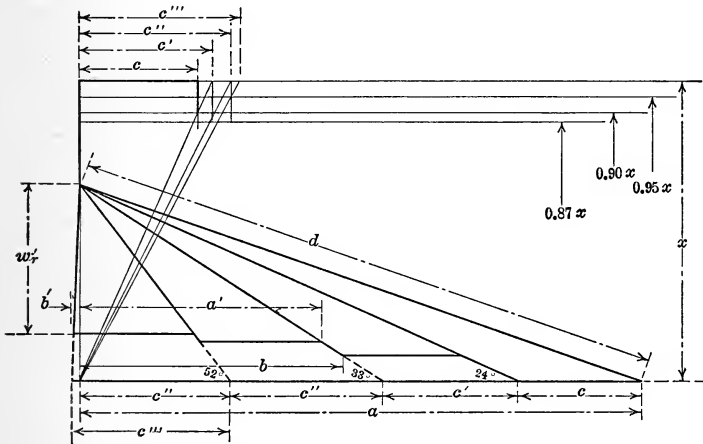

FIG. 158.—Velocity diagram for a two-stage Curtis unit with varying values of f .

Curtis Turbine.—It is desired to find the leading dimensions for a Curtis turbine with four pressure stages between 175 lbs. gauge pressure and 125° F. superheat and 2 in. absolute pressure

at exhaust, each stage to have a double velocity stage or two moving blades and it is required to have w_a from nozzles on each stage the same and the velocities w_b the same on each disc. The power to be developed is 5000 kw.

In such a case it is well to begin by drawing the diagram for velocities and from this compute the kinetic efficiency, as this must be known before the pressures of the various stages may be found. The value of f will not be the same for the various stages, since the velocity over the first movable blades is about 1500 ft. per second, over the fixed blade is about 1200 ft. per second, and over the second movable blade is about 700 ft. per second. The values of f will be 0.9, 0.87 and 0.95. These varying values of f make the construction of Fig. 148 a little more complex as f is not the same on each. Assuming $\alpha = 20^\circ$ and constructing the various values of f for Fig. 148, Fig. 158 has been constructed. From this

$$\frac{2c(a + b + a' + b')}{d^2} = 0.722 = \eta_k$$

This means that $1 - \eta_k$ or 27.8 per cent. of the kinetic energy of the jet of steam remains in the steam when it leaves the vane. This is partially in the form of kinetic energy equal to $\frac{w'_r{}^2}{2g}$ and part in additional heat content from the friction. This heat is therefore to be added to the isentropic heat content i_2 at discharge from the nozzle to find the heat content at entrance into the next nozzle. Whether the kinetic energy is considered as heat or kinetic energy the effect is the same as shown by equation (4) of this chapter.

REHEAT FACTOR

The effect of the heat is to increase the quantity available for the lower stages. This is shown clearly on the Mollier chart. Steam flowing from condition 1 to condition 2 should have the heat content $i_1 - i_2$ changed into kinetic energy. On account of friction in the nozzle only $(1 - y)(i_1 - i_2)$ is changed into kinetic energy and in the Curtis turbine y may be taken as 0.06. This means that $0.06(i_1 - i_2)$ remains as heat in addition to i_2 . On account of the kinetic efficiency of the blades the heat $(1 - \eta_k)(1 - y)(i_1 - i_2)$ still remains in, in addition to the amount which

should remain. Hence the heat content at outflow to next stage is

$$\begin{aligned}
 i_{out} &= i_2 + y_1(i_1 - i_2) + (1 - \eta_k)(1 - y)(i_1 - i_2) \\
 &= i_1 - \eta_k(1 - y)(i_1 - i_2)
 \end{aligned}
 \tag{64}$$

This last statement is equivalent to saying that the heat content remaining is equal to the original heat content minus the work, which gives the point 3 for the proper heat content at the pressure of 2, hence the condition of outflow from the first stage or inflow to the second stage is given by the point 1' at which the pressure is the same as at 2, but i is the i of 3. The entropy s

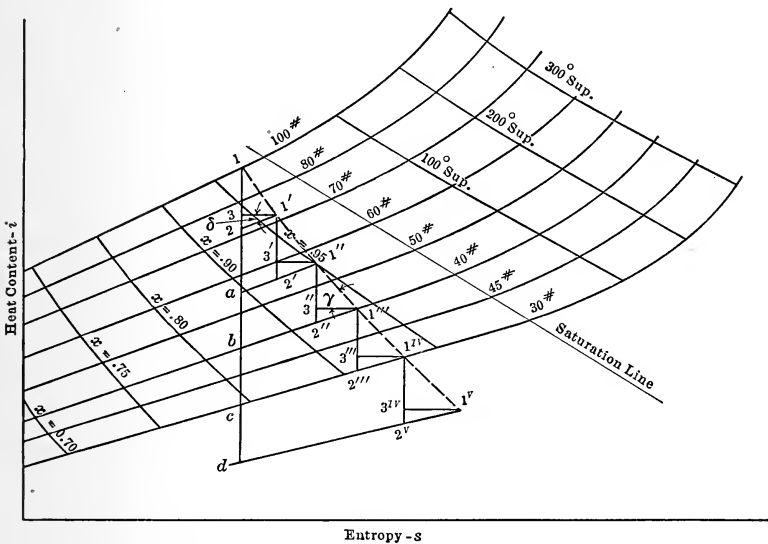

FIG. 159.—Mollier chart arranged for investigation of reheat factor.

has been increased. If $1' - 2'$ is made equal to $1 - 2$ and the same friction is assumed, the velocity of discharge will be the same as that for the first stage and the reheat, as the distance $3 - 2$ is called, will be the same since the same velocity diagram is used for this stage, so that the kinetic efficiency will be the same. This can be continued to $1'' - 2''$ and $1''' - 2'''$. Since the distances $1 - 2$, $1' - 2'$, $1'' - 2''$ and $1''' - 2'''$ are all the same the velocities from all nozzles will be equal and the diagram of Fig. 158 is the same for all stages. Hence the angles of similar blades will be equal as will the velocities of

the blades. If the various pressure lines are continued back to the entropy line through 1 and 2 and the intercepts marked a , b and c , it will be found that on account of the form of the diagram, spreading out as entropy increases due to the properties of steam, $1 - 2$ is greater than $2 - a$; $2 - a$ is greater than $a - b$; and $a - b$ is greater than $b - c$. In other words, 5 times $1 - 2$, which is the heat available, is greater than $1 - d$, the heat which would have been available for a single expansion. The ratio of the length $1 - 2$ to the length $\frac{1 - d}{5}$ or $\frac{\text{heat on adiabatic for one stage}}{n}$ is called the **reheat factor**.

The determination of this has been discussed by Edgar Buckingham of the U. S. Bureau of Standards, and is found in Vol. vii of the Bulletin of the Bureau of Standards, Washington, D. C. It is also given in Reprint No. 167. If this factor is called ($R. H.$) and is known in any case, it is immediately possible to find the length $1 - 2$ for all stages since

$$1 - 2 = \left(\frac{1 - d}{n} \right) (R. H.) \quad (65)$$

Since $1 - 3$ of Fig. 159 is the heat actually turned into work and $1 - 2$ is the heat applied, the efficiency of each stage is

$$\eta_s = \frac{1 - 3}{1 - 2}$$

This is the product of $\eta_n \times \eta_k$ or η_s .

In the triangle 321' in the saturated region

$$i_3 - i_2 = 3 - 2 = (x_{1'} - x_2)r$$

since the change in heat along a constant pressure line is equal to the change in quality multiplied by the heat of vaporization.

$$\text{Now} \quad s_{1'} - s_3 = 1' - 3 = (x_{1'} - x_2) \frac{r}{T}$$

$$\text{Hence} \quad \frac{2 - 3}{1' - 3} \text{ or } \tan \delta = \frac{(x_{1'} - x_2)r}{(x_{1'} - x_2) \frac{r}{T}} = T$$

or the slope of the curve of constant pressure with the horizontal is proportional to the temperature or

$$\tan \delta = kT \quad (66)$$

Since T is constant for a given pressure in the saturated region δ is constant and these lines of constant pressure are straight lines and since $i = 0$ when $s = 0$ they should pass through the origin although this is not strictly true for after condensation sets in the variation between i and s is logarithmic in form. However the divergence between these lines is so slight that the slope will not change much if they are assumed to pass through zero. Buckingham calls attention to the fact that a slight change in the lines will bring this about. With this understanding as to the origin

$$\tan \delta = \frac{i}{s} \tag{67}$$

If now γ be the angle between $1 - 1'$ and $3 - 1'$ the tangent may be written as

$$\tan \gamma = - \frac{di}{ds} \tag{68}$$

The negative sign must be used since di is negative when ds is positive during expansion.

It is possible to write

$$\tan \gamma = - \frac{1 - 3}{1' - 3}$$

Now $1 - 3 = \eta_s 1 - 2$

and $1' - 3 = \frac{2 - 3}{\tan \delta} = \frac{(1 - \eta_s) 1 - 2}{\tan \delta}$

$$\therefore \tan \gamma = \frac{\eta_s}{1 - \eta_s} \tan \delta = \frac{\eta_s}{1 - \eta_s} \frac{i}{s}$$

Hence $-\frac{di}{ds} = \frac{\eta_s}{1 - \eta_s} \frac{i}{s}$

or $-\frac{di}{i} = \frac{\eta_s}{1 - \eta_s} \frac{ds}{s}$

If this is integrated from 1 to the last point say 1^v the following results:

$$\begin{aligned} \text{Log}_e \frac{i^v}{i_1} &= \frac{\eta_s}{1 - \eta_s} \text{log}_e \frac{s_1}{s^v} \\ \frac{i^v}{i_1} &= \left(\frac{s_1}{s^v}\right)^{\frac{\eta_s}{1 - \eta_s}} = \left(\frac{i_d}{i^v}\right)^{\frac{\eta_s}{1 - \eta_s}} \end{aligned} \tag{69}$$

Since $\frac{i_d}{i^v} = \frac{s_d}{s^v}$

because
$$\tan \delta = \frac{i_d}{s_d} = \frac{i^v}{s^v}$$

but
$$s_d = s_1$$

$$\therefore \frac{s_1}{s^v} = \frac{i_d}{i^v}$$

It is also seen that $\tan \delta = kT$, hence

$$i_d = kT_d s_d.$$

$$i_1 = kT_1 s_1 = kT_1 s_d$$

$$\therefore i_d = i_1 \frac{T_d}{T_1} \quad (70)$$

and
$$\frac{i_d}{i^v} = \frac{i_1}{i^v} \frac{T_d}{T_1}$$

Substituting this above

$$\frac{i^v}{i_1} = \left(\frac{i_1}{i^v} \frac{T_d}{T_1} \right)^{\frac{\eta_s}{1-\eta_s}}$$

$$\left(\frac{i^v}{i_1} \right)^{1 + \frac{\eta_s}{1-\eta_s}} = \left(\frac{T_d}{T_1} \right)^{\frac{\eta_s}{1-\eta_s}}$$

$$\frac{i^v}{i_1} = \left(\frac{T_d}{T_1} \right)^{\eta_s}$$

$$i_1 - i^v = i_1 \left(1 - \left(\frac{T_d}{T_1} \right)^{\eta_s} \right) \quad (71)$$

Now if the efficiency of the stages were all η_s , the total heat drop usable on one stage would be $\eta_s(i_1 - i_d)$ and this would be equal to

$$\eta_s i_1 \left(1 - \frac{i_d}{i_1} \right) = \eta_s i_1 \left(1 - \frac{T_d}{T_1} \right)$$

Since
$$i_d = kT_d s_d$$

$$i_1 = kT_1 s_1$$

$$s_1 = s_d$$

Now the reheat factor = $\frac{\text{amount available with reheat}}{\text{amount available with no reheat}}$

$$\therefore R.H. = \frac{i_1 - i^v}{\eta_s(i_1 - i_d)} = \frac{1 - \left(\frac{T_d}{T_1} \right)^{\eta_s}}{\eta_s \left(1 - \frac{T_d}{T_1} \right)} \quad (72)$$

For any given problem in which the limiting pressures and

stage efficiency are known the temperatures may be found and this formula may be computed. The temperatures to be used are those of saturation and in the superheated regions these lines of constant pressure bend a slight amount making a slight error in the application of the formula but not enough to prevent its use as a guide, at least if the saturation temperature is used for the upper temperature. The formula is true for an infinite number of differential steps while for a finite number of definite steps the reheat factor would be slightly different. The formula is therefore of value to fix the first value of 1-2 although this may have to be adjusted in computing a problem.

The value of η_s for this problem is

$$\eta_s = 0.94 \times 0.722 = 0.679$$

$$T \text{ of saturation for 175 lbs.} = 370.5 + 460.7 = 831.2^\circ.$$

$$T \text{ of 0.98 lbs. abs. pressure} = 101.1 + 460.7 = 561.8^\circ.$$

$$R.H. = \frac{1 - \left(\frac{561.8}{831.2}\right)^{0.68}}{0.68 \left(1 - \frac{561.8}{831.2}\right)} = \frac{0.23}{0.68 \times 0.324} = 1.04$$

The Mollier chart reared by Marks and Davis will be used for this problem:

$$p_1 = 189.7 \quad \text{superheat} = 125^\circ \text{ F.} \quad s_1 = 1.646 \quad i_1 = 1297$$

$$p_c = 0.98 \quad \text{quality} = 0.82 \quad s_c = 1.646 \quad i_c = 918$$

$$R.H. \frac{i_1 - i_c}{4} = 1.04 \frac{1297 - 918}{4} = 98.7 = i_1 - i_2$$

$$\text{Reheat} = (1 - 0.68) \times 98.7 = 31.6 \text{ B.t.u.}$$

$$i_2 = 1297 - 98.7 = 1198.3$$

$$i_{1'} = 1198.3 + 31.6 = 1229.9$$

$$i_{2'} = 1229.9 - 98.7 = 1131.2$$

$$i_{1''} = 1131.2 + 31.6 = 1162.8$$

$$i_{2''} = 1162.8 - 98.7 = 1064.1$$

$$p_2 = 75 \quad \text{Superheat} = 32^\circ \text{ F.}$$

$$p_{1'} = 75 \quad s = 1.684 \text{ superheat} = 95^\circ \text{ F.}$$

$$p_{2'} = 22 \quad x = 0.97$$

$$p_{1''} = 22 \quad s = 1.728 \text{ superheat } 6^\circ \text{ F.}$$

$$p_{2''} = 5.3 \quad x = 0.93$$

$$i_{1'''} = 1065.9 + 31.6 = 1095.7 \quad p_{1'''} = 5.3 \quad s = 1.781 \quad x = 0.965$$

$$i_{2'''} = 1095.5 - 98.7 = 996.8 \quad p_{2'''} = 1.0 \quad s = 1.781 \quad x = 0.895$$

The final pressure desired was 0.98 lbs. and this result is as close as can be expected. The value of $i_1 - i_2$ is correct and w_a may now be found.

$$w_a = 223.7\sqrt{98.7 \times 0.94} = 2146 \text{ ft. per sec.}$$

This holds for each nozzle.

The thermal efficiency of the nozzles and blades is therefore:

$$\eta = \frac{\eta_s(i_1 - i_2)n}{i_1 - q'_o} = \frac{0.68 \times 4 \times 98.7}{1297 - 69.2} = 0.219$$

The overall efficiency is found by assuming:

$$\eta_w = 1 - (0.01 + 0.02) = 0.97$$

$$\eta_m = 1 - (0.07 + 0.01) = 0.92$$

$$\eta_e = 0.96$$

$$\therefore \eta_t = 0.219 \times 0.97 \times 0.92 \times 0.96 = 0.188 \\ = 18.8 \text{ per cent.}$$

$$\text{The probable steam per kw.-hr.} = \frac{3410}{0.188 \times 1227.8} = 14.8.$$

The actual amount guaranteed by the builders was 15.75 lbs. per kilowatt hour.

Total steam for 5000 kw. = $5000 \times 14.8 = 74,000$ lbs. per hour.

Steam per second = 20.55 lbs.

The nozzles must be investigated for the presence of the throat.

$$p_{i1} = 0.57 \times 189.7 = 108$$

$$p_{i2} = 0.57 \times 75 = 42.8$$

$$p_{i3} = 0.57 \times 22 = 12.55$$

$$p_{i4} = 0.57 \times 5.3 = 3.02$$

There is a throat in each nozzle and i at these pressures is found from the chart of Marks and Davis.

i (for 108.0 lbs. $s = 1.646$) = 1230, 104° superheat = quality

i (for 42.8 lbs. $s = 1.684$) = 1180, 42° superheat = quality

i (for 12.55 lbs. $s = 1.728$) = 1118, $0.97 =$ quality

i (for 3.02 lbs. $s = 1.781$) = 1059, $0.94 =$ quality

$$w_i = 223.7\sqrt{1297 - 1230} = 1830 \text{ ft. per sec.}$$

$$w_{i'} = 223.7\sqrt{1229.9 - 1180} = 1580 \text{ ft. per sec.}$$

$$w_{i''} = 223.7\sqrt{1162.6 - 1118} = 1493 \text{ ft. per sec.}$$

$$w_{i'''} = 223.7\sqrt{1095.7 - 1059} = 1350 \text{ ft. per sec.}$$

The values of the specific volumes are given below:

$$\begin{aligned}
 v_t &= 4.99 \text{ cu. ft.} \\
 v_{v'} &= 10.56 \text{ cu. ft.} \\
 v_{v''} &= 30.2 \text{ cu. ft.} \\
 v_{v'''} &= 110.0 \text{ cu. ft.} \\
 v_m &= 6.24 \text{ cu. ft. for } p = 75, i = 1297 - 0.94 \times 98.7 = 1204 \\
 v_{m'} &= 18.0 \text{ cu. ft. for } p = 22, i = 1229.9 - 93 = 1136.9 \\
 v_{m''} &= 64.8 \text{ cu. ft. for } p = 5.3, i = 1162.2 - 93 = 1069.2 \\
 v_{m'''} &= 307 \text{ cu. ft. for } p = 0.98, i = 1095.5 - 93 = 1002.5
 \end{aligned}$$

The specific volumes of the steam leaving the blades is equal to the specific volume for the pressures at these points and for the heat content of exit plus the sum of the friction loss in the nozzles and on the blades. The friction loss of the blades plus the residual kinetic energy is equal to $(1-\eta)$ or friction equals

$$1 - \eta - r.e.$$

where $r.e.$ is equal to $\frac{w_r^2}{w_a^2}$

From Fig. 158 $\frac{w_r^2}{w_a^2} = \left(\frac{e}{d}\right)^2 = 0.065$

$$\begin{aligned}
 \text{Friction loss on blades} &= 1 - 0.722 - 0.065 = 0.213 \\
 \text{Total friction effect} &= 0.06 + 0.94 \times 0.213 = 0.260 \\
 \text{Heat from friction per stage} &= 98.7 \times 0.260 = 24.7 \text{ B.t.u.}
 \end{aligned}$$

$$\begin{aligned}
 v_o &= 6.51 \text{ for } p = 75, i = 1198.3 + 24.7 = 1223.0 \\
 v_{o'} &= 18.30 \text{ for } p = 22, i = 1131.2 + 24.7 = 1155.9 \\
 v_{o''} &= 65.5 \text{ for } p = 5.3, i = 1063.9 + 24.7 = 1088.6 \\
 v_{o'''} &= 303.4 \text{ for } p = 0.98, i = 996.8 + 24.7 = 1021.5
 \end{aligned}$$

From Fig. 156

$$w_r = \frac{1.54}{4.96} \times 2146 = 690 \text{ ft. per sec.}$$

The areas then at the various points in square inches are given as follows:

$$\begin{aligned}
 F_t &= \frac{20.55 \times 4.99 \times 144}{1830} = 8.06 \text{ sq. in.} \\
 F_{v'} &= \frac{20.55 \times 10.56 \times 144}{1580} = 19.70 \text{ sq. in.} \\
 F_{v''} &= \frac{29.55 \times 30.2 \times 144}{1493} = 59.70 \text{ sq. in.}
 \end{aligned}$$

$$F_{v'''} = \frac{20.55 \times 110.0 \times 144}{1350} = 241.0 \text{ sq. in.}$$

$$F_m = \frac{20.55 \times 6.24 \times 144}{2146} = 8.58 \text{ sq. in.}$$

$$F_{m'} = \frac{20.55 \times 18.0 \times 144}{2146} = 24.70 \text{ sq. in.}$$

$$F_{m''} = \frac{20.55 \times 64.8 \times 144}{2146} = 89.0 \text{ sq. in.}$$

$$F_{m'''} = \frac{20.55 \times 307.0 \times 144}{2146} = 422.0 \text{ sq. in.}$$

The outlet area from the last blade of each stage is given by:

$$F_o = \frac{20.55 \times 6.51 \times 144}{690} = 27.9 \text{ sq. in.}$$

$$F_{o'} = \frac{20.55 \times 18.30 \times 144}{690} = 79.7 \text{ sq. in.}$$

$$F_{o''} = \frac{20.55 \times 65.5 \times 144}{690} = 281.0 \text{ sq. in.}$$

$$F_{o'''} = \frac{20.55 \times 303.4 \times 144}{690} = 1300.0 \text{ sq. in.}$$

For the outlet area from the blade of each stage use specific volumes at about one-third the difference between the volumes for O and m , using from Fig. 156,

$$w_{v'} = \frac{3.49}{4.96} \times 2146 = 1515 \text{ ft. per sec.}$$

$$F'_{o} = \frac{20.55 \times 6.36 \times 144}{1515} = 12.4 \text{ sq. in.}$$

$$F'_{o'} = \frac{20.55 \times 18.17 \times 144}{1515} = 35.5 \text{ sq. in.}$$

$$F'_{o''} = \frac{20.55 \times 65.3 \times 144}{1515} = 127.6 \text{ sq. in.}$$

$$F'_{o'''} = \frac{20.55 \times 306.9 \times 144}{1515} = 600.0 \text{ sq. in.}$$

For the outlet from the fixed blades the velocities are each equal to 1040 ft. per second and the specific volumes may be taken as the mean of those in the last two cases, giving:

$$\begin{aligned} F_f &= 18.4 \text{ sq. in.} \\ F_{f'} &= 52.0 \text{ sq. in.} \\ F_{f''} &= 186.0 \text{ sq. in.} \\ F_{f'''} &= 870.0 \text{ sq. in.} \end{aligned}$$

If the nozzles of the first stage be made of $\frac{1}{2}$ sq. in. cross section of mouth there would be nine of these on each side of the turbine. These will give an area of 9 sq. in. where 8.58 have been required. If these are made $\frac{3}{4}$ in. wide the length of each on the circular face will be:

$$\frac{\frac{1}{2}}{\frac{3}{4} \sin 20^\circ} = 1.95 \text{ in.}$$

These will take up about 30 in. of the circumference if there is allowance made for the partitions between each two nozzles.

The throats of these nozzles will each be:

$$\frac{1}{2} \times \frac{8.06}{8.58} = 0.47 \text{ sq. in.}$$

or $0.75 \times 0.63 \text{ in.}$

For the second stage the mouth may be made 1 sq. in. in area requiring 13 on each side. If made 1 in. wide the length will be

$$\frac{1}{0.34} = 2.92 \text{ in.}$$

The throat will contain $26 \times \frac{19.7}{24.7} = 20.8 \text{ sq. in.}$ If this is 1 in. wide the depth will be

$$\frac{20.8}{26 \times 0.34} = 2.35 \text{ in.}$$

These will take up about 42 in. on each side.

If the areas for the third stage are made 3 sq. in. each there will be sixteen necessary on each side and these may be worked out as before using $1\frac{3}{4}$ in. for the width.

On the last stage the area of each might be made 9 sq. in. requiring 25 on each side and the width would be $4\frac{1}{2}$ in. These would take up about 160 in. on a side or 320 in. in the circumference. If this were to use the complete circumference the diameter of the turbine pitch circle would be 102 in. or 8 ft. 6 in. If this is considered too large the width might be made 6 in., this would require 92 in. diameter. The blades of the first

movable set would be slightly higher than the width of the nozzle mouth. They will be determined by their area at discharge.

These will have to be investigated from

$$F_o = \text{length} \times \text{height} \times \sin \beta.$$

Now $F_m = \text{length} \times \text{height} \times \sin \alpha.$

Hence since length is the same for nozzle and blades

$$\text{height}_o = h_m \frac{F_o \sin \alpha}{F_m \sin \beta}$$

$$h_o = \frac{3}{4} \times \frac{12.4}{8.58} \times \frac{0.34}{0.41} = 0.9 \text{ in.}$$

$$h_{o'} = 1 \times \frac{35.50}{24.7} \times \frac{0.34}{0.41} = 1.19 \text{ in.}$$

$$h_{o''} = 1.75 \times \frac{127.6}{89} \times \frac{0.34}{0.41} = 2.20 \text{ in.}$$

$$h_{o'''} = 4\frac{1}{2} \times \frac{600}{422} \times \frac{0.34}{0.41} = 5.3 \text{ in.}$$

The heights of the fixed blades will have to be made longer than the first movable blades because although the specific volume increases slightly, due to friction, there is a marked decrease in axial velocity as seen from Fig. 158.

$$h_f = \frac{3}{4} \times \frac{18.4}{8.58} \times \frac{0.34}{0.54} = 1.015 \text{ in.}$$

$$h_{f'} = 1 \times \frac{52.0}{24.7} \times \frac{0.34}{0.54} = 1.32 \text{ in.}$$

$$h_{f''} = 1.75 \times \frac{186}{89} \times \frac{0.34}{0.54} = 2.3 \text{ in.}$$

$$h_{f'''} = 4\frac{1}{2} \times \frac{870}{422} \times \frac{0.34}{0.54} = 5.83 \text{ in.}$$

For the outflow edge of the second movable blade the heights are given by:

$$h'_o = \frac{3}{4} \times \frac{27.9}{8.58} \times \frac{0.34}{0.79} = 1.07 \text{ in.}$$

$$h'_{o'} = 1 \times \frac{79.7}{24.7} \times \frac{0.34}{0.79} = 1.45 \text{ in.}$$

$$h'_{o''} = 1.75 \times \frac{281}{89} \times \frac{0.34}{0.79} = 2.41 \text{ in.}$$

$$h'_{o'''} = 4\frac{1}{2} \times \frac{1300}{422} \times \frac{0.34}{0.79} = 5.98 \text{ in.}$$

In this it is seen that the blades will increase from $\frac{3}{4}$ -in. nozzle to 0.9-in. movable blade, 1.02-in. fixed blade and 1.07-in. second movable blade or, to allow for spreading, say $\frac{3}{4}$ in., $1\frac{1}{8}$ in., $1\frac{1}{4}$ in. and $1\frac{3}{8}$ in. These for the second stage would be 1 in., $1\frac{3}{8}$ in., $1\frac{1}{2}$ in. and $1\frac{5}{8}$ in.; for the third stage $1\frac{3}{4}$ in., $2\frac{3}{8}$ in., $2\frac{1}{2}$ in. and $2\frac{5}{8}$ in.; and for the last stage $4\frac{1}{2}$ in., $5\frac{1}{2}$ in., 6 in. and $6\frac{1}{4}$ in.

The angles of the nozzles would be 20° , the first movable blade would have angles of 24° at entrance, the fixed blade would have an angle of 33° and the last movable blade would be 52° . The outlet angles are supplements of the above as the blades are all symmetrical.

The speed of the wheel, from Fig. 158 is

$$\frac{1}{4.96} \times 2146 = 433 \text{ ft. per sec.}$$

The speed with a diameter of 102 in. would be 975 r.p.m. If 1000 r.p.m. be taken then $D = 100$ in. This is a possibility. The customary speed is 1500 r.p.m. showing that a smaller diameter is used. To use this diameter of 66 in., the heights of the vanes would have to be increased by 50 per cent. This would make the last blades $9\frac{3}{8}$ in. long.

Rateau Turbine.—In this turbine there are many pressure stages and only one velocity stage to each pressure stage. If this is the case and 20° is the value of α and the desired speed of blades is about 500 ft. per second, the velocity across the vanes will be 750 ft. per second which gives

$$f = 0.94$$

$$\eta_k = \frac{1 + 0.94}{2} \cos^2 \alpha = 0.97 \times (0.94)^2 = 0.857$$

$$\eta_s = \eta_n \times \eta_k = 0.94 \times 0.857 = 0.805$$

Suppose the turbine is to work through the same range of pressures as the Curtis turbine above:

$$R.H. = \frac{1 - \left(\frac{561.8}{831.2}\right)^{0.805}}{0.805 \left(1 - \frac{561.8}{831.2}\right)} = \frac{0.27}{0.805 \times 0.324} = 1.035$$

The heat required to give a velocity of 500 ft. with $\alpha = 20^\circ$ and $f = 0.94$ is found thus:

$$w_a = \frac{2w_b}{\cos \alpha} = \frac{1000}{0.94} = 1065$$

The available heat for this is

$$i_1 - i_2 = 0.94 \left(\frac{1065}{223.7} \right)^2 = 21.5 \text{ B.t.u.}$$

The amount required per stage is

$$\frac{21.5}{1.035} = 20.4$$

$$\text{Number of stages} = \frac{1297 - 918}{20.4} = 18.7$$

Use 20 stages.

$$i_1 - i_2 = \frac{1297 - 918}{20} \times 1.035 = 19.7$$

$$w_a = 223.7 \sqrt{19.7 \times 0.94} = 961 \text{ ft. per sec.}$$

$$w_b = \frac{961 \times 0.94}{2} = 452 \text{ ft. per sec.}$$

The heat returned at each stage = $19.7 \times (1 - 0.805) = 3.84$ B.t.u.

Heat used = $19.7 - 3.84 = 15.06$ B.t.u.

$$\text{Actual thermal efficiency} = \frac{15.06 \times 20}{1297 - 69.2} = 0.245$$

$$\text{Overall efficiency} = 0.245 \times 0.97 \times 0.90 \times 0.96 = 0.205$$

The steam consumption per kilowatt hour would be

$$M = \frac{3410}{0.205 \times 1127.8} = 14.75 \text{ lbs.}$$

Parsons Turbine.—In this turbine the **reheat factor** will have to be worked out from the blade efficiency of one set of blades. In these blades there is a drop in pressure on each set of blades whether they are movable or stationary. If there is the same amount of heat added on each set and if the velocity at entrance is the same into each set there will be the same velocity of exit. If for instance, α from the first set of fixed blades is equal to 20° and β of the movable blade is made equal to 75° , the value of w_b would be equal to

$$w_b = w_a \cos \alpha - \frac{w_a \sin \alpha}{\tan \beta} = w_a \left[\cos \alpha - \frac{\sin \alpha}{\tan \beta} \right]$$

Hence for any desired value of w_b , w_a could be found.

$$w_r = \frac{w_a \sin \alpha}{\sin \beta} \tag{73}$$

$$w'_r = fw_r = f \frac{w_a \sin \alpha}{\sin \beta} \tag{74}$$

If now it is desired to use an angle $180 - \beta' = \alpha$ for the angle of discharge and have the absolute direction of the jet at the angle $\alpha' = 180 - \beta = 105^\circ$, so that the same form of blades, although right and left handed, may be used for each stage, it will be necessary for

$$w'_r \text{ actual} = w_a.$$

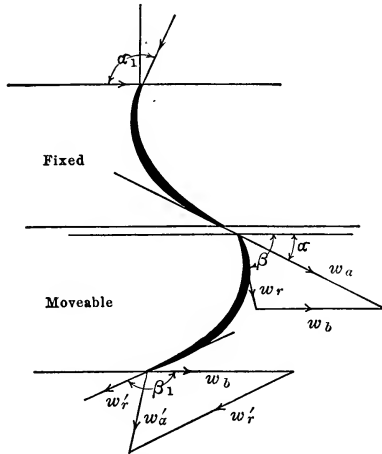

FIG. 160.—Blades of a Parsons turbine.

Hence w_r' above must be increased to w_a or

$$w_a = \sqrt{2gJ(i_1 - i_2)(1 - y) + \left(f \frac{w_a \sin \alpha}{\sin \beta} \right)^2} \tag{75}$$

$$w_a^2 = \frac{(223.7)^2}{1 - \left(\frac{f \sin \alpha}{\sin \beta} \right)^2} (i_1 - i_2)(1 - y)$$

$$i_1 - i_2 = \frac{w_a^2 \left[1 - \left(\frac{f \sin \alpha}{\sin \beta} \right)^2 \right]}{(1 - y)(223.7)^2} \tag{76}$$

Hence if α , β , and w_b are assumed, w_a and w_r may be found and from w_r , f may be selected, then $i_1 - i_2$ for the movable blade.

For the fixed blade the steam enters with the velocity

$$w'_a = \frac{w_r' \sin \alpha}{\sin \beta} = \frac{w_a \sin \alpha}{\sin \beta} = w_r$$

It leaves this fixed blade with the velocity w_a , the same as that of the first blade after being affected by friction and gaining kinetic energy from heat.

$$w_a = \sqrt{2gJ(i'_1 - i'_2)(1 - y) + \left(\frac{fw_a \sin \alpha}{\sin \beta}\right)^2}$$

$$i'_1 - i'_2 = \frac{w_a^2 \left[1 - \left(\frac{f \sin \alpha}{\sin \beta}\right)^2\right]}{(1 - y)(223.7)^2}$$

This does not give quite the same value as the first expression on account of the difference in f .

Now the work done on this stage per pound is

$$\text{work} = \frac{w_b}{g} [w_a \cos \alpha - w'_a \cos \alpha'] \quad (77)$$

$$= \frac{w_b}{g} w_a \cos \alpha \left[1 + \frac{\sin \alpha \cos \beta}{\sin \beta \cos \alpha}\right] \quad (78)$$

$$\text{The heat used is } i_1 - i_2 + i'_1 - i'_2 = Q \quad (79)$$

$$\text{Hence } \eta_s = \frac{A \frac{w_b}{g} w_a \cos \alpha \left[1 + \frac{\tan \alpha}{\tan \beta}\right]}{i_1 - i_2 + i'_1 - i'_2} \quad (80)$$

For the angles mentioned above and $w_b = 300$ ft. per second:

$$w_a = \frac{300}{0.94 - \frac{0.34}{3.73}} = \frac{300}{0.849} = 354$$

$$w_r = 354 \times \frac{0.34}{0.97} = 124$$

$$f = 1.00$$

$$i_1 - i_2 = \left(\frac{354}{223.7}\right)^2 \frac{\left(1 - \left[1.00 \times \frac{0.34}{0.966}\right]^2\right)}{1 - 0.04} = 2.30$$

f for the fixed blade is the same as the value used above, hence

$$i'_1 - i'_2 = 2.30$$

$$\begin{aligned} \text{Work per pound per stage} &= \frac{300 \times 354 \times 0.94}{32.16} \left[1 + \frac{0.36}{3.73} \right] \\ &= 3400 \text{ ft.-lbs.} \\ &= 4.38 \text{ B.t.u.} \end{aligned}$$

$$\text{Stage efficiency} = \frac{4.38}{4.60} = 0.95 = \eta_s$$

The reheat factor may now be applied in the usual manner for $\eta_s = 0.95$. This is, for the same pressures as before,

$$R.H. = \frac{0.311}{0.95 \times 0.324} = 1.013$$

Total heat available = $(1297 - 918) \times 1.013 = 384 \text{ B.t.u.}$

Total number of stages if velocities are the same on each = $\frac{384}{4.60} = 83$ stages.

This answer is not given in correct form as it is customary to enlarge the drum as the pressure falls. If the first drum is of diameter D_1 , the second is often made

$$D_2 = \sqrt{2} D_1$$

and

$$D_3 = \sqrt{2} D_2 = 2D_1$$

The speed will be proportional to the diameters and hence if the above is assumed for the middle portion

$$w_{b_1} = \frac{300}{\sqrt{2}} = 212$$

$$w_{b_3} = 300\sqrt{2} = 424$$

$$(i_1 - i_2) \text{ for first stage is } \frac{4.6}{2} = 2.3$$

$$(i_1 - i_2) \text{ for last stage is } 4.6 \times 2 = 9.2$$

$$\text{Stages in first portion} = \frac{379}{3 \times 2.3} = 55.$$

$$\text{Stages in second portion} = \frac{379}{3 \times 4.6} = 27.$$

$$\text{Stages in third portion} = \frac{379}{3 \times 9.2} = 14.$$

Total number = 96 stages. This is rather high. A common rule for the total number of stages is

$$\text{Number of stages} = \frac{2400000}{w_b^2} \quad (81)$$

In case above:

$$N_{first} = \frac{2400000}{(212)^2} = 54$$

$$N_{second} = \frac{2400000}{(300)^2} = 27$$

$$N_{third} = \frac{2400000}{(424)^2} = 14$$

The other quantities may be computed as shown in previous problems.

ALLOWANCE FOR CHANGE OF RUNNING CONDITIONS

Where turbines are actually tested and one condition is changed without changing other quantities the following allowances are found to hold:

From 0°–100° superheat, 10° F. **increase in superheat** decreases steam consumption 1 per cent.

From 100°–200° superheat, 12° F. **increase in superheat** decreases steam consumption 1 per cent.

From 200°–300° superheat, 14° F. **increase in superheat** decreases steam consumption 1 per cent.

For each 1 per cent. moisture the steam consumption will be increased 2 per cent.

For an increase in vacuum from 26 in. to 27 in. the steam consumption will decrease 5 per cent.

For an increase in vacuum from 27 in. to 28 in. the steam consumption will decrease 6 per cent.

For an increase in vacuum from 28 in. to 28½ in. the steam consumption will decrease 3.87 per cent.

For an increase in vacuum from 28½ in. to 29 in. the steam consumption will decrease 5.75 per cent.

For low-pressure turbines the following corrections may be made:

Increase in vacuum from 26 in. to 27 in. decreases steam consumption 12 per cent.

Increase in vacuum from 27 in. to 28 in. decreases steam consumption 13.75 per cent.

Increase in vacuum from 28 in. to 28½ in. decreases steam consumption 8.5 per cent.

Increase in vacuum from 28½ in. to 29 in. decreases steam consumption 11.25 per cent.

For pressure, the increase of pressure of 10 per cent. between 100 and 140 lbs. gauge pressure decreases steam consumption 2 per cent.

The increase of pressure of 10 per cent. between 140 and 180 lbs. gauge pressure decreases steam consumption 1.95 per cent.

The increase of pressure of 10 per cent. between 180 and 200 lbs. gauge pressure decreases steam consumption 1.90 per cent.

For low-pressure turbines 10 per cent. increase in pressure decreases the steam consumption 4 per cent.

In any case if the values of the theoretical thermal efficiency for two sets of conditions are computed the ratio of steam consumption may be assumed equal to the ratio of the efficiencies and the equivalent steam consumption thus found.

COMBINED ENGINE AND TURBINE

Since the turbine is of especial value for low pressures and high pressures lead to certain troubles, steam engines have been used to handle the steam first, after which the steam is exhausted into turbines for use at low pressures. The turbines using exhaust steam are known as **low-pressure turbines**. In these the exhaust steam, at atmospheric pressure from engines or other apparatus, is utilized by the turbine. This combination of engine and turbine has resulted in very low steam consumptions.

If the exhaust is not sufficient at times to drive the turbine, a set of blades is placed in the turbine on which high-pressure steam may be used in a high-pressure part in addition to the low-pressure steam. This is known as a **mixed flow turbine**.

TOPICS

Topic 1.—Derive the formula

$$w_2 = \sqrt{2gJ[(i_1 - i_2)(1 - y) + \frac{Aw_1^2}{2g}]}$$

What is y ? What is the meaning of i_2 in the above expression and what would it stand for if the bracket $(1 - y)$ were omitted? How is y found?

Topic 2.—Explain how the area F_x is found for different points of a nozzle with a uniform pressure drop. Explain why a throat exists. What is the critical pressure? Explain the terms: throat, mouth, over expansion, under expansion. What is the effect of the last two?

Topic 3.—Explain how the pressure in a tube at a given section may be found by experiment and how it may be calculated. Explain how this may be used to compute y . Sketch the form of apparatus used by Stodola and sketch the form of his curves.

Topic 4.—When are orifices or converging nozzles used? Sketch Rateau's forms. What fixes the length of a nozzle from entrance to throat and from throat to mouth? Give the steps taken in the design of a nozzle.

Topic 5.—Sketch and explain the action of an injector.

Topic 6.—Give the formulæ for the following velocities: (a) at the throat of a steam nozzle of an injector; (b) at the mouth of a steam nozzle of an injector; (c) at a point within the combining tube for the steam; (d) at a point within the combining tube for the water; (e) at the throat of the delivery tube; (f) after impact in the combining tube for the mixture.

Topic 7.—Write the two equations on which the action of the injector is based. What do these equations determine?

Topic 8.—Derive the formula for the delivery tube:

$$d_x = \frac{d_t}{\sqrt[4]{1 - \frac{x}{20d_t}}}$$

Topic 9.—Explain the action of a jet on a blade and prove the formulæ

$$P = \frac{mw}{g}$$

$$P = \frac{m}{g}(w_a \cos \alpha - w_b).$$

Topic 10.—Explain the action of a jet on a curved blade. Sketch the inflow and outflow triangles and prove that

$$\text{work per pound} = \frac{1}{g}(w_a \cos \alpha - w'_a \cos \alpha')w_b$$

What is meant by velocity of whirl? What are impulse and reaction turbines?

Topic 11.—Sketch the inflow and outflow triangles and give all resulting trigonometric relations.

Topic 12.—Deduce the condition for maximum efficiency when α is fixed and $\beta = 180 - \beta'$.

Topic 13.—Deduce the condition for maximum efficiency with a fixed value of β and β' .

Topic 14.—Explain the meaning of pressure compounding and velocity compounding. Explain the construction of a one-stage and two-stage velocity diagram with friction and without friction. Explain how to find the work and kinetic efficiency from this.

Topic 15.—Explain by diagrams the peculiar features of the turbines given in text. Sketch the curves showing the variation of pressure and velocity through the turbine.

Topic 16.—Give the expressions for the various component efficiencies of a turbine and the expression for the overall efficiency. Explain these and the method of computing them. Explain the similarity of thermal action of an engine and steam turbine.

Topic 17.—Sketch a Mollier chart and on it show why a reheat factor exists and derive the expressions

$$\begin{aligned} \tan \delta &= kT = \frac{i}{s} \\ \tan \gamma &= -\frac{\delta i}{\delta s} \\ R.H. &= \frac{1 - \left(\frac{T_d}{T_i}\right) \eta_s}{\eta_s \left(1 - \frac{T_d}{T_i}\right)} \end{aligned}$$

Topic 18.—Outline the method of design of a turbine to give a definite power.

PROBLEMS

Problem 1.—Find the velocity of discharge at throat and mouth of a nozzle operating with dry steam between 155 lbs. gauge pressure and 70 lbs. gauge pressure. Find the area of the nozzle to care for 30 lbs. of steam per minute.

Problem 2.—Draw a curve representing the change of area from 2 sq. in. to 0.25 sq. in. in 0.5 in. and then an enlargement to 2 sq. in. in 3 in. Find the pressure along this nozzle if the initial pressure is 135 lbs. absolute and the steam is superheated 230° F.

Problem 3.—Find the size and shape of a Rateau nozzle to deliver 2500 lbs. of steam per hour from a pressure of 25 lbs. gauge to a pressure of 15 lbs. gauge. $x_1 = 0.99$.

Problem 4.—Design an injector to feed 10,000 lbs. of water per hour into a boiler under a gauge pressure of 220 lbs. The lift is 5 ft. Make sketches of nozzle, combining tube and delivery tube.

Problem 5.—An injector operating with steam at 175 lbs. gauge pressure is to force water into a boiler in which the gauge pressure is 275 lbs. How much water is lifted per pound of steam?

Problem 6.—Prove that it is possible to feed a boiler under 120 lbs. gauge pressure by means of steam at 25 lbs. absolute pressure.

Problem 7.—Find the kinetic efficiency of a single-stage, impulse turbine with $\cos \alpha^{-1} = 0.93$ without friction and with friction. Find the efficiency if $\beta = 45^\circ$ and $\beta' = 135^\circ$.

$$w_a = 2700 \text{ ft. per sec.}$$

Problem 8.—Find the kinetic efficiency of a two-stage impulse turbine with $\cos \alpha^{-1} = 0.93$. Use no friction for first assumption. $w_a = 2700$ ft. per sec. Assume correct values of f to suit velocities and find the efficiency with friction.

Problem 9.—Solve Problem 8 assuming that $\alpha = \alpha_1$.

Problem 10.—Find the reheat factor for four stages on a Curtis turbine when $\eta_k = 0.75$, $\eta_n = 0.90$. The pressure range is from 175 lbs. gauge pressure, 100° F. superheat to 29 in. vacuum.

Problem 11. Find the pressure on the four stages of Problem 10 if the reheat factor is 1.03. What is the thermal efficiency? What are the various efficiencies? What is the probable steam consumption? Find leading dimensions.

Problem 12.—Find the reheat factor for a twenty-stage Rateau turbine with the same values of efficiency and range of pressure as that given in Problem 10.

Problem 13.—Determine the leading dimensions of a 200-kw. De-Laval turbine generator to operate between 150 lbs. gauge pressure and 2 lbs. gauge pressure. Give the probable steam consumption.

Problem 14.—Determine the leading dimensions, number of stages, reheat factor and probable steam consumption of a Parsons turbine to develop 3000 kw. with pressure of 175 lbs. gauge and 50° superheat to a 29-in. vacuum.

CHAPTER VIII

CONDENSERS, COOLING TOWERS AND EVAPORATORS

The condensers used in practice are of different forms. They are of the **surface form** when it is desired to use the condensate and the cooling water is improper for boiler feed. When the water used for cooling is satisfactory the **jet type** may be used.

Fig. 161 shows the usual form of **surface condenser**. In this steam enters at *A* and passes over the **tubes**, which are filled by water which enters at *B* and returns to *C* where it is discharged.

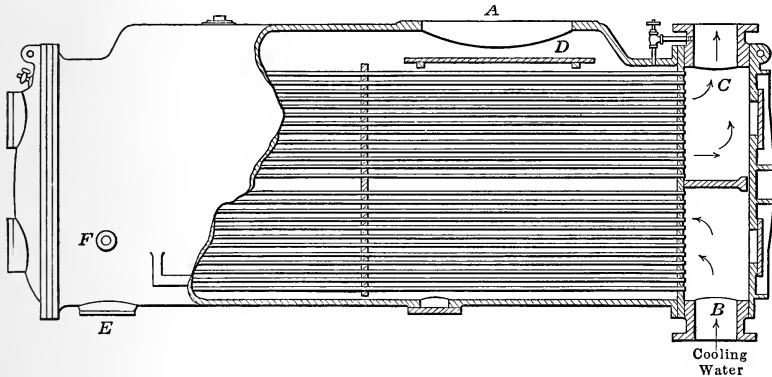

FIG. 161.—Surface condenser.

The **baffle plate** *D* is used to spread the steam over the surface of the tubes and prevent short circuiting. The condensed steam is drawn off at *E* and since the air entrained in the boiler feed would destroy the vacuum as it collects, means must be taken to remove this air. The pump which takes the condensate from this space of low pressure to the atmosphere is made sufficiently large to handle this air as well as the water and is therefore called an **air pump**.

The air present with the steam is a very small percentage of the mixture as it leaves the engine or turbine, but as the steam condenses the non-condensable air becomes a larger part of the remaining mixture of vapor and air. Air being heavier than

steam, the mixture containing the air naturally travels to the lower part of the condenser where if it is not removed fast enough it will so fill the space that steam cannot reach the condensing surface at this place and so the efficiency of the condenser is diminished.

Modern practice has demanded such low pressures in the condenser that a separate pump is necessary to remove the air alone from the bottom of the condenser at F while a small pump is used for the condensed steam at E . The air pump is then called a **dry air pump**, and by taking this air through a space cooled by tubes containing the coolest water available the volume of this air is decreased by the increase of air pressure due to the decrease of the vapor pressure.

PRESSURES IN A CONDENSER

If p_c is the **actual pressure** in the condenser shown by the vacuum gauge, this pressure is equal to the sum of the pressure due to **the steam** and that due to **the air**. Since the steam is in the presence of water, the steam pressure p_s is the saturation pressure corresponding to the temperature and the air pressure p_a is the difference of these.

$$p_a = p_c - p_s \quad (1)$$

The pressures p_a and p_s are known as **partial pressures**.

If now by passing this mixture of vapor and air through a cold space p_s is made smaller, the pressure p_a will be made so much greater that the volume of the air will be materially decreased. This requires a smaller air pump.

The pressure present in a condenser with no air corresponds to the saturation temperature, but as air is added this pressure rises, or for a given pressure the temperature of the mixture will be lowered as more and more air is permitted to enter.

The amount of **air present** has been the subject of much investigation. G. A. Orrok in the Transactions of the American Society of Mechanical Engineers, Vol. xxxiv, p. 713, etc., has shown that although Croton water contains 4.3 per cent. of air by volume, this is decreased to about 0.93 per cent. when heated in open heaters to 187° F.; 0.0151 per cent. of the 0.93 per cent. is air mechanically mixed and 0.916 per cent. is in solution. This air is referred to its volume at atmospheric pressure. Although the feed water contains 0.93 per cent. of air the water in the

hot well contains 0.269 per cent. of air, showing that for each cubic foot of feed water 0.00661 cu. ft. of air at atmospheric pressure had been liberated. At the low partial air pressure present in the modern condenser this is increased a hundredfold in volume. Mr. G. J. Foran in the discussion of this paper gives a curve from Castell-Evans Physico-Chemical tables showing the percentage absorption at different temperatures when the total pressure outside is 760 mm. This is given in Fig. 162. Although this does not agree with the values found by Orrok it shows how the solubility changes with the temperature.

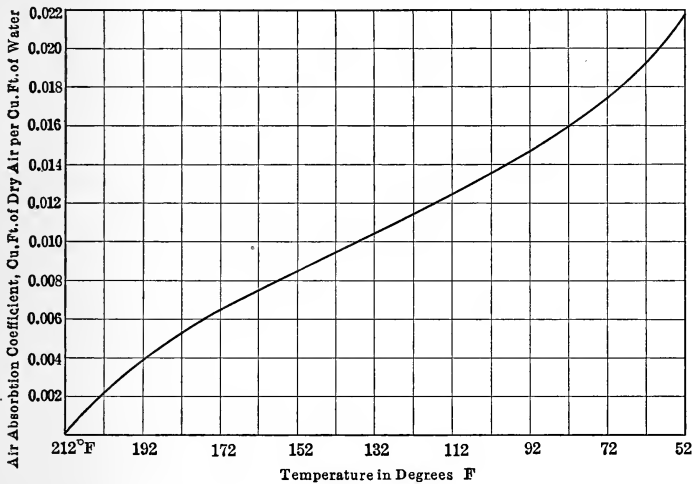

FIG. 162.—Amount of air at atmospheric pressure absorbed by 1 cu. ft. of water at various temperatures given by Foran from Winkler's data.

Orrok found that with turbine units of 5000 to 20,000 kw. the amount of air at atmospheric pressure and temperature varied from 1 cu. ft. per minute when the units were tight to 15 or 20 cu. ft. with ordinary leakage, and 40 to 50 cu. ft. per minute when the units were not tight. This shows that such air is due to leakage and not to the air contained in the feed water. The minute holes in the shells, heads and expansion joints are difficult to detect, but the saving from the elimination of these is much greater than the cost of that elimination. Although this leakage may amount to a considerable quantity, the shutting down of the air pump does not mean an immediate loss of vacuum. In a test mentioned by Mr. Foran a condenser caring for 9000 kw. lost only 0.3 in. in 30 minutes.

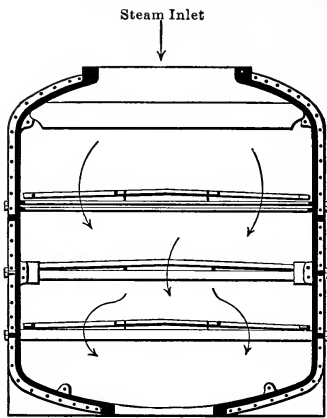

FIG. 163. — Shell and partitions of a Wheeler dry tube condenser.

Orrok found that there was too much drop of pressure in the condenser proper. To reduce this the condensers should be made broad and shallow. The drop amounted to about 0.2 in. of mercury, increasing with the load to 0.6 in. He found that the power required for the air pump condensers amounted to about 25 i.h.p. on the steam end for loads between 6000 and 10,000 kw. The mechanical efficiency of the dry air pumps was about 50 per cent. and the volumetric efficiency working between $\frac{1}{4}$ lb. and 15

lbs. was very low indeed, due partially to the low value of the clearance factor and to the large ratio of compression.

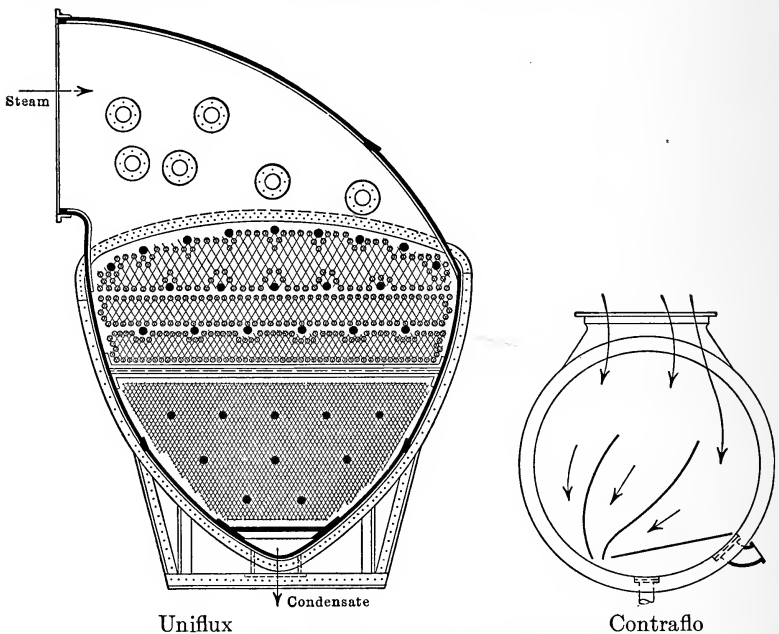

FIG. 164. — Sections of uniflux and contraflo condensers in which steam passages grow small as steam condenses.

During these tests the absolute pressure was about $1\frac{1}{2}$ in. of mercury and was obtained with 15° F. to 20° F. rise in the cooling

water at 35° F. The condensed steam was 10° above the temperature of the outlet water although the steam space might be 30° above this.

To better the cooling effect of the surface of condensers the velocities of the water and steam across the surface should be made high. This was explained in Chapter III.

The attempt has been made to keep the tubes partially dry from the drip of the condensate in the **Wheeler Dry Tube Condensers**, Fig. 163, by putting partitions across the condenser. The condenser tubes have been omitted from the figure so that the partitions may be shown clearer. This of course increases the velocity of the steam and so improves the heat transmission. This is a development of the English contraflow condenser. In **Weir's Uniflux Condenser**, Fig. 164, the shell is so made that the velocity of steam remains nearly constant as it is condensed and crosses the tubes. As the volume decreases, due to the condensation of part of the steam, the space through which the vapor passes gradually diminishes. The uniflux condenser shown at the left of Fig. 164 is almost an equivalent of the contraflow in a circular shell, the partitions of the contraflow guiding the steam into a channel of decreasing area.

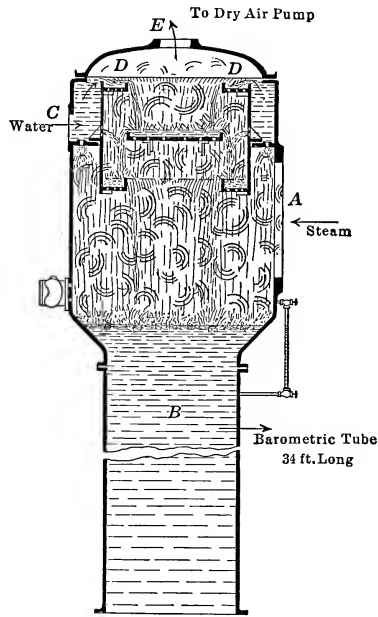

FIG. 165.—Barometric jet condenser.

When the condensing water is suitable for boiler feed or where it is not necessary to save the condensate, jet condensers are often used because they are cheap and may be effective. In them the water and steam are brought into intimate contact. Fig. 165 shows the type of jet condenser known as the **barometric counter-current condenser**

In this steam enters at *A* and meets the numerous streams of condensing water by which it is condensed, and falls to the tail

pipe *B* and finally discharges into the hot well. The cold water enters at *C* and discharges through numerous orifices into the highest trough *D* from which it discharges into the other troughs in succession. Air is removed by a dry air pump connected at *E* and all air has to pass through streams of the coolest water before leaving the condenser head. In this way p_s is made as small as possible, and p_a as great as possible.

CONDENSER DESIGN

The first point to be settled in the **design of a condenser** is the temperature of the cooling water and the vacuum desired. In most cases there will be a rise of about 20° in the cooling water, its outlet temperature will be 10° to 30° less than the temperature in the condensing space and the temperature of the hot well will be less than the temperature in the condenser by about 10° or 20° . A standard assumed by condenser designers for high vacuum work is a 15° rise in the cooling water and a temperature of outlet of 15° below the temperature corresponding to the vacuum carried. The greater the difference in temperature between the water and the steam, the more effective the surface will be. If then t_i , the inlet temperature, is known, t_o , the temperature at outlet, is assumed and finally t_s of the steam is assumed. From this p_s is known, and then if the amount of air present is known p_a may be computed and from it p_c , the condenser pressure expected on the condenser. The ratios of $\frac{p_s}{p_c}$ will be about 0.8 or 0.9. Knowing this, the amount of water per pound of steam is given by

$$G = \frac{i_o - q'_h}{q'_o - q'_i} \quad (2)$$

where G = pounds of cooling water per pound steam
 i_o = heat content of steam entering condenser
 q'_h = heat of liquid at temperature of hot well
 q'_o = heat of liquid at temperature of outlet
 q'_i = heat of liquid at temperature of inlet.

If this is a jet condenser

$$q'_h = q'_o \quad (3)$$

These may be taken within 5° of the temperature in the head.

After G is found the next calculation is that of the surface required for a given amount of steam. In practice $1\frac{1}{4}$ to 2 sq. ft. of surface are used per kilowatt.

If W is the weight of steam per kilowatt-hour output the total weight of water used will be

$$\text{total water per hr.} = G \times W \times \text{kw.} \quad (4)$$

The quantity of heat is

$$Q = G \times W \times \text{kw.} \times (q'_o - q'_i) \quad (5)$$

Using the formulæ of Chapter III for the surface the following results:

$$F = \frac{Q}{K \text{ mean } \Delta T} \quad \text{or} \quad \frac{Q}{\text{heat per sq. ft.}} \quad (6)$$

In computing the heat per square foot the velocity of the water may be taken as 4 ft. per second.

The tubes are arranged in nests so that the velocity of the water is that desired and then the spaces between the tubes are made to give a uniform velocity by means of the partitions.

After this the power and size of the water pump may be computed by assuming a pressure of say 5 lbs. for the resistance in the condenser tubes. The power and size of the air pumps are then found.

These various points will be brought out in the problems below.

PROBLEMS

Problem 1.—Suppose that 20 cu. ft. of air per minute are found to be present in the exhaust of a 10,000-kw. turbine. At a temperature of 75° in the condenser chamber and a pressure of 1 in. what would be the values of p_s and p_a ; and what would be the amount of air to be cared for by an air pump if the air is cooled to 60° F. before entering the cylinder? Steam per kilowatt hour = 14 lbs.

Steam pressure at $75^\circ = p_s = 0.4289$ lb. per sq. in.

Total pressure = $p_c = 0.49$ lb. per sq. in.

Partial air pressure = $p_c - p_s = 0.0611$ lb. per sq. in.

Steam pressure at $60^\circ = 0.2561$ lb. per sq. in.

Air pressure = 0.2339 lb. per sq. in.

It will be seen that by the cooling of this air the pressure has been increased fourfold.

$$\text{Volume of air per min.} = 20 \times \frac{15}{0.2339} = 1283 \text{ cu. ft.}$$

The pressure of the air in the dry air pump is raised from $\frac{1}{4}$ lb. to 15 lbs. and the clearance factor and leakage factor would be computed as in the case of the air compressors of Chapter IV.

$$\text{Displacement} = \frac{1283}{\text{clearance factor} \times \text{leakage factor}} \quad (7)$$

$$\text{I.h.p.} = \frac{n}{n-1} \frac{p_1 V_1}{\text{leakage factor}} \frac{\left(1 - \left(\frac{p_2}{p_1}\right)^{\frac{n-1}{n}}\right)}{33000} \quad (8)$$

Problem 2.—Find the amount of cooling water for the condenser of Problem I if the inlet water is at 50° F.

$$\begin{aligned} t_i &= 50^\circ \\ t_c &= 75^\circ \\ t_o &\text{ assumed } 65^\circ \\ t_h &= 55^\circ \end{aligned}$$

$$\text{Value of } i_{75} = 43.1 + 1049.2 \times 0.895 = 983.1$$

(0.895 was assumed from turbine problem in Chap. VII)

$$G = \frac{983.1 - 23.1}{33.1 - 18.1} = 64 \text{ lbs.}$$

Total weight water = $10,000 \times 14 \times 64 = 8,950,000$ lbs. per hr.

Total volume per minute = 2400 cu. ft. or 17,800 gal. per min.

Problem 3.—Find the surface required for the condenser above using admiralty tubing and assuming clean tubes with a water velocity of 4 ft. per second.

$$\Delta t_1 = 75 - 50 = 25$$

$$\Delta t_2 = 75 - 65 = 10$$

$$\text{Mean } \Delta t = \left[\frac{\frac{1}{8}(25-10)}{(25)^{\frac{1}{8}} - (10)^{\frac{1}{8}}} \right]^{\frac{8}{7}} = \left(\frac{1.875}{0.162} \right)^{\frac{8}{7}} = 16.4$$

$$K = \frac{630 \times 1.0 \times \left(\frac{0.43}{0.49}\right)^2 0.98 \sqrt{4}}{(16.4)^{\frac{1}{8}}} = 670$$

$$\text{Total heat per hr.} = 8,950,000 \times 15 = 670 \times F \times 16.4$$

$$F = 12,200 \text{ sq. ft.}$$

Increasing this 20 per cent. gives

$$F = 14,600 \text{ sq. ft. or } 1.46 \text{ sq. ft. per kw.}$$

In the N. Y. Edison Plants 1.1 sq. ft. are used per kilowatt in one of their new turbines. At the Interborough Station in New York 1.67 sq. ft. are used, and at the Fisk Street Station in Chicago 2.08 sq. ft. are used.

The cost of operating the auxiliaries of condensers amounts to $3\frac{1}{2}$ per cent. of the power of the engine or turbine, about $\frac{1}{2}$ per cent. being taken for the air pump and 3 per cent. for the circulating pump.

In the case of turbines a low vacuum can be used because the toe of the diagram is used, the expansion of the steam being of value to the lowest point. On account of the steam engine being unable to use the toe of the expansion diagram, due to the enormous volume required, the gain in power for part of the volume by decreasing the pressure is not enough to pay for the greater expense in operating the pump and the reduction in the temperature. This was explained in Chapter II.

COOLING TOWERS

Where cooling water is not obtainable as in the center of a large city and it is desired to operate the apparatus condensing,

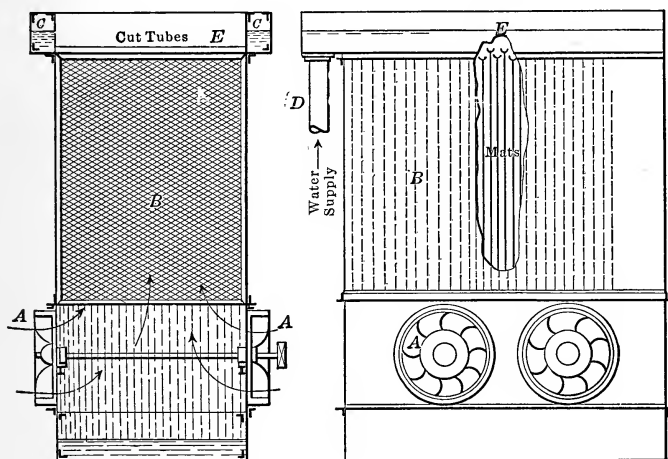

Fig. 166.—Cooling tower.

cooling towers are used. These are of different forms. In all of them air is allowed to come in contact with the warm condensing water which has been divided by some device into fine streams or sheets. In some cases the water is allowed to trickle over mats or screens of wire or is discharged over vitrified tiles by a distributing head. In other cases the water is discharged over boards. The general plan is to get the water into thin sheets or drops so as to expose a large area to the action of the air. To bring the air in contact with the water it is forced through by a fan or by a flue or chimney built on top of the tower to produce a draft by the warm air which sucks fresh air into the bottom of

the tower. This air becomes heated from the warm water and has its moisture content so increased that the evaporation of the water to satisfy this, added to the heat required to warm the air, so cools the water that it reaches the bottom of the tower at a temperature suitable for the condenser.

Fig. 166 illustrates one form of **tower**. The **fans A** are driven by an engine or motor and force the air through the **wire screens B**, called **mats**. The water enters the **troughs C-C** from the pipe **D** and is distributed into **tubes E** which have their upper part removed, forming troughs which overflow and distribute their water over the mats. By continuing the casing 30 or 40 ft. above the troughs there would be sufficient chimney effect to draw considerable air, although for maximum capacity fans are required. Cooling towers take about 5 per cent. of the power of the apparatus being operated by the condenser, 2 per cent. for the fan and 3 per cent. for circulating the water.

The amount of moisture that will be taken up by air depends on the amount of moisture present in the air. All liquids discharge particles into any space around them forming a vapor of the substance in the space above the liquid. Particles also fall back from the space into the liquid. The number of particles leaving the liquid is greater than the number falling back until the pressure exerted by this vapor is equal to the **vapor tension** or **saturated steam pressure** in the case of water, corresponding to the temperature of the liquid. At this time the space above is said to be **saturated** and the weight of vapor per cubic foot is the weight of a cubic foot of saturated vapor given in the tables. If the amount of moisture in the air is not equal to this, the air is not saturated with moisture and the ratio of the weight of moisture per cubic foot to the weight when saturated is called the **relative humidity**.

$$\rho = \frac{m_a}{m_s} \quad (9)$$

It happens that the ratio of the pressure exerted by this moisture compared with that at saturation is practically the same, since the pressure of a perfect gas is proportional to the mass when the volume and temperature are constant. Of course this is not a perfect gas and the statement is not absolutely true.

$$\rho = \frac{p_a}{p_s} \quad (10)$$

To find the relative humidity a **hygrometer** is used. The common form used in engineering work is that consisting of two thermometers, one of which has its bulb surrounded by a damp piece of wicking. As this is twirled at a high rate in the air the evaporation of the water on this bulb lowers its temperature, the amount of lowering being dependent on the relative humidity. The fall of temperature is then compared with the temperature of the dry bulb and the barometric reading; and from tables or formulæ the relative humidity is found.

Carrier proposes the formula

$$\rho = \frac{p'}{p_t} - \frac{\text{Bar.} - p'}{p_t} \times \frac{t - t'}{2755 - 1.28t'} \quad (11)$$

p' = pressure corresponding to wet bulb temperature

p_t = pressure corresponding to dry bulb temperature

Bar. = barometric pressure

t = temperature of dry bulb

t' = temperature of wet bulb.

If now the air enters the cooling tower at a temperature t_1 and of relative humidity ρ_1 the amount of moisture per cubic foot is

$$m_1\rho_1$$

where m_1 = weight of 1 cu. ft. of steam at temperature t_1 .

One cubic foot of entering air is considered in problems of the cooling tower as it leads to simple calculations.

If the temperature of the warm water is t_i , the temperature t_2 of the air leaving may be taken as 10 to 20° below t_i but saturated on account of the intimate mixture. The water leaving the tower will probably be above the temperature t_1 of the entering air although it might be equal to it in some cases. Assume t_1 to be 10° F. or 20° F. below the temperature t_o of the outlet water. With intimate mixture t_1 may correspond to t_o and t_2 to t_i .

The moisture per cubic foot leaving the tower is m_2 but the number of cubic feet have been changed on account of the changes of temperature and pressure. Let the weight of air be M .

$$M = \frac{(\text{bar.} - \rho_1 p_1)144V_1}{BT_1} = \frac{(\text{bar.} - p_2)144V_2}{BT_2} \quad (12)$$

Bar. = barometric pressure in lbs. per sq. in.

ρ_1 = relative humidity at 1

p_1 = saturation pressure at 1
 T_1 = absolute temperature at 1
 V_1 = volume at 1 = 1 cu. ft.

The volume of air at outlet corresponding to 1 cu. ft. at entrance is

$$V_2 = \frac{\text{bar.} - \rho_1 p_1}{\text{bar.} - p_2} \times \frac{T_2}{T_1} \quad (13)$$

The weight of moisture evaporated per cubic foot of original air is

$$m_e = m_2 V_2 - \rho_1 m_1 \quad (14)$$

If M_a = weight of cooling water cared for by 1 cu. ft. of air at entrance, the weight of water remaining is

$$M_a - m_e$$

The late Prof. H. W. Spangler solved this problem by equating energies at entrance and exit and hence it is necessary to find the energy brought in by each substance above 32° F.

I. Energy in water at bottom of tower above 32° F. =

$$(M_a - m_e) q'_o \quad (15)$$

II. Energy in air at entrance above 32° F. =

$$\frac{A(\text{bar.} - \rho_1 p_1) 144 \times 1}{1.4 - 1} - U_{32} \quad (16)$$

III. Energy in moisture entering above 32° F. =

$$\rho_1 m_1 [i_1 - A p_1 v'''] = \rho_1 m_1 i_1 - A p_1 \times 1 \quad (17)$$

i is heat content of superheated steam at pressure $\rho_1 p_1$ and of superheat of $t_1 - t_s$ degrees.

IV. Energy in water at top of tower above 32° F. = $M_a q'_i$ (18)

V. Energy in air at exit above 32° F. =

$$\frac{A(\text{bar.} - p_2) 144 V_2}{1.4 - 1} - U_{32} \quad (19)$$

VI. Energy in moisture leaving above 32° F. =

$$m_2 V_2 [q'_2 + r_2] - A p_2 V_2$$

or better

$$U = m_2 V_2 [q'_2 + \rho_2]. \quad (20)$$

VII. Work done by air in changing 1 cu. ft. to V_2 cu. ft. at barometric pressure =

$$A \text{ bar.} \times 144 \times (V_2 - 1) \quad (21)$$

Now the sum of the energies entering must equal the sum of those leaving plus the work:

$$\text{II} + \text{III} + \text{IV} = \text{I} + \text{V} + \text{VI} + \text{VII} \quad (22)$$

In this equation the only unknown is M_a and this may be found. From M_a the number of cubic feet of air required for a given installation may be known and from this the size of the fan, power required, size of tower and other data may be ascertained.

This is the best method for solving such a problem as other methods of attack are open to objections since the temperature at which events take place is not known.

PROBLEM

Suppose air at 70° gives a wet bulb temperature of 58.5° F. and is used in a cooling tower with hot water at 140° F. The barometer is 14.7 lbs. The air is so mixed that it leaves at 140° F. while the leaving water is cooled to 80° F. How much air would be required to cool 30,000 lbs. of water per hour.

$$p_{58.5} = 0.2428$$

$$p_{70} = 0.3627$$

$$\rho_1 = \frac{0.2428}{0.3627} - \frac{14.7 - 0.2428}{0.3627} \times \frac{70 - 58.5}{2755 - 1.28 \times 58.5}$$

$$= 0.668 - 0.171 = 0.497 = 0.5$$

$$m_1 = 0.001152$$

$$\rho_1 m_1 = 0.000576$$

$$m_2 = 0.00814$$

$$p_2 = 2.885$$

$$V_2 = \frac{14.7 - 0.5 \times 0.3627}{14.7 - 2.885} \times \frac{601}{531} = 1.39$$

$$m_2 V_2 = 0.00814 \times 1.39 = 0.0113$$

$$m_e = 0.0113 - 0.000576 = 0.0107$$

$$\text{Energy in water at bottom} = (M_a - 0.0107)48.1 = 48.1M_a - 0.515.$$

$$\text{Energy in air at entrance} = \frac{1}{778} \frac{(14.7 - 0.1814)144}{0.4} - U_{32} = 6.70 - U_{32}.$$

$$\text{Energy in moisture} = 0.000576 [19.1 + 1061.8 + 19 \times 0.43] - \left[\frac{1}{778} \times 0.1814 \times 144 \right] = 0.600.$$

(Moisture at entrance is under a pressure of 0.1814 lb. and at a temperature of 70° . 0.1814 lb. means a saturation temperature of 51° or the moisture is 19° superheated. From the curves of specific heats in Chapter I, c_p is 0.43.)

Energy in water at top of tower = $M_a \times 108.0$.

Energy in air at top = $\frac{1}{778} \frac{[14.7 - 2.885]144 \times 1.4}{0.4} - U_{32} = 7.65 - U_{32}$.

Energy in moisture at top = $0.0113[108.0 + 947.5] = 11.9$.

Work done by changing 1 cu. ft. of volume to 1.4 cu. ft. of volume at atmospheric pressure = $\frac{1}{778} \times 14.7 \times 144(1.4 - 1) = 1.09$.

$$6.70 - U_{32} + 0.600 + M_a \times 108.0 = 48.1M_a - 0.515 + 7.65 - U_{32} + 11.9 + 1.09$$

$$M_a = \frac{12.82}{59.9} = 0.214$$

This is the amount of water cared for by 1 cu. ft. of air at entrance, the reciprocal, 4.7 cu. ft., being the number of cubic feet of air required to care for 1 lb. of hot water. The amount of water evaporated per cubic foot of air has been found to be 0.0107 lb. This quantity is 5.2 per cent. of the water supplied (0.214 lb.) per cubic foot of air.

In the problem 30,000 lbs. of water are passed through the cooling tower. This requires $4.7 \times 30,000$ or 141,000 cu. ft. of air per hour. The evaporation will amount to 5.2 per cent. of the weight of water or 1600 lbs. of water per hour. Had this cooling tower been supplied with water at a lower temperature the evaporation would have been much less but the amount of air would be greater. With the temperature of the condensing water from a condenser at 140° F. (this temperature is much higher than that found in practice) with a supply temperature of 80° F., 16 lbs. of water would be required per pound of steam so that 30,000 lbs. of water would be used with 1880 lbs. of steam. If this condensed steam were used in a cooling tower it would more than care for the loss by evaporation and if used for boiler feed, the make-up water to be bought would be less than the feed water saved. In all cases where the condensate can be used either for boiler feed or condensing water the cooling tower reduces the bill for water. If the water cannot be used it will be found in most cases that the sum of the make-up water and feed water will be less than the steam necessary with a non-condensing plant. In all cases the heating of the air and the doing of external work makes the amount of evaporation in the tower less than the amount of condensation cared for by the cooling apparatus.

It will be well to keep in mind that although the air entering the lower part of the cooling tower be saturated with moisture, due to rain or snow, the greater moisture content for the warm

air makes evaporation possible even in this case. The warming of the air also removes heat and cools the water.

SIZE OF TOWER AND MATS

The size of the tower necessary to be used may be found by assuming the air to pass through at a velocity of 700 ft. per minute and the area of the mats or cooling surface may be found by allowing 200 B.t.u. per hour per square foot of surface with 10° cooling to 700 B.t.u. per hour per square foot with 35° cooling. This may sometimes be expressed in terms of the water, 1 sq. ft. for 25 lbs. of water per hour. This is independent of the amount of temperature change.

For the problem above the net area of the horizontal cross section of the tower would be

$$F_n = \frac{141000}{60 \times 700} = 3.36 \text{ sq. ft.}$$

The area of the mats would be

$$F_m = \frac{30000(140 - 80)}{1000^*} = 1800 \text{ sq. ft.}$$

* This is assumed for the large drop of 60° F.

$$F_m = \frac{30000}{25} = 1200 \text{ sq. ft.}$$

In planning this tower care should be taken to prevent the water from falling free. It must be kept in contact with the mats. There must be care in arranging the passages to prevent air from taking any path which does not bring it into contact with the water.

Towers cost from \$1.00 to \$6.00 per kilowatt capacity or as much in some cases as the condenser equipment.

The power to drive the fan is about 2 to 5 per cent. of the engine power. In the case above the practical use of the fan is to give velocity only, as the drop in pressure is practically nothing. For this reason the formula for the power of the fan need only consider the kinetic energy of the air, the friction head being considered as equal to the velocity. This gives

$$\begin{aligned} \text{work per minute} &= 2 \times \frac{141,000 \times 14.7 \times 144}{60 \times 53.35 \times 531} \left(\frac{700}{60}\right)^2 \frac{1}{64.4} \\ &= 750 \text{ ft.-lbs. per min.} \end{aligned}$$

SPRAY NOZZLES AND PONDS

Another device often used to cool water is the **spray fountain**. Nozzles are supplied with hot water from a main and the velocity of discharge is made to divide it into a fine spray. The water is then caught in a reservoir from which it is taken to the condenser. With these nozzles the water may be cooled 15° when the atmosphere is 25° to 30° below the temperature of the hot water while 20° may be obtained with a 40° difference. These nozzles are placed about 8 ft. apart and are usually fitted to 3-in. pipes in which the velocity should be about 5 ft. per second. In this way each nozzle will care for about 60,000 lbs. of water per hour.

In some plants large **cooling ponds** are used to cool the water by surface evaporation. With these the hot water is discharged at one end of the pond and the cooling water is taken off at the other. Thomas Box, many years ago, recommended that 210 sq. ft. of cooling surface be used per nominal horsepower if the engine was operated for 24 hr. per day. This was with engines using more steam than those of to-day and this might be reduced to say 120 sq. ft. per 24 h.p.-hr. per day, or about 5 sq. ft. per horse-power hour during the day of 24 hr. W. B. Ruggles, in the Journal of the A.S.M.E. for April, 1912, gave a test of a cooling pond of 288,000 sq. ft. of a depth of 5.38 ft. in which he found a transfer of 3.67 B.t.u. per square foot of water surface per hour per degree difference in temperature between air and water, and that 120 sq. ft. of surface per horse-power was sufficient when 16 lbs. of steam were used per horse-power hour.

ACCUMULATORS AND EVAPORATORS

Regenerator accumulators are devices used for the retention of surplus heat until needed when an intermittent supply is given off by a machine and it is desired to use this in another piece of apparatus. They were planned by Rateau to be used with low-pressure turbines which were operated by the exhaust steam from engines, the operation of which was intermittent as is the case with rolling mill engines or from steam hammers. One of his forms is shown in Fig. 167. It consists of a vessel A made of steel in which there is a horizontal partition at the center.

A number of elliptical flues *B.B.* are placed in the tank. These receive steam from the pipe *D* and manifold *C* and steam is discharged through $\frac{3}{4}$ -in. holes in the flue walls into the water carried in the chambers. This water may enter the flues. The steam heats the water which is introduced from the float box *E* as soon as the water level is lowered. The steam entering from *D* may also enter the top of the accumulator by the check *G* and pass out to the turbine through *F*. If however the intermittent supply is reduced or stopped momentarily, the pressure in the accumulator falls and the warm water begins to evaporate, thus maintaining the steam supply. Of course if the supply of steam is discontinued for a long time, the turbine receives its steam through a reducing pressure valve from the boiler main. Baffle plates are used above the elliptical steam flues to cause the water and steam to mix and to dry out the steam leaving the accu-

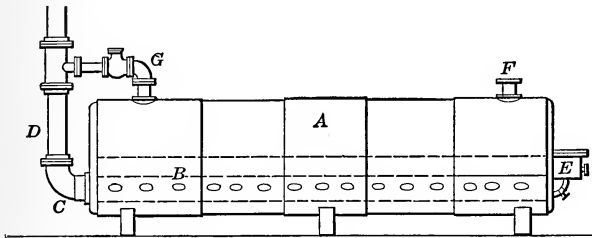

FIG. 167.—Rateau accumulator.

mulator. In some Rateau Accumulators large masses of iron in the form of trays are used to absorb the heat and supply that necessary to evaporate the water when the supply is reduced.

Evaporators are used for the purpose of concentrating liquors or solutions and for the production of distilled water or other liquid although when used for this latter purpose they are known as stills. Fig. 168 shows one form of evaporator. In this one a liquid to be evaporated is carried to the line *A* in a tank *B* containing a set of tubes *C* held between two tube plates. The space *D* between the tube plates is separated from the remainder of the shell. This space is supplied with steam or some other hot vapor. The vapor gives up its heat to the fluid within the tubes and is condensed, the condensate leaving at *E*. If the pressure in the chamber above the level of the liquid is such that the boiling temperature of the liquid is below the temperature of the vapor entering the space *D* from the pipe *F*, the liquid will boil and its

vapor may be used to boil liquid in a second chamber in which the pressure is maintained still lower than that in the first chamber. This operation may be repeated as shown in the figure, the vapor from the last chamber B'' passing to the condenser H in which the pressure is maintained at a low point by the air pump I . In many cases where these are used for the concentration of liquors as in sugar making, the dilute solution enters at J and as it becomes more concentrated it sinks to the bottom of B and is passed over to the upper level of K' of the next evaporator. Since the pressure is lower in C than in B this action will take place and be regulated by opening a valve in the line. This action is carried on throughout the system.

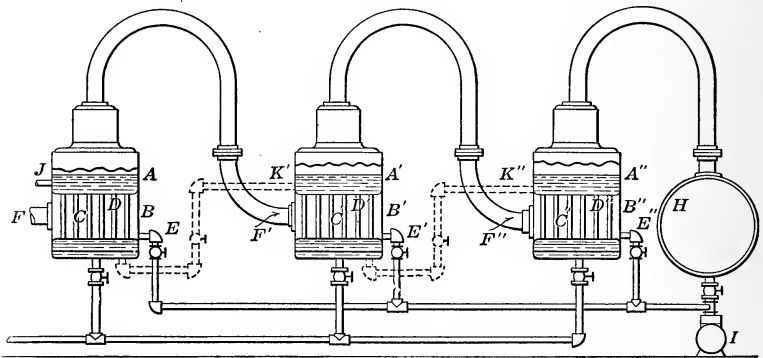

FIG. 168.—Triple effect evaporator.

Where three of these are used as shown in Fig. 168, the arrangement is known as a **triple effect** evaporator, a single one as a **single effect**, two as a **double effect**, four as a **quadruple effect**.

Assuming the arrangement as shown, suppose M pounds of liquor enter at J . Of this e_1 pounds are evaporated and $M - e_1$ pounds pass on to the second effect to be evaporated. Of this e_2 are evaporated and $M - (e_1 + e_2)$ are passed on and e_3 are evaporated and $M - (e_1 + e_2 + e_3)$ are drawn off as a concentrated solution.

In the first effect suppose 1 lb. of vapor is admitted at F . This is condensed and the condensate is removed at E . This weighs 1 lb. e_1 pounds of vapor are admitted to F' and e_1 pounds of vapor are condensed here. e_2 pounds are introduced and condensed in the third stage.

In working out the condensation and evaporation in the differ-

ent effects the method of procedure is to start with the one effect and work to the others. In these various tanks the amount of heat loss must be allowed for and if the size of the tanks be assumed the amount of heat loss per hour may be computed for each from the value K for coverings as given in Chapter III. The pressures in the various tanks are assumed so as to give the proper temperature differences. These may be made 20° for each stage.

The condensates from the various stills could be discharged through a feed heater and this heat could be added to the feed entering the first effect so that the condensates would leave at the temperature of the fresh liquid. The same could be done in theory with the condensate from the condenser. The operation of the triple effect depends on a difference in the temperatures of the various effects and hence in any problem the initial steam pressure p_1 and temperature t_1 and the final temperature t_c would be assumed and with them the various intermediate temperatures, from the temperatures of the condenser and the temperature of the condensate. For a triple effect, the temperature of the steam in the first effect is t_1 in the supply and t_2 in the discharge while t_3 is the temperature of the discharge from the second and t_c is the temperature of the discharge from the last stage. The temperature of the cooling water and weak liquor is t_i and that of the warm circulating water is t_o while the condensate in the condenser is t_h . The following conditions hold for the various stages if 10 per cent. of the heat entering is assumed to be lost in radiation.

First Stage—Heat Entering:

$$\text{With 1 lb. steam } Q = q'_1 + r_1 \quad (23)$$

$$\begin{aligned} \text{With } e_1 + e_2 + e_3 \text{ lbs. feed } Q &= (e_1 + e_2 + e_3)q'_i \\ &+ 1(q'_1 - q'_i) + e_1(q'_2 - q'_i) + e_2(q'_3 - q'_i) + \\ &e_3(q'_h - q'_i). \end{aligned} \quad (24)$$

(Feed heaters are used to reduce condensates to t_i)

Heat Leaving:

$$\text{With } e_1 \text{ lbs. evaporation } Q = e_1(q'_2 + r_2) \quad (25)$$

$$\text{With } e_2 + e_3 \text{ lbs. feed to next evaporator } Q = (e_2 + e_3)q'_2 \quad (26)$$

$$\text{With radiation } Q = \frac{1}{10}(q'_1 + r_1) \quad (27)$$

$$\text{With 1 lb. condensate } Q = q'_1 \quad (28)$$

The equation for heat balance is

$$q'_1 + r_1 + q'_1 - q'_i + e_1q'_2 + e_2q'_3 + e_3q'_h = q'_1 + \frac{1}{10}(q'_1 + r_1) + e_1(q'_2 + r_2) + (e_2 + e_3)q'_2$$

$$0.9(q'_1 + r_1) - q'_i = e_1r_2 + e_2(q'_2 - q'_3) + e_3(q'_2 - q'_h) \quad (29)$$

The equation for the second stage in the same manner is

$$0 = e_1[0.9r_2 - 0.1q'_2] - e_2[q'_3 + r_3 - q'_2] - e_3[q'_3 - q'_2] \quad (30)$$

The third stage gives

$$0 = e_2[0.9r_3 - 0.1q'_3] - e_3[q'_c + r_c - q'_3] - m_oq'_c \quad (31)$$

These three equations are sufficient to find the quantities e_1 , e_2 and e_3 .

In the last effect the final withdrawal of the concentrated liquor will give the subtractive term in the last equation:

$$m_oq'_c \quad (32)$$

m_o is very small compared with the other terms.

PROBLEM

As a problem, suppose water at 65° F. is to be distilled in a triple effect with steam at 228° F. with 10 per cent. loss. Suppose the temperatures of boiling are 208°, 188° and 168° and that the temperature of the outlet water from the condenser is 85° and the hot well is 90° F. The equations above then become

$$0.9 [196.5 + 959.4] - 33.1 = e_1(972.2) + e_2(176.2 - 156.1) + e_3(176.2 - 58.1)$$

$$0 = e_1[0.9 \times 972.2 - 0.1 \times 176.2] - e_2[156.1 + 984.7 - 176.2] + e_3 [176.2 - 156.1]$$

$$0 = e_2[0.9 \times 984.7 - 0.1 \times 156.1] - e_3[136.0 + 996.7 - 156.1]$$

$$1007.3 = 972.2e_1 + 20.1e_2 + 118.1e_3$$

$$0 = 857e_1 - 964.6e_2 + 20.1e_3$$

$$0 = 870.7e_2 - 976.6e_3$$

$$e_2 = 1.12e_3 = 0.84$$

$$e_1 = 1.21e_3 = 0.93$$

$$e_3 = 0.75$$

The weight of condensate = 3.52 lbs.

The amount of water used in the condenser per pound of steam in the first evaporation is

$$M = \frac{0.75 [136.0 + 996.7 - 58.1]}{20} = 40.3 \text{ lbs.}$$

The amounts of heat can now be computed for each evaporator when the total amount of evaporation is known. If this amount is M , $\frac{M}{3.52}$ is the

amount of steam condensed in the first stage, $\frac{0.93}{3.52} M$ is condensed in the second stage, $\frac{0.84}{3.52} M$ is used on the third and $\frac{0.75}{3.52} M$ is condensed in the condenser. By using the methods of this chapter or Chapter III, the surface required for this heat under the conditions given can be determined.

The loss of heat from the surface of the evaporators can be computed by the methods of Chapter III, when the actual size and shape is known with the temperatures. This would give a definite number of heat units instead of the percentage. Its use would be the same as above.

At times the supply for each evaporator is taken from the weak liquor line and then the terms

$$(e_2 + e_3) q'_2$$

$$e_3 q'_3$$

will be omitted from the equation. Each stage will have the weight evaporated in that stage as the unknown in the equation. The feed might be heated by the outgoing condensate or if not an assumption of its temperature would be made.

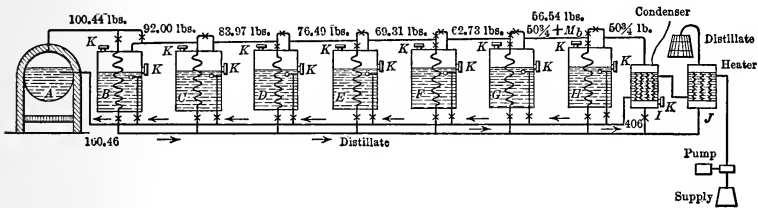

FIG. 169.—Hodge's multiple still.

To remove the air which may collect in the various condensing chambers, air pumps must be attached or small vent holes must be made from the condensing chamber to the boiling chamber.

Another multiple effect known as **Hodge's Multiple Still** is shown in Fig. 169. In this *A* is the boiler and *B*, *C*, *D*, *E*, *F*, *G* and *H* are **evaporators** or **stills**. Steam from the boiler is passed into still *B* to evaporate its amount *M* of the liquid and enough steam is added to the steam exhausted from one still from the boiler steam to give sufficient heat to condense the same quantity *M* in the next still and to make up for the radiation and the steam lost by the blow-off from the valves *K*. The blow-off is intended to remove the air from

the evaporator. *I* is a **condenser** and *J* is a **feed-water heater** to reduce the temperature of the condensate. The feed to each still is controlled by a float valve and this feed together with the boiler feed is carried through the same line. Since the water used in the condenser is sufficient to feed the boiler and stills, its amount is limited. Since in addition to this the maximum possible temperature leaving the condenser is fixed by the pressure of the steam to be condensed, the temperature entering the condenser is fixed and hence this water might not be sufficient to cool the condensate in the feed-water heater to a low value. The extra cooling water is required to reduce the temperature of the condensate still lower. Although not used in the Hodge's Multiple Still, a feed heater on the outlet of the condensate from each still would increase the efficiency if the feed to that still were passed through it.

To design such a still the desired amount of distillation, or the capacity, and the pressures and temperatures would be assumed. The total capacity would be divided equally among the stills and the condenser; in the above figure among eight units. From the amount of water to be evaporated or condensed, together with the temperature difference, the probable size of each unit is found. From the size and temperature the amount of heat lost may be computed. The problems are now solvable since equations for each still may be written out as soon as the amount of blow is assumed.

PROBLEM

Suppose 400 lbs. of distilled water are desired per hour and from the size of still required to condense $\frac{3}{8} \times 400$ lb. or 50 lbs. the radiation is 4000 B.t.u. per hour and that $\frac{3}{4}$ lb. of steam blown per hour would be sufficient to keep the evaporator clear of air.

The temperature drop in each unit will be taken as 10° and since the pressure even in the condenser is to be above the atmosphere its temperature must be above 212° F. Suppose this is taken as 220° F., then the temperatures of the various stills will be 220° , 230° , 240° , 250° , 260° , 270° and 280° . The temperature of the boiler steam will be 290° F. The absolute pressure will therefore be 17.2 lbs., 20.8 lbs., 25.0 lbs., 29.8 lbs., 35.4 lbs., 41.8 lbs., 49.2 lbs. and 57.5 lbs.

The amount of steam and water leaving the apparatus is

$$8 \times 50 + 8 \times \frac{3}{4} = 406 \text{ lbs.}$$

This must be the total feed.

The temperature of the condensing water leaving the condenser would be

210° F. if the same temperature difference is to be used here. The feed water entering any still is at this temperature.

The equation for the condenser is

$$406q'_i + 50\frac{3}{4}(q'_{220} + r_{220}) = \frac{3}{4}(q'_{220} + r_{220}) + 50q'_{220} + 406q'_{210} + 4000 \quad (33)$$

$$q'_i = 69.0$$

$$t_i = 101^\circ$$

The equation for *H* is

$$(50\frac{3}{4} + M_b)(q'_{230} + r_{230}) + M_f q'_{210} = 50q'_{230} + 50\frac{3}{4}(q'_{220} + r_{220}) + \frac{3}{4}(q'_{230} + r_{230}) + 4000 \quad (34)$$

$$50\frac{3}{4} + M_b + M_f = 50\frac{3}{4} + 50 + \frac{3}{4} \quad (35)$$

$$M_b + M_f = 50\frac{3}{4} \quad (36)$$

$$M_b = 5.79 \quad (37)$$

$$M_f = 44.96 \quad (38)$$

The equation for *G* will be

$$(56.54 + M_b)(q'_{240} + r_{240}) + M_f q'_{210} = 50q'_{240} + 56.54(q'_{230} + r_{230}) + \frac{3}{4}(q'_{240} + r_{240}) + 4000 \quad (39)$$

$$56.54 + M_b + M_f = 50 + 56.54 + \frac{3}{4}$$

$$M_b + M_f = 50\frac{3}{4}$$

$$M_b = 6.41$$

$$M_f = 44.34$$

The amounts for the stages are as follows:

	<i>M_b</i>	<i>M_f</i>
Stage <i>B</i>	8.44	42.31
Stage <i>C</i>	8.03	43.00
Stage <i>D</i>	7.48	42.98
Stage <i>E</i>	7.18	43.48
Stage <i>F</i>	6.58	44.11
Stage <i>G</i>	6.19	44.70
Stage <i>H</i>	5.79	44.96
Condenser	50.75

Feed to boiler 100.44 Feed to tank 305.56

Total feed = 406 lbs.

The amount of evaporation per pound of steam is $\frac{406}{100.44} = 4.05$. A result that is only a little better than could be obtained with an ordinary quintuple effect.

The temperature of the distillate is found by adding together the heats of the liquid for each discharge and then dividing this by eight to get the average heat of the liquid. This is true because each evaporator sends 50 lbs. into the distillate line. This gives

$$q'_m = 223.9$$

$$t_m = 255^\circ.1$$

The temperature of the water entering the condenser will have to be 101° so that the heat necessary to raise this water from 65° F. will reduce the temperature of the distillate

$$\frac{406(101 - 65)}{400} = 36.3^{\circ} \text{ F.}$$

or to 218.8° F. To cool this off still more cold water is circulated in the cooler. If the distillate is desired to be cooled to 80° F. the amount of water needed would be

$$M = \frac{400 [218.8 - 80]}{80 - 65} = 3690 \text{ lbs.}$$

This heat could be saved by arranging the distillate to warm the feed at each still.

DOUBLE BOTTOMS

The design of **double bottoms** for evaporation of liquors is carried out in the manner of Chapter III. The temperature of boiling of the liquor may be fixed by the pressure and found from a table or if the temperature is given the pressure may be found in tables. If the tables are not at hand recourse may be had to the rule of Dühring as given by Hausbrand:

TEMPERATURE OF BOILING

The difference between the boiling temperatures of a liquid at any two pressures is equal to a constant multiplied by the difference in temperatures of water at the same pressures. The values of the constants are given for some substances in the table below:

Water	1.0
Alcohol	0.904
Ether	1.0
Acetic acid	1.164
Benzene	1.125
Turpentine	1.329
Mercury	2.0
Carbolic acid	1.20

If one temperature and pressure is known for a substance another may be found. Thus if mercury boils at 674° F. at atmospheric pressure it is desired to find at what pressure it would boil at 400° F. Water at atmospheric pressure boils at 212° F. The temperature for water corresponding to mercury at 400° F. is given by:

$$674 - 400 = 2 (212 - t_x)$$

Since the constant in the table is 2.

$$t_x = 75^\circ.$$

$$\text{Pressure} = 0.42 \text{ lbs. per sq. in.}$$

Having the temperature required, the temperature difference may be found or assumed and then if the heat of vaporization is found by reference to tables the area may be found by

$$F = \frac{Q}{K\Delta T} \quad (40)$$

Where $k = 1600$ for water.

$k = 1200$ for thin liquors.

$k = 500\text{--}900$ for thick liquors.

TOPICS

Topic 1.—What is the purpose of the dry air pump? Why is the air for this pump brought into contact with the coldest water? Explain clearly. On what does the amount of air depend? What are the peculiar features of the Wheeler dry tube condenser, the uniflux and the contraflo condenser? What is the reason for the use of the barometric condenser?

Topic 2.—Outline the method of design for all parts of a condenser.

Topic 3.—Sketch and explain action of a cooling tower and derive equation for the determination of the amount of water cooled per cubic foot of air taken in. Give the expressions for computing each term of the equation.

Topic 4.—Explain the action of spray nozzles, ponds, and accumulators and show how to find size of each to perform a given service.

Topic 5.—Sketch and explain action of a triple effect. Write formulæ for the determination of the evaporation per pound of steam supplied to the first effect.

Topic 6.—Sketch and explain action of Hodge's multiple still. Write equations for the condenser and the next two stills by which the quantity of steam may be found.

Topic 7.—Explain how to find the temperature at which a substance will boil under a certain pressure if the temperature is known for a given pressure. What are double bottoms? How are they designed?

PROBLEMS

Problem 1.—An air pump is used with a 10,000-kw. turbine. The temperature of the hot well is 65° F. The vacuum carried is 29 in. How much air is present? If the air and vapor are carried around cold water pipes so that the temperature is reduced to 50° F., how much has the volume of air been reduced? Is the air leakage in this condenser system excessive?

Problem 2.—Find the amount of surface to use with a 10,000-kw. turbine with a steam consumption of 13 lbs. of steam with a vacuum of 29 in. and temperature of steam of 65° F. if the cooling water operates from 45° F. to

60° F. How much water is required? How many $\frac{3}{4}$ -in. tubes would be used in a nest?

Problem 3.—Find the amount of air to cool 3,900,000 lbs. of water per hour from 110° F. to 80° F. in 70° F. weather with the barometer at 29.6 in. and the wet bulb at 60° F.

Problem 4.—How many spray nozzles would be required for Problem 3? How large a cooling pond would be required?

Problem 5.—Compute the amount of distilled water made per pound of steam from a triple effect heated by exhaust steam at 3 lbs. gauge pressure if the condensed steam in the first effect is of no value. x of the entering exhaust steam is 0.90. Temperature of water supply is 60° F. Vacuum allowed on condenser, 20 in.

Problem 6.—Find the pressure at which mercury will boil at 300° F.

Find the area required for a double bottom to drive off 700 lbs. of water per hour from a solution at 15 in. vacuum. Neglect heat of solution.

CHAPTER IX

INTERNAL COMBUSTION ENGINES AND COMBUSTION

The **internal combustion engine** has been greatly improved within the last 25 years although its history extends back several centuries. In 1680 Huygens, a Dutch physicist, proposed to use the explosion of gun powder to drive the piston and in 1690 Papin continued this work. There is nothing definite known of their work or similar proposals by Abbé Hautefeuille at about this date. In 1794 a patent was granted to Robert Street for a gas engine using turpentine in the bottom of a heated cylinder and the mixture of this with air was ignited by a flame. Samuel Brown originated an engine in 1823-6 in which a soluble gas behind a piston was dissolved in water and thus produced a vacuum sucking the piston downward. The Wright engine in 1833 exploded a mixture of compressed gas and air which was admitted to the cylinder after the exploded gases were driven out. This engine required two revolutions, or four strokes to the cycle. The Barnett engine of 1837 used a separate pump to compress the air. In the years 1838 to 1854 there were eleven English patents for gas engines applied for. In 1855 the method of igniting the charge by compressing it into a heated tube was patented by A. V. Newton and in 1857 Barsanti and Matteucci invented an engine with a free piston in which the explosion of gas drove the piston upward and the contraction due to cooling produced a reduction of pressure so that the piston was drawn back by this and its weight, and acted on the crank shaft through a ratchet.

The history of successful gas engines begins with 1860 when **Lenoir** built his machine. This resembled a steam engine in structure and action. A mixture of gas and air was drawn into a cylinder by the movement of a piston from the fly wheel and after the piston had reached the middle of its stroke the gas and air were shut off and the mixture was exploded by a high-tension spark between two platinum points. The pressure immediately rose and as the piston moved forward this gas expanded reaching atmospheric pressure at the end of the stroke. On the return stroke, the same thing occurred on the other side

of the piston, the exploded gases on the first side being exhausted. The cycle of this engine is shown by the card of Fig. 170.

In 1863 **M. Alph. Beau de Rochas** published a pamphlet in which he suggested that the greatest economy of the gas engine would be obtained if:

1st. The greatest possible cylinder volume with the least possible surface be used.

2nd. If the expansion be as rapid as possible.

3rd. If the expansion be as complete as possible.

4th. If the explosion pressure be as large as possible.

He then follows this by a description of a cycle to give these results. The cycle consists of:

1st. **Suction** on entire stroke.

2nd. **Compression** on second or return stroke.

3rd. **Ignition** at dead point and expansion on third stroke.

4th. **Exhaust** of gases on fourth stroke.

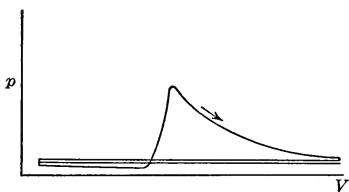

FIG. 170.—Card of the Lenoir cycle.

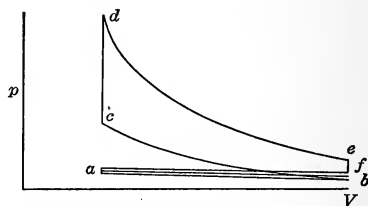

FIG. 171.—Card of the Beau de Rochas or Otto cycle.

This cycle was to have ignition due to high compression.

In 1867 **Otto** and **Langen** exhibited their first engine at the Paris Exposition. This was similar to that of Barsanti but it was a practical machine although very noisy. While Lenoir's engine took over 90 cu. ft. of gas per boiler brake-horse-power hour this engine consumed only one-half as much.

OTTO CYCLE

This was followed by a number of engines by Brayton, Gilles, Halliwell, Bisschop, Andrew, Clerk and others, but in 1876 **Otto** brought out the **Otto Silent Engine**. This engine operated on the Beau de Rochas cycle although independently invented by Otto. This engine was a great success and the form of cycle for many years was known as the **Otto cycle**. It is one of the commonest forms of cycles. It consists, as shown in Fig. 171,

of four strokes: First, a **suction stroke** ab , at a pressure slightly below the atmosphere due to suction of the air from the outside; second, a **compression stroke** bc with **explosion** at the end of the stroke, bringing the pressure from c to d ; third, an **expansion stroke** de followed by **free expansion** ef to a point just above the atmosphere; and fourth, a **discharge stroke** fa at a pressure above the atmosphere due to the discharge being driven out against atmospheric pressure.

In the Beau de Rochas or Otto cycle, the lines of compression and expansion are practically **adiabatics** because the **action is rapid** and also because **gas is a poor conductor**. The gas near the cylinder walls is cooled by the water jacket used but this transfer of heat probably extends only to this film of gas. The cycle requires four strokes for its completion and engines using this form are spoken of as **four cycle engines**. The cycle is practically used on **two cycle engines** in which compressed air is admitted near e driving out the burned gases and this is followed by compressed gas so that when the point f has been passed by a small distance, the burned gases have been driven out and the air and its fuel gas have been introduced. In this way there is an explosion for each revolution.

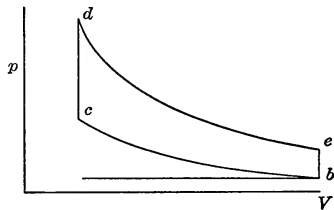

FIG. 172.—Otto cycle.

To study the cycle the lines fa and ab are assumed to coincide and eliminate each other giving Fig. 172 as the **theoretical cycle**. This cycle is made up of two adiabatics and two constant volume lines.

The mixture of unburned gases on bc and the mixture of burned gases on de are different in character and contain different amounts of water vapor and carbon dioxide. For this reason, the lines are different as carbon dioxide and steam are not perfect gases and the variation from the adiabatic of a perfect gas is different for the two lines. Moreover the variations of the specific heat as the temperature rises also causes changes in these lines.

For simplifying computations so as to study the effects of changes on the cycle, a preliminary discussion is often made considering the gases present on all four lines to be air and

considering the specific heats as constant quantities. Such discussions and results are known as results of the **air standard**.

AIR STANDARD EFFICIENCY

Under these conditions and assuming 1 lb. of substance present on the cycle, the heats on the various lines are as follows:

$$\text{Heat on } bc = 0$$

$$\text{Heat on } cd = c_v(T_d - T_c).$$

$$\text{Heat on } de = 0$$

$$\text{Heat on } eb = -c_v(T_e - T_b)$$

$$\text{Work} = c_v(T_d - T_c) - c_v(T_e - T_b)$$

$$\text{Thermal eff.} = \eta_3 = \frac{c_v(T_d - T_c) - c_v(T_e - T_b)}{c_v(T_d - T_c)} \quad (1)$$

$$= 1 - \frac{T_e - T_b}{T_d - T_c} = 1 - \frac{T_b}{T_c} = 1 - \frac{T_e}{T_d} \quad (2)$$

$$= \frac{T_c - T_b}{T_c} = \frac{T_d - T_e}{T_d} \quad (3)$$

Since

$$\frac{T_e - T_b}{T_d - T_c} = \frac{T_b}{T_c} = \frac{T_e}{T_d}$$

This is reduced from the cross products of temperature.

$$T_e T_c = T_b T_d$$

This states that the theoretical efficiency of the Otto cycle, air standard, is equal to the range of temperature on either adiabatic divided by the higher temperature on the adiabatic.

$$\text{Now} \quad \frac{T_b}{T_c} = \left(\frac{V_c}{V_b}\right)^{k-1} \quad (4)$$

But V_c is the clearance volume and V_b is equal to the clearance volume plus the displacement, hence

$$\frac{V_c}{V_b} = \frac{lD}{(l+1)D} = \frac{l}{l+1} \quad (5)$$

$$\text{Hence} \quad \eta_3 = 1 - \left(\frac{l}{l+1}\right)^{k-1} = 1 - \left(\frac{1}{1+\frac{1}{l}}\right)^{k-1} \quad (6)$$

As l decreases the last term becomes smaller and the efficiency increases. That is, the decrease of clearance increases the

efficiency. Of course this increases the pressure at c , hence increasing the compression increases the efficiency. The amount of compression is fixed by the allowable temperature at the end of compression and by the pressure at the end of the explosion. If the pressure of compression is excessive the temperature may be high enough to cause premature explosion while if high with a rich gas the explosion pressure is too high. In practice the pressure at the end of compression is 80 to 160 lbs. per square inch depending on the kind of gas.

As before:

$$\eta_1 = \frac{T_d - T_b}{T_d}$$

$$\eta_2 = \frac{\eta_3}{\eta_1}$$

$$\eta_5 = \frac{AW}{Q_1}$$

$$\eta_4 = \frac{\eta_5}{\eta_3}$$

ATKINSON CYCLE AND DIESEL CYCLE

Certain other cycles have been proposed for gas engines and one will be examined for the purpose of application of theory.

In Fig. 173 the cycle proposed by **Atkinson** is shown. In this engine pistons were so connected by linkage to the shaft that they made strokes of varying length. The suction stroke ab is a short stroke followed by a compression stroke bc . The explosion cd is followed by a long stroke so that the expansion reduces the pressure to the initial value. The discharge stroke ea , which is long, brings the pistons to their original points.

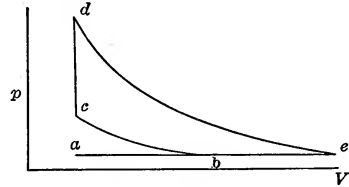

FIG. 173.—Atkinson cycle.

In this case the heat added is

$$Q_1 = c_v(T_d - T_c)$$

The heat removed is

$$Q_2 = c_p(T_e - T_b)$$

$$\text{Work} = Q_1 - Q_2 = c_v[(T_d - T_c) - k(T_e - T_b)]$$

$$\eta_3 = 1 - k \frac{T_e - T_b}{T_d - T_c} \quad (7)$$

Here there is no simple relation between the temperatures at the corners as this is not a **simple cycle** of polytropics.

Rudolph Diesel in the last decade of the 19th century proposed a new cycle of higher efficiency. He recognized the fact that to obtain high efficiencies, the cycle of the gas engine must approximate the Carnot cycle; that the range of temperature on this cycle must be as large as possible and, on account of the loss of availability in conduction, the engine must have internal combustion. He proposed a cycle of isothermal compression from a to b , Fig. 174, followed by adiabatic compression bc to such a high temperature that fuel would ignite on being introduced into the cylinder. The fuel was to be introduced at such a rate that its burning would produce just enough heat to make the expansion from c to d isothermal. After the fuel was cut off the expansion da became adiabatic. His original paper in the *Zeit-*

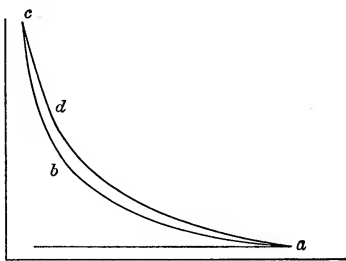

FIG. 174.—Original Diesel cycle.

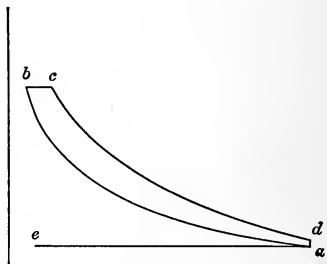

FIG. 175.—Final Diesel cycle.

schrift des Vereins Deutscher Ingenieure was translated in the *Progressive Age* in Dec., 1897 and Jan., 1898. This paper gave the results of his work for a number of years. The great pressure developed by the final compression and the slight gain of area by the isothermal ignition led him to abandon the upper part of the figure, while the desire to reduce the volume led to cutting out the lower end of the figure. Thus modified the **Diesel Cycle** took the form shown in Fig. 175, in which adiabatic compression in a cylinder of small clearance brings the air from a to b at which the temperature is high enough to ignite oil which is injected into the cylinder. If the burning progresses at the proper rate the pressure will be kept constant until cut off at c . From c to d adiabatic expansion takes place followed by exhaust from d to a and finally to e . The suction stroke from e to a

charges the cylinder with air. This is a four-stroke cycle. The efficiency is given by

$$\begin{aligned}\eta_3 &= \frac{c_p(T_c - T_b) - c_v(T_d - T_a)}{c_p(T_c - T_b)} \\ &= 1 - \frac{T_d - T_a}{k(T_c - T_b)}\end{aligned}\quad (8)$$

The high theoretical efficiency is due to the high compression.

ACTUAL ENGINES

The form taken by an actual engine is shown in Fig. 176. This represents an engine of the Otto form. In this air is drawn into the cylinder by the outward motion of the **piston A** through the **valve B**. Gas is admitted by **C** which is so arranged as to

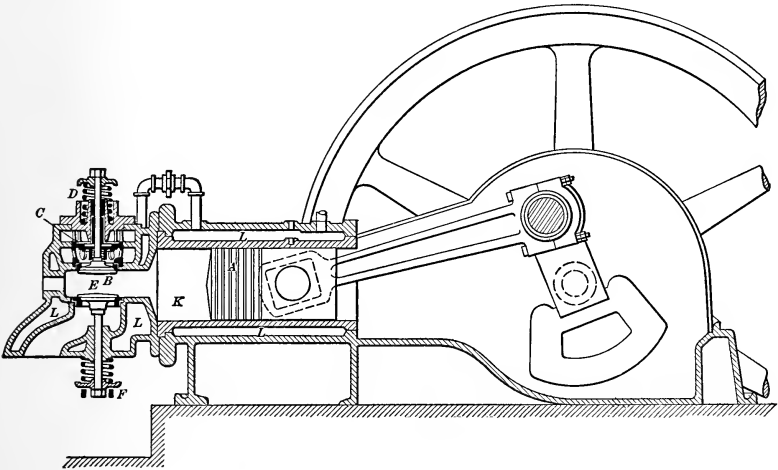

FIG. 176.—Ordinary gas engine. 4-cycle.

open after **B** by means of a shoulder formed by a sleeve attached to the valve stem. These **admission valves** are opened by the suction of the piston or they may be opened **positively** by the valve gearing. They are closed by the **spring D** when the piston reaches the end of its stroke or when the valve mechanism releases them. At the end of the expansion stroke the **exhaust valve E** is opened by the **lever F** operated by a **cam**. The cam is on a **cam shaft**, operated by a bevel or spiral **gear** from the **crank shaft**. The speed of this cam shaft for a four-cycle engine is one-half the speed of the engine shaft. The **governor**

operates to throttle the mixture or to prevent gas from entering as will be explained later. The **cylinder K** contains a **water jacket L** for the purpose of keeping the temperature of the cylinder wall low enough for lubrication and also to prevent seizing.

The two-cycle, **Mietz and Weiss oil** engine, Fig. 177, is similar in action to the four-cycle engine. In this the **explosion and expansion** of the charge compresses air in the **crank case K** and when the **piston A** overrides the **port B** the burned gases escape to the **exhaust pipe M**, while at the next moment the

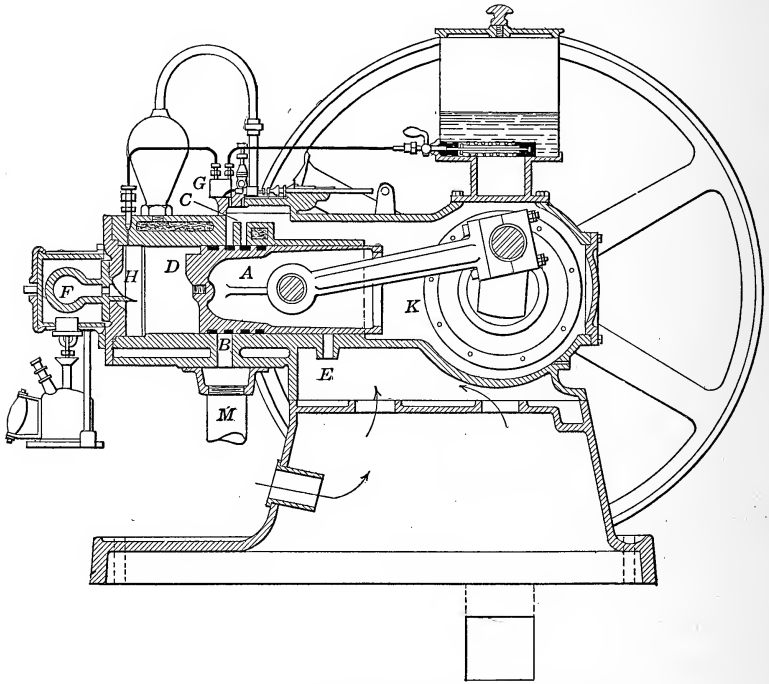

FIG. 177.—Two-cycle Mietz and Weiss oil engine.

ports C are uncovered, admitting the air compressed in the **crank case**. This compressed air rushes in and is deflected to the head by the projecting **finn D** so that the burned gases are blown out or **scavenged**. This reduces the air in the crank case to atmospheric pressure. After the piston passes **C**, the air in the crank case is rarified, as no air can enter, and after passing **B** the air in the cylinder is compressed. When the piston travels back far enough to uncover **port E** air is drawn into

the crank case from the base of the engine by the partial vacuum existing there. In the Mietz and Weiss engine kerosene is sprayed into the cylinder near the end of the stroke by the pump G , and vaporized by the hot cylinder head H and finally ignited by the high temperature from compression in the heated ball F at the end. The mixture then explodes and the action described above is repeated.

In small engines using gasolene, the air entering the crank case is drawn through a **carbureter** in which the air is drawn through gasolene or is mixed with it. This charges the air with fuel and the mixture is ignited at the end of compression by a

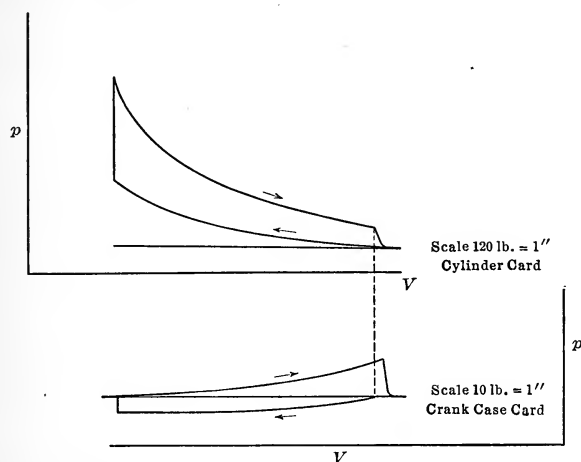

FIG. 178.—Cards from cylinder and crank case of a two-cycle engine.

spark. In large two-cycle engines the fuel gas and air are compressed in piston compressors and admitted to the cylinder at the proper time. Fig. 178 illustrates the form of indicator cards from the cylinder and crank case of the engine above.

GOVERNING

Internal combustion engines are **governed** in two principal ways: (a) by the **hit and miss system** and (b) by the **throttled charge system**. In the hit and miss method of governing the governor acts on the gas or fuel valve so that no gas is admitted when the speed exceeds a given limit, but as long as the limit is not exceeded the engine receives its full charge. In **throttle governing** the charge of fuel and air may be throttled or the

fuel may be throttled alone. In the first of these less fuel mixture is introduced into the cylinder although it is of the proper mixture, while in the second case the mixture is changed. In each of these the explosion pressure will be reduced and the work will be made less. Of course the efficiency in throttle governing is reduced. The disadvantage of the hit and miss system is the fact that the speed may fluctuate, due to this method. In the Diesel engine the governor fixes the point at which the oil supply is cut off.

IGNITION

The charge in most modern gas engines is **ignited by an electric spark** made by breaking a circuit between two platinum points or else causing a high-tension spark to jump a gap between two points of platinum or tungsten. The method of compressing the charge into hot tube until the mixture comes in contact with red hot iron is rarely used at present and compression to a high temperature for ignition is used in some small engines. This latter method is used exclusively on the Diesel engine.

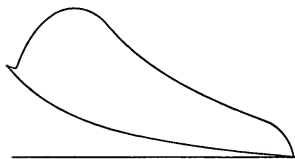

FIG. 179.—After burning or late explosion.

The **rapidity of ignition** depends on the pressure and the quality of the mixture. Thus with higher pressures the ignition is more rapid. In many cases it is found that the explosion is not instantaneous but is continued after the end line as shown in Fig. 179. Such action is called

after burning. This after burning is found to take place in weak mixtures and in throttled supply. The efficiency of the engine is found to increase as more air is added with the gas than that required theoretically. There are several theories given for this, a satisfactory one being that as the heat per cubic foot is decreased by the addition of air, the temperature increase is not so great and the loss from the cylinder is made less, moreover this might give a different specific heat and thus, a lower temperature. The after burning may be explained by the fact that in many cases the high temperatures present prevent chemical combination or may lead to dissociation.

The **amount of dilution** by excess air to insure the presence of sufficient oxygen is a matter of experiment. The excess air may

be sufficient to make the excess air and inert nitrogen amount to about 5 times the gas and the oxygen required to burn it, although much larger variations have been observed in explosive mixtures. The time of explosion varies with the amount of excess air present being slow with large quantities. A slight excess gives a quick explosion. It has been found at times that the best efficiency was obtained even with 100 per cent. excess air.

HEAT TRANSFER TO WALLS

Experiments have been made to determine the **loss of heat to the cylinder walls** in a similar manner to that used for the steam engine. Coker found that there was a cyclic variation of 7°C . or 12.6°F . at a depth of 0.015 in. in the wall of a cylinder of an engine running at 240 r.p.m. In the Seventh Report of the Committee on Gaseous Explosion of the British Association, the results of Dr. Coker and Mr. Scoble are shown. Fig. 180 is taken from this report.

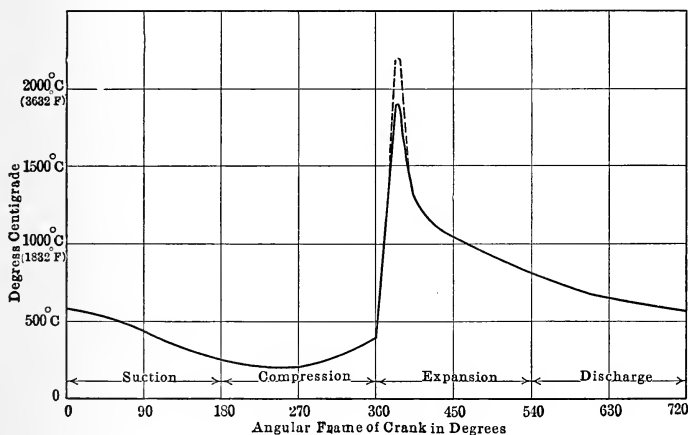

FIG. 180.—Cycle in gas temperature from a gas engine after the Gaseous Explosion Committee Report.

This curve shows the temperature of the working medium as determined by a platinum couple. The couple was placed in a tube which could be cut off from the cylinder by a valve until the desired time. The high temperature of the cycle was not measured but computed because at this temperature the couple would melt if exposed to the gas. These curves show the great variation in temperatures which takes place in the gas engine.

The results of Coker give a variation from 620° F. to 3960° F. for one test, while for another it extended from 390° F. to 3250° F.

The losses from the cylinder walls are due to radiation from the high temperature gas as well as from convection currents. These losses are affected by the density of the gas. An increased density will increase the heat loss. In addition to this fact that the loss is made greater by increasing the density through the increase of compression, the danger of pre-ignition through an increase of the temperature from this cause gives a limit to the possible compression.

FUELS

The fuels used in internal combustions are inflammable gases and oils although Diesel proposed in his patents to use powdered solid fuels. The gases in common use are **natural gas, illuminating gas, producer gas and blast-furnace gas.**

Natural gas is a product of nature found in certain localities in various parts of the world, usually where oils are found. It is rich in methane. Its heating value is high. T. R. Weymouth in the Journal of the A.S.M.E., May, 1912, gives the following average analysis for natural gas of the United States:

Methane, CH ₄	87.00
Ethane, C ₂ H ₆	6.50
Ethylene, C ₂ H ₄	0.20
Carbon monoxide, CO.....	0.20
Hydrogen, H ₂	Trace
Nitrogen, N ₂	5.50
Carbon dioxide, CO ₂	0.50
Helium, He.....	0.10
Oxygen, O ₂	Trace
	<hr/> 100.00

The average heating value of the gas was 887.3 B.t.u. per cubic foot at 29.82 in. and 60° F. The specific gravity compared with air was 0.6135.

Illuminating gas is only used for small installations as the cost is prohibitive. Its heating value is about 700 B.t.u. per cubic foot under standard conditions of 760 mm. and 0° C. This gas may be the product of distilling bituminous coal, the gas amounting to 30 per cent. of the coal. The residue is coke and unless it can be sold this method of utilizing coal is not efficient. If, however, the illuminating gas is made by enriching

producer gas by adding hydrocarbons from crude oil and fixing the mixture, this waste of coke would not occur. If the gas were made for power purposes alone this enrichment would not be made as producer gas is satisfactory for use in gas engines.

An analysis of illuminating gas is given below:

Hydrogen, H ₂	34.3
Methane, CH ₄	28.8
Ethylene, C ₂ H ₄	9.5
Heavy hydrocarbons, C ₂ H ₆	1.7
Carbon dioxide, CO ₂	0.2
Carbon monoxide, CO.....	10.4
Oxygen, O ₂	0.4
Nitrogen, N ₂	14.7
	100.0

The common form of gas used in power installations is **producer gas**. This gas is made from any form of coal or lignite in a **producer** as shown in Fig. 181 or Fig. 182. These represent two forms: the **pressure producer** and the **suction producer**. Fig. 181 illustrates one form of pressure producer of R. D. Wood & Co. In this, air is blown into a **bed** of incandescent fuel *A* by means of the **steam jet blower** *B*. The air burns the carbon to CO₂, but on passing through the thick bed of fuel this is reduced to CO and the gas rises to the outlet *C*. The heat of the fire serves to drive off the volatile matter from the coal.

The carbon burning to CO liberates 4450 B.t.u. per pound of carbon and this heat would be lost in the **scrubber** if not absorbed in some manner. Some of this heat is used to make steam in the top of the producer or in a **boiler** heated by the exhaust gases on their way to the scrubber. If this steam is passed into the ingoing air, the **dissociation** of this by the heat of combustion of the fuel will absorb much of this heat.

The steam used in the air blast cools the gas as it is dissociated into hydrogen and oxygen on passing over the hot coals. This dissociation utilizes part of the heat of combustion of carbon to CO and so utilizes some of that which would be lost in the scrubber. The steam also prevents the fire from clinking. The gas now contains CO, H₂, O₂ and N₂ as well as some volatile gases.

Fresh coal is discharged from the **hopper** *D* into the **chamber** *E* and from this it is distributed by a special device *F* which

produces in a uniform bed. The **openings G** in the top are for the introduction of **slice bars** to break up the fuel bed. The openings **H** on the side are for **observation** of the fuel bed and for barring the bed when necessary. The producer is capped by a water-cooled top and the sides are lined with fire brick. The ashes drop into a **water-sealed base**. From the producer the gas passes through the **outlet C** into a **scrubber** which consists

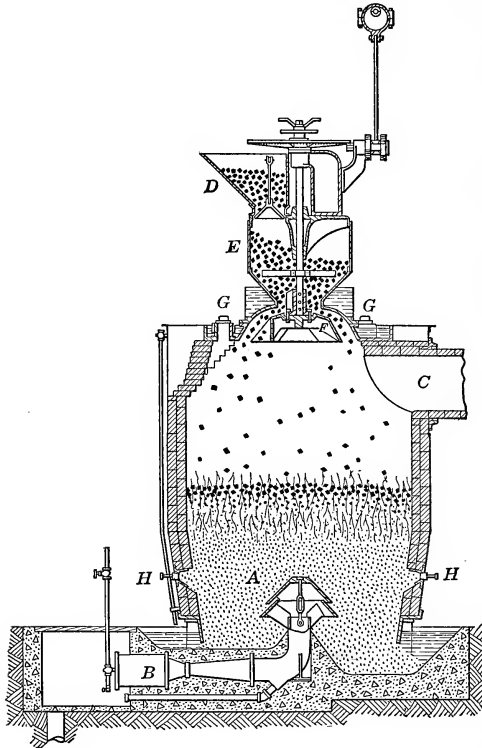

FIG. 181.—Pressure producer of the R. D. Wood Co.

of a metal cylinder filled with coke and cooled by water. The gas enters a water seal at the bottom of the scrubber and leaves at the top. From this point the gas may be taken to a **tar extractor** if the gas contains tar to any extent. This is practically a **centrifugal fan** over which the gas passes, being thrown to the outer edge and thus causing the heavier tar to be caught by the casing. From this point it is taken to the **gas holder**.

In Fig. 182 the **Otto Suction Gas Producer** is shown. In this a suction is produced by the engine drawing in gas. This draws air from the atmosphere at *A* over the hot water in the top of the producer at *B* and thence through the pipe *R* to the bottom of the **fuel bed** *C*. The water is heated by the gas passing from the producer. It then passes through the down pipe *D* to the **seal box**, depositing tar or dirt at the bottom and passing up through the **scrubber** *E*; it finally enters the **receiver** *F* and then passes to the engine.

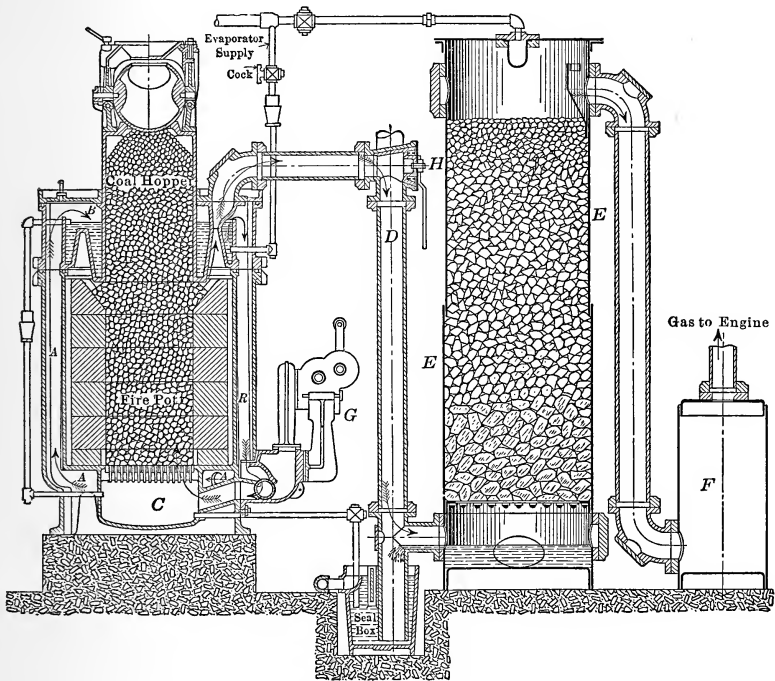

FIG. 182.—Suction producer of the Otto Gas Engine Co.

The blower *G* is used in starting the fire in the producer. The three-way cock *H* is used to direct the gases and smoke to the chimney before burnable gas is produced in starting a fire. The scrubber *E* is filled with coke over which water trickles and through which the gas passes. The spherical charging ball at the hopper mouth prevents gas discharging or air entering.

An analysis of producer gas from soft coal gave the following:

Carbon monoxide, CO.....	20.9
Hydrogen, H ₂	15.6
Carbon dioxide, CO ₂	9.2
Oxygen, O ₂	0.0
Ethylene, C ₂ H ₄	0.4
Methane, CH ₄	1.9
Nitrogen, N ₂	52.0
	<hr/> 100.00

This gas gave 156.1 B.t.u. per cubic foot under standard conditions.

Since 1900 **blast-furnace gas** has been used successfully. Apparently it was first used in England in 1895 on a 12 × 30 – 15-h.p. gas engine and in the same year on an 8-h.p. engine in Belgium; in 1898 a 150-h.p. engine was used; in 1899 a 600-h.p. engine was used in Belgium and exhibited by Cockerill & Co. at the Paris Exposition of 1900. These were followed by larger engines. In 1903 the Lackawanna Steel Company installed a number of 2000-h.p. engines using blast-furnace gas. In most cases the gas is **cleaned by centrifugal washers** before it is applied in the gas engine. This gas was formerly used beneath boilers for steam generation but gas engines utilize the heat more effectively.

An analysis of blast-furnace gas is given herewith:

CO	25.83
CO ₂	9.37
CH ₄	0.54
H ₂	2.96
N ₂	61.30
	<hr/> 100.00

Heat value = 105 B.t.u. per cubic foot.

Crude oil is usually used by the Diesel engine. This oil varies some in composition and heating value. The analysis below is for one form:

C.....	84.9
H.....	13.7
O.....	1.4
	<hr/> 100.0

Its heating value is 19,000 to 20,000 B.t.u. per pound.

Gasolene is the light first distillate from crude petroleum oil. It is easily vaporized and in gas engines it is usually delivered to the air supply by a form of mixer known as a carbureter. Its

heating value is about 20,500 B.t.u. per pound when the steam formed is reduced to water. It contains approximately:

C.....	83.5 per cent.
H.....	15.5 per cent.
N ₂ , S, and O ₂	1.0 per cent.

Kerosene is one of the later distillates of crude mineral oil. It is used on a few engines. It requires a special form of carbureter or vaporizer, requiring a high temperature to properly volatilize the oil. The analysis of this gives:

Carbon.....	84½ per cent.
Hydrogen.....	14 per cent.
Nitrogen and oxygen.....	1½ per cent.

The heating value will be about 19,900 B.t.u. for the higher heating value.

COMBUSTION OF FUELS

The combustion of these various gases is accomplished by the mixing of air with the fuel. To get a mixture which will explode or burn rapidly the quantity of air must be within certain limits, usually the amount necessary for complete combustion plus 15 per cent. will give good results. To find the weight or volume of air to burn any given constituent, reference is made to **chemical formulæ** and **Avogadro's Law**.

Thus to burn 1 volume of CH₄, 2 volumes of oxygen are required—which means 9.54 volumes of air. From this burning 1 volume of CO₂ results and 2 volumes of H₂O. The water may condense. The weights of these per pound of CH₄ are: 4 lbs. oxygen, 17.40 lbs. air, 2¾ lbs. CO₂ and 2¼ lbs. of water. These statements are seen from the following:

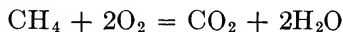

By Avogadro's Law:

1 volume CH₄ + 2 volumes O₂ = 1 volume CO₂ + 2 volumes H₂O.

By chemical equivalents:

[12 + 4.032] lbs. CH₄ + 2[16 × 2] lbs. O₂ = [12 + 32] lbs. CO₂ + 2[2.016 + 16] lbs. H₂O.

or

1 lb. CH₄ + 4 lbs. O₂ = 2¾ lbs. CO₂ + 2¼ lbs. H₂O.

Air contains 77 parts by weight of nitrogen and 23 parts oxygen while by volume the proportion is 79 to 21. Hence 2 volumes of oxygen mean $\frac{2}{0.21}$ or 9.54 volumes of air and 4 lbs. of oxygen mean $\frac{4}{0.23} = 17.40$ lbs. of air.

The **heat of combustion** of CH_4 is 21,566 B.t.u. per pound if the water produced remains as steam or 24,019 B.t.u. per pound if the steam is condensed to water. The former is spoken of as the **lower heating value**, the latter as the **higher**.

In gas-engine work in England, Germany and America, the lower value is taken in determining the efficiencies, while in France the higher value is taken. It is fairer to use the higher heating value and charge the engine with the heat which is present with the steam in the exhaust.

To find the amount of heat per cubic foot of gas the numbers above would be divided by the volume of 1 lb. of the gas under certain definite conditions. The conditions assumed in many cases are 14.7 lbs. per square inch pressure and 32° F. although for natural gas the conditions are often a pressure of 28.7 in. of mercury and 60° F. For the former case the volume of 1 lb. of gas is given by:

$$v = V = \frac{MBT}{p} = \frac{MRT}{p} \times \frac{1}{\text{mol. wt.}} = \frac{1 \times \frac{1544}{\text{mol. wt.}} \times 492}{14.7 \times 144} = \frac{359}{\text{mol. wt.}} \quad (9)$$

The specific weight is given by:

$$m = \frac{1}{v} = \frac{\text{mol. wt.}}{359} \quad (10)$$

For CH_4 : $v = \frac{359}{16.032} = 22.4$ cu. ft.

This gives the values of 1072 B.t.u. per cubic foot for the greater heating value and 963 B.t.u. for the lower value for CH_4 .

Using the methods above for various gases and elements the following table is computed:

GAS COMPOSITION

To study the action of the gas engine theoretically the actual gas supplied and the amount of air or the products of combustion

PROPERTIES OF GASES AND FUELS

	Hydrogen, H ₂	Methane, CH ₄	Ethylene, C ₂ H ₄	Ethane, C ₂ H ₆	Carbon to CO ₂ , C	Carbon to CO, C	Carbon monoxide, CO	Subpur S	Hydrogen sulphide, H ₂ S	Air	Oxygen, O ₂	Nitrogen, N ₂	Water, H ₂ O	Carbon dioxide, CO ₂	Subpur SO ₂	
Molecular wt.....	2.016	16.032	28.032	30.048	12.00	12.00	28.00	32.07	34.086	28.80	32.00	28.02	18.016	44.00	64.07	
Volume per lb.....	178.0	22.40	12.80	11.97	12.80	10.52	12.45	11.21	12.80	19.90	8.17	5.61	
B. t. u.	61,500	24,000	21,400	20,200	14544	4,450	4,325	4,000	3,360
per lb	Low
B. t. u.	345	1,071	1,670	1,835	337	319
per cu. ft. Low.....	291	956	1,565	1,685
Oxygen... required...	8.00	4.00	3.43	3.73	2.67	1.33	0.57	1.00	1.41	-0.23	-1.00	-1.00	-1.00	-1.00	-1.00	-1.00
Cu. ft. per cu. ft.	0.50	2.00	3.00	3.50	0.50	0.50	0.50	0.50	1.50	-0.21	-1.00	-1.00	-1.00	-1.00	-1.00	-1.00
Air	34.70	17.40	14.90	16.20	11.60	5.79	2.49	4.35	6.14	-1.00	-4.35	-4.35	-1.00	-1.00	-1.00	-1.00
Lb. per lb.....	2.38	9.54	14.30	16.65	2.38	7.15	-1.00	-4.76	-4.76	-1.00	-1.00	-1.00	-1.00
Cu. ft. per cu. ft.
CO ₂	2.75	3.14	2.93	3.67	2.33	1.57	1.00
Lb. per lb.....	1.00	2.00	2.00	1.00	1.00
O ₂	-0.23	-1.00	-1.00
Lb. per lb.....	-0.21	-1.00	-1.00
N ₂
Lb. per lb.....
H ₂ O
Lb. per lb.....
Cu. ft. per cu. ft.
SO ₂
Lb. per lb.....
Cu. ft. per cu. ft.
Products of combustion
c _p	Per lb.....	3.424	0.593	0.404	0.243	0.24	0.218	0.244	(0.50)	0.20	0.154
	Per cu. ft.....	0.0192	0.0265	0.0316	0.0190	0.0232	0.0193	0.0194	0.0191	0.0244	0.0275
c _v	Per lb.....	2.446	0.450	0.340	0.173	0.192	0.171	0.155	0.174	0.154	0.122
	Per cu. ft.....	0.0138	0.0201	0.0265	0.0136	0.0182	0.0137	0.0138	0.0136	0.0188	0.0219
α	Per lb.....	3.21	0.402	0.231	0.215	0.231	0.19	0.224	0.202	0.231	0.374	0.101
	Per cu. ft.....	0.018	0.018	0.018	0.018	0.018	0.018	0.018	0.018	0.018	0.0188	0.0202
α'	Per lb.....	2.22	0.279	0.160	0.149	0.160	0.131	0.155	0.14	0.16	0.12	0.07
	Per cu. ft.....	0.0125	0.0125	0.0125	0.0125	0.0125	0.0125	0.0125	0.0125	0.0125	0.0147	0.0125
10 ⁶ b	Per lb.....	33.0	4.16	2.37	2.22	2.38	1.95	2.31	2.08	2.38	6.6	1.04
	Per cu. ft.....	0.185	0.185	0.185	0.185	0.185	0.185	0.185	0.185	0.185	0.807	0.185

must be known. From these the various temperatures and forms of lines may be determined. From the chemical analysis of the fuel gas and the exhaust gas, the amount of air may be found, as will be shown below.

Suppose then that the producer gas given on p. 374 is to be burned in a gas engine with 25 per cent. dilution and it is required to know the amount of air to be admitted, the volume of the mixture, the heat per cubic foot of mixture and the products of combustion.

	Per cent. Vol. gas	Volume air	Heat of combustion	Products of combustion				
				CO ₂	O ₂	N ₂	H ₂ O	SO ₂
CO.....	20.9	49.9	7,060	20.9	39.3
H ₂	15.6	37.2	5,130	29.5	15.6
CO ₂ ...	9.2	9.2
O ₂	0.0	0.0
C ₂ H ₄ ...	0.4	5.7	669	0.8	4.52	0.8
CH ₄	1.9	18.1	2,037	1.9	14.30	3.8
N ₂	52.0	52.00
	100.0	110.9	14,896					
Excess Air....		27.7	5.82	21.30
		138.6	14,896	32.8	5.82	160.92	20.2

This table has been prepared from table on p. 377 for 100 lbs. of gas in the following manner:

$$\text{Air for CO} = 20.9 \times 2.38 = 49.9$$

$$\text{High Heat for CO} = 20.9 \times 337 = 7060$$

$$\text{CO}_2 \text{ from CO} = 20.9 \times 1.0 = 20.9$$

$$\text{N}_2 \text{ from CO} = 20.9 \times 1.88 = 39.3$$

$$\text{B.t.u. per cubic foot mixture} = \frac{14896}{238.6} = 62.5$$

$$\text{Air per cu. ft.} = \frac{138.6}{100} = 1.386$$

$$\text{Vol. of mixture} = 2.38 \text{ cu. ft.}$$

Products of combustion per cubic foot:

$$\text{CO}_2 = 0.328 \text{ cu. ft.}$$

$$\text{O}_2 = 0.058 \text{ cu. ft.}$$

$$\text{N}_2 = 1.609 \text{ cu. ft.}$$

The values of B , c_p and c_v for a mixture are important to con-

sider. Since the molecular weights of the various constituents are different from each other and since the mixture contains CO_2 and water vapor the expressions for specific heat must be computed. The a 's of the expression

$$c_v = a + bt$$

are different for these various substances and the same is true for a 's and b 's. If the values of a , b or a' for 1 lb. of a gas be divided by the volume of 1 lb. under standard conditions the value of these quantities for the heat to be added to 1 cu. ft. of a substance to change its temperature 1 deg. will be found. This might be called the **specific heat of 1 cu. ft.** The reason for using this quantity is the fact that the gas analysis given is usually by volume and the necessity of reducing this to percentage by weight is eliminated. This is done with the heat of combustion to reduce that to the heat per cubic foot.

If v_p is the percentage volume or the relative volume of the various gases in a mixture the following equations hold for the mixture:

v_p = partial volume of any constituent.

$$\text{Mol. wt.}_{mix} = \frac{\Sigma(v_p \times \text{Mol. wt.})}{\Sigma v_p} \quad (11)$$

$$a_{mix} = \frac{\Sigma(v_p \times a)}{\Sigma v_p} \quad (12)$$

$$b_{mix} = \frac{\Sigma(v_p \times b)}{\Sigma v_p} \quad (13)$$

$$a'_{mix} = \frac{\Sigma(v_p \times a')}{\Sigma v_p} \quad (14)$$

$$H_{mix} = \frac{\Sigma(v_p \times H)}{\Sigma v_p} \quad (15)$$

$$C_{pmix} = a_{mix} + b_{mix}T. \quad (16)$$

$$C_{vmix} = a'_{mix} + b_{mix}T. \quad (17)$$

$$B_{mix} = \frac{1544}{\text{Mol. wt.}_{mix}} \quad (18)$$

$$v = \frac{359}{\text{Mol. wt.}} = \frac{B}{4.3} \quad (19)$$

$$k = \frac{C_{pmix}}{C_{vmix}} \quad (20)$$

PROBLEM

Suppose the natural gas given on p. 370 was used in a gas engine and it is required to find the amount of air used per cubic foot of gas and the true products of combustion if the exhaust gas analysis by volume is:

$$\text{CO}_2 = 8.8 \text{ per cent.}$$

$$\text{N}_2 = 85.7 \text{ per cent.}$$

$$\text{O}_2 = 5.5 \text{ per cent.}$$

These analyses show no water vapor from the burning of the gas nor from that taken in with the air and gas. Suppose the gas is at 80° and saturated while the air is taken at 70° and is $\frac{1}{2}$ saturated.

The pressure of the water vapor in the gas is 0.5056 lb. per square inch, while that in the air is 0.1814 lb. per square inch. The barometer is 14.7 lbs. per square inch. Now from Dalton's Law the moisture percentage by volume is equal to the percentage of the dry air pressure which gives the partial pressure. Hence

$$\begin{aligned} \text{Per cent. volume of gas entering equal to moisture} &= \\ &= \frac{0.5056}{14.7 - 0.5056} = 3.56 \text{ per cent.} \end{aligned}$$

$$\begin{aligned} \text{Per cent. volume of air entering equal to moisture} &= \\ &= \frac{0.1814}{14.7 - 0.1814} = 1.25 \text{ per cent.} \end{aligned}$$

On account of pressure and temperature differences of gas and air the theoretic amount of air per cubic foot must be multiplied by

$$\frac{14.7 - 0.5056}{14.7 - 0.1814} \times \frac{460 + 70}{460 + 80} = 0.964$$

to give the actual cubic feet of air per cubic foot of gas.

The true constituents of the gas are those given on p. 370 multiplied by 0.964 to which 3.56 per cent. moisture is added. These quantities are then multiplied by the quantities of the table on p. 377 to give the various volumes of the products of combustion and the volumes of the air required. The results are expressed as a percentage. If the total air required is multiplied by 1.25 per cent. the moisture from the air is found.

The computation is now made.

	Per cent. volume	CO ₂	N ₂	H ₂ O	Air	Heat
CH ₄ 87.00 × 0.964	83.90	83.90	632.0	167.80	800.00	90,100
C ₂ H ₄	0.19	0.38	2.15	0.38	2.72	318
C ₂ H ₆	6.23	12.46	82.50	18.69	104.25	11,420
CO.....	0.19	0.19	0.35	0.45	64
N ₂ + He.....	5.41	5.41
CO ₂	0.48	0.48
H ₂ O.....	3.60	3.60
	100.00	97.41	722.41	190.47	907.42	101,902

$$\begin{aligned} \text{Moisture from air} &= 907.42 \times 0.012 = 10.90 \\ \text{Total moisture} &= 201.37 \end{aligned}$$

The volume of the mixture before burning is

$$100 + 907.42 + 10.9 = 1018.32$$

while after burning the volume is

$$97.41 + 722.41 + 201.37 = 1021.19$$

There is a slight increase in volume.

Products of combustion in the original analysis show that there is some air present. The amount of oxygen is 5.5 per cent. This is associated with

$$\frac{5.5}{0.21} \times 0.79 = 20.6 \text{ per cent. of nitrogen.}$$

The nitrogen in the analysis from combustion must be the difference between 85.7 per cent. and 20.6 per cent.

Nitrogen from combustion = $85.7 - 20.6 = 65.1$ per cent. The nitrogen in the products of combustion give a total of 722.14 parts of which 5.41 have been brought in by the fuel gas, or

$$\frac{5.41}{722.14} \times 65.1 = 0.49$$

is the amount of nitrogen chargeable to gas. The nitrogen from the air required to burn the gas is given by:

$$65.1 - 0.49 = 64.61 \text{ per cent.} = \text{volume of nitrogen}$$

from air to burn gases.

The total nitrogen is $\frac{85.7}{65.1}$ times the nitrogen from combustion, or.

$$\frac{85.7}{65.1} \times 722.41 = 952$$

The free air is $\frac{20.6}{64.61} \times 907.4 = 289.6$.

Total air is $907.4 + 289.6 = 1197$.

Moisture with free air = $0.012 \times 289.6 = 3.48$.

The products of combustion are:

CO ₂	97.41	7.42
N ₂	952.00	72.40
O ₂ $\frac{5.5}{8.8} \times 97.41$	61.10	4.62
H ₂ O $\left\{ \begin{array}{l} 201.37 \\ 3.48 \end{array} \right\}$	204.85	15.56
	<hr/>	<hr/>
	1315.36	100.00

As a check, the total volume of the mixture before burning is:

Volume gas.....	100.0
Volume air.....	1197.0
Volume moisture.....	14.4
Total.....	<hr/> 1311.4

The theoretical air per cubic foot is

$$\frac{907.4}{100} = 9.07 \text{ cu. ft.}$$

The theoretical air at atmospheric conditions

$$9.07 \times 0.96 = 8.71 \text{ cu. ft.}$$

The actual amount is

$$\frac{1197 \times 0.96}{100} = 11.49 \text{ cu. ft.}$$

The heat per cubic foot of mixture entering is

$$\frac{101902}{1311.4} = 77.6 \text{ B.t.u.}$$

The specific heat of the gas mixture entering is given by the following:

	Volumes	
Air.....	1197.00	
CH ₄	83.90	
C ₂ H ₄	0.19	
C ₂ H ₆	6.23	
CO.....	0.19	
N ₂ + He.....	5.41	1292.92
CO ₂	0.48	0.48
H ₂ O.....	3.60	
	14.40	18.00
		1311.40

For the total volume of 1311.20 units the following is true:

V_a	V_b
$1292.92 \times 0.018 = 23.3$	$1292.92 \times 0.185 = 239.0$
$0.48 \times 0.0202 = 0.0098$	$0.48 \times 0.807 = 0.3875$
$18.00 \times 0.0188 = 0.339$	$18.00 \times 0.668 = 12.0$
23.6488	251.3875
$V_{a'}$	
$1292.92 \times 0.0125 = 16.2$	
$0.48 \times 0.0147 = 0.007$	
$18.00 \times 0.0132 = 0.238$	
16.445	

$$VC_p = 23.6488 + 251.39 \times 10^{-5} T$$

For one unit volume

$$C_p = 0.0180 + 0.191 \times 10^{-5} T$$

$$VC_v = 16.445 + 251.29 \times 10^{-5} T$$

$$C_v = 0.0125 + 0.191 \times 10^{-5} T$$

For $T = 1000^\circ \text{ F.}$ these become

$$VC_p = 26.1588$$

$$VC_v = 18.9554$$

$$k = \frac{C_p}{C_v} = \frac{26.1588}{18.9554} = 1.38$$

The B for this mixture of gas and air is found by (18)

	Volume	Molecular weight	Relative weight	Per cent. weight
Air.....	1197.00	× 28.8	= 34,420	94.4
CH ₄	83.90	× 16.032	= 1,344	3.7
C ₂ H ₄	0.19	× 28.032	= 5
C ₂ H ₆	6.23	× 30.048	= 189	0.5
CO.....	0.19	× 28.0	= 5
N ₂ + He.....	5.41	× 28.02	= 151	0.4
CO ₂	0.48	× 44.0	= 21	0.1
H ₂ O.....	18.00	× 18.016	= 324	0.9
			<u>36,464</u>	<u>100.00</u>

$$\text{Mol. wt.}_m = \frac{36464}{1311.40} = 27.78$$

$$B_m = \frac{1544}{27.78} = 55.7$$

For the exhaust gases:

N ₂	72.40		V_a
O ₂	4.62	77.02	$77.02 \times 0.018 = 1.387$
CO ₂	7.42	7.42	$7.42 \times 0.0202 = 0.1496$
H ₂ O.....	15.56	15.56	$15.56 \times 0.0188 = 0.2925$
		<u>100.00</u>	<u>1.8291</u>

	V_b		V_a'
	$77.02 \times 0.185 = 14.25$		$77.02 \times 0.0125 = 0.965$
	$7.42 \times 0.807 = 5.99$		$7.42 \times 0.0147 = 0.109$
	$15.56 \times 0.668 = 10.35$		$15.56 \times 0.0132 = 0.205$
	<u>30.59</u>		<u>1.279</u>

$$VC_p = 1.829 + 30.59 \times 10^{-5} T \quad VC_v = 1.279 + 30.59 \times 10^{-5} T$$

$$C_p = 0.0182 + 0.306 \times 10^{-5} T \quad C_v = 0.0128 + 0.306 \times 10^{-5} T$$

$$\text{For } T = 2000^\circ \text{ F.}; VC_p = 2.441; VC_v = 1.891; k = \frac{2.441}{1.891} = 1.29$$

By the method used for the mixture, the B for the ignited gas is $B = 55.7$. Although this value of B is the same as that for the unburned mixture, the composition is so different that the expressions for specific heats are not the same.

If mixtures on the compression and expansion are those assumed, the values of the various quantities are as follows:

For compression:

$$C_{pm} = 0.0180 + 0.191 \times 10^{-5} T$$

$$C_{vm} = 0.0125 + 0.191 \times 10^{-5} T$$

For 1000° F. , a mean temperature:

$$C_p = 0.0199$$

$$C_v = 0.0144$$

$$k = \frac{0.0199}{0.0144} = 1.38$$

$$B_m = 55.7$$

$$H = 77.6 \text{ B.t.u. per cu. ft.}$$

$$v = 12.95$$

For the exhaust gases:

$$C_{pm} = 0.0181 + 0.295 \times 10^{-5} T$$

$$C_{vm} = 0.0128 + 0.295 \times 10^{-5} T$$

For $T = 2000^\circ \text{ F.}$:

$$C_{pm} = 0.0239$$

$$C_{vm} = 0.0186$$

$$k = \frac{0.0239}{0.0186} = 1.283$$

$$B_m = 55.7$$

$$v = 12.95$$

TEMPERATURES AT CORNERS OF CARD

The various temperatures at the corners of the indicator card of the gas engine cycle are now computed theoretically. In this computation the variation of specific heat will be disregarded at first after which the effect of this variation will be investigated.

In a gas engine the exhaust gas which remains in the cylinder warms the incoming gas and changes its temperature. For

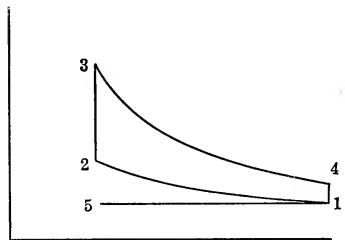

FIG. 183.—Theoretic form of indicator card.

this reason the amount of gas actually used by an engine cannot be told by the change in volume. Moreover the heat removed by the cylinder jacket during the different events affects the results. Consider the card of Fig. 183. On the suction stroke 5-1 a charge of gas and air is drawn in, mixing with the burned gases of volume V_5 in the clearance space. The

temperature of the gases in the clearance space T_5 will be equal to the temperature resulting from the expulsion of the exhaust gases from point 4. The gas which remains in the cylinder at 4 acts on the gas driven out to force it into the atmosphere and hence it may be considered to expand adiabatically in driving out the exhaust. The gas in contact with the piston from 1 to 5 may be considered to be at a constant temperature equal

to that due to adiabatic expansion from 4 to 1 if no loss or gain of heat from the cylinder walls be considered. Thus:

$$T_5 = T_4 \left(\frac{p_1}{p_4} \right)^{\frac{k-1}{k}} \quad (21)$$

$$\text{But} \quad \frac{p_1}{p_4} = \frac{p_2}{p_3} = \frac{T_2}{T_3} \quad (22)$$

$$\text{Hence} \quad T_5 = T_4 \left(\frac{T_2}{T_3} \right)^{\frac{k-1}{k}} \quad (23)$$

The mixture of this burned gas of weight

$$M_o = \frac{p_5 V_5}{B T_5}$$

and the fresh charge will result in a volume of gas V_1 at a pressure p_1 and at a temperature T_1 . The weight of this mixture of fresh air and gas and the burned gas will weigh M_2 pounds.

$$M_2 = \frac{p_1 V_1}{B T_1}$$

Although the values of B are not quite the same in these two formulæ they may be considered the same in this work.

If this gas enters the cylinder from 5 to 1 the work done by the entering gas on the piston, $p_1(V_1 - V_5)$, will just equal the work done by the atmosphere in forcing the air into the cylinder so that this need not be considered in equating the energy at 5 plus the energy in the air entering to the energy at 1.

$$\frac{p_5 V_5}{0.4} + (M_2 - M_o) J c_v T_a = \frac{p_1 V_1}{0.4} \quad (24)$$

$$p_5 = p_1.$$

$$\begin{aligned} \frac{p_1(V_1 - V_5)}{0.4} &= \left(\frac{p_1 V_1}{B T_1} - \frac{p_5 V_5}{B T_5} \right) J c_v T_a \\ \frac{p_1(V_1 - V_5)}{0.4 T_a} &= \frac{p_1}{0.4} \left(\frac{V_1}{T_1} - \frac{V_5}{T_5} \right) \end{aligned} \quad (25)$$

Now the clearance V_2 or V_5 is given as l times the displacement of the piston.

$$V_5 = l [V_1 - V_5] \quad (26)$$

$$V_5 = \frac{l}{1+l} V_1 \quad (27)$$

$$\text{Hence} \quad \frac{1}{1+l} \frac{V_1}{T_a} = \left(\frac{1+l}{T_1} - \frac{l}{T_5} \right) \frac{V_1}{1+l}$$

$$T_1 = \frac{(1+l)(T_a T_5)}{T_5 + lT_a} \quad (28)$$

Substituting for T_5 its value from (23), T_1 reduces to

$$T_1 = \frac{(1+l) \left[T_a T_4 \left(\frac{T_2}{T_3} \right)^{\frac{k-1}{k}} \right]}{T_4 \left(\frac{T_2}{T_3} \right)^{\frac{k-1}{k}} + lT_a} \quad (29)$$

$$\text{Now } T_2 = T_1 \left(\frac{V_1}{V_2} \right)^{k-1} = T_1 \left(\frac{1+l}{l} \right)^{k-1} = \alpha T_1 \quad (30)$$

$$\alpha = \left(\frac{1+l}{l} \right)^{k-1} \quad (31)$$

$$T_4 = \frac{T_3}{\alpha} \quad (32)$$

Now the heat added from 2 to 3 is called VH and is equal to $VC_v(T_3 - T_2)$ hence

$$T_3 = T_2 + \frac{VH}{VC_v} = \alpha T_1 + \frac{H}{C_v} \quad (33)$$

$$\text{Hence } T_4 = T_1 + \frac{H}{C_v \alpha} \quad (34)$$

These equations reduce equation (29) to

$$T_1 = \frac{(1+l)T_a \left[T_1 + \frac{H}{C_v \alpha} \right] \left[\frac{\alpha}{\alpha + \frac{H}{C_v T_1}} \right]^{\frac{k-1}{k}}}{\left[T_1 + \frac{H}{C_v \alpha} \right] \left[\frac{\alpha}{\alpha + \frac{H}{C_v T_1}} \right]^{\frac{k-1}{k}} + lT_a} \quad (35)$$

In this equation the only unknown is T_1 but the equation is implicit so that its solution is best made by trial. After T_1 is found the other temperatures may be found in succession. Thus suppose in an engine with 25 per cent. clearance, the outside gas is at a temperature of 70° F. and the heat per cubic foot is 80 B.t.u. while the value of C_v per cubic foot is 0.013.

$$\alpha = \left(\frac{1.25}{0.25} \right)^{0.4} = 1.9$$

$$T_1 = \frac{1.25 \times 530 \left[T_1 + \frac{80}{0.013 \times 1.9} \right] \left[\frac{1.9}{1.9 + \frac{80}{0.013 \times T_1}} \right]^{\frac{k-1}{k}}}{\left[T_1 + \frac{80}{0.013 \times 1.9} \right] \left[\frac{1.9}{1.9 + \frac{80}{0.013 \times T_1}} \right]^{\frac{k-1}{k}} + (0.25 \times 530)}$$

Since the last term in the denominator is small the value of T_1 is practically equal to $(1 + l)T_a$ although on account of another term being additive, the value will be slightly smaller. $(1 + l)T_a = 1.25 \times 530 = 662$. Hence try $T_1 = 625$.

$$T_1 = \frac{1.25 \times 530 \times 3855 \times 0.593}{3855 \times 0.593 + 132} = 628$$

If 627 is tried

$$T_1 = \frac{1.25 \times 530 \times 3857 \times 0.618}{3857 \times 0.618 + 132} = 626$$

Use 626. $T_2 = 626 \times 1.9 = 1190$

$$T_3 = 1190 + \frac{80}{0.013} = 7340$$

$$T_4 = \frac{7340}{1.9} = 3860$$

These are all higher than the values found in practice due to the fact that the combustion on the line 2-3 is not always complete at the point 3, that the jacket removes heat from the cylinder and also because the specific heat varies with the temperature increasing perceptibly at the higher temperatures. If the heat of combustion from 2-3 be reduced to 75 per cent. of its value the temperature T_3 will be materially decreased.

ADIABATICS

The compression and expansion lines of the card have been assumed to be adiabatics of the form

$$pv^{1.4} = \text{const.} \quad (26)$$

This assumes that the gases are perfect gases and that c_p and c_v are constant. Now the true forms for the specific heat are

$$c_p = a + bT \quad (16)$$

and

$$c_v = a' + bT \quad (17)$$

and the equation of the adiabatic is

$$0 = c_v dt + A p dv = (a + bT) dt + A p dv$$

$$\frac{a dt}{T} + b dt = - AB \frac{dv}{v} \quad (36)$$

In the above expressions the quantities refer to 1 lb. although as will be seen later it might be simpler to have them refer to 1 cu. ft.

The integration of this between limits finally gives

$$a' \log_e \frac{T_2}{T_1} + b(T_2 - T_1) = - AB \log_e \frac{V_2}{V_1} \quad (37)$$

From this T_2 may be found if T_1 and $\frac{V_2}{V_1}$ are known.

Now

$$n = \frac{\log \frac{p_2}{p_1}}{\log \frac{V_1}{V_2}} = \frac{\log \frac{T_2}{T_1} - \log \frac{V_2}{V_1}}{\log \frac{V_1}{V_2}} \quad (38)$$

Since

$$\frac{p_2}{p_1} = \frac{T_2}{T_1} \frac{V_1}{V_2}$$

In a form involving T_2 and T_1 only, this may be written

$$n = \frac{AB \log_e \frac{T_2}{T_1} + a' \log_e \frac{T_2}{T_1} + b(T_2 - T_1)}{a' \log_e \frac{T_2}{T_1} + b(T_2 - T_1)} \quad (39)$$

Of course since $\frac{v_2}{v_1}$ must be known to find T_2 and T_1 this form is not necessary, except in cases in which it is desired to know the value of n over a given range of temperatures. This is a closer value of n for the range from T_2 to T_1 than the value $\frac{c_p}{c_v}$.

Equation (37) may be written

$$a' \log_e T + bT + AB \log_e V = \text{const.} \quad (40)$$

$$a' \log_e p + a' \log_e V + AB \log_e V + bT = \text{const.}$$

$$a' \log_e p + a \log_e V + bT = \text{const.}$$

$$p^{a'} V^a e^{bT} = p^{a'} V^a \epsilon^{\frac{b p v}{B}} = \text{const.} \quad (41)$$

These equations considering the variation of c_v with temperature will cut down the pressure of compression and its temperature and thus affect the expression for efficiency of the air cycle.

EFFICIENCY CHANGE

The change in efficiency due to this change in c_v may be computed as follows:

$$\eta_3 = 1 - \left(\frac{l}{1+l} \right)^{k-1} \quad (6)$$

$$k - 1 = \frac{AB}{c_v}$$

$$\eta_3 = 1 - \left(\frac{l}{1+l} \right)^{\frac{AB}{c_v}} \quad (42)$$

$$\frac{d\eta_3}{dc_v} = \left(\frac{l}{1+l} \right)^{\frac{AB}{c_v}} \log_e \left(\frac{l}{1+l} \right) \frac{AB}{c_v^2} \quad (43)$$

$$= \frac{AB}{c_v^2} (1 - \eta_3) \log_e \left(\frac{l}{1+l} \right)$$

$$\frac{d\eta_3}{\eta_3} = \frac{dc_v}{c_v} \left[\frac{AB}{c_v} \frac{1 - \eta_3}{\eta_3} \log_e \left(\frac{l}{1+l} \right) \right] \quad (44)$$

This expression would give the fractional variation of efficiency $\frac{d\eta_3}{\eta_3}$, due to the fractional change in the value of c_v , $\left(\frac{dc_v}{c_v} \right)$.

TEMPERATURE AFTER EXPLOSION

To find the temperature after burning, on the assumption that no heat is taken away; the intrinsic energy after burning is made equal to the heat per cubic foot plus the intrinsic energy before burning. If there is an assumed loss of heat to the jackets of 20 per cent. of the heat of combustion this same method is used with 80 per cent. of the heating value of the fuel.

$$U_2 = U_1 + H \times (100 - \text{per cent. loss to jackets}) \quad (45)$$

The intrinsic energy at any point is given by

$$U = \int_0^T c_v dt = a'T + \frac{bT^2}{2} \quad (46)$$

Hence

$$a'T_2 + \frac{bT_2^2}{2} + H(1 - \text{loss to jackets}) = a'_1T_3 + \frac{b_1}{2} T_3^2 \quad (41)$$

The values of $a'T_2 + \frac{b}{2}T_2^2$ and of $a'_1T_3 + \frac{b_1}{2}T_3^2$ are sometimes plotted as shown in Fig. 184 so that for a given temperature T_2 the heat contained in the gas is read from the figure. After adding H or a portion of H to this, the curve for the burned mixture

will give T_3 corresponding to the heat contained in each pound, or cubic foot, the intrinsic energy.

To find the temperature at 4 equation (37) is used.

If now the mixture at point 1 is assumed to be at 626° absolute, the temperature at the various points may be found by the methods given above. Assume the gases are those mentioned on p. 380 and that the clearance is 25 per cent. Of course T_1 would be worked out by equation (35) if not known. Using

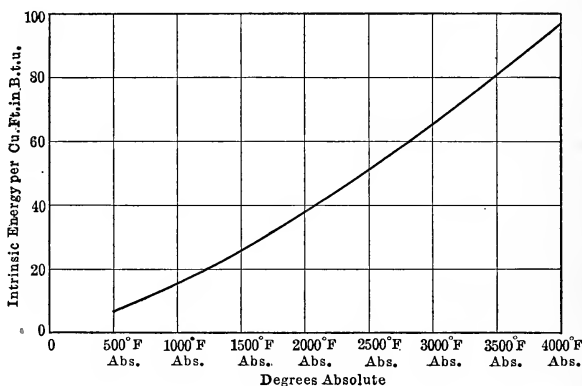

FIG. 184.—Plotting of intrinsic energy for variable specific heat.

data for the mixture on p. 383 in equation (37), the following results:

$$12.95 \times 0.0125 \times 2.3 \log \frac{T_2}{626} + 12.95 \times 0.191 \times 10^{-5} [T_2 - 626]$$

$$= \frac{1}{778} \times 55.7 \times 2.3 \log 5$$

$$\log T_2 + 6.66 \times 10^{-5} T_2 = 2.797 + 0.0417 + 0.309 = 3.148$$

$$\text{Assume } \log T_2 = 3.148$$

$$T_2 = 1400$$

This is of course too large due to the second term.

$$\text{Assume } T_2 = 1200$$

$$3.080 + 0.080 = 3.160$$

slightly too large

$$\text{Try } T_2 = 1150$$

$$3.061 + 0.077 = 3.148$$

This is correct.

The value of n by equation (38) is

$$n = \frac{\log \frac{1150}{626} + \log 5}{\log 5} = \frac{0.265 + 0.699}{0.699} = 1.38$$

This is the same value found for the ratio of $\frac{C_p}{C_v}$ which was given as 1.38. That the value of 1150 may be seen to be correct the following computation is made by equation (4).

$$T_2 = T_1 \left(\frac{v_1}{v_2} \right)^{n-1} = 626 \left(\frac{5}{1} \right)^{0.38} = 1150$$

To find T_3 the correct method is to equate the intrinsic energy at 3 to that at 2 plus the heat of combustion. Since the composition of gas after burning is not the same as that before, the specific heat is not constant during burning nor are a' and b constant during this change. Hence the above method is the only one which may be used to find T_3 .

$$a'_m T_2 + \frac{b}{2} T_2^2 + H = a'_1 T_3 + \frac{b_1}{2} T_3^2$$

$$12.95 \times 0.0125 \times 1150 + \frac{12.95}{2} \times 0.191 \times 10^{-5} (1150)^2 + 12.95 \\ \times 77.6 \times 0.80 = 12.95 \times 0.0128 \times T_3 + \frac{12.95}{2} \times 0.306 \times 10^{-5} T_3^2$$

$$T_3^2 + 8360 T_3 = 50,700,000$$

$$T_3 + 4180 = 8260$$

$$T_3 = 4080^\circ \text{ F.}$$

T_4 is found by equation (37) used for the determination of T_2 .

$$12.95 \times 0.0128 \times 2.3 \times \log \frac{4080}{T_4} + 12.95 \times 0.295 \times 10^{-5}$$

$$\times [4080 - T_4] = \frac{1}{778} \times 55.7 \times 2.3 \log 5$$

$$\log T_4 + 10.04 \times 10^{-5} T_4 = 3.610 + 0.408 - 0.301 = 3.717$$

$$\text{For } \log T_4 = 3.71$$

$$T_4 = 5150$$

This, of course, is too large.

$$\text{Try } T_4 = 3000$$

$$3.478 + 0.302 = 3.780$$

Too large. Try $T_4 = 2500$

$$3.399 + 0.252 = 3.651$$

Too small. Try $T_4 = 2750$

$$3.440 + 0.280 = 3.720$$

Too large. Try $T_4 = 2740$

which gives $3.438 + 0.275 = 3.713$

$$n = \frac{\log \frac{4080}{2745} + \log 5}{\log 5} = \frac{0.172 + 0.699}{0.699} = 1.23$$

In the calculation for the value of n on the two lines, it has been found that on the compression line $n = 1.38$ while on the expansion line $n = 1.23$. From actual tests as mentioned on page 214, $n = 1.288$ on compression and 1.352 on expansion. The value of n is found by plotting the logarithms of the volumes and pressures of various points and drawing a straight line the slope of which will give the value of n . These temperatures, 626, 1150, 4080 and 2745, are not much higher than those found in practice.

TEMPERATURE ENTROPY DIAGRAM

The temperature entropy diagram for a gas-engine cycle may be easily constructed from the indicator diagram by the method

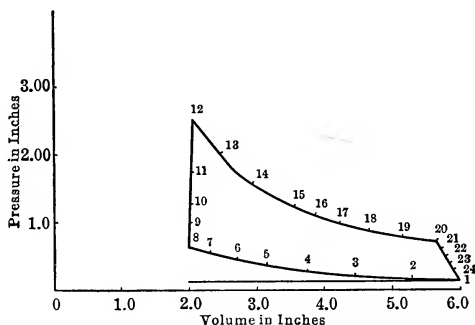

FIG. 185.—Card prepared for T-S analysis.

shown below. The mean indicator card, Fig. 185, is constructed from a number of cards in the same manner as that used in the Hirn's or Temperature Entropy Analysis, and then the lines of absolute zero of volume and of pressure are laid off after meas-

uring the clearance and calibrating the indicator spring. A series of points is then marked and the distances from the axes are measured in inches. These are tabulated as shown:

Points	Pressure in inches	Volume in inches	$\frac{P_x}{P_1}$	$\frac{V_x}{V_1}$	$\log \frac{p_x}{p_1}$	$\log \frac{V_x}{V_1}$	$k \log \frac{V_x}{V_1}$	$S_x - S_1$	$\frac{T_x}{T_1}$
1	0.15	6.00	1.00	1.000	0.000	-0.000	-0.000	0.000	1.000
2	0.178	5.25	1.18	0.873	0.072	-0.060	-0.084	-0.012	1.030
3	0.224	4.43	1.49	0.737	0.173	-0.132	-0.185	-0.012	1.098
4	0.282	3.75	1.88	0.625	0.274	-0.204	-0.286	-0.012	1.175
5	0.350	3.18	2.33	0.530	0.367	-0.276	-0.385	-0.018	1.235
6	0.447	2.68	2.98	0.447	0.474	-0.350	-0.490	-0.016	1.335
7	0.563	2.27	3.76	0.378	0.575	-0.423	-0.592	-0.017	1.422
8	0.669	2.00	4.45	0.332	0.648	-0.479	-0.671	-0.023	1.478
9	1.000	2.01	6.48	0.333	0.825	-0.478	-0.670	0.155	2.260
10	1.260	2.015	8.60	0.335	0.924	-0.476	-0.668	0.256	2.810
11	1.78	2.025	11.86	0.337	1.074	-0.472	-0.660	0.414	4.000
12	2.51	2.040	16.79	0.339	1.224	-0.470	-0.658	0.566	5.680
13	2.00	2.470	13.35	0.412	1.125	-0.385	-0.539	0.586	5.490
14	1.58	2.940	10.50	0.488	1.022	-0.312	-0.437	0.585	5.130
15	1.24	3.55	8.25	0.590	0.916	-0.229	-0.320	0.596	4.860
16	1.13	3.87	7.52	0.643	0.876	-0.192	-0.268	0.608	4.840
17	1.00	4.23	6.67	0.705	0.824	-0.152	-0.213	0.611	4.770
18	0.89	4.65	5.93	0.775	0.773	-0.111	-0.155	0.618	4.590
19	0.795	5.13	5.30	0.855	0.724	-0.068	-0.095	0.629	4.480
20	0.710	5.64	4.73	0.940	0.674	-0.027	-0.038	0.636	4.450
21	0.60	5.70	4.00	0.950	0.602	-0.022	-0.031	0.571	3.800
22	0.50	5.77	3.33	0.960	0.523	-0.018	-0.025	0.498	3.190
23	0.40	5.83	2.67	0.971	0.426	-0.012	-0.017	0.409	2.590
24	0.30	5.89	2.00	0.980	0.301	-0.009	-0.013	0.288	1.960

Now if one of the points, say 1, be taken as the datum point, the ratios of the temperature at various points to the temperature of this datum point and the change of entropy from this datum may be figured. Thus considering the point 2:

$$\frac{T_2}{T_1} = \frac{p_2 V_2}{p_1 V_1}$$

$$\frac{T_2}{T_1} = \left(\frac{p_2}{p_1}\right) \left(\frac{V_2}{V_1}\right). \quad (48)$$

This ratio holds to the point of explosion since the unburned mixture after burning is different in volume, due to the change on burning, and it is necessary to change the temperature found by the above formula in the following proportion:

$$T' = T \frac{\text{vol. of mixture}}{\text{vol. of burned gases}} \quad (49)$$

In practical application the change in volume due to chemical action is so slight that the volume ratio is assumed unity.

If the temperature of the point 1 be assumed on the T - S diagram, the height to other points may be found by multiplying by the ratio $\frac{T_2}{T_1}$. If the height to 1 be made 1 in. the ratio $\frac{T_2}{T_1}$ will give the heights to the various points. Of course the scale of temperature is not known until one temperature is known. As will be shown, much data can be determined even if this scale is not known.

$$\text{Now} \quad ds = c_p \frac{dv}{v} + c_v \frac{dp}{p}$$

$$s_2 - s_1 = c_p \log_e \frac{v_2}{v_1} + c_v \log_e \frac{p_2}{p_1} \quad (50)$$

$$\frac{s_2 - s_1}{2.3 c_v} = \frac{c_p}{c_v} \log_{10} \frac{v_2}{v_1} + \log_{10} \frac{p_2}{p_1} \quad (51)$$

$$\text{Now} \quad \frac{s_2 - s_1}{2.3 c_v} = \frac{s_2 - s_1}{\text{const.}}$$

The constant of this expression only changes the scale of entropy if the expression

$$k \log_{10} \frac{V_2}{V_1} + \log_{10} \frac{p_2}{p_1} \quad (52)$$

is plotted as the entropy. Fig. 186 is obtained by this method and the area of the figure which represents the difference between the heat added and that taken away is equal to the work done or the work shown by the indicator card. If the area scale of the indicator card is known in B.t.u. per square inch the area scale of the T - S diagram will be inversely proportional to the areas of the two figures.

$$\text{Scale}_{ts} = \frac{F_{pv}}{F_{ts}} \times \text{Scale}_{pv} \quad (53)$$

$$\text{Scale}_{p.v.} = \frac{\text{cu. ft. per in.} \times \text{lbs. persq. ft. per in.}}{778}$$

$$F_{pv} = \text{area of } p\text{-}v \text{ diagram}$$

$$F_{ts} = \text{area of } T\text{-}S \text{ diagram} \quad (54)$$

The scale fixes the heat and efficiency of the cycle, although the component scales of temperature and entropy are not known. As soon, however, as one temperature is determined the scale

LOGARITHMIC DIAGRAM

In Fig. 187 the logarithmic diagram for the indicator card is drawn and from it the values of the exponents n are found.

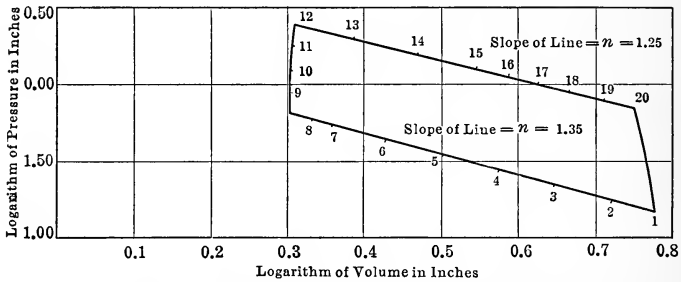

FIG. 187.—Logarithmic diagram of gas engine card.

TEST OF GAS ENGINE

As a closing problem on gas engines the following data is taken from a report on a test of a producer and two-cylinder gas engine reported by Prof. H. W. Spangler in the Journal of the Franklin Institute, May, 1893. The data is as follows:

2 cylinders each.....	14 5/8 in. × 25 in.
Coal—by weight—	
Moisture.....	4.20 per cent.
Volatile matter (5.80 per cent. CH ₄ , 0.73 per cent. H ₂).....	6.88 per cent.
Fixed carbon	80.41 per cent.
Ash.....	8.51 per cent.
	<hr/> 100.00
Sulphur.....	0.74 per cent.
Time of test.....	525 min.
Revolutions.....	84,425 160.76 r.p.m.
Explosions.....	81,673 155.44 ex.p.m.
Mean gas pressure.....	11 1/16 in. = 0.062 lbs. per sq. in.
Barometer.....	14.686 lbs. per sq. in.
Gas temperature	75.5° F.
Room temperature	81.3° F.
Jacket temperature outlet	99.23° F.
Jacket temperature inlet	62.42° F.
Exhaust pyrometer.....	752.6° F.
Brake load.....	1148.5 lbs.
Zero brake load.....	160.0
Brake arm.....	3.073 ft.
B.h.p.....	92.73
I.h.p.....	
Top cylinder.....	64.36
Bot. cylinder	66.80 131.16
Coal.....	<hr/> 1069.6 lbs.

Fuel gas by volume	CO ₂	4.02	per cent.
	O ₂	0.26	
	CO.....	25.38	
	H ₂	4.51	
	CH ₄	1.79	
	N ₂	64.04	100.00

Exhaust gas by volume	CO ₂ ...	15.60	per cent.
	O ₂	2.24	
	CO....	0.28	
	N ₂	81.93	100.00

Cooling water..... 664 lb. in 4 min.
 Gas for ignition tube..... 840 cu. ft.
 Relative humidity of air..... 80 per cent.

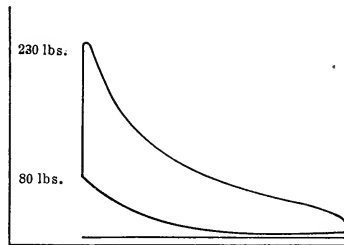

FIG. 188.—Average card from test of Otto engine.

The following data will be computed:

Heat of coal	C = 80.41 × 14,544 =	11,690
	H ₂ = 0.73 × 61,500 =	449
	CH ₄ = 5.80 × 24,000 =	1,390
		<u>13,529</u>

Total heat supplied 1069.6 × 13,529 = 14,470,600 B.t.u.

Carbon per pound of gas:

Relative carbon from CO ₂	= 4.02 × 12 =	48.24
Relative carbon from CO	= 25.38 × 12 =	304.56
Relative carbon from CH ₄	= 1.79 × 12 =	<u>21.48</u>
Total relative carbon.....		374.3

Relative weight of gas:

From CO ₂	4.02 × 44 =	176.5
O ₂	0.26 × 32 =	8.3
CO.....	25.38 × 28 =	710.0
H ₂	4.51 × 2 =	9.0
CH ₄	1.79 × 16 =	28.6
N ₂	64.04 × 28 =	1792.0
	<u>100.00</u>	<u>2724.4</u>

$$\text{Hence molecular weight of mixture} = \frac{2724.4}{100} = 27.24$$

$$\text{Carbon in 1 lb. of gas} = \frac{374.3}{2724.4} = 0.1372$$

Carbon per pound coal

$$\text{From C} = 0.8041 \times 1 = 0.8041$$

$$\text{From CH}_4 = 0.0580 \times \frac{12}{16} = \frac{0.0435}{0.8476}$$

$$\text{Pound of gas per pound of coal} = \frac{0.8476}{0.1372} = 6.18 \text{ lbs.}$$

$$\text{Volume of 1 lb. of gas} = \frac{359}{27.24} = 13.1.$$

$$\text{Volume of gas per pound of coal} = 6.18 \times 13.1 = 81.00 \text{ cu. ft.}$$

Heating value of gas per cubic foot:

	High	Low
From CO = 0.2538 × 337 =	85.5	85.5
From H ₂ = 0.0451 × 345 =	15.5	13.1
From CH ₄ = 0.0179 × 1071 =	19.2	17.1

$$\text{Heat per cubic foot, B.t.u.} \dots\dots 120.2 \text{ B.t.u. } 115.7 \text{ B.t.u.}$$

$$\text{Heat in gas per pound coal} = 81 \times 120.2 = 9740 \text{ B.t.u.}$$

$$\begin{aligned} \text{Efficiency of producer} &= \frac{9740}{13529} = 0.72 \\ \text{(neglecting temperature)} & \\ &= 72\%. \end{aligned}$$

$$\text{Indicated work} \dots\dots\dots 131.16 \times 2546 \times \frac{525}{60} = 2,920,000.$$

$$\text{Indicated thermal efficiency of producer and engine} = \frac{2920000}{14470600} = 20.2\%.$$

$$\text{Indicated thermal efficiency of engine} = \frac{20.2}{0.72} = 0.281 = 28.1\%.$$

$$\text{Delivered work} = 92.73 \times 2546 \times \frac{525}{60} = 2,070,000.$$

$$\text{Delivered thermal efficiency of producer and engine} = \frac{2070000}{14470600} = 14.30\%.$$

$$\text{Delivered thermal efficiency of engine} = \frac{14.30}{72.00} = 0.199 = 19.9\%.$$

$$\text{Heat in cooling water} = 664 \times \frac{525}{4} [99.23 - 62.42] = 3,220,000.$$

$$\text{Percentage of heat in coal removed by jacket water} = \frac{3220000}{14470600} = 22.2\%.$$

$$\text{Percentage of heat in gas removed by jacket water} = \frac{22.2}{72.0} = 30.9\%.$$

Air required per cubic foot of gas:

The products of combustion for complete combustion and no dilution are:

	Per cent. vol.	CO ₂	N ₂	H ₂ O	Air
CO ₂	0.0402	0.0402
O ₂	0.0026	0.0098	0.0124
CO.....	0.2538	0.2538	0.4300	0.6080
H ₂	0.0451	0.0451	0.1070
CH ₄	0.0179	0.0179	0.1443	0.0358	0.1710
N ₂	0.6404	0.6404
		0.3119	1.2545	0.0809	0.8736

The analysis of exhaust gases shows 15.60 per cent. by volume of CO₂ and 0.23 per cent. CO. Now 1 volume of CO would produce 1 volume of CO₂. Hence if $\frac{0.23}{15.83} \times 0.3119 = 0.0045$ cu. ft. be left as CO the proportions will be as follows:

CO ₂	0.3074
CO.....	0.0045
N ₂	1.2464
H ₂ O.....	0.0809

Air Required..... 0.8629

The exhaust gases contain 2.24 per cent. of O₂ and 15.60 per cent. CO₂ hence there must be

$$\frac{2.24}{15.60} \times 0.3074 = 0.044 \text{ cu. ft.}$$

of O₂ per cubic foot of gas, or

$$\frac{0.044}{0.21} = 0.21 \text{ cu. ft. of air in excess.}$$

This gives as the total amount of air per cubic foot 0.21 + 0.8629 = 1.0739. The amount of air theoretically required is 0.8629 cu. ft. and hence the per cent. excess is

$$\frac{0.21}{0.8629} = 24.2 \text{ per cent.}$$

The products of combustion without moisture will then be:

CO ₂	0.3074 cu. ft.
CO.....	0.0045 cu. ft.
N ₂	1.2464 cu. ft.
H ₂ O.....	0.0809 cu. ft.
Air.....	0.2100 cu. ft.
Total.....	1.7492 cu. ft.

These came from 1 cu. ft. of gas and 1.0729 cu. ft. of air.

The gas passes from the wet scrubber to the engine and is therefore

saturated. Moisture in gas is sufficient to saturate same at 75.5° F. and will exert a pressure of 0.436 lb. and hence for a barometer of 14.686 lbs. and a pressure of 0.062 lbs. gauge or 14.748 lbs. absolute, the moisture occupying 1 cu. ft. at 0.436 lb. would occupy

$$\frac{0.436}{14.748} = 0.0296 \text{ cu. ft.}$$

at atmospheric pressure plus gas pressure.

The air at 81.3° F. is 80 per cent. saturated and would exert a pressure of

$$0.527 \times 0.80 = 0.422 \text{ lbs. per sq. in.}$$

and therefore the moisture per cubic foot of air under atmospheric conditions would be

$$\frac{0.422}{14.686} = 0.0287 \text{ cu. ft.}$$

Now the air and gas are not under the same conditions of pressure and temperature and the 1.0739 cu. ft. of air above computed must be reduced to the same pressure and temperature as the atmosphere. The pressure on the gas is

$$14.748 - 0.436 = 14.312 \text{ lbs.}$$

and the air pressure is

$$14.686 - 0.422 = 14.264 \text{ lbs.}$$

The temperatures are 75.5° F. for the gas and 81.3° F. for the air.

The amount of air if reduced to the conditions of atmosphere will be:

$$1.0739 \times \frac{81.3 + 460}{75.5 + 460} \times \frac{14.312}{14.264} = 1.09 \text{ cu. ft.}$$

The mixture entering the engine with 1 cu. ft. of gas and its molecular weight are given below:

Gas.....	1.000 cu. ft.
Air.....	1.074 cu. ft.
H ₂ O.....	$\left\{ \begin{array}{l} \text{gas} \dots\dots\dots 0.030 \text{ cu. ft.} \\ \text{air} \dots\dots\dots 0.031 \text{ cu. ft.} \end{array} \right.$
Total.....	

The products of combustion per cubic foot of gas and the computation for the mean molecular weight are given below:

	Volume	V × mol. wt.		
CO.....	0.0045.....	0.126		
N ₂	1.2464.....	35.000		
Air.....	0.2100.....	6.02		
H ₂ O.....	$\left\{ \begin{array}{l} 0.0809 \\ 0.0300 \\ 0.0310 \end{array} \right\}$	2.67		
CO ₂			0.3074.....	13.43
Total.....			1.9112.....	57.246

$$\text{Mean molecular weight} = \frac{57.246}{1.9112} = 30.1$$

The values of the specific heats for the burned mixture are given below:

Gas	Value of a	
CO.....	0.0045×0.018	$= 0.000081$
N ₂	1.2464×0.018	$= 0.022500$
Air.....	0.2100×0.018	$= 0.003780$
H ₂ O.....	0.1429×0.0188	$= 0.002690$
CO ₂	0.3074×0.0202	$= 0.006280$
		<u>0.035331</u>

Gas	Value of b	
CO.....	$0.0045 \times 0.185 \times 10^{-5}$	$= 0.0083 \times 10^{-5}$
N ₂	$1.2464 \times 0.185 \times 10^{-5}$	$= 0.2320 \times 10^{-5}$
Air.....	$0.2100 \times 0.185 \times 10^{-5}$	$= 0.0388 \times 10^{-5}$
H ₂ O.....	$0.1429 \times 0.668 \times 10^{-5}$	$= 0.1950 \times 10^{-5}$
CO ₂	$0.3074 \times 0.807 \times 10^{-5}$	$= 0.2460 \times 10^{-5}$
		<u>0.7201 $\times 10^{-5}$</u>

$$a = \frac{0.035331}{1.9112} = 0.01831$$

$$b = \frac{0.7201 \times 10^{-5}}{1.9112} = 0.3762 \times 10^{-5}$$

From this the heat in the exhaust gases at 752.6° F. above 75.5° F. is

$$\begin{aligned} \text{Heat} &= V \int C_p dt = V[a(T_2 - T_1) + \frac{b}{2}(T_2^2 - T_1^2)] \quad (55) \\ &= 1.9112[0.01831(752.6 - 75.5) + \frac{0.3762 \times 10^{-5}}{2}(752.6^2 - 75.5^2)] \\ &= 1.9112[12.398 - 1.052] \\ &= 25.70 \end{aligned}$$

Heat in exhaust gases at 75.5° F. due to evaporation of water:

Volume of H₂O = 0.1429 cu. ft.

$$\text{Weight of H}_2\text{O} = \frac{0.143 \times 14.7 \times 144}{\frac{1544}{18} \times 535.5} = 0.0066.$$

Heat of vaporization = 1049 \times 0.0066 = 6.92 B.t.u.

Total heat in exhaust gases per cu. ft. = 32.62 B.t.u.

Heat of combustion in carbon monoxide in exhaust gas

$$0.0045 \times 337 = 1.518 \text{ B.t.u.}$$

Heat Balance per cu. ft. of gas:

Heat supplied.....	120.20
Heat brought in above 75.5° F. by air =	
1.070[81.3 - 75.5][0.018]	0.11
Moisture in gas and air = $\frac{6}{143} \times 2.67$	<u>1.15</u>
Total Heat Supplied.....	121.46

Heat in indicated useful work (28.1 per cent.).....	33.8 B.t.u.	27.8%
Heat in jacket water (30.9 per cent.)	36.2	29.8
Heat in exhaust gases.....	{ 25.70 6.92	26.8
Heat in CO.....	1.52	1.3
Difference.....	<u>18.96</u>	<u>14.3</u>
		100.0%

COMBUSTION OF FUELS FOR BOILERS

The **combustion** of other fuels may be considered at this point with advantage. This combustion is practically the same as that of gases considered earlier. This union of the elements with oxygen develops heat. The heat of combustion and the air required are found in the table on p. 377 as was done for gases. The solid and liquid fuels are composed primarily of carbon, hydrogen, oxygen and sulphur.,

The **solid fuels** are **coal, lignite, peat, wood** and certain waste materials such as **bagasse**. These differ in their chemical composition. This composition is found by chemical analysis. When the analysis is made in a combustion tube giving the percentages of the various constituents, the analysis is called an **ultimate analysis**. If, however, the analysis gives only the moisture, volatile matter, fixed carbon and ash, it is known as a **proximate analysis**. This analysis is easily made and is the one made by engineers to place a coal. The analysis is given in percentages of the various constituents as **received** and on a **dry basis**, eliminating the moisture. This latter is necessary to reduce the effect of the variable moisture to zero. The results of analyses are given below:

ANALYSIS ON DRY BASIS

	Ultimate analysis						Proximate analysis			Heat Value
	C	H	O	N	S	Ash	Fixed C	Vol. matter	Ash	
Anthracite.....	88.0	2.0	2.0	0.8	0.50	6.7	85	7.00	8.00	13,750
Semi Bituminous.....	81.0	4.8	4.0	1.5	0.75	7.95	73	20.00	7.00	14,700
Bituminous.....	75.0	5.0	9.0	1.5	1.5	8.00	56	36.00	8.00	13,800
Lignite.....	65.0	4.5	20.0	1.0	1.5	8.00	44	48.00	8.00	10,700
Peat.....	61.0	6.0	28.10	1.9	3.0	9,000
Wood.....	51.0	7.6	4.0	37.0	0.4	9,000

At times the analysis is put on an **ash- and moisture-free basis**. This is expressed in percentages of the constituents with ash and moisture omitted.

The constituents unite with the oxygen according to the formulæ

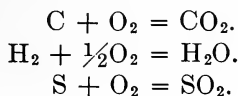

From the atomic weights of the elements, the weights of the oxygen required per pound of carbon, hydrogen or sulphur may be found, together with the products of combustion. Thus 1 lb. of carbon requires $3\frac{1}{2}$ lbs. of oxygen, 1 lb. of hydrogen requires $1\frac{1}{2}$ or 8 lbs. of oxygen and $3\frac{1}{2}$ lb. of oxygen are required per pound sulphur. If these quantities are divided by 0.232 the air required per pound of the various substances is known. If C , H and S represent the parts of these substances in 1 lb. of fuel, the **air required** is given by:

$$\text{Lbs. of air per lb. fuel} = 11.5 C + 34.5 H + 4.35 S.$$

This is given also as:

$$\text{Lbs. of air} = 11.5 C + 34.5 \left(H - \frac{O}{8} \right) + 4.35 S.$$

or approximately

$$\text{Lbs. of air} = 12 C + 36 \left(H - \frac{O}{8} \right).$$

The value $\frac{O}{8}$ is subtracted from H if O is the weight of the oxygen in the fuel, since it is assumed that this oxygen is united with the proper amount of hydrogen in the form of H_2O .

The **heat of combustion** has been given by **Dulong**.

$$\text{Heat per pound} = 14,650C + 62,100 \left(H - \frac{O}{8} \right) \quad (56)$$

The value given by this formula is approximately that given by the bomb calorimeter. The results of burning determined by a calorimeter are given in the table on p. 402.

The products of combustion of solid fuels are principally CO_2 , N_2 and excess air. If pure carbon is burned, the CO_2 formed is just equal in volume to the oxygen consumed, so that the maximum amount of CO_2 is 21 per cent. by volume. As there is some hydrogen present and as the water occupies twice the volume of oxygen consumed, each per cent. of hydrogen reduces the percentage CO_2 because, although the water condenses, the nitrogen of the air left from its burning cuts down the possible percentage. As soon as oxygen appears in the burned gases it indicates that excess air has been supplied. This is advisable in

many cases as there is danger in having some CO when the air is not in excess and the loss due to improper combustion is greater than that due to the presence of excess air. This latter represents a loss due to a larger quantity of hot gas sent from a boiler or gas engine. It is shown that at least a 30 per cent. excess is necessary to prevent the formation of CO. The curve of Fig. 189 illustrates the relation between per cent. CO₂ and total air supply as a per cent. of the theoretical air supply. It is found that when the per cent. CO₂ is between 10 and 15 per cent. the best results are obtained.

In analyzing gases from furnaces a percentage of CO₂ of 15 per cent. with 3 or 4 per cent. of O₂ represents good results.

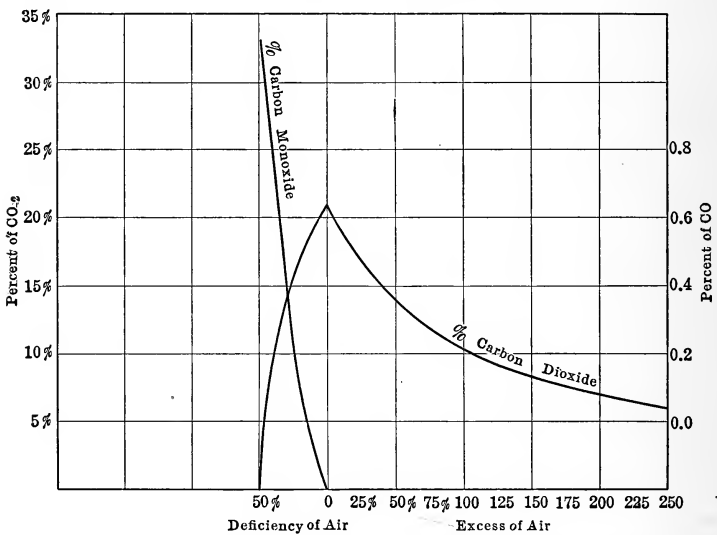

FIG. 189.—Curve of relation between per cent. CO₂ and excess of air.

PROBLEM

The analysis of the exhaust gases from a boiler gives the exact excess air. Thus for a coal of the following analysis:

Per Cent. by Weight	
C.....	80.0
H ₂	5.0
O ₂	10.0
S.....	0.5
Ash.....	4.5
	100.0

and flue gases of the following analysis:

Per Cent. by Volume	
CO ₂	12.0
CO.....	0.5
O ₂	5.0
N ₂	82.5

The amount of air may be worked out. The oxygen and carbon in the exhaust gas may be found by remembering that from Avogadro's Law, equal volumes at the same temperature and pressure contain equal numbers of molecules. Hence each volume may be considered to contain one molecule. The weights of carbon and oxygen of the gas are found as follows:

$$\begin{aligned} \text{Carbon from CO}_2 &= 0.12 \times 12 = 1.44 \\ \text{Carbon from CO} &= 0.005 \times 12 = \underline{0.06} \\ \text{Total carbon} &\dots\dots\dots 1.50 \end{aligned}$$

$$\text{Per cent. carbon burned to CO}_2 = \frac{1.44}{1.50} = 96 \text{ per cent.}$$

$$\text{Per cent. carbon burned to CO} = \frac{0.06}{1.50} = 4 \text{ per cent.}$$

$$\begin{aligned} \text{Oxygen from CO}_2 &= 0.12 \times 32 = 3.84 \\ \text{Oxygen from CO} &= 0.005 \times 16 = 0.08 \\ \text{Oxygen from O}_2 &= 0.05 \times 32 = \underline{1.60} \\ \text{Total oxygen required} &\dots\dots\dots 5.52 \end{aligned}$$

$$\text{Oxygen per lb. carbon} = \frac{5.52}{1.50} = 3.68$$

$$\text{Pounds excess of oxygen supplied per pound carbon} = \frac{1.60}{1.50} = 1.067$$

Per cent. excess of oxygen in total oxygen shown by analysis =

$$\frac{160 \times 100}{552} = 29 \text{ per cent.}$$

The gas analysis does not show the oxygen required for the hydrogen and sulphur and these must be added to that for the carbon and from the same the oxygen of the coal is subtracted. The oxygen required is given by:

Oxygen for carbon as burned and excess		
oxygen per pound coal.....	= 0.80 × 3.68	= 2.944
Oxygen for hydrogen.....	= 0.05 × 8.0	= 0.400
Oxygen for sulphur to SO ₂	= 0.005 × 1.0	= <u>0.005</u>
		3.349

Oxygen in coal.....	0.100
Net oxygen per pound coal.....	<u>3.249</u>

$$\text{Air per pound coal} = \frac{3.249}{0.232} = 13.95$$

$$\text{Excess of air in total air supplied} = \frac{0.29 \times 2.944}{3.249} = 26.25 \text{ per cent.}$$

Products of Combustion :

Carbon dioxide.....	0.8	$\times 0.96 \times \frac{44}{12}$	= 2.810
Carbon monoxide.....	0.8	$\times 0.04 \times \frac{28}{12}$	= 0.075
Water vapor.....	0.05	$\times 9$	= 0.450
SO ₂	0.005	$\times 2$	= 0.010
Excess air	1.067	$\times 0.80 \times \frac{1}{0.232}$	= 3.670
Nitrogen.....	(13.95 - 3.67)	0.768	= 7.890
Ash.....			= 0.045
			= 14.950

This checks the 1 lb. of coal and the 13.95 lbs. of air.

The **moisture brought in by the air** may be treated in the same manner as that used in the problem of p. 400. The **heat carried up the stack** may be computed in a manner similar to that used in finding the heat in the exhaust gases of a gas engine. This quantity when divided by the heat of combustion of coal gives the percentage loss in the stack. This amounts to about 10 or 15 per cent. when there is just sufficient air, while with 100 per cent. excess it amounts to 20 per cent. A deficiency of air means a loss due to incomplete combustion. After the carbon burns to CO₂ a further passage through a bed of hot coals changes the CO₂ to CO and the water from the burning of the hydrogen may be dissociated. On mixing the CO with hot air and having the H₂ and O mix after cooling, in the presence of a flame the gases burn and give out their heat of combustion. With an insufficient or a cold air supply above the fire the CO may not burn. If volatile hydrocarbons are driven off in the form of smoke these must be mixed with air in the presence of incandescent fuel to prevent smoke formation.

SURFACE COMBUSTION

To cause gas to burn completely with the theoretical amount of air present or a little above the requisite amount of air the method of **surface combustion** has been suggested. In this a **mixture of gas and air** is delivered into a tube of a burner and discharged into a receptacle filled with small pieces of refractory material. If the mixture is lighted and its velocity through the tube is more rapid than the speed of burning, the flame will

not enter the tube and cause an explosion but the mixture will quietly burn and heat the refractory material to brightness unless the heat is removed by some method. Fig. 190 illustrates one form of burner. In the **Bone-Schnabel boiler** this method is applied, the combustion taking place in the boiler flues which are either filled with small pieces of a refractory substance or rods of the same. The heat of combustion then heats these substances so that the heat is transmitted to the tube surface by radiation and by conduction so readily that not only is the capacity increased but the efficiency is greatly increased due to the low temperature of the exhaust.

The combustion is complete. In tests quoted in the Journal of the A.S.M.E. for Jan., 1914, p. 09, G. Neuman reports a test on one of these boilers showing an evaporation of 16.4 to 30.75 lbs. per square foot of surface and an efficiency of 90 per cent.

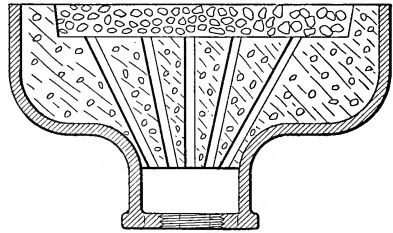

FIG. 190.—Burner for surface combustion.

The porous filling not only causes the gas to move at a higher velocity relative to the tube but these heated objects maintain combustion and thoroughly mix the gas and air preventing stratification.

TOPICS

Topic 1.—Sketch the cycles of Beau de Rochas, Atkinson, Otto, Lenoir, and Diesel. Explain the action on each line and reduce expressions for the thermal efficiency of each cycle.

Topic 2.—From the efficiency of the Otto cycle on the air standard

$$\eta_3 = 1 - \frac{T_2 - T_b}{T_d - T_c}$$

Reduce the expressions

$$\eta_3 = 1 - \frac{T_b}{T_c} = 1 - \left(\frac{V_c}{V_b}\right)^{k-1} = 1 - \left(\frac{1}{1 + \frac{1}{l}}\right)^{k-1}$$

Give reasons for the impossibility of reducing the expressions for efficiency of the other cycles by this method. What is meant by air standard?

Topic 3.—Explain the action of a four-cycle gas engine and a two-cycle oil engine. Draw cards from each. Explain how these engines are governed. Explain the methods of ignition.

Topic 4.—What affects the rapidity of combustion? Draw an indicator card showing slow burning. Sketch a curve showing the variation of gas temperature in a four-cycle gas engine. Is there much cyclic change in the metal of the cylinder walls?

Topic 5.—Mention the various fuels used in internal combustion engines. Give some of the peculiarities of each. What are gas producers? What are the two general types? Sketch one of them.

Topic 6.—Derive the expressions for finding the amount of oxygen and air to burn a cubic foot and a pound of C_2H_4 together with the expressions for the products of combustion. Show how to find the heat per cubic foot if the heat per pound is 21,400 B.t.u. Find the specific heats per cubic foot if $c_p = 0.404$ and $c_v = 0.340$. On what laws are these based?

Topic 7.—Derive the formulæ

$$B = \frac{1544}{\text{mol. wt.}}$$

$$\text{Mol. wt.}_{\text{mix.}} = \frac{\Sigma \text{ mol. wt.} \times \text{vol.}}{\Sigma \text{ vol.}}$$

Topic 8.—Derive the formulæ for finding the temperatures at the corner of the Otto cycle assuming the value of c_v to be a constant.

Topic 9.—Derive the equation for the adiabatic of a gas when $c_v = a' + bT$. Derive the equation for n on this line in terms of the temperatures.

Topic 10.—Explain the method of finding temperature at the ends of compression and expansion.

Topic 11.—Explain by formulæ the method of finding the temperature after explosion.

Topic 12.—Explain the construction of the T - s diagram for the gas engine deriving the expressions for the construction of the figure.

Topic 13.—Explain the construction of the logarithmic diagram of the gas-engine card. What data can be found from this card? What data must be known to construct the card?

Topic 14.—Explain the method of finding the amount of dilution from the analyses of the fuel gas and exhaust gas.

Topic 15.—Explain the method of finding the efficiency of a producer.

Topic 16.—Explain the method of finding the heat loss in the exhaust gases and in the jacket water.

Topic 17.—Explain the method of finding the heating value of a gas from its chemical composition. Explain how to find the heat equivalent of the work.

Topic 18.—Explain how to find the amount of air per pound of fuel in a boiler test from the coal analysis and gas analysis. What is Dulong's formula? What is surface combustion? Explain the construction of the Bone-Schnabel boiler.

PROBLEMS

Problem 1.—The clearance of an engine is 30 per cent. of its longest stroke. The initial temperature is 150° F. The heat per cubic foot of mixture

is 70 B.t.u. The radiation loss during explosion is 35 per cent. Find the temperatures at the corners of Otto cycle and Atkinson cycle assuming the air standard. Find the Carnot efficiency of each, the theoretical efficiency and the type efficiency.

Problem 2.—A Diesel engine has a final pressure of 600 lbs. per square inch. What is the clearance to give this from atmospheric pressure at the beginning of the stroke ($n = 1.38$). If the original volume including clearance is 1 cu. ft. of air at 160° F., find the weight of crude oil given in this chapter which could be burned by this air with 25 per cent. dilution. If 75 per cent. of the heat is available find the temperature and volume after burning, using the air standard.

Problem 3.—Find the products of combustion of 1 lb. of crude oil burned in a Diesel engine with 15 per cent. dilution. Find the temperature resulting therefrom with a 25 per cent. loss to the jacket considering the actual composition of the gas and assuring the pressure constant.

Problem 4.—Find the temperature T_1 if the clearance is 30 per cent. and the gas and air outside has a temperature of 60° F. with c_v per cubic foot 0.014 and the heat per cubic foot 78 B.t.u. Find the other temperatures assuming 20 per cent. loss to jacket.

Problem 5.—Assume a blast-furnace gas of form given in this chapter mixed with 10 per cent. excess air. Find the cubic feet of air per cubic foot of gas. Find the value of T_2 considering the actual composition of the mixture if $T_1 = 600^\circ$ abs. and the clearance is 25 per cent. Find T_3 with 10 per cent. loss. Find T_4 .

Problem 6.—Sketch an indicator card from an engine with 25 per cent. clearance and draw the T - s diagram and logarithmic diagram. Find the heat added if the actual efficiency is 28 per cent. Find the scales of the figure if T_1 is found to be 125° F. What is the maximum value of T_1 .

Problem 7.—The following results are obtained from a test:

Coal	Producer Gas	Exhaust Gas
C.....80.0 per cent.	CO ₂ 4.0 per cent.	Co ₂15.8 per cent.
CH ₂ 6.0 per cent.	O ₂ 0.5 per cent.	O ₂ 2.5 per cent.
H ₂ 0.5 per cent.	CO.....25.5 per cent.	CO..... 0.2 per cent.
Ash.....10.0 per cent.	H ₂ 5.0 per cent.	N ₂81.5 per cent.
Moisture 3.5 per cent.	CH ₄ 1.8 per cent.	
	N ₂63.2 per cent.	
100.0	100.0	100.0
Time of test..... 1,200 min.	Exhaust temperature.	800° F.
Revolutions.....240,000	Jacket temperature	70°
Explosions.....110,000	Jacket temperature...	120°
Gas pressure..... 2 in. water	Coal.....	4,000 lbs.
Barometer..... 29.9 in.	Gas.....	320,000 cu. ft.
Gas temperature... 80° F.	I.h.p.....	200
Air temperature... 70° F.	B.h.p.....	160
Relative humidity . 60 per cent.	Cooling water.....	178,000 lbs.

Compute the various losses and efficiencies and make a heat balance.

Problem 8.—The heating value of 1 lb. of coal as fired is 14,680 B.t.u.

The equivalent evaporation from and at 212° F. per pound of coal is 11.10 lbs. Find the efficiency of the boiler.

Problem 9.—In Problem 8 the following was found: The flue gas analysis by volume gave 0.18 per cent. CO, 6.49 per cent. CO₂, 13.09 per cent. O₂, and the coal analysis by weight was as follows:

Moisture.....	1.0 per cent.
Ash.....	6.9
Hydrogen.....	2.8
Oxygen.....	4.2
Carbon.....	83.0
Sulphur.....	0.8
Nitrogen.....	1.3
	100.0

Find the amount of air per pound of coal. Find the excess air. Find the heat value by Dulong's formula and check with value by calorimeter given in Problem 8.

Problem 10.—In Problem 9 find the composition of the exhaust gases per pound of coal assuming that the air at a temperature of 75° F. has a wet bulb temperature of 67° F.

Problem 11.—With the results of Problem 10 find the heat carried away in the flue gases due to a temperature of 427° F. and the heat available from the CO present. Express these as percentages of 14,680 B.t.u.

Problem 12.—With coal at \$4.40 per ton what is the cost of producing 1000 lbs. of equivalent evaporation, using data of Problem 8. Equivalent evaporation from and at 212° F. is equal to the actual evaporation multiplied by the factor of evaporation. Factor of evaporation is the amount of steam evaporated from and at 212° F. by the same amount of heat as will evaporate 1 lb. of water at the given feed temperature into steam at the given condition for the boiler. This is given

$$f = \frac{q'_1 + x_1 r_1 - q'_0}{r_{212}} = \frac{i_1 - q'_0}{r_{212}}$$

In this problem find the factor of evaporation for a gauge steam pressure of 121.3 with the barometer of 29 in. if the feed temperature is 105° F. and the quality of the steam is 65° F. superheat. Find the cost of producing 1000 lbs. of actual steam.

CHAPTER X
REFRIGERATION
AIR MACHINES

The refrigerating machine operates by placing a substance in such a condition that its temperature is above the temperature of a water supply, and after the removal of heat from the substance by this supply the condition of the substance is so changed that it will abstract heat from a body of

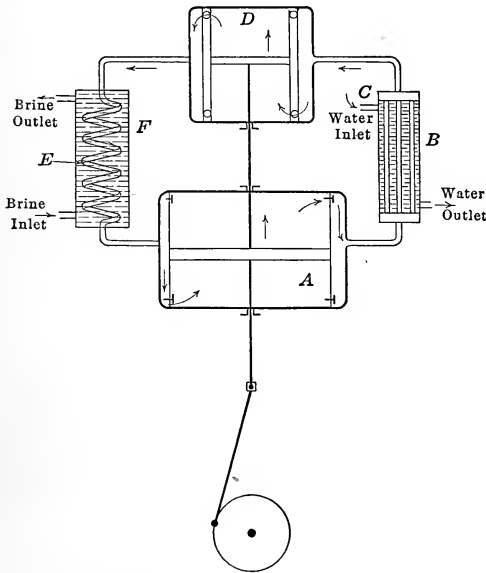

FIG. 191.—Air refrigerating machine.

low temperature. The temperature of the substance is changed by changing the pressure on the substance. This is accomplished by machines in which a gas such as air or a vapor such as ammonia or carbon dioxide is used. The **air machine** is shown in Fig. 191. Air is compressed in the cylinder *A* from a pressure p_1 to a pressure p_2 . At the pressure p_2 it is discharged through a

pipe system *B* which is cooled by water from the supply *C*. In this case the cooling of the air reduces its volume so that when this air is taken to a second cylinder *D* it occupies less space. The air is then allowed to expand in the cylinder *D* to the original pressure, doing work at expense of its intrinsic energy, and hence its temperature falls so much that on entering the coil *E* in the tank or room *F*, this air will remove heat from the brine in the tank or from the air, if placed in a room. This air is taken back to the compressor after removing heat from the room *F*. The cycle is shown in Fig. 192. At times the air is discharged into the room *F* instead of passing through the coil and air is sucked from the room. The system is then called an **open system** to distinguish it from that of Fig. 191 which is called a **closed system**.

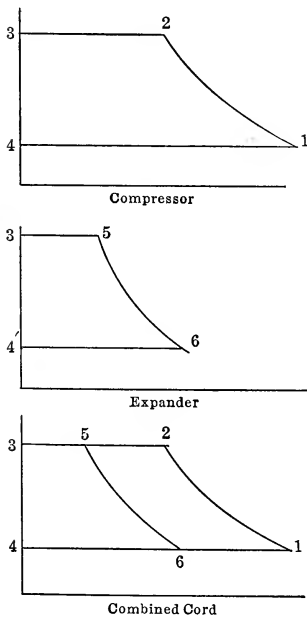

FIG. 192.—Cycle of the air machine.

water at the point of discharge of the air. In a countercurrent cooler this may be less than the temperature of the outlet water. It is about 10° F. above the temperature of the water at the point. When this air passes into the expansion cylinder its volume will be shown by the point 5. The admission line is 3-5. The air expands to the lower pressure and its condition is shown by point 6. This action is also adiabatic, so that

If the temperature of the air sucked from the cool room *F* is T_1 and the pressure is p_1 , the condition of 1 lb. of air is shown by the point 1; the volume 4-1 is sucked in on the line 4-1 if clearance is neglected. This air is compressed along the line 1-2 and the line is practically an adiabatic. The temperature T_2 is given by

$$T_2 = T_1 \left(\frac{p_2}{p_1} \right)^{\frac{k-1}{k}} \quad (1)$$

This air occupies the volume 3-2 and the card 4123 represents the work done on the compressor *A*. The air is forced out and is cooled off in the cooler *B* to a temperature T_3 fixed by the temperature of the

$$T_6 = T_5 \left(\frac{P_1}{P_2} \right)^{\frac{k-1}{k}} \quad (2)$$

or

$$\frac{T_5}{T_6} = \frac{T_2}{T_1} \quad (3)$$

$$T_6 = T_5 \frac{T_1}{T_2} \quad (4)$$

It is thus seen that T_1 is fixed by the temperature of the refrigerator, being the room temperature in the case of an open system or 10° to 15° F. less for a closed system; while T_5 is fixed by the temperature of the cooling water, T_2 and T_6 are fixed by the pressure ratios after T_1 and T_5 are found.

The work done on the compressor is 4123 while that done by the air in the motor is 3564. The difference or 1256 shown by combining the cards is the net work required. This work is also the difference between the heat on the top and bottom lines since there is no heat on the curved lines.

$$AW = c_p \{ [T_2 - T_5] - [T_1 - T_6] \} \quad (5)$$

It is seen that heat removed by the cooler is equal to the heat removed from the refrigerator plus the work done on the substance.

But the heat to change the volume from 2 to 5 is the heat removed by the cooling water while that added from 6 to 1 is that taken from the refrigerator. Hence

$$Q_{ref.} = c_p [T_1 - T_6] \quad (6)$$

and

$$Q_{cooler} = c_p [T_2 - T_5] \quad (7)$$

The efficiency or better the refrigerative performance is the amount of refrigeration per unit of work. This is given by

$$\eta_r = \frac{c_p [T_1 - T_6]}{c_p \{ [T_2 - T_5] - [T_1 - T_6] \}} \quad (8)$$

$$\eta_r = \frac{1}{\frac{T_2 - T_5}{T_1 - T_6} - 1}$$

But

$$\frac{T_2 - T_5}{T_1 - T_6} = \frac{T_2}{T_1} = \frac{T_5}{T_6}$$

since

$$\frac{T_5}{T_6} = \frac{T_2}{T_1}$$

and

$$\frac{T_5}{T_2} = \frac{T_6}{T_1}$$

Hence

$$\eta_r = \frac{1}{\frac{T_2}{T_1} - 1} \text{ or } \frac{1}{\frac{T_5}{T_6} - 1} \quad (9)$$

$$= \frac{T_1}{T_2 - T_1} \text{ or } \frac{T_6}{T_5 - T_6} \quad (10)$$

These expressions are equal to the lower temperature on one of the adiabatics divided by the difference in temperature on that adiabatic. The expression is greater than unity.

The **refrigeration** produced by any machine is usually **measured in tons of refrigeration per 24 hrs.** The amount of heat liberated when 1 lb. of ice melts is 144 B.t.u. (best value 143.5 B.t.u.), and hence the heat equivalent to 1 ton of refrigeration is 288,000 B.t.u. in 24 hrs. which is 200 B.t.u. per minute. The number of **pounds of air required** for this refrigeration is

$$\text{Lbs. of air per min. per ton in 24 hrs.} = \frac{200}{c_p[T_1 - T_6]} = M_a \quad (11)$$

The **amount of cooling** by the air cooler is

$$Q_c = M_a c_p [T_2 - T_5] \quad (12)$$

The **water required** for this is given by

$$M_w = \frac{M_a c_p [T_2 - T_5]}{q'_o - q'_i} \quad (13)$$

M_w = weight of cooling water per min. per ton in 24 hrs.

q'_o = heat of liquid of cooling water at outlet temperature t_o

q'_i = heat of liquid of cooling water at inlet temperature t_i .

The **horse-power** required for the production of 1 ton per 24 hrs. is

$$\text{h.p.} = M_a c_p [T_2 - T_5 - (T_1 - T_6)] \frac{778}{33000} \quad (14)$$

$$= \frac{Q_r}{\eta_r} \times \frac{778}{33000} \quad (15)$$

$$= [Q_c - Q_r] \frac{778}{33000} \quad (16)$$

The **volume of the compressor** is V_1 while that for the **expansion cylinder** is V_6 . These are each given by

$$V_1 = \frac{M_a B T_1}{p_1} \text{ or } \frac{M_a B T_1}{p_1 \times \text{cl. factor}} \quad (17)$$

$$V_6 = \frac{M_a B T_6}{p_6} \text{ or } \frac{M_a B T_6}{p_6 \times \text{cl. factor}} \quad (18)$$

The above equations are computed for cylinders **without clearance and friction**, for **non-conducting cylinder walls** and for **dry air**. These three things affect the results of computations, but because their effects are seen by comparison with perfect conditions the equations for perfect conditions are given although not used in practice.

PROBLEM

Assume that a 3-ton machine was desired to operate between 14.7 lbs. abs. and 58.8 lbs. abs. and that the temperatures of the cooling water were 50° F. to 65° F. and that for the cool room was 25° F. It will be assumed further that the air from the expansion cylinder is discharged into the room to be refrigerated. From the above the following is true:

$$T_1 = 25^\circ \text{ F.} = 485^\circ \text{ abs.}$$

$$T_5 = 50^\circ + 15^\circ = 65^\circ \text{ F.} = 525^\circ \text{ abs.}$$

(assuming a counter-current flow)

$$T_2 = 485 \left(\frac{58.8}{14.7} \right)^{\frac{0.4}{1.4}} = 485 \times 1.486 = 720^\circ \text{ abs.} = 260^\circ \text{ F.}$$

$$T_6 = 525 \times \frac{485}{720} = 354^\circ \text{ abs.} = -106^\circ \text{ F.}$$

$$\eta_r = \frac{485}{720 - 485} = 2.063$$

$$Q_r = 200 \times 3 = 600 \text{ B.t.u. per min.}$$

$$M_a = \frac{600}{0.24[485 - 354]} = 19.08 \text{ lbs. of air per min.}$$

$$Q_{\text{cooler}} = 19.08 \times 0.24[720 - 525] = 892 \text{ B.t.u. per min.}$$

$$\text{H.p.} = (892 - 600) \frac{778}{33000} = 6.86$$

also
$$\text{H.p.} = \frac{600}{2.063} \times \frac{778}{33000} = 6.85$$

The water required is

$$M_w = \frac{892}{33.1 - 18.1} = 59.4 \text{ lbs. per min.}$$

Displacements per minute are:

$$V_{\text{comp.}} = \frac{19.08 \times 53.35 \times 485}{14.7 \times 144} = 233 \text{ cu. ft. per min.}$$

$$V_{\text{exp.}} = \frac{19.08 \times 53.35 \times 354}{14.7 \times 144} = 170 \text{ cu. ft. per min.}$$

The machine considered in the problem above is one in which the discharge has been into an open space. Such a system may be called an **open system**. If now the discharge takes place in a closed pipe line (**the closed system**) it would be possible to have the pressure p_1 higher than atmospheric pressure. Suppose that p_1 is made 58.8 lbs. abs. and p_2 , 235.2 lbs. abs. so

that the ratio $\frac{p_2}{p_1}$ is the same as before. If under these conditions the above problem is computed the results will be the same except the displacements which will be one-fourth of their former values. This is due to the higher pressures. This "**dense air machine,**" as it is called, is used because it decreases the displacement of the cylinders and hence the size or speed of the machine. This is the only reason for its use.

The problems must now be **investigated for clearance and friction.** Since friction increases the work of the compressor and decreases the work obtained from the expansion cylinder, the work done by each of these machines must be considered separately, instead of obtaining the net work 1256 as before.

The work of the compressor 1234 is the same with or without clearance. It is equal to

$$\begin{aligned} W_{comp} &= \frac{n}{n-1} p_1 V_1 \left[1 - \left(\frac{p_2}{p_1} \right)^{\frac{n-1}{n}} \right] \\ &= \frac{n}{n-1} [p_1 V_1 - p_2 V_2] = \frac{n}{n-1} MB [T_1 - T_2]. \end{aligned} \quad (19)$$

If $n = k$ this becomes

$$W_{comp} = MJc_p [T_1 - T_2] \quad (20)$$

To make this work as small as possible, jackets may be used on the cylinder changing k to n and making n as low as 1.38.

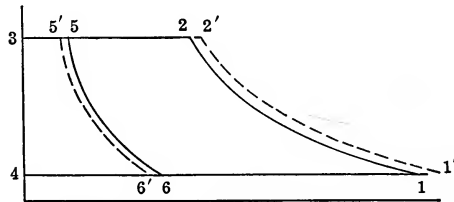

FIG. 193.—Effect of friction in air machines.

If the **friction fraction** is f , the work must be multiplied by $(1 + f)$ or

$$1'2'34 = \text{work of compression} = (1 + f) \frac{n}{n-1} MB [T_1 - T_2] \quad (21)$$

For the expansion cylinder the work obtained is $(1 - f')$ times the work without friction. This work is independent of the

clearance if the expansion and compression are each complete. The work then becomes:

$$35'6'4 = \text{work of expansion} = (1 - f')p_6V_6 \frac{k}{k-1} \left[1 - \left(\frac{p_2}{p_1} \right)^{\frac{k-1}{k}} \right]$$

or

$$\text{work} = (1 - f')MJc_p[T_5 - T_6] \quad (22)$$

The **value of n** in the expansion cylinder is k as it is desired to have as low a value of T_6 as possible and this is accomplished by having as large a value of n as possible. By lagging the expansion cylinder and omitting any jacket this n is made k as no heat is taken away.

The difference of the two expressions for work will give the work required from the outside to drive the machine.

Of course with n on compression (1.38) different from that on expansion (1.4) the equality of cross products

$$T_1T_5 = T_2T_6$$

is not true. T_2 and T_6 must each be found.

$$T_2 = T_1 \left(\frac{p_2}{p_1} \right)^{\frac{n-1}{n}} \quad (23)$$

$$T_6 = T_5 \left(\frac{p_1}{p_2} \right)^{\frac{k-1}{k}} \quad (24)$$

The **effect of clearance air** on the temperatures is important to consider. The air left in the cylinder at the end of compression is at a temperature T_2 . When this expands down to atmospheric pressure the temperature is T_1 so that the fresh air entering at this temperature mixes with it. In the expander the air in the clearance space at temperature T_6 is compressed to the temperature T_5 by complete compression and so mixes with air from the cooler at that temperature. If this compression were not complete this temperature T_5 would not be reached and the effect of this would be to give a different temperature of the mixture at the beginning of expansion. This incomplete compression would require an excess amount of air from the supply to fill the clearance space. This free expansion into the clearance space would warm the air in the cylinder and produce a higher temperature at the beginning and at the end of expansion. It would mean a decrease in refrigerating effect and would also decrease the work obtained from the expander per pound of air used.

If the **expansion were incomplete** the temperature at the end of expansion would not be as low as T_6 due to the pressure range $\frac{p_5}{p_6'}$ being less than $\frac{p_5}{p_6}$ or $\frac{p_2}{p_1}$ and as a result the temperature at the end of free expansion or the discharge temperature would be higher than T_6 . This reduces the refrigerating effect. The work obtained from a given amount of air has been decreased by the incomplete expansion and compression. For these two reasons the performance is decreased by a very material amount and the endeavor is made to have complete expansion and compression.

To **eliminate the effect of clearance** the compression in the expansion cylinder is such that the pressure at the end of compression is equal to pressure of the compressor and the expansion is carried down to the back pressure. The action is then equivalent to a cylinder without clearance.

The **moisture in the air** has an effect on the efficiency of air refrigerating machines. The compression of moist air may cause some of the moisture to condense giving out heat and warming the air while a further condensation and even freezing in the expansion cylinder causes the liberation of additional heat reducing the refrigerating effect. Air will be removed in short time.

Suppose that air of relative humidity ρ , temperature T_1 and pressure p_1 occupies the volume V_1 . The weight of the air is

$$M_a = \frac{(p_1 - \rho p_{t_1})V_1}{B_a T_1} \quad (25)$$

p_{t_1} = sat. steam pressure corresponding to t_1 .

The weight of the moisture M_m is

$$M_m = \rho m_1 V_1 \quad (26)$$

m_1 = weight of 1 cu. ft. of steam at temperature t_1 .

This may also be approximated by the formula

$$M_m = \frac{\rho p_{t_1} V_1}{B_m T_1} \quad (27)$$

$$B_m = \frac{1544}{\text{mol. wt. steam}} = \frac{1544}{18} = 85.8$$

For the complete mixture of air and moisture

$$(M_a + M_m) B_{mz} T = pV \quad (28)$$

After compression to the pressure p_2 the volume becomes

$$V_2 = V_1 \left(\frac{p_1}{p_2} \right)^{\frac{1}{k}} \quad (29)$$

and
$$T_2 = T_1 \left(\frac{p_2}{p_1} \right)^{\frac{k-1}{k}} \quad (30)$$

Now
$$\frac{M_m}{V_2} = \text{weight of moisture in 1 cu. ft.} \quad (31)$$

hence, if

$$\begin{aligned} m_2 &= \text{weight of 1 cu. ft. of saturated steam} \\ \frac{M_m}{m_2} &= \rho_2 = \text{relative humidity after compression} \end{aligned} \quad (32)$$

ρ_2 is usually less than unity because of the high temperature at the end of adiabatic compression.

The work of compression of the mixture of air and vapor is considered to be that of a perfect gas as the steam in the air is superheated. If adiabatic this becomes:

$$\begin{aligned} W_c &= \frac{k}{k-1} p_1 V_1 \left[1 - \left(\frac{p_2}{p_1} \right)^{\frac{k-1}{k}} \right] \\ &= \frac{1}{A} [M_a c_a + M_m c_m] (T_2 - T_1) \end{aligned} \quad (33)$$

c_a = specific heat at constant pressure for air.

c_m = specific heat at constant pressure for moisture.

$$c_m = \frac{1}{778} \times \frac{1544}{18} \times \frac{1.3}{0.3} = 0.48.$$

If this air is cooled in the cooling coil to a temperature T_3 , the moisture may or may not be sufficient to saturate the air. To find out the amount, it is known that

$$V_3 = V_2 \frac{T_3}{T_2} \quad (34)$$

and
$$\frac{M_m}{m_3} = \rho_3 \quad (35)$$

If
$$m_3 < \frac{M_m}{V_3} \quad (36)$$

$$M_m - m_3 V_3 = \text{amount condensed.}$$

If the moisture condensed is removed by a separator, the weight of the material left is

$$\begin{aligned} & M_a + m_3 V'_3 \\ \text{in place of} & M_a + M_m \end{aligned} \quad (37)$$

$$\text{The volume of this is } V'_3 = \frac{M_a B_a T_3}{(p_2 - p_{t3})} \quad (38)$$

The value of Q_c is

$$Q_c = M_a c_p [T_2 - T_3] + M_m c_{pm} [T_2 - T_3] + [M_m - m_3 V'_3] r_3 \quad (39)$$

The moisture which enters the expansion cylinder is practically all condensed and frozen by the cool walls of the cylinder liberating heat represented by C .

$$C = m_3 V'_3 [c_p (T_2 - T_{32}) + r_{32} + 144] \quad (40)$$

This is gradually restored during expansion.

The volume of the air remaining is

$$V''_3 = \frac{M_a B_a T_3}{p_2} \quad (41)$$

The air and ice in the cylinder now expand with the gradual return of the heat C from that produced by the ice formation giving:

$$M_a c_{va} dt + (m_3 V'_3) c_i dt + A p dv = + dC \quad (42)$$

$$\frac{M_a c_{va} + m_3 V'_3 c_i}{B} \frac{dt}{T} + M_a A \frac{dV}{V} = \frac{dC}{BT}$$

$$\text{assume } dC = - \frac{C}{T_3 - T_4} dt$$

$$\frac{M_a c_{va} + m_3 V'_3 c_i}{B} \log_e \frac{T_3}{T_4} + M_a A \log_e \frac{V_3}{V_4} = - \frac{C}{B(T_3 - T_4)} \log_e \frac{T_3}{T_4}$$

$$\frac{V_3}{V_4} = \left(\frac{p_4}{p_3} \right) \frac{T_3}{T_4}$$

$$\begin{aligned} [M_a c_{va} + m_3 V'_3 c_i + \frac{C}{T_3 - T_4} + M_a A B] \log_e \frac{T_3}{T_4} \\ = M_a A B \log_e \frac{p_3}{p_4} \end{aligned} \quad (43)$$

$$\text{Now } c_{va} + AB = c_p$$

Hence

$$\left(M_a c_p + m_3 V'_3 c_i + \frac{C}{T_3 - T_4} \right) \log_e \frac{T_3}{T_4} = M_a A B \log_e \frac{p_3}{p_4} \quad (44)$$

This is solved for T_4 by trial, knowing all the other terms. If $T_3 - T_4$ is assumed from an approximate value of T_4 from

$$T_4 = T_3 \left(\frac{p_4}{p_3} \right)^{\frac{k-1}{k}} \quad (45)$$

the equation leads directly to T_4

The value of T_4 then gives the heat taken from the refrigerator

$$Q_r = M_a c_p (T_4 - T_1) \quad (46)$$

The moisture is not considered at this point as it has been condensed and frozen in the expansion cylinder and does not enter the refrigerator.

The work done in the expansion cylinder is best found by the following:

$$W_e = p_3 V_3 + \int_{v_3}^{v_4} p dv - p_4 V_4 \quad (47)$$

From (42):

$$\begin{aligned} \int_{v_3}^{v_4} p dv &= - \frac{M_a c_{va} + m_3 V'_3 c_i + \frac{C}{T_3 - T_4}}{A} \int_{T_3}^{T_4} dt \quad (48) \\ &= \frac{1}{A} \left(M_a c_{va} + m_3 V'_3 c_i + \frac{C}{T_3 - T_4} \right) [T_3 - T_4] \end{aligned}$$

Since the moisture has been eliminated on the expansion curve

$$p_3 V_3 - p_4 V_4 = M_a B [T_3 - T_4] \quad (49)$$

and

$$B + \frac{c_v}{A} = \frac{c_p}{A} \quad (50)$$

$$\therefore W_2 = \frac{1}{A} \left(M_a c_p + m_3 V'_3 c_i + \frac{C}{T_3 - T_4} \right) [T_3 - T_4] \quad (51)$$

The work required from the outside is

$$(1 + f)W_e - (1 - f)W_c \quad (52)$$

and the refrigerating effect is

$$Q_r = M_a c_p (T_1 - T_4) \quad (53)$$

To apply the above formulæ assume that the air enters the compression cylinder at 25° F., with a relative humidity of 80 per cent. and is compressed to 4 atmospheres. The water in the cooler is sufficient to cool this to 65° F. Assume that $V_1 = 1$ cu. ft.

$$p_{2s}^{\circ} = 0.065$$

$$\rho p = 0.065 \times 0.8 = 0.052$$

$$M_a = \frac{[14.7 - 0.052] \times 144 \times 1}{53.34 \times 485} = 0.082 \text{ lbs.}$$

$$M_w = 0.8 \times 0.00023 = 0.00018; \text{ call this } 0.0002$$

$$\left(M_w = \frac{0.052 \times 144 \times 1}{85.8 \times 485} = 0.00018 \right)$$

This is a check.

$$V_2 = 1 \left(\frac{1}{4} \right)^{1.4} = 0.372$$

$$T_2 = 485 \times (4)^{0.4} = 720^{\circ} \text{ abs.} = 260^{\circ} \text{ F.}$$

$$\rho_2 = \frac{0.0002}{0.372} = 0.00054$$

$$\rho_2 = \frac{0.372}{0.085} = 0.0063.$$

or there is not enough moisture to saturate the air. The air is now cooled to 65° F. as in the problem on page 415.

$$V_3 = 0.372 \times \frac{525}{720} = 0.272$$

$$\rho_3 = \frac{0.0002}{\frac{0.272}{0.000979}} = \frac{0.000753}{0.000979} = 0.767$$

Hence none of the moisture is condensed in the cooling coil. If ρ_3 were greater than unity there would be some condensation. After the determination of the amount of condensation a recalculation of V_3 would be necessary as some of the water has been removed from the mixture leaving the air saturated.

The moisture having a specific weight of 0.00073 would be saturated at 56° F. so that this moisture is superheated 9° F.

Approximate value of T_4 :

$$T_4 = T_3 \left(\frac{p_1}{p_2} \right)^{\frac{k-1}{k}} = 525 \times \left(\frac{1}{4} \right)^{1.4} = 354^\circ \text{ abs.} = -106^\circ \text{ F.}$$

$$C = 0.0002[(65 - 32)^{1/2} + 1071.7 + 144] = 0.2462$$

$$V'_3 = 0.082 \left[\frac{53.35 \times 525}{14.7 \times 4 \times 144} \right] = 0.2715$$

$$\left(0.082 \times 0.24 + 0.0002 \times 0.5 + \frac{0.2462}{65 + 106} \right) \frac{1}{53.34} \log_e \frac{T_3}{T_4} = \frac{0.082}{778} \log_e 4$$

$$\frac{0.02119}{53.34} \log_e \frac{T_3}{T_4} = \frac{0.082}{778} \log_e 4$$

$$\log \frac{T_3}{T_4} = 0.161 = \log 1.45$$

$$T_4 = \frac{525}{1.45} = 361^\circ \text{ abs.} = -99^\circ \text{ F.}$$

$$W_e = 778[0.02119][65 - (-99)] = 2695 \text{ ft.-lbs.}$$

$$W_c = \frac{1.4}{0.4} \times 14.7 \times 144 \times 1 \left[1 - \left(\frac{1}{4} \right)^{1.4} \right] = -3600 \text{ ft.-lbs.}$$

Net work without friction = 3600 - 2695 = 905 ft.-lbs.

Net work with friction = 3600 × 1.10 - 2695 × 0.9 = 1534 ft.-lbs.

$$Q_c = [0.082 \times 0.24 + 0.0002 \times 0.39][260^\circ - 65^\circ] = 3.86$$

$$Q_r = [0.082 \times 0.24][25 - (-99)] = 2.44$$

$$\text{Coefficient of performance without friction} = \frac{2.44}{\frac{905}{778}} = 2.10.$$

$$\text{Coefficient of performance with friction} = \frac{2.44}{\frac{1530}{778}} = 1.24.$$

$$\text{B.t.u. of refrigeration per ft.-lb. of work} = \frac{2.44}{1530} = 0.00159.$$

$$\text{B.t.u. per h.p.-hr.} = 0.00159 \times 33,000 \times 60 = 3120.$$

$$\text{Tons of ice melting capacity per 24 hrs. per h.p.} = \frac{3120 \times 24}{2000 \times 144} = 0.26.$$

Assuming 3 lbs. of coal per horse-power hour:

$$\text{Tons of ice melting capacity per 24 hrs. per lb. coal} = \frac{0.26}{3 \times 24} = 0.00361.$$

$$\text{Tons of ice melting capacity per cu. ft.} = \frac{2.44}{144 \times 2000} = 0.0000085.$$

$$\text{Gallons of cooling water per cu. ft. of piston displacement for a } 15^\circ \text{ rise in water temperature} = \frac{3.86}{15 \times 8.35} = 0.0305.$$

$$\text{Gallons per ton of ice melting capacity} = \frac{0.0305}{0.0000085} = 3590.$$

$$\text{Relative volume of expansion cylinder and compression cylinder} = \frac{T_4}{T_1} = \frac{364}{485} = 0.745. \quad (\text{Air removed by freezing in short time})$$

If this is worked out without moisture the following results are found:

$$M_a = \frac{14.7 \times 144 \times 1}{53.34 \times 485} = 0.082$$

$$T_1 = 485^\circ \text{ abs.} = 25^\circ \text{ F.}$$

$$T_2 = 485(4)^{0.4} = 720^\circ \text{ abs.} = 260^\circ \text{ F.}$$

$$T_3 = 65 + 460 = 525^\circ \text{ abs.}$$

$$T_4 = 525 \times \frac{485}{720} = 354^\circ \text{ abs.} = -106^\circ \text{ F.}$$

$$W_c = 3600$$

$$W_e = 3600 \times \frac{354}{485} = 2630$$

$$\text{Net work} = 1.10 \times 3600 - 0.9 \times 2630 = 1593 \text{ ft.-lbs.}$$

$$Q_c = 0.082 \times 0.24[260^\circ - 65^\circ] = 3.84$$

$$Q_r = 0.082 \times 0.24[25^\circ - (-106^\circ)] = 2.58$$

$$\text{Coefficient of performance} = \frac{2.58}{\frac{1593}{778}} = 1.26.$$

$$\text{B.t.u. per ft.-lb. of work} = \frac{2.58}{1593} = 0.00162.$$

$$\text{B.t.u. of refrigeration per h.p.-hr.} = 0.00162 \times 33,000 \times 60 = 3180.$$

$$\text{Tons of ice melting capacity per 24 hrs. per h.p.} = \frac{3180 \times 24}{2000 \times 144} = 0.264.$$

Assume 3 lbs. of coal per h.p.-hr.:

$$\text{Tons of ice melting capacity per 24 hrs. per lb. coal} = \frac{0.264}{3 \times 24} = 0.00368.$$

$$\text{Tons of ice melting capacity per cu. ft. of compression cylinder without clearance} = \frac{2.58}{144 \times 2000} = 0.000009.$$

$$\text{Gallons of cooling water per cu. ft. of piston displacement for a } 15^\circ \text{ rise in water temperature} = \frac{3.84}{15 \times 8.35} = 0.0306.$$

$$\text{Gallons per ton of ice melting capacity} = \frac{0.0306}{0.000009} = 3400.$$

$$\text{Relative volume of expansion cylinder and compression cylinder} = \frac{T_4}{T_1} = \frac{354}{485} = 0.732.$$

The actual volumes displaced by the pistons will be increased by clearance. The volume computed divided by the clearance factor will give the actual volume.

The use of air, although cheap, has the great objection that the volume of the compressor and expander are large for a given amount of refrigeration. To reduce the size of the machines, ammonia or other volatile liquids are used as the media. The substances used are NH_3 , SO_2 and CO_2 and certain mixtures such as Pictet fluid composed of 97 per cent. of SO_2 and 3 per cent. of CO_2 . The advantages and disadvantages of the various liquids will be discussed later.

VAPOR REFRIGERATING MACHINES

In machines using these **volatile liquids** the **heat is abstracted** not by an increase in temperature of the refrigerating medium but **by the evaporation of a liquid**. The underlying principle

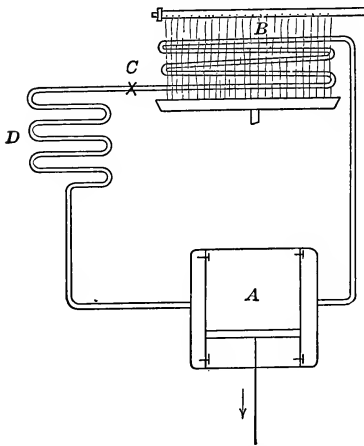

FIG. 194.—Arrangement of the vapor refrigerating machinery.

of these machines is to bring the vapor to such a pressure that the temperature of liquefaction is slightly above the temperature of a water supply, and by means of this water the ab-

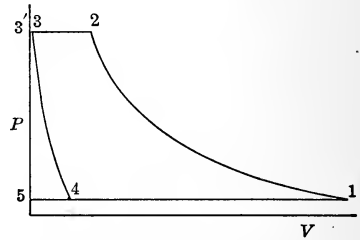

FIG. 195.— P - V diagram of the vapor refrigerating machine. Compressor and expansive cylinder.

straction of heat is possible. This abstraction condenses the vapor and after the pressure on the liquid is so reduced that the temperature of vaporization is very low, the liquid may evaporate by the heat abstracted from a space at a low temperature. The temperature of cooling water fixes the upper pressure and the temperature of the refrigerated space fixes the necessary low pressure. It is merely a matter of pressure regulation to fix the temperature limits.

The apparatus used to accomplish this result is shown in Fig. 194. Fig. 195 represents the PV diagram for the cycle.

In the **compressor A** the ammonia or other vapor is compressed adiabatically from 1 to 2. This will superheat the ammonia vapor if dry vapor is taken into the cylinder, while if there is considerable liquid mixed with the vapor the compression will reduce the amount of this liquid. The first is called **dry compression** and the second **wet compression**. These two lines are shown in Fig. 196 which is the $T-S$ diagram of the cycle. The line 1-2 in either case is an adiabetic. It is seen more clearly from Fig. 196 that the temperature is increased as the compression takes place so that when the compressed vapor is delivered from the compressor into the **condensing coil or condenser, B**, this water may abstract heat and condense the vapor. This occurs from 2 to 3 in Fig. 196 while in Fig. 195 the line 2-3' represents the discharge from the compressor and 3'-3 represents the volume of the liquid. At times the liquid is cooled to a lower temperature by passing it through a coil cooled by the coldest water. This is shown in Fig. 196 by 3-3''.

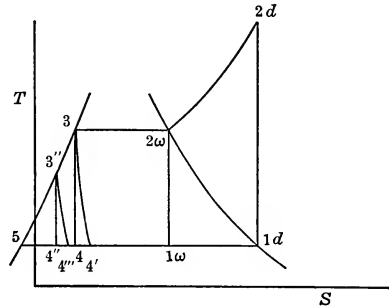

FIG. 196 $T-S$ diagram of the cycle of the vapor-refrigerating machine.

If now the liquid be allowed to expand from 3 to 4 or 3'' to 4'' on an adiabetic in an **expansion cylinder** the work 5345 would be obtained. This amount would be very slight and the return would not pay for the complication. Hence the pressure is reduced from p_2 to p_1 by means of the **expansion valve C**. This **throttling action** results in a value of the **heat content** below the valve equal to that above the valve.

$$i_3 = i_4' \quad (54)$$

or
$$i_{3''} = i_{4''}$$

This, of course, reduces the refrigerating effect as

$$i_4' > i_4$$

and
$$i_{4''} > i_{4'}$$

but the elimination of the expansion cylinder has made the apparatus simpler. The exact loss due to this may be found later.

After the pressure is reduced the temperature of vaporization is so low that heat will be abstracted from the surrounding substances, even though they be at a low temperature, and the liquid vaporizes. This is accomplished in the **refrigerating coil D**. Here the evaporation of the liquid returns either dry vapor or wet vapor to the compressor *A* and the cycle is repeated.

The **expressions for the heat on the various lines** are now computed.

Heat on 1-2 = 0

$$Q_c = \text{heat on 2-3 at constant pressure} = i_2 - q'_3 \quad (55)$$

$$Q_c = \text{heat on 2-3'' at constant pressure} = i_2 - q'_{3''} \quad (56)$$

Heat on 3-4, 3-4', 3''-4'' or 3'''-4''' = 0

$$Q_r = \text{heat on 4-1} = i_1 - i_4 \text{ or } i_1 - i_{4'} \quad (57)$$

But $i_3 = i_{4'}$

$$\therefore Q_r = i_1 - i_3 \text{ or } i_1 - i_{3''} \quad (58)$$

Now i_1 is the expression for the heat content at either 1*d* or 1*w* and i_2 is the heat content at 2*w* or 2*d*. It and the other quantities may be found in ammonia tables.

$$i = q' + xr$$

or
$$i = q' + r + \int_{T_{sat.}}^{T_{sup.}} c_p dt$$

The expression for the heat added on a constant pressure line from *a* to *b* is

$$i_b - i_a \quad (59)$$

as is given under Q_r and Q_c .

The equation of the line 1-2 is the adiabatic

$$s = \text{constant}$$

$$s = s'_1 + \frac{x_1 r_1}{T_1} \text{ if wet}$$

or $pv^k = \text{constant}$ if dry.

$k = 1.33$ for superheated ammonia. Of course if tables for superheated vapor are known, the formula

$$s_1 = s_2$$

may be used for the superheated region also. This is really the better equation even in the superheated region.

The work required is the algebraic sum of the heats

$$\begin{aligned}
 AW &= Q_r - Q_c = -[Q_c - Q_r] \\
 -AW &= [i_2 - i_3'] - [i_1 - i_3'] \\
 &= i_2 - i_1
 \end{aligned}
 \tag{60}$$

$$\text{With friction } -AW = (1 + f)(i_2 - i_1) \tag{61}$$

The amounts above are all for 1 lb. of ammonia and to find the amount of liquid, per minute, hour or day, the amount of refrigeration in that time is divided by the refrigeration per pound. Thus for T tons of refrigeration per day the weight of volatile liquid per minute is

$$M = \frac{200T}{i_1 - i_3'} \tag{62}$$

The horse-power required is

$$\text{h.p.} = \frac{M(1 + f)(i_2 - i_1)}{42.42} \tag{63}$$

The weight of cooling water per minute is

$$M_w = \frac{M(i_2 - i_3')}{q'_o - q'_i} \tag{64}$$

where q'_o = heat of liquid for condensing water at outlet
 q'_i = heat of liquid for condensing water at inlet.

The displacement per minute of the compressor is given by

$$D_v = \frac{Mv''}{\text{clearance factor}} \text{ or } \frac{Mv}{\text{clearance factor}} \tag{65}$$

The displacement of the cylinder is found by computing the clearance factor as in the case of air compressors. The lines of expansion and compression are of the same form. This is shown by Fig. 197, the actual form of the card. If V for the ammonia on the lower line is known

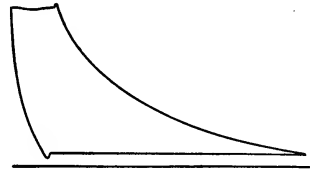

FIG. 197.—Actual card from a compressor.

$$D = \frac{V}{1 + l - l \left(\frac{p_2}{p_1} \right)^{\frac{1}{n}}} \tag{66}$$

The refrigerative effect is given by

$$N_r = \frac{i_1 - i_3'}{(1 + f)(i_2 - i_1)} \tag{67}$$

In many cases where rooms have to be cooled, the ammonia

or air is not sent through coils in the room but heat is removed from the rooms by circulating cold brine through pipes. The brine is cooled by the air or ammonia which passes through a coil in a tank through which the brine is pumped. The brine is usually a solution of calcium chloride or sodium chloride. The advantage of the brine system over the direct expansion system is the fact that the break of a pipe would not discharge the ammonia into the room and spoil the contents and also the fact that the compressor may be shut down for some time and the cold brine stored in the brine tank may be used to keep the room cool.

These formulæ may be used for any volatile liquid. Even water has been used although exceeding low pressures must be used to obtain temperatures below 32° F. A problem will be computed using NH₃, SO₂ and CO₂ for the media assuming water at 50° to 65° F. and a refrigerating room held at 25° F.

In this problem it will be assumed that 15° is the necessary difference of temperature for heat transfer and also that wet and dry compression will be tried for the ammonia. For dry compression $x_1 = 1$ while for wet compression $x_2 = 1$. It will be assumed that "after cooling" reduces T_3 to 50° + 15° = 65° F. In all cases the volume drawn into the compressor with 1 per cent. clearance will be assumed to be 1 cu. ft.

In these problems

$$T_4 = T_1 = 25^\circ - 15^\circ + 460^\circ = 470^\circ \text{ abs.}$$

$$T_{2d} = 65^\circ + 15^\circ + 460^\circ = 540^\circ \text{ abs.}$$

$$T_{3'} = 50^\circ + 15^\circ + 460^\circ = 525^\circ \text{ abs.}$$

AMMONIA:

Case I.—Wet compression.

$$p_1 = 38.02 \text{ lbs.}$$

$$p_2 = 153.90 \text{ lbs.}$$

$$x_2 = 1$$

$$x_1 = \left(s'_2 + \frac{x_2 r_2}{T_2} - s'_1 \right) \div \frac{r_1}{T_1}$$

$$= \frac{0.1025 + 0.9328 + 0.0483}{1.2017} = 0.902$$

$$i_2 = 557$$

$$i_1 = -23.2 + 0.902 \times 564.4 = 485.0$$

$$i_{3'} = 36.5$$

$$M = \frac{1}{6.64} = 0.151$$

$$Q_c = 0.151[564.4 - 36.5] = 78.6 \text{ B.t.u.}$$

$$Q_r = 0.151[485 - 36.5] = 67.8 \text{ B.t.u.}$$

$$AW = 78.6 - 67.8 = 10.8 \text{ B.t.u.}$$

$$\text{or} \quad = 0.151[564.4 - 485] = 10.8 \text{ B.t.u.}$$

$$AW \text{ with friction} = 10.8 \times 1.20 = 12.96$$

$$\text{Refrigerating effect without friction} = \frac{67.8}{10.8} = 6.23$$

$$\text{Refrigerating effect with friction} = \frac{67.8}{12.96} = 5.22$$

$$\text{B.t.u. per ft.-lb. of work} = \frac{67.8}{12.96 \times 778} = 0.00673$$

$$\text{B.t.u. of refrigeration per h.p.-hr.} = 0.00673 \times 33,000 \times 60 = 13,200$$

$$\text{Tons of refrigeration per h.p.} = \frac{13200 \times 24}{2000 \times 144} = 1.10$$

(Assume 3 lbs. of coal per h.p.-hr.)

$$\text{Tons of refrigeration per lb. coal} = \frac{1.10}{3 \times 24} = 0.0153$$

$$\frac{\text{Tons of refrigeration per cu. ft. of compressor volume taken in} = \frac{67.8}{144 \times 2000} = 0.000235$$

$$\text{Gallons of cooling water per cu. ft. of compressor volume taken in for } 15^\circ \text{ rise in cooling water} = \frac{78.6}{15 \times 8.35} = 0.628$$

$$\text{Gallons per ton of refrigeration} = \frac{0.628}{0.000235} = 2670$$

Case II.—Dry compression.

$$p_1 = 38.02 \text{ lbs.}$$

$$p_2 = 153.90 \text{ lbs.}$$

$$s_2 = s_1 = 1.1534.$$

This is s_2 for 110° F. superheat.

(This may be checked by

$$T_2 = T_1 \left(\frac{p_2}{p_1} \right)^{0.25} = 470 \left(\frac{153.9}{38.02} \right)^{0.25} = 664^\circ \text{ abs.}$$

$$\text{Deg. superheat} = 664 - 540 = 124^\circ \text{ F.}$$

$$i_2 = 628.4 \text{ B.t.u.}$$

$$M = \frac{1}{7.34} = 0.136$$

$$i_1 = 541.2$$

$$i_3' = 36.5$$

$$Q_c = 0.136 [628.4 - 36.5] = 80.5$$

$$Q_r = 0.136 [541.2 - 36.5] = 68.6$$

$$AW = 80.5 - 68.6 = 11.9$$

$$AW \text{ with friction} = 11.9 \times 1.20 = 14.3$$

$$\text{Refrigerating effect without friction} = \frac{68.6}{11.9} = 5.76$$

$$\text{Refrigerating effect with friction} = \frac{68.6}{14.3} = 4.80$$

$$\text{B.t.u. per ft.-lb. of work} = \frac{68.6}{14.3 \times 778} = 0.00617$$

$$\text{B.t.u. of refrigeration per h.p.-hr.} = 0.00617 \times 33,000 \times 60 = 12,200$$

$$\text{Tons of refrigeration per h.p.} = \frac{12200 \times 24}{2000 \times 144} = 1.02$$

$$\frac{\text{Tons of refrigeration per lb. coal (assume 3 lbs. coal per h.p.-hr.)} = \frac{1.02}{3 \times 24} = 0.0142$$

$$\frac{\text{Tons of refrigeration per cu. ft. of compressor volume taken in} = 68.6}{144 \times 2000} = 0.000238$$

$$\text{Gallons of cooling water per cu. ft. of compressor volume taken in for } 15^\circ \text{ rise in cooling water} = \frac{80.5}{15 \times 8.35} = 0.644$$

$$\text{Gallons per ton of refrigeration} = \frac{0.644}{0.000238} = 2700$$

Carbon Dioxide.—(Wet compression).

$$T_4 = T_1 = 470^\circ \text{ abs.} = 10^\circ \text{ F.}$$

$$T_{2d} = 540^\circ \text{ abs.} = 80^\circ \text{ F.}$$

$$T_3 = 525^\circ \text{ abs.} = 65^\circ \text{ F.}$$

$$p_1 = 362.8 \text{ lbs.}$$

$$p_2 = 936 \text{ lbs.}$$

$$i_2 = 80$$

$$s_2 = 0.1511$$

$$s_1 = 0.1511 = -0.0226 + x_1 0.2164$$

$$x_1 = 0.80$$

$$i_1 = -11.23 + 0.80 \times 110.12 = 76.86$$

$$i_3 = 21.8$$

$$v_1 = 0.247 \times 0.80 = 0.198$$

$$M = 5.05$$

$$Q_c = 5.05[80 - 21.8] = 294$$

$$Q_r = 5.05[76.9 - 21.8] = 278.4$$

$$AW = 5.05[80 - 76.9] = 15.6$$

$$AW \text{ with friction} = 15.6 \times 1.50 = 23.4$$

(Friction has been increased due to the packing made necessary by the excessive pressure.)

$$\text{Refrigerating effect without friction} = \frac{278.4}{15.6} = 17.8$$

$$\text{Refrigerating effect with friction} = \frac{278.4}{23.4} = 11.9$$

$$\text{B.t.u. per ft.-lb. work} = \frac{278.4}{23.4 \times 778} = 0.0131$$

$$\text{B.t.u. of refrigeration per h.p.-hr.} = 0.0131 \times 33,000 \times 60 = 26,000$$

$$\text{Tons of refrigeration per h.p.} = \frac{26000 \times 24}{2000 \times 144} = 2.17$$

(Assume 3 lbs. coal per h.p.-hr.)

$$\text{Tons of refrigeration per lb. coal} = \frac{2.17}{3 \times 24} = 0.0301$$

$$\frac{\text{Tons of refrigeration per cu. ft. of compressor volume taken in} = 278.4}{144 \times 2000} = 0.000965$$

$$\text{Gallons of cooling water per cu. ft. of compressor volume taken in for } 15^\circ \text{ rise in cooling water} = \frac{294}{15 \times 8.35} = 2.35$$

$$\text{Gallons per ton of refrigeration} = \frac{2.35}{0.000965} = 2430$$

Sulphur Dioxide.—(Wet compression).

$$\begin{aligned}
 T_4 = T_1 &= 470^\circ \text{ abs.} = 10^\circ \text{ F.} \\
 T_{2d} &= 540^\circ \text{ abs.} = 80^\circ \text{ F.} \\
 T_3 &= 525^\circ \text{ abs.} = 65^\circ \text{ F.} \\
 p_1 &= 13.5 \text{ lbs.} \\
 p_2 &= 59.65 \text{ lbs.} \\
 i_2 &= 162.1 \\
 s_2 &= 0.302 \\
 s_1 &= 0.302 = -0.1746 + x_1 0.3625 \\
 x_1 &= 0.88 \\
 i_1 &= -6.89 + 0.88 \times 169.78 = 142.6 \\
 i_3 &= 10.96 \\
 v_1 &= 0.88 \times 5.96 = 5.25 \\
 M &= \frac{1}{5.25} = 0.19 \\
 Q_c &= 0.19[162.1 - 10.96] = 28.8 \\
 Q_r &= 0.19[142.6 - 10.96] = 25.0 \\
 AW &= 0.19[162.1 - 142.6] = 3.71
 \end{aligned}$$

$$AW \text{ with friction} = 3.71 \times 1.20 = 4.46$$

$$\text{Refrigerating effect without friction} = \frac{25}{3.71} = 6.75$$

$$\text{Refrigerating effect with friction} = \frac{25}{4.46} = 5.61$$

$$\text{B.t.u. per ft.-lb. work} = \frac{25}{4.46 \times 778} = 0.00725$$

$$\text{B.t.u. per h.p.-hr.} = 0.00725 \times 33,000 \times 60 = 14,350$$

$$\text{Tons of refrigeration per h.p.} = \frac{14350 \times 24}{2000 \times 144} = 1.195$$

(Assume 3 lbs. coal per h.p.-hr.)

$$\text{Tons of refrigeration per lb. coal} = \frac{1.195}{3 \times 24} = 0.0167$$

$$\text{Tons of refrigeration per cu. ft. of compressor volume taken in} = \frac{25}{144 \times 2000} = 0.000087$$

$$\text{Gallons of cooling water per cu. ft. of compressor volume taken in for a } 15^\circ \text{ rise in cooling water} = \frac{28.8}{15 \times 8.35} = 0.23$$

$$\text{Gallons per ton of refrigeration} = \frac{0.23}{0.000087} = 2640$$

ABSORPTION APPARATUS

To eliminate as far as possible the moving parts of a refrigerating apparatus and to utilize waste heat from other machines the absorption type of refrigerating machine has been developed. In this the high pressure is produced by boiling a solution of NH_3 in water and driving off the NH_3 by a steam coil at such a rate that the pressure is sufficient to produce a temperature of condensa-

tion above the temperature of the supply water. The low pressure is maintained by absorbing the vapor in water at a rate to produce this pressure.

The apparatus, Fig. 199, consists of a **generator** *A* in which a **steam coil** *B* supplies enough heat to warm the liquor of aqua ammonia to such a temperature that its capacity for ammonia is reduced and the ammonia is driven off. This gas is superheated as it leaves the generator and to use some of the heat above saturation (as the gas must finally be condensed) it is passed over a series of baffle-plates over which the fresh strong liquor passes on its way to the generator *B*. The part of the apparatus *C* is called the **analyzer**. The function of this is to

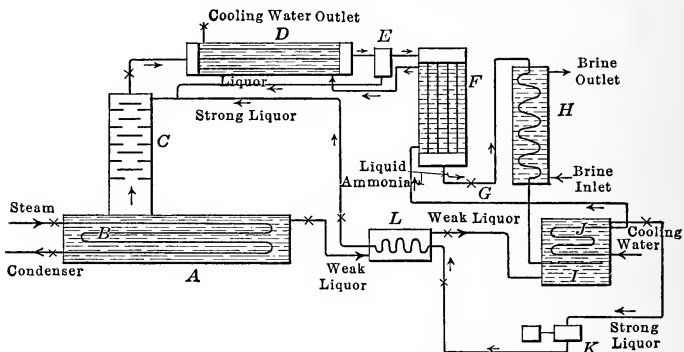

Fig. 198.—Absorption machine.

reduce the superheat in the discharge gases. As the gas or vapor of ammonia contains some water vapor which would interfere with the action of the vapor in the expansion valve, and as it would use some of the refrigerating capacity when it absorbs ammonia after its condensation, a **rectifier** *D* is used to reduce the water content. This rectifier cools the vapors still further. The heat is absorbed by cold water or by the strong liquor which is pumped from the absorber through tubes in the rectifier on its way to the generator. This substance is at a lower temperature than the vapors, and although low enough to condense most of the water it is not low enough to condense the ammonia. The condensed water is caught in a **separator** *E* and as it absorbs ammonia, the aqua liquor thus formed is sent back to the generator. From the rectifier the dry vapor is sent into the **condenser** *F* where the ammonia vapor is condensed by a cold water supply. The liquid is now passed through the **expansion valve**

G and enters the **expansion coil** of the **brine cooler** *H* in which the liquid is evaporated by the abstraction of heat from the surrounding brine. If the direct-expansion system is used this heat is drawn from the room. The vapor is drawn into the **absorber** *I* by the **weak liquor** which has been allowed to flow from the generator. The great capacity of this weak liquor for ammonia produces a reduction in pressure of the vapor. This absorption of ammonia generates heat and a coil *J* through which cool water is circulated is placed in the absorber to keep the temperature at a low point. This low temperature is necessary to keep liquor at a point of great capacity for ammonia. The absorbing power of water decreases as the temperature is increased. The strong liquor is pumped from the absorber into the generator at higher pressure by the **pump** *K*. To save some of the heat it is passed through the **interchanger** *L* in which it takes heat from the hot weak liquor leaving the bottom of the generator. The weak liquor flows to the absorber *I* in which the pressure is less than that in the generator. This strong liquor is sometimes first passed through the rectifier pipes as it is cool enough to condense the water vapor, and from this coil it passes to the interchanger or exchanger *L* and then the strong liquor is discharged into the analyzer in which it is still further warmed by the superheated vapors. The arrangement in the figure, however, is such that water is used to cool the analyzer. The strong liquor finally reaches the generator and the boiling drives off the ammonia.

The **principle of the absorption machine** is the same as that of the compression machine. The vapor is put under such a pressure that its temperature of vaporization is above that of a water supply and this water may remove heat and condense the ammonia; after this it is placed under such a pressure that heat may be abstracted from a region of low temperature. The pressure is produced by the steam coil in place of the compressor and the low pressure is maintained by absorption in place of the suction of the compressor.

PROPERTIES OF AQUA AMMONIA

The action of ammonia and water (known as aqua ammonia) will now be studied to form a basis for the analysis of the action of this machine.

The **amount of ammonia** or other vapor **absorbed** by a pound

of water depends on the pressure and temperature of the water. Thus, according to the table prepared by Lucke, water will only absorb 3.1 per cent. of its weight of NH_3 at 191°F. and atmospheric pressure, while at 50 lbs. gauge pressure this temperature for the same concentration could be raised to 280°F. 191.5°F. is the temperature limit at 50 lbs. pressure for 28 per cent. of absorption.

The relation between the **pressure, per cent. of ammonia** in a solution **and the temperature** at which this solution will give off ammonia or rather boil has been determined experimentally by Mollier and although plotted in curves these values are represented by MacIntire by the equation

$$\frac{T_{sat.}}{T_{sol.}} = 0.00466x + 0.656 \quad (67)$$

$T_{sat.}$ = temperature of saturation of ammonia for a given pressure.

$T_{sol.}$ = temperature at which the solution boils.

x = per cent. of NH_3 in solution = per cent. of concentration.

= lbs. of NH_3 in 1 lb. of solution.

This formula holds to 50 per cent. concentration. Above that concentration the formula does not give correct results but this is not important as such high concentrations are rarely used.

The vapor concentration of the liquid being known with the temperature of boiling ($T_{sol.}$), the temperature ($T_{sat.}$) corresponding to the boiling pressure, $p_{sat.}$, of liquid ammonia is found. This gives the total pressure exerted by the ammonia and water vapors driven off from the liquor. The **partial pressures** exerted by the two constituents are not well known at present. These partial pressures are proportional to the number of molecules present or to the partial volumes of each constituent. To know how these molecules come off from the solution is a difficult problem. Lucke quotes values of partial pressures from Perman. These are limited to 140°F. and to concentrations from 2.5 to 22.5 per cent. by weight of ammonia. The values indicate the manner in which the ammonia vapor pressure varies with the water vapor.

Spangler suggests that the water vapor pressure is equal to that for steam at the temperature given multiplied by the ratio of number of the molecules of water vapor to the total number

of molecules present. He assumes that the concentration of the vapor is the same as the concentration of the liquid. Thus if x is the per cent. solution which is ammonia or the amount of ammonia in 100 lbs. of liquor the ratio of the number of ammonia molecules and water molecules is

$$\frac{x}{17} \text{ to } \frac{100 - x}{18}$$

Hence if p is the steam pressure for the temperature considered:

$$p \frac{\frac{100 - x}{18}}{\frac{100 - x}{18} + \frac{x}{17}} = p \frac{1700 - 17x}{1700 + x}$$

= partial pressure of moisture. (68)

This checks with the results of Perman, as given by Lucke, with a close degree of approximation.

If 1 lb. of ammonia be added to a large quantity of water it is found that 893 B.t.u. of heat will be liberated. This is called the **heat of complete absorption**. If the ammonia is not mixed with a large quantity of water the absorption will be **partial**. If strong ammonia liquor is added to water it is found that heat is developed by the solution of this in water; the strong solution acting as ammonia. This latter heat is called the heat of **complete dilution** and the difference between the **heat of complete absorption** and that of **complete dilution** is known as the **heat of partial absorption**. Complete dilution occurs when the ammonia is diluted with 200 times its weight of water.

It has been found by Berthelot that the amount of heat developed when a liquor of aqua ammonia is diluted so that the water content is 200 times the weight of the ammonia, if multiplied by the weight of water per pound of ammonia in the original solution gives a constant or practically constant product, 142.5. The heat of complete dilution becomes

$$Q = \frac{142.5}{\frac{100 - x}{x}} = \frac{142.5x}{100 - x} \quad (69)$$

x = per cent. weight of NH_3 in 1 lb. of mixture.

Some later results by Thomsen pertaining to much greater dilutions than those of the useable experiments of Berthelot's

indicate that 142.5 may be used, the constant varying from 154 for 19.27 parts of water, to 148 for 29.36 parts and 113 for 56.33 parts.

If now 893 B.t.u. is the heat of complete absorption and $\frac{142.5x}{100-x}$ is the heat of complete dilution

$$893 - \frac{142.5x}{100-x} = \text{heat of partial absorption.} \quad (70)$$

The **heat of partial absorption** is the heat liberated when 1 lb. of ammonia in solution is added to enough water to bring it to a concentration of x .

If $\frac{x}{100}$ lbs. of ammonia are absorbed by $\frac{100-x}{100}$ lbs. of water the heat developed will be

$$Q = 893 \frac{x}{100} - \frac{142.5x^2}{100(100-x)} \quad (71)$$

If now ammonia were absorbed to change the concentration from x to x' , the amount of ammonia then present in the water contained in the original pound of solution of strength x would be

$$\frac{x'}{100} \times \frac{100-x}{100-x'} \quad (72)$$

This may be seen from the fact that the amount of water in 1 lb. of a solution of strength x is $\frac{100-x}{100}$ and the amount of ammonia per pound of water in the second condition is

$$\frac{x'}{100-x'}$$

Hence the amount of ammonia in $\frac{100-x}{100}$ lbs. of water is

$$\frac{100-x}{100} \times \frac{x'}{100-x'} = \frac{x'}{100} \times \frac{100-x}{100-x'}$$

The heat generated by the addition of this amount of ammonia to bring the solution to strength x' is

$$\frac{x'}{100} \times \frac{100-x}{100-x'} \left[893 - \frac{142.5x'}{100-x'} \right] \quad (73)$$

The heat developed by the addition of ammonia to change the strength of the solution from x to x' is therefore

$$Q = \frac{x'}{100} \times \frac{100-x}{100-x'} \left[893 - \frac{142.5x'}{100-x'} \right] - \frac{x}{100} \left[893 - \frac{142.5x}{100-x} \right] \quad (74)$$

The weight of ammonia added is

$$\left[\frac{x'}{100} \times \frac{100 - x}{100 - x'} \right] - \frac{x}{100} = \text{wt.}$$

If the heat is divided by the weight the result will be the heat per pound or

$$q = 893 - 142.5 \left[\frac{x'}{100 - x'} + \frac{x}{100 - x} \right] \quad (75)$$

This is the amount of heat liberated when 1 lb. of ammonia vapor is absorbed by a liquor of concentration x to change the concentration to x' .

The above expression is true for the absorption of ammonia but when 1 lb. of ammonia is driven from a solution to change the concentration x' to concentration x not only is the heat q necessary but in addition to this, it is necessary to evaporate the water vapor present and to superheat the vapors. The amounts of these quantities will be found in a problem later.

The **density of the liquor** of aqua ammonia varies with the amount of ammonia absorbed decreasing with the concentration. The specific gravity is given for various concentrations x by

$$\text{sp. gr.} = 1 - \frac{4.3}{1000} \left[x - \frac{x^2}{100} + \frac{x^3}{10000} \right] \quad (76)$$

The strong solution would be lighter and would stay at the top were it not for diffusion.

The **specific heat of aqua ammonia** will be assumed to be unity.

When a strong liquor of strength x' is changed to strength x by giving off 1 lb. of ammonia the number of pounds of strong solution, y , required is given by

$$\begin{aligned} y \frac{x'}{100} - (y - 1) \frac{x}{100} &= 1 \\ y &= \frac{1 - \frac{x}{100}}{\frac{x'}{100} - \frac{x}{100}} = \frac{100 - x}{x' - x} \end{aligned} \quad (77)$$

The weight of weak solution is $(y - 1)$.

The above discussion gives the necessary properties of aqua ammonia and to apply them as well as to compute the heat transfers in the various parts of the apparatus a problem will be solved.

PROBLEM

Find the amount of refrigeration per pound of ammonia driven off per minute from 25 per cent. solution in the generator if the room temperature is to be held at 25° F. and the cooling water varies from 50° to 65° F. How much steam at 20 lbs. gauge pressure and $x = 0.9$ would be required per minute per ton of capacity? Find the heat transfer of the various parts of the apparatus together with the amount of water used and a heat balance.

Temperatures and Pressures.

Temperature of ammonia in condenser with a 15° difference from the hottest water is $65^\circ + 15^\circ = 80^\circ$ F.

Temperature in expansion coil with 15° difference of temperature is $25^\circ - 15^\circ = 10^\circ$ F.

Temperature of steam in generator (at 34.7 lbs. abs.) = 259° F.

Pressure in condenser

$$\text{Ammonia pressure (for } 80^\circ \text{ F.)} = 153.9 \text{ lbs.}$$

$$\text{Steam pressure (for } 80^\circ \text{ F.)} = \underline{0.5 \text{ lbs.}}$$

$$\text{Total pressure} = 154.4 \text{ lbs.}$$

Pressure in expansion coil (10° F.) = 38.02 lbs.

Pressure in absorber [38.02 - 0.5 (assumed)] = 37.52 lbs.

Temperature of saturation of ammonia = 9.5° F.

Pressure in rectifier [154.4 + 0.5] = 154.9 lbs.

Temperature limit of rectifier (154.9 lbs.) = 80.4° F.

Pressure in analyzer [154.9 + 0.5] = 155.4 lbs.

Pressure in generator [155.4 + 0.5] = 155.9 lbs.

Temperature limits in various parts:

Generator.—For 155.9 lbs. pressure the temperature at which a 25 per cent. solution will boil is

$$\frac{80.8 + 460}{T_{sol.}} = 0.00466 \times 25 + 0.656$$

$$T_{sol.} = \frac{540.8}{0.773} = 700^\circ \text{ abs.} = 240^\circ \text{ F.}$$

This is the lowest temperature possible to drive off the ammonia with 25 per cent. concentration. As the evaporation is carried on the concentration becomes less. To boil the liquor to a smaller concentration requires a temperature higher than 240° F. The heat required to liberate the ammonia from the

strong liquor reduces the temperature of the weak liquor and makes the temperature of the vapors leaving the generator that required by the formula for the strong liquor. This will be the assumption used in this work.

The limiting concentration at this point when the liquid has time to be brought to within 5° of the temperature of steam, or $259 - 5 = 254^\circ$ F., is

$$\frac{540.8}{254 + 460} = 0.00466x + 0.656$$

$$x = \frac{102}{4.66} = 21.9 \text{ per cent.}$$

This gives a very small change in concentration. Suppose that the gauge pressure is raised to 30 lbs. This gives a temperature of 274° F.

$$\frac{540.8}{274 + 460} = 0.00466x + 0.656$$

$$x = 17.50 \text{ per cent.}$$

This will be used.

Thus the pressure in the condenser fixes the pressure in the generator and this with the concentration fixes the temperature or pressure for the steam used to boil solutions.

The temperature limit of the absorber is given by

$$\frac{9.5 + 460}{T_{sol.}} = 0.00466 \times 25 + 0.656$$

$$T_{sol.} = \frac{469.5}{0.773} = 607^\circ \text{ abs.} = 147^\circ \text{ F.}$$

Suppose this is kept at 145° F.

For a 15° difference in temperature in the coils of the absorber the water should be kept at 130° F. Of course the water from the condenser could be used here as its temperature is not above 65° F.

Limiting conditions leaving rectifier are given by the temperature of condensation of the ammonia. This is 80.4° F. so the temperature at this point may be taken at 90° F. The possible concentration at 90° F. and pressure 154.9 lbs. is

$$\frac{80.4 + 460}{90 + 460} = 0.00466x + 0.656$$

$$x = 70 \text{ per cent.}$$

Having these limiting concentrations, the amount of moisture

at the various points may be found except at the discharge from the analyzer because at that point the temperature is not known as it is due to the mixture of the strong liquor and the liquor from the rectifier. To find this, the amount of strong liquor to give 1 lb. of ammonia when changed from 25 per cent. concentration to 17.5 per cent. concentration is computed. The formula

$$y = \frac{100 - x}{x' - x}$$

is true for absorption and gives 11.00 lbs. for y for the conditions above.

$$y = \frac{100 - 17.5}{25 - 17.5} = 11.00$$

When ammonia is driven off some steam is driven with the ammonia and for this reason the concentration of the remaining liquor is made greater. To find the value of y the conditions leaving the generator must be known.

Total pressure in generator.....	155.9 lbs.
Temperature in generator.....	240° F.
Concentration.....	25 per cent.
Partial pressure of steam (for 240° F.) = $24.97 \left(\frac{1700 - 17 \times 25}{1700 + 25} \right)$	= 18.5 lbs.
Partial pressure of ammonia.....	137.4 lbs.
Saturation temperature ammonia.....	73.5° F.
Superheat.....	166.5° F.
Heat content ammonia.....	658.1
Specific volume ammonia.....	3.07
Saturation temperature steam.....	224° F.
Superheat.....	16° F.
Heat content steam.....	1162
Specific volume steam.....	22.0
Weight of steam with 1 lb. $\text{NH}_3 = \frac{3.07}{22.0}$	= 0.1395

The value of y may now be found

$$0.25y - 0.175 [y - (1 + 0.1395)] = 1$$

$$y = \frac{1 - 0.1995}{0.075} = 10.65$$

This is weight of liquor at 25 per cent. concentration entering the generator.

The weight of weak liquor leaving is

$$(10.65 - 1.1395) = 9.5105 \text{ lbs.}$$

of 17.5 per cent. concentration. This passes to the absorber.

The amount of ammonia absorbed by bringing this solution to a concentration of 25 per cent. is given by

$$[9.5105 (1.00 - 0.175) \frac{100}{75} - 9.5105] = 10.461 - 9.5105 = 0.9505$$

This is the amount of ammonia absorbed but there is still a further amount absorbed by the water in the rectifier and analyzer. That leaving the rectifier includes a further amount, although small, which is taken over by the condensed moisture formed from the moisture leaving the rectifier and passing into the condenser and from it into the expansion coils and absorber.

The amount of water vapor leaving the rectifier must now be found.

Conditions at discharge of rectifier:

Total pressure.....	154.9 lbs.
Temperature.....	90° F.
Concentration of liquor leaving.....	70 per cent.
Partial steam pressure $\left[0.696 \times \frac{1700 - 17 \times 70}{1700 + 70} \right]$ =	0.20 lbs.
Partial ammonia pressure.....	154.7 lbs.
Temperature saturation of ammonia.....	80.3° F.
Superheat ammonia.....	9.7° F.
Heat content ammonia.....	564.4 B.t.u.
Specific volume ammonia.....	1.99 cu. ft.
Temperature saturation of steam.....	53° F.
Superheat steam.....	37° F.
Heat content.....	1100 B.t.u.
Specific volume.....	1640

From this the amount of moisture leaving per pound of ammonia is

$$\frac{1.99}{1640} = 0.0012$$

The amount of ammonia absorbed by this amount of water, if condensed, to produce a 25 per cent. concentration is

$$0.0012 \times \frac{25}{75} = 0.0004$$

Hence for every pound of ammonia absorbed 0.9996 lb. will be absorbed by the weak liquor and 0.0004 lb. will be absorbed by the water sent in from condenser.

Since the actual weak liquor absorbs 0.9505 lb. per pound of ammonia, the total weight of ammonia absorbed to make the strong liquor is

$$\frac{0.9505}{0.9996} = 0.9509 \text{ lb.}$$

and the weight of strong liquor is

$$9.5105 + 0.9505 + 0.9509 \times 0.0016 = 10.4625$$

This liquor at 145° F. is passed through the interchanger which is supplied with 9.5105 lbs. of weak liquor at 240° F. The heat given up by this liquor in reducing its temperature to 150° F. by the countercurrent interchangers is equal to

$$Q = 9.5105 [240 - 150] \times 1 = 856 \text{ B.t.u.}$$

This assumes that the specific heat of the liquor is 1.

If a 20 per cent. radiation loss is assumed from the interchanger the temperature of the strong liquor leaving this apparatus and entering the analyzer is

$$\frac{0.80 \times 856}{10.4625} + 145 = 210.5$$

This strong liquor is mixed with a small amount of liquor of higher concentration but at 90° F. from the rectifier. This will decrease the temperature although the heat developed by the solution of the strong liquor will increase this latter temperature. The net effect is to decrease the temperature about 3½°. The exact amount of decrease will be found but to get the quantity of liquor from the rectifier for first approximation it will be well to assume a 3½° drop rather than no drop at all.

The gases from the analyzer will be brought to the temperature of the liquors entering the top of the analyzer by the cooling effect of these as the heat of superheat is much less than the heat required to raise the temperature of the liquor to that at the desired discharge into the generator from the analyzer. The conditions of the vapors leaving the analyzer and entering the rectifier are fixed by the temperature and pressure at this point.

Pressure.....	155.4 lbs.
Temperature assumed.....	207° F.
Concentration $\left[\frac{80.6 + 460}{207 + 460} = 0.00466x + 0.656 \right] x =$	33.2
Partial pressure steam $\left[13.3 \times \frac{1700 - 17 \times 33.2}{1700 + 33.2} \right] =$	8.72 lbs.
Partial pressure ammonia.....	146.7 lbs.

Temperature saturation ammonia.....	77.2° F.
Superheat ammonia.....	129.8° F.
Heat content ammonia.....	638.9
Specific volume ammonia.....	2.71
Temperature saturation steam.....	187° F.
Superheat steam.....	20° F.
Heat content steam.....	1149.3
Specific volume steam.....	45.1

$$\text{The water vapor per pound of ammonia} = \frac{2.71}{45.1} = 0.06.$$

Since the water vapor leaving the rectifier per pound of ammonia is 0.0012, the amount of water removed from the rectifier per pound of ammonia leaving the rectifier is

$$0.06 - 0.0012 = 0.0588$$

In addition to this the amount of moisture associated with the ammonia absorbed is also condensed, call this latter M . The concentration of the liquor leaving the rectifier for the analyzer is 70 per cent. Hence

$$\left\{ [0.0588 + M] \frac{70}{30} \right\} 0.06 = M$$

$$0.0588 \times \frac{7}{50} = M \left[1 - \frac{7}{50} \right]$$

$$M = 0.00957$$

Hence the moisture condensed per pound of ammonia entering the condenser is

$$0.0588 + 0.0096 = 0.0684$$

and for 0.9505 lb. of ammonia this is 0.065.

The ammonia absorbed by this is

$$0.065 \times \frac{70}{30} = 0.1517$$

The amount of liquor passing from rectifier is then

$$0.1517 + 0.065 = 0.2167 \text{ lb.}$$

This is at a temperature of 90° F.

On mixing with 10.4625 lbs. of strong liquor at 210.5° F. the temperature of the mixture is given by:

$$T = \frac{10.4625 \times 210.5 + 0.2167 \times 90}{10.6792} = 208.05$$

The concentration of this mixture is now found.

Ammonia from strong liquor	=	10.4625 × 0.25 = 2.61572
Ammonia from rectifier liquor	=	= 0.15170
Total ammonia.....		2.76742
Concentration =	$\frac{2.76742}{10.6792}$	= 25.913 per cent.

The temperature of such a concentration at a pressure of 155.4 lbs. is given by:

$$\frac{80.6 + 460}{T_{sol.}} = 0.00466 \times 25.91 + 0.656$$

$$T_{sol.} = 697^\circ \text{ abs.} = 237^\circ \text{ F.}$$

Since the temperature of the mixture is below this point the solution would remain of strength given were it not for the heat of solution when the stronger rectifier liquor is diluted in the strong liquor.

To change 10.4652 lbs. of liquor from strength 25 per cent. to 25.91 per cent. requires an amount of ammonia equal to

$$10.4625 [0.2591 - 0.25] = 0.0955$$

This should also equal the ammonia lost by the rectifier liquor

$$0.2167 [0.70 - 0.25913] = 0.0955.$$

The mixture of a strong solution in a weaker solution develops heat. This may be considered as the difference between the heat developed when the weak solution is made strong and that required to weaken the strong solution.

Heat =

$$\begin{aligned} & 0.0955 \left[893 - 142.5 \left(\frac{25913}{74087} + \frac{25}{75} \right) - 893 + 142.5 \left(\frac{70}{30} + \frac{25913}{74087} \right) \right] \\ & = 0.0955 \left[\frac{70}{30} - \frac{25}{75} \right] 142.5 \\ & = 0.0955 \times 142.5 [2.33 - 0.33] \\ & = 27.22 \end{aligned}$$

This heat is used to raise the temperature of the mixture and part may be used to drive off ammonia if the temperature becomes greater than the temperature of solution for the actual concentration at the given pressure. The temperature rise for 27.22 B.t.u. is

$$\frac{27.22}{10.6792} = 2.55^\circ \text{ F.}$$

This gives $208.05 + 2.55 = 210.55^\circ \text{ F.}$

This is less than 237° F. and hence there is no evaporation. If this were higher it would be well to assume an intermediate temperature a little above the solution temperature for the pressure and concentration and compute the concentration for this temperature. Then the amount of ammonia and water vapor driven off would be computed together with the heat required to do this. If the assumed temperature were correct, this heat together with the heat to raise the solution from 208.7 to the assumed temperature would equal 27.22 B.t.u. If the sum is greater, a lower temperature is assumed and the quantities computed. After several assumed temperatures the correct one may be interpolated.

In any case the final answer gives the temperature at the discharge from the analyzer and the second value of condensation in the rectifier may be found. The actual conditions at discharge from the analyzer into the rectifier are as follows:

Pressure.....	155.4 lbs.
Temperature.....	210.25° F.
Concentration.....	32.3
Partial steam pressure.....	9.39 lbs.
Partial ammonia pressure.....	146.01 lbs.
Temperature saturation ammonia.....	76.9° F.
Superheat ammonia.....	133.3° F.
Heat content ammonia.....	640.9
Specific volume ammonia.....	2.73
Temperature saturation steam.....	190° F.
Superheat steam.....	20.25° F.
Heat content steam.....	1151
Specific volume steam.....	42.4
Water vapor per lb. of ammonia.....	0.0644

Water condensed per lb. of ammonia passing into condenser

$$0.0644 - 0.0012 = 0.0632$$

$$M = 0.0644 \left[0.0632 + M \right] \frac{70}{30}$$

$$= 0.01117$$

Total moisture = 0.0632 + 0.01117 = 0.0744 per lb.

Moisture for 0.9509 lb. = 0.0707

Ammonia absorbed = $0.0707 \times \frac{70}{30} = 0.165$

Liquor from rectifier = 0.165 + 0.0707 = 0.2357

Temperature of mixture = $\frac{10.4625 \times 210.5 + 0.2357 \times 90}{10.6982} = 207.84$

Concentration of mixture = $\frac{2.7807}{10.6982} = 25.99$ per cent.

Temperature solution = 696° abs. = 236° F.

Ammonia taken up by weak solution

$$10.4625 [0.2599 - 0.25] = 0.1036$$

Ammonia given up by strong solution

$$0.2357 [0.70 - 0.2599] = 0.1037$$

Heat of change of solution $0.1037 \left[\frac{70}{30} - \frac{25}{75} \right] 142.5 = 29.55$

Temperature rise = $\frac{29.55}{10.6982} = 2.76^{\circ}$ F.

Temperature of discharge = $207.84 + 2.76 = 210.6^{\circ}$ F.

This is below 236° F., hence there is no further change of concentration and the condition of the entrance into rectifier of 210.25 may be used as the difference in temperature does not change data.

The ammonia entering rectifier is therefore

$$0.9509 + 0.165 = 1.1159$$

The vapor entering is given by two methods:

$$\text{Vapor} = [0.0744 + 0.0012] 0.9509 = 0.0719$$

$$\text{Vapor} = 1.1159 \times 0.0644 = 0.0740$$

$$\text{Mean value} = 0.073$$

The liquor at temperature 210.25° F. drops through the analyzer and receives heat from the hot vapors. As this heat is not sufficient to heat the liquor to 240° F., it will be assumed that a steam coil is used to supply the necessary heat which will be computed. The liquor is assumed to leave at 240° F. The conditions for this are given for exit from generator on p. 440.

Since it is known that the discharge from the generator is 1 lb. of ammonia and 0.1395 lb. of steam, at each point of the apparatus the amount of substance is known.

This can be put in tabular form:

GENERATOR:

Entering.—10.65 lbs. liquor of 25 per cent. concentration at 240° F.

Leaving.—1 lb. ammonia vapor at 240° F.

0.139 lb. water vapor at 240° F.

9.501 lbs. of liquor of 17.5 per cent. concentration at 240° F.

ANALYZER:

Entering.—1 lb. ammonia vapor at 240° F.

0.139 lb. of water vapor at 240° F.

10.67 lbs. liquor of 25.99 per cent. concentration at 210.6° F.

ANALYZER:

Entering.—Heat of 1 lb. ammonia = $1 \times 658.1 =$	658.1
Heat of 0.1395 lb. steam = $0.1395 \times 1162 =$	162.0
Heat of liquid of liquor = $10.67 [210.25 - 32] =$	1910.0
Heat of solution = $-0.2599 \times 10.7 \left[893 - 142.5 \times \frac{2599}{7401} \right] = -2340.0$	
	390.1

Leaving.—Heat of liquid of 10.65 lbs. = $10.65 [240 - 32] = 2218$	
Heat of solution = $-0.25 \times 10.65 \left[893 - 142.5 \times \frac{25}{75} \right] = -2255$	
Heat of 1.116 lbs. ammonia = $1.116 \times 640.9 =$	716.0
Heat of 0.074 lb. steam = $0.074 \times 1151 =$	85.2
	764.2

$$\text{Net amount added} = 764.2 - 390.1 = 374.1$$

Total amount added in generator and analyzer allowing 20 per cent. for radiation is

$$120 [1397.1 + 374.1] = 2125 \text{ B.t.u.}$$

Pounds of steam required at 30 lbs. gauge and $x = 0.9$ is given by

$$M_{st} = \frac{2125}{0.9 \times 927.9} = 2.55 \text{ lbs.}$$

RECTIFIER:

Entering.—Heat of 1.116 lbs. ammonia =	716.0
Heat of 0.074 lb. steam =	85.2
	801.2

Leaving.—Heat of 0.9509 lb. ammonia = $0.9509 \times 564.4 =$	536.0
Heat of 0.0011 lb. steam = $0.0011 \times 1100 =$	1.2
Heat of liquid of 0.236 lb. liquor = $0.236 [90 - 32] =$	13.7
Heat of solution = $-0.7 \times 0.236 \left[893 - 142.5 \times \frac{70}{30} \right] = -92.5$	
	458.4

$$\text{Net heat abstracted} = 801.2 - 458.4 = 342.8 \text{ B.t.u.}$$

CONDENSER:

Entering.—Heat of 0.9509 lb. ammonia =	536.0
Heat of 0.0011 lb. steam =	1.2
	537.2

Leaving.—Heat of liquid of 0.9059 lb. ammonia = $0.9059 \times 53.6 =$	51.0
Heat of liquid of 0.0011 lb. water = $0.0011 \times 48.1 =$	0.0
Heat equivalent of $ApV =$	0.0
	51.0

$$\text{Net heat abstracted} = 537.2 - 51 = 486.2 \text{ B.t.u.}$$

EXPANSION COIL:

Entering.—Heat of ammonia =	51.0
Heat of water =	0.0
	51.0

Leaving.—Heat of ammonia vapor = $0.9505 \times 541.2 =$	514.0
Heat of water vapor = $0.0015 [10 - 32] =$	- 0.0
Heat of solution = $- 0.004 \left[893 - 142.5 \times \frac{25}{75} \right] =$	- 3.4
	<u>510.6</u>

(Work of liquid neglected.)

Heat abstracted $510.6 - 51 = 459.6$

Tons of refrigeration per pound of vapor per minute:

$$\frac{459.6}{200} = 2.3 \text{ tons}$$

ABSORBER:

Entering.—Heat of liquid of liquor = $9.501[150 - 32] =$	1120.0
Heat of solution of liquor = $- 0.175 \times 9.501[862.7] =$	- 1435.0
Heat of ammonia =	514.0
Heat of liquor =	- 3.4
	<u>195.6</u>

Leaving.—Heat of liquid of liquor = $10.463 [145 - 32] =$	1180
Heat of solution = $- 0.25 \times 10.463 [845.5] =$	- 2215
	<u>- 1035</u>

Net heat abstracted = $195.6 - (- 1035) = 1230.6$

INTERCHANGER:

Entering.—Heat of liquid of strong liquor = $10.463 [145 - 32] =$	1180.0
Heat of liquid of weak liquor = $9.501[240 - 32] =$	1975.0

$$\text{Heat equivalent of work} = \frac{1}{778} \left[155.4 - 37.5 \right] \times \frac{144 \times 10.463}{62.5 \times 0.913} = \frac{2.65}{3157.6}$$

$$\left[\text{Density} = 1 - \frac{4.3}{1000} \left(25 - \frac{25^2}{100} + \frac{35^3}{10000} \right) = 0.913 \right]$$

Leaving.—Heat of liquid of strong liquor = $10.463 [210.5 - 32] =$	1865
Heat of liquid of weak liquor = $9.501[150 - 32] =$	1120
	<u>2985</u>

Heat radiated = $3157.6 - 2985 = 172.6 \text{ B.t.u.}$

The work = $2.65 \text{ B.t.u} = \frac{2.65}{42.42} \times 2 = 0.125 \text{ h.p. for 1 lb. of ammonia per minute with 50 per cent. efficiency.}$

HEAT BALANCE:

	Taken in	Given out
Generator.....	{ 1397.1 374.1 }	354.0
Analyzer.....	{ 354.0 }	
Rectifier.....		342.8
Condenser.....		486.2
Expansion coil.....	459.6	
Absorber.....		1230.6
Pump.....	2.65	
Exchanger.....		172.6
Total.....	2587.4	2586.2

The cooling water entering the condenser at 50° F. is raised to 65° F. This could then go to the rectifier where its temperature could be raised to 75° F. and finally to the absorber where the temperature could be increased to 130° F. The weights of water would then be:

$$\text{Wt. for condenser per 1 lb. ammonia liberated} = \frac{486.2}{15} = 32.2$$

$$\text{Wt. for rectifier per 1 lb. ammonia liberated} = \frac{342.8}{10} = 34.3$$

$$\text{Wt. for absorber per 1 lb. ammonia liberated} = \frac{1230.6}{55} = 22.4$$

The amount of water actually needed is 34.3 lbs.

The surface required in these different sections is found by methods of Chapter III.

The other data computed for the other refrigerating machines will be computed for comparison.

$$\text{Tons of refrigeration per lb. ammonia} = \frac{459.6}{2000 \times 144} = 0.00159$$

$$\text{Tons of ice melting capacity per lb. coal} = \frac{459.6 \times 8}{2.55 \times 2000 \times 144} = 0.005$$

(Assuming 8 lbs. of steam per lb.)

$$\text{Tons of ice melting capacity per lb. steam} = \frac{0.005}{8} = 0.0006$$

The brine pump would require $0.125 \times \frac{120}{60} = 0.25$ lb. of steam per minute for 459.6 B.t.u. of refrigeration or 2.55 lbs. of steam in generator. Hence the exhaust from the pump can be used easily for part of the steam supply.

$$\text{Gallons of cooling water with } 15^\circ \text{ rise per ton of refrigeration} = \frac{34.3}{8.35 \times 0.00159} = 2580.$$

REFRIGERATING EFFECTS FOR 25° F. ROOM WITH COOLING WATER AT 50° F. HEATED TO 65° F.

Refrigerating machine	Coefficient of performance with friction	B.t.u. of refrigeration per ft.-lb. of work	B.t.u. of refrigeration per h.p.-hr.	Tons of ice melting capacity per 24 hr. per h.p.	Tons of ice melting capacity per 24 hr. per lb. coal (3 lb. per h.p.-hr.)	Tons of ice melting capacity per cu. ft. drawn into cylinder	Gallons of cooling water for 15° rise per cu. ft. drawn in.	Gallons of cooling water per ton of ice melting capacity	Tons of refrigeration per lb. steam (30 lbs. per h.p.-hr.)	High pressure	Low pressure
Moist Air.....	1.24	0.00159	3,120	0.26	0.00361	8.5×10^{-6}	0.0305	2180	0.00036	58.8	14.7
Dry air.....	1.26	0.00162	3,180	0.264	0.00368	9.0×10^{-6}	0.0306	2070	0.00037	58.8	14.7
Ammonia wet.....	5.22	0.00673	13,200	1.10	0.0153	235×10^{-6}	0.628	2670	0.00153	153.9	38.02
Ammonia dry.....	4.80	0.00617	12,200	1.02	0.0142	238×10^{-6}	0.644	2700	0.00142	153.9	38.02
CO ₂ (wet).....	11.9	0.0131	26,000	2.17	0.0301	965×10^{-6}	2.35	2430	0.00305	936.0	362.8
SO ₂ (wet).....	5.61	0.00725	14,350	1.195	0.0167	87×10^{-6}	0.23	2640	0.00165	59.65	13.5
Ammonia absorption.....					0.0050			2580	0.00060	155.9	37.52

From the above it is seen that CO_2 gives a much larger capacity per cubic foot and is much better for efficiency as shown by tons of refrigeration per pound of coal or steam. The air machines have small capacities per cubic foot and are very inefficient. The absorption machine for the conditions shown is not as efficient as the compression apparatus although if waste steam may be used this has a great value. The high pressure necessary on the CO_2 machine is the objectionable feature of this.

TOPICS

Topic 1.—Sketch and describe the action of an air refrigerating machine. Give expressions for the heat on each line. Explain what is meant by performance or refrigerative effect.

Topic 2.—Sketch and describe the action of a refrigerating machine using a volatile fluid and its vapor. Sketch the T - S diagram and from it give the expressions for the heat on each line. Explain what is meant by performance. Explain what is meant by a ton of refrigeration.

Topic 3.—Sketch and explain action of the absorption refrigerating machine. Give the function of each part of this apparatus.

Topic 4.—Explain method of finding the temperatures and pressures of the various points on the air cycle and ammonia cycle of a refrigerating machine. What is a dense air machine? Give the expressions for work, heat removed by the cooling water in each case and heat removed from the refrigerator.

Topic 5.—What is the effect of clearance? Show this completely. What is the effect of friction? Give the expressions for the power necessary for air and ammonia machines per pound of substance used. How is the volume of the compressor found? That of the expander?

Topic 6.—What is the effect of moisture in an air machine? Derive an expression for the work in the expander when moisture is present and when no moisture is present. Derive expressions for the work of the compressor with and without moisture. From the expressions above write the expressions for work with and without friction.

Topic 7.—What vapors are used for refrigerating machines? What are the advantages of one over the other? What is meant by wet and dry compression? Which is the better? Why? What is the clearance factor? Sketch T - S diagrams for each and explain action. Why is the expansion valve used? Write the expressions for work, heat and refrigerating effect.

Topic 8.—What is aqua ammonia? What is the effect of adding ammonia to water? What is the effect of adding aqua ammonia to water? What fixes the pressure at which ammonia will be given off from aqua ammonia at a certain temperature? What fixes the partial pressures of the ammonia and water vapors discharging from this solution? What is meant by per cent. ammonia or per cent. concentration?

Topic 9.—What is the heat of complete dilution? Complete absorption? Partial absorption? What is manner of variation of the density of aqua ammonia? What value is assumed for the specific heat of aqua ammonia?

Topic 10.—Outline the analysis of the action of the absorption machine. What data is assumed and what does this fix?

PROBLEMS

Problem 1.—An air machine is closed and operates between 40 lbs. gauge and 200 lbs. gauge with cooling water at 60° F. to 75° F. and a room held at 5° F. Find the temperatures at the various corners. Find the horse-power per ton of refrigeration with 10 per cent. friction effect. Find the cubic feet of displacement per minute in each cylinder and the amount of cooling water per minute per ton of refrigeration. Clearance 5 per cent. on each cylinder.

Problem 2.—An air machine is to operate under conditions of Problem 1 except that it is open and operates to 45 lbs. gauge pressure. Find the quantities asked for in Problem 1.

Problem 3.—An ammonia machine operates with cooling water from 60° F. to 75° F. and cools a room with direct expansion to 5° F. Find the pressures used. Find the horse-power per ton of refrigeration with 10 per cent. friction effect and clearance 3 per cent. Find the amount of water per minute and the displacement per minute for 1 ton. (a) Solve this with wet compression. (b) Solve this with dry compression.

Problem 4.—Solve Problem 3 using CO₂ as the medium.

Problem 5.—Solve Problem 3 using SO₂ as the medium.

Problem 6.—A 25 per cent. solution is made by the addition of ammonia to a 10 per cent. solution of aqua ammonia. How much ammonia has been added per pound of original solution? What is the density of each solution? What heat is developed by this addition of ammonia?

Problem 7.—A 25 per cent. solution is to be boiled at 170 lbs. gauge pressure. At what temperature will it boil? At what temperature must this be heated if it is to be reduced to a 10 per cent. solution. What are the partial pressures above the 10 per cent. solution in this case?

Problem 8.—Find the amount of heat per pound of vapor in the vapors coming from a 10 per cent. solution of aqua ammonia boiling at 170 lbs. gauge pressure.

INDEX

Authors, Authorities, Inventors and Investigators

- Adams, 210
American Rad. Co., 101
Andrew, 360
Atkinson, 363
Avogadro, 27
- Ball, 233
Barnett, 359
Barr, 209
Barrus, 178
Barsanti, 359
Beau de Rochas, 360
Bernouilli, 279
Berthelot, 435
Bertrand, 39
Bisschop, 360
Boltzmann, 73
Boulvin, 189
Box, 348
Boyle, 26
Brillé, 80
Brown, 359
Buckingham, 314
Buffalo Forge Co., 101
- Callendar, 198, 204, 208
Carcanagues, 80
Carnot, 9, 11, 12, 13, 62, 170
Carrier, 343
Charles, 26
Clark, 233
Clausius, 167, 170
Clayton, 210, 214
Clerk, 360
Coker, 369
Corliss, 167
Cotterill, 198
Curtis, 302
- Dalby, 77, 80
Dalton, 28
- Davis, 174, 317
De Laval, 301
Dent, 156
Diesel, 364
Duchesne, 209
Dulong, 73, 403
Dupré Hertz, 39
Duhring, 356
- Fliegner, 60
Foran, 335
- Giffard, 275
Gilles, 360
Goodenough, 16, 17, 25, 39, 44, 45,
47, 215
- Hagemann, 99
Hall, 205
Halliday, 80
Harn, 183
Hausbrand, 99, 100, 356
Hautefeuille, 359
Heck, 199, 223
Heinrich, 209
Hilliwell, 360
Huygens, 359
- Ingersoll Rand Co., 120, 151
- Jelinek, 99
Jordan, 80, 92
Josse, 261
Joule, 2, 37, 100
- Kelvin, 8, 36, 37
Klebe, 44
Kneass, 277, 279
Knoblanch, 44, 45
Kreisinger, 94, 108

- Langen, 44, 360
 Le Chatelier, 44
 Lenoir, 359
 Linde, 44
 Lucke, 73, 464

 Mallard, 44
 Marks, 174, 198, 317
 Matteucci, 359
 Maxwell, 24, 75
 McIntire, 434
 McMullen, 96
 Mollier, 45, 47, 80, 99, 100, 434
 Moyer, 274, 292, 303

 Napier, 60
 Newcomen, 167
 Newton, 73, 359
 Nicolson, 80, 89, 90, 91, 198, 204, 208
 Nusselt, 75, 94

 Orrok, 97, 334, 335
 Otto, 360

 Papin, 167, 359
 Parsons, 305,
 Perman, 434
 Perry, 78, 198
 Petit, 73
 Porter, 167

 Rankine, 60, 167, 170, 172, 215
 Rateau, 272, 304, 349

 Ray, 94, 108
 Reeve, 189
 Reynolds, 77, 78, 167
 Rice, 198
 Richards, 156
 Ruggles, 348

 Sangster, 119
 Savery, 167
 Scoble, 369
 Ser, 80
 Spangler, 177, 344, 396, 434
 Stanton, 80, 91
 Stefan, 73
 Stodola, 269, 270, 271
 Stone, 215
 Street, 359
 Stumpf, 167, 226, 231
 Sultz, 167

 Thomsen, 435
 Thurston, 198
 Tyndall, 73

 Watt, 167
 Webb, 232
 Werner, 80
 Weymouth, 370
 Willans, 167, 226
 Worcester, 167
 Wright, 359

 Zeuner, 215

INDEX

Subjects

- Absorber, 433
- Accumulators, 348
- Adiabatic, 2, 5, 16, 31, 54
- Adiabatic action, 2
- Afterburning, 368
- Aftercooler, 120
- Air, excess, 404
 - motor, 151
 - pump, dry, 334
 - transmission, efficiency, 152
 - loss, 152
- Allowance for turbines, 328
- Ammonia, 428
 - aqua, 434
- Analysis, Hirn's, 183
 - proximate, 402
 - T-S*, 183
 - ultimate, 402
- Analyzer, 432
- Aqua ammonia, concentration, 434
 - density, 437
 - heat of absorption, 435
 - partial pressure, 434
 - properties, 433
 - specific heat, 437
- Ash and moisture, free basis, 402
- Availability, 1, 14, 62
 - conditions for, 14
 - loss of, 115
- Avogadro's law, 27
- Axial thrust, 300

- Back pressure, effect of, 177
- Binary engine, 261
- Blades, number of, 327
- Bleeding engines, 255
- Blowing engines, 119
 - tubs, 119
- Bone-Schnable boiler, 407
- Boyle's law, 26
- British thermal unit, 1

- Calorimeters, 178
- Capacities, thermal, 21
- Carbon dioxide, 430
- Cards, combined, 243
 - computation for, 243
 - construction, 243
- Characteristic equations, 19
- Charles' law, 26
- Charts, *I-S*, 47
 - T-S*, 47
- Coils for heating, 101
- Clearance, effect, 124, 417
 - effect eliminated, 418
 - factor, 125
 - ratio, 125
 - space, 125
 - steam, 170, 184
- Closed system, 412
- Combining tube, 281
- Combustion, 375, 402, 403
 - heat, 376
 - surface, 406
 - table, 377
- Complex cycle, 38
- Compound engine, 241
- Compounding for turbines, pres-
sures, 297
 - velocity, 297
- Compression, best point, 230
 - curve, 127
 - dry, 425
 - method, 128
 - temperature, 127
 - wet, 425
- Compressors, 118
 - air, 118
- Condensation, initial, 196
 - maximum, 207
- Condenser, ammonia, 98
 - barometric, 337
 - contraflo, 337

- Condenser design, 338
 dry tube, 337
 jet, 333
 steam, 97
 surface, 333
 uniflux, 337
 Conduction, 15, 72, 74
 coefficients, 95
 factors, 74
 Conductivity, 207
 Conservation of energy, 2
 Constant steam weight curve, 217
 universal gas, 27
 Consumption, computation, 224
 curves, 222
 steam, 173, 210
 Convection, 72, 75
 Converging nozzle, 273
 Cooling, loss from, 140
 towers, 341
 cost, 347
 size, 347
 Counter flow, 82
 Criterion for exact differentials, 4
 Critical pressure, 267
 temperature, 49
 Cross products, 37
 Curve, construction, 218
 expansion, 215
 pressure in nozzle, 269
 steam consumption, 222
 Curtis turbine, 302, 311

 Dalton's law, 28
 De Laval turbine, 301, 309
 Delivery tube, 282
 shape, 282
 Determination of K , 86
 Diagrams, combined, 240
 factor, 221
 I-S, 47
 Mollier, 47, 52
 temperature-entropy, 172, 175
 Differential effect of heat, 43
 exact, 3
 Diffusivity, 207
 Dilution, 368
 Discharge, 59
 Displacement of air compressor, 135

 Double bottoms, 356
 Drip pot, object of, 182
 Dry compression, 425, 429
 basis, 402
 test, 187
 Dulong's formula, 408
 Duty, 67

 Efficiency, 12
 actual, 63
 air standard, 362
 Carnot, 12, 14, 62
 change, 389
 conditions for maximum, 66
 cycle, 175
 equality, 12
 kinetic, 293
 maximums, 12, 13, 62, 65, 293
 mechanical, 63
 overall, 63
 practical, 63
 Rankine, 171, 173
 theoretical, 62
 transmission of heat, 103
 type, 63
 volumetric, 126
 Effects, single, double, quadruple,
 350
 End thrust, 306
 Energy, conservation, 2
 high grade, 1
 internal, 2
 intrinsic, 41
 Engine, air, displacement, 146
 power, 146
 work on, 138
 and turbine, combined, 329
 compared, 309
 binary, 261
 bleeding, 255
 heat, 62
 internal combustion, 359
 Mietz and Weiss, 366
 multiple expansion, 240
 Otto, 365
 receiver, 242
 regenerative, 256
 similar to turbine, 309
 size of, 229

- Engine steam, 167
 steam cycle, 170
 straight flow, 170
 Stumpf, 226
 tests, 67, 68, 178
 uniflow, 226
 Woolf, 242
 work, 246
- Entropy, 16, 37, 43, 47, 51
 around cycle, 18
 diagram, 19
- Equality of temperature scales, 36
- Equation, Bernoulli, 279
 characteristic, 19
 differential, 29
 fundamental, 21
- Equivalent evaporation, 410
- Evaporation, equivalent, 410
 factor, 410
- Evaporators, 98, 349, 350, 353
- Exact differential, 3
- Expansion, complete, 138
 curves, construction of, 218
 free, 172, 175
 incomplete, 138, 172, 175, 418
 line, 140, 215
 loss, 140
 ratio, 220
- Exploring tube, 269
- Explosion temperature, 389
- Exponent value, 214
- External work, 2, 31, 41
- Factor diagram, 221
 of evaporation, 410
 of safety, 100
- Fan blowers, 118
 power, 149
- Feedwater heaters, 98
- First law of thermodynamics, 2
- Flow, counter and parallel, 82
 of fluids, 56
- Free air, 123
- Friction factors, 292
- Fuels, blast furnace gas, 374
 coal, 402
 crude oil, 374
 gasoline, 374
 illuminating gas, 370
- Fuels, kerosene, 375
 lignite, 402
 natural gas, 370
 peat, 402
 produce gas, 371
 wood, 402
- Gas composition, 376
 engine, temperature, entropy-
 diagram, 392
 test, 69, 70, 396
 producer, 371-373
- Generator, 432
- Governing, air compressors, 149
 gas engines, 367
 steam engines, 235
 multiple expansion engines, 254
- Graphical representation of heat, 6
- Heat, balance, 402, 450
 content, 37, 42, 47, 51
 engine, 62
 graphical representation, 6
 internal, 41
 of liquid, 40
 of vaporization, 40
 on line, 6, 7, 35
 on path, 20, 42, 52
 transmission, 72, 75, 99, 103, 104
 efficiency, 103
- Hirn's analysis, 183, 260
- High grade energy, 1
- Humphrey compressor, 122
- Hyperbola, rectangular, 55, 217
- Hydraulic radius, 80
 compressor, 119, 122
- Ignition, 368
- Impact coefficient, 284
- Indirect heaters, 101
- Initial condensation, 196
- Injector, 275
 capacity, 284
 density of discharge, 283
 details, 281
 double jet, 284
 experiments, 277
 heat equation, 280
 lifting, 284

- Injector number, 282
 overflowing pressure, 285
 temperature, 285
 size, 282
 steam required, 281
 theory, 280
- Interchanger, 433
- Intercooler, 120, 121, 130
 heat removed, 133
 water for, 133
 from, 134
- Internal energy, 2
 heat of vaporization, 41
- Intrinsic energy, 2, 42, 47, 51
 change, 35
- Irreversible cycles, 15, 18
- Isodynamic, 6, 31, 54
 action, 2
- Isothermal, 7, 10, 31, 55
- Jacket, 121, 128, 253
 effect of, 234
 heat removed by, 128
 saving by, 129
 water for, 130
- Jet, force of, 287
 impulse of, 288
 reaction of, 288
 work of, 289
- Joule's equivalent, 2
- Kinetic energy change, 265
- Lagging, 254
- Latent heat, 21
- Law, 14
 Avogadro's, 27
 Boyle's, 26
 Charles', 26
 Dalton's, 28
 First Law of Thermodynamics,
 2
 Second Law of Thermody-
 namics, 14
 Stefan-Boltzmann, 73
- Leakage, effect of, 134
 factor, 125
 in pipes, 143
 of valves, 208
- Lines, thermodynamics, 33, 50
 gas-engine card, 392
- Locomobile, 235
 test of, 68
- Logarithmic diagrams, 153, 396
- Loss curves, 274
 of heat 186, 194
- Low-grade energy, 1
- Mats, 341, 347
- Maxwell's equations, 24
- Mean effective pressure, 219
- Missing quantity, 196
- Mixtures, gases, 28
- Molecular weights, 29
- Moisture, allowances, 328
 effect, 418
- Motors, air, 151
- Mouth of nozzle, 268
- Mouthpiece, 272
- Multistaging, 130
 reasons for, 135
- N-value of, 214
- Nozzle, 265, 268, 271
 converging, 273
 spray, 348
 steam, 281
 velocity, 278
- Open system, 412
- Orifices, 271, 272
- Overexpansion, 268
- Parallel flow, 82
- Parson's turbine, 305, 324
- Partitions, heat transmitted, 104
- Paths, 20
- Perfect gases, 19, 26
- Performance, method of reporting, 67
- Polytropic, 32
- Ponds, cooling, 348
- Potentials, thermodynamics, 24
- Power of motor, 126
- Preheater, 152
- Preheating, gain from, 145
- Pressure, allowances, 328
 change, effect of, 176, 177
 critical, 267

- Pressure drop in pipes, 141
 intermediate, 130
 mean effective, 219
 partial, 28, 334
 and volume of steam, 225
- Producer, gas, 371, 373
- Properties of aqua ammonia, 433
- Proximate analysis, 402
- Pumping engine, test, 69, 258
- Quadruple expansion engine, 241
- Quality, 40
- Radiation, 72
 factors, 74
- Radiators, 100
- Rateau, accumulator, 349
 orifice, 272
 turbine, 304, 323
- Ratio of expansion, 220
- Receiver engine, 242
- Rectangular hyperbola, 55, 217
- Rectifier, 432
- Refrigerating machines, absorption, 431
 air, 411
 dense air, 416
 displacement, 414, 427
 efficiency, 413
 open and closed, 412
 power, 427
 temperature range, 413
 vapor, 424
- Refrigeration, tons of, 414
 power required, 414
- Refrigerative effect, 427
 engines, 256
 performance, 413
- Refrigerator, 9
- Reheaters, 253
- Reheat factor, 312, 323, 324
- Relations, differential, 23
 trigonometric, 291
- Relative humidity, 342
- Reversible action, 10
- Rieman steam shock, 272
- Rotary blowers, 119
- Safety factor, 100
- Saturated steam, 20
- Scale of temperature, 7
- Second law of thermodynamics, 14
- Shock, steam, 272
- Simple cycle, 37
- Solutions, dilute, 99
- Source, 9
- Specific heat, 21, 30
 superheated steam, 30
- Speed, 233
- Stage compressors, 119
- Steam, 20, 39
 consumption, 173, 210
 curves, 222
 turbines, 287
 velocity, 278
 weight curve, 217
 working, 185
- Stefan-Boltzmann law, 73
- Still, Hodges, 353
- Superheat allowances, 328
 effect of, 176, 177, 234
- Superheated vapor, 44
- Sulphur dioxide, 431
- Taylor hydraulic compressor, 122
- Temperature, after compression, 127
 after explosion, 389
 boiling, 356
 critical, 49
 entropy analysis, 188
 diagram, 392
 gas-engine card, 364, 384
 gradient, 76
 intermediate, 133
 Kelvin's absolute scale, 8
 mean difference, 81
 scale, 7
 equality, 36
- Tests, analyses, 183, 188
 engines, 178
 gas engines, 396
 pumping engine, 258
- Thermal unit, British, 1
 capacities, 21
 relations of, 22
- Thermodynamic lines, 33
- Thermodynamics, fundamental, 1
- Thermometers, constant immersion, 181
- Throat of nozzle, 268

- Throttling action, 58, 123, 425
 loss from, 144
- Thrust, axial, 300
 end, 306
- Tons of refrigeration, 414
- Total heat, 41
- Transmission constants, 105
 heat, 72
 to boiling water, 99
- Trigonometric relations, 291
- Triple expansion, 241
- Tube exploring, 269
- Tubs, blowing, 119
- Turbine, compared with engine, 309
 combined with engine, 329
 computations, 309
 Curtis, 302
 deLaval, 301
 efficiency, 293, 307
 low pressure, 329
 maximum efficiency, 293
 mixed flow, 329
 Parsons, 305
 pressure, 291
 Rateau, 304
 steam, 167, 287
 test, 69
 velocity, 291
- Turbo compressors, 118
- Ultimate analysis, 402
- Underexpansion, 268
- Universal gas constant, 27
- Vacuum allowance, 328
- Valves, air, 136
 leakage, 208
- Vapor, 39
- Variables, independent, 20
- Velocity, actual, 289
 blade, 289
 discharge, 59, 265
 factors, 292
 injector, 278
 relative, 289
 whirl, 290, 292
- Vento heaters, 101
- Viscous liquids, 99
- Volume and pressure of steam,
 225
- Volumes, partial, 28
- Volumetric efficiency, 126
- Walls, effect of, 204, 369
 heat transmission, 104
- Water velocity, 278
- Weights, molecular, 29
- Wet compression, 425, 428
- Woolf engine, 242
- Work, 31
 compression, 123
 multiple expansion, 246
- Working steam, 170, 185
- Y, value of, 266



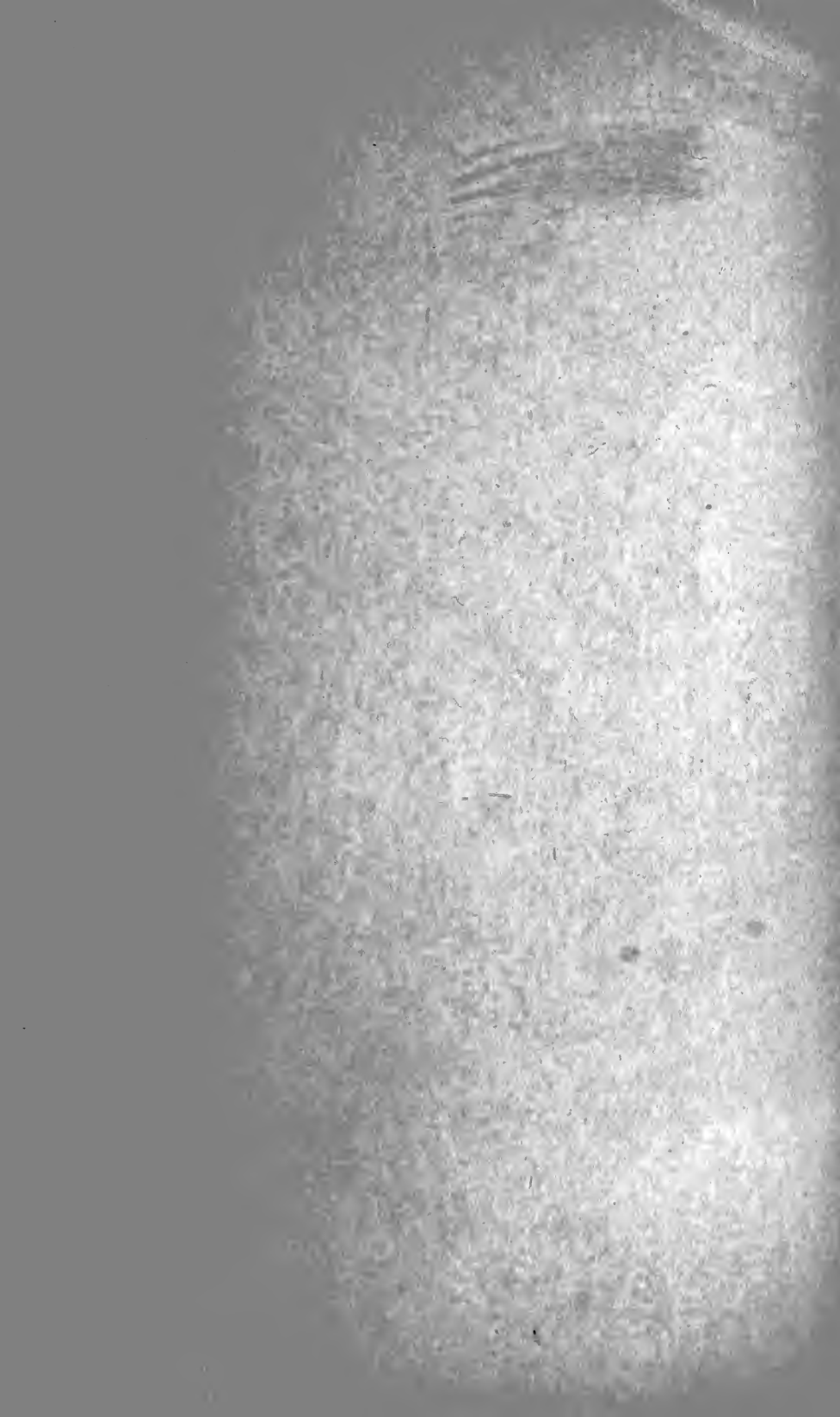



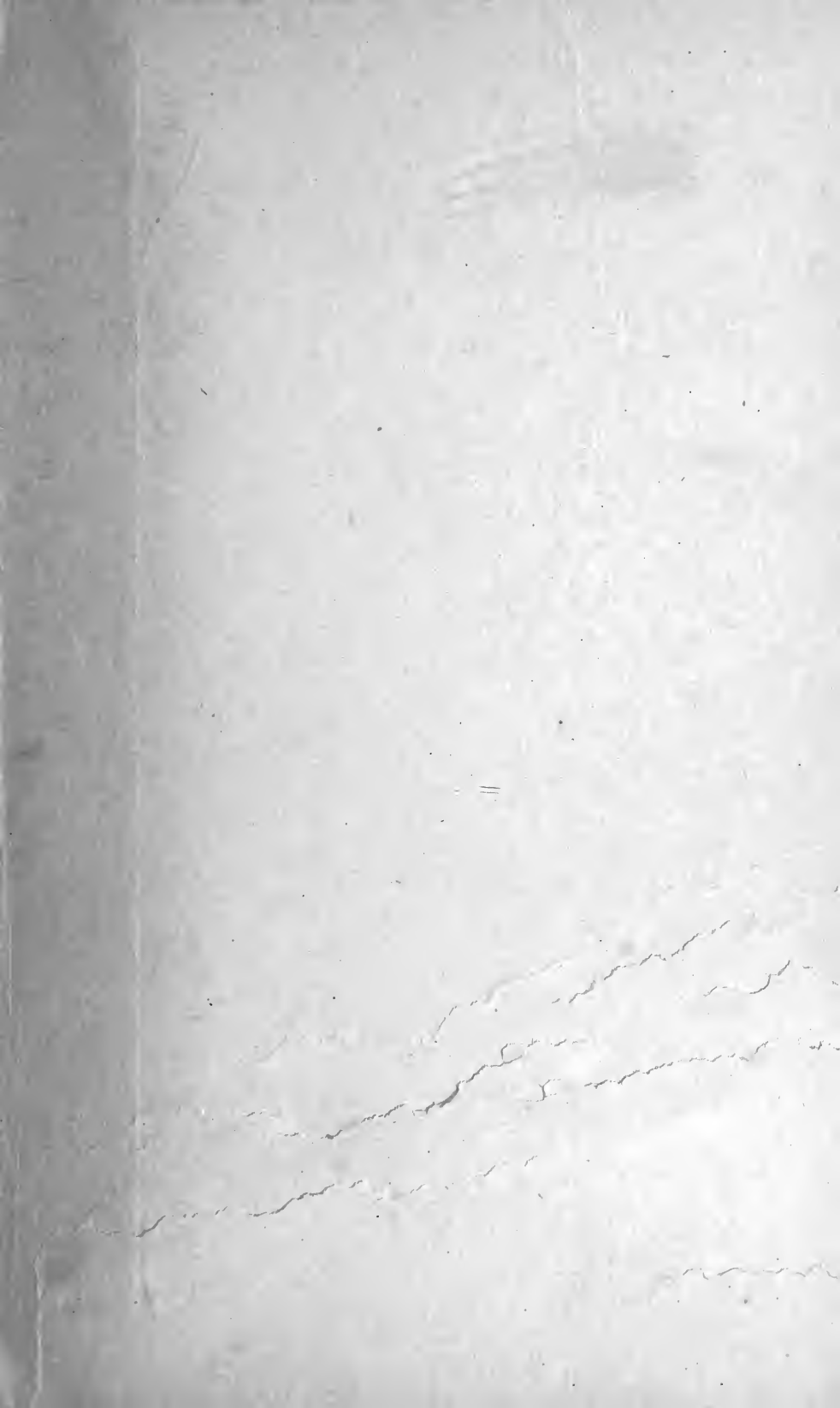

LIBRARY OF CONGRESS



0 021 225 350 9