

COOKERY

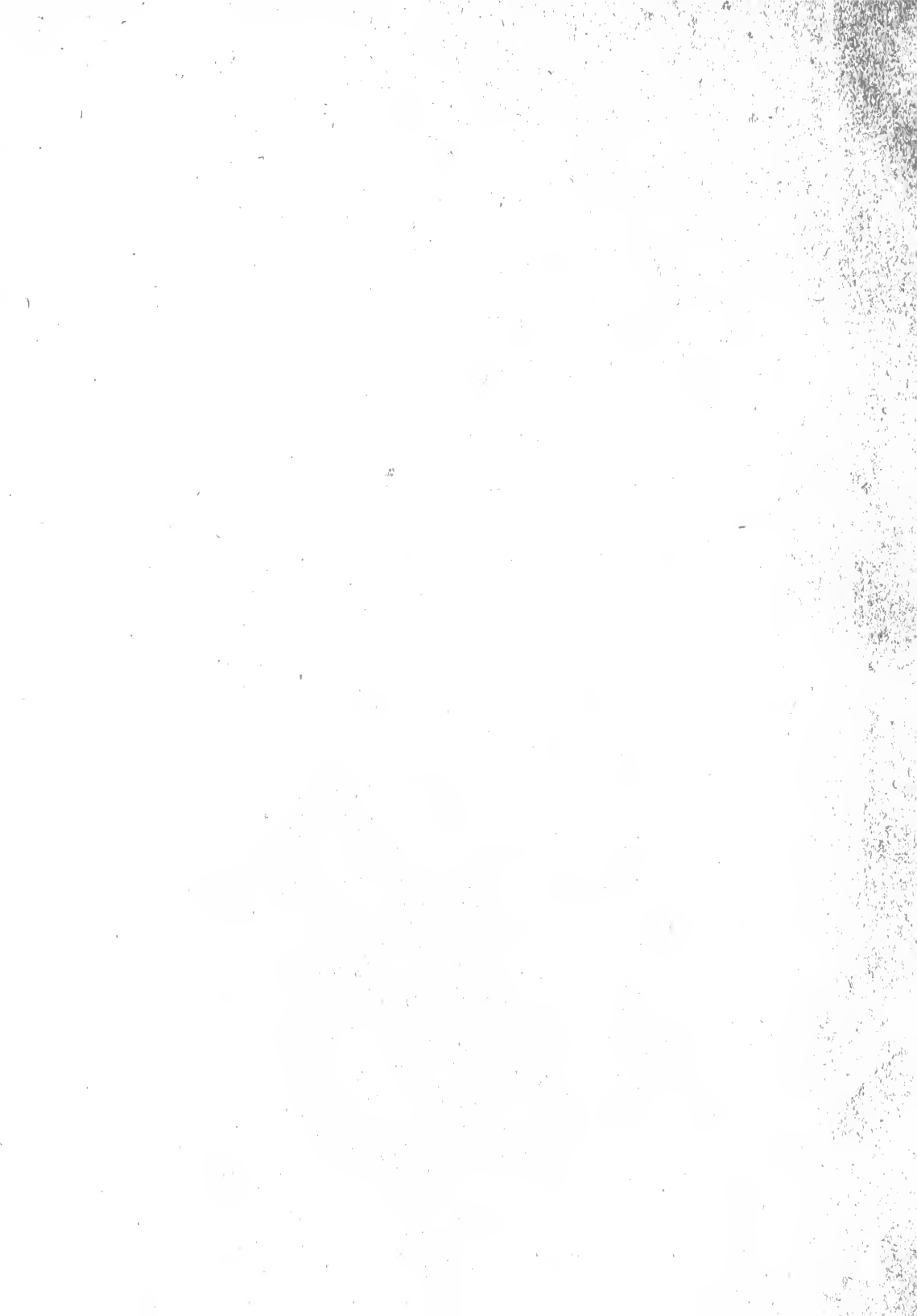

WILLIAMS AND FISHER



ELEMENTS
OF THE THEORY AND PRACTICE
OF COOKERY



THE MACMILLAN COMPANY
NEW YORK · BOSTON · CHICAGO · DALLAS
ATLANTA · SAN FRANCISCO

MACMILLAN & CO., LIMITED
LONDON · BOMBAY · CALCUTTA
MELBOURNE

THE MACMILLAN CO. OF CANADA, LTD.
TORONTO



PLATE I.



© Georgie Boynton Child.

DINNER-WAGON, OR BUTLER'S TRAY. A SAVER OF STEPS BETWEEN KITCHEN AND DINING-ROOM.

ELEMENTS
OF THE
THEORY AND PRACTICE OF
COOKERY

A TEXT-BOOK OF DOMESTIC SCIENCE FOR
USE IN SCHOOLS

NEW EDITION — REVISED AND ENLARGED

BY

MARY E. WILLIAMS

LATE DIRECTOR OF HOME ECONOMICS IN THE PUBLIC SCHOOLS
OF NEW YORK CITY AND DIRECTOR OF THE DEPARTMENT
OF HOME ECONOMICS IN NEW YORK UNIVERSITY

AND

KATHARINE ROLSTON FISHER

FORMERLY INSTRUCTOR IN HOME ECONOMICS IN THE
PUBLIC SCHOOLS OF NEW YORK CITY

New York

THE MACMILLAN COMPANY

LONDON: MACMILLAN & CO., LTD.

1916

All rights reserved

TX663
.W72
1916

COPYRIGHT, 1901, 1916,
By THE MACMILLAN COMPANY.

Set up and electrotyped. Published May, 1916.



Norwood Press
J. S. Cushing Co. — Berwick & Smith Co.
Norwood, Mass., U.S.A.

\$1.00

JUN -1 1916

©Cl.A433223

PREFATORY NOTE

THE continued demand for this textbook has prompted this new edition.

In preparing it, the first aim has been to bring the subject-matter up to date; the second, to adapt it for use in both rural and city schools in all parts of the country.

The text on Food in Relation to Life, the Preservation of Food, Food for Babies, and Digestion, has been largely rewritten. Two new chapters have been added, one on the Serving of Food, and one on Laundering. Every other chapter includes new matter which embodies the results either of scientific progress or of practical experience.

Among the many persons who have contributed to the preparation of this edition by giving information or by making helpful suggestions are Miss Cora M. Winchell, Assistant Professor of Household Arts Education at Teachers College, Columbia University; Dr. Hermann T. Vulté, Assistant Professor of Household Arts, Teachers College; Miss Sadie B. Vanderbilt, Instructor in Household Arts, Teachers College; Miss Amy Logan, Instructor in Household Arts, Horace Mann High School; Miss L. Belle Sage, Instructor in Biology, and Miss Ada Roe, Instructor in Household Economics, Washington Irving High School, New York City; Miss Helen Munch, Miss Clara Pancake, Miss Helen Banquo, Miss Mamie Gearing, Miss Marion C. Ricker, Dr. Augusta Rucker, Miss Agnes Daley, and Miss Eleanor Kalbfleisch.

Miss Florence Willard, Chairman of the Department of Household Economics, Washington Irving High School, has rendered valuable assistance in many ways.

Mrs. Max West, of the Children's Bureau, United States Department of Labor, has been of material assistance in the preparation of the section on Infant Feeding.

The authors desire to express their cordial thanks for the information courteously and readily given by many experts in the United States Department of Agriculture, among them Dr. Charles F. Langworthy, Miss Caroline L. Hunt, Mr. Robert Milner, and Mr. Harold L. Lang of the Office of Home Economics; Mr. L. A. Rogers of the Dairy Division, Dr. J. Arthur LeClerc, Dr. Martin N. Straughn, Mr. Carleton Bates, Miss Ruth Greathouse, Mr. Calvin G. Church, Mr. Walter C. Taber, Miss Anne E. Draper, and Mr. Edward M. Chase, of the Bureau of Chemistry. Miss Mary E. Cresswell, in charge of Girls' Canning Clubs, has read the manuscript of the sections on Microorganisms and Canning, and has assisted materially in the preparation of these and of some other portions of the book.

Especially are thanks due for the courtesies extended by Miss Claribel R. Barnett, Director of the Library of the United States Department of Agriculture, and the help given by her staff, including the staff of the branch in the Bureau of Chemistry.

The Household Arts Library of Teachers College has also been of service, and the privilege of its use is fully appreciated.

The proof has been critically read by Miss Margaret M. Holt, Miss Agnes Daley, Miss Jennie B. Jameson, and Miss Eleanor Kalbfleisch of the Department of Household Economics of the New York City Public Schools.

NOTES TO TEACHERS

THE plan of this textbook does not assume the employment of any one particular method of teaching cookery. The book can be used equally well whether the pupils work individually or in groups.

Recipes making quantities suitable for a small family are given, as being the most practicable from all points of view. The individual recipe is not adapted to home use, nor is it so easy to multiply as it is to divide the ordinary recipe to make the latter meet the requirements of individual practice.

The subject-matter in this book can be covered in four terms (two school years) by classes of girls in the sixth and seventh or seventh and eighth years of school, one two-hour lesson being given each week.

The chapter topics are taken up in an order that experience has shown to be a natural and convenient one. The progression has been carefully worked out, as a glance at the table of contents will show. Numerous cross-references, however, which enable the pupil readily to turn to related topics in any part of the book, make it practicable for the teacher to vary this order. Certain portions of the text are printed solid, *e.g.* Section 5 of Chapter I, and page 97 together with part of page 98, to indicate that they may, at the discretion of the teacher, be left until later in the course, without interfering with the continuity of the work.

On the other hand, the sections of a chapter are not necessarily to be taken up in the order in which they stand. In many

cases, subject-matter from different sections of the same chapter may properly be presented in one lesson. For example, Sections 2 and 3 of Chapter II would naturally be taken up together.

The subject of cleaning is treated in considerable detail (Chapter I, Section 3), both because of its importance as a part of a course in household science, and in order to facilitate the keeping of the school kitchen and its equipment in proper condition. Each pupil should be thoroughly familiar with this section, so that when called on to serve as housekeeper she should know how to perform her duties, and where to turn in the textbook to refresh her memory with regard to them.

With the exception of this section on Cleanliness and Cleaning, no part of the book is intended to be studied at home before being taken up in class. Sections 4 and 5 of Chapter I, both sections of Chapter V, and Chapter XV are designed to be used chiefly for reference.

Directions for performing experiments and for making tests and "studies" are explicit, in order that each pupil may carry them out individually, — at school, if conditions permit, if not, then at home.

A microscope is a desirable part of the equipment of a school kitchen, but if one is not available, drawings or charts showing the appearance of common foods and foodstuffs under the microscope may answer instead of an exhibition of the specimen itself.

In taking up a new topic, this book, as a rule, gives opportunity for some practice work before presenting any theory. Principles are taught in connection with their application, and the classification of foods and general statements about them are deferred until some practical acquaintance has been gained with typical foods and their chief constituents. It will be observed that the recipes in the section on Food for the Sick

(Section 2 of Chapter XI) are so classified and arranged that this section forms a review of the different classes of foods in the same order in which they are taken up in the preceding chapters.

Although beverages are grouped by themselves, they are treated independently of each other and of other topics, in order that they may be taken up separately whenever convenient. A lesson on tea may be given in connection with the study of water, tea-making thus forming the first practice work of the course. Instruction in the preparation of cocoa and chocolate can be given to better advantage after milk has been studied.

Opportunity is offered, especially by means of the experiments, "studies," and suggestions for reading and home work, for correlation with history, drawing, and the natural sciences. It is desirable that every teacher of household science should make the most of these opportunities, and should secure the coöperation of principal and grade-teachers in correlating, not these branches only, but English and mathematics as well, with the work of the school kitchen.



CONTENTS

INTRODUCTION

HOMES AND HOME-MAKING	PAGE 1
---------------------------------	-----------

CHAPTER I

PREPARATORY LESSONS

SECTION	
1. Fire and fuels	5
2. Water	22
3. Cleanliness and cleaning	29
4. Definitions, tables, rules	48
5. Household chemistry	55

CHAPTER II

SOME STARCHY PLANTS

1. The potato	59
2. Starch	67
3. Cereals; Breakfast foods	73
4. Wheat, the king of cereals	80

CHAPTER III

TISSUE-BUILDING FOODS: EGGS AND MILK

1. Eggs; Albumin	83
2. Milk; Butter; Cheese	93

CHAPTER IV

BREAD

SECTION	PAGE
1. Quick breads—Baking-powders	104
2. Flour	116
3. Macaroni and other flour pastes	120
4. Yeast bread—Yeast	123

CHAPTER V

FOOD IN ITS RELATION TO LIFE

1. Bodystuffs and foodstuffs	139
2. Diet	146

CHAPTER VI

MEAT, FISH, AND POULTRY

1. Meat: Its structure, composition, and cooking	150
2. Meat: Cuts, marketing, and food value	177
3. Poultry	194
4. Fish and shell-fish	200

CHAPTER VII

FUEL FOODS: FAT FROM ANIMALS AND OIL FROM PLANTS

1. Fats and oils	213
2. Cooking in fat: Frying and sautéing	218

CHAPTER VIII

FRUITS AND VEGETABLES

1. Fruits	227
2. Vegetables	237
3. Cream-of-vegetable soups	253
4. Salads	258

CHAPTER IX

SUGAR AND SWEETS

SECTION	PAGE
1. Sugar — Candies	265
2. Cakes and desserts	273
3. Ice-cream and water-ices	287
4. Pastry — Pies	201

CHAPTER X

THE PRESERVATION OF FOOD

1. Microorganisms in relation to food	294
2. Canning	298
3. Jam and jelly : Pectin	303

CHAPTER XI

SPECIAL DIETS

1. Food for babies.	309
2. Food for the sick	327

CHAPTER XII

TEA, COFFEE, COCOA

1. Tea	337
2. Cocoa and chocolate	343

CHAPTER XIII

THE SERVING OF FOOD

1. Table service	348
2. Preparing meals	356

CHAPTER XIV

Laundering	360
----------------------	-----

CHAPTER XV

Digestion	366
---------------------	-----



ELEMENTS OF THE THEORY AND PRACTICE OF COOKERY

INTRODUCTION

HOMES AND HOME-MAKING

The business of home-making. — Have you ever thought what an important business home-making is? The welfare of a nation is founded upon the welfare of families, and the welfare of a family depends upon its having a healthful, happy home.

Women the home-makers. — The home, as we know it, has grown out of the need of a shelter for family life. Parent birds build nests, not for themselves, but for their young. The first homes of human beings were caves. Women have always been the home-makers. In early times men spent their lives in hunting and fighting. The animals they killed they brought home for the women to cook. When they learned to raise grain, it was the women who crushed it or ground it between stones. Women made clay dishes and baked them by the fire or in the sun. For a long time after people became civilized and lived in comfortable houses, nearly everything used in each home was made in it. Up to a century ago, even, women made at

home cloth, soap, candles, and many other things which are now made in factories. As a rule, the only work we do or have done for us by others at home is housework; that is, cooking, cleaning, and laundry work.

Natural science and domestic science. — *Natural science* is what we know about nature, about earth and air and water, about fire and electricity and other natural forces, about plants and animals. *Applied science* is the use of this knowledge to improve our way of living. *Domestic science* is the application of natural science to housework. *Cookery* is often defined as the art of preparing food for the nourishment of the body. But cookery is taught in schools not merely as an art, but as a branch of domestic science. As such, it includes both *practice*, learning how to do things, and *theory*, learning why they should be done.

Home and school ought to work for the good of the nation. — In its mission of training children to be good citizens, the school needs help from the home. For without right home conditions, including a sufficient supply of suitable and well-cooked food, boys and girls cannot have the strong bodies and clear minds needed for doing school work while they are children, and for their life-work as men and women. Think, then, how important to the nation it is that home-makers should have a knowledge of Domestic Science!

Training for home-making. — All knowledge comes by study and practice; a girl spends two years, at least, in fitting herself to teach; a boy, even longer in learning a business or trade. Is special preparation less neces-

sary for home-making, which involves many kinds of work, some of them difficult, and which usually includes the noblest of all occupations, the care and training of children?

In studying Domestic Science, and particularly in studying Cookery, you will not only learn many interesting things that you would be unlikely to discover for yourself in doing housework at home, but you will find pleasure in the work itself. Because certain household duties may seem hard or unpleasant is no reason for considering housework unworthy of attention. Some people make hard work of housekeeping by doing it in an unthinking way; when, by putting their minds upon it, they might discover how to make it easier and pleasanter. Only by treating housekeeping as an honorable employment, worthy of our best thought and skill, can we bring about conditions of health, comfort, and happiness in our homes.

General value of domestic science. — It is true that there is less housework to be done than there used to be. Modern conveniences and the partial preparation of much of our food before we buy it lighten the housewife's burden. But more intelligence is needed to use these conveniences and select these foods.

It is true also that more women than formerly are doing work other than housekeeping. But all must eat, and therefore all young people, boys as well as girls, will find it worth while to learn about food, its preparation, and its uses in the body. For eating right is a help toward thinking and doing right.

Notable among American women is Ellen H. Richards, a professor of chemistry who devoted her life to solving household problems with the aid of science. She wrote: "The very essence of science is plasticity. If home life is to be saved, new forms must be found suitable for the time. The school of to-day must furnish the home of to-morrow with its weapons of defence. But the school of to-day must be in line with the scientific spirit of to-day, ever searching for the better way. Let us keep ever ready to take the next step. The right solution of keeping a happy healthy home will come at last."

BRIEF REFERENCE LIST

For further development of topics treated in this section see:—

- MASON: *Woman's share in primitive culture*. (Illustrations show primitive homes and home industries.)
- EARLE: *Home life in colonial days*.
- RICHARDS: *Art of right living*.
- BEARD: *American citizenship*. Ch. 2, Food, clothing, and shelter. Ch. 3, The family.
- TERRILL: *Household management*. Housekeeping a profession, pp. 5-16.
- HUNT: *Life of Ellen H. Richards*.

CHAPTER I

PREPARATORY LESSONS

SECTION 1. FIRE AND FUELS

Food is cooked chiefly by means of heat. Heat is commonly obtained by burning something. Let us learn what we can about fire.

A STUDY OF COMBUSTION

Experiments. A. Into a clean bottle pour a little clear lime-water; cork the bottle, and shake it so that the lime-water may come in contact with the air in the bottle. Do you see any change in the appearance of the lime-water?

B. Insert a splinter in a cork, light the splinter, and fit the cork into the neck of a bottle. What happens? Pour a little clear lime-water into the bottle and shake. Note the effect on the lime-water.

Air in which a splinter has been burned turns lime-water cloudy. It must therefore differ in some way from ordinary air.

The composition of air; formation of carbon dioxide by burning. — Air is a mixture of gases, chiefly *oxygen* and *nitrogen*. Wood contains *carbon*. When the splinter burns, the oxygen in the air and the carbon in the wood unite, forming a new substance, the gas *carbon dioxide*.

Nothing will burn in carbon dioxide. So when all the oxygen in the bottle is used, and carbon dioxide has taken its place, the fire goes out.¹

It is carbon dioxide that turns lime-water cloudy. As only carbon dioxide has this effect, a simple way to show its presence in air is to bring the air in contact with lime-water, as in Experiment **B**.

A STUDY OF COMBUSTION — CONTINUED

Experiments with a candle. **C.** Set a two-inch piece of candle on the table and light it. How does it burn? Notice the appearance of the flame. (Fig. 1, *a*.)

D. Set over the candle a lamp-chimney supported on two pencils or blocks of wood. (Fig. 1, *b*.) Notice how the flame has changed. Hold

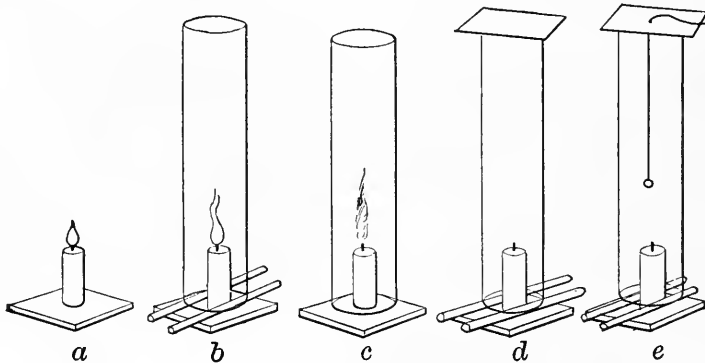

FIG. 1.

your hand for a moment about two inches above the chimney, and notice the heat felt. Hold a bit of tissue paper just above the chimney. Is it drawn upward or downward? Hold it near the space at the base of the chimney. Is it drawn outward or inward?

¹ The blackened part of the splinter which is left is unburned carbon (charcoal).

E. Remove the supports, letting the chimney rest upon the table. (Fig. 1, *c.*) Test for heat with your hand, then hold the bit of paper as before. Do you feel any heat? Does the paper move? What happens to the candle? Can you, by recalling the experiment with the splinter and the bottle, explain this?

F. Relight the candle, replace the chimney upon the supports, and cover the top with a piece of thick cardboard. (Fig. 1, *d.*) What happens? Explain. Removing the cardboard, quickly thrust a lighted splinter inside of the chimney. What gas do you think may be present?

G. Through a tiny hole in the cardboard pass a fine wire bent into a small loop at one end. Arrange candle and chimney as in Exp. D. Dip the wire loop into clear lime-water, which should form a film across the loop. Cover the chimney with the cardboard, letting the wire hang inside. (Fig. 1, *e.*) About two minutes after the candle goes out examine the film. What gas has been formed? Is the candle as large as it was before it was lighted? What has become of the part that has disappeared?

Explanation of the burning of a candle. — When a candle is lighted, the wax, by the heat of the burning match, is first melted, and then, being soaked up by the wick, is changed to gas. The oxygen of the air, always eager for something to unite with, seizes upon this gas; in other words, *the gas burns*. Whenever oxygen unites with another substance so rapidly that light and heat are given off, we have burning, or *combustion*. The light and heat we call *fire*. *Flame* is burning gas.

Drafts. — In still air a candle-flame streams straight upward. This is because hot air is lighter than cold air (p. 27). As the air near the flame becomes heated, it rises, and air from below flows toward the candle to take its place. This starts a draft. And, while the burning of the candle keeps up the draft, this draft supplies the candle with oxygen. When we place a lamp-chimney over the candle, leaving a

space at the bottom, we make the draft stronger by shutting off side-drafts. The flame flickers, and the candle burns faster. But if either the opening at the top of the chimney or the space between chimney and table be closed, all draft is stopped ; and as soon as the oxygen then inside the chimney is used up, the candle goes out. To keep up combustion, then, we must have a draft. For a draft through an enclosed space two openings are necessary, one to let air in, the other to let it out.

Products of combustion. — As the candle burns, it grows shorter. The wax is changed into carbon-dioxide, water-vapor, and other gases, which stream off unseen. The water is formed by the union of oxygen with hydrogen from the candle. Not all the carbon unites with oxygen. Some floats off in tiny particles. When there is enough unburned carbon to be visible, we call it smoke. When it is deposited, we call it soot. There are always enough carbon particles in a candle-flame to deposit soot on any cold object, such as a saucer, held in the flame. Anything that will not burn is said to be *incombustible*. A candle contains nothing incombustible, and so leaves no ashes.

Wherever combustion takes place, whether in fireplace, stove, or lamp ; whether a single match burns, or a whole building, something unites with oxygen, giving off heat (and usually light), and forming products of combustion.

In order to manage a kitchen fire successfully, we must understand the construction and purpose of every part of the range. Much fuel is wasted, food spoiled, and time lost because women do not take the trouble to do this.

THE COAL RANGE

Any cooking apparatus which burns coal is a range. The older term "cooking-stove" is sometimes applied to a small range on legs. A range is *set*, if it is built into the wall; *portable*, if it stands out in the room. It should stand upon a brick hearth, or a sheet of zinc, and the wall near it should be of brick or tiling, or else protected by zinc.

A coal range has the following parts:—

1. Fire-box, to contain fuel.
2. Grate, which forms the floor of the fire-box.
3. Dampers $\left\{ \begin{array}{l} a. \text{ Draft slide} \\ b. \text{ Check} \\ c. \text{ Oven} \\ d. \text{ Pipe} \end{array} \right\}$ to regulate draft.
 $\left. \begin{array}{l} c. \text{ Oven} \\ d. \text{ Pipe} \end{array} \right\}$ to direct current of hot air.
4. Ash-pan, to receive ashes, cinders, and clinkers (incombustible waste material and solid products of combustion).
5. Smoke-pipe, to carry off smoke (unburnt carbon) and gaseous products of combustion.
6. One or more ovens, for food.

Some ranges have other parts, — an oven for warming dishes, a reservoir to heat water, or a water-back, through which running water is carried to heat it, more dampers, etc.

The range in detail. — When the fire is out take off all the lids and as much of the top of the stove as is removable. Look first at the fire-box.

The *fire-box* is a rectangular space open at the top, lined on the sides with a fireproof material (*fire-bricks*), and having a movable grate for a floor.

Underneath the fire-box is the *ash-pan*. It should be emptied once a day, and the space around it brushed out.

The *pipe* connects the range with the chimney.

The *oven* in a stove or a portable range is back of the fire-box. In a set range there are generally two ovens, one on each side of the fire-box. An oven should contain a rack. Between the oven and the top, sides, and bottom of the range there is a space for the passage of air from the fire-box. This space must be cleaned occasionally to keep it from becoming choked with soot and ashes.

The *dampers* are slides or doors fitted to openings in the range. Below the fire-box is the draft slide. In the smoke-pipe is the pipe damper, provided with a hole to let gases escape when the damper is closed. At the back of each oven is an oven damper, usually moved by a rod extending to the front of the range.

Management of the dampers. — By opening the draft-slide, pipe, and oven dampers, a direct draft is produced, the air passing from below the grate, up through the fuel in the fire-box, and out into the chimney. This arrangement of dampers is used to start the fire, or to increase the heat of a fire already burning. If the draft slide be opened, and the pipe damper closed, when a fire is starting, the smoke will come into the room. Why?

By closing the oven damper, the air heated in the fire-box is made to flow around the oven before entering the chimney. By this means the oven is heated, and the force of the draft at the same time lessened by its having to make its way around corners. *Observe carefully the mechanism of the dampers. The range in your home may differ from the one at school.*

The *check damper* is above the fire-box. Opening it sends a stream of cold air across the top of the fire. Its effect is to check the fire by cooling it. Air admitted below the fire-box feeds the fire with oxygen.

NOTE. — There are several causes for poor draft besides fault in the range. The range may be clogged with soot and fine ashes, and need to be taken apart and cleaned. The chimney may not be built right. A tall building near by may cut off the draft.

HOW TO MAKE A FIRE

Cleaning the fire-box. — 1. Close all the dampers except the oven dampers.

2. Brush the ashes from the edge of the fire-box into the fire-box, and put the lid on.

3. Turn the grate over, so as to dump the ashes into the ash-pan. (If there is an ash-sifter in the range, the ashes will fall upon this, and must afterward be sifted through it into the pan.)

Laying the fire. — 4. Lay the fire: —

a. Fill the fire-box one-third full of shaving or wisps of paper twisted in the middle so as to expose a large surface to the air.

b. On these lay small sticks of soft wood or “kindling.”

c. Put two shovelfuls of coal on top of the wood.

The fuel should be arranged loosely in order that the air may have free passage through it.

5. Cover the top of the range. Open all the dampers except the check damper.

Starting the fire. — 6. Light the fire by applying a lighted

match between the bars of the grate to the paper or shavings inside. (If the stove is to be blackened, do it now.)

7. When the wood is all ablaze, add coal until the fire-box is level full. (As the wood burns away the coal will settle. The fire-box should never be kept more than three-fourths full.)

What to do when the fire is well started. — 8. When the blue flame disappears, close the oven dampers, and half close the draft slide. When the coal is burning well, close the draft slide entirely, and half close the pipe damper.

HOW TO MANAGE A FIRE

For a steady hot fire, rake out the ashes with a poker from beneath the grate; or, if the grate is a revolving one, give it one turn. Fill the fire-box three-fourths full of coal. Open the draft slide and pipe dampers. See that oven and check dampers are closed. When the coal in the lower part of the fire-box is glowing red, the top layer still black, and the flames yellow, close the dampers. When the top layer begins to glow, add more coal, so that there will always be black coals on top.

To check the fire slightly, open the slide in the check damper. To check it decidedly, open the check damper itself. All other dampers must be closed.

To keep a fire overnight. — Fill the fire-box with coal; close oven and pipe dampers and draft slide and open the check damper.

To heat the oven. — Close the oven damper.

Kindling-point. — Why is it, with active oxygen always

in the air, ready to devour, that chairs, tables, houses, do not take fire and burn? Simply because a substance must be heated to a certain degree before it will begin to unite with oxygen. Except for this, everything combustible would have burned up long ago. The temperature to which a substance must be raised before it will burn is its *kindling-point*. This point differs for different substances. See how we take advantage of this fact in starting a fire. We first light a match, the phosphorus¹ on which kindles from the friction of striking, and sets on fire the sulphur mixed with it, which has a somewhat higher kindling-point than phosphorus. The phosphorus in turn ignites the wood of the match, the kindling-point of which is higher still. Coal will not take fire from a match, because its kindling-point is so high that the match burns out before the coal becomes hot enough to burn; but paper may be lighted from a match, wood from burning paper, and coal from burning wood.

To start a fire three things are required: oxygen, fuel, and some means of raising the fuel to its kindling-point.

THE GAS RANGE

Cooking by gas is easy and cleanly. It saves space, unnecessary heat, and with care, expense. A combination coal and gas range is convenient where space is limited. For combination gas range and fireless cooker see p. 21.

Parts of a gas range. — A range of ordinary size has (1) several top burners, for saucepans, kettles, etc., (2) a

¹ *Pure* phosphorus burns, though slowly, at the ordinary temperature. It must, therefore, be kept under water.

baking oven, for bread, cake, and large roasts, (3) a broiling oven with rack and pan for steaks, chops, small roasts, toast, and dishes to be browned, (4) oven burners, situated inside and at the top of the broiling oven, and (5) under the baking oven. The situation of the ovens and the arrangement of the oven burners vary in different stoves. Most ranges have one small top burner, called a simmering burner. Some have an extra large one, a giant burner. A stove-pipe connected with a flue is desirable. A gas plate and portable oven answers for simple cooking. A stove for natural gas has the top burners covered, as natural gas produces smoke.

A gas-stove burner is designed to get as much heat as possible from the gas. The brightest flame is not the hottest. Its light is caused by bits of carbon which glow but do not burn. With more oxygen this carbon will burn, making the flame blue, sootless, and very hot. A "gas-cock" controls the flow of gas to each burner. Under each cock is an air-chamber with openings to admit air. If there is a "shutter" to regulate the size of the openings, turn it slowly and watch the flame. When just enough air is entering, the flame is blue, quiet, and steady. The "shutter" rarely needs adjusting, but the openings must be kept clear. The cause of a poor flame may be old choked-up pipes, not poor gas.

To manage a gas range. — Learn which pipes supply each burner; learn the position of each cock when open and when closed. Before lighting a burner, see that all burners are tightly closed and that no gas is escaping. To light a

top burner, strike a match, open the cock, let the gas flow for two or three seconds, and apply lighted match or taper at back of burner. Some ranges have a pilot-light which may be kept burning constantly for 8 cents a month, and from which any top burner may be lighted by pushing a button. Oven burners are usually lighted by a pilot-light at the side of the oven. To light oven burners, open both oven doors, strike a match, open the pilot cock, and light the pilot-light through the hole from the outside. Open the back oven cock, then the front one. Each burner will light with a slight explosive sound. When both are burning, turn off the pilot-light. See that gas burns blue the whole length of burners. If the gas pops and burns yellow with a roar, it has "struck back" and is burning in the air chamber. Turn it off at once, let it flow a few seconds, and re-light. If "striking back" occurs often, adjust shutter.

Light the baking oven from five to ten minutes before using. Two minutes after lighting it, open door to let moisture out, then keep it closed. After lighting the broiling oven close the door until the oven is hot. Leave door open while food is in the broiling oven. It will brown better. With the door closed, it may taste smoky or catch fire or the gas may go out for lack of air.

Care of gas range. — Keep drip sheet under top burners clean. Keep air-holes clear. Clean holes in burners with wire. Remove gratings and burners occasionally and clean them in boiling hot washing soda solution. (For further care see p. 15.)

To cook by gas safely, successfully, and economically,

observe these rules. 1. When you have finished using a burner turn it out at once.¹ 2. As soon as water or food boils or reaches the desired degree of heat, lower flame or remove utensil to simmering burner. Too low a flame may go out. If, turned higher, it gives too much heat, put an asbestos board over it. 3. Use a heat distributor, an iron sheet which spreads heat from one burner to several utensils. The right kind lets air pass between it and the flame. 4. To reduce oven heat, lower both burners. This saves as much gas as turning one out and keeps the oven more evenly heated. 5. Never have both upper and lower burners in a combination broiling and baking oven going at one time. The upper one is likely to go out for lack of air. One style of range is made so that lighting one set of burners prevents the others from being lighted.

FUELS

Anything that unites readily with oxygen may be used as *fuel*. Fuels common in American households are coal, wood, coal-oil (kerosene), and gas.

The story of coal. — Coal, by composition and structure, is shown to be of plant origin. Leaves, ferns, bark, whole tree trunks even, have been found turned to coal in mines. The slow process of decay that effected this change took place long before men lived on the earth, at a time when the

¹ There should be no key in connecting pipe which can be turned by hand. If there is, it should not be used instead of turning cock to shut off gas from stove, because an open cock may be overlooked, and when the gas is again turned on it will escape from this cock. In this way, gas may accumulate in the oven and explode.

land was covered with thick forests different from any growing now. Many trees then resembled gigantic ferns. Evidently these forests were flooded from time to time, the trees being overthrown and buried beneath sand washed in by the water. The flood subsiding, a new forest arose, to be in turn similarly buried. Pressure, combined with heat greater than now prevails anywhere on earth, slowly destroyed everything in these layers of plant-substance except the carbon, and left them as seams of coal.

Coal works for us. — The heat of burning coal may be utilized to cook food, melt iron, make steam to drive engines, and do hundreds of other kinds of work. A person able to work is said to have energy. Whence comes the energy of coal? From its carbon. But the carbon in the plants the coal was made from was stored up by the help of the sun. Plants obtain carbon from the carbon dioxide in the air. They can do this only in the light.

The heat of fires comes from the sun. — The sun, then, is the source of the energy in coal; we may say that the sun lights our fires. Stephenson, the inventor of the locomotive, when asked what drove his engine, answered, "Bottled-up sunshine." He spoke the exact truth; the sun's energy is stored up in coal-mines until, with pick and blasting powder, man sets it free.

Hard and soft coal; buying coal. — *Hard*, or *anthracite*, coal is the result of almost perfect carbonization of wood; in *soft*, or *bituminous*, coal the carbonizing has not gone so far.¹

¹ Wood contains about 50% of carbon, bituminous coal about 77%, anthracite about 90%. All coal contains sulphur. Charcoal is wood carbonized by burning it with just enough air to char it, but not consume it.

The latter is crumbly and dull, and burns with much smoke. Which yields the more heat; *i.e.*, has the more energy, hard or soft coal? Hard coal is best for household use, but as it is mined chiefly in the Atlantic states, in many parts of the country it is too expensive to be used. A good quality is jet black and glossy, breaks into roughly cube-shaped pieces, is free from slate, and yields little clinker. For a stove with a small fire-box, use *chestnut* coal; for most ranges a mixture of *stove* and chestnut is desirable. Too small coal will fall between the bars of the grate before being burned. It is prudent to buy a year's supply of coal in summer, when it is cheapest; coal bought by the pound or basket costs about three times as much as if bought by the ton.

How to save coal and gain heat. — Coal burns at first with a blue flame, but when thoroughly afire, with a clear, red glow. When white-hot, almost all its heat-giving power has been exhausted. A good coal fire consists of a mass of red coals covered by a layer of black ones heating and ready to kindle when the red ones die out. More heat is obtained from the same quantity of coal by adding it to the fire a little at a time than by putting it on all at once.

By the first method the coal gets sufficient air to be burned to carbon dioxide (CO_2); by the second, much of it is burned to carbon monoxide (CO). Thus it takes up only half as much oxygen as it is capable of uniting with, and so produces less heat.

Other fuels. — *Kerosene*, or *coal-oil*, prepared from the mineral oil petroleum, is the cheapest household fuel, and

is safe when it is of good quality and is burned in stoves intended for it. *Never use kerosene to kindle a wood or coal fire.* When heated, it gives off vapor that in contact with fire is likely to explode.

Natural gas, used for heating and lighting, flows from the ground. Both it and coal-oil are believed to be of vegetable origin. What is the source of their energy? Two kinds of gas are manufactured for lighting and heating purposes. *Coal-gas* is made by heating soft coal in a closed retort. *Water-gas* is made by passing steam over white-hot coke or anthracite coal.

A soft coal fire needs little draft below, but some on top to carry off the smoke and gas. It must be fed often and is hard to keep overnight. Some soft coal cokes as it burns. Break up the crust to keep the draft free.

Wood burns best with a wider grate than is needed for coal. It gives a quick heat, but more wood must be added often to keep the heat steady.

Distillate oil, used in the southwest where wood and coal are scarce, is a heavy coal-oil. The distillate burner fits into the fire-box of any range. It gives intense heat and is safe.

THE FIRELESS COOKER

A fireless cooker is a contrivance for completing the cooking of food by retaining in it the heat received from a short cooking over a fire. It consists of a box with a hinged lid, containing mineral wool or other non-conductor of heat packed so as to fit around one or more cooking utensils. Hay, sawdust, or crumpled newspaper is often used for packing

in home-made fireless cookers. The fireless cooker not only saves fuel, but saves time and trouble by making it possible to leave the food to cook without attention from morning till dinner-time or overnight. It is most satisfactory for foods which need long, slow cooking, which are not hurt by over-cooking, and which need not be crisp and brown, such as cereals, soups and stews, beans, boiled ham, and all dishes which may properly be steamed. Water can be kept hot in it. A fireless cooker is used most economically when gas or oil is used to start the cooking.

Directions for using fireless cooker. — The pail covers must fit tight and the pails must fit the nests. The pads, if used, must fill the space between the box-lid and the top of the pails. The pail should be nearly full of food. If the quantity is too small, put it into a pan or small cooking-utensil made for the purpose which fits into or over the rim of the pail; and cook some other food in the pail, or fill the pail with hot water. The pan must be tightly covered.

Have the cooker near the stove. Let the food begin to cook in the dish in which it is to go into the cooker. Liquids and foods in particles need only be brought to the boiling point. Foods in larger masses must be boiled from five to ten minutes to heat them through. Open the cooker before taking the food from the fire. Cover the dishes, after placing one inside another if necessary.

Put them quickly into the cooker, put on the pads, close and fasten the lid at once. Keep closed till food is to be served. If opened, the food must be re-heated to boiling and put back.



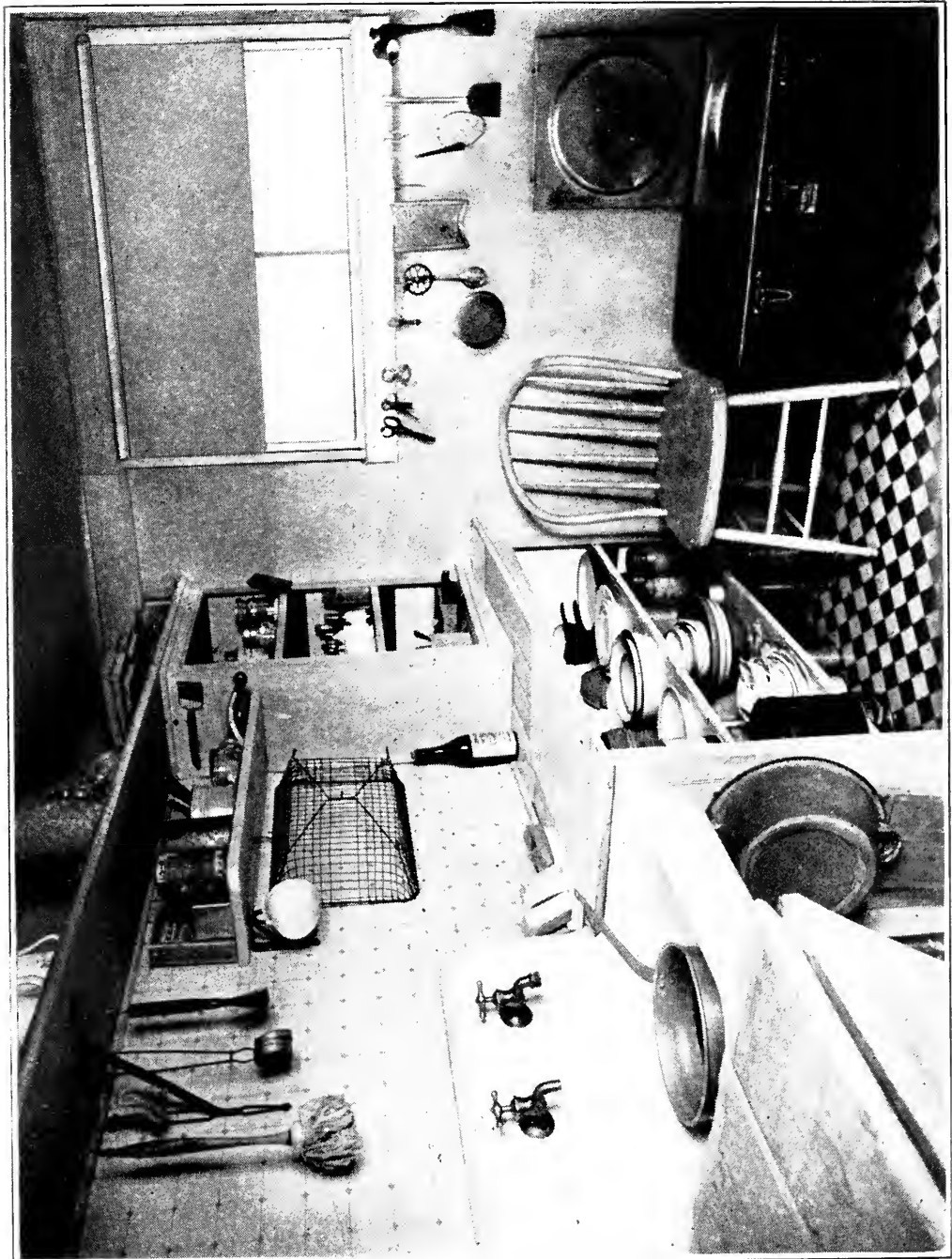

© Georgie Boynton Child.

A KITCHEN CORNER, SHOWING CONVENIENT SHELF-ARRANGEMENT AND FIRELESS COOKER.

Fireless cookers may be bought fitted with aluminum utensils and soapstone or metal plates to be heated and placed on and under the utensils. With these plates, food can be baked on a rack or roasted in a utensil.

A combination gas range and fireless cooker is now on the market. The oven is surrounded by non-conducting material so that after the food has begun to cook the gas may be turned off and the cooking completed in the oven without applying more heat. One of the top burners, set above a soapstone slab, has a hood which converts it into a second smaller fireless cooker.

Cooking by electricity is the most convenient of all methods, and the least wasteful of heat. With proper wiring there is no danger from fire. The current is either conveyed directly to each utensil or to a disk on which the utensil is placed. There is no fuel to be handled, no waste products to be removed. The heat is easily controlled. Electric toasters and chafing-dishes are seen upon many tables. But the apparatus, and in many places the current, is too expensive to be generally used. We may look forward, however, to the time when the cost shall be so reduced that cooking by electricity will be common.

BRIEF REFERENCE LIST

For further development of topics treated in this section see : —

SNELL: *Elementary household chemistry*. Ch. 9, 10, 11, and 12.

SNYDER: *Chemistry of plant and animal life*.

LASSAR-COHN: *Chemistry in daily life*. Lectures 1 and 2.

EARLE: *Home life in colonial days.* Ch. 3, The kitchen fireside.

KINNE AND COOLEY: *Foods and household management.* Ch. 3, Fuels and stoves.

MORGAN AND LYMAN: *Chemistry.*

GREEN: *Coal and the coal-mines.*

WHITE: *Fuels of the household.*

SECTION 2. WATER

Water in nature. — Water exists not only in the ocean and in other bodies of water, but in plants, in the bodies of men and animals, and even in rocks and other things that seem quite dry. Air contains water; some fruits consist of little but water and flavoring, with just enough solid matter to give them form; our bodies are about three-fifths water.

Water is called “the universal carrier.” It carries soil from place to place, piling in valleys what it washes away from hills; it bears seeds from one shore to plant them on another. It is the water in sap that enables it to flow through plants, carrying material to build them up; it is the water in blood that enables it to do the same for the animal body.

Water as a solvent. — A substance so mixed with a liquid that its particles cannot be seen and do not settle is dissolved, or in solution. Water dissolves more substances than any other liquid. To this property it owes much of its carrying power.

Experiments in solubility. — A. Put a level teaspoonful of salt into a glass of cold water. When the salt has disappeared taste the water. Put another teaspoonful into hot water. In which does the salt disappear more quickly? Try the same experiment with powdered chalk.

B. Find out which dissolves faster, a whole lump of sugar, or a lump broken into bits; coarse or fine salt.

C. Boil some of the salt solution till the water is all gone; taste the residue, and tell what it is.¹

Salt is soluble in water; chalk is insoluble in water. Hot water dissolves salt more quickly than cold water does; that is, it is a better solvent for it. The more finely divided a substance is the more rapidly it dissolves. Why?

Pure water; impurities, organic and inorganic. — Clean water is colorless, odorless, and nearly tasteless. Its slight taste comes from various substances dissolved in it. One of these is air. If a glass of water stands until the air in it appears in bubbles on the glass, it is found to taste "flat." Absolutely pure water has no taste. Such water is not found in nature. That most nearly pure is the rain-water that falls during the latter part of a shower. The first rain to fall carries down with it dust and other impurities from the air. As water flows over or soaks through the ground, it dissolves both organic matter of plant and animal origin and inorganic matter of mineral origin.

Living things, plants or animals, differ from lifeless things, in being able to feed, grow, and reproduce themselves. Organs were once supposed to be necessary for these acts; and, in consequence, things once part of an animal or a plant, as well as things actually alive, were termed *organic*. Though we now know that some tiny living things have no organs, we still use the words *organic* and *inorganic* to distinguish

¹ Sugar cannot be recovered from solution by boiling in the open air; it burns before it becomes solid. It may be recovered by crystallization, which we shall learn about in Chapter IX.

these two kinds of matter. Examples of inorganic matter : water, sand, carbon dioxide. Examples of organic matter : wood, perspiration, leaf-mold, manure.

Drinking water should be pure. — Much organic matter in drinking water makes it unwholesome, and may make it dangerous. Most objectionable of organic impurities is sewage, which is likely to contain disease germs. Wells are often dug for convenience near houses. Such a well may be polluted by house and stable waste. Rivers and lakes may be polluted by factory waste and sewage from towns. Neither such water nor ice cut from it is safe to use.

Spring water and water from artesian wells is usually pure. City water, if not from pure sources, should be filtered through sand beds. Filters of charcoal or porcelain for household use must be kept clean, or they soon become filled with impurities, making the water passed through them foul instead of purer. Small filters screwed on faucets remove sediment but not bacteria (p. 30). Drinking water about the purity of which there is any doubt should be boiled.

Hard and soft water. — Water is called *hard* or *soft* according to whether it contains much or little of the mineral *calcium* (lime). Neither dirt nor soap dissolves readily in hard water. Soap forms with it a curdy substance. Some hard water becomes soft if boiled. Boiling makes the calcium insoluble and it is deposited on the inside of the kettle. (See if there is such a deposit on the school-kitchen tea-kettle, or on your kettle at home.) Such water is called *temporarily hard* water. In *permanently*

hard water the calcium is in a different form. Boiling does not affect it. For cleaning and laundry purposes permanently hard water should be softened by the addition of washing soda or ammonia. A moderate degree of hardness does not injure water for drinking purposes. As a rule soft water is desirable for cooking, especially when the object is to draw out flavor or nourishment from food, as in making soup or tea.

A STUDY OF THE EFFECT OF HEAT ON WATER

Experiment. — Put some water in a saucepan or other vessel. Take its temperature with a thermometer. Set it on the stove or over a Bunsen burner, and hold the thermometer so that its bulb is below the surface of the water, but not touching the bottom of the vessel. (Fig. 2.) Watch the sides and bottom of the saucepan.

Are the bubbles large or small at first? after a little while? What comes off from the surface of the water? Note the temperature of the water. Note it again when the bubbles begin to break at the surface. Does the mercury rise after this? Increase the heat. Can you make the water any hotter?

Effect of heat on water, boiling-point of water. — When water

is heated the air dissolved in it expands, forming tiny bubbles. These rise, until the cold water near the surface chills them; then they contract, and sink again. When all the water has become warm they rise and escape. By this time the heat is beginning to change the water into

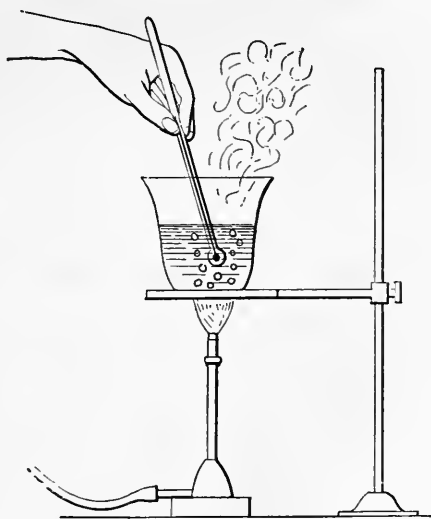

FIG. 2.

steam, an invisible gas.¹ The word *vapor* is applied to gases that under ordinary circumstances are liquid. Steam, therefore, is *water-vapor*.

Soon steam-bubbles appear. These are larger than air-bubbles. As they approach the surface of the water, they are cooled, and condensed; *i.e.*, turned back to water. This bubbling below the surface is called *simmering*.² The temperature of the water is now about 185° F. As the water grows hotter, some of the bubbles reach the surface and break there, giving off clouds of steam. Now, for the first time, the water boils. Its temperature is 212° F. By increasing the heat the water may be made to boil faster, but it will not grow hotter. All the heat is now being used in turning water into steam. If boiled long enough, all the water turns to steam and disappears in the air. If steam be cooled, by coming against a cover for instance, it gives up its heat and becomes water again.

The weight of air pressing on the surface of water prevents the steam from escaping until it gains force enough to overcome this pressure. At the sea level water boils at exactly 212°, but on a high mountain at a temperature several degrees lower. If the steam be confined, water may be raised above 212°; for the air under the lid soon takes up all

¹ Real steam is invisible, the mist we call steam being steam partially condensed. The slow forming of water-vapor that takes place at ordinary temperatures, in the drying of clothes, the disappearance of water after a rain, and the like, is called *evaporation*.

² In cooking, it is sometimes important to keep water simmering; at other times necessary to have it boiling. Learn to distinguish between these. When steam comes in jets from the spout of a teakettle, the water boils.

the vapor it can hold, making it impossible for any more water to be changed into steam. The heat that would otherwise be used in making steam is now saved and makes the water hotter. Steam under pressure may also be raised to a temperature higher than 212° F. Such steam is called superheated. Superheated steam is utilized in canning-processes. (P. 302.)

Effect of cold on water. — At 32° F. water freezes and becomes ice. At 32° ice melts and forms water. By heating ice, it may in a few minutes be changed to water and from water to steam. Do you know of anything else that is changed from solid to liquid and from liquid to gas, by heat?

Solids, liquids, and gases. — The particles of which a *solid* is composed hold firmly together; those of a *liquid* hold loosely; those of a *gas* tend always to go farther apart. Heat separates particles of matter; the loss of heat causes them to draw together again.¹ Hence we say, "Heat expands, cold contracts." Hot air rises, because by expanding it becomes thinner and lighter.

Composition of water. — Water is composed of hydrogen and oxygen. In what experiment was water formed? Where did the hydrogen come from? the oxygen?

SOME FACTS ABOUT WATER TO BE REMEMBERED

1. A solid dissolved in water will, in most cases, be found at the bottom of the vessel after the water has evaporated or boiled away.

¹ EXCEPTION. — Water expands just before it freezes; hence the bursting of pipes.

2. Boiling expels air from water, making it taste "flat." Boiled water should be poured back and forth several times from one pitcher to another, or shaken in a large bottle, to restore its flavor.

3. Temporarily hard water may be made soft by boiling.

4. Impure water may be made safe for use by boiling.

5. Since, by ordinary means, water cannot be made hotter after it begins to boil, fuel is wasted in keeping up more fire than is required just to keep the water at the boiling-point.

6. By covering the vessel some of the steam is condensed, and heat is saved.

Water in relation to health. — Drinking freely of pure water makes for health. The water we drink or take in as part of our food aids digestion, conveys nourishment to all parts of the body, removes waste, and in other ways keeps the body in order. Large quantities of cold water should not be drunk when one is overheated; nor should water or any other liquid be used to wash down half-chewed food.

But remember to take a drink of water several times a day.

Ice. — Good ice is clear and clean. Snow-ice looks white and melts too fast. Artificial ice is purest, because it is made from distilled water. The best way to cool drinking-water is to put ice around it, not in it.

BRIEF REFERENCE LIST

For further development of topics treated in this section see: —

MORGAN AND LYMAN: *Chemistry*. Pp. 66-74.

SNELL: *Elementary household chemistry*. Ch. 22, Hard water. Other scattered passages.

ELLIOTT: *Household hygiene*.

DODD: *Chemistry of the household*.

THORPE: *Dictionary of applied chemistry*. Ch. 5, p. 684.

BUCHANAN: *Household bacteriology*. Ch. 40, Water contamination.

CONN: *Bacteria, yeasts, and molds in the home*.

SECTION 3. CLEANLINESS AND CLEANING

Pure air and pure water we have seen to be simply clean air and clean water. The importance of cleanliness is better understood than ever before, now that scientists have shown the close relation between dirt and disease. The dirt that shows most plainly may not be the most objectionable. A dusty chair is of much less consequence than an unclean dish-cloth.

Two kinds of dust: lifeless and living. — The dirt in houses consists for the most part of dust, both alone and mixed with grease (fatty matter), moisture, and sticky substances. *Dust* is earth or other matter in particles so fine that it can be raised and carried by the wind. Dust is everywhere present. We see how quickly it gathers on the floor and the furniture; a sunbeam shows us that the air is full of it. This visible dust was for a long time the only kind known about. It has been discovered, however, that mixed with visible dust is another kind, so fine that it can be seen only with a microscope. This invisible dust is composed of tiny plants. When enough plants are growing together they can be seen with the naked eye.

Experiment. — Expose a piece of bread or cheese or some cooked fruit to the air for a few days, covering it to keep it moist. What appears on the surface?

Examine this growth with a magnifying-glass or microscope.

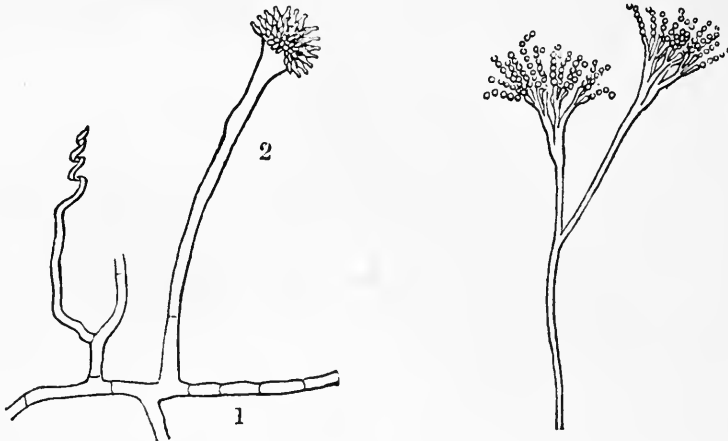

FIG. 3. — Two kinds of mold often found on food.

These microscopic plants are of three kinds, *molds*, *yeasts*, and *bacteria* (singular *bacterium*, rarely used). We shall learn more about yeast in Chapter IV (pp. 128–132).

Bacteria the most objectionable kind of dust. — Some kinds of bacteria, if they enter the body where conditions are favorable for their growth, may cause disease. Other kinds cause food to spoil. Bacteria thrive best in dark, damp, moderately warm places, where organic matter is present. Anything that kills bacteria or hinders their growth is called a *disinfectant*. We shall learn more about bacteria in Chapter III (pp. 97, 100) and in Chapter X (Sec. 1).

Light, air, and water natural cleansers. — Light promotes cleanliness by revealing dirt and destroying bacteria. Direct sunlight destroys bacteria. Wind may bring dust,

but a current of air removes smoke, foul air, and greasy or watery vapors, which combine with dust to deposit an unclean film. Water is the great cleanser, because it is the great solvent. Open windows and blinds and an abundant water-supply are "first aids" to cleanliness.

TOOLS AND MATERIALS FOR CLEANING

The necessary cleaning-tools for a kitchen, aside from those used for dishes and the sink, are broom, dust-pan and short broom, scrubbing-brush, floor-cloths and other cleaning cloths. Get a well-made broom, not too heavy. The dust-pan should have a strip across it in front of the handle to keep dust from flying back. Hemmed cheesecloth squares make the best dusters for general use. Coarse, loose-woven stuff is best for floor-cloths, soft cloths for paint. The scrubbing-brush should be of a size and shape to be easily grasped by the hand that is to wield it.

Labor-savers. — A dust-mop is convenient. "Dustless" mops and dusters are treated with a chemical which makes dust cling to them instead of flying about. Avoid wet mopping if possible. A wet mop is hard to dry and to keep clean. A long-handled dust-pan saves stooping. The housewife or houseworker should have labor-saving tools as well as the farmer, the mechanic, or the business man. A vacuum cleaner does the work of brushes, brooms, and cloths, and does it better, because it draws out and sucks up dust, scraps, and loose stuff. Although of especial value in rooms containing draperies, stuffed furniture, and carpets, its service is desirable in a kitchen, where dust should not be raised.

Friction. Abrasives. — Brushes and cloths produce friction, which is necessary for removing spots and dirt that sticks or is ingrained. Powdered minerals, such as whiting, bath brick, rottenstone, sand, and various silicious materials, increase friction and in some cases give polish.

CHEMICAL CLEANSERS

Soap. How it cleans. — It is often hard to clean and polish by main force, with the aid of water, tools, and abrasives only. What do we depend upon to “start the dirt”? Soap. And why does soap clean so easily and quickly? because it acts *chemically*. Water decomposes soap, setting alkali free. Alkali decomposes the grease which is usually mingled with dirt, and so loosens the dirt. It forms with grease a compound soluble in water. Soapsuds emulsifies grease; that is, it holds it suspended in particles. Soap may also act chemically in other ways on some kinds of dirt.

Soap is made out of fat or oil and an alkali (pp. 57, 108). The alkali used in soap-factories is a soda compound. In a well-made soap, no fat nor alkali is left uncombined. An excess of alkali injures paint, fabrics, and the skin. All soaps contain water. Some cheap soaps contain so much water that it does not pay to buy them. Others are adulterated with material that weighs, but does not clean. White soaps are usually pure. Floating soap is made light by having air beaten into it while it is hot and soft. Such soap dissolves faster than heavier soaps. Fresh soap also dissolves fast, because it is moist. It is well to unwrap it and pile it loosely to dry. (For laundry-soaps, see p. 360.)

Alkalies. — Three alkalies, sal-soda, commonly called washing soda, borax, and ammonia, are used in cleaning. Washing soda is the strongest of these. It comes in crystals, but it is better to use a solution. Dissolve one pound of washing soda in one quart of water in a saucepan over the fire. When it is cool, put it in a bottle and label it sal-soda solution. Do not let it touch the hands. It will make the skin sore. When needed, pour a little into the water to be used for washing or cleaning.

Scouring soaps. — Soap powders consist of washing soda and powdered soap. They may contain much water, and in general are not worth their price. Sand-soap is what its name implies, a mixture of soap and fine sand. It is less used than formerly. Modern scouring soaps and powders contain some gritty mineral and soap. Some contain sal-soda also.

Petroleum cleansers. — Kerosene, gasoline, naphtha, benzine, all products of petroleum, are valuable cleansers. Kerosene is especially useful for cleaning things which alkalies would injure, for example, polished wood. The other three dissolve grease, but are dangerously explosive, and as a rule unsafe to use indoors.

Disinfectants. — Soap, alkalies, and kerosene are all good disinfectants. A more powerful disinfectant, not a cleanser, is chloride of lime.

CLEANING METALS

Experiments. — A. Let a piece of iron lie wet in the air for several hours. Pour a little water into an old worn tin dish; allow a few drops of water to fall on a steel knife-blade; and let dish and knife lie for some

time. What do you observe? Has the *tin* rusted? How can we keep steel from rusting?

B. Lay one silver spoon next to a rubber band. Wrap another in white flannel. Lay a bright brass button in a dry place. Wrap another in damp cloth. Examine all these after a day or two. Would you approve of keeping silver wrapped in white flannel? What effect has dampness on brass?

Rust and tarnish. — *Rust* is a compound, formed in the presence of moisture, by the union of the oxygen of the air with iron or steel. Rust scales off, and more forms. Thus the metal is eaten away. Rust must be prevented. To do this, keep steel utensils polished, iron ones dry and smooth. *Tarnish* is a discoloration of polished metals caused by the action of oxygen, sulphur, or some other element upon the metal. The sulphur used in making rubber and in bleaching cloth, and the sulphurous gases from burning coal or gas, form with silver a grayish black compound insoluble in water.

C. Try to remove the tarnish from silver with whiting, with alcohol; from brass with rottenstone, with rottenstone and water, with rottenstone and oil, with vinegar or lemon-juice. Compare the effectiveness of the various materials.

Removal of tarnish. — Acids act chemically on tarnish, dissolving it. Oxalic acid, lemon-juice, and vinegar may be used. But, except for spots, it is best to rely mostly upon powders in cleaning metals. A chemical that removes the tarnish may attack the metal. For example, any chemical that brightens zinc, eats into it. If acid is used on any metal, all traces of it must be removed by rubbing with powder, or the tarnish will quickly reappear. Oil or water, mixed

with the powder, forms a paste easy to apply. Use chamois-skin or soft cloth for polishing.

CARE OF FLOOR AND WOODWORK

Care of kitchen floor. — A linoleum-covered floor is the most easily kept clean. Next best is a hard-wood floor. Wipe or brush up at once anything spilled. Cover grease-spots on wood or stone with flour, starch, or powdered chalk, which will absorb the grease. Cold water poured upon grease as soon as it is spilled will harden it; the greater part may then be scraped off. Sweep the kitchen floor thoroughly once a day. With care it will not need washing or scrubbing oftener than once a week.

How to sweep. — Before beginning to sweep, see that no food is left uncovered in the room. Sweep from the edge of the room toward the centre. Sweep with short strokes, keeping the broom close to the floor. Turn it edgewise to clean cracks. When the dust has been gathered at one spot, take it up with a short broom and a dust-pan, and, if possible, burn it at once. Never sweep dust from one room into another. Always sweep a floor before washing or scrubbing it.

How to scrub a floor. — Soft-wood floors must be scrubbed. Provide two pails of cold or lukewarm water; a stiff scrubbing-brush; a large, soft, but not linty cloth; and sapolio or any good scouring soap. Dip the brush in water, then rub it over the sapolio. Look for grease-spots and take them out first. After the floor has become wet you cannot see where they are. Scrub with the grain of the wood, doing

a few square feet at a time. Dip the cloth in clean water, and wash the part that has been scrubbed. Use no more water than you need. Wet the cloth again, wring it as dry as you can, and wipe the floor. Proceed in this way until the whole floor has been cleaned.

Care of hard-wood floor. — On a hard-wood floor use little water or none at all. Wipe it with a cloth moistened with a very little kerosene, — a teaspoonful or two to begin with, and as much more when that has evaporated. Rub hard with another cloth until the wood is perfectly dry. Window-sills and all hard-wood finish may be cleaned in the same way.

Care of oil-cloth. — Wash oil-cloth with warm water and milk, — one cupful of skim-milk to one gallon of water, — and wipe dry with clean cloth.

Cleaning paint. — To clean paint, provide whiting, two basins or pails of water, and three clean, soft cloths, — woollen is best. Take a little whiting on a damp cloth, and rub it on the surface to be cleaned. Do not let drops of water trickle down the paint. Wash off with a second cloth and clean water. Wipe dry with a third cloth. Clean a little at a time, leaving the cleaned part dry before going on.

Dusting. — After sweeping a room dust the woodwork, furniture, and movable articles with a soft cotton cloth. Spread the cloth out and gather the dust into it, folding it in as you work. Shake it frequently out of the window. In the kitchen where there are no delicate articles to be injured by moisture, use a damp cloth. To have it just damp





KITCHENETTE WITH GAS-RANGE.

© George Boynton Child.

Observe the roll of paper towelling, rack for draining dishes, match-boxes attached to stove, and a number of utensils within easy reach.

enough, wet a part of it, wring this out, fold the damp part and the dry together, and squeeze them. When the room has been dusted, wash the cloth and hang it to dry.

THE SINK AND ITS FITTINGS

Construction of the sink; the trap. — Porcelain and enamelled iron are the best materials for a sink. Wood is least desirable, because hardest to keep clean. The space below the sink should be left open. The sink should slope down toward the waste-pipe. The waste-pipe should have a bend in it that will allow water to stand in it deep enough to prevent gases from passing up from the drain into the kitchen. This bend is called a *trap*. The water it contains is called a *water-seal*. (See Fig. 4, p. 38.)

After pouring soiled water down the waste-pipe, follow it with clean water, so that foul water shall not stand in the trap. If a sink is left unused for several days or longer, the water-seal may evaporate so that gases from the drain rise into the room. On this account a house that has been vacant should be well aired before being occupied.

Sink-fixtures and conveniences. — There should be a strainer, screwed down over the top of the waste-pipe. It is well to have a finer strainer also, through which to pour waste-water. This, by catching crumbs which might pass through the set strainer, helps to keep the sink clean. A grooved draining-board, sloped toward the sink, and a shelf above the sink for cleaning materials, are convenient. There should be hooks for hand-basin, dipper, soap-saver, sink-scraper, and scrubbing-brush. The garbage-pail should

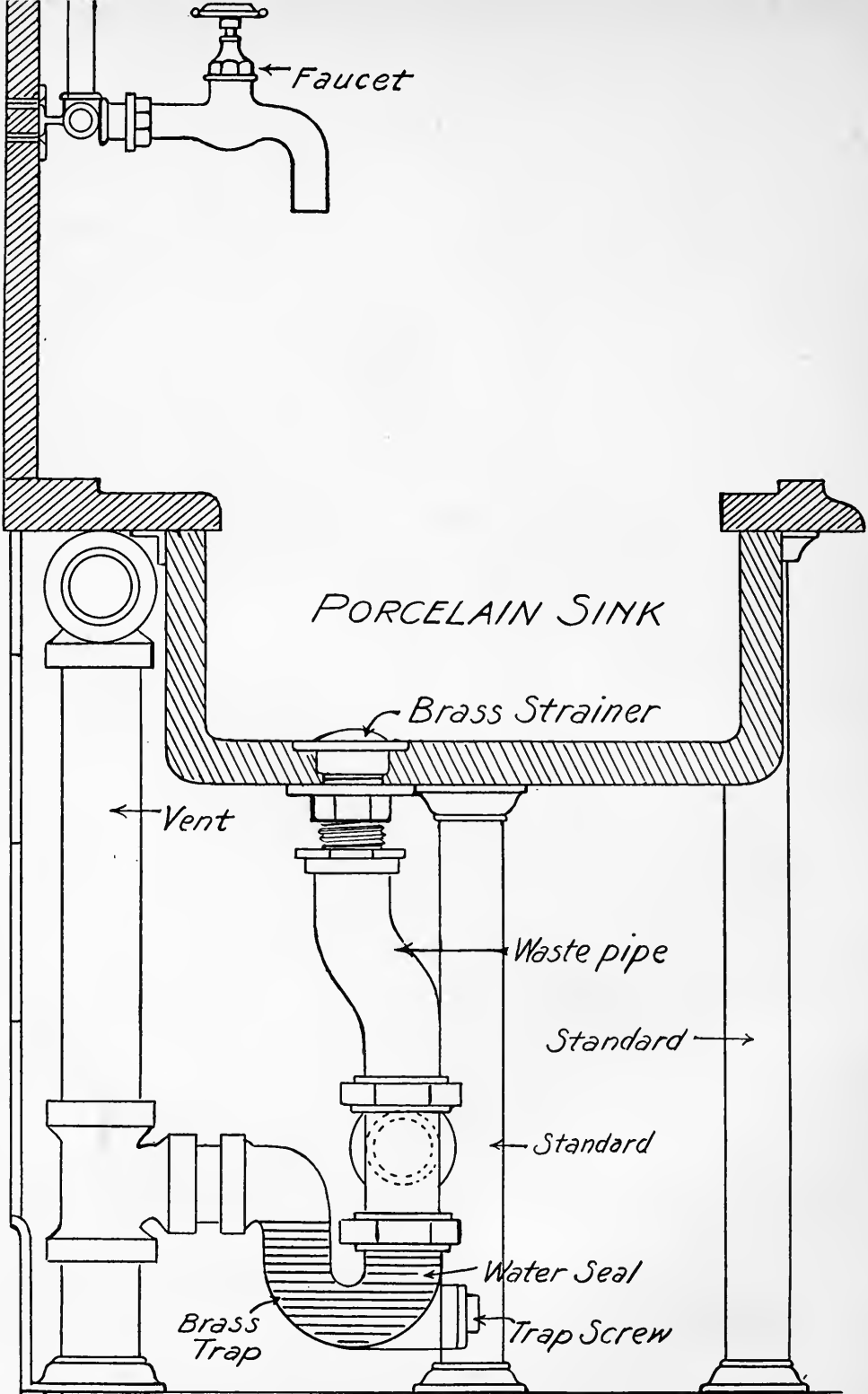

FIG. 4.

be of metal, or other non-absorbent material. Its cover should fit tightly.

Care of the sink.—Neglect of the sink causes bad odors and attracts water-bugs and roaches. Keep it at all times free from scraps. When the dishes have been washed, or when the sink is to be left unused for several hours, wash it, using scrubbing-brush and sapolio. Wipe the woodwork and tiling. Wash strainer, soap-dish, and other sink utensils. Wash the cloth. Scrub the draining-board, and rinse the sink. If it is of iron, and is to be left for several hours, wipe it dry. If rusty, use kerosene, or grease it with mutton-fat or lard, sprinkle with lime, and leave overnight.

Care of faucets.—Clean brass faucets with flannel dipped in vinegar or lemon-juice, and rub thoroughly with rottenstone and oil, then polish with a dry cloth; or apply putz pomade or some similar preparation, rub off with another cloth, and polish with a third one. If the faucets are greasy, wash them with soap-suds or sal-soda solution before using anything else. Nickel faucets and trimmings need only to be washed with hot soap-suds and wiped dry.

Care of waste-pipe and trap.—Waste-pipe and trap must be kept as free as possible from deposits of grease. After pouring down very greasy water pour down boiling water so that the grease may not cool and settle on the sides of the waste-pipe.

Care of garbage-pail.¹—Scrub the garbage-pail with

¹ It is better to avoid using a garbage-pail. Garbage may be burned in a bright fire if all the drafts are left open. A garbage-incinerator built into the stove-pipe or chimney is desirable.

sal-soda and rinse with boiling water once a day. Dry it in the sunshine, if possible. Where there is no objection to mixing paper with garbage, the pail may be kept clean by lining it with newspaper.

CARE OF DISHES

Dish-washing need not be an unpleasant task if these rules are observed: 1. Use hot soapy water. 2. Change the water frequently. 3. Have the dishes free from crumbs and scraps before beginning to wash them.

Directions for dish-washing. Preparation. — Collect all dishes to be washed. To save time and steps in clearing off, use a tray to carry dishes from table to sink. Some people, by taking only what they can carry in their hands, make ten trips where two would do. If you can afford it, have a butler's tray (Frontispiece). As you take the dishes from the table, scrape and stack them on the tray. Wheel it to the sink and remove the dishes from it directly to the dishpan. A table on casters will do instead of the tray. Scrape them, putting scraps in an earthenware or enamelled dish; wipe frying-pans and other greasy dishes with pieces of soft paper. This paper may be used for kindling. Or fill them with hot water to which a teaspoonful of sal-soda has been added, and let them stand. Soak dishes that have contained batter, dough, eggs, or any starchy material in cold water; dishes that have been used to cook sugar, in hot water. Put all dishes of a kind together; plates in piles, knives, forks, and spoons laid with handles one way, etc. Place nearest to you the dishes to be washed first.

Have a clean dry place clear for clean dishes. Make ready two pans, or one if there is a draining-board.

Washing. — Wash the dishes in the following order: 1, Glassware; 2, silver; 3, cups and saucers; 4, plates; 5, larger dishes; 6, the cleaner articles of kitchenware; 7, large utensils. This order may be varied according to circumstances. If you have hot water at hand constantly, the kitchen utensils may be washed and put away first, or as fast as they are used.

General instructions. — Wash all dishes, inside and out, in soapy water; rinse in clear hot water, drain, and wipe dry. Use sapolio or cleaning powder to remove food that sticks or is burnt on. Use a wire dish-cloth on ironware, a scrubbing-brush, if necessary, on enamelled ware, tinware, and wire strainers. Clean seams in tinware and enamelled ware with a wooden skewer.

Special instructions. — Do not put knife-handles in water. Water discolors and cracks ivory and bone handles, and may loosen wooden ones. After washing knives, scour them with bath brick. Do not wash bread-board or rolling-pin at an iron sink. The iron will leave marks on them. Wash them at the table. Be careful not to wet the cogs of a Dover egg-beater. Wash the lower part, and wipe off the handle with a damp cloth. Water washes the oil from the cogs, thus making the beater hard to turn. Dry the seams of a double-boiler carefully. Do not waste time polishing tins. It is sufficient to have them clean and dry.

Dip glasses into hot water, so that they will be wet

inside and outside at the same time. Unequal expansion of the glass, caused by one part's being heated suddenly, is what breaks them. Silver and glass are brightest if wiped directly from clean, hot suds, without being rinsed. A damp towel makes dull spoons and glasses. Scald; *i.e.*, rinse with boiling water all vessels that have contained milk. Wash teapot and coffee-pot in clean hot water without soap, and wipe dry. Clean the spout carefully. Let them stand for a while with covers off. Wash dish-pan and rinsing-pan, and wipe dry with a towel, not with the dish-cloth.

Where running hot water is plentiful, time and towels can be saved by placing the dishes as they are washed in a wire rack, rinsing them with very hot water, and letting them drain. It is best, if possible, to set the rack of dishes for a minute into a pan or sink full of scalding hot water. Wipe glasses and silver. China and other ware will need only a polish with towel or strip of paper towelling. For success with this method, the dishes must be washed in clean hot suds, and rinsed quickly. If washed in greasy water, or allowed to cool before being rinsed, they will not dry clean. Caution: gold-decorated china should not be washed in this way. Very hot water may injure it.

For care of towels and sink, see pp. 39 and 44.

To scour steel knives. — Scrape off a little bath brick with the back of the knife or with an old knife. Dip a cork in water or oil, and then in the brick-dust. Hold the knife firmly, with the blade resting flat upon a level surface, and rub both sides of the blade with the cork. (Fig. 5.) Wash

the knife. Scour steel forks in the same way. Never scour silver-plated knives or forks.

Care of aluminum ware. — Aluminum should not be used for vegetables with strong acid or for boiling eggs. These discolor it. Otherwise it needs little care. Never use soda on aluminum. Before using any polish fill with water and bring to a boil. For bad stains use oxalic acid diluted, one teaspoonful

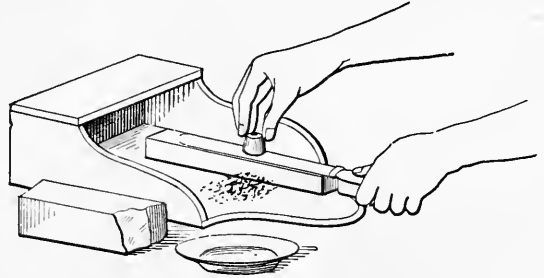

FIG. 5.

of acid to two quarts of water. If the stain still remains, rub with a damp cloth dipped in whiting or Dutch cleanser.

To clean silverware. — The quickest way to brighten silver is by electrolysis, that is, by decomposing the tarnish by electricity. One device for this purpose is an aluminum pan with cross-bars of tin on the bottom. Fill the pan with water, and for every quart dissolve in it one teaspoonful of baking-soda and one tablespoonful of salt. The silver must rest on the bars and be covered with the solution. A mild current of electricity is set up which causes the tarnish quickly to disappear. No rubbing is needed, but embossed silver may need brushing to loosen the tarnish. Rinse in clear water, and wipe dry with a soft cloth. The old way is to moisten a soft cloth with water or alcohol, dip it in fine whiting, and apply to the silver. When the whiting has dried, rub it off with another soft cloth, and polish with chamois-skin. To cleanse chasing or orna-

mental work, use an old tooth-brush. Rub egg-stained spoons and other badly tarnished articles with salt before washing them. The tarnish is not soluble, but with the chlorine in the salt it forms a soluble compound (pp. 22 and 57). Powders or cakes sold by silversmiths are good. Patent powders and polishes often remove some of the silver.

CARE OF KITCHEN TOWELS AND CLOTHS

Dish-cloths, dish-towels, and sink-cloths should be hemmed. Lint and threads from unhemmed cloths are likely to obstruct the sink drain. Use each cloth only for the purpose for which it is intended.

The dish-cloth. — Keep the dish-cloth clean. It is disagreeable to think of eating from dishes washed with a sticky, greasy cloth. Such a cloth harbors germ and may spread disease. Wash the dish-cloth with hot water and soap after using it. Rinse, shake it out, and hang it to dry, — in the sun, if possible. Boil it once a week, or whenever washing fails to make it white. Never use it for anything except washing dishes.

Other cloths. — Wash dish-towels often in warm water, using soap. Rinse them in warm or cold water, and hang them to dry with the ends pulled evenly together. Strainer-cloths that are not greasy may be washed in cold water. Wash greasy ones in hot water with soap or sal-soda. To remove fruit stains from a cloth, lay it over a bowl and pour boiling water upon the stain. All cleaning-cloths should be washed, rinsed, and dried after being used. Throw very dirty ones away.

CARE OF STOVE AND ZINC

If anything is spilled on the stove or range, wipe it off at once with soft paper. Use sapolio to remove anything not taken off by the paper. To keep it black and clean, wipe it daily with a few drops of kerosene on a cloth. Polishing is unnecessary; but if you prefer to polish it, apply stove-blackening just after the fire has been started, and polish with a brush or coarse cloth. A new type of gas-range is enamelled, a finish which makes it much easier to keep clean.

Zinc discolors easily. Even a drop of water allowed to stand on it will make a spot. It may be cleaned with a little kerosene rubbed on with a flannel, or with electro-silicon on a damp cloth. Polish with dry flannel.

CARE OF REFRIGERATOR

The waste-pipe of the refrigerator or ice-box should empty into a pan, or into the open end of a properly trapped drain-pipe.

Daily care. — Keep the inside of the food chamber dry. See that no food remains in the refrigerator long enough to spoil. Empty the pan, if there is one, every day. If there is a catch-basin, keep it free from dust and slime.

Weekly cleaning. — Clean the refrigerator thoroughly at least once a week. Take out both food and ice. Wash shelves and racks with hot soapsuds or with sal-soda solution, and rinse with clear hot water. Dry them in the open air or by the fire. Wash the food chamber and the air chamber in the same way. Clean grooves and corners

with a skewer, and run a wire with a cloth twisted around it down the waste-pipe. Rinse the pipe with hot sal-soda solution. Wipe the refrigerator dry; and, if possible, let it remain open for an hour.

CARE OF ARTICLES USED IN CLEANING

Rinse scrubbing-brushes and dry them in the sun, bristles down. Hang up brooms, when not in use, by screw-eyes or strings tied into the handles. Wash dusters often. Do not waste soap by leaving it in water. Keep knife-cleaning materials in one box, silver-polishing materials in another, etc. See that all things used in cleaning are kept clean.

Insects. — Protect food from flies. Flies come from dirty places and may carry germs of typhoid fever or other diseases on their feet. To keep flies, ants, cockroaches, and water-bugs away, keep the kitchen clean and dry, keep food and garbage covered, and leave no scraps or crumbs about. For ways of ridding a kitchen of insects, see books of reference named on page 48.

PERSONAL CLEANLINESS

Observe the following rules in both the school kitchen and the home kitchen: —

1. When cooking, or doing other housework, wear a washable gown short enough to clear the floor by at least two inches.

2. When in the kitchen, pin or tie your hair back so that no hairs may fall into the food. When sweeping, cover it with a cap or kerchief to protect it from dust.

3. Wear no rings nor bracelets in the kitchen.

4. Before touching or preparing any food, wash your hands thoroughly with soap and water; scrub the nails with a nail brush, and clean them with a wooden toothpick or a regular nail cleaner.

5. Keep a damp towel at hand, on which to wipe your fingers if they become soiled or sticky. Always wipe them after touching your hair or pocket handkerchief, or after handling the coal-hod, or anything else not quite clean. Never wipe them on your apron, your handkerchief, or on a dish-towel.

6. Never dry dishes with a hand-towel.

7. The best way to taste of what you are cooking is to take a little of the food up with the mixing-spoon, put it in a teaspoon, and taste from the teaspoon. If you should happen to taste from the mixing-spoon, wash it before putting it back into the dish.

BRIEF REFERENCE LIST

For further development of topics treated in this section see: —

KINNE AND COOLEY: *Foods and household management*. Ch. 2, and ch. 22, Dust.

ELLIOTT: *Household bacteriology*. Pp. 1-39. Sanitation, pp. 96-108.

ELLIOTT: *Household hygiene*.

ABEL: *The care of food in the home*. *Farmers' Bulletin* 375.

BUCHANAN: *Household bacteriology.*

CONN: *Bacteria, yeasts and molds in the home.*

RICHARDS: *Sanitation in daily life.*

RICHARDS AND ELLIOTT: *The chemistry of cooking and cleaning.*

U. S. DEPT. OF AGRICULTURE: DIVISION OF ENTOMOLOGY. *Circulars:*
13. Mosquitoes and flies; 34. House ants; 35. House flies; 51. Cock-
roaches; also other circulars about other insect pests.

HEALTH EDUCATION LEAGUE: Booklet 4. *The plague of mosquitoes and flies.*

DOANE: *Insects and disease.* Illustrations and bibliography.

PARLOA: *Home economics.*

SECTION 4. DEFINITIONS, TABLES, RULES

Food and cooking; how and why food is cooked.—

Food is whatever nourishes the body. Cooking is making food ready to eat. This is done chiefly by means of heat.

Food is exposed to the action of heat, (1) to make it more digestible, (2) to improve its flavor, (3) to kill any living things it may contain, and (4) to improve its appearance.

Many vegetable foods and a few animal foods, oysters for instance, may be eaten uncooked.

PRINCIPAL METHODS OF COOKING

- | | |
|--|---|
| 1. <i>Broiling</i> : cooking over a glowing fire. | } Direct appli-
cation of
heat. |
| 2. <i>Roasting (toasting)</i> : cooking before a glowing fire. | |
| 3. <i>Baking</i> : cooking in an oven. | } Application
by means of
heated air. |

TABLE COMPARING WEIGHTS AND MEASURES

2 cupfuls of butter (packed solidly)	=	} 1 pound
2 cupfuls of finely chopped meat (packed solidly)	=	
2 cupfuls of granulated sugar	=	
$2\frac{2}{3}$ cupfuls of powdered sugar	=	
$2\frac{2}{3}$ cupfuls of brown sugar	=	
$2\frac{2}{3}$ cupfuls of oatmeal	=	
$4\frac{3}{4}$ cupfuls of rolled oats	=	
4 cupfuls of flour (about)	=	
9 or 10 eggs	=	
2 tablespoonfuls of butter	=	} 1 ounce
4 tablespoonfuls of flour	=	
2 tablespoonfuls of cocoa	=	

DIRECTIONS FOR MEASURING

1. Sift, or shake up lightly with a spoon, all dry materials (flour, baking-powder, etc.) before measuring them. Always *sift* mustard.

2. All measures are to be taken *level* unless otherwise directed.¹

3. To measure a cupful of dry material, fill the cup with a spoon or scoop, and level off with a case-knife. To measure a teaspoonful or tablespoonful of dry material, fill the spoon by dipping it into the material, lift it, and level off with a case-knife. To measure a half-spoonful, divide a spoon lengthwise with the knife. Divide a half-spoonful crosswise to measure a quarter, and a quarter-spoonful crosswise to measure an eighth. Less than an eighth of a teaspoonful is called "a few grains."

¹ In some cookbooks, including all published before 1896, it is intended that spoonfuls of flour, baking-powder, sugar, butter, and lard should be measured rounded. One rounded spoonful is equal to two level spoonfuls.

PLATE IV.

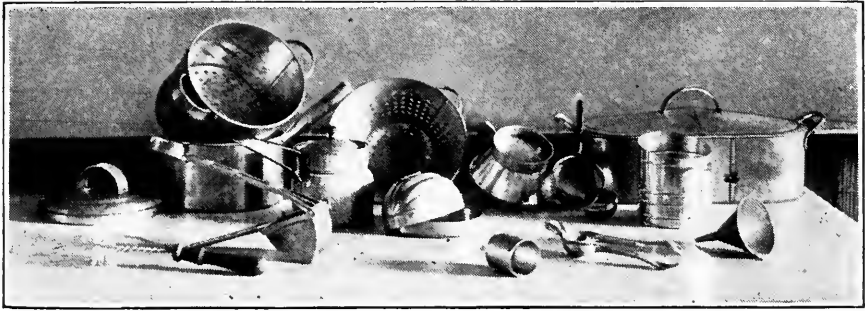

Steamer	Colander	Strainers	Fish-boiler
Double boiler	Melon-mold	Flour-sifter	Funnel
Vegetable press	(for puddings, ice cream, etc.)	Lemon-squeezer	
Potato-masher	Biscuit-cutter		

COOKING UTENSILS.



One cupful of sugar weighing one-half pound	Measuring one cupful of dry material
Quart-measure	
Half-pint measuring-cup	
One-half teaspoonful, measured	One-fourth tablespoonful, measured

MEASURING.



4. A cupful of liquid is all the cup will hold ; a spoonful of liquid is all the spoon will hold. A *heaping* spoonful of *dry* material is all the spoon will hold. A scant cupful is measured by filling the cup to within one-eighth of an inch of the brim.

NOTE. — Success in cooking depends greatly upon accuracy in measuring. Only after much practice in measuring as here directed, should you venture to measure even small quantities by your eye. The requirement of accurate measuring and the giving of exact quantities of material in the recipes in this book, are not intended, however, to do away with the exercise of individual taste and judgment. So long as flours vary in thickening quality, and spices and other cooking materials in strength, it will be impossible to write recipes that can be followed absolutely in all cases. Follow a recipe exactly the first time you use it ; if it requires to be varied, you can then make the change intelligently ; but if you have not followed it exactly, you cannot be sure which is at fault, the recipe or the cook.

The quantities of seasonings given in this book are, as a rule, the smallest desirable. Increase them cautiously to suit your taste ; but do not fall into the error, common in America, of overseasoning food with pepper and salt.

NOTE TO TEACHER. — In dividing recipes to make individual recipes for practice-work, allow more liquid proportionately than the whole recipe calls for. More proportionately of a small quantity of liquid will cling to cup or spoon, and more will be lost by evaporation in cooking.

One egg beaten usually makes about one-fourth of a cupful. If you are dividing by eight a recipe which calls for one egg, use two teaspoonfuls of beaten egg in the individual recipe.

In individual recipes use baking-powder in the proportion of two teaspoonfuls to one cupful of flour.

INDIVIDUAL RECIPE FOR STANDARD CAKE (p. 277)

Butter, $\frac{1}{2}$ tb.

Flour, 3 tb.

Sugar, 2 tb.

Baking-powder, $\frac{1}{4}$ t.

Beaten egg, 1 tb.

Vanilla, 4 drops

Milk, 1 tb.

Salt, f. g.

TABLE OF ABBREVIATIONS USED IN THIS BOOK

tb.	stands for tablespoonful, or tablespoonfuls.
t.	stands for teaspoonful, or teaspoonfuls.
c.	stands for cupful, or cupfuls.
qt.	stands for quart.
pt.	stands for pint.
lb.	stands for pound.
oz.	stands for ounce.
f.g.	stands for a few grains.
r.	stands for rounded.

In some books T. or tbsp. stands for tablespoonful, and tsp. for teaspoonful.

hp.	stands for heaping.
sc.	stands for scant.
min.	stands for minute, or minutes.
hr.	stands for hour.

Hints on how to work. — 1. See that the fire is ready for use, or so arranged that it will be ready by the time it is needed.

2. Collect all the materials that will be needed.

3. Collect all the dishes, spoons, and other utensils that will be needed, including a plate on which to lay sticky spoons, knives, etc.

4. Take care not to make work for yourself by using more utensils than are necessary. For instance, by measuring dry materials first, then liquids, and last, fats, you need use only one cup.

5. When milk and eggs are used, save a little of the milk to rinse out the bowl in which the eggs are beaten.

6. Use an earthen bowl for mixing cakes, muffins, etc.

A tin dish and an iron spoon are likely to discolor the mixture.

7. Have all materials ready for use (flour sifted and measured, eggs broken, raisins stoned, etc.), before beginning to put them together.

8. Cover flour-barrel, sugar-bucket, baking-powder can, etc., as soon as you have taken from them what you need.

9. Clear up as you work, putting dishes to soak as soon as they are emptied, and washing them at once if you have a moment to spare.

10. When you have finished, collect all the dishes that remain, saving any unused material that is in good condition.

11. Learn to work neatly, carefully, quietly, and quickly.

PURE FOODS AND HONEST WEIGHTS AND MEASURES

Pure food means honest food. It would not be honest to can spoiled fruit, to mix cracker crumbs or sawdust with spice, to substitute a cheaper oil such as cottonseed for olive-oil, or to color or bleach food with poisonous chemicals. Such practices are examples of *food adulteration*. *Misbranding* food is putting labels on it which are intended to deceive the purchaser. "Pure food laws" prohibit adulteration and misbranding. Each state should have strict laws of this kind, as the Federal laws do not apply to foods prepared and sold in the same state.

One should know what is a reasonable price for each kind of goods and be suspicious of anything much cheaper. One may rightly buy the cheaper of two similar foods if it is

wholesome and sold for what it really is. But food of poor quality will not do the work of good food in the body. True thrift is to buy reliable food and to waste none of it by careless handling or poor cooking.

In buying supplies, see that you get the quantity you pay for. Some tradesmen are dishonest. Others may be careless. Some, particularly pedlers and small dealers who undersell others, use false weights and measures: scales that weigh less than they appear to, "quart measures" holding less than a quart, cans and baskets with false bottoms. Buy everything by a standard measure, such as a pound, a quart, or a bushel. The terms "pailful," "handful," or "ten cents' worth," mean nothing in law. But the dealer who sells less than a pound for a pound, or less than a bushel for a bushel may be arrested and punished.

See that the dealer does not touch the scales or the food while it is being weighed. Do not let him weigh a wooden dish with lard or butter, or a heavy paper or bag with anything you buy unless he allows for its weight. It pays to have accurate scales and a set of accurate dry and liquid measures in the kitchen with which to re-weigh your purchases.

BRIEF REFERENCE LIST

For further development of topics treated in this section see:—

PARLOA: *Home economics*.

HOUSEKEEPING EXPERIMENT STATION: *Bulletins*. Particularly 5 and 12.

BARROWS: *Principles of cookery*.

MAYOR'S BUREAU OF WEIGHTS AND MEASURES, N. Y. CITY: *What the purchasing public should know.*

U. S. DEPT. OF AGRICULTURE: BUREAU OF CHEMISTRY. *Publications relating to the inspection and analysis of food.*

SHERMAN: *Food products.* For information about adulteration, pure food laws, etc.

FARMER: *Boston cooking school cook-book.* For time-tables, methods of working, and cooking-utensils.

SECTION 5. HOUSEHOLD CHEMISTRY

Physical and chemical changes. — How many changes take place every day in common things !

The burning candle changes from an opaque white solid to a translucent liquid, and then to a mixture of invisible gases. Salt, upon being mixed with water, becomes a clear liquid not distinguishable from water itself. The solid carbon of wood and the gas oxygen unite to form carbon dioxide, a gas quite different from oxygen; and when the action is over, a handful of gray ashes is all the solid substance left. Heat readily changes ice to water, and water to steam.

We are so used to these happenings that they excite in us no wonder; yet, for hundreds of years men have been studying these and similar changes, without finding out all there is to be known about them. So important is the part they play in our everyday work, especially in cooking, that a knowledge of the simpler facts about them is a great help to housekeepers.

These changes are of two kinds. Liquid candle grease returns to the solid form when cooled; dissolved salt may be recovered by evaporating the water; even steam may be collected, condensed, and frozen. No new substance has been formed. The change which has taken place is a *physical* change. When, however, melted candle grease be-

comes gaseous, it will not return to its original form ; burnt sugar will never be sweet and white again ; water acted upon by sodium is neither water, steam, nor ice. New substances have been formed. In each case a chemical change has taken place. Heat, especially in the presence of moisture, often brings about chemical changes.

Elements and compounds. — Some substances are simple ; that is, they consist of but one thing. Examples : iron, oxygen, carbon. A simple substance is an element. Other substances are composed of two or more elements. Examples : water, carbon dioxide. Into what elements may water be separated (p. 27)? carbon dioxide (p. 5)? A substance composed of two or more elements combined is a compound. In a mixture each substance keeps its own properties ; in a compound these give place to new properties belonging to the compound. Every chemical change involves either the forming or the decomposition (breaking-up) of a compound, usually both. Many substances may be decomposed by electricity. Tarnish on silver is one of these (p. 43).

The elements found in food ; some of their properties. — Foods consist of compounds formed chiefly from oxygen, carbon, hydrogen, and nitrogen, with small quantities of other elements. *Oxygen* is an invisible, odorless gas. It is a very active element, always ready to unite with other elements to form new compounds. The combining of oxygen with another element is called *oxidation*. The rusting of metals and the decay of organic matter are slow forms of oxidation. Oxygen forms about one-fifth of the volume of air, eight-ninths of the weight of water, and two-thirds of the weight of the human body. *Hydrogen*¹ is an invisible gas. It will burn, uniting with oxygen to form water. It

¹ The word hydrogen means "water-maker."

forms about one-ninth of the weight of water, and one-eleventh of that of the human body. *Nitrogen* is an invisible incombustible gas. It does not readily combine with other elements, and the compounds into which it enters break up easily. It forms about one thirty-ninth of the weight of the body. *Carbon* exists as an element in two forms, graphite, the so-called "lead" of pencils, and the diamond. It is most commonly met with in a slightly impure form as charcoal. Of all the elements, no other enters into so many compounds as does carbon. It is contained in all organic substances, as is shown by their blackening (carbonizing) when heated. Food also contains *chlorine*, a gas when uncombined; *phosphorus* and *sulphur*, solid substances, both poisonous when uncombined; and *calcium*, *potassium*, *sodium*, *magnesium*, and *iron*, all metals. It is plain that no element by itself is eatable. Nevertheless, chemical compounds of these elements make up our food.

Salts. — A salt is a compound resulting from the union of an acid with one of a class of substances called *bases*. Commonest among bases are the *alkalies* (pp. 33 and 108). Common salt (sodium chloride) can be made by adding hydrochloric acid to caustic soda. Calcium salts play the chief part in making water hard. Calcium carbonate causes temporary hardness. Calcium sulphate causes permanent hardness (p. 25).

Action of acids on metals. — Acids act on metals, particularly those exposed to dampness and air, forming salts or oxides of the metals. The staining of steel and the corroding of tin and other metal ware by potatoes, fruit, etc., are caused by the action of organic acids in the food. The salts formed in this way are likely to be poisonous. Food not naturally acid may become so by the action of bacteria. (See Sour milk, p. 96.)

BRIEF REFERENCE LIST

For further development of topics treated in this section see : —

SNELL : *Elementary household chemistry.*

VULTÉ : *Laboratory notes in household chemistry.*

DODD : *Chemistry of the household.*

RICHARDS AND ELLIOTT : *The chemistry of cooking and cleaning.*

BROWNLEE AND OTHERS : *First principles of chemistry.*

MORGAN AND LYMAN : *Chemistry.*

CHAPTER II

SOME STARCHY PLANTS

SECTION 1. THE POTATO

BAKED POTATOES

Select medium-sized potatoes, scrub them well, and dry them. Bake them in a shallow pan on the rack in a moderately hot oven until soft (usually about forty-five minutes). Turn them occasionally, that they may bake evenly. When soft, press them between the fingers, and break the skin to let the steam escape. Serve them folded in a napkin in an uncovered dish.

BOILED POTATOES

Put water to boil. Select potatoes uniform in size. Scrub or wash them, and if they are to be pared, pare them lengthwise, remove the "eyes" and any dark spots, and drop them into cold water.¹ Put them into a kettle with enough boiling water to cover them. When they have boiled twenty minutes, add salt, using one tablespoonful to six potatoes. When the potatoes can be pierced easily with a

¹ The cold water keeps them from discoloring. The oxygen of the air forms with the potato a dark-colored substance. This acid also stains the paring-knife.

fork or knitting-needle, drain off all the water, shake the kettle gently, sprinkle the potatoes with a little salt, cover the kettle with a cloth folded in several thicknesses, and let it stand in a warm place until the potatoes are served. Serve them uncovered.

A STUDY OF A WHITE POTATO

What is a potato? a root? Let us see if by examining one we can find out. On its surface are little scars, called

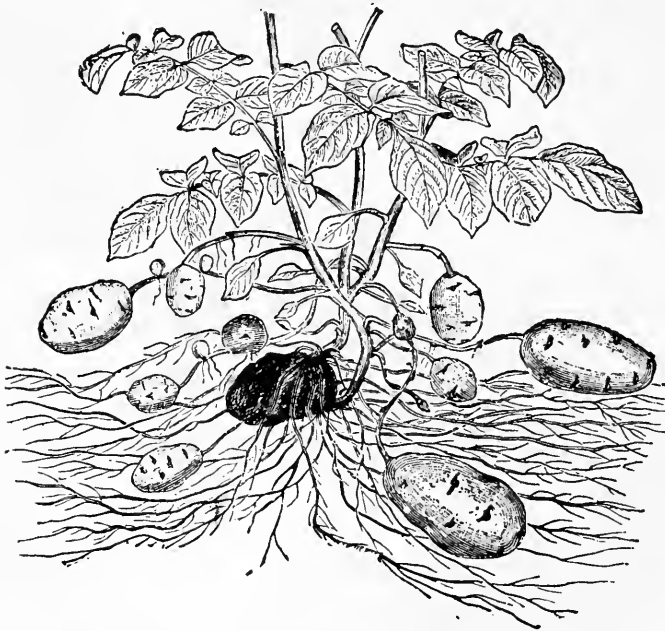

FIG. 6. — Potato-plant.

“eyes.” If a potato be buried in the ground in mild weather or kept in a warm, dark place, what happens? It *sprouts*; that is, the eyes send out green shoots that in time have leaves. These eyes, then, must be buds, and the potato a stem, not

a root; for, ordinarily, roots do not bud. A thickened underground stem, like this of the potato, is a *tuber*.¹ Potato roots are slender and fibrous.

¹ The sweet potato is a true root, but from its resemblance to a tuber is called a tuberous root.

Potatoes are grown from cuttings, not from seed, each piece planted being cut so that it has two or more eyes. Why not leave one eye only? Potatoes are planted in April and May, and harvested mainly in early autumn.

Hold a thin slice of potato to the light. Is its substance denser near the edges or at the centre? Can you make out an appearance of network? Note the thinness of the skin.

Analysis¹ of potato; experiments to find out what a potato contains.—

A. Pare and grate a piece of raw potato. Squeeze it in a piece of cheese-cloth held over a bowl. Rinse what remains in the cloth with cold water, and squeeze it as dry as you can. What does it look and feel like?

B. Let the liquid in the bowl stand until a white sediment settles; then pour it off carefully. Add a little water to the sediment and boil it. Does it act like anything you have seen before?

C. Mix one teaspoonful of cornstarch with one tablespoonful of cold water, add one-fourth cupful of boiling water, and stir until clear. Do the same with laundry starch. Dissolve about one teaspoonful of salt in one-fourth of a cupful of water; do the same with one teaspoonful of sugar. Add a few drops of *tincture of iodine* to a test-tube of water. Pour a little of this iodine solution into each of the starch pastes. What happens? Try a few drops in the salt solution; in the sugar solution. Has it the same effect on these as on the starch? (Plate V.)

Starch is turned blue by iodine. Since no other substance is affected in this way, iodine serves as a *test for starch*.

D. Add a drop or two of iodine solution to the white substance obtained from the potato. What do you think it is? Test a slice of potato for starch.

¹ Analysis (plural, analyses) means *separation into parts*. Chemists have made complete analyses of all kinds of foods. We can make only rough analyses of a few foods, and test them for the substances contained in them in considerable quantities.

COMPOSITION OF POTATO AS SHOWN BY ROUGH ANALYSIS

1. Plant fibre (partly <i>cellulose</i>).	Similar to fibre of wood. Forms walls of cells, or little divisions, in the potato.	Too tough to be digested; therefore of little food value.
2. Water.	About 75 % of the weight of the potato. Fills cells.	
3. Starch.	White insoluble powder floating in water in cells; with boiling water forms a jellylike paste.	The chief foodstuff in potatoes.

Potatoes also contain :—

4. More mineral matter than most other foods.	Lying mostly just beneath the skin.	
5. Other substances in such small quantities as to be of little food value.		

To find out how much water a potato contains, pare and weigh it. Lay it in a warm, dry place, weighing it every day until it ceases to lose weight by evaporation of its moisture. Compare the final weight with what it weighed at first. The difference between these shows how much water the potato contained.

To show mineral matter in potatoes, heat a bit of potato in a crucible or evaporating dish over a Bunsen burner till only gray ashes are left.

Experiment to show the relation between the sprouting of a potato and its composition. — Let a potato lie in a dark, warm place until it sprouts. Bring it to the light from time to time and observe the growth of the sprouts, also any change in the size of the potato. What do you think the sprouts feed on? Would a sprouted potato be as nutritious as an un-sprouted one?

How to choose and keep potatoes. — The tuber is a store-house of starch for the nourishment of the young shoot. In potatoes dug too early the starch is immature or unripe. In those kept too long after digging the starch has been partly changed to gum, a substance more serviceable than starch to the growing plant, but not so nutritious for man.

Potatoes are best (fullest of starch) in the fall and winter. Select those of regular shape, of medium size, and with smooth skin. A bushel of very large potatoes gives the purchaser less than a bushel of smaller ones, which pack more closely. Green bitter spots are caused by the potatoes' being grown too near the surface of the ground. Keep them in a cool, dry place. If sprouts appear pick them off.

Economy in paring and cooking potatoes. — Is the skin of a potato thick in proportion to the eatable part? Do we need to take off a thick paring?

By experiment it has been found that potatoes pared before being boiled lose much of their food value during cooking; for nearly one-fifth of the mineral matter, with some other soluble substances, and a little starch, passes into the cooking water. The longer the potatoes lie in water before they are cooked, the greater is this loss. New potatoes are best cooked in their "jackets." Any but imperfect or very old potatoes may be cooked this way.

They will not be as white as if they had been pared before cooking; but if one wishes to be economical, food-value should not be sacrificed to appearance. Old potatoes may have to be soaked to restore water lost by drying. Always pare potatoes *thinly*, and take out eyes with the *point* of the knife. To make the loss from pared potatoes as small as possible, put them at once into boiling water and as quickly as possible bring it to the boiling-point again.

HOW TO COOK POTATOES

1. Potatoes must be cooked till soft all through. Hard compact granules of raw starch, enclosed by walls of woody fibre, are not easily acted upon by the digestive juices. The object of cooking potatoes is to soften and break open these cell-walls and to soften and swell the starch.

2. Rapidly boiling water wears off the outside of the potato before the middle is cooked. Let it bubble *gently*.

3. If the outside of large potatoes becomes soft while the centres are still hard, add one pint of cold water. Enough heat remains inside of the potatoes to finish cooking them.

4. Since potatoes contain more than sufficient water to soften the starch in them, they may be baked. The excess of water is changed to steam during cooking, leaving the starch dry and flaky. If allowed to recondense, the starch reabsorbs it, making the potatoes "soggy" instead of "mealy," as they should be. Potatoes allowed to stand in water after they are cooked through absorb some of the cooking water with the same result. What precautions do

we take to avoid this? (See recipes for Boiled and Baked Potatoes.)

5. Potatoes baked in a slow oven become dry and hard. Quickly baked potatoes are more easily digested than boiled potatoes; slowly baked ones, less so.

6. Unusually large potatoes may be halved for baking.

RICED POTATO

Press boiled potatoes through a coarse strainer or a vegetable press into a hot dish.

MASHED POTATO

Mash potatoes (boiled without their skins) in the kettle in which they were cooked, using a fork or a *wire* potato-masher. When free from lumps, add for each pint of mashed potato or four medium-sized potatoes

1 tb. of butter, melted in
 $\frac{1}{3}$ c. of scalded milk,
 $\frac{1}{4}$ to $\frac{1}{2}$ t. of salt, and
 $\frac{1}{8}$ teaspoonful of white pepper.¹

Beat all together until light and creamy. Heap in a dish without smoothing the top. It may be put in a baking-dish, the top brushed with milk, and browned in a hot oven.

CREAMED POTATOES

Cut cold boiled potatoes into one-half inch cubes; put these into a saucepan, nearly cover them with milk, and cook gently until nearly all the milk is absorbed. Add

¹ Many people prefer white pepper on potatoes, in white sauce, and in any other food where black pepper would show distinctly.

white sauce, stir for one minute, sprinkle with finely cut parsley,¹ and serve.

WHITE SAUCE (for Vegetables)²

Butter, 2 tb.	Salt $\frac{1}{2}$ t.,	} mixed.
Flour, 2 tb.	Pepper, $\frac{1}{8}$ t.	
Milk, 1 c.		

Rub flour and butter together with a spoon in a small saucepan. Add milk, and stir steadily over a moderate heat until the sauce boils. Add salt and pepper.

For richer white sauce use part cream. Cream sauce is white sauce made with all cream instead of milk. Use one and one-half teaspoonfuls of flour to one cupful of cream.

SWEET POTATOES

Sweet potatoes are best baked. If to be boiled, leave the skins on, pare after cooking, and dry for a few minutes in a moderate oven. They may be riced.

Food value of potatoes. — Potatoes contain foodstuffs which meat lacks. Eaten with meat, they form an important article of diet, and one we do not tire of, particularly if they be cooked in a variety of ways. Sweet potatoes are more nutritious than white. They contain sugar in addition to the foodstuffs found in white potatoes.

¹ **To cut parsley.** — Pick off several sprigs; if wet, dry with a clean towel. Hold them in a firm bunch on a board or plate, and cut them through and through, repeating until very fine.

² This recipe makes one cup of sauce, enough for four moderate-sized potatoes, or one pint of potato cubes.





COLD OATMEAL MOLDED AND GARNISHED WITH SLICED BANANAS.

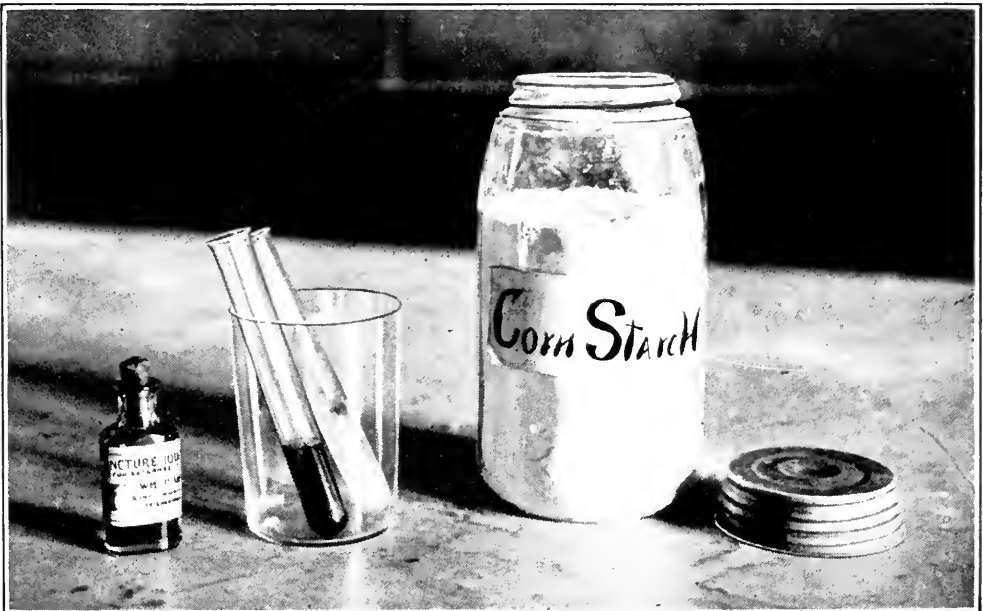

IODINE TEST FOR STARCH.

Diluted tincture of iodine in one test-tube, starch-paste stained by iodine in the other.

BRIEF REFERENCE LIST

For further development of topics treated in this section see: —

U. S. DEPT. OF AGRICULTURE: *Farmers' Bulletins*: 256. Preparation of vegetables for the table; 295. Potatoes and other root crops as food; 324. Sweet potatoes.

WARD: *Grocer's encyclopedia*.

WILEY: *Foods and their adulteration*. Pp. 288-305.

SHERMAN: *Food products*. P. 319.

SECTION 2. STARCH

SOURCES OF STARCH

Experiments. — A. Put one heaping tablespoonful of cracked or rolled oats with about one cupful of cold water in a small bowl; rub the oatmeal between your thumb and fingers for a few minutes, and observe the effect on the water. Fill a small test-tube (*a*) with the water and set it aside.

B. Half fill another test-tube (*b*) with the water and boil it. Compare the paste formed with that from potato starch (p. 61). Add a drop of iodine solution. What substance does oatmeal contain?

C. Soak rolled wheat, corn-meal, tapioca, rice, or any preparation used for breakfast mush, as you did oatmeal in Exp. A; boil the water, and test it for starch. Is there any substance common to all these foods? What is it?

D. Test any or all of the following substances for starch:¹ — flour, milk, fish, white of egg, cabbage, meat (in order to see the color, use cooked chicken, lamb, or veal), apple, turnip. Do any of the animal foods contain starch? Do all the vegetable foods contain starch? Explain why flour is used to thicken white sauce.

E. Pour off the water in test-tube *a* and dry the powder found at the bottom. Can you distinguish it in appearance and feeling from potato starch?

¹ Simply test with diluted tincture of iodine without adding water or heating.

All green plants contain more or less starch. They make it out of water and carbon and store it up in root, stem, or some other part, in the autumn, to nourish the young shoots in the spring. Plants obtain carbon from the carbon dioxide in the air. How do they obtain water?

Most of the starch we use is obtained from corn (maize), potatoes, wheat, and rice. It is a fine white glistening powder, insoluble in cold water, but partially soluble in hot water, with which it forms a jellylike paste. It is turned intensely blue by iodine.

A STUDY OF STARCH

Starch under the microscope. — Under the microscope starch is seen to consist of irregularly shaped granules formed of layers folded around a central point. Starches from different plants differ from one another; granules of potato starch are larger than those of any other kind and something like oyster shells in shape and marking. Rice starch granules are angular and very small. When cooked, the granules lose their distinctive appearance.

Experiments showing how to prevent starch from lumping while cooking. — **A.** Pour about two tablespoonfuls of boiling water upon one teaspoonful of dry cornstarch, stirring as you pour. What happens? Break open one of the lumps. What do you find inside? Would pouring boiling water upon starch be a good way to cook it? Why not?

When boiling water is poured upon dry starch, lumps form, because the starch first touched by the hot water swells suddenly, forming a sticky envelope around the rest, thus keeping it from swelling.

B. Repeat Experiment A, mixing one-half tablespoonful of granulated sugar with the starch before stirring in water. Result?

Explanation. — The grains of sugar, by separating the starch granules, give the granules room to swell and thicken the liquid smoothly.

C. Repeat Experiment A, mixing one-half tablespoonful of cold water with the starch. Note result and explain.

D. Mix one-half tablespoonful of starch with one-half tablespoonful of butter or other fat, add two tablespoonfuls of cold water, and cook, stirring until the mixture thickens. Result?

Starch cooked with water forms a paste.¹

Starch used to thicken sauces. — Starch is used to thicken liquid in making sauces and gravies. In what three ways may lumping be avoided? Which of these ways is used in making white sauce?

Starch, dextrin, and caramel. — Starch, heated dry, changes to *dextrin*, which is soluble in cold water. In browned flour part of the starch has undergone this change, lessening the thickening property of the flour, and at the same time part of the dextrin has been further changed to *caramel*, which causes the brown color. The brown crust under the skin of baked potatoes is largely caramel and dextrin. A temperature of 320° F. is required to dextrinize starch. Explain why dextrin is not formed in boiled potatoes.

Experiments in heating starch dry. — A. Heat about one tablespoonful of starch in a test-tube (or on a small tin pan kept for use in experiments). When brown, take out part of it and test it for starch, (1) by heating with water, (2) by adding iodine.

B. Continue to heat the rest of the starch in a test-tube, until black. What is the black substance? What do you observe on the sides of the test-tube?

¹The starch takes up the water in such a way that we cannot drive off the water and leave the starch as it was before.

Composition of starch. — Starch is composed of carbon, oxygen, and hydrogen. When heated, the two last pass off as water, leaving the carbon.

Digestion of starch. — Food after being eaten undergoes many changes before it can be absorbed by the body. This process of change we call digestion. One important step in digestion is to make all insoluble foodstuffs soluble foodstuffs. Saliva begins to digest starch in the mouth. Some of it is here changed first to dextrin and then to maltose, a kind of sugar. The saliva continues to act on it for a time in the stomach. Starch digestion is completed in the small intestine.

A substance in saliva, called amylase,¹ causes this change (p. 131). The test for maltose is Fehling's solution,² which forms with it a reddish or orange-colored substance.

Experiment to show the action of saliva on starch. — Make a thin starch paste (about one-half teaspoonful of starch to three or four tablespoonfuls of water). Cool it to the temperature of the hand. Divide this between two test-tubes; in a third collect some saliva. Pour part of the saliva into one of the tubes of starch paste. Add a few drops of Fehling's solution and boil. Note the color. For comparison treat first starch solution and then saliva in the same way. Do either of these change color? Does either saliva or starch alone contain maltose? Explain the presence of this sugar in the mixture of starch and saliva.

STARCH AS A FUEL FOR THE BODY

The work of the body. — How does eating help to keep us alive? Life involves activity; work, play, activity of

¹ Sometimes called ptyalin.

² A mixture of copper sulphate, caustic potash or soda, and Rochelle salts.

any sort, makes us hungry; food gives us energy to go on working and playing. Any activity that uses up energy is, in the scientific sense, work. Your muscles work as hard in playing a game as in going on an errand; and just as truly does the heart work in pumping blood, the stomach in digesting food, the brain and nerves in giving rise to thought and feeling.

What else does food do for us? Breathe on your fingers; your breath is warm. Evidently heat is produced in the body.

Experiment. — Blow into lime-water through a glass tube for a minute or two. What is the effect on the lime-water? In what other way have you produced the same effect? (p. 5.) What gas must there be in your breath?

Air from the lungs and air in which something has been burned both turn lime-water cloudy, because both contain carbon dioxide. A slow burning goes on in the body all the time. The oxygen in the air we breathe unites with substances in the body. Carbon dioxide is formed and goes back through the lungs into the air.

This process of slow combustion is necessary to the life of both plants¹ and animals. Without oxygen, life would go out as a flame does.

The body compared to a steam-engine. — Just as heat and mechanical power are produced by burning fuel under the boiler of a steam-engine, so energy and heat are produced by the oxidation of food in the tissues of the body. Starch slowly oxidized in the body gives off just as much heat and energy as if burnt (*i.e.*, rapidly oxidized) in the air. Thus food serves as fuel to warm the body and to keep its

¹Plants breathe through their leaves, taking in oxygen and giving off carbon dioxide, night and day. The making of starch, during which the plant takes in carbon dioxide, is a distinct process, which goes on only in the light (p. 68).

machinery running, and its oxidation, as in the case of other fuels, gives rise to carbon dioxide, water, and also to waste products corresponding to the ash of coal or wood. Ordinarily the oxidation of food for the production of energy supplies all the heat the body needs. Only to meet an extra demand is food used expressly for warmth. How is oxygen taken into the body? What combustible elements does starch contain? What other kinds of slow oxidation do you know of? (p. 34.)

The body, unlike an engine, repairs itself. — A steam-engine differs from the body, however, in one important respect, — it cannot repair itself. No fuel we can feed it with will stop a leak in the boiler or restore a missing rivet; but food renews the tissues of the body as fast as they wear out, making bone, nerve, muscle, and skin for us continually. Then, too, in a steam-engine, fuel and air meet and unite in one place, whereas in the body combustion goes on in all its parts.

Carbohydrates. — Starch is one of a class of foodstuffs called carbohydrates. As the name indicates, carbohydrates are composed of carbon and of hydrogen and oxygen in the right proportions to form water. They are good fuel foods. They cannot, however, build tissue, except fatty tissue, which is stored-up fuel rather than living tissue, such as muscle is.

Experiment. — Throw a bit of butter or lard and a bit of starch on the fire and see which burns best.

Fat contains the same three elements that carbohydrates do, but the proportion of oxygen is much smaller. Hence it unites with more oxygen and so burns better.

BRIEF REFERENCE LIST

For further development of topics treated in this section see : —

BEVIER AND VAN METER: *Selection and preparation of food*. Pp. 48-52.

THORPE: *Dictionary of applied chemistry*. V. 4, p. 149.

SHERMAN: *Food products*. Pp. 7-10, 259-263.

BIGELOW: *Applied biology*. Pp. 191-196.

RITCHIE: *Primer of physiology*. Ch. 15, Foods and why we need them.

FORSTER AND WEIGLEY: *Foods and sanitation*.

SECTION 3. CEREALS; BREAKFAST FOODS

Cereals, or grains, are grasses, the seeds of which are used for food; among the most important are wheat, Indian-corn or maize, oats, rice, rye, and barley. From these are prepared various breakfast foods, — oatmeal, wheatena, and others, besides corn-meal and other preparations sometimes served for breakfast.

Cereals compared with potatoes. — Cereals, like potatoes, contain starch. How may we prove this? If they were like potatoes in other respects, they could be cooked in much the same way. Unlike potatoes, however, they do not contain nearly enough water to soften the starch, and must, therefore, be so cooked that they can absorb more. All except rice contain much woody fibre tougher than that in potatoes, and so need longer cooking.

Breakfast cereals may be either boiled or dry-steamed. Steaming is the slower process, because the food in the upper part of the double boiler never quite reaches 212° F.; but is preferable, since it insures even cooking of the cereal,

prevents it from wasting or drying upon the vessel, as it does when a saucepan is used, and makes stirring unnecessary.

How to use a double boiler. — Fill the lower part one-third full of boiling water, and keep it boiling. Add more boiling water from time to time, if needed, to keep it one-third full. If allowed to stand over the fire, for even a short time, without water in the lower part, the boiler will become leaky and useless. Keep the two handles of the boiler in line, so that both parts may be readily lifted together.

See that both parts are dry before putting them away.

A home-made double boiler may be contrived by setting one saucepan inside of another.

STEAMED WHOLE OATMEAL

Oatmeal, 1 c.

Salt, 1 t.

Water, 4 c.

Put the water, with the salt, in the upper part of the double boiler, and set it directly over the heat. When it boils, stir in the oatmeal, put the two parts of the boiler together, and cook overnight, or six hours by a day fire. Reheat in the morning. *Or*, soak the oatmeal in the water for several hours, add the salt, and steam for three hours.

BOILED RICE

(To be served as a vegetable in place of potatoes)

Rice, 1 c.

Salt, 1 t.

Water, 2 qt. (or more).

Put the water in a saucepan to boil. Pick over and wash the rice. When the water boils rapidly, drop in the rice —

slowly, so as not to stop the boiling. If the grains settle to the bottom, stir once or twice with a fork. Boil rapidly, uncovered, from twenty to thirty minutes, or until the grains can be crushed between thumb and finger; add the salt when nearly done. Then turn into a strainer to drain, rinse with hot water, and dry in the serving-dish in the oven (with the door open) for a few minutes. Each grain should be white, soft, and distinct, the motion of the water keeping them separate, and the washing and rinsing removing loose starch that would tend to stick them together.

To wash rice. — Put it in a colander or strainer, and set this in a bowl of cold water; rub the rice with the hands; change the water, repeating until it is clear. Or, wash in a strainer under running water.

Breakfast-foods. — The starch in so-called “steam-cooked” cereals is not really cooked. Steaming softens the grains, however, so that the starch cooks more quickly than that in raw cereals. If you have to burn fuel on purpose to cook cereals, steam-cooked ones may be more economical, although their cost per pound is greater and their weight includes the water absorbed in steaming. Package breakfast-foods are cleaner than those sold in bulk.

In good rice, the grains are of good size and unbroken, and keep their shape when cooked. Corn-meal and hominy spoil quickly; purchase them in small quantities. If you are troubled with mice or insects, keep cereals in jars or cans.

Fruit with cereals. — Try serving fruit with cereals: —

1. Serve berries, apple sauce, sliced peaches, or sliced well-ripened bananas in the saucer with the mush. 2. Stir

figs or dates, cut in pieces, into mush before serving it. (Especially good with farina.) The mush may be molded with the fruit in it. 3. Serve cold molded cereals with peaches or bananas, sliced. (Plate V, facing p. 67.) 4. Serve baked bananas on separate plates. (For recipe see p. 234.)

DIRECTIONS FOR COOKING CEREALS

1. Stir the cereal gradually into the required quantity of boiling salted water, and cook over hot water until done. (See table on p. 79.)

2. To save time and fuel, soak uncooked cereals (Irish oats, cracked wheat, hominy, etc.) in cold water before cooking. Those requiring more than one hour to cook should be cooked the day before they are to be eaten and reheated in the morning. If necessary to hasten the cooking of a cereal, boil it from fifteen to thirty minutes, then steam until done.

3. Cook steam-cooked cereals, as a rule, twice as long as is directed on the package. Only by long cooking are cereals made wholesome and well-flavored; undercooked, as most people eat them, they occasion sickness often laid to other causes.

4. Stir coarse, flaky cereals as little as possible. Fine, granular cereals may be beaten. To keep these fine cereals from lumping, mix them with cold water instead of sprinkling them dry into boiling water.

5. Cereals should absorb all the water they are cooked in; if too moist when nearly done, cook uncovered for a time.

U. S. Department of Agriculture
Office of Experiment Stations
A. C. True: Director

Prepared by
C. F. LANGWORTHY
Expert in Charge of Nutrition Investigations

COMPOSITION OF FOOD MATERIALS.

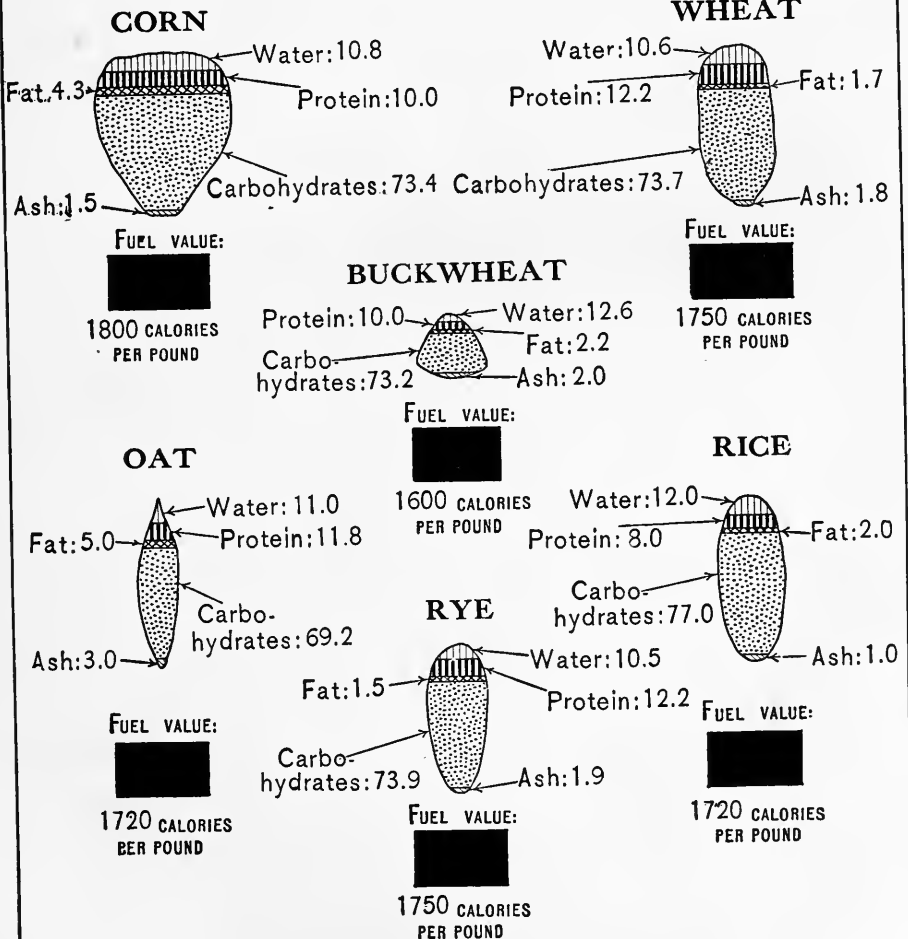

CHART 1.

6. To improve rice, farina, or hominy, stir in one-quarter of a cupful of milk about fifteen minutes before taking from the fire, and leave the cover off during the rest of the time.

Food value of cereals. — Cereals are the most important of vegetable foods. From the plains of northern Europe and Asia, where barley grows in a climate too cold for other grains, to the rice-fields of India and our Southern states, man depends on some cereal for his daily bread. One reason for this is that they contain in varying proportions all the kinds of foodstuffs necessary to support life. Containing so much starch as they do (50 to 75 %), they are valuable chiefly as fuel foods. Oatmeal and corn-meal have more fat than other grains, and so are especially good winter foods. Oatmeal is richer in food material, but on account of its indigestible fibre, less easily digestible, except for hard-working people, than other grains. Rice as commonly sold is almost pure starch.¹ As it contains no fat, we eat butter or cream with it.

HELPFUL HINTS ABOUT BREAKFAST CEREALS

1. Avoid eating undercooked cereals.
2. Have cooked cereal stiff enough to be chewed. If too soft, it is swallowed without being mixed with saliva.
3. Sugar, a carbohydrate, is not needed with cereals;

¹ Rice naturally has a brownish skin containing protein and mineral matter, but by "polishing" this skin is removed. Except for people who live chiefly on rice this loss is not serious. Polished rice is often coated with talc or glucose. So-called "unpolished rice" is often merely uncoated, not unpolished, but natural brown rice (unpolished) can be obtained from certain dealers.

milk and cream, on the other hand, supply fat and other foodstuffs of which cereals have little.

TABLE SHOWING TIME OF COOKING, AND PROPORTIONS OF SALT AND WATER, FOR BREAKFAST CEREALS

KIND	TEASPOONFULS OF SALT TO ONE CUPFUL OF CEREAL	CUPFULS OF WATER TO ONE CUPFUL OF CEREAL	METHOD OF COOKING	TIME OF COOKING, IN HOURS
Oatmeal (Raw)	1	4	Steam.	If soaked, 3; if not, 6 or more.
Oatmeal (Steam-cooked), Rolled Oats, H-O, etc.	1	1 $\frac{3}{4}$ or 2	Steam.	1 or more.
Rice	3	8 or more.	Boil.	$\frac{1}{2}$
Rice	1	2 $\frac{1}{2}$	Steam.	1
Wheat (Rolled and Steam-cooked) . . .	1	1 $\frac{1}{4}$	Steam.	1
Indian Meal	1	6 ¹	Boil.	If soaked, 3; if not, 6.
Hominy	1	4	Steam.	If soaked, 2; if not, 4.
Wheaten Grits	1	3 (or if soaked over night in 1 cup of cold water, add 2 $\frac{1}{2}$ cups of boiling water).	Steam.	If soaked, 2; if not, 3.
Farina and other fine wheat preparations .	1	4	Steam.	1 to 3

¹ If the meal is sprinkled in dry, continue adding it until it begins to float; after that, add no more.

Maize, commonly called corn, is native to America. Immense crops of it are raised in the middle West every year. It probably yields more products than any other cereal. Among these are meal, flour, starch, syrup, and oil. White and yellow corn-meal are equally nutritious, and if well-cooked, quite digestible. Adding wheat flour makes cornbread lighter.

BRIEF REFERENCE LIST

For further development of topics treated in this section see : —

WARD: *Grocer's encyclopedia*. (Article on cereals and articles on the different cereals.)

EARLE: *Home life in colonial days*. Ch. 6, Indian corn.

WILEY: *Foods and their adulteration*. Pp. 217-272.

U. S. DEPT. OF AGRICULTURE: *Farmers' Bulletins*: 298. Food value of corn and corn-products; 249. Cereal breakfast foods; 559. Use of corn, kaffir, and cow-peas in the home; 565. Cornmeal as a food and ways of using it.

MICHIGAN EXPERIMENT STATION: *Bulletin 211*. Breakfast foods.

JORDAN: *Human nutrition*. P. 304, Breakfast foods.

CORNELL UNIVERSITY: *Cornell reading course*. V. 3, pp. 86-103, Rice and rice cookery.

SHERMAN: *Food products*. Ch. 8, Grain products.

SECTION 4. WHEAT, THE KING OF CEREALS

Wheat is capable of cultivation in a greater variety of soils and climates than any other grain, and is also better suited for bread-making and for use as a constant article of diet. It has been called "the King of Cereals."

A STUDY OF WHEAT. — PART I

A. Note the elliptical scar at the base of a wheat grain. This shows where the germ, or embryo, lies, from which the seedling springs.

B. Crush a few grains of wheat, moisten them with boiling water, and test them for starch.

If sprouted grains¹ be tested for starch, much of it will be found to have disappeared, and, under the microscope, the granules left will appear rough, as if eaten into.

How the seedling is fed. — What has become of the starch? We have before seen that Nature is careful to provide food for baby plants. In what part of the potato plant is starch stored? What connection is there between that part of the plant from which the young plant springs and the location of the food supply?

The plant, like the human body, cannot make use of starch until it is digested. In what does the digestion of starch consist? This digestion in grains is effected by *diastase*, a substance developed in the seed during sprouting. What animal substance do you know of that can effect this change?

Kinds of wheat. — Wheat is called *winter wheat* or *spring wheat*, according to whether it is best suited to being sown in autumn or in spring. Wheat that endures the cold and dampness of winter is soft and starchy; wheat that comes up quickly in sunny spring weather is hard. Even spring wheat is soft in a rainy, cold season. These two sorts of wheat produce quite different kinds of flour, as you will learn in the next chapter.

Harvesting. — Where wheat can be sown in the autumn,

¹ Wheat and other cereals may be grown in earth or sawdust, or on moist blotting paper laid on a plate and covered with a glass jar or cheese-dish cover.

it ripens in early summer ; in the most Northern states not till autumn. When the ears are heavy and golden, it is cut down and bound into shocks. The grains are threshed out of the husks and sent to market. Until recently this work was done mostly by hand, but now steam-reapers, binders, and threshers are common on the great farms in the wheat regions.

Home-work. — Grow different kinds of grain at home in different ways ; make drawings of the seedlings in different stages of growth.

BRIEF REFERENCE LIST

For further development of topics treated in this section see : —

EDGAR : *Story of a grain of wheat.*

WARD : *Grocer's encyclopedia.*

SHERMAN : *Food products.*

WASHBURN-CROSBY COMPANY : *Wheat and flour primer.*

CHAPTER III

EGGS AND MILK

SECTION 1. EGGS; ALBUMIN

A hen's egg consists of shell, two layers of white, yolk, and two membranes, one a silky skin between shell and white, the other, so thin as to be invisible, between white and yolk. Two twisted cords of white extending from this inner membrane hold the yolk in place. The little mass in the yolk is the embryo from which the chicken grows, just as the seedling grows from the embryo of the seed. The contents of the egg, like the seed-contents, nourish the developing embryo; when ready to be hatched, the chick has absorbed all of these contents, and part of the shell. The egg is a perfect food for an unhatched chicken, as starch is for a seedling.

Eggs should have hard shells and deep yellow yolks. The color of the shell does not matter. For the wholesale market, eggs are sorted and small eggs bring a lower price. Fresh eggs have a delicate flavor and almost no odor. The white and yolk are distinct and easily separated.

THE CARE AND PRESERVATION OF EGGS

Eggs should be laid in clean nests and kept clean. As the shells are porous, washing may contaminate the eggs.

But of course, dirty eggs must be washed, and any egg may be wiped with a clean damp cloth just before being broken. Eggs spoil because of bacterial growth in them. Even new-laid eggs contain some bacteria. Eggs keep losing water by evaporation through the shells. Air enters to take its place, and with the air bacteria. (Explain why a stale egg often rattles, and why a very stale one may float.) Clean eggs kept cool remain for a week or more practically as good as when laid. But gradually they develop an unpleasant taste and odor, and the yolk clouds the white. Eggs not quite fresh enough to taste good cooked by themselves are all right for other uses. No housekeeper will use really bad eggs, but unless the government prevents their sale, we are in danger of eating such eggs in cakes and other foods made by unscrupulous bakers and manufacturers.

As hens lay best in spring and early summer, it is necessary to preserve some eggs for winter use. One way of doing this is to seal the pores of the shells against bacteria. The best covering is a solution of water-glass. This method can be used at home.

The second method is cold storage, used by dealers. Eggs do not freeze at 32° F., and at this temperature, although some changes take place, they remain fit for use for several months.

Experiment to find out the best temperature for cooking eggs. — Cook one egg (*a*) in boiling water for three minutes; another (*b*) in boiling water for ten minutes; put a third (*c*) into boiling water enough to cover it (about one pint in a small saucepan), remove the saucepan from the fire, and let it stand covered on the table from six to ten minutes. Break the eggs and compare their contents. In which is the white hard and the

yolk unchanged? In which is the white hard and the yolk sticky or partly dry? In which is the white a tender jelly and the yolk thick?

An egg put into boiling water and removed from the heat is, at the end of about ten minutes, evenly cooked through, the temperature of the water falling during this time to about 168° F. The temperature of the egg averages about 185° F.

Experiments. — Put a little white-of-egg in a test-tube; hold the test-tube and chemical thermometer in a vessel of water. Heat the water gradually. How does the white-of-egg look at 150° F.? at 180°? Stir with glass rod or a stick to show degree of solidity. Note appearance and degree of solidity at 212°. Keep the water boiling for several minutes; then take out some of the white-of-egg and examine it.

ALBUMIN. PROTEIN

White-of-egg consists chiefly of water and a substance called *albumin* (from a word meaning white). Albumin in its natural state is clear and soluble in water. In white-of-egg it seems sticky because enclosed by invisible cell-walls. When the white-of-egg is heated, the albumin hardens, or coagulates.¹

Albumin is one of a class of foodstuffs called *proteins*, or collectively *protein*.

How did we show that starch contained carbon, hydrogen, and oxygen? (pp. 69–70.) We can prove in the same way that albumin contains these three elements. Let us see if albumin contains any element not found in starch.

¹ Yolk albumin coagulates at a lower temperature than white albumin. In a “three-minute” boiled egg, however, the white is hard and the yolk nearly or quite raw, the heat not having had time to penetrate to the centre of the egg.

Experiment. — Heat some dried white-of-egg (albumin) with a little lime in a test-tube. Note odor of ammonia which comes off.

Ammonia contains nitrogen. There is no nitrogen in lime. Therefore the nitrogen must have come from the albumin. The presence of nitrogen in any protein may be shown by heating it with lime. A test for nitrogen in food is a test for protein.

Another test for protein is nitric acid (p. 151).

All proteins contain nitrogen. — Proteins may serve as fuel, like carbohydrates, but besides this they do what carbohydrates cannot do. They build living tissues, such as muscle, blood, nerves. Without nitrogen they could not do this. This tissue-building power associated with nitrogen makes proteins so different from other foodstuffs that writers have sometimes divided all foodstuffs into two classes, *nitrogenous* and *non-nitrogenous*. The importance of protein is suggested by its name, which comes from a word meaning "first." Foods containing considerable protein are called *protein foods*.

Digestion of albumin; gastric juice. — The digestion of albumin begins in the stomach, which secretes for the purpose a fluid called **gastric juice**, containing **pepsin** and **hydrochloric acid**. Gastric juice softens solid proteins such as cooked white-of-egg and changes all proteins into new substances. (For completion of process, see Chap. 15.)

Experiments to show how eggs are digested. — Label three test-tubes *a*, *b*, and *c*, respectively. Into *a* put about one teaspoonful of the finely chopped white of a hard-boiled egg; into *b* an equal quantity of the chopped white of a soft-cooked egg (see recipe), and into *c* a piece of hard-

U. S. Department of Agriculture
Office of Experiment Stations
A. C. True: Director

Prepared by
C. F. LANGWORTHY
Expert in Charge of Nutrition Investigations

COMPOSITION OF FOOD MATERIALS.



WHOLE EGG

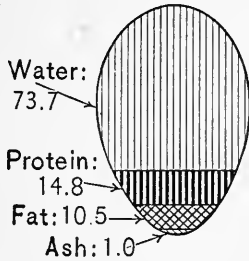

FUEL VALUE OF WHOLE EGG:



700 CALORIES PER POUND

EGG

WHITE AND YOLK

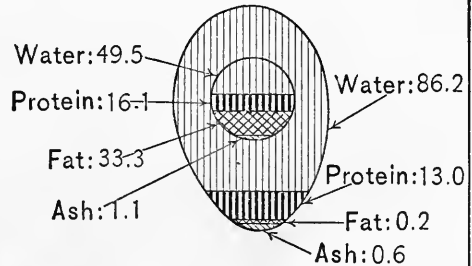

FUEL VALUE OF YOLK:



1608 CALORIES PER POUND

FUEL VALUE OF WHITE:



265 CALORIES PER POUND

CREAM CHEESE

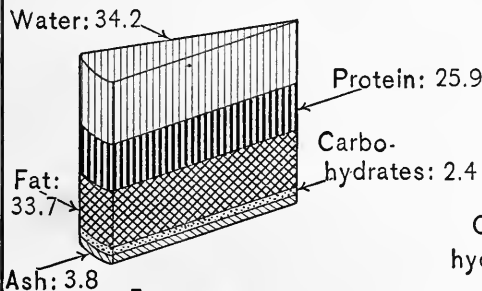

FUEL VALUE:



1950 CALORIES PER POUND

COTTAGE CHEESE

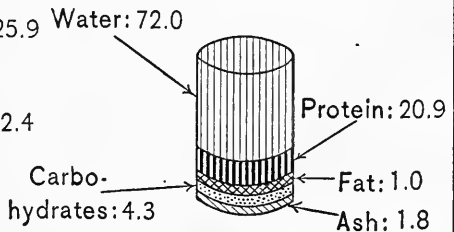

FUEL VALUE:



510 CALORIES PER POUND

CHART 2.

boiled white, not chopped. Half fill the test-tubes with pepsin and dilute hydrochloric acid,¹ and set them in warm water (about 98° F.).

At the end of an hour and a half examine them. In which has the white-of-egg been most rapidly liquefied, *i.e.*, digested? After five or six hours look at them again. If any of the egg is still undigested set it aside and look at it again the next day. Does white-of-egg digest more quickly in one piece or chopped? Which digests more quickly, hard-boiled or soft-cooked albumin?

Eggs are completely digestible. They contain no waste. They are most quickly and easily acted upon by gastric juice when cooked at a temperature not higher than 180. They are probably hardest to digest when fried.

Composition and food value of eggs. — Eggs are about three-fourths water. But of the nutritive material in them more than half is protein. This makes them one of the richest of protein foods, and so one of the most valuable as a tissue-builder. The mineral matter includes valuable compounds of calcium, iron, and phosphorus. One-third of the yolk is fat in the form of oil. What class of food-stuffs do eggs lack? What foods commonly eaten with eggs supply this lack?

Make a table showing the composition of eggs similar to that showing the composition of potatoes on p. 62. Potatoes contain a little albumin. It shows as froth on the water squeezed out of them, and coagulates if the water be boiled. Try this, and if you observe the albumin, note it in your potato table.

SOFT-COOKED EGGS

For two eggs allow one pint of water; for each additional egg three-fourths of a cup of water additional. Put the

¹ A digestive juice similar to that in the stomach may be made from 1.1 parts of pepsin and 7.5 parts of hydrochloric acid to 500 parts of water.

water in a saucepan, let it come to the boiling-point, lower the eggs into it with a spoon, remove at once from the fire, and let stand covered about ten minutes. The fewer the number of eggs to be cooked, the smaller should be the saucepan, in order that the smaller quantity of water may cover them.

TO TOAST BREAD

Cut stale bread (at least two days old) into slices one-third of an inch thick. Trim off the crusts, leaving the slices rectangular; lay the bread in a toaster, and hold over a bright coal fire, turning frequently in order that both sides may brown alike. Hold the bread well above the fire at first, to dry it; then nearer, until both sides are an even golden brown. Bread may be toasted on the grid in the broiling oven of a gas-stove. Toast thus made is usually dry all through. It requires close watching to prevent burning. A variety of contrivances for toasting over a top burner are on the market.

An electric toaster to be used on the breakfast table is a convenience in a house provided with electric current.

Toast may be buttered at once, but is more wholesome if buttered as it is eaten. Serve on a doily, on a hot plate, uncovered.

Water toast. — Dip the toasted slices quickly into boiling salted water (half a teaspoonful of salt to one cupful of water), using a fork. Spread with softened butter¹ and serve at once.

¹ To soften butter work it with a spoon or knife in a warmed bowl if necessary.

EGGS DROPPED ON TOAST

Prepare squares or circles (cut with a muffin ring) of water toast; arrange on a platter. On each break carefully a soft-cooked egg, keeping the yolk whole and in the centre of the slice of toast; sprinkle a little salt, and a tiny bit of white pepper, on each yolk, and serve. (Plate VII.)

Breaking and separating eggs.—To break an egg, hold it in the left hand and crack the shell by striking it sharply with a knife; then put your thumbs together at the crack, and gently break the shell apart. (Plate VI.)

To separate the yolk from the white, hold the egg upright while breaking the shell apart, so that the yolk will remain in one half of the shell: slip the yolk from one piece of shell to the other several times, letting the white run over the edge into a bowl or plate. *Caution.*—When using several eggs, if you are not *sure* of their freshness, break each singly into a cup, and examine it before adding it to the rest.

Beating eggs; distinction between beating, stirring, and folding.—Beat yolks in a bowl with a fork or a Dover beater; beat whites in a bowl with a Dover beater, or on a deep plate or platter with a fork or wire whisk. Whites are beaten *stiff* when a knife-cut made in the mass does not close; *dry*, when the gloss is gone from them, and flaky bits fly off as you beat. Yolks well beaten are thick and much lighter colored than before beating.

Eggs are beaten *slightly* (*i.e.*, until the white and yolk are mingled) to make them smooth and creamy, for French omelet, custards, and some sauces. They are beaten till

PLATE VI.



BREAKING AN EGG.



SEPARATING YOLK FROM WHITE.



MAKING BUTTER-BALLS.

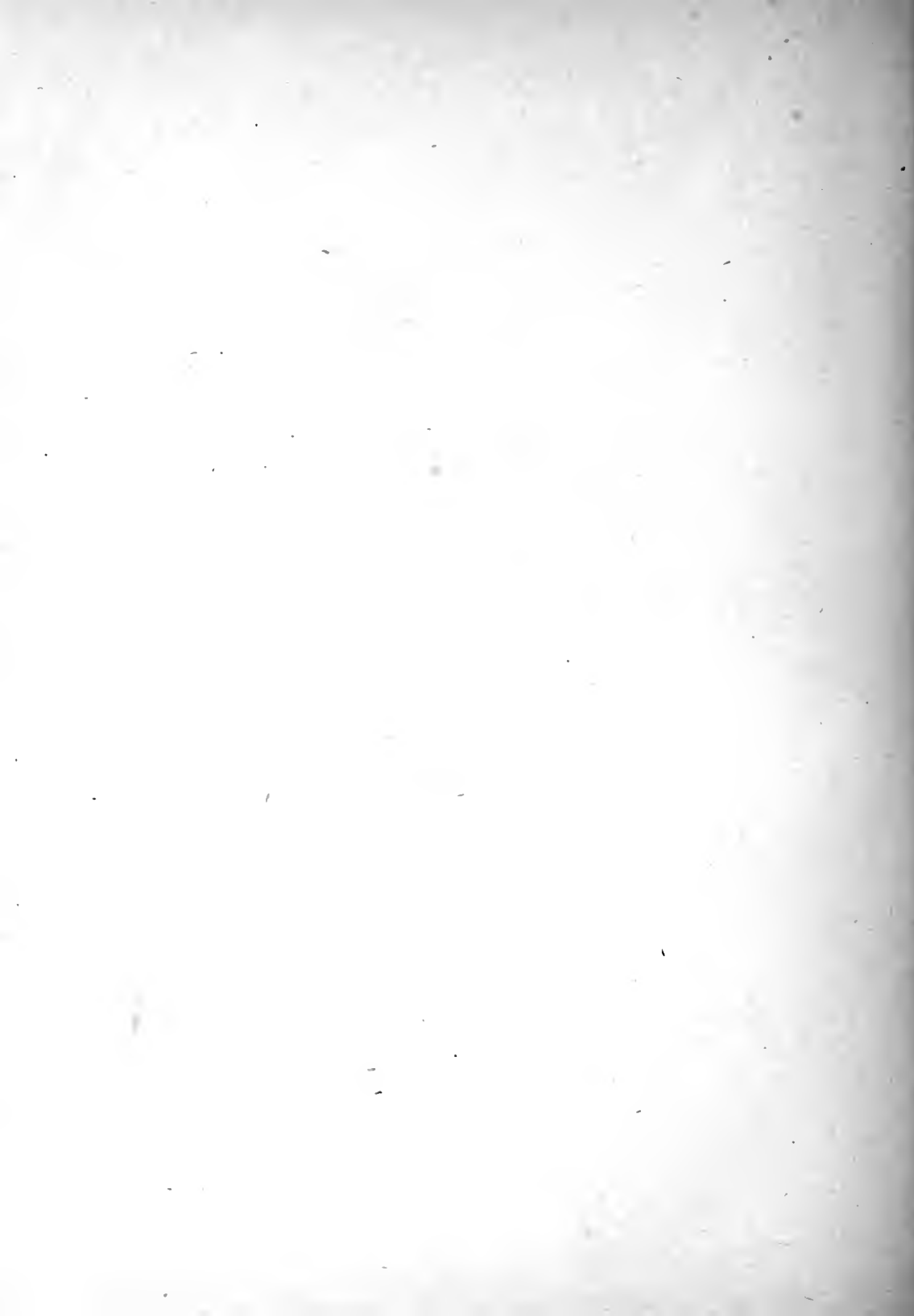

light to entangle air in fine bubbles in the albumin. Can you beat in more air by beating the whole egg or by beating the white separately from the yolk? To *beat* with a spoon or fork, carry it swiftly through the material, tilting the dish so that the material will be "flopped" over at each stroke. To *stir*, move the spoon steadily in a widening circle. To *fold* one ingredient into another, put the spoon in edge-wise, lift the ingredients, and turn them over; repeat until thoroughly mixed. Avoid stirring after beating or folding. Why?

EGG IN A NEST

Separate the white of an egg from the yolk. Beat the white stiff and dry; put it in a cup or small bowl, making in the top of it a hollow the size of the yolk; into this hollow slip the yolk. Cook in a covered saucepan containing boiling water until the top of the white is firm (about two minutes). Serve in the cup.

FRENCH OMELET

Eggs, 4.	Salt, $\frac{1}{2}$ to $\frac{3}{4}$ t.
Water, 4 tb.	Pepper, f.g.
Butter, 1 tb.	

Beat the eggs lightly (about twelve strokes with a fork), add water, salt, and pepper. Melt the butter in a hot omelet-pan without letting it brown. Turn in the eggs, shake pan gently, and as the egg thickens lift it lightly with a palette knife, letting the uncooked part run underneath. The omelet should slip on the pan without sticking anywhere. When it is creamy all through, roll it up, rolling toward the left side of the pan. Hold a hot platter over the edge of the pan, and turn pan and platter over, so that the

omelet will fall in the centre of the platter; or lift it out on two broad knives. Garnish with parsley, and serve *at once*; if it stands, it will fall.

The omelet is puffed up with steam from the moisture in the eggs and the water added to them. What happens to steam when it cools? What will be the effect on the omelet?

FANCY OMELETS

French Omelet may have spread over it, before it is folded, a rounded teaspoonful of fine-cut parsley, a few teaspoonfuls of chopped ham or other cooked meat, or of grated cheese. Or cooked, chopped oysters or clams may be used, or peas or tomatoes, — almost any cooked food; in fact, this is a good way to utilize “left-overs.” These fancy omelets are named according to the ingredient added, Cheese Omelet, Ham Omelet, etc. Have the filling hot when put into the omelet.

CUP CUSTARDS

Scalded milk, 1 qt.

Sugar, $\frac{1}{4}$ c.

Eggs, 4

Salt, $\frac{1}{4}$ t.

Nutmeg.

Beat the eggs slightly, stir in the sugar and salt, then, slowly, the hot milk. When the sugar has dissolved, pour into cups (about six), and grate a *little* nutmeg over each cup. Set the cups in a pan of hot water, and bake in a moderate oven until a pointed knife inserted in the custards comes clean. Do not let the water in the pan boil. Why?

The custard may be baked in one large dish, but it is harder to bake it evenly.

BRIEF REFERENCE LIST

For further development of topics treated in this section see:—

SHERMAN: *Food products*. Ch. 5, Eggs.

WARD: *Grocer's encyclopedia*.

OLSEN: *Pure foods*. Pp. 118, 138, 163.

U. S. DEPT. OF AGRICULTURE: *Farmers' Bulletins*: 128. Eggs and their uses as food; 87. Food value of eggs.

SECTION 2. MILK; BUTTER; CHEESE

What the seed is for the seedling, and the egg for the unhatched chick, the milk of an animal is for its young—that is, a perfect food. Why it comes nearer than eggs do to being a perfect food for any human being we shall see when we have found out its composition.

A STUDY OF MILK

Analysis of milk; experiments.—A. With a spoon remove the cream from one pint of milk that has stood overnight. Drop a little of the cream on unglazed paper. Examine the paper after it has dried for a time. Can you tell from the spot one foodstuff that is present in milk?

B. Test a little of the milk with iodine. Is there any starch in milk?

C. Boil the rest of the milk. What do you see on the top of it? What do you think this skin is? Is there water in milk? Air? How do you know?

D. Remove the skin and put a little of the milk in a test-tube. Add a few drops of vinegar. What happens? Strain the milk through a cloth, and examine the solid substance (*curd*) and the watery liquid (*whey*).

E. Shake a little white-of-egg and water together in a test-tube; add a few drops of vinegar, and note the coagulation.

F. Dry some of the milk-curd, heat it with lime, and note the odor of ammonia. What must the curd contain?

U. S. Department of Agriculture
Office of Experiment Stations
A. C. True: Director

Prepared by
C. F. LANGWORTHY
Expert in Charge of Nutrition Investigations

COMPOSITION OF FOOD MATERIALS.



Fuel Value
1/16 Sq. In. Equals
1000 Calories

WHOLE MILK

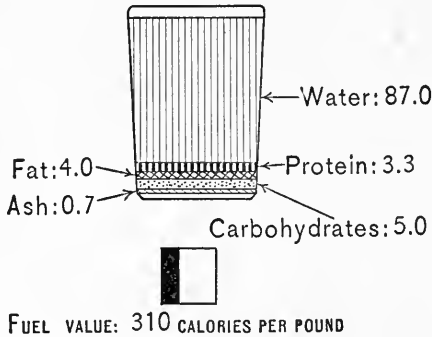

SKIM MILK

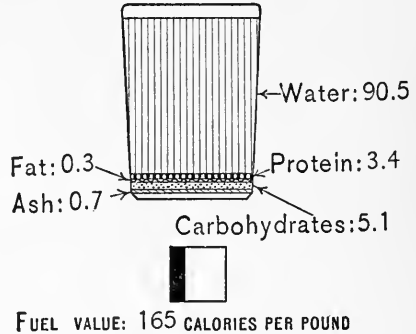

BUTTERMILK

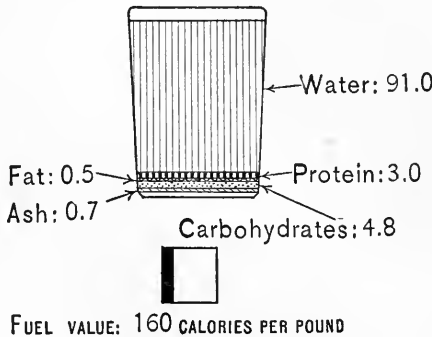

CREAM

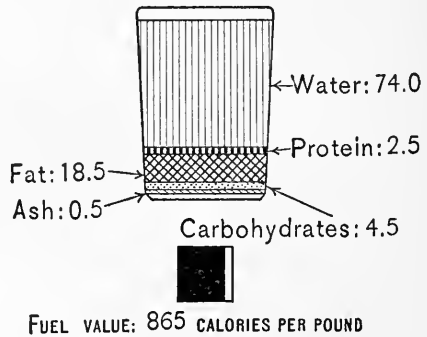

CHART 3.

Composition of milk. — Cow's milk contains fat, albumin, and a substance which is coagulated by vinegar but not by heat. This is *casein*,¹ a protein. Milk also contains a carbohydrate, *milk-sugar*, or *lactose*, and mineral matter. All of these except the fat are dissolved in water,² which forms almost nine-tenths the bulk of the milk. Name one element contained in casein that is lacking in milk-sugar. What difference does this make in its work in the body?

Food value of milk. — Milk serves all the purposes of food and drink. The protein in it builds all kinds of tissue. The protein, fat, and sugar all give heat and energy, and if not needed for the immediate use of the body they may be changed into fatty tissue. The mineral matter supplies calcium to harden bones and tissues, and phosphorus, some of which helps to build the nerves and brain. Some of the phosphorus is combined with casein. One can live upon milk for a long time. It is a good food to grow on, and it does not produce some of the acid and poisonous waste that meat does. We should do well to use more milk and less meat. (See pp. 142–143.) Mention some foods commonly eaten with milk. What foodstuff or foodstuffs, lacking in milk, do these foods supply? Remember that milk is food, not drink merely; less of other food is needed at a meal with which milk is drunk. Drink it slowly. It is more readily digested when taken in sips.

¹ Coagulated casein, when dried, is a hard, horny, yellow solid. It can be so toughened as to resemble celluloid, a state in which it is made into buttons and similar articles.

² The albumin is in true solution, the casein in partial solution only. In this state it is called by chemists *caseinogen* (casein-maker).

What good whole milk should be. — Fresh, unskimmed milk should be creamy white, and cream should rise on standing. There should be no dirt nor other sediment in it. Milk is one of the hardest foods to keep clean, pure, and sweet. It may *look* all right and yet be unfit for food. In most places where the milk sold comes from a distance, the law requires it to be up to a certain standard of quality and purity. Only bottled milk is safe to buy in cities.

Skim milk. — Skim milk is much cheaper than whole milk. Of course it contains little fat, but it contains more protein, sugar, and mineral matter than an equal quantity of whole milk.

Care of milk. — Put milk as soon as you get it in the coolest place you have. Wipe the mouth of the bottle before removing the cap. After pouring out what milk you need, cover the bottle, and set it away. Do not mix old milk with new. Keep milk away from anything with an odor.

Souring of milk. — G (continued from page 93). Let fresh milk stand in a warm room 24 hours, or until it thickens. Stir it, and notice the separation of the curd from the whey. What substance, added to milk, makes it separate like this? Taste the milk. How does it taste?

Sour milk. Lactic acid. — When milk is kept at the ordinary temperature, some of its sugar turns into lactic acid (milk acid), which gives the milk a sour taste, and like the acid of vinegar, coagulates the casein. As butter is usually made from sour cream (p. 100), buttermilk is sour. Either buttermilk or milk purposely soured by a special process makes a good drink, better for some people than sweet milk. (See Fermented milks, p. 332.)

Bacteria in milk. — The formation of lactic acid from milk-sugar is caused by the action of certain bacteria called lactic acid bacteria. Other kinds of bacteria spoil it in other ways, producing sliminess, bad odor, and other unpleasant effects. A few of these bacteria are disease germs. Bacteria grow rapidly in milk at ordinary temperatures. They get into it from unclean surroundings and from the air. Therefore in order to have milk when delivered as free as possible from bacteria, it must be drawn in a cleanly way, cooled, and kept cold in clean vessels protected from the air.

Pasteurization is a process in which milk is heated and then rapidly cooled. Its purpose is to kill any disease germs that may be present and to reduce the number of other microorganisms without injuring the taste or lessening the food value of the milk. The process is named after Pasteur, the eminent French bacteriologist. Pasteurization cannot make dirty milk clean. It can make clean milk safe. Properly pasteurized milk will keep longer than unpasteurized milk. It sours in time because not all the lactic acid forming bacteria have been killed.

Home pasteurization. — Pasteurize the milk in bottles before opening. Pasteurizers may be bought, but one can be contrived more cheaply. You will need a pail or kettle, a tin pie-plate, an accurate thermometer, and a clean bath-towel or other thick cloth. Punch a few holes in the pie-plate, and put it upside down in the kettle, to keep the bottles from touching the bottom. Punch a hole through the cap of one of the bottles, and insert the thermometer. Set the bottles on the plate in the pail, and fill the pail with water nearly to the level of the milk. Heat until the thermometer registers 145° F.¹ Remove the bottles. Take

¹ The temperature may go to 150° F. without harm, but no higher.

out the thermometer. Replace the punctured cap by a whole one. Cover the bottles closely with the cloth and let them stand from twenty to thirty minutes. Cool quickly by placing them in water. Have the water warm at first and run cold water into it to avoid breaking the bottles. After cooling, keep them on ice or in the coldest place you have. Pasteurized milk requires the same care as raw milk. (For more about milk see pp. 314, 315.)

COTTAGE CHEESE

Thick sour milk, 1 qt.

Salt, $\frac{1}{4}$ t.

Butter, 2 t.

Cream, enough to make cheese as moist as desired.

Heat the milk in a pan set on the back of the stove or set into another pan of hot water; as soon as the curd separates from the whey, strain the milk through a cloth. Squeeze the curd in the cloth until rather dry. Put in a bowl, and with a spoon mix it to a smooth paste with the butter, salt, and cream. Serve lightly heaped up.

Action of rennet on milk. — A different kind of coagulation of casein is produced by **rennet**, a substance prepared from the lining of a calf's stomach. Rennet is sold for use either in an alcohol solution ("liquid rennet") or in tablets, often called junket tablets.

RENNET CUSTARD OR JUNKET

Milk, 1 qt.

Extract of vanilla, 1 t.

Sugar, $\frac{1}{4}$ c.

Liquid rennet, 1 tb.

or

1 junket tablet dissolved in 1 tb. of water.

Heat the milk in a double boiler until it is lukewarm. Add the sugar and stir until it is dissolved. Stir in the vanilla and rennet, and pour it into glass cups. Let it stand in a warm room until it begins to thicken; then set it in a cool place, and leave it until it is firm. Sprinkle with one-eighth teaspoonful of cinnamon or nutmeg, and serve with cream (or milk) and sugar.

To make Coffee Rennet Custard, use two and three-fourths cupfuls of milk and add one and one-fourth cupfuls of strong, cold coffee after taking from fire. Use one-fourth to one-half cupful of sugar.

Does the curd formed by rennet differ in any way from that formed by an acid? If so, how? Does curdling make milk sour, or does souring make it curdle?

Digestion of milk. — *Rennin*, the ferment that gives rennet its power to coagulate milk, is secreted by the human stomach, as by the calf's, to prepare milk for digestion.

If milk is poured rapidly into the stomach, it forms with rennin a thick mass of curd. If it trickles in, it forms a flaky curd, much more easily digested. (For Digestion of Albumin, see p. 86, for Digestion of Sugar, pp. 269 and 370.)

BUTTER

Cream. — Fat naturally exists in milk in little spheres or *globules* about $\frac{1}{1500}$ of an inch in diameter. When fat or oil is suspended in this way in a liquid it is said to be emulsified.

Experiment to illustrate emulsion. — Shake some lime-water and linseed oil together in a bottle; hold the bottle still and observe the oil globules rise.

The fat globules, being lighter than the rest of the milk, tend to rise to the top as cream.

Making butter. — If cream be vigorously beaten or churned, the globules lose their shape and stick together, forming butter. Some of the casein clings to them. This should be washed out, as it decomposes easily. Butter is salted to protect it further from spoiling. It is usually packed in wooden tubs for market. Butter molded in “prints” for immediate table use is made less salt than tub butter. “Sweet” butter contains no salt and sells at a high price.

Milk from grass-fed cows makes yellow butter, but most butter comes so pale a color that it has to be colored for market. The coloring used is harmless. Good butter is firm, not crumbly, and yields little water when pressed.

Experiments. — **A. Butter-making.** — Put half a cupful of thick cream into a small bowl and beat it with a Dover egg-beater until it separates into buttermilk and specks of butter. Gather the butter into a lump, and after pressing out as much of the buttermilk as you can, wash the butter under a stream of cold water. Work with a wooden spoon to remove the water, and add a few grains of salt. Dip butter-spatters into hot water, then into cold, and with them roll the butter into a ball. (Plate VI, facing p. 90.) Use sweet or sour cream.

B. Test for butter. — Heat in separate dishes butter, butterine or oleomargarine, and renovated butter. Butter boils quietly, producing considerable foam. The others sputter, but foam little.

Butter is usually made from ripened cream ; that is, cream carefully soured to obtain a flavor produced by certain bacteria. Renovated butter is made from rancid butter by a process which makes it wholesome. (See butterine, p. 215.)

active people, it is one of the best of foods. We might well use it more in place of meat, as Europeans do. But if used in addition to meat or other nitrogenous food, only a little should be taken, as a relish. Cheese contains a very little sugar, and mineral matter. What foodstuff is lacking? What may we eat with cheese to supply this?

Cheese Fondue is hearty enough to form the main dish of a meal. See also recipe for Baked Macaroni with Cheese on p. 122.

CHEESED CRACKERS

Crackers (zephyrettes), 6.
 Grated cheese, about 6 r. t.
 Cayenne pepper, f. g.

Butter zephyrettes lightly, spread with cheese and cayenne well mixed, and heat on a pan in a hot oven till the cheese melts.

CHEESE FONDUE

Bread crumbs, 1 c.	Eggs, 2.
Milk, $\frac{1}{2}$ c.	Butter, $\frac{1}{4}$ c.
Grated cheese, $\frac{1}{2}$ c.	Salt, $\frac{1}{2}$ t.
Pepper, f. g.	

Butter a baking-dish. Cook bread crumbs and milk together, stirring until hot and smooth; add butter, cheese, salt, and pepper, cook one minute longer, and remove from the fire. Beat yolks and whites separately, the whites till stiff and dry. Mix the yolks thoroughly into the cheese mixture, and fold in the whites. Bake in baking-dish in hot oven fifteen or twenty minutes; when firm to the touch, the fondue is done. 1 Serve at once in the same dish.

Baked in ramekin dishes, this mixture forms Cheese Ramekins.

BRIEF REFERENCE LIST

For further development of topics treated in this section see:—

SHERMAN: *Food products*. Ch. 3 and 4.

OLSEN: *Pure foods*. Ch. 4, 5, and 7.

ROSENAU: *The milk question*.

ROSENAU: *Pasteurization*. (In U. S. public health and marine hospital service—Hygiene laboratory bulletin 56.)

WING: *Milk and its products*.

ELLIOTT: *Household bacteriology*. Pp. 55–60.

BUCHANAN: *Household bacteriology*. Ch. 26 and 30, Lactic acid fermentation; p. 297, Ripening of cheese; ch. 40, Milk and its contamination.

WARD: *Grocer's encyclopedia*. (Articles on milk, condensed milk, cheese, butter.)

HEALTH EDUCATION LEAGUE: *Booklet 2*. Milk.

U. S. DEPT. OF AGRICULTURE: *Farmers' Bulletins*: 413. Care of milk and its use in the home; 363. Use of milk as food; 490. Bacteria in milk; 487. Cheese and its economical uses in the diet. Bureau of Animal Industry. Circulars: 166. Digestibility of cheese; 126, 161, 184 (on pasteurization); 197. Directions for home pasteurization; 171. Fermented milks.

CHAPTER IV

BREAD

SECTION 1. QUICK BREADS; BAKING-POWDERS

Heretofore the dishes that you have cooked have consisted of one principal ingredient, with small quantities of others added to make this more palatable. In cooking you have had to consider the nature of but one, or at the most two, of the foodstuffs of which the principal ingredient was composed. What foodstuff did you consider in cooking eggs? in cooking cereals?

In this chapter you are to deal with mixtures of several kinds of food-material, and success will depend upon your understanding of the properties of each of the materials you use, and upon your care in measuring, mixing, and baking them.

Quick breads include biscuits, muffins, griddle cakes, and the like. They are so called to distinguish them from *yeast-breads*, which require a longer time for preparation.

POPOVERS

Flour, 1 c.
Milk, 1 c.

Salt, $\frac{1}{4}$ t.
Eggs, 2.

Put the flour in a bowl; make a well in the centre of it; drop in the salt, then the unbeaten eggs. Add the milk gradually, stirring in widening circles from the centre.

PLATE VII.



EGG IN A NEST, AND DROPPED EGG ON TOAST GARNISHED WITH PARSLEY.

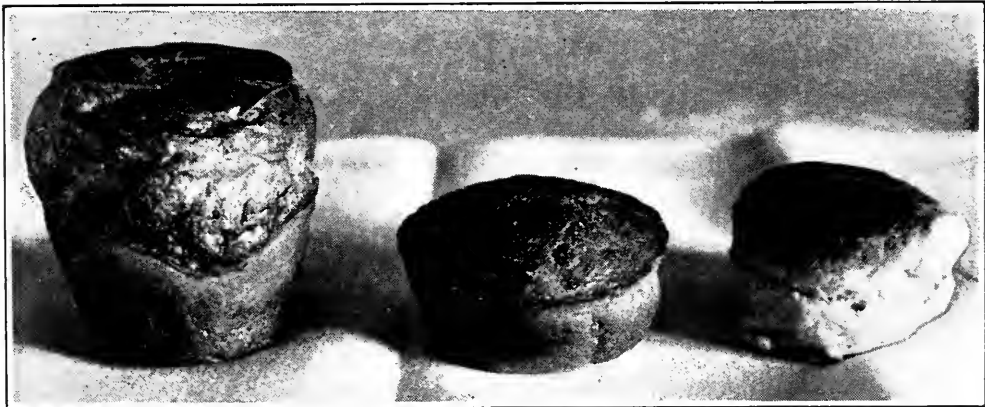

Popover

Muffin

Biscuit

QUICK BREADS.



FRENCH LOAVES, FINGER ROLLS, AND FRENCH ROLLS WITH BAKING PANS FOR EACH.



Bake in iron muffin-pans, or in earthen cups, in a hot oven for forty-five minutes. Reduce heat at the end of fifteen minutes.

To grease baking-pans. — Melt the butter or other fat, and with a bit of soft paper, or a brush kept for this purpose, apply it evenly to the pan, being careful to grease the corners carefully.

The uncooked popover mixture is called *batter*.

Popovers are made light by the expansion of the water in them as it is changed to steam by the heat of the oven, the heat at the same time forming a crust, which keeps the steam from escaping. When done the popovers should be crisp, hollow shells, several times the height of the batter, and well "popped-over."

BAKING-POWDER BISCUIT

Flour, 2 c.

Salt, 1 t.

Baking-powder, 4 t.

Butter, 2 tb.

Milk (or milk and water), about $\frac{3}{4}$ c.

Sift the flour, baking-powder, and salt together. Rub in the butter (which should be cold and firm) with the tips of the fingers or cut it in with a fork until the mixture looks like meal. Push the flour to one side of the bowl, and add the milk, a little at a time, tossing, not stirring, the flour into the milk with a broad knife or spatula, until a soft dough is formed. When all the flour is moistened turn it on to a floured board. Knead it for a minute with the hands. Pat and roll it lightly with a rolling-pin to a thickness of three-fourths of an inch. Cut into biscuit with a small biscuit-cutter dipped in flour. Bake on a pan from

twelve to fifteen minutes in a hot oven. For richer biscuits use from three tablespoonfuls to one-fourth cupful of butter.

GRIDDLE CAKES

Flour, 2 c.

Salt, $\frac{1}{2}$ t.

Baking-soda, 1 t.

Sour milk, 2 c.

Eggs, 1.

NOTE.—This recipe makes thin, delicate cakes. For thicker ones use two and a half to three cups of flour.

Put the griddle where it will be hot by the time the cakes are mixed.

Sift the flour, salt, and baking-soda together. Beat the eggs well. Stir the milk into the flour. Add the beaten egg, and beat all together until well mixed. Bake by spoonfuls on a hot greased griddle.¹ When the cakes are full of bubbles on top, and brown on one side, turn them over with a broad knife or a cake-turner, and brown them on the other side. If large bubbles rise at once to the top of the cakes, the griddle is too hot. If the top of the cake stiffens before the under side is brown, the griddle is not hot enough. Never turn a cake twice; a twice turned cake will be heavy.

Serve the cakes as soon as they are baked, piled (not more than three or four together) on a hot plate. Eat them with butter, butter and syrup, or butter and sugar.

In making griddle cakes with sweet milk, omit soda, and add two teaspoonfuls of baking-powder and one tablespoonful of melted butter.

¹ Beat the batter well before pouring a fresh batch of cakes upon the griddle.

The griddle. — A soapstone griddle is best. *Never grease it.* Grease an iron griddle with a piece of beef suet on a fork, or drippings applied with a swab made by tying a strip of clean cloth around the end of a fork or skewer. Leave no spot ungreased, but do not have more than just enough to keep the cakes from sticking. If they should stick, scrape the griddle clean before greasing it again.

What is put into griddle cakes that is not put into popovers? And what is put into biscuit (besides shortening) that is not put into either popovers or griddle cakes?

We do not depend upon steam bubbles to make biscuit and griddle cakes light. In the one case soda is used, in the other case, baking-powder, to lighten the mixture.

A STUDY OF BAKING-SODA AND BAKING-POWDER

Experiments. — A. Dissolve half a teaspoonful of baking-powder in about two tablespoonfuls of water. What happens? B. When the solution stops bubbling (effervescing) heat it (in a saucepan on the stove or in test-tube over a bunsen burner or a gas-stove burner). What effect has heat on the bubbling? C. While it is bubbling fast, hold a lighted match over the mouth of the test-tube. What gas is being formed? This gas may also be tested for by the apparatus shown in Fig. 7. What effect will the gas have on the lime-water (p. 6)?

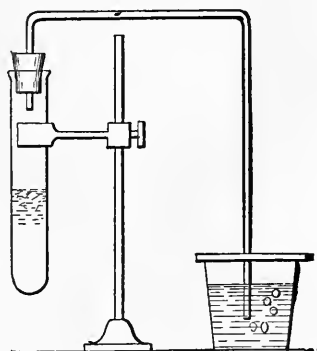

FIG. 7. — Apparatus for testing for carbon dioxide.

How baking-powder makes biscuit light. — When baking-powder is dissolved, carbon dioxide is formed and bubbles up. Heat increases the action. When the action takes place in a mix-

Test-tube (*t*) containing baking-powder solution. Glass tube connected with *t* dips into lime-water contained in glass (*o*).

ture during cooking, the thousands of bubbles of gas formed are caught in the mixture and baked in. This makes the biscuit, muffins, or cakes porous and light.

Experiments. — **D.** Dissolve a teaspoonful of soda in a fourth of a cup of water in one glass, and two teaspoonfuls of cream of tartar¹ in the same quantity of water in another glass. (Cream of tartar dissolves more readily in hot water than in cold.) **E.** Pour the two solutions together. Observe the effect and tell what you think causes it. **F.** If a further demonstration is desired, a little soda with about twice as much cream of tartar may be dissolved, heated in a test-tube, and the gas tested as in Exp. **B.** **G.** Add a pinch of soda or a little soda solution to sour milk; to vinegar. **H.** Taste cream of tartar. How does it taste?

How soda makes griddle cakes light. — Soda is a carbonate. When such a carbonate as soda and an acid meet in solution, they unite, and carbon dioxide is formed. In sour-milk 'griddle cakes the sour milk supplies lactic acid.

Baking-powder contains both soda and cream of tartar or some other acid.

Experiments. — **I.** Dip a strip of red litmus² paper into a soda solution. Dip a strip of blue litmus into a cream of tartar solution. Test with litmus paper sour milk, vinegar, washing-soda, soapy water, ammonia, a salt-solution, and a solution of baking-powder. Which of these substances turn red litmus blue? Which turn blue litmus red? Which do not alter the color? **J.** Taste griddle-cake batter. Test it with litmus.

Acids, alkalies, salts. — Any substance that turns blue litmus red is an acid. Any substance that turns red litmus

¹ Cream of tartar is a product of grapes. It is made by purifying the crystals, called "argols," which form in wine-vats.

² Litmus is a coloring matter made from lichens which grow on the coasts of Europe.

blue is an alkali.¹ A substance that does not affect the color of litmus is said to be neutral.² The union of any acid and any alkali used in cooking produces not only carbon dioxide, but a neutral salt. (See p. 57.)

Why sour-milk griddle cakes are not sour.—This explains why griddle cakes, although made from sour milk, do not taste sour. If just enough soda is used to neutralize the lactic acid, the batter will not change the color of litmus. Usually, however, more than enough soda is used, and the batter turns red litmus blue. The salt formed by the action of lactic acid on soda is harmless. One teaspoonful of soda is usually allowed to one pint of sour milk.

Different kinds of baking-powder. — A baking-powder which contains just the right proportions of soda and acid makes a neutral solution. It is important that the salt formed should be harmless. Cream of tartar forms with soda Rochelle salts. These are soluble. They have a slight medicinal effect, but in eating food raised with baking-powder, a person gets a very small quantity of the salt. Cream of tartar baking-powders, also-called tartrate powders, are among the best on the market. Two other classes of baking-powders are made. In one of these the acid used is acid phosphate. In the other it is alum. The salt left in food raised with phosphate powders is insoluble, but not

¹ Note that alkaline solutions feel slippery. Washing-soda and baking-soda are both alkaline carbonates. Washing-soda is sodium carbonate, baking-soda is sodium bi-carbonate.

² Water in which red cabbage-water has been boiled may be used instead of litmus paper as a test for acids and alkalies. Acids turn cabbage-water violet. Alkalies turn it green.

injurious. Alum powders leave an objectionable residue. Alum powders are cheap, but as they lose their strength sooner than tartrate powders do, and as they often contain considerable starch, an alum powder may not be as cheap as it seems.

Starch in baking-powder. — All baking-powders contain some starch, put in to absorb moisture. If the acid and soda are not kept dry, they begin to act, and some of the carbon dioxide is lost. If more starch than is necessary for this purpose is used, it is an adulteration. (See p. 53.) Baking-powder may be tested for starch (*a*) by boiling and (*b*) with iodine (p. 61).

To keep baking-powder dry, always cover the box as soon as you have taken out what you need.

Proportion of baking-powder to flour. — Use one to one and one-half teaspoonfuls of baking-powder to one cupful of flour. If more than this is required, the baking-powder is of poor quality. Bread or cake made with “generous” measures of baking-powder is dry, and contains an excess of Rochelle salts. One scant teaspoonful of soda and two level teaspoonfuls of cream of tartar are equal to three teaspoonfuls of good baking-powder. It is better to use a good baking-powder than to use soda and cream of tartar, because the housekeeper cannot proportion the two as accurately as the manufacturing chemist. Any excess of either is wasted, and may be injurious to health.

How the carbon dioxide raises the batter or dough. — As cream of tartar is only partly soluble without heat, little of the gas is set free until the mixture is put into the oven.

It then comes off rapidly, filling the batter or dough with bubbles, and making it rise higher and higher. As the gas expands, the walls of the bubbles stretch and become thin. Just at this stage, if the oven is right, the heat sets the mixture and imprisons the gas. In too hot an oven a crust forms before all the gas is set free; in too cool an oven the bubbles break and the gas escapes. In either case the result is heavy bread.

BATTERS AND DOUGHS

Dough means "that which is moistened"; batter means "that which is beaten."

One measure of liquid with one to one and a half measures of flour makes a thin or *pour-batter*.

One measure of liquid to two measures or a little more of flour makes a thick or *drop-batter*.

A mixture stiff enough to be handled on a board is a *dough*.

One measure of liquid to two and two-thirds measures of flour makes a *soft dough*.

One measure of liquid to three or more measures of flour makes a *stiff dough*.

What kind of batter is the popover mixture? What kind of mixture will the recipe for biscuit make?

Ingredients; means of lightening; shortening. — A mixture of flour and water or flour and milk alone would be, when cooked, hard and unpalatable. We have found that the introduction of carbon dioxide makes it light and porous, and that, in a watery batter cooked by intense heat,

the steam produced puffs the batter up. Eggs stiffen batters. (See Muffin Recipes.) With very glutinous flour (pp. 116 and 120) eggs are unnecessary except to make the bread richer. Fat *shortens* bread; *i.e.*, makes it more tender by separating the starch-grains of the flour. Butter gives a fine flavor; but less expensive kinds of shortening may often be used. (See p. 225.)

HELPFUL HINTS ABOUT MIXING AND BAKING QUICK BREADS

1. There are several good methods of mixing batters. As a rule, sift salt, flour, and baking-powder together. Butter may be cut into the flour, or melted and added after the other liquid.

2. Mix quickly and bake at once thin batters, those raised wholly with air and those raised by using soda and sour milk, or any other liquid acid which sets free at once almost all the available gas.

3. The proper degree of heat for baking must be learned by experience. In general, doughs require a hotter oven than batters do. Too great heat causes bubbles of air or gas to burst and run together, a condition which is to be avoided when a fine-grained bread is desired. Popovers, when baked, should be hollow shells, and so require a very hot oven at first.

4. Set the pan at first on the bottom of the oven; after the bread has risen it may be placed on the rack to brown the top.

5. Open and close the oven door gently — “as if there

were a baby inside" — and if it is necessary to move the pan while the bread is rising, do it carefully. A draft of cold air will cause the bubbles to collapse; a sudden jar will break them. In either case the bread will fall.

RECIPES

PLAIN MUFFINS

Flour, 2 c.	Salt, $\frac{1}{2}$ t.
Baking-powder, 4 t.	Butter, 1 tb.
Milk, 1 c. sc.	

Mix and sift the flour, baking-powder, and salt. Stir in enough milk to make a drop-batter, add the butter melted, and beat well. Bake about twenty minutes.

EGG MUFFINS

Flour, $1\frac{1}{2}$ c.	Milk, $\frac{3}{4}$ c.
Baking-powder, 3 t.	Eggs, 1.
Salt, $\frac{3}{8}$ t.	Butter, 1 tb.

Mix and sift the dry ingredients. Cut in the butter with the back of the fork. Beat the egg well, stir the milk into it. Make a well in the flour mixture, and pour in the milk and egg all at once. Stir in widening circles until well mixed.

Another way to add the butter is to melt it and add it last.

WHOLE-WHEAT MUFFINS

Flour, $1\frac{1}{2}$ c.	Salt, $\frac{1}{2}$ t.
Baking-powder, 3 t.	Butter, 1 tb.
Sugar, 1 tb.	Milk, $\frac{3}{4}$ c.

Mix and sift the dry ingredients. Stir in the melted butter and milk, and beat well. Bake in greased muffin-pans about twenty-five minutes.

QUICK NUT BREAD

Graham flour (unsifted), 2 c.	} to be mixed together thoroughly.
White flour, 1 c.	
Light brown sugar, $\frac{2}{3}$ c.	
Baking-powder, 1 t.	
Baking-soda, $1\frac{1}{8}$ t.	
Salt, 1 t.	
Buttermilk or sour milk, 2 c.	

Nut meats, cut fine, 1 c.

Stir the buttermilk into the flour mixture. When the batter is smooth, stir in the nut meats. Turn into a buttered bread pan, and bake one hour and a half in a moderate oven.

BOSTON BROWN BREAD

Rye meal, 1 c.	Milk, 2 c.
Corn meal, 1 c.	Molasses, $\frac{3}{4}$ c.
Graham flour, 1 c.	Salt, $1\frac{1}{2}$ t.
Baking-powder, 4 t.	

Mix the dry materials. Mix the milk and molasses, and stir them into the dry materials. Steam in a greased round brown-bread tin for about three hours, or divide into three greased $\frac{1}{2}$ -pound baking-powder tins, and steam for 1 hour. The tins should not be more than three-fourths full. They may be placed on the rack of a steamer or set into a covered vessel of hot water, with a rack or support of some sort in the bottom to keep them from bumping. If set into hot

water, grease the covers and put them on. If a single large tin is used, it may have a greased cloth tied over the top.

SOFT CORN BREAD

Dry hominy, 1 c.	Boiling water, 3 c.
Yellow corn meal, 1 c.	Milk, about 1 qt.
Lard, 1 tb.	Eggs, 3.
Baking-powder, 1 tb.	

Stir the hominy into the boiling water, and cook till soft. While hot, mix in the meal, lard, and milk. Beat the whites and yolks of the eggs separately. Add the yolks, then the whites. Sprinkle in the baking-powder last, and beat the mixture. Bake in a buttered dish 45 minutes. It should brown on top. Serve with a spoon with the meat course.

CORN-MEAL MUFFINS

Corn meal, $\frac{1}{2}$ c.	Salt, $\frac{1}{2}$ t.
Flour, 1 c.	Sugar, $1\frac{1}{2}$ tb.
Baking-powder, 3 t.	Milk, 1 c.
Eggs, 1.	Butter, 1 tb.

Scald half of the milk. Put the corn meal in a bowl, make a well in the centre, into the well put the salt and butter. Stir in the scalded milk.¹ Add the egg well beaten, the cold milk, and the flour and baking-powder sifted together. Beat well, and fold in the beaten whites. Bake in a hot oven thirty minutes.

Digestion of quick breads. — Quick breads are most delicious when fresh. No bread, however, should be eaten steaming hot, because in this state the inside part, or crumb,

¹ To soften and swell the grains. These are too coarse to be thoroughly cooked by baking.

forms in the mouth a pasty mass not easily digestible. The crust contains dextrin and caramel, and is therefore more wholesome than the crumb. Little children and all persons with weak digestive powers should never eat the crumb of warm bread; those who do eat it should chew it slowly and thoroughly.

BRIEF REFERENCE LIST

For further development of topics treated in this section see: —

SNYDER: *Human foods*. Ch. 12.

OLSEN: *Pure foods*. Ch. 16 and ch. 13, p. 143.

WARD: *Grocer's encyclopedia*. (Articles on baking powder and cream of tartar.)

KINNE AND COOLEY: *Foods and household management*. Ch. 11.

LYNDE: *Physics of the household*. Ch. 12..

SECTION 2. FLOUR

A STUDY OF WHEAT. — PART II. (See p. 80.)

Analysis of wheat-flour. — A. Make half a cup of flour into a very stiff dough with a little water. Knead this several minutes on a very fine strainer set in a bowl of water. Examine what is left in the strainer. How does it look? feel? Spread some of it on a saucer to dry and examine it again. Heat some in the oven, notice how it swells. (See Plate VIII.)

B. Test the sediment in the water for starch in two ways.

Gluten. — Wheat-flour, when kneaded with water, yields a yellowish gray substance that when moist is elastic and sticky like glue, and for this reason is called *gluten*. When dry it is horny and translucent. If moistened and heated, it expands to many times its original bulk.

Strictly speaking, gluten does not exist in wheat or in dry wheat-flour. What we do find is a mixture of *gliadin* and *glutenin*, which, when kneaded with water, unite chemically to form gluten. There is usually about twice as much gliadin as glutenin in good bread flour.

C. Test gluten for protein in two ways. (Pp. 86 and 151.)

Structure and composition of a wheat-grain. — The body of a wheat grain is largely starch and protein. The protein is mostly gluten.

This central mass is called the *endosperm*.

At one end of the grain is the *germ*. This is rich in fat and in tissue-building material both nitrogenous and mineral.

Around the outside of the grain is a layer, in some places a double layer, of large, square cells.

These contain nitrogenous material (*aleurone*). This layer is generally removed in milling. Outside of it are five coats of bran which contain mineral matter, including phosphates. All these food stuffs are stored in cells with walls of cellulose, but there is more cellulose in the bran than anywhere else.

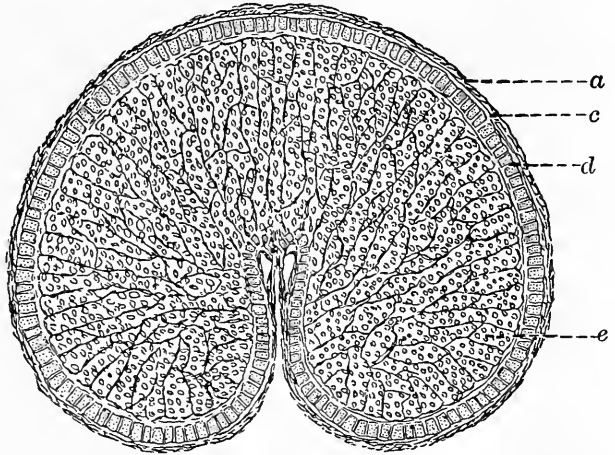

FIG. 8. — Cross-section of a wheat-grain, enlarged.

a and *c* = bran-coats; *d* = layer of aleurone cells; *e* = cells containing starch and gluten.

THE MANUFACTURE OF FLOUR

Cleaning. — If you ever visit a flour-mill you will be shown the wheat as it is shovelled from cars into bins, mixed with other seeds, and with dirt, sticks, and nails. It is freed from these by being run through sieves. Next it is either washed or scoured between brushes. Then it is heated, and if dry, moistened to toughen it. It is now ready to be rolled.

Rolling. — Each pair of rollers turns in the same direction, but one moves two or three times as fast as the other; both are grooved, so that they cut or break rather than crush the grain. Each passage between a pair of rollers is accordingly called a *break*. From the first break the wheat comes out warm from the friction of the roller and looking and feeling something like coarse, damp sawdust. Next it passes to a machine called a *scalper*, where it is shaken on a wire tray to separate the bran as far as possible from the *middlings*, or bits of the white middle part of the grain — the part to be made into flour. Then back go the branny parts to be ground over by a second set of grooved rollers, and again “scalped,” while the middlings are crushed between smooth rollers, sifted, mixed with other middlings from other breaks of the wheat, and ground over and sifted till completely reduced to flour. The number of breaks varies from four to ten.

Purifying. — Bran and other impurities are removed from both middlings and flour at each stage of the milling process by means of sieves to remove coarse particles and air-blasts to blow away worthless flour-dust. The final purification of

the flour after the last grinding, or *reduction*, is by air-blast and by sifting, or *bolting*, through silk gauze stretched over cylindrical frames called reels.

Having explained the milling process, the miller may show you a quantity of yellow disks the size of a pinhead. These are germs flattened out by the smooth rollers, and sifted out. If this were not done, the diastase in them (p. 81), which prepares the starch for digestion by the seedling, would spoil the flour by working in it the same change that it does in the seed.

Packing. — Lastly, you may see the finished flour packed by machinery into barrels and sacks to be sold, some of it, perhaps, to the farmers who raised the wheat it is made of, some to city people who never saw a wheat field.

Kinds of flour. — Flour made by the process described above contains as much of the foodstuffs of the wheat as can be retained while excluding the germ and the bran. Most mills make several grades of such flour. The best quality, known as “high-grade patent,” is made from middlings, as described above. Lower grades are sifted out after each break.

True graham flour is unbolted meal made from whole wheat including the bran. Imitations sold as graham flour are mixtures of low-grade flour, bran, and other by-products of milling. So-called “entire wheat” or “whole wheat” flour has not always been what its name indicated. It contained the aleurone but lacked part of the bran and much valuable mineral matter. It has been proposed to call such flour *bolted wheat meal*, and graham flour *whole* or

unbolted wheat meal, so that the housewife may know what she is getting.

Good bread flour, and how to tell it. — Glutinous flour, besides being more nutritious than starchy flour, makes the elastic dough necessary for producing light yeast bread. Hard spring wheat, being rich in gluten, yields such flour. You may know it (1) by its creamy white color, (2) by its gritty feeling, (3) by its caking but slightly when squeezed in the hand, and (4) by its capacity for absorbing water. One quart of good flour will take up nearly one and one-half cupfuls of water in making dough stiff enough for yeast bread.

BRIEF REFERENCE LIST

For further development of topics treated in this section see : —

EDGAR : *Story of a grain of wheat.*

GRANT : *Chemistry of breadmaking.* Ch. VIII, Milling.

SHERMAN : *Food products.* Pp. 268–279.

DOOLITTLE : *Why bleached flour should not be used.* (In *Housewives' League Magazine*, June, 1914.)

SNYDER : *Human foods.* Ch. 10.

U. S. DEPT. OF AGRICULTURE : BUREAU OF CHEMISTRY BULLETIN. 164. Graham flour. BUREAU OF PLANT INDUSTRY. Bulletin 20. Manufacture of Semolina and Macaroni.

SECTION 3. MACARONI AND OTHER FLOUR PASTES

Macaroni, spaghetti, vermicelli, and other pastes are to Italians what our various kinds of bread are to us. The best macaroni is made from semolina, the purified middlings of durum or macaroni wheat, which is exceedingly hard and glutinous. Bread flour also may be made from durum

wheat. To make macaroni and similar pastes, a stiff mixture of semolina and hot water is placed in an iron cylinder, the end of which is closed by a disk pierced with holes. A piston forces the paste out through these in threads, rods, or tubes, according to the shapes of the openings. When dry, the threads form vermicelli (Italian for *little worms*), the rods, spaghetti (Italian for *cords*), and the tubes, macaroni (Italian for *crushed*). Macaroni is dried by hanging over wooden rods in the open air or in ovens.

American macaroni was formerly made from the flour of ordinary wheat and so was of poor quality. More and more is now made every year from semolina.

How to know good macaroni. — Good macaroni is yellowish in color and rough in texture. It breaks cleanly without splitting, in boiling swells to at least double its bulk, and neither becomes pasty nor loses its tubular shape.

Macaroni contains so much protein that it is almost equal to meat as a food, especially if cooked with cheese.

Spaghetti may be prepared in any way suitable for macaroni, but is usually served with Tomato Sauce.

Vermicelli is used only in soups. Noodles, to serve in soup, are made in various shapes from a paste of flour, water, and eggs.

To grate cheese. — Use Parmesan, or any cheese stale enough to be dry. Grate on a coarse grater, and do not pack the grated cheese in measuring it.

To prepare buttered crumbs for scalloped dishes. — Mix dried crumbs (p. 134) with melted butter, using one-fourth of a cupful of butter to one cupful of crumbs.

TOMATO SAUCE

(for Spaghetti, Macaroni, or Boiled Rice)

Tomato (canned or stewed), $1\frac{1}{2}$ c.	Flour, 2 tb.
Onion (chopped), 1 t.	Salt, $\frac{1}{2}$ t.
Butter, 2 tb.	Pepper, $\frac{1}{8}$ t.

Cook the onion and tomato slowly fifteen minutes. Mix butter and flour together. Strain the tomato and add it to the butter and flour. Cook all together, stirring, until it boils; then add salt and pepper.

SPAGHETTI WITH TOMATO SAUCE

Spaghetti, $\frac{1}{3}$ of a box.	Salt, 1 tb.
Boiling water, 2 qt.	Tomato sauce.

Hold the sticks of spaghetti in a bunch, and dip the ends into the boiling salted water. As they soften and bend, lower them into the water, letting them coil around in the saucepan. The spaghetti may thus be cooked without breaking. Boil for twenty minutes, or until soft, drain, rinse with cold water (to remove starch that might make it sticky), and mix with the tomato sauce.

Sprinkle with grated cheese, to make Spaghetti Italian Style.

BAKED MACARONI WITH CHEESE

Macaroni broken in one-inch pieces, $\frac{3}{4}$ c.	Grated cheese, $\frac{1}{4}$ to $\frac{1}{2}$ c.
Boiling water, 2 qt.	White sauce (made from 2 tb. of butter, $1\frac{1}{2}$ tb. of flour, 1 c. of milk, and $\frac{1}{2}$ t. of salt).
Salt, 1 tb.	Buttered crumbs, $\frac{3}{4}$ c.

Boil the macaroni in the salted water for twenty minutes, or until soft. Drain in a strainer, and rinse with cold water.

Put a layer of macaroni in a buttered baking-dish, sprinkle with cheese; repeat until all the cheese and macaroni have been used; pour the white sauce over the top. Cover with buttered crumbs, and bake until these are brown. Or use a thick layer of cheese on top, and no crumbs.

SECTION 4. YEAST BREAD; YEAST

The perfect loaf of bread is regular in shape, has a crisp crust, evenly browned, and a tender, but rather firm crumb of even grain. It tastes sweet and nutty, smells fresh, and keeps good for several days. How may we make such a loaf? The ingredients are few; the process is simple; and, with care, skill is not hard to acquire.

WHITE BREAD

Flour, from 3 to 3½ c.	Lukewarm ¹ water, 2 tb.
Cold water, ½ c.	Compressed yeast, ½ cake.
Milk, ½ c.	Salt, ¾ t.

Mixing. — Scald the milk²; sift and measure the flour (three and one-half cupfuls); put the salt in a bowl and pour the milk upon it. Add the cold water, then the yeast mixed smoothly with the lukewarm water. Having stirred all together, stir in enough flour (about two and three-fourths cupfuls) to make a drop-batter. Beat this batter until it is full of bubbles; then beat in gradually enough more flour to make a rather soft dough. When too stiff to beat, rub a little flour on the molding-board, and turn the dough out.

¹ Of the same temperature as your hand, 98° F.

² To kill bacteria in it. (P. 97.)

U.S. Department of Agriculture
Office of Experiment Stations
A. C. True: Director

Prepared by
C. F. LANGWORTHY
Expert in Charge of Nutrition Investigations

COMPOSITION OF FOOD MATERIALS.



WHITE BREAD

WHOLE WHEAT BREAD

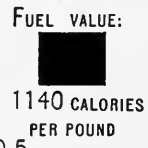
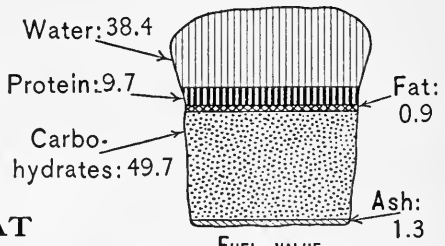
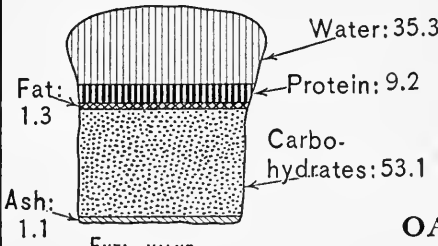

OAT BREAKFAST FOOD COOKED

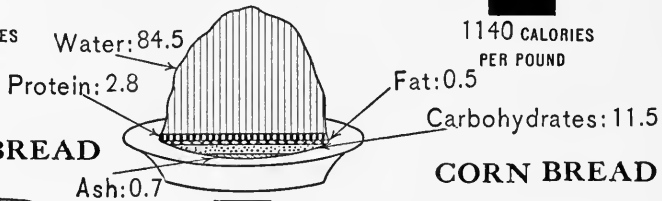

TOASTED BREAD

CORN BREAD

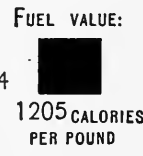
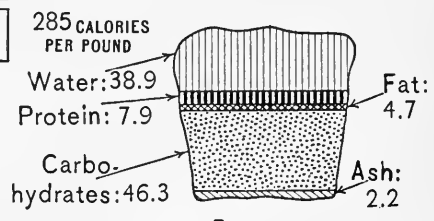
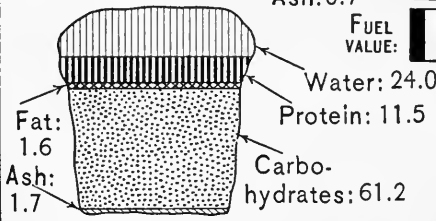

MACARONI COOKED

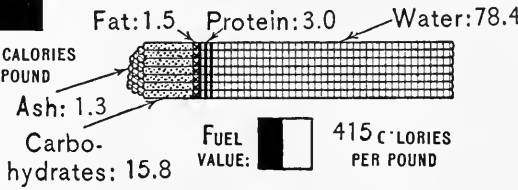

CHART 4.

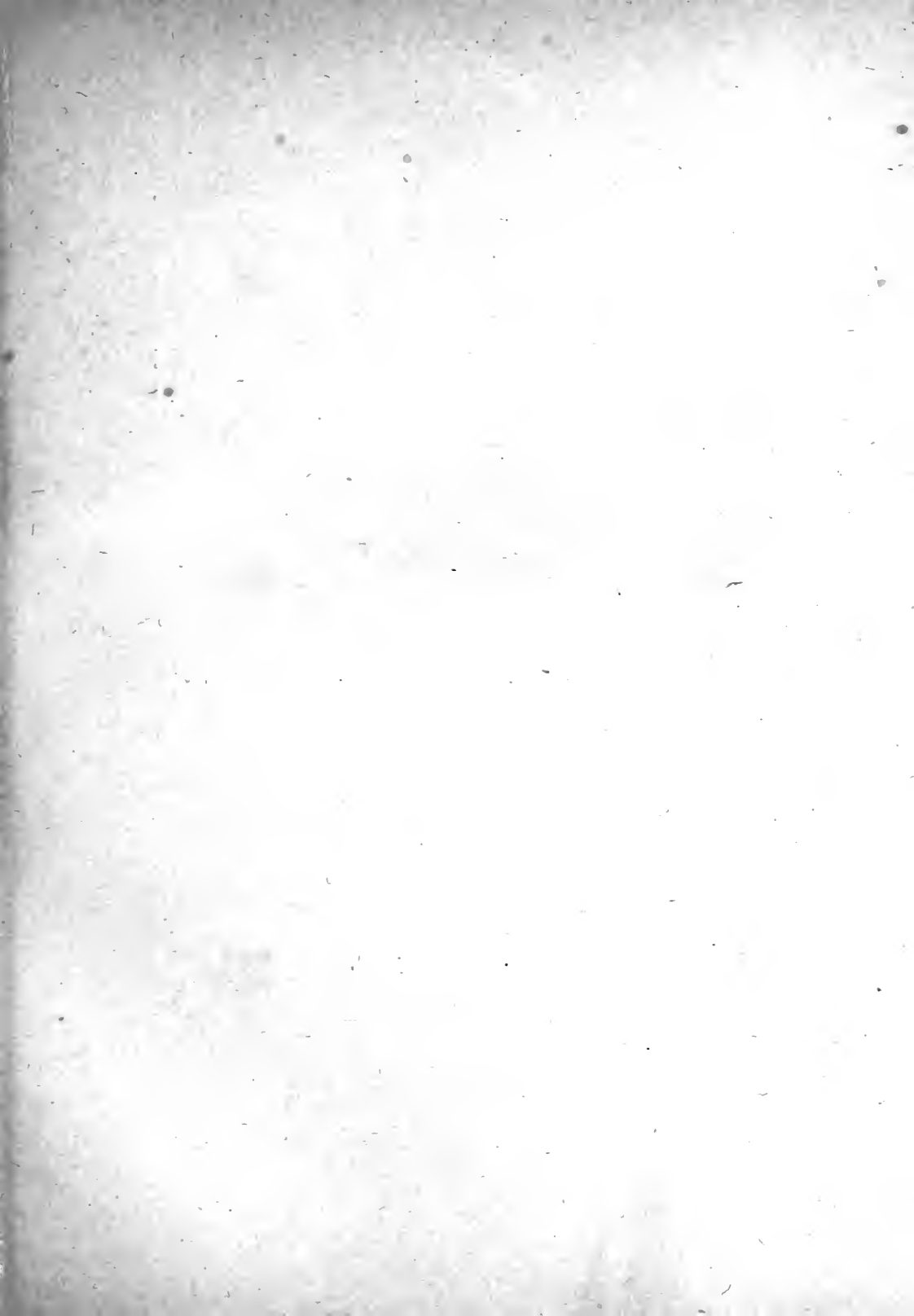

PLATE VIII.



SEPARATING GLUTEN FROM FLOUR.



KNEADING BREAD.



FIRST RISE OF BREAD DOUGH; TAKING THE TEMPERATURE OF THE WATER.

Kneading. — Dust a little flour on the dough and on the palms of your hands. Fold the edge of the dough farthest from you toward the centre of the mass, immediately pressing the dough down and away from you with a gentle rolling motion of the palms of the hands, twice repeated. Turn the dough so that what was the right-hand part of it shall be farthest away from you; fold over and knead as before; continue to do this, turning the dough and flouring your hands, the board, and the dough, to keep the dough from sticking. Should it stick to the board, scrape it free with a dull knife and flour the board anew. Knead the dough until it does not stick to your hands or the board, is smooth on the surface, feels spongy and elastic, and rises quickly after being indented.

The use of a bread-mixer saves labor and is more sanitary than kneading by hand.

First rising. — Replace the dough-ball in a wet bowl, brush the top with water, cover the bowl with several thicknesses of cloth, and set it near the stove or in a pan of warm water, turning another pan over it.

Second rising. — When the dough has risen to twice its original bulk, lift it on to the board and shape into small loaves, handling lightly and using no additional flour. Put into pans, and let it stand in a warm place covered with a thick, clean cloth, until it has again doubled in bulk.

Baking. — When the dough is nearly risen, test the oven; it should be hot enough to turn a piece of writing paper dark brown in six minutes. Bake small French loaves thirty-five minutes; brick loaves, four inches thick, fifty to

sixty minutes. Turn the pans if the bread does not bake evenly.

PLAIN BREAD ROLLS, FINGER ROLLS, AND BREAD STICKS

Shape these from white bread-dough after its first rising. For bread rolls, cut or pull off pieces the size of an egg; draw up and pinch the edges together, forming balls; then with your hand roll each into a cylindrical shape on the board. Put into French roll-pans, let rise until more than doubled in bulk, and bake from twelve to fifteen minutes. Or, put the balls on a flat pan, and when they have risen cut a cleft nearly an inch deep across the top of each one. Bake twelve to fifteen minutes. For finger rolls, roll pieces of dough half the size of an egg into cylinders five inches long. For bread sticks, roll out sticks of dough about half an inch thick and from six to ten inches long. Bake these and finger rolls ten minutes. The oven may be a little hotter for rolls than for loaves. (Plate VII, facing p. 104.)

Sponging. — Bread may be allowed to rise once when only a part of the flour has been added. This method is called sponging, or setting a sponge. It makes the bread finer-grained, but lengthens the process for white bread which requires two more risings after the rest of the flour is added. Sponge rises faster than dough. Why? It is desirable to set a sponge (1) if you have to make bread with a scant quantity of yeast; (2) when using home-made or dried yeast; (3) if there is no warm place for the bread to rise in; (4) when butter and eggs are to be added, as these can be mixed more easily with sponge than with dough. It is a good method to use with whole-wheat bread.

WHOLE-WHEAT BREAD (with a sponge)

Whole-wheat flour, about 3 cupfuls.	Compressed yeast, $\frac{1}{2}$ cake.
Lukewarm water, $1\frac{1}{4}$ c.	Salt, $\frac{3}{4}$ t.
Sugar, 2 tb.	

Mix the yeast smoothly with one-fourth of a cupful of the water; dissolve the salt and sugar in the rest of the water in a bowl; stir the yeast into this; and then stir in enough flour to make a drop-batter. Beat until the batter is full of bubbles (not less than five minutes), cover the bowl, and let the batter, or *sponge*, rise until doubled in bulk. Stir in the rest of the flour, and beat thoroughly. Turn into pans, and let rise until not quite doubled in bulk, and bake like white bread. If whole-wheat dough were made stiff enough to be kneaded, the bread would be tough and hard. If the sponging method is not used, beat in all the flour at once, let rise, beat again, and turn into pans.

Variations in bread-making. — Either white or whole-wheat bread may be mixed with water, milk, or half milk and half water, as may be preferred. Water bread is sweeter, tougher, and keeps longer than “half-and-half” or all-milk bread. Bread requires neither shortening nor sweetening, but most people like to add one tablespoonful of shortening (butter, lard, or other fat) for each cupful of liquid. Melt shortening in hot milk or water. Wait till it is lukewarm before adding yeast.

These two kinds of bread contain neither soda nor baking-powder. What do they contain that is not used in quick breads? Does yeast make bread light? and if so, how? The first thing to find out is: —

What yeast is. — Yeast is a mass of tiny plants, each a single, rounded cell consisting of a sac filled with watery matter. Under a microscope new cells may be seen budding out of old ones, forming branching chains. Each cell, however, lives and grows independently. Sometimes bodies known as *spores* form inside of mother-cells and burst out. Like seeds, spores can keep alive under conditions under which the plants they came from would die. Sometimes under unfavorable conditions *resting-cells* with thick walls are formed. These live, but do not bud till conditions are right again. The home of yeast is on the skin of grapes and on parts of some other plants.

A STUDY OF YEAST

The growth of yeast; experiments. — A. Mix one tablespoonful of flour, one of sugar,¹ and three-fourths of a yeast-cake to a smooth paste with four or five tablespoonfuls of cold water. Divide the mixture between three six-inch test-tubes (or three tumblers). Label the test-tubes *a*, *b*, and *c* respectively. Fill *a* with boiling water; half fill *b* with lukewarm water, and stand it in lukewarm water or in a warm place; half fill *c* with cold water and keep it at a temperature of 32° F. or below (by placing it in a bowl of cracked ice, or outside the window on a freezing day). In a fourth test-tube, *d*,

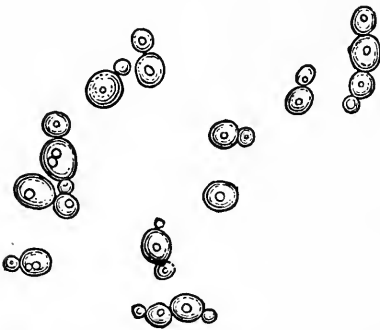

FIG. 9. — Yeast-cells.

put one-fourth of a yeast-cake mixed with water only; treat it like *b*.²

After fifteen minutes examine all four test-tubes. What do you see

¹ Adding sugar hastens the growth of the yeast; for bread-making the sugar in the flour is sufficient.

² A mixture of molasses and water may be used instead of a flour mixture in this series of experiments.

on the top of the liquid in *b*? What goes on in the liquid? Let *a* and *c* stand for a time where they will be about as warm as *b*; what change do you notice in either of them? Is there any foam on *d*? The quantity of foam produced is a measure of the vigor of the yeast. At what temperature does yeast thrive best? Will it grow at all at 32°? after being frozen and thawed? after being heated to 212°? Will it grow in water alone?

B. (To be done during the progress of Exp. A.) Prepare in a generating flask a mixture like the first used in Exp. A, using three or four times the quantity. Arrange an apparatus like that shown in Fig. 10. Or use test-tube *b* instead of a flask, standing it in a tumbler of warm water. What gas comes from the yeast mixture? In what other ways may this gas be produced? (pp. 107, 108.) What effect has it when introduced into batter or dough? As it is heavier than air, this gas may, with care, be poured into a tumbler from the bowl in which bread is rising, and tested by pouring lime-water into the tumbler.

Story of the yeast plant ; what it needs in order to grow. — Like mushrooms and other fungi (singular *fungus*) which have no green coloring-matter (*chlorophyll*), yeast needs no light; and like these, it grows and multiplies fast. It is like green plants in that it grows only when kept warm and moist. It thrives best at 78° F. It may be forced to grow and bud unnaturally fast by a higher temperature, just as hothouse plants are; but at about 130° F. it loses its liveliness, and by heat greater than this it is killed. Cold checks its growth, but even after being frozen it will,

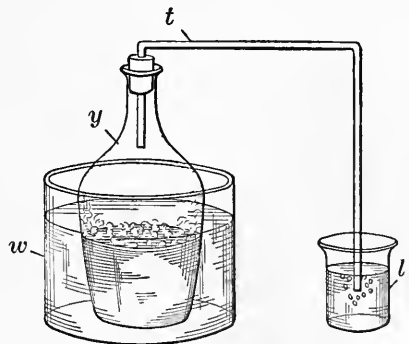

FIG. 10. — Apparatus for proving that growing yeast produces carbon dioxide.

y = flask containing yeast mixture.
w = vessel of warm water.
l = beaker containing lime-water.
t = glass tube.

if thawed, revive and grow. It needs water, and either protein, or some mineral matter containing nitrogen, to feed upon. Dried yeast-cells floating in the air revive if they fall where conditions are right for their development, and grow much as seeds do that fall on good ground. Floating spores develop into cells and grow and bud.

RECIPE FOR HOME-MADE YEAST

Flour, $\frac{1}{4}$ c.	Boiling water, 1 to 2 qt.
Sugar, $\frac{1}{4}$ c.	Compressed yeast, 1 cake, dissolved in 1 c. of water, or
Salt, 1 tb.	Liquid yeast, 1 c.
Raw potatoes, 3.	

Pare potatoes and keep in cold water. Mix flour, sugar, and salt in a large bowl, and grate the potato in as quickly as possible. Mix at once with a wooden spoon. Pour on boiling water directly from the tea-kettle, stirring constantly, until enough water has been added to make the mixture the consistency of thin starch. (If it does not thicken, heat it to the boiling-point.) Strain, and let it cool. When it is lukewarm, stir in the yeast. Beat well several times during the day. At the end of 24 hours, put it into earthen or glass jars, fasten the covers down tight, and put in a cool place. It will keep two weeks. Save the last cupful to start new yeast.

How yeast obtains oxygen. — A name meaning *sugar-fungus* has been given to yeast, because, while most vigorous when well supplied with oxygen from the air, it will, when sugar is at hand, take from this a part of the oxygen it needs. To get oxygen out of sugar, the yeast-cell digests the sugar

by means of a juice it secretes, which splits sugar into simpler compounds. The most important of these compounds are alcohol and carbon dioxide. This juice commonly acts inside the yeast-cell, but it can be extracted from yeast, and then acts on sugar as living yeast does.

Fermentation. — A chemical change of this kind, where one organic substance is decomposed by another, is called *fermentation*. The action of yeast in dough is an alcoholic fermentation of sugar.

Enzymes. — Fermentation is caused by substances called *enzymes*.

Other examples of fermentation of enzym action are the digestive processes in animals and plants, the souring of milk, the formation of vinegar. Enzymes come from living things, animals, plants, or minute forms of life such as yeasts and bacteria. Amylase, diastase, rennin, pepsin, and the milk-souring substance produced by lactic acid bacteria are all enzymes. (Pp. 70, 81, 86, 97, 99, 368.)

Cultivated yeasts. — Housewives and bakers used to grow yeast in a mixture of potatoes, sugar, water, and hops.¹ Such yeast cannot be as uniformly good as the pure yeast cultivated by brewers and distillers. Compressed yeast-cakes are made of fresh yeast skimmed from fermented distillery rye. It spoils quickly if not kept cold.

Dried yeast is made of fresh yeast mixed with starch and dried. It is used where fresh yeast cannot be obtained. It keeps for weeks, even months, but is best when fresh. Drying kills some of the yeast-plants; in time, all of them.

¹ Hops are used to check the growth of bacteria.

Dried yeast works slowly. Soak it in warm water with a little sugar and always set a sponge when using it for bread.

The yeast-garden. — Dough, after yeast is mixed with it, becomes a yeast-garden, which we must tend carefully in order to have a good crop of yeast and a plentiful yield of carbon dioxide. The water supplies moisture; the flour supplies sugar, which the yeast-plant, in its greed for oxygen, turns into alcohol and carbon dioxide. More oxygen is supplied by beating and kneading in air. The right temperature, 78° to 90° F., is insured by using lukewarm liquid and by keeping the sponge and dough warm until it is ready to be baked. What is the result? a dough expanded by bubbles of gas given off by the lively yeast-cells; a dough that has lost a little of its sweetness, but gained other pleasant flavors through various fermentative actions of the yeast on the flour.

After alcoholic fermentation has gone on for some time, another enzym begins to work on the alcohol, turning it into *acetic acid* (the acid found in vinegar). This is why dough sours if allowed to rise too long or at too high a temperature.

When the dough is just light enough,¹ it is put into an oven so hot that the yeast is quickly killed. Nearly all the alcohol is driven out of the bread as vapor during baking.

¹ Do not try to neutralize sour dough with baking-soda. Soda forms with acetic acid an unwholesome compound, and besides, since there is no way of knowing exactly how much acid has been formed, you are likely to use too much soda. Bread "sweetened" with soda is more unwholesome than bread a little sour.

HELPFUL HINTS ABOUT BREAD-MAKING

1. To keep the dough from cooling, mix and knead it quickly. In cold weather, warm the flour, the board, and the mixing-bowl.

2. The longer the batter is beaten, the less kneading the dough will require. When the dough can be lifted in a mass on the spoon, it is ready to knead.

3. We knead bread (1) to mix the ingredients thoroughly, (2) to make the gluten elastic, and (3) to work in air. Dough is sufficiently kneaded when it can be left on the board for a minute or more without sticking. Use as little flour as possible.

4. By using not less than one yeast-cake to one pint of liquid the following advantages are gained: (1) The bread can be made and baked within five hours. (2) It may more easily be kept clean and free from kitchen odors than if it stood longer. (3) It has not time to sour.

5. If you are unable to attend to the dough as soon as it is risen, it may be cut down (*i.e.* scraped away from the sides of the bowl and pressed over into the centre) and allowed to rise again.

6. Dough that contains large bubbles has risen too fast or too long. It should be cut down and rekneaded to distribute the gas evenly. Sour dough falls in the middle, is stringy, and smells and tastes acid.

7. Use round or French bread-pans; in the corners of rectangular pans the dough has not room fully to expand. Make small loaves always, to insure the bread's being baked

through. If obliged to use pans more than four inches broad, bake the bread from one hour and a quarter to one hour and a half, decreasing the heat after the first half hour. Why should it be decreased?

8. If bread rises much after being put into the oven, the heat is not great enough; if it begins to brown in less than fifteen minutes, the heat is too great. If the loaf rises or browns more on one side than on the other, turn it around.

9. The crust, by preventing the inside of the loaf from drying, keeps the centre from becoming hotter than about 212° F. Which is more digestible, crust or crumb? Why?

10. Bread is baked when it shrinks from the sides of the pan. To make the crust crisp and tender, rub it while hot with a bit of butter twisted in a piece of cloth or paper. Set fresh loaves on edge in such a way that air reaches all sides of them. When cool put them in a tin box or stone jar. Do not wrap bread in cloth. If it tends to dry quickly, wrap it in waxed paper.

Uses for stale bread. — Stale bread, if heated in a closely covered pan, becomes almost like new. Keep pieces of stale bread by themselves in a jar or covered bowl. Stale slices may be used for toast. (See directions for toasting bread, p. 89.) Dry broken pieces in a warm oven until they are crisp, but not brown. Grind them, or crush them on a board with a rolling-pin kept for this purpose; sift the crumbs, and keep them in a jar to use for croquettes, etc. They will keep several weeks. Coarser or browned crumbs may be used for the tops of scalloped dishes. Stale crumbs not dried are suitable for bread puddings, and filling of

scalloped dishes. Bread dried slowly in the oven till brittle and brown all through is liked by many people and is excellent for children.

PARKER HOUSE ROLLS

Flour, 4 c.	Compressed yeast, 1 cake, mixed
Salt, 1 t.	with
Butter, 2 tb.	Lukewarm water, $\frac{1}{4}$ c.
Scalded milk, 1 c.	Sugar, 1 tb.
	Extra butter.

Reserve one-half cupful of flour. Pour the hot milk on the salt, sugar, and butter. When it has become lukewarm, stir into it the yeast and add the flour gradually, using as much of the reserved portion as is necessary. When stiff enough, knead the dough on a board. Let it rise until tripled in bulk. Roll out about one-half inch thick, cut with a biscuit-cutter, spread lightly with melted butter, crease with the back of a knife-handle dipped in flour, and fold almost double. Let the rolls rise until doubled in bulk (about twenty minutes). Brush them with water or milk, and bake in a very hot oven fifteen minutes.

SWEDISH ROLLS

Flour, about 4 c.	Compressed yeast, 1 cake, mixed with
Sugar, 2 tb.	Lukewarm water, $\frac{1}{4}$ c.
Salt, $\frac{1}{2}$ t.	Eggs, 2.
Butter, 2 tb.	Currants, about $\frac{1}{2}$ c.
Scalded milk, 1 c.	Extra butter and sugar.

Put sugar, salt, and butter in a bowl. Pour upon them the hot milk. When the milk has become lukewarm, stir

in the yeast. Add enough flour to make a drop-batter, beating till full of bubbles. Let it rise until very light. Add the beaten eggs, beat well; add enough more flour to make a soft dough, knead thoroughly, and let it rise again. When tripled in bulk, roll out, with as little handling as possible, into a rectangle a little less than one-half inch in thickness; spread thinly with softened butter, working from the centre toward the edges. Sprinkle with currants and sugar. Roll the dough up into a cylinder one inch in diameter, and cut it into slices one inch thick. Place these close together, cut side down, on shallow greased pans, and let them rise till very light. Dissolve one teaspoonful of sugar in two tablespoonfuls of milk; brush the tops of the rolls with this mixture, and bake them twenty minutes in a hot oven.

Preparing currants. — Cleaned currants in packages need only be picked over. To clean currants bought in bulk, sprinkle them with flour and rub between the folds of a clean cloth, pick off stems, rinse currants in a wire strainer until the water comes through clean, shake to remove water, and dry in the sun, or in a warm, *not hot*, oven.

Kinds of bread and their food value. — Bread of one kind or another is in common use the world over. Wheat bread meets the needs of the body more nearly than any other kind does. About half the dry matter of wheat bread is starch. Bread contains some fat, and enough protein and mineral matter to give it value as a tissue-builder. To people among whom it is the chief article of diet, its tissue-building material is of first importance. By those who eat con-

siderable meat or other protein food, bread is valued more for its starch and other non-nitrogenous foodstuffs. (Chart 4.) Graham and whole wheat breads contain and supply to the body more mineral matter than white bread, but do not supply more protein as some people suppose. For brain workers and inactive people coarse breads are good because the bran in them gives bulk and tends to promote intestinal activity.

Digestion of bread. — Try to crumble fresh bread, stale bread, bread-crust, soft toast, crisp dry toast. Which crumble more easily? Which will be most readily broken up by the teeth? Well-chewed bread tastes better and satisfies hunger more quickly than bread swallowed hastily.

Chewing helps to dissolve food, and by exciting the nerves communicating between the mouth and other digestive organs, it starts a flow of digestive juices toward the stomach and intestines. Where is starch digested? where is protein digested? What digests them? (Pp. 70, 86, 369.)

Should we buy bread or make it? — The best home-made bread is cheaper, more nutritious, and more wholesome than bought bread. The process of bread-making is not so difficult as many people suppose. The yeast now obtainable is excellent in quality; and, by our knowledge of the effect of different temperatures upon it, the length of time consumed by the rising process may be lengthened or shortened at will. By placing the bowl of dough in warm water the time required for rising may be known with exactness, thus lessening the necessity for constant watching.

“Home-made” is the standard by which the quality of baker’s bread is judged. Much may be learned from some of our foreign citizens, notably the Italians, who use a good bread flour, knead well, thus making a close bread, and bake it thoroughly. Italian bread, both baker’s and home-made, especially that made by Sicilians, is among the best in the world.

Some people have neither time nor a good place for making bread, and it is important that bakeries be so regulated and inspected that clean and good bread can be bought.

BRIEF REFERENCE LIST

For further development of topics treated in this section see:—

CONN: *Bacteria, yeasts, and molds in the home.*

BUCHANAN: *Household bacteriology.* Ch. 25.

GRANT: *Chemistry of bread-making.* Ch. 9.

BIGELOW: *Applied biology.* Pp. 268–276, Yeast-plants.

NATIONAL GEOGRAPHIC MAGAZINE: *Making bread in different parts of the world.* V. 19, 1908, no. 3, pp. 165–179. Illust.

U. S. DEPT. OF AGRICULTURE: BUREAU OF CHEMISTRY. Bulletin 164. Graham flour.

U. S. DEPT OF AGRICULTURE: *Farmers’ bulletin* 389. Bread and bread-making.

CHAPTER V

FOOD IN ITS RELATION TO LIFE

SECTION 1. BODYSTUFFS AND FOODSTUFFS

Body, organs, tissues, cells. — The body of a human being, like the bodies of most animals and plants, consists of parts called *organs*. The special work of each organ is called its *function*. What is the function of the eye? of the lungs? of the stomach? of a root? of a leaf? Organs differ from one another, not in function only, but also in make-up, or structure. The various kinds of material composing the organs of the body are called *tissues*. Bony tissue is found in bones and teeth, muscular tissue in muscles, and nervous tissue in nerves and brain. The tissues of the body are made up of *cells*, as the walls of a house are constructed of bricks. Instead, however, of being laid together, as bricks are, these cells grow together, each kind of tissue being built of similar cells of a particular kind.

Cells in the body not all alike. — One yeast-cell is much like another, but how about the cells in a grain of wheat? Starch-cells differ from bran-cells in structure because they differ in function. Each yeast-cell is independent, doing all its own work; but in higher forms of life, both plant and animal, where many cells are joined together in one individual, some have one function, some another. We may

compare a yeast-plant to a man living alone, preparing his own food and making everything he needs, while a tree or a horse or the body of a human being is like a nation, in which some men are farmers, some manufacturers, some merchants, and so on. And just as the merchant does not understand farming, nor the man who raises wheat know how to make it into flour, so a cell of one kind cannot do the work of another. Cells in lung tissue, for example, are adapted for absorbing oxygen, and cells in the retina of the eye for receiving rays of light; but neither kind of cell is able to take in food until it has been prepared for them by the work of other cells. (Chap. 15.)

Protoplasm. — All living cells have for their basic substance a very thin translucent jelly. This is protoplasm, the only thing in plants and animals that is really alive. The meaning of the word protoplasm is *first-formed*, or *first-created*.

Foodstuffs. — Food contains five different classes of foodstuffs: protein, fat, carbohydrate, mineral matter, and water. Any food must contain at least one of the first four. We already know that protein builds tissue, and that fat, carbohydrate, and protein all are burned to supply energy, giving out heat in the process. (Pp. 71, 86.) The value of any food as an energy-producer is called its fuel value. The mineral part of food is often termed ash, because it is left, when all the rest of the food, even the carbon, is burned up. As this plainly shows, mineral matter has no fuel value, but it helps to build tissue. The organic acids in fruits and fermented foods have fuel value, though not so much as carbohydrates

have. Water cannot be said to build tissue, but it keeps up the supply of water in both the tissues and the fluids of the body. Both water and mineral matter have a special work to do in keeping all tissues and fluids in healthy condition, and in taking an essential part in digestion and the various other processes which go on in the body.

The special value of protein. — Protoplasm cannot be made without protein, because only in protein is nitrogen found combined in a certain way with carbon, hydrogen, and oxygen. Plants draw up other nitrogen compounds from the soil and turn them into protein; but animals and man must obtain protein ready-made in their food. Therefore we require a certain amount of protein food, no matter how well supplied we may be with other foods. Proteins differ according to the way in which the elements in them are arranged. There is one kind of albumin in eggs, another in milk, another in meat. Some proteins contain, besides the five elements already mentioned, iron or phosphorus or both.

Proteins are not all equally good tissue-builders. The proteins of eggs and milk are among the best. Gelatin, found in cooked meat, and zein, the chief protein of maize, are among the poorest. Tissue cannot be built from either gelatin or zein alone. Indeed, proteins seem to build better when they work together. For this reason there is sense in our practice of using a variety of protein foods.

The special value of carbohydrate and fat. — Although protein supplies both building-material and fuel, so that in theory one might live upon protein (with water and mineral

matter), it is more economical and in the long run more healthful to depend largely upon fat and carbohydrate for fuel. (Which kinds of food, generally speaking, are the most expensive, animal or vegetable? From which do we get most of our carbohydrate?) Any fat not used at once for fuel may be stored in the body until needed. A layer of fat under the skin protects against cold. As a rule carbohydrates are rapidly used up in producing energy, but they can be changed into fat and stored. Starch and sugar are the most abundant of carbohydrates. Dextrin occurs in smaller quantities. Glycogen is an animal carbohydrate something like dextrin. It is stored as reserve fuel; in men and animals mostly in the liver, but in shellfish more generally throughout the tissues.

The importance of mineral matter. — The ash from a mixture of foods contains iron, sulphur, phosphorus, potassium, sodium, and other elements, mostly in the form of mineral salts. The only mineral salts not entering the body as a part of some food are common salt (sodium chloride) and the salts in mineral waters. Some of the salts in food are simply dissolved in animal fluids or plant juices. Others are joined to proteins. All of these elements are essential to healthy life, and as one element cannot take the place of another, it is important to eat a sufficient variety of food to supply them all. If we eat enough protein, we shall obtain all the sulphur we need, but we are not sure of getting enough iron or phosphorus. Lack of phosphorus is as harmful as lack of protein, phosphorus being necessary to many tissues, particularly to the brain and nerves. Phos-

phorus is supplied by milk, eggs, certain vegetables, and by cereal foods which include part at least of the outer layers of the grain, such as whole wheat and natural brown rice. Calcium gives hardness to bones and teeth. Calcium salts are plentiful in milk and cheese. Iron makes good red blood. There is much iron in lean meat, but it is found in a more nutritious form in milk, eggs, cereals, vegetables, and fruits. Salts also help to regulate digestion, circulation, and other body-processes.

Acid-forming and base-forming foods.— Acid and alkali neutralize each other in the body as they do in baking-powder. (P. 109.) The alkalies found in the body have another name, *bases*. An excess of acid is not good for the health. An excess of bases does no harm. So we should eat enough base-forming foods to neutralize the acid present, or even a little more. At this point we have something unexpected to learn. The acids of fruits and vegetables do not remain acid in the body. They are changed into bases. The acids derived from food come from protein. (P. 370.) This may sound confusing; but what we need to remember is simple. *Meat, eggs, fish, and milk are acid-forming foods. Fruits and vegetables are base-forming foods.* We should eat liberally of fruits and vegetables to neutralize the acid from protein foods. This gives us a second reason for eating potato with meat. What other reason is there?

The three functions of food.— What we have learned makes it plain that the functions of food are: (1) to furnish energy, including heat, (2) to build tissue, (3) to regulate body-processes.

Waste in food. — Food as purchased contains some uneatable material, *inedible* it is termed, such as egg-shells, pea-pods, bones. Other portions of the food, often considered waste, may be utilized. For example, fruit-parings may be made into jelly, meat-trimmings and celery-root used for soup.

Food-adjuncts are materials added to food for the sake of their flavor or their stimulating effect on taste, appetite, or digestion. They include condiments, such as spices, pepper, and vinegar; herbs; onion-juice and other vegetable flavorings; and the oils of the vanilla bean, of lemon, and of other fruits and some nuts. Salt and sugar are used as food-adjuncts as well as foods.

Beverages include drinks of all kinds. Tea, coffee, and cocoa are treated of in Chapter XII. Beverages made with unfermented fruit-juices (fresh or preserved) are wholesome, and might well be more generally used in the home.

Alcoholic liquors (rum, whiskey, gin, brandy, wine, beer)¹ are made of the fermented juices of fruit or grain. (See pp. 130, 131.) They contain too little food material to be worth anything as food. Instead of satisfying hunger, alcohol produces an unnatural craving. In spite of the feeling of warmth it gives, it tends to lower the temperature of the body. It impairs the ability to work. It makes workmen careless and liable to accidents. It builds no

¹ Brandy, rum, and whiskey usually contain from 40 to 50 per cent of alcohol, gin somewhat less. Wine contains from 7 to 16 per cent, beer usually 3.5 to 4 per cent of alcohol. Wine and beer drinkers, however, may drink such large quantities of these beverages that they get a great deal of alcohol. Root-beer made with yeast contains alcohol.

tissue. On the contrary it injures tissue, particularly that of nerves and brain. It is unnecessary and so harmful that in a considerable part of the United States the sale of liquor is prohibited by law.

Valuable properties of fresh foods. — It has been found that people cannot keep healthy indefinitely on dried, canned, or otherwise artificially prepared foods, even though they contain all the foodstuffs. We need to have some of our food in its natural state, fresh, or even raw. It is supposed that fresh food, both animal and vegetable, contains minute quantities of substances, not nutritious in themselves, but essential to nutrition, and that these are affected by heat, and destroyed by prolonged cooking or drying. These substances have been named *vitamines* and *lipoids*.

BRIEF REFERENCE LIST

For further development of topics treated in this section see :—

SHERMAN : *Chemistry of food and nutrition*.

SHERMAN : *Food products*. In particular ch. 1.

KINNE AND COOLEY : *Foods and household management*. Ch. 18.

HUTCHISON : *Food and the principles of dietetics*. Especially ch. 9, Alcohol.

GREER : *Food — what it is and does*. Pp. 178–216.

CHITTENDEN : *Nutrition of man*.

STILES : *Nutritional physiology*. Ch. 24, Alcohol.

OLSEN : *Pure foods*. For condiments and spices see ch. 17 and 18.

MENDEL : *Nutritive significance of different kinds of foodstuffs*. Medical record, v. 85, no. 17, 1914.

U. S. DEPT. OF AGRICULTURE : *Farmers' Bulletin*. 142. Principles of nutrition.

SNELL : *Elementary household science*. Ch. 31–36.

RITCHIE: *Primer of physiology.* Ch. 1 and 2, The human body and the cells of which it is built.

BIGELOW: *Applied biology.*

CHITTENDEN: *Nutrition of man.*

SECTION 2. DIET

Food requirements.—We eat not merely to keep our bodies alive, but to make them as fit as possible to serve us in all the activities of life. Food requirements vary with age, work, climate, and other conditions. Attempts have been made to fix dietary standards, that is, to determine the exact amounts of each class of foodstuffs required daily by a person of given age, weight, and habit of life. As a result of these and other dietary studies, certain facts are known which should guide us in selecting our own diet or in providing a diet for others.

Most of our food is used as fuel for the production of energy. Fuel value is measured in units called *calories*.

A calorie is the amount of heat required to raise 1 kilogramme of water 1° Centigrade, or 1 pound of water about 4° Fahrenheit, or if expressed as work, the energy required to raise a 1-pound weight 3087 feet.

Protein and carbohydrate have about the same fuel value; fat has a fuel value a little more than twice as great as either protein or carbohydrate. The food eaten each day, often termed the daily ration, should include carbohydrate, protein, and fat. As fuel these foodstuffs can to a certain extent take the place of one another; but the fuel value of all three together must be sufficient to furnish the required heat and energy. The amount of protein not used for fuel, but

for the repair, and in young people for the growth, of living tissue, is also measured in calories.

Calculation of dietaries. — The fuel value or energy value of all foods in common use has been ascertained by burning weighed portions of them and measuring exactly the amount of heat given off by each. Tables have been prepared stating these fuel values in calories. Other tables have been made showing just how much by weight and by measure of any kind of food is required to furnish 100 calories. With the aid of these tables and scales to weigh food, we can learn to calculate the fuel value of a dish or of a meal, and to plan a meal or a dietary for a day or a week that shall provide one person or a family with the number of calories to meet its needs. Of course, people of different ages and degrees of activity require different numbers of calories, a grown person more than a child, but a child more in proportion to its weight than a grown person. These varying requirements have been worked out and tabulated.

PRACTICAL POINTS ABOUT FEEDING A FAMILY

1. Brain workers (teachers, students, clerks, etc.) need easily digestible food; muscle workers (working-men, etc.) find coarser food better suited to their needs.

2. No one meal need provide the different foodstuffs in any given proportion, but 10 to 15% of the total calories in each day's food should come from protein.

3. Diet should be varied as well as mixed. To vary the diet is the surest way to make it wholesome. The more kinds of foods we eat, the more likely we are to obtain all the kinds of foodstuffs, particularly all the kinds of mineral matter, that we need. A varied diet does not mean many

dishes at one meal. A boarding-house table which offers many different foods each day, but practically the same bill of fare week in and week out, is pretty sure to be deficient in some foodstuff or element. A rightly varied diet changes from week to week and with the season.

4. When planning a meal, think what was served at the preceding one; if starchy foods chiefly, supply plenty of protein. Do not forget that butter, eggs, milk, etc., used in cooking count as food just as much as if served by themselves on the table. By planning meals, in part at least, for several days ahead, you will find it easier to provide varied and rightly balanced fare.

5. Food is not necessarily nutritious in proportion to its cost. (See *Economy in Marketing*, p. 183, and *Selecting Vegetables*, p. 243.)

6. Remember that plant protein may to some extent take the place of animal protein; if you have but a small piece of meat, serve peas or beans with it rather than beets, p. 238.

7. Familiarize yourself with the composition of common foods so that you may readily think of suitable combinations and know how to supply lack of one food by another of similar character.

BRIEF REFERENCE LIST

For further development of topics treated in this section see:—

SHERMAN: *Chemistry of food and nutrition*.

RITCHIE: *Primer of physiology*. Ch. 18, Foods and health.

BARROWS: *Principles of cookery*. Pp. 133–139 and 170–180, Menu making.

- TERRILL: *Household management*. Pp. 127-163, Marketing.
- KINNE AND COOLEY: *Foods and household management*. Ch. 17 and 18.
- ROSE: *Laboratory handbook for dietetics*.
- RICHARDS: *The cost of food*.
- KERLEY: *Short talks to young mothers*.
- KERLEY: *Nutrition of school children*. (Teachers College Record, March, 1905.)
- JACOBS: *Menu-making and the nutritive value of meals*. (Journal of Home Economics. V. 6, no. 1, Feb. 1914.)
- COLWELL AND WELLMAN: *Use of Fisher's 100-calorie portion*. (Journal of Home Economics, Dec. 1910.)
- CHITTENDEN: *Nutrition of man*.

CHAPTER VI

MEAT, FISH, AND POULTRY

SECTION 1. MEAT: ITS STRUCTURE, COMPOSITION, AND COOKING

Although in different parts of the world the flesh of many different animals is used for food, we depend mostly upon that of cattle, sheep, and hogs. The flesh and certain edible organs of these animals constitute our meat. The term *meat* may be used to include fowls. Beef is the flesh of mature cattle, veal that of calves. Mutton is the flesh of mature sheep, lamb that of young sheep. The flesh of hogs is sold fresh as pork, smoked as ham and bacon.

A STUDY OF THE STRUCTURE AND COMPOSITION OF LEAN MEAT

A. Examine a piece of round of beef, noting its fibrous appearance. Can you see any fat among the fibres? Scrape with a knife first one side, then the other, of one of the pieces of meat from which the juice has been squeezed, until only the fibres are left. Pick some of them apart with a needle. Try to break or tear them.

B. Heat the mass of fibre, and note the effect.

Structure of meat (muscular tissue).—Each fibre is a bundle of tube-shaped cells covered and bound together with a web of white connective tissue, threaded by tiny blood-vessels. Toward the ends of the muscles the fibres

dwindle down till only a firm mass of connective tissue, called tendon, is left. The contents of the tubes and blood-vessels may be scraped out, leaving these, with the connective tissue, in a pale-colored, stringy mass.

Directions for making raw beef sandwiches (for invalids).

— Cut juicy, lean beef into thin strips. Scrape the pulp from them, season it highly with salt and pepper, and spread between *thin* slices of bread.

What two animal foods have we already used and studied? What important foodstuff have we found in both of these? (Pp. 88 and 95.) How can we find out if it is also in meat?

Experiments. — **A.** Dry some meat slowly for several hours. Heat a little of it in a test-tube with lime. What odor do you notice? What foodstuff is present?

B. Nitric acid test for protein. **Caution.** — *This test must be made only by the teacher or some person experienced in handling chemicals. Nitric acid is a dangerous fluid.* Put a few bits of meat into a test-tube with a little water. Add a few drops of nitric acid. Boil two or three minutes. A bright yellow color appears. Let cool and add a few drops of ammonia. The color turns to deep orange.

Any food material may be tested in this way for protein. To test raw white-of-egg, cut it with scissors until half a teaspoonful can be taken up. Put this in a test-tube, and add the nitric acid.

Directions for extracting beef-juice. — Use a one-half pound slice of the top round of beef cut three-fourths of an inch thick. Place it in a wire broiler. Sear both sides quickly, turning it frequently until it swells and becomes spongy. Cut it into small pieces. Squeeze these, a few at a time, in a meat press, vegetable press, or lemon squeezer. Half a pound of meat should yield two ounces of juice.

Beef-juice is sometimes prescribed for invalids. (For directions for serving it see p. 334.)

Experiment C. — Heat beef-juice in a test-tube. Note that flakes form in it, and that the red color disappears.

Composition of meat. — Lean meat contains albumin dissolved in much water. It also contains other proteins some of which are not soluble in water. There are also present small amounts of other nitrogenous substances, not proteins, called extractives. Practically all the proteins are coagulated by heat. Also in solution are various mineral salts. The red color of meat, which is destroyed by heat, is due to iron salts in the blood.

Connective tissue consists largely of collagen. Heat causes collagen to swell and force the juice out of the muscle fibres. In preparing beef-juice, the object is to heat the meat just enough to express the juice, but not enough to coagulate the protein in it. A mass of connective tissue, as a whole, shrinks when heated, owing to loss of water. Dry heat both shrinks and hardens it.

Directions for preparing beef-tea. — Cut into small bits one pound of beef from the top round. Put it in a glass jar, sprinkle with salt, put on the cover, and set the jar, wrapped in cloth, or supported on a trivet, in a kettle of cold water. Heat the water till it steams, and keep it as near this same temperature as possible until the meat is colorless and the juice looks rich and thick. Do not strain.

If the beef-tea could be kept at just the right temperature, the proteins would remain dissolved. This can hardly be

U. S. Department of Agriculture
Office of Experiment Stations
A. C. True: Director

Prepared by
C. F. LANGWORTHY
Expert in Charge of Nutrition Investigations

COMPOSITION OF FOOD MATERIALS.



LAMB CHOP
EDIBLE PORTION

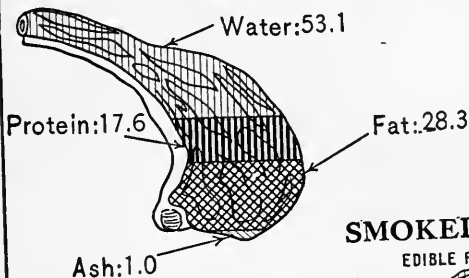

PORK CHOP
EDIBLE PORTION

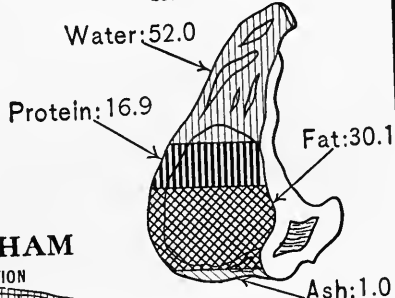

SMOKED HAM
EDIBLE PORTION

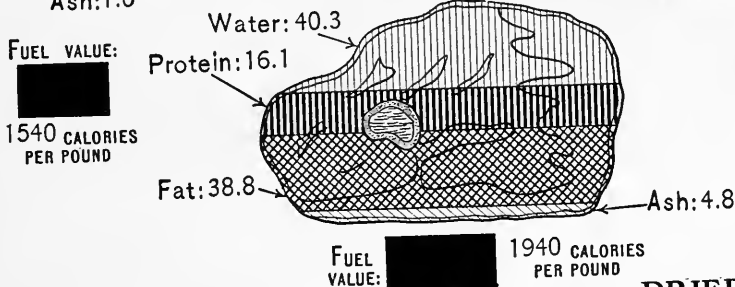

FUEL VALUE: [Solid black] 1580 CALORIES PER POUND

BEEF STEAK
EDIBLE PORTION

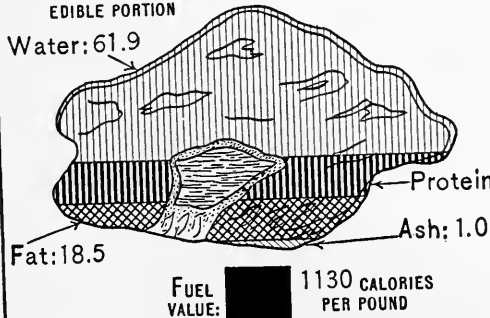

DRIED BEEF
EDIBLE PORTION

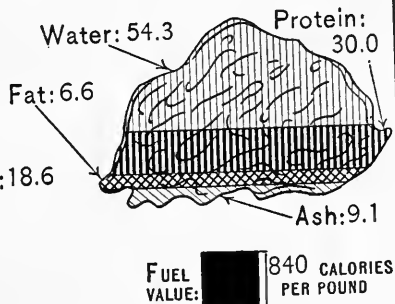

CHART 5.

accomplished, however. If, therefore, the tea should be strained, it would no longer be nutritious, though the extractives remaining in it would give it a strong meat flavor.

Experiments showing the action of cold water and of salt upon meat. —

A. Cover a bit of raw meat with cold water, and observe how quickly the water becomes red. What does this show? Is anything besides blood drawn out? **B.** Filter the water through filter-paper and heat the filtrate; *i.e.*, the liquid that passes through. Has any albumin dissolved in the water? **C.** Sprinkle a bit of raw meat with salt. What does the salt do to the juices of the meat? How do these afterward act upon the salt?

What conclusions do you draw from these experiments with regard to (1) putting meat into water to wash it, and (2) salting meat before cooking it?

Care of uncooked meat. — As soon as meat is brought into the house, take it out of the wrapping-paper, wipe it with a damp cloth, cut out any part discolored by a meat-hook, and set it away in a cool place.

Reason for cooking meat. — Meat is cooked, not to make it more digestible, but chiefly to improve its flavor, and to soften the connective tissue.

HOW TO COOK TENDER MEAT: BROILING, ROASTING, BOILING

When the whole piece of meat is to be eaten, we desire so to cook it as to retain all the juice. This is done by exposing it for a short time to heat intense enough to harden the albumin on its surface, thereby sealing up the juices inside, and then for a longer time to a lower temperature, to com-

plete the cooking of these juices. Can you think of two reasons for not cooking it at a high temperature all the time? Should you choose a thick or a thin piece of meat for broiling? Why? One with much or little connective tissue? Why?

Meat: tough and tender. — Meat, to be wholesome, must come from a healthy animal; to be nutritious, from a well-nourished one. Much-used muscles absorb much food material, making rich, juicy meat. This is, however, tougher than that of parts less used, because the connective tissue and fibre increase as well as the contents of the muscle-tubes. In which parts of the ox or sheep should you expect to find tender meat? in which parts tougher, juicier meat?

How to know good beef. — The lean of good beef is firm, elastic, and, when first cut, purplish red, the surface becoming bright red and moist after exposure to the air. The tenderer cuts are fine-grained and well-mottled with fat; a thick layer of firm, light straw-colored fat extends over the rib and loin cuts; the kidney suet is white and crumbly. Flabby, dark, or coarse beef with yellow fat is poor; if it has little fat, it is from an old or under-fed creature.

The characteristics of good mutton and lamb are similar to those of good beef, excepting that the lean is lighter-colored, and the fat whiter.

The best cuts for broiling are steaks from the loin of beef (short, porter-house, and sirloin), and rib or loin chops of mutton and lamb. (For other broiling pieces, see table, pp. 186-193.)

DIRECTIONS FOR BROILING BEEFSTEAK

Time. — For a steak one inch thick, five or six minutes; one and one-half inches thick, eight to ten minutes. (Never cut steak into small pieces.)

Steak properly broiled is puffy from the expansion into steam of the imprisoned moisture, well browned on the outside, and juicy and red, without being purplish, to within one-eighth of an inch of the surface. Steak less than one inch thick loses so much water by evaporation that the inside is dry before the outside is brown.

(1) **To broil by coal.** — Put a platter to warm before beginning to broil the steak. Have the coals glowing hot, without flame or smoke. Grease a double broiler with beef fat, place the steak in it, and hold it near the coals while counting ten slowly. Turn the broiler, and hold the other side down for the same length of time. Continue to turn the meat about once in ten seconds for about one minute, or until it is well seared; then hold it farther from the fire, turning occasionally until the surface is brown.¹ Just before taking it from the fire sprinkle with salt and pepper, turning each side once more to the heat to cook the seasoning in. When the steak is cooked, lift it on to the platter, spread both sides with butter, or with Maître d'Hôtel butter, garnish, if you like, with water-cress and slices of lemon, or with parsley, and serve without delay.

(2) **To broil by gas.** — Have the broiling oven hot. Lay

¹ Reasons for turning the meat: 1. To prevent the escape of juice. The meat must be turned just before the juice forced out of the tissues nearest the heat begins to escape from the upper side; if it overflows, it will drip and be lost. 2. To insure even cooking.

the meat in a double broiler or directly on the rack over the pan. In the latter case turn the meat with two spoons to avoid piercing it. Proceed as in broiling over coals, except that the meat requires turning only three or four times. Keep the door open (p. 15). Turn down the gas and lower the pan, if necessary, after the meat is seared.

Lamb and mutton chops are broiled like beefsteak, allowing six to eight minutes, according to thickness. Mutton chops may be slightly red in the middle; lamb chops are usually preferred less rare. Tomato sauce or green peas may be served with chops.

Pan-broiling. — Meat cooked on a pan may be almost as well-flavored and juicy as broiled meat, if properly done.

Use a cast-iron, not a sheet-iron, pan, and let it become almost red-hot before putting the meat in. Rub it lightly with a bit of fat from the meat, let the meat lie on one side till seared, then turn it, and continue turning it occasionally until done. If melted fat collects in the pan, pour it off. Season and serve like broiled meat. Turn chops on edge for a few moments to brown the fat.

Is pan-broiling the same as what is commonly called "frying"? Why not? What objection is there to "frying" meat and other albuminous foods? Are griddle cakes "fried"? (Methods of cooking, p. 49.)

MAÎTRE D'HÔTEL BUTTER

Butter, $\frac{1}{4}$ c.

Pepper, f.g.

Lemon-juice, 1 tb. sc.

Parsley, cut fine, 2 t.

Salt, $\frac{1}{2}$ t.

Cream the butter and stir in the other ingredients.

TOMATO SAUCE (FOR MEAT)

Tomato, 1 pt.	A sprig of parsley.
Chopped onion, 1 t.	Butter, $\frac{1}{4}$ c.
Whole cloves, 2.	Flour, $\frac{1}{4}$ c.
A bit of bay-leaf.	Salt, 1 t.
Pepper, $\frac{1}{8}$ t.	

Cook the first five ingredients together for about ten minutes. Mix the others in a saucepan and strain into them the tomato mixture. Cook, stirring, till the sauce boils.

Which is the largest, a short-steak, a porter-house, or a sirloin? Observe that each contains one-half of one of the bones of the spine (*vertebræ*, plural), and that between this bone and the kidney fat lies the tenderest part of the steak. These tender parts are sections of the *tenderloin*, a little-used muscle which extends along the spine from the rear-most rib to the hip joint, being thickest near the forward end of the hip-bone, where hip-bone sirloin steaks are cut.

Beef grows tougher and coarser the farther down it lies on the flank. Which of the three loin cuts of steak has most flank? Flank ends of steak should be trimmed off and used for soup or stew. Why not broil them? Compare sirloin or porter-house steak with a lamb or mutton loin chop. Find in both the spinal vertebra, tenderloin, outside fat, kidney fat, and flank. Compare a rib chop with the cut of beef called prime roasting ribs. What advantage have loin over rib chops? (See Plates X and XI.)

For roasting,¹ as for broiling, tender cuts are best. Sir-

¹ To roast meat, properly speaking, is to cook it before an open grate, a method superseded in this country by "oven-roasting," which is really baking.

loin and porter-house roasts are compactly rolled; rib pieces may be either roasted whole, forming a standing roast, or boned and rolled. Leaving in the bones improves the flavor, but the thin end of a standing roast is likely to be overdone by the time the thick end is sufficiently cooked.

DIRECTIONS FOR ROASTING BEEF

Time. — Ten or twelve minutes to the pound. The smaller the piece of meat the longer the time per pound.

In properly roasted beef, the outside fat is brown and crisp, the lean brown to a depth of not more than one-fourth of an inch, the interior evenly red and full of juice.

Have the oven at first as hot as for bread.¹ Skewer or tie the meat into compact form, place on a rack in a pan with the skin side down, and dredge meat and pan with flour. In the pan put one tablespoonful of salt and one-fourth teaspoonful of pepper. If the meat is very lean, put a few bits of fat in the pan. When the beef is seared and the flour brown, reduce the heat, and baste the meat; that is, dip over it the melted fat from the pan.² Baste about once in ten minutes until done. After half an hour turn the roast over to brown the skin side.

To make brown gravy. — After removing the roast to the plate, take out the rack and pour or skim off most of the fat from the liquid in the pan. Set the pan on the stove, and

¹ The smaller the roast the hotter should be the oven. It is well to sear a small roast by holding each part of its surface in turn on a hot frying-pan; if this is done, less heat is required in the oven.

² Reason for basting. — The fat and flour, aided by heat, form a crust, imprisoning the juices of the meat, and preventing the lean from charring.

dredge into this liquid about three tablespoonfuls of flour. Add one and one-half cupfuls of boiling water, and boil five minutes, stirring. Taste to see how much salt and pepper is required, add these, and strain into a gravy boat. (Browning of flour, p. 69.)

Experiment to show the effect of cold and of hot water upon meat. — Into each of two test-tubes put two bits of meat of the same size. Cover one with cold water, the other with hot water, and boil the latter for two or three minutes. After letting both stand for ten or fifteen minutes, observe (*a*) differences in the appearance of the bits of meat, (*b*) in the appearance of the water in the two test-tubes. Which piece of meat has lost the most juice? Explain why.

Should the cooking water for meat be cold or hot when the meat is put into it? Why? How may we contrive to retain the juice and yet not overcook the meat? Is it strictly correct to call meat properly cooked in water "boiled" meat? Which is higher flavored, roasted or so-called boiled meat?

The great heat to which meat is exposed in broiling or roasting decomposes some of its constituents, producing new compounds of richer flavor. A temperature of 212° F. being too low to produce these chemical changes, the flavor of meat cooked in water is, by comparison, insipid.

DIRECTIONS FOR "BOILING" A LEG OF MUTTON

Time. — Fifteen minutes to the pound.

Cover the leg of mutton with boiling water, let this come to the boiling-point again, and boil five minutes; skim off the coagulated albumin ("scum"); then simmer until

the meat is tender. Serve with Caper Sauce, made by adding one-half cupful of capers, drained, to one and one-half cupfuls of Drawn Butter (recipe on p. 204) made with the mutton liquor.

Salt meats. — Corned beef, ham, and tongue, which are better for having some of their salt drawn out, should be put to cook in cold water. After this boils, follow the directions for cooking a leg of mutton.

The taste of water in which meat has been cooked shows that some of the meat has escaped into it; save it, therefore, to use in soup-making. Can we use the cooking water from salt meat for soup?

USES FOR THE GELATINOUS PARTS OF MEAT: SOUP-STOCK AND SOUPS

Soup an economical dish. — Soup, by some people mistakenly thought to be an expensive luxury, is generally a means of economy, since a soup, tempting and nutritious, can be made of the cheapest materials, including remnants of food unfit for other use. Economy means *management*, not *saving* merely, though sometimes wrongly understood in the latter sense. Good economy includes wise spending and using; it is as wasteful to broil meat too tough to be chewed or digested as it would be to throw away meat that might be used; it is as prudent to purchase a small quantity of vegetables and seasonings, which will help to make a savory soup or stew out of material useless by itself, as to refrain from buying something not needed.

Soup-stock. — Soup-stock is the basis of all meat soups. It consists of the soluble portions of meat, vegetables, and sometimes other ingredients dissolved in water.

DIRECTIONS FOR MAKING SOUP-STOCK

Raw meat and bone, about 2 lb.

Cooked meat, or meat and bone, about 1 lb.

Cold water (fresh, or from cooked meat or vegetables), 3 qt.

To each pound of meat and bone allow of onion, carrot, cut into half-inch cubes, 1 heaping tablespoonful each.¹

Celery, 1 stalk or 1 root.

A bit of bay-leaf.

A sprig of parsley.

Salt, about $\frac{1}{2}$ t.

Peppercorns, 2, or

Pepper, f. g.

Have the bones sawed into inch lengths and split; cut the meat into inch cubes or smaller. Why? If the raw meat only is used, brown one-third of it in a little of the fat in a frying-pan.² Let meat and bones soak in the water for one hour, then simmer in a covered kettle four or five hours, or until the meat is in fragments. About one hour before taking the stock from the fire, add to it the vegetables and seasonings. When the vegetables are very soft strain the stock through a coarse strainer and set it aside for twenty-four hours, or until the fat solidifies on its surface. Remove every speck of this fat, saving it to try out, and if the stock is to be used for clear soup, clear it according to the directions on p. 167.

Bone, commonly regarded as refuse, is called for in the

¹ Seasonings and flavorings may be varied or, in part, omitted.

² By this means the soup gains in flavor, though at the cost of some food value.

directions for making soup-stock. If we compare this stock with bouillon, or with any broth made from meat with little or no bone, we shall find that the first is jellied when cold, the second liquid. What is there in bones to make this difference?

A STUDY OF BONE

A. Examine the ends of a shin-bone sawed in two. Where is the bone the hardest? Where is it spongy? Where soft? The soft substance is marrow. Try to bend or break the bone. Observe the tough fibrous covering on the ends of it.

B. Put one piece of the bone in diluted hydrochloric acid (six parts of water to one part of acid); after a few days compare it with the other piece. Has the acid changed the shape of the bone? its size? How has it affected it? See if you can tie it in a knot. What makes bone hard? What, then, has the acid taken out of the bone?

C. Tie a wire around the other piece of bone, and lay it for half an hour in a hot coal-fire. Remove it by means of the wire. How has it changed? Does it break easily? What part of the bone has been burned?

Structure and composition of bone. — Bone is the hardest of animal tissues, yet it is one-half water; the other half consists of about two-thirds mineral, and one-third animal matter, the mineral being largely *calcium phosphate*, commonly called phosphate of lime; the animal matter chiefly fat and collagen.¹ In the centre of hollow bone is a mass of fatty stuff, the *marrow*. Surrounding, and, in some cases, forming the end of the bone is the flexible, slippery substance called *cartilage*, or *gristle*; and, connecting bones at the joints, are bands or ligaments of cartilage. Cartilage may be considered soft bone, since it differs from bone mainly

¹ Often called *ossein* in bones.

in having less mineral matter. The bones of children and young animals are soft because they are cartilaginous; the older the individual grows, the harder the bones become. The two kinds of material in bone may be separated by soaking in acid, which dissolves the inorganic substance; or by burning, which destroys the organic.

How cooking affects bones. — By long cooking in water the insoluble collagen and similar substances of connective tissue, tendon, cartilage, and bone are changed to *gelatin*, soluble in hot water.¹

But will hot water best draw out the meat juice? How may we contrive to extract all possible food value from both meat and bone? And how may we also give to soup that rich flavor produced only by heating meat to above 212° F.? All these points must be considered if we mean to make the best possible soup out of our materials.

The soup-kettle or stock-pot. — Have for stock-making a deep kettle with a tight-fitting cover; the tighter the cover the smaller is the amount of water lost by evaporation. In an ordinary kettle, stock may, during cooking, lessen by one-half; in a soup-digester with a steam-tight, valved cover, evaporation is so slight that one pint of water instead of one quart may be allowed to one pound of meat and bone.

Fresh material may be added to that already in the stock-pot, provided that once a week the contents are removed and the pot cleaned. Fresh material must be combined with "left-overs" for a satisfactory stock,

¹ In changing to gelatin, collagen takes up water, something as starch does in changing to starch-paste.

cooked meat alone yielding too little soluble material. Fresh herbs and, unless a varied stock of cooked vegetables is on hand, a few fresh vegetables are required for flavoring.

Materials for soup-stock. — Put raw-meat trimmings cut off by the butcher, flank ends of steak, etc., into one jar, bits of cooked meat and bone, except mutton fat, which is rank in flavor, into another jar. Keep the water in which meat has been cooked. Keep *separately*, because it sours in about two days — quicker than meat-liquor spoils — the cooking water from rice and vegetables. Use sparingly water from strong-flavored vegetables, such as onion and turnip, and do not use cabbage or potato water at all.

Celery and asparagus water may be used either for soup-stocks or for cream-of-vegetable soups. (Chap. VIII, sect. 3.) Keep by themselves, and separate from one another, if possible, remnants of vegetables, rice, macaroni, etc.

How to choose soup meat. — What sort of meat shall we choose for soup-making, — tender or tough, with bone or without? What advantage has the meat from young creatures over that from old? Soup meat should include some fat, because the cake formed by it when cold, if kept unbroken, helps to preserve the stock.

Compare a cut from the loin of beef with one from the leg (shin). Compare a shin of beef with a knuckle of veal (the joint of a calf's hind leg). Which will yield the most juice? the most gelatin? the highest flavor? Which of these cuts would you expect to find the cheapest? Why?

HELPFUL HINTS ABOUT MAKING AND USING SOUP-STOCK

1. Have all trimmings sent home by the butcher to be used in making stock.
2. On account of its strong, fatty flavor, avoid using much mutton in stock containing other meat.
3. For white stock use veal, or veal and chicken; for dark brown stock use beef, part of it browned; and brown all the vegetables. Caramel or Kitchen Bouquet is used to darken and flavor stock.
4. Stock made without vegetables keeps best in hot weather. When taking out a portion of such stock for soup, add for each pint of it one heaping tablespoonful of each vegetable included in the Directions for Making Soup-stock, cook them in it one hour, and strain.
5. A little salt helps to preserve stock, but it must be used sparingly at first, because the stock grows saltier as it lessens by evaporation.
6. Do not try to extract the last bit of gelatin from bones; too long boiling gives stock a flavor of glue.
7. If you must use the stock the day it is made, skim off what fat you can, and remove the rest as completely as possible with absorbent paper, or with a bit of ice wrapped in cloth. The fat hardens on the cloth and can be scraped off.
8. Cook vegetables, macaroni, and other materials to be served in soup in a small quantity of stock, and add this with them to the portion to be served. If, however, the stock is weak, so that it would be improved by boiling down, cook this material in the whole quantity to be sent to table.

9. Stock used instead of water in meat sauces, gravies, and stews makes them richer. By boiling meat in stock the stock itself is enriched.

In spite of care in keeping soup-stock below the boiling-point, some albumin coagulates, a part of which settles and a part rises as scum. Skimming off this scum lessens the food value of the soup, already small; soup, both skimmed and cleared, is a stimulant merely, still, for the sake of appearances, a perfectly clear soup is sometimes desired.

To clear soup-stock. — Put into a saucepan the stock to be cleared, and into it stir the whites and crushed shells of as many eggs as there are quarts of stock. Heat and stir until it has boiled for two minutes; then keep it hot, without letting it simmer, for twenty minutes, in order that the albumin, as it coagulates, may entangle every solid particle in the stock. Pour through a fine strainer held above double cheese-cloth laid over another strainer. The first strainer keeps the scum from clogging the cloth.

MEAT SOUPS

The following soups may be made from either cleared or uncleared stock. Season them to taste before serving. For macaroni and vermicelli soups, beef stock is preferable; for rice and barley soups, mutton or chicken stock.

Tomato soup. — Add to one pint of stock one-half can of tomatoes, stewed and strained, and one-half teaspoonful of sugar.

Mixed vegetable soup. — (*In winter.*) To one quart of stock add two heaping tablespoonfuls each of chopped onion fried, chopped celery, and turnip either chopped or cut with a vegetable cutter, one tablespoonful of carrot prepared like the turnip, and one cupful of cooked and strained tomato. (*In summer.*) Omit the tomato and onion, and add small green peas, flowerets of cauliflower, or asparagus tips, or all three.

Noodle soup. — To one quart of stock add one-fourth cupful of noodles.

Macaroni, vermicelli, rice, and barley soups take their names from the material served in them. Serve with these soups crusty bread (plain rolls, or inch-thick slices from a French loaf), toasted crackers buttered, or croûtons. The dextrin in these, like the extractives of meat, stimulates digestion. (Directions for Preparing Croûtons on p. 253.)

Food value of soup and soup meat. — A strong broth contains only about 5% of nutritious material. Soup as ordinarily made is weaker than this. Yet soup has a strong meat flavor, and the meat left in the soup kettle is almost tasteless. This is because the extractives, which give meat its flavor, pass wholly into the stock. The extractives, although not nutritious, stimulate the secretion of gastric juice. The combined stimulating and warming effect of soup prepares the stomach for solid food.

Soup meat, if well seasoned, may be used in croquettes and réchauffés (pp. 175, 222). It is likely to be better digested if flavored with meat extract, or if served after a meat soup.

What class of foodstuffs does gastric juice act upon? Which of these are found in meat? What other foodstuffs does meat contain?

GELATIN JELLIES

Gelatin is used for making many sweet jellies and desserts, also such jellies as mint jelly and tomato jelly. One ounce of gelatin will stiffen from three and one-half to four cupfuls of water in ordinary weather. In hot weather or on a wet day more is required; in cold weather, less. If fruit is to be moulded in the jelly, use one and one-half ounces of gelatin.

General directions for using gelatin. — First soften the gelatin by soaking in cold water,¹ then dissolve it in boiling water, but never boil it. If stirred much while hot the gelatin may become stringy and refuse to jelly; for this reason, do not stir to help sugar dissolve, but keep the gelatin mixture hot by setting the bowl over hot water. Strain it through cheese-cloth or muslin doubled into a mould, and set it away to cool, in summer on ice. It will jelly in from three to six hours. The larger the proportion of gelatin to the liquid, the sooner it sets, but too much makes the jelly taste of gelatin, and also makes it tough. Use a mould of earthen or enamelled ware wet with cold water just before it is filled. - See that it stands level while the jelly is cooling.

¹ Cooper's gelatin softens in ten minutes; Knox's requires at least fifteen; some kinds take longer. Follow the directions on box. Granulated gelatin is more easily measured than that in sheets or shredded. A two-ounce box of granulated gelatin holds five tablespoonfuls. Manufacturers often use the spelling *gelatine*.

LEMON JELLY

Gelatin, 1 oz., or if granulated, 2½ tb.	Boiling water, 2½ c.
Cold water, ½ c.	Sugar, 1 c.
	Lemon juice, ½ c.

Soak the gelatin in the cold water, add the boiling water, then the sugar, and stir till the latter is dissolved. Add the lemon juice, and strain through a cloth wrung out of hot water and laid over a wire strainer into a mould wet with cold water.

To vary the flavor, boil in the water one inch of stick cinnamon, and the thinly shaved peel (yellow only) of one or two lemons.

For Coffee Jelly use one cupful of strong boiled coffee,¹ and two of boiling water. Strain through a fine cloth, doubled.

Serve these jellies turned out in a glass dish, with cream, whipped or unwhipped; or make them a little less stiff, and serve lightly broken up, as "Sparkling Jelly."

How gelatin is made. — Gelatin is made from bone and hide, chiefly from scraps left from making bone buttons and skins from calves' faces. The gelatin is extracted from these by cooking them with water below the boiling-point. The solution of gelatin is filtered, concentrated, and cooled in large blocks. The blocks are sliced, and the slices dried on wire racks, and either powdered or shredded.²

¹ Made with two tablespoonfuls of coffee to one cupful of water.

² Analysis shows that some gelatin, especially the cheaper kinds, such as many bakers, confectioners, and ice-cream makers use, is impure and unsafe to eat. The best American brands are among the best made.

Gelatin as food. — Although gelatin may serve as fuel and, in conjunction with other proteins, *help* to build tissue, it is not an important food. It is used because it provides a convenient way of serving other foods. (P. 141.)

HOW TO COOK TOUGH MEAT: STEWING AND BRAISING

We have seen that tender meat is cooked chiefly to improve its color and flavor, not to make it more digestible; but tough meat requires first of all that its connective tissue be softened to enable the digestive juices to reach the albuminous matter within. (What substance in plant foods must be softened by cooking in order that the starch may be reached?) By stewing, tough meat may be softened with the least possible sacrifice of juiciness and flavor.

LAMB STEW

Neck or shoulder of lamb, 1½ lb.	Rice, 2 tb.
Boiling water, about 1 pt.	Tomato, strained, 1 c.
Potatoes, 4, medium-sized, quartered and parboiled. ¹	<i>or</i>
Onion, 1, about 1½ inches in diameter, sliced.	Tomato ketchup, 1 tb.
	Salt and pepper.

Brown the onion in a little of the fat in a saucepan; put with it the meat cut roughly into cube-shaped pieces about one and one-half inches thick, and sprinkled with salt and pepper. Cover them with boiling water, heat this to the boiling-point again, then let it simmer directly over the heat for two hours; or cook it over hot water for three hours, or until the meat is tender. After

¹ Boiled by themselves for five minutes. Why is this done?

one hour of simmering add the rice; half an hour before dishing the stew, add the potatoes; when they are done remove the bones and pieces of fat, stir in the tomato or ketchup, add salt and pepper, if needed, and serve.

How does stewing differ from boiling? from soup-making? Why not leave the meat whole? Why not cut it as small as for soup?

What makes a stew good. — In a good stew the meat and vegetables are tender, the broth thick and savory. Onion, ketchup, minced parsley, tomato, Worcestershire sauce, or other vegetables and condiments may be used to give flavor. Lamb or mutton stew may be thickened with rice; in beef stew flour is commonly used. Stew may be served in a platter within a border of boiled or steamed rice.

For a brown stew, the meat and sometimes the vegetables are browned in hot fat before being simmered. A brown stew without vegetables is a fricasee (French *fricasser*, to fry).

Start a brown stew in cold water. Why?

Dumplings for brown beef stew. — Sift together two cupfuls of flour, two teaspoonfuls of baking-powder, and one teaspoonful of salt. Stir in enough *milk* or *water* to make a stiff drop-batter. When the stew is cooked, set it where it will boil. Drop in the dumpling mixture by tablespoonfuls, cover closely, and boil the broth steadily *without lifting the cover*, for twelve minutes. Boiling the meat for a short time *after* it is tender will not harden it.

How do dumplings differ from biscuit? Why is no shortening used in dumplings?

Choosing stew meat. — Stew meat should be selected from a cheap cut, as higher-priced meat is better cooked in other ways; it should contain bone enough to make the broth gelatinous and well-flavored, also fat, since lean that lies next to fat is less watery than an all-lean piece. What cuts of beef, of lamb or mutton, and of veal, possess these points?¹ (See table on pp. 186 to 193.) Part of the melted fat may be skimmed off before thickening the stew; the flour or rice will absorb the rest.

Braising is steaming meat in its own juices — a method suitable for solid pieces of meat not tender enough for roasting, but of better quality than those utilized in soups and stews. (For cuts of meat suitable for braising, see table.) The retention of steam under a cover, together with basting with the broth, keeps the meat moist enough to permit the juices to flow, while the oven heat is intense enough to develop a rich flavor in both meat and broth.

ROLLED FLANK OF BEEF (PLATE X)

One flank steak, or one pound of top-round steak one-half inch thick.

Suet, 2 or 3 small slices.

Carrot, cubed, $\frac{1}{4}$ c.

Onion, 1 small one, sliced.

Boiling water or stock, 1 c.

Stuffing made from: —

Soft bread crumbs, 1 c.

Celery cut fine, 2 tb.

Melted butter, 2 tb.

Salt, $\frac{1}{2}$ t.

Parsley cut fine, 2 tb.

Paprika, $\frac{1}{8}$ t.

Onion juice, $\frac{1}{2}$ t.

¹ Top round of beef may be larded, browned, and stewed very slowly for four or five hours. Cooked in this way with vegetables it is called *Beef à la Mode*.

Trim the edges of the steak, spread over it the stuffing, roll and tie it, and lay it on the onion and carrot in a pan, with the suet on top. Pour the water or stock into the pan; cook closely covered until tender (about 1 hour or more), in a hot oven; then uncover, and cook until browned. Serve with Brown Gravy made from the drippings in the pan.

The steak may be larded instead of covered with suet. Insert with a larding-needle two rows of salt-pork strips (*lardoons*) two inches long and one-fourth of an inch thick.

HELPFUL HINTS ABOUT BRAISING AND STEWING

1. Remnants of cooked meat may be stewed, either by themselves, or with uncooked meat.
2. Only the best portions of stew meat should be browned; very coarse or gristly pieces may be simmered by themselves, and only the broth added to the stew.
3. To make sure that the stew shall not boil, cook it in a double boiler, allowing half again as much time as for cooking by direct heat. Stew meat that has boiled may look tender because its fibres, loosened by the softening of the connective tissue, fall apart; but the fibres themselves will be found hard to chew and digest.
4. In stewing, add water from time to time, enough to keep the meat covered. If the broth is too watery, boil it down before pouring it over the meat.
5. Braised meat may be cooked uncovered the latter part of the time.

PLATE IX.



TOP SIRLOIN READY FOR ROASTING.



LEG OF MUTTON.
(Hind.)



FOREQUARTER OF MUT-
TON. (Rib portion sep-
arated from shoulder.)



ROLLED FLANK OF BEEF, LARDED, BRAISED, AND ARRANGED
ON A BED OF VEGETABLES.



WARMED-OVER DISHES (RÉCHAUFFÉS¹)

Delicious meat dishes may be prepared from remnants of cooked meat such as thriftless housekeepers throw away and unskilful ones warm over carelessly in a frying-pan.

Learn to combine acceptably whatever materials you have on hand, varying the regular recipes to suit the case. For example, you may substitute bread-crumbs or macaroni for potatoes, stewed tomatoes for gravy, rice for macaroni, and so on. Be sure to make the dish look attractive, and if possible find for it an appetizing name. Skill in using up left-overs provides many a dainty and saves many a dollar.

How to prepare meat to be used in réchauffés. — Remove all bone and gristle, and, when the meat is to be hashed, trim off the fat. Save the bones for soup-stock, the fat for trying out. Cut the meat in cubes or thin slices, or chop it fine. If tender and well-cooked, take care to *reheat* it only, not *recook* it; if tough or underdone, simmer it until tender, saving the cooking water to make a sauce. Season it rather highly, since meat after cooling is less savory than when fresh-cooked.

Directions for making hash. — Mix and heat together equal parts of chopped cooked meat and chopped boiled potatoes. If dry, add for each pint of hash one tablespoonful of butter or drippings, and two of hot water or stock. Season with salt and pepper, adding onion juice, parsley, or other seasoning, if desired.

¹ French, *réchauffer*, to heat again.

To brown hash, add two teaspoonfuls of milk; let the hash cook unstirred till brown on one side; fold like omelet.

CORNED BEEF HASH

Boiled corned beef (about one-fourth fat), 1 part.

Boiled potatoes, 2 parts.

Onion juice, a few drops.

Pepper.

Chop or grind the corned beef, not too fine. Chop the potatoes by themselves and mix them with the meat. Season and heat over hot water, or in a frying-pan over moderate heat.

Minced meat on toast. — Chop fine any cold, lean meat. Season, and warm in gravy or sauce sufficient to moisten it. Spread on slices of crisp toast dipped in salted water. (P. 89.)

CHARTREUSE OF RICE AND MEAT

Rice, 1 c.

Cooked meat, minced, 2 c.

Bread or cracker crumbs, $\frac{1}{4}$ c.

Hot water, stock, or gravy enough to

enable the meat to be packed

solidly.

Salt. Pepper.

Other seasonings to taste; *e.g.*, with chicken, two teaspoonfuls of parsley, fine cut, and celery salt; with veal, two tablespoonfuls minced onion fried in butter, and ten or twelve drops of lemon juice; with mutton or lamb, fried onion and minced celery, or celery salt; with beef, fried onion.

Boil the rice. (For directions, see p. 74.) Prepare and mix the other ingredients. Line a buttered mould with a one-half inch layer of boiled rice, well pressed down; pack in the meat mixture; cover it with rice; set the

bowl in hot water ; and steam for about forty-five minutes. Turn out of the mould and serve with Tomato Sauce (p. 158) around it.

Meat pie. — Fill a deep earthen dish with cooked meat cut small. Mix in cut-up potatoes and other vegetables if desired. Moisten with gravy. The gravy should almost cover the meat. If there is not enough, add hot water, and if necessary, thicken it slightly with flour. Season the mixture. For the crust make biscuit dough according to recipe on page 100 (using half the recipe for a small pie). Pat out the dough to the size of the dish, and spread it over the meat. Press down the edges to make it fit the dish. Make a few holes in the crust to let out steam. Bake till the crust is light brown. Mashed potato may take the place of a biscuit crust.

SECTION 2. MEAT: CUTS, MARKETING, AND FOOD VALUE

Section 1 has made us familiar with a number of cuts of beef and mutton, and with ways of cooking them. In the market we find all these cuts and many more ; in order to select wisely from them the housekeeper must study them until she not only knows one kind of meat from another, and poor meat from good, but can readily recognize any cut, trimmed or untrimmed, and knows the market value and food value of each.

How beef is cut up for sale.¹ — Let us see first in what

¹ Diagrams and descriptions in this text-book follow New York City customs. For other ways of cutting and of naming cuts see Farmers' Bulletin No. 84, Meats: Composition and Cooking.

shape the butcher receives his stock-in-trade. The beef-creature is sent to market split into halves called "sides of beef." These the butcher divides, first into forequarter and hindquarter, then into pieces (see Fig. 11), and these into cuts to suit customers. The weight of a side of beef as it hangs by the hind leg throws the shoulder-bone forward and the thigh-bone backward, reversing the angles

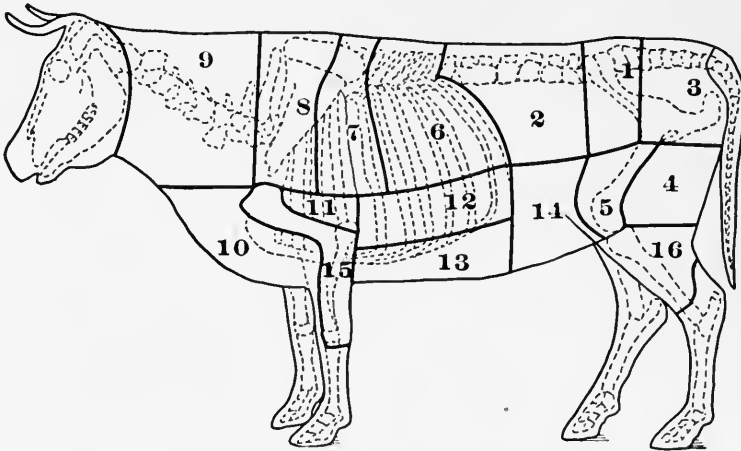
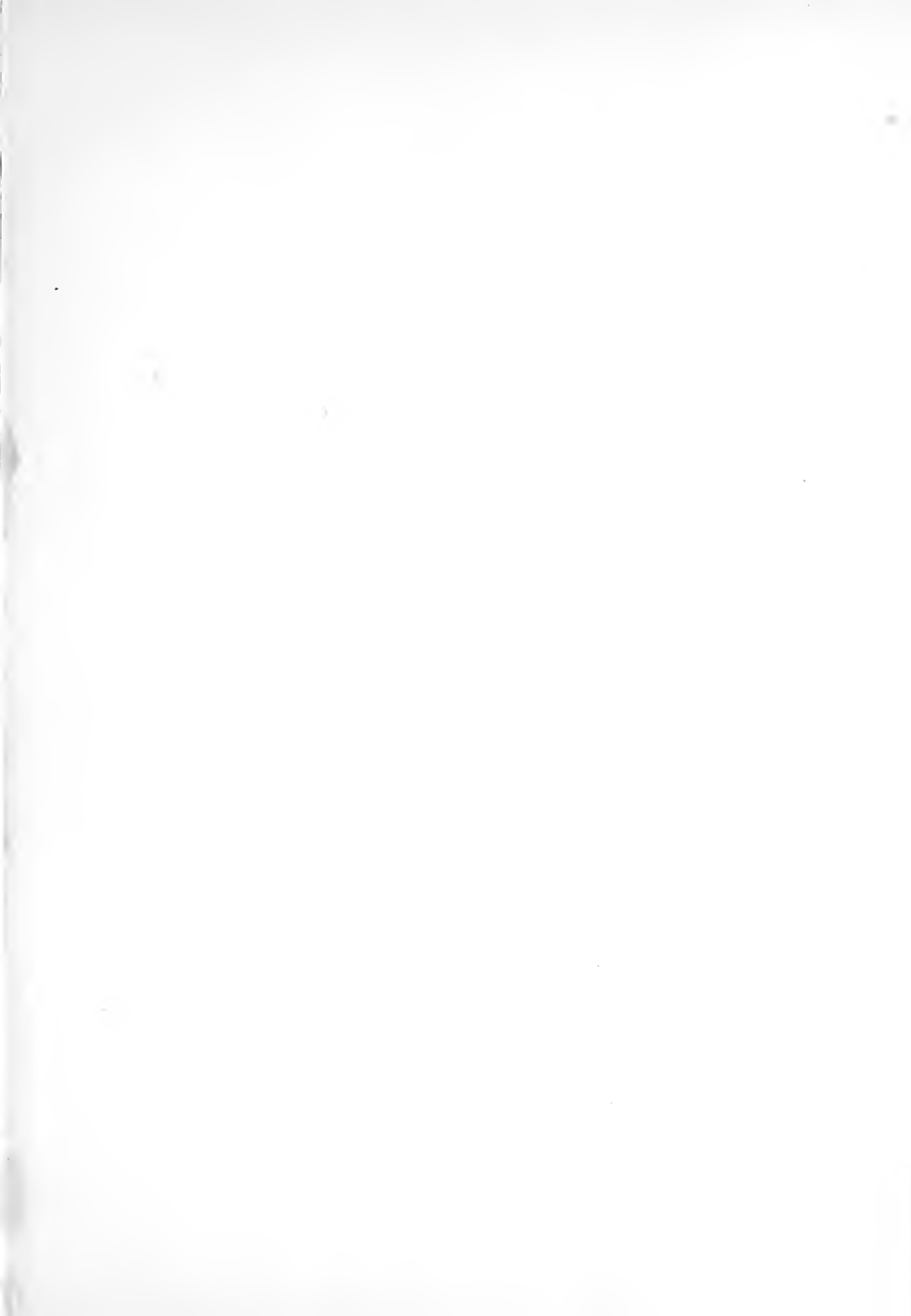

FIG. 11. — Diagram showing cuts of beef.

- | | | | |
|-------------------------------|-----------------|-----------------|------------------|
| 1 and 2 = loin (1 = sirloin). | 6 = prime ribs. | 10 = brisket. | 14 = flank. |
| 3 = rump. | 7 = blade. | 11 = cross-rib. | 15 = shoulder. |
| 4 = round. | 8 = chuck. | 12 = plate. | 16 = leg (shin). |
| 5 = top sirloin. | 9 = neck. | 13 = navel. | |

which, in the living animal, they make with the back-bone, and altering the position of the muscles attached to them.

Description of the cuts of beef. — Upon severing the forequarter from hindquarter just back of the ribs, we recognize on the latter the small end of the loin. The first few steaks cut here are short in the flank and have little tenderloin; they are called *short, club, or Delmonico steaks*. *Porter-house* cuts lie between these and the junc-



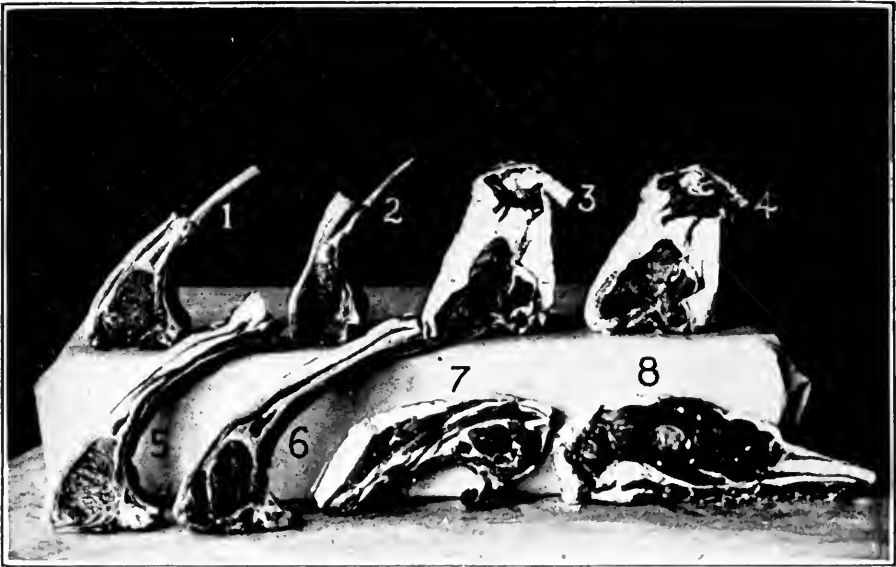

LAMB AND MUTTON.

1 and 2. Rib chops, Frenched.

3 and 4. Loin chops.

5 and 6. Rib chops.

7. Blade shoulder chop.

8. Round-bone shoulder chop.

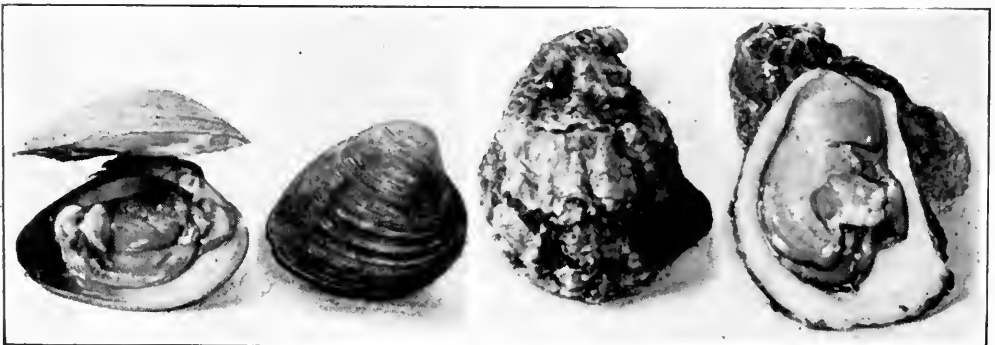

CLAMS.

OYSTERS.

Shell open.

Shell closed.

Closed.

Top shell removed.

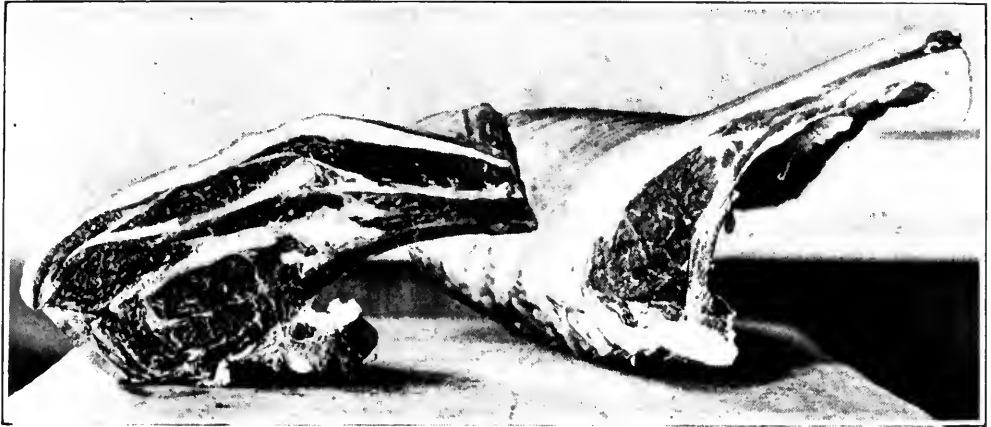

a

b

a, chuck ; *b*, prime ribs.



a

b

a, round of beef with slices of top round taken off. *b*, flat-bone sirloin steak, trimmed ; trimmings shown.



tion of the hip-bone with the spine, and the *sirloin* between this joint and the thigh-bone. In the hollow of the loin lie the *kidneys*, surrounded by hard fat, the *suet*. A solid chunk of flesh below the sirloin is known, queerly enough, as *top sirloin*; the *round*, of which top sirloin is really part, consists of the mass of flesh back of the hip-bone. A streak of gristle running down through this portion divides it into top and bottom round, properly *inside* and *outside* round, but called otherwise because the round is always laid on the block inner side up. (Plate IX.) The leg severed from the round at the lower end of the thigh-bone furnishes upper and lower *shin*. The *rump*, a wedge-shaped piece of coarse meat containing the lower vertebræ and the end of the hip-bone, comes out between the sirloin and round.

The most notable feature of the forequarter is the chest with its arch of ribs, the first six of which, counting forward from the loin, are, both from quality and from position, termed *prime ribs*. Over the seven *chuck ribs* lies the shoulder-blade, which appears at the seventh rib as a streak of yellow gristle, and grows bonier and thicker from there forward. Across the ribs lies the *cross-rib*, a boneless piece of flesh, corresponding to the top sirloin in the hindquarter. The diaphragm inside the ribs forms the thin, coarse strip called *skirt steak*. The *brisket*, adjacent to *chuck*, *neck*, and *fore leg*, includes the breast-bone and part of the four forward ribs.

The muscular wall covering and supporting the creature's belly is sold in sections (Fig. 11) as *plate*, *navel*,

and *flank*. The floating ribs end in the navel. The flank includes the *flank steak*, a thin strip of lean embedded in fat.

Cuts of mutton and lamb.—Mutton and lamb are usually quartered like beef. The *loin* is cut into *chops*. *Hip chops*, corresponding to sirloin steaks, are sold as

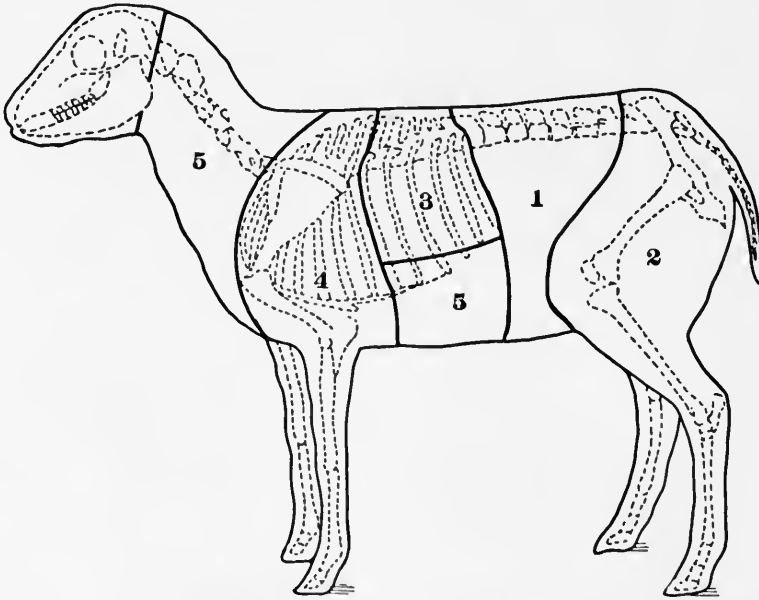

FIG. 12. — Diagram showing cuts of lamb and mutton.

1 = loin.
2 = leg.

3 = rib-portion.
4 = shoulder.

5, 5 = breast.

loin chops, but are inferior, containing bone. The *neck* and *shoulder* sell cheap; the latter is cut for roasting with the fore leg, and if desired, with two or more ribs left on. *Leg-of-mutton* is the hind leg together with what corresponds to the round in beef. A sheep between two and three years old furnishes the best mutton. The age of mutton may be told by breaking the joint of the fore leg; the bones

in a lamb are ridged ; the less distinct these ridges, the older is the animal. By what signs would you know good beef? Good mutton? Hard mutton-fat purified makes *tallow*.

Cuts of veal. — Of the forequarter cuts of veal, the *breast* and *shoulder* furnish stew meat or second-quality

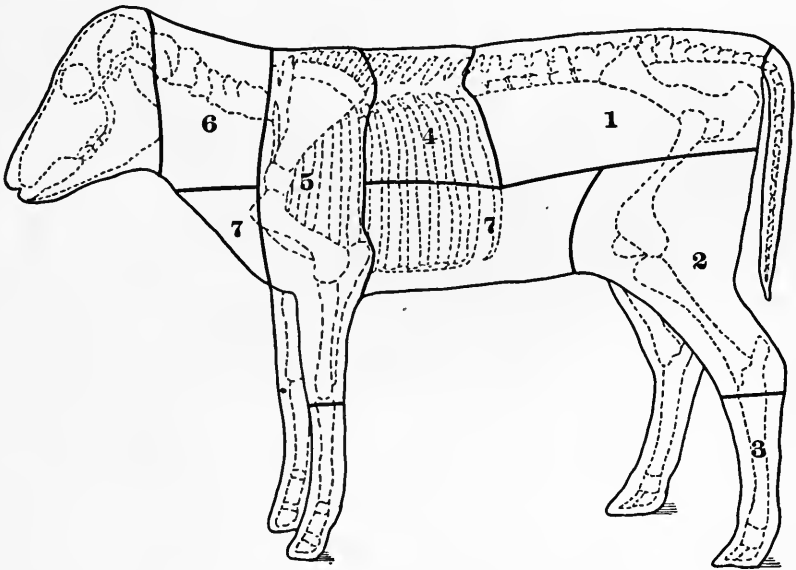

FIG. 13. — Diagram showing cuts of veal.

- | | |
|--------------------------|----------------|
| 1 = loin. | 5 = shoulder. |
| 2 = leg (cutlets, etc.). | 6 = neck. |
| 3 = knuckle. | 7, 7 = breast. |
| 4 = rack. | |

roasting pieces, and the ribs are sold together as *rack of veal*, or separately as *chops*; as in beef, the hindquarter cuts are choicer. Roasting pieces or steaks and chops are cut from both loin and leg, slices from the leg being called *cutlets*. These contain a section of the round leg-bone. Breast and leg, tough in the full-grown animal, are tender in the calf.

How good veal looks. — The best veal, that of a calf about two months old, is pale pink or flesh-colored, with clear white fat. White lean veal is unfit to eat.

Cuts of pork; the appearance of good pork. — The ribs and loin of pork are sold for roasting, or as *chops*. *Hams* are the hind legs, salted and smoked; *bacon*, the flank similarly prepared. The thick layers of fat on the back and

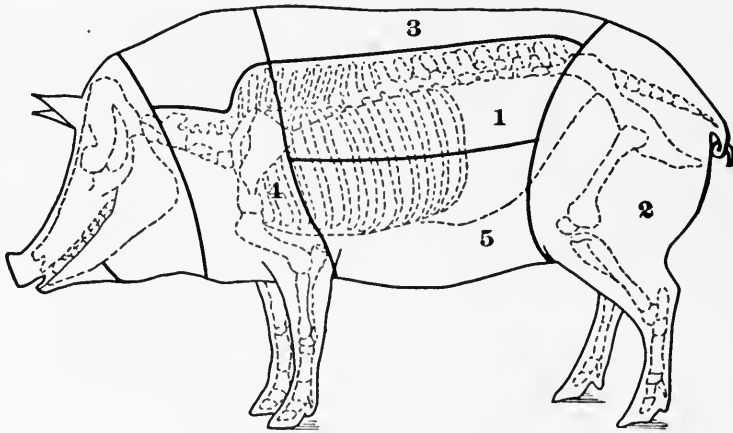

FIG. 14. — Diagram showing cuts of pork.

1 = loin.
2 = ham.

3 = back.
4 = shoulder.

5 = belly.

flank are commonly salted. The strips or "leaves" of kidney fat are "tried out," or rendered, and purified, to make *leaf-lard*; fat from other parts of the hog yields lard of poorer quality. Fat salt pork of good quality is white, or faintly tinged with pink, and has a thin rind. Fresh pork should be pale red and firm, with white fat. Good *sausages* are made of chopped and seasoned beef or pork, or both combined, packed in intestines. As it is easy to use all sorts of slaughter house scraps in them, as well as starch

and other adulterants, it is important to buy only those made by a reliable manufacturer.

Internal organs used for food. — The *tongue, liver, kidneys, heart*, and some other organs of the ox and sheep are used for food. *Tripe*, the lining of a beef's stomach, is sold boiled. The *brains, pancreas, and thymus gland of calves* are considered dainties; the latter two are termed *sweet-breads*.

Meat inspection. — Meat should come from healthy animals, should be handled in cleanly fashion, should not be allowed to spoil, and should not be kept from spoiling by harmful preservatives. The United States government inspects all meat to be sent out of the state in which it is killed. Meat killed and marketed in the same state is not always inspected. Look for the inspector's stamp on meat you buy. Inspected meat may cost more, but it is safer. Even inspection does not make pork safe to eat, unless it is cooked until it is white all through.

Economy in marketing; the cheapest meat not always the most economical. — Since less than one-fourth of the weight of a dressed beef consists of very tender meat, these tender portions are necessarily expensive. The less tender cuts, being more nutritious, are more economical; and, if properly cooked, are good eating, better, indeed, than higher-priced cuts badly cooked. The value of any cut depends not alone upon the quality of the edible portion, but also upon the proportion this bears to the refuse (bone, gristle, etc.). For example, prime ribs are even more expensive than they seem, because the purchaser pays for

so much bone. Again, a cheap piece, containing much refuse, may be less economical than a higher-priced one, all of which is eatable.

Recently killed meat is tender. It soon stiffens, owing to the clotting of certain proteins (p. 152). It becomes tender again after a time. Meat (and poultry) which is to be stored or to be shipped any distance must be kept very cold. Sometimes it is frozen. Cold storage is a convenience, but it tends to injure the flavor of both meat and poultry, and they spoil quickly when taken out.

The food value of meat. — The lean of meat consists chiefly of protein and water. The more fat there is with a piece of meat, the greater its fuel value. If the fat is not eaten, this is lost. The extractives in meat cause its odor, and together with mineral salts, its taste. People like meat because of its flavor and stimulating properties.

Americans, however, tend to buy more meat than they need, and to spend more for it than they can afford. Formerly meat was cheap, because there was plenty of land on which to keep cattle. As more and more of this land is used for grain and other crops, the price of meat rises. There are other foods, which may be substituted, that are even better for us than meat. Meat three times a day is probably unnecessary for any one, and hurtful except to people actively working or exercising. (See p. 143.)

Digestion of meat. — All kinds of meat are almost completely digestible, although not all equally easy of digestion. The lean of meat undergoes the first stage of its digestion in the stomach. The process is promoted by the extrac-

tives, which excite the secretion of gastric juice. The digestion of fat takes place mostly in the small intestine. Pork and veal are harder to digest than beef and mutton. Tender short-fibred meat passes through the gastric stage of digestion and leaves the stomach more rapidly than that which is coarse-grained and tough. Proper cooking may make tough meat almost equal to tender in ease of digestion, while careless cooking may dry and harden the choicest cuts.

Experiment to illustrate the gastric digestion of meat. — Put a few bits of raw lean meat into a test-tube, and cover them with water; add a little pepsin and a few drops of hydrochloric acid. (Pp. 86, 88 and footnote.) At end of one hour and a half, and at intervals afterward, examine the meat, noting its gradual solution.

BRIEF REFERENCE LIST

For further development of topics treated in this section see:—

- SHERMAN: *Food products*. Ch. 6.
SNELL: *Household chemistry*. (Especially for experiments and tests.)
WARD: *Grocer's encyclopedia*. (Especially for colored illustrations of cuts. Also article on Gelatin.)
WILEY: *Food and its adulteration*. (Especially for illustrations of cuts.)
UNIVERSITY OF ILLINOIS: *Experiment station bulletin* 158. Beef.
U. S. DEPT. OF AGRICULTURE: *Farmers' bulletin* 586. Mutton.
BUCHANAN: *Household bacteriology*. P. 296, Ripening of meat.
BARROWS: *Principles of cookery*. Pp. 133-139 and 170-180, Use of left-overs.
STILES: *Nutritional physiology*. P. 151, Why gelatin is inferior as a tissue-builder.
JORDAN: *Principles of human nutrition*. P. 30, Commercial meat extracts.

A TABLE OF INFORMATION ABOUT CUTS OF MEAT

BEEF

NAME AND LOCATION OF CUT	HOW SOLD	CHARACTER AND QUALITY OF MEAT	PREPARED FOR EATING
<p>LOIN. All between first rib and rear end of hip-bone.</p>	<p>In slices: <i>a</i>, one to two inches thick: Delmonico, porter-house, and sirloin steaks; <i>b</i>, thicker slices for roasting.</p>	<p>Lean, mostly tender; fat on edges; little bone. Sirloin steaks: 1, Hip-bone sirloin, next to the porter-house, with large tenderloin, is the best; 2, flat-bone sirloin second choice. Larger tenderloin, round-bone sirloin, poorest.</p>	<p>Best quality for roasting and broiling.</p>
<p>RUMP. Back of loin.</p>	<p>Sold either whole or in halves. In latter case, aitch-bone is split in two.</p>	<p>Tough, with considerable bone.</p>	<p>Corned and boiled.</p>

<p>ROUND. 1. Top: inside of thigh. 2. Bottom: outside of thigh.</p>	<p>Sliced or cut thick. Best part of bottom round sometimes cut with top for dealer's advantage. Cut thick.</p>	<p>Solid piece of juicy, fairly tender, lean, bordered with fat. Good meat has thick piece of fat between top and bottom round. Similar to top round, but tougher, has streaks of gristle.</p>	<p>Excellent for braising, pot-roast, and beef à la mode, also for beef juice and beef tea; fairly good roasted or broiled. Pot-roast, soup, mince-meat.</p>
<p>TOP SIRLOIN. Between sirloin and round.</p>	<p>In steaks, or for roasts.</p>	<p>Solid piece similar to top round.</p>	<p>Fairly good steak; excellent pot-roasted.</p>
<p>PRIME RIBS. First six ribs.</p>	<p>Sold in pieces containing upper parts of two or more ribs; may be boned and rolled; with ribs left in is called "standing roast."</p>	<p>Similar in quality to loin, but has more bone and no tenderloin.</p>	<p>Fine roasts.</p>
<p>BLADE. 7th, 8th, and 9th ribs.</p>	<p>Cut like prime ribs; blade removed.</p>	<p>Similar to prime ribs, but has more gristle and bone.</p>	<p>Fairly good roasting-piece.</p>

A TABLE OF INFORMATION ABOUT CUTS OF MEAT. — *Continued*

NAME AND LOCATION OF CUT	HOW SOLD	CHARACTER AND QUALITY OF MEAT	PREPARED FOR EATING
CHUCK. 10th, 11th, 12th, and 13th ribs.	In steaks, or boned and rolled.	Spinal processes long; tough.	Braising, pot-roasting, or stew; steaks broiled.
NECK.	To suit purchaser.	Juicy and well flavored, but tough.	Excellent for stews and soup.
BRISKET. Between the fore legs.	To suit purchaser.	Layer of juicy, well-flavored meat over fat and bone.	Corned and boiled.
CROSS-RIB. Lies across the ribs.	To suit purchaser.	Muscles all run one way; no waste.	Pot-roast or inferior steak.
PLATE. On the side, be- low ribs.	To suit purchaser.	Has layers of fat and lean, with thin bones (ends of ribs) at bottom.	Corned and boiled.

<p>NAVEL. Middle part of belly.</p>	<p>To suit purchaser.</p>	<p>Similar to plate, but has less bone.</p>	<p>Usually corned and boiled.</p>
<p>FLANK, below the loin. 1. Thick flank. 2. Flank steak.</p>	<p>1. To suit purchaser. 2. Whole.</p>	<p>Coarse and tough; no bone, fine flavor.</p>	<p>1. Stewed or boiled. 2. Rolled and braised. (Should not be corned, because it has no fat or bone to protect its juices.)</p>
<p>FORE LEG OR SHIN.</p>	<p>Whole, or to suit purchaser.</p>	<p>Tough, with bone and tendon.</p>	<p>Soup.</p>
<p>HIND LEG OR SHIN.</p>	<p>To suit purchaser.</p>	<p>Fat, lean, and bone; juicy, but tough and full of tendons.</p>	<p>Soup.</p>
<p>SKIRT STEAK (diaphragm) Inside of plate and navel.</p>	<p>Sold whole.</p>	<p>Lean; juicy, but lacking in flavor.</p>	<p>Stew.</p>

A TABLE OF INFORMATION ABOUT CUTS OF MEAT. — *Continued*

VEAL

NAME AND LOCATION OF CUT	HOW SOLD	CHARACTER AND QUALITY OF MEAT	PREPARED FOR EATING
LOIN. Includes what in beef is loin and rump.	Sliced into chops, or sold in roasting-pieces.	Next in value to the leg.	Roasted; chops fried.
LEG (hind).	Sliced into cutlets one-half inch thick, or into thicker slices for <i>fricandeau</i> .	Most valuable part of the calf; no waste.	Cutlets fried; <i>fricandeau</i> roasted.
KNUCKLE. Lower part of hind leg.	Sold whole.	Gelatinous.	Soup and stew.
RACK. Ribs.	Chops.	Tender.	Fried.
SHOULDER. Includes fore leg and part of ribs.	Sold whole.	Tender and well flavored.	Stuffed, and roasted or braised.

<p>NECK. May include last four ribs.</p>	<p>To suit purchaser.</p>	<p>Gristly.</p>	<p>Usually stewed.</p>
<p>BREAST. Includes what is brisket, plate, and navel in beef.</p>	<p>Whole, or to suit purchaser.</p>	<p>Bony, mixed with fat.</p>	<p>Roasted.</p>
<p>MUTTON AND LAMB</p>			
<p>LOIN. Same as in beef. (Loin chops correspond to porter-house steak, hip chops to sirloin.)</p>	<p>Into chops three-fourths to one inch thick; also, two whole loins sold in one piece as "saddle of mutton."</p>	<p>Contains tenderloin; has less bone than rib chops, therefore more economical.</p>	<p>Chops broiled; saddle roasted.</p>
<p>LEG. Includes rump.</p>	<p>Whole, as in chops.</p>	<p>Fine, solid meat, fatter in mutton than in lamb.</p>	<p>Roasted or boiled whole; chops broiled.</p>

A TABLE OF INFORMATION ABOUT CUTS OF MEAT. — *Concluded*

NAME AND LOCATION OF CUT	HOW SOLD	CHARACTER AND QUALITY OF MEAT	PREPARED FOR EATING
RIBS.	Single, as chops. If bone is trimmed, they are called "French chops"; also, rib portions of both fore-quarters in one piece as "rack of mutton."	Tender.	Broiled. Rack roasted.
SHOULDER. Includes fore leg, and sometimes two or more ribs.	Whole; usually boned. <i>Note.</i> — Neck and shoulder are sold together as "chuck."	Considerable refuse.	Stuffed and roasted.
BREAST.	To suit purchaser.	Lean and bone, with a little fat.	Stew or broth.
PORK			
LOIN. Ribs and loin.	Chops and roasting pieces.	Tender, and fairly lean.	Broiled or roasted.

<p>SPARE-RIBS. Ribs freed from fat.</p>	<p>Sold whole or in chops.</p>	<p>Nearly all bone.</p>	<p>Usually roasted or sautéd.</p>
<p>HAM. Hind leg, and parts corresponding to rump and round in beef.</p>	<p>Whole, in halves, or sliced (after being smoked).</p>	<p>Solid, lean, with layer of fat half an inch thick or more, on one side.</p>	<p>Usually cured, salted, and smoked, then boiled, or sliced and fried; sometimes roasted fresh.</p>
<p>BACK. Close to backbone.</p>	<p>Cut into strips.</p>	<p>All fat.</p>	<p>Used for frying, flavoring, larding, etc.</p>
<p>SHOULDER. Includes fore leg.</p>	<p>Cured whole, or sold fresh to suit purchaser.</p>	<p>Similar to ham, but not so good.</p>	<p>Cured, salted, and smoked; cooked like ham. Sometimes roasted fresh.</p>
<p>BACON. Belly.</p>	<p>In rectangular pieces, with the skin (<i>rind</i>) left on; sliced thin for purchaser.</p>	<p>Fat, with streaks of lean.</p>	<p>Cured, salted, and smoked; broiled or fried.</p>

SECTION 3. POULTRY

Of the birds we use for food, fowls and chickens, turkeys, and tame ducks and geese are classed together as poultry. Wild fowl, like wild animals used for food, come under the head of game. Among game-birds are quail, partridges, grouse, wild ducks, and wild geese. Game is now scarce and expensive.

Food value and digestibility of poultry and game. — The flesh of ducks and geese, like pork, is so fat that it is not easily digested. Of what use is fat in the bodies of waterfowl?

The light meat from the breasts of poultry is tender, but poorer in flavor than the less delicate meat from the leg and hip-joint, or "second joint," a difference corresponding to that between the loin of beef and the shin and round. The delicacy of the breast-meat is owing partly to the shortness of its muscle-fibres. The legs are tough because fowls use them constantly. Strong tendons run through the "drumsticks." Why is the meat on the wings of domestic fowls so much more tender than that on the legs? Wild fowl have dark, rich meat on breast and wings. Can you explain why?

Selecting poultry. — In market terms, chicken not more than five months old is "spring chicken"; chicken over a year old, fowl.

Would you choose fowl or spring chicken for broiling? for fricasseeing? What effect would stewing have on the flesh of a young bird? on the tendons of an old one?

These tendons should be removed if the fowl is to be roasted, but need not be if it is to be boiled or fricasseed. What is the reason?

In a chicken or young fowl the scales on the legs are yellow and soft, and the breast-bone yielding. How do the bones of young animals differ in composition from those of older ones? Older fowls have horny scales, a hard breast-bone, thicker and yellower skin, and more fat. Pin-feathers, usually an indication of youth, give place to hairs as the bird grows older. A young cock is best for roasting.

A young turkey is known by the same points as a young fowl. Good turkeys have, besides, plump breasts, black legs, and white flesh. A young cock turkey (gobbler) has small spurs. As a rule, hen turkeys are best; old gobblers are never good.

In a young duck or goose the windpipe is brittle enough to snap readily between the thumb and finger, and the feet are soft and yellow. Neither ducks nor geese are good if more than one year old.

How to dress and clean poultry. — Before any kind of poultry is cooked, the hairs and pin-feathers must be removed, the entrails drawn, and the body cleaned. Usually the tendons in the leg are removed.

1. *To remove hairs*, singe the bird over a flame, holding it by neck and legs. A gas or an alcohol flame is best. Lacking these, use lighted paper on top of the range. Cut off the head. Pull out pin-feathers with a vegetable-knife and your thumb.

2. *To remove tendons*, bend the leg back to stretch the

skin over the joint, and cut carefully through the skin. Break the joint. Slip a skewer under one tendon at a time and pull them out. Break off the foot with the loose tendons.

3. *To draw the bird*, make a cut just large enough to admit your hand between one leg and the body. Make another cut around the rump (the part just below the tail). Slip a finger in here and free the entrails from the body. Then put your hand into the other opening and work it carefully around between the entrails and the body, till the entrails can be drawn out all together. Put two fingers down between the neck and the skin and find the windpipe and the crop (a little bag). Draw these out. The kidneys lie in a hollow near the end of the back-bone. Make sure that these are removed. See also that none of the red, spongy lung-substance clings to the chest wall. Turn down the skin on the neck and cut the neck off close to the body. Save the neck. Leave about two inches of skin to fold over. Cut off the oil-bag from the rump. Pieces of fat may be saved to be melted for basting.

4. *To clean*, run water through the body. Wipe it with a damp cloth inside and out.

5. *The giblets*. — The gizzard, heart, and liver, called "giblets," are saved to use in gravy. The gizzard is large, hard, and purplish. The liver, soft and red, lies next to it, with the gall-bladder attached. Gall (bile) is very bitter; in cutting off the gall-bladder take great care not to break it. If a drop of gall escapes, wash instantly whatever part of the bird it touches. Cut slowly through the thick wall

of the gizzard, stopping as soon as the inner sac comes to view. This sac may contain corn or whatever the bird has fed on. Peel off the outer coat without breaking the sac, and throw the sac away. Wash the giblets.

The organs of a fowl may be used to illustrate a lesson on digestion. (See Chap. XV.)

STUFFING FOR CHICKEN

Bread-crumbs, 2 c.	Pepper, $\frac{1}{8}$ t.
Sage or poultry seasoning, 1 t.	Butter, 3 tb.
Salt, 1 t.	Boiling water, $\frac{1}{2}$ c.

Mix crumbs and seasonings. Melt the butter by pouring the boiling water on to it and stir into the crumbs.

DIRECTIONS FOR STUFFING AND ROASTING CHICKEN

With a spoon put stuffing into the neck-opening. Do not cram the cavity full, as the crumbs will swell. Put the rest into the other end of the bird. Draw the neck-skin down and lay over upon the back. Cross wings on back so as to hold this skin in place. With string tie ends of legs to tail.

Place the chicken on its back in a roasting-pan. Rub salt all over it. Roast in a hot oven till brown. Reduce the heat and continue roasting till tender. Baste every ten minutes. Remove string before serving.

Time. — For a three or four pound chicken, one to one and one-half hours.

For basting, use melted chicken fat or melted butter and hot water (three tablespoonfuls of fat or butter to one

cup of water). When this is used up, baste with liquid in pan.

To make giblet gravy. — While the chicken is roasting boil giblets and neck. Have about one pint of water left with them when they are done. Mash liver. Chop heart, gizzard, and meat from neck. When the chicken is taken from the pan, pour the clear fat from pan into a cup or bowl and the settlings into the saucepan with the giblet-water. Brown one-fourth cupful flour in one-fourth cupful of the fat from pan. Add the liquid from the pan about one-third at a time and boil till smooth. Stir in the chopped giblets. Season with salt and pepper and serve in bowl with ladle.

Turkey is cleaned and roasted like chicken. A fowl not tender enough for roasting may be braised. (P. 173.)

Cutting up a fowl for fricassee. — Use a small, sharp-pointed knife. (1) Cut off the head and remove the oil-bag, but do not draw the fowl. (2) Cut the skin between one leg and the body. Bend back the leg. Cut through the flesh, and separate the joint. This leaves second joint and drumstick in one piece. Separate these as you separated the leg from the body. (3) Make a circular cut around the wing close to the joint. Break the wing-joint. Cut off the tip. If desired, divide the wing at the joint as the leg was divided. (4) Cut off and divide leg and wing on other side. (5) Divide the breast from the back by cutting along the ends of the ribs. Break joint at collar-bone. Cut the breast in two. (6) Remove entrails. (7) Divide the back crosswise, breaking the spine. The

lower part of the back may be divided again. (8) Wash the back thoroughly. Wipe the other pieces with a damp cloth.

CHICKEN FRICASSEE

One fowl.

Boiling water or white stock, 1 qt.

One small onion.

Salt, 2 t.

Parsley cut fine, 2 t.

A few sprigs of parsley for garnishing.

Cut up the chicken as directed above.

Brown the onion in a little tried-out chicken fat or drippings, and put it with the chicken meat and bones. Add stock or water, and let it simmer about an hour, or till nearly evaporated. Take out the bone, pour off the liquid, and let the meat and sediment brown delicately, stirring and turning the pieces. Then pour back the liquid, with enough water or stock in addition to make two or three cupfuls in all. Add the salt. After simmering for another hour the chicken should be tender. Arrange the pieces on a hot platter, with the neck and the tail in the centre, the breast-pieces and the wish-bone on top of these, the second joints at one end of the dish, the legs crossed at the other, and the wings and side-pieces on either side. Thicken the gravy with flour wet with cold water, and pour over the chicken; sprinkle and garnish with parsley. The fricassee may be served in a border of rice.

Chicken Stew, sometimes called "*White Fricassee of Chicken*," is prepared like chicken fricassee, except that the chicken is not browned. After removing the chicken,

reduce the liquid to one and one-half cupfuls, add one cupful of milk, and thicken with four tablespoonfuls of flour. Stewed chicken, lacking the flavor of browned meat, is better served on slices of toast than with the comparatively tasteless rice.

BRIEF REFERENCE LIST

For further development of topics treated in this section see : —

SHERMAN : *Food products*. Ch. 7.

U. S. DEPT. OF AGRICULTURE : *Farmers' bulletin*: 182. Poultry as food.

WARD : *Grocer's encyclopedia*. (For various kinds of poultry and game.)

FARMER : *Boston cooking-school cook-book*. (For cooking poultry and game.)

SECTION 4. FISH AND SHELL-FISH

The value of fish as food is likely to be better appreciated as meat becomes scarcer and higher priced. The government preserves the supply of fish for the people by collecting spawn (fish-eggs) and raising young fry to stock waters in which the supply would otherwise become exhausted by constant fishing.

The flesh of fish is in general similar in character to meat, yet it differs from meat in some ways. The points of unlikeness in the flesh of the two classes of animals correspond to differences in the nature of the animals themselves.

Cod, mackerel, haddock, halibut, bluefish, weakfish, shad, herring, and smelts are among the more common fish caught in Atlantic waters. Among the fish common on the Pacific coast are baracuda, sand-dabs, sea-bass, and pompano. The

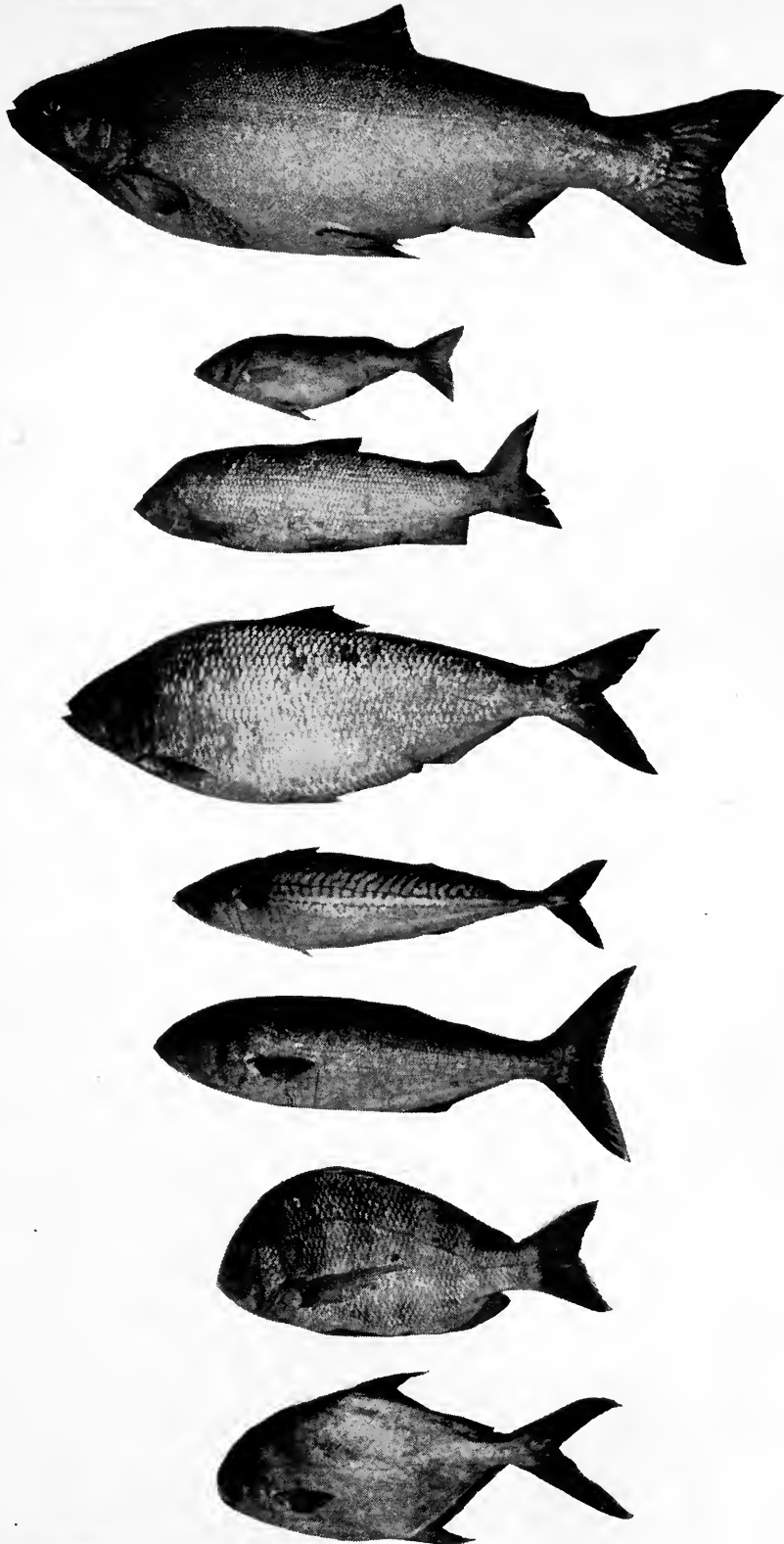

Pompano. Sheepshead. Bluefish. Mackerel. Shad. Whitefish. Yellow perch. Salmon.

FISH.



immense tunny-fish is here known as tuna. Spanish mackerel, flounder, and red-snapper are found in the Gulf of Mexico. Flesh cut from the back of red-snappers is sold by the pound as red-snapper throat. Whitefish, black bass, pike, several kinds of perch, and salmon and brook trout are fresh water fish. Trout are rare and expensive.

Fish proper are distinguished from shell-fish by being *vertebrate*; that is, they have a back-bone.

A STUDY OF THE STRUCTURE OF A FISH

A. How does a fish breathe? Find the gills, — red fringes back of the head. As the water taken into the fish's mouth passes out through the gills, the air dissolved in it gives oxygen to the blood. **B.** What covering has the fish? Are the scales attached at their rear or their front ends? Is there a reason for this? Over the scales lies a thin skin, often containing coloring matter. Mackerel, butterfish, and a few others have no scales. **C.** An air bladder under the spine keeps the fish afloat.

How to know a fresh fish. — In a fresh fish the gills are a bright red, the eyes bulging and bright, the flesh along the back-bone firm and elastic. If the fish can be dented by a finger, do not buy it.

How to clean fish. — Scrape off any scales which have not been removed. Work from tail to head, slanting the knife toward you to prevent scales from flying. Wash the fish inside and out with a cloth wet in cold salt water, and dry with a clean cloth. If the fish is to be broiled or fried, cut off the head and the tail and split it down the back; if to be boiled, cut off the head only; if to be baked, leave whole.

Fish suitable for baking whole are: cod, haddock, bluefish, small salmon, bass, shad, whitefish.

STUFFING FOR BAKED FISH

Stale bread crumbs, 1 c.	Pepper, f.g.
Melted butter, 1 tb.	Onion juice, a few drops.
Salt, $\frac{1}{2}$ t.	Parsley cut fine, 1 tb.

Mix the ingredients in the order given. This recipe makes stuffing for a four-pound fish.

DIRECTIONS FOR BAKING A FISH WHOLE

Time. — Forty-five to sixty minutes.

Fill the cavity with stuffing, allowing it room to swell slightly. Sew the slit over and over with strong thread, taking stitches deep enough not to tear out. If the fish is a dry one (p. 206), cut gashes crosswise, and put in them strips of fat salt pork about one inch long, or insert the strips with a larding-needle.

Skewer and tie the fish into the shape of the letter S, and set it upright, surrounded by bits of fat salt pork, on a greased fish sheet on a baking-pan. Bake until brown, basting often. Serve with Drawn Butter or Hollandaise Sauce.

If you have no fish sheet, lay two strips of cloth across the pan, and lift the fish, when done, by these.

Fish suitable for broiling. *Split.* — Mackerel, young cod, bluefish, whitefish, shad, trout, etc. *Sliced.* — Chicken halibut and salmon. *Whole.* — Smelts, perch, and other small fish.

DIRECTIONS FOR BROILING FISH

Time. — For small fish, five to ten minutes; for large fish, fifteen to twenty minutes.

Use a close-barred double wire broiler. Grease it when hot with salt-pork rind. See that the fish is wiped dry; sprinkle it with salt and pepper; and, if not oily, rub it with melted butter.

Broil split fish with the flesh side to the heat until browned; then broil the other side till the skin is crisp. Broil small fish close to the heat, turning occasionally. Turn slices of fish often.

When cooked, carefully loosen both sides of the fish from the broiler, and slip off on to a hot platter. Spread with butter, salt, and pepper, with Maître d'Hôtel Butter (for recipe, see p. 157), or garnish with parsley and slices of lemon, and serve with Tartar Sauce.

Fish suitable for boiling. — Thick pieces of salmon or halibut, shoulder of cod, whole small cod, haddock, blue-fish, etc.

DIRECTIONS FOR BOILING FISH

Time. — Varies with fish from thirty to forty-five minutes.

To the water in which the fish is to be boiled, add the juice of half a lemon or one-fourth of a cupful of vinegar. Place the fish on a fish-rack or a plate, or coil it in a wire basket. If on a plate, tie fish and plate in a piece of clean cheese-cloth. Any fish not boiled whole keeps whiter if wrapped in cloth. When the water boils, lower the fish

into it, and let it simmer until the flesh separates from the bones. When the fish is nearly done, put in one tablespoonful of salt. Garnish with parsley and slices of lemon, and serve on a platter, with Drawn Butter, Egg Sauce, or Tartar Sauce.

FISH SAUCES

DRAWN BUTTER

Butter, $\frac{1}{3}$ c.	Water, $1\frac{1}{2}$ c.
Flour, 3 tb.	Salt, $\frac{1}{2}$ t.
Pepper, f.g.	

Mix flour, salt, and pepper with one-half the butter, pour on the water, and stir over the fire until the sauce boils. Add the rest of the butter in bits, stirring until it is absorbed.

For Egg Sauce, add to Drawn Butter two hard-cooked eggs chopped.

TARTAR SAUCE

Lemon juice, 1 t.	Worcestershire sauce, 1 tb.
Salt, $\frac{1}{4}$ t.	Vinegar, 1 tb.
Butter, $\frac{1}{3}$ c.	

Heat together in a bowl over hot water the vinegar, lemon juice, salt, and Worcestershire. Brown the butter in a frying-pan, and strain it into the mixture.

Ways of reheating fish. — 1. *Creamed fish.* Remove the skin and bone; pick the fish into flakes with a fork; and heat it in Drawn Butter or White Sauce. 2. *Scalloped fish.* Mix flaked fish with White Sauce and minced parsley, and bake it, covered with buttered crumbs, in a baking-dish, or in clam shells. 3. *Fish hash.* Mix flaked fish with

U.S. Department of Agriculture
Office of Experiment Stations
A.C. True: Director

Prepared by
C.F. LANGWORTHY
Expert in Charge of Nutrition Investigations

COMPOSITION OF FOOD MATERIALS.



Protein



Fat



Carbohydrates



Ash



Water



Fuel Value
1/16 Sq. In. Equals
1000 Calories

COD

Lean Fish

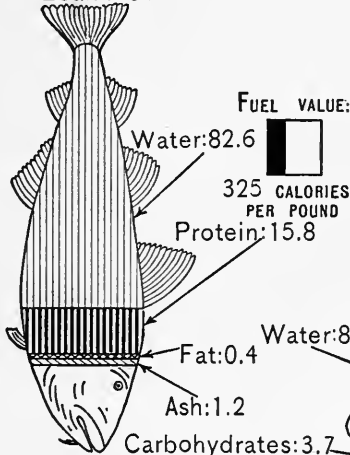

SALT COD

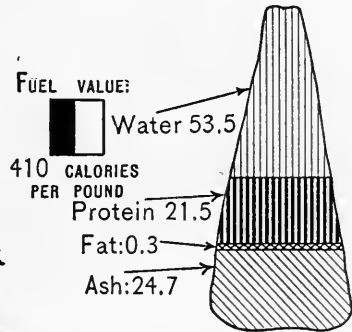

OYSTER

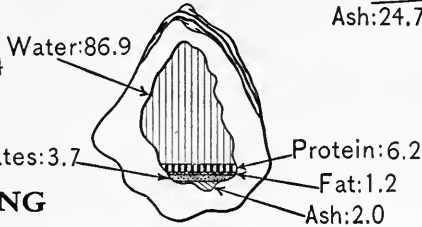

SMOKED HERRING

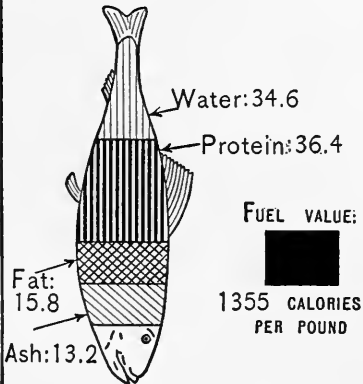

MACKEREL

Fat Fish

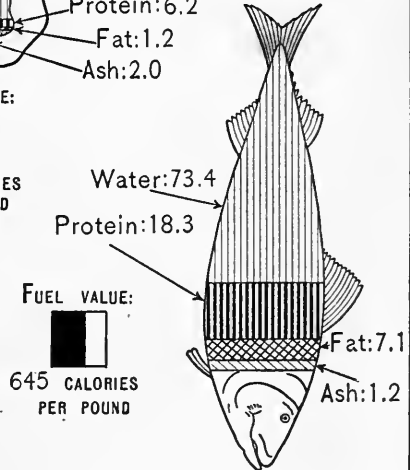

CHART 6.

mashed or finely chopped potato, and heat it as you would meat hash. The stuffing may be used with the fish in any of these dishes.

Why fish need special care in cooking. — The connective tissue of fish is more easily softened than that of meat. It is this that makes fish break so easily.

Except for fish so rich and oily that some loss of flavor and nutriment can be afforded, boiling is a wasteful way of cooking cut fish. Vinegar or lemon juice in the water hardens the fish, thus helping to keep it whole, and saves some of the albumin, by helping to coagulate it; but any fish is better steamed than boiled.

What other precautions do we take to keep fish from cooking to pieces, or from falling apart after being cooked? What effect has cooking on connective tissue?

Food value and digestibility of fish: methods of preserving it. — In food value and digestibility, fish is much like lean meat. It is cheaper per pound than meat, but the waste is large. As it is deficient in extractives, we tire of it sooner than of meat. It is desirable as a means of varying the diet, and it is the staple protein food in many coast towns where sea-food is cheap and meat hard to obtain.¹

Fish containing little fat, and that mostly in the liver, are termed "dry"; their flesh is usually white. In most dark-fleshed fish, fat is more abundant, and found throughout the body. Fish from warm waters are as a rule drier and poorer in flavor than fish from cold water.

¹ There is no truth in the popular notion that fish supplies the brain with phosphorus.

Fish does not keep as well as meat. To be at its best, it should be eaten soon after it is caught. Fish kept too long is watery when cooked.

A temperature below 32° F. is required to keep fish in good condition for more than a few days. Frozen solid, great quantities are now stored, sometimes for several months, and are shipped long distances. Frozen fish spoils quickly after thawing.

Dried, salted, and smoked fish lose much water in these curing processes, and so are more nutritious, pound for pound, than fresh. (Chart 6.) Canneries are established near fisheries, and quantities of fish, especially of salmon, are canned. Fish should not be left in the can after it has been opened. (See action of acids on metals, p. 57.)

A STUDY OF THE STRUCTURE OF AN OYSTER. (See Pl. XI.)

Examine an oyster from which the flat shell has been removed. Has it any bones? How is its body protected? Observe the thin membrane (*mantle*) covering the oyster; its fringed edges form the gills. Find on either shell a blue spot showing where the muscle is attached that opens and closes the shell; also the dark spot on the oyster where the liver is.

How the oyster lives. — Oysters, clams, mussels, and scallops are salt-water shell-fish belonging to the family of **mollusks**, or soft-bodied animals. Their shells, built up of mineral matter secreted by the mantle, form a sort of outside skeleton. The young oyster floats about, but as its shell grows thicker and heavier, it settles down on the sand or rocks, the half shell, or *valve*, on which it lies becoming rounder and deeper than the one that covers it. The

TABLE OF INFORMATION ABOUT FISH

SALT-WATER FISH						
KIND	APPEARANCE	LENGTH	WEIGHT	HOW SOLD	HOW PREPARED FOR EATING	
COD.	Color light green, with narrow white stripe down the side; spotted with darker color. Pointed barbel underneath the mouth.	2 to 6 feet.	2 to 100 pounds.	Small ones whole; large ones by the pound.	Boiled, baked, fried. (Salted.)	
HAD-DOCK.	Silvery color; similar in shape to cod; one black spot on either side near the head.	2 to 3 feet.	About 5 pounds.	Like cod.	Same as cod. (Smoked.)	
MACKEREL.	Silvery belly, with blue back; body slender.	About 12 inches.	Average 1½ pounds.	Whole.	Broiled. (Salted.)	
BLUE-FISH.	Back blue, belly light, head larger and back broader than in mackerel.	About 2 feet.	Average 4 pounds.	Whole.	Baked, broiled, fried, boiled.	
STRIPED BASS.	White belly; long parallel black lines on back; checkered between the lines.	Average 2 feet.	About 5 pounds.	Whole.	Broiled, baked, fried.	
HALLIBUT.	Flat fish with white belly and brown back. Eyes both on same side of head.	3 to 6 ft.	3 to 300 pounds.	By the pound.	Boiled, fried. (Smoked.)	

WEAK-FISH.	White belly; checkered blue and gray back. Yellow breast-fins.	About 2 feet.	Average 4 pounds.	By the pound.	Broiled, baked.
SMELTS.	Back silvery.	6 inches.	1 to 2 ounces.	By the pound.	Fried.
FRESH-WATER FISH					
WHITE-FISH.	White except a narrow stripe along back.	About 2 feet.	About 3 pounds.	By the pound.	Boiled, baked.
PERCH.	Silvery, with dark line along the back; yellow fins.	Average 9 inches.	About $\frac{3}{4}$ pound.	Whole.	Broiled, fried.
BLACK BASS	Body broad for its length; back green.	About 18 inches.	About $1\frac{1}{2}$ pounds.	Whole.	Broiled, baked, fried.
FISH FOUND IN BOTH FRESH AND SALT WATER					
SALMON.	Silvery, dark line along back, spots near head. Flesh pink.	2 to 3 feet.	Average 9 to 10 pounds.	By the pound.	Boiled. (Smoked.)
SHAD.	Back dark; scales large and silvery.	About 2 feet.	About 5 pounds.	Whole.	Broiled, baked, planked.

oyster has neither head nor limbs, but has a mouth near the hinge-end of its shell, and two strong muscles, one to open the shell to take in food and water, the other to close it, if a starfish or other enemy comes by. Oysters grow crowded together, forming *oyster-beds*.

Like fish, oysters are cultivated. Baby-oysters, called "seed-oysters," are planted all along the Atlantic coast. Oysters are not good for food when spawning. They spawn in summer, but not all at one time. It is customary, however, not to eat them during warm weather.

Great quantities of oysters are canned, especially for use in the West and Middle West.

Experiment. — Boil a little oyster liquor. What forms on top? What foodstuff do oysters evidently contain? At what temperature, and for about what length of time, would you cook them?

Preparation of oysters. — Oysters are commonly opened by the fish-dealer. To clean oysters, drain off the liquor, straining it through a wire strainer if it is to be used. Rinse the oysters on a colander, using only half a cupful of cold water to one quart of oysters, to avoid washing away the flavor. With the fingers examine the gills to see that no bits of shell are left clinging to them.

How to serve raw oysters. — Oysters are served raw with lemon as a first course at luncheon or dinner. Horse-radish sauce or ketchup may be served with them. Arrange six oysters "on the half shell," on crushed ice on each plate, with the small ends toward the centre. Place a quarter of a lemon in the middle of the circle.

Oysters as food. — Oysters contain as much water as

milk does. Like milk, and unlike most other animal foods, they contain, besides protein, fat, and mineral matter, considerable carbohydrate.¹ Oysters are more or less salt according to the saltiness of the water they grow in. Their fuel value is little more than two-thirds that of milk. As they commonly cost five times as much as milk, they are an expensive food. (See charts 3 and 6.)

After being dredged up, oysters are often floated in shallow water for a day or two to free them from dirt and slime. This cleansing should be done in *pure* water about as salt as that they came from. If put into fresher water, they absorb it, swell up, and lose much of their salts and with these their flavor. People have contracted typhoid fever by eating oysters either grown or floated in water contaminated by sewage.

OYSTER STEW

Stewing oysters, 1 p.	Butter, 2 tb.
Hot milk, 1 c.	Salt.
Pepper, f. g.	

Drain and rinse the oysters, strain the liquor, and heat the oysters in it till their edges curl,² remove the scum, and turn oysters and liquid into the hot milk. Add butter and seasoning. Serve with oyster crackers.

SCALLOPED OYSTERS

Oysters, 1 pt., solid.	Salt, about 1 t.
Melted butter, $\frac{1}{2}$ c.	Pepper, $\frac{1}{4}$ t. or more.
Stale bread crumbs, 2 c.	Oyster liquor, or oyster liquor and milk, 5 or 6 tb.

¹ Glycogen, in the liver, which in the oyster is comparatively large (p. 142).

² If cooked longer, they will be leathery.

Mix the crumbs with the salt, pepper, and butter; spread one-third of them on the bottom of a buttered baking-dish; put in half of the oysters, drained and rinsed, another layer of crumbs, and the rest of the oysters; and cover the top with the remaining crumbs. Pour over these the liquid. Bake about twenty minutes in an oven hot enough to brown the crumbs in that time.

A grating of nutmeg or a slight sprinkling of mace may follow each layer, if you choose.

Other shell-fish.—Lobsters, crabs, and shrimps are *crustaceans*; that is, animals consisting of jointed sections, each of which is covered with a hard shell. Their flesh is similar in composition to that of other fish, but tough and hard to digest. It is liked because of its unique and delicate flavor.

BRIEF REFERENCE LIST

For further development of topics treated in this section see:—

SHERMAN: *Food products*. Ch. 7.

WARD: *Grocer's encyclopedia*. (Articles on fish, fish-culture, and under separate headings, cod, crabs, etc.)

U. S. DEPT. OF AGRICULTURE: *Farmers' bulletin*: 85. Fish as food.

U. S. DEPT. OF AGRICULTURE: BUREAU OF CHEMISTRY. Bulletin 133. Preparation of cod and other salt fish for the market. Illust.

BIGELOW: *Applied biology*. P. 358, Lobsters and other crustaceans; p. 405, Oysters and other mollusks.

SMITH: *Oysters*. National geographic magazine, v. 24, no. 3, March, 1913.

CHAPTER VII

FATS AND OILS

SECTION 1. FATTY FOODS

What foods have we found to contain fat? What uses have we made of fat in cooking? What are the uses of fat in the body? (Pp. 72, 140, 141.)

Distinction between fats and oils. — We know that fats and oils are alike greasy, and that fat, by heating, may be changed to oil. Some fats are soft and oily, others firm and hard. The softer a fat is the less heat it takes to melt it. An oil is a fat that is liquid at ordinary temperatures.

Most fats contain *stearin* and *palmitin*, solid fatty substances, and *olein*, a liquid. The more stearin fat contains the harder it is. Oils consist chiefly of olein, in which some palmitin and stearin are dissolved.

Vegetable fats and oils. — The fat of most plants is in the form of oil. Cocoa-butter is an exception. (P. 345.) Seeds, particularly nuts and kernels of grains, are rich in oil, stored up, as starch is, to feed the seedling. Olive oil is extracted by pressure from the fruit of the olive tree. Olives are about the size of plums. Some varieties, when ripe, are purple, some green, others yellow. The best oil is obtained from the first pressing of fresh, carefully picked fruit; a

U. S. Department of Agriculture
Office of Experiment Stations
A. C. True: Director

Prepared by
C. F. LANGWORTHY
Expert in Charge of Nutrition Investigations

COMPOSITION OF FOOD MATERIALS.

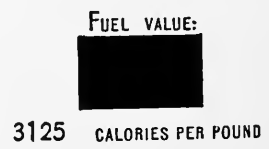
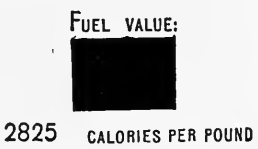
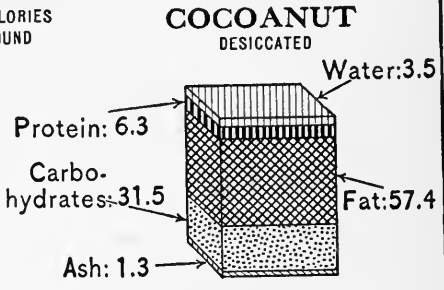
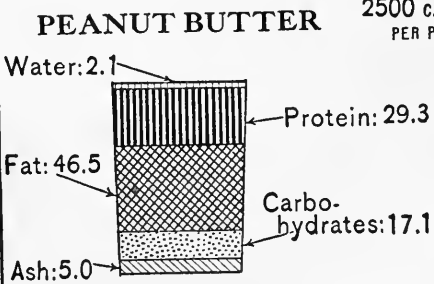
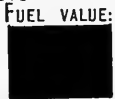
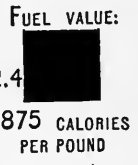
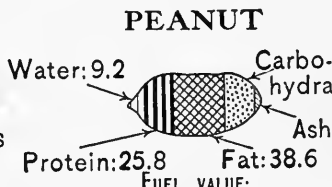
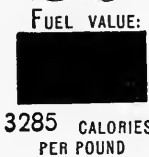
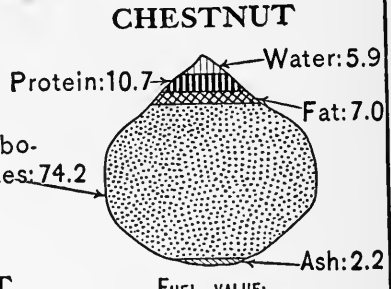
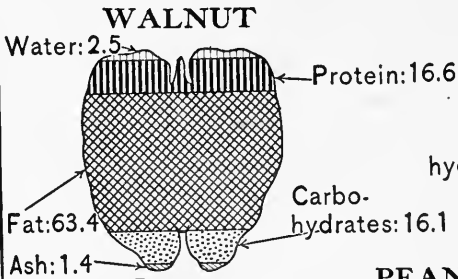

CHART 7.

poorer grade, from a second pressing; and after treating the mass of pulp with hot water, or with chemicals, a third grade, used for soap-making.

Cottonseed oil is as nutritious as olive oil, but inferior in flavor. The cottonseeds are first chopped, hulled, rolled, and cooked. Then they are put in bags and the oil is pressed out. Oil for table use is refined. The mass of seeds left, called "oil-cake," makes good cattle food. Cottonseed oil mixed with suet and other fats forms a lard-like substance sold under various trade-names for frying and shortening.

Oils from other seeds and nuts, corn, peanuts, cocoanuts, rape, sesame, and others are used for food.

Nuts, generally speaking, are rich in fat and contain considerable protein and ash, but not much starch. They are a concentrated food and should be eaten as a part of the diet, not as an extra tid-bit. Peanut butter and other nut-pastes are desirable foods.

Animal fats. — Butter and lard are the animal fats most commonly used for food. Butter-fat seems to contain something which makes it more useful in the body than lard or vegetable oils. It is the most palatable of raw fats, and therefore can be taken into the body in large quantities. (For butter, see pp. 99–101; for lard, p. 182.)

Butterine (*oleomargarine*) is a substitute for butter made from a mixture of animal and vegetable fats churned with milk. A little genuine butter is usually added to flavor it. Butterine is wholesome and a better article of food than most so-called "cooking-butter," but less palatable and less desirable for steady use than good butter.

Food value of fat. — We have learned that fat has a fuel value more than twice as great as that of protein or carbohydrate. (See Carbohydrates, p. 72 and Food requirements, p. 146.) This is why we incline to eat more of it in cold weather than in warm, why Esquimaux and Arctic explorers enjoy whale-blubber and walrus-fat. But theoretically we could do without it. The body does not use fat exclusively for fuel, and if no fat were supplied, it would merely have to burn more carbohydrate and protein. Fat is more expensive than carbohydrate. Yet everywhere, even in hot countries, it forms part of the diet. There are two reasons for this besides its high fuel value. First, it does not require much digestion. (See What digestion is, p. 366.) Second, fat is readily stored in the body. (P. 142.) If any protein or carbohydrate has to be stored, a good deal of work must first be done on it by the body.

Cooking as it affects the digestibility of foods containing fat. — If not properly cooked, fat may make more work for the body than it saves. Fat itself is most readily digestible when finely divided, as in milk, or in such form that it can be quickly divided, as in crisp bacon. Instinctively we prefer to spread butter on bread, and in general, to eat fat in combination with other food. But it is not well to incorporate it so closely with other food that particles of this are coated with grease, as in toast soaked with melted butter, or in fried food that has soaked up fat. In this case the fat, since it is not affected at all by saliva and but little by gastric juice, tends to act as a seal, and prevent these juices from reaching the starches and proteins in the food.

U.S. Department of Agriculture
Office of Experiment Stations
A.C. True: Director

Prepared by
C.F. LANGWORTHY
Expert in Charge of Nutrition Investigations

COMPOSITION OF FOOD MATERIALS.



OLIVE OIL

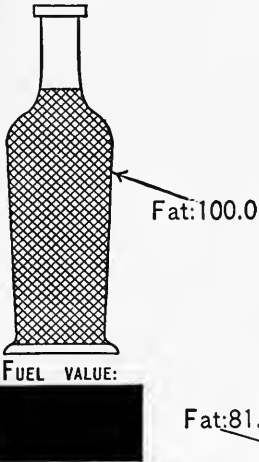

4080 CALORIES PER POUND

BACON

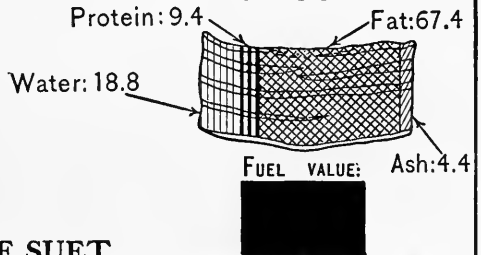

3030 CALORIES PER POUND

BEEF SUET

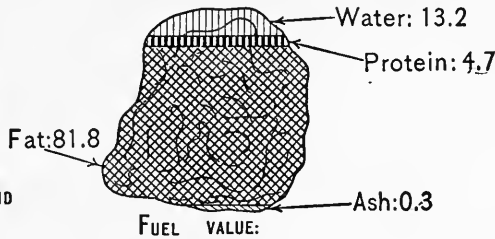

3510 CALORIES PER POUND

BUTTER

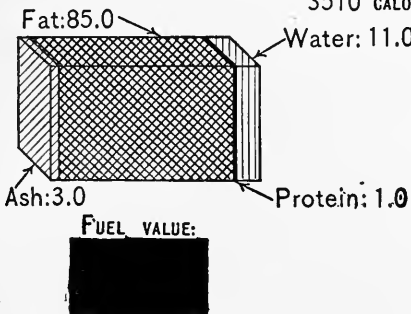

3410 CALORIES PER POUND

LARD

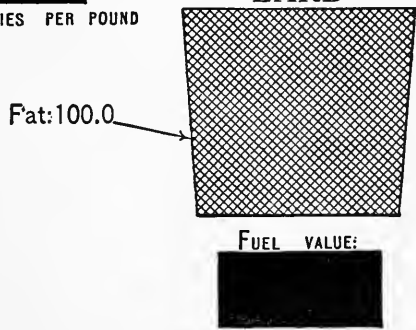

4080 CALORIES PER POUND

CHART 8.

These, therefore, run the risk of remaining undigested until the fat is removed from them in the intestine, and may never be thoroughly digested and absorbed. With pastry the case is still worse, for in this not only is shortening so rubbed into the flour that it may envelop starch-granules, but so little water is added that these cannot swell as they should. If pastry is to be made at all, pains should be taken to have it light and crisp. Burned fat contains indigestible and irritating substances.

Directions for cooking bacon. — Have the bacon sliced as thin as possible. Provide a jar or small bowl for the fat which will cook out of the bacon, and a pan with several thicknesses of brown paper laid on it for draining the bacon. Heat the frying-pan, and put the bacon in. As the melted fat accumulates, pour it into the jar. Turn the bacon with a fork. Remove as fast as it is done and drain on the paper before placing on hot platter. The bacon should be crisp, but not scorched. If a great deal of smoke begins to rise from the pan during cooking, reduce the heat.

SECTION 2. COOKING IN FAT: FRYING AND SAUTÉING

The difficulty of cooking food in fat without having it greasy makes this the least desirable method of cooking. Nevertheless, certain kinds of food are good fried, and, if properly fried, need not be unwholesome.

Experiments with heated fat. — A. Take the temperature of butter or drippings while it is foaming and bubbling over the fire. Heat it until it no longer bubbles, and take its temperature again. Is it hotter or cooler than before? Does water stop boiling unless it is allowed to

cool? Does it grow hotter after it reaches the boiling-point? Do you think the fat was boiling when it bubbled?

Why we should not speak of "boiling" fat. — Fats, generally speaking, burn before they boil. It is water contained in the fat that makes it bubble when heated. Until this water has boiled away, the fat cannot be raised to a temperature much above 212° , but after it has all passed off, as is shown by the fat becoming still, the latter grows rapidly hotter, rising to 300° or 400° , some kinds of fat even higher.

Experiments (continued). — **B.** Drop a bit of bread into bubbling-hot lard; after a minute take it out. Continue to heat the lard until it smokes and is perfectly still. Drop in another bit of bread, let it stay a minute, then take it out. Break open both pieces. Which piece has soaked up the most grease? Which has browned? How does a coating of grease affect the digestion of food? How does browning (*caramelization*) affect the digestion of starch? Should food be fried in bubbling or in still fat? What makes the fat bubble when the bread is dropped into it? How does moisture affect the temperature of hot fat?

C. Heat butter, lard drippings, and olive or cottonseed oil in separate sauce-pans. Which burns first? Which can be made hottest without burning? Which is best for frying? Which is least desirable?

Points about frying. — These experiments show (1) that unless fat used for frying is hot enough to form a crust on the food cooked in it, it will soak into the food; (2) that so long as it bubbles it is not hot enough to form a crust; (3) that anything that cools the fat tends to make the food greasy; (4) that the best fat to fry in is the one that can be made hottest without burning.

Therefore, do not use fat that burns easily; have the fat deep enough to cover the food, so that it may be crusted

over at once; see that it is smoking hot and still before putting the food in; reheat the fat after each frying.

Olive oil, which may be heated to above 600°, is the best fat for frying. Southern Europeans use it commonly. In this country the cheaper cottonseed oil, alone or combined with other fats, is much used. Of the animal fats, a mixture of one-third beef suet and two-thirds lard is the best for frying. Lard alone, being soft, is too easily absorbed by the food.

How to prepare fat for frying. — Fats are “tried out,” or *rendered*, to free them from connective tissue, then *clarified* to remove water and impurities. Fat for frying is now commonly bought ready for use, but if desired, suet may be bought for this purpose; all scraps of fat, cooked or uncooked, and drippings from beef, veal, fresh pork, and chicken¹ may be saved and used also. Soup fat and drippings need only to be clarified; suet and scraps must first be tried out.

To try out fat. — Cut the fat into bits, put it into a frying-pan, or better, a double boiler, and let it cook slowly for several hours. When the fat is melted, and nearly free from water, strain it, pressing to obtain all the fat.

To clarify fat. — Melt drippings or tried-out fat, add to it a few slices of raw potato, and heat slowly in the oven until it ceases to bubble. The potato absorbs some of the impurities; most of the rest settle to the bottom. Strain

¹ The flavor of fat from mutton, lamb, duck, goose, and turkey prevents their being used in cooking. They may be saved for soap-grease. The fat from smoked meats may be used for frying, if you do not object to its taste.

the fat through cheese-cloth, and let it stand undisturbed till solid. If stirred, it absorbs moisture from the air. Since it keeps longer if left unbroken, it is well to strain it into cups or marmalade jars, so that a portion may be used without disturbing the rest.

Foods suitable for frying are those made of cooked material or those that require little cooking; for example, croquettes and oysters. Most raw food, in order that the outside may not become too brown before the inside is cooked, must be put into fat not quite so hot as it should be to prevent absorption of grease. *Exceptions.*—Fish and oysters, being very watery, cool the fat rapidly; make it therefore as hot for these as for cooked articles.

Articles of food to be fried are usually covered with egg and crumbs, flour, or meal, to protect them from absorbing fat. Why is egg used for this purpose?

Testing the temperature of fat for frying.—When the fat begins to smoke, drop into it an inch cube from the crumb of white bread. If this becomes golden brown in forty seconds, the fat is right for croquettes and other articles made of cooked material, and for fish and oysters. If it takes sixty seconds, it is right for fritters, and most other uncooked articles.

Directions for frying.—Use a deep frying-pan or kettle. A wire frying-basket to hold the articles to be fried, hung on a long-handled fork, is convenient; but they may be lowered into the fat and taken from it with a spoon-shaped wire egg-beater. Put the fat into a cold kettle, and bring it slowly to the right degree of heat. Have ready several

sheets of soft paper laid on a pan, also a pan to hold under the food as it is taken from the fat. Test the fat; if right, dip the basket or wire spoon into the fat to heat and grease it. If a basket is used, lay three or four articles in it, and lower them till the fat covers them. When they are a delicate golden brown, lift the basket, shake it a little, and let the food drain for a moment before removing it to the paper. Reheat the fat, testing again if necessary, and fry another batch of articles. Three croquettes can be fried at once in a three-quart saucepan; more will cool the fat below the "soaking-point." When all grease has been absorbed by the paper, arrange the food on a platter, and garnish it with parsley; in the case of fish or oysters, with parsley and slices of lemon.

CROQUETTES

Materials used. — The usual croquette mixture consists of two parts of chopped cooked meat, or cooked, flaked, well-seasoned fish, to one part of thick white sauce. Cheese, macaroni, and some kinds of vegetables may also be used in croquettes.

Shaping and crumbing. — Put on a board a heap of fine, dried bread crumbs. Break an egg into a plate, add it to a tablespoonful of water, and beat it enough to mix the white and yolk. With two spoons, or with spoon and spatula or broad-bladed knife, shape heaping tablespoonfuls of the croquette mixture into balls, roll them in crumbs, shape them into cylinders or cones,¹ and with the knife lift

¹ Cones are easily shaped with an ice-cream dipper.

them one by one into the egg, dipping it over them till every bit of the surface is covered; roll them in crumbs again till all the egg is covered, and lay them carefully on the board.

POTATO CROQUETTES

Mashed or riced potato, 2 c.	Pepper, $\frac{1}{8}$ t.
Butter, 2 tb.	Celery salt, $\frac{1}{4}$ t.
Salt, $\frac{1}{2}$ to $\frac{3}{4}$ t.	Onion juice, 10 drops.
Yolk of 1 egg.	Finely-chopped parsley, 1 t.

Beat the yolk, mix it with the potato, and add the other ingredients. Heat the mixture in a saucepan, stirring; when it cleaves from the side of the pan, turn it upon a flat dish; when cold, shape it into cylinders about three inches long. Roll these in egg and crumbs and fry them.

CHICKEN CROQUETTES

Cooked chicken, chopped fine, 2 c.
 Thick white sauce, 1 c.
 Onion juice, 1 t.
 Grated nutmeg, f. g. (about three strokes on the grater).
 Additional salt and pepper according to taste.

Make White Sauce for Croquettes from

Butter, 2 tb.	Milk or thick cream, 1 c.
Flour, $\frac{1}{4}$ c.	Salt, 1 t.
	White pepper, $\frac{1}{8}$ t.

Add seasonings to the chicken, mix with the hot white sauce, and pour upon a platter to cool. When cold, form into cylinders or cones, roll in egg and bread crumbs, and fry in deep fat. Serve on a folded napkin, or pour around them a white sauce. Garnish with parsley.

Croquettes may be made of any cooked meat. With beef or lamb croquettes omit nutmeg, and serve with Tomato Sauce instead of White Sauce.

SAVORY RICE CROQUETTES

Boiled rice, 2 c.	Salt, $\frac{1}{2}$ t.
Eggs, 1, beaten.	Pepper, $\frac{1}{8}$ t.
Butter, 2 tb.	Cayenne, or paprika, f.g.
Minced parsley, 2 or 3 tb.	

If the rice is cold, warm it with two or three tablespoonfuls of milk. Mix the ingredients, and shape and fry like chicken croquettes.

CODFISH CAKES (FISHBALLS)

Salt codfish, $\frac{1}{2}$ lb.
Potatoes, in inch-thick pieces, 2 hp. c.
Eggs, 1.
Butter, $\frac{1}{2}$ tb.

Boil and mash the potatoes. While they are cooking, cover the codfish with boiling water; when this is cool enough to allow your hands in it, pick the fish into shreds. Drain off the water, mix fish, potatoes, butter, and egg together, and beat the mixture well. Fry it by heaping tablespoonfuls in deep fat, or shape it into balls or cylinders and fry in deep fat.

DIRECTIONS FOR FRYING OYSTERS

Clean large oysters as directed on p. 210; lay them on one end of a soft cloth, and with the other pat them dry. Take them one at a time by the gills; cover them first with

seasoned cracker crumbs, then with egg, and last with crumbs grated from loaf. Fry in fat hot enough to brown white bread in forty seconds.

SAUTÉING

Sautéing, often incorrectly called "frying," is cooking in a small quantity of fat. It is a slower method than "deep frying," less healthful, because the food cannot be kept from absorbing grease, and more wasteful, on account of the fat taken up in this way. But, as it is sometimes convenient to sauté potatoes, liver, small dry fish, and a few other kinds of food, it is important to know how to do it in the best way.

Directions for sautéing. — Have the pan hot enough to hiss when the fat is put into it, and the fat hot enough to hiss when the food is put in. Cook the food first on one side, then on the other. Use very little fat, adding from time to time just enough to keep the food from burning.

The very worst way of cooking food is to put it into a cold or half-warm pan with grease enough to half cover it, and to let it sizzle and soak till it is wanted. Such food is unfit to eat.

SUGGESTIONS ABOUT USING FAT IN COOKING

1. Save all bits of butter from the table to use in cooking.
2. It is often well to substitute a cheaper fat, wholly or in part, in recipes calling for butter. Good cake can be made with butterine, chicken-fat, or part butter and part lard. Beef fat is a good substitute for butter in shortening bread, biscuits, and gingerbread.

3. Have articles to be fried as dry as possible, and not very cold. Why?

4. *Cautions.* — Always lower food gently into hot fat; if the food is dropped in, the fat, splashing up, will burn your hand, and may fall on the stove and catch fire. If this happens, or if the fat in the kettle takes fire, throw sand or ashes or flour on it. With care about spattering the fat, or spilling water into it, which causes a sudden burst of steam, there need be no accidents.

5. When the frying is done, remove the fat from the fire at once. Strain it through double cheese-cloth.

6. When fat has become dark from repeated using, clarify it with potato or pour into it, when cold, three or four times its bulk of boiling water, stir well, and let it cool. Remove the cake of fat, and scrape off the sediment that will be found on its under side. Fat too dark for croquettes may be used for fish. From overheating, or many times reheating, it becomes unfit for cooking purposes. When you find it does not brown the food well, use it for soap-grease or throw it away.

BRIEF REFERENCE LIST

For further development of topics treated in this section see:—

SHERMAN: *Food products.* Ch. 9 and 10.

OLSEN: *Pure foods.* Ch. 6 and ch. 7 to p. 74.

WILEY: *Foods and their adulteration.* Ch. 7.

WARD: *Grocer's encyclopedia.* (Articles on olives, olive-oil, peanuts, peanut oil, oleomargarine, etc.)

U. S. DEPT. OF AGRICULTURE: *Farmers' bulletins:* 431. The peanut; 322. Nuts and their uses as food.

CHAPTER VIII

FRUITS AND VEGETABLES

SECTION 1. FRUITS

A STUDY OF AN APPLE

Apples may be said to be to other fruits what potatoes are to other vegetables. But what do we know about apples? For instance, what makes them hard? Grate and squeeze one as you did the potato, and you will know. So much juice must mean that the apple is full of water. Test it for starch (p. 61). Taste it. It tastes both sour and sweet. What two substances must it contain? In talking of the pulp of the apple, as the mass of juice-filled cells is called, we must not forget that this grows simply as a covering for the seeds. Some fruits have stones enclosing their seeds. How many stone fruits can you name? In some others the seeds are scattered through the pulp. This is true of some foods not commonly called fruits; for example, the tomato, the squash, the cocoa bean.

Definition of fruit; popular use of the term. — In the broad sense, all seed-vessels are fruits. This definition covers nuts, grains, and many vegetables; but we commonly class as fruits those seed-vessels eaten with sugar or as a

U. S. Department of Agriculture
Office of Experiment Stations
A. C. True: Director

Prepared by
C. F. LANGWORTHY
Expert in Charge of Nutrition Investigations

COMPOSITION OF FOOD MATERIALS.

 Protein

 Fat

 Carbohydrates

 Ash

 Water

 Fuel Value
1/16 Sq. In. Equals
1000 Calories

APPLE
EDIBLE PORTION

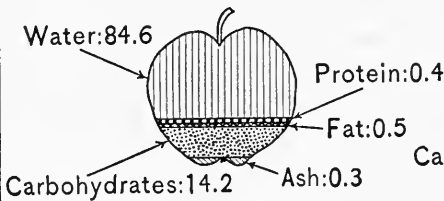

FUEL VALUE:  290 CALORIES PER POUND

DRIED FIG
EDIBLE PORTION

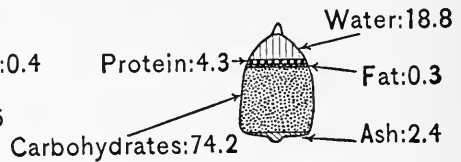

FUEL VALUE:  1475 CALORIES PER POUND

STRAWBERRY
EDIBLE PORTION

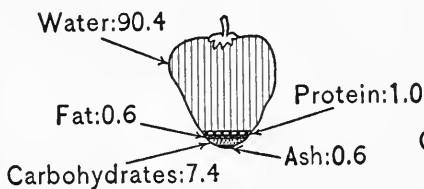

FUEL VALUE:  180 CALORIES PER POUND

BANANA
EDIBLE PORTION

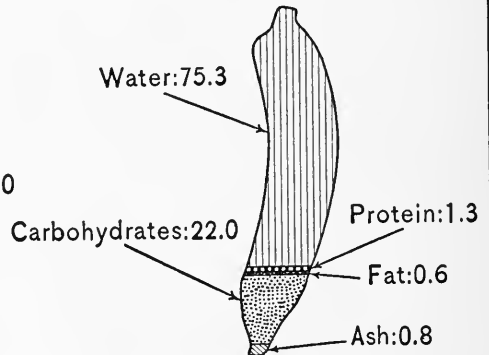

FUEL VALUE:  460 CALORIES PER POUND

CHART 9.

dessert; and as vegetables, those served with meat or in salads. Fifty years ago, when it was the custom to eat tomatoes with cream and sugar, they were doubtless considered fruit.

Composition and food value of fruits. — The edible portion of most fresh fruits contains from 80 to 90 % of water and considerable cellulose. They have almost no protein nor fat, and, when ripe, little or no starch. Ripening changes their starch to sugars and gums. Many fruits and some vegetables contain "pectin bodies," resembling carbohydrates. Whether these have any food value is not known. (See Pectin, pp. 304–305.) Sugar is the only foodstuff found in any considerable quantity in fruit. Apples, cherries, pears, peaches, and oranges contain, on an average, about the same amount of sugar (7 to 14 %); lemons, cranberries, and currants, less; grapes, and bananas, and dried fruits, more.

Excepting bananas, fresh fruits have little fuel value. We eat them for their delicious taste, their refreshing, thirst-quenching juices, and the important mineral compounds they supply, including those of calcium, magnesium, potassium, phosphorus, and iron. They are base-formers, and so help to prevent bad results from eating meat. (See p. 143).

Bananas contain more carbohydrates than other fruits do. In ripe bananas these are mostly in the form of sugar and gum, but the bananas in our markets, like all fruits sold far from where they are grown, are picked green, and never ripen as perfectly as they would on the tree. In this

condition they contain considerable starch, and, therefore, need cooking to develop all their food value and flavor.

Fruits in southern markets. — Some fruits grown in the South and Southwest are rare in Northern markets. Among these are fresh figs. These are peeled and eaten with or without cream, or are made into jam. Guavas, and loquats, a small downy yellow fruit, are eaten either raw or cooked. Logan-berries, a California product, are a cross between raspberries and blackberries. They are very acid, but make good jelly.

Some pineapples come from Florida, but more are imported. Pineapples contain a digestive ferment.

SUGGESTIONS ABOUT EATING FRUIT

1. Fruit, fresh, canned, or dried, should be used daily. It is not fruit, but bacteria in fruit not in proper condition that causes sickness.

2. Eat only sound, ripe fruit raw. Fruit slightly under-ripe or over-ripe may be made safe to eat by cooking. Cooking softens the fibre and kills bacteria.

3. Sweet fruits, such as dates, figs, or prunes, may be eaten instead of sugar with cereals. It is better not to eat acid fruit and starchy foods together, as acid tends to delay the action of saliva on starch.

4. Do not eat peach, plum, or any other tough fruit-skins. It is safer not to eat grape seeds. Chew raw huckleberries well. Young children and others with whom fruit containing small seeds does not agree, may take the juice of such fruits.

Home-made fruit-juice, fresh or canned, makes better drinks, especially for children, than the soda-fountain supplies.

HOW TO PREPARE AND SERVE FRESH FRUIT

Fresh fruit must be clean. — Fruit and vegetables exposed for sale on the streets and sidewalks gather dirt, besides decaying quicker than they would if kept protected and cool. The law should require dealers to keep these foods indoors and covered. In some cities women have been instrumental in having such a law enforced. Ordinarily, fruit bought in the market must be rinsed or wiped clean. Rinse berries quickly in cold water and drain them at once. Soaking hurts their flavor and softens them.¹ Rinse grapes and other small fruits. Wipe larger fruits with a damp cloth. If you like apples polished, rub them with soft paper. Wipe the down from peaches.

Use silver or wooden spoons, silver knives, and earthen or enamelled cooking dishes for fruit. What class of substances in fruit may form bad-tasting, and perhaps poisonous, compounds with iron, steel, or copper? (P. 57.)

Serving fruit. — Fruit, except when fresh from tree or vine, should be served as cold as possible. Never leave fruit in the dining-room between meals; keep it cool and out of the dust. Arrange it tastefully, grouping the colors harmoniously, if several kinds are placed on one dish. Place finger bowls on the table when fruit is served. Fruit juice stains white napkins.

¹ Strawberries are never so good after washing. Use as little water as possible on them.

Sugaring fruits. — Cut and sugar sliced peaches just before serving, as they discolor quickly. Let sliced oranges, bananas, and pineapples stand sugared for half an hour. Sugar currants, crush them slightly, and let them stand till the sugar dissolves. Serve berries unsweetened, and pass powdered sugar, or sugar and cream, with them.

Oranges. — For breakfast, oranges are served whole or cut in halves across the sections. To prepare sliced oranges, peel them, pick off the bitter, indigestible white skin, thrust a fork into the centre of the orange, and, with a sharp steel knife, slice off the pulp, leaving the pith on the fork. Sprinkle with sugar. **Orange-juice** may be served in small glasses. Cut oranges in halves, extract the juice, preferably with a glass lemon-squeezer, and strain.

Bananas. — Bananas peeled, scraped, and sliced may be served mixed with sliced oranges or by themselves with sugar and a little lemon juice or with sugar, a few grains of salt, and cream.

Melons, cantaloupes, and grape-fruit. — These may be a first course at breakfast or lunch. Cut grape-fruit in half, loosen the pulp from the skin of the sections with a knife, remove seeds and tough centre, and sprinkle with sugar. Cut melons or cantaloupes in two, remove seeds, and serve very cold. Ice may be placed in each.

Pineapple. — To prepare pineapple for the table, cut off the skin and dig out the eyes; then, holding the pineapple by the top, with a fork tear the pulp into shreds, and cut or scrape the shreds off with a knife, leaving the woody core untouched. Sprinkle with sugar.

COOKED FRUIT

Cooked fruit may be served at any meal. It is one of the best and most wholesome of desserts.

Fruit loses some of its sweetness in cooking. All fruits, except the sweetest, require, when stewed, the addition of sugar. Figs and prunes are so sweet that a little lemon juice improves them.

Directions for stewing fruit. — Cut pears, apples, or quinces in pieces. Slice or shred pineapples. Cook small fruits whole. Put into a saucepan half as much water as you have fruit. Add for each pint of fruit one-fourth to one-half cupful of sugar, according to the acidity of the fruit. When the sugar and water boil, put in the fruit. If enough juice does not flow to make the syrup cover the fruit, add boiling water until it does. When the fruit is soft, but not mushy, taste it; add more sugar if needed; stir until this dissolves; then take out the fruit. If the syrup is watery, boil it down before pouring it over the fruit. Fruit not quite ripe, or hard fruit such as quince, should be cooked in clear water till soft, and then sweetened.

APPLE SAUCE

Prepare sour apples, as for stewing. Put them into a saucepan with enough water to keep them from burning. Cook till the apples are very soft. Stir or beat to make the sauce smooth. Add one cupful of sugar to six or eight apples. If the apples lack flavor, cook an inch of stick cinnamon or five or six cloves with them.

BAKED APPLES

Wash and core large, sound, tart apples; put them into an earthen or enamelled baking-dish. Put one tablespoonful of brown sugar into each cavity, and pour boiling water into the dish, one-half cupful for each eight apples. Bake until soft, frequently dipping over the apples the syrup that forms in the pan. Serve cold with cream or milk. If the apples are thick-skinned, pare them after coring, that they may not be broken by knife or corer. If they lack flavor, add a little lemon juice and cinnamon to the sugar — one teaspoonful of lemon juice and one-fourth teaspoonful of cinnamon to one-fourth cupful of sugar.

Apples may be pared before baking and served in the dish in which they were cooked.

Pears, quartered, are baked or stewed like apples.

BAKED BANANAS

1. Choose sound, ripe bananas; cut about three-fourths of an inch off each end, and bake in an earthen or enamelled baking-dish for thirty minutes. Slit open the skin and eat the banana, which should be sweet and juicy, with a fork or spoon.

2. Remove bananas from skins, lay in a baking-dish, sprinkle with granulated sugar, and pour a little cold water into the dish. Bake in a hot oven until tender. Serve for breakfast or, with Lemon Sauce, for dessert. (For Lemon Sauce, see p. 282.)

CRANBERRY JELLY

Cranberries, 1 qt.

Water, 2 c.

Sugar, 1 lb.

Pick over and wash the cranberries, cook them slowly with the water for about fifteen minutes, and press through a strainer. Return to the fire, and add the sugar, stirring until it is dissolved. Boil without stirring five minutes longer, pour into a mould, and let it stand until firm enough to turn out. Serve with poultry, mutton, or game.

LEMONADE

Lemon juice, $\frac{1}{2}$ c.

Water, 1 qt.

Sugar, 1 c.

One way. — Mix lemon juice and sugar, add the water, and stir until the sugar dissolves, strain, and ice.

The best way. — Have the water boiling, pour it on to the lemon juice and sugar, strain, and, when cold, ice.

RHUBARB SAUCE

The stalk of rhubarb is so like fruit in composition that it is used as fruit is.

Steamed. — Cut off the leaves. Wash the stalks, cut into one-inch lengths, and cover with boiling water. After one minute pour off. To each pint of rhubarb add one-half cupful of sugar, and cook it in a double boiler till soft. Do not stir it. The pieces of rhubarb should be unbroken. A little water may be added if a juicier sauce is liked.

Baked. — Prepare and sweeten the rhubarb as for steaming. Cook it in a deep dish in a moderate oven until tender and deep-red in color.

Dried fruits. — Prunes are a kind of plums dried. Raisins are dried grapes. California supplies us with prunes and exports many besides. Of our raisins and figs, some are from California, some imported. Most of our dates are from Arabia, but date-palms are beginning to be cultivated in California and Arizona. California figs are cleaner than imported figs and free from worms. California dried peaches and apricots are sun-dried, but elsewhere they are evaporated, as apples are, by artificial heat in vacuum-pans. *Dehydrated fruits* and vegetables are prepared by a secret process superior to other methods of drying. After soaking, dried fruits are cooked as fresh fruits are. Dehydrated fruits may be cooked without soaking.

Imported dried fruits, unless fancy packed, are usually dirty, and should be rinsed with boiling water.

We might well eat more raisins, dates, and prunes than we do. They supply both fuel and mineral matter at moderate cost besides having value as base-forming foods. (See acid-forming and base-forming foods, p. 143.)

STEWED PRUNES

Prunes, 1 lb.

Sugar, 2 tb.

Lemon, 1, sliced.

Wash the prunes, and soak them for several hours, or overnight, in cold water enough to cover them. Add sugar and lemon, and cook them thirty minutes, or until soft. Or omit the sugar, and cook by moderate heat one hour or longer to develop the natural sweetness in the fruit.

BRIEF REFERENCE LIST

For further development of topics treated in this section see:—

SHERMAN: *Food products*. Ch. 9.

BIGELOW: *Applied biology*. Ch. 8, Studies of seed-plants.

SNYDER: *Human foods*. Ch. 4.

SNELL: *Household chemistry*. (Especially ch. 38, Foods of vegetable origin.)

WARD: *Grocer's encyclopedia*.

U. S. DEPARTMENT OF AGRICULTURE: *Farmers' bulletins*: 293. The use of fruit as food; 175. Home manufacture and use of grape-juice; 198. Strawberries; 213. Raspberries; and others.

U. S. DEPARTMENT OF AGRICULTURE: Reprints from year book: 1900. No. 218. The date-palm and its culture (good pictures); 1902. No. 281. Grape, raisin, and wine production in the United States (many good pictures); No. 354. Some uses of the grapevine and its fruits; 1912. No. 610. Raisins, figs, and other dried fruits; and others.

SECTION 2. VEGETABLES

We eat as vegetables the fruits, or seed-vessels, of some plants; of others the root, the leaves, or some other part.

Vegetables, like fruits, contain base-forming acids and mineral matter of nutritive value. What salts are found in potatoes? Vegetables valued chiefly for this mineral matter may be eaten raw; to this class belong lettuce, celery, cucumbers, and all "salad plants." Many vegetables, however, require cooking. If we analyze one, we shall see why.

STUDY OF A CARROT

Examine and analyze a carrot just as you did the potato, and make a table showing its structure and composition.

Is it a root or a tuber? ¹ Where is it most woody? In the spring you may be able to get both young and old carrots. Compare them. Which has the thicker skin? the more cellulose? The centres of very old carrots may be too hard to eat. Do carrots contain starch? Do you know or can you tell from their structure and composition which will take longer to cook, a potato, or a carrot of the same size?

Carrots contain more water than potatoes do; yet they are not good baked. Why?

Foodstuffs in carrots. — Carrots contain sugar, gum, and about one-fourth as much starch as potatoes do; of the mineral compounds in them the most important are potash salts, yet there are less of these than there are in potatoes.

How plants and animals make food ready for man. — Roots are the feeding organs of plants. They suck up water and food from the earth. We have seen that cattle turn grass into beef and milk for our use; grass, grain, and every edible plant that grows, work the mineral matter of the earth into cellulose, starch, sugar, for animals or men.

Analysis of peas. — **A.** Rub some cooked green or dried peas through a sieve, washing the pulp through with water. What is left on the sieve? **B.** Test for starch the pulp that passes through. **C.** Analyze beans in the same way.

Vegetables that supply protein: peas, beans, lentils. — We see that peas and beans may be considered starchy

¹ Roots of certain plants sometimes bud and sprout. Scoop out a carrot or a sweet potato for half its length; hang up this carrot or sweet-potato cup by a string; and keep it full of water. Sprouts will appear, but not from regularly placed eyes or *bud-scales*, as on potatoes or other *plant-stems*.

U. S. Department of Agriculture
Office of Experiment Stations
A. C. True: Director

Prepared by
C. F. LANGWORTHY
Expert in Charge of Nutrition Investigations

COMPOSITION OF FOOD MATERIALS.

 Protein

 Fat

 Carbohydrates

 Ash

 Water

 Fuel Value
1/8 Sq. In. Equals
1000 Calories

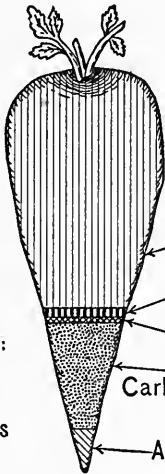

FUEL VALUE:

230 CALORIES
PER POUND

PARSNIP

POTATO

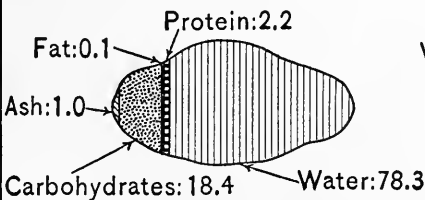

FUEL VALUE:

385 CALORIES
PER POUND

ONION

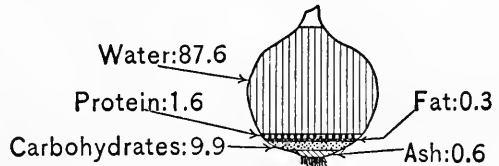

FUEL VALUE:

225 CALORIES
PER POUND

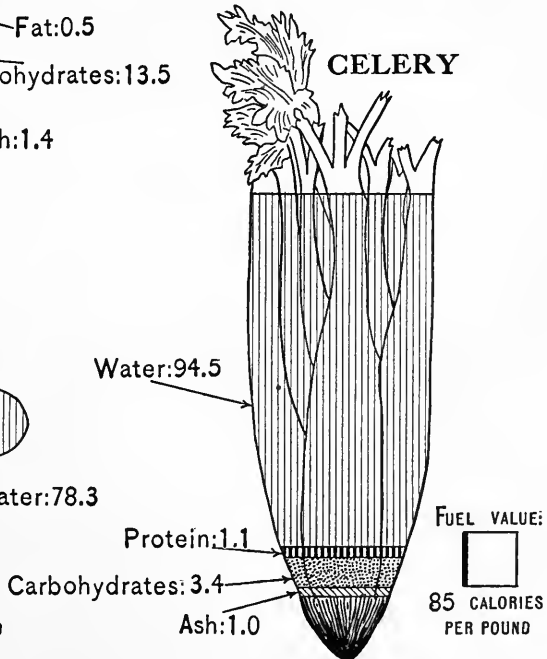
CELERY



FUEL VALUE:

85 CALORIES
PER POUND

CHART 10.

vegetables. But they also contain considerable protein, as is proved by their turning yellow if treated with nitric acid. In China a kind of cheese is made from them. This fact makes the name "vegetable casein," sometimes given to one of the proteins in peas and beans, seem appropriate. *Legumin* is, however, a better name for this substance. Although there are greater quantities of other proteins in peas and beans, they, together with lentils, are classed as *legumes*. (See chart 12, p. 245.)

STUDIES OF GROWING VEGETABLES

1. Make drawings of a pea-plant or a bean-plant at different stages of growth, noting how the two leaves that first appear (cotyledons) shrivel as the seedling grows. Explain this (p. 81).

2. **A.** Cover half an onion split lengthwise, with warm water, renewing this several times a day to hasten the experiment. What takes place in the centre of the onion, and at the base of the leaves? What becomes of the leaves as the shoot grows? Where does the onion store its food? **B.** Test the onion for starch.

An onion is a bulb, that is, an underground stem surrounded by overlapping leaves, thickened by stored-up food material.

Composition and food value of vegetables. — Vegetables, as a general thing, are watery and fibrous. The amount of fat in them is too trifling to be of any value. With the exception of the legumes, they contain little protein. Only a few have much carbohydrate. But all supply the body with those mineral compounds it requires. These are real tissue-building material, essential, though used in small quantities compared with other foodstuffs. Besides building tissue, they form alkalies (bases) in the body, which neutralize

U. S. Department of Agriculture
Office of Experiment Stations
A. C. True: Director

Prepared by
C. F. LANGWORTHY
Expert in Charge of Nutrition Investigations

COMPOSITION OF FOOD MATERIALS.



Protein



Fat



Carbohydrates



Ash



Water



Fuel Value
1/8 Sq. In. Equals
1000 Calories

GRAPES
EDIBLE PORTION

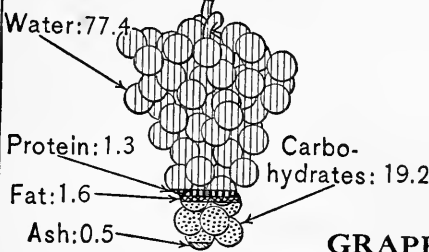

FUEL VALUE:



450 CALORIES
PER POUND

RAISINS
EDIBLE PORTION

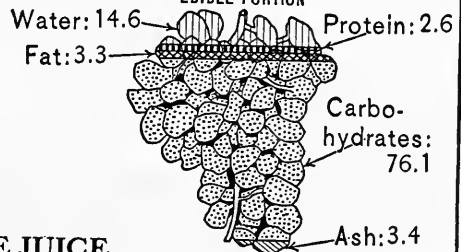

FUEL VALUE:



1,605 CALORIES
PER POUND

GRAPE JUICE
UNFERMENTED

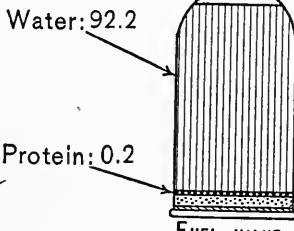

FUEL VALUE:



150 CALORIES
PER POUND

**CANNED
FRUIT**

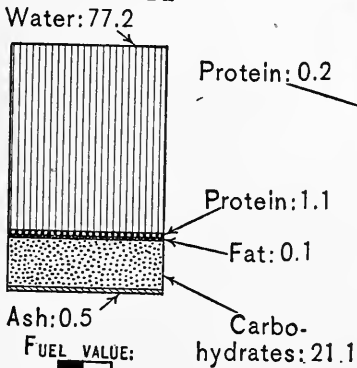

FUEL VALUE:



415 CALORIES
PER POUND

**FRUIT
JELLY**

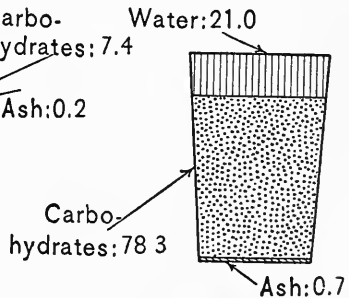

FUEL VALUE:



1,455 CALORIES
PER POUND

CHART 11.

acid produced by protein food. This is one reason why vegetables and meat go together so well. A potato is better than rice with a slice of beef, because it is a better base-former. (See acid-forming and base-forming foods, p. 143.) Potato is rich in potassium, spinach is rich in iron, parsnips are rich in phosphorus, other vegetables in calcium, and so on. But so little is known as yet as to the particular vegetables from which the body best obtains its supply of each element that it is best to provide the table with as great a variety as possible. Plant protein is less useful in the body than animal protein. More of it goes to waste, so that a given quantity of albumin from peas will not build as much tissue as the same quantity of egg-albumin.

Digestibility of vegetables. — The presence of cellulose in vegetables is thought to interfere with the digestion of the protein. Only a little of the cellulose eaten is digested and that slowly. So the cell walls may keep the digestive juices from reaching the foodstuffs enclosed in them. The more the cell walls are broken down, the more completely the vegetable is digested. The mineral matter in vegetables needs no digestion.

Cellulose adds bulk to the food and helps to keep the mass of digestible food loose. It also stimulates the movements of stomach and intestine.

Select vegetables with regard to the rest of the meal. — If you were to have both meat and fish for dinner, would you serve tomato or split-pea soup? What vegetables are suitable with roast beef? Which are suitable for a meal at which little or no meat is served?

Selecting vegetables in the market. — Choose vegetables that are in season. Those forced in hot-beds or brought from a distance are seldom equal to native produce, garden grown, — besides being too expensive for most purses. Know what each is worth when plentiful, and you will not be tempted to pay four or five times that sum for it out of season.

Choose medium-sized or small vegetables. Large vegetables are usually old and woody; they require more fuel to cook them than younger ones do, and are less nutritious. A measure holds a greater weight of small vegetables than of large ones — one reason why they ought to be sold by the pound. Large squashes and cucumbers are seedy; corn with large kernels is tough.

The signs of freshness and good quality in particular vegetables are given in the table on pp. 248–251. Stale or wilted vegetables are never economical, and are likely to be unwholesome.

If you get your vegetables from the garden, gather them while the dew is on them.

Care of vegetables. — Keep winter vegetables, except squashes, in a cool, dark, dry place, piled up to exclude air. Squashes keep better spread out in a rather warm, dry place. What grows on food in damp places? Keep green vegetables in the refrigerator or other cold place till used.

Preparation of vegetables. — 1. *Fresh.* Wash all fresh vegetables. Even if they look clean, they may have been watered with impure water, sprayed with insect poison, or have insect eggs on them. Soak in cold water vegetables

not fresh from the garden. How does water affect wilted flowers? In the same way it makes vegetables firm and crisp.

2. *Dried.* Dried peas and beans must be soaked to restore the water lost by evaporation. Weigh a pint of beans before and after soaking. What do they gain in weight?

3. *Canned.* As soon as the can is opened, turn out all the contents. Let all canned food stand awhile to regain the oxygen lost by canning. Heat, season, and serve like fresh vegetables.

HOW TO COOK VEGETABLES

Since most vegetables are eaten largely for the sake of the salts dissolved in their juices, it is a great mistake to think only about getting them soft, and not about saving these juices. Vegetables cooked in water lose a considerable quantity, not of salts alone, but of other foodstuffs, especially starch and sugar. It is better, therefore, to steam vegetables than to boil them, and to bake such as are tender enough to be good baked. Tasteless, dull-colored peas have lost food value as well as flavor and color. Vegetables when cooked right look and taste good. The directions for cooking vegetables given in the table on pp. 248-251 are based upon the following general rules:—

GENERAL RULES FOR COOKING VEGETABLES

1. Cook vegetables whole when practicable. When not practicable, cut them into as large pieces as are convenient. If the cooking water is to be served with the vegetable,

U. S. Department of Agriculture
Office of Experiment Stations
A. C. True: Director

Prepared by
C. F. LANGWORTHY
Expert in Charge of Nutrition Investigations

COMPOSITION OF FOOD MATERIALS.

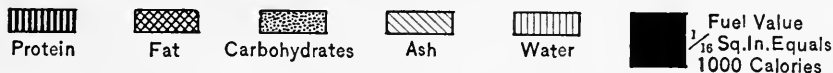

SHELLED BEAN, FRESH.

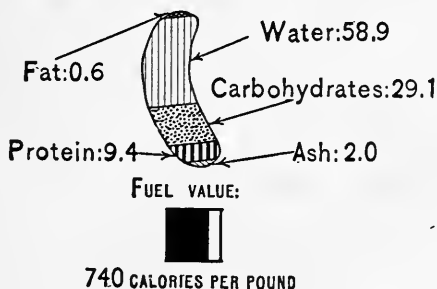

NAVY BEAN, DRY.

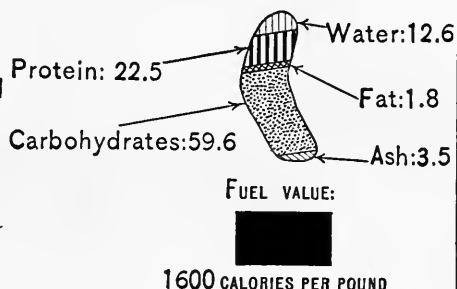

STRING BEAN, GREEN.

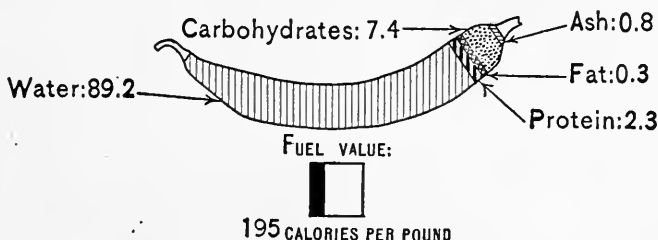

CORN, GREEN.

EDIBLE PORTION

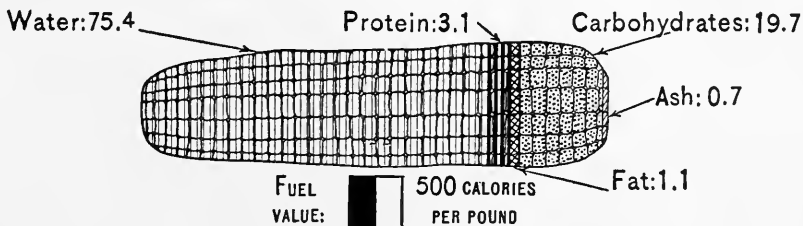

CHART 12.

the pieces may be smaller than would otherwise be desirable.

2. Use only as much water as is necessary to cover the vegetable. For small or cut-up vegetables that can be stirred, use just enough to keep them from burning, adding more as this cooks away.

3. Use the cooking water, if palatable, in sauces, soup-stock, cream-of-vegetable soups, etc. It contains nutritive matter dissolved from the vegetables.

4. For vegetables cooked whole or in large pieces, keep the water boiling that they may cook in the shortest possible time. Peas, beans, and any vegetables served in the cooking water are better simmered.

5. Green vegetables keep their color better if cooked uncovered. The reason for this is not known. Cook onions and cabbage uncovered; their odor is less noticeable when allowed to pass off continually than when escaping occasionally in bursts of steam.

6. The time required to cook any given vegetable depends upon its size, age, and freshness. Old beets may be so woody that they cannot be cooked tender. Dried or wilted vegetables cook more quickly if first soaked in cold water.

Seasoning vegetables. — Use two teaspoonfuls of salt to one quart of water in which large vegetables are to be boiled. To one pint of small, cooked vegetables, — beans, peas, onions, etc., — or to one pint of mashed or cubed turnips, potatoes, etc., use two tablespoonfuls of butter, one-half teaspoonful of salt, and one-eighth teaspoonful of white pepper.

Scalloped vegetables. — Many kinds of cooked vegetables may be scalloped; potatoes, onions, cabbage, and cauliflower are excellent so prepared.

For scalloping, cut potatoes into cubes, quarter or tear apart onions, separate the flowerets of cauliflower. Cabbage leaves, if not separated before cooking, must be pulled apart. Season the vegetable as directed above, put it into a baking-dish, pour over it thin White Sauce, allowing one cupful and a half of sauce to each pint of vegetables. Cover with buttered crumbs, and bake till the crumbs are brown.

INGREDIENTS FOR THIN WHITE SAUCE

Butter, 2 tb.

Milk, 1 c.

Flour, $1\frac{1}{2}$ tb.

Salt, $\frac{2}{3}$ t., or more.

Pepper, $\frac{1}{8}$ t.

Vegetables served raw. — *Celery.* Use only the inner stalks. Wash these, scraping them if not perfectly white, cut off all but a little of the tops, and soak in cold water till crisp. Serve them laid in a glass dish. *Cucumbers.* The seeds and coarse fibres of cucumbers make them one of the most indigestible of foods. Soaking in salt water wilts them, increasing their indigestibility. Pare them, cut thick slices from the ends to remove medicinal salts, and slice *thin.* *Radishes.* Wash and cut off the tops, make cuts across the tops of the roots through the skin, and turn this back in points. *Tomatoes.* Peel and slice in half-inch slices. (See Preparation of Tomatoes in table, p. 251.) Serve very cold.

TABLE OF INFORMATION ABOUT VEGETABLES

VEGETABLE	SELECTION; CARE AFTER BUYING	PREPARATION FOR COOKING	METHOD OF COOKING	TIME	SERVING	REMARKS
ASPARAGUS.	Stalks should be green; the ends should show that they have been recently cut. Keep standing in cold water.	Cut stalks off as far down as they are brittle. Untie the bunches, wash stalks, and retie them in bunches right to serve to one person. Tie these into one bunch again, and stand it in cold water till put on to cook.	Stand the asparagus in a deep kettle, and pour in boiling water to cover all but the tips. Let it boil tightly covered till the stalks are tender. The steam cooks the heads. Salt when nearly tender. (See Plate XIII.)	About 45 min.	Drain, and butter. Serve on strips of toast moistened with the cooking water and buttered.	Keep the rest of the water to use in making Cream-of-Asparagus Soup.
BEANS (Lima).	Buy green, juicy pods with small veined beans.	Wash and shell.	Cook uncovered in barely enough boiling water to cover them. Let this boil down toward the last. Salt when nearly done.	1 to 1½ hr.	Serve without draining; season with butter and pepper.	
CORN.	Silk should be brown. Tear husk open, and see that ear is filled with well-developed kernels. Try a kernel with your nail, — sweet milky juice should flow. Remove outer husks as soon as it comes from market. Cook as soon as possible. Corn is injured by keeping.	Take off outer husks; remove silk; fold inner husks back over the ear.	Cook in boiling water until, when a kernel is pressed, no juice flows.	5 to 15 min.	Remove husks and serve ears whole, in a napkin. Or shave off the top of the kernels, scrape out the pulp with the back of a knife, season with butter, pepper, and salt, and reheat with a little milk.	Cooking in salted water wrinkles and hardens corn.

<p>STRING BEANS.</p>	<p>Break a pod; it should be brittle. Strings should be delicate, and beans very small.</p>	<p>Wash, pull off the strings, and snap or cut the pods into inch pieces.</p>	<p>Cook in barely enough boiling water to cover them, letting this boil down when beans are nearly cooked. Salt when nearly done.</p>	<p>For young beans, 1 hr. For old ones, 2 to 3 hr.</p>	<p>Serve without draining; season with butter and pepper.</p>	
<p>BEETS.</p>	<p>Choose those with dirty roots and fresh, green leaves. If roots are clean, beets have probably wilted and been freshened by soaking.</p>	<p>Wash, taking care not to break the skin. Cut tops off about two inches above the root. If cut <i>short</i>, the beet will lose color and sweetness.</p>	<p>Cook in boiling water till tender. Salt half an hour before taking from fire.</p>	<p>For young beets, about 1 hr. For old beets, 4 or 5 hr.</p>	<p>Rub off the skins with a dry cloth. Slice large beets, small quarter ones. Season with butter, pepper, and salt.</p>	<p>Tops of summer beets may be cooked with roots, and served separately as "greens." Avoid trying beets till you think they are really done.</p>
<p>CABBAGE.</p>	<p>Choose a hard, heavy one, with crisp white leaves, and stalk cut close to the head. Keep in cool, dark place.</p>	<p>Remove outer leaves. Cut out stalk, and separate inner leaves, removing any insects found.</p>	<p>Cook inner leaves, uncovered, in boiling salted water till tender, but not <i>sodden</i>.</p>	<p>About 20 min.</p>	<p>Drain, and season with butter, salt, and pepper, or mix with white sauce.</p>	

TABLE OF INFORMATION ABOUT VEGETABLES. — *Concluded*

VEGETABLE	SELECTION; CARE AFTER BUYING	PREPARATION FOR COOKING	METHOD OF COOKING	TIME	SERVING	REMARKS
CARROTS. Young (summer). Old (winter).	See that leaves are green and fresh. Choose the smaller ones.	Wash and scrape; drop into cold water. Wash and scrape; cut into half-inch cubes.	Cook in boiling water. Cook in a small quantity of boiling water.	30 min. to 1 hr. 20 to 30 min.	Serve in thin white sauce, or with green peas. Serve in thin white sauce.	Peas and carrot cubes are a good garnish for meat.
CELERY.	Buy only when white, crisp, and fresh.	Cut off root; wash and scrape outer stalks; cut them into one-inch pieces.	Simmer them till tender in water to cover them.	5 to 15 min.	Drain, and serve covered, with white sauce.	Save root for soup stock, water for Cream-of-Celery Soup. Serve inner stalks raw.
PEAS.	See that pods are green and brittle, peas green. Young peas are small. Cook as soon as possible. Peas are injured by keeping.	Wash the pods before shelling.	Cook in barely enough water to cover, adding salt 15 minutes before taking from fire. Let water boil down when peas are nearly cooked.	30 to 40 min.	Serve without draining, season with butter and pepper.	Should the peas lack sweetness, add $\frac{1}{2}$ t. of sugar to each half-peck of peas while cooling.

SPINACH.	Choose that with leaves fresh and <i>dirty</i> . If clean, they have wilted and been soaked to revive them.	Cut off roots, stems, and poor leaves and wash by lifting from one pan of cold water to another, till water is free from sand.	Cook in its own juices, heating it gradually till these are drawn out.	About 15 min.	Season with butter, salt, and pepper, and reheat.	Rather old spinach may be better cooked in water and drained.
SQUASH. Crockneck or Summer. Hubbard or Winter.	Good ones are light yellow, the shell tender enough to be broken with the finger-nail. Choose sound ones with no soft spots. If you buy a quantity, keep them spread out in a dry place.	Wash, cut into pieces, and pare. Break into pieces with hatchet; take out shreds and seeds.	Cook in a steamer or a strainer placed over boiling water. Steam like summer squash.	About 30 min. About 40 min.	Mash, and season with butter, salt, and pepper. Scoop out inner part. Rub through a colander; season with butter, pepper, and salt.	If very watery, press out the part of the juice by squeezing the pieces of squash between the colander and a plate.
TOMATOES.	Best ones are firm, smooth, and evenly red, with no decayed, bruised, or green spots.	Let them stand covered with boiling water for one minute to loosen the skins; peel and cut into pieces.	Simmer them.	About 20 min.	Add for each pint of tomatoes 1 tb. butter, $\frac{1}{2}$ t. salt, f.g. of pepper, and 1 or 2 t. of sugar. To thicken, stir in 2 tb. of pounded and sifted cracker crumbs; or omit crumbs and serve on buttered toast.	Pink tomatoes are usually less acid than red ones.

SUGGESTIONS ABOUT COOKING AND SERVING VEGETABLES

1. Strong-flavored vegetables may have to be cooked in a generous supply of water to make them palatable. As this wastes them, it is better to buy mild-flavored ones. The less well-supplied the table is with vegetables, the more important is it that they should be cooked so as to save all the nutrients.

2. Avoid piercing vegetables to see if they are cooked. A knitting-needle breaks them less than a fork.

3. As one object in using vegetables is to give variety to our diet, take pains to vary the vegetables served from day to day; if you can get but few kinds, vary the ways of cooking these.

4. Take particular pains to make winter vegetables attractive to sight and taste.

5. It is a mistake to serve peas or other delicately flavored vegetables with white sauce. Butter is best, except for onions, turnips, cabbage, and cauliflower. Cream is delicious with many vegetables, but is too expensive for most people. Some people cook a piece of bacon with peas or string beans. But this method destroys the natural flavor of the vegetable.

6. Tomato, or a vegetable dressed with acid — pickled beets or cole-slaw, — is appetizing with fish. With delicately flavored meat, such as chicken or veal, do not serve a strong vegetable like cabbage. Custom prescribes peas with lamb, apple sauce with pork and goose, cranberry sauce with turkey.

SECTION 3. CREAM-OF-VEGETABLE SOUPS (PURÉES)

A cream-of-vegetable soup is a white sauce to which has been added the juice or pulp of some vegetable. A soup made quite thick with pulp is sometimes called a purée. Vegetables too old or too tough to be served whole should be made into soup or purée, as straining removes the hull and coarse fibre, leaving the digestible part of the vegetable. Flour or cornstarch is added to these soups to keep the vegetable from settling. This flour or cornstarch and the butter usually mixed with it are called "binding material," because they bind together the solid and liquid parts of the soup.

RECIPE FOR GREEN PEA SOUP

¹ Green peas, 1 pt.	Salt, 1 t.
One small onion.	Pepper, $\frac{1}{8}$ t.
Boiling water, 1 qt.	Sugar, $\frac{1}{2}$ to 1 t. (more for old peas
Milk, 1 pt., or more.	than for young).
Butter, 2 tb.	Flour, 2 tb.

Peas too old to be served as a vegetable may be used for soup. Cook the onion with the peas in the water. Scald the milk. When the peas are very soft, remove the onion and mash the peas through a strainer, add to them the milk, and reheat. Rub the flour and butter together, stir into them a little of the soup, and turn this mixture back into the rest of the soup. Stir till smooth, add seasoning and sugar, and serve with croûtons.

To prepare croûtons, cut buttered slices of bread one-half inch thick into half-inch squares. Heat these on a pan in

¹ Or use 1 can of peas and 1 pint of water.

TABLE OF CREAM-OF-

NAME OF SOUP	VEGETABLES	LIQUID		BINDING OR THICKENING	
		Water	Milk	Butter	Flour
Cream of tomato.	Tomatoes, $\frac{1}{2}$ can.		1 qt.	2 tb.	3 tb.
Cream of asparagus.	Asparagus, 1 bunch.	1 qt. (Boil down to 1 pt.)	1 pt.	2 tb.	2 tb.
Cream of celery.	Celery, 3 roots, or 3 outside pieces of 3 stalks with leaves.	1 pt. hot, or enough to cover the celery.	1 qt.	2 tb.	2 tb.
Cream of turnip, carrot, etc.	Mashed vegetable, 1 to 2 c.	1 pt. of the water the vegetable was cooked in.	1 pt.	2 tb.	2 tb.
Potato.	3 large potatoes.		1 qt.	2 tb.	2 tb.
Split pea.	Dried split peas, 1 c.	3 pts. cold.	Enough to thin the soup properly.	2 tb.	2 tb.

VEGETABLE SOUPS

SEASONING	OTHER INGREDIENTS	SPECIAL DIRECTIONS FOR PREPARING THE SOUPS For General Directions, see pp. 256, 398.
Salt, 1 t. Pepper, $\frac{1}{8}$ t.	Soda, f.g.	Scald the milk, and thicken it with the flour and butter. Cook the tomatoes ten minutes, or till soft, add the soda, and strain. Stir the tomato slowly into the thickened milk, taking care that it does not cook after being mixed, and serve at once. (See Caution on p. 257.)
Salt, 1 t. Pepper, f.g.		Break off the heads, and cook them with the stalks in the water. Take out the heads as soon as they are tender, and either serve them on toast, or put them in the tureen before turning in the soup.
Salt, $1\frac{1}{2}$ t. Celery salt, $\frac{1}{8}$ t. Pepper, $\frac{1}{8}$ t.		Wash the celery, cut it into short pieces, and simmer it in the water till soft.
Salt and pepper, according to quantity of seasoning already added to the vegetable.		If a "left-over" mashed vegetable is used, heat the milk and water together, and pour them on to it. Strain and bind as usual.
Salt, 1 t. Pepper, $\frac{1}{8}$ t.	Parsley, 2 t. Bit of bay-leaf. Onion, 1 slice. Celery-root (if on hand).	Boil the potatoes, and mash them through a strainer into a saucepan. Cook the onion in the milk. When the latter reaches the scalding-point, take out the onion, and stir the milk into the potato. Bind with the flour and butter; season; strain into a tureen, and sprinkle with parsley.
Salt, 1 t. Pepper, $\frac{1}{8}$ t.	Ham-bone, slice of onion, or both, may be cooked with the peas.	Soak the peas overnight. In the morning drain them and simmer them in the water two hours or more, adding more water as the first boils away. When very soft rub peas and water through a strainer.

the oven, stirring occasionally, till they are crisp and golden-brown. Pass them with soup. They may be kept and reheated.

RECIPE FOR TOMATO SOUP WITHOUT STOCK

NOTE. — This soup, although it contains no milk nor cream, is given here because in other respects it is made like cream-of-vegetable soups.

Tomatoes, 1 can, or	Cloves, 4.
Fresh-cooked tomatoes, 1 qt.	Cornstarch, 3 tb.
Hot water, 1 pt.	Butter, $\frac{1}{4}$ c.
Onion, 1 slice.	Sugar, 1 tb.
Celery salt, 1 t., or	Pepper, f.g.
Salt, 1 t., and a sprig of celery cooked in the soup.	

Cook water, tomatoes, onions, and cloves together for twenty minutes; strain and add the butter; stir in the cornstarch wet to a smooth paste with cold water; boil the soup till clear; and season.

Cornstarch is used in this recipe because it gives a clearer soup than flour does. Why is it mixed with water instead of with butter? Which lumps most easily, pure starch or flour? Why? Why is more thickening required for tomato than for pea soup?

General proportions of ingredients for cream-of-vegetable soups. — To one quart of liquid (water, milk, stock) use one to two cupfuls of *thick* vegetable pulp, two tablespoonfuls of butter, one to three tablespoonfuls of flour, one teaspoonful of salt, and from a few grains to one-eighth of a teaspoonful of pepper.

General directions for making cream-of-vegetable soups. — *First method.* Cook the vegetable in water till very soft.

Press the pulp through a sieve, vegetable press, or strainer, using the cooking water to help wash the pulp through. Heat milk and pulp together, stir into them the binding material (cornstarch mixed with water, or flour mixed with butter), boil till smooth, and season. If too thick, add more milk. The coarser the vegetable, the coarser should be the strainer used. Onions, herbs, and whole spices may be cooked in the water or milk used in the soup; other seasonings are added at the last. *Second method.* Use equal parts of thin white sauce and of vegetable water or pulp and water. Mix together, boil till smooth, and season. **To make the soup richer**, part cream may be used instead of all milk, or white stock instead of water.

Two or more left-over vegetables may be combined in one soup.

Study the table on pp. 254 and 255, noting in what respects the soups are alike, in what different. Think out, if you can, the reasons for variations in quantity of water used, time of cooking, etc.

Caution. — Cream-of-tomato soup (see table, p. 254) must be made with great care to prevent the acid in the tomatoes from curdling the milk. Pour the tomato slowly into the milk; if the milk be poured into the tomato, it will curdle. Take care not to combine milk and tomato till just before the soup is served, as milk heated with acid is almost sure to curdle. Adding a bit of soda helps to neutralize the acid. Draw the saucepan away from the heat before adding the soda; otherwise the tomato may foam over. Explain this. What gas is formed? (P. 108.)

BEAN PURÉE

Beans, 1 qt.	Baking-soda, $\frac{1}{4}$ t.
Onion, 1 small one.	Butter, 2 tb.
Carrot, 2 slices.	Milk or cream.
A bit of bay-leaf.	Salt, $\frac{3}{4}$ t.
Pepper, a f.g.	

Wash the beans, and soak in cold water overnight. In the morning drain, cover them with cold water, and when this boils, drain them again. Add soda, onion, bay-leaf, and carrot. Boil gently until the beans are soft; then press them through a colander; add butter, salt, pepper, and milk or cream enough to thin the purée to your taste. Serve as a vegetable.

SECTION 4. SALADS

The salad, or "salet," of olden times was always a dish of green herbs dressed with vinegar and other condiments.

Lettuce is still eaten by some people with vinegar and sugar.

But the salad of to-day, while it always includes some green vegetable, either cooked or raw, may include almost any other food. Chicken, lobster, hard-boiled eggs, many kinds of vegetables, fruits, nuts, and cheese, are among the materials most often served in salad form. Lettuce is served alone or as a bed for these other ingredients. The dressing usually contains oil, butter, or cream. Romaine, chicory, endive, cress, and other edible leaves, are used as lettuce is. Olive-oil, peanut-oil, or the best grade of cotton-seed oil may be used in salad dressings. (See Vegetable fats and oils, p. 213.)



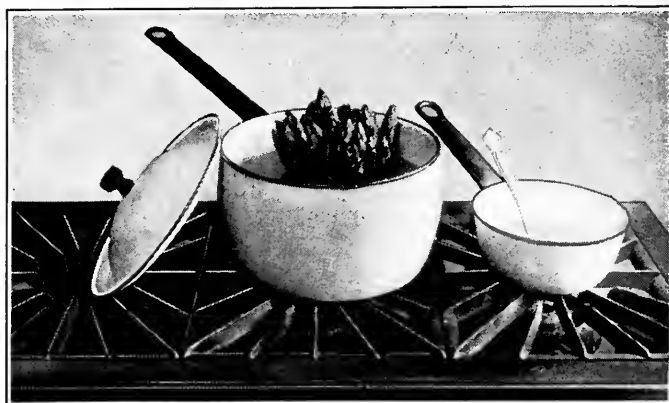

ASPARAGUS COOKING.



SALADS.

Stuffed tomato.

Pepper.

Sliced cucumber.



MACÉDOINE SALAD.

SALAD-MAKING

Four things essential in salad-making. — A salad must be *cold*, the greens in it *crisp*, the ingredients in the dressing *carefully proportioned and blended* so that it shall be neither oily nor acid, and the whole *well-mixed*. With these conditions fulfilled, a handful of lettuce leaves dressed with salt, pepper, oil, and vinegar is in its way a perfect dish. Because of the judgment and deftness required to produce this perfection, it is often desirable to dress the salad at the table rather than to have it brought to the table dressed.

Preparing the ingredients. — Lettuce is used as a bed for any salad. As soon as it comes into the house, sprinkle it, and put it in the ice-box, in a covered pail, if you can. To prepare it for use, cut off the stem, separate the leaves, discard the outside ones, and let the others lie for at least fifteen minutes in the coldest water you can provide. Wash them clean, taking care not to break them; look sharply to see that no insects cling to them; shake lightly or swing them in a wire basket or a salad-net¹ to dry them partially; and wipe them carefully with a soft cloth. If left wet, the dressing runs off them. Freshen and dry other salad leaves in the same way. *Other vegetables.* — (For tomatoes and cucumbers, see p. 247.) Remove the strings from string beans, and cook them without breaking or cutting. Keep parsley in a glass of water, with only the roots wet. Cut cooked vegetables except potatoes into half-

¹ Bags made of coarse netting are sold for this purpose.

inch cubes, or small irregular bits. Put remnants of cooked vegetables into a colander and pour hot water over them to rinse off any butter.

Arranging the salad. — If only lettuce is to be served, put it in a pretty bowl, either glass, or of some color that looks well with the green of the leaves. Arrange these to form a frill above the edge of the dish, and let the centre be a nest of cool shadowy green. The arranging of salads gives a girl a chance to display artistic skill no less than does the embroidering of a doily, or the making of a sketch. How satisfactory to be able to combine those few spoonfuls of peas, beets, potatoes, and what not, left from two or three dinners into a pyramid of pretty colors, wreathed with green and blossoming with radish “rose-buds”! (Macédoine Salad.) Or, starting with fresh materials, what pleasure may be found in bringing out the beauty of glowing tomatoes nestled in palest green, and crowned with golden Mayonnaise! (Stuffed Tomato Salad.) Nor do thrift and taste and judgment alone come into play in salad-making; use your originality and invention, and you can produce many a salad not described in cook-books, but delightful to eye and taste.

To dress lettuce at the table. — Mix oil and seasonings in the salad spoon, pour them over the lettuce, and toss and turn this till every leaf is coated. Then add the vinegar, and toss again. To vary the flavor, have the salad bowl rubbed with a “clove of garlic,” or have a piece of bread rubbed with garlic at the bottom of the bowl.

Reasons why salads should be eaten more than they

are. — While the food value of a green salad is not large, the salts it supplies and its refreshing, appetizing qualities make it a most wholesome food. The oil or butter used in dressing it furnishes fat in a digestible form. The acid vinegar is believed to help digest the cellulose. Salads are prepared with little trouble and with no expense for fuel. Some vegetable suitable for salad can be obtained all the year round, even canned ones making, with fresh greens, an acceptable dish. If you cannot have salad every day, have it as often as you can. Some people now have salad instead of dessert, and if you cannot have both at the same dinner, it is well to substitute salad for pudding two or three times a week at least.

PLAIN FRENCH DRESSING

Salt, $\frac{1}{2}$ t.

Olive oil, 3 tb. or more.

Pepper, $\frac{1}{4}$ t.

Vinegar (malt, wine, or tarragon), 1 tb.

Onion juice (if desired), or rub the salad bowl with a clove of garlic.

Stir the seasonings into the oil, add the vinegar, and stir vigorously until the dressing thickens slightly. A larger quantity made in the same proportions may be passed in a bowl.

COOKED SALAD DRESSING (without oil)

Mustard, $\frac{1}{2}$ t.

Sugar, 1 t.

Salt, $\frac{1}{2}$ t.

Yolk of 1 egg.

Cayenne, f.g.

Milk, $\frac{3}{4}$ c.

Flour, 1 tb.

Butter, melted, 2 t.

Hot vinegar, $\frac{1}{4}$ c.

Mix the dry ingredients in a saucepan, stir into them the yolk of egg, butter, and milk. Stir the mixture over hot water until it begins to thicken, then stir in the vinegar, a few drops at a time. When as thick as thick cream, strain and cool.

MAYONNAISE DRESSING

Yolk of 1 egg.	Cayenne pepper, f.g., or paprika, $\frac{1}{4}$ t.	Mustard, if liked,
Olive oil, 1 c.	$\frac{1}{2}$ t.	Lemon juice or strong malt or tarragon
Salt, $\frac{1}{2}$ t.	vinegar, about 2 tb.	

Mix in a bowl or soup-plate with a silver fork. To insure success, have bowl, oil, and egg very cold; and add oil very slowly. In summer set the bowl in a pan of cracked ice while mixing the dressing.

Break and separate the egg, taking care that no white remains with the yolk. Beat the yolk thoroughly, and stir into it the seasonings mixed and some of the vinegar or lemon-juice. Add the oil, a teaspoonful at a time at first, beating hard. As it thickens, add more rapidly, but never add more until that in the bowl has become thoroughly mixed with the egg. When too stiff to beat easily, add a little vinegar or lemon juice, and continue adding oil and vinegar alternately, until all is in. The dressing should hold its shape. More oil and seasonings can be added to one yolk to make a larger quantity of dressing.

If the dressing should separate, beat another yolk, and beat the dressing slowly into it, as you would oil.

To keep mayonnaise, put it into a covered jar on the ice-box.

French dressing may be served with any green salad.

Either mayonnaise or cooked salad dressing is appropriate with almost all vegetables. Cooked dressing is usually used with cabbage; mayonnaise usually with meat or fish.

NOTE TO TEACHER. — White of egg may be used instead of yolk for mayonnaise. Half the pupils may use whites and half may use yolks, and all the dressing be mixed at the end of the lesson.

MIXED VEGETABLE OR MACÉDOINE SALAD

Cold cooked peas, carrots, beets, string beans, almost any cold vegetables, may be combined in this salad.

Cut beets and carrots in half-inch cubes, string beans and celery in short lengths, mix each vegetable separately with French dressing, and arrange them in sections, forming a circular mound. Let vegetables of contrasting colors come next each other. Garnish with radishes, celery tips, lettuce leaves, etc. (See plate XIII, facing page 259.)

POTATO SALAD

Hot boiled potatoes cut into $\frac{1}{2}$ -inch cubes, 3 c.

Salad oil, 9 tb.

Pepper, $\frac{1}{4}$ t.

Vinegar, 3 t.

Onion, chopped fine, $\frac{1}{4}$ c.

Salt, 1 tb.

Parsley, cut fine, 1 tb.

Mix these ingredients thoroughly, heap the salad on a dish, and garnish with radishes, sliced, or cut in rose form (p. 247), and sprigs of parsley.

STUFFED TOMATO SALAD

Medium-sized tomatoes, 8.

Mayonnaise dressing, 1 c.

Celery cut in small pieces,

Lettuce.

or

Salt.

Cucumber cut in cubes, 2 c.

Scald and peel the tomatoes ; slice off their tops. Scrape out the seeds and a little of the pulp, and fill the cavities heaping full with celery or cucumber mixed with Mayonnaise dressing. Make on a platter, or on separate plates, nests of tender lettuce leaves, and put a tomato in each nest.

COLE-SLAW

One-half of a small hard cabbage.
Cooked salad dressing, hot, 1 c.

Soak the cabbage in cold salt water for thirty minutes, shred it fine with a sharp knife or vegetable shredder, and mix the dressing with it. Serve cold.

BRIEF REFERENCE LIST

For further development of topics treated in this section see : —

SHERMAN : *Food products*. Ch. 9.

BIGELOW : *Applied biology*. Ch. 8.

SNYDER : *Human foods*. Ch. 3 and 6.

SNELL : *Household chemistry*. Ch. 38.

WARD : *Grocers' encyclopedia*.

U. S. DEPT. OF AGRICULTURE : *Farmers' bulletins*: 121. Beans, peas, and other legumes as food ; 256. Preparation of vegetables for the table ; 232. Okra, its culture and uses ; 298. Food value of corn and corn products ; 559. Use of corn, kaffir, and cow peas in the home. *Yearbook for 1911*, pp. 439-452, Green vegetables and their uses in the diet.

CHAPTER IX

SUGAR AND SWEETS

SECTION 1. SUGAR — CANDIES

A STUDY OF SUGAR

Review a study of starch, p. 68.

A. Examine granulated white sugar, and (if possible to obtain it) some solid glucose. In which are the particles most distinct? Taste each. Which is the sweeter? If solid glucose is not obtainable, use commercial glucose, "corn-syrup."

Experiments with glucose and with white sugar. — **B.** Stir sugar into a glass of cold water until no more will dissolve. Do the same with boiling hot water. Does sugar dissolve better in hot water or in cold?

C. Heat a little sugar slowly in a test-tube till it melts. What forms on the sides of the tube? What two elements must sugar contain? Pour out some of the liquid. Continue to heat the rest till it turns brown. Heat the rest till only a dry black substance is left. What do you think this is?

D. Repeat these experiments with glucose.

E. Put into a test-tube a little of the glucose solution in the glass. Add a few drops of Fehling's solution and boil. What happens? Try the same experiment with the sugar solution. If you had a can of syrup and you did not know whether it contained glucose, how could you find out?

In what ways are sugar and glucose alike? How do they differ? In what ways do both resemble starch? (See experiments in heating starch, p. 69.)

Sugars are carbohydrates. — Like starches, they are composed of carbon and of hydrogen and oxygen in the right

proportion to form water. Starches can be changed into sugars. (See p. 70.)

The different sugars. — When we use the word sugar, we usually mean the kind of sugar in most common use, that which is made from sugar-cane or from sugar-beets. But there are many sugars, just as there are many starches. Cane-sugar and beet-sugar, however, are not really two different sugars. They are chemically the same, and the name *cane-sugar* is applied to both. *Glucose* is also a sugar, but it has different properties from cane-sugar. It is less sweet and less soluble than cane-sugar, and it does not readily form crystals as cane-sugar does. With Fehling's solution glucose forms a red precipitate. Cane-sugar does not. Cane-sugar melts at 320° , forming a clear liquid. When cool this remains transparent and is called barley sugar. At a higher temperature the liquid becomes brown. Some of the water has been driven off, and a mixture of dark-colored substances called caramel is formed. Caramel is used for coloring and flavoring. When all the moisture is driven off, only carbon is left.

Glucose is known also as grape-sugar because it is abundant in grapes. When grapes are dried to make raisins, the grape-sugar appears on the surface in grains, as it does also on other dried fruits. It occurs in many fruits and some vegetables, usually with another sugar, called fruit-sugar, or fructose.

When cane-sugar is boiled with acid, some of it splits into grape-sugar and fruit-sugar.

Milk-sugar is prepared from milk for use in infant's food and in medicine. *Honey* consists chiefly of glucose and

fructose with flavoring matter from the flowers. It was used for sweetening before cane-sugar was known.

The chief sources of cane-sugar are the sugar-cane, sugar-beets, the sugar-maple, the sugar-palm, and sorghum. Americans and Europeans use mostly cane- and beet-sugar. Sugar-cane is a tropical grass, higher than corn. Sugar-beets are large and white. They grow in different climates, including places where it is too cold for sugar-cane.

The manufacture of sugar. — In cane-sugar factories the juice is squeezed out of the canes between rollers. In beet-sugar factories, the beets are sliced into strips and the juice dissolved out of them in tanks of warm water. After this the process is similar in all factories. The juice is purified, filtered, and boiled down¹ to a syrup. This syrup is boiled again till sugar crystals form. The sugar is separated from the uncrystallizable part of the syrup in a centrifugal drier, a wire basket which throws the syrup out as it revolves. This "raw sugar" varies in grade and color. Some of it, including brown sugars, is sold without refining. Most of it, including all beet-sugar, is refined. *Granulated sugar* has been refined, dried, and sifted. *Cube* or *domino sugar* has been refined, and either moulded and sawed or pressed into blocks. *Pulverized* and *confectioner's sugar* are made by grinding and sifting the fragments of block sugar. *Brown sugars* are less refined grades. Refined white sugar is said to be the purest manufactured food we have.

¹ All boiling is done in vacuum kettles and pans. These are air-tight vessels from which part of the air has been drawn out to lower the boiling-point and so avoid burning the syrup.

It is rarely adulterated. But it is blued, much as clothes are. Manufacturers declare it would not sell if left its natural creamy color. What do you think about this?

Molasses. — The uncrystallizable syrup separated from sugar forms molasses. “Porto Rico” molasses is darker than “New Orleans.” Modern methods of sugar-making do not produce the rich dark molasses of former days.

Experiment with molasses. — Test molasses with litmus paper. Is it acid or alkaline? If acid, put a little in a test-tube and add a pinch of baking-soda. Test again. What does the foaming of the molasses show? (P. 108.)

Old-fashioned molasses was distinctly acid, and soda could be used with it to make batters light. If molasses is only slightly acid, or if only a little molasses is called for by the recipe, some baking-powder must be used besides the soda. Canned molasses may not be acid at all.

Table syrup is also made from cane-juice.

Sugar and syrup made from starch. — Weak acid acts on starch as diastase (amylase) does, converting it into a mixture of sugars and gums, finally into glucose. In this way great quantities of syrup are made from starch and sold as “glucose” or “corn-syrup.” The process is stopped when the liquor is about half dextrose and half dextrin. It contains a small quantity of mineral matter, which gets in during manufacture. Neutralized and purified, it forms a clear syrup. As it is almost tasteless, it is usually flavored with cane-sugar. This “commercial glucose” is said to be essential to the making of some kinds of candy. As it is much cheaper than cane-sugar, manufacturers who use it

in canned fruits are required by law to so state on the label. Solid glucose (commercial dextrose) is used for manufacturing purposes only. It comes in angular pieces, light-brown in color and brittle.

Digestion of cane-sugar. — Sugar is digested in the small intestine, where it is split into glucose and fructose. In small quantities it is completely digestible, and is rapidly absorbed. When eaten in excess, some of it is likely to undergo acid fermentation instead of digestion.

Food value of sugar. — Sugar is equal to starch as a source of muscular energy. Ordinarily we could not substitute sugar wholly for starch, because sugar is too rapidly digested to be handled by the body as advantageously as starch is. But in cases where great energy must be exerted in a short time, increasing the amount of sugar in the diet gives working power and delays fatigue. It has been noticed that lumbermen and hard-working farmers consume quantities of cakes, preserves, and other sweet stuff. Athletes and soldiers on the march tire less quickly when allowed extra sugar. It is natural that children, who are so active, should crave sugar, and right for them to have a certain amount of it. One virtue of sugar is its flavor, which makes other foodstuffs more palatable. There is danger, however, of its being used to excess just because it tastes good. It is a mistake to use so much sugar, either in cooking or at the table, that the mildly pleasant flavors of other foods are lost. Lunching on sweets and habitually eating candy between meals overburdens the system. Home-made candy is safest, especially for children.

U. S. Department of Agriculture
Office of Experiment Stations
A. C. True: Director

Prepared by
C. F. LANGWORTHY
Expert in Charge of Nutrition Investigations

COMPOSITION OF FOOD MATERIALS.

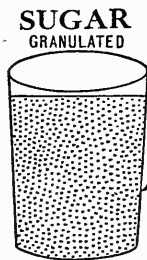

FUEL VALUE:
 1860 CALORIES PER POUND

MOLASSES

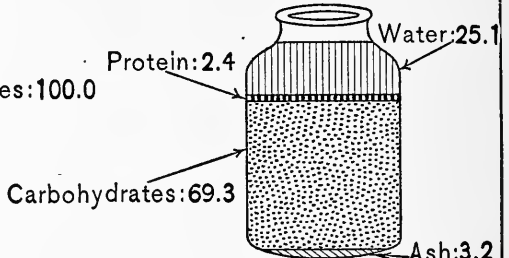

FUEL VALUE:
 1290 CALORIES PER POUND

STICK CANDY

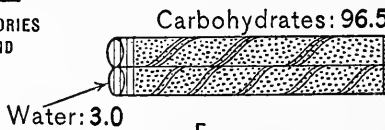

FUEL VALUE:
 1785 CALORIES PER POUND

MAPLE SUGAR

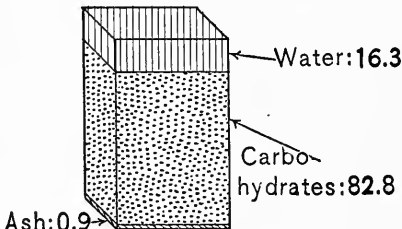

FUEL VALUE:
 1540 CALORIES PER POUND

HONEY

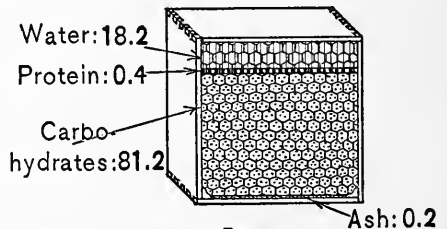

FUEL VALUE:
 1520 CALORIES PER POUND

CHART 12.

CANDY-MAKING

Syrup made by boiling sugar and water is used for most kinds of candy. The longer it boils, the thicker and hotter it becomes. At 220° F. a drop of syrup let fall from the spoon spins itself into a fine thread. At 238° F. a little syrup dropped into cold water can be rolled into a soft ball between the fingers, at 248° into a hard ball. At 310° it becomes brittle when dropped into cold water, and is said to be boiled to the crack. A sugar thermometer may be used to test the temperature.

Caramel. — Sugar heated dry melts. If heated to about 350°, it turns brown, showing that caramel has formed (p. 69). If we boil all the water out of syrup, and continue to heat it, it will caramelize.

MOLASSES CANDY

Molasses, 2 c.

Sugar, 1 c.

Butter, 3 tb.

Soda, $\frac{1}{2}$ t.

Vinegar, 1 tb.

Boil all together to the "hard ball" stage. Turn out on a buttered plate. This candy may be pulled just before it hardens. Butter the hands well before handling the candy.

BUTTER SCOTCH

Sugar, 1 c.

Water, 1 c.

Butter, 2 tb.

Molasses, 1 tb.

Vinegar, 2 tb.

Salt, f.g.

Boil all together to the crack. Do not stir more than just enough to keep it from burning. Drop from a spoon on buttered or waxed paper.

PEANUT BRITTLE

Sugar, 1 c.

Peanuts (shelled and pounded), 1 c.

A pinch of soda.

Melt the sugar to caramel. (A cast-iron pan is best for this purpose.) Stir in the peanuts very quickly, and pour into pans (not buttered). Tilt the pans to spread the candy. While it is cooling, mark it into squares with the back of a steel knife.

CHOCOLATE FUDGE

Granulated sugar, 3 c.

Butter, 3 tb.

Unsweetened chocolate, 2 oz. or

Milk, 1½ c.

Cocoa, ½ c.

Salt, f.g.

Vanilla extract, 1 t.

Boil all the ingredients except the vanilla to a soft ball. Let cool. Add vanilla. Beat until creamy. Pour upon a buttered dish. When partly firm, mark into squares.

FONDANT

Sugar, 2½ lb.

Hot water, 1½ c.

Cream of tartar, ¼ t.

Stir the ingredients together in a smooth saucepan. Let them come gradually to the boiling-point, keeping the pan covered. Boil to the soft-ball stage, or until the temperature is 238° F. This usually takes about 30 minutes.¹ Have ready an oiled marble slab or large platter. When the soft-ball stage is reached, pour the fondant slowly upon it.

¹ If cooked uncovered, the syrup requires only about 20 minutes. But granules form on the pan, which must be wiped off with a cloth wet in cold water. Cooking covered is easier for the inexperienced. When fondant is made in a moist atmosphere, it is likely to be grainy. It should be smooth.

Let it cool until it will keep the impression of the fingers. Work it with a wooden spatula or spoon until it is creamy. Then knead it with the hands until perfectly smooth. Put it into an oiled bowl and cover it with oiled paper to keep the air out. Let it stand 24 hours before using it.

Fondant may be colored and flavored and combined with nuts, fruit, cocoanut, chocolate, etc. in a variety of ways. For bonbons, make centres of small balls of fondant mixed with any of these other ingredients. Let them stand over night. Melt some fondant in a pan over hot water. Dip the balls in it, dropping in one at a time, and removing to oiled paper with a two-tined fork or a bonbon dipper.

NOTE. — Cream of tartar is used to prevent the fondant from crystallizing. Being acid, it helps to turn some of the cane-sugar into a mixture of grape-sugar and fruit-sugar, which does not readily crystallize.

BRIEF REFERENCE LIST

For further development of topics treated in this section see: —

SHERMAN: *Food products*. Ch. 11, Sugars, syrups, and confectionery.

SURFACE: *The story of sugar*. (Chiefly historical and commercial, ch. 12.

Candy, a national luxury.)

THORPE: *Dictionary of applied chemistry*. V. 4, p. 221.

WARD: *Grocers' encyclopedia*.

FOWLER: *Bacterial and enzym chemistry*. P. 83, Chemistry of the sugars.

WILEY: *Foods and their adulteration*. (Pt. 9, Sugar. Other places for adulteration and poor material in bakery-stuff.)

U. S. DEPT. OF AGRICULTURE: *Farmers' bulletins*: 535. Sugar as food; 52. The sugar beet; 516. Production of maple syrup and sugar; 503. Comb honey. Also *Bureau of Chemistry*: Bulletin 134. Maple sap syrup.

SECTION 2. CAKES AND DESSERTS

Compare the recipes for Egg Muffins (p. 113), Cottage Pudding, and Standard Cake (p. 277). Cake, you see, is only bread, with more shortening, sweetening, and eggs, in proportion to the flour. Cottage Pudding may be considered either a sweet muffin mixture, or a very plain cake.

Two classes of cakes: butter and sponge cakes. — All cakes belong to one of two classes, *butter cakes* and cakes without butter, or *sponge cakes*. Several kinds of cake can easily be made from one recipe, by varying the flavorings, spices, and fruits, by baking the same mixture in pans of different shapes, by frosting the cake or leaving it plain.

General rules for the proportions of ingredients in cakes. — In general, a cake should contain not more than one-third to one-half as much butter as sugar, and about half as much liquid as flour. Remember that butter, or other shortening, counts as liquid, since it melts in the oven. Sour milk and molasses do not thin a mixture as much as sweet milk or water. A cake with fruit should be a little stiffer than one without.

Every one who cooks should understand the principles of mixing and raising batters sufficiently to know when she reads a new recipe whether or not it will turn out well, and whether it is extravagant or reasonable.

How much soda is required for one pint of sour milk? (P. 109.) How much baking-powder for one cup of flour? (P. 111.) The more eggs there are in a cake, the less baking-powder is needed.

Account for the absence of baking-powder in Spice Cake and Gingerbread. Why is there no sugar in Gingerbread?

Why does Sponge Cake require no baking-powder? Notice some of the other ways in which recipes differ, and account for these in as many cases as you can. (See suggestions about using fat in cooking, p. 225.)

DIRECTIONS FOR MIXING CAKE

NOTE. — Read "Hints on How to Work," p. 52, "Batters and Doughs," p. 111, and "Helpful Hints about Mixing and Baking Quick Breads," p. 112. What is said about quick breads applies equally to cakes. See Breaking and separating eggs, p. 90, and Beating eggs, p. 90.

How to mix butter cakes.—Sift together all the dry ingredients except the sugar. (If fruit is to be used, save a little of the flour to mix with it.) Cream the butter and sugar. This means, first mash and beat the butter until it is soft and light-colored, and then beat in the sugar by degrees. When thoroughly creamed, the mixture is smooth and almost white. Separate the eggs, beat the yolks well, and then beat them into the butter and sugar. Add a little of the milk, then part of the flour (with the other dry ingredients sifted with it), a little more milk, and so on till all the flour and milk are stirred in, taking care to keep the mixture always of about the same degree of stiffness. Fold in the whites beaten very stiff. Add the flavoring and beat the mixture well. If fruit or nuts are to be added, fold them in last.

The eggs may be beaten whole and added to the butter and sugar, but separating them improves the texture of the cake. The process of mixing may be shortened by using a cake-mixer.

Compare these directions with those for mixing Egg Muffins. (P. 113.) What difference do you observe? For Cottage Pudding the butter is melted. Note the proportion of butter to sugar, and think why this is done.

How to mix Sponge Cake. — Beat the yolks till thick and lemon colored. Beat the sugar into them, add the flavoring (and other liquid, if the recipe calls for any). Beat the whites till stiff and dry; slip them into the mixing-bowl; sift the flour over them; and fold all together. It is best to use only a wire egg-beater in mixing sponge cake.

Fruit must be well floured and added last, or it will sink to the bottom of the loaf. To **stone raisins**, cover them with boiling water. When they become soft, squeeze out the seeds. Cut citron in thin strips. Nuts may be chopped or cut fine with a knife. (For the preparation of currants, see p. 136.)

Directions for baking. — The baking is a most important part of cake-making. No matter how skilfully cake is mixed, it will be spoiled if not properly baked.

Greasing cake pans. — Grease cake pans well with melted butter or butterine. (P. 105.) Pans for loaf-cake may be lined with white paper, and the paper greased.

The oven. — The oven should be less hot for cake than for bread. It is right for butter cakes baked in loaves, if it turns a piece of writing paper light brown in five minutes. For small cakes it should be hotter. Bake sponge cake in a moderate oven for forty to fifty minutes. Butter cake in a loaf requires about one hour; small cakes and layer cakes, about twenty minutes. When cake is done, it shrinks from

the pan and a broom straw run into it comes out clean. Let it stand three minutes. It will then slip out of the pan readily. Place it on a wire cake-rest or a clean towel to cool.

COTTAGE PUDDING

Butter, 2 tb.	Milk, $\frac{3}{4}$ c.
Sugar, $\frac{1}{2}$ c.	Baking-powder, 3 t.
Egg, 1.	Flour, $1\frac{1}{2}$ c.
	Salt, $\frac{1}{4}$ t.

Sift flour, baking-powder, and salt together. Beat the egg well, and beat the sugar into it. Stir in the milk and the flour mixture alternately (first a little of one, then a little of the other, till all is added). Melt the butter, and stir it in last. Bake in a buttered cake-pan about 25 minutes. Serve with Lemon Sauce (p. 282) or other liquid sauce.

STANDARD CAKE

Butter, $\frac{1}{4}$ c.	Milk, $\frac{1}{2}$ c.
Sugar, $\frac{3}{4}$ c.	Baking-powder, $2\frac{1}{2}$ t.
Eggs, 2.	Flour, $1\frac{1}{2}$ c.
	Vanilla, $\frac{1}{2}$ t.

Follow directions for making butter cakes. This cake may be made with one egg and 3 t. of baking-powder.

To vary this cake, add any one of the following :

1. $\frac{1}{2}$ c. chopped raisins.
2. $\frac{1}{2}$ c. currants.
3. $\frac{1}{2}$ c. sliced citron.
4. $\frac{1}{2}$ c. chopped nuts.
5. 4 tb. cocoa or 2 oz. chocolate, melted.

Or instead of vanilla use one of these :

6. 1 t. lemon extract.
7. $\frac{1}{2}$ t. almond extract.

Think up other variations, and try them.

SPICE CAKE

Butter, $\frac{1}{4}$ c.	Flour, 2 c.
Brown sugar, 1 c.	Chopped raisins, $\frac{3}{4}$ c.
Sour milk, 1 c.	Cinnamon, 1 t.
Baking-soda, 1 t.	Cloves, 1 t.
	Nutmeg, 1 t.

Cream butter and sugar, stir in milk; next dry ingredients; lastly, fruit.

GINGERBREAD

Butter, 2 tb.	Sour milk, $\frac{1}{2}$ c.
Molasses, $\frac{3}{4}$ c.	Baking-soda, 1 t.
Egg, 1.	Flour, 2 c.
	Ginger, 1 tb.

Sift the flour, soda, and ginger together. Heat the molasses, and pour it upon the butter. Stir well. Add the beaten egg, and sour milk, and dry ingredients. Bake 25 minutes in a moderate oven.

OLD-FASHIONED SPONGE CAKE

NOTE.—In the days when eggs were cheap, it was customary to use enough eggs in sponge cake to make it light without the addition of baking-powder. This cannot always be afforded now.

Eggs, 5.	Flour, $1\frac{1}{4}$ c.
Sugar, gran. or powd., $1\frac{1}{4}$ c.	Salt, $\frac{1}{4}$ t.
Juice and grated rind of half a large lemon.	

See directions for mixing sponge cake on p. 276. Bake one hour in a slow oven.

BAKING-POWDER SPONGE CAKE

Eggs, 3.	Flour, $1\frac{1}{2}$ c.
Sugar, 1 c.	Baking-powder, 2 t.
Hot water, $\frac{1}{3}$ c.	Vanilla, 1 t. <i>or</i>
	Lemon extract, $\frac{1}{2}$ t.
	Salt, $\frac{1}{4}$ t.

Mix according to directions for mixing sponge cake, adding the hot water when part of the sugar has been beaten into the yolks. Bake forty-five minutes to one hour in a loaf, thirty-five minutes in small cakes.

SUGAR COOKIES

Butter, $\frac{1}{2}$ c.	Milk, 2 tb.
Sugar, 1 c.	Baking-powder, 2 t.
Egg, 1.	Flour, about 3 c.
	Nutmeg.

Mix according to directions for butter cake, using enough flour to make a dough stiff enough to roll out. Turn it on to a floured board. Roll out, part at a time, one-eighth of an inch thick. Cut out with a floured cookie cutter. Keep board and rolling-pin well floured. Sprinkle cookies with grated nutmeg. Bake 15 minutes on baking sheets or shallow pans.

WHOLE WHEAT GINGER SNAPS

Butter, $\frac{1}{2}$ c.	Milk, $\frac{1}{4}$ c.
Sugar, 1 c.	Baking-powder, 1 t.
Molasses, 2 tb.	Baking-soda, $\frac{1}{4}$ t.
Egg, 1.	Flour, about 3 c.
	Ginger, 1 tb.

Cream the butter and sugar. Stir in the molasses, beaten egg, and milk, and last, the other materials sifted to-

gether. Roll as thin as possible. Cut out like sugar cookies, and bake in a moderate oven.

The points of good cake. — A good butter cake is smooth on top and an even golden-brown all over. It should round up slightly in the middle, but not sink from the edges and rise sharply with a crack on the top. Such a cake either contains too much flour or has baked too fast. The inside of the loaf should be slightly moist, but not sticky, and of a fine, even grain, with no heavy streaks. Coarse-grained cake is usually caused by lack of beating or by too slow an oven. Sponge cake should rise in the oven, and settle to a *level*, not lower, after being taken out. The top crust should be slightly sugary, the texture looser than that of butter cake, but tender and velvety. Too much flour makes sponge cake tough.

Chocolate Layer Cake. — Bake Standard Cake in three jelly-cake tins, and spread chocolate frosting on top and between the layers.

POINTS TO BE REMEMBERED IN CAKE-MAKING

1. Pastry flour makes the tenderest cake, but bread flour gives satisfactory results. If you substitute bread flour for pastry flour in a recipe calling for the latter, use but seven-eighths of the measure given.

2. If you cannot get fine sugar, sift what you have. Sponge cake is better for having both flour and sugar sifted separately several times.

3. See that the fire is so arranged that the oven will be ready when the cake is mixed.

4. If very little butter is used, melt it and add it to the sugar, or to the sugar and eggs. In cold weather warm the bowl slightly with hot water before creaming butter. A teaspoonful or two of milk may be added to the butter and sugar, if they are very slow to cream.

5. Cake containing molasses burns easily. Bake such cake and any thick loaves requiring long baking in tins lined with greased paper.

6. If cake browns within fifteen minutes after it is put into the oven, the heat is too great. Reduce it, or make a tent of brown paper over the pan, shaped like this . A pan of water put into the oven will reduce heat.

QUICK FROSTING (*Boston School Kitchen Text-book*)

Powdered sugar, 1 c.	Boiling water, 1 tb.
Lemon juice, 1 tb.	

Mix these ingredients, and add more boiling water, a few drops at a time, till the sugar settles when you cease stirring. Spread on cake while the latter is hot.

SOFT FROSTING

Granulated sugar, $\frac{1}{2}$ c.	Water, $\frac{1}{4}$ c.
White of 1 egg.	Lemon juice, $1\frac{1}{2}$ t.
Lemon extract, $\frac{1}{2}$ t.	

- Stir the sugar and water in a saucepan till the syrup boils, then boil it *without stirring* till it threads. (P. 271.) A little before it reaches this point, beat the white-of-egg stiff. When the syrup threads, turn it into the egg in a fine stream, beating till smooth, but not thick enough to drop. Flavor,

and pour over cake, spreading with a knife. If beaten too long, thin with a few drops of lemon juice or boiling water, and wet the knife in cold water.

CHOCOLATE ICING OR FILLING

Granulated sugar, 1 c. Unsweetened chocolate, 2 oz.
Water, 2 tb.

Scrape the chocolate fine, mix it with the sugar and water, and simmer about twenty minutes, or till thick enough to spread. Spread while hot on the cake.

LEMON SAUCE

Sugar (brown or white), $\frac{1}{2}$ c. Butter, 2 tb.
Boiling water, 1 c. Lemon juice, 1 tb.
Cornstarch, 1 tb.

Mix the sugar and cornstarch, stir into them the boiling water, and boil five minutes. Take from the fire, and add butter and lemon juice.

Variations. — 1. Boil the thinly shaved rind of half a lemon in the water, straining it out before adding the water to the sugar and cornstarch. 2. Add one well-beaten egg after taking the sauce from the fire.

A *fruit sauce* may be made by thickening the syrup from canned fruit with cornstarch. If no more sugar is required, how will you keep the cornstarch from lumping?

HARD SAUCE

Butter, $\frac{1}{4}$ c. White of 1 egg.
Powdered sugar, 1 c. Vanilla extract, 1 t.
Grated nutmeg, $\frac{1}{8}$ t., or $\frac{1}{8}$ of a nutmeg.

Cream butter and sugar, add the white-of-egg unbeaten and the vanilla, and beat together thoroughly. Heap roughly in a small glass dish, grate nutmeg over the top, and keep cool until served.

DESSERTS

The making of elaborate desserts, except for special occasions, is a waste of time. A rich pudding is unsuitable after a hearty dinner; fruit is the best dessert after such a meal. Jellies, custards, creams, and combinations of these with fruit, when a part of the meal and not eaten to please the taste after hunger is satisfied, are desirable and wholesome.

Remarks about the desserts for which recipes are given.

— Some dessert dishes have been given under other headings. Caramel Custard is a variation of Cup Custards (p. 92). Bread Puddings are baked custards thickened with bread crumbs. They should be soft, like custard. In making soft custard, use the same care that you have in making sauces thickened with eggs. In using tapioca¹ or cornstarch, see that the starch is thoroughly swollen and cooked. What reason is there for cooking it thoroughly? Starch mixtures stiffen in cooking; if to be moulded, take care not to have them more than just stiff enough to hold their shape when cold.

¹ Tapioca is made by heating the starch obtained from the roots of the manioc, or cassava, a tropical plant.

CARAMEL CUSTARD

Eggs, 3.	Extract of vanilla, $\frac{1}{2}$ t.
Sugar, $1\frac{1}{2}$ tb.	Scalded milk, 1 pt.
Sugar for caramel, 1 c.	Water, 2 tb.

Melt the sugar for caramel, stirring constantly until it is light brown. Reserve one-half of it. Butter custard cups and pour a little caramel into each; tip the cups so as to coat them with it.

After beating the eggs slightly, beat in the sugar, stir in the milk and vanilla, and fill the cups nearly full. Bake like cup custards, and when cold turn them out, one on each serving plate. Serve with cold Caramel Sauce.

Another method. — Omit the one and a half tablespoonfuls of sugar, and mix the caramel into the custard instead of pouring it into the cups.

To make Caramel Sauce, add to the caramel reserved half a cup of *boiling* water, and keep it hot till the caramel dissolves. If the water is not boiling, the caramel will spatter.

PLAIN BREAD PUDDING

Milk, 1 qt.	Salt, $\frac{1}{2}$ t.
Sugar, $\frac{1}{2}$ c.	Bread crumbs, 2 c.
Eggs, 2.	Spice, $\frac{1}{4}$ t.

(If to be eaten without sauce, add 2 or 3 t. melted butter.)

Soak the bread in the milk. Beat the eggs slightly. Beat into them the sugar. When the crumbs become soft, add eggs and sugar, spice, and salt, and mix thoroughly. Turn into a buttered dish. Bake until a knife inserted in the pudding comes out clean.

Variations of Bread Pudding. — 1. Add *one cupful of boiled raisins, citron, and currants mixed.*

2. Separate the eggs, add only the yolks to the pudding. Beat the whites stiff; beat into them *two and a half tablespoonfuls of powdered sugar*; spread them roughly over the pudding; and return it to the oven for two minutes, or till a delicate brown.

3. **Queen of puddings.** — Like variation 2, except omit spice, flavor with *one and a half tablespoonfuls of lemon juice* and spread it over with *jam or jelly* before covering it with meringue.

PLAIN SOFT CUSTARD

Scalded milk, 2 c.	Sugar, 4 tb.
Egg-yolks, ¹ 3.	Salt, $\frac{1}{8}$ t.
	Vanilla, $\frac{1}{2}$ t.

Beat the eggs slightly, beat into them the sugar and salt, and stir in slowly the hot milk. Pour into a double boiler, and cook, stirring constantly, until the custard is thick enough to coat the spoon. Strain at once through a fine strainer into a cold pitcher. When cool stir in the vanilla, and pour into a glass dish or glass custard cups for serving.

If the custard cooks a moment too long, it will curdle. It is safer to take it from the fire before you think it quite done, as the heat of the boiler cooks it even while it is being turned out. If it begins to curdle, set the upper part of the

¹ Whole eggs may be used, but they do not make so smooth a custard. When eggs are expensive, two yolks may be used instead of three, if half a tablespoonful of cornstarch is added. Mix the cornstarch with a tablespoonful of the cold milk and stir it into the rest.

boiler immediately into a pan of cold water, and beat the custard energetically with a Dover egg-beater till smooth.

APPLE TAPIOCA

Pearl or granulated tapioca, 4 tb.	Sugar, $\frac{1}{2}$ c.
Tart apples, 6.	Cinnamon or nutmeg, $\frac{1}{4}$ t.
Boiling water, 1 pt.	Salt, a f.g.

Soak the tapioca overnight in one cupful of cold water. Core and pare the apples, slice one of them, and cook it with the tapioca in the boiling water till the latter is translucent. Place the rest of the apples upright in a buttered baking-dish, sprinkle over them the sugar and spice, pour over them the tapioca mixture, and bake till they are tender. Serve with sugar and cream.

CORNSTARCH MERINGUE

Milk, 1 qt.	Granulated sugar, $\frac{1}{4}$ c.
Cornstarch, $\frac{1}{4}$ c.	Vanilla extract, 1 t.
Eggs, 2.	Powdered sugar, 6 tb.

Scald the milk in a double boiler, and stir into it the cornstarch just moistened with cold water. Cook directly over the heat till it comes to the boiling-point; then remove at once. Separate the eggs; beat the yolks slightly by themselves, then with the granulated sugar; stir these into the thickened milk; cook all together for one minute; add the vanilla; and pour into a baking-dish.

For the meringue. — Beat the whites till frothy, add the powdered sugar, and beat again. When stiff enough to hold its shape, spread the meringue over the pudding, heaping it

in the middle, sprinkle with powdered sugar, and brown slightly in a warm oven. Serve cold.

CREAMY RICE PUDDING

Milk, 1 qt.

Sugar, $\frac{1}{2}$ c.

Rice, $\frac{1}{2}$ c.

Grated nutmeg, f.g.

Salt, $\frac{1}{4}$ t.

Wash the rice (p. 75). Mix the ingredients in a pudding-dish and bake for three or four hours, stirring in the brown crust as it forms. Or cook for one hour on top of the stove and for one hour in the oven. Serve cold.

Half a cupful of raisins may be cooked in this pudding.

SECTION 3. ICE-CREAM AND WATER-ICES

In summer no other dessert is so welcome as ice-cream. With bread and butter, it is a sufficient lunch on a hot day.

Ice and salt form a freezing mixture. — When ice and salt are mixed, a double action takes place: the salt makes the ice melt, and the melting ice dissolves the salt. We have already observed that heat is used up in changing matter from the solid to the liquid form (pp. 27 and 55). Melting ice and salt reach a temperature below the freezing-point of water. If we pack them around some other liquid, they draw the heat from it so fast that it freezes. This is why we use a mixture of salt and ice to freeze ice-cream.

Experiment. — Fill a cup with cracked ice; take the temperature of the ice with a thermometer. How cold is the ice? Mix four table-spoonfuls of ice-cream salt with the ice, and watch the thermometer. When the mercury stops falling, see what degree of cold it registers.

DIRECTIONS FOR FREEZING CREAM

Making ready. — Put the ice into a strong canvas bag, or wrap it in a piece of stout cloth, and pound it fine. Use ice-cream salt; fine salt will not do. Scald can, dasher, and cover. Fit the can into the socket in the pail, pour in the mixture to be frozen, put on the cover, adjust the cover to the cross-piece, and turn the crank to make sure that all is in working order.

Packing. — Fill the space between the can and the pail with alternate layers of ice and salt, putting in three measures of ice, then one of salt. The ice and salt should come a little above the height at which the cream will stand in the can. As the mixture expands in freezing, fill the can not more than three-fourths full. Pack ice and salt solidly, turning the crank a few times to let the mixture settle.

Freezing. — Turn the crank slowly and steadily until the cream is rather stiff, then turn more rapidly. Do not draw off the water unless it stands so high that there is danger of its getting into the can. The cream should take about twenty minutes to freeze. Cream frozen too rapidly, or not well stirred, is coarse-grained.

When the dasher turns very hard, the cream is sufficiently frozen. Remove the crank, wipe the outside of the cover and the upper part of the can (to avoid letting in any salt water), and take off the cover. Take out the dasher. Scrape the cream from the dasher and from the sides of the can, and pack it down level. Put a cork into the hole in the cover, and replace it. Draw off the salt water, repack with

ice and salt, and cover with an old blanket or a piece of carpet. Let the cream stand in the freezer at least one hour, two, if possible, to "ripen" before serving. This greatly improves its flavor.

Water-ices. — Freeze water-ices like cream, except that the crank need not be turned constantly. A few turns every five minutes is enough.

How to make ice-cream without a freezer. — Ice-cream can be made in a tin pail packed in a wooden pail. Whirl the pail round by its handle, taking off the cover occasionally to scrape down and beat the cream. A small quantity can be made in a baking-powder can set into a pail or saucepan. Before using the can, fill it with water to see if it leaks. Most cans require soldering. A tinman will do it cheaply, or you can get a stick of solder and do it yourself.

PLAIN ICE-CREAM (FRENCH ICE-CREAM)

By varying the flavor this cream may be used as the foundation for any kind of ice-cream. It may be made with three eggs and no cream, but even half a cupful of cream is a great improvement.

Milk, 1 pt.
Sugar, $\frac{3}{4}$ c.

Flour, 1 tb.
Thin cream, 1 pt.

Eggs, 2.

Scald the milk, mix the sugar, flour, and eggs together, and make a custard according to the directions for making Soft Custard (p. 285). When cold, stir the cream and flavoring into it, and freeze. Fruit must not be added until the cream is about half-frozen.

Flavorings. — Vanilla Cream. Add one tablespoonful of vanilla, just before freezing. — **Chocolate Ice-cream.** Add two ounces of unsweetened chocolate, melted, or one-fourth cupful of cocoa, and an extra one-half cup of sugar to the custard and cook until smooth. — **Strawberry Ice-cream.** Add one box of berries, crushed, and an extra cup of sugar. — **Peach Ice-cream.** Add one quart of peaches, pared and mashed, and from one-half to three-fourths of a cup of sugar.

AMERICAN ICE-CREAM

Thin cream, 1 qt.

Sugar, $\frac{3}{4}$ c.

Vanilla, 1 tb.

Mix the ingredients and freeze. This ice-cream may be varied, as plain ice-cream is, by using other flavoring, or crushed fruit, or fruit-juice.

Instead of one quart of thin cream, one pint of thick cream and one pint of milk may be used.

JUNKET ICE-CREAM

Lukewarm milk, 1 qt.

Sugar, 1 c.

Cold water, 1 tb.

Junket (rennet) tablet, 1.

} To be made into junket according to the recipe on p. 98.

Thick cream, 1 pt.

Vanilla, 2 tb.

or

or

Thin cream, 1 qt.

Crushed and sweetened fruit.

Make the junket. When it has set, stir in the cream, and flavoring or fruit, and freeze.

Junket gives the ice-cream more body than could otherwise be obtained without using more cream. (What is the effect of rennet on milk?)

LEMON ICE

Lemons, 4 large ones.

Sugar, $1\frac{1}{4}$ lb.

Oranges, 1.

Water, 1 qt.

Make a syrup of the sugar and water by boiling them together five minutes. Add the grated rind of the orange and of one lemon. Add the juice of the orange and lemons. When the syrup is cool, strain and freeze.

For sherbet, add the beaten white of an egg. Sherbet does not melt so fast as water-ice does.

SECTION 4. PASTRY — PIES

Review Biscuit, p. 105, and Chap. 7, Fats and Oils.

Tender, crisp pastry is more easily digestible than that which is tough or soggy.

To make pastry flaky all the ingredients must be kept cold, and the paste must be handled lightly and rapidly at every stage.

The following recipe makes pastry for one upper and one under crust. The fat may be butter, lard, a substitute for butter or lard, or two of these.

PASTRY

Flour, $1\frac{1}{2}$ c.Fat, $\frac{1}{2}$ c.Salt, $\frac{1}{4}$ t.

Cold water (ice-water, if possible), about 3 tb.

Mix flour and salt. Cut in the fat with a fork. Add water till the mass just holds together. Roll out, with light strokes forward and to right and left. Pat gently with the rolling-pin. Do not bear down or roll backward and forward. Try to keep paste rectangular. When about half an inch thick, fold the right-hand third over, then the left-hand third.

The paste is now in three layers.

Roll out again. Lift the edge nearest you and roll the paste up. If it sticks at any time, free it with a floured knife and sprinkle flour under it. If it is not to be used at once, wrap it in a damp cloth and put it in a cold place.

A plainer pastry may be made with less shortening and the addition of $1\frac{1}{2}$ t. baking-powder.

APPLE PIE (with upper crust only)

Fill enamelled pie-plate one inch or more deep, rounding full of sliced apples. Sprinkle with sugar (about one-half cup for moderately tart apples) and with nutmeg or cinnamon. Add, if you like, one teaspoonful of lemon juice and one of butter, cut into bits. Invert a small cup in the centre to hold up the crust.

Cut off a little less than half of the roll of pastry. Place cut end up. Roll it out into a sheet as nearly circular as possible and about one inch and a half greater in width than the top of the pie-plate. It should be about one-eighth of an inch thick. Double it. Make a few cuts along the doubled edge to let out steam. Lay the doubled pastry on one-half of the pie. Unfold it. Turn the edges under and press them down. Trim edges to within three-fourths of an inch of the plate. Bake until the crust is a delicate brown, about 35 minutes.

Peach, rhubarb, and other fruit pies may be made in the same way, except that spice is not used, and the quantity of sugar must be varied according to the acidity of the fruit.

When using lemon, cream, custard, or similar filling,

bake the under crust first by itself. If crust and filling are cooked together, the crust will not bake crisp enough to be wholesome.

LEMON PIE (with under crust only)

Line pie-plate with pastry rolled out as directed above. Fit it in easily. Do not stretch it. Trim close to plate, slanting knife outward. Prick it with a fork and bake. Watch for blisters which form during baking and prick them before they harden.

FILLING

Sugar, $\frac{3}{4}$ c.	Butter, 1 t.
Cornstarch, 2 tb.	Yolks of 2 eggs, beaten.
Flour, 2 tb.	Lemon juice, 3 tb.
Boiling water, $\frac{3}{4}$ c.	Grated rind of 1 lemon.

MERINGUE

Whites of 2 eggs.	Powdered sugar, 2 tb.
Lemon juice, 1 tb.	

Mix the sugar, cornstarch, and flour. Stir in the boiling water gradually. Cook till thick, stirring. Stir in the other ingredients and let mixture cool. When the crust is baked, turn the mixture into it. Spread the meringue over the top and return to the oven until the meringue is slightly brown.

PIE MADE WITH TWO CRUSTS

Line a pie-plate with pastry as directed above. Put in the filling. Moisten the rim of the pastry with cold water. Put on the top crust. Press the edges together and trim.

BRIEF REFERENCE LIST

For further development of topics treated in this chapter see: —

FARMER: *Boston Cooking-school Cook Book.*

CHAPTER X

THE PRESERVATION OF FOOD

SECTION 1. MICROÖRGANISMS IN RELATION TO FOOD

Vast hordes of tiny toilers are working in our service night and day to keep the world wholesome and all the races of beings supplied with life-stuff. — T. M. PRUDDEN.

We have learned that mould, yeast, and bacteria are microscopic plants (pp. 30, 128). Collectively they are called *microörganisms* (meaning *little live things*). How does yeast make bread light? How do bacteria make milk sour? Under what conditions does mould grow best?

Yeast causes fermentation. Some bacteria cause fermentation, but more cause that unpleasant kind of decomposition called putrefaction. Carbohydrate foods tend to ferment; protein foods tend to putrefy. In foods containing both carbohydrate and protein, whichever process starts first is likely to prevent or to check the other. The enzymes (p. 131) which exist in most foods also tend to decompose them.

A STUDY OF BACTERIA

Experiment in growing bacteria. — Expose a little clear, cool soup-stock to the air for a few minutes; then cover it with a piece of clean glass, set it aside in a rather warm place, and look at it every day. What

happens to it? How does it smell after a few days? What do we say has happened to it?

If we should examine a speck from one of the cloudy spots on soup-stock, under a microscope, we should see many bacteria.

Bacteria compared with yeast. — Bacteria are single-celled forms of plant-life, like yeast; and, like it, they multiply when they have warmth and food and moisture. They exist in far greater numbers than yeasts do, however, swarming in the

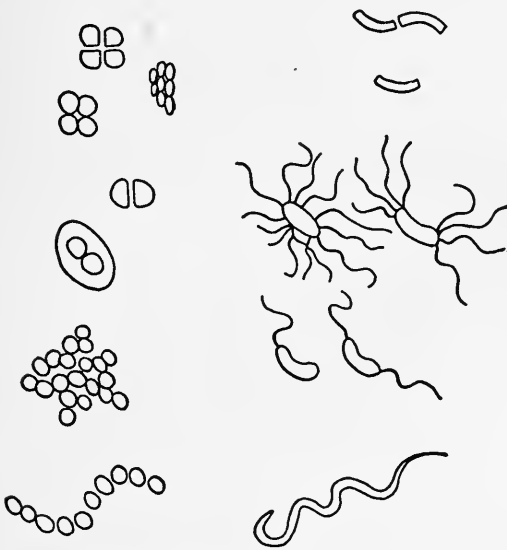

FIG. 15.—Shapes and groupings of different kinds of bacteria (much enlarged).



FIG. 16.—Bacteria causing typhoid fever, as seen under the microscope.

air, in water, in the ground. Some are shaped like lead-pencils, others like eggs or billiard-balls, and still others like corkscrews. One kind is so small that fifteen hundred in a row would hardly reach across the head of a pin.

The life-history of bacteria. — Bacteria multiply by dividing themselves in two, repeating this process so frequently that were there food and room enough for them all, the world would soon be crowded with them. But they

die by millions constantly, one kind overcoming another, while all kinds are destroyed by the occurrence of conditions unfavorable to life. Some kinds of bacteria form spores (p. 128). Spore-formation corresponds in a way to the going to seed of bigger plants, when winter comes on. Spores are usually very hard to kill. They seem able to last forever, ready to spring into activity when right conditions return.

Many kinds of bacteria are harmless. Some are useful. Even those that are troublesome when they attack the food we want to keep do good when they decompose such things as the dead bodies of animals, dead plants and leaves, manure and other waste. They feed upon these, and break them down into inorganic substances suitable to be taken up by plants and again built into living matter, perhaps to become food for animals and men. Thus bacteria form an invisible link between the soil and ourselves, a link essential to life on the earth.

Ways of preserving food. — Conditions favorable to the growth of yeast being, in general, favorable to the growth of bacteria and mould,¹ the way to keep all microorganisms from destroying food is to provide conditions just the opposite of those we provide for yeast in bread-dough. We may keep the food very cold, make it very hot, dry it, or since we cannot take out of it the food microorganisms live on, put into it something to kill them or at least to check their growth. (See disinfectant, p.30.) Any substance used in food for this purpose is called a **preservative**. Salt, vinegar, alcohol, spice, and sugar (in large quantities) have long been

¹ Except that yeasts and moulds require air, and many bacteria do not.

used as preservatives. Would a *little* sugar hinder or favor the growth of yeast? Is alcohol a desirable preservative? (See p. 144.) Wood-smoke deposits substances which have a preservative effect. What foods are smoked? All chemical preservatives, including benzoate of soda and "canning-powders," are objectionable, even in small quantities. There is no need of them in food fit to eat, and they should not be used to conceal the condition of unfit food. Meat, fish, poultry, eggs, butter, and fruit may be kept for months in cold storage. They undergo some change, however, and are likely to spoil quickly when taken out.

The most effective way to keep food is to *sterilize* it; that is, to cook it enough to free it from all living microorganisms. If we do this and then seal it up so that no more can get in, it will keep indefinitely. This is done in canning.

BRIEF REFERENCE LIST

For further development of topics treated in this section see:—

BUCHANAN: *Household bacteriology*. Ch. 2-9 inclusive, 23, and 25, pp. 223-228; ch. 24, Alcoholic fermentation of fruit juices.

ELLIOTT: *Household bacteriology*. Pp. 47-55 and 68-74.

PRUDDEN: *Story of the bacteria*.

CONN: *Bacteria, yeasts, and molds in the home*. (Especially ch. 10, Preservation of food; 11, Preservatives, and 12, Preservation by canning. For experiments see pp. 271, 276, 280.)

GREER: *Food — what it is and does*. (Functions of bacteria. Nitrogen and carbon cycles in nature, pp. 72-74.)

U. S. DEPT. OF AGRICULTURE: *Farmers' bulletin*: 375. Care of food in the home.

SECTION 2. CANNING

Review composition and food value of fruits, p. 229; fruits must be clean, p. 231; and text on Sugar, Chap. 9, Sec. 1.

Fruit and tomatoes are the easiest foods to can because they are the easiest to sterilize. The reasons for this are three. 1. They are attacked chiefly by yeasts, and by bacteria which do not bear spores, both of which are quickly killed by boiling. 2. They are acid, and hot acid helps to kill microorganisms. 3. They are readily penetrated by heat. Our aim in canning is to sterilize the fruit without injuring its appearance and flavor.

One secret of success in canning is cleanliness. Cleanliness means fewer microorganisms to be killed. For this reason, keep the room as free as possible from dust; keep the table, your hands, and your clothes clean while you work; and wash all the utensils just before beginning work, rinse them with boiling water, and let them dry *without wiping*. Dish-towels are not sterile.

To sterilize jars. — Put the jars in a pan or pail, cover with cold water, let it come to a boil and boil for ten minutes. This is an extra precaution, not necessary except when fruit is cooked before being put into jars. When it is done, covers and rings should be sterilized in a smaller vessel in the same way.

To test a jar. — Fill a jar with water, fasten on ring and cover, and invert. If it leaks, either the jar is imperfect or the rubber poor. Use no jar that cannot be made absolutely tight.

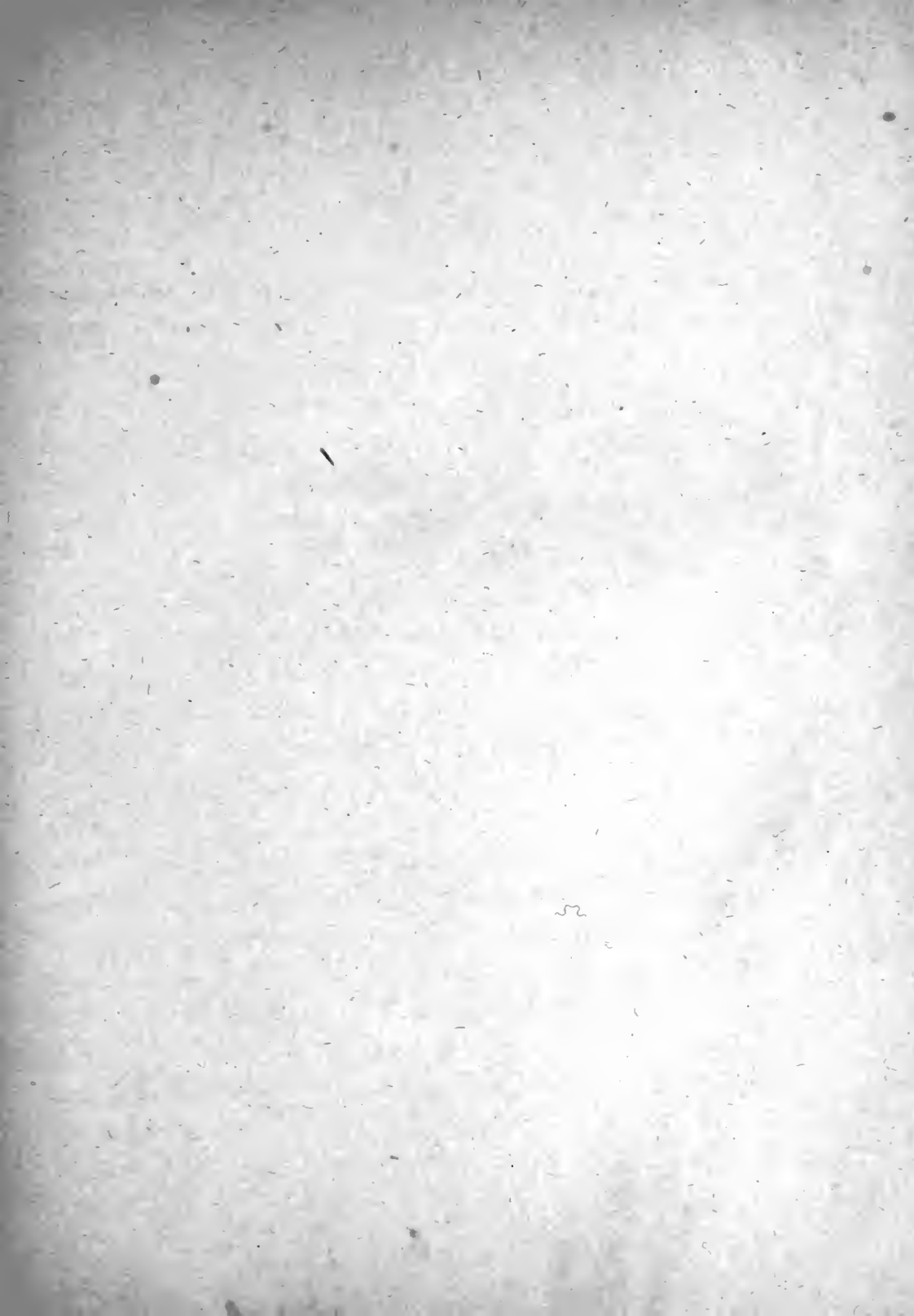
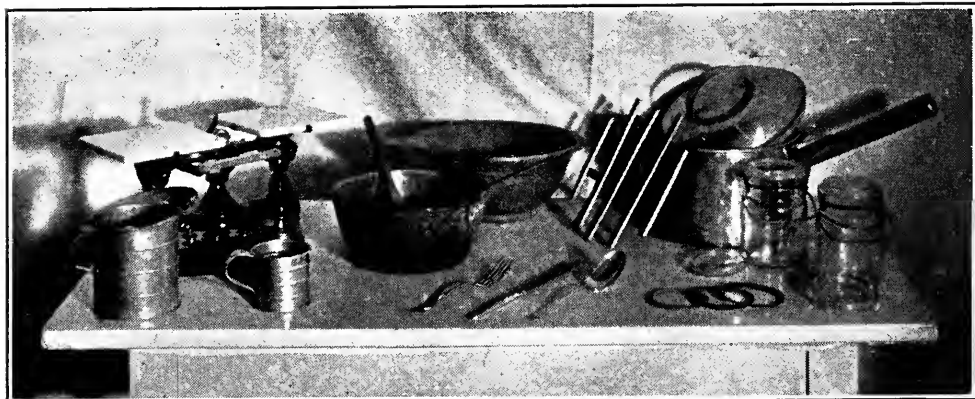

PLATE XIV.



UTENSILS USED IN CANNING.



SEALING FRUIT JARS.

The right sort of fruit to can. — Can each fruit in its season when it is best and cheapest. It is best for canning just before it is quite ripe. The better the condition of the fruit the easier it is to sterilize. So use only fresh, clean, sound fruit, and see that no soft berries or spoiled bits get into the cans.

Preparing the fruit. — Wash all fruit. Hull berries. Take out stems and trash. Peel or pare large fruits. Pour hot water over peaches and tomatoes to loosen the skin. Core and quarter apples and quinces. Quarter large tomatoes. Can small ones whole. Peaches may either be canned whole, or halved and stoned. Halves pack better. A few peach stones canned with them improves the flavor. Stoned cherries pack closer than whole ones and can be sterilized quicker. Prick whole cherries and plums. If peeled fruits are not to be put in jars at once, drop them into water made slightly acid with lemon-juice or vinegar.

Sterilizing the fruit in the jars in a closed vessel has these advantages. — It is the simplest method. It best retains the flavor of the fruit. It avoids exposing the fruit after it has been sterilized.

This method requires the following outfit: a wash boiler, pail, or any vessel with a tight-fitting cover, large enough to hold several cans; a rack to fit the bottom of the boiler and keep the jars from bumping and breaking when the water boils (this may be a piece of heavy wire netting or it may be made at home of strips of wood); quart or pint glass jars (the jars with glass covers and metal springs are best); a new rubber ring for each jar (old rubber may

not be air-tight); large bowl or enamelled pan for fruit; plated knife and fork; plated or enamelled spoon; quart measure; half-pint measure; scales; saucepan for syrup. Avoid iron and tinware in canning.

Addition of sugar and water to fruit. — Fruit to be used for cooking may be canned without sugar. If to be used for sauce, it is best to sweeten it when it is canned. The sugar should be proportioned to the acidity of the fruit. The easiest way to do this is to dissolve the right amount for each jar (usually from two to four ounces for a pint jar) in hot water and pour it in, filling up the jar with more hot water if necessary. The water should be proportioned to the juiciness of the fruit. This regulates itself fairly well, as in general the juiciest fruits are the small ones that pack close and leave little space for liquid. The sugar may be made into a syrup. For a light syrup, use one-half pound of sugar to one quart of water. Boil together until the sugar is dissolved. If a scum rises, remove it. A sweeter syrup may be used for more acid fruits and for small fruits which leave little space for syrup. It may be necessary to find by trial how much syrup one can of fruit will hold before determining the proportions of sugar and water.

Add salt to vegetables, using one-fourth to one-half teaspoonful to a pint jar, and fill up with cold water.

Time required for sterilization. — If packed in quart jars, sterilize berries from ten to twenty minutes, other small fruits and cut-up fruits for twenty-five, pears and whole peaches for thirty, quinces for one hour or more, according to size of pieces, tomatoes fifteen to twenty minutes. The

time for quinces may be shortened and the quinces improved by cooking them for ten or fifteen minutes before putting them in the jars. For fruit in pint cans, only two-thirds as much time is required.¹ *The water must boil every minute.*

Directions for canning. — Pack fruit compactly in jars. To make it pack better, it may be put in a strainer or piece of cheesecloth and lowered into boiling water for about one minute. This is called “blanching.” Blanch fruit in small lots, that the water may not be cooled much. Press fruit gently down in jars with spoon or small wooden spatula. Fill jars with syrup. Release any air-bubbles by slipping knife or spatula down between fruit and jar. Put on rings and cover without fastening them down. Place jars on rack in boiler. Pour in cold or warm water (warm saves time) to a depth of two or three inches. Put on the boiler cover. Bring water to a boil and boil as long as required. Remove from the heat, fasten down covers, take jars out, and let them cool as quickly as possible. Letting them cool down slowly in the water softens the fruit and makes the juice cloudy. If, when sterilization is complete, there is more than half an inch of space between fruit and cover, the contents of one jar may be used to fill the rest before the covers are fastened down. Five minutes more boiling is then required. This is troublesome and is unnecessary if jars have been properly packed.

¹ These directions apply to fruit bought in towns and cities. Less time is required for fruit freshly picked. Ten minutes for quart jars, five minutes for pint jars of freshly picked berries is sufficient. The shorter the time of sterilization the better the berries retain their flavor, shape, and color.

A steamer may be used instead of a boiler to sterilize fruit in jars. Or the jars may be set in a pan of water or on a sheet of asbestos in the oven. The oven method shrinks the fruit more and takes more fuel.

The kettle method of canning. — Cook the fruit in the syrup in an enamelled kettle until it is tender. Take jars, rings, and rubbers as you need them from hot water in which they have been sterilized. While filling the jar let it stand on a hot wet cloth. Transfer the fruit quickly from kettle to jar, using a wide-mouthed funnel and a dipper or large spoon. Fill jar to overflowing with syrup. Put on ring and cover and fasten cover down. Wipe off jar.

Strawberries may be canned to advantage by this method without the addition of water, which they do not need. Hard fruits such as quinces and pineapples should be cooked in clear water before sugar is added.

Canning foods other than fruit. — Meat, fish, and many vegetables, notably corn and beans, are hard to sterilize because they contain spore-bearing bacteria and are not acid. In factories, these and many other foods are canned by steam under pressure. Vegetables may be canned at home by boiling them several times, generally on three successive days, to kill spores which have developed after previous boilings. This method is called intermittent sterilization. Canning outfits, some for steaming under pressure, are made for home use in the country. It does not pay city-people to buy vegetables to can. They cost too much and are not fresh enough.

Directions for canning string beans. — If fresh from the garden and tender, these may be canned like fruit. Wash

and string them, and break them into short pieces. Blanch from five to ten minutes, removing them when soft enough to bend without breaking. Pack in jars, fill with cold water, and add one teaspoonful of salt to a quart jar. Boil quart jars one hour. If beans are not freshly picked, boil for one hour, fasten down covers, remove jars, set aside till the next day, and boil again for one hour.

Pickling is preserving in brine or vinegar, to which sugar and spice are often added. Now that fresh or canned vegetables can be obtained the year round, there is not the need for pickling them that there was in our grandmothers' day. Even as a condiment, pickles and spiced preserves should be used sparingly, and not at all by children. They stimulate digestion, but tend to weaken it in the long run.

BRIEF REFERENCE LIST

For further development of topics treated in this section see:—

OLSEN: *Pure foods*. Ch. 12.

ROSE: *Preservation of food in the home*. Parts 1, 2, 3. Cornell reading course.

U. S. DEPT. OF AGRICULTURE: *Farmers' bulletins*: (359, Canning vegetables in the home; 203, Canned fruits, preserves, and jellies. Also circulars on girls' canning and home demonstration work.)

NORTH CAROLINA DEPT. OF AGRICULTURE. V. 31, No. 5, May, 1900. Home canning of fruits and vegetables. (Sent free to citizens.)

SECTION 3. JAM AND JELLY; PECTIN

Before the principles of sterilizing were understood, fruit was preserved by cooking it with its weight of sugar. Such "preserves" are rarely made now. But jams, jellies, fruit

butters, and marmalades contain enough sugar to preserve them. It is well, however, to sterilize, or at least to dip into boiling water, the tumblers or jars which are to hold them, and they must be covered air-tight to protect them from mould. Sugar should be added hot in making either jam or jelly. Measure it into a pan and set it into the oven. Take care that it does not scorch.

Jam is made of fruit and sugar cooked together till thick. Any kind of fruit may be used. Fruit butter is similar to jam, but thinner and less sweet. For jam allow three-fourths of a pound of sugar to one pound of fruit; for fruit butter, one-half to three-quarters of a pound of sugar to one pound of fruit.

Directions for making Blackberry or Raspberry Jam. — Pick over and wash berries. Put them, a cupful or so at a time, into a preserving kettle, mashing those in the kettle before adding more. Cook slowly, stirring, and adding a little water if necessary to prevent sticking. Stir in the hot sugar slowly. Cook until thick. Put into glasses or jars. When cold, cover with paraffin, and put on tin covers.

Paraffin for covering jelly or jam should be hot, not merely melted. Pour on a layer one-fourth of an inch deep. Examine after it has cooled. If the paraffin shows bubbles, add another layer.

Marmalade, as ordinarily made, is jam of jelly-like consistency.

Pectin. — The jellying substance in fruit-juice is pectin.¹

¹ Pectin appears in several forms (pectose, pectocellulose, pectic acid, and the like). Just which of these are present in raw juice, in cooked juice,

Pectin will not jelly unless acid is present and to make a *good* jelly sugar is necessary. It is important that the sugar be proportioned rightly to the pectin. Too little sugar makes tough jelly. Too much makes soft jelly, or even syrup. No exact rule can be given for the amount of sugar, because the amount of pectin varies in different fruits, and in different lots of the same fruit. After a rain currants are likely to be more watery than usual, and so to contain a smaller percentage of pectin.

Test for pectin. — Prepare, in separate test-tubes or small dishes, one tablespoonful each of lemon-juice, orange-juice, juice squeezed from raw currants, juice cooked from currants, and any other fruit-juices, from either raw or cooked fruit. To each portion of juice add one tablespoonful of grain alcohol. Note which juices contain much pectin, which a little, and which none at all.

Melt a little jelly, and test for pectin with alcohol.

Cooking appears necessary to extract pectin thoroughly from fruit. This may be because much of it is in the cell-walls of the fruit, and particularly in the harder parts, such as skin and core. In lemons and other citrus fruits much of the pectin is contained in the white inner skin. Whole oranges and grapefruit are among the best fruits for making marmalade.

Pectin acts much like gelatin, but in composition resembles carbohydrates. What do you know of the jelly-making properties of starch? of gelatin? Pectin is found largely in the framework of fruits and vegetables. What is gelatin made from?

and in jelly has not been determined. The change from liquid to jelly involves taking up water but apparently no marked change in composition.

The utensils needed for jelly-making are a large enamelled kettle, one or two large bowls or enamelled pans, quart measure, silver spoon, wooden masher, two yards of firm cheese-cloth doubled to make a square, jelly tumblers, and paraffin. A clean strong stick is convenient to hang the cheese-cloth on while the juice drips. A jelly-bag and a wire frame can be bought.

The best fruits for jelly are currants, crab-apples, partially ripened grapes (especially wild grapes), and tart apples. Cranberries also jelly easily. Blackberries and quinces come next. In the South and Southwest logan-berries and loquats are much used. Apple-juice is often combined with other juice lacking in pectin or in acid.

Proportion of sugar to fruit. — Currants and partially ripened grapes usually require as much sugar as juice. Red raspberries, blackberries, and fruits such as sour apples, crab-apples, and cranberries, to which considerable water must be added, take about three-fourths as much sugar as juice.

The best time to add the sugar is about midway of the cooking of the juice; after about five minutes for currants, after ten or fifteen minutes for other fruits.

Directions for making Currant Jelly. — Wash and drain the currants. They need not be stemmed. Put them into the kettle, a pint or so at a time, and mash them as they are put in. If they seem very watery, add no water. Otherwise add about one cupful of water to 5 or 6 quarts of currants. Stir and mash them while they heat. When they are hot and the juice is flowing, wring the double square of cheese-

cloth out of hot water and lay it over a bowl or pan. Transfer the mass of fruit to it, tie the corners, and suspend it over a bowl or pan by a stick laid across the backs of two chairs, or the rungs of a stool upside down. Let it drip until most of the juice is out, for from 30 minutes to one hour. Measure the juice. Measure an equal quantity of sugar. Heat the juice in a kettle, the sugar in the oven. Boil the juice for five minutes, removing scum as it rises. Add sugar. Boil three to five minutes longer. Test by dropping a little on a cold plate.¹ When the plate can be stood on edge without making the jelly run, remove from the fire, and dip, or better, pour into glasses. When the jelly has set firmly, cover with paraffin. (P. 304.)

Put the mass of currants back into the kettle, cover with water, and heat again to obtain more juice. Proceed with this juice as with the first lot. Before adding sugar to it, take out a little and test for pectin. If much is found, a third lot of juice may be extracted and made into jelly.

If preferred, the first juice may be allowed to drip several hours or overnight, the bowl removed, and a second lot of juice squeezed out. This juice will make a less clear jelly, which can be used for jelly-cake, etc.

Directions for making Apple or Crab-apple Jelly. — Wash, stem, and wipe crab-apples, or *tart* apples. Cut into quarters. Do not core. Barely cover them with cold water. Cook till soft. Mash, and let drain in cheese-cloth. Measure three-fourths of a cup of sugar for each cup of juice. Proceed

¹ Another test is the jellifying, or breaking off of the hot mass as it falls from the spoon.

as with currant jelly, adding sugar when the juice has boiled about fifteen minutes.

HELPFUL HINTS ABOUT JAM AND JELLY MAKING

1. Jam may be made from fruit not perfect enough to can, from fruit slightly overripe, and from small pieces left after canning.

2. Jam may be cooked in a fireless cooker. This saves watching and stirring.

3. Jelly, though not of the finest grade, may be made from the cores and parings from apples and quinces cut up for canning.

4. In jelly-making, when much water has to be added to the fruit, the juice must be boiled down to restore its natural composition. Long boiling may destroy the jelling property of the pectin. Therefore use as little water as possible, and avoid overcooking.

5. If after cooking the usual length of time for the fruit in use, the sweetened juice will not jelly, re-measure it, and add to it an equal quantity of juice. Cook again, and test as usual.

BRIEF REFERENCE LIST

For further development of topics treated in this section see:—

OLSEN: *Pure foods*. Ch. 13.

GOLDTHWAITE: *Principles of jelly-making*. (University of Illinois bulletin, v. 11, no. 31, March 30, 1914.)

SNELL: *Household chemistry*. P. 180, Pectin.

NORRIS: *Organic chemistry*. Pp. 320–327, Pectin.

HARRIS: *Jellies, preserves, and marmalades*. Florida State College for Women. Dept. of Home Economics. Extension bulletin No. 3.

CHAPTER XI

FOOD FOR BABIES AND THE SICK

SECTION 1. FOOD FOR BABIES

Review text on Milk in Chap. 3, Sec. 2, also Chap. 10, all of Sec. 1, and text relating to cleanliness and sterilization in Sec. 2.

The best food for a baby is its mother's milk. — This is as perfectly fitted for the baby as a cow's milk is for her calf, the egg for the unhatched chick, the seed for the seedling. It is very important for a baby to have mother's milk, if possible, for the first few months at least.

Feeding a baby on something other than mother's milk is often called *artificial feeding*. A better term is *substitute feeding*. The best substitute we have¹ for mother's milk is fresh cow's milk. Plain milk just as it comes from the cow is not good for most babies under one year old. This is because it differs in many ways from human milk. It has more than twice as much protein,² and only about two-thirds as much sugar.

¹ In some European countries goat's milk is used, and in other parts of the world the milk of other animals. Sick babies or babies with disordered digestion cannot always take cow's milk. This section treats of feeding normal healthy babies.

² AVERAGE PERCENTAGE COMPOSITION OF COW'S MILK AND OF HUMAN MILK

	WATER	FAT	SUGAR	PROTEIN	ASH
Cow's milk	87.25	4.00	4.50	3.50	.70
Human milk	87.30	4.00	7.00	1.50	.20

It has more than three times as much mineral matter. The two kinds of milk contain about the same percentage of fat, but the fat of cow's milk is more solid. The protein too is different. Moreover, the foodstuffs in mother's milk are more easily assimilated by the baby, especially during the first few weeks of life.¹ The nursing baby gets food that is perfectly fresh, alkaline or only faintly acid, and practically free from bacteria. As the baby grows this food changes to meet his needs. The bottle-fed baby's food must be prepared from milk which is usually many hours old, perhaps more than a day old. It is more or less acid and contains bacteria, often in great numbers. It cannot be changed gradually enough to keep it exactly adjusted to the baby's needs.

Modified milk. — We can make cow's milk more digestible and nutritious for the baby by diluting it with water and adding sugar and sometimes other things. Milk so altered is called modified milk. Each baby must have his milk modified to suit his particular needs at a given time. Any one

¹ These differences in composition correspond to differences between a calf and the baby. The calf grows much the faster. It doubles in weight in 47 days. So it needs a much greater proportion of bone and muscle building material than the baby, who takes 180 days to double his weight. The calf is soon going to eat coarse food, and so is provided with four stomachs, which enable it to do more digestive work than the baby can from the first. The baby begins life quite helpless, while the calf in a few hours can walk and almost take care of itself. When the baby is grown up he will far surpass any animal in skill and intelligence. This means that he has to build up a wonderful nervous system from the incomplete one he has at birth, instead of starting life as the calf does with a nervous system practically complete. Human milk provides for all this better than cow's milk does.

can learn to modify milk and prepare bottled food according to instructions, but to decide rightly what food a given baby should have, requires much knowledge and study. The best plan usually is to have a doctor who knows the baby prescribe his food and give instructions for preparing it and for changing it from time to time.

PREPARING THE BABY'S FOOD

To do this right, three things are essential: Good materials, extreme cleanliness, perfect accuracy. Proper utensils help to insure cleanliness and accuracy.

List of utensils needed: —

8 or 10 feeding-bottles.

Corks, preferably rubber, one for each bottle, or Absorbent cotton.

Bottle-brush to clean bottles.

Wire bottle-rack to hold bottles. (If you have a pasteurizer-rack no other is needed.)

Several rubber nipples.

Covered jar or bowl to keep nipples in.

Enamelled or earthen pitcher in which to mix food.

New enamelled saucepan or double boiler for cooking gruel.

Glass jar to keep gruel in.

Measuring-glass, also called a graduate.

Tablespoon and knife for measuring.

Tall cup or quart measure for heating milk.

If cream or top-milk is to be removed, a cream-dipper will be needed.

Care of utensils. — The utensils used in preparing a baby's food should not be used for anything else. Keep them all together and take care of them yourself. Wash

them as soon as you are done with them. Rinse them all over in boiling water. Do not wipe them. Put them away out of the dust where no one will touch them. Rinse them again in hot water just before using them.

Bottles. — Eight-ounce bottles are most frequently used. If the baby takes more than eight ounces at one feeding, use twelve-ounce bottles. Bottles *d* and *e* in Plate XV are well-shaped. Their sloping shape makes them easier to clean than bottles *a* and *b*, which have a pronounced shoulder. The straight bottle, *c*, is the easiest of any to clean, but both the bottle and large nipple to fit it cost more than other kinds. It is not necessary except for a baby who refuses any nipple but the large one.

Get bottles on which the ounces are marked. If one must economize, an accurately-marked bottle may be used for measuring instead of a measuring-glass. Keep on hand at least one extra bottle so that you will not be short if one is broken.

Care of feeding-bottles. — Clean new bottles thoroughly with soap, water, and bottle-brush. Put them into cold water, let it come to the boiling-point and boil for fifteen minutes. Let the bottles cool in the water. This not only sterilizes them (see directions for sterilizing fruit-jars), but makes them less likely to break. As soon as a feeding-bottle has been used, remove the nipple and throw away any milk left in the bottle. Either wash it at once or fill it with cold water and set it in the rack. Clean all bottles thoroughly with soap, water, and brush, before using them again. Just before refilling them, sterilize them in boiling



BABIES' FEEDING BOTTLES, AND UTENSILS USED IN PREPARING MODIFIED MILK.

- Bottles *a* and *b*.
- Large nipple funnel.
- Bottles *c*, *d*, and *e*.
- Nipples.
- Glass to hold nipples.
- Rubber stoppers.
- Bottle cleaner.
- Cream dipper.
- Graduate.
- Jar for gruel.

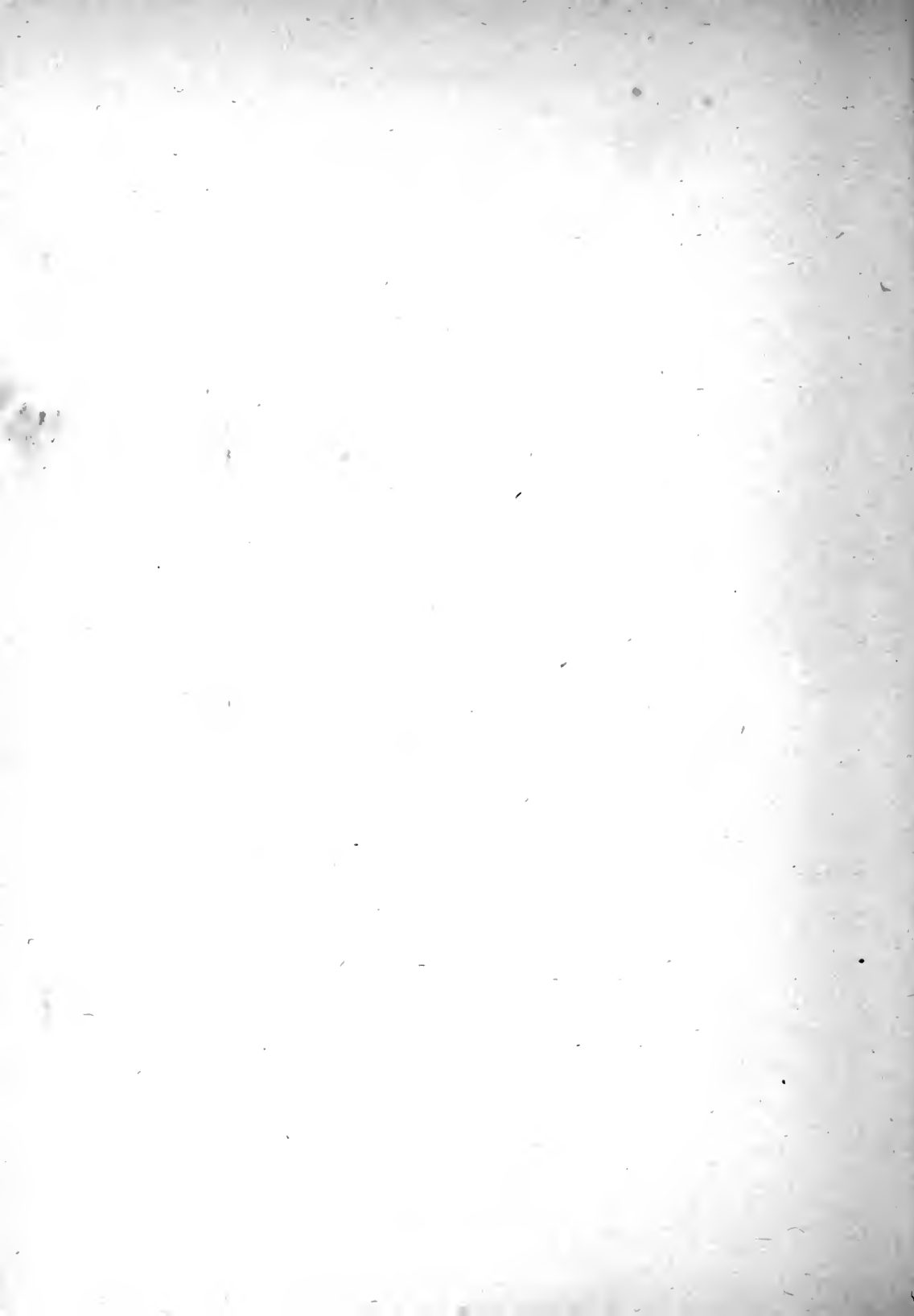

water. Remove bottles from water, plug them with sterile cotton, and let them cool. Or, sterilize them in a covered kettle, and let them cool in the water, not removing cover or bottles till the bottles are to be refilled. Never fill bottles while they are hot.¹

Cotton must be kept in a tightly covered box or jar. Buy sterilized cotton and keep it in a covered box or can. It may be re-sterilized at home if necessary, by baking it in the oven for one hour, wrapped in cheese-cloth.

Nipples. — Select black nipples which do not collapse easily. It is best to buy those without a hole. A hole of the size desired can be made with a red-hot needle. It should allow the milk to drop steadily, but not run in a stream, when the bottle is inverted.

Care of nipples. — Boil new nipples for five minutes. As soon as a feeding-bottle has been used, remove the nipple and wash it under the cold-water faucet, turning it inside out to wash the inside. See that no speck of milk clings to the rim. The nipple may then be dropped into a bowl of boric acid solution kept for the purpose. If preferred, all the nipples in use may be boiled daily, wrapped in a sterilized cloth, and put in a covered jar. They should be so wrapped that one nipple can be taken out without touching or exposing the rest. Boiling the nipples tends to soften them and is unnecessary if boric acid is used.

To make boric acid solution dissolve in one cupful of boiling hot water a heaping teaspoonful of boric acid, and let it cool. It will not dissolve in cold water. Boric acid

¹ As the food is not to be sterilized, it must be kept cold. Why?

is a preservative. What then is its effect on microorganisms? (See ways of preserving food, p. 296.)

Wash and boil corks daily.

LIST OF INGREDIENTS COMMONLY USED IN MODIFYING MILK

NOTE. — The word *milk*, used alone, means ordinary milkman's milk containing about 4% of fat.

Milk	{	Whole milk	
		Top milk	
		Skim milk	
Gruel	{	Oatmeal	
		Barley	
		Sometimes other cereals	
Sugar	{	Cane-sugar	
		Milk-sugar	
		Malt-sugar (“Dextri-maltose,”	“malt-soup
		extract,” or other preparation of maltose).	
Water			
Alkalies	{	Lime-water	
		Magnesia	
		Baking soda	

The milk. — Raw milk is best if it can be obtained very clean. The cleaner it is, the fewer bacteria it contains. Sickness and death are much more common among bottle-fed than among nursing babies. Bacteria in milk cause much of these. If the milk is obtained fresh from the cow, make sure that the cow is healthy and that the milk is drawn and

handled in the cleanliest possible way. When it comes into the house, strain it through several layers of cheese-cloth into sterilized jars or milk-bottles. (How will you sterilize these?) Keep it cool till used.

If milk is obtained from a milkman, buy bottled milk, the cleanest obtainable. Certified milk, guaranteed to be exceptionally clean, is sold at an extra price in some cities. Many cities have milk stations at which high-grade milk is sold at cost or below cost to mothers who otherwise could not afford to buy good milk for their babies. Never use loose milk. (For care of milk see p. 96.)

The milk of Holstein or ordinary grade cows is best. The milk of Jerseys is too rich in fat for most babies. Mixed milk is better than milk from one cow, because it varies less from day to day.

Water. — The milk must be diluted with water to reduce the proportion of protein. For a little baby the milk must be made very weak at first. As the baby gets used to cow's milk, it is made stronger. Water is sometimes added plain, sometimes made into gruel with a cereal. When added plain, it must first be boiled and cooled.

Sugar. — Sugar is not added for the sake of its taste, but for its food value (pp. 266 and 269). Milk-sugar, the kind which Nature provides, is in some ways the best. The best milk-sugar, however, is expensive. Cane-sugar agrees very well with some babies. Other babies do better on malt-sugar than on either milk-sugar or cane-sugar. Dissolve malt-sugar in boiling water, using one ounce of water to one of sugar. Other sugars may be dissolved in the boiled water

after it has cooled, or in the milk. If cane-sugar is not bought in a sealed package, it may not be clean and should be boiled.

Gruels. — The younger the baby, the less starch he can digest. Whether the starch is digested or not, adding gruel to the milk often makes it agree better with the baby. The less fat there is in the food, the more carbohydrate should be added. (Explain why.)

Directions for Gruels. — The easiest way to make gruel is from the flour of wheat, barley, oats, rice, whichever may be ordered. If the unground grain is used, many hours' cooking is required. A gruel may be made thick enough to jelly when cold or thin enough to remain watery.

To prepare barley water, stir together one level teaspoonful of barley flour and enough cold water to make a smooth paste. Stir in two and one-fourth cups of boiling water, and boil gently fifteen minutes. Or cook in a double boiler at least one hour. (Unless you can watch it constantly, it is better to use the double boiler.) If it boils away, add boiling water. When cooked, measure, and, if necessary, add enough boiling water to bring the amount of gruel up to one pint.

Oatmeal water is made in the same way.¹

For barley jelly, follow the same directions, except that 2 to 4 tablespoonfuls of flour is used, according to the thickness desired.

Other kinds of gruels are made like barley water and barley

¹ Oatmeal is laxative. Barley has the opposite effect.

jelly. The gruels should be cold when added to the milk. It is best to make it the night before. Enough for two or three days may be made at one time and kept in a glass jar *if there is an ice-box or other clean, cold place to keep it in.*

MIXING THE FOOD

A recipe for modified milk is called a *formula*. Formulas for babies of different ages and weights have been worked out, according to several different systems. We cannot attempt to master any one of the systems, but we will prepare food according to a few selected formulas.

Before beginning work, wipe off the table, put on a clean apron, and wash your hands and clean your nails thoroughly. You should be even more careful to guard against dust and bacteria than when canning, because, as a rule, the baby's milk is not to be sterilized.

FORMULA 1

Whole milk, 6 oz.

Water, 15 oz.

Milk-sugar, 2 tb.

This formula will make 21 ounces of food. It is to be divided into seven feedings. How many bottles will be needed? How many ounces of food must be put into each bottle?

Boil about a pint of water the first thing so that it will have time to cool before you use it. If the bottles and corks have not been sterilized according to directions for sterilizing jars on p. 298, do this at once. Collect all the materials and utensils needed. Rinse the utensils in boiling water.

Fill the measuring-glass with boiled and cooled water exactly to the 15-ounce mark. Pour it into the pitcher. Measure the sugar and put it into the pitcher. Stir till it is dissolved. Turn the milk bottle upside down and shake it well to mix in the cream. Wipe the mouth of the bottle before removing the cap. Fill measuring-glass with milk exactly to the 6-ounce mark. Pour the milk into the pitcher. Stir well.

Set bottles upright in rack. Place funnel in neck of the first bottle in the row. Pour exactly three ounces of food into the bottle. Place funnel in the next bottle. Pour in three ounces. Proceed till all the bottles are filled. Cork them and place next to ice.

FORMULA 2

Milk, 10 oz.

Barley water, 17 oz.

Lime-water, 1 oz.

Cane-sugar, 2 tb.

Prepare according to directions for preparing Formula 1, and divide into seven feedings. When plain water is used, it is best to dissolve the sugar (milk or cane) in it. In other cases it may be added after the liquid ingredients are in the pitcher. The order in which the ingredients are added does not matter so much as that they shall be well mixed and the sugar dissolved. Always wipe the mouth of the lime-water bottle before pouring out the lime-water.

FORMULA 3

Milk, 15 oz.

Barley water, 10 oz.

Water, 5 oz.

Lime-water, 1 oz.

Maltose, $\frac{3}{4}$ oz.¹

¹ Malt soup, malt food, dextri-maltose, or neutral maltose. If Freihofer's malt is used, add to every ounce 10 grains of potassium carbonate to neutralize its acidity.

Malt soup is liquid. If a solid maltose is used, put it with the water in a saucepan, let it come to a boil, and cool. Proceed as for Formulas 1 and 2. How many ounces will this formula make? It is to be divided into seven feedings, of $4\frac{1}{2}$ ounces each. How much will be left over? Divide this trifle between two or three of the bottles.

CHANGING THE PROPORTION OF FAT IN MILK

Increasing the proportion of fat.—The amount of fat in milk is indicated by calling it a 4 % milk, or a 5 or 6 % milk, according to the percentage of fat it contains. Most babies cannot digest milk containing more than 4 % of fat. If a baby can digest richer milk, it is well to give it to him. For some babies 7 % milk may be used. In this there is about twice as much fat as protein, the same proportion as in mother's milk. Few cows give 7 % milk. It may be obtained by adding cream to poorer milk, or by using the top part of bottled milk. Formulas calling for such milk are called *top-milk formulas*.

FORMULA 4

7 % milk, 7 oz.	Lime-water, 1 oz.
Milk sugar, $\frac{3}{4}$ oz.	Water, 12 oz.

This is to be divided into seven bottles, putting a scant three ounces into each bottle.

Remove with a cream dipper the upper 16 ounces of a quart bottle of ordinary (4 %) milk. Do not *pour* it off. Measure seven ounces of this top milk and proceed as in Formula 1.

To obtain 7 % milk from milk containing less than 4 % of fat, you will have to use less than half the bottle. To obtain it from rich Jersey milk you will have to use more than half the bottle. If a doctor orders top-milk formulas, he will see that you have milk of a known fat content and will tell you exactly how much top milk to remove.

The use of skim milk. Lowering the proportion of fat. — Skim milk may be used as the basis of modified milk, or it may be used instead of water to dilute whole milk, when the object is to reduce the fat without reducing the protein and salts. To obtain 4 % milk from 5 % multiply 32 by 5, divide by 4, and subtract 32. This gives us 8, the number of ounces of skimmed milk which must be added to a bottle of whole milk to make 4 % milk.

General rule for lowering the fat content. — Multiply the number of ounces in a quart, 32, by the figure representing the fat content. Divide the product by the figure representing the desired fat content, and subtract 32 from the quotient. The resulting figure will be the number of ounces of skimmed milk to be added to the richer whole milk to produce the milk desired.

If the milk comes in a pint bottle, what figure would you use instead of 32? Figure out the reduction of 1 pint of 5 % milk to 4 % milk. How many ounces of 4 % milk can you make out of 2 quart bottles of 5 % milk? How many out of 2 pint bottles? If the formula calls for 18 ounces of milk or less, will it be most economical to use quart or pint bottles? Why? An extra pitcher will be needed for mixing the skim milk and whole milk.

FORMULA 5

Milk (4 %), 16½ oz.	Malt sugar, 2 tb.
Barley jelly (thick barley gruel), 10½ oz.	Water (to boil sugar in), 3 oz.

Suppose you have only 5 % milk. To obtain 4 % milk, you must add 8 ounces of skimmed milk to a quart of whole milk, or 4 ounces of skimmed milk to a pint bottle of whole milk. To skim the milk, dip off all the cream with a cream-dipper. The milk should have stood in a cold place at least four hours, so that the cream line is distinct. Stir the skim milk and whole milk together in one pitcher. Measure 16½ ounces and put into the other pitcher. Proceed as with other formulas. Stir the food after filling each bottle, or the barley jelly may settle at the bottom of the pitcher, and the last bottle filled will contain more barley jelly than the others. Do this wherever thick gruel is used.

NOTE TO TEACHER. — For school-work it is not necessary to have actual 5 % milk. The method of obtaining 4 % milk from 5 % milk may be practiced with any milk, whatever its fat content.

PASTEURIZED MILK FOR BABIES

If you cannot be sure that the milk is from healthy cows and exceptionally clean, it should be pasteurized, boiled, or sterilized. What is the purpose of sterilization? of pasteurization? How would you pasteurize milk for family use? (See Home pasteurization, p. 97.) Milk pasteurized at 145° F. is about as nutritious and digestible for a baby as raw milk is, although there is reason to think that raw milk, if clean, has some advantages. Commercial pas-

teurization does not make milk safe for a baby. When his milk is to be pasteurized, this should be done after it has been modified and put into feeding-bottles.

The pasteurizer. — Several makes of pasteurizers can be bought. The essentials are a circular rack made to hold feeding-bottles, a kettle or pail large enough to hold the rack, and a thermometer. The rack must hold at least as many bottles as the baby has feedings in twenty-four hours.¹ With an improvised pasteurizer, a bath-towel or other thick cloth will be needed.

Directions for pasteurizing modified milk.² — Set the bottles in the rack to fill them. Plug them with sterilized, but not absorbent, cotton. Place the rack in the kettle. Insert a thermometer in the neck of one bottle. Pour cold water into the kettle till it reaches above the level of the milk. Heat the water slowly and watch the thermometer. When it registers 145° F., remove the bottles. Change the thermometer from the milk to the water. Pour cold water into the kettle until the thermometer again registers 145° F. Put the bottles back and cover them with a clean bath-towel or other heavy cloth. Let them stand covered at least twenty minutes, and not more than thirty. Cool the bottles quickly. This may be done by running cold water into the kettle. Take out the cotton plugs, one at a time, instantly replacing each by a sterilized cork. Pack the bottles in ice or set them close to ice in the refrigerator.

¹ In the absence of a rack, the bottles may stand on a tin pie-plate with a few holes punched in it. The plate is supported on blocks of wood.

² Adapted from Circular 197. Bureau of Animal Industry. U. S. Dept. of Agriculture.

How does the method of pasteurizing in feeding-bottles differ from that of pasteurizing in milk-bottles? Why not cool the bottles by putting them on ice at once?

Boiled milk may be ordered for a very young baby, or for a baby with disordered digestion. It is not best, as a rule, to give it to a well baby for long at a time. If the milk is suspected of containing dirt or disease germs, it should be boiled as a precaution. The best method is to put the bottles of food in the pasteurizer, let the water come to a boil, and boil for forty-five minutes. Another way is to boil the modified milk in a saucepan for* from one to two minutes, and pour at once into the feeding-bottles. Cool in running water, and place on ice. Use within twenty-four hours. How can you keep the bottles from breaking when the hot milk is poured into them?

TEMPORARY SUBSTITUTES FOR FRESH MILK

Sterilized milk. — If the milk must be kept for more than twenty-four hours, or kept without ice, as on a journey, all the spores in it must be killed as well as all the active microorganisms. (See Bacteria in milk, p. 97, and the Life history of bacteria, p. 295.) To sterilize milk, boil it in the feeding-bottles for fifteen minutes on three successive days. Keep them on ice between one sterilization and the next. If the bottles are corked in the ice-box, replace corks by cotton plugs during sterilization.

Sterilizing milk lessens its food value. A baby fed upon it for a long time is likely to become seriously ill.

Canned milk: condensed or evaporated. — There are

three kinds of canned milk. The first is made of unsweetened whole milk, the second of whole milk sweetened, the third of skim milk sweetened. Unsweetened condensed milk is sterilized. This alone makes it unfit for a baby's steady use. The sweetened kinds depend for their keeping qualities on the large amount of cane-sugar added to them. (What other food is sometimes preserved in this way?) Canned milk is a convenience when good fresh milk cannot be obtained. It cannot make good the place of fresh milk in the diet. As a baby-food it has many defects. It may not be made from clean milk. Most kinds contain too little fat, and, when diluted for use, too little mineral matter. Sweetened condensed milk contains too much sugar. Babies fed on it are often very fat, but they are not likely to grow up strong. Unsweetened condensed milk may be used for a short time when good fresh milk is not obtainable or does not agree with the baby.

Dried milks. — Several kinds of dried and powdered milks are on the market. Some are made from whole milk, some from skim milk. Certain of these may be prescribed for a sick baby, or used for a well one, as condensed milk may, in an emergency. So-called "malted milk" is a mixture of dried milk and malted grain.

Proprietary baby-foods (Mellin's and the like) are not substitutes for milk. They are cereal foods, with more or less of the starch changed to more soluble carbohydrates. For some babies one of these foods may be added, instead of gruel, to the milk. They are much more expensive than gruel, however.

Other foods sometimes prescribed for bottle-babies are beef-juice, white-of-egg, vegetable soup made according to a special formula, and orange-juice. Babies who have to be fed on sterilized milk must have fresh orange-juice. It is well to give orange-juice if there is any possibility that the milk you use has been pasteurized or heated at all, or if it is diluted more than one-third.

A baby under one year must not have ice-cream, candy, soda-water, and, of course, no tea, coffee, beer, or any alcoholic drink. Nor should he have any solid food, except, *after the ninth month*, a spoonful of soft-cooked egg occasionally, and a piece of zwieback or a hard Educator cracker to gnaw.

A baby needs water.—This should be boiled and cooled. It may be given to a little baby from a feeding-bottle. Later let him learn to take it from a spoon.

GENERAL INSTRUCTIONS ABOUT FEEDING THE BABY

1. Feed the baby regularly, and not too often. Until the baby is four or five months old, he should, in most cases, be fed six times during the day and once during the night. Convenient feeding hours are 7, 10, 1, 4, 7, and 10 o'clock, and 2 o'clock in the night. After the age of four or five months feed six times only; give nothing between 10 or 11 at night and 6 or 7 in the morning. It is usually not best to feed a bottle-baby quite so often as a nursing baby.

2. To warm the bottle, place it about ten minutes before feeding-time in a tall cup of warm water, so that the water comes up to the shoulder of the bottle. After five minutes or

so, shake it well, take out the cork, and put on a nipple. Let a few drops of milk fall on your wrist. It should feel a little warmer than your flesh. If cooler, warm it a little longer. If too hot, let it stand and test it again. *Never put the nipple in your mouth.* It is well to wrap the bottle in a thick cloth or slip it into a little woolen bag made to fit it, in order to keep the milk warm. If the last of it gets cold, the baby may refuse to take it.

3. The best way to give the bottle is to hold it while the baby takes it, tilting it just enough to keep the nipple full of milk. If no one has time to do this, prop the bottle up carefully so that the nipple will keep full till all the milk is gone. Otherwise the baby may swallow air. Take the bottle away as soon as he has taken all he will.

A well-nourished baby is plump. No baby should be thin. But fat alone is not proof of health. A baby may be too fat. The flesh should be firm. A healthy baby is happy. He does not cry much. He gains weight steadily. A bottle-fed baby cannot be expected to gain as fast as a nursing baby, but if he does not gain at all something is wrong. Have the best possible advice. Do not go by the way some other baby is fed. Each baby is a problem by himself.

BRIEF REFERENCE LIST

For further development of topics treated in this section see:—

COTTON: *Care of the Child.*

HOLT: *Care and feeding of children.*

KERLEY: *Nutrition of school children.* (Teachers College Record, March, 1905.)

KERLEY: *Short talks to young mothers.*

DENNETT: *The healthy baby.*

SCHERESCHEWSKY: *Infant mortality in relation to infant feeding.* In Hygiene laboratory bulletin 56 of the U. S. Public health and marine hospital service.

KASTLE AND ROBERTS. *The chemistry of milk.* (In the same.)

McCOLLOM: *Feeding of young children.* Journal of Home Economics, v. 13, p. 133, 1912.

WILEY: *Infant and invalid foods.*

PATTEE: *Practical dietetics with reference to diet in disease.*

See also references following section on Milk.

SECTION 2. FOOD FOR THE SICK

Importance of proper diet in cases of sickness. — Preparing and administering the patient's food is an important part of a nurse's work. Recovery, in many cases, depends more upon proper food than upon medicine. The doctor will tell you what to give the patient; but the more you know about food, cooking, and digestion, the more intelligently you will be able to carry out his orders.

Three kinds of diet. — Diets for the sick are classified as liquid, light, and convalescent. *Liquid diet* consists entirely of liquid food. In typhoid fever, and sometimes in other cases of severe illness, nothing but milk is given for a long time. But usually beef-juice or beef-tea, broths, gruels, and, in fevers, cooling drinks are included in liquid diet. Hot milk or cocoa, given at night, induces sleep; tea and coffee are usually forbidden at all times, as too stimulating. Wine or liquor should never be given unless prescribed by the physician.

Light diet is used in less severe illnesses, or when a patient

who has been very sick begins to improve. It includes everything belonging to liquid diet, and, in addition, soft-cooked eggs, soup, gelatin jellies, soft puddings, custards, fruit, and a little game, poultry, or tender meat.

Convalescent diet includes all ordinary dishes except those particularly difficult of digestion. The change from one diet to another should be made gradually. Below are given examples of each of these three kinds of diet.

LIQUID DIET FOR ONE DAY

8 A.M.	Hot milk, $\frac{3}{4}$ c.
10 A.M.	Chicken broth, $\frac{3}{4}$ c.
12 A.M.	Eggnog.
2 P.M.	Hot milk, $\frac{1}{2}$ c.
4 P.M.	Buttermilk, or Kumiss, a glassful.
6 P.M.	Chicken broth, $\frac{1}{4}$ c.
8 P.M.	Cocoa, $\frac{3}{4}$ c.

LIGHT DIET FOR ONE DAY

BREAKFAST

Poached egg on toast. Coffee.

LUNCH

Soft custard.

DINNER

Broiled mutton chop. Dry toast.

LUNCH

A glass of milk or buttermilk.

SUPPER

Milk toast. Cocoa.

OATMEAL GRUEL

Oatmeal, $\frac{1}{4}$ c.

Cold water, 1 qt.

Salt, 1 t.

Cook these together in a double boiler for two hours. Press through a strainer, dilute with milk or cream, reheat, and serve. *The well-beaten white of one egg* stirred into the gruel makes it more nutritious.

CORNMEAL GRUEL

(Adapted from Miss Farmer's *Boston Cooking School Cook-book*.)

Cornmeal, 2 tb.

Salt, 1 t.

Flour, 1 tb.

Cold water, about $\frac{1}{4}$ c.

Boiling water or hot milk, 3 c.

Mix meal, flour, and salt; stir into them enough cold milk or water to make a thin paste; and pour this into the hot milk or water. If water is used, cook one hour in a saucepan; if milk, three hours in a double boiler. Serve hot, diluted with milk or cream.

SHREDDED-WHEAT GRUEL

Shredded-wheat biscuit, 1.

Boiling water, 1 pt.

Salt, 1 t.

Milk, 1 c.

Cook biscuit, salt, and water together for twenty minutes, stirring occasionally. After adding the milk, strain.

EGG PREPARATIONS

(See Chapter III, Sec. 1.)

Raw eggs are often prescribed. Break the egg into a glass, and let the patient swallow it whole.

EGG GRUEL

(Adapted from Mrs. Lincoln's *Boston Cook-book*.)

Egg, 1.

Hot milk (not scalded), 1 c.

Sugar, 1 t.

Nutmeg or lemon juice to flavor.

While the milk heats, beat the yolk of the egg till thick and light colored, the white till stiff. Stir into the yolk the other ingredients in the following order: Sugar, milk, beaten white, flavoring. Serve hot in a glass placed on a plate covered with a doily.

EGGNOG

Eggs, 1.

Wine, 1 or 2 tb., or

Sugar, 2 t.

Brandy, 1 t., or

Lemon juice, 1½ tb.

Nutmeg.

Beat the egg till thoroughly foamy; stir in the other ingredients.

SHIRRED EGG

Break an egg into a buttered cup or egg shirrer; let this stand in a pan of hot water in the oven till the white jellies. Season and serve in the same dish placed on a plate.

MILK PREPARATIONS

(See Sec. 2 of Chapter III, and paragraphs relating to Yeast in Chapter IV, Sec. 4.)

Milk diet may be varied by giving the milk in various forms; *e.g.*, fermented, or as milk punch; if permitted, in milk jellies and ice-cream; and by serving it sometimes hot, sometimes cold, and sometimes flavored with coffee. When plain milk does not agree with the patient, a little lime-water or a few grains of salt is sometimes ordered to be put into it.

ALBUMINIZED MILK

Put the white of one egg and half a cupful of milk into a glass jar, cover tightly, and shake until well mixed.

PEPTONIZED MILK

Fairchild's peptonizing powder, 1 tubeful. Cold water, $\frac{1}{4}$ c.
Fresh cold milk, 1 pt.

Shake the water and powder together in a quart glass jar or bottle, add the milk, and shake again. Set the jar into warm water, and keep it as near 130° F. as you can for twenty minutes. Then put it at once on ice. Serve with grated nutmeg, sugar, or mineral water, as the patient may prefer or the doctor prescribe.

Fermented milk. — Among fermented milks in use are so-called buttermilks, fermented by a preparation of lactic acid bacteria¹; kephir, produced by a combination of alcoholic and lactic acid fermentation; and kumiss, fermented by yeast.

KUMISS

Milk, 1 qt. Lukewarm water, 1 tb.
Sugar, 1 tb. Hot water, 1 tb.
Yeast, $\frac{1}{8}$ cake.

Have ready bottles, cleaned, sterilized, and cooled. Scald the milk and cool till lukewarm. Boil the sugar with the hot water till dissolved. Mix the yeast with the lukewarm water. When the syrup is cool, stir it and the yeast

¹ A "pure culture," of the one kind of bacteria desired, unmixed with any other.

into the milk. Pour at once into bottles, filling them to within one and one-half inches of the top. Cork and shake well. Stand in a warm room ten hours. Lay them down in the ice-box for from three to five days. Slow fermentation produces the best kumiss, but if needed for use the day after making, the bottles may be allowed to stand in the room for six hours in summer, twelve in winter, and then laid in the ice-box for twelve hours. If ordinary bottles are used, tie the corks down.

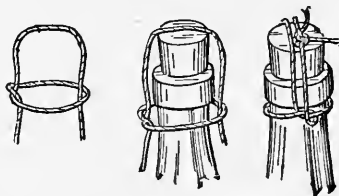

FIG. 17.—Method of tying corks into kumiss bottles.

IRISH MOSS JELLY

Irish moss, $\frac{1}{4}$ c.

Salt, f.g.

Milk, 2 c.

Sugar, to suit patient's taste.

After washing the moss, let it soak in the milk in a double boiler one hour; then cook until the milk steams, sweeten, and strain into moulds. When cold, turn out on a colored plate, and serve with cream and sugar. Vanilla may be used to flavor either jelly or cream, if the doctor approves.

GLUTEN WAFERS

(See Chap. IV, Sec. 2, Flour.)

Cream, $\frac{1}{2}$ c.

Gluten flour, enough to make a stiff dough.

Salt.

Mix cream and flour, roll out very thin, prick with a fork, and sprinkle lightly with salt. Bake the wafers till crisp and brown.

RAW BEEF SANDWICHES

(See p. 151.)

BROILED BEEF TENDERLOIN

Over a carefully broiled slice of tenderloin, squeeze, with a meat-press or lemon-squeezer, the juice of half a pound of beef-round. Season with salt, and with pepper and lemon juice, if the doctor approves. Use no butter.

CHOP BROILED IN PAPER

Lay the chop between slices of glazed writing paper. Trim these to within one inch of the chop, and fold their edges together, enclosing the chop. Broil over hot coals, turning often. The paper holds all the juices. When the chop is cooked, hold it over the dish it is to be served on and remove the paper. Season it and serve on toast.

CLAM BROTH (one cupful)

Large clams, 6 or 8.

Water, $\frac{1}{4}$ c.

Scrub the clams well with a brush and cold water.

Heat them with the one-fourth cupful of water in a covered saucepan till their shells open. Boil for one minute after this, and strain through cheese-cloth. Serve undiluted, or add a little hot water.

Clam broth can often be taken by a patient who can take no other food.

WINE JELLY

Granulated gelatin, $1\frac{1}{4}$ tb.Lemon juice, $1\frac{1}{2}$ tb.Cold water, $\frac{1}{4}$ c.Sugar, $\frac{1}{2}$ c.

Boiling water, 1 c.

Wine (sherry or Madeira), $\frac{1}{2}$ c.

Make like Lemon Jelly, recipe on p. 164.

CHAPTER XII

TEA, COFFEE, COCOA

Review Chap. I, Sec. 2, Water.

We drink to quench thirst. Thirst is the body's demand for water. Water is the best of beverages, other drinks satisfying thirst simply by means of the water they contain.

A *decoction* is extracted by boiling; an *infusion*, by treatment with boiling-hot water.

SECTION 1. TEA

A STUDY OF TEA

A. Put a teaspoonful of tea in each of two enamelled-ware saucepans, and pour upon one a cupful of boiling water; upon the other a cupful of water not quite boiling hot. Let them stand five minutes. Which is darker in color? Which stronger in taste? What action has the water had on the tea? Which is the best solvent of tea, boiling, or merely hot water? (Observe that in water below the boiling-point the leaves float.)

B. Pour off half the tea made with boiling water, and let the rest stand ten or fifteen minutes longer. Meanwhile, pour another cupful of boiling water upon a spoonful of fresh tea, and boil it five minutes. What is its color? taste? Add to this, to the tea standing on the leaves, and to the tea poured off, a few drops of *copper sulphate*. Does it act on all alike? At what temperature should water be for making tea? How long should it steep? Should it boil? Give your reasons.

C. Take out a few of the wet tea leaves and unroll them; find, if possible, an unbroken one; note its pointed shape and notched edges. Do you find other kinds of leaves? Any sticks or other foreign matter? If the tea is Young Hyson, Pekoe, or other high-grade tea, look for buds.

Composition of tea. — Tea contains theine, a stimulant; pleasant-flavored oils; and tannin, a bitter substance, similar to the tannins used in tanning leather and in making ink. Tannin interferes with digestion.

Effect of hot water on tea. — Boiling water poured over tea dissolves its theine and flavoring matter, making a delicate, refreshing drink; water below the boiling-point draws these out imperfectly, and, in consequence, the tea is insipid. Boiling the tea, or letting it stand long on the leaves, extracts the tannin. Tea made by adding fresh water to old leaves in a pot that stands on the stove all day contains enough tannin to make it highly injurious.

How to have good tea. — 1. Keep the tea in a closely covered glass jar or tin canister; if exposed to the air it loses flavor. 2. Use a china, or silver, or earthen teapot; never a tin one. 3. Have the teapot *hot* and the water *boiling* at the moment the tea is made. 4. Steep it not over five minutes; *never let it boil.*

DIRECTIONS FOR MAKING TEA

Allow from one to three teaspoonfuls of tea to two cupfuls of water, using less of close-rolled than of coarse, loose teas. When the water boils, scald the pot, put in the tea, and pour in the boiling water, and let it stand covered from three to five minutes. Unless all the tea is to be poured immediately, a tea-ball or other device should be used so that leaves can be removed from the infusion.¹ Serve with sugar, and

¹ Color does not show the strength of an infusion, the finest teas giving a light color even after long steeping; it is tannin that makes tea dark.

milk or cream, or with sugar and thin slices of lemon. For weakening it, use water as nearly as possible boiling hot.

Iced tea, made weak, is a wholesome summer drink. Serve it strained, with lemon and powdered sugar.

How tea is grown and made ready for market. — Tea consists of the dried leaves of an evergreen shrub native to China. China, Japan, and India are the chief tea-growing countries. A little tea is now raised in the United States. Tea-plants naturally grow tall, but in a tea-garden they are trimmed to keep them bushy. Only buds and young leaves are picked. The leaves tend to ferment. In making green tea, fermentation is prevented by heating the freshly picked leaves. They are then rolled, “fired” (that is, dried by artificial heat), and graded by sifting. For black tea, the leaves are wilted, rolled, and allowed to ferment before they are fired. Fermentation darkens the tea and lessens the amount of tannin.

Kinds and qualities of teas. — Teas are classed according to the country they come from, the method of curing, and the size and quality of the leaf.

In China and Japan old-time methods are employed, involving much handling of the tea. In India, the use of machinery makes the process cleanly. “Japan” tea is green, India and Ceylon teas black and strong-flavored. Oolong is less fermented than other black teas. “English Breakfast tea” is a trade name for a blend (mixture) of black teas. Pekoe is a name applied to leaves from the young shoot, Souchong to the next larger leaves. Flowery

Pekoe and Orange Pekoe are fine grades of India teas. Hyson indicates that the tea was picked in the spring.

SECTION 2. COFFEE

A study of coffee. — A. Compare roasted with unroasted coffee beans, observing differences in color, odor, and taste. Brown a few unroasted beans on a pan or shovel over the fire, and compare them with the roasted ones. What changes does roasting produce in coffee?

B. Boil together for ten minutes one rounded tablespoonful of coffee and one cupful of water; compare taste with that of coffee made by either of the methods given below. In what respect is long-boiled coffee like boiled tea?

Coffee — on the plantation and in the market. — The coffee “bean,” or berry, is the seed of the red cherrylike fruit of a tropical evergreen. Each fruit usually contains two berries. When the fruit begins to shrivel, it is shaken to the ground and dried until the seeds can be easily separated from the pulp. The seeds are run between wooden rollers to crack off the husk enclosing them, after which they are roasted in a revolving cylinder. Great care is taken to have the degree of heat that will best develop their characteristic flavor and odor, or *aroma*.

The berry is freed from pulp and papery skin by different methods in different countries. The color of the raw berry ranges through various shades of yellow and green. Coffee is shipped raw and roasted in the country which imports it. Roasting turns it brown. A long or “high” roast produces a dark coffee with a strong flavor and develops its characteristic flavor and odor, or *aroma*.

Coffee is believed to have originated in Abyssinia. It

now grows in South and Central America, Mexico, the East and the West Indies, and some other places. Most of our coffee comes from Brazil. Java and Mocha (an Arabian port) have always exported fine coffees, but not in sufficient quantities to meet the demand for them. These names are now applied by grocers to the better grade coffees, whatever their source. Ground coffee is sometimes adulterated with ground cereals, chicory, or other material.

Test for adulteration in coffee. — Pour on to about a tablespoonful of ground coffee a cupful of cold water. If nearly all the coffee floats and colors the water very slowly, it is pure. If part of the "coffee" sinks to the bottom or stains the water quickly, chicory or some other adulterant is present.

The beverages tea and coffee have no food value beyond that of the sugar or sugar and cream added to them. Their stimulating properties are due to a substance called theine in tea and caffeine in coffee. The tannin of coffee is in a different form from that of tea. Coffee may be boiled, but if allowed to boil or to stand on the grounds for more than a few minutes, tannin will be extracted and the coffee will taste bitter. Tea and coffee relieve the *feeling* of fatigue and enable a person to work for a short time harder than his natural strength would permit. This effect is more marked upon some people than upon others. To some persons they are injurious. They serve best if reserved for emergencies, times of special fatigue or strain. No person of normal constitution who is neither undernourished nor overworked needs to depend habitually on any stimulant. Children

should never taste tea or coffee. Young people up to twenty years of age or more are better off without them. The evil effect of tea and coffee may appear in later life if not immediately. A special coffee from which practically all the caffeine has been removed is sold unground.

Substitutes for coffee made of roasted grains are palatable, and as a rule wholesome for grown people and children.

How to have good coffee. — 1. Buy freshly roasted, unground coffee, and grind it at home as needed; or buy it freshly ground every two or three days. The longer it is kept after roasting, particularly if ground, the more of its aroma does it lose. 2. Keep in an air-tight can or jar. 3. Never make coffee in a tin pot. Scour the pot, not omitting the spout, after each using. 4. Either filter the coffee, or boil it not longer than three minutes. 5. Have coffee powdered for filtering, finely ground for boiling. 6. Serve with cream, or with hot, but not scalded, milk.

BOILED COFFEE

Ground coffee, $\frac{1}{2}$ c.

Water, 3 or $3\frac{1}{2}$ c.

One-fourth the white of an egg, or one egg-shell with the white that clings to it.

(See directions for clearing soup stock, p. 167.)

Mix the coffee, the white of egg, or the broken shell, and about one cup of the water (cold). Pour on the rest of the water, allow it to heat slowly to the boiling-point. Let it boil one minute. Remove the pot from the fire, pour in a few spoonfuls of cold water, and let the coffee stand about five minutes, during which the grounds will settle.

Another way. — After mixing coffee, egg, and cold water, pour on the rest of the water boiling hot, and let the coffee boil three minutes. Settle in the same way.

To make one cup of coffee, use two rounded tablespoonfuls of coffee and one cupful of water. With care, a small quantity of coffee can be cleared without egg, by pouring in a little cold water as directed above.

FILTERED COFFEE

Powdered coffee, $\frac{1}{2}$ c.

Boiling water, 3 c.

Use a coffee pot with bag or filter.

Measure the water before boiling it. Put the coffee into the bag or filter. Pour the water slowly upon it directly from the kettle. Keep it hot, till the water poured in has filtered through. Pour part of it out, and turn it through the filter again. This makes **black coffee**, suitable for serving in small cups after dinner. Make breakfast coffee less strong.

SECTION 3. COCOA AND CHOCOLATE¹

The cocoa tree ; preparation of the bean for market. — All **cocoa** and **chocolate** preparations (*Cacao theobroma*) are products of the seeds of the cocoa-tree, a native of the tropic parts of America. These seeds, called cocoa beans, are about the size of almonds. They lie encased in shells, sur-

¹ A confusing use of terms has resulted from retaining both the name chocolate, by which plant and beverage were known to the natives of Mexico, and cocoa, a changed form of cacao, the name given to them by the Spanish. The cocoa tree belongs to a different family from the cocconut palm.

rounded by fibrous pulp, in a brownish yellow pod which grows to be from six to twelve inches long. The pods as they ripen are cut off with knives fastened on poles, and are left on the ground for twenty-four hours to dry. The beans and pulp are then removed and allowed to ferment for several days. Fermentation loosens the pulp and the skin of the bean and prevents germination (sprouting). It also darkens the beans and mellows their flavor. After they have been washed and thoroughly dried, they are packed in sacks for shipping.

Manufacture of cocoas and chocolates. — At the factory the beans are cleaned, sorted, and roasted. The shells are cracked off and the beans crushed into the irregular bits we know as *cocoa nibs* or *cracked cocoa*. The papery husks are winnowed out. These are sold as *cocoa shells*. If the nibs are to be made into either *chocolate* or *powdered cocoa*, they are ground between slightly warmed stones. They contain so much fat that the warmth and grinding reduce them to paste (p. 214). If this paste or “cocoa-mass” is to be made into powdered cocoa, more than half the fat is extracted. The dry substance left is sifted, ground, and put up in tins. If chocolate is to be made, the fat is left in. Sometimes more is added. The paste is made smooth and fine by passing it between pairs of rollers. It may then be moulded. This makes *plain chocolate*. For *sweet chocolate*, sugar, vanilla, and sometimes spice, are added before moulding. For *milk chocolate*, milk, either condensed or dried and powdered, is added besides sugar and vanilla. Dutch powdered cocoas are treated with alkalies. This process is not altogether

desirable. Cheap chocolate may be adulterated with starch and cocoa husks. The extracted fat, called cocoa-butter, is valuable.

Composition and food value of cocoa and chocolate. — Chocolate is a food. An average sample of roasted cocoa contains about 9% of starch, 15% of nitrogenous matter, and 50% of fat. (Observe fat-globules on chocolate that has been standing.) It contains a very little caffeine and more theobromine, a substance similar to caffeine, also a tannin-like substance. It is somewhat stimulating, but it does not interfere with digestion as tea and coffee do. Milk chocolate and sweet chocolate are compact foods for trampers, explorers, and soldiers. The sugar in it increases its food value. Not enough cocoa is used in making a beverage, however, to give it any appreciable food value, beyond that of the milk and sugar in it. Generally speaking, it is wholesome, even for children and the sick. Chocolate makes a more nutritious beverage, but is too rich in fat for constant use. Cocoa shells makes a wholesome cheap drink.

Cocoa is insoluble, but when boiled with water the starch thickens sufficiently to keep the other solid particles suspended. So-called "soluble cocoas" are so prepared that they remain in suspension longer than other kinds.

COCOA MADE FROM CRACKED COCOA

Cracked cocoa (or cocoa and cocoa shells), $\frac{1}{2}$ c.

Boiling water, 3 pt.

Boil cocoa and water together for two hours or more; strain and serve with milk and sugar. Since cocoa made in

this way improves by cooking, do not throw away what is left in the pot, but add each day more water and a little fresh cocoa, and boil again. Once a week empty and clean the pot.

BREAKFAST COCOA

Scalded milk, 1 pt.	Prepared cocoa, 3 tb.
Boiling water, 1 pt.	Sugar, 3 tb.

Mix the cocoa and sugar in a saucepan ; stir in the water gradually, and boil five minutes ; add the milk and cook five minutes longer, or until smooth and free from any raw taste. Beat well with a Dover egg-beater to prevent albuminous skin from forming.

To make cocoa which will not settle on standing, mix thoroughly half a tablespoonful of cornstarch with the cocoa and sugar. This makes a smooth, creamy beverage.

CHOCOLATE

Chocolate, 2 squares.	Boiling water, 1 c.
Sugar, 4 tb.	Hot milk, 3 c.

Cut the chocolate into bits. Melt it in a saucepan set over hot water. Add the sugar and water, stirring till smooth. Pour into this part of the milk, then pour the chocolate back into the rest of the milk, and stir till it comes to the boiling-point. Beat till frothy with an egg-whisk or a Dover beater.

For a luncheon or for afternoon tea serve in tall cups. It is customary to put a spoonful of whipped cream (101) on the top of each cup. Why would it be more sensible to add cream to cocoa, not to chocolate?

BRIEF REFERENCE LIST

For further development of topics treated in this section see : —

WARD : *Grocers' encyclopedia*.

SHERMAN : *Food products*. Pp. 465, 466.

HUTCHISON : *Food and the principles of dietetics*. Ch. 18, p. 332,
Effects of tea, coffee, and cocoa.

RICHARDS : *Tonics and stimulants*. (Health Educational League. Book-
let no. 11.)

OLSEN : *Pure food*. Pp. 106-116.

WHYMPER : *Cocoa and chocolate*.

CHAPTER XIII

THE SERVING OF FOOD

SECTION 1. TABLE SERVICE

Food tastes better for being nicely served. A tired or delicate person may be unable to eat food placed on smeary dishes set irregularly on a crumpled, spotted cloth, when she would eat heartily of the same food neatly arranged. Every meal can be made appetizing even though it consists of a single dish eaten from a kitchen table. A well-cooked dish may be spoiled by bad serving, as when chops are put in cold plates, salads on warm ones; when an omelet is allowed to stand until it falls, or a sauce is not passed till the food it belongs with is cold or has been partly eaten.

The suggestions given below assume conditions desirable, but not all of them necessary, for good serving. If your home lacks some of these, do your best with what you have, remembering that the most important thing, next to having wholesome food, is to have the meal a pleasant, cheerful occasion for all the family.

If your family cook and eat in the same room, make it as orderly as possible before calling them to the table. It is well to have a screen to hide the stove, sink, and cooking-table at meal-times.

Importance of regular meals. — Have meals served regularly. Do not habitually let members of the family take a bit of food or a cup of tea whenever they happen to come in. This is not only bad for health, but destructive of home life. If the family cannot all meet at breakfast and at the noon meal, be the more particular to have the third meal nicely set out and to have all sit down to it together.

Take sufficient time for meals. Business men, working-people, school-children, and college students break down in health from eating hastily.

The dining-room should be so furnished that it can easily be kept clean. The floor should be polished or stained and a rug, not a tacked-down carpet, should be used. Wooden, cane-seated, or leather-cushioned chairs are suitable. Round tables are pretty. If a square-cornered one is used, it should not be less than four feet broad. Quaint or beautiful china and glassware adorn a dining-room, but dishes for use must be kept out of the dust.

If the dining-room is used as a living-room also, see that it is put in order before each meal and that the table is cleared and properly covered afterward. If used only as a dining-room, the table may, to save trouble, remain partially set.

Fresh air whets the appetite. Always open the windows for a few minutes before each meal. In southern California people often eat on a porch. This may be done anywhere in mild weather, if there is a porch convenient to the kitchen. It should be screened to keep out flies.

HOW TO LAY THE TABLE

Table linen. — First lay a “silence-cloth” (felt or thick canton flannel or a quilted pad) to protect the wood and make the table-cloth look and wear better. Lay the table-cloth with its middle crease straight down the middle of the table. See that the ends hang evenly. Doilies and a centre-piece, or strips of crash or of figured Japanese toweling are desirable for breakfast or lunch. With these asbestos mats in linen cases or knitted mats must be used under hot dishes. Under some conditions the sensible housekeeper will use white table oilcloth. If the table is otherwise well set, it will look well. Wash it off after each meal.

Table decorations. — Fruit or flowers always look well in the centre of the table. Nothing else should ever be placed there. If a lamp must be on the table, have it at one side, shaded. If candlesticks are used, place them symmetrically at equal distances from the centre. Four candles should stand at the four corners of an imaginary square. For entertaining formally, more decoration is allowable. But even then, avoid elaborate and showy arrangements. Heavy plain linen, sprays of smilax, holly, or whatever appropriate floral decoration the hostess can afford, produce a better effect than the lace, ribbon, favors, and general “fussiness” sometimes seen.

If meat is to be carved on the table, spread a large napkin or a carving-cloth at the carver's place. If a hot drink is to be poured by the hostess,¹ spread a tray-cloth (or a napkin) at

¹ For brevity, the master and mistress of the house will be called the host and hostess.



PLATE XVI.

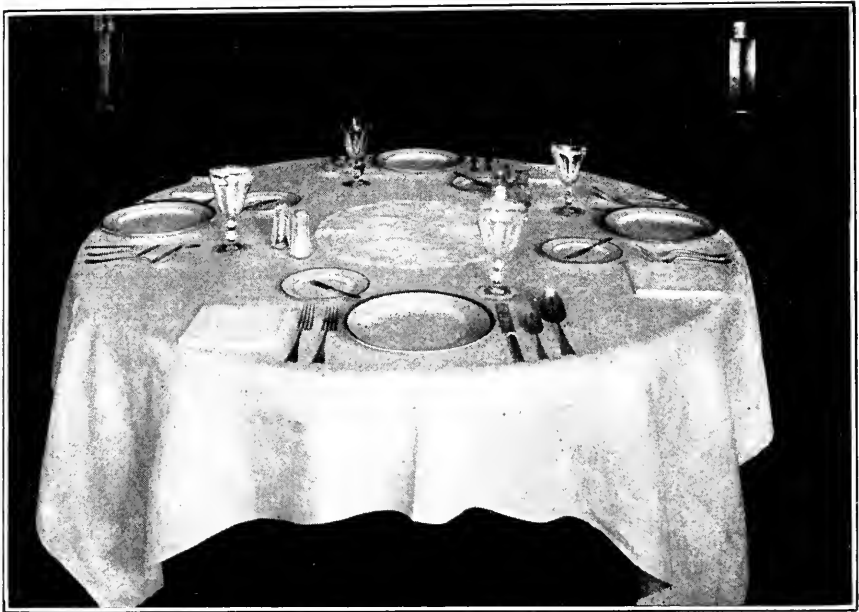

TABLE SET FOR DINNER.



SALAD PLATES, DESSERT DISHES, AND OTHER THINGS TO BE USED IN THE COURSE OF THE DINNER, ARRANGED ON SIDEBOARD OR SERVING-TABLE.

her place. If doilies are used under small dishes, arrange them symmetrically.

What goes at each place. — At each place lay a knife with its sharp edge toward the right. At the right of the knife lay, if needed, a soup spoon or a cereal spoon, the hollow of the bowl upward, and teaspoons, as many as will be needed. At the left of the plate lay a fork (or two, or three, according to the number of courses to be eaten with forks), the tines pointing upward; at the left of the fork a napkin. Put the tumbler, right side up, at the right and the butter plate or the bread-and-butter plate at the left. If butter spreaders are used, place them as shown in the diagram. A good rule is to place the tumbler a little to the right of the point of the knife, the butter plate a little to the left of the point of the fork. If individual salts and peppers are used, set them in front of each plate.

If tea or coffee is poured on the table, arrange in front of the hostess cream-pitcher, sugar-bowl, waste-bowl, and cups and saucers (each cup upright in its saucer if there is room). Tiles (or small plates) should be placed for coffee or tea pot and hot-water pot.

If the family serve themselves wholly or in part, lay convenient to each person who is to serve, the spoons or other implements he will need. Hot plates may be piled at the left of the person who serves the principal dish. Extra dishes, spoons, etc. should be arranged upon the side-board or upon a side-table covered with white linen. If a maid waits she may bring carving-tools, spoons, etc. when she

brings the dishes. Mats or tiles should be provided to protect table and side-board from hot dishes.

Other preparations for the meal. — Have butter cut in a block or made into balls ready in a cool place. Slice bread (with loaf on its side so that straight bottom edge is from you, to guide the eye) and keep it where it will not dry. Put these and the drinking-water on the table the last thing, placing them near the corners.

When everything needed for the meal is at hand and space is clear in pantry or kitchen to set dishes as they are removed from the table, announce the meal. In families living simply, a bell may be rung; where there is a waitress, she goes to the room where the hostess is and says quietly, "Dinner (or breakfast, or lunch) is served." Even where only one maid is kept, she should do this when guests have been invited to the meal.

In laying knives and forks for several courses arrange them in the order in which they are to be used, the first to be taken up being farthest from the plate. Oyster forks belong at the right hand.

Fresh napkins (not in rings) may be laid on the plates, with a corner towards the centre of the table. If they bear an initial or monogram see that it is right side up. Never fold napkins in fancy shapes. A roll, or bread cut thick to be eaten with soup, may be laid either between the folds of the napkin or at the left of the forks.

NOTE. — Table-laying gives you a chance to apply what you have learned in school about the meaning of the terms "parallel," "opposite," "at right angles," and the like. Places on opposite sides of the table

should be laid *exactly* opposite one another, the knife at one place being in the same straight line with the fork at the other. If you can measure by your eye in drawing you can lay a place exactly in the middle of one side of the table and can have every tumbler in the same relative position to the plate near which it stands. Should you fortunately have a choice of table-ware, use care in selecting and arranging the pieces for a meal, just as you would in making an original design.

Finger-bowls may be used after a fruit-course at breakfast and after dessert. Fill them one-third full of water at room-temperature, and set them on small plates on which doilies have been laid. At dessert-time place one before each guest. The guest will remove bowl and doily, leaving the plate for dessert. Sometimes a spoon and a fork are laid on the plate, to left and right of the bowl. The guest also removes these. If fruit is at each place when the guests come to breakfast, the finger-bowl, with or without a plate and doily, may be placed in front and to the left of each place.

NOTE TO TEACHER. — Ways of serving meals vary with conditions and change with time. Use a *recent* hand-book as a guide in this matter.

GENERAL RULES FOR WAITING ON TABLE

Whether a daughter of the house or a waitress waits on the table, these rules hold good.

Prepare for the meal so carefully and during it watch so attentively that nothing will have to be asked for. Fill glasses to within three-fourths of an inch from the top as soon as people are seated and keep them filled. Offer bread, butter, or a relish (as celery, pickles, jelly) at any time to any one who has eaten the portion he had.

How to pass food. — Carry plates and dishes on a small round or oval tray covered with a doily. When waiting to take a plate or cup from the person filling it, stand at the left.

It is proper to serve the hostess first, so that guests not quite sure what to do may follow her example. Serve the others in order, but do not serve the same person first all the time. *Offer at the left* a dish that may be accepted or refused, holding it low enough for the guest to help himself easily. *Place from the right* a plate with food upon it or anything about which no choice is to be made, except when an extra plate, for asparagus, for example, is used. *Place* this at the person's left before offering the asparagus. As soon as possible after the main dish of a course has been served pass whatever vegetables, sauce, or other things are to be eaten with it.

Clearing the table. — Remove everything pertaining to one course before serving the next, taking first food, second, soiled dishes, third, clean dishes. Relishes may be left throughout the meal until the dessert. Remove soiled plates, from the right, one at a time, if you can take time, but at an informal meal, you may pile them on the tray, laying knives and forks on the tray beside them. If bread has been laid on the table to be eaten with soup, remove the fragments on a plate after taking away the soup-plates. Before bringing dessert remove crumbs with scraper and crumb-tray or napkin and plate.

Work noiselessly, avoiding rattling of dishes or silver.

GENERAL RULES FOR DISHING UP

1. Have serving-dishes and plates for hot food *hot*, for cold food *cold*. To heat a dish quickly, dip it into hot water.¹

2. Use dishes suitable in size and shape for the food they are to contain. Use covered dishes whenever possible except for food desired crisp or dry (boiled potatoes, griddle-cakes, bacon). Use a shallow flat-rimmed platter for meat to be carved, and deeper one for fricassee or stew.

3. Baking-dishes hot from the oven must be set on plates to protect cloth and table. Pin around baking-dishes of coarse ware a napkin folded diagonally into a band broad enough to conceal the dish.

4. Serve croquettes, boiled corn, and baked potatoes, on a napkin.

5. Make each dish as attractive as you can. A simple garnish makes a plain dish seem nicer, and takes little time. Do not garnish too lavishly; a few sprigs of parsley are prettier than a border.

BRIEF REFERENCE LIST

For further development of topics treated in this section see:—

EARLE: *Home life in colonial days*. Ch. 4, The serving of meals.

VAN DE WATER: *From kitchen to garret*. Ch. 2, The dining-room.

BARROWS: *Principles of cookery*. P. 18, Directions for waitresses.

SPRINGSTEED: *The expert waitress*. For servants.

HILL: *Practical cooking and serving*. (See ch. 6, Hospitality and entertaining, for instructions for formal serving.)

HILL: *Up-to-date waitress*. (For laundering of table-linen, see p. 134.)

¹ The use of casserole-dishes and other attractive dishes in which the food may be both cooked and served saves work for the housekeeper.

SECTION 2. PREPARING MEALS

A BREAKFAST

Menu

Grape-fruit.

Oatmeal.

Cream or milk.

Soft-cooked eggs. Bacon. Whole-wheat muffins.

Coffee.

Allow one hour after the fire is well started to prepare this breakfast.

For recipes and directions for preparing oatmeal, see pp. 74 and 79, for grape-fruit, p. 232, coffee, p. 342, eggs, p. 88, bacon, p. 218, whole-wheat muffins, p. 113.

SUGGESTIONS FOR ORDER OF WORK

1. Set the tea-kettle filled with fresh water where it will heat quickly and the double boiler containing the oatmeal, cooked the day before, where the contents will cook slowly or merely keep hot as may be required.

2. Lay the table. (See p. 350.)

3. Grease muffin-pans.

Mix the muffins. (How long are they to bake? How long will it take you to mix them? How long then before breakfast time should you begin them?)

4. Prepare grape-fruit (if it has not been done before).

5. Cut the butter. Put milk and cream in pitchers, and set them in ice-box. (It is best to have one pitcher of cream for the coffee and one for the cereal.)

6. Grind the coffee (if it is not already ground). Measure it. Have coffee-pot ready.

7. Put dishes to warm; platter for bacon, covered dish for cereal (unless it is to be served from the kitchen), plate for muffins, breakfast-plates, cereal dishes, and egg-cups.

8. Put eggs to cook (and remember to take them out at the right time).

9. Cook bacon. If it can all be cooked at once, it will take about eight minutes.

10. Ten minutes before breakfast time, make the coffee. If hot milk is to be served with it, heat this now.

11. Set butter, cream, cold milk, and grape-fruit on the table. Fill glasses.

12. Announce the breakfast.

A DINNER

Menu

Tomato soup.

Roasted leg of lamb with mint sauce. Green peas.

Boiled potatoes with parsley.

Lettuce with French dressing. Cheesed crackers.

Caramel custards.

Coffee.

Allow two hours to prepare this dinner, if custard has been made beforehand. If places for more than four must be set, or if extra china and linen must be taken out, begin earlier and partly lay the table before putting the meat in the oven.

For recipes and directions for Tomato Soup, see p. 256, for Boiled Potatoes, p. 59, for Lettuce with French Dressing, pp. 259-261, for Cheesed Crackers, p. 102, for Caramel Custard, p. 284, and for Coffee (filtered), p. 343.

Pour just enough melted butter over the potatoes to coat them, and sprinkle *lightly* with finely cut parsley.

ORDER OF WORK

1. Wipe the meat and put it in the roasting-pan. One hour and a half before the dinner-hour, put it in the oven. Prepare mint and sugar for mint sauce, if not already done.

2. Shell peas, and wash lettuce.

3. Lay table; finish mint sauce; make ready the bread, mint sauce, and fruit.

4. Start soup (about forty-five minutes before dinner time).

5. Put peas to cook (allowing time according to their age).

Directions for roasting lamb. — Follow directions for roasting beef, basting about once in fifteen minutes. Put a little water in the pan if there is not melted fat enough to baste with.

MINT SAUCE

Finely cut mint leaves, $\frac{1}{4}$ c.

Granulated sugar, $\frac{1}{4}$ c.

Vinegar, $\frac{1}{2}$ c.

Mix the sugar and mint and let them stand for several hours if possible. Add the vinegar cold about an hour before serving.

6. Prepare cheesed crackers.

7. Dry lettuce and arrange in salad bowl. Leave in a cool place. Make French dressing.

8. Take up meat when done, and keep hot.

9. In the order given, finish making soup, dish and dress potatoes, dish peas, fill glasses.

10. Announce dinner.

A LUNCHEON

Scalloped meat (or fish).	Baking-powder biscuit.
	Celery.
Baked apples and cream.	Gingerbread.
	Cocoa.

Find recipes and directions for making the dishes for this luncheon. Think out and write down directions and an "order of work" for preparing this luncheon. After trying these plans, see if you can improve on them. With the aid of Chapter V write out other menus and plan how to prepare them.

BRIEF REFERENCE LIST

For further development of topics treated in this section see:—

BEVIER AND VAN METER: *Selection and preparation of food.*

CHILD: *The efficient kitchen.*

LINCOLN AND BARROWS: *Home science cook-book.*

CHAPTER XIV

LAUNDERING

NOTE TO TEACHER. — This chapter gives an outline of such laundry-work as may be taught in two or three lessons, incident to the work in cookery. It may provide a review of what the pupils have learned about water (Chap. I, Sec. 2), cleaning, soaps, alkalies, disinfection (Chap. I, Sec. 3), and starch (Chap. II, Sec. 2). Dish-pans with small washboards may be used for tubs, and a demonstration lesson given in ironing, if the equipment is not sufficient for practice work.

We depend chiefly upon soap and water to make soiled clothing clean. Sunlight and air are desirable aids. Chemicals may be needed: alkalies, borax, ammonia, and washing soda, to remove dirt, or soften hard water; either acid or other chemicals for removing stains. Heat, friction, and pressure may also be employed.

A good white soap is best for laundry use. Yellow soap contains much *resin*, which makes the clothes yellow and is hard to rinse out. A little resin helps poor soap to make suds, but in a large quantity it is an adulterant. Borax soap is good to use with hard water. Naphtha soap is good to use with cold or lukewarm water. Hot water drives off the naphtha.

We blue white clothes to overcome the yellowing effect of wearing and washing. Bluing is not meant to hide carelessness in washing and rinsing. We starch certain pieces to fill spaces between the threads, to stiffen them, and to

enable them to be finished smoothly with the iron. We iron to remove wrinkles, and to give to the fabric the smooth finish which makes it look better and keep clean longer.

Not all the ironing commonly done is necessary. Stockings, soft underwear, and Turkish towels do not need ironing. In hot weather, or when the ironing must be done by a woman burdened with other work, towels and even bed-linen may be used unironed.

ORDER OF WORK

Sorting and soaking. — Wash colored clothes separately from white ones, table-linen and dish-towels separately from other pieces. Wash woollens by themselves in lukewarm suds and rinse in lukewarm water.

Soaking saves rubbing. If clothes are to be soaked, put them into enough soapy warm water to cover them.

Washing. — The clothes may be rubbed out once in the water they have been soaked in, but they must be washed once besides in clean suds.

Spread one piece at a time on the washboard, soap it, and rub it on the board, dipping it now and then. Look for the most soiled places, and rub them hardest. Rub delicate fabrics and trimmings between the hands, not on the board.

Washing-machines. — Rubbing clothes on a board tires the worker and wears the clothes. A washing-machine saves time, strength, and fabrics. There are several kinds. They may be run by hand, water-power, or electricity. A good hand-washer consists of a metal cone with a straight

handle. When pressed down, it forces suds through the clothes, and when raised, sucks it back. With its aid, large, heavy pieces may be washed quickly.

Wringing. — Wring out and drop into rinsing water or into the boiler. Watch some one who knows the right twist, in order to learn how to wring by hand. Hand-wringing tends to wrench the fabric. For anything more than a few small pieces, a wringer is a necessity.

Boiling. — Boiling with soap cleanses and sterilizes clothes. It is especially important for underwear and much soiled pieces of any kind. It is not always necessary for other pieces if they can be dried in the sun. Colored pieces must not be boiled. Cut the soap into small pieces and be sure it is dissolved before putting in the clothes. It is best to use a soap solution, which can be kept on hand, and added to the water in the boiler. To make this, dissolve one pound of cut-up soap or "soap-chips" in one gallon of water. It will jelly when cold.

Clothes to be boiled are put into the boiler after being wrung from the wash-water. Boil three to ten minutes according to how soiled the clothes are. Stir with a clothes stick to let steam escape. Remove with the stick, and drop into rinsing-water.

Rinsing. — Clothes should be rinsed at least twice. If you lack a plentiful supply of water, or if water must be carried, save on the wash-water rather than on the rinsing-water.

Bluing. — Bluing goes in the last rinse-water. The safest bluing is the kind that comes in balls or squares. Tie it in a

woollen or cotton flannel cloth, and squeeze it into a bowl of hot water. Add this to the rinse-water until it shows a light sky-blue when taken up in the hand. As this kind of bluing settles, the water must be stirred with the hand frequently, and clothes must not lie in it, but be dipped and wrung out at once.¹

Starching. — Laundry starch is commonly corn-starch. Wheat-starch is better. Rice-starch is used for lace and very fine fabrics. To make starch for medium fabrics, allow two tablespoonfuls of starch to one quart of boiling water. (One teaspoonful of borax improves the starch.) Mix the starch with enough cold water to form a cream. Add the boiling water and boil till clear. Strain and cool till the hand can be borne in it. If clothing is liked rather stiff, use two and a half to three tablespoonfuls of starch; for shirt bosoms, five. For delicate waists and underwear, use only one. Dipping the damp clothes in the starch thins it, so that fairly thick starch may do for things to be lightly starched, if they are dipped last. Thick close fabrics should be dipped in thin starch.

Dry clothes in the air if possible. Sunlight whitens and helps to sterilize them.

Sprinkle clothes several hours before they are to be ironed, roll up tight. A clean whisk-broom makes a good sprinkler.

¹ Some people prefer liquid bluing. But all liquid bluing contains iron, which with soap forms rust. This makes little rust-spots on clothing, which many people think come from the board or the wringer. If you use liquid blue, rinse the clothes very thoroughly to get all the soap out before you blue them. Even then a rust-spot may appear the next time they are put into soapy water.

Ironing. — Irons must be kept clean and smooth. If rough, rub them on salt sprinkled on a paper. Experience is needed to enable one to know how hot an iron should be for a given fabric. Spread out the piece. Iron with the threads; with the long thread (warp) as much as possible, keeping the fabric stretched and flat with the left hand. One must learn how to iron by watching a good ironer. If you have much ironing to do, use a high chair or stool while ironing simple pieces, and save yourself fatigue.

An electric iron is well worth what it costs. Remember that it grows hotter, not cooler, and may scorch.

Removing stains. — To remove fresh fruit or coffee stains, stretch the fabric over a bowl, and pour boiling water through the stain. Cocoa and chocolate stains should be washed in cold water with soap or borax before being put into hot water. Peach stains require Javelle water.

SPECIAL INSTRUCTIONS FOR LAUNDERING TOWELS, TABLE-LINEN, SASH-CURTAINS, CAP, AND APRON

Washing. — Put any very soiled pieces to soak. Wash, rinse, and blue, according to directions given above. All may be washed in one water, in the following order: table-linen, dish-towels, side-towel or hand-towel, cap, apron, and curtains. Boil the towels.

Starch cap and apron first, then curtains. The appearance of a thin table-cloth is improved by dipping it in very thin starch.

Several small flat pieces may be rolled together after sprinkling. If the curtains are thin, make them very damp, or some of the fabric may dry before the iron reaches it. If this happens, dampen with a damp cloth.

Ironing plain pieces. — Straighten each piece and pull corners square. It is almost impossible to iron curtains on a board without stretching them out of shape. Large curtains must be dried on a frame. Have the iron very hot for linen. Iron heavy linen on both sides. Fold napkins into accurate squares. Fold a table-cloth right side out, first making a lengthwise fold down the middle.

Ironing starched pieces. — In ironing the apron, do the bib first, next the band and strings, the body of the apron last. Iron the gathers till they are dry, running the point of the iron up into them. If the cap is not made so that the gathers can be let out for laundering, a small iron will be useful for the crown. If there is a band, lay that along the edge of the table and iron it first. Do the frill next, and the crown last, ironing it on the inside.

BRIEF REFERENCE LIST

For further development of topics treated in this section see:—

BALDERSTON: *Laundrying*.

VAIL: *Approved methods for home laundrying*.

MORRIS: *Household science and art*. Chapter on Laundrying.

KINNE AND COOLEY: *Foods and household management*. Ch. 23, Laundrying and dry cleansing.

SNELL: *Elementary household chemistry*. Ch. 22, Hard water; 23, Ammonia; 26–29, Soaps; 30, Cleaning of fabrics; 42, Bleaching and bluing.

CHAPTER XV

DIGESTION

A GENERAL VIEW OF DIGESTION

What digestion is. — All foodstuffs except water, mineral salts, and two of the sugars have to undergo a process of change called digestion before they can be built into the body. Digestion means taking apart. Foodstuffs, like all other substances, are considered by chemists to be composed of minute particles, which are called molecules (*little masses*). Whenever the molecules of any substance are divided, the substance is changed into something else. This is called a *chemical* change. (See physical and chemical changes, p. 55.) Protein molecules are larger than the molecules of most other substances, but even they are far too small to be seen, even with a microscope. Digestion splits up the molecules of proteins, fats, starches, and some sugars, forming smaller molecules of new substances. Usually repeated splittings occur. Fat molecules have to be split only once, but protein and starch molecules are split many times. At last molecules are formed which are small enough to enter the cells of the body. As a rule, at each splitting, the new substances formed unite chemically with a certain amount of water. This chemical union with water is called *hydrolysis*. Repeating to yourself, "Split and take up

water; split again and take up water," will help you to remember the most prominent feature of digestion.

Digestibility. — People often say this or that food is "indigestible," when they mean that some people feel discomfort after eating it. This is a wrong use of the term. An indigestible food would not be a food at all. Some foods are more *quickly* digested than others, but the quickly digested food may not be so completely digested as one which takes a longer time. Cheese is more *completely* digestible than rice. It is best to avoid the word indigestible except when referring to cellulose, grape-seeds, or things of that sort, and to use the word *digestible* only in the sense of completeness of digestion. Very large percentages of ordinary foods are digestible.

The process of digestion and the digestibility of foods are affected by many things. Among these are the quantity of food eaten, its taste, the way it is cooked, and the state of mind and body of the person who eats it. Unhappy feelings interfere with digestion. Good cheer at the table promotes good health.

The alimentary canal. — When food is swallowed, it goes down a soft muscular tube, the œsophagus, to the stomach. The stomach is a pouch with muscular walls and a soft, smooth lining. After being partly digested in the stomach, the food passes through a narrow opening into another muscular tube, the small intestine. Here it is further digested and most of the products of digestion are absorbed. The material left passes into the large intestine, from which there is an exit for waste. Mouth, œsophagus, stomach,

small intestine, and large intestine are spoken of together as the alimentary canal.

Mechanical and chemical changes in digestion. — The only stage of digestion of which a healthy person is conscious is that which takes place in the mouth. Here teeth, tongue, and face-muscles work together to divide the food and mix it with saliva. The saliva softens and partially dissolves it. The muscles of the stomach and intestines continue working the food about and squeezing it along. At the same time the digestive juices flow into the stomach and intestines and mingle with the food, so that it becomes constantly more finely divided, liquefied, and dissolved. These mechanical changes aid digestion, but it is the chemical changes which really digest the food.

Digestive enzymes. — These chemical changes are brought about by the action of enzymes. We are already familiar with the work of a few enzymes. (See *Enzyms*, p. 131.) It is hard to say exactly what enzymes are, because not enough of one can be obtained for a satisfactory examination. They seem to be substances secreted by living cells, which can work chemical changes in other substances without themselves undergoing change. Each digestive enzyme works on one class of foodstuffs only, in some cases, on a single foodstuff. The enzyme, amylase, acts on all starches, but there is a different enzyme for each sugar.

Digestive juices. — Each digestive enzyme is a constituent of some digestive juice. Some of these juices come from the walls of the alimentary canal, some from organs lying near the canal. *Saliva* is secreted chiefly by three pairs of glands

near the mouth. It furnishes *amylase*, also alkaline salts which favor the action of amylase. *Gastric juice* is secreted by glands in the stomach wall. It furnishes three enzymes, *pepsin*, *rennin*, and *lipase*. Gastric juice also contains *hydrochloric acid*, without which pepsin will not act. *Pancreatic juice* is so called because it is secreted by the pancreas, a large gland back of the stomach. It flows into the small intestine through a duct. Pancreatic juice contains amylase and lipase, and a third substance, which soon becomes the enzyme *trypsin*. Glands in the intestinal wall secrete a mixture of fluids known as the *intestinal juice*. These contribute at least five enzymes. Another fluid, *bile*, enters the small intestine through a duct from the liver. Bile contains no enzymes. It contains other substances, however, which aid the digestion and the absorption of food, particularly of fats.

WHERE EACH FOODSTUFF IS DIGESTED

Let us follow a meal through the alimentary canal and see what happens to each foodstuff.

Digestion in the mouth. — In the mouth amylase begins to digest starches, by splitting them into dextrins. If the food stays in the mouth long enough, a little of the dextrin may be split into sugar (maltose) and dissolved. Saliva also dissolves any salt and sugar not in solution when eaten.

Digestion in the stomach. — When starch enters the stomach, its digestion is under way. Proteins and fats enter the stomach unchanged. Pepsin is a protein-splitting

enzym. It changes (hydrolyzes) proteins into compounds simpler than proteins. Lipase splits fats, but the lipase in the stomach seems to act only on emulsified fats and not very strongly on these. Rennin curdles milk. Its action is an exception to the general rule that digestion liquefies. Pepsin, however, soon liquefies the curd formed by rennin. Amylase continues to digest starch in the stomach until that part of the stomach contents upon which it is working becomes acid from mingling with hydrochloric acid.

Gradually the stomach contents becomes a grayish pulp. This pulp, called *chyme*, escapes little by little into the small intestine. After a meal which has included all the food-stuffs, chyme contains dextrins and sugars; perhaps some undigested starch; proteins and the first products of protein-digestion; fat, and perhaps a little fatty acid and glycerin formed by the splitting of fat. Gastric digestion is preparatory to intestinal digestion.

Intestinal digestion is very complex. Pancreatic juice, intestinal juice, and bile mingle and act together on the chyme. The half-digested proteins and fats are further digested. Starch digestion continues. All sugars that require digestion are digested here. Grape-sugar and fruit-sugar undergo no change.

At last the food is ready for the body to use.—All the sugars present appear as two or three of the simplest, most soluble kinds. The proteins, having passed through many changes, are reduced largely to amino-acids. The fats have been split into glycerin and fatty acids. A part, at least, of these fatty acids is converted into soap before being

absorbed. All these products of digestion are mixed together into a creamy fluid termed *chyle*.

Absorption of food. — A little food may be absorbed from the stomach, and a very little from the large intestine, but the bulk of it is absorbed from the small intestine. While digestion is going on, the products formed are being sucked up through tiny thread-like cells called villi, which project into the stream of chyle. The details of absorption and assimilation are wonderfully interesting, but as they are not directly affected, as digestion is, by the way food is prepared, we do not need to consider them in connection with cooking.

BRIEF REFERENCE LIST

For further development of topics treated in this section see: —

- RITCHIE: *Primer of physiology*. Ch. 8, Digestive organs; 9, Digestion, absorption, and oxidation; 10, Dietetics.
- SHERMAN: *Chemistry of food and nutrition*. Ch. 2, 3, and 4.
- STILES: *Nutritional physiology*. Ch. 6–11, Digestion; 22 and 23, Hygiene of nutrition; 25, Internal secretion.
- BUCHANAN: *Household bacteriology*. Ch. 22, Enzymes of microorganisms.
- FOWLER: *Bacteriological and enzym chemistry*. Ch. 5, 6, and 7.

TABLE OF 100-CALORIE PORTIONS

That quantity of a given food which will supply just 100 calories is called the "100-calorie portion" or "standard portion." The following table gives standard portions of a number of common foods. It also shows how many calories out of the 100 are supplied by the protein, how many by the fat, and how many by the carbohydrate, in each food.

Food	WEIGHT IN OUNCES OF 100- CALORIE PORTION	NUMBER OF CALORIES SUPPLIED BY		
		Protein	Fat	Carbo- hydrate
Beef rib, uncooked	1.8	42	58	0
Beef rib, roasted	0.9	18	82	0
Leg of mutton, uncooked	1.8	41	59	0
Leg of mutton, boiled	1.2	35	65	0
Lima beans, canned	4.5	21	4	75
String beans, cooked	16.7	15	48	37
Cabbage, uncooked	11.	20	9	71
Potatoes, baked	3.	11	1	88
Potatoes, boiled	102.	11	1	88
Apples	7.5	2	6	92
Bananas	3.5	5	6	89
Milk	4.9	19	52	29
Buttermilk	9.9	34	12	54
Butter	0.5	.5	99	0
Cheese8	25	73	2
Eggs	2.4	36	64	0
Honey	1.	1	0	99
Granulated sugar9	0	0	100
Flour9	10.8	1	74.8
Bread	1.3	14	4	82
Cornmeal	1.	10	5	85
Tapioca, cooked	3.9	1	1	98
Macaroni	1.	15	2	93
Macaroni, cooked	3.9	14	15	71
Oatmeal9	16	16	68
Oatmeal, cooked	5.6	18	7	75
Peanuts, shelled6	19	63	18
Walnuts, shelled5	10	83	7

A LIST OF ALL PUBLICATIONS REFERRED TO IN THIS BOOK, WITH SOME ADDITIONS

BIBLIOGRAPHIES

LANGWORTHY, C. F. State and municipal documents as sources of information for institution managers and other students of home economics. Reprint from *Journal of home economics*, Feb. 1912.

LANGWORTHY, C. F. U. S. government publications as sources of information for students of home economics. Reprint from *Journal of home economics*, Feb. 1912.

U. S. Department of agriculture.

Farmer's bulletin list. (Issued several times a year.)

Monthly list of [department] publications.

Publications of the office of agricultural instruction.

List of U. S. Department of agriculture publications of interest to teachers of home economics.

Circulars on girls' canning and home demonstration work.

NOTE. — Every teacher should keep at hand the above lists of publications of the Department of agriculture, and should have the Monthly list of publications mailed to her regularly. For any publication of the Department of agriculture, apply to the Secretary of Agriculture, Washington, D.C.

U. S. Department of the interior. Bureau of education.

List of [bureau] publications.

List of references on home economics. June, 1913. (Includes references on teaching of home economics in elementary schools, in rural schools, in secondary schools, in colleges and universities, also general references. Valuable.)

Washington, State College of. Home economics — a bibliography for high schools. 1913.

PERIODICALS

- American food journal.* Chi. Monthly \$1.00. (Contains synopsis of food laws, passed or pending. Some laws given in full.)
- Boston cooking-school magazine.* 372 Boylston St., Boston. Monthly. \$1.00 —.
- Bulletin of the American School of Home Economics.* Chi. Quarterly. \$1.00 each.
- Experiment station record.* U. S. Department of agriculture. 2 vols. a year. 10 nos. each. (A technical review of the world's scientific literature pertaining to agriculture. Free only to persons connected with agricultural colleges, experiment stations, and similar institutions, and to libraries and exchanges. Superintendent of Documents will receive subscriptions at \$1.00 a volume. The Record may be found in libraries. Most of the matter of interest to teachers of home economics will be found under the heads: Food. Human nutrition.)
- Good housekeeping.* International Magazine Co. N. Y. Monthly. \$1.00.
- Housewives league magazine.* (Housewives League. 27 E. 22d St., New York.) Monthly. \$1.00 a year.
- Journal of home economics.* American home economics assoc., Roland Park, Balto. Bi-monthly. \$2.00. (Contains bibliography of current literature on home economics.)
- Medical record.* 51 Fifth Ave., N. Y. Weekly. \$5.00.
- National geographic magazine.* Wash. D. C. Monthly. \$2.50.
- Scientific American.* 361 Broadway, N. Y. Weekly. \$3.00.
- Table-talk.* Cooperstown, N. Y. Monthly. \$1.00.
- Teachers college record.* Teachers College. Columbia University.
- World's work.* Doubleday Page. N. Y. Monthly. \$3.00.
- Year book* of the U. S. Department of agriculture. Annual. (Reprints of single articles are in many cases obtainable.)
- New York. (Journal devoted to school problems.) 5 nos. a year. \$1.00.

PAMPHLETS

(For federal government publications see bibliographies.)

American home economics association. Balto. Syllabus of home economics.

- Cornell University, Ithaca, N. Y. Cornell reading course for the farm home.
- Florida State College for Women. Department of home economics. Extension bulletins. Sent free upon application.
- Health Education League. 113 Devonshire St., Boston. Booklets. (Send for list and prices. Under certain conditions may be obtained free.)
- Housekeeping experiment station. 28 Hoyt St., Stamford, Conn. 4-p. bulletins: 10 cents. 20-p. bulletins: 25 cents. Send for list.
- New York Milk Committee. 105 E. 22d St., N. Y. City. Milk — its value to the home — its care in the home. Illus. leaflet. Free on request.
- Ohio State University, Columbus, O. Homemakers' reading course. Series of bulletins.
- Sunset Route (Southern Pacific R.R.). Texas and Louisiana rice. How it is grown and cooked. Free.
- Teachers College, Columbia University, New York. Technical education bulletins. (Especially No. 12. Address list for illustrative materials and laboratory supplies for instruction in household arts, 1910. 10 cents; No. 14. A year's work in the industrial arts in the fifth grade. 1912. 15 cents; and Series A, No. 3. The feeding of young children, by Mary Schwartz Rose.)
- University of Illinois, Urbana, Ill. Bulletins. (Especially those of department of household science.)
- Washburn-Crosby Co. Wheat and flour primer. (Free.)

HOME ECONOMICS IN RELATION TO LIFE

- BEARD, CHARLES A. and MARY RITTER. American citizenship. Macmillan. 1914. \$1.00. (Text-book for high schools. Chapters 2 and 3 in particular show relation of government to food, clothing, shelter, the home, and the family.)
- EARLE, ALICE MORSE. Home life in colonial days. Macmillan. 1906. \$2.50. (Standard lib. ed. \$.50.)
- HUNT, CAROLINE L. Life of Ellen H. Richards. Whitcomb and Barrows. 1912. \$1.50. (Interesting and inspiring to teachers and older students of home economics.)
- MASON, O. T. Woman's share in primitive culture. Appleton. \$1.75.

SCIENCE¹

- BIGELOW, MAURICE A. and ANNA N. Applied biology. Macmillan. 1911. \$1.40.
- BROWNLEE, HANCOCK, FULLER, SCHON, and WHITSIT. First principles of chemistry. Allyn and Bacon. 1907. \$1.25. (A high school chemistry.)
- BUCHANAN, ESTELLE D. and ROBT. EARLE. Household Bacteriology. Macmillan. 1913. \$2.25. (Best textbook on bacteriology for the teacher of home economics.)
- COHN, DR. LASSAR-. Chemistry in daily life. Popular lectures. 5th ed., rev. and aug. Lippincott. 1913. \$1.75.
- CONN, H. W. Bacteria, yeasts, and molds in the home. Ginn. 1912. Same text as ed. of 1903. \$1.00. (Good pictures of microorganisms, showing their effects on food.)
- DOANE, RENNIE W. Insects and disease. Holt. 1910. \$1.50. Treats also of microorganisms in relation to disease. (Well illus. Full bibliography with notes.)
- DODD, MARGARET E. Chemistry of the household. American School of Home Economics. 1907. \$1.50. Textbook ed. 1910. \$1.25.
- ELLIOTT, S. MARIA. Household bacteriology. By the same. Household hygiene. American School of Home Economics. Chi. 1907. \$1.50 each. Textbook ed. 1910. \$1.25.
- FOWLER, GILBERT JOHN. An introduction to bacteriological and enzyme chemistry. Longmans. 1911. \$2.10. (Technical. Assumes thorough knowledge of chemistry.)
- GRANT, JAMES. Chemistry of bread-making. Longmans. 1912. \$1.50.
- LYNDE, CARLETON J. Physics of the household. Macmillan. 1914. \$1.25.
- MCPHERSON, WM. and HENDERSON, WM. E. First course in chemistry. Ginn. 1915. \$1.25.
- MORGAN, W. C. and LYMAN, J. A. Chemistry: an elementary textbook. Macmillan. 1911. \$1.25.
- NORRIS, JAS. F. Principles of organic chemistry. McGraw Hill. 1912. \$2.50.

¹ It is best to use the latest edition of any scientific work.

- PRUDDEN, T. M. Story of the bacteria. 2d ed., rev. and enl. Putnam. 1910. \$.75.
- RICHARDS, ELLEN H. Sanitation in daily life. Whitcomb and Barrows. 1907. \$.60. (Technical. Mrs. Richards' books are suitable for teachers only.)
- RICHARDS, ELLEN H. and ELLIOTT, S. MARIA. Chemistry of cooking and cleaning. 3d. ed. Whitcomb and Barrows. 1907. \$1.00.
- RITCHIE, JOHN W. Human physiology. World Book Co. Yonkers-on-Hudson. 1909. \$.80. (Simple clear style.)
- SHERMAN, HENRY C. Chemistry of food and nutrition. Macmillan. 1911. \$1.50. (A standard authority. Devotes especial attention to the mineral compounds in food.)
- SNELL, JOHN F. Elementary household chemistry. Macmillan. 1914. \$1.25.
- STILES, PERCY G. Nutritional physiology. Saunders. 1912. \$1.25. (Readable and reliable.)
- THORPE, SIR EDWARD. Dictionary of applied chemistry. 5 vol. rev. ed. 1913. Longmans. Each v. \$13.50.
- VULTÉ, HERMANN T. and GOODELL, GEO. A. Laboratory notes in household chemistry for the use of students in domestic science. Chemical Pub. Co. Easton, Pa. 1911. \$1.25. For advanced or normal students.

FOOD PRODUCTS

- BAILEY, E. H. S. Source, chemistry, and use of food products. Blakiston. 1914. \$1.60.
- CARPENTER, FRANK G. "How the world is fed." Am. Book Co. 1907. \$.60. (One of a series of industrial readers. Good illus.)
- DONDLINGER, PETER TRACY. The book of wheat. Judd. 1908. \$2.00. (Illus. Bibliog.)
- EDGAR, WM. C. The story of a grain of wheat. Appleton. 1903. \$2.00. (Chiefly historical and commercial. Material for compositions. 40 illus.)
- FREEMAN, W. G. and CHANDLER, S. E. World's commercial products. \$3.50. (Written from English point of view. Good book. Good illustrations.)

- OLSEN, JOHN C. Pure foods — their adulteration, nutritive value, and cost. Ginn. 1911. \$.80.
- ROSENAU, M. J. The milk question. Houghton Mifflin. 1912. \$2.00. ("Valuable contribution to the subject not only of milk, but of foods and sanitation." From review in *Journal of home economics*.)
- SHERMAN, HENRY C. Food products. Macmillan. 1914. \$2.00. (Contains in compact form the information about food most needed by teachers of cookery. May be referred to for the further development of nearly every topic treated of in this textbook. Valuable reference-lists follow each chapter. Contains information about food-laws and food-inspection.)
- SNYDER, HARRY. Human foods and their nutritive value. Macmillan. 1910. \$1.25.
- VULTÉ, HERMANN T. and VANDERBILT, SADIE B. Food industries. Chemical Pub. Co. Easton, Pa. 1914. \$1.75.
- WARD, ARTEMAS, compiler. The grocer's encyclopedia. A compendium of useful information concerning foods of all kinds . . . for grocers and store-keepers. Artemas Ward. 50 Union Sq., New York. 1911. \$10.00. (747 p., 8½" × 11". An excellent reference-book. Contains many fine colored plates besides uncolored photogravures.)
- WHYMPER, R. Cocoa and chocolate. Blakiston. 1912. \$5.00.
- WILEY, HARVEY W. Foods and their adulteration. 2d ed., rev. and enl. 1911. Blakiston. \$4.00.
- WING, HENRY H. Milk and its products. Macmillan. 1907. \$1.50.

FOOD PREPARATION. NUTRITION

- BEVIER, ISABEL and VAN METER, ANNA R. Selection and preparation of food. Laboratory guide. Whitcomb and Barrows. 1907. \$.75.
- CHITTENDEN, RUSSELL H. Nutrition of Man. Stokes. 1907. \$3.00.
- CONDIT, ELIZABETH and LONG, JESSIE A. How to cook and why. Harper. 1914. \$1.00.
- DAVIS, NATHAN S., JR. Food in health and disease. Blakiston. 1912. \$3.50. (Includes infant feeding.)
- FARMER, FANNIE M. Boston cooking-school cook-book. Rev. 1914. Little Brown. \$1.80.

- FARMER, FANNIE M. Food and cookery for the sick and convalescent. Rev. with additions. Little Brown. 1913. \$1.60.
- FRIEDENWALD, JULIUS and RUHRAH, JOHN. Dietetics for nurses. 3d ed., rev. and enl. W. B. Saunders. 1913. \$1.50.
- GIBBS, WINIFRED S. Food for the invalid and the convalescent. Macmillan. 1912. \$.75. (For people who must practice rigid economy. Based on author's experience as dietician for the N. Y. Association for Improving the Condition of the Poor.)
- GREER, EDITH. What children should eat. Human welfare publications. Southwest Harbor, Me. 1911. \$.25. Paper. 20 p.
- GREER, EDITH. Food — what it is and does. Ginn. 1915. \$1.00.
- HILL, JANET MCK. Practical cooking and serving. Doubleday Page. 1908. \$2.00. (Instructions for formal serving only.)
- HILL, JANET MCK. The up-to-date waitress. Little Brown. 1910. \$1.50.
- HILL, SARAH C. Cook-book for nurses. Whitcomb and Barrows. Boston. 1911. \$.75.
- HUTCHISON, ROBERT. Food and the principles of dietetics. W. Wood and Co. 1911. \$3.00.
- JORDAN, WHITMAN H. Principles of human nutrition. Macmillan. 1912. \$1.75.
- LINCOLN, MARY J. Boston Cook-book. Rev. ed. 1904. Little Brown. \$2.00.
- LINCOLN, MARY J. and BARROWS, ANNA. Home science cook-book. Whitcomb and Barrows. 1910. \$1.00. (No recipes. Describes methods for inexperienced cooks. Classified under "breakfast," "luncheon," "dinner.")
- MENDEL, LAFAYETTE B. Childhood and youth. Stokes. 1906. \$.60. (Paper read before New Haven Mothers' Club.)
- NESBITT, FLORENCE. Low-cost cooking. American School of Home Economics. Chi. 1915. \$.50.
- NORTON, ALICE P. Food and dietetics. American School of Home Economics. Chi. 1907. \$1.50. Textbook ed. 1910. \$1.25.
- PATTEE, ALIDA F. Practical dietetics with reference to diet in disease. 6th ed., rev. and enl. A. F. Pattee. 134 S. 1st Av., Mt. Vernon, N. Y. 1910. \$1.50.
- RICHARDS, ELLEN H. The cost of food: a study in dietaries. 1901.

The cost of living as modified by sanitary science. 1899. The cost of shelter. 1905. Wiley. \$1.00 each.

ROSE, MARY S. Laboratory handbook for dietetics. Macmillan. 1912. \$1.10. (Tables and instructions for calculating dietaries. For teachers and advanced students.)

HOUSEHOLD EQUIPMENT AND MANAGEMENT

BALDERSTON, L. RAY. Laundering. L. Ray Balderston. 1224 Cherry St., Phila. \$1.25.

CHILD, GEORGIE BOYNTON. The efficient kitchen. Robert M. McBride. 1914. (For equipment.) \$1.25.

KINNE, HELEN. Equipment for teaching domestic science. Whitcomb and Barrows. 1911. \$.80.

LANCASTER, MAUD. Electric cooking, heating, and cleaning. Van Nostrand. 1915. \$1.50. 305 illus. American edition revised by Stephen L. Coles.

MASON, WM. P. Water supply. 3d ed. Wiley. 1902. \$4.00. (Exhaustive.)

PARLOA, MARIA. Home economics. Century. 1906. \$1.50.

SPRINGSTEED, ANNE FRANCES (MRS. THOS. COLE). The expert waitress. Harper. 1912. \$1.00. (For servants. Simple. Clear. Chapters on Carving and In the invalid's room.)

TERRILL, BERTHA M. Household management. American School of Home Economics. 1907. \$1.50. Textbook ed. 1910. \$1.25.

VAIL, MARY. Approved methods for home laundering. Proctor and Gamble. Sent free. Advertising booklet, but very good.

WHITE, MARION. Fuels of the household. Whitcomb and Barrows. 1909. \$.75.

CARE OF CHILDREN

COTTON, ALFRED C. The care of the child. American School of Home Economics. Chi. 1907. \$1.50. Textbook edition. 1910. \$1.25.

DENNETT, ROGER H. The healthy baby. Macmillan. 1912.

DENNETT, ROGER H. Simplified infant feeding. Lippincott. 1915. \$3.00.

HOLT, L. EMMETT. The care and feeding of children. 8th ed., rev. and enl. Appleton. 1915. \$.75.

TEXTBOOKS

- CONLEY, EMMA. Nutrition and diet — a textbook for secondary schools. Am. Book Co. 1913. \$.60. (Useful for pupils.)
- CONLEY, EMMA. Principles of cooking. Am. Book Co. 1914. (Chiefly practical. Has chapter on teaching in rural schools.) \$.52.
- FORSTER, E. H. and WEIGLEY, M. Foods and sanitation. A textbook and laboratory manual for the high school. Row, Peterson, and Co. 1914. \$1.00.
- GREER, CARLOTTA C. Textbook of cooking. Allyn and Bacon. 1915. \$1.25.
- KINNE, HELEN and COOLEY, ANNA M. Shelter and clothing. Macmillan. 1913. Foods and household management. Macmillan. 1914. Each \$1.10. (For use in high and normal schools.)
- KITTREDGE, MABEL HYDE. Practical home-making. A textbook for young housekeepers. Century. 1914. \$.50.
- MORRIS, JOSEPHINE. Household science and arts. Am. Book Co. 1913. \$.60. (Suggestive along practical lines. Contains, besides chapters on cooking, short chapters on other household topics, including household accounts and home-maker's duty to herself, also one on school-gardens.)

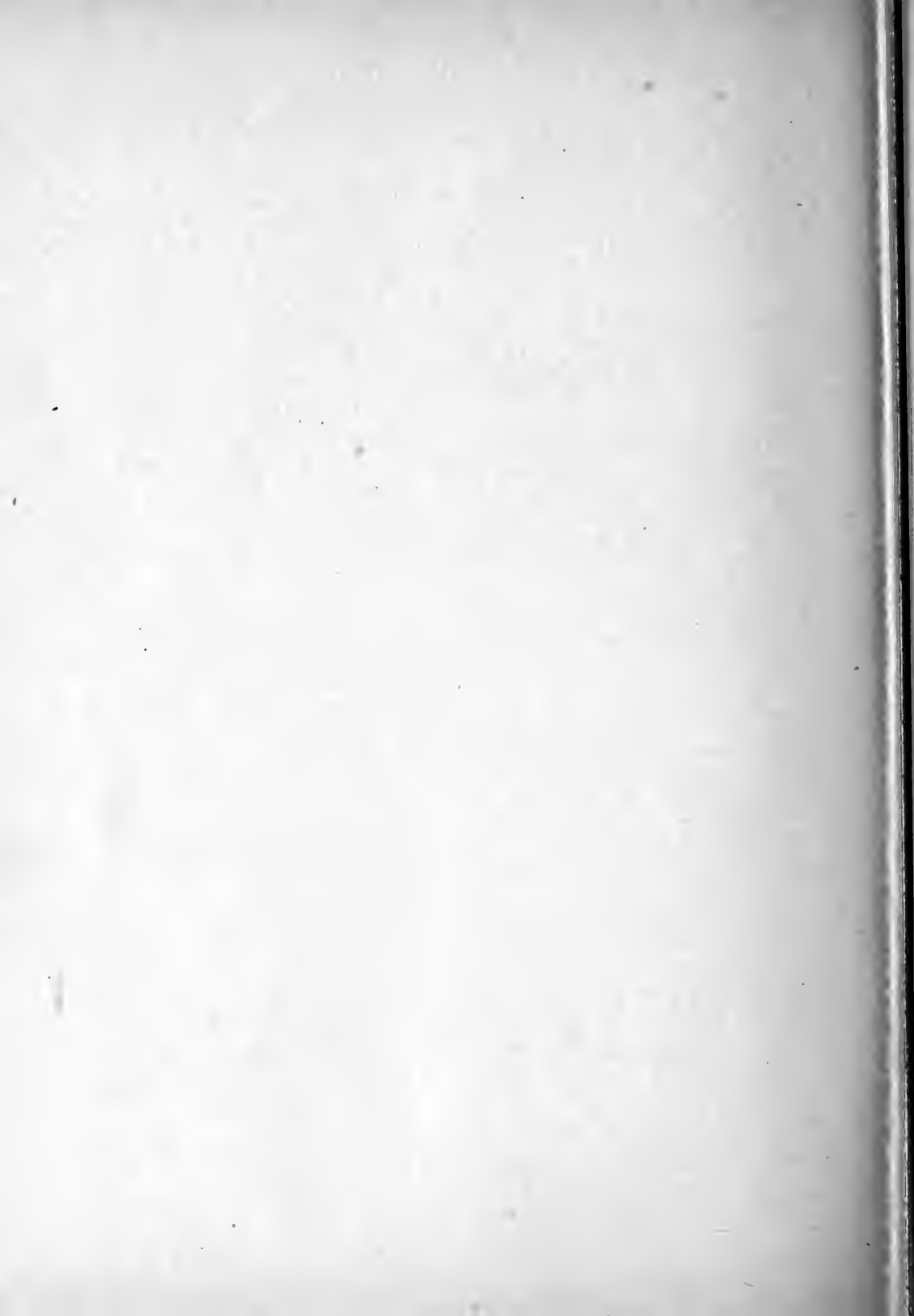

INDEX

- Abbreviations, table of, 52.
Abrasives, cleaning by, 32.
Absorption of food in the body, 371.
Acetic acid, formation of, on dough, 132.
Acids :
 action of, on metals, 57.
 carbonates, action of, on, 108.
 experiments with soda and alkalies, 107, 108.
 foods supplying, to the body, 143.
 function in the body, 143.
 hydrochloric acid in gastric juice, lactics, 86.
 lactic, 96, 97.
 metals, action of, on, 57.
 neutralization of, by alkalies, 109.
 nitric acid, test for nitrogenous substances, 86.
 percentage of, in liquors, 144.
 use of, in cleaning, 34.
Adulteration in coffee, test for, 341.
Air :
 batters made light by beating in air, 107.
 cleanliness, as aid to, 30.
 composition of, 5.
 natural cleaner, 30.
 relation of, to fire, 6.
 testing, for carbon dioxide, 6.
Albumin :
 coagulation of, 86, 87, 167.
 digestion of, 86.
 effect of boiling on, 160.
 effect of frying on, 157.
 effect of heat on, 84.
 in cheese, 101.
 in eggs, 84.
 in meat, 141.
 in milk, 93, 95.
 in potatoes, 88.
 test for, 86.
 use of, in body, 85.
Alcohol :
 effect on body, 144.
 in yeast, 132.
 preservative, 296.
 produced by yeast, 131.
Alcoholic liquors, 144.
Alimentary canal :
 digestion of food in, 367.
 structure of, 367.
Alkalies :
 common form, 57.
 experiments with acids and, 107.
 for modifying milk, 314.
 grease removed by, 33.
 kinds of, 33.
 neutralization of acids by, 109.
Aluminum :
 care of aluminum ware, 43.
 cleaning, 43.
Ammonia :
 grease removed by, 33.
 hard water, softening with ammonia, 25.
Amylase, 370.
Amylopsin in pancreatic juice, 197.
Animal foods, 150-212.
 See also Meat.
Apple :
 baked, 234.
 composition of, 229.
 dried, 236.
 for crab-apple jelly, 307.
 for jelly, 306-307.
 sauce, 233.
 study of, 228, 229.
Apple sauce, recipe for, 233.
Apple tapioca, recipe for, 286.
Apricots, 236.
Apron, special directions for laundering, 365.
Aroma, 340.
Articles used in cleaning, 46.

- Ash, in food, 140.
- Asparagus :
 information about, 248.
 soup, 254, 255.
 soup, use of asparagus water for, 165.
 vegetable soup, 165.
- Assimilation of food, 165.
- Baby :
 artificial feeding, 309.
 care of feeding bottles, 312.
 feeding of, 309.
 food for, 309.
 fresh milk substitutes for, 323.
 general instructions about feeding, 325.
 gruel for, 316.
 pasteurized milk for, 321-323.
 preparing food for, 311.
 water necessary for, 325.
- Bacon, directions for cooking, 218.
- Bacteria :
 causing typhoid fever, 295.
 compared with yeast, 295.
 disease produced by, 30.
 experiment in growing, 295.
 harmless, 296.
 increase of, 295.
 in dust, 30.
 in impure water, 24.
 in milk, 97.
 in relation to cleanliness, 30.
 life history of, 295.
 seen under microscope, 295.
 souring of milk caused by, 96.
 spores of, 296.
 study of, 294.
- Baking :
 apples and pears, 234.
 bakeries, 137, 138.
 bread, 112, 125.
 definition of term, 48.
 fish suitable for baking whole, 202.
 potatoes, 59, 65.
 quick breads, 112.
 using gas range for, 195.
- Baking dishes, 355.
- Baking-pans, greasing, 105.
- Baking-powder :
 composition of, 107, 108.
 different kinds of, 109.
- Baking-powder :
 in biscuit, 107.
 in quick breads, 112, 113.
 leavening power, 107, 108.
 proportion to flour, 111.
 starch in, 110.
 study of, 107.
- Baking-soda :
 a carbonate, 107.
 how it makes griddle cakes light, 108.
 in baking-powder, 108.
 study of, 107.
 test for, 109.
 use with sour milk, 109.
- Bananas :
 baked, 234.
 composition of, 229.
 serving of, 232.
See Fruit.
- Barley :
 barley water, 318.
 cereal food, 73.
 soup, making and serving, 163.
- Bases, formation of, 157.
- Basting, reason for, 159.
- Bath brick, use of, for cleaning knives, 42.
- Batter :
 action of carbon dioxide on batter, 105, 111.
 definition of, 105.
 kinds of, 111.
 ingredients, means of lightening and shortening, 107.
See also Dough.
- Beans :
 composition of, 245.
 information about, 248.
 preparing for salad, 259.
 proteid food, 238.
- Beating, directions for, 90.
- Beef :
 à la mode, 173.
 corned beef hash, recipe for, 175.
 cuts of, 178.
 cut up for sale, 177.
 description of cut, 178.
 directions for roasting, 159.
 flesh of cattle known as beef, 150.
 how sold, 186.
 how to know good, 155.

Beef :

- location of cuts of beef, 178, 179.
- loin of, 179, 190, 191.
- prepared for eating, 186, 187.
- raw beef sandwiches for invalids, 151.
- recipe for rolled flank of, 173.
- selection of good beef, 155.
- sirloin of, 155, 179, 187.
- stewing, 173.

Beef juice :

- directions for extracting, 151, 152.
- preparing, 334.

Beefsteak :

- broiling, directions for, 156.
- cuts of, 186, 187.
- how sold, 186.

Beef tea :

- directions for preparing, 152, 334.
- recipe for, 152.

Beets, information about, 249.**Beet sugar, 266, 267.****Benzoate of soda, 297.****Beverages, definition of, 144, 337.****Bile, 196, 369.****Biscuits, recipe for tea, 105.****Blacking for stoves, composition of, 45.****Blade of beef, 187.****Bleaching, 360.****Blood, 143.****Bluefish, information about, 209.****Bluing, 362.****Body :**

- compared to steam engine, 71.
- demand for water, 337.
- repairs itself, 72.
- starch fuel for, 70.
- work of, 70.

Bodystuffs and foodstuffs, 139.**Boiling :**

- clothes, 362.
- coffee, 342.
- definition of term, 69.
- directions for, 160.
- fish, 203.
- leg of mutton, 60.
- potatoes, 59, 64.
- sugar, 271.

Boiling-point of water, 25.**Bones :**

- calcium found in, 143.
- effect of cooking on, 164.

Bones :

- soup-stock, use of bones in the making, 162.

- structure and composition of, 163.
- study of, 163.

Borax, 33.**Boric acid, solution, 313.****Bottles, 312.****Brains of calves used as food, 183.****Brain workers, diet for, 147.****Braising :**

- definition of, 49.
- helpful hints about, 174.

Brass, cleaning of, 34.**Bread :**

- baking, 125.
- Boston brown, 114.
- characteristics of good, 118.
- digestion and food value, 137.
- fancy bread recipes, 135.
- hints about making, 127.
- hints on mixing and kneading, 123-125.
- kneading, 125.
- making, 133.
- quick bread, 104.
- reasons for chewing, 137.
- recipe for, 123.
- rising, 125.
- soft corn, 115.
- to toast, 89.
- uses for stale, 134.
- white, 127.
- whole wheat, 127.
- yeast bread, 123.

Bread crumbs, uses for, 134.**Bread pudding :**

- recipe for, 284.
- variations of, 285.

Bread sticks and rolls, making, 126.**Breakfast cereals :**

- cooking, 73, 75, 79.
- hints about, 78.
- proportion of salt and water for, 79.
- time table for cooking, 79.

Breakfast foods :

- care of, 75.
- cereals, 73.
- kinds of, 75.
- method of cooking, 75.
- starch in, 75.

See Cereals.

- Brief reference list, 73, 80, 82, 93, 103, 116, 145, 148, 185, 200, 226, 237, 263, 273, 297, 303, 308, 326, 336, 347, 355, 359, 364, 371.
- Brisket of beef, location of, 179, 188.
- Broiling :
 beef steak, 156.
 best cuts for, 155.
 chops broiled in paper, 335.
 definition of term, 48.
 directions for, 156.
 fish, 202, 203.
 gas range, using for, 19, 156.
 pan broiling, 157.
- Brown gravy, making, 159.
- Brown stew, making, 172.
- Brown sugar, 267.
- Burners of gas ranges, 18.
- Butter :
 composition of, 217.
 food value of, 101.
 maître d'hôtel, recipe for, 157.
 making, 100.
 renovated, 100.
 study of, 100.
 test for, 100.
- Butter cakes, 274, 275.
- Buttered crumbs for scalloped dishes, 121.
- Butterine, composition of, 215.
- Buttermilk, 94.
- Butter, peanut, 215.
- Butter spreaders, 351.
- Buying coal, 17.
- Cabbage :
 cole-slaw, 264.
 information about, 249.
- Cakes :
 directions for baking, 276.
 directions for mixing, 275.
 frosting, icing, and filling for, 281, 282.
 general rules for proportions of ingredients in, 274.
 points to be remembered in making, 280.
 recipes for, 278-280.
 two classes of, 274.
- Calcium :
 in bones, 143.
 in water, 24.
 sulphate, 57.
- Calcium phosphate, in bones, 163.
- Calories, definition of, 146, 147.
- Candle, burning, experiments and explanation, 6, 7.
- Candy :
 butter scotch, 271.
 fondant, 272.
 fudge, 272.
 molasses, 271.
 peanut brittle, 271.
 to make, 271.
- Canned vegetables, serving, 244.
- Canning :
 foods, 302.
 fruit for, 299.
 kettle method of, 302.
 method of, 299, 301.
 outfit for, 299, 302.
 preparing fruit for, 299.
 reasons for, 298.
 to sterilize food for, 297.
- Canning powders, 297.
- Caramel :
 custard, 284.
 from dextrin, 69.
 making, 284.
 potatoes, caramel in, 69.
- Carbohydrates :
 composition of, 72.
 food value of, 146.
 functions of, 72, 141.
 in foodstuffs, 140.
 in vegetables, 240.
 special value of, 142.
- Carbon :
 coal a form of, 17.
 combustion of, 55.
 element in body, 56, 57.
 in starch, 68.
 in wood, 5.
- Carbonates, action of acids on, 108.
- Carbon dioxide :
 experiment for, 6.
 from coal, 18.
 in air, 5, 6.
 in yeast, 129, 131.
- Care of :
 articles used in cleaning, 46.
 dishes, 40.
 faucets, 39.
 garbage pail, 39.

- Care of :
 hard wood floor, 36.
 kitchen floor, 35.
 kitchen towels and cloths, 44.
 oil-cloth, 36.
 refrigerator, 45.
 sink, 39.
 stove, 45.
 waste pipe and trap, 39.
- Carrot :
 foodstuff, 238.
 study of, 237.
- Cartilage surrounding bone, 163.
- Casein, in cheese, 95, 101.
- Caseinogen, 95.
- Celery :
 information about serving, 247, 250.
 vegetable soup, 254.
- Cells :
 in body, 139.
 in starch, 68, 139.
 yeast cell, 139.
- Cereals :
 compared with potatoes, 73.
 directions for cooking, 76.
 double boiler, 74.
 food value of, 78.
 food value of, compared with potatoes,
 73.
 fruit with, 75.
 preparation of, 73.
 served cold, 76.
 steam cooked, 75.
 time table for cooking, 79.
- Chalk, insoluble in water, 23.
- Chartreuse, rice and meat, 176.
- Check damper in coal range, use of, 11.
- Cheese :
 composition of, 87, 102.
 cottage, 98, 101.
 crackers, 102.
 digestibility of, 367.
 fondue, 102.
 food value of, 101.
 ramikins, 103.
 with macaroni, 122.
- Chemical changes, 55.
- Chemical elements and compounds :
 definition of, 56.
 found in food, 56.
- Chemicals, for laundry, 360.
- Cherries, canning, 299.
- Chicken :
 fricassee, 199.
 parts of, 195, 196.
 roasting, 197.
 selecting, 195.
 stuffing for, 197.
 to dress and clean, 195.
- Chicory, 341.
- Chlorine, 57.
- Chlorophyll, 129.
- Chocolate :
 adulteration of, 345.
 composition and food value of, 345.
 hot chocolate, 346.
 manufacture of, 344.
 milk, 344, 345.
 sweet, 344.
- Chocolate icing, 282.
- Chocolate layer cake, 280.
- Chops :
 broiled in paper, 335.
 lamb and mutton, 157, 180, 191, 192.
- Chuck, ribs of beef, location of, 179,
 188.
- Chyme, 370.
- Clam broth, 335.
- Cleaning :
 articles of, 45.
 by friction, 32.
 care of articles used in, 46.
 care of stove and zinc, 45.
 faucet, 39.
 "First aid to," 31.
 garbage pail, 39.
 importance of, 29.
 labor savers, 31.
 metals, 33.
 paint, 36.
 personal cleanliness, 46.
 powders, 33.
 refrigerator, 45.
 scrubbing and sweeping, 35.
 silver, 43.
 sink, 37.
 wood work, 35.
- Cleaning of wheat in manufacture of
 flour, 118.
- Cleansers :
 ammonia, 33.
 chemical, 32.

- Cleansers :
 natural, 30.
 petroleum, 33.
- Clearing soup, directions for, 161.
- Clearing table, 354.
- Clove of garlic for salad flavoring, 260, 261.
- Coagulation, 85.
- Coal :
 artificial gas from, 19.
 economy in use of, 18.
 grades of, 18.
 kind of, 17.
 story of, 16.
 use of, 17.
- Coal range :
 how to manage, 11.
 parts of, 9, 10.
- Cockroaches in kitchen, exterminating, 46.
- Cocoa :
 breakfast, 356.
 composition and food value of, 345.
 cracked, 345.
 manufacture of, 344.
 removing stains of, 364.
- Codfish cakes, recipe for, 224.
- Cod, information about, 208.
- Coffee :
 adulteration, 340.
 directions for making, 342.
 filtered, 343.
 food value, 341.
 in market, 340.
 on plantation, 340.
 study of, 340.
 substitutes for, 342.
- Coffee jelly, 170.
- Coffee rennet custard, recipe for, 99.
- Cold-storage, 84.
- Cole-slaw, 264.
- Collagen, function of, in the body, 164.
- Combustion :
 definition of, 7.
 kindling point, 13.
 products of, 8.
 study of, 5.
- Composition of (charts) :
 bread, 124.
 cereals, 77.
 eggs and cheese, 87.
- Composition of (charts) :
 fats, 217.
 fish, 205.
 fruits, 228.
 meats, 153.
 milk, 94.
 nuts, 214.
 vegetables, 239.
- Compound, definition of, 56.
- Convalescent, diet, 328.
- Cookery, theory and practice, 2.
- Cookies, 279.
- Cooking of food, reasons for, 48.
- Cooking :
 bacon, directions for, 216.
 breakfast food, 75.
 cereals, steam used in, 73.
 effect on digestibility of fats, 216.
 how to work, 52.
 principal methods of, 48.
 suggestions about using, 225.
- Corn, 80.
- Corn meal :
 gruel, 330.
 muffins, 115.
- Cornstarch meringue, recipe for, 286.
- Corn syrup, 268.
- Cottage cheese, 98.
- Cottage pudding, 277.
- Cotton, 313.
- Cottonseed oil, 215.
- Crabs, 212.
- Cracked cocoa, cocoa made from, 342.
- Crackers, cheese, 102.
- Cranberry jelly, 235.
- Cream :
 for butter, 100.
 whipped, 101.
- Creamed fish, preparing, 204.
- Creamed potatoes, recipe for, 65.
- Cream of tartar :
 in baking-powder, 108.
 in fondant, 273.
- Cream of vegetable soups, 254.
- Cream sauce, recipe for, 66.
- Creamy rice pudding, recipe for, 287.
- Croquettes :
 chicken, 223.
 codfish, 224.
 material for, 222.
 potatoes, 223.

- Croquettes :
 rice, 224.
 serving, 355.
 shaping and crumbing, 222.
 white sauce for, 223.
- Cross-rib of beef, location, etc., 179, 188.
- Croutons, to prepare, 253.
- Crumbs :
 buttered for scalloped dishes, 121.
 uses for bread, 134.
- Crustaceans, definition of, 212.
- Crust of bread, composition of, 116, 134.
- Cucumbers, 247.
- Cup cake, making (table), 280.
- Cup custards, recipe for, 92.
- Curd of milk, 93, 96.
- Currant jelly, 306.
- Currants for rolls, 136.
- Custard :
 caramel, 284.
 cup, 92.
 plain, 285.
 rennet, 98, 99.
 to prevent curdling, 285.
- Cutlets, veal, 181.
- Cuts of meat, 177.
- Damper, use of, 11.
- Dates, food value of, 236.
- Decoction, 337.
- Decorating table, 350.
- Decorations, 350.
- Delmonico steaks, description of, 178.
- Desserts, remarks about, 283.
- Dextrin :
 from starch, 69.
 in crust, 116.
- Diastase, 81.
- Diet :
 babies, for, 309, 325.
 importance of, in cases of sickness, 327.
 liquid and light, 327.
 mixed diet, reasons for, 146.
 practical points about feeding a family, 147.
 requirements of, 146, 147.
- Dietaries, calculation of, 147.
- Digestibility of foods, 367.
- Digestion :
 absorption of food, 371.
- Digestion :
 action of digestive juices on articles of food, 369.
 definition of, 366.
 intestinal, 370.
 in the mouth, 369.
 in the stomach, 369.
 juices for, 368.
 mastication of food, 368.
 mechanical and chemical changes in, 368.
 of albumin, 86.
 of bread, 137.
 of fat, 216.
 of fish, 206.
 of meat, 184.
 of milk, 99.
 of poultry and game, 194.
 of quick breads, 115.
 of starch, 70, 366.
 structure of alimentary canal, 367.
 summary of process of digestion, 369.
- Dining room, 349.
- Dinner :
 menu for, 357.
 order of work in preparing, 358.
- Diseased pork, precaution against, 183.
- Dish-cloths, cleaning, 44.
- Dishes, care of, 40.
- Dishing up, general rules for, 355.
- Dish-washing, directions for, 40.
- Disinfectants :
 definition of, 30.
 kinds of, 33.
 preservatives of food, 283.
- Distillate oil, 19.
- Domestic science :
 definition of, 2.
 general value of, 3.
- Double boiler, how to use, 74.
- Dough :
 definition of, 111.
 kneading, 125.
 raising, 125.
- Drafts, explanation of, 7.
- Drafts in coal range, 10.
- Drawn butter, recipe for, 204.
- Dried fruits :
 composition and use of, 229.
 imported fruits, cleaning, 236.

- Drinking water, characteristics of good, 24.
- Drop-batter, definition of, 111.
- Ducks, 195.
- Dumplings for brown beef stew, recipe for, 172.
- Dust :
 definition of, 30.
 kinds of, 29.
 microscopic plants in, 30.
- Dusting, directions for, 36.
- Economy :
 in choosing fresh vegetables, 241.
 in marketing and choosing meat, 183.
 in using the best flour, 120.
 soup an economical dish, 161.
- Egg muffins, recipe for, 113.
- Egg nog, recipe for, 331.
- Eggs :
 albumin in, 83.
 beating, 90.
 breaking and separating, 90.
 care and preservation of, 83.
 composition of, 88.
 digestion of, 86, 88.
 food value of, 88.
 gruel, 331.
 in a nest, 91.
 nog, 331.
 preparations for invalids, 330.
 raw, 330.
 selecting and testing, 84.
 shirred eggs, 331.
 soft cooked, 88.
 study of, 83.
 temperature for cooking, 84.
See also Albumin.
- Electric iron, 364.
- Electricity, cooking by, 21.
- Electrolysis, cleaning silver by, 43.
- Emulsion, experiment to illustrate, 99.
- Endosperm, 117.
- Energy in coal, 17.
- Energy supplied to body by food, 71, 72, 269.
- Entire wheat flour, production of, 119.
- Enzymes, 131, 132, 295, 368.
- Experiments :
 action of cold water on meat, 154.
 butter making, 100.
- Experiments :
 growth of yeast, 128.
 in growing bacteria, 294.
 in heating dry starch, 69.
 nature and action of protein, 151.
 sources of starch, 67.
 sprouting of potato and its composition, 63.
 to find out what potato contains, 61.
 to find temperature for cooking eggs, 84.
 to illustrate emulsion, 99.
 to prevent starch lumping, 68.
 to show action of saliva on starch, 60.
 to show effect of cold and of hot water on meat, 160.
 to show effect of heat on water, 25.
 to show how eggs are digested, 86.
 with a candle, 6.
 with glucose and with white sugar, 265.
 with heated fat, 218.
 with molasses, 268.
- Family :
 points about feeding, 147.
 welfare, 1.
- Fancy breads, recipe for, 133.
- Fancy omelets, 92.
- Farina, steaming, 79.
- Fat :
 animal, 213.
 boiling, 219.
 changing proportion of, in milk, 319.
 clarifying, 220.
 composition of, 213.
 cooking, 218, 225.
 distinguished from oil, 213.
 experiments with heated, 218.
 food value of, 216.
 for frying, 220.
 function of, in the body, 140, 216.
 in foodstuffs, 140.
 lowering content of, in milk, 319.
 removing from stock, 166.
 special value of, 141.
 testing of, for frying, 221.
 use of, for shortening, 225.
 vegetable, 213.
- Faucets, cleaning of, 39.
- Feeding bottles, 312.

- Fehling's solution, test for maltose, 70.
 Fermentation, explanation of, 131, 294.
 Fermented liquors, effect of, on body, 144.
 Fibre:
 in meat, 50.
 in potatoes, 62.
 in vegetables, 240.
 Figs, food value of, 236.
 Fillings for cakes, recipes for, 281.
 Filters, cleansing, etc., 24.
 Finger bowls, 353.
 Finger rolls, making, 126.
 Fire:
 and fuels, 5.
 cleaning fire-box, 11.
 definition of kindling point, 12.
 how to make, 11.
 how to manage, 12, 14.
 laying a fire, 11.
 relation to air, 5-15.
 starting fire, 11.
 Fireless cooker:
 directions for use, 20.
 with gas range, 14.
 Fish:
 cleaning and creaming, 201, 204.
 directions for baking, boiling, and broiling, 202, 203.
 distinction from shellfish, 200.
 food value and digestibility for, 206.
 fresh water, 209.
 how to clean, 201.
 how to know, 201.
 information about, 208.
 kinds of, 208, 209.
 larding, 202.
 methods of preserving, 206.
 reheating, 204.
 salt water, 208.
 sauces for, 202, 204.
 scalloped, 204.
 selecting, 202-203.
 special care in cooking, 206.
 structure of, 201.
 stuffing for, 202.
 suitable for baking, 202.
 suitable for broiling, 202.
 table of information about, 208, 209.
 to prepare for eating, 208, 209.
 Fish balls, recipe for, 222.
- Flame:
 candle, 7.
 definition of, 7.
 Flank of beef, location of, etc., 178, 187.
 Floor:
 care of, 35, 36.
 linoleum covered, 35.
 Flour:
 good bread, 120.
 kinds of, 119.
 manufacture of, 116.
 Flour plaster, macaroni, etc., 120.
 Folding, directions for, 91.
 Fondant, 272.
 Food:
 absorption of, 371.
 acid forming, 143.
 adulteration, 53.
 animal and plant foods, 145.
 base forming, 143.
 composition of, 77.
 definition of, 48.
 directions for, 50.
 for sick, 327.
 functions of, 142.
 importance at regular meals, 348.
 methods of cooking, 58.
 microorganisms in relation to, 294.
 preservation of, 294-308.
 pure, 53.
 reasons for cooking, 58.
 requirements, 146.
 serving of, 348.
 tables, 49, 50.
 valuable properties of, 145.
 waste in, 144.
 Food adjuncts, definition of, 144.
 Foodstuffs:
 composition of, 140.
 when digested, 369.
 Force supplied to the body by food, 78, 143.
 Formula, for modified milk, 317; top milk, 314.
 Fowls, *see* Chickens.
 Freezing, ice cream and ices, 288.
 Freezing point, 27.
 French bread-pans, use of, 131.
 French dressing for salads, 262.
 French omelet, recipe for, 91.

- Fricassee :
 chicken, 199.
 cutting up a fowl for, 198.
 definition of, 199.
- Friction, use of, in cleaning, 32.
- Frosting, 281.
- Fruit :
 addition of sugar and water to, 300.
 cake, 267.
 citrus, 232.
 composition of, 229.
 definition of, 227.
 directions for canning, 301.
 directions for stewing, 233.
 dried, 236.
 effect of cooking on, 231.
 food value of, 229.
 preparing, 231.
 preparing for canning, 299.
 removing fruit stains, 46.
 right sort to can, 299.
 serving, 232.
 sterilizing in jars, 299.
 sugaring, 232.
 suggestions about eating, 230.
 time required for sterilizing, 300.
 with cereals, 75.
- Frying :
 definition, 59.
 digestion of fried food, 216.
 directions for, 221.
 effect on meat and albumin, 251.
 food suitable for, 221.
 oysters, 224.
 points about, 219.
 preparing fat for, 220.
 temperature of fat for, 221.
- Fudge, 272.
- Fuel :
 and fire, 5.
 definition of, 16.
 distilled oil, 19.
 foodstuffs as, 146.
 kerosene, 18.
 kinds of, 16, 17.
 natural gas, 19.
 use of coal, wood, etc., 16-19.
- Fuel foods :
 fat from animals and oil from plants,
 213, 215.
 for the body, 70.
- Fuel foods, starchy plants, 70.
- Game :
 food value of, 194.
 selection of, 194.
- Garbage pail, care of, 39.
- Gas, artificial, natural, 19.
- Gases, explanation of, 27.
- Gasoline, 33.
- Gas range :
 care of, 15.
 how to manage, 15.
 parts of, 12.
 with fireless cooker, 21.
- Gastric juice :
 action on meat, 185.
 composition of, 369.
 effect on proteins, 86.
 enzymes in, 369.
 glands in stomach secreting, 369.
- Gelatine :
 as good food, 171.
 directions for using, 169.
 how made, 170.
 in bones, 164.
 jellies, recipe for, 170.
- Gingerbread, 278.
- Ginger snaps, whole wheat making, 279.
- Glasses, washing, 41.
- Gluten :
 composition of, 117.
 definition of, 116.
 recipe for gluten wafers, 333.
 test for, 117.
- Gold cake, 278.
- Goose, 195.
- Graham flour, 120.
- Granulated sugar, manufacture of, 267.
- Grape-fruit, serving, 232.
- Grape-sugar, definition of, 264.
- Gravy :
 brown, to make, 159.
 giblet, 198.
- Grease, removal of, 33, 35.
- Greasing cake-pans, 267.
- Green pea soup, 253.
- Green vegetables, care and cooking of,
 243.
- Griddle, how to use, 107.
- Griddle cakes, a quick bread recipe, 104-
 106.

- Gristle, 163.
- Gruel :
 corn meal, 330.
 egg, 331.
 for modifying milk, 314.
 shredded wheat, 330.
- Haddock, information of, 208.
- Halibut, information about, 208.
- Hams, 182.
- Hard coal, 17, 18.
- Hard sauce, recipe for, 282.
- Hard water, softening, 24.
- Hard wood floor, care of, 36.
- Harvesting, wheat, 81.
- Hash :
 browning hash, 176.
 corn beef, 176.
 directions for making, 175.
 fish, 203.
 minced meat on toast, 176.
- Health, water in relation to, 28.
- Heat :
 albumin, heat as a test for, 85.
 effect of heat on starch, 68.
 effect of heat on sugar, 265.
 effect of heat on water, 23.
 expansion due to, 27.
 source of, 17.
 yeast, growth of, aided by, 129.
See also Fuel foods.
- Helpful hints about :
 braising and stewing, 174.
 bread making, 133.
 jam and jelly making, 308.
 mixing and baking quick breads, 112.
 soup stock, 160.
- Homemaking :
 business of, 1.
 industries, 1, 2.
 training for, 2, 3.
- Hominy, purchase of and directions for cooking, 76, 79.
- Honey, 267.
- Household science, definition of, 2.
- Housekeeping, women in, 1.
- How to pass food, 354.
- Huckleberries, indigestibility of, 230.
- Human body :
 compared with steam engine, 56.
 elements in, 56.
- Human body :
 food for, 56.
 work of, 70.
- Hydrochloric acid, 86.
- Hydrogen :
 an element in food, 56.
 definition of, 56.
 in starch, 70.
 to form water, 56.
- Hydrolysis, 366.
- Ice :
 freezing point of water, 28.
 in drinking water, 28.
 purity of, 28.
 salt with, in freezing mixture, 287.
 to form a freezing mixture, 287.
See Water ices.
- Ice-box, care of, 45.
- Ice-cream :
 American, 290.
 chocolate, 290.
 directions for freezing, 288.
 flavorings for, 290.
 junket, 290.
 made without freezer, 289.
 peach, 290.
 recipe for plain, 289.
 strawberry, 290.
- Iced tea, 339.
- Ices. *See* Water ices.
- Icings for cake :
 chocolate, 282.
 quick frosting, 281.
 soft frosting, 281.
- Implements and materials for cleaning,
 33, 36, 37, 43.
- Indian corn, 79.
- Indigestion, 367.
- Infusion, 337.
- Ingredients in cakes, proportion of, 274.
- Inorganic, impurities in water, 23.
- Insects in kitchen, extermination of, 46.
- Intestinal juice, 369.
- Invalid :
 diet for, 327-336.
 eggs for, 331.
 gruels for, 330.
 jellies for, 333.
 milk preparations for, 331.
 tray for, 336.

- Iodine, as test for starch, 61.
 Irish moss jelly, 333.
 Irish moss lemonade, 336.
 Irish oats, 76.
 Iron :
 cleaning, 34.
 in blood, 143.
 Ironing :
 irons for, 364.
 plain pieces, 365.
 starched pieces, 365.
 Italian pastes, 121.
 Jam :
 blackberry or raspberry, 304.
 helpful hints about making, 308.
 Jars :
 to sterilize, 298.
 to test, 298.
 Javelle water, 364.
 Jelly :
 best fruits for, 306.
 coffee, 170.
 cranberry, 236.
 directions for making, 306, 307.
 gelatin, 169.
 Irish moss, 333.
 lemon, 170.
 requirements for, 305.
 utensils needed for making, 306.
 wine, 335.
 Junket, ice-cream, 98, 290.
 Kephir, 332.
 Kerosene :
 as cleanser, 33.
 preparation of, 18.
 use of, 18.
 Kindling point, definition of, 12, 13.
 Kitchen towels, and clothes, care of,
 44.
 Kneading, directions for, 125.
 reasons for, 133.
 Knives, steel, cleaning, 42.
 Knuckle of veal, location of, 181.
 Kumiss, 332.
 Labor-savers, 31.
 Lacteals, digestion of fat by, 216.
 Lactic acid, 332.
 Lactose, 95.
 Lamb :
 cuts of, 180.
 directions for roasting, 358.
 good meat, selection of, 182.
 how sweet, 191.
 prepared for eating, 191.
 stewing, 171.
 Larding :
 fish, 202.
 steak, 174.
 Laundering :
 order of work, 361-363.
 special instructions for, 360-365.
 washing machines, 361.
 Laying fires, 11.
 Laying the table, 350-353.
 Leaf-lard, 182.
 Lean meat, 155.
 Leg of mutton :
 broiling, 157.
 location of, 180.
 Legumes, 240.
 Legumin, 240.
 Lemonade :
 Irish moss, making, 336.
 recipe for, 235.
 Lemon ice, 291.
 Lemon jelly, 170.
 Lemon sauce, 282.
 Lemon whey, recipe for, 336.
 Lentiles, 238.
 Lettuce, for salad, 249.
 Light diet for sick, 327.
 Lightening batters, 105-111.
 Light fruit cake, 274.
 Lighting gas ranges, 15.
 Lima beans, information, 246.
 Lime, function in body, 140.
 Lime water, in milk formulas, 318-319.
 Linen, 350.
 Lipase, 369, 370.
 Liquid diet for sick, 327.
 Liquid yeast, 129.
 Liquors, alcoholic, 144.
 Liquors, explanation, 27.
 Litmus paper, test for alkali and acid, 108.
 Loaf sugar, 267.
 Lobster, 212.
 Loganberry, 230.
 Loin of beef, mutton, lamb, 179, 186, 191.
 Luncheon, 359.

- Macaroni, 120.
 baked with cheese, 122.
 composition, 120.
 good macaroni, 120.
 manufacture of, 120, 121.
- Macédoine salad, 260.
- Mackerel, 208.
- Maitre d'hôtel butter, 157.
- Maize, 79.
- Malt, 318.
- Maltose, 318.
- Manufactures :
 chocolate, 344.
 cocoa, 344.
 flour, 118.
 gelatin, 170.
 sugar, 267.
- Maple sugar, manufacture of, 266, 267.
- Marketing, economy in, 183.
- Marmalade, 304.
- Marrow, in bone, 163.
- Mashed potato, recipe for, 65.
- Mastication of food, 194.
- Mayonnaise dressing, 262.
- Meals :
 importance of regular, 349.
 planning, 147.
 preparing, 356.
 suggestions for order of work, 356.
- Measures, directions and tables for, 49, 50-52.
- Meat :
 action of cold water and salt upon, 154.
 care of uncooked, 154.
 chartreuse of rice and, 176.
 cold storage of, 184.
 composition of, 184.
 cuts of, 177.
 digestion of, 184.
 economy in buying, 183.
 food value of, 184.
 inspection of, 183.
 marketing, 177.
 minced on toast, 176.
 preparations for sick, 334-335.
 reasons for cooking, 154.
 salt upon, 161.
 structure of, 150.
 table of information about cuts of, 186-193.
 tough and tender, 155.
- Meat :
 uses for the gelatin parts of, 161.
- Meat pie, 177.
- Melons, 232.
- Menu :
 breakfast, 356.
 dinner, 357.
 luncheon, 359.
- Meringue :
 corn starch, 286.
 egg, 286.
- Metals :
 action of acids on, 57.
 cleaning, experiments, 33.
 rust and tarnish, removing, 34.
- Microörganisms :
 definition of, 294.
 in food, 294.
- Milk :
 action of rennet on, 98.
 analysis, 93.
 bacteria in, 314.
 boiled, 323.
 canned, 323.
 care of, 96.
 composition of, 95, 309.
 condensed, 323.
 diet for babies, 309.
 digestion of, 99.
 directions for buying, 96.
 dried, 324.
 fermented, 332.
 food value of, 95.
 goat, 309.
 good, 96.
 increasing proportion of fat in, 319.
 ingredients used in modifying, 314.
 lactic acid in, 96.
 malted, 324.
 modifying, 310.
 pasteurizing, 322.
 peptonized, 332.
 preparations for invalids, 331.
 preparations for sick, 331.
 skim, 96.
 sour, 96.
 sterilized, 323.
 study of, 93.
 sugar, 315.
 temporary substitutes for fresh, for baby, 323.

- Milk :
 use of skim milk, 320.
 Milk sugar, 266.
 Mince meat on toast, 176.
 Mineral matter :
 importance of, 142.
 in eggs, 88.
 in foodstuff, 140.
 Mint sauce, 358.
 Mixed vegetable soup, recipe for, 168.
 Mixing, directions for, making muffins,
 bread, 113.
 Modifying milk, 310.
 Molasses, 268.
 Molasses candy, 271.
 Molds, 30.
 Muffins :
 a quick bread, 104.
 corn meal, 115.
 egg muffins, 113.
 hints on mixing, 112.
 plain, 113.
 recipes for, 113.
 whole wheat, 113.
 Muscular tissue, 150.
 Muskmelons, serving, 232.
 Mutton :
 boiling leg, directions for, 154.
 chops, broiling, 155.
 cuts of, 180, 191.
 how stewed, 191.
 preparing for eating, 191.
 selection, 155.
 Mutton broth, 334.
 Naphtha soap, 360.
 Napkins, 352.
 Natural science, definition of, 1.
 Neck, 179, 191.
 Nipples :
 care of, 313, 326.
 selection of, 313.
 Nitric acid, test for protein, 151.
 Nitrogen :
 an element in body, 57.
 in air, 5.
 in proteins, 86.
 Nitrogenous foods, definition of, 86.
 Noodles, 121.
 Normal diet :
 directions for seasoning, 74.
- Normal diet :
 explanation of, 146.
- Oatmeal :
 gruel, recipe for, 316.
 steamed whole, 74.
 value as food, 78.
 Oatmeal water for babies, 316.
 Oesophagus, 367.
 Oil-cloth, care of, 36.
 Oils :
 coal, 18.
 cottonseed, 215.
 distilled, 19.
 distinguished from fats, 214.
 frying in olive oil, 218.
 in nuts, 215.
 vegetable, 213.
 Olein, 213.
 Oleomargarine, 215.
 Olive oil, frying in, 215.
 Omelets :
 fancy, 92.
 French, 91.
 Oranges, 232.
See Fruit.
 Order of work, in preparing a meal, 356.
 Organic matter, definition of term, 23.
 Organs, internal, used for food, 183.
 Ossein, 157.
 Ovens :
 coal range, 10.
 construction and management of, 10,
 14, 16.
 for cake, 276.
 Oxidation :
 definition of, 56.
 of food in the body, 171.
 rusting of metals, 34.
 slow and rapid, 72.
 Oxygen :
 as element of food, 56.
 combustion, 7, 8.
 how yeast obtains, 130.
 in air, 5.
 in body, 56.
 in starch, 56.
 properties of, 56.
 Oysters :
 as food, 210.
 directions for frying, 224.

- Oysters :
 for stew, 211.
 how to serve raw, 210.
 preparation of, 210.
 scalloped, 210.
 study and structure of, 207.
- Packing flour, 119.
- Paint, how to clean, 36.
- Palmitin contained in fats, 213.
- Pan-baking, 49.
- Pan-broiling, 49.
- Pancreas, 183.
- Pancreatic juice, composition of and use
 in digestion of food, 370.
- Pans, greasing for cake, 276.
- Paraffin, 304.
- Parker House rolls, recipe for, 135.
- Parsley :
 a garnish, 92.
 cutting, directions for, 66.
 preparing for salad, 259.
- Pasteurization, 97.
- Pasteurizer, 322.
- Pasteurizing milk, 321, 322.
- Pastry, digestion in the body, 218.
- Peaches :
 canning, 299.
 dried, soaking, 236.
- Peach ice-cream, making, 290.
- Peanut brittle, candy, recipe for, 272.
- Pears :
 canning, 299.
 directions for baking, 234.
- Peas :
 analysis of, 238.
 green pea soup, recipe for, 253.
 information about, 250.
 split pea soup (table), 254.
- Pectin :
 definition of, 304.
 in fruit and vegetables, 305.
 test for, 305.
- Pepper, white and black, use of, in cook-
 ing, 65.
- Pepsin :
 experiment showing digestion of eggs,
 87.
 gluten in bread digested by pepsin, 370.
 in gastric juice, 86, 369.
- Peptonized milk, 332.
- Perch, information about, 209.
- Personal cleanliness, 46.
- Phosphorus :
 burning, 13.
 in eggs, 88.
 in milk, 95.
 in nerves, 141.
- Physical changes of matter, 55.
- Pickles, 303.
- Pickling, 303.
- Pineapple, 232.
See Fruit.
- Pineapples, food value, 229.
- Plain bread pudding, recipe for, 284.
- Plain muffins, recipe for, 113.
- Plain spice cake, making, 278.
- Plant origin of coal, 23.
- Plants :
 breathe, 71.
 starchy, 59.
- Plate of beef, location, 173, 178, 179.
- Plums, canning, 299.
- Polished wood, cleaning with kerosene, 35.
- Popovers, 104.
- Pork :
 cuts of, 182.
 how sold, 192.
 prepared for eating, 193.
- Porterhouse steak, 178.
- Potash :
 grease removed by, 33.
- Potato :
 choosing, 63.
 creamed, 65.
 croquettes, recipe for, 223.
 food value of, 66.
 how to cook, 63.
 how to keep, 63.
 how to pare, 63.
 mashed, 65.
 riced, 65.
 salad, recipe for, 263.
 structure of, 62.
- Potatoes :
 baked, 59.
 boiled, 59.
 potash salts contained in, 61.
 study of, 60.
 sweet, 66.
 the analysis of, 61.
 their composition, 62.

- Poultry food value :
 digestion of, 194.
 directions for stuffing, 197.
 how to dress and clean, 195.
 roasting, 197.
 selecting, 194.
- Pour-batter, definition of, 111.
- Powdered sugar, manufacture of, 267.
- Preparations for meal, 352.
- Preparations for sick :
 eggs, 330.
 meat, 334.
 milk, 331.
- Preservation of food, 280.
 eggs, 83.
 fish, 206.
- Preservatives :
 definition of, 296.
 soft sugar, etc., as preservatives,
 296.
- Preserves, definition of, 303.
- Preserving meat, eggs, fruit, etc., 297.
- Prime ribs of beef, location, etc., 174,
 180.
- Protein :
 albumin, 85.
 aleurone, 117.
 casein, 95.
 contains nitrogen, 86.
 digestibility of, 367.
 digestion of, 366.
 food value of, 146.
 in foodstuffs, 140.
 in gluten, 117.
 in milk, 95.
 in vegetables, 238.
 nitric acid test for, 151.
 pulp of meat, consisting of, 184.
 special value of, 141.
 vegetables supplying, 240.
- Protoplasm, definition of, 140.
- Prunes :
 food value of, 228.
 stewing, 236.
- Ptyalin, 70.
- Pudding :
 apple tapioca, 286.
 bread, 284.
 cottage, 277.
 creamy rice, 287.
 plain bread, 284.
- Pudding :
 recipes, 284-288.
 sauces, 282.
- Pure and impure water, organic and
 inorganic impurities, 24.
- Purées :
 bean purée, recipe for, 253.
 definition of purées, 253.
- Pure foods :
 definition of, 53.
 law of, 53.
- Putrefaction caused by bacteria, 296.
- Queen of puddings, recipe for, 285.
- Quick breads :
 definition of, 104.
 digestion of, 115.
 mixing and baking, 112.
 nut, 114.
- Quick frosting for cakes, 281.
- Quinces, for jelly, 306.
- Rack of veal, location of, 181, 190.
- Radishes, serving, 247.
- Raisins :
 food value, 236.
 in pudding, 285.
 stoning, 276.
- Ranges :
 cleaning and care of, 45.
 construction and management of,
 9-16.
See Stove.
- Raw beef sandwiches for invalids, mak-
 ing, 335.
- Raw fruit, eating, rules for, 231.
- Raw meat, care of, 154.
- Raw oysters, serving, 210.
- Raw sugar, manufacture of, 267.
- Raw vegetables, serving, 247.
- Réchauffés :
 directions for making, 175.
 recipes for, 175.
 soup meat used in, 168.
- Recipe for standard cake, 51.
- Red meat, nutriment contained in, 152.
- Refrigerator :
 care of, 45.
 construction, 45.
 weekly cleaning, 45.
- Rendering fat, 218.

- Rennet :**
 action on milk, 98.
 custard, recipe for, 98, 99.
- Rennin, aid in digestion of milk, 99, 369.**
- Resin, 360.**
- Rhubarb sauce, 235.**
- Rice :**
 boiled, 74.
 cereal food, 74.
 chartreuse of rice and meat, recipe for, 176.
 cooking, directions for, 74, 76.
 creamy rice pudding, recipe for, 287.
 making and serving soup, 168.
 savory rice croquettes, 224.
 value as food, 78.
 washing, 75.
- Riced potato, recipe for, 66.**
- Rinsing, 362.**
- Rising of bread, 125.**
- Roasting :**
 basting meat, reasons for, 159.
 definition of term, 48.
 directions for, 154.
 gas range, use of broiling oven for roasting, 14.
- Rolled flank of beef, recipe for, 173.**
- Rolls, bread, making, 126, 135.**
- Roots, bulbs and tubers, 240.**
- Roots, feeding-organs of plants, 238.**
- Rottenstone, use of, for cleaning purposes, 34.**
- Round of beef, location of, 178.**
- Rump of beef, location of, 178.**
- Rust, 34.**
- Rye, 77.**
- Salads and salad-making, 258, 259:**
 arrangement of, 260.
 cole-slaw, 264.
 definition of, 258.
 dressing, 261-262.
 essentials for, 259.
 four essentials in, 259.
 French, 261.
 Mayonnaise, 262.
 mixed vegetable salad, 263.
 potato, 263.
 preparation of, 259.
 reason for eating, 260.
 stuffed tomato, 264.
- Salads and salad-making :**
 tomato, 264.
- Saliva:**
 action on food, 70.
 how secreted, 368.
- Salmon, information about, 209.**
- Sal-soda, see Soda.**
- Salt :**
 action on meat, 154.
 as preservative, 296.
 preservation of food by, 296.
 solubility in water, 22.
- Salt meats, cooking and food value of, 161.**
- Salts :**
 definition of, 57.
 mineral salts in wheat, 116.
- Salt-water fish, table of information, 208.**
- Sandwiches, raw beef, for invalids, 335.**
- Sash curtains: special directions for laundering, 365.**
- Sauces, recipes for :**
 apple, 233.
 caramel, 284.
 drawn butter, 204.
 egg, 204.
 fish, 204.
 hard, 282.
 mint, 358.
 pudding, 284.
 rhubarb, 235.
 stock used instead of water, 167.
 tartar, 204.
 thickening, with starch, 69.
 tomato, 122, 158.
 white, 66, 223, 247.
- Sausages, 182.**
- Sautéing, definition of, and directions for, 49, 218, 225.**
- Savory rice croquettes, recipe for, 224.**
- Scalloped dishes :**
 buttered crumbs for, 121.
 fish, preparing, 204.
 vegetables, 247.
- Scalloped oysters, recipe for, 211.**
- Science, domestic, general value of, 2.**
- Scouring, steel knives, 42.**
- Scrubbing, 35.**
- Scrubbing floors, 35, 36.**
- Seeds, oil contained in, 215.**

- Serving :
 dishes, 355.
 food, 355.
- Sewage, pollution of water, 24.
- Shad, information about, 209.
- Shellfish as food, cooking, etc., 207, 212.
- Shin of beef, location of, 179.
- Shirred egg, recipe for, 331.
- Shortening :
 batters, etc., 111.
 beef fat as, 226.
- Shoulder of mutton, 172, 180.
- Shredded-wheat gruel, recipe for, 330.
- Shrimps, 212.
- Sick, cookery for the :
 albuminized milk, 332.
 arrangement of invalid's tray, 336.
 beef juice, 334.
 chop broiled in paper, 335.
 clam broth, 335.
 convalescent diet, 328.
 cornmeal gruel, 330.
 egg gruel, 331.
 egg preparations, 330.
 fermented milk, 332.
 gluten wafers, 333.
 gruels, 329.
 Irish moss jelly, 333.
 Irish moss lemonade, 336.
 kumiss, 332.
 lemon whey, 336.
 light diet, 327, 328.
 meat preparations, 334.
 milk preparations, 331.
 mutton broth, 334.
 oatmeal gruel, 330.
 peptonized milk, 332.
 raw beef sandwiches, 335.
 rules for diet, 327, 329.
 shirred eggs, 331.
 shredded-wheat gruel, 330.
 three kinds of diet, 327.
 wine jelly, 335.
- Silver, cleaning of, 43.
- Simmering, regulation of gas range burner, 16.
- Simmering-point of water, 26.
- Sink :
 care of, 37, 39.
 construction of, 37.
- Sink :
 fixtures, 37.
 porcelain, 37.
- Sirloin of beef, 155, 179, 187.
- Skim milk, use of, 96.
- Skirt steak, location, etc., 179, 189.
- Smelts, information about, 209.
- Smoke, product of combustion, 8.
- Soaps :
 chips, 362.
 composition of, 32.
 how it cleans, 32.
 scouring of, 33.
- Soapstone griddle, use of, 107.
- Soda :
 cleaning, care in using sal-soda, 33.
 hard water, softening, 24.
 in baking-powder, 108.
 in cream-of-vegetable soup, 257.
 in griddle cakes, 107, 109.
 study of, 107.
 test for, 108.
See also Baking-soda.
- Sodium, in the body, 142.
- Soft and hard coal, difference between, 17.
- Solids, explanation of, 27.
- Solubility of substances in water, experiments in, 22.
- Soot :
 preventing accumulation of soot in coal range, 10.
 product of combustion, 8.
- Sorting and soaking clothes, 361.
- Soup-making, 165-168, 253.
- Soup-stock :
 directions for making, 162.
 helpful hints about making and using, 166.
 materials for, 165.
 to clear, 167.
 use of vegetable cooking water, 253.
- Soups :
 bean purée, 258.
 cream-of-vegetable soups, 253, 255, 256.
 croûtons, preparing, 253.
 directions for making stock, 162.
 economical dish, 161.
 food value of, 168.
 green pea soup, 253.
 how to choose soup meat, 165.
 kettle for, 164.

Soups :

- materials for, 165.
- meat soup, 167.
- noodles, making, 168.
- soup-stock, 161.
- split-pea, 254.
- table of cream-of-vegetable, 254.
- tomato, 167, 256.

Sour milk :

- cause of, 96.
- neutralization of, by soda, 108, 109.

Spaghetti :

- manufacture of, 120.
- tomato sauce, 122.

Sparkling jelly, 170.

Spice :

- cake, 278.
- preservative, 296.

Spiced preserves, 303.

Spinach, information about, 251.

Split-pea soup (table), 254.

Spoiling of food, relation of bacteria to, 296.

Sponge :

- definition of, 127.
- for breads, 126.

Sponge cake :

- baking-powder, 279.
- definition of, 274.
- hints about making, 280.
- how to mix, 276.
- old-fashioned, 278.

Spores, 296.

Spring chicken, 194.

Spring wheat :

- composition of, 117.
- difference between spring and winter wheats, 81.

Sprouting of potato and composition of potato, relation between, 63.

Squashes :

- care of, 243.
- cooking, 244.
- information about, 251.
- selecting in market, 243.

Stains, fruit, removing, 364.

Stale bread, uses for, 134.

Standard cake, making, 51.

Starch :

- a carbohydrate, 72.
- action of saliva on, 70.

Starch :

- as food for body, 70.
- composition of, 70.
- digestion of, 70, 366, 368, 369.
- dry, 69.
- experiment in heating, 69.
- for laundry, 363.
- fuel for body, 70.
- in breakfast food, 75.
- other forms of, 69.
- sources of, experiments for, 67.
- starching, 363.
- study for, 68.
- test for, 61.
- use of, in cooking, 69.
- See also* Wheat, Flour, Potatoes, etc.

Steak :

- club, 178.
- Delmonico, 178.
- plank, 180, 189.
- Porterhouse, 178.
- round, 179.
- short, 178.
- sirloin, 179.
- skirt, 179, 189.

Steam :

- changing of water into, 26.
- definition of, 26.
- in cooking cereals, 74, 76.
- use of, for heating, 27.

Steaming :

- cereals, directions for, 76.
- definition of term, 49.
- double boilers, using, 74.
- moist and dry, 74.

Steel knives :

- cleaning, 34.
- removal of rust from, 42, 44.

Sterilization :

- definition of, 297.
- directions for sterilizing, 299.
- fruit, directions for, 299.
- milk, 321.
- sterilizing jars, 298.
- time required for, 300.
- to keep food, 297.

Stewing :

- chicken, 199.
- choosing meat for, 173.
- definition of term, 171.
- directions for stewing meat, 172.

Stewing :

- fruit, directions for, 236.
- helpful hints about, 174.

Stews :

- chicken for, 198.
- choosing meat for, 173.
- dumplings for, 172.
- lamb, 171.
- stock used instead of water, 167.
- to make, 172.
- what make, good, 172.

Stirring eggs, directions for, 90.

Stock-making, 162, 166.

Stomach, digestion of food, 369.

Stoves :

- broiling by gas or by coal, 156.
- cleaning and care of stoves, 45.
- construction and management of gas stoves, 13-15.
- ranges and stoves, distinction between, 9.

Strainer-cloths, washing, 44.

Strainers, wire, washing, 41.

Strawberries, canning, 302.

Strawberry ice-cream, making, 290.

String beans :

- composition of, 245.
- directions for canning, 302.
- information about, 249.
- preparing for salad, 259.

Striped bass, information about, 208.

Study of :

- apple, 227.
- bacteria, 294.
- baking-powder and soda, 107.
- bone, 163.
- coffee, 340.
- effect of heat on water, 25.
- growing vegetable, 240.
- milk, 93.
- starch, 68.
- structure of fish, 201.
- structure of oyster, 207.
- sugar, 265.
- tea, 337.
- wheat, 116.
- white potato, 60.
- yeast, 128.

Stuffed tomato salad, 260, 264.

Stuffing :

- for baked fish, 202.

Stuffing :

- recipe for, 197.

Suet, description of, 179.

Sugar :

- a carbohydrate, 265.
- as preservative, 296.
- boiling, 267.
- digestion of, 366.
- food value, 269.
- for modifying milk, 314.
- glucose in, 265, 266.
- growth of yeast hastened by, 129.
- kinds of, 266.
- made from starch, 268.
- maltose, formed in starch digestion, 70.
- manufacture of, 267.
- soluble in water, 22.
- study of, 265.
- See also* Candy making, Molasses, Honey, Syrup.

Sugaring fruits, 232.

Suggestions about :

- cooking and serving vegetables, 252.
- eating fruit, 230.
- order of work, 356.
- using fat in cooking, 225.

Sunlight :

- coal, sun as source of energy in, 17.
- natural cleanser, 30.

Swedish rolls, recipe for, 135.

Sweeping, 35.

Sweet breads, 183.

Sweet potatoes, cooking, 66.

- food value of, 66.

Sweets and sugar, 265.

Syrup, 268.

- See* Candy.

Table of information :

- beef, 186, 187, 188.
- cream-of-vegetable soup, 254.
- cuts of meat, 186, 187, 188, 189, 190, 191.
- fresh-water fish, 209.
- mutton and lamb, 191, 192.
- pork, 193.
- salt-water fish, 208.
- sugars, 270.
- vegetables, 248, 249, 250, 251.
- 100-calorie portions, 372.

- Tables, 49-50.
 clearing, 354.
 general rules for waiting on, 353.
 how to lay, 350, 353.
 laying, 350-353.
 linen decorations, 350.
 linen, special directions for laundering, 365.
 service, 348.
- Tallow, purified mutton fat, 181.
- Tannin :
 in coffee, 341.
 in tea, 338.
- Tapioca, apple, recipe for, 286.
- Tarnish, on metal :
 cause of, 34.
 explanation and removal of, 34.
 of silver, 43.
 removal of, 34.
- Tartar sauce, recipe for, 204.
- Tea :
 composition of, 338.
 directions for making, 338.
 effect of hot water on, 338.
 growth and preparation of, 339.
 how grown and made ready for market, 339.
 how to have good tea, 338.
 iced tea, 339.
 kinds and qualities of, 339.
 stimulating property of, 338.
 study of, 337.
- Tea-biscuit, recipe for, 105.
- Temperature of water, boiling and freezing points, etc., 26.
- Tenderloin, 158.
- Tender meat, cooking, 155.
- Tendon in meat, explanation of, 151.
- Theine, in tea and coffee, 338.
- Theobroma, the name given to cocoa, 343.
- Theory, definition of, 2.
- Thyme, 370.
- Tin, cleaning, 34.
- Tissue, definition of, 139.
- Tissues of the body renewed by food, 72.
- Toast :
 directions for making, 89.
 eggs dropped on, 90.
 mince meat on, 176.
- Toast :
 using gas range for toasting, 19.
 water, 89.
- Tomato :
 canning, directions for, 298.
 information about, 251.
 sauce, recipe for, 122.
 sauce, with chops, 157.
 serving, 247.
 soup, recipe for, 254.
 spaghetti, with sauce, 122.
 stuffed, salad, 263.
- Tough meat :
 explanation of, 155.
 stewing and braising, 171.
- Towels and cloths :
 care of, 44.
 special instructions for laundering, 365.
- Trade names of sugars, 266.
- Training for home making, importance of, 3.
- Tray for invalid, 336.
- Trypsin, 369.
- Turkeys, selection of, 194.
- Turnip, cream-of-turnip soup (table), 253.
- Typhoid fever, bacteria causing, 295.
- Utensils :
 care of, 311.
 washing of, 41.
- Vanilla ice-cream, making, 290.
- Vapor, definition of, 26.
- Veal :
 appearance of, 182.
 cuts of, 181, 190.
 how sold, 190.
 location of cuts of, 181.
 prepared for eating, 190.
- Vegetable foods, *see* Plant foods.
- Vegetables :
 canned, 244.
 care of, 243.
 composition of, 239-241.
 cooked, prepared for salad, 258.
 digestibility of, 242.
 dried, 244.
 food value, selection, etc., 240, 243.

- Vegetables :
- for salad, 258.
 - fresh, 243.
 - how to cook, 244.
 - preparation of fresh vegetables, 243.
 - protein in, 238.
 - purées, 253.
 - scalloped, 247.
 - seasoning, 246.
 - selecting for meal, 242.
 - selecting in market, 243.
 - served raw, 247.
 - soups, 255.
 - study of growing vegetables, 240.
 - suggestions about cooking and serving, 252.
 - table of information about, 248-251.
- Vermicelli, 120-122.
- manufacture, etc., 121.
 - soup, making and serving, 162.
- Villi, in intestines, 371.
- Vinegar, preservative, 296.
- Wafers, gluten, recipe for, 333.
- Waiting on table, 353.
- Warmed-over dishes :
- directions for, 175.
 - hash, 175.
 - meat pie, 177.
 - mince meat on toast, 176.
 - réchauffés, 175.
- Washing clothes, 361.
- Washing dishes :
- directions for, 41.
 - special instructions for, 365.
- Washing machine, 361.
- Washing soda, *see* Soda.
- Water :
- action of cold and hot water on meat, experiments, 154, 160.
 - as natural aid to cleanliness, 30.
 - as product of combustion, 8.
 - boiling point of, 25.
 - characteristics of good drinking water, 23.
 - composition of, 27.
 - directions in freezing, 289.
 - drinking, 24.
 - effect of cold on, 27.
 - effect of, on tea, 338.
 - facts about, 27 n.
- Water :
- filtering, 24.
 - formation of ice, 28.
 - function in the body, 140.
 - hard, 24.
 - impurities in, 23.
 - in nature, 22.
 - in relation to health, 28.
 - lemon ice, 291.
 - natural cleanser, 30.
 - potatoes, percentage of water in, 62.
 - pure, 23.
 - soft, best for cleaning and cooking, 24.
 - solvent, water as, 22.
 - uses, composition, etc., 28.
- Water-bugs in kitchen, exterminating, 46.
- Water-ices :
- directions for making, 289.
 - recipe for lemon ice, 291.
- Water toast, making, 89.
- Weakfish, information about, 209.
- Weights and measures :
- directions and tables, 53.
 - honest, 53.
- Welfare :
- family, 1.
 - national, 1, 2.
- Wells, pollution of, by sewage, 24.
- Wheat :
- analysis of wheat flour, 116.
 - composition of, and structure, 117.
 - direction for cooking, 79.
 - examination of wheat grain, 117.
 - food value, 120.
 - ginger snaps, 279.
 - gluten, 116.
 - harvesting, 81.
 - how seedling is fed, 81.
 - kinds of, 81.
 - king of cereals, 80.
 - meal, bolted and unbolted, 119, 120.
 - shredded-wheat gruel, recipe for, 330.
 - spring and winter wheat, 81.
 - study of, 116.
- Whey, 93.
- Whipped cream, recipe for, 101.
- White bread :
- comparison with other foods, 136.
 - making, 127.
- Whitefish, information about, 209.

- White fricassee of dishes of chicken, preparing, 194, 195.
- White of egg :
composition of, 85.
separating from yolk, 90.
- White potato, study of, 60.
- White sauce, recipe for, 247.
- Whole-wheat :
bread, making, 124.
flour, production of, 120.
ginger snaps, making (table), 279.
muffins, recipe for, 113.
- Wine jelly :
recipe for, 335.
- Winter and spring wheats, difference between, 81.
- Women, the home makers, 1.
- Wood, cleaning, 35, 36.
- Woodwork, care of, 35.
- Working-men, diet of, 147.
- Work of the body, 71.
- Wringing, 362.
- Yeast :
action in bread raising, 132.
action of, on sugar, 130.
alcohol in, 131.
bacteria compared with, 295.
causing fermentation, 294.
composition of, 128.
cultivated yeasts, 131.
dried, 131.
growth of, 129, 130
home-made, 130.
oxygen obtained by, 130.
story of, 129.
study of, 128.
to make, 123.
yeast garden, 132.
- Yolk of eggs :
composition of, 85.
separating from white, 90.
- Zein, 141.
- Zinc, cleaning, 45.



THE following pages contain advertisements of a
few of the Macmillan books on kindred subjects



THE HEALTH SERIES OF PHYSIOLOGY AND HYGIENE

By M. V. O'SHEA

Professor of Education, University of Wisconsin, Author of
"Dynamic Factors in Education," etc., and

J. H. KELLOGG

Superintendent of The Battle Creek Sanitarium, Author of
"Man, The Masterpiece," etc.

Health Habits	\$.45	The Body in Health	\$.65
Health and Cleanliness55	Making the Most of Life65

The O'Shea and Kellogg Health Series of Physiology and Hygiene is devoted to the education of children for health. It presents a complete course of instruction, covering every phase of the child's physical health and welfare. These books and the lessons in each book have been written in the fullness of knowledge of the subject and with a deep and sympathetic understanding of the nature and the needs of children.

The characteristic features are :

1. The lessons encourage children to form health habits. They supplement the instruction given in physical training, play, and exercise toward the formation of habits of posture; and they establish the child in the right habits of bodily maintenance, rest, recreation, and personal hygiene.
2. The lessons harmonize the health work of the school, the home, and the community. They teach children also how to be of service to themselves and others in emergencies.
3. In these lessons children are taught the elementary facts and principles of physiology and hygiene. They are taught to understand with sympathy the machinery of the human body, its needs and processes, its purposes and functions; and they are taught to build up the fortifications and defences of the body against disease.

The Health Series of Physiology and Hygiene is adapted in every feature for use in elementary schools. The four books make a complete and noteworthy course of instruction. Each book is, however, complete in itself and can be used independently.

THE MACMILLAN COMPANY

BOSTON
CHICAGO

NEW YORK
SAN FRANCISCO

DALLAS
ATLANTA

THE NEW GEOGRAPHIES

BY THE LATE RALPH S. TARR AND FRANK McMURRY

First Book \$.65 Second Book \$1.10

The Tarr and McMurry New Geographies represent ideas that make the teaching of geography produce results. Distinctive features are :

1. The emphasis of humanized geography. The physiographic and geological studies in geography are made subordinate to the industrial activities, the history, the education, and the development of the people.
2. The basis in home geography. In the beginning of the course and throughout the course, the study of geography is constantly related to the pupils' own experiences.
3. The stimulus to self-activity. Pupils are taught how to study, led to think about human problems, and encouraged to use thought rather than memory in their study.
4. The organization of material. The material of instruction is grouped under topics; topics are grouped under main topics. The individuality of each topic is recognized. There are frequent comparisons with the United States as a basis, and reviews.
5. The use of the type method. Wherever it can be used to advantage in presenting geographical concepts, in developing the ideas of institutions, regions, or industries, the type method is used.
6. The appeal to the interest of children. Interest is gained and held by an adequate treatment of topics worked out in sufficient detail to make the meaning clear.

In every feature **The Tarr and McMurry New Geographies** are in harmony with the principles of modern pedagogy. They challenge comparison.

THE MACMILLAN COMPANY

BOSTON
CHICAGO

NEW YORK
SAN FRANCISCO

DALLAS
ATLANTA

ENGLISH SPOKEN AND WRITTEN

By HENRY P. EMERSON

Superintendent of Education, Buffalo, New York, and

IDA C. BENDER

Supervisor of Primary Grades, Buffalo, New York

Book One, Lessons in Language for Primary Grades	\$.35
Book Two, Lessons in Language, Literature and Composition50
Book Three, Practical Lessons in English Grammar and Com- position60

The **English Spoken and Written Series** of textbooks in language has gained recognition for merit in teaching elementary English effectively. The characteristic features of the series are :

1. Definiteness and preciseness of aim. The chief aims of the English course — the mastery of oral and written expression and the development of the power of language appreciation — are kept constantly before the teacher and pupil.
2. Constructive language work. Interesting, progressive, and constructive language lessons are organized into a complete, definite, and effective course of instruction. In this course, oral English plays an important part. It is the basis of instruction and an important factor in the development of every topic.
3. Effective correlation. The language work is correlated with the other subjects of elementary instruction and with the material of instruction that is to be gathered by the pupils out of school life. The reading done in school and at home is, likewise, made the basis of particular individual language lessons.
4. Well planned treatment of language and grammar. Language training is the main purpose of the series. Training in English grammar is given its proper place in the course. It is introduced and emphasized at the right time.
5. Reviews. There is ample provision for review work. Every new principle is developed with a sufficient number of exercises for practice and review. Cumulative reviews are also provided.

The success with which **English Spoken and Written** has been used indicates that it endures well the test of use.

THE MACMILLAN COMPANY

BOSTON
CHICAGO

NEW YORK
SAN FRANCISCO

DALLAS
ATLANTA

THE NEW SLOAN READERS

By KATHERINE E. SLOAN

Author of "Primary Reading"

The Primer . . .	\$.30	The Second Reader	\$.35
The First Reader . .	.30	The Manual for Teachers25

The New Sloan Readers is a new series of method readers, designed to develop in the shortest possible time by the simplest and most direct methods the independent power to read.

The Primer. In *The Primer* the child proceeds from the story to the sentence and learns to recognize quickly and to read naturally the first simple lessons, sentences, and sight words. From these lessons he passes naturally to the first lessons on phonetic elements. Reading lessons, phonetic drill lessons, and word-building lessons succeed each other in pleasing variety throughout the book.

The Primer is designed for the first half year of school work. It teaches the child as a memory requirement to recognize seventy-two sight words; to give correctly the sound of the first twenty-seven simple phonetic elements; to repeat from memory a select list of simple rhymes and poems; and to read a goodly number of complete stories.

The First Reader. *The First Reader* gives special emphasis to the development of the power to read simple phonetics. These phonetic lessons are taught in connection with lessons on splendid stories and poems for continued reading and drill.

The Second Reader. *The Second Reader* aims to establish the child in the independent power to read. Charming lessons in story and poetry make up the reading content of the book. These offer the opportunity for drill in appreciative and expressive reading.

The Manual. *The Manual* for teachers is an aid to effective teaching. It explains the plan and discusses in detail the methods that are used in systematizing the work and in teaching the daily lessons.

THE MACMILLAN COMPANY

BOSTON
CHICAGO

NEW YORK
SAN FRANCISCO

DALLAS
ATLANTA

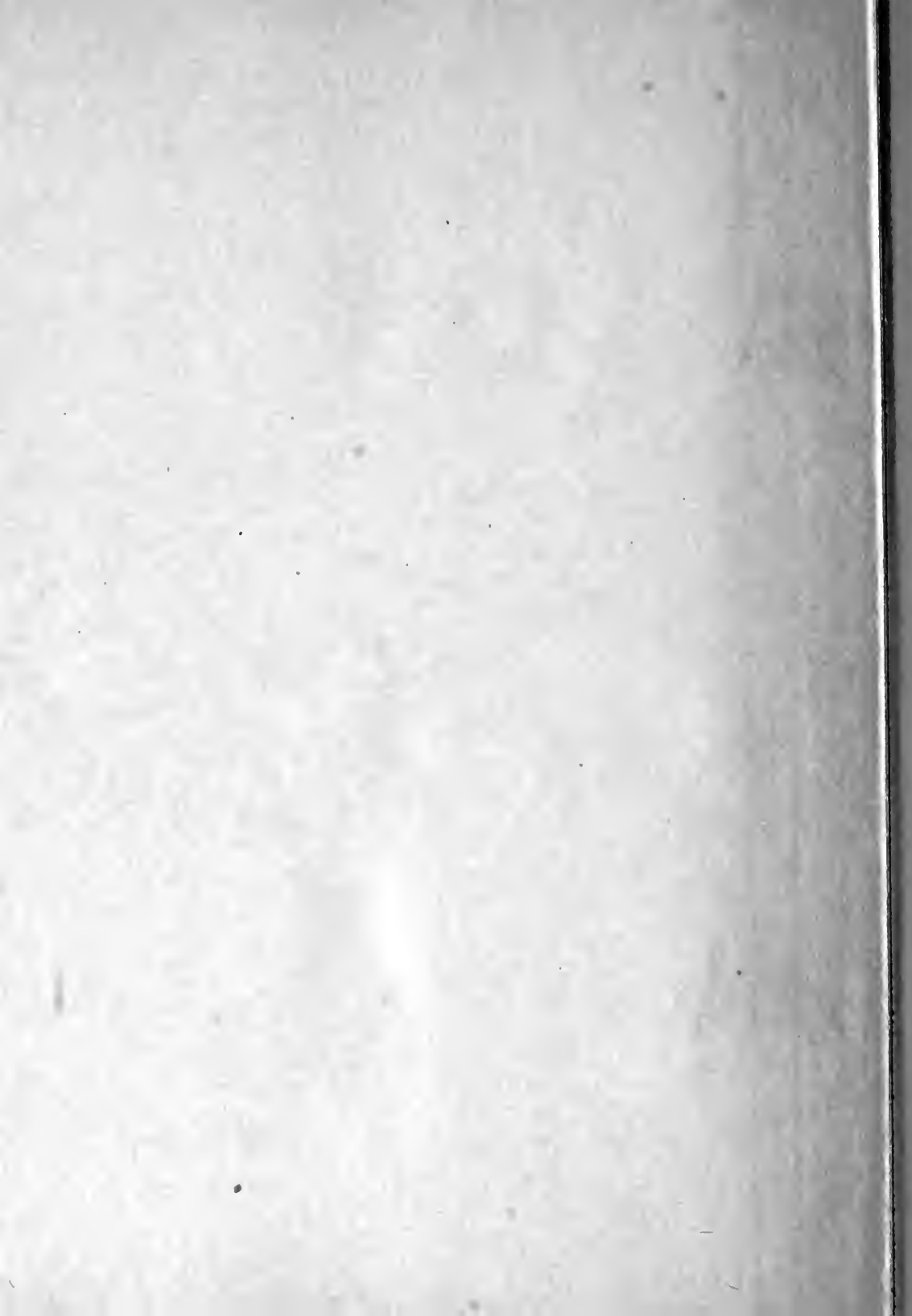



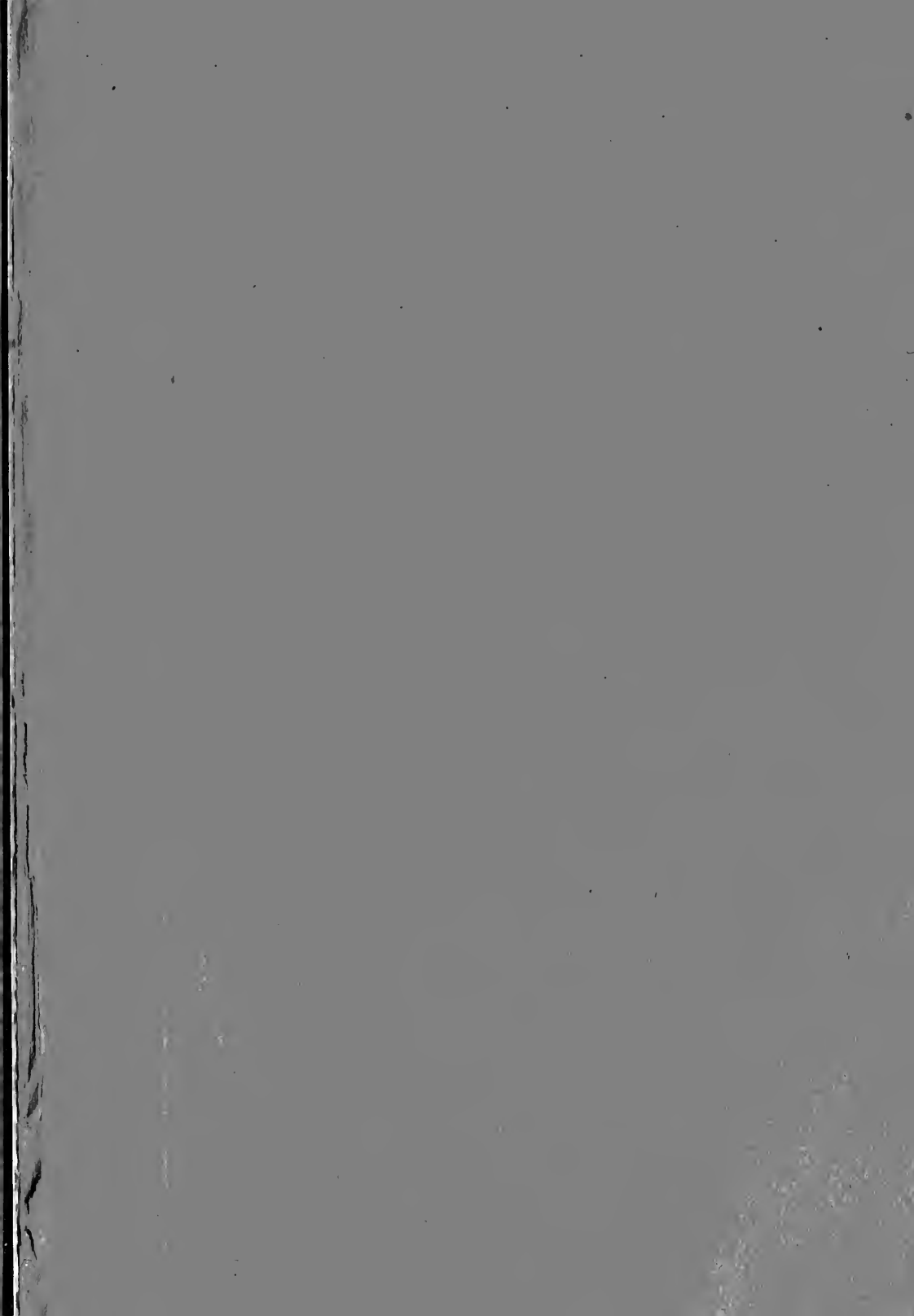

LIBRARY OF CONGRESS



0 014 485 839 6

